

Volume XV.

No. 1.

FEBRUARY, 1884.



Entered at the Post Office in New York as Second-Class Matter.

42 NASSAU STREET, NEW YORK.

410 St. Michael St. (Sub. No. 1, 407)

11 1026



Digitized by the Internet Archive  
in 2016

[https://archive.org/details/jewelerscircular00unse\\_2](https://archive.org/details/jewelerscircular00unse_2)



# THE AMERICAN LEVER CUFF AND COLLAR BUTTON





Hutchison & Huestis,  
Makers of \* Solid Gold  
STONE RINGS,  
185 EDDY ST. \*  
PROVIDENCE, R. I.  
New York Office, \* 196 Broadway

\* FOR JOBBING TRADE ONLY. \*







VOLUME XV.

NEW YORK, FEBRUARY, 1884.

No. 1.

## THE JEWELERS' CIRCULAR AND HOROLOGICAL REVIEW

*The recognized organ of the Trade, and the official representative of the  
Jewelers' League.*

A Monthly Journal devoted to the interests of Watchmakers, Jewelers, Silver-  
smiths, Electro-plate Manufacturers, and those engaged in the  
kindred branches of art industry.

### SUBSCRIPTION:

To All Parts of the United States and Canada,  
**\$2.00 Per Annum; Postage paid.**

To Great Britain, France, Switzerland, Germany, the West Indies, Mexico, the  
Republics of South America, and Australia, \$3.00 per annum. Postage paid.

*All communications should be addressed to D. H. HOPKINSON, 42 Nassau  
Street, New York. Advertising rates made known on application.*

THE JEWELERS' CIRCULAR AND HOROLOGICAL REVIEW enters upon  
the Fifteenth year of its publication with the issue of this number.  
In accordance with an established custom, all Subscriptions termi-  
nating with the January issue will be discontinued if not renewed.  
We hope to have all our old friends continue with us, and to add  
many new names to our list of Subscribers. We hope that our  
friends will notify us at once if THE CIRCULAR fails to reach  
them on its monthly mission; on so doing we will forward the  
missing copies.

### The Abomination of Preferred Creditors.

THE JEWELRY trade is of all others the greatest sufferer from  
the innumerable abuses of the credit system. Every trick and  
device ever devised by slippery debtors for defrauding their credi-  
tors has been practiced with great success and frequent repetitions  
upon the complacent and confiding jewelers. But of all the slip-  
pery abuses inherent in the credit system, there is none that can  
compare for "pure cussedness" with this preferred creditor business.  
There are instances where, in the case of the failure of a dealer,  
certain creditors are very properly given the preference; but to  
every one such case there are a dozen where giving preference to  
creditors is little better than highway robbery. We have frequently  
commented upon the careless manner in which credit is given in the  
jewelry trade. Any person who will cause his name to be printed  
upon a business card announcing that he is a retail jeweler can get  
almost unlimited credit. Let him put up for a few days at the Astor  
House, and he will find himself besieged with drummers anxious to  
secure his orders; when one sells him others follow suit, for they  
are so fearful that some competitor will get an advantage over them  
that they are willing to "take their chances" with a stranger, and  
trust him with hundreds of dollars worth of goods, when they would

not lend him fifty cents in cash. They seem to forget that goods  
represent a cash outlay on their part, but argue that this man may  
possibly pay his bills for a year or so, and then if he does go up they  
will not be heavy losers. And so these manufacturers and jobbers  
go on year after year giving credit promiscuously and uninquiringly,  
and by so doing virtually holding out a premium to unscrupulous  
men to step in and victimize them—an invitation that has, unfor-  
tunately, been accepted in too many instances.

This giving of credit would not be so bad provided creditors could  
recover their goods in the event of the debtor being unable to sell  
them legitimately. In many other lines of trade manufacturers fre-  
quently establish retail dealers in business by fitting them out  
entirely with stock of goods, but in such cases the manufacturer is  
careful to retain a hold upon the goods so that he can reclaim them  
in an emergency. But the jewelers are content to "take their  
chances" in this respect, and when a dealer has once obtained pos-  
session of their goods he is at liberty to do what he pleases with  
them. He may devote two or three years to working up his credit  
in the trade, till finally he has a valuable stock in hand and the time  
is ripe for him to fail. He announces the fact of his suspension to  
his creditors, and they take steps to secure themselves—on the prin-  
ciple of locking the stable door after the horse is stolen. Investiga-  
tion soon reveals the fact that the debtor has got the best of them  
by having named several persons as preferred creditors. These are  
usually relatives, wife, brother, brother-in-law, sisters, cousins, aunts,  
kin by blood or by marriage, who swoop down upon the stock and  
secure whatever is left. There have been instances where over fifty  
persons have been named as preferred creditors, all of whom were to  
be satisfied before the general creditors stood any chance whatever of  
securing their rights. Great abuses and cleverly concocted frauds have  
been perpetrated upon the trade by means of this preferred creditor  
dodge, some of them so transparent that the debtor himself scarcely  
attempted to disguise the fact. Instances are known where these  
preferred creditors have come forward after a settlement, and recon-  
veyed the property they had secured to the debtor who had failed,  
and he has resumed business with the identical goods his legitimate  
creditors had been swindled out of. But what is worse, under the  
lax credit system in the jewelry trade, the debtor's credit was  
scarcely impaired, and the very houses he had victimized were ready  
to sell him more goods.

While the trade is much in fault in maintaining such laxity in the  
giving of credits, the law is at fault that permits designing men to  
perpetrate such frauds upon their creditors as we have alluded to.  
What is needed is a new national bankruptcy law so framed that  
while it will afford all the protection necessary to honest debtors,  
will also protect the creditor class from the numerous tricks and  
devices invented by designing men to defraud them. Congress will  
be asked this winter to pass such a law, and it is to be hoped that  
something will be agreed upon that will give greater security to  
creditors. In a new country like ours, so vast in extent and so rapid  
in its development, business must naturally be conducted largely upon

credit. Commerce between the several states has grown to such proportions that it cannot be regulated by state laws especially when the laws of the different states relating to the subject are as wide apart as it is possible to make them. The credit system which is the foundation upon which commerce rests should be as much the subject of national legislation as the subjects of navigation and transportation. A debtor in Illinois or Dakota should have no greater facilities for escaping his obligations than he would if he lived in Maine or New York; his creditors should have the same hold upon him in one state as in another. It is pretty hard that New York merchants, selling their goods in accordance with the laws of this state and paying for the privilege of doing so, should be defrauded of the value of their goods through the loopholes provided for the escape of debtors by the laws of another state. The remedy for all existing incongruities in state laws relating to the creditor and debtor classes lies in a national bankruptcy law.

Copies of a national bankruptcy law, prepared by Judge Lowell, of Massachusetts, has been widely circulated, and has received the approval of numerous boards of trade and other commercial bodies. It is more than probable that it will be adopted by Congress. If any one in the jewelry trade has any suggestions to make regarding such a law, now is the time to do it. If, however, the bill as printed and circulated is satisfactory, the trade should take measures to give it their endorsement and to urge its passage. An industry so deeply given over to the credit system and that is so extensively victimized by unscrupulous debtors, should not stand silently by when measures intended for their protection are under discussion. A national bankruptcy law will do away with the preferred creditor abuse as well as many others that now exist, and at the same time give creditors a more secure hold upon their debtors.

---

### Decadence of the Apprentice System.

WE DO not remember when there has been so great a demand for competent workmen in the jewelry trade as during the past year, nor a time when such demand was so hard to fill. We are in constant receipt of applications from jewelers and watchmakers in all sections of the country for workmen who are able to do the general run of work that comes to dealers located in small places, from repairing a fine watch to soldering a pin on a broken breastpin. While we have sent a number of workmen in response to these applications, in many instances we have been unable to comply with them, while at the same time there were several names of workmen on our books desirous of situations. The trouble was that they were not *competent* workmen—they have a little smattering of the business, but never having served an apprenticeship were wholly incompetent to attempt the general work that ordinarily flows into the shop of a retail dealer; a complicated watch would be to them as great a mystery as the Sphinx, and even some of the tools of their trade would be puzzles to them. The fact is, the boys of the present day are too ambitious to become "mere mechanics;" they aim to achieve fortunes speedily, and would sooner commence their business life as an office boy for some stock broker or gambling speculator than to attempt the irksome apprenticeship necessary to make them competent workmen in some honorable branch of industry. Indeed, there are no apprentices nowadays; occasionally a lad can be found who is willing to work in a shop till he can "find something better to do," but the idea of "learning a trade" is repugnant to them. These few shop boys go on for a time, picking up a little information now and then, catching up a few technical phrases, watching the workmen and "doing the chores," but at the end of a few months they feel they have learned all there is to know, and so set themselves up as journeymen. If they are fortunate to find employment as such, their first week's experience only serves to prove how little they know, to disgust their employer, and to secure for themselves

"the grand bounce." They are now started on their careers as tramping journeymen, too ignorant of their trade to hold a situation, and too proud or too indolent to commence at the bottom again and learn their trade thoroughly. There are hundreds of workmen who have had just such a start as this. They never intended to make themselves competent workmen, but made a convenience of the trade till something better should offer itself. Like Micawber, they are "waiting for something to turn up" that will enable them by a lucky chance to accumulate a fortune and cut the shop. The decadence of the apprenticeship system has been fatal to the development of accomplished American workmen. The introduction of machinery into so many branches of the trade has also had a tendency to prevent boys from acquiring a thorough knowledge of the trade. As boys they enter a factory, and, after serving a time as errand boys, they are placed in charge of a machine that does one certain thing; they learn to run this machine, to do it well, and to become experts in the production of this one thing; beyond that they learn little. They are more valuable to the employer when doing well the one thing they know how to do than they would be learning the trade thoroughly, so they go on year after year tending the same old machine; probably after a time they get paid by the piece for what they produce, then their ambition is to earn as much as possible, and they have no ambition to learn anything further. Of course, these never become competent workmen. Trades unions, too, are largely responsible for the fact that there are so few good workmen. When labor was in the ascendancy and held capital by the throat, and was able to dictate its own terms, the trades unions limited the number of boys that might be employed in each shop, and, consequently, the opportunities for boys to learn trades were greatly reduced. As a consequence, good workmen, who would have been glad to have apprenticed their boys, have been forced to see them grow up in idleness, become street loafers, possibly criminals, because the privilege of earning a living honestly was denied them by trades unions.

From a variety of causes, a few of which we have alluded to, good American workmen are hard to find, and there are comparatively few being trained for future demands. The result of this is that foreign workmen are filling the places that our own native born citizens might have if they would consent to become mechanics instead of builders of castles in Spain, wasting their time scheming how to become suddenly rich. Of course, there are many expert American workmen, but not enough to supply the demand. When an American does take the trouble to learn a trade thoroughly, he generally makes the very best kind of a workman, for, in addition to his acquired skill, he brings general intelligence, native ingenuity, quick wit, and a degree of perseverance that will never acknowledge itself conquered. It is a great pity that more of our boys will not consent to learn trades, for with a good trade at his fingers' end, a man may defy poverty and misfortune for he always has a living at his command. It gives him a feeling of independence and more courage to enter into the battle of life. It is to the general decay of the apprenticeship system that we have to attribute much that is dangerous and extravagant in social tendencies and trade management. American boys too seldom choose to take up a respectable trade in the thorough manner that makes both the occupation and themselves honorable. They propose without any consideration of their ability to enter the professions or to become immediately rich men—to be, in short, "as good as anybody." They pass through the public schools and are apt to emerge half-taught, shallow and inefficient, with no preparation for the practical work of life. If they were taught good trades and made to feel the dignity of labor, and to appreciate the responsibilities incident to manhood, we should have fewer tramps wandering about the country and fewer convicts in our States prisons. Employers might contribute much towards securing a reform in this matter by emancipating themselves from the control of trades unions, and taking more pains in the education of the young men in their employ.

### The Catalogue Nuisance.

THE ISSUING of expensive catalogues by jobbers has grown to be a most objectionable feature in the jewelry trade, and was never carried to greater excess than during the year just past. Some certain jobbers have displayed an amount of ingenuity and smart business tact in getting out voluminous catalogues to serve as advertisements for themselves, without incurring any expense that would do them credit if employed in some more legitimate enterprise. Having in stock goods purchased from a multitude of manufacturers they notify each one that they propose to issue a catalogue, and to include therein illustrations of the goods manufactured by him; he is asked to forward the cuts for the illustrations, or if he has no cuts the jobber offers to have them made. As manufacturers seldom do have cuts on hand, the jobber goes ahead and has them made and charges them up to the manufacturer. Frequently the manufacturers are asked to make direct contributions to defray the expense of publishing these catalogues, and are expected to respond in sums varying from \$20 to \$200. In some instances the manufacturer is left no option in the matter; the jobber goes ahead and gets out a catalogue to suit himself and then assesses each manufacturer a proportion of the expense, and without so much as asking permission charges the amount up on his books. This practice has grown into a gross abuse; it is little better than levying blackmail upon the manufacturers, for if they refuse to allow the charges thus made against them the jobber withdraws his patronage. When half a dozen or more jobbers attack a manufacturer in one season the tax becomes considerable of a burden, while the catalogues thus issued are for the sole glory and profit of the party issuing them. They do not bring a dollar's worth of custom to the manufacturers who have to foot the bills, for they are not circulated among the jobbers who are their patrons, but among retail dealers and outsiders who buy from the jobbers. Instances are named where the persons getting up catalogues in this way have derived a handsome surplus over and above the cost of printing from the assessments levied on the manufacturers.

In addition to this practice being an imposition upon the manufacturers, its effect is to make a discrimination against those jobbers who do not get out catalogues, but advertise in some other way and pay their own bills. The catalogue publisher who is sharp enough to make the manufacturers pay for their advertising have just so much the advantage of their competitors, and the latter would be justified in demanding from the manufacturers an additional discount sufficient to even up the account. This little game has been successfully played for a number of years, but manufacturers are beginning to see the injustice of it and are not likely to encourage it to any great extent in future.

Jobbers' catalogues are supposed to be issued for the information and benefit of the retail dealers, who are supposed to glean from their illustrated pages much valuable information regarding styles and designs in jewelry. As a matter of fact they are misleading and deceptive, and the retail dealer who accepts them as his guide will find himself far behind the times. It is impossible for a jobber to issue a catalogue that will give any idea of the latest novelties introduced. Styles are constantly changing, and by the time the jobber has received new goods, had cuts made, arranged his catalogue and had it printed, months have elapsed since the goods were new and fresh, and by the time the retail dealer reads about them in a catalogue they have gone out of date. This phase of the business was especially commented on during the past season by many distant dealers who visited New York for the first time. They found the variety and styles of goods then popular very different from what were represented in the jobbers' catalogues they had received. The impossibility of representing fresh novelties in catalogues issued once or twice a year will be apparent to anyone who stops a moment to think how much work and time must be expended in the preparation and printing of such volumes. We have received numerous protests from retail dealers against jobbers' catalogues; they com-

plain that they are not only misleading to them, but when sent out broadcast they encourage the outside trade to ignore the retail dealers and send orders direct to the jobbers. It is bad enough when the catalogues are confined to retail dealers, but when the jobbers send them out to every address they can find the evil is greatly magnified.

In what we have said here about catalogues we do not refer, of course, to such as are issued by manufacturers of materials, tools, etc.; it is essential to the trade that such catalogues should be issued; but we refer exclusively to the hodge-podge catalogues got out by jobbers, representing goods made by various manufacturers, which goods are neither new nor fresh when the catalogue is distributed. Many a dealer has been loaded down with old styles of goods that were unsalable in consequence of having made up his orders from catalogues. They may sometimes help a jobber to work off his shop-worn stock, but they are not to be trusted as guides for buyers. If the manufacturers who have been victimized by this catalogue nuisance, and the retail dealers who have been misled by it, will persistently discourage the catalogue makers in the future, this abuse will be speedily consigned to oblivion. There are other and better ways of advertising, and more direct and legitimate methods of reaching the retail trade.

---

### Cause and Effect.

THE YEAR 1883 was remarkable chiefly as witnessing in the business world an unremittent continuation of the reaction from a period of exceptional prosperity, commencing with the resumption of specie payments in 1878, and culminating say in the earlier months of 1881. It has been a reaction attended by some characteristics without precedent; but, happily, characteristics which fairly justify the hope that the depression, if not already spent, is at least approaching a point now which will mark the turn of the tide.

Prominent among these characteristics has been the total absence of the panic feeling, in the face of a severe and progressive contraction of market values, not only in every class of securities dealt in at the Stock Exchange, but also in manufacturing products and the leading staple commodities. The readjustment or liquidation has been accomplished, or is now undergoing accomplishment, by easy and natural stages, and with infinitely less disturbance of the equilibrium of things than in former years would attend the collapse of some prominent commercial firm, the bankruptcy of a railway corporation or the stoppage of a bank. This is a suggestive and highly gratifying circumstance; and the philosophy of it is, that the trying experiences of the past quarter of a century, largely consequent upon a four year's civil war which subjected the moral and material fiber of the country to its utmost tension, have endowed our people with the valuable quality of self-poise or self possession, which enables them to bear up under adverse circumstances with a patient philosophy and a spirit of hopefulness which, even when clouds are thickest and darkest, never loses sight of the silver lining. A people with these qualities may have their periodical repulses and their periods of interrupted prosperity, but, with reserve powers of recuperation so pronounced, their onward progress can never be permanently arrested.

We have spoken of the commercial reaction which distinguishes the closing year as but a continuation of, or an appendix to, events that were in progress throughout the preceding eighteen months. The recovery from the sweeping financial revulsion of 1873, which was participated by all classes of business interests, may be said to have been progressive from 1877 to 1881, and to have about reached its climax with the assassination of President Garfield. The antecedent economic conditions of excessive speculation, and overstimulated industries restricted to home markets, were such as to impart to that event an influence upon the public mind which prob-

ably would not have been felt under other circumstances. The credit system had been imprudently, not to say recklessly expanded, and numerous undertakings of one kind and another were launched on borrowed capital, only to be cast away on the shoals of bankruptcy a few months further on. About the same time unhealthy symptoms were developed in our foreign trade. Excessive importations were productive of financial embarrassments, particularly in the coffee trade; and superadded to these premonitions of impending trouble was an abnormal activity in a great variety of unproductive railroad projects which could promise returns upon fixed capital only in the remote future. These and similar events were aggravated by the feverish condition of the public mind, consequent upon political contention, in and out of Congress, as the result of a new administration. But though the country had now passed the top wave of three years' almost unprecedented material prosperity, the ebb of the tide, if not absolutely arrested by abundant crops and a profitable export trade, was so gradual as to be productive of nothing of that feeling of alarm and the universal impairment of confidence which followed the financial cataclysm of 1873.

This, in brief, was the situation and the prospect at the commencement of 1883, and the whole course of events since that time has been wholly in harmony with it. Liquidation and contraction have been the order of the day, accelerated undoubtedly by the unsatisfactory results of the cereal harvests, the abundance of which the previous season, as we have said, tended to arrest and otherwise modify the unsatisfactory aspects of the situation during the later months of 1882. It is aside from our present purpose to follow in detail the various incidents which have marked this liquidation and contraction from stage to stage; but we may reiterate the gratifying reflection that, as it has been accepted by the country as the natural, if not always foreseen, consequences of well understood causes, the year under review has been absolutely free from panic, as that phase is usually understood, as if under a conviction in the public mind that just as soon as these causes cease to operate the commercial and business world will regain its former elasticity. These causes have been many, and while not a few of them are no longer felt as obstructive influences to business recuperation, it would simply be deceiving ourselves to refuse to recognize those that have still to run their course and work out their consequences.

With regard to railway construction, it must be borne in mind that the final stoppage of all that class of enterprises has not yet been reached. Contracts for new roads are no longer entered into, but a great deal of actual work is still going forward in the way of completing lines which had their inception in the era of prosperity; while at the same time the Stock Exchange has been flooded with a good many millions of obligations upon which the credit of these roads, and their consequent ability to sustain themselves in the future largely depend. The iron and steel trades have doubtless experienced the full effects of this suspension of railway construction, but the labor market has yet to be brought within its influence; at a time, too, when with a curtailment of manufacturing industries the surplus of unemployed industry must be largely increased. The wages question, under these circumstances, will have to be met before the conditions of recuperation are on a solid basis. For that matter, it is already being forced to a practical issue by the numerous strikes against reduction in various parts of the country, and the result must be in the natural order of things, the acceptance of the inevitable. We likewise look for lower rents, and some abatement of colossal city real estate undertakings which have been so conspicuous a feature of the times, not only in the commercial cities on the seaboard, but throughout the interior, and it will be fortunate if the abatement is accomplished without financial inconvenience for individuals and corporations that have large amounts of capital locked up in them. Aside from these, we have a noticeable cessation of various other business enterprises requiring large amounts of capital, of which we have convincing proof in the existing abundance of money, with little demand for it, at abnormally low rates.

Nor can the fact be overlooked that the beginning of the year finds merchants and manufacturers with large stocks of staple and manufactured merchandise, and at market prices which in many cases contrast strikingly with those of previous years. We might cite current prices of numerous articles of necessity as showing that the cost of many prime commodities is down to a figure which might reasonably suggest a fair basis for hard-pan, if not an upward reaction, as soon as other conditions have passed the final stage of readjustment. Among these other conditions we include the uncertainty in regard to the impending revision of the tariff, the re-opening of discussion of the finances and the more or less disturbing influences of an approaching presidential election. But, in any event, balancing one thing with another, the outlook for the new year, if not warranting over-sanguine anticipations, is certainly not such as to justify discouragement or despondency. The country was never more affluent than it is at this moment in all the solid elements of prosperity, and it but requires a continuance of the same patience and the same courageous spirit which have characterized our people during the two trying years of liquidation through which they have been passing—supplemented by wise legislation on the part of the National Legislature—to bring commerce, trade and industry up to the high plane of prosperity from which, under the force of circumstances, they have but temporarily descended.

---

A JEWELER IN conversation with a reporter of the daily press made the very true observation that "imitation kills fashion." "I have been forcibly struck," says Brunswick, in the *Boston Gazette*, "with this during the last few years. I defy the best maker of fine jewelry to get up a design that the plated men won't attempt to copy. Look through the cases of the leading retailers in town and you will see fine specimens of Egyptian bangles in silver and gold that cost from \$10 to \$50 respectively, and you go to Daniel's, Macy's or Stern's, and you find the same display in washed silver or alleged rolled plate for \$1 and \$2. These goods are made to catch the eye and the dollar of that class of women who are constantly trying to ape their betters. If she can't get the exact materials of her neighbor's dress, she will have something so near it that the neighbor would stand aghast when she meets her. I have seen girls coming out of tenement houses dressed to all appearances as girls who come out of Fifth avenue houses. At a casual glance you can hardly tell the difference. In the winter I used to be continually startled by meeting what appeared to be young ladies of fashion in the unfashionable neighborhood of the lettered avenues. The tight-fitting jackets, coachman's capes, large hats and long gloves gave them at a distance a most picturesque and fashionable appearance. Closer inspection showed the fur cape to be imitation, and the other materials of the cheapest sort. But the wearer was quick of eye and nimble of finger, and made herself look fashionable at least."

The gypsy rings, those with the stones set flush with the gold, were until lately only made by first-class jewelers; now they are imitated by the cheap Johns, with rings that look as though they might have been heirlooms in some fine family, but which upon examination prove to be imitation stones set in alleged rolled gold. The dog collar, once so popular as a neck ornament, went entirely out of fashion owing to imitation. I see, however, that they have come up again, and some very unique and costly designs are now offered. The imitators are not baffled by antiques. For a time scarf pins were fashionable and quite expensive. The coins were genuine and the setting of gold. You can buy them to-day for 20 cents, the coins looking just as ancient and the brass of which they are made will for a while shine like pure gold.

---

AN EXAMINATION in detail of the business troubles of the year confirms the general impression that 1883 was an unfortunate twelve month. It is estimated by the different commercial

agencies that the failures for 1883 numbered 9,184, which is about 1,000 less than other estimates have made it. Most of the losses were small ones; but the total liabilities were swollen by the ruin of a number of larger speculating firms. A satisfactory offset to these disheartening statistics is found in the general condition of the country, which so far from being exhausted contains every promise of unequaled prosperity for the new year. While the jewelry trade had its fair proportion of insignificant failures it was not afflicted with any one that entailed severe losses. Those of any respectable dimensions that occurred were due to legitimate causes, and were not characterized by chicanery of any kind, which cannot be said of some of the smaller ones. There is nothing in the outlook to cause despondency in the trade or distrust of the future.

THE ANNUAL proclamation of the Secretary of the Treasury, of the values of foreign coins expressed in the money of the United States, to be taken in estimating the values of all foreign merchandise made out in said currencies, imported on or after January 1, 1884, makes the following changes from the proclamation of January 1, 1883: Austria, florin, from 40.1 to 39.8 c.; Bolivia, boliviano, from 81.2 c. to 80.6 c.; Ecuador, peso, from 81.2 c. to 80.6 c.; India, rupee, from 38.6 c. to 38.3 c.; Japan, yen, from 87.6 c. to 86.9 c.; Mexico, dollar, from 88.2 c. to 87.5 c.; Peru, sol, from 81.2 c. to 80.6 c.; Russia, rouble, from 65 c. to 64.5 c.; Tripoli, mahbub, from 73.3 c. to 72.7 c.; U. S. of Colombia, peso, from 81.2 c. to 80.6 c.

A REVIVAL OF ancient art is vigorously setting in throughout Japan, as sensible natives are beginning to see the evil effects of Western influence in deteriorating the true national style. Now the Japanese are eagerly looking up their old artistic heirlooms, and taking care that such treasures do not pass into European hands for a few pence only. In order to raise the public taste, also, exhibitions are to be held in the chief cities of the best works of the old Japanese masters, the series having been opened by a display in Yokohama of some 120 pictures by Tanin, who lived more than two centuries ago, and is considered one of the great native painters.

THE TRADE of New York importers with Canadian buyers is likely to receive a serious blow from the latest revision of the Canadian customs laws. The Parliament of Canada at its last session enacted that *ad valorem* duties shall be imposed upon the value of goods when sold for consumption in the country whence they were exported direct to Canada. This is nothing but an indirect and most reprehensible method of handicapping United States merchants in their competition with those of Europe for the Canadian trade. It adds to the confusion previously existing in our commercial relations with the Dominion the spice of malice penance.

[Copyright Secured.]

### The Cup—Its Art and Customs.

[BY JOHN W. MILES.]

Continued from page 396.

FROM THE different Anglo-Saxon wills and inventories one may gather some idea of the value placed upon all forms of drinking utensils. "In one will three silver cups are bequeathed; in another four cups, two of which were of the value of four pounds; in another four silver cups, a cup with a fringed edge, a wooden cup variegated

with gold, a wooden knobbed cup and two very handsome drinking cups. Other similar documents mention a golden cup with a golden dish; a gold cup of immense weight, a dish adorned with gold, and another of Grecian workmanship (probably from Byzantium). A lady bequeaths a golden cup weighing four marks and a half. In 833 a king gave his gilt cup, engraved outside with vine dressers fighting dragons, which he called his cross-bowl, because it had a cross marked within it, and it had four angles projecting also like a cross. The Lady Ethelgiva presented to the Abbey of Ramsey, among other things, 'two silver cups for the use of the brethren in the refectory, in order that while drink is served in them to the brethren at their repast my memory may be more firmly imprinted on their hearts.'\*\* Horns also were used for drinking, and were often very elegantly mounted. "In the will of one Saxon lady two buffalo horns are mentioned. Three horns worked with gold and silver are mentioned in one inventory, and we find four horns enumerated among the effects of a monastic house. The Mercian King Witlaf gave the Abbey of Croyland the horn of his table 'that the elder monks may drink from it on festivals, and in their benedictions remember sometimes the soul of the donor.'† It was customary among the Anglo-



Enameled Cup, A. D. 1350. (English) Figure 50

Normans for "the lady of the house, however high her rank might be, occasionally to fill the cups of the guests, and on the chessmen of the 12th century the 'queen' usually carries a drinking horn. Some of these chessmen are still preserved."‡

In the 11th century we find the custom of pledging introduced among the English, but for a different reason than those of earlier nations. At this period England was under the dominion of the Danes, and it is said to have been common with the invaders to stab a native while in the act of drinking. If indeed an Englishman presumed to drink in the presence of a Dane without his express permission it was esteemed so great a mark of disrespect that nothing but instant death could expiate it. No Englishman, therefore, drank

\* Homes of Other Days.

† Ibid.

‡ The History of Drink.

in company, even on invitation, without some Dane present would give his pledge of honor that he should not be hurt.

During the reigns of Henry III. and Edward I., enameled cups were brought into England from Rome and France, particularly those of the manufactory at Limoges, and this importation was largely increased after the conquests in the latter country by Edward III. As among the Greeks and Romans, these cups were known by different names, such as standing cups, hanaps, colettes, argueries, flacons, drageours, etc., and they were usually of very high value. An enameled cup of the 14th century, belonging to the corporation of Kings Lynn in Norfolk, figure 30, represents the prevailing style of enamel work of this period. The goblet is divided into five compartments. These contain figures one above the other dressed in the costumes of the century. They are of silver with a background of dark blue, green or purple enamel. Portions of the costumes are also enameled. Of the work of this century there is a beautiful wassail horn at Queen's College, Oxford, presented by Queen Phillipa, figure 31. It is now used as a loving cup. The horn is Buffalo and surrounded with three silver gilt bands with the word "wacceyl" engraved three times upon each. Connected with the two lower bands are bird's-claw feet, upon which it rests. The small end ter-



Wassail Horn at Queen's College, 14th Century, Figure 31.

minates in a monster's head. This can be removed and the horn sounded, and as, according to the statutes, the students were to be summoned at the sound of a horn, this horn may have been used for



Cawdor Horn, (Temp. Henry VII.), Figure 32.

that purpose as well as for drinking. The celebrated Cawdor horn is much more elaborate, having a foot of silver upon which rests the

horn between the royal supporters, figure 32. It is said to have been the "first drinking vessel used by Henry, Earl of Richmond, after landing in England in 1485, and presented by him to David up Evan, son of Roderick the Great, who lived at Llwyndofydd in Llandisiliogogo, and there entertained the Earl and his men in his expedition against Richard III."§



Mazer, (Temp. Richard II.), Figure 33.

The introduction of Christianity did not alter the custom of wassailing, but rather gave it a religious aspect. The wassail bowl or cup became a part of the table furniture in the great monasteries, and received the name of "Poculum Caritatis," which may be freely translated a grace cup or loving cup. Or if used exclusively for secular purposes it often has religious inscriptions or mottoes. A very popular kind of drinking vessel of the olden time of "Merrie England" was the Mazer bowl, an illustration of one dating in the 15th century being given in figure 33. They were made of wood,

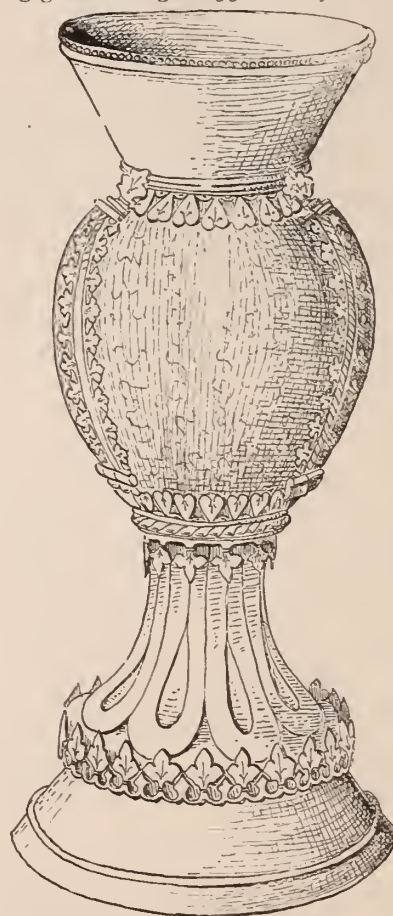

Cocoa-nut Cup at Oriel College, Oxford, Figure 34.

usually maple, and mounted at the rim in gold or silver. The larger bowls, holding half a gallon or more, were on feet. Handsomely polished they formed a very beautiful cup, and the metal work was often richly chased, while engraved on the bottom St. Christopher appeared before the eyes of the wassailer as he finished the bowl. The one figured bears the legend

"In the name of the Trinitie  
Fille the kup and drinke to me."

§ Old English Plate, Page 218.

While the "treen" cups were used by the lower classes the nobles and wealthy people had cups of costly material and great magnificence. The splendor of the cup was an evidence of the rank of its possessor, and if not always entirely of the precious metals was formed of some other rare and expensive material. The egg of the ostrich or the shell of the cocoa-nut upon a silver foot and surrounded with silver bands were often used and highly prized. The cocoa-nut especially commended itself to the early goldsmiths on account of its shape and durability. Being very rare they were of great value. There is one at the Oriel College, Oxford, presented by Bishop Carpenter in 1470, and set in silver gilt. Figure 34 is a representation of it. Another at New College exhibits a tree growing within a paliade and having six branches enclosing the bowl with foliage. Unfortunately the examples of cups belonging to this period are very few. The Wars of the Roses were as fatal to their preservation as the Reformation was to ecclesiastical plate, but such as we have bear unmistakable evidence of Gothic influence without that transition stage which, in Italy, was classed as *quattrocento*. The changes gradually taking place in other countries seems to have been unnoticed by English artists. The grand awakening of the renaissance changed the character of English art like a revolution, leaving clearly defined lines to mark the ending of the old and beginning of the new styles. Perhaps the latest specimen of Gothic work in silver gilt is the well known Leigh Cup at Mercers Hall, London, and dating 1499-1500, figure 35. The foot rests upon three flagons, and the lozenge-shaped



Leigh Cup at Mercers Hall, London, Figure 35.

panels, formed by cross bands, are ornamented with flagons alternating with maiden's heads. It is surmounted with a maiden seated and holding a unicorn in her lap. Around the cover and bowl are bands of blue enamel, bearing the following inscription in silver letters:

"To elect the master of the Mercerie hither am I sent,  
And by Sir Thomas Leigh for the same entent."

The Gothic character of the cresting is very strongly pronounced, and the entire production is a very elaborate piece of workmanship.

(To be Continued.)

## The Horological School at Glashutte.

To the Editor of the Jewelers' Circular:

DEAR SIR:—In your issue of November I notice queries concerning the German Horological School at Glashutte, and their contents make me believe that some ample information about this matter may be welcome to part of your readers. I wish you would lend the publicity of which you dispose to the following lines.

INFORMATION ABOUT THE GERMAN HOROLOGICAL SCHOOL AT GLASHUTTE, SAXONY.

### Extract of the Regulations of the School.

1. The School receives young men which are desirous of acquiring the art of horology or improving in the same.
2. The instruction afforded by the School is theoretical and practical.
3. The practical exercises of the attendants consist in completing and improving their own tools, making models of escapements and apparatus for the illustration of certain horological problems, making various parts of movements in connection with the watch manufacture of our place, making astronomical clocks and marine chronometers, timing and adjusting fine watches, constructing and calculating horological mechanism of all kinds, etc.
4. Besides this, the School can provide thorough instruction in making and improving watch jewels, repeater work, lever escapements and compensation balances by renowned specialists. The School is also prepared to make its attendants acquire a practice in the latest attainments in electro-mechanics.
5. The theoretical instruction involves arithmetic, algebra, geometry, plans and spherical trigonometry, analytical geometry, the elements of differential and integral calculation, drawing, natural science, mechanics, theory of horology, the elements of chemistry, book-keeping, French and English languages. All the theoretical instruction is kept in intimate relation to horology.
6. The time devoted to theoretical instruction is 2 hours a day as a maximum. All the rest of the day is filled by practical occupations.
7. The regular yearly course of instruction begins with the 1st of May, and with respect to the theoretical studies it is advisable to enter at this time. However, attendants are received at any other time, and if they cannot be assigned to any theoretical class, they are instructed only in practical work and in drawing.
8. The School can be used in different ways, and we distinguish in this respect:
  - a. *Apprentices*, which are those attendants not having any practical attainments in our trade, or not having practiced in it for at least 2 years. They have to engage themselves for a stay of 3 years.
  - b. *Scholars*. In this quality the School admits young men who have been practicing in our trade during 2 years at least. They enter for a stay of 1 year, which may be prolonged at liberty.
  - c. *Guests*. Those who have been practically employed in our trade for more than 4 years are received for a stay of 6 months at least. As a rule they do not attend to theoretical lessons except drawing.
  - d. *Hearers*. There are young men sojourning here and attending merely to theoretical lessons or to drawing classes.
9. The categories under *a*, *b* and *c* are submitted to the discipline and regulations of the School.
10. The School fee is to be paid quarterly in advance. Every attendant of the categories *a*, *b* and *c* is bound to pay the school fee for the full extent of his obligatory stay, if there are no forcing motives for a premature leaving.
11. The School fee for apprentices and scholars who are subjects of the German Empire is 180 M. (4 marks=1 doll.) yearly. For guests it is 150 M. for the obligatory 6 months and afterwards 18 M. a month.
12. These amounts increase by 20 per cent. for attendants of for-

eign nationality. (This must not be considered an unfriendly or prohibitive measure. The expenses of the School are by far higher than the income by the fees. The balance is established by a subvention of the Government of Saxony and a contribution of the German Watchmaker's Union. If, therefore, an attendant of foreign prossuience pays 20 per cent. more, he is still far from covering his share of the expense.)

13. The work done by the attendant is his property, and if it consists in repairs, etc., the value of it is put to his credit.

14. A special class is arranged for repairing. Here, as far as the School is provided with work of this kind, the attendants are intrusted in replacing or improving escapements of lever or detent watches, parts of complicated mechanisms, etc.

15. Every attendant must have his own set of tools. Anything required for this purpose may be had here in good quality and at moderate price under the control of the School.

16. A note containing the estimation of diligence and progress in the different branches of instruction is given to each attendant at the close of each quarter. Those who have filled their obligatory term, receive a certificate on leaving the School.

To the above extract of the regulations I wish to join some explanatory remarks:

Any young man coming here to attend our school ought to be steady in his habits and diligent, so as to make the best of his stay for his own interest and for the credit of the School.

Those who have decided for the watch and clock making trade had better enter as apprentices. No private workshop can afford the same facilities in practical and theoretical instruction as a school exclusively devoted to this purpose.

The Council of the School is prepared to accommodate young men in board and lodging with respectable families of our town at the price of 40 to 50 M. a month.

Thus the yearly expense of a young man here runs about as follows:

|   |          |
|---|----------|
| School fee, yearly.....                         | 216 M.   |
| Board, lodging, washing, heating and light..... | 670 "    |
| Clothes, books, pocket money and sundries.....  | 124 "    |
|   | <hr/>    |
|   | 1,000 M. |

From this may be subtracted the value of his work.

For those who are coming here without any tools it will require 300 to 500 M. to fit them out, but this sum is not wanted at once.

Those who could not afford the passage over here and the above expense, would, if they are competent practical workmen, attain their purpose as nearly as possible by taking a situation in one of our manufacturing houses and attending to the theoretical lessons. Then they will earn for their own work what it is worth here and thus defray part of the expense. I am quite willing to assist them in these endeavors.

There is certainly a difficulty to be overcome for those who do not know the German language. We receive scholars without any knowledge of our language, but in their own interest I would advise those intending to come here to learn as much of the language as they can beforehand, as it will prove a great convenience and advantage to them in their studies here.

Boys who are willing to enter as apprentices, ought to be sent, if possible, to a good school at Dresden to complete their general instruction, and at the same time acquire the language thoroughly. If a boy of 12 or 13 years, instead of finishing his school term in his country was sent to a good school at Dresden or some other German town, it would prove a very good plan. There are many American and English lads in German boarding schools, and I am quite ready to recommend a good school and to settle the preliminaries.

Those who come here without any knowledge of the German language had better come 6 or 9 months before the beginning of the regular course (1st of May), so that they can acquire the language by private lessons sufficiently to follow the theoretical lessons.

The climate of our place and district is very healthy and similar to that of the State of New York, except the summers which are not so hot. Glashutte is situated in the valley of a small river at the foot of the high mountains separating Saxony from Austria (Bohemia). Gymnastical exercises and pedestrian excursions establish the necessary bodily development.

Saxony is a Protestant country, but places of Catholic and Israelite worship are not far from here.

The School building is very well adapted to its purposes; the working and teaching rooms are spacious and well lighted.

The School is now in the middle of its 6th year of existence. Last year it has been visited by 56 attendants, without the hearers. Of this number 11 were from foreign countries.

I wish to add some words on my personal relation to our School. By numerous queries received, I see that it is generally believed that the School is my private enterprise and belongs to me. This is an error; the School has a public character and I have not the slightest material or financial interest in it. I am carrying on my watch manufacturing business as before, but since the foundation of the School I have been entrusted with the presidency in the Council of the School and with the general superintendence of it. All communications bearing on receptions of scholars, etc., ought to be forwarded to me. Address: M. Grossmann, watch manufacturer, Glashutte, Saxony.

Parents wishing for references about our School may apply to the following persons: Mr. Taylor Smith, watchmaker and jeweler, Whitewater, Wis., whose son has been here these 18 months; Mr. A. C. Smith, General Manager of American Watch Co., New York; Mr. Henry A. Norman, watchmaker, corner of 4th and Main streets, Cincinnati, O., who knows the School by own inspection, and Mr. Ernst Schaefer, a former scholar of our School, now in Warren, Pa. Glashutte, Saxony, Dec., 1883. M. GROSSMANN.

### American Gems and Precious Stones.

*A Paper presented to the United States Geological Survey by George F. Kunz.*

*Continued from Page 388.*

*Isopyre.*—Isopyre\* is found in small veins from one to three inches in width at the iron mines near Dover, New Jersey. In color it very nearly resembles the darker green jasper, or, in other words, blood-stone without the red spots. It is used only as a gem in the cabinets of collectors.

*Prehnite.*—Prehnite† has been found at a number of localities in the United States, and gems have been cut from material found at Bergen Hill and Paterson, New Jersey.

*Zonochlorite.*—Zonochlorite has been found only at Neepigon bay, Lake Superior, and is scarcely known as a gem, except to collectors, some of the specimens showing the rich dark-green tints, arranged in concentric layers, and are very beautiful.

*Turquoise.*—This stone has been found at three localities in the United States—Los Cerillos, New Mexico, Turquoise mountain, Cochise county, Arizona, and at a point in Southern Nevada. At the latter place it occurs in veins of small grains in a hard shaly sandstone. The color of this turquoise is a rich blue, almost equal to the finest Persian, and the grains are so small that the sandstone is cut with the turquoise in it, making a rich mottled stone for jewelry. The principal sale for this stone is in San Francisco. At Los Cerillos some pieces have a decided blue color when found or broken but show a marked tendency to turn green, and usually become quite green in a very short time.

At Turquoise mountain the normal color appears to be green, although at times a faint shade of blue is perceptible.

\* Collection of F. A. Canfield.

† Collection of G. F. Kunz.



[Prof. W. P. Blake writes to the *American Journal of Science*, March, 1883, concerning this new locality of green turquoise, as follows:

"In this *Journal*, March, 1858, I directed attention to the occurrence in New Mexico of a green turquoise highly prized as a gem by the aborigines and known as '*Chal-che-we-te.*' The completion of the railway along the valley of the Rio Grande has made the Cerillos mountain, in which the gem occurs, much more accessible than it was, and the ancient mine has been re-opened and worked to some extent by Eastern capitalists, as made known by Professor Silliman. The stone is in consequence more abundant than before, and at Wallace Station on the railway very good specimens can frequently be obtained of the Pueblo Indians.

"I have recently visited another locality where chalcuite occurs and was mined by the ancients. This is in Cochise county, Arizona, about 20 miles from Tombstone, in an outlying ridge or spur of the Dragoon mountains, and not far from the stronghold of the Apache chief, Cochise, so long the terror of that region. This elevation is now known as the 'Turquoise mountain,' and as there are several deposits of argentiferous ores near it, a mining district has been formed called the 'Turquoise district.'

"At the turquoise locality there are two or more ancient excavations upon the south face of the mountain, and large piles of waste or *débris* thrown out are overgrown with century plants, yuccas and cactaceæ. It has not been worked for a long time, and probably never by the Apaches. The excavations are not as extensive as at Los Cerillos, and it is more difficult to find specimens of the mineral. It is evidently much less abundant than at the New Mexican locality. Enough of the gem was obtained, however, by searching in the waste heaps, to show that it is identical in its appearance with the New Mexican chalcuite. The rock is also similar, and the chalcuite occurs in seams and veinlets rarely more than an eighth or a quarter of an inch in thickness.

"The color is light apple-green and pea-green, precisely that of the New Mexican stone, as generally seen. There is in some fragments a faint shade of blue as at Los Cerillos, but the true normal color appears to be green rather than blue.

"The specific gravity I find to be, of two different fragments, 2.710 and 2.828. The first was slightly porous and earthy, and the second dense, hard and homogeneous. These results are higher than I obtained with the specimens from the surface at the New Mexican locality, viz., 2.426 to 2.651. Two determinations recently made gave 2.500 as the specific gravity of two partly-cut stones from the old Cerillos locality."

Mr. F. F. Chisolm furnishes the following additional particulars concerning the New Mexican turquoise:

"Turquoise is found in the Rocky mountain division only on Mount Chalchihuitl, in Santa Fé county, between the Santa Fé and Galisteo rivers, about 20 miles southeast of Santa Fé. The mountain is composed of eruptive rocks, probably of Tertiary age, and is distinguished from the other peaks of the Cerillos range by its white color. The origin of the Los Cerillos turquoise, in view of late observations, is not doubtful. Chemically, it is a hydrous aluminum phosphate containing 3.81 per cent. copper. Neglecting this constituent, the formula for turquoise requires, phosphoric acid, 32.6; alumina, 46.9; water, 20.5.

"Evidently the decomposition of the feldspar of the 'trachyte' furnished the alumina, while the apatite or phosphate of lime, which the microscope detects in thin sections of the Cerillos rock, supplied the phosphoric acid. It seems probable that the bluish-green color of the mineral is due to the associated copper, which is derived from the copper ores occurring in the Cerillos mountains.

"The turquoise occurs in thin veinlets or concretions throughout the mass of yellowish white rock. The concretions or 'nuggets' are covered with a crust of nearly white aluminous rock, and on being broken generally afford the commoner and less valued varieties of the stone, such as are cut roughly and sold on the Atchison,

Topeka and Santa Fé trains by the Indians at the towns of Wallace and Algodones. Fine stones of sky-blue color and of considerable value are extremely rare, and many tons of rock may be broken before finding a stone which could be classed as a gem.

"The observer is deeply impressed on inspecting this locality with the enormous amount of labor which in ancient times has been expended here. The waste or *débris* excavated in the former workings covers an area of at least 20 acres. On the slopes and sides of the great piles of rubbish are growing large cedars and pines, the age of which must be very great. That considerable quantities of the stone have been obtained can hardly be questioned. The early Mexican settlers attached great value to the turquoise, as do the Indians of the present day. It is a matter of history that these mines were well developed in 1680, in which year a large section of the mountain suddenly fell in as a result of undermining the mountain by the Indian miners, killing a considerable number of them."

All the American turquoise is sold to either tourists or collectors, or in the jewelry trade only as oddities. The material cut and sold as gems annually amount to about \$1,500. That cut into specimens and sold amounts to fully as much more.

*Labradorite (Labrador spar).*—Labrador spar is found in large quantities in Lewis and Essex counties, New York, and in bowlders all the way down to Long Island and New Jersey in the drift from the New York counties named above. It is scarcely used at all in the arts; owing to the cheapness and superiority of the same mineral from Labrador.

*Amazon stone.*—Pike's Peak, Colorado, and several localities in North Carolina, furnish this mineral, which is often cut and is generally used in cheap and tourists' jewelry. The quantity of material thus cut and sold amounts to over \$1,000, while that sold as mineral specimens brings probably two or three times that amount.

*Sunstone.*—Sunstone of very good quality, almost equal to the Norwegian, is found at Media, Delaware county, Pennsylvania, and at Orange Court-house, Amelia county, Virginia. It is as yet used to a very limited extent, and the annual sales may amount to about \$250.

(To be Continued.)

## Practical Treatise on the Adjustment of a Four-Jewel Cyl-inder Watch.

[First-Prize Essay by HERMANN HORMANN.]

Continued from page 408.

When it can be done, a bracing spring of brass foil is laid upon the hour wheel, especially by watches with second hands.

131. If the wheels of the minute work are rough or simply filed, as it occurs with very ordinary watches, or if their finish or polish has suffered by stretching, rounding, etc., their good appearance is restored nicely by grinding them.

There are several methods for doing this, of which the following are the ones mostly employed. Upon a glass plate oilstone powder and oil are stirred together, and the two lower faces of the wheels are first ground nicely. Both wheels are placed upon turning arbors, and ground flat upon their surface, for which a glass plate with holes is used, which is also supplied with oilstone powder. After having washed the two parts with benzine, a very handsome flat and white ground surface will appear; it must not be touched with a dirty brush, since it easily becomes filthy.

132. The other method is as follows: The two wheels, placed upon turning arbors, are introduced between the centers of the turning tools, when they are ground upon both sides with a small water stone or slate.

It is almost unnecessary to mention that any occurring burr must be removed from the wheel teeth of the minute work; in case also the depths were good by rounding with a small rounding file, or

by means of a brass scratch-brush; this must also be the first when examining the minute work. Also examine well that the parts of the minute work do not scrape in their sinks, and, if it should occur, it is to be done away with by turning out.

CHAPTER XI.

THE CYLINDER WHEEL.

133. Having arranged the center wheel, barrel and minute work, they are taken down and the cylinder wheel is inspected next.

Every workman will acknowledge that the fourth wheel depthing can never be arranged correctly until the cylinder wheel has not been uprighted. For this purpose try it alone in the plate.

134. It is a frequently occurring defect of new watches that the cylinder wheel scrapes with its bottom upon that of the recess in the plate, or with its teeth under the bridge. Too little is also often turned out near the lower jewel hole, so that the pinion faces rub upon the brass. The wheel must first be uprighted before the correction of the other defects is attempted.

135. The uprighting of the cylinder wheel, if a new jewel setting is not to be made, or the bridge stretched, cannot be done in any other manner than by displacing the latter. For this purpose take down the wheel, and with a chamferer make room for the bending of the foot pins; next screw the bridge again in place, and leave the screw rather loose. If, now, the wheel is to be brought a little lower in front, place a brass punch to the bridge behind at the edge of the plate, and strike light taps with a small hammer upon it. Then tighten the screw, and test the effect by placing a fine pivot broach through the two jewel holes. If the broach still inclines a little toward behind, the correction has not been sufficiently strong and must still be increased. But if the wheel hangs over forward the bridge screw is removed, a punch fitting into the screw hole of the bridge is picked out, and with this the bridge is driven a little back. Should the wheel incline toward this or that side, proceed in a similar manner (also see Art. 38). Accompanying sketch shows the form of the punch and its use. The method is useful in so far as by it the foot pins stand straight in their holes, and have only above between the plate and bridge a small and more or less

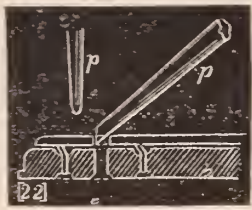

noticeable bending; the bridge sits flat, is not cramped, and may correctly be arrested and taken down; while a bent foot pin always produces more or less tension, and also the pin holes are partly injured by the filing or oblique broaching.

The manner of treatment is in accordance with the degree of solidity of the bridge and its deviation. If the bridge stands shaky, another foot pin is to be drilled in.

136. When the wheel hangs straight, observe its passing through under the bridge which must be as full as possible, since, without taking into account the possibility that the wheel may scrape there, oil will easily collect at this place, and intermixing dust and fibers can produce irregularities in the rate of the watch.

If there is too little space for its passage, cement the bridge upon the plate of the universal tool and turn off a little additionally. Should the wheel be still liable to scraping in the plate, also correct by turning.

The shake of the arbor may be regulated by bending the bridge, especially when the bridge is very thin, or if only little change has to be made in the end shake. There are various other means, however. It is not always advisable to file out of the plate, because the bridge very easily is screwed on insecurely thereby. The creating of burr by hammering or cutting belongs to the domain of botch-work; if employed for inferior watches, the highest places of the burr should be passed over with the polishing file. The best means to give more or less shake is the drilling in of pins which I also recommend. Especially for the adjustment of fine watches, this method should always be employed (Art. 160 to 162).

137. It is important to pay attention to the jewel holes of the wheel as well as of the cylinder, whether they are not bursted or are rough within, whereby the pivots are worn and ruined in a short time; this must be examined with a strong magnifier.

Obliquely set as well as obliquely drilled jewel holes accelerate the wear of the pivots, and for the former it is advisable to turn a new setting, and for the latter the substitution of a new jewel hole.

138. The diameter of the hole must from  $1\frac{1}{2}$  to 2 numbers be larger than that of the pivot measured by the pivot gauge. For measuring the holes, small so-called gauge arbors of blue annealed steel in the form of accompanying figure are used. In the middle of the arbor is a brass plate bearing stamped in the number of the arbor.



With due experience, the greater or less play of the pivot in its hole may be seen both by the eye and felt with the fingers.

139. Badly polished or unduly thick pivots are to be re-polished. The difficulty of polishing the upper cylinder wheel pivot (which by the present height of cylinder watches should not exist at all), is done away with by the use of the here sketched pulley, the arrangement of which is as follows: A steel roller *a* is on its front side gently rounded off; upon this is fitted a hollow turned disc *b*, which, by means of two countersunk screws, can be screwed tightly upon the former. The cylinder wheel is now placed between this turned out disc and the arched side



of the roller. After fastening the disc by means of the screws, the tooth rim is entirely pressed back and the pivot protrudes freely. The disc *b* must naturally be so thin in its middle near the hole that it does not project beyond the shoulder of the upper pivot.

140. When the pivots are polished they are left of a length of twice or thrice their diameter, and their ends are rounded off. No matter what pivot of a watch it be, it is to be polished and rounded off in such a manner that it do not scratch the finger nail.

Both the shoulder and the arbors of the wheel must not be too thick, since it makes the wheel heavier uselessly and increases friction. For that purpose, a cone, that is, a bevel, is turned on on both sides which decreases the frictioning surface of the shoulder; also grooves are turned on the arbor which are for the purpose of retaining the oil, so that it does not run along on the arbor or in the pinion.

141. When the condition of the cylinder wheel, as well as the pivots of their jewel holes, is correct, the fourth wheel, together with the cylinder wheel, are mounted and the depthing is examined.

The defect sometimes occurs that the scape wheel teeth, in consequence of proportionately too small a fourth or too large a cylinder wheel, scrape on the fourth pinion. This is corrected by turning down at the place on the pinion where the scraping takes place. Should the third wheel seize exactly at this place in the fourth pinion, then the former must correspondingly be set higher or lower as shown in fig. *A*; if of a large quantity the wheel is to be

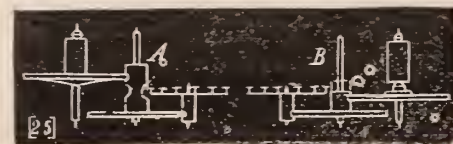

taken down and the pinion shifted. If the fourth wheel pinion of itself is rather short, and the cylinder wheel teeth gear in at its upper end, it is to be made still lower, and the third wheel is also set lower or else a brass collet is fitted on upon which the wheel is riveted, which case is illustrated by fig. *B*. Should, however, the disproportion be too great, and that also the balance scrapes on the fourth wheel arbor, then the fourth wheel must be replaced by a larger one, and, if necessary, also the scape pinion is to be renewed if it is not preferred to mount a new balance.

142. If the depthing is too deep, only the fourth wheel is to be rounded; while, if too shallow, the depthing has to be made with the depthing tool; beside this, a new and larger wheel is to be mounted. When the depthing is to satisfaction, the insufficiently polished pivots are to be polished, and, if necessary, the holes are to be bushed, which in the specified case must be done truly eccentrically.

(To be Continued.)

## Jewelry.

### THE NEWEST STYLES IN THE SETTING OF PRECIOUS STONES.

THE FINEST jewels are brought from every clime to deck American ladies, and gold is colored and shaped to suit the taste and complexion of the fastidious wearers. Novelties in these costly ornaments are constantly appearing, which have emanated from the busy brain of the designers. Wild flowers and grasses are reproduced in the richest and rarest of gems that conceal a fortune beneath their dainty petals. The stiff set designs of the cross and locket have been superseded by ornaments which are copies of birds, flowers and foliage, bees and butterflies. The rare and beautiful ruby and the white and colored pearls are at present the fashionable stones. Emeralds that have so long been out of date have again regained their popularity and are consequently very expensive. Dark beautiful sapphires are much used with rubies and diamonds, and topazes, sapphires and diamonds are associated to produce Oriental colorings. Canary diamonds of darkest shade, and colored pearls, both pink and black, are set with diamonds.

Real India jewelry (manufactured in New York) is put up in India silk and brocade cases, or very odd shaped leather cases; necklaces of beads and bracelets of this soft gold are much liked. The bracelets are in most curious designs of twists and chains which are liked for the novelty. Some of them are formed of pieces of gold the size of a ten cent piece linked together with a gorgeous spider of precious stones imbedded in the gold. Ear rings and chatelaines are also made of this dull yellow gold.

Bracelets are almost indispensable with the present style of ladies' dress sleeves. Link or chain bracelets are again fashionable, made of square, oval and faceted links, twisted wire and the different kinds of curb and cable chains. The chain bracelets of India design are made of dull, yellow gold. Flat linked bracelets have a jewel in each link, as a diamond, ruby, emerald or sapphire. Many of the bracelets are fitted with a clasp that makes them cling to the arm, but the newest devices for closing them do away with the ordinary clasp entirely; one of the latter style is formed of several fine chains no larger than a cord, each of which terminates with a pendant ball, and seems to be only carelessly wound around the arm and tied in a loose knot. Another of this sort is of woven gold wire that encircles the arm, and is so soft that it needs only to be pressed on the arm to hold it in place. The serpentine bracelets with corrugated folds are not at all like the serpent bracelets now considered passé. Bangle bracelets too, are fast losing favor. Band bracelets, when worn at all, are worn very narrow. Three narrow bands each set with a different kind of jewel, are very beautiful for the arm. A very pretty bracelet, and one which is particularly so on a round white arm, is made of a fine chain with a slide and two or more balls as pendants. Some of the balls are plain colored gold, while others are ornamented with Etruscan and set with various stones. All bracelets in coil shape and made of 22 karat gold are so soft that they may be made to fit any part of the arm. A dainty little bracelet which is entirely new, brought out within the last few days, is a new wire of gold no larger than the finest steel knitting needle. It has a spring that draws back and contracts after being put on the arm. They are ornamented with a pendant diamond, ruby, emerald, sapphire, or else have a drilled pearl which revolves on the wire. A slender row of emeralds, rubies or diamonds makes a handsome bracelet, and

two linked together and worn on a band of black velvet at the throat are very stylish and elegant. One of the handsomest bracelets of this kind is a chain with a diamond in each link and a pendant pearl. A diamond merchant remarked, as he held up a bracelet made of round, flat pieces of dull gold linked together: "Last year these were the 'swell' bracelets, this year they are the style." In two of the center pieces spiders, formed of the richest and rarest gems, are sunk into the gold. There are also bracelets of hammered gold and half beads linked together. Pretty and simple designs are seen in the cheaper bracelets of twisted gold cord. The cheapest of all bracelets are the fine wire ones of red gold.

For ladies, rings with the smallest possible rim of gold showing around the stones and passing around the finger are the most fashionable. Some of the finest gems set in rings have a band of small diamonds passing nearly around the finger. Rubies, which are much more rare and equally as expensive as diamonds, are set in this way. All fanciful stones fancifully set are in favor. Pearl rings of different colors, as the gray, bronze, pink, black and the solitaire white pearl are popular; emeralds, spinelles, cat's-eyes, aquamarines, sapphires, rubies and tourmalines of different colors are seen set with diamonds; many of them in the Elizabethan style, while others are in a cluster. At present the fancy is for a combination of stones in a ring instead of a solitaire, although the solitaire diamond still remains the favorite engagement ring; these have only a mere thread of gold showing, no matter how small the stone may be. Gypsy rings, with the stones deeply imbedded in the gold, which were originally intended only for gentlemen, are now as often chosen by ladies. As a whole, these are not so massive as those worn by gentlemen. They are rounded bands of gold and may have a ruby, sapphire, cat's-eye or any other stone in the center with a diamond on each side. The stones are so buried in the gold that only the surface shows. Stones *en cabochon* (polished, but not cut), are very effective set in this way. The value of such a ring, of course, depends entirely upon the stone selected. A very pretty ring for a young lady is a diamond set with a pearl on each side. Seal rings for ladies with a jasper, blood stone, onyx, sardonyx and other stones set in red, yellow and plain gold in novel patterns are to be seen. Wedding rings are of 22 karat in half oval form and rather small; this is now considered the orthodox style.

Necklaces are no longer fashionable, and when worn only serve to mar the effect of a stylish costume, although for full dress occasions those formed of precious gems are admissible. Broad bands of velvet or those of medium width, with a tiny gold chain or a row of diamonds to be worn outside of the dress band are stylish. A fanciful pendant of gold studded with jewels, as a wild rose, a star, a cross, a beetle or a butterfly, are handsome. There are beautiful ornaments which can be worn as a pendant, lace pin, or can be pinned anywhere on the dress to hold drapery or jabots of lace in place. A beautiful pin or pendant of this kind is a beetle with the body formed of one large pearl, with the head of diamonds and wings of rubies and diamonds. Marguerites, with white or yellow enameled leaves, have red, cinnamon colored or rich brown diamonds for the center, to be worn either as a pendant or a lace pin. Jointed bands of diamonds with pendant pearls are also worn on these velvet bands at the throat and are becoming alike to blondes and brunettes; zircons, chrysoberyls and aquamarines handsomely set, make beautiful ornaments or pendants. Apple blossoms of pink enamel, delicately shaded with diamond centers, are among the prettiest and daintiest ornaments seen. Ladies of wealth choose a string of nicely matched pearls with a diamond clasp or pendant. These rows of gems for the neck can also be worn as bracelets.

Sets of jewelry with a brooch and ear rings to match, are no longer fashionable. Solitaire diamonds are the handsomest of all ear rings, and are set with as little gold showing as possible. Sapphires, emeralds, rubies, pearls or cat's-eyes are often set with a row of diamonds encircling them. Solitaire, ruby and sapphire ear rings are also very beautiful. Diamond earrings are worn with a lace pin of any design,

in fact they are often designed expressly for the wearer. Ear rings in simple designs of plain or colored gold, ear knobs in form of balls and other devices and ornamented with Etruscan tracery and hoops of plain and hammered gold are popular. Faceted gold balls and plain gold balls set with diamonds, pearls, rubies, sapphires or turquoises are pretty for young ladies, as are also those of ivy leaf, geranium, clover and fern leaves naturally tinted. Buttercups and daisies made to set close against the ear are very pretty. There are also pretty pearl ear rings, simply set or in flower designs; these may be worn with lace pins to match, but are more frequently seen with pins of a different design. Very pretty pins are seen of colored gold or else handsomely enameled. White daisies and purple violets are seen with diamond dew-drops, which look as though they had just been brought from the meadows. Long bar pins still continue the popular style of lace pins, or else they are in fanciful designs which destroy the regular outline. Flowers, animals, birds and heads of animals are quite common, while golden buttercups, daisies, sunflowers, pinks, clover leaf, lions, dogs, cats, tigers, owls' heads, cocks' heads and swallows are closely copied in gold. Ladies also wear pins suggestive of racing, yachting, boating, lawn tennis, archery, croquet, bowling and all sports the same as those worn by gentlemen for scarf pins. There are also pins with tourmalines, garnets of every variety, moon stones, topazes and turquoises. Katydid's of curiously colored gold for a lace pin are among the latest novelties; also a trident with two shells of diamonds attached to it, and a shepherd's crook with a diamond star fastened on it, or the crook is of diamonds with a star set with rubies.

#### JEWELRY FOR GENTLEMEN.

For evening dress gentlemen wear a short vest chain of fine gold, or else a long chain doubled to pass across the front of the vest. All watch chains are still very small, like slender cords of gold. Chains are of plain red and colored gold or platinum, and are of fine cable or curb links. Linked sleeve buttons of the yellow gold made in India designs are in various shapes and set with a variety of stones such as a pearl, sapphire, diamond, cat's-eye or a tourmaline. Some are merely blocks of gold fastened together. Scarf pins for gentlemen are in every conceivable design. Spiders of colored pearl or of gold, animals' heads of enamel or jewels, palettes, musical instruments, antique coins, masks, vases, whips, designs emblematic of sports, gunning, polo, archery, yachting, fire-arms, frogs and many cunning French designs, which are always popular, beside a bewildering array of knots. One hundred different kinds of gold knots, some containing a jewel, are shown for scarf pins, but the latest in these curious complications of gold cord are those copied from the garments of the Korean Embassy who visited New York a few months ago. The knots worn by these Celestials on their clothing are reproduced with great accuracy in gold to ornament the cravats of American gentlemen. Beetles, white violets, pansies, harps, the crescent, signal lights made of different stones, yellow sapphires, spinels, etc., set with diamonds, and pearl headed pins in colors are seen among them. Seal rings for gentlemen are worn smaller than heretofore and with less gold showing. Rings of hammered platina with a brilliant diamond in gypsy setting are odd looking, as the metal resembles silver somewhat. A single large diamond held with four chains of dull India gold makes a very handsome ring. Scroll settings are also much liked. Seal rings with a sard, jasper, tourmaline, amethyst and topaz have various settings. Mythological, historical and classic subjects are usually chosen for intaglio rings. A ruby, cat's-eye, sapphire or diamond are all seen in the gypsy rings and many of the less costly gems.

#### CHATELAINES AND WATCH CHAINS.

Watch chains for ladies, which are both safe and useful, are only about eight inches long with a small bar at one end to fasten in the button hole. There are still shorter chains which answer the same purpose. Some of the latest ones have a charm of India design handsomely set with jewels or brilliantly enameled; usually these chains correspond with the watch they are attached to. For ladies under forty the chatelaine is still the fashionable guard. Very handsome short chains have a jewel set in each link, which add much to the beauty and price of it.

#### Pocket Compasses.

"WHY DO you keep so large a stock of compasses?" an old gentleman asked, as he ran his eye over rows of compasses of all sizes and qualities which were spread out in a show case in a down-town sportsman's supply store. "You seem to have enough to supply a dozen navies, while this neighborhood seems the last one in the world that sailors would frequent."

"I don't recollect ever selling one to a sailor," the salesman said, as he rubbed the finger marks off the barrel of a pistol with a piece of chamois skin.

"Who buys them?" the old gentleman asked.

"Chiefly persons engaged in mercantile pursuits and boys. It stands this way: When a young clerk or a business man goes into the country for a week's or even three days' vacation, he generally thinks that a compass is as necessary as a fish line. Boys always buy them when they go away from home. You see they have visions of getting lost in dense forests, or of being carried out to sea in open boats. It don't make any difference where they are going, even if there isn't a forest for miles around, and the largest body of water in the neighborhood is a goose pond."

"Some years ago," the old gentleman said, musingly, "I bought a compass. I was going on a hunting expedition in the northern part of the State. There were half a dozen of us in the party, and we were in for a real good time. None of us had ever been in that region before, but we had heard that it was a first-class place for small game, and that deer were not unusual to say nothing of an occasional bear. We hired a guide, but did it merely as a matter of form, for all of us, I believe, were fortified with compasses which we considered as a safe preventive against getting lost. Well, the first day after we had struck a camp I started out on a tour of investigation. I had a double-barrelled fowling piece hoping to bring in a brace of birds. I had not been out long before I discharged both barrels of the gun but did not kill anything. When I went to load again I found that I had forgotten to bring along any ammunition. I suppose I had then walked for nearly an hour, and had not taken the straightest course in the world. As near as I could calculate I must have been three or four miles from the camp. While discharging my gun I had turned around, so when I concluded to return I did not have the clearest idea in which direction the camp lay. I was not a bit worried for I had every confidence in the compass which rested snugly in my pocket. I took it out and looked at it. The needle pointed to the north, and the dial gave me an excellent idea of where the other points lay. That was about all. Whether I was north, east, south or west of the camp I did not know."

"What did you do then?" said the salesman.

"Oh, I just sat down at the foot of the tree. It seemed better to have the guide hunt for me, as he knew the place better than I did. At the end of five hours I heard his gun bang a few hundred yards away and called out. I haven't put much confidence in compasses since."

"You made a mistake in not taking your bearings before you left camp," put in a young man who had just purchased a pedometer.

"I have heard a good deal about taking bearings," the old gentleman said, "but I never had a clear idea how it was done. I'd feel obliged if you would explain it to me. Now, before leaving camp what would you have done?"

"I'll tell you in a second," the young man replied. "Now, suppose I wanted to go east from the camp. I would take out my compass and mark a line running north and south. Then I would stand on this line facing the east, and would hold the compass in front of my breast. Then I would walk forward. Whenever the needle deviated I would know if I were out of my way."

"Wouldn't holding the compass in front of your breast make you a little tired?" the old gentleman asked.

"Not at all. Compasses are not very heavy."

"How about coming back?"

"The easiest thing in the world," the young man said, his supe-

rior knowledge beaming from his face. "I would just put the compass on the ground, walk around it, and then return in the same manner as I had come."

"There is no doubt that you would arrive safely at camp," the old gentleman said, "although your movements to make the scheme a success would have to be a little contracted. Doubtless you would lay the compass on a stone while you shot at a passing bird."

"A cross-eyed man," remarked the salesman, "would have a great advantage in traveling in this way. He could keep one eye on the compass, and have the other looking out for game."

"Your purchasing a pedometer," the old gentleman continued, turning toward the young man who took bearings, "reminds me of an occurrence of which I was a witness in the Catskill Mountains. I was in the waiting room of a hotel near Tannersville, talking to the proprietor, when a gentleman walked in. He seemed to be about 35 years of age, and his face wore a very serious expression. He said:

"You told me this morning that the mountain I have just climbed was 1,423 feet high."

"So it is," the hotel man asserted. "It is so in the guide book."

"Both you and the guide book are wrong," the serious man said. "The height of that mountain is 1,419 feet. I measured with this altitude measure."

"He showed us something like a glass tube filled with water, in bottom of which was a flaky white sediment."

"You said," he went on, "that it was a mile and three-quarters to the foot of the mountain. My pedometer registers twenty-two yards more than that distance, and according to my compass your statement that the mountain runs north and south is equally inaccurate, as the needle shows it to be a trifle to the northeast."

"But to return to the subject of pocket compasses," the salesman said. "There have been great improvements in their manufacture in the last few years. We have them cased in brass, in German silver, nickel-plated, and even in gold and silver so that they may be worn as watch charms. Some of the needles are balanced on steel points, some on agate and some on crystal. Some are set in open faced cases, and some in hunting cases just like watches. The prices vary anywhere from 25 cents to \$20."

The young man who knew how to take bearings bought a large double-cased nickel-plated compass as a set-off to the pedometer.—*N. Y. Times.*

### Graduating Thermometers.

"WHEN A thermometer is to be made," said a manufacturer, "the glass-blower first blows a bulb on the end of a long tube. While this bulb is hot the end of the tube is inserted in mercury, and as the bulb cools the mercury rises and fills the bulb. This process is repeated until the bulb and part of the tube are filled. The bulb is then immersed in snow or chipped ice and the mercury settles to the freezing point, which is marked on the tube as 32° if a Fahrenheit scale is to be followed. Next the bulb is put in boiling water and the point to which the mercury rises is marked on the scale as 212°. Ten degrees of the mercury are now detached from the column by jarring and the whole length of the tube is tested. The process is repeated with five degrees of the column being measured all the time by a standard thermometer to see if the tube is conical at any point."

"Are common thermometers usually correct?"

"They generally vary about two or three degrees, owing to the irregularity of the opening in the tube, which causes the mercury to rise slowly where the opening is too large and too fast where the opening is too narrow. It requires great skill to blow a tube with a uniform opening the whole length."

"Are thermometers ready for use immediately after they are filled with mercury?"

"They should be allowed to stand not less than one month—one year is better—to allow the mercury to settle before the scale is made."

"What are the different kinds of thermometers that are made?"

"The self-registering thermometer is used for marking the highest and lowest points reached within a given time. The bulb is filled with mercury, above which, in the tube, is inserted a fine piece of steel spring; the remainder of the tube is filled with carbolic acid or creosote. The steel spring rests at the highest point it is pushed to by the mercury and is afterwards drawn down by a small magnet. By a duplex arrangement and reversing the scale the lowest or coldest point is indicated in the same way. The deep sea thermometer is of the same pattern and is incased in a heavy copper tube to preserve it against the pressure of water. It has, besides, a self-regulating attachment. The fever or clinical thermometers are made with great nicety and are used for determining the temperature of the human body."

"What is used for filling the bulbs of thermometers?"

"Mercury is commonly used it being highly sensitive to heat and cold, but for the extreme northern climates it will not answer, as it freezes at 40° below zero. Where this temperature is liable to be met spirit thermometers are used, being made of alcohol colored red or blue. These spirit thermometers will not answer for high temperatures, however, as the alcohol volatilizes too readily."

"Is there a Government standard for testing thermometers."

"There is no Government standard. The Signal Service uses the Fahrenheit scale. The Winchester Observatory of Yale College has established a Thermometric Bureau for testing thermometers either for dealers or others interested in procuring exact instruments. A small fee, ranging from fifty cents to \$2 is charged and a Yale certificate of correctness is furnished. The observatory has elaborate apparatus for testing thermometers and its services are of great value to physicians in testing clinical thermometers. The observatory has issued a circular to physicians which contains the following statement: 'The competition of business, coupled with the entire absence up to this time with any large observatory in this country paying special attention to thermometry, to which authoritative appeal could be made, has so affected the manufacture of thermometers for medical purposes, that it seems necessary to issue a card briefly indicating the errors commonly found to exist, and to explain why in this case the representations of the dealers may be at fault through the want of a proper understanding of the subtle errors to which medical thermometers are liable. Too great a desire to economize time, good material, and skilled labor has led in the making of thermometers to the following faults: (1) The graduation is sometimes started from one point of the scale near the normal, and the size of the capillary tube is guessed at. No upper point being fixed by the maker, the higher graduations may be erroneous to the extent of several degrees. (2) Too much air separating the index from the column of mercury causes the index to rise with a jerky motion; air above the index forces the index down when the thermometer is taken away from the body. In some thermometers errors from this cause amount to two degrees at high temperature. (3) New thermometers increase their readings rapidly during the first months after manufacture, so that instruments which were right when made may change their indications as much as two degrees within a year.'"

"Are there any late improvements in thermometers?"

"In the old style of clinical thermometers there was a small space of oxygenized air separating the column of mercury that held the upper portion of mercury at the maximum point; now a contraction is made in the tube that retains the mercury at the maximum point until it is jarred back to its place. There is also a new style of plain thermometer made with an elongated bulb with the tube balanced near the center on a pivot. As the mercury rises above the pivot the point of the tube is depressed and moves along an index like the hand of a clock. This thermometer can be read with ease

across a large hall. There are also many new contrivances for registering degrees of heat and cold with clock attachments to indicate the hour the temperature indicated was reached. Thermometers are also made with wire attachments, so that the mercury rising to a certain point will touch the wire and complete the circuit of a galvanic battery and sound an alarm. These are useful in the drying rooms of paper manufactories, in green houses and as a provision against accidental fire."

### How Hard Money is Made.

"WE DON'T make money here," said Philip Van Wyck, the courteous Chief Clerk of the Assay Office, "that is, we don't convert bullion into coin. We receive gold and silver from depositors, melt and assay the bullion, form it into bars and ship the bars to the Philadelphia Mint, and in the course of a few days that institution sends us back the coin."

"But does the depositor have to wait for payment until the coin gets back from Philadelphia?" asked the reporter.

"Not at all," said the Chief Clerk; "the Government furnishes us with a bullion fund amounting to over \$35,000,000, out of which we pay the depositor just as soon as the fineness of his metal is determined by assay, the weight ascertained and the value calculated. In fact, all our deposits, except in cases of re-melt and re-assay, are made within two days.

"Now," said he, picking up a bright new double eagle, "you know how easy it is to spend that coin, but unless you are familiar with the work you can form no idea of the time and labor it took to make it. From the time the bullion from which this double eagle was made reached the mint until it was converted into coin, it had passed through no less than ten distinct processes such as melting, alloying, forming the metal into ingots, rolling the ingots into strips the thickness of the coin, cutting from the strips the 'planchets' or 'blanks,' annealing, milling and adjusting the 'blanks,' and coining or stamping the pieces, besides sundry minor operations incidental to minting. Now, examine that coin closely under the glass and see how well the work is executed. The Romans excelled in the art of engraving, and many of their coins were masterpieces. But we cannot afford to throw up our central designs in such bold relief as the Romans did, for in the hurry and bustle of our day and the rapid handling and piling of coins, we would soon wear the face off of the goddess and the wings off of the eagle. So while our designs are in bold relief, yet we make them low and protect them as much as possible from abrasion and wear by 'throwing up' the edge of the blank technically called 'milling.'

"The manufacture of dies, or the art of 'die sinking' has reached great perfection at the Philadelphia Mint," continued Mr. Van Wyck, "and all the coinage dies for other mints are made at that institution. The artist first makes the design and then a model of it in wax three or four times larger than the desired coin. From this model an electrotype is taken, and then the design is transferred by means of a Hill engraving machine which works on the principle of a pentograph, to a block of steel the size of the coin. But as only the principal design, such as the head, eagle or shield can be thus transferred, the artist fills in by hand the stars, date and all surrounding details. Then after removing the ground on the face of the block, he strikes from the block an impression into and upon a second block. This second block is hardened and an impression is transferred to a third similar block which we call the 'parent die' or 'master hub,' and from which the regular coinage dies are made. The impression on the 'master hub' is in relief or convex, while that on the 'working' or coinage die is in 'intaglio' or concave.

"But let us see what they are doing in here," said the chief clerk as he stepped into the "weigh room," where truck loads of silver were being weighed. "That scale you see there is a model of accuracy, and will weigh from ten thousand ounces down to the one-

hundredth of an ounce. This small balance weighs from twenty ounces down to the one-five-thousandth part of a grain. In fact, we must have accuracy in this work, not only to check our operations, but to maintain the reputation of this office, which is such that our stamp of weight and fineness passes current in all the commercial centers of the world."

### Old Silver Divested of Romance.

"OLD SILVERWARE and Jewelry Bought," is painted in large black letters over the doorway of a gloomy looking store in a down-town street. A counter and a close wire grating divides the interior. A brown-bearded man was behind the counter when we entered. To his right on the counter lay a heap of silver butter knives, spoons, forks and other silverware, while resting on a stool a few feet off was a great iron pot about two-thirds filled with lumps of silver. Alongside of the pot stood a machine with a long iron handle, by which silverware could be crushed.

"What can I do for you?" the man asked, showing his face at a little arched opening in the wire grating.

"Tell me who sell old silverware and jewelry, and what kind of old silverware and jewelry they sell."

"There are so many people who sell that I hardly take notice of them. Once in a while a character comes in, and by sheer individuality attracts attention. The goods usually brought in are old-fashioned or worn out and broken."

"Do not wealthy persons who are pressed for money, try to sell their jewelry or plate?"

"Not to us. We only pay for the weight in metal, and do not take into consideration the workmanship or appearance. When persons to whom you refer want to dispose of their jewelry or plate, they go to a pawn shop where they can generally raise more money on them than we would pay for them. Then, you know, they can redeem them at any time. I have known instances where articles sold for their weight have been pawned for a higher figure. Wealthy people often bring in old-fashioned goods which cannot very well be pawned."

"What is characteristic of your customers?"

"They all think that they should receive three times as much for their goods as we are willing to pay. They generally sell, though, but have on their faces as they go out a deeply injured expression. We often get hold of curious things, some of which are valuable. Some years ago a well-dressed gentleman came in carrying what seemed to be a large case wrapped in paper. When he took the wrapper off it turned out to be a scabbard of a sword. It was solid silver and beautifully engraved. He said that his father had captured it from a British lord in the battle in which Burgoyne surrendered. The Englishman's crest which had adorned the hilt of the sword, the gentleman's father had had removed, and had his own name engraved in its place. I paid about \$90 for the scabbard which was the value of its weight in silver. It must have cost at least \$500. The gentleman probably thinks that it is melted up but it isn't. I have kept it for nearly eighteen years as a curiosity."

"Do you save many of the articles you buy for the purpose of selling again?"

"Not often. Sometimes a friend comes in and asks me to save for him a set of spoons or forks. Most of the stuff we get is melted."

"Do you ever buy plated goods through mistake?"

"Sometimes we do, but not much. Occasionally, in buying a large lot of silver spoons, knives and forks, one or two plated ones are run in on us. Here is a pair of sugar tongs which we bought for silver and which are a magnificent imitation. They are of an old-fashioned pattern and very thickly plated."

"How do you tell that an article is silver?"

"By its weight and general appearance. It is rare that we have to use the file. I can't tell you all the points by which the real are distinguished from the imitation. It is an almost instinctive knowledge which guides one. Gold articles are always tested with acids, which vary in strength, so as to accord with the different amounts of the baser metals with which the gold is alloyed."

"Are your customers chiefly men or women?"

"Mostly men. Women often come in with one or two old spoons or forks; they rarely bring any considerable quantities. Auctioneers often buy large lots of old silverware which they are glad to sell for its weight, and on which they make a good profit. An old man once brought here a lot of old silverware that was perfectly black. Probably it had come in contact with sulphur. We gave him close to \$100 for it. He said that he had been to an auction sale where he had bought the lot for \$2, thinking, as everybody else did, that the ware was pewter."

---

### Venetian Glass.

THE *American Magazine of Art* describes "Venetian Glass," its origin and popularity, and, among other interesting things given in it regarding the subject, are these:

The spell of Venice possibly owed some of its power during the Middle Ages to the subtle beauty of those numberless objects of glass ware, silent witnesses to her superior handicraft, which her far-reaching commerce carried to the utmost limits of the world. Certainly no manufacture since classical times had ever achieved so widely extended or so lasting a renown as the far-famed glass of Venice which Coccio Sabellico, in 1495, describes as comprising "all things that can attract or delight the eyes of mankind." Amongst our national treasures there are few objects that we children of a later day have endeavored more earnestly, or perhaps more successfully, to emulate than these bewitching phantasies. History rarely keeps record of the beginning of famous manufactures, and of the origin of Venetian glass we have no certain knowledge. The interest of this subject has led various writers to devote themselves to the elucidation of its early history. Professor Zanetti, director of the Correr Museum at Murano, is the highest authority in Italy, and the modern revival of this ancient art owes much to his learning and patient research, while in England we are greatly indebted to the zeal and learning of Mr. Franks and Mr. Nesbitt. Native historians assert that the art was practiced in the lagoons of Venice as early as the fifth century. It is possible that refugees from Italy, some of them experienced in an art then practiced universally in Rome and other cities, may have remarked the extraordinary natural advantages possessed by the lagoons for the manufacture of glass—the abundance of fine sand and maritime plants yielding alkali—and turned these rich gifts to such a use. Doubtless the existence of these natural advantages contributed later to give Venice her superiority. In the days of her after renown, not content with her native productions, she sent her boats to the classic river Belus to gather and bring back the sand celebrated by so many pagan writers. Documentary evidence only begins 1083, Professor Zanetti having lately discovered in the archives of Murano a paper of that date relating to trade regulations in glass making.

The increasing importance of the industry began to attract the attention of the Great Council, and many laws were made regulating the trade. In 1275 an edict prohibited the exportation of sand or any substance used in making glass, or even bits of broken glass, though masses of glass might be imported as ballast. By these and similar devices the republic strove zealously to guard from the outer world the secrets of a manufacture which brought her citizens such gain. Though Venice gave her name to all the glass objects, the factories, for fear of fire, were banished the city in 1291, makers of small wares being allowed to remain on condition that fifteen paces

were left between their workshops and houses. In 1159 we find one Pietro, whose name sounds Italian, at work upon mosaic. The taking of Constantinople (1204) sent many Greeks to Venice, and they doubtless brought much additional knowledge to the factories already established. The glass treasures of St. Mark's are supposed to be part of the plunder of Constantinople. They are the most clearly marked specimens of Byzantine work known. Twenty years after (1224) we read that twenty-nine *phiolari* were reprovved for breaking the official regulations laid down for the management of the works. Some years later, in the procession at the Doge's election, the glass workers exhibited decanters, scent bottles and so forth; and soon afterward, by a decree of the Senate, they made measures and weights of glass of the same kind as those issued by the Fatimite princes and thus proved to admiration how much more they were influenced by Byzantine than Roman traditions. The earliest specimen of Murano glass known to exist is the Marriage Cup in the Correr Museum, with enameled portraits of a man and a woman. This is attributed to Beroviero, 1450. The two beautifully enameled cups from the Slade bequest in the British Museum, the "Triumph of Venus" and the "Marriage Cup," are of the same class. They were at one time bought for £3 12s. and £3, and were among the gems of Prince Soltykoff's collection. They were acquired by Mr. Slade for £238 and £161. Their present value is much greater—it is said that £3,000 has been offered for the famous Byzantine *tazza* of St. Mark's. All these vessels, enameled with armorial bearings, saints or grotesque figures, belong to the fifteenth or early sixteenth century, and all show the influence of Byzantine art. The plate bears the arms of a doge of Venice, 1501. Among the subjects figured is one representing St. George and the dragon, and one with the winged lion of St. Mark's. These enameled objects, requiring the aid of skilled artists, must always have been rare and expensive. A cheaper style was afterwards adopted, when the ornaments were simply painted in oil colors on the glass. This class of work is distinguished by a great deal of very delicate gilding and jewel pattern. The great advance made by the art in Murano about this date and afterward may be attributed to the artistic impulse given by certain families who transmitted their secrets from generation to generation. The effects of this inherited dexterity may still be seen in some of their descendants, who are among the most skilled artisans of modern Murano.

---

### The Treatment and Working of Precious Stones.

[By A. WAGNER, in *Erfindungen u. Erfahrungen.*]

WITH REGARD to the polishing of jewels, crystalline stones are generally cut in such a manner that they represent bodies bounded by plane faces. Precious stones which decompose the light and therefore produce a play of colors and fire, are polished in such a manner as to increase this property as much as possible. This is accomplished by giving them a large number of facets; for instance the brilliant.

Precious stones which are not crystalized, and are distinguished by their special play of colors—opal—or by their peculiar effects of light—cat's-eye—are usually polished half round or half oval, of the shape of a loaf of bread or half of egg.

Precious stones are set in two styles: the open setting (*a jour*) and the box setting (*en casette*). In the former, the jewel is exposed on all sides, and only retained by claws; all its properties, the play of colors and fire, are shown to best advantage. Hence, valuable jewels are never set in any other manner. Flat jewels, which are set in rings, are sometimes not retained by claws, but embraced around their circumference so as to leave only the top and bottom exposed.

With the box setting, the stone forms, as it were, the lid to the gold box, and such jewels in case they are transparent, are generally polished thus that the upper face is flat and smooth, while the lower one is a truncated pyramid.

The beauty of a stone set in box and of an inferior value, is sometimes increased by lining the box with colored tinfoil, the color of which corresponds to that of the stone. For instance, a dark yellow foil is laid under a very pale topaz, a deep violet one under a very pale amethyst, etc., and in this manner the light reflected from the box will show a deep yellow or violet color, whereby the beauty of the stone is much enhanced.

In setting ordinary stones for cheap goods the box is not even lined with colored foil, but it is simply given a coat of some appropriate varnish. This process cannot be recommended, however, since stones underlaid with foil are of a far handsomer appearance.

In order to produce a cheap article which at the same time shall be ornamented with a genuine jewel a trick of trade is resorted to: Thin slips of the genuine jewel, for instance, emerald, are on one side coated with a glass mass the color of which is exactly the same of that of the slip, after which the glass mass is polished.

When such a stone is set, the thin slip of the jewel is turned outward, and the glass mass within, whereby it shows the valuable properties of the corresponding jewel at least on the surface. Such conglomerations are called "underlaid gems," "pierres fines doublés," or "doublets." When such underlaid jewels are set skillfully, they are distinguished with difficulty from genuine stones by experts even.

They can easily be recognized, however, by holding the stone before the eye in such a manner that the light falling upon its surface enters the eye at an obtuse angle; the faces of contact of the jewel and glass can in this way be distinctly seen, on account of the difference in the refractive power of both, and a non-expert may think it to be a split. Unscrupulous dealers will often sell such stones as genuine, and the ignorant purchaser is frequently swindled thereby.

---

### What is Going on in the World of Science.

—Delaurier describes in *Les Mondes* a new system of concentration of solar heat. The principle is that if the air be heated in a closed space, the hottest layers rise to the upper parts, and in this region the temperature will rise more and more if the calorific action be prolonged, and suitable precautions be taken against cooling. Thus, if the inclosure have the form of a pyramid or a cone, an apparatus, both curiously and variously useful, may be had at little cost. M. Delaurier uses a double envelope of glass with a layer of air in the interval. On the shaded side the outer envelope is covered with light wooden shutters coated with bright metal. This arrangement is especially useful for winter or a cold climate. At the center of the apparatus, on a wooden base, are fixed vertical radiating partitions of copper blackened by oxidation, and on the edges of these are cemented the trapezoidal plates of glass which form the first envelope. The apparatus is not hermetically closed below. M. Delaurier considers that it would, besides being industrially useful, make an excellent pyrheliometer.

—In the course of a lecture on gold, delivered before the Franklin Institute, as reported by the Secretary, Mr. A. E. Outerbridge, Jr., of the Assay Department of the Mint in Philadelphia, gave an account of some experiments he had made, with a view of ascertaining how thin a film of gold was necessary to produce a fine gold color. The plan adopted was as follows: From a sheet of copper rolled down to a thickness of  $\frac{5}{1000}$ ths of an inch he cut a strip  $2\frac{1}{2}$  by 4 inches. This strip, containing 20 square inches of surface, after being carefully cleaned and burnished, was weighed on a delicate assay balance. Sufficient gold to produce a fine gold color was then deposited on it by means of the battery; the strip was then dried without rubbing and re-weighed, and found to have gained  $\frac{1}{100}$ th of a grain, thus showing that one grain of gold can, by this method, be made to cover 200.

—Some attempts have been made in London to photograph the human vocal organs in the act of singing. The principal object was to obtain a picture of the ligaments known as the vocal chords, which are situated at the top of the larynx. These can be viewed in the laryngoscope, a small mirror, which when placed at the back of the throat serves at once to reflect light upon the membranes, and to form an image of them visible to the observer. With the aid of this instrument numerous observations have been made upon singers, and much valuable information has been collected, but all previous efforts to obtain a photograph by substituting a camera for the observer's eye have entirely failed. The difficulties were overcome by the use of a powerful Siemens electric lamp, supplied by a dynamo machine. By means of this light some excellent photographs were obtained of the laryngoscopic image. The patient in each case was Herr Behnke, at whose instance the experiments were made.

—Paper in a variety of forms, which shall be both luminous and proof against damp, is made up of the following substances: Water, 10 parts; paper pulp, 40 parts; phosphorescent powder—by preference slacked for 24 hours—20 parts; gelatine, 1 part; and saturated solution of bi-chromate of potash, 1 part. The gelatine resists the damp and the phosphorescent powder secures luminosity.

—This is the receipt for agate glass: Ten parts of broken glass are melted, and to it are added 15 parts suboxide of copper, the same quantity of the oxides of chromium and of manganese, .02 part each of oxide of cobalt and nitrate of silver, .01 of uranium, 4 reargols and .3 part bone-meal. Each oxide is added separately and at intervals of 10 minutes. After heating the mixture for an hour, .3 or .4 part of fine soot is put in.

—Prof. Kalischer, who has been making an extensive series of researches on the structure of the metals, concludes that most of the metals are naturally crystalline, and that when the crystalline structure has been lost by mechanical treatment it can in most cases be restored by the action of heat.

—Metallic iridium is very hard. It easily cuts or marks steel. It can be cut by a copper disk revolving at a very high velocity, if the surfaces in contact are treated with corundum and oil and the iridium sheets are very thin.

—To drill glass, M. Gougy, of Paris, recommends that a three-cornered saw-file be sharpened in the usual way, but with one corner taken off, so that the cross section of the drill near the point is that of a truncated cone, and the end of the drill is of narrow chisel shape.

—A writer of mathematical bent, says the *Scientific American*, finds from the census returns that there are about 17,000 dentists in the United States, who, he estimates, pack into the teeth of the American people a ton of pure gold annually. Continuing his speculations, he predicts that in the twenty-first century all the gold in the country will be buried in the graveyards.

—To make a bronze that shall be as elastic as copper, from 1 to 2 per cent. of mercury must be added to it, according to the degree of malleability desired. The mercury may be combined with one of the metals of which the bronze is made before making the alloy, or introduced to the melted mass that already contains the different metals in the proper proportions.

—The aluminum process for the decoration and preservation of iron and steel is intended to take the place of nickeling, tinning and coppering. The coating leaves the sharpness of the outline unimpaired, and adheres closely to cast and wrought work.

—In the stores of Paris glass is taking the place of wood for flooring. It costs more than wood, but it lasts longer, and besides being easily kept clean allows enough light to be transmitted through its roughened surface for the employés to work by in the floor beneath. The glass is cast in squares and set in strong iron frames.



## Tempus Edax Rerum.

A COMPLIMENTARY banquet to the foremen of the various departments of the Waltham Watch Factory was given at the Parker House, Boston, on the evening of January 5.

The following gentlemen were present: Royal E. Robbins, Daniel F. Appleton, E. C. Fitch, A. L. Dennison, H. N. Fisher, F. W. Freeman, Stedman H. Hale, A. C. Smith, R. E. Robbins, Jr., W. H. Fitzgerald, C. Burnham, P. W. Carter, J. L. Keyser, H. M. Haines, D. W. Eldridge, J. N. Hammond, L. Greene, D. O'Hara, C. Hicks, M. Thomas, H. Bond, C. Moore, J. E. Searing, C. H. Taisey, N. P. Malloy, C. F. Berlin, J. Sawin, C. Olney, H. Buncher, W. Murray, C. Mann, G. H. Shirley, J. J. Lynch, T. Gill, D. H. Church, W. Wills, J. T. Shepard, W. H. Wrenn, E. A. Marsh, E. J. Hull. D. F. Appleton, Esq., of New York, presided during the first part of the evening, Mr. H. N. Fisher, president of the foremen's association, filling the chair, by invitation of Mr. Appleton, during the latter part of the entertainment.

The tables were elegantly adorned with flowers and smilax, and everything passed off satisfactorily and to the entire and hearty enjoyment of every person present. The gentlemen began to assemble at six o'clock and indulged in social intercourse in the reception room until seven o'clock, when they were invited to the spacious dining room, the procession being headed by Messrs. Robbins and Appleton. Mr. A. L. Dennison, popularly known as the "Father of watchmaking in America," was a guest, as were also Mr. R. E. Robbins, Jr., Mr. P. W. Carter, clerk of the corporation, Messrs. D. W. Eldridge and C. H. Taisey, of the Boston office, and Mr. W. H. Fitzgerald of the Chicago case factory.

The banquet was a culinary success and received full justice at the hands and stomachs of the guests. When cigars were introduced Mr. D. F. Appleton, in a short but feeling address, wherein he reviewed the history and early struggles of himself and Mr. Royal E. Robbins in founding the American Watch Company. He paid a high tribute to the indomitable perseverance, energy and skill of Mr. Robbins in the management of the mechanical department of the business, and in surmounting the innumerable obstacles that presented themselves from time to time.

Mr. Robbins was visibly affected by the kindly remarks of his distinguished partner, and the kindly demonstrations evoked by them from all present. After recovering himself he replied to Mr. Appleton in a happy vein, relating his experiences and his first efforts to systematize watchmaking, referring in brief to the difficulties he had to encounter and overcome in the early struggles to establish American watchmaking on a firm and enduring basis.

Mr. Dennison was then introduced to the foremen as their chief—historically speaking. He replied at length, giving a full account of his apprenticeship and his first thoughts in regard to the system of watchmaking which he inaugurated in this country.

Mr. E. C. Fitch, having been eulogized by Foreman Fisher when he took the chair on Mr. Appleton's retiring, responded in a few brief and terse remarks, thanking the foremen for the generous support they had given him in the performance of his duties as superintendent of the factory. He complimented them on the personal interest they had taken in not only increasing the product of the factory but in elevating the standard of the work so that every watch now turned out by the Waltham factory bears testimony to the integrity of the men who made it. He also gave a general outline of what would be expected of them in future. His remarks were listened to with the closest attention by all present, and when he resumed his seat he was greeted with vigorous demonstrations of applause.

Mr. S. H. Hale, the company's representative in the west, being called upon, responded with that flow of language and modest eloquence for which he is noted. He spoke of the excellence of the goods turned out at the factory, and of the improvements that are being steadily made, which not only command the attention and approval of the trade but of the public in general as well. He was

glad to be at any gathering of the employees of the Waltham factory but especially at a gathering where a bountiful banquet was provided as on the present occasion.

A. C. Smith, from the New York office, also spoke of the improvements in the quality of the goods produced at the factory, and complimented the gentlemen present for their fidelity.

Speeches were also made by several of the foremen, most of them being of local significance, referring directly to the daily routine of life at the factory. Some of them were exceedingly witty, but their local application renders them lacking in general interest. At the conclusion of the banquet the foremen returned to Waltham on a train specially provided for the occasion, after having spent a most agreeable evening in social intercourse with their employers and companions.

## Seventh Annual Meeting of the Jewelers' League.

THE JEWELERS' League held their seventh annual meeting at Horticultural Hall, on Tuesday evening, January 15th; a large attendance of members were present. The meeting was called to order by the President, Gilbert T. Woglom. After stating the usual order of business to be transacted during the evening, the President made the following brief address:

"Gentlemen and fellow members: It is with more than an ordinary feeling of gratification that we greet you all to-night, fellow members of the Jewelers' League, in annual session; such a large assembly of members of the jewelry and kindred trades is now possible only in our League. The past year has been unusually prosperous and satisfactory, as will be shown to you in the detailed reports of the Secretary and the Executive Committee. Our growth has been steady, our low death rate has been phenomenal. It speaks well for the industry and faithful interest of the members that we now stand a society numbering 3,003 members, and not a dollar having been expended in fees or commissions for securing a member. It speaks well for the care exercised in admitting members that you have had but four deaths during the year of 1883, a space of seven months during the year having elapsed without a death occurring. It speaks well for the accomplishment of the purposes of our League that the benefits since organization, including the two in course of collection at this time, amount to \$73,670.10. We must speak kindly and thankfully of the liberal firms in our trade who gave us their interest in the unused balance of the Chicago Fire Fund, which, thanks to the indomitable perseverance of the counsel of the League, coupled with the merely nominal contest made by the trustees in whose keeping it had lain during the last ten years, it has been faithfully secured, and to the amount of \$4,938.53 will be placed in the permanent fund of the League to-night. [Applause].

Let us also thank Isaac M. Miller for his happy thought and example in making the League his beneficiary. If his example were followed by nineteen other liberal-minded men, the League would in time be in possession of a fund of \$100,000 for the special purpose of relieving the necessities of aged and indigent jewelers, otherwise for the permanent fund. On April 2 of last year was passed by the Legislature of our State, an act entitled Chapter 175 of the Laws of 1883, embracing all the features which experience has proven are essential to the welfare of our mutual benefit societies, giving us adequate protection, effectually barring all such speculative societies as have brought disgrace upon neighboring states, and wholesomely restraining such as are inclined to operate in the interest of speculators within our border. The League is entitled to credit for the interest and effort taken in assisting in its behalf toward securing the passage of that act by its officers."

Mr. Woglom then went on to state the importance of the members selecting the very best men possible to fill the various offices about to become vacant. Showing by quoting extracts from a circular sent by Supt. of Insurance, John A. McCall, Jr., to the Union

Mutual Benefit Associations, and from the annual report of the Chief Registrar of Friendly Societies, the vital importance that their officers have sound views on, and keen discrimination between, the methods and operations of charitable and benevolent organizations and the speculative co-operative concerns.

Mr. Woglom closed his address by thanking the members for their forbearance and courtesy to him as President during his term just closed. His address received the close attention of the members and was frequently applauded.

The reading of the minutes of the last annual meeting being dispensed with, the reports of the Examining Finance Committee, and Secretary and Treasurer, were submitted and adopted as follows:

|   |     |       |
|---|-----|-------|
| Membership of League, January 16th, 1883.....                   |     | 2,344 |
| Applications received during year 1883.....                     | 715 |       |
| Applications rejected " " " ".....                              | 31  |       |
| Applications referred for investigation, (not yet accepted).... | 9   | 40    |
| Members accepted during the year.....                           |     | 675   |
| Members dropped for non-payment of assessments.....             | 14  |       |
| Members resigned.....   | 2   |       |
|   |     | 16    |
| Members reinstated, (who had been dropped in former years)..... | 6   | 10    |
|   |     | 665   |
| Members died during year 1883.....                              | 6   |       |
| Net increase during year 1883.....                              |     | 659   |
| Total Membership at date.....                                   |     | 3,003 |
| Members died since organization, June, 1877.....                | 25  |       |
| Members resigned " " June, 1877.....                            | 3   |       |
| Members expelled " " June, 1877.....                            | 1   |       |
| Members dropped " " June, 1877.....                             | 57  | 86    |
| Total Membership number.....                                    |     | 3,089 |

|  |               |               |
|--|---------------|---------------|
|  | GENERAL FUND. | BENEFIT FUND. |
| Amount on hand January 16th, 1883..... | \$3,009.07    | \$4,453.60    |

RECEIPTS.

|  |            |           |
|--|------------|-----------|
| 675 Members' Initiation Fees, at \$3.00.....     | 2,025.00   |           |
| 675 Members' First Assessments, at \$2.00.....   |            | 1,350.00  |
| Amount from Reinstatements.....                  | 224.00     |           |
| Interest on Deposits at Union Trust Company..... | 131.71     |           |
| Coupons from Government Bond.....                | 2.00       |           |
| Assessment Number 20.....                        |            | 5,108.00  |
| " " 21.....                                      |            | 5,258.00  |
| " " 22 and 23.....                               |            | 11,020.00 |
| Total Amounts to Credit of Treasury.....         | \$5,391.78 | 27,189.60 |

DISBURSEMENTS.

|   |            |            |
|---|------------|------------|
| Beneficiary of M. W. Jackson.....           | \$4,892.50 |            |
| " Chas. F. Livermore.....                   | 5,000.00   |            |
| " W. J. Doherty.....                        | 5,000.00   |            |
| " L. A. Cuppia.....                         | 5,000.00   |            |
| Commissions of Secretary and Treasurer..... | 1,135.80   | 21,029.30  |
| Amount in Benefit Fund.....                 |            | \$6,160.30 |

MISCELLANEOUS.

|  |           |          |
|--|-----------|----------|
| Books, Stationery and Printing.....                                  | \$ 666.64 |          |
| Postage.....   | 327.15    |          |
| Rent of Post Office Box.....   | 16.00     |          |
| Rent of Office, 61 Nassau Street.....                                | 300.00    |          |
| Expenses of Office.....  | 34.12     |          |
| Fuel, Gas and Ice.....   | 27.29     |          |
| Insurance Department of State of New York.....                       | 25.00     |          |
| Union of Mutual Benefit Associations.....                            | 81.17     |          |
| Services of Attorney.....  | 130.52    |          |
| Mercantile Safe Deposit Company.....                                 | 2.00      |          |
| Stenographer for Annual Meeting, 1884.....                           | 10.00     |          |
| Hire of Hall for " " " ".....  | 35.00     |          |
| " Camp Stools for Annual Meeting, 1883.....                          | 6.00      |          |
| Subscription to <i>Underwriter</i> , \$5; <i>Guardian</i> , \$2..... | 7.00      |          |
| Commission of Secretary and Treasurer.....                           | 112.45    | 1,780.34 |

|                             |            |
|-----------------------------|------------|
| Amount in General Fund..... | \$3,611.44 |
|-----------------------------|------------|

|                               |            |
|-------------------------------|------------|
| Total Amount in Treasury..... | \$9,771.74 |
|-------------------------------|------------|

\$50 Government Bond held in trust for Executive Committee.  
WM. L. SEXTON,  
Secretary and Treasurer.

Amount paid to date on Assessments 24 and 25....\$3,500.00  
Duly attested by the Examining Finance Committee,  
CHAS. G. LEWIS, C. G. ALFORD, GEO. R. HOWE.

The Annual Report of the Executive Committee was next read by Mr. John D. Lyon, Chairman of the Committee. The following are liberal extracts from the report:

"Your Executive Committee presents to you this, its Seventh

Annual Report, and in so doing congratulates you on the rapid strides the League has made, and the substantial basis that has been attained during the year. \* \* \* The amount paid beneficiaries of deceased members from organization to January, 1883, was \$53,777.60; during this year, \$19,892.50, making a total amount paid of \$73,670.10. The average age of the full membership to date is 36 $\frac{30}{100}$  years; an increase since last year of  $\frac{63}{100}$  of a year; but a decrease of  $\frac{65}{100}$  years from 1880. During the last session of the New York Legislature, the Union of Mutual Benefit Associations of the State of New York, of which the League is a member, had a bill presented for the protection of mutual benefit societies which became a law in April. At the suggestion of your President, your Executive Committee had filed with the Secretary of State an application for re-incorporation under the new law, and you became re-incorporated on Oct. 16, 1883. In order to assure the members that their assessments shall not exceed a certain amount during any one year, your Executive Committee are unanimously in favor of establishing an Elastic Fund, which shall be used only to pay death losses when the deaths number over a certain percentage during the year. \* \* \* A communication from your President was received Dec. 29, stating that he held, as trustee, \$4,441.03, the net proceeds of the Chicago Fire Fund litigation, together with three several gifts in that connection, amounting in all to \$4,938.53. During the year your Committee has had presented to them 81 requests for change of beneficiary which were granted; and your Secretary has been notified of 1,500 changes of address which were made on the books of the League. In the month of February the League was made his beneficiary by Isaac M. Miller, who generously transferred the benefit to come at his death to the President of the League, in trust for the Permanent Fund. The Executive Committee desires to make acknowledgment of the gift of fifty dollars from the New York Jewelers' Club. The amount was to be used as a "help fund" to aid needy members of the League to pay their assessments. It was deemed preferable that the Club should retain the amount and permit the League to co-operate in its distribution. Therefore, the amount was returned, but the spirit of good will and fellowship that actuated the gift is none the less appreciated. The following proposed amendments to the Constitution were filed with the Secretary, as provided by the Constitution and By-Laws, providing for an additional section of membership with a limited benefit of \$1,000, etc.; also, to provide a Contingent Fund to relieve members from excessive assessments; also another amendment for the same purpose; also to provide for voting by proxy at the annual meetings."

The report was signed by Gilbert T. Woglom, James P. Snow, Henry Hayes, W. C. Kimball, Aug. Kurtzeborn, J. B. Bowden, J. D. Yerrington, Robert A. Johnson, Sam. W. Saxton, C. B. Bishop, John D. Lyon, Chairman.

The report was accepted and placed on file.

The meeting then listened to the report of the Trustees of the Chicago Fire Fund. Mr. Woglom, in making the report, stated that he had the pleasure of presenting to the Treasurer of the Jewelers' League the sum of \$4,441.93, being the net proceeds of the Chicago Fire Fund after deducting all the expenses, which amount was to be delivered into the treasury of the Jewelers' League. Mr. Woglom in the course of his remarks said: "A word of thanks is due from us, I am quite sure, to these gentlemen who have so generously given us their share in the Chicago Fire Fund. It has been given twice for a charitable purpose; and further, I have the pleasure of presenting on behalf of Messrs. Randel, Baremore & Billings, the net amount which they secured out of their share of the Chicago Fire Fund. This amount is \$205.25, which I have the pleasure of presenting to the Treasurer of our League. [Applause]. At the close of the suit it was determined that the Trustees were entitled to some commission for their care of the fund during the previous ten years. That care has been good and I am quite sure they were entitled to all the commission they got. Those gentlemen have donated to the same fund of the Jewelers' League, each one of them,

his share of commission which was awarded them by the court. I have the pleasure of presenting to the Treasurer the amount donated by Enos Richardson, amounting to \$146.12, and the amount donated by Henry Randel, his co-trustee, for \$146.13."

After Mr. Woglom sat down, Secretary Sexton moved that the amount be accepted from him and transferred to the treasury of the Jewelers' League, to be added to their permanent fund. The motion was carried.

It was then moved and carried that the thanks of the League be tendered to the President, Mr. Woglom, for his care and attention in the management of the Chicago Fire Fund trust; and a resolution was adopted that a committee of three be appointed to draft resolutions of thanks to all the gentlemen who have given their donations in the matter of the Chicago Fire Fund to the Jewelers' League.

A resolution was then offered by Mr. Lyon to the effect that there should be a nominating committee of five persons, three of whom should be elected at that meeting for the term of one year, and two of whom shall be appointed by the President from the members of the Executive Committee for the current year at least sixty days before the annual meeting; the purpose of this committee being to decide on the names of the nominees for the several offices becoming vacant at the annual meetings, the names to be submitted to the Secretary to be forwarded by him to all the members with the call for the annual meeting.

The motion was very thoroughly debated.

Mr. Ellison thought it took the power from the members and placed it in the hands of a close corporation.

Mr. Hayes thought the resolution should receive full consideration.

Mr. Kimball believed it would give the members time to mature their opinion on the merits of the various candidates for office, so they could elect a good man and defeat a bad one. Several other gentlemen took part in the discussion.

Before the question was put, Mr. Menaldi offered an amendment that the two members from the Executive Committee be appointed on the same evening that the other three were elected. The amendment was accepted.

The resolution, as amended, was then voted on and rejected by a vote of 113 to 81.

The President requested Mr. Henry Hayes, second Vice-President, to take the chair and proceeded to present to the meeting a series of amendments to the Constitution, recommended by the Committee of Eighteen. The purport of the amendments was the formation of a new class in the League with a death benefit of \$1,000, for such members of the trade as do not desire so much as a \$5,000 benefit; this new class should be termed Section B., and the section composed of the present membership should be termed Section A. The limit of age at entrance should be from 21 to 55 years, and the assessments levied should be gradually increased as members grow older; a member at the age of 21 being assessed \$1.70, and at the age of 60, \$5.60. After 60 years is reached the assessment should not increase but gradually diminish, being adjusted according to the American Experience Table of Mortality.

During the course of Mr. Woglom's remarks he urged that the arguments favoring a Contingent Fund for Section B. would be just as cogent as if presented later in the evening with reference to the present membership of the League.

After some discussion the above was voted on and lost.

Mr. Kimball next took the floor and proposed several amendments to the Constitution relative to the creation of a Contingent Fund. He urged very strongly their adoption, and explained in a very clear manner how this fund could be accumulated. He said: "At the present time, with a membership of 3,000, after each assessment we receive \$6,000, and \$5,000 is paid to the beneficiary, and \$300 of it goes to the Secretary and Treasurer for his services, which leaves a balance on hand of \$700, and that \$700 we propose to put into a fund to be known as a Contingent Fund. This then is to be

under the care of the Executive Committee who can act as trustees, and it is to be invested in Government bonds. Whenever the death in the League shall exceed  $1\frac{1}{4}$  per cent. of the membership, then this fund is to be called upon to pay a death loss. With the membership that we have now,  $1\frac{1}{4}$  per cent. is  $37\frac{1}{2}$ , which would make an assessment of \$75; so that whenever any one year you are called upon to pay \$75 and there should be another death, the other beneficiaries will be paid from the fund." He also proposed to add to this fund whatever amount in excess of \$2,000 might accumulate in the general fund. He urged that it was the opinion of those who had given this matter much thought that it was deemed advisable for the longevity of the institution that it should have a Contingent Fund. He concluded his remarks by saying that to judge from the past year there was not much danger of accumulating this fund too fast; but even if this fund was found to be growing too rapidly, the plans for its accumulation could easily be modified at any annual meeting. Mr. Kimball then moved the adoption of the first of the proposed amendments to the Constitution, as follows:

ARTICLE VI.—Section 1.—Strike out all after "like manner" and substitute:

"Whenever the amount in the special deposit exceeds the sum of five thousand dollars, the excess shall be transmitted to the contingent," which will then read as follows:

#### ARTICLE VI.—PAYMENTS.

Section 1.—The amount arising from the payment, by each admitted member, of two dollars for first assessment, together with the assessment ordered by the Executive Committee of two dollars upon each other member, shall be placed in a Trust Company as a special deposit. Upon satisfactory proof of the death of any member of the League, the Committee shall pay this amount so collected (less five per cent.), not exceeding five thousand dollars, to the person or persons, whose names shall, at the time of the death of such member, be found recorded as his last designated beneficiaries, or in case of their death, to their legal representatives, and the receipt of the proper party in either case shall be conclusive and final, except when such member shall have, in his last will and testament, left the amount to other parties than the ones designated on the books of the League, and legal notice of the probate of such will shall have been served upon the Secretary of the League before the payment of the loss shall have been made. Immediately after having ordered the payment of a death loss, the Executive Committee shall order another assessment of two dollars upon each member, to be used in like manner. Whenever the amount in this special deposit exceeds the sum of five thousand dollars, the excess shall be transferred to the Contingent Fund.

Mr. Marks thought the resolution as presented very wise and judicious.

Robert A. Johnson was in favor of the amendment, and delivered an effective speech in its favor, which was received by the meeting with applause. Mr. Johnson said: "Mr. Chairman and gentlemen, you will bear me witness that during all these years that I have been an officer of the League, I have very seldom occupied your time at these annual meetings, and this for two reasons: The first is that I do so much talking for you during the year, that I think you should do the most of it on these occasions; the second, and perhaps the best, reason is that when I face an audience as large and respectable as this, I get frightened and forget half I would say. It is only because I feel how absolutely necessary this contingent fund is or will be in the future, that I am bold enough to ask for a few moments of your time. We are a firm or corporation doing a very large business on a very small capital. Our losses have been unusually small, and the firm is perfectly solvent at this time, but this state of things *will not, cannot* last. This is probably the last year that any of us will have \$5,000 of insurance at a cost of \$8.00. The death rate will be larger, very much larger; and in case of epidemic or accident, how many are there of us who would have the ability, even if they had the disposition, to meet the heavy extra assessments that would be necessary. On the 6th of last July, the steamer Stonington carried as passengers from New York to Providence 150 members of the Jewelers' Club of New York, over fifty

of us were members of this Jewelers' League. An hour or two before leaving, two or three of us who are present this evening were speaking of the possibility of an accident, and wondering if twenty out of the fifty of us were lost, what amount of insurance our beneficiaries would receive. We did not arrive at any satisfactory decision, so we did the next best thing, we hedged, and took out accident policies for forty-eight hours. Every steamer that leaves Providence for New York, or New York for Providence, carries as passengers a large number of our members. I sincerely trust that they may all journey safely; but if an accident should occur, or if an epidemic should make its appearance in any part of our country, then this contingent fund would not only be a necessity, it would be the very life of the League. Accumulate it as you please, look it up as you please, make as its custodians just whom you please, but start the fund to-night. I speak earnestly, and I feel just as I speak. I am the second member of the League; through your kindness I have been one of its officers ever since its organization. With such ability as I have, in connection with my associates, I have labored faithfully and carefully to advance its interests, and with your coöperation we have made it what it is. This sapling that we planted seven years ago has grown into a tree whose proportions are as astounding as they are magnificent. Let us see to it that no sudden calamity shall drag its roots from the earth. Then, as long as we live, under its wide-spreading branches shall we have comfort and absolute security."

Mr. Lyon also spoke in favor of the amendment.

The motion was then put to a vote, and the amendment was almost unanimously adopted as part of the Constitution.

Mr. Kimball then arose and said: "We have crossed the bridge, and I am very much obliged to you for your vote. Now we have some other amendments to offer to carry out the provisions. The next amendment which I would make to your Constitution is that the money which is in the general fund, in excess of two thousand dollars, be passed to this contingent fund. The following is the amendment which was unanimously carried:

ARTICLE VI.—Section 3.—Strike out all of that part of Section 3, Article VI. after the words "shall exceed," and substitute "the sum of two thousand dollars, the excess thereof shall be placed in the Contingent Fund." The section as amended will then read:

Section 3.—Whenever the amount in the Treasury of the Jewelers' League of the City of New York, which may accrue in any manner, exclusive of the special deposits provided for in Section 1, provided for in this Article, shall exceed the sum of two thousand, the excess thereof shall be placed in the Contingent Fund.

On Mr. Kimball's motion, Article 12 was changed to Article 13,

Mr. Kimball then moved, and it was carried, that a new Article be made to be known as

"ARTICLE XII.—CONTINGENT FUND," as follows:

Section 1.—There shall be accumulated in the manner hereinafter provided, a fund to be known as the Contingent Fund, the object of which shall be to furnish means for the payment of extraordinary losses caused by disaster, epidemic or otherwise, which might inordinately increase death assessments during any one year, and thereby render many of our members unable to retain their membership.

Section 2.—The Executive Committee of this League, in addition to the powers and duties heretofore conferred and imposed upon them, shall be the Trustees of said Contingent Fund.

Section 3.—Within sixty days after the adoption of this Article, the Treasurer of this League shall pay over to the Trustees of the Contingent Fund all moneys in his hands in excess of the sum of five thousand dollars in special death loss fund, and two thousand in general fund. This fund shall be increased by adding all surplus moneys that may accrue after paying losses and Treasurer's commissions upon the collection of death assessments.

Section 4.—The Trustees aforesaid shall deposit all moneys received under this Article in an incorporated bank or trust company to the credit of the League, and whenever these deposits with their accretions of interest shall amount to a sum sufficient to purchase a bond of the United States Government of the denomination of \$1,000, and of an issue approved by the said Trustees, the same shall be invested

by said Trustees in such bond, which shall be registered in the name of the League and deposited in some depository approved by the said Trustees. Such moneys as securities to be withdrawn from the said Bank or Trust Company depository in the same manner as moneys from the special assessment fund are, or may be, authorized to be drawn.

Section 5.—Whenever in any one year the assessments for deaths in the League exceed  $1\frac{1}{4}$  per cent. of the membership, the Trustees shall apply so much of such Contingent Fund, as in their judgment may be to the best interests of the League, to the payment of the benefits to the beneficiaries of the members whose deaths shall thereafter occur within said fiscal year, in lieu of an assessment upon the surviving members therefor. A record of such action shall be kept in the Executive Committee minutes.

A proposition to amend the Constitution, which had been presented by Mr. Hirsch, of Chicago, was thereupon called up, and, after discussion, was rejected by a very strong vote.

The next business in order was the election of officers.

Mr. Gilbert T. Woglom was unanimously re-elected President of the League.

Mr. James P. Snow and Mr. Henry Hayes were elected Third and Fourth Vice-Presidents, and Mr. William L. Sexton was unanimously chosen Secretary and Treasurer for another year.

The following gentlemen were elected members of the Executive Committee: J. B. Bowden, George R. Howe, and C. G. Lewis.

The President appointed Thomas W. Manchester, A. A. Jeannot, David Untermeyer, Examining Finance Committee for the year. He also appointed Messrs. Otto Somrenschein, Benjamin Allen and S. H. Hall the Special Committee to draft resolutions in regard to the Chicago Fire Fund.

On motion the meeting adjourned.

## The Jewelers' League.

President, GILBERT T. WOGLOM.....Of Woglom & Miller.  
First Vice-President, JAMES P. SNOW.....Of G. & S. Owen & Co.  
Second Vice-President, HENRY HAYES.....Of Wheeler, Parsons & Hayes.  
Third Vice-President, WM. C. KIMBALL.....Of H. F. Barrows & Co.  
Fourth Vice-President, AUG. KURTZEBORN..Of L. Bauman Jewelry Co. St. Louis, Mo.  
Secretary and Treasurer, WILLIAM L. SEXTON.....Of Sexton & Cole.

### EXECUTIVE COMMITTEE.

JOHN D. LYON, Chairman.....Of Lyon & Hardy.  
JOSEPH B. BOWDEN.....Of J. B. Bowden & Co.  
JAMES D. YERRINGTON.....Of J. D. Yerrington & Co.  
ROBERT A. JOHNSON.....Of Colby & Johnson.  
SAMUEL W. SAXTON.....Of Saxton, Smith & Co.  
CLEMENT B. BISHOP.....Of Carrow, Bishop & Co.

### EXAMINING FINANCE COMMITTEE.

CHARLES G. LEWIS.....Of Randel, Baremore & Billings.  
CHAS. G. ALFORD.....Of C. G. Alford & Co.  
GEORGE R. HOWE.....Of Carter, Sloan & Co.

THE JEWELERS' CIRCULAR is the *exclusive* official paper of the Jewelers' League, and has been selected for the publication of all matters of interest pertaining thereto. Letters or inquiries pertinent to its business or purposes, and which might interest the trade or inquirers, will herein be answered. Address *Jewelers' League, Box 3,444, P. O., New York*, or the office of THE CIRCULAR.

At the regular meeting of the Executive Committee, held Jan. 4, 1884, the following 47 applicants were admitted to membership:

F. P. Benedict, W. A. Boardman, A. Cohn, F. F. Gibson, L. Zoellner, N. Y. City, N. Y.; A. Weidman, Jr., Syracuse, N. Y.; C. F. Baldwin, Cortland, N. Y.; W. W. Detrick, H. W. Freund, W. Roulet, Chicago, Ill.; A. Conrady, Centralia, Ill.; L. Zuefle, E. Herbrich, J. Lowenhardt, Cincinnati, Ohio; W. Walcott, Toledo, Ohio; W. Mason, V. H. Lavigne, Philadelphia, Pa.; W. Schopperle, Bradford, Pa.; J. H. Thornhill, Wilkesbarre, Pa.; G. Beogenshausen, Z. Fehrenbach, A. J. Hilsbury, T. Letzler, Louisville, Ky.; W. H. Coburn, Newport, Ky.; L. Oberdorfer, Henderson, Ky.; S. M.

Snider, J. T. Clark, Greenville, S. C.; J. E. Evard, B. G. Ruhl, Galveston, Texas; F. P. Fowle, Newark, N. J.; J. M. Lewis, Lambertville, N. J.; R. H. Boullemet, New Orleans, La.; A. H. D. Bening, Salem, Va.; O. H. St. John, Milford, Mich.; G. Bliss, Ann Arbor, Mich.; J. Brandstetter, Grand Haven, Mich.; J. S. Shean, Mt. Pleasant, Iowa; R. N. Blair, Dunlap, Iowa; Chas. A. Patterson, Great Bend, Kan.; B. B. Pollock, Leavenworth, Kan.; J. D. Reynolds, Baltimore, Md.; P. A. Nolting, St. Louis, Mo.; J. W. Rivers, Boston, Mass.; G. R. Plummer, Providence, R. I.; G. W. Thompson, Newport, R. I.; H. B. Jolley, Winnipeg, Manitoba, Can.; J. S. Barnard, Whitby, Can.

At a special meeting of the Executive Committee, held Jan. 10, 1884, the following 12 applicants were admitted to membership:

A. Klass, A. E. Lebkuecher, E. S. Watkins, N. Y. City, N. Y.; A. F. Rigoulot, Brooklyn, N. Y.; J. G. Quick, Rochester, N. Y.; J. M. Seifert, Rockford, Ill.; L. B. Coe, Springfield, Mass.; E. S. Clark, Waltham, Mass.; W. E. Crellin, Chillicothe, Mo.; W. H. Cook, Toledo, Ohio; C. S. Dovey, Philadelphia, Pa.; J. Buck, Memphis, Tenn.

### Sight.

#### WHAT THE OPTICIAN SHOULD KNOW ABOUT OPTICS.

Based upon an extensive hospital experience in Austria, Germany, England and New York. By C. A. BUCKLIN, M. D., New York. Author of Detection and Correction of Visual Imperfections, Cause and Cure of Cross Eyes, Effects of Color on Distance, and Monograph on Astigmatism.

*Continued from page 390.*

At the beginning of the year it is a satisfaction to review the progress of the past and contemplate the progress of the future.

I can clearly see that the past three years has been a period of great progress among the opticians of America as a class.

The first step which started the ball rolling was the publication and circulation of the little work known as "The Detection and Correction of Visual Imperfections."

The second and most effective step has been the Articles in THE CIRCULAR entitled "What the Optician should know about Optics."

The third great step commencing the year 1884 will be the introduction of an optical instrument which will detect and correct all visual defects with automatic exactness.

Since THE CIRCULAR commenced to publish articles on "What the Optician should know about Optics" there appears to be a constantly growing interest in this subject; I receive letters continually from the opticians throughout the United States, of a private nature, asking for information and advice as to books and appliances necessary to correct visual defects properly. Douder's work on "The Refraction and Accommodation of the Eye," is the greatest work in the English language. It is technical, mathematical and in no way adapted to the wants of the Optician. It goes deeper into this subject than any other work in the English language. The completest work in the world on this subject is "Optische Fehler des Auges," by Ludwig Manthner. This work is completeness itself, but it is even more technical and mathematical than Douder's work, and I do not believe that there are twelve specialists in the world who ever read this work carefully through. It appears to be a little too heavy for them.

Having carefully studied every work of a practical nature, in either the German or English language, I considered some two years ago to publish a little work upon theoretical optics as applied to the correction of visual defects. This little work, entitled "Detection and Correction of Visual Defects," has everything in it necessary to know about optics as a theory, that one may, with intelligence, correct visual defects. And there is nothing in the book that an intelligent optician should not know.

Many have carefully read and thought over the articles in THE CIRCULAR and have already become very intelligent upon this subject.

I am however occasionally pained to hear an optician ask some explanation of the new or metric system of numbering lenses, when it has been so carefully described in THE CIRCULAR, and also in my little work, both of which he probably has in his store. If you wish to know anything about "Optics" you will find every thing you want in this little book, or in the back numbers of THE CIRCULAR. Each chapter on this subject should be carefully read, thought over, and re-read *several* times. It is the only book I can commend to a beginner who wishes to obtain quickly, a *theoretical* knowledge of optics, as applied to vision.

Having mastered this, if you wish to go further, buy Douder's work, or better, if you read German, buy Manthner's book.

Some have raised objections to the above mentioned little work because it was published by a manufacturing optical firm, without having carefully examined into the merit of the book, they pronounce it a species of "advertisement."

I wish the readers of THE CIRCULAR, to understand thoroughly just how it happened that an optical firm published this work. I was a stranger in the city, just having arrived from Vienna. I attempted for the use of family physicians and opticians to make the theory and nature of visual defects simple, and rob the subject of its head-splitting mathematics and technicalities, I took the manuscript to Wm. Wood & Co., the leading medical publishers; they did not want to look at it. They had something better, written by a NOTED oculist. They were even kind enough to go to those who became the publishers of this little work, and advise them not to have anything to do with the publication of the manuscript, as it would have a poor chance to compete with their "Visual Tests," carefully prepared by a noted oculist.

In the face of this advice, The Spencer Optical Manufacturing Co. took this manuscript, and after twelve hours, consideration, decided to invest eight hundred dollars in this attempt to popularize the theory of visual defects among American Opticians. They were the only parties I could find who had the courage to decide on its merit and back it with their money.

The fact that the name of this firm appearing in THE CIRCULAR in connection with this book, has caused some criticism from those who have made no attempt to examine into its merits. My answer to this criticism is, they advanced the necessary money to publish a book adapted to the wants of opticians, without any assurance that they would ever get their money back, and they naturally attached their name to it.

Wm. Wood & Co. left all the money they invested in their venture, but I am proud to say that "The Detection and Correction of Visual Imperfections" took care of its own finances.

The *Second* and the *greatest* step ever taken to awaken the opticians of the country to a realizing sense of the importance of more thoroughly understanding the theory of visual defects, is the series of articles upon "What the Optician should know about Optics," proposed and most liberally paid for by Mr. Hopkinson.

Some of our readers will be a little surprised to hear that a long article on optics, presented to Mr. Hopkinson one morning by his translator, which was translated from a German journal published in Leipzig, was found to be an indifferent translation from one of our articles on "What the Optician should know about Optics," published in a previous number. It is a general verdict among optical dealers that there has been a great improvement in the intelligence with which the average optician orders such goods as he desires.

The constantly increasing intelligence, as displayed by the letters of enquiry regarding obscure visual defects, about which I am sure the average optician knew nothing two years ago, is also positive proof that a large number of opticians have become earnest thinkers.

The Opticians have become progressive, having learned about astigmatism and its various combinations with other visual defects, they are urgently demanding some optical device which will enable will enable them to correct the defect when they discover it.

The opticians now desire some device by which they can *measure*

ALL visual defects rapidly and correctly. As yet there is no instrument that fully meets all the requirements, which are as follows: It must be *cheap*; must do the required work *rapidly* and *accurately*, and must be so simple that it cannot get out of order. It must, in addition to this, be so ornamental that it is the pride of every store or office that has it.

Two hundred dollars were required to produce an experimental instrument that fulfilled all the scientific requirements.

Two thousand dollars were required to put the instrument on a basis so that it could be manufactured cheaply.

It will correct every visual defect that can be corrected or that is not complicated with disease. They do the work correctly and very rapidly. The instrument figures its own combinations, or in other words, the entire prescription for the lens, be it ever so complicated, is automatically indicated, so that you only have to follow simple instructions, and copy your order for the lens from the face of the instrument. The distance between the pupils, which is always so important to state, is also automatically indicated; when the proper pupillary distance has been measured the person sees double, and he can only see double when it is measured correctly. As The Spencer Optical Manufacturing Company have kindly risked twenty two hundred dollars to bring out a perfect instrument costing only thirty dollars, for the use of opticians and physicians, the instrument has received the name of "*Spencer's Ophthalmoscopic Test Lenses*."

#### DESCRIPTION OF THE INSTRUMENT.

It consists of a hollow cylindrical frame, one foot in diameter a hollow hub projects from the center of both heads of the cylinder, forming on one side an eye piece, and on the other side a simple hub. The eye piece and the hub form a hollow axis upon which the cylindrical frame revolves, being supported by a flat pyramidal arm passing in front and behind the cylinder, the bearing upon which it rotates being situated in the apex of these arms. Within this cylindrical frame there are three disks, two of them having thirty half inch perforations at equal distances from the center of the disk, and at equal distances from each other. The third disk has only twenty-seven perforations in its margin, each disk revolves on a separate axis, the perforations in the margin of each disk turns exactly opposite the opening through the hollow axis which supports the main frame. Twenty nine of the openings in the right hand disk contain simple convex lenses with blank opening indicated as o. The margin of this disk just projects beyond the main cylindrical frame sufficiently to enable you to rotate it, as you rotate it from above down, beginning with o you will bring before the central opening in rotation all the convex lenses from sixty to five, indicated by the sign +. The left hand disk rotates from above downward and has the same number of concave lenses indicated by the sign —. The upper disk contains, commencing with o, thirteen convex cylindrical lenses if you turn toward the right, or commencing at o thirteen concave cylindrical lenses. If you turn toward the left each concave cylindrical lens has the sign — written under it, and each convex cylindrical lens has the sign + written under it. The face of the cylindrical frame containing the disks is ornamental, being finished in nickel and black. There are openings in the face for each disk; the numbers found in these openings indicate the nature and strength of the lens or lenses, which are opposite the central opening. At the lower margin of the disk is a double scale, one scale indicates the axis of the concave, and the other the axis of the convex cylindrical lenses. When the instrument is in its normal position the axis of all the convex cylindrical lenses are 90°, while the axis of all the concave cylindrical lenses stand at 180°, this being the position in which the eye usually requires these lenses. You need not however give the matter of the axis of these lenses the slightest thought, as you simply have to copy your prescription for lenses and the degrees of the axis as it is automatically indicated on the face of the instrument. The outer row of numbers on the scale indicate the axis of the *concave cylinders*; the inner row the axis of convex cylinder.

The following cut shows the instrument with a stand adapted for a table or stand. I advise strongly to use the instrument on a table and to place the patient in an easy sitting position with his face *square* before the instrument. Any attempt to impress on your patrons that you are anxious to have everything as it should be will be

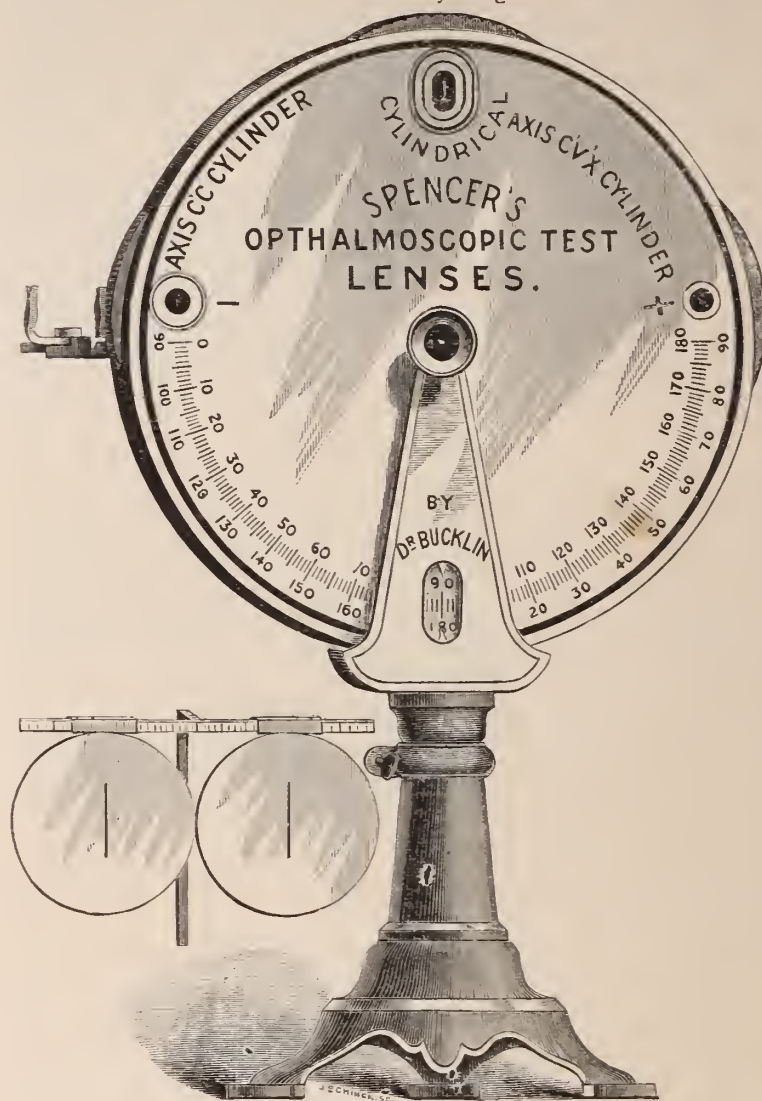

well rewarded. If desired, a foot which rests on the floor may be had in place of the table foot. The instrument is not as attractive to the eye with this floor foot. With this instrument you can *rapidly* correct any optical defect, *Hyperopia*, *Myopia*, *Presbyopia*, *Astigmatism* or *Astigmatism* combined with any of the other optical defects.

As compound cylindrical lenses with axis crossing are so *very* expensive I avoid using them. You can invariably get along by correcting the defect as well as possible with a spherical lens, then correct the remaining faulty meridian by combining a cylindrical lens with it. The instrument is ornamental and attractive. You test each eye separately, and then measure the distance between the pupils by my new automatic measure. To avoid confusion, this instrument and its uses will not be described till we have finished the correction of simple or *monocular* visual defects. The failure to have the pupillary distance correctly measured will make the best adjusted lenses uncomfortable.

#### HOW TO CORRECT OPTICAL DEFECTS.

If you wish to establish a reputation as a thorough optician, you should have a systematic manner of arriving at your conclusion. You should keep a small register in which to record important facts, such as the age of the patient, acuteness of vision of each eye, amount of improvement brought about by the use of glasses, and if you notice anything peculiar about the case or the complaint of the patient make a note of it. You may find it of value some future time. It is common sense to get as much information as you can from the use of your own eyes and ears before you begin to resort to

experiments to find out something without knowing what you wish to discover. The first hint, as the patient comes under your observation, is gained frequently from his age. If he has on glasses as he comes in, it is no time lost to notice what glasses he is wearing. How long he has worn them. Ask what he complains of now. When did he first notice the defect he now complains of? You must have hanging in your store a standard test for distant vision, which should be ten, fifteen, or better, twenty feet from the person to be examined; an astigmatic fan, although not absolutely necessary, will frequently save much time. The rows of letters are marked: CC. C. LXX. L. XL. XXX. XX. XV. X. If the letters are ten feet away and the last line can be read, the vision is normal,  $\frac{10}{10}$ ; if he could only read the xv line the vision is not normal, it is  $\frac{10}{15}$ . The number of feet the letters are away gives the numerator, and the number of the finest row of letters which can be read, gives the denominator of a fraction which expresses the acuteness of distant vision. Testing the acuteness of vision is the first thing to be done if you wish to escape vexing blunders.

I.—If the person is over *forty*, complains of difficulty in reading, and the acuteness of vision is normal in each eye, every optical defect except presbyopia is excluded. Direct him to look through the instrument at a card eleven inches distant and turn on the *weakest* convex lens with which he can read the fine print on the card with perfect ease, test each eye, measure the pupil distance, and if there is any difference in the lenses you will usually find it best to give the weakest lens to both eyes, although, in some cases, they bear different spherical lenses before each eye. To complete this examination it takes only a few seconds. In testing distant vision, remove the card and use the distant letters.

II.—If person is under *forty*, acuteness of distant vision is normal, and they complain of weak vision, slow symptoms of becoming cross-eyed, you should turn on the strongest convex lens through which it is still possible for them to retain normal distant vision. In all cases where the acuteness of distant vision is normal, give to the young who have weak eyes the strongest convex lenses through which they still retain distinct distant vision, and to the old the *weakest* convex glasses through which they can see to read fine print on the card at eleven inches. All cases which come under the two classes above mentioned, where distant glasses are required, give the strongest convex lenses through which the distant vision is still distinct. Distant glasses, where the acuteness of distant vision is normal, are only required by those who begin to look cross-eyed or become tired without attempting to read. In young people, the distant glasses are adapted for reading purposes. You seldom find a person over *forty* who has normal acuteness of vision, who requires glasses for the distance. Should you meet such a case, give the strongest convex glass through which the distant vision is not made less distinct. The reading glasses in such a case will be stronger than the glasses for the distance. The strength of the required lens can only be told by practically testing with fine print at eleven inches.

#### WHEN THE ACUTENESS OF DISTANT VISION IS NOT NORMAL.

You have in these cases to decide between *hyperopia*, (natural or acquired) *Myopia*, *Astigmatism*, *Cataract*, *all diseases of the Cornea*, *all intra ocular diseases* and all intra cranial diseases.

I.—If near vision is *perfectly* satisfactory in both eyes, you know that you have simple myopia, which will only require concave glasses for the distance. Direct the person to look through the instrument and turn on the concave lenses till the best possible vision has been obtained; if concave lenses bring the acuteness of vision up to normal, myopia is the only trouble. Give the weakest possible concave lenses through which this distinctness of vision can be maintained. Where the degree of myopia is very high, the near vision will not be satisfactory; they will hold their work very near and you will find trouble in prescribing lenses which make distant vision normal, and if you find that very strong lenses make the distant vision normal, when you put them on they make objects disagreeably small, or give a *disagreeable, sickening, swinging* motion to observed objects. In these

cases you must give the weakest concave lenses which give comfortable and sufficient distant vision for all practical purposes and not attempt to bring the acuteness of distant vision up to any given standard. These cases of excessive myopia are the most troublesome of all we have to deal with, and frequently you cannot do anything with them. *Some cases* of myopia require lenses to enable them to see near work or read at the required distance; in this case, give the weakest concave lenses which will enable them to see required objects at the required distance. *Some persons* who are slightly myopic as they advance in age, require convex lenses for reading. In such cases, the presbyopia becomes greater than the myopia. They however still require concave lenses for the distance.

#### SIMPLE DIRECTIONS FOR USING THE OPHTHALMOSCOPIC TEST LENSES.

*Keep both eyes open and face square before the instrument.* If distant vision is not normal, glasses for the distance are adapted as follows: Seat the person with the face *perfectly square* before the instrument. As the person looks through the instrument, turn on the + (convex) lenses commencing with +60; if they make distant vision less distinct, *Hyperopia* is no element in the case; if they improve vision, turn on the strongest convex lens that does not make vision indistinct; if the convex lens bring the acuteness of vision to the normal standard, hyperopia is the only trouble, and the lens will be the one required for reading and distance in young persons, and will be the lens required for distance by persons beyond *forty*. The lens for reading will be found in this case by directing the attention to the card on the arm at eleven inches distance; turn on the *weakest* convex lens which makes this fine print *perfectly* distinct and this will be the reading lens for the eye tested. If convex lenses improve the distant vision to a measurable degree but do not produce distinct vision, allow the best + (convex) lens to remain standing and begin to turn on convex cylindrical lenses, rotating the axis of each to the right and left by revolving the entire frame.

After trying each lens, turn the instrument back to 90° its normal position, before trying a second lens. If convex cylinders instantly make vision less distinct, you can abandon their use and try concave cylinders. *Occasionally* a concave cylindrical lens combines with a convex spherical lens. If a convex spherical lens has improved vision considerable, say +20, but vision is not distinct, and we find a convex cylindrical lens, say +30c., added to it with its axis 90°, you would write the prescription for this eye +20=+30c. axis 90°, or if +20 was the best spherical lens, and -24 cylindrical, with the axis 180°, you would write the prescription +20=-30c. axis 180°. The figure one is frequently placed over the number of each lens; this gives a fraction which indicates the refractive index of each lens; thus in the first example it would be  $+\frac{1}{20} = +\frac{1}{30}c.$  axis 90° or  $+\frac{1}{20} = -\frac{1}{30}$  axis 180°. You then test the other eye; give the distance between the pupils and the kind of a frame wanted, and the order for the lenses is complete. Cylindrical lenses will usually give better satisfaction in spectacle or riding bow frames.

When convex lenses do not improve vision, you turn to concave lenses; if they bring the vision up to the normal standard, you have simple myopia, and correct it as before described. Where there is a slight difference between the two eyes, you may in many instances give each eye a different correction. Lenses of this kind are frequently not as satisfactory as those which have the same lens before each eye; on this point you will have to use a little common sense and your own judgment.

When the concave lenses improve distant vision but do not make it clear, you may leave the concave lens standing, which gives the most distinct distant vision, and turn on the concave and convex cylindrical lenses, rotating the axis of each lens backward and forward till you have convinced yourself that the addition of cylindrical lenses do or do not improve vision. When you find the position where a cylindrical lens brings the most distinct vision, you will find its axis indicated automatically, and you simply have to read it off as indicated.

When neither concave or convex lenses improve distant vision,

there is no correctible degree of myopia or hyperopia present. The acuteness of distant vision not being normal, you should begin to try convex cylindrical lenses; if they do improve vision, select the lens for each eye, which makes distant vision most distinct, and note its axis before commencing to test the other eye; if they do not improve distant vision, the trouble is not due to any correctible optical defect.

Where the *acuteness* of distant vision is perfectly normal, you never need look for astigmatism; if it is not normal, one glance at the astigmatic fan will usually settle the question as to the existence of astigmatism. If the lines all look equally dark, there is a poor chance of your finding any astigmatism to correct. If they do not look equally dark, there is probably astigmatism, simple, or combined with some other visual defect. If the line which looks the darkest runs in a vertical direction, or nearly so, you will probably require a concave cylindrical glass, with its axis at right angles to this black line, to correct the astigmatic defect. If the dark line runs in a horizontal direction, or nearly so, you will probably require a convex cylindrical lens, with the axis at right angles to the dark line. Although there are frequent exceptions to this, the above is the general rule.

You have now learned the detailed method of correcting visual defects, and how to determine when there are none to correct.

There are persons who suffer from weak vision, who have no optical defects to correct, and others who have optical defects, the correction of which do not relieve the weak vision. There are also *many* cases that while they are very well with one eye, complain that the other eye is of little or no use to them. The first class of cases may have a disturbance in the equilibrium of the various sets of muscles, which give to the eye its mobility. The second class frequently have lost, or never had, *bi-nocular* vision; most of these persons have, or have had, a cast in their eye. The cast may be so small as not to be noticed, but the vision is usually very poor in such an eye, and although it is possible for it to be good, still they will not have bi-nocular vision, that is, they never see objects with both eyes at the same time.

The instrument for the measurements of the distance between the pupils, which is a very important attachment to the *Ophthalmoscopic Test Lenses*, besides measuring the distance between the pupils correctly and quickly, gives instantaneous notice of the existence of a lack of muscular equilibrium, or if vision is bad, and one eye gives you notice that any attempts to improve the vision of the bad eye, will probably be unsuccessful.

#### DESCRIPTION OF THE INSTRUMENT.

It consists of two disks fastened to a bar  $\frac{3}{8}$  of an inch square. The disks are  $\frac{1}{4}$  of an inch thick,  $1\frac{1}{4}$  inches in diameter. Each disk has a fine vertical slit through it. One disk is stationary, while the other slides a scale. Placing the movable disk so far out on the scale that your left eye alone sees the observed object through the slit in the left disk, you gradually slide the other disk inward, stopping the instant the observed object appears double, and you will find the proper distance between the pupils, indicated upon the scale. The observed object is a short vertical line on a white ground, placed at the greatest distance the person can see it distinctly; this distance will vary in different cases, from a few feet to fifteen feet. When these double objects stand directly over each other, muscular equilibrium is present. If the double objects stand some inches from each other, laterally, or if one of them slants in any direction, the muscular equilibrium is not perfect. If the vision is bad in one eye, and you fail to produce double vision after a careful trial with the instrument, you need not spend much time in trying to make such a person see out of this eye; he probably has, or has had, a cast in his eye that has not bi-nocular vision. In such a case it will be urged that the instrument will not measure the pupil distance, but in such a case there is no occasion for having the pupil distance exact, as the person never sees with both eyes at the same time. All cases of muscular trouble should be referred to a good oculist at once, as all other cases should that you do not understand or cannot correct. This attachment gives *The Ophthalmoscopic Test Lenses* most decided advantage over any other instrument of the kind.

If by the experiments we have made you are unable to find out the cause of the bad vision, you have only left as causes, cataract, inflammatory diseases of the eye, and diseases of the brain and optic nerve. Diseases of the optic nerve are quite frequent; the common cause is alcohol, or the excessive use of tobacco; the same amount of tobacco used in a pipe has more effect than when smoked in segars. This class of cases begin to fail very early as a rule in their ability to tell all shades of red and green colors. Generally they retain yellow and blue colors to the last. It always struck me as a foolish thing for railroads and steamers to choose two colors for signals which man is most likely not to recognize should his color sense begin to fail him. I never have been fortunate enough to see a color blind person who could see anything, who could not tell the colors yellow and blue; these colors should be used for signals, and not green and red.

My last advice is, that if you do not find out what the trouble is, insist as strongly as you can that your patron consult some one whom you know to be a thoroughly expert specialist.

All necessary allowance for the distance of the lenses from the eye in this instrument has been made. The scale indicates the axis of the cylindrical lenses according to the standard method now in general use. The *patient* facing the face of the clock, 9 o'clock is  $0^{\circ}$ , 12 o'clock is  $90^{\circ}$ , 3 o'clock is  $180^{\circ}$ —applied to each eye.

#### Views of Correspondents.

This department of *THE CIRCULAR* is open for communications relating to the jewelry trade, but the editor does not hold himself responsible for the sentiments expressed by contributors. We invite correspondence, but require that it shall be free from all personalities, and the writer's integrity guaranteed by the disclosure of his true name to the editor. Anonymous communications will not be noticed.

*To the Editor of the Jewelers' Circular :*

I notice in the December number of *THE CIRCULAR* in the article by "Detent," a solution of the "problem" regarding the fitting of the pallet jewel, which, like many other opinions published in *THE CIRCULAR*, I believe is open to criticism. As such action as he was considering is, in the nature of the case, incapable of mechanical or mathematical demonstration, one can account for the phenomenon, to his own satisfaction, only by the use of his reasoning powers, by reasoning from apparent effect back to *probable* cause. In regard to the pitting of pallets near the corner, I have always considered it to be the result of the tooth *falling short* in a shallow escapement, and I do not think that I ever saw a pit where the escapement was not or had not been too shallow. It is hard to believe that the alertness of the scape wheel tooth would be insufficient to enable it to *follow up* the comparatively slow action of the pallet. I think that nothing much short of lightning would get away from the tooth after the unlocking. And even admitting for the sake of argument that the tooth was so dilatory, how could it possibly attack the yielding pallet—already in motion—with such destructive effect? But on the other theory the sharp concussion and peculiar *digging* action of the tooth in forcing back the pallets and train accounts most naturally for the pitting.

As one of the most important and valuable of the functions of *THE CIRCULAR* is the instruction of the learners of our profession, I think that it would be well if criticisms of articles appearing in its columns were more frequently indulged in by those of us who have opinions of our own. It would tend to the improvement of the journal as well as of its young readers.

I remember that during the publication of the valuable articles by "Excelsior," he gave as a rule of his practice, that the *gold spring* in the chronometer escapement should be of such strength as to offer the same resistance to the return vibration of the balance as did the locking spring in the lifting. I have always made the gold spring as *light* as possible consistent with safety, and with good



results. I would like for some member of the Club to give a good reason for "Excelsior's" rule.

Again, it would be profitable and edifying to your readers, if practical watchmakers would comment in the extensively read columns of THE CIRCULAR upon some of the absurd and unpractical escapements therein illustrated, notably, the "double impulse chronometer," a device which I believe cannot claim a single merit. Such things allowed to pass without comment are calculated to mislead apprentices with the idea that the principles are sound.

While I am writing, I will tell the Club how in half an hour I improvised an *odometric*, or "roadometer," as many people call them, for my buggy, from a chronometer watch which I had long ago converted from an English lever. I removed the balance spring and one of the balance screws, fastened it into a tin movement box bronzed, with the cover turned out for the insertion of a glass, lugs soldered on by which to screw on to the spokes close to the hub of the wheel, which, measuring just  $13\frac{2}{3}$  feet or exactly  $\frac{1}{4}$  of a mile, only needed to have the number of seconds recorded on the dial to be divided by 200 to give miles and decimals. For ordinary use on rough roads I substitute brass bushings for the balance jewels and a light pendulum with stout pivots for the balance, but it can be reconverted to a watch in less than half an hour.

In some future number of THE CIRCULAR I will, if desired, for the benefit of apprentices wishing to make a chronometer escapement, give my process of converting an English lever to a chronometer. There is no way to become master of the principles of the escapement equal to that of making one. If any member of the Club or any reader can say one good word for the "double impulse chronometer" will he please *rise*?

J. H. C.

San Diego, Cal., Dec. 22, 1883.

[Copyright Secured.]

### Letters to Watchmakers.

[By DR. LEONARD WALDO, Astronomer in charge of the Horological Bureau of the Yale College Observatory.]

#### I.

##### OBSERVATORY WATCH TRIALS.

WHEN THE jewelers of a certain New England city had been using the telegraph time signals on their private instruments sufficiently long to have their regular customers stop occasionally to compare their watches with observatory time, several of them spoke with some feeling to the effect that accurate time had destroyed their customers' interest in the watches they had sold to them as being "perfect time pieces." It is so very easy, looking at a highly finished movement which one has to sell, to add the adjectives which express accurate time-keeping qualities, and it is a matter of so much trouble to really find out how accurately watches will run that I suspect very many more watches are sold by the ingenuity of the salesman than by the merit of the watches.

Consider any of the leading American watches, there is no data by which either the producers, the dealers or the buyers can form an accurate estimate as to their merits. The producers are very busy supplying a demand for watches which go "well enough." Except in a few instances their criterion is whether a particular watch sells in large quantities. The dealers care only for watches as articles of merchandise, and the average buyer cares more for external appearance than for intrinsic merit.

This condition of affairs will only last until the production of watches by machinery fully supplies the demand, and until the public is more generally educated as to what constitutes a good watch. This latter education is taking place now at a surprising rate. The production in enormous quantities of very cheap watches and clocks, has immensely extended the use of time, as a result a very much larger number of people are getting information about poor time-pieces, and are discovering that ten dollars a year spent on cheap

timekeepers is a good deal more than seventy-five dollars in ten years on a moderately good one. Then to the very wide use which is made of public clocks and public time signals tells people just how well watches run, and there is an unmistakable and largely increased demand for watches which, in salesman's phraseology, run "within a minute a month," whatever that may mean.

This increased public interest gave rise to the establishment of the department of the Yale College Observatory known as the Horological Bureau. About four years ago we began the work here of telling watchmakers or anybody else just what the running qualities of watches sent to us were. This looks at first like an easy thing to do, but it is far from easy in practice. Let us suppose a first-class movement in a handsome and highly finished case is sent to the observatory for a report or certificate of its performance. You will not be able to find out much about such a movement in less than six weeks, because it must run with its pendent up, right and left, and with its face up and face down in a horizontal position—five positions in all. It must be exposed to such extremes of temperature as it may be expected to receive in actual use. It must be most carefully wound at the same hour every day, and the last turn must be given with exactly the same "feel" or the mainspring will come in to disturb the watch's otherwise good going. It must be compared each day at the same hour with a clock or clocks of the very finest construction, to an accuracy of a single tenth of a second. To insure this latter accuracy it is necessary that the comparison be at the same point of the second's dial each day, and that the method of comparison be automatic and entirely independent of the observer's estimate of the fractions of a second by the face of a watch. I mean that no eye and ear methods by which the observer compares the face of the watch directly with the face of the clock ought to be admitted, but the observer ought simply to tap a telegraph key when the second's hand is exactly over the sixty seconds mark, for instance, of a watch. This telegraph tapping should record itself on one of the large chronographs used in observatories, side by side with the seconds of the standard clock which are recorded at the same time. We have found by actual experiment that the error of such comparisons is about one-twentieth of a second, which of course is far less than the error by any ordinary modes of comparison. During the whole of its trial the greatest care must be taken that the watch is not subjected to any turns, or jerks, or jars, that it is not scratched or finger-marked in the slightest, that in its changes of temperature no moisture is allowed to condense on any part of it, and that in some one position it is allowed to have a long steady run from which its daily variation of rate can be found. The clocks which are to keep the time during the trial must be compared as often as possible with the stars, and the changes of barometer and temperature must be taken into account. The changes in clocks are larger than is commonly supposed; it requires quite a good clock to be sure of watch rates to a second a day, and it not infrequently happens that a fine watch will have its errors so nicely balanced that for a week or so it will rival the finest clock in its performance.

The chief difference between the watch and the clock being the certainty that the watch will vary its rate much more rapidly than the clock. Thus an extremely good watch even might run for a week and on no day of the week be more than a quarter of a second from a perfectly uniform rate. You could expect, however, that its rate would change one or two seconds per day within six weeks. For a clock of the same quality of workmanship to make such a change would be unexpected. The standard clock time by which the watches are compared is often difficult to determine. There comes a succession of cloudy days, the barometer changes quite rapidly and the thermometer also, the clocks are affected by these changes but to just what extent there is no easy means of determining. Something happens to the clock during the long series of observations necessary, or it must be cleaned, or the observer has to leave his work and it passes into the hands of a new observer who has a different way of handling the watches and doing all the work. He means to do

exactly as the first observer did, but in practice it is found that every man's work is different in such delicate operations as rating watches, and consequently every change shows itself in the watch's recorded rate. Then the freedom of operations is quite limited by the fact that everything must be done under lock and key. The hot and cold testing temperature boxes must be inside of steel safes, and the watches must be kept as securely while in them as during any other part of their trial.

The precaution of steel safes is perhaps not necessary, but it is desirable and therefore carried out, because the observatory assumes no risks. The preparation of an accurate report of the performance of such a watch is a labor in itself. There is no way of repeating any part of the watch's performance, and you have no guarantee except the care bestowed at each stage of its rating that the final record is correct. Added to all this the observatory fee for such a report must be made small and out of all proportion to the work entailed.

Watches are produced with very different ends in view, one watch is to represent the finest time-keeping qualities possible, with a very quiet usage and without limitation of price. Another watch is to run well enough for an engineer's usage, when it is subjected to violent usage and must be moderate in price. It is just as important for the observatory to encourage one class of watch as the other. A different programme of trial, therefore, is laid out for different classes of watches. The limitations as to excellence in each class being the same. For convenience four classes are recognized by the observatory at present.

Here is a tabular view of the arrangement of the watch trials in these four classes:

| Test No.             | Position and Temperature. | Class of Certificate. |        |        |        |
|----------------------|---------------------------|-----------------------|--------|--------|--------|
|                      |                           | I.                    | II.    | III.   | IV.    |
| 1                    | Pendant up.....50° to 70° | 7                     | 4      | 4      | 12     |
| 2                    | Pendant to right..... " " | 2                     | 2      | —      |        |
| 3                    | Pendant to left..... " "  | 2                     | 2      | —      | or     |
| 4                    | Dial down..... " "        | 2                     | —      | —      |        |
| 5                    | Dial up..... " "          | 10                    | 4      | 4      | 12     |
| 6                    | " ..... about 90°         | 1                     | 1      | 1      |        |
| 7                    | " ..... 40°               | 1                     | 1      | 1      |        |
| 8                    | " ..... 50° to 70°        | 10                    | 4      | 4      |        |
| 9                    | Pendant up..... " "       | 7                     | 4      | 4      |        |
| Total No. days.....  |                           | 42                    | 22     | 18     | 12     |
| Observatory Fee..... |                           | \$5.00                | \$3.90 | \$2.00 | \$1.00 |

Here is a short extract from the observatory regulations as to the condition in which certificates will be issued:

"No certificate of the classes I., II., III., IV., will be issued in the following cases:

"1. When the variation of rate with the dial vertical and pendant up in classes I., II., III., and in the positions indicated in class IV., exceeds 2°.0 from one day to the following day.

"2. When the variation of rate between the positions of 'Dial up' and 'Dial vertical' exceeds 10°.0.

"3. When the variation for 1° F. exceeds 0°.3 between the ordinary temperature and the oven.

"4. When the rate is greater than 10°.0 per day in any position."

In the first column of the little table given above, "Test No." means that is the number in which the respective positions given in the second column are tried. In the second column, marked "Position and temperature," we have the position named in which the watch is to be tried, and then the approximate temperature. Thus, "Pendant up" means that the watch is hanging and the pendant is highest. Pendant to right means that the watch is hanging, but the pendant is turned 90° to the right, and so for pendant to left when it is 90° to the left. Dial down means that the watch is lying on its face with the engraved side of the dial lowest, and dial up means that it is lying with its dial up. The temperature between 50° and 70° means that the temperature is that of the safes

without any special heating or cooling other than that of the room. The 90° temperature, however, may be as much as 95° and is obtained by the hot water boxes, commonly called the "oven" by watchmakers. So the 40° temperature test is sometimes as low as 36° or 38° and is the temperature of ice water, otherwise known as the "refrigerator test."

Now to explain the extract from the observatory regulations: The first one does not allow a certificate to a watch when its rate varies more than two seconds in any one day in the position of pendant up, except where, as in class IV., it may only be rated dial up, in which case the restriction applies to dial up. Suppose, for instance, that a watch gained as follows:

| Day. | Error of Watch. | Rate of Watch. | Variation of Rate. |
|------|-----------------|----------------|--------------------|
|      | S.              |                |                    |
| 1st, | Fast, 30.0      | S.             |                    |
| 2d,  | " 32.0          | +2.0           | S.                 |
| 3d,  | " 35.5          | +3.5           | -1.5               |
| 4th, | " 39.5          | +4.0           | -0.5               |
| 5th, | " 44.5          | +5.0           | -1.0               |
| 6th, | " 51.7          | +7.2           | -2.0               |

The amount of its rate being over two seconds of course has nothing to do with the *variation* of its rate shown in the last column. The rate of the watch is computed by subtracting the first line from the second and so on. And the variation of rate is computed by subtracting the first rate from the second and so on.

The second regulation means that the rate hanging in pendant up must not be more than ten seconds different from the rate lying or dial up. The third regulation means that if you subtract the rate in the refrigerator from the rate in the oven, and divide the difference by the number of degrees difference in temperature, the quotient shall not exceed three-tenths of one second. Lastly the fourth regulation means that whether hanging, or lying, or pendant, in any position of the class to which the watch is entered, the rate must not be greater than ten seconds per day. It will be seen that the object of the first is to secure a small daily variation of rate; for the second to see that whether hanging or lying the watch runs fairly well; the third is the requirement for temperature adjustment, and the fourth is the adjustment for position. Now, applying these regulations to the classes of certificates we see that class I. requires all the regulations to be complied with. Class II. does not require any adjustment to position with dial down, nor so long a run with pendant up. Class III. does not require any adjustment for position with pendant right or left or dial down, and the shorter run with pendant up. Class IV. requires only that a watch shall run within two seconds a day of its rate for twelve days, either dial up or pendant up as the sender chooses.

In preparing watches for these observatory trials it will not do to take the watches from the manufacturers unless these latter have specially prepared them. At the observatory the watches are never touched except to wind them. No regulation or adjusting of any kind is allowed. So if the watch is running at a rate of more than ten seconds, or if it stops for some chips of brass, or want of oil, or any of the causes which the watchmaker ordinarily removes before he sells a watch, he has all the trouble of sending the watch to the observatory for nothing, as it is returned to him without a certificate. A little care, therefore, ought to be taken before sending watches, even with the best of them, to see that they are clean and running nicely with a small rate. I offer this caution because we often receive really nice watches from dealers who assume that they are all right just as they are received from the wholesale dealer, and which only needed a little attention and a few days' running to save disappointment.

When a watch is found to fail in any of the requirements for a certificate, a report is made out of the watch's performance, and this report is often used exactly as a certificate is used, and very appropriately, for the sale of the watch. The only difference between the report and a certificate is that in the latter case the watch has

"passed" a certain standard of excellence, and has received the endorsement of the observatory. The details given in the certificates are computed from the rating and vary according to the class. The following little table shows the particulars given the various classes of certificates from I. to IV.:

| Particulars of Rating Desired.                        | Stated in Certificate of Class |     |      |     |
|---|--------------------------------|-----|------|-----|
| Mean daily rate .....                                 | I.                             | II. | III. | IV. |
| Mean variation.....                                   | I.                             | II. | III. | IV. |
| Variation for 1° Far.....                             | I.                             | II. | III. |     |
| Difference before and after oven and refrigerator.... | I.                             |     |      |     |
| Difference between pendant up and dial up.....        | I.                             | II. | III. |     |
| Difference between pendant up and pendant right....   | I.                             | II. |      |     |
| Difference between pendant up and pendant left....    | I.                             | II. |      |     |
| Difference between dial up and dial down.....         | I.                             |     |      |     |
| Difference between first and last week.....           | I.                             |     |      |     |
| Difference between the extremes of rate.....          | I.                             | II. | III. |     |

Perhaps I ought not to close this letter without saying that the last date of this year at which watches will be received for insertion in the year's official report will be April 15th, and that the observatory trials are open to everybody. I should be very glad also to receive any communications on the subject of our trials, either through the columns of THE CIRCULAR or directly, and to give them consideration. In the next letter I shall have something more to say concerning our own trials and the trials of the foreign observatories.

LEONARD WALDO.

### The Chicago Jewelers' Association.

THE SEVENTH annual banquet of the Chicago Jewelers' Association was given at the Grand Pacific Hotel in that city, on the evening of January 10. It was the most elaborate banquet of the series in every particular. The trade was generally well represented by its leading members, and a number of distinguished guests contributed their full share to the evening's entertainment. The banquet room was beautifully and artistically decorated, and the floral adornments of the tables were profuse and in most excellent taste. Hand's orchestra contributed the music for the occasion, which consisted of choice selections well rendered. The menu did full credit to the reputation of the proprietors of the hotel as caterers, and embraced all the delicacies of the season.

Mr. Otto Young, president of the association, presided, and after the viands had been disposed of and the cigars introduced, he opened the elocutionary ceremonies in a short speech, reviewing the condition of the trade in the west. In the course of his remarks he presented the following statistical information. The average production of the three watch companies was 2,400 movements per day, employing 5,300 hands, and their products have brought them not less than \$5,000,000. This includes the watch case interest in the American Watch Company. Taking their production in cases together with the three other manufacturers of watch cases and they will very nearly reach the amount of business done in movements, viz., \$5,000,000, employing perhaps 2,000 hands, and turning out about 2,100 gold, silver and filled cases per day. Our next interest is represented by three clock companies, who, with 1,900 employees, make some 4,000 clocks per day, for which they tax the world in the neighborhood of \$2,800,000. Their goods are not only sold in this country, but, as Mr. Peck assures me, Yankee clocks are not quarantined in any important part of the world. We have only one manufacturer of silver-plated ware in our Association. I don't know the number of men employed, but will estimate them at 500. Their annual business reached some \$2,400,000. The greatest difficulty I have had was in trying to compute the annual sales of the twelve wholesale jewelers, as each and every one of us does the largest business that is done in Chicago; but to take the minimum I will say that \$6,500,000 is not too large an estimate, and we do this

amount of business with less than 450 employees. According to these figures the members of this Association furnish employment to 10,150 persons, and their sales for 1883 amounted to \$21,700,000. Our Assistant Secretary informs me that our books show 9,745 names of dealers in our goods, and it is fair to state that sever-eighths of them are active, buying goods in Chicago, and of our members.

The regular toasts were then presented in order and were responded to by Mayor Harrison, ex-Governor Bross, James M. Flower, L. J. Gage, Rev. Dr. Hirsch, Dr. S. J. McPherson and others. The remarks generally were bright, witty and appropriate to the occasion, and added largely to the enjoyment of this annual festival. In every respect the affair was a success, and reflected much credit upon the gentlemen who had it in charge.

### Production of African Diamonds.

THE FOLLOWING statistical information concerning the production of diamonds in South Africa during the twelve months ending Aug. 31, 1883, may be of interest to many of our readers:

| Mines.           | Products in Karats.                   | Value in \$ |
|------------------|---------------------------------------|-------------|
| Kimberley .....  | 1,091,760 <sup>3</sup> / <sub>8</sub> | \$5,496,940 |
| De Beers.....    | 407,539                               | 2,009,120   |
| Dutoitspan.....  | 473,449                               | 3,272,655   |
| Bultfontein..... | 446,967                               | 2,472,065   |

It is difficult to estimate what the above figures may have produced in cut stones, considering the fact that a large portion of the diamonds found are not fit for cutting, and are only valuable for mechanical purposes.

AMONG THE patents issued in December last was one to Rudolph Heusch, of Washington, who has assigned a half interest therein to Max Goldsmith, for a winding indicator for watches. An indicator responding to a small scale on the dial of a watch, is designed to show the tension upon the mainspring at all times. By the use of this the owner of a watch can tell at a glance the condition of its mainspring, whether it needs winding or not, and will be prevented from winding too tightly and thus injuring his watch. The mechanism by means of which this indicator is governed is described as very simple, and can be readily attached to any watch without interfering with the movements. The inventor says: "It is the particular aim of my invention to adopt the improvement to be operated by a very slight expenditure of power on the part of the usual train or movement, to adopt it for application without changing the movement in other respects, and to avoid interference with the usual action of other parts." Various attempts have been made heretofore to combine an automatic winding indicator with a time movement, and while some of these have been successful under peculiar circumstances, they have not been suitable for all kinds of watches. Mr. Heusch claims that his invention is applicable to all kinds of movements. The desirability of such a device has long been admitted; it would prove a great convenience to thoughtless or absent-minded owners of watches to be able to ascertain by a glance at the dial of their watches whether they need winding or not. It is the intention of Mr. Goldsmith to bring this invention to the attention of the trade at once.

### Business Changes.

Monroe Marx has been admitted to the firm of Kossuth Marx & Co.

Francis R. Appleton has been admitted to the firm of Robbins & Appleton.

H. G. Smith & Co., of Providence, will hereafter be known as Smith & Greene.

Miller & Beam have dissolved; the business will hereafter be conducted by English & Miller.

Cook, Groeschel & Co. have dissolved by mutual consent. G. W. Cook continues business at 191 Broadway.

Schilling & Nissen have dissolved; the firm will hereafter be known as Ludwig Nissen & Co.

Dorrance, Edge & Co. have dissolved by mutual consent, Mr. Dorrance retiring. The firm will hereafter be known as W. C. Edge & Sons.

Sauer & Schroeter succeed the late firm of Loehr & Koerner. The latter firm still retain an interest in the new firm as special partners.

G. A. Hardy and E. H. Cox have formed a co-partnership under the firm name of G. A. Hardy & Co., and will conduct a jobbing jewelry business in Chicago.

G. C. Groeschel and D. P. Rosman have entered into a co-partnership under the firm name of Groeschel & Rosman for the purpose of conducting a manufacturing jewelry business.

Hodenpyl, Tunison & Co. have dissolved by mutual consent, Mr. Tunison retiring. Mr. Hodenpyl will continue the business with his two sons, under the firm name of Hodenpyl & Sons.

L. & M. Kahn have dissolved by limitation, I. W. Freedman retiring. Louis Kahn, Moses Kahn and Samuel H. Levy have formed a co-partnership and will continue the business under the firm name of L. & M. Kahn & Co.

The firm of Buerk & Hausburg has been dissolved by mutual consent, Mr. Buerk retiring and returning to Europe. The manufacture of the Watchman's Time Detector will be continued by Mr. Hausburg at 73 Nassau street.

The firm of Howard & Sherrieble has been dissolved by limitation, Sterns Hutchins retiring. H. Howard, A. J. Sherrieble and S. C. Howard will continue the business under the firm name of Howard, Sherrieble & Co.

The co-partnership existing between Riechhelm & Koester has been dissolved by mutual consent, C. F. Koester retiring. The business will be continued by E. P. Riechhelm and Chas. A. Liebman under the firm name of E. P. Riechhelm & Co.

### Recovering Silver from Cast Iron Crucibles.

CAST IRON crucibles are generally used for smelting silver in large establishments, and since the former absorb a certain part of the metal it becomes necessary to recover it. Such a cast iron crucible can be used from ten to fifteen times for smelting silver, but at this point the cracks have become so considerable that they must be thrown aside. They were formerly broken up and the bottoms and other portions containing a certain amount of silver were thrown in to the mother liquor remaining from the crystallization of sulphate of copper. This liquor is not easily utilized in any other manner; but when the iron is thrown in the copper precipitates, while the iron goes into solution. The cement copper prepared in this manner and containing all the silver together with the graphite, silica and other insoluble constituents of the cast iron, is treated in the usual manner to effect the separation of the silver.

This process is tedious, however, and the quantity of material to be treated is increased in place of being diminished, as 100 pounds of cast iron furnish about 113 pounds of cement copper.

A method for overcoming this difficulty was prepared by a former director of the mint at Vienna. The crucibles are first broken up and next dissolved in dilute sulphuric acid without heat. In order to avoid the trouble of evaporating a large quantity of water to crystallize the green vitriol, the sulphuric acid was only moderately diluted in the first experiment, and consequently large quantities of anhydrous protosulphate of iron, separated, which enveloped the undissolved fragments of iron thus protecting them from the action of the acid. When the acid was diluted to 20° B., however, the iron dissolved rapidly. When chamber acid can be obtained easily, it would doubtlessly be the cheapest agent. Even with acid of 60° B., the process is not expensive, and it offers the advantage that the heat developed in diluting it assists the reaction as accelerates solution. The iron is to be dissolved in wooden lead-lined vessels from 4 to 5 yards long, 2 yards wide and 20 inches deep, provided with a grating made of laths raised about 8 inches above the bottom on which the pieces of crucible are laid. Accordingly as the solution becomes more concentrated it sinks to the bottom, and the iron is constantly brought in contact with fresh acid. The very malodorous gases emanating from the vessel can be confined by taking the precaution of tightly covering it.

The acid has become saturated in from ten to fourteen days, the solution settles and has a concentration of 66° B. The insoluble residue amounts to about 20 per cent. and contains all the silver, silica, graphite, ferric sesqui, oxide, copper, as well as small quantities of sulphur and phosphorous. The larger pieces of silver are picked out, while the smaller ones are obtained by sifting and amalgamating the residuum. Only the old slick and the amalgamating residue, which still contain 1.4 per cent. of silver, are worked over in the silver works.

It will be seen that this process of recovering silver is much more expeditious than that hitherto in use. It has the advantage that 80 per cent. of iron is removed before the recovery of the silver is undertaken, whereby the argentiferous material is reduced to one-fifth of its original weight. The opinion of those who have adopted it in Vienna is that it is entirely practicable, and that the green vitriol produced pays for the labor.

### Obituary.

JAMES B. GOLDEY.

James B. Goldey died at his residence, in Brooklyn, on the morning of January 23d, in the 48th year of his age. The deceased was an old and well-known traveler, and identified with the jewelry trade for over 36 years, twenty-two of which he was connected with the firm of J. T. Mauran. Some two years ago he was attacked with a bronchial trouble which medical treatment failed to alleviate. He attended to business regularly, but it was a great grief to his friends to see that he was steadily failing, a fact he would not admit to himself. He was at his office all day the day preceding his death, and transacted his regular amount of business. Mr. Goldey was one of the earlier members of the Jewelers' League, also of the Jewelers' Club, and had attained high rank in the Masonic fraternity. He was a veteran member, also, of the Commercial Travelers' Association. Mr. Goldey was a genial, whole-souled gentleman, a favorite with all with whom he came in contact, and withal, a man of the strictest integrity in all business transactions. He was buried from the State Street Congregational Church, Brooklyn, his funeral being largely attended by members of the trade. He left a widow to mourn his loss, to whom the sympathy of the trade is extended in this, the hour of her affliction.

The Goldsmith.

[By JOHANNES PRETZLAFF, Dresden.]

IT MAY be boldly asserted that there are but few branches of art industry that require so embracing a knowledge as that of the jeweler and goldsmith, wherefore a manual which contains information on the best methods for the chemical and technical operations, and offers recipes and directions to counsel and advise the workman in his occasional perplexities, will be as useful and indispensable an auxiliary as the tools he employs in his work; especially as the opportunity is not offered to every workman to become acquainted with everything pertaining to his profession.

Based upon his practical experience of many years, and working as master jeweler and goldsmith, the author has endeavored to incorporate in his work everything that should be known, at the same time seeking to condense all recipes as much as consistent to render them intelligible without mystifying them. Things which every workman should know as part of his profession have been left out. The metallurgical and alloy tables will be found very full, since the goldsmith deals principally with this part of his art.

Hoping that the reader will find the manual to be what it was intended, I have the honor to subscribe myself  
THE AUTHOR.  
DRESDEN, May, 1882.

[We pass over the introductory part treating of the general features of the precious and base metals, etc., and begin with the]

GOLD ALLOYS.

For establishing the value of the alloyed gold, 1 marc = 1/2 pound of fine gold, was taken as unit and divided into 24 karats, each karat was again subdivided into 12 grains; 1 marc = 288 grains.

When, therefore, it becomes necessary to express the fineness of a gold alloy, only the number of karats of fine gold contained in one marc of the alloy are stated; 20-karat gold, therefore, is an alloy composed of 20 parts fine gold and 4 parts of some other metal—20 parts and 4 parts = 24 parts.

|               |   |    |                 |     |    |              |
|---------------|---|----|-----------------|-----|----|--------------|
| 18-karat gold | = | 18 | parts fine gold | and | 6  | parts alloy. |
| 16 " "        | " | 16 | " "             | "   | 8  | " "          |
| 14 " "        | " | 14 | " "             | "   | 10 | " "          |
| 12 " "        | " | 12 | " "             | "   | 12 | " "          |
| 10 " "        | " | 10 | " "             | "   | 14 | " "          |
| 8 " "         | " | 8  | " "             | "   | 16 | " "          |
| 6 " "         | " | 6  | " "             | "   | 18 | " "          |

and so forth.

The fineness of alloyed gold is frequently expressed and calculated in decimals—in thousandths of its weight; for instance:

12-karat gold = 500 parts fine gold.  
500 parts addition.  
-----  
1,000 parts.

12 1/4-karat gold = 510 parts fine gold.  
156 parts silver.  
334 parts copper.  
-----  
1,000 parts.

13-karat gold = 542 parts fine gold.  
146 parts silver.  
312 parts copper.  
-----  
1,000 parts.

13 1/2-karat gold = 563 parts fine gold.  
187 parts silver.  
250 copper.  
-----  
1,000 parts.

14-karat gold = 583 parts fine gold.  
125 parts silver.  
292 copper.  
-----  
1,000 parts.

16-karat gold = 666 parts fine gold.  
114 parts silver.  
220 parts copper.

-----  
1,000 parts.

18-karat gold = 750 parts fine gold.  
83 parts silver.  
167 parts silver.

-----  
1,000 parts.

If the gold has the legally prescribed fineness it is called standard gold. This degree varies in different countries as will be seen by the following:

|         | Karats. | Grains. | Thousandths. |
|---------|---------|---------|--------------|
| England | 22      | ...     | = 916        |
|         | 18      | ...     | = 750        |
| France  | 22      | 0.96    | = 920        |
|         | 20      | 1.92    | = 840        |
|         | 18      | ...     | = 750        |
| Austria | 18      | 5       | = 767        |
|         | 13      | 1       | = 545        |
|         | 7       | 10      | = 326        |

Gold not alone becomes cheaper by being alloyed, it is also better adapted to wear, since its hardness is much increased thereby; it is well known that gold in an unmixed state is far too soft for most purposes. Gold, silver and copper are imparted a singular property by being alloyed; they become easier fusible, and require a lower degree of fusion. Gold, except when it is to have a certain color for definite purposes, is only alloyed with silver and copper, and three kinds of such alloys are used by the goldsmith: the mixed, red and white. The former is the most generally used, and its color depends upon the percentage of silver or copper, whereby it becomes paler or redder. Although pure copper alloys do not increase the hardness of the gold, still, the alloy consisting of 7 parts gold and 1 part copper is the hardest. The copper alloy of from 580 to 600 parts fine is very brittle, but this is corrected by an addition of about 60 parts zinc. Silver turns the gold pale yellow, greenish to white, and does not augment its hardness. The most commonly used 14-karat alloy is:

*High yellow.*—14 parts fine gold; 6 parts fine silver, and 4 parts copper.

*Reddish yellow.*—14 parts fine gold; 3 parts fine silver, and 9 parts copper.

*Red yellow.*—14 parts fine gold; 1 part fine silver, and 9 parts copper.

A very hard and elastic 16-karat gold, which is very appropriate for springs and pens, consists of 16 parts fine gold, 2 2/3 fine silver, and 5 1/3 parts copper; or, 16 parts fine gold, 2 parts fine silver, and 6 parts copper. The 8-karat pale gold consists of 3 parts fine gold, 4 parts Dutch metal (brass), and 2 parts copper.

COLORED ALLOYS (à quatre couleurs.)

*Green.*—2 to 6 parts fine gold and 1 part fine silver; or, 3 parts fine gold and 1 part fine silver; or, 1 1/2 parts fine gold and 3/4 or 1/8 fine silver; or, 750 parts fine gold, 166 parts fine silver, and 84 parts cadmium; or, 746 parts fine gold, 114 parts fine silver, 43 parts cadmium, and 97 parts copper.

*Bluish green.*—1 part fine gold and 1 part fine silver.

*Yellowish green.*—750 parts fine gold, 125 parts fine silver, and 125 parts cadmium.

*Gray.*—29 parts fine gold and 11 parts fine silver; or, 30 parts fine gold, 3 parts fine silver, and 2 parts steel; or, 3 to 4 parts fine gold and 1 part steel.

*White gray.*—1 part fine gold and 364 parts iron.

*High red.*—Consists of a pure copper alloy. In order not to decrease the high red color of the latter do not take much borax, and add a little cream of tartar and pulverized charcoal to the flux, or melt with Japanese copper sand.

*Brownish red.*—72 parts fine gold, 44 parts fine silver, 92 parts copper, and 24 parts palladium.

(To be Continued.)

## Workshop Notes.

**TO GRIND GLASS.**—A fine mat surface on glass may be produced by grinding the surface on a wooden wheel with wet silver sand.

—**COPPER**, fused with salt and then cooled off, is far more malleable than other copper; this is very probably due to the removal of the oxide of copper occurring therein in greater or smaller quantities.

**GOOD MUCILAGE.**—A tenacious mucilage for labels, suitable for bottles or glass, may be prepared by soaking glue in strong vinegar, then heat to boiling and add flour. This is very adhesive, and will not decompose when kept in wide-mouthed bottles.

**CAUSE OF RUST.**—The rusting of bright steel goods is due to the precipitation of moisture from the air. It may be obviated by keeping the air surrounding the goods dry. A saucer of powdered quicklime placed in an ordinary show case will usually suffice to prevent rusting of cutlery on exhibition therein.

**ARTIFICIAL CORALS.**—An admirably executed artificial coral has lately made its appearance in market which cannot be distinguished from the genuine article, except when testing it with a file; they are made in Vienna and Paris, by mixing phosphate of alumina and phosphate of copper, and exposing the mixture to hydraulic pressure.

**TO NICKELIZE IRON.**—100 grams hyposulphate of nickel and ammonia and 50 g. salammoniac are dissolved in 4 quarts boiling water, and the bright iron pieces are boiled from one-quarter to one-half hour in it. The evaporating water is to be replaced, and if the articles are not yet sufficiently coated, the process is to be repeated.

**RED STAIN FOR IVORY.**—Dip the article first in the tin mordant used in dyeing, and then plunge into a hot decoction of Brazil wood—half a pound for a gallon of water—or cochineal, or steep in good carmine ink until sufficiently stained. For scarlet, use lac dye instead of the foregoing. Horn and bone may be treated in the same manner.

**POLISHING SHELLS.**—These are cleaned by brushing them well in hot hydrochloric acid, rinsing in hot water and drying in hot sawdust from any non-resinous wood. If the shells are without a naturally polished surface, it must be brought up by means of tripoli and washleather. Some shells are ground through the outer case to show the pearly laminæ underneath.

**PERPETUAL CLOCK.**—A clock was set going at Brussels some months ago which continued to go for nine months, and has not run down when last heard of. An up-draught is obtained in a shaft by exposing it to the sun; this draught turns a fan—which winds up the weight of the clock until it reaches the top. It then works a break which stops the fan until the weight has gone down a little, when the fan is free to recommence.

**PAPER FOR WRAPPING UP SILVER.**—6 parts of caustic soda are dissolved in water until the hydrometer shows 20° B. To this solution are added 4 parts of oxide of zinc and boiled until dissolved. Sufficient water must next be added to reduce the solution to 10° B. Next dip paper or calico into this solution and dry it. It very effectually preserves silver articles wrapped in it from being blackened by sulphuretted hydrogen, which, as is well known, is contained in the atmosphere of all large cities.

**IMITATION TORTOISE SHELL.**—Horn is made to imitate tortoise shell in the following manner: Make a paste with 2 parts quicklime, 1 part of litharge, and a little soapmaker's lye or solution of caustic potash; apply it skillfully on a thin plate of horn in a way that will best imitate the natural spots of the tortoise shell, leaving the light parts untouched; let this paste dry on, then brush it off and the horn will be permanently stained. The effect is much enhanced by laying beneath it, when used, a piece of brass leaf. This staining may be varied at pleasure by substituting other colored pigments for the litharge.

**GOLD AND ORANGE PICKLE FOR BRASS.**—Smoothly-turned, stamped or polished brass articles may be coated with an excellent gold, yellow, orange, to carmine red oxide, if the articles are dipped in a mixture of 5 grams caustic soda, 50 grams water and 10 grams burned copper carbonate the shades will appear in a short time, even quicker, and its progress may easily be judged. When the color has appeared, rinse well with water and dry in fine sawdust.

**ETCHING FLUID FOR STEEL.**—We find the following praised highly for being an excellent etching liquid for steel; Mix 1 ounce of sulphate of copper, ½ ounce of alum, and one-half a teaspoonful of salt, reduced to powder, with one gill of vinegar and 20 drops of nitric acid. This liquid may be used for either eating deeply into the metal or for imparting a beautiful frosted appearance to the surface, according to the time it is allowed to act. Cover the parts it is necessary to protect from its influence with beeswax, tallow or some other similar substance.

**OXIDIZING SILVER.**—The simplest process for effecting this is the following mixture: Salammoniac, 2 parts; sulphate of copper, 2 parts; and saltpeter, 1 part; powder fine and dissolve in the least quantity of acetic acid. Warm both the articles and the mixture and apply with a camel's hair brush where wanted; or if all over, dip. Another efficient mixture is: Common salt, 1 part; saltpeter, 2 parts; and hydrochloric acid, 1 part. Powder the salts, and put them and the acid into a plumbago crucible; boil, and dip the articles, or apply to parts with a brush.

**SOLDERING.**—It becomes necessary frequently for a country watchmaker to solder, and it is well enough for him to understand the *modus operandi*. Small articles can be soldered more quickly, neatly and efficiently over a spirit lamp than with a soldering bit of any description. Clean the surfaces to be united, moisten them with a small drop of soldering fluid, place them in the required position and hold them over the flame, applying at the same time the end on a thin shred of solder. As soon as the solder melts it will float in between the parts, and their adherence in cooling will be perfect.

**BRONZE COATING OF IRON, ETC.**—In order to cover articles of iron and brass with a durable, antique bronze coating, 100 grams of protosulphate of nickel and ammonia, 100 g. hyposulphate of soda, and 50 g. salammoniac are dissolved in 10 quarts boiling water, and the well cleansed metallic articles are laid in at once. After a few minutes they have assumed a handsome lustrous bronze color. By a repeatedly and prolonged remaining in the bath sustained at a heat of from 70 to 80°, cast or wrought iron articles have become handsomely coated with sulphide of nickel, but they must be made lustrous again by cleaning, since they have become mat in color. The bath may be used again until its bluish-green color has disappeared as well as the hydroxide of iron.

**RECIPES FOR GOLD-COLORED BRASS LACQUER.**—A German workshop paper gives the following two prescriptions:

1. Dissolve 206 grams coarsely crushed tumeric root, 1 gram Oriental saffron with 700 grams alcohol for 24 hours, and filtered. In the filtrate are dissolved 206 grams gamboge, 70 grams sandarac, 70 g. elemi resin, 35 g. fine dragon's blood, and 25 g. seed lack, if necessary, by the heat of the water bath and filter again.

2. 125 parts seed lack, 125 parts gamboge and 32 parts saffron are dissolved in 2,400 parts alcohol; again, dissolve 125 parts dragon blood and 125 parts annatto, each by itself in 1,200 parts alcohol; preserve the three solutions. When to be used, mix them, and you may graduate the shade according to desire.

A good brass lacquer may also be composed according to the following recipe:

Dissolve 1 pound best shellac in 1½ to 2 liters (4 liters=4¼ quarts) of 95 per cent. alcohol. After prolonged standing about one-third of the solution will clarify. This is poured through filtering paper, and to the lacquer one-third or more of aniline yellow dissolved in alcohol is added.

## Trade Gossip.

E. Kalish, formerly with the Am. Watch Co., is now traveling for R. & L. Friedlander.

New carving knives and forks have handles of hammered silver, with a fancy ornament at the end.

Chas. Worst's jewelry store at Meadville, Pa., was destroyed by fire on the morning of the 8th ult.

G. A. Reed, formerly with John Wilson's Sons, is now in the employ of Hall, Nicoll & Granbery.

Edward E. Buder, of Columbus, Miss., was married January 29 to Miss Bessie C. Stone, of that city.

Robert W. White, Jr., assumes the management of the Meriden Silver Plate Co.'s New York business.

As necklaces are considered *passé*, those ladies who have handsome ones convert them now into bracelets.

The Washburn & Moen Manufacturing Company, of Worcester, Mass., are making very superior mainsprings.

A. Hodenpyl has left the employ of Wheeler, Parsons & Hayes to become a member of the firm of Hodenpyl & Sons.

The export of diamonds from the Cape between Aug. 1 and Nov. 30, inclusive, amounted in value to less than \$5,000.

243,000 gold, silver and rolled plate watch cases were made by the Dueber Watch Case Co. during the year just closed.

Frank E. Knight, for several years with the Meriden Silver Plate Co., has made an engagement with the Meriden Britannia Co.

Goldsmith & Kuhn have made an assignment in consequence of the alleged robbery of goods amounting to \$30,000 by their traveler.

The firm of W. B. Clapp, Bro. & Co., of Chicago, has amalgamated with Clapp & Davies, W. B. Clapp retaining an interest in the business.

A fire in Saranac, Mich., Dec. 28, destroyed C. A. Burbank's jewelry store. The fire was caused by burglars, who got into the store and fired it.

The new frosted gold flower vases look as though they had just been taken from a gold mine they are so roughened natural, and yet artistic looking.

A clock representing a tobacco bag bearing the usual revenue stamps and labels is being supplied to the customers of a tobacco manufacturing firm.

Reception cards are square, with the name and address and the reception day and sometimes the hour engraved in the left hand corner as heretofore.

A. Westen, late with the firm of C. Rosswog & Son, has taken the management of the business of the late L. A. Cuppia in the interest of the widow.

C. Powers, for several years with M. Fox & Co., has severed his connection with that house and is now under engagement with Randel, Baremore & Billings.

W. E. Balch, for the past three years traveler for Rogers, Smith & Co., is now in the service of the Meriden Silver Plate Co., and will represent them on the road.

Among favorite monogram decorations for note paper is a sunken square of a darker tint than the paper, with the monogram in a lighter shade raised upon it.

J. T. Scott & Co. will remove to their new store, No. 4 Maiden Lane, early in February. Their new quarters will be fitted up in elegant and convenient style.

Mr. Hall, of the firm of Hall, Nicoll & Granbery, will shortly lead to the hyemial altar, Miss Scott, a very beautiful and accomplished young lady of this city.

Merrick, Walsh & Phelp's jewelry store at St. Louis, was destroyed by fire in the last extensive conflagration in that city. Their loss is said to be covered by insurance.

John C. Mount, of Randel, Baremore & Billings, is now in Europe purchasing goods for the house. Mr. Powers will take Mr. Mount's place on the road during his absence.

W. D. Dreher, formerly with David F. Conover & Co., has entered into a business engagement with Wheeler, Parsons & Hayes, and will represent that house in the South.

Walter E. White & Co. have introduced an attractive line of soldered edge chain bracelets and several new designs in bands, lacepins, etc., that are becoming very popular.

Messrs. Tiffany & Co. are exhibiting a bronze modeled by the above American sculptor, and cast in bronze by Barbedienne, of Paris. It represents two centaurs at play.

The Ill. Springfield Watch Co. have just issued a special watch with combination time dial for railroad purposes. The dial indicates the old and new method of recording time.

J. Hy. Astruck, formerly with Messrs. Max Freund & Co., has entered into a business engagement with Messrs. Louis Herzog & Co., whom he will represent in the capacity of traveler.

I. W. Friedman, who recently retired from the firm of L. & M. Kahn, sailed for Europe on the 29th ult., and will return early in May with a stock of diamonds, etc., in time for the fall trade.

Strass stones have been colored by a Parisian jeweler and are illuminated from the back by means of small electric lamps that give them a brilliancy equal to that of rubies, sapphires and diamonds.

Bates & Bacon present in this number of THE CIRCULAR illustrations exhibiting their new snap-bezel cases, which they are making in both gold and filled goods. It is claimed for this case that it is entirely dust-proof.

S. C. Howard, who represented Howard & Sherrieble in this city and on the road, has been admitted to a partnership in the firm. He is to be congratulated on having received such substantial recognition of his services.

The jewelry store of H. M. Johnquist of Ansonia, Conn., was entered by burglars on the night of Dec. 30, and the show case robbed of some \$600 worth of goods. The burglars are said to have left by an early train.

Charles B. Stoppelkam will, on the 22d day of the present month complete his thirtieth year in the continuous employment of Freeman & Co. He commenced in 1854 on a salary of \$2 a week, but has had an advance since.

D. DesMendes, a diamond cutter and polisher, was recently robbed of a satchel containing \$1,500 worth of diamonds, a check for \$2,400, and \$64 in cash, by a young man in his employ, who was assisted by a confederate.

The Middletown Plate Company has recently introduced some new and elegant goods in their line, which are called the fluted designs, a very elegant style of decoration for tea sets, water sets, etc. These goods are attracting much attention.

The Howard Watch Company and the Willemin Watch Case Company, have jointly presented to Mr. S. Kaiser, the Chicago representative of H. Muhr's Sons, a very elegant gold watch, with a monogram in diamonds, as a mark of their appreciation of his services.

The trade, especially buyers and travelers, will learn with much satisfaction that a new and well-kept hotel has been opened at Meriden. The hotel is called the Winthrop, is elegant in its appointments, and equal to first-class hotels in any of the prominent cities.

The Knight Templars of Norwalk, Ohio, recently presented P. E. C. Sir C. L. Merry, a well-known jeweler of that town, a Past Eminent Commander's jewel. It is of exquisite design and workmanship and was made to order from a special design by Messrs. Wheeler, Parsons & Hayes of this city.

The Spencer Optical Manuf'g Co. will this season be represented by the following named gentlemen: W. H. Cushman, New England States; E. L. Creseling, New York and Pennsylvania; H. Vincent, N. Y. City and surroundings; E. H. Badoux, Ohio, Ind. and Mich.; A. Marschuetz, the extreme west, and J. H. Gale, the south.

The manufacturers of the celebrated Acme Lever button will present during the year many novelties in this line of goods, in addition to the numerous varieties so well known to the trade. Among the novelties are the tiger-eye stones in a variety of unique settings, white enamel for full dress, and an extensive line of gold front buttons.

At a recent meeting of the New York Jewelers' Club, a very handsome set of resolutions, handsomely framed, was presented to the proprietors of the Astor House in recognition of many courtesies received. The presentation was made by Mr. Ellison, President of the Club, and Mr. Allen accepted the gift with appropriate expressions of thanks.

F. Steffner has severed his connection with A. Picken, Jr., of Abingdon, Va., and has formed a copartnership with J. D. Robertson, of Asheville, N. C., under the firm name of Steffner & Robertson. The new firm will open with a new stock of jewelry, etc., early in February. Asheville is a thriving town of some 4,000 inhabitants and a famous summer resort for Southern families.

Fowler Brothers, who introduced and patented a new form of jet goods which they call English crape jewelry, have issued a circular warning the trade against cheap imitations that have already been got out. It was not to be expected that this firm more than any other should be exempt from the depredations of the pirates who steal every new idea as soon as it is brought out. It is to be hoped that they will prosecute all infringers of their patents or copyrights.

Mr. M. Bailey, for many years treasurer of the Waterbury Clock Company, has been compelled by ill-health to resign that position, and Mr. H. L. Wade, secretary, has been duly elected as his successor. Mr. Bailey is a gentleman well known in the trade, and is one of the most popular men in the clock industry. His courteous and affable manners won for him a host of personal friends, all of whom sympathize with him in his loss of health and wish for his speedy recovery.

Some \$20,000 worth of jewelry is alleged to have been stolen from the safes of Goldsmith & Co., No. 43 Maiden Lane, by burglars. It is thought that the burglars secreted themselves in the building, and at night made a raid on the safes, which were wholly unfit for the purpose of keeping valuables. They were old, and of styles in use long ago, and offered little resistance to the modern tools now used by burglars. The matter is in the hands of detectives, but as yet the guilty parties have not been secured.

The celluloid show-cases have achieved a high reputation wherever they have been introduced, solely on their merits and in despite of much prejudice that existed against them. They are made in imitation of all kinds of wood or stone, and to conform in color and shape to the fittings by which they are surrounded. They are susceptible of receiving a high finish, and will withstand the ravages of extreme heat and cold and all kinds of weather. The fact they are being rapidly introduced to the jewelry trade is evidence of their special appropriateness for jewelry stores.

In the window of a Bowery pawnbroker's sales store may be seen many odd things; among them badges of gold and silver formerly worn by New York Assistant Aldermen and others, bearing date from 1863 to 1873. The names of the officials are engraved on the badges. There are also badges of many clubs and valuable medals awarded as prizes. A large gold medal bears the words, "Thomas Jefferson, President U. S., 1801." It is supposed to have been an award of merit to some exhibitor. There are swords that saw bloody service during the war. A coin less in size than a gold dollar has the Lord's prayer in full engraved upon it.

On the evening of Dec. 28th, some forty of the jewelers of Minneapolis assembled at the residence of A. J. Warner, No. 15 South Ninth street, in response to invitations to attend a banquet by A. J. Warner & Co. A sumptuous spread was served. On the back of the card was inscribed, "Second annual banquet given to the jewelers of Minneapolis by A. J. Warner & Co." After the banquet, the service of which required about two hours, the guests amused themselves with billiards, cards, etc. A most enjoyable evening was spent and Mr. Warner proved himself the best of hosts. The Italian orchestra furnished the excellent music.

Our guileless friend, S. H. Hale, from the western wilds, was in town recently in attendance upon the Jewelers' League annual meeting. Being wholly unsophisticated as to city life, and seldom venturing away from home, he was not prepared for the effusive attentions paid him by some of the residents of New York. He attempted to ride across town on the tail-end of a bob-tail car, and found himself in the midst of three most affable and courteous gentlemen, who enlivened him with much agreeable chat. When the driver rang for his fare, our friend entered upon an extended search of his clothes for a nickel, and while inextricably mixed up with his overcoat and silver-headed cane, his hat was smashed over his eyes; when he recovered from his surprise, he found his affable friends had departed, and also that his watch was missing. They left him his chain with the pendant bow and crown attached, but the watch was a minus quantity. The remains have been sent to Waltham to have another watch built on them. Meantime our friend will do his best to make up for his lost time, and will derive consolation from the knowledge that he is not the first one who has been knocked out of time in one round.

The dinner recently given by Mrs. Astor is described as one of the most brilliant affairs ever given in this city. The table was placed at one end, and fairly shone with its load of rich silver, which has been in the family for years, and cost \$175,000. This consists of some of the finest pieces in the country, and there are combined in it the Russian, Queen Anne, and repoussé styles. Almost everything connected with the service was of solid silver. Two silver candelabra stood on the table, while the center was capped with a silver bowl filled with flowers. Yellow shades covered the lights of the chandelier. The silver candlesticks held imported pink waxen candles. All through the parlors there were scattered these large candlesticks.

The Iowa Legislature has presented Kate Shelby with a handsome medal valued at \$150 and \$200 in money, in recognition of her heroic act in preventing, on the night of July 6, 1881, at the risk of her life, a disaster on the Chicago and Northwestern Railroad near Moingona, Ia., which would have resulted, but for her, in an appalling loss of human life. The medal has been prepared by Tiffany & Co., of New York, and represents Kate in the act of crossing the railway bridge over the Des Moines river. Above are the words: "Heroism, Youth, Humanity;" on the reverse of the medal is the following inscription: "Presented by the State of Iowa to Kate Shelby, with the thanks of the General Assembly. In recognition of the courage and devotion of a child of fifteen years, whom neither the terror of the elements nor the fear of death could appal in her efforts to save human life during the terrible storm and flood in the Des Moines Valley, on the night of July 6, 1881."

M. Gaston Trouvé, the well-known electrician, of Paris, has lately designed a series of ornaments for ladies' wear, which consist of glass, colored and cut to imitate rubies, diamonds, etc., fitted in an envelope surrounding a small incandescent lamp of low resistance. The light shines through the pieces of glass only, and gives them all the appearance of the stones they are intended to imitate. The lamp is fed from a small battery which is carried about the person. It is composed of three pairs of zinc-carbon plates (two carbons to each zinc), or a larger number according to the current required. These plates dip in a saturated solution of bi-chromate of potash, which is contained by an ebonite cell with three compartments. The plates are fitted into a cover, which is kept securely down on the top of the cell by two bands of India rubber passed round the whole. Finally the battery is encased in two sheets of guttapercha, so as to entirely prevent any leakage. A miniature switch is carried in the pocket or elsewhere within reach, to which the battery and lamp wires are connected. The pressure of a finger on the arm of this switch makes or breaks communication with the lamp. The battery weighs (with six plates) 300 grammes, and will work about 30 minutes with a two or three volt lamp. A larger battery to work a four or eight volt lamp weighs 800 grammes.

Greeley is noted for its watchmakers. I sent my watch to the first one I heard of, and he said it needed cleaning. He cleaned it. I paid him two dollars and took it home, when it ran two hours and then suspended. Then I took it to another watchmaker, who said that the first man had used machine oil on its works, and heated the wheels so as to gum the oil on the cogs. He would have to eradicate the cooked oil from the watch and it would cost me three dollars. I paid it and joyfully took the watch home. The next day I found that it had gained time enough to pay for itself. By noon, however, it had fatigued itself so that it was losing terribly, and by the day following had unfolded its still hands across its pale face in the sleep that knows no waking. I took it to the third and last jeweler in the town. Everyone said that he was a good workman but a trifle slow. In the afternoon I went in to see how he was getting along with it. He was sitting at his bench with a dice cup in his eye, apparently looking at the digestive economy of the watch. I looked at him some time, not wishing to disturb him and interfere with his diagnosis. He did not move or say anything. Several people came in to trade and to get the correct time, but he paid no attention to them. I got tired and changed from one foot to the other several times. Then I asked him how he got along or something of that kind, but he never opened his head. He was the most preoccupied watch savant I ever saw. No outside influence could break up his chain of thought when he got after a diseased watch. I finally got on the outside of the shop and looked in the window, where I could get a good view of his face. He was asleep.—*Bill Nye.*





VOLUME XV.

NEW YORK, MARCH, 1884.

No. 2.

## THE JEWELERS' CIRCULAR AND HOROLOGICAL REVIEW



*The recognized organ of the Trade, and the official representative of the  
Jewelers' League.*

A Monthly Journal devoted to the interests of Watchmakers, Jewelers, Silver-  
smiths, Electro-plate Manufacturers, and those engaged in the  
kindred branches of art industry.

### SUBSCRIPTION:

To All Parts of the United States and Canada,  
**\$2.00 Per Annum; Postage paid.**

To Great Britain, France, Switzerland, Germany, the West Indies, Mexico, the  
Republics of South America, and Australia, \$3.00 per annum. Postage paid.

 All communications should be addressed to D. H. HOPKINSON, 42 Nassau  
Street, New York.  Advertising rates made known on application.

### Patents and Pirates.

WE OBSERVE that a bill has been introduced in Congress that proposes to reduce the term for which patents are granted from seventeen to seven years. We can conceive of nothing better calculated to damp the natural enthusiasm of inventors, and to retard the development of the resources of the country than a proposition to deprive inventors of the opportunity of profiting by their genius and enjoying the fruits of their labor. Our patent laws, as they now exist, offer opportunities for substantial rewards to inventors, by securing to them exclusive proprietary interests in their inventions for seventeen years. Under this stimulus our people have acquired a world-wide reputation for being the most ingenious race of people living. There is no nation under the sun that has made such progress in the arts and sciences or in mechanics as ours; every line of industry, from agriculture to astronomy, has been improved by our native inventors; labor has been made easier, the cost of producing the necessaries and luxuries of life has been lessened, and life itself has been made easier by the inventions of our men of brains under the stimulus of the patent laws, which secured them, if not an actual recompense for their services, at least an opportunity to earn it. Ordinarily seventeen years is a sufficient length of time to allow a patentee to make a reasonable profit on his invention; if he has devised something calculated to benefit mankind, or any particular class of persons, justice demands that he should be allowed an opportunity to reap a fair reward, but justice is also opposed to giving him the exclusive benefit of what is a necessary or desirable thing for the masses to enjoy. Therefore the law provides that the inventor shall have exclusive rights in his invention for seventeen years, after which it shall become public property, and not subject to taxation of any kind in his behalf. This is wise and proper, tending to promote invention and to secure the welfare of the people. But it has frequently occurred that, from

some cause or other, an inventor has failed to make a fair profit from his invention within the allotted time, and has been impelled to ask Congress for an extension. The rights of the inventor have been so generally recognized that Congress has seldom refused, on a fair showing, to grant the extension desired. The present law, fixing the life of a patent at seventeen years is an extension of the time previously allowed, and, we believe, provides that no extension beyond this period shall be granted. But there have always been a few persons in the country opposed to the issuing of patents at all, or giving inventors any opportunity for making anything by the exercise of their brains. A few demagogues in politics cater to this sentiment, and when they accidentally find themselves in Congress, are continually howling about the patent laws. They claim that no individual should reap a profit from ideas that are intended to benefit the public; that, in fact, all inventions should be public property and free for every one to use without regard to the inventor. We have always maintained that a person has as much property right in the products of his brain as he has in those of his hands, and certainly no one would pretend that he had not a right to fix a price on the things his hands have wrought. But the demagogues who raise the cry "free trade in patents" will always find some followers of the Commune stripe, who object to seeing others enjoying any rights they are bound to respect. Should the attempt to do away with the patent laws or to reduce the term of protection to inventors be successful, it would be a serious blow to American industry. Manufacturers and inventors should carefully observe what is going on at Washington, and take measures to make themselves heard and their influence felt on the subject.

But there is one phase of the patent laws that might be amended to advantage, and that is in regard to providing more adequate penalties for infringements, and more speedy relief to honest inventors against the depredations of patent pirates. A patent should be held to be *prima facie* evidence that its owner has vested property rights in the invention therein described, and entitle him to immediate relief when those rights are infringed upon. It ought to be sufficient for the owner of a patent to present that document to any United States Court, and, on making affidavit that his rights thereunder are being pirated, to entitle him to an injunction restraining the infringer, and compelling him to give adequate bonds for a settlement of past offences. Under the lax laws in regard to infringements, the obtaining of a patent is but a preliminary step to a long litigation, provided the invention mentioned in it is worth stealing by the enterprising pirates who make a business of such robberies. It gives no legal rights whatever; it is simply a certificate from the patent office that the person named therein claims to be the inventor of the thing described, but to secure title under it he must prosecute all infringers and obtain a judicial decision in his favor. We know of one case where a patentee fought infringers in New York courts for six years, obtained a decision in his favor on every point, and yet had to go through the same fight in half a dozen other states where infringers combined against him. In every case

the patent was sustained, but that has not prevented others from keeping up the litigation. Owing to the legal expenses incurred, this particular inventor cannot obtain adequate compensation for his patent in the seventeen years allowed. There is a well known jeweler who obtained a patent on a bracelet, and no sooner was it put on the market than it was pirated by half a dozen manufacturers, and much vexation and costly litigation has been the result. This would not be possible were our patent laws more rigid and the rights of patentees more clearly defined. Some one has wittily said that instead of laws being made for the protection of the people, they are especially designed for the benefit of the lawyers; this seems to be especially true of the patent laws. In the jewelry trade the infringement of patents is something of every day occurrence. Designers and inventors are engaged constantly in devising new forms and styles of jewelry, gold and silverware, etc.; these styles have only an ephemeral existence, being constantly succeeded by others, so that if the inventors of them are to reap any benefits from them they must do so speedily. But when a new and patented style of goods appears, it is immediately pirated by unscrupulous manufacturers and reproduced in all degrees of quality; before the original inventor recovers from his surprise and indignation the goods have had their run, and he has nothing to gain by prosecuting the pirates, and waiting the laws interminable delays to secure those rights which the patent itself ought to give him. Inventors of new designs in fine gold goods frequently find their sale destroyed because some unscrupulous manufacturer has reproduced them in base metal, and, by making them common, destroyed their market. Occasionally these pirates are prosecuted, but the law affords such opportunities for delay, and for running up bills of cost, that most inventors prefer to submit to the outrage than to waste time and money in the vain pursuit of justice in our courts. Congress will better consult the interests of the public by throwing around inventors the mantle of greater protection, thus stimulating them to greater exertion, than by robbing them of all incentive to labor by depriving them of the rewards to which that labor is entitled.

---

### Unsafe Safes.

WE HAVE repeatedly alluded to the fact that many jewelers are in the habit of keeping their stocks at night in cheap iron boxes, miscalled safes. The danger of so doing has never been more forcibly illustrated than during the past few weeks. Repeated instances have occurred of late where burglars have secured access to the stores of jewelers, forced open their safes with little labor, and successfully escaped with their contents. In each instance the safe operated upon was an old timer consisting of a thin iron shell lined with cement, with an inner thickness of soft iron or wood. Such a shell offers but little resistance to the ingenious tools of modern burglars; give them an hour undisturbed and whatever is concealed within is their property. Burglars are far more expert than formerly, and they have improved the construction of their tools in a wonderful degree; so much so that our firemen have taken a lesson from them, and every hook and ladder truck in this city now carries burglars' tools for opening doors, iron shutters, gratings, etc. The old time safes offer no more obstruction to a modern burglar than does the egg-shell to the lively chicken confined within it. But safe manufacturers have wonderfully improved the character of their goods in late years, and now make them that are not only burglar and fire-proof in name, but are actually so in fact.

Burglars are very careful to thoroughly reconnoiter a place before they attempt to rob it, and the very first thing they direct their attention to is the safe; next, they ascertain whether or not the owner is careful to put his choice stock in the safe every night; third, they find out the best way to gain access to the building at night. If they discover the safe to be a modern one of burglar-proof construction, and that the goods are put securely therein at night, they give

it up as a bad job, and cast about for some one else not so well prepared or who is less thoughtful. Our burglarious criminals are very methodical as well as skilful, and do not undertake to "crack a crib" unless all the conditions are favorable. Nothing so completely interferes with their felonious intentions regarding a jeweler's stock as a first-class burglar-proof safe. When they see the goods placed therein every night they are discouraged and demoralized. Many of our largest firms, as is well known, keep their large and valuable stocks in safes all the time, only taking them out as they are needed to show buyers. Burglars seldom attempt to rob these, for they know it would require more time to force them than they have at their disposal. Retail jewelers, however, cannot do this; they must have their goods displayed to the best advantage in show cases during the day. Too many of them are inclined to regard fire as their only foe, and are content to place their goods at night in any sort of a receptacle that holds out a promise of keeping them from the flames. Even if the safe is ruined by the fire and the goods spoiled their loss is not so great, for they are insured and there is usually some salvage. The peril they provide against is, consequently, of less magnitude than the one they, to a great extent, ignore entirely, and that is a raid from burglars. When thieves once get hold of goods so valuable as those usually found in a jeweler's store there is no salvage; the loss is total. Receivers of stolen goods are plentiful, and it takes but a short time to remove precious stones from their settings, to melt up the gold, and so deface the goods that their owner would never recognize them. When so broken and melted up they are beyond recognition, yet nearly as valuable as before, and there is no risk in disposing of them.

At present, as is well known, there are gangs of burglars "on the road" looking for opportunities to "crack the cribs" of retail jewelers; they are specially prepared for this particular line of business, and, it must be confessed, have been remarkably successful this winter. Jewelers should be prepared for them, and the best way to defeat them is to secure a first-class burglar-proof safe of modern make. It is pretty hard to ask a small dealer to spend five hundred dollars or so for a safe, but no one that carries as much as \$10,000 worth of goods can afford to be without one. They have no right in justice to their creditors as well as themselves to take the risk of being robbed by the skilled professionals who are hunting for victims. The creditor class is beginning to feel this, and to be particular in their inquiries of one seeking credit as to what means he has for protecting his (or their) goods from burglars. A good safe is conducive to its owner's credit, and the absence of one may lose him the privilege of running in debt to some cautious jobber. Next to a burglar-proof safe a trusty watchman is the best protection against burglars. In a recent insurance case it was held by the court that a man sleeping on the premises was not a "watchman" in the sense contemplated in a fire insurance policy, yet a sleeper has been found a successful preventive of burglary. Burglars do not like to encounter a man on the premises be he awake or asleep, and are likely to give him a wide berth. A loud and persistent barking dog has frequently interfered with burglarious schemes, but dogs can be easily quieted and are not, therefore, to be trusted. A good burglar-proof safe and a bright light constitute the best possible protection from burglars. But a safe is of little value unless the choice goods are kept in it at night, but when they are under lock and key in a modern safe, the owner has done about the best he can for their protection. There should be a speedy weeding out of old, antediluvian safes among jewelers, and their places supplied with more modern articles of that kind with interior burglar-proof boxes.

---

### Voting by Proxy.

AT THE annual meeting of the Jewelers' League, held last month, an amendment to the by-laws was offered providing that members not present at the annual meetings might vote by proxy. The amendment was voted down, but it is understood that it will be

revived in the future. Our judgment is that it would be impolitic and unwise to introduce into the League the practice of voting by proxy. It has been found to be fraught with danger in other organizations, and is generally discountenanced in benefit societies such as ours. It must be remembered that the League is not a speculative organization or a stock company run for the benefit of a few stockholders; it is a purely mutual benefit organization, conducted, not in the interests of its members even, but in the interests of their beneficiaries, the loved ones of the members who make this provision for them in the event of the death of their natural protector. In their interests, and for the honor and credit of the trade, it is of the first importance that individual selfishness or personal aggrandizement shall find no place in the management of its affairs. There has always been a fair representation of the trade present at the annual meetings, and among those who attend are many who stand high in the trade, and to whose fairness and integrity absent members may safely intrust their interests. It is their duty to choose from among the members an Executive Committee, and to the membership the officers are responsible. The committee is required to keep a close supervision over all the affairs of the League, and the manner in which they have performed their duty in the past is an indication that their vigilance is a sure safeguard against maladministration. Under the form of management adopted, there is little danger to apprehend from this source, and hence the non-recognition of the proxy system of voting works no hardship to those who cannot attend. Its adoption, however, would render it possible for two or three scheming men to capture the entire organization, pervert its objects, overturn its plans and defeat the purpose for which it was formed. Such things have been done quite frequently, and it was only last month that an officer of an assessment insurance company in this city undertook, by means of proxies, to turn out his associate officers and usurp the management of the concern. Timely discovery alone prevented the success of his plot. The League cannot afford to offer any temptation to anyone to attempt schemes of this nature. Members present at the annual meetings are men of sufficient character and business qualifications to designate the men to have charge of its affairs, and any attempt to introduce proxies is fraught with great danger. Fortunately the League has been blessed with able, competent, self-sacrificing officers. The President has devoted much time and research to the League in his endeavors to find out the wisest and best means of placing it on a sound and permanent footing; the members of the Executive Committee have been prompt, watchful and painstaking in the discharge of their duties; the Secretary has devoted time and money to successfully carrying on the details of the business, and, although he has a small allowance for his services, he is actually out of pocket in money expended in addition to his loss of time. These faithful officers may be taken from us, but there remains the Executive Committee, every member of which has the confidence of his fellow members, and this Committee is always in existence, for vacancies can be filled as they occur. Under this system of management, the introduction of proxies is unnecessary. The present system has been successful; when it becomes less so it will be time enough to talk of a change. This is the opinion of the writer and of many other members of the League; what the Executive Committee and the officers may think on the subject we do not know only so far as we, with others, heard them express themselves at the meeting. We believe most thoroughly in the League, and do not wish to see it exposed to intrigues to gratify selfish ambition.

#### A Confidence Operator in San Francisco.

THE JEWELERS of the Pacific coast are sharp, keen business men, and it is rare indeed that we are called upon to record instances of their being overreached by designing sharpers. Very recently, however, they were seriously victimized by an enterprising confidence operator, who played his game so shrewdly that he got

away with a considerable sum in goods and cash. He was not at all partial, but distributed his attentions equally among several of the most prominent houses. He was a young, well dressed, good looking fellow, who gave the name of George W. Marshall, of the firm of Henderson, Marshall & Co., of Los Angeles. He represented that he was about to be married to a wealthy young lady and wished to purchase some diamonds and other jewelry. At several places he made selections of goods and asked to have them laid aside for a day or two when he would call again and decide. A day or two afterwards each jeweler thus honored received a letter dated at Los Angeles, and written on letter heads of the firm of Henderson, Marshall & Co., wherein Mr. George W. Marshall stated that he would be in the city in a day or two, and as he had concluded to take the diamonds he had selected he desired to have them reserved for him. In a few days the gentleman presented himself at the store of W. K. Vanderslice & Co., and called for goods valued at \$425. He presented a handsome lithographed draft on Henderson, Marshall & Co. for that sum, but demanded a discount for cash, whereupon he was paid \$22 in currency and he walked off with the diamonds and the money. He did the same thing with John Levy & Co., getting away with goods valued at \$475 and \$25 in cash. Colonel A. Andrews was similarly victimized to the extent of \$375 and \$18 in cash. William Manning lost \$250 and Henry Meyers \$375. Others are believed to have suffered to a greater or lesser extent, but some of them prefer standing the loss to making the facts known. Of course the drafts given in exchange for the goods were worthless, there being no such firm in Los Angeles as Henderson, Marshall & Co. When this fact was discovered the bird had flown, but whether to the arms of his wealthy bride or not is not recorded. Our San Francisco friends, who do business usually on a cash basis, should be a little more cautious in accepting drafts, and at least ascertain whether or not the persons drawn on have any existence.

#### The New Electrical Bicycle Watch Movement.

WE THOUGHT it was about time for it; it comes with the regularity of chills and fever; it has the disadvantage, however, of being contagious; its periodical return can be calculated to a nicety by any half-fledged astronomer; while it lasts its victims are wholly at its mercy; there is no cure for it; in this respect it is like the seven years itch—it must run its course. We have been expecting it some months and now it has broken out. It is a new watch movement; one that is “destined to revolutionize the watchmaking industry” as usual. This announcement has been made so often that we have become used to it; yet the watch business has not been seriously revolutionized of late; this is, however, a disaster that is constantly hanging over it—the suspended sword, as it were, that is liable at any moment to sever its suspensory connections and devastate the entire watchmaking industry. It has come at last; the revolutionary watch movement has been discovered, and the obliteration of all other movements is merely a question of time—sixty or ninety days, subject to renewal. This new improvement is the work of Mr. Salomon Schisgal, the son of a watchmaker in Berditschew, Southern Russia, and it took him three months to invent, devise and perfect it. He was only nineteen years of age when he became pregnant with his new conception, went to the gymnasium at Kieff, where he was safely delivered of it after only three months incubation. It has been approved by Herr Chowison, Professor of Physics at the University of St. Petersburg, and Member of the Committee of Savants at the Ministry of the Interior. What the Professor says of it is thus recorded in the Horological Journal:

“In its remarkable simplicity this invention can only be compared with the Jablochhoff system of electric lighting. The watches are without any springs, and consist solely of two wheels. Beside being true, they have the advantage of the second hand moving in single

momentary leaps, as is the case only in very costly watches, and which is of the utmost utility for astronomical observations. These watches can also set in motion a certain number of watches of the same construction, so that they all keep exact time. The invention has convinced me that the watches can be used for the purposes of telegraphy." This remarkable apparatus is run by electricity. It is not stated that it combines the advantages of a nutmeg grater and a sewing machine, or a domestic motor with a coal scuttle, but we presume these and various other utilitarian ideas are duly set forth in the letters patent. As it consists of but two wheels—probably a big one and a little one—it would be appropriate to call it the electrical bicycle movement as we have intimated. We have often heard of these new movements that were to create "a revolution in the manufacture of watches," but the foundations of the great deep have not yet been disturbed by them, and the universe continues to gyrate in its accustomed manner. There have been watches with three wheels, without any wheels, hydraulic watches, pneumatic watches, watches for a dollar, for fifty cents, two for five cents—in fact, watches of all kinds, sorts, styles, varieties and descriptions, that were to make the everlasting fortunes of their inventors and of the capitalists who might be induced to invest money in their manufacture. Capitalists have been found credulous enough to put up money for this purpose, and this beautiful land from the Atlantic to the Pacific Ocean is strewn with the crumbling wrecks of watch companies whose products were to "revolutionize the business of watchmaking." The craze comes upon us periodically as we have intimated above; many good men have gone wrong in consequence of it; our old and esteemed friend, Aristarchus Plumbago, has been a great sufferer from this malady, and at last accounts was pining in a dismal prison whither he had been driven by the flop-over button brigade. His frightful example has no terrors it seems for Salomon Schisgal, who has produced the electrical bicycle herein alluded to. Plumbago must be rescued from confinement that he may engineer the fortunes of this new prodigy. The electrical bicycle must be introduced to this country without delay, and Plumbago is the man to do it. Come forth Aristarchus; list at the keyhole of your prison cell, oh, Plumbago! and hear the voice of a suffering world cry to you, "Come forth! incarcerated one! and introduce to us this wonderful electrical bicycle watch movement. With you as the promoter of the manufacturing department, impracticable prisoner, we soon must know this marvellous machine; without you, visionary being, the electrical bicycle and its inventor must descend into oblivion. Come forth, Aristarchus! and let the trumpet of fame sound o'er the roofs of the world the united names of Salomon Schisgal, inventor of the electrical bicycle movement, and Aristarchus Plumbago, promoter of intangible enterprises. Come forth! The universe waits for you."

P. S.—We stop the press to announce that still another watch movement has been discovered that is to revolutionize the trade; it has no wheels, no springs, no "innards" of any kind, requires neither dial, hands nor case; it does not depend on hydraulic pressure, compressed air, steam nor electricity. It was invented by Keely and is run by a Keely motor. Alas, Aristarchus! Venerable Plumbago! Like Othello, your occupation's gone. Keely needs no promoter; credulous capitalists are drawn to him like a needle to the pole; he is inventor, promoter, business manager and superintendent all in one, with a whole factory thrown in. Retire to your prison cell venerated Plumbago; go back to your gymnasium, presumptuous Schisgal; Keely is to the fore, and the electrical bicycle is knocked out in the first round. For thee, oh, Plumbago, chaos is come again.

---

#### Industrial Art Schools.

NO WORK done by that venerated philanthropist, Peter Cooper, tended so much to exalt him in the eyes of the American people as the founding of the Cooper Union, with facilities for the technical education of young men and women in the useful industries

whereby they might be able to earn their own support. Americans are pre-eminently a nation of workers; older countries may boast of their ancestors and of their "blue blood," but with us the question regarding a young man is not "what family does he come from?" but "what can he do?" The ability to *do* something to contribute towards the development of the national resources, to add to its wealth, to its knowledge, or to be able in some way to make life easier and better for his fellow citizens, is a sure passport to popular regard, and generally brings substantial rewards to the possessor of such abilities. Peter Cooper fully appreciated the necessities of our youth, and by the establishment of free industrial schools, contributed greatly to the education and advancement of thousands of young men and women. But these industrial schools are general in their nature; there is still an unoccupied field for the education of youths in special industries, and nowhere is the necessity for such education more keenly felt than in the jewelry trade. For various reasons to which we have heretofore alluded, the old apprentice system of educating boys to become competent workmen has fallen into disuse, and there is, consequently, a great scarcity of thoroughly trained skilled workmen in the trade; the demand for such is constantly increasing, and the source of supply as rapidly diminishing. There should be in every city of importance an industrial school for training boys to become expert workmen in the jewelry trade.

An important step has been taken in this direction in Newark by the Essex Art Association. An arrangement has recently been made with the association by the firm of Carter, Sloan & Co., in accordance with which upwards of forty young men in their employ are to receive careful instruction in free hand and geometrical drawing, perspective designing, etc., from competent teachers connected with the art association. A large room has been specially fitted up for this purpose, and instruction is to be given two nights a week for three months. During the summer the school will be suspended, but resumed again in the fall. The work in the school will be with especial reference to the technical requirements of the jewelry trade, and there is no question but it will result in a very decided improvement in the young men who persist in following it. Every one of these boys has at least the opportunity before him to become an artist. Some may have more natural genius than others and may progress much faster, but it can be assumed that each one will make a better workman than he otherwise would, and that the business itself will be materially advanced. We hope this example will find many followers.

---

DURING THE past few weeks there have been no less than eight robberies of jewelry stores by burglars, and two other attempts were made but the thieves were frightened off by accident. It was not due to any foresight on the part of the jewelers that these two attempts at robbery were not successful. Over a year ago we became aware of the fact that a number of burglars had resolved to devote particular attention to the jewelers of the country and had provided themselves with tools of the best description with a view to breaking open safes. We have repeatedly warned the trade that these gangs of daring men were "on the road" looking for victims, and pointed out the necessity of providing every possible safeguard for the protection of their property. Few persons, however, take a general warning as something personal to themselves. They look upon it as they do upon a well pointed sermon, as something especially designed for their neighbors, but not as being applicable to themselves. This is where they made a mistake so far as the burglars are concerned, for these chaps are wholly without prejudice, and quite as willing to rob one as another. Because a man has but a small stock of goods he must not think himself secure from attack, for if burglars get even \$200 or \$300 for a night's work they are pretty well paid. No place is too insignificant for them to rob; if they can't get "big swag" they are content with little. The small

dealer should be just as careful in protecting his stock as the larger ones; he may not have as much in value as his neighbor, but if it is all he has the loss to him would be quite as severe as though the amount were greater. It is not an expensive undertaking to provide reasonable safeguards against burglary, and no dealer, large or small, is justified in omitting them. There is no insurance against robbery as there is against fire; no indemnity for goods stolen; the loss must fall either upon the person robbed or his creditors. The next best thing is the assistance rendered to victims by the Jewelers' Alliance. As we have before explained, this organization is designed to assist its members in recovering property that may be stolen from them, and to aid in capturing and prosecuting the thieves. It has an arrangement with a prominent detective agency, in accordance with which expert detectives are at once set in pursuit of the thieves who may have robbed a member of the Alliance. Their efforts are especially directed to recovering the stolen property and convicting the thieves. The expenses of the pursuit and prosecution are borne by the Alliance. Already there have been several convictions made through its instrumentality, so that thieves begin to regard it with wholesome respect. In a case recently tried, the burglar convicted said that if he had seen the certificate hanging in the store that he robbed showing that the proprietor was a member of the Alliance, he would not have attempted the robbery. Experience has demonstrated that in cases of this kind, private detectives, whose senses are stimulated by liberal payment, are far more effective than the public police; this has certainly been the case with robberies within the trade. It costs but a small sum annually to obtain membership in the Alliance, while the advantages to be derived from it in case of an emergency are very great. It is substantially a mutual insurance company, members paying for the protection of each other. A member may never require its services, but he has the satisfaction of feeling that, in case he should be robbed, he would not only have the sympathy of all his fellow members but also their active cooperation in recovering his goods, assuming the expense of the pursuit of the thieves at a time when the robbery has rendered him less able than usual to do it himself. Every dealer in the trade should join the Alliance without delay, and thus secure the valuable protection it offers.

### Horological School.

WE HAVE received a copy of the annual report of Professor Leonard Waldo, astronomer in charge of the horological and thermometric bureaus in the observatory of Yale College. It shows excellent progress made during the past year, and also that the service rendered is being better appreciated by watchmakers, manufacturers of chronometers and thermometers. The number of movements submitted exceeded that of the previous year, and eight certificates of the first class were issued, one of the second, one of the third and four of the fourth class. The average mark for movements submitted was considerably higher than for the previous two years, an indication that manufacturers are reaping a benefit from the practical work of the observatory. During the year, 5,295 thermometers were tested and certificates issued. Considerable new apparatus was added during the year for the use of the bureaus, and the bureaus removed to the new observatory building where the clocks are kept in a specially constructed room, and the watch movements sent for trial are kept in proper fire-proof accommodations. The following is an extract from the report:

"It has been suggested to us, from various quarters, that a school of Horology is needed in this country, similar in its scope and equipment to those abroad. It has been further urged that certain courses of the Scientific School could be utilized for the instruction of technical students in this connection, and some friends of such an enterprise are willing to furnish a part of the necessary plant. Before such an undertaking can be seriously considered by the proper authorities, it will be necessary that the endowment for at least two

of the chairs of instruction should be provided for, and a sum of money for the incidental expenses of such a school be furnished by the friends of such an enterprise. A school of this character is no doubt needed by one of our leading industries, and it will not be difficult, should the financial support be furnished, to establish a course of study and manipulation which should lead to a certificate of training and ability in this direction."

The necessity for a horological school has long been felt in the trade, and here is a most admirable foundation already laid upon which to erect such an institution. The watchmaking industry is making rapid progress in this country, but there is a scarcity of scientific horologists to take charge of its development. It would be a grand and philanthropic thing for the leading manufacturers to endow the professorships referred to, and so afford an opportunity to some of our ambitious young men to thoroughly learn the science of horology. At present there is no such opportunity, and if a young man has an inclination to study horology he must work his own way without any direction or assistance except such as he can find in the text books. A number of philanthropic gentlemen have earned the lasting gratitude of hundreds of persons by endowing professorships or scholarships in colleges, thus contributing by their wealth to the education of young men who otherwise would have been deprived of educational advantages. Some of the gentlemen who have made fortunes in the manufacture of watches could scarcely do better with a portion of their accumulations than to endow a horological school. They would thus enjoy during their life time, as did the venerable Peter Cooper, the satisfaction of seeing the advantages of their benefactions, at the same time that they would lay the foundation for posthumous honors.

### The Jewelers' League.

*President*, GILBERT T. WOLOM.....Of Woglom & Miller.  
*First Vice-President*, WM. C. KIMBALL.....Of H. F. Barrows & Co.  
*Second Vice-President*, AUG. KURTZBORN.....Of L. Bauman Jewelry Co. St. Louis, Mo.  
*Third Vice-President*, JAMES P. SNOW.....Of G. & S. Owen & Co.  
*Fourth Vice-President*, HENRY HAYES.....Of Wheeler, Parsons & Hayes.  
*Secretary and Treasurer*, WILLIAM L. SEXTON.....Of Sexton & Cole.

#### EXECUTIVE COMMITTEE.

ROBERT A. JOHNSON.....Of Colby & Johnson.  
 SAMUEL W. SAXTON.....Of Saxton, Smith & Co.  
 CLEMENT B. BISHOP.....Of Carrow, Bishop & Co.  
 JOSEPH B. BOWDEN.....Of J. B. Bowden & Co.  
 GEORGE R. HOWE.....Of Carter, Sloan & Co.  
 CHARLES G. LEWIS.....Of Randel, Baremore & Billings.

THE JEWELERS' CIRCULAR is the *exclusive* official paper of the Jewelers' League, and has been selected for the publication of all matters of interest pertaining thereto. Letters or inquiries pertinent to its business or purposes, and which might interest the trade or inquirers, will herein be answered. Address *Jewelers' League*, Box 3,444, P. O., New York, or the office of THE CIRCULAR.

The following 62 applicants were admitted to membership at the meeting of the Executive Committee held Feb. 1st, 1884.

F. L. Adams, G. W. Ailman, C. F. Brinck, G. W. Church, J. J. Cohn, G. Dessauer, A. R. Dorchester, S. Dottenheim, A. Frank, A. Freund, C. Fuchs, H. S. Geer, C. Goodman, A. Hahn, L. F. Harrison, Jr., J. S. Judkins, M. J. Lampert, H. Lon, M. Meyerheim, L. Nissen, C. H. Pfeil, C. Pausch, M. A. Rogers, C. Sem, W. H. H. Sherwood, F. K. Waller, F. Wilkinson, Jr., J. W. Wertz, H. Wundoehl, N. Y. City; J. C. Hardman, W. J. McDonald, Brooklyn, N. Y.; T. B. Lewis, Binghamton, N. Y.; W. Mitchell, Amsterdam, N. Y.; G. B. Caldwell, Plainville, Mass.; J. R. Cooney, No. Attleboro, Mass.; T. J. Fox, Boston, Mass.; G. W. Harlon, Worcester, Mass.; W. H. Hill, T. M. Nichols, Wm. Pepper, Taunton, Mass.; J. F. Ward, Jersey City, N. J.; W. Becker, Jersey City Heights, N. J.; W. C. Fischer, W. Hüger, F. Meerbott, W. Rich, Newark, N. J.; W. C. Harris, Dover, N. J.; B. H. Lyon, Philadelphia, Pa.; E. N. M. Wehrle, Indiana, Pa.; C. H.

Duhme, G. H. Bishop, Cincinnati, Ohio; W. W. Bostwick, Coshocton, Ohio; N. Cohn, H. Haas, S. J. Loeb, R. N. Matson, Chicago, Ill.; A; F. Alden, Elgin, Ill.; C. Melchor, Canton, Ill.; S. O. Merrill, Morrison, Ill.; W. Anderson, St. Paul, Minn.; E. L. Ritch, Albany, Ga.; P. A. Kolstad, Palestine, Texas.

There were present at the meeting Messrs. Lewis, Howe, Saxton, Bowden, Johnson, and Secretary Sexton, President Woglom, Vice-President Kimball, and Dr. Wilbur.

Mr. Woglom nominated Mr. R. A. Johnson for Chairman of the Committee. The election was unanimous; Mr. Bowden declining a proffered nomination.

Treasurer reported balance as follows: General Fund, \$3,586.44; Benefit Fund, \$5,160.30; Permanent Fund, \$4,988.53.

12 changes of beneficiaries were granted. One member reinstated. 4 applications were rejected. 12 applications were referred for various reasons. Meeting adjourned at 10 P. M.

[Copyright Secured.]

### The Cup—Its Art and Customs.

[BY JOHN W. MILES.]

*Continued from page 7.*

REGARDING THE early German tribes, Tacitus says, that they considered it no disgrace to pass whole days and nights in continuous drinking. Beer and mead were the national drinks, and, like the Persians, important business was discussed over their potations. Drinking to excess was a characteristic of the whole nation. Health and toasts were common; drinking for wagers still more so; while the national custom of pledging strangers and wayfarers, soon gained for them the reputation of an hospitable people. Drunken tournaments were held, and Hans Sachs describes one in which twelve "beer heroes" drank from "pots and cans" a tun of beer in six hours. They had various ways of toast drinking; sometimes a man drank from two glasses at once, and again virtuous young ladies sitting by the side of respectable young men were allowed to drink simultaneously from the same goblet. Guests were not allowed to pledge any one present unless it might be a sweetheart, when the toast had to be taken in a bumper. If a guest found it difficult to keep up with the company, he might call upon any *young* lady at his side but not upon an *old* lady, as the latter were too fond of the liquor themselves. The goblets that were used were like the enormous bowls of ancient Rome and were of various materials. "Husbands presented their wives with goblets of gold on their wedding mornings, and no greater compliment could be paid by a vassal to his lord than to offer him a handsome gold drinking vessel. Such goblets were often covered with narratives of the drunken exploits of their owners" \*

The hanap was a sort of large goblet or chalice with or without a stem and resting upon feet. It was often the cup of honor, and provided for the principal guest at a banquet. It was made of earthenware, faience, silver and gold, but the most elegant of the 10th and 11th centuries was of crystal, ornamented with engraving and incrustations. In the 11th century it played a grand role, and was often mentioned by the poets and writers. In the 15th century a regular guild is recorded called "*Henapiers*," for the production of "*Henapes*" or "*Henaperie*." The hanaps was often covered and had sometimes a lock and key attached. It originated in Germany and was produced mainly by the goldsmiths of Augsburg and Nuremburg, powerful guilds having been established in both cities. The one illustrated in figure 36, from Augsburg, is of silver parcel gilt. The feet are formed of three kneeling figures holding clubs in the outer hand, and the top ornamented with beaten flower work. It belongs probably to the latter part of the 15th century, although the style is more mediæval than might be expected of a period so close to the renaissance. Figure 37 is a hanap of Nuremburg work be-

longing to the same age. It is of gilt metal, enameled and crowded with realistic details. The cover is surmounted with a representation of the citadel of Nuremburg, with houses, sloping roads, towers and bridges spanning the moat. The base and waist of the cup are encircled with galleries fortified with sentry turrets and towers while the support is given by the ordinary outworks of a fortress.



*Hanap-Augsburg, Figure 36.*

The Vidrecome was a German goblet of considerable size and usually surmounted with a cover. It was passed from hand to hand as a parting cup and each drinker was expected to drink the entire contents. Its name freely translated means "come again." There are quite a number of these extant of various styles, mostly of silver gilt. We describe one in the form of a chalice with cover, cup and base covered with bosses and *repoussé* work of flowers. The bowl is

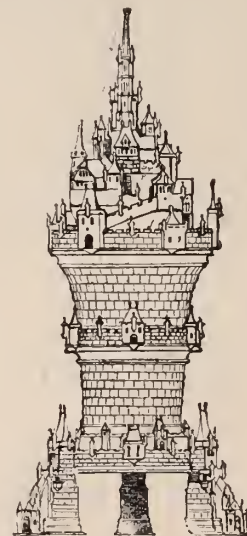

*Hanap-Nuremburg, Figure 37.*

supported by a figure in the round, representing Religion destroying heresy. The cover is surmounted with a tall bouquet of flowers. It belongs to the 12th century.

Posidonius wrote, about B. C. 100, which was before the conquest of Gallia by Cæsar, that the Gauls drank their wine from an earthenware or silver jug which was brought to the table by a slave and from which each guest in turn satisfied his thirst. Drinking from horns was also an early custom among the Gauls, that of the *urus* being especially prized. These were either gilded or ornamented with bands of gold or silver and they long continued to be considered tokens of the highest military dignity, by the nations who succeeded the Gauls. Our illustration, figure 38 represents a drinking horn of the 5th century believed to have belonged to Attila. Around the center are arranged four series of figures, the first depicting a scene from the chase, and the last a company of jugglers. The two centaurs exchanging weapons symbolize repose after warfare, and, with the griffins of the third rank, are of an oriental character. Among the numerous utensils of the table, the goblet occupied the principal position and it was accorded all the honorary privileges of the repast. The popular shape was a sort of large chalice supported by a thin

\* The History of Drink, p. 113.

stem, and these were particularly celebrated on account of their supposed ancient origin. The dissolution of the Roman nation bequeathed to the surrounding people some portion of the wealth, taste and habits that once existed in the imperial city and the Gauls



Drinking Horn of Attila, Figure 38.

undoubtedly received their share. At least they had the same fashion of prizing articles of antique design and manufacture. In the 9th century the emperor Charles the Bold presented to the Abbey of St. Denis, among other things, a goblet declared to have been formerly the property of Solomon, "which goblet was so marvellously wrought that never was there in all the kingdoms of the world a work so delicate." But the goldsmiths' art in France as everywhere else was confined to the monasteries, and the existing examples of handiwork belonging to the period are of an ecclesiastical character. St. Eloi, Bishop-goldsmith, was the patron saint of the art in France, as St. Dunstan was in England. An illustration has already been given of French workmanship in chalices during the 14th century, but guilds of secular artists had already become established at that time, although very few of their productions have been preserved. We may form some idea of the prevailing sentiments attached to articles of household plate by similar themes in ceramic art to which gold and silver work is somewhat allied. The porcelain cups of the 14th and 15th centuries, produced by the renowned masters of the time, bore painted portraits of the beauties who adorned the society of rank and fashion, and who often received from their admirers these articles with their own likeness upon them. Undoubtedly the same style of decoration was applied to precious metals either engraved and chased or in the form of small statuettes.

(To be Continued.)

### Electric Jewelry.

IN OUR July issue we alluded to this new style of electric ornaments for ladies' wear, devised by Gustave Trouve, of Paris, and recently introduced by him on the French Stage. We herewith present our readers cuts illustrating some of the objects and showing how they are constructed and illuminated.

In fig. 1, No. 1 represents a pin for a lady's head dress decorated with diamonds and rubies in equal numbers and alternating with one another. The rubies and diamonds have not the usual cut of these gems, but consist of small lenses whose foci have been accu-

rately determined. The luminous source itself always occupies an invariable position, that is to say, the center of the sphere; notwithstanding the variable dimensions of the glass vessel and the inequality of the centering of the carbon filament that it contains.

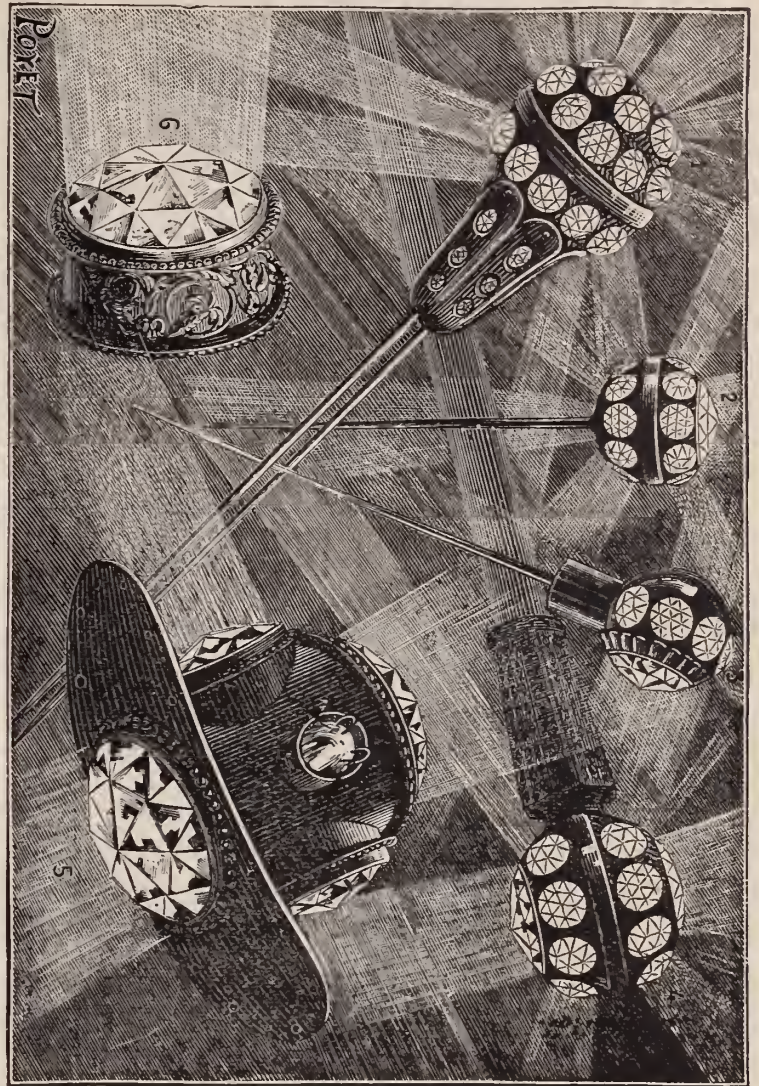

This result has been obtained very simply by Mr. Trouve, by means of a small metallic socket into which the neck of the lamp is cemented in the desired position. This socket, which in all cases is the same, occupies an invariable position in all the jewels shown in the cut, so that if an accident happens to the lamp the owner of the jewel can himself at once remedy it by opening it and replacing the injured lamp by another one provided with its conductors and its metallic socket, which latter will have in the jewel exactly the same position that the other did, that is to say, the position most favorable for producing the sparkling effects. Fig. 2 shows a section of one of these lamps, which is of 4 volts. Nothing has been neglected in order to obtain a maximum of luminous power and a simplicity in working. The lamp is connected with the little pile through the intermedium of a flexible two-wire conducting cord which is concealed under the garments. The pile is put into the pocket, or attached to some part of the dress.

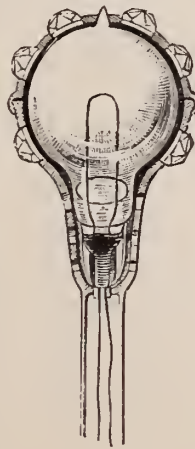

FIG. 2.

What we have said in regard to the hair pin applies to all the other jewels, so that it will only be necessary to enumerate them. Nos. 2 and 3 are scarf pins—rubies and diamonds. No. 3, in addition to the rubies and diamonds that are arranged around its periphery, is provided with a large side diamond, which projects its rays to a distance and "permits one to read his newspaper in darkness." No. 4 is the head of a cane having two rows of alternating

diamonds and rubies around the circumference, and two large diamonds which cast their rays in opposite directions. By substituting a ruby for one of the diamonds, one can at will project white and red rays, which may serve for corresponding with some one at a distance. No. 5 is a sort of diadem designed to be used in ballets. The broad rim, which contains a row of apertures, is designed for fastening the object to the danseuse's head dress. This jewel projects white, red, green, etc., lights in four directions, but, were it necessary, it could be constructed so as to project them in five, six, seven or eight. No. 6 is a large diamond designed for the necklace of a danseuse. The effects obtained from these ornaments are wonderful.

## Practical Treatise on the Adjustment of a Four-Jewel Cylinder Watch.

[First-Prize Essay by HERMANN HORMANN.]

*Continued from page 11.*

### BUSHING THE HOLES.

143. The bushing of the small pivot holes is done in the following manner:

The hole to be bushed is opened with a pivot broach to accommodate as small a screw thread as possible, which is governed by the thickness of the pivot (about Latard screw plate No. 14 to 16), the burr is removed from both sides of the hole, and a suitable thread cut in with a tap.

Drawn or hard brass wire (so-called bouchon wire), is then taken, fastened in the sliding tongs, and, after its end has been filed tapering, the same number of threads is cut upon it as that in the hole. It is then fitted into the hole, and attention paid whether it is to be longer or shorter, in order to lengthen or shorten it correspondingly.

144. If the thread fits well according to length, the fore end is filed clean and smooth, a work generally performed in the screw plate, with a few strokes of the file; the corners are next rounded off with a small oil stone, and the center is ascertained with the centering tool for the purpose of drilling the hole. This must be done with all caution, since the correct relation of the depthing is dependent upon the center of the hole in the bouchon.

When the bouchon is well centered, a pivot drill a little smaller than the pivot is to be taken, and while holding the wire horizontal, the end of the drill braced against the vise, with a requisite number of turnings a sufficiently long hole is drilled in.

The expert will barely or not at all need to revolve the sliding tongs, and drill the hole concentric; it requires much practice, however.

Next screw in the bouchon, observe well whether it is necessary that it should project or not, and break or separate it with nippers; light taps with the hammer suffice to fasten, which is unnecessary in many cases.

145. I have frequently done it in the following manner: After I had marked the center, I screwed in the bouchon at once, cut it and afterward drilled the hole. The perforation of the hole in this manner, or when a hole has been centered, is best done by placing the plate upon the bench, and drilling vertical, by exerting a gentle pressure upon the drill, revolving the plate repeatedly, however. (The uprighting machine may be used for this purpose). This manner of working is preferable to the preceding, for the reason that it is not necessary to drill deeper than is required, and it is to be recommended, especially when working hurriedly, when several holes have to be drilled at once, to perforate them all at one time in this manner.

Many watchmakers, when drilling, hold the plate in the left hand, brace the drill in a hole on one side of the vise, and drill the hole vertically after a little practice and the necessary care.

146. The uprighting of a hole is for the purpose of truing an oblique wheel. It is unconditionally necessary for this work that the

uprighting tool be true, that the oil sink, in which the upper centering point is inserted, be not oblique or unequal, that the bouchon be not too small, whereby the hole comes to stand in its joint, and that when it becomes necessary to upright upon a bridge, this has a firm support and does not spring, otherwise a wheel cannot be placed true. In the case of a bridge, therefore, it is necessary to lay a small piece of wedge shaped pegwood underneath.

147. A hole to be uprighted is carefully closed to keep from injuring the gilt oil sinks, by screwing in the bouchon; it is then riveted with a small round punch, which does not touch the sink; filed flat from below, and the hole after uprighting is then drilled through in the same manner as described above.

A pivot hole is always broached from the inside until the pivot fits; then use a chamferer upon the plate to give the necessary shake. If the underlay in riveting was a nicely polished anvil, and the shake suffice, it is not necessary to chamfer. Next make the oil sink from the outside.

148. As regards the oil sinks, the views of watchmakers differ. One is in favor of large, the other of small sinks; one desires that the gilding remain in them, the other prefers projecting bouchons. Unnecessarily large, flat oil sinks, as well as projecting bouchons, both labor under the disadvantage of attracting the oil from the spots where it is wanted.

149. With large sinks, the oil spreads very easily, and is contaminated by dust and fibers. With projecting bouchons, the oil cannot return again to the pivots, and the bouchon cannot accommodate the quantity of oil requisite for the pivot.

Projecting bouchons are by many inserted chiefly for the purpose of showing that the watch has been adjusted. If they are inserted only for this reason, only one should be put in into one bridge (for instance, the third wheel bridge), and attention should be paid at the same time to construct it in such a manner that the oil can reach the pivot.

150. The gilding in the sinks is to be kept from injury as much as possible, it having been experienced that the oil is retained better upon a gilt surface than upon the naked brass. If, however, the sink has not been constructed correctly in the factory, it is to be made true. For remedying the oil sinks, the countersink will be found the most suitable tool, because it produces a round and handsomely polished sink. After the oil funnel has at first been started with a three-cornered chamferer, it is deepened with a countersink sufficiently deep that the pivot becomes visible in it like a polished hemisphere; the burr is then removed from both sides of the holes, by the use of a pointed chamferer.

151. Should the pivot not be entirely faultless, it must always be polished before bushing the holes. This is done upon the Jacot lathe, by putting the drill bow upon the pulley, placing the wheel with its pivot requiring polishing into a suitable bearing, and then polishing in the contrary direction, that is, when the bow is moved downward, the file must move forward. This method is too well known to require a description.

152. The chief requirement for polishing the pivots consists of the arrangement of two well sharpened pivot polishing files, the sharp edges of which must not be rounded off, although they must not have a knife edge; that oil must be given to the pivot polishing and rounding file, is self-evident.



It happens very frequently that the lower fourth wheel pivot, if the watch shows no seconds, has been left disproportionately thick. It must be made as thick as the upper one, and the hole is in all cases to be bushed. If the bouchon is screwed in from the side of the bridge, it will become necessary to break it off. The face of the fracture is always more or less irregular, so that the flat punch cannot at once be used upon it. This face is smoothed with a very short, peculiarly shaped file, which the repairer can make himself, by cementing a small piece of file with fine cut to a bent piece of wire



which has been hammered flat at one end for this purpose, or carries a small plate.

153. When the pivots have been polished well, they are rounded off at a corresponding length. As length about triple the pivot diameter is to be accepted. The rounding off is performed upon the hole plate in a turning or pivot rounding tool. The holes in it must be sufficiently large to accommodate the bevel of the pivot, otherwise the small holes in which the pivots are revolved would ruin the polish.

154. In order to round off with contrary friction, the hair is placed upon the pulley in such a manner that the wheel turns forward when the bow is directed upward. A not very sharp small rounding file with fine cut is used for rounding off, and the rounded-off end is made of the shape of a hen's egg; it is then polished with a small sharpened rounding and polishing file.

155. The pivot shoulders must not be too large, since the adhesion of the oil is thereby increased, and they must also be turned truly round, so that a wheel, if necessary, can be rounded upon the rounding engine. It is necessary, therefore, to place a wheel with lead shoulders or bevel between the centers of the turning lathe, when a bevel is turned on with a graver with a somewhat flattened point, as is shown in fig. 27.



The oil is sought to be retained at the balance pivots by an appropriate shape of the jewel hole; it must be rounded off at the side turned to the cap jewel, as is shown in accompanying fig. at *cc*. Between the cap jewel *d* and the jewel hole *cc* must be a small space in which the oil constantly tends to the pivot. With too much space, the oil flows out, which it also does if it has been supplied in quantity.

Cylinder scape wheels also should receive as little oil as possible, and it will adhere with greater certainty; the custom of applying oil to the outer side or to the interior of the cylinder is objectionable, more especially the latter, because the oil is then attracted from the faces of the tampoons.

(To be Continued.)



Naval Institute, Washington Branch.

NOVEMBER, 1883.—U. S. N., in the Chair.

*Method of Testing Chronometers at the U. S. Naval Observatory.*

BY LIEUTENANT E. K. MOORE, U. S. N.

IN THE appropriation for the fiscal year ending June 30, 1883, provision was made for the construction of a house in which to test chronometers at different temperatures. Under that provision the present temperature room was built.

It is situated on the north side of the Observatory, in an angle of the east wing, directly in front of and connecting with the chronometer room proper. This is a cool and comparatively well-shaded place. The foundation is of brick, and starts from solid earth three feet below the surface, and reaches two feet six inches above it. From just below the surface it is made double, with an air space of the width of one brick between the walls. On top of the foundation, and made tight with cement, is placed a plate of slate; on this plate, and cemented to it, is the sill of the house.

The exterior dimensions are eleven feet eight inches square by ten feet high from the foundation to the eaves, and twelve feet to the ridge. The walls and ceilings are double, made of well-seasoned lumber, the plank being inch-thick pine, tongued and grooved, placed horizontally, leaving a clear space of eight inches between. This space is filled with dry and well-seasoned sawdust, making the sides and ceiling ten inches thick of wood.

It is covered with a tin roof, leaving an air space of from two to four feet between the upper ceiling and the roof.

There are two floors, the lower of which is on a level with the surface of the earth, and is made of ordinary pine flooring, built in, and made tight with the foundation. The upper one is at the top of the foundation, and is made of strips two inches wide by one inch thick, laid so as to leave an inch space between them, the whole covered with sheet zinc, turned up two inches at the sides, and tacked to the inner wall with thick felt between the zinc and the wall. This makes the room tight from the space between the floors, which is the ice receptacle or refrigerator, in which the air is at or near saturation when ice is used. The refrigerator is eight feet square by two feet six inches high, and is capable of holding two thousand pounds of ice. A few hundred, however, is all that will be usually required, and for this there are two troughs, one on either side of the center, six feet long by two feet wide and eight inches deep, lined with zinc, and fitted with drain pipes leading to the outside of the building. These troughs will hold three or four hundred pounds each. To get into the refrigerator there are double doors through the foundation, one at the outer and the other at the inner surface of the wall, each fitted tight with a lining of felt, leaving a space between the doors of the thickness of the foundation.

The temperature room is ten feet square by seven feet high, and is also fitted with double doors, the outer one of which connects directly with the main clock and chronometer room. Both doors are made tight with linings of felt, and the inner one has a large plate of French glass in its upper half, through which the face of the mean time standard clock can be plainly seen when the outer door is open. With this clock all chronometers are compared daily.

Between the doors and made tight with them, is a passage-way four feet long, four feet wide and seven feet high, made in the same manner as the house, with double walls and ceiling. It is large enough for two persons to stand between the doors and close one before opening the other, thus excluding a rush of outside air of a different temperature.

For lighting the room there is one window on the north side opposite the door, having a double sash. The outer one is three feet high by two feet wide, and the inner one three feet high by two and a half wide; the casing is beveled so as to admit light to all parts of the room. Both sashes are screwed in with felt between the casing and the sashes, leaving an air space of six inches between the glasses.

The room is heated by circulation of hot water (the fuel being gas controlled by electricity), and is cooled by ice in the refrigerator when a temperature is required below that of the outside atmosphere.

In a small room, two and a half feet by three and a half, and six feet high, built between the temperature and main chronometer rooms, and connecting by door with the small passage-way, is a small copper boiler, made in the shape of the frustum of a cone. The boiler and heating space underneath are covered with a casing of copper, leaving a space of half an inch between the boiler and casing, which is filled with asbestos packing.

From the top of the boiler leads the circulating pipe (of iron and an inch in diameter), which goes through the wall, where it is surrounded by asbestos packing, into the temperature room, thence twice around the room, back through the wall and into the boiler at its lowest point, making a fall of eighteen inches in circulating. A water-cock is placed on the return pipe near the boiler for drawing off the water when not in use.

Above the boiler and connecting with the circulating pipe is a supply tank of galvanized iron, holding about one gallon of water. This is fitted with an opening at the top for filling, a glass water-gauge at the side, and a waste-pipe leading from the top out through the side of the building. This latter is a safety as well as an overflow pipe, for should the control cease to act and too much heat be generated, the steam would escape through this pipe and relieve the pressure in the circulating coil.

A gas pipe leads from the main pipe of the observatory through the foundation up into the temperature room, with its main cock just above the floor. Thence the pipe is led up the wall about four feet, over a little shelf; thence down to the floor, through the wall into the heating room, and under the boiler where the two Bunsen burners are attached. In the horizontal part of this pipe, over the small shelf, is a spring valve acting perpendicularly, the spring keeping the valve open. The stem of the valve projects above the box, and is worked automatically by a lever attached to the armature of an electro-magnet.

A small gas pipe leads from the main pipe, before it reaches the automatic valve, to the top of the room with its burner under a funnel-shaped ventilator, for increasing the draught and regulating the hygrometric state of the room.

Another small gas pipe leads from the same point through the wall into the heating room and under the boiler, where two minute burners are attached, the flames from which are directed, one over each Bunsen burner. These are always kept burning when the room is in use.

A two-inch pipe leads through the floor and foundation to the outside for supplying cold air as required. This, with the ventilator, is regulated by hand.

Suspended over the Bunsen burners in the hollow space of the boiler is a fire-pot to deflect the flames against the sides, and from the top of this space a small copper pipe leads up to the ceiling and out through the wall for the escape of the products of combustion. Directly under the burners, leading through the floor and out through the foundation, is a two-inch lead pipe to carry off condensed vapor and to supply oxygen to the burners. A small, tight-fitting door opens into the combustion chamber.

The supply of gas is controlled by electricity through a mercurial thermostat, the stem of which is made and graduated like an ordinary thermometer, but which is open at the top.

The bulb is made of a thin glass tube coiled into a flat spiral. A fine platinum wire is fused into the end and connects with the mercury, its other end being secured to a binding-post. The thermostat is secured in a vertical position to a stand which is placed on the center of the table upon which the chronometers to be tested are placed. A small platinum wire passes down into the upper end of the thermostat, and is secured at its upper end to a binding-post on the top of the stand.

A delicate and plainly graduated maximum and minimum thermometer is also attached to the stand, and, with the bulb of the thermostat, is placed on a level with the chronometers.

(To be Continued.)

## American Gems and Precious Stones.

A Paper presented to the United States Geological Survey by George F. Kunz.

Continued from Page 9.

*Moonstone.*—Moonstone of very good quality, resembling the St. Gothard variety, and not the Ceylonese, is found at Media, Pennsylvania, and at Orange Court-house, Virginia. The quantity sold amounts possibly to over \$250 annually.

*Elæolite.*—Elæolite has been found in some abundance, and of a very compact, rich, flesh, cinnamon, and yellow-brown color that would warrant its use for certain purposes in jewelry, at Magnet Cove, Arkansas.

*Obsidian.*—American obsidian is scarcely used at all in jewelry, although found in masses in California and others of the Pacific States. The Pitt River country is a well-known locality, and furnishes handsome specimens of "mahogany obsidian." The streaked marekanite, so called, has been used, but to a very limited extent, probably amounting to not more than \$100 annually.

*Chlorastrolite.*—Chlorastrolite is found only at Isle Royal, Lake Superior, where it occurs in the form of rolled pebbles which have fallen or worn out of the trap rock. They are entirely opaque, of a green color, mottled with stellations, and admit of a high polish. It is one of the few strictly American gems. Large numbers are sold annually to tourists who visit the Lake region. Chlorastrolites measuring one inch in length and of good color have sold for \$50. The annual sales amount to fully \$2,500.

*Thomsonite.*—Thomsonite is found at Grand Marais, Lake Superior; in color flesh-red, with zones of green, red, and white, resembling the eye-agate, the peculiarly soft tones of color making it a very pretty stone. It is cut to some extent, and possibly from \$500 to \$750 worth is sold every year, principally to tourists.

*Diopside.*—This mineral has been found at De Kalb,\* New York, in short, stout, oily green crystals, in color resembling the crystals from Ala, in Piedmont. Specimens have been found sufficiently large and clear to cut into gems weighing from 6 to 8 karats each, and recently crystals have been obtained which, in size and perfection, rival the foreign, and some will furnish gems of 12 to 15 karats each. This is the only known locality for this gem in the United States.

*Opal.*—Opal has not yet been found in the United States of sufficient merit to entitle it to the name of a gem.

*Willemite.*—This stone† has been found sufficiently transparent at Franklin, New Jersey, to make a very fair gem. The color is of a rich yellow, in shade between the topaz and chrysoberyl from Brazil, with the vitreous luster of the Tavetsch titanite. One crystal furnished seven gems, one of them weighing over 8 karats. As this gem occurs in colors of rich brown and one of the richest greens, we may in time expect to see gems in both these varieties.

*Rhodonite.*—Rhodonite is found in a number of localities in the United States. At Cummington, Massachusetts, it occurs in fine large pieces of a rich red color, occasionally beautifully streaked with the black oxide of manganese, equal in every respect to the finest from Russia. It also occurs in pink and flesh colored masses mixed with rhodocrocite, at the Alice mine, Butte City, Montana. It has been very little used in the arts.

*Bowenite.*—This variety of serpentine is found in some quantity at Smithfield, Rhode Island. Its rich color, peculiar toughness and hardness recommend its use where jade has heretofore been employed.

*Williamsite.*—This variety of serpentine from Texas, a town of Lancaster county, Pennsylvania, has been used to a limited extent as a substitute for jade, it being more easily cut and usually of a more pleasing color. The amount realized from this stone is not more than \$100 per annum.

*Fluorite.*—Fluorite has been found at many localities in the United States, some of the richest colors in Hardin county, Illinois, at Rose Clare, Shawneetown, and Elizabethtown. In the mounds in this region it is occasionally found shaped into ornaments by the hand of prehistoric man.‡ This is the only use it has had as yet as an ornament in the United States. The amount mined here for the arts figures over \$15,000 per annum.

*Fossil coral.*—The fossil corals found in Iowa, near Dubuque, have been used to some extent in jewelry, shaped into stones for cuff, shirt, and vest buttons, the light cream color making a very quiet, rich stone for this purpose. The amount used is less than \$250 per annum.

*Malachite.*—Malachite, although occurring in many localities in the United States, and in considerable abundance at times as one of the ores, or associated with the other ores of copper, is however very rarely found in a form fit for cutting, and no cut specimens have come under our notice.

*Jet.*—This substance has been found in abundance and of very

\* New York Academy of Sciences, March, 1882.

† Collection of F. A. Canfield.

‡ Collection of G. F. Kunz.

good quality in El Paso county, Colorado, and in some parts of Texas. As yet it has not been utilized in the arts, although it is likely to be at no distant day. A large number of pieces have been polished for cabinet specimens, and the sale of these in the last seven years has probably amounted to several thousand dollars.

*Andalusite* is found at a number of localities, and recently in crystals one inch in diameter and six inches long at Gorham, near Sebago lake, Maine; yet no transparent gem stones have been furnished from any American locality.

*Chiastolite (macle)*.—Many hundred beautiful crystals of this mineral, with its curious cross-like markings, have been found; yet no use has been made of it for gem purposes, although a number are sold abroad for this purpose. There are occurrences at Lancaster, Massachusetts, and in California.

*Natrolite* occurs at many localities in beautiful crystals, but too small to cut for gems.

*Catlinite (pipestone)*.—This mineral is found in large beds in the upper Missouri region, and in Pipestone county, Minnesota. As yet it has only been used by the Indians. It would furnish a cheap ornamental stone.

*Axinite* has not been found in fine or large enough crystals to furnish gems.

*Titanite (sphene)*.—This mineral is met with in abundance in fine black and brown crystals, yet no gems have been found in the United States, although it occurs in such rich, vitreous, yellow gems in Switzerland.

*Cassiterite* has not been observed except in fractured crystals, and none have been found clear enough to cut even a small gem. The wood-tin of Durango, Mexico, is used to a very limited extent on the Pacific coast, the stone being simply polished flat.

*Amber* has been found at Gay Head, Martha's Vineyard, and Nantucket, Massachusetts; at Harrisonville, § Gloucester county, near Trenton, near Camden, and all through the marl region of New Jersey, and at a number of other localities in the United States; but only rarely of a quality or in sufficient quantity to warrant its use in the arts.

*Jadeite*.—An impure variety is found near Easton, Pennsylvania; and it has recently been brought from Alaska in the form of ornaments, and has also been found in place there. This mineral has not been used in the arts as yet from any American locality.

*Ilvaite*.—This mineral has not been found in compact or large enough pieces to afford gem stones.

*Lapislazuli* has not been found at any American locality.

*Pyrite* is found in beautiful crystals, and in compact masses of a fine yellow color at many American localities, notably in Gilpin county, Colorado. It has little or no value as an ornament, although it has been used to some extent abroad in former times.

*Sodalite* is found associated with cancrinite, elæolite, and in fine blue patches and masses, some several inches across and one inch thick. Fine pieces are of rare occurrence, and the stone is only a mineralogical gem.

*List of gem stones known to occur in the United States.*

- |                            |                          |
|----------------------------|--------------------------|
| Achroite (tourmaline).     | Chlorastrolite.          |
| Agate (quartz).            | Chondrodite.             |
| Agatized wood (quartz).    | Chrysolite.              |
| Almandine (garnet).        | Danburite.               |
| Amazon stone (microcline). | Diamond.                 |
| Amber.                     | Diopside (pyroxene).     |
| Amethyst (quartz).         | Elæolite (nephelite).    |
| Aquamarine (beryl).        | Emerald (beryl).         |
| Asteria.                   | Epidote.                 |
| Beryl.                     | Essonite (garnet).       |
| Bloodstone.                | Flèche d'amour (quartz). |
| Bowenite (serpentine).     | Fluorite.                |
| Cairngorm (quartz).        | Fossil coral.            |
| Catlinite.                 | Garnet.                  |
| Chalcedony (quartz).       | Grossularite garnet.     |
| Chiastolite.               | Heliotope.               |

- |                                |                             |
|--------------------------------|-----------------------------|
| Hematite.                      | Rock crystal (quartz).      |
| Hiddenite (spodumene).         | Rose quartz (quartz).       |
| Hornblende in quartz.          | Ruby (corundum).            |
| Idocrase.                      | Rubellite (tourmaline).     |
| Indicolite (tourmaline).       | Rutile.                     |
| Iolite.                        | Rutile in quartz (quartz).  |
| Isopyre.                       | Sagenite (quartz).          |
| Jade.                          | Sapphire (corundum).        |
| Jasper (quartz).               | Silicified wood (quartz).   |
| Jet (mineral coal).            | Smoky quartz (quartz).      |
| Labradorite.                   | Smoky topaz (quartz).       |
| Labrador spar (labradorite).   | Spinel.                     |
| Lake George diamonds (quartz). | Spodumene.                  |
| Lithia emeralds (spodumene).   | Sunstone (feldspar).        |
| Macle.                         | Thetis hair stone (quartz). |
| Malachite.                     | Thomsonite.                 |
| Moonstone (feldspar group).    | Tourmaline.                 |
| Moss agate (quartz).           | Topaz.                      |
| Novaculite (quartz).           | Turquoise.                  |
| Obsidian.                      | Venus hair stone (quartz).  |
| Olivine (chrysolite).          | Willemite.                  |
| Opalized wood (opal).          | Williamsite (serpentine).   |
| Peridot (chrysolite).          | Wood agate (quartz).        |
| Phenakite.                     | Wood jasper (quartz).       |
| Prehnite.                      | Wood opal (opal).           |
| Pyrope (garnet).               | Zircon.                     |
| Quartz.                        | Zonochlorite (prehnite).    |
| Rhodonite.                     |                             |

*List of species and varieties found in the United States, but not met with in gem form.*

- |              |                 |
|--------------|-----------------|
| Axinite.     | Ilvaite.        |
| Andalusite.  | Opal.           |
| Cassiterite. | Prase (quartz). |
| Chrysoberyl. | Sphene.         |
| Cyanite.     | Titanite.       |

*List of species and varieties not yet identified in any form in the United States.*

- |                        |                   |
|------------------------|-------------------|
| Alexandrite.           | Demantoid.        |
| Cat's-eye chrysoberyl. | Euclase.          |
| Cat's-eye quartz.      | Lapislazulite.    |
| Chrysoberyl cat's-eye. | Ouvarovite.       |
| Chrysoprase.           | Quartz cat's-eye. |

*List of gem stones occurring only in the United States.*

- |                 |                    |
|-----------------|--------------------|
| Bowenite.       | Rutile.            |
| Chlorastrolite. | Thetis hair stone. |
| Chondrodite.    | Thomsonite.        |
| Hiddenite.      | Willemite.         |
| Lithia emerald. | Williamsite.       |
| Novaculite.     | Zonochlorite.      |

[THE END.]

Lathes and Lathe Work.

BY THE MODEL WATCHMAKER.

ALL THE various attachments for other lathes which have been described in this series of papers, can almost without exception be modified to suit this style of lathe. Wax chucks will probably need no further description. A very simple form of grasping chuck is shown in fig. 1, and consists of a piece of large brass wire and a brass ring or collar. To construct such chucks take brass wire about  $\frac{1}{4}$  of an inch in diameter, turn down one end as shown at *a*, and cut a screw upon it to go into the lathe spindle. After it is fitted into the lathe arbor it should be turned taper toward the collar *C* as shown in fig. 1. It should now be centered and drilled in the direction of its axis; if the hole is to be a small one it can be drilled the entire length making it a tube in fact. The hole drilled should be nearly the same size as the wire intended to be turned in it. We will suppose we have such a chuck and there is a hole  $\frac{1}{16}$  of an inch in diameter; we next split it with a saw through the center as shown down to the dotted line *b*, and as also shown in the end view at *B*. The hole through the center can be enlarged from the end *a* to the

§ American Journal of Science, March, 1883.

dotted line *c*; although this is not absolutely necessary, this course, however, enables us to get a greater range in size of wire we could use in the same chuck. If the spindle of your lathe is hollow drilled you can with such chucks put in a piece of wire an inch and a half or two inches long. The collar *C* needs no screw to force it on if the correct taper is used, it will hold a wire (or any round object) very steady and true. The edge of the collar *C* should be milled so as to afford a good hold for the thumb and finger. About 20 sizes of chucks will grasp any size from  $\frac{1}{10}$  of an inch down to the finest binding wire; but in any size larger (than  $\frac{1}{10}$ ) it would be well not to let the hole go any further than indicated at the dotted line *b*. If one hundredth of an inch difference between each chuck is allowed it will answer. A good form of stop or universal chuck is shown at fig. 2. It is not a very difficult thing to make and will hold any wheel from 1 inch to nothing, and for freeing mainspring barrels cannot be excelled; one of its advantages is that you can adjust it so that no possible variation to exceed  $\frac{1}{1000}$  of an inch can exist. Fig. 2 shows a front view seen in the direction of its axis. In making

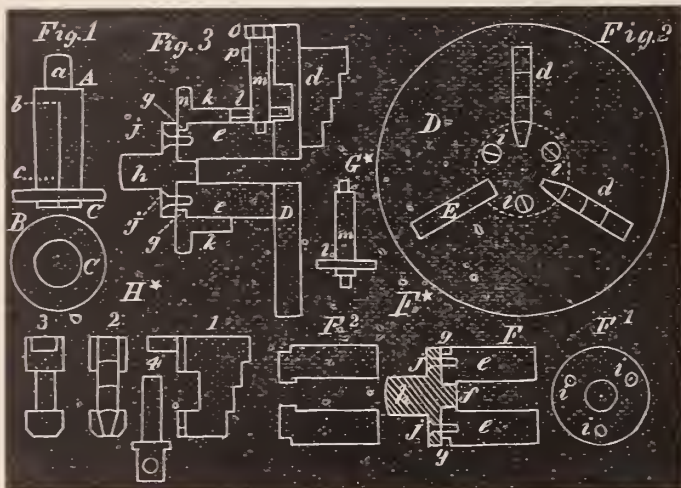

such a chuck for the style of lathe under consideration, the face plate *D* is intended to be  $1\frac{1}{2}$  inches in diameter. The cuts of universal chuck are the natural size. The thickness of the face plate *D* should be fully  $\frac{1}{8}$  of an inch after it is finished, and of the hardest brass to be obtained. If sheet brass is used the extra hard is what is wanted; and if cast brass, it should be the best red. The writer would urge whoever makes such a chuck to make it as well as lies in his power, for no matter what lathe you may subsequently use you will find this chuck one of the best tools in your box. And although made for a lathe such as described, it can readily be adapted to any lathe. The face plate *D* has 3 slots running radially as shown at *E*, fig. 2. The other two slots are shown as filled with the jaws *d d*. The face plate *D* is secured to a brass chuck *c*, fig. 2, by three screws shown at *iii*. This chuck is shown separate at diagram *F\** where *F* is a longitudinal section on a line with the axis of the lathe, and *F*, an end view seen in the direction of the axis of the lathe. The construction of this chuck is a little peculiar for the sake of adapting it to any lathe. This is accomplished by making the chuck shown at *F* of two pieces. The part with parallel lines across forming the plug which screws into the lathe spindle, and also serves as the only piece which needs be changed to adapt it to any other lathe. This will be better understood by saying that the part which fastens to the face plate *D* is shown at *F<sup>2</sup>* in longitudinal section and at *F<sup>1</sup>* in end view. The part *n* is secured to *c* by 4 screws, two of which are shown at *jj*; the part at *f* is only a guide plug so as to insure the exact centers. When the parts *n c* go together it leaves a groove shown at *g*, the use of which will be evident as the description proceeds. The diameter of *c* is  $\frac{1}{2}$  an inch and the length the same. Outside of this chuck, the sides of which are shown at *c*, fig. 3, is a sleeve shown at *k*. This is a cylindrical ring turning on *c*, and a flange which goes into the groove *g* and holds it in position. One end of this ring is cut into teeth which engage the small wheels *l* on the screw *m*. The ring *k* has a flange shown at *u*, with a milled

edge; this is to enable it to be readily turned by the thumb and finger. Fitted to the back of the face plate *D* are three screws, one of which is shown at diagram *G\**; this screw should be  $\frac{1}{10}$  of an inch in diameter and have 50 threads to the inch; and the wheel *l* should have  $\frac{3}{10}$  pitch diameter and be divided into 20 teeth. One end of these screws work or turn in a stud screwed into the face plate *D* as shown at *o*, fig. 3, while the opposite end works in a hole in the brass cylinder *c*. On the face plate *D* are three jaws, two of which are shown at *d d*, fig. 2, and one at *d*, fig. 3. These jaws are provided with three stops as shown in fig. 3. Now, if the stops measure  $\frac{1}{8}$  of an inch in a radial direction, and the jaws are capable of moving  $\frac{1}{8}$  of an inch in the same direction, these jaws, by means of their stops, will grasp any wheel from 1 inch down to (figuratively) nothing. The idea is the screw *m*, worked by the wheel *l*, is capable of moving the jaws *d* inward a trifle over  $\frac{1}{8}$  of an inch; consequently if we have a wheel we wish to turn out the center for instance, and it will not quite go into one set of stops, if the stops are drawn open as far as they will go, we can close the jaws *d* so the larger set of stops will grasp it. One of the jaws *d* is shown separate at *H\**; it should be  $\frac{1}{2}$  an inch long and  $\frac{1}{10}$  thick, and taper at the lower or rather inner end as shown. In this diagram (*H\**) the cuts are numbered 1, 2, 3, 4; 1 is a side view as seen in fig. 3; 2 is a front view as seen in fig. 2; 3 is a rear view; 4 is an end view. These jaws should be made of steel and hardened and tempered, and require to be fitted up with extreme accuracy. These jaws have a flange on each side on the back, which work in a groove on the back of the face plate. This flange prevents any lateral motion of the jaws so they advance steadily and alike. To describe the action: the stud *p* on the jaw *d* extends backward through the face plate *D* and engages the screw *m*; this screw is pivoted in the stud *o* which is fast to the face plate *D*. On turning the wheel *l* the screw *m* is turned, and the stud *p*, which is attached to the jaw *d*, is drawn toward the center. Now, it is to be understood, that there are three of these jaws (*d*), and three screws *m*, and three wheels *l*, all moved by the collar *k*, advancing at an equal rate; consequently the edge of each individual stop must be equidistant from the center. We will suppose for illustration sake that one of the jaws is a little out on releasing or rather disengaging the collar *k*, one of the wheels *l* could be revolved a tooth or two to bring the jaw to adjustment, and the collar *k* put in place, and the re-adjusted chuck is all right again. Our space will necessitate carrying the final description over to the next issue, when size and full directions will be given.

The Goldsmith.

[By JOHANNES PRETZLAFF, Dresden.]

Continued from Page 29.

SILVER ALLOYS.

For determining the value of alloyed silver the marc fine silver was divided in 16 parts, and each part into 18 grains. If, therefore, the fineness of a silver alloy is to be expressed, the number of parts contained in one marc of the alloy is stated.

The 14-part silver, therefore, is an alloy consisting of 14 parts fine silver and 2 parts of some other metal; 14 parts fine silver and 2 parts addition=16 parts.

It is more customary at present to express and calculate the fineness of silver by thousandths. According to this we have

6-parts silver=375 parts fine silver.  
625 parts addition.

1,000.

8-parts silver=500 parts fine silver.  
500 parts addition.

1,000.

10-parts silver=625 parts fine silver.  
 375 parts addition.

1,000.

12-parts silver=750 parts fine silver.  
 250 parts addition.

1,000.

14-parts silver=875 parts fine silver.  
 125 parts addition.

1,000.

Silver, as well as gold, is hardened by alloy which consists principally of copper. The good qualities of the silver are not deteriorated by being alloyed with the latter; its ductility is not essentially lessened thereby. A trifling addition even of copper increases its hardness, at the same time it does not noticeably change its color, as great a percentage as 50 per cent. even leaves it of a whitish color. Alloyed silver re-obtains its original white color by being repeatedly glow-heated and pickled in dilute sulphuric acid, whereby the copper is extracted from the surface.

The alloy of the silversmith (standard silver) contains in Prussia, Saxony, etc., 0.750=12 parts; in Austria, 0.812=13 parts; in England, 0.925=14 parts, 14.4 grains; in France, 0.950=15 parts, 3.6 grains, or 0.800=12 parts, 14.4 grains.

#### MELTING THE ALLOY OF THE PURE METAL.

For the purpose of alloying the gold or silver always the purest alloy copper or the Lyonesse copper occurring in commerce, and in order to experience no loss in the alloying add it in an already glowing condition to the fusing gold or silver, as copper is more difficult of fusion and easily burns off before it unites with the precious metal.

It is often difficult to explain why especially gold is so brittle, and no valid reason can be assigned for the occurrence; it is commendable, therefore, to pay all due care at the time of smelting. If the alloy is not melted in the crucible but upon the coal, first blow out the hole well with the flame and blowpipe to drive away any parts of sulphur and impurities; this at the same time prevents the bursting of the coal during the operation of fusing. Do not smelt without a covering coal since a higher degree of heat is produced thereby, the metal at the same time remains longer in button, the cold air also cannot enter so easily during casting, which frequently occasions the brittleness of the gold. A small piece of Venetian soap, cream of tartar or else wax may be thrown upon the metal, and while it burns off the latter is slowly poured into the ingot which has been rubbed in with olive oil or tallow; be sure, however, that the metal showed no wrinkled surface but it must have been thoroughly bright.

If the alloy calls for steel or iron, as is the case with colored gold, it is always to be added as fine wire or clean filing dust with borax, and after the metal is perfectly fused a very high degree of heat is also necessary. Before casting shake or stir the alloy well together; always remember this, as the heavier metal is apt to settle to the bottom. Both cadmium and zinc are to be added only after all the other metals are in a state of fusion, and the crucible must remain no longer than necessary in the fire to prevent their volatilization. A good shaking through is also to be observed in this instance. Should the fine or higher alloyed gold spring cracks in hammering or rolling, and if you wish to keep from smelting, you may have recourse to laying it on a flat coal, next anoint it with a thick borax paste and cause this to run over the bad places. Another remedy is to form little balls of dry salammoniac and white wax and to flux them on the spots. A small addition of zinc to alloyed gold is also quite effective sometimes.

Should these correctives not have the desired result, the goldsmith may be satisfied that his gold or silver contains metallic parts which make it brittle, and he will be forced to remelt it with potash saltpeter. In every case, however, it is to be melted clean with borax, and the lost part of alloy must be replaced. After melting with

saltpeter the gold or silver is not suited for working, and it will generally show itself to be reddish and brittle upon fracture. In the case of fine gold, many make use of the sublimated mercury as well as cyanide of potash.

Silver, especially, is not suitable for working when cast in an open ingot, since it often becomes corrugated and lamellar upon its surface. When casting silver it is better to use either a tin mold or a piece of gun barrel which has been specially prepared for the purpose. Use one with sides as thick as possible so that the ingot is easily to be gotten out.

#### PLIABLE GOLD.

If you desire to have 14-karat gold for stamping and to have it of as great a ductility as it can be had, it is better to have the alloy a little short in weight and to replace it by Dutch metal (*Rauschgold*—brass). First melt the alloy without the latter, roll it into a thin sheet, then cut it up again together with the latter and fill into a crucible in such a manner that the Dutch metal is well mixed through; fuse again and observe the general rules for smelting.

#### SMEETING THE FILING DUST.

Preserve the filing dust as free from dirt as possible, and do not glow-heat it in the glowing-pan since the heat and the draft of the furnace might carry off the finest dust particles. First draw out all iron particles with a magnet and ascertain the weight. These iron particles are not alone due to the iron binding-wire, but also to file teeth, etc.

After you have become satisfied that the crucible will not crack by having previously glow-heated it and left to cool without admission of air draught, sprinkle it with calcined soda or potash at the bottom, so that the filing dust is not carried away by the heat. Then heat the crucible slowly, and after the flux has laid hold of the filing dust apply a strong heat. Be sure to use a fully large crucible so that the flux do not boil over. Should this occur, you may assuage it by withdrawing the crucible from the fire. Some are apt to blow into the boiling flux with a pair of bellows; this, of course, increases the evil and forces the matter out.

Since the ordinary potash is frequently charged with silica, etc., and you are not sure you obtain the purified article, either take carbonate of potash or prepare a flux of 6 parts sandiver, 3 parts run salt, 2 parts cream of tartar, and 1 part borax. Let the latter, before mixing, puff up on a plate over a fire so that it become friable between the fingers.

After you may safely conclude that the filing dust has smelted completely do not pour out the metal, but let it cool in the crucible and break this. By the smelting of this as well as by that with saltpeter, the crucible had better not be used again and it is advisable to keep the button together. By ascertaining its weight you may find out whether you have had any loss in the smelting.

#### PURIFYING THE GOLD AND SILVER.

It will but seldom occur that the filing dust has been preserved so clean that it is not necessary to again purify it after melting with soda. After you have ascertained the fineness of the button by the touchstone and weighed it, take a new crucible, cover its bottom with a little potash saltpeter, and after the button is in a state of fusion add another portion of saltpeter, which you may repeat according to circumstances.

When smelted and the crucible being sufficiently cooled off, break it, remove the slags from the button and cleanse it with borax. Only after this has been done you may establish the exact fineness of the alloy by the touchstone.

#### SMEETING BENCH DIRT.

This includes old gold containing much silver or tin solder, filing dust from repairs and the collected sweeping of the work bench. After the filing has been shaken out from the sweeping by the use of a sieve, glow-heat the remainder in the glowing-pan and draw out the iron parts. As much more flux is necessary for this than for filing-dust, take a sufficiently large crucible so that no loss will occur

by running over, cover the bottom with 60 per cent calcined soda, first shake the sifted out filingdust and next the remainder into it. Keep adding portions of soda during the period of smelting; nor be too quick; leave the crucible in the fire for a prolonged time. When it has slowly cooled break the button out of the flux.

(To be Continued.)

## Problems in the Detached Lever Escapement.

BY DETENT.

WE HAVE now in, this series of articles, carried the ratchet tooth lever escapement to completion. That is, we have shown how to draw a scape wheel correctly; also the pallet and roller action. The next thing we shall do is to combine our parts, of the correct proportions, in our working model, and then proceed to consider some of the problems suggested in former articles as far as the ratchet tooth scape wheel is concerned. And after the problems involved in the ratchet tooth scape wheel is done, then give the method of drawing and constructing the club tooth lever escapement.

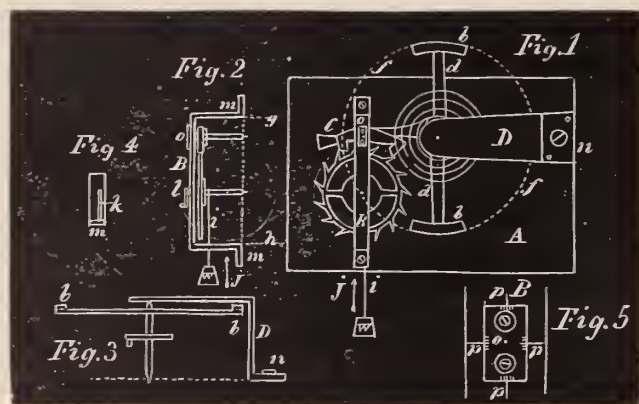

And finally, in the problems, consider and give the best methods of change and repair. To complete our model we might as well take the parts as we have drawn them and combine them in the working model. When we gave the directions for drawing the scape wheel, we spoke of the model as a whole and gave a cut showing the general arrangement; we will now give the size and details of the entire model. The board *A*, fig. 1, on which the model is mounted, should be of well-seasoned wood  $\frac{1}{2}$  or  $\frac{5}{8}$  inch thick, with battens across the back to prevent warping. In Sept., '83, number we gave a cut of the model in general form, and in it is shown a straight line lever action; since then it has occurred to the writer that a side action of the pallets would be better, for the reason that, almost without exception, the side action in this kind of escapement is in use. Consequently in considering such problems as actually occur in this kind of escapement it is better to have the escapement stand as shown in fig. 1. The board *A* is 10 by 15 inches, to which are secured the bridges *B*, *D*; *B* carrying the scape wheel and pallet staff, and *D* the balance with its staff. In the accompanying cut the proportions are supposed to be  $\frac{1}{10}$  the actual size. We have changed the length of lever from the proportion shown in the diagram given for drawing the roller action. But the reader will recollect that at the time the remark was made, that it made no difference to the action of the escapement about the length of the lever, so the relative proportions between length of lever and the diameter of the roller was preserved. In our drawing, and it would be well to preserve these proportions in the working model, the sizes are as follows: Scape wheel diameter, 5 inches; length of lever from center of pallet staff to pitch line of fork (this pitch line is explained in our last issue), 3 inches. The reason for assuming this length is that it is  $\frac{2}{3}$  of the scape wheel diameter. Radius of roller (table) from center of balance staff to pitch circle of jewel pin, 1 inch (or  $\frac{1}{3}$  of the lever length). Diameter of balance 10 inches (or twice the diameter of

the scape wheel). The length of pallet staff  $2\frac{1}{2}$  inches. Length of balance staff 4 inches. Length of the balance arms *dd* 5 inches; this will make the dotted circle *f* 10 inches in diameter. The arms should be of spring-tempered steel and the weights *bb* of brass, and weigh 4 or 5 dwts. each. The hair spring can be made of a good long mainspring of such strength that the balance will vibrate about once in 2 seconds when you first commence to study its action; but after the eye becomes accustomed to the action change the weights *bb* so they will permit the balance to vibrate every second. The model needs no regulator. The balance should be perfectly poised and it would be well if the holes to the balance staff were jeweled. The bridge over the scape wheel and pallet staff should be  $\frac{3}{4}$  of an inch wide, of No. 14 brass, and bent as shown in fig. 2; the space corresponding to the lines *gn* should be 7 inches, and the feet *mm* 1 inch long. A small permanent crank can be mounted on the scape wheel arbor as shown at *l*, fig. 2, to wind up the weight. The bridge or cock *D* over the balance should taper as shown, the end *n* being  $2\frac{1}{2}$  inches wide, while the end over the balance can diminish to 2 inches. The foot *n* should have steady pins and a wood screw. Fig. 4 is an end view of the bridge *B* seen in the direction of the arrow *j*, and the slot *k* is for the cord *i* to run through; this slot *k* should be to one side as shown to allow for the semi-diameter of the scape wheel arbor, which acts as a spool on which the cord *i* winds. The feet *mm* should have a steady pin and screw at each end. There is an extra plate attached to the bridge *B* shown at *O*; this plate is to use for adjustment, to set the pallet staff from and toward the scape wheel; there should be a corresponding one at the foot of the (pallet) staff. A good way to arrange this plate is shown enlarged in fig. 5, where *o* represents the plate secured with two screws. These screws have washers under their heads, and underneath the washers are quite large holes in the plate *o* to allow of its being moved about. It will be seen that on the bridge *B*, fig. 5, are two lines crossing at right angles forming the four lines *pppp*. It will also be seen that there are graduations on the plate *o* which will indicate the direction and distance to which the plate *o* is moved. The plate at the foot of the staff should be double, the lower one being permanent while the upper is movable and arranged like the one just described. The bridge and foot of the balance staff should be arranged in the same manner so that the correct depth can be restored with certainty in a few seconds. All the parts should be well and carefully made, and the board *A* would be well to be of some kind of hard wood; cherry, if it can be got and well-seasoned is the best; black walnut will answer, and pine by putting a permanent plate under the feet at *mm* and *n*. By a permanent plate I mean a plate of No. 14 brass, say  $2\frac{1}{2}$  inches square, under *n*, and one  $1\frac{1}{2}$  inches square under each of *mm*. These extra plates secured to the board *A* with 4 screws each. If this were done the screws holding the cock *D* and bridge *B* should be tapped into these extra plates. The parts representing the pallets as directed in former article should be made movable. The board *A*, if made of cherry or pine, would look best to be ebonized; this can be done by brushing over the wood a solution of the extract of logwood, following it with a solution of bi-chromate of potash. A few coats of shellac dissolved in alcohol will make the surface smooth, when a little sand papering with 0 sand paper will make the surface smoother. If you sand paper enough to bring up any white spots, touch them up with the logwood extract and bi-chromate. After the final coat of shellac the surface should be rubbed with fine pumice and water on a cloth to give a dull smooth look. The brass parts should all be fitted—in fact the model made complete and put in working order before it is ebonized. Then remove everything and ebonize the board, and after it is finished put back your working parts. Such a model is invaluable in the study of the lever escapement, and besides it has a tendency to impress the mass with an idea of superior skill; and if you study it faithfully my word for it you will see the advantage of the time spent. In our next we will commence the study of some of our problems.

## How to Make and Engrave Silver Bangles.

BY EXPERT.

FOR THE benefit of such readers as would be satisfied with frosted bangles of an inferior surface we will give other processes for frosting. The first one shown is on the principle with which the so called satin finish on silver and plated ware is produced. It consists of a disc or series of discs carrying a number of jointed wires, each of the wires being jointed in two places to prevent them catching and dragging on the work. We will suppose we are making a machine with only one row of wires and one disc, but any number of discs can be used. The disc shown at *A*, fig. 1, should be about  $1\frac{1}{2}$  inches in diameter and made of No. 24 brass, and near the edge (as shown) should be drilled 18 holes. I say 18 because this is a multiple of the space you have in your dividers to sweep the circle; to illustrate, say we take  $\frac{3}{4}$  of an inch in our dividers and sweep a circle  $1\frac{1}{2}$  inches in diameter; we next set our dividers to  $\frac{1}{8}$  and sweep an inner circle; now, with the space we have in our dividers, space the circle we have just described into six parts and divide these again by 3, and we have our 18 divisions. The wires for acting on the dime or article to be finished can be made of the finest (or smallest) wire used for piano strings. Such wire is steel and hard enough to indent any surface you will want to meet, and still soft enough to bend into rings. At *A*<sup>2</sup> are shown the two pieces of wire; the piece at *b* has two rings turned at the ends (as shown) with a pair of small round-nosed pliers. I should have said above that small holes are drilled at each of the 18 spaces, and into each of these holes goes one of the eyes formed by the round-nosed pliers in the end of *b*. The eye should be closed down so that the wire *b* can swing around in the hole (*d*) in *A* in any direction without cramping or flying out. At *c*, *A*<sup>2</sup>, is shown another

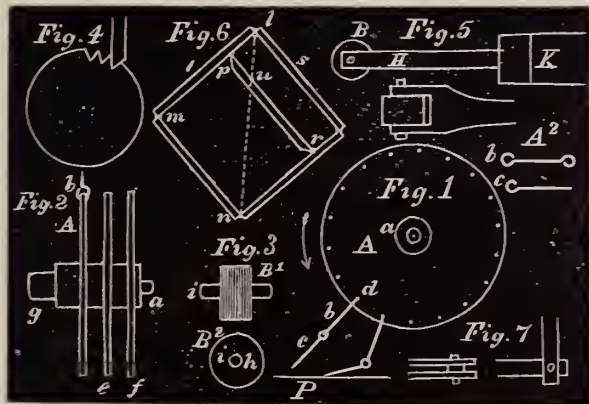

wire with an eye at one end, the other end being bluntly pointed. These wires are joined by the eyes as shown at *b c*, fig. 1. These eyes are securely set down so that they can neither get out of the holes in the disc *A* or part from each other. The 18 holes are each filled with such double jointed wires. The screw *g* is now inserted into the lathe spindle and revolved rapidly, when the centrifugal force will cause the wires to bristle out, and any object held at *P* will be struck with the revolving points of *c*. By adding more discs, as shown at *c f*, any number of rows of these wires can be set in motion. Such an arrangement produces a surface which well deserves the name satin finish, as it has a marked *satiny* look, as all the stipples are elongated, in fact, little dashes instead of dots. One more method of producing a matted surface, and we will proceed to consider other matters bearing on engraving. A rolette can be used to produce fine dots on the surface of our bangles. Such rolettes are not difficult to make, but they do not make as fine and even a surface as the machine described in Dec. number; still they are so easily made and mat a surface so quickly that perhaps some of my readers would like to try one. The rolette is made of soft steel turned first into a short cylinder and afterward cut into a large number of fine points. The method of making such points is as follows: Take a piece of very soft steel about  $\frac{3}{8}$  of an inch in diameter and  $\frac{1}{4}$  of an inch long, drill a hole through it on the line of its axis. At

*B*, fig. 3, is shown such a solid cylinder; *h* representing the hole—the hole should be about  $\frac{1}{8}$  of an inch in diameter. In this cut (fig. 3), *B*<sup>1</sup> represents a side view and *B*<sup>2</sup> an end view, *i* representing a pin put through the hole *h* to act as an arbor. The cylinder *B* should be turned into grooves as shown at *k*, fig. 3. If the cylinder is  $\frac{1}{4}$  of an inch long it should be turned into about 10 equal grooves as shown. After the grooves are turned the cylinder should be put into a wheel cutting machine and be cut into 48 teeth; these teeth should run from end to end of the cylinder. An ordinary ratchet tooth cutter can be used to cut the teeth as shown in fig. 4 if the cutter is set to one side as in the cut. After the teeth are cut the cylinder *B* should be well brushed with emery and oil to remove the burr and to slightly round up the teeth. The rolette can now be mounted in a handle as shown in fig. 5, when, by rolling the cylinder *B* back and forth across the face of the dime or other work, it will quickly present a frosted look. The rolette should be rolled across the work in different directions to ensure an even surface. There is a tendency at the present to engrave both sides of the dime or bangle; if such bangles are required to any extent it would be an economy to cut them from silver rolled out. Generally the opposite side to the monogram is ornamented with some device like a bird or a bunch of flowers. Such designs are repeated again and again and can well be copied by a pentagraph of a simple form. Such a pentagraph is also useful in producing the outline of the leading letter or letters in monograms as will be shown further along. The main thing is to get up such a pentagraph cheaply. Although an instrument can readily be made to work to any proportion, still for such work it is as well to adhere to one scale, say as 4 to 1. I mean by this make your pattern on zinc 4 times the size you wish to produce on your bangle. We will suppose we wish to copy a lyre or horse shoe; we engrave it 4 times the size required on a piece of zinc with a fish-belly graver. This zinc piece goes to a certain position every time; the dime is placed in a holder which ensures it being in the proper place, and a copy perfect in every way is given to the dime in one-half the time we could even take a transfer. The general form of such a pentagraph is shown at fig. 6. It may be well to say that there are many forms of the pentagraph and all essentially the same in principle; but what we want in the present instance is something which can be made cheaply and worked rapidly. The first essential to be considered is how to make the joints at the angles *l m n o*. As they are shown the joints are made by using small brass butts or hinges. This is undoubtedly the best cheap way of making the joints. At fig. 7 is shown a joint made by putting pins through the wooded slips used to construct the instrument. We will consider the action of the instrument shown in fig. 6, and then give the details of construction. The joint at *l* is supposed not only to unite the pieces *s t*, but to be attached to the board or table on which the pentagraph works. This board or table should be about 2 feet square and will serve to support the pentagraph and also hold the zinc piece on which the design is engraved, and likewise hold the bangle on which the design is to be traced. The cross-bar extending from *p* to *r* carries the tracing point *u* for producing the outline on the dime. The copying point for following the design engraved on the zinc is placed at the angle *n*. One of the advantages of this form of pentagraph is its steadiness and rigidity; this is secured by the pieces uniting and forming a square. In our next issue we will give details and proportions for all the parts and the method of working.

## Advice to Watchmakers' Apprentices.

BY A MAN WHO HAS SPENT TWENTY YEARS AT THE BENCH.

LAPS OF a variety of forms can be used in finishing jewelry, but in this brief notice of the jewelers' art we shall only speak of flat lapping, *i. e.*, such laps as produce a flat surface. These laps can be made of block tin, bell metal, or even rolled zinc. It must be understood that the use of such laps necessitates the loss, or rather

using up, of a good deal of time, and should be adopted only in the settings of diamonds and other rare and expensive stones. Every person who has worked gold knows that no matter how carefully a job may be filed and stoned, that after it is polished by buffing the sharp, clean corners or angles are destroyed, and it is to avoid this rounding up that lapping is employed. The great essential in such work (lapping) is to hold the job securely in position during the process of grinding and polishing. The simplest form of such work could be illustrated by a locket cover; say our job is one of Roman or colored gold and a bright polished (lapped) band surrounding the cover as shown at *c c*, fig. 1. In such a job as this it is only necessary to grind the face *c* off perfectly true on a flat piece of bell metal or tin; clean off all grit with a crumb of bread and polish on a tin lap with diamantine and oil. But with such a job as the shank of a ring as we recently illustrated, the lapping must be accomplished in a different way. Circular laps used in a lathe are the most rapid, but as in polishing steel they only produce second-class work. We will describe both and leave the reader to choose. At fig. 3 is shown a flat lap for screwing into the spindle of any foot lathe; the part *D* is a flat disc of block tin or bell metal about 2 inches in diameter, and from  $\frac{1}{8}$  to  $\frac{3}{16}$  of an inch thick, and the part *d* is intended to screw into the spindle of the lathe. The face of *D* should be turned off perfectly flat; if you have a slide rest attachment to your lathe this is easy, if not it can be done with a hand tool using a straight edge as a guide, *i. e.*, testing and turning until the straight edge touches across the face. The final surface is acquired by rubbing on a rough ground plate glass surface, turning and scraping until the surface of *D* is dead flat. There should be two of these laps, one

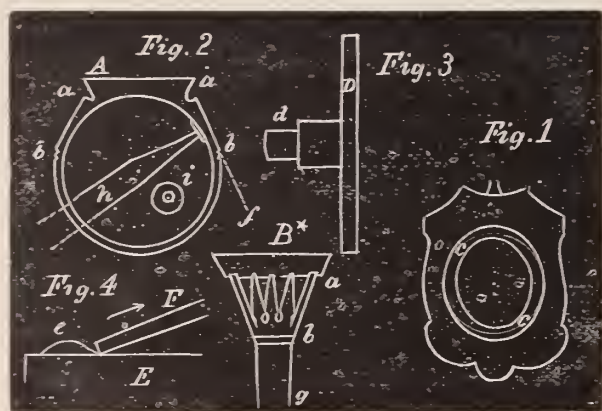

for grinding and one for polishing. Hard white flint glass ground to an impalpable powder is the best material to grind such surfaces. Take an old spectacle glass and crush it, and when reduced to comparatively fine powder, put two or three grains weight of it on a hardened steel lap, and with the back (smooth side) of a burnish file grind the dust until no coarse particles remain. The manner of grinding is shown in fig. 4, where *E* represents the hardened steel lap, and *F* the file, and *c* the fine glass moistened with a little oil. The grinding is done by taking a small portion under the point of the file and drawing it towards you or in the direction of the arrow; the motion is repeated until the whole mass is gone over several times leaving no coarse particles. Such fine glass cuts tolerably fast, and if the glass is properly ground leaves no deep scratches. The greatest advantage in using fine glass is the readiness with which the work can be freed from grit. An ordinary bread crumb (soft, fresh bread worked with the thumb and finger into a putty-like mass), this will, if the article ground is well worked into the soft mass, remove all the particles of glass. There is still a surer method of removing any and all particles of glass from a job, and this is to immerse the article in fluoric acid for a short time. This acid has the property of dissolving glass and is used by glass workers to etch on glass so as to produce beautiful designs somewhat like very delicate grinding. This acid comes in gutta percha bottles, as it would go through a glass bottle in a very short time. This acid does not attack gold. In conjunction with the use of glass as an abrasive material when it is desirable to remove *absolutely all grit* from a surface which has

been ground with it, or if the metal is hardened steel, fine flint, same as is on the surface of common sand paper, can be used, and every trace of the glass or fine flint dissolved off without disturbing the metal, by immersing it in a solution of carbonate of soda. The solution should be placed in an iron vessel capable of standing a pressure of 300 pounds to the inch, and while confined with the article which has been ground should be heated up to about  $350^{\circ}$  F., when the solution of carbonate of soda will dissolve the glass or flint readily. In this way articles can be ground and no grit left imbedded in the surface. But in the case in hand if the job is well cleaned with bread crumb as directed very little is to be feared from adhering grit. The method of using the circular lap is to screw it into the lathe, commencing with the one on which you use fine glass. At fig. 2 is shown a ring; we will commence with the edge of shank extending from *b* to *b*, fig. 2, that is, the part from *b* to *g*, diagram *B\**. This part will touch a flat lap from *b* to *b*, fig. 2, even if the part at *g* is a little narrower. It is to be supposed that our lap is slightly smeared with oil and the fine glass powder; we take the box top between the finger and thumb and with a piece of cork press the shank against face of the lap, so that the edge of the shank lies flat. It is well to have a slight notch in the shank at *b b* to lap to, as it is easier to let the lap pass over a slight notch than to finish up to an angle. It is a good precaution to perfectly polish all such parts as you intend to buff, and brush polish before you commence to lap, and then give the ring a couple of coats of shellac dissolved in alcohol to protect the polished surfaces. After the shellac is applied, the job should be heated to about  $400^{\circ}$  F. to harden the shellac. The lap and glass dust will soon cut away the coat which intervenes between the lap and job, but it will remain on all the surfaces not directly attacked and protect them from the glass dust which would adhere, and by the action of the fingers in handling soon depolish it. A further object in coating with lac is that it actually produces more perfect angles. As soon as both sides of the shank from *b* to *b* are ground perfectly flat, the flat face of the part extending from *a* to *b* can be lapped, letting the face of the lap be applied as shown at the dotted line *f*, the outer edge of the lap coming to *a*. This part, from *a* to *b*, can be cut through as shown in any ornamental device desired as it is only intended in the lapping to produce a perfectly flat face with a mirror like polish. The greatest difficulty in grinding and polishing this part is to press it perfectly flat and evenly on the lap. This can be accomplished by cementing with shellac or lathe wax two little discs of metal on the inside of the ring as indicated by the pointed piece of peg-wood *n*. The size and shape are indicated at *i* and the hole in the middle is to keep the point of the peg-wood *n* in position while the grinding is going on. The manner of doing this is to hold the ring in position with the thumb and finger of the left hand while the right hand holds the peg-wood pressed against the ring, keeping the face of *a b* perfectly flat on the lap *D*. After the surfaces are all ground flat wash the ring in soap and water and dry it with a soft towel; then go over it with the bread crumb to ensure the removal of all particles of fine glass. Now, change the lap, putting in the one on which you are to use the diamantine and (watch) oil. It is well to grind the diamantine as directed for the glass. The finest grade of diamantine should be used. If your work shows any scratches and does not come up perfect there is some fault in the material used or in the manner in which the process has been conducted. The reader on the first experiment may not produce perfect work but he will be satisfied he can soon conquer all the difficulties; and so he will if he perseveres.

#### Buying Wedding Rings.

A SHY YOUNG man went into a Broadway jeweler's store, so says a local reporter, and looked at gentlemen's rings, fingering them and asking questions about them, and yet appearing to take only a forced interest in them. The jeweler's clerk whispered



to a bystander, "By-and-by he will come around to the wedding or engagement rings. That is what he has come after." Sure enough the young man presently pointed to a tray of flat gold band rings. "What are they for?" he inquired. The clerk said that they were merely fancy rings, worn by ladies and gentlemen, and that some folks bought them for wedding rings. The shy young man tried two or three on his little finger, and, finding one that would not quite go over his knuckle, said, "Give me this one. How much is it?"

"It's five dollars," said the clerk, "but if you want a wedding ring I would advise you not to buy it. Every now and then we sell them to people who insist upon having them, but as soon as they find out the fashion they come back and have them melted up and rolled up into this old-fashioned round form. The only wedding ring is the round ring, plain and simple."

"Gimme a round one, then; same size as this."

He got one and went away. The clerk laughed, and said he could tell when a young man wanted a wedding or engagement ring every time; though sometimes they ask to be shown clocks, bracelets, or anything rather than what they come for. Very many come right to the point, though they stammer and falter about it quite painfully. Others again ask frankly and boldly to see what they want. "There never has been a change in the fashion of wedding rings," said the clerk; "the plain round gold ring has always been the only correct thing. Men sometimes choose other kinds, but women never make that mistake."

"Do women choose their own wedding rings?"

"Oh, very often. Frequently they come in alone, fit a ring to the right finger and leave it for the prospective bridegroom to pay for. Sometimes they pay for it and take it away, and of course the young man reimburses them. Quite often, too, the brides come in with their mothers. Very serious and grave the mothers are, and show neither timidity nor sentiment. They ask for wedding rings, they look them over, buy one, and go away. Irish and German girls often bring their lovers as well as their mothers. There is not a funnier sight in the world than to see a clumsy fellow hanging behind and looking unutterably foolish while his sweetheart and her mother discuss the purchase. They pay no attention to him until they come to the final selection. Then they tell him how much is to be paid, and he pays it and they all go out. Irishmen are apt to be close buyers. They will scarcely ever buy anything without knocking something off the price, but no Irishman ever haggles over a wedding or engagement ring. It does not matter if the wedding ring he chooses comes as high as nine dollars. He pays the price without a murmur."

"Many foreigners, particularly Germans, exchange wedding rings. The bride pays for the groom's ring and vice versa. At the altar they exchange rings. They come in together to buy them."

"What is the fashion in engagement rings?"

"Oh, there is no fashion in them particularly. Any pretty ring set with small stones does for the purpose. Turquoises and pearls are popular just now, and so are pearls by themselves. Diamonds are the rage with people who can afford them, and from that the precious stones range downward in price to amethysts. Engagement rings cost from \$15 to \$150; wedding rings from \$5 to \$15. Very many persons have initials, dates or mottoes engraved in their wedding rings. 'Mizpah,' or 'Thine forever' are favorites, but the commonest custom is to have merely the initials and date—'J. S. to S. J., Nov. 11, 1883,'—cut in the inner surface of the ring. Nothing is engraved in engagement rings. The manner of wearing them has changed, however. They used to be worn on the index finger of the left hand, you know, but the ladies think that a little too much of an advertisement nowadays, and they wear them on the third finger of the right hand. That finger of the left hand is still the one on which wedding rings are worn."

## Microscopes.

PROF. E. THEERY says in *Journal Suisse d'Horlogerie*, that the construction of the microscope, like that of the spy-glass, is based on the property possessed by glasses with spherical surfaces of causing the luminous rays emanating from a far-off source to converge in one point called the focus. These glasses or lenses constitute the simplest microscope—the magnifying glass—the properties of which were, doubtless, not unknown to the ancients. If they did not actually employ lenses, they probably replaced them by glass balls filled with water, for the delicate tracery of certain objects of art, particularly Greek engraved stones, indicates the use of a means of increasing the power of sight.

In the thirteenth century Italian artists aimed at producing concave and convex glasses, and their use soon became general; but it was not until about 1600, in Galileo's time, that the spectacle makers of Middelburg, in endeavoring to combine concave and convex glasses, constructed the first compound microscope. Since that time, they have undergone numerous modifications. First the concave glass was replaced by a convex lens which gave a considerable augmentation; next, composite eye-pieces were formed, and, finally, about 1823, Ch. Chevallier combined the first achromatic microscopes with several lenses, such as are constructed to-day in all countries.

Microscopes may be divided into two groups according to their construction and use, the simple microscope or magnifying glass and the composite microscope. The magnifying glass or bi-convex lens is still much used in industry. It is the most convenient for simple enlarging, for it has over the composite microscope the advantage of showing the objects in their natural position, the latter presenting them reversed. But, should a stronger magnifying power become necessary, grave defects are noticeable in these simple glasses. These defects, known under the name of aberration of sphericity and refrangibility, cause the objects observed to appear misshapen, the central part alone being clear, and the sides indistinct and fringed with colors. As a remedy for this Wollaston endeavored to combine several lenses acting as a single one for enlarging; but as each of the curves were slighter, the range of observation was considerably diminished. These composite magnifying glasses or doublets gave a stronger magnifying power. Thus, naturalists constantly employ in dissecting, doublets, which give amplifications from thirty to sixty, while with a single glass they rarely exceed ten or twelve. If, however, we wish further to increase the power of the doublet, we come upon a disadvantage which renders it almost valueless. The greater the power the lesser the distance of the first glass from the object, so that for an increase of say sixty times, this distance is only about two or three millimeters.

The compound microscope differs essentially from the magnifying glass, as, instead of seeing the object directly through a lens, it is seen by means of a magnifier, the eye-piece, already amplified by a first lens, or, better, by a series of lenses constituting the object glass. The image observed by the eye-piece is reversed, which matters little when observing preparations made beforehand, but it is very troublesome when it is necessary to manipulate the objects observed.

For the purposes of naturalists the microscope has become an instrument of the highest precision and very expensive. The quality of the glass, both as to material and workmanship, has been the chief aim of constructors, for on that depends the value of the instrument. If the image formed by the object glass is imperfect, it can never be rectified by the eye-piece, whatever be its power. Microscopic objects are usually transparent, or rendered so thin as to become so, the light diminishing as their thickness augments. The strongest possible light is therefore necessary. To that end a mirror is placed beneath the object as a reflector; but if the object be opaque it is lighted up by means of a magnifier, termed a condenser. But another point in connection with the microscope is its position with regard to the object. In observing with a magnifying

glass, every one knows there is a fixed distance at which the object is best seen. It is the same with the microscope, and this distance being lesser and more vigorous, the movement requires to be very delicate and very precise. When adjustment by the hand or with a rack and pinion does not suffice, very fine micrometric screws are used, which gradually displace the object glass until a proper distance is arrived at.

If we now leave the instruments constructed for researches into natural history and consider the kind of instrument necessary for manufacturers, we find that it must fulfil the following conditions: As simple as possible, combined with solidity; at a moderate price; easy of working, particularly as to placing in position; permit not only of viewing the objects, but of marking the exact forms. We may, therefore, suppress with advantage the complications arising from excessive magnifying power, the microscopic screw, and the system of lighting by transparency, which may be replaced by a simple mirror. As to amplifying power it is quite useless in industry to exceed eighty times. The strongest enlargements will practically be only fifty to sixty, and they can be obtained with a single object glass and two eye-pieces of different powers. When it is necessary to mark perfectly determined forms like those of the teeth of pitchings, the various parts of an escapement, or the line of a screw-thread, the sight, even when aided by the microscope, does not suffice. It is requisite to produce faithfully by drawing what is seen, and compare it with what the article should be. For this purpose there is adapted to the microscope a small apparatus called a clear chamber, which allows the image of the object to be thrown on a piece of paper and its contour traced with a pencil. By this means an exact and enlarged form of a small article may be reproduced to verify proportions with the compass as with an article of larger dimensions. The microscope is not only an instrument of observation, it is likewise the most precise of measuring tools. In the measuring tools in use there is always a mechanical amplification which proves a source of error, either from the force employed or from the inevitable imperfections of execution. The enlargement furnished by the microscope does not necessitate the use of force, nor flexion of pieces and consequent errors. To employ the microscope for this purpose it is sufficient to stretch a very fine thread across the interior, or two threads crosswise, exactly at the point where the image of the object is formed amplified by the objective. In this way the eye, seeing this image through the eye-piece, sees the thread also which appears to be on the object itself, and serves also as an exact reference mark. Instead of this thread a micrometer may also be placed in the microscope; that is to say, a piece of glass divided in five parts, the values of which are determined by experience. By noting how much of these divisions the object occupies its dimensions can be determined? The applications of the microscope are very numerous in the field of scientific observation, and it is capable of rendering as important services in the industries of precision. If this instrument has not yet ranked as a usual tool in horology, it may be foreseen that soon it will become as indispensable to the conscientious workman as the simple magnifying glass is to-day.

---

### Electro-Fire Gilding and Silvering.

COMPLAINTS AGAINST the durability of the ordinary electro-gilding and silvering by contact or limited battery, and of the abrasion when exposed to wind and weather or friction, as compared to the good old fire gilding, are very frequent, although the former is generally acknowledged to have a richer appearance than the latter. The reason for the complaints are based upon the fact that the deposits of the precious metals by the galvano-electric system are not of a solid and compact nature.

Experience has taught that electro-gilt ornaments attached to churchyard monuments, lightning conductors, crosses, balls, eagles,

etc., and other emblems of church steeples and public buildings, very soon tarnish, which is fully proved to be the cause of the unsolid and porous deposit of the gold on the metal forming the base of the articles.

To effect good substantial deposits of gold or silver by electricity, we are compelled to take recourse to batteries of great capacity, dynamo-electric apparatus worked by steam power, arrangements which to purchase and maintain entail expenses prohibitory to the jeweler or watchmaker who conducts his business on a limited scale, and who, if even in a position to purchase and maintain these expensive appliances, in very rare instances has sufficient work to realize a profit to warrant and encourage the outlay.

In order to overcome the instability of the deposit by electro-gilding, and to avoid the considerable expense of costly apparatus, while securing at the same time a good deposit by electricity, the following procedure is recommended as practically good and satisfactorily effective:

To the ordinary gold solution for electro-gilding add some mercury previously dissolved in nitric acid; this solution, diluted with water and neutralized of the acid by adding small quantities of spirits of ammonia until immersed litmus paper does not change its blue color into red. Previously to dissolving the mercury in the acid, it is necessary to free it from the lead with which commercial mercury is generally contaminated, and this is effected simply by pressing the mercury through a piece of wash-leather, which will allow the mercury to pass through on squeezing it, and retain the lead.

This prepared gold solution will be a mercurial gold amalgam of a fluid or watery nature, and should not be mixed in larger quantities than required for immediate use. The articles to be gilt are immersed in this solution appended to the wire in connection with the cathode (zinc) of any battery, and will receive a gold deposit of quicksilver appearance after the article has remained a sufficient time in the solution. It is then withdrawn, rinsed in water and laid on a fresh fire made of small pieces of charcoal until the mercury has evaporated, which takes place very soon, as the quantity of mercury is very small in proportion to the gold deposit, although the color of the former predominates. After the evaporation of the mercury, the article has all the characteristics in color and toughness of fire-gilding, pale yellow and dead surface. The article is then scratch-brushed in beer and will assume a fine luster. If a strong deposit of gold is required the operation may be repeated after each scratch-brushing. By weighing the article before the first immersion into the gold solution and again after the last scratch-brushing, the weight of the gold deposited can very accurately be ascertained. In the last evaporation the article is left for about half a minute or so longer on the fire than necessary for driving off the mercury, which will deepen the color of the gilding.

After a final scratch-brushing, the article may be gilded in an ordinary gold solution *without* the addition of mercury, by which the richness of color of electro-gilding and the durability of fire gilding are combined.

This kind of gilding is accomplished with much less trouble, and, what is of great importance, attended with less or almost no danger than fire-gilding on the old method, which requires the continual handling of a large quantity of mercury so injurious to health, as the deposit of mercury in combination with the gold deposit in electro fire-gilding is so slight as to evaporate almost instantaneously, and affords the great advantage of a regular deposit of gold, not only on the surface but in the hollows and interstices of the article to be gilt. If any places or portions of the articles do not require gilding, they may be kept from being thus treated by a coating of copal varnish mixed with a little rouge powder and drying in a warm place before immersion in the gold solution.

The same method may be advantageously applied to electro fire-silvering, by employing silver solutions, and the results are excellent.

Care must be taken that the mercurial gold or silver solutions are kept carefully apart from the ordinary gold and silver solution.

Silvering by fire has been very much neglected and preference given to electro-plating, but fire gilding is still practiced to a considerable extent, and the careful perusal of the above cannot fail to convince us that the combination of electro fire-gilding not only fully replaces the ordinary and antiquated process of fire-gilding, but effects at the same time a great saving of precious metal, which would unavoidably be lost in fire-gilding, while at the same time presenting all the advantages to be derived from that method.—[H. BUSCH, Hull.

### A Few Defects of the Duplex Escapement.

ONE OF the chief causes of the duplex stopping is its holes getting wide. This rapid wear is caused by having so heavy a balance. It is therefore essential that all the escapement holes should be of real rubies. When the balas or spinel ruby is used, the holes will soon be found to become elongated, which soon throws the escapement out of order; for there is no escapement which requires greater care with the size of holes and pivots than the one under treatment. When taking the watch down, let the first thing you examine be its staff holes. If you consider that they are worn at all large, carefully notice by holding the balance with the forefinger so that you see just the place the balance moves round to for each tooth. When this has been done, press the balance so that both pivots are nearer the scape wheel; if the hole is at all oblong and you first get the pivots at one side, then at the other, you will soon see the difference in the degree of vibration of the balance in the two different positions. If there is sufficient difference for the impulse roller to go too deep into the scape wheel—that is, if it catches the back of the impulse tooth in its return journey—then the best remedy will be to put in a new hole, unless the old hole is spread out round with diamond dust then a new pivot has to be made to fit. Of course, the new hole would be the quickest and best method providing you have the proper size hole on hand. Any hole may be opened with the diamond dust if properly beaten into a thin piece of copper wire, and it is advisable to keep these things on hand ready for use; there are cases when it can be done quicker than to unhang a wheel in order to turn a pivot to fit a hole.

The next thing the repairer should notice that all the impulse teeth act correctly on the impulse pallet. Sometimes a portion of the teeth will be found to be worn so that they do not give the pallet sufficient lift; when this is the case and if matters are not too far wrong, it can be remedied by moving the impulse roller round a little on the staff, whereby it approaches nearer to the slot in the ruby roller. This will give it a little more drop and is generally effective. Sometimes the roller depthing is altogether too shallow, and it is well in this case to leave the drop in its original place; carefully top the locking teeth, and see also that they are rounded up in their original position; then the cock and potance may be gently tapped a little nearer to the scape wheel; or if the foot pins are perfectly tight then the holes may be slightly opened, a little obliquely, with the broach handle towards the scape wheel; then bend the foot pins a little backward so that they slant and fit into the oblique holes. Where this is done you will have obtained the desired effect, since it moves the jewel holes in such a manner that the escapement is nearer, and with a little practice the job really causes not much trouble. In doing this, it is well to correct both ends—both cock and potance. If only one end is done, it naturally throws the balance a little out of upright, which will put the escapement wrong in another respect; for if there is much end shake to the staff the escapement might be right in one position but wrong in another. In any case we cannot be too careful in nicely adjusting the end shake; for where this is excessive with both scape wheel and balance, then we may find that the impulse pallet is very likely to either slip

over the top of impulse teeth, or else ride the plane of the wheel; and yet, with the least move of the wearer the watch may go on all right again. Even this simple fault has, in some cases, been a great annoyance to both wearer and repairer, and it is perhaps the simplicity of the complaint which has given it more of a chance to get overlooked, for there are times when we look for great things and miss the little ones.

### Graduating Marks on Glasses.

THE ORDINARY method of grinding in the graduating marks on glasses, glass scales and gauges, etc., by means of a copper wheel in a lathe, is too well known to demand an elucidation; an etching fluid for effecting the same purpose has lately been introduced in commerce that may be used with an ordinary steel pen for writing on glass; it is a very practical fluid and easily used for the purpose, but it is very dear and many of our readers would perhaps like to ascertain its ingredients and manner of compounding them.

Dr. Max Müller, of the chemico-technical laboratory of Brunswick, specifies the following *modus operandi* for the compounding of this glass-etching fluid, which may be applied to glass with a common steel pen while leaving deeply roughened strokes.

Equal parts of bi-fluoride of ammonium (*Fluorwasserstoff-Fluorammonium*) and dried precipitated baryta sulphate are triturated in a porcelain mortar. The intimate mixture is in a platinum, lead or gutta percha dish repeatedly treated with fuming hydrofluoric acid, until after diligent stirring (best done with a thin, pistil-like gutta-percha rod), the rod only leaves very quickly disappearing impressions. The thus obtained thickish paste can at once be used with an ordinary steel pen for tracing upon glass, the etching ensues at once, and is of a very handsome dull-gray appearance of such an intensity that the etching is visible at a proportionately great distance. It suffices to permit the fluid to operate only for about 15 seconds upon the glass—a longer time might under circumstances even be hurtful, since the edges of the strokes lose in sharpness. By the use of a smaller quantity of fluoride of ammonium, and also if hydrofluoric acid of a less concentration is employed, more lustrous etchings are obtained, especially in the latter case the edges will remain sharp even by a prolonged duration of the operation, although the legibility of the writing is impaired thereby.

The quality of the baryta sulphate is of great importance in the composition of a good etching fluid. It must be precipitated from a baryta salt solution by an excess of sulphuric acid, very thoroughly washed by decantation, filtered and dried at about 120° C. It is possible only in this case to divide it sufficiently intimate.

It is barely worth mentioning that the etching fluid cannot be stored in glass bottles, gutta-percha receptacles are to be employed for this purpose, with a neck that can be closed with a cork saturated either with wax or paraffine. The thickening medium, the sulphate of baryta, naturally settles quickly, due to its specific gravity; it is necessary, therefore, to thoroughly shake the fluid before using. This is easily affected by dropping a few grains of shot into it; it is well known that they, being lead, are neither attacked by the fluid nor deteriorate it by their presence, while they effect a rapid and thorough intermixing of the constituents. Small gutta-percha flasks or bottles are the best for keeping the fluid. This may, however, be also kept in glass bottles if they have been coated with a thin layer of wax inside. For this purpose, heat the bottle over an alcohol flame, drop a small piece of wax into it and constantly rotate the bottle while the molten wax is cooling and adhering to the sides. Also fuming hydrofluoric acid may be kept unaltered for a long time in such a prepared bottle.

Writing having been performed upon the desired object with this fluid, rinse it in water and dry with a cloth. Since hydrofluoric acid, when coming into contact for a length of time with the skin, is liable to produce painful, and, under certain conditions, even

malignant inflammations and ulcers, it is indispensable to observe great caution in the use of the fluid.

The etchings produced with this fluid are so rough that if a piece of metal is rubbed upon a place some of it will adhere with its peculiar color and luster. If, for instance, a signature written with the fluid upon a bottle is rubbed with a small piece of brass (a strong brass wire is best), the signature will appear to be handsomely gilt. If, next, the metal is protected with a coat of some colorless lacquer, a brilliant and durable label has been produced.

### Clock Trains.

*Continued from Page 392.*

*Second Problem.*—To find the number of teeth of a movement, when the balance makes 16,800 vibrations in one hour, or in the time that the center wheel makes one revolution, if the scape wheel has 14 teeth.

For one revolution of the scape wheel the balance makes 28 vibrations, and during 16,800 vibrations the scape wheel makes 16,800 : 28 = 600 revolutions. It becomes now necessary to find the number of teeth of a train consisting of three wheels, in which, during one revolution of the first wheel, the last pinion which carries the fourth or the scape wheel makes 600 revolutions.

If 3 pinions, each of 8 leaves are used, then, according to the above given rules, the following factors will be found: 2, 2, 2, 2, 2, 2, 2, 2, 2, 2, 3, 5, 5. These may be separated into the following portions:  $5 \times 2 \times 2 \times 2 \times 2 = 80$ ;  $2 \times 2 \times 2 \times 2 \times 2 = 64$ ;  $5 \times 3 \times 2 \times 2 = 60$ —numbers very appropriate in a watch train.

*Third Problem.*—To find the number of teeth of a movement in which the fourth wheel makes one revolution per minute, and in which the balance makes 18,000 vibrations per hour, or during one revolution of the center wheel.

Since the fourth wheel is to make one revolution per minute, its velocity will be 60 times as great as that of the center wheel, because this makes only one revolution in 60 minutes, consequently, the balance will make 18,000 : 60 = or 300 vibrations per minute. If the scape wheel has 15 teeth, it will make one revolution during 30 vibrations, or 600 revolutions in one hour, consequently 600 : 60 in one minute, or in the time during which the fourth wheel makes one revolution; it is necessary to first calculate the number of teeth of the fourth wheel so that the balance makes 300 vibrations while the former makes one, or that the scape wheel makes 600 : 60 = 10 revolutions per minute; again, it is necessary to find the number of teeth of the center wheel or that of the third wheel, so that the fourth wheel pinion makes 60 revolutions while the center wheel makes one.

Since the scape wheel makes 10 revolutions during one of the fourth wheel, it is clear that this must have 10 times as many teeth as the scape pinion has leaves, and since a pinion of 8 leaves has been used, the fourth wheel must have  $8 \times 10$  or 80 teeth.

To find the number of teeth of the other two wheels, it is necessary to first ascertain the number of the pinion leaves, which we will establish at 12 and 10, and we will obtain for the center wheel 90 and for the fourth wheel 80 teeth. If the pinion had 8 leaves, we would obtain 64 and 60, which we illustrate by the following example:

$$\begin{array}{l} 90 : 12 = 7\frac{1}{2}. \\ 80 : 10 = 8. \\ \text{and } 8 \times 7\frac{1}{2} = 60. \\ 64 : 8 = 8. \\ 60 : 8 = 7\frac{1}{2}. \\ \text{and } 8 \times 7\frac{1}{2} = 60. \end{array}$$

PINIONS.

The engagement of the wheels and pinions of a watch require the greatest exactness; with badly constructed depthings the motive

power does not operate uniformly upon the regulator, and the watch varies; the different parts of a watch are quickly worn off, because a watch, the pinions of which form no good depthing, requires an unduly great motive power to overcome the injurious influence of the frictions, and to restore the loss of power occasioned by the defective depthings.

Depthings may be faulty either by reason of the diameter of the pinions compared to that of the wheels, or by too shallow an engagement of the wheel teeth with the pinion leaves, or by the shape of the wheel teeth and pinion leaves.

1. If the diameter of the pinions stand in no correct proportion to that of the wheels, the leaves and wheels will brace against each other, or a blow would be caused in the depthing, and in both cases a loss of power and inequality will be provoked in the depthing.

2. If the depthing is either too deep or too shallow, a blow or irregularity and lameness will be caused, and beside this a loss of power and inequality occasioned in the depthing.

3. If the teeth and leaves are badly formed, the rate cannot be uniform, and the regulator would receive irregular impulses.

It is, therefore, very essential to make the radius of the pinions entirely proportional to that of the wheels, to well determine the point of engagement of these parts, and to make the teeth of pinions of such a shape that they are enabled to perform the depthing as gently and uniformly as possible.

*The size of pinions.*—The diameter or radius of a pinion is proportioned to that of the wheel, as the number of pinion leaves to that of the wheel teeth. (We have reference to the pitch radius, as will be seen further on). If, therefore, a wheel of 50 teeth and 20 lines diameter seizes into a pinion of 10 leaves, then the diameter of the pinion must be 4 lines, because

$$50 : 10 = \frac{20 \times 10}{50} = 4.$$

The size or diameter of pinions, however, varies somewhat according to the number of wheel teeth, as will be seen afterward; means are easily found in practice to determine these sizes.

The following rules to determine the sizes of pinions are generally adhered to:

A pinion of 16 leaves must have a diameter, which, if used for measuring, would embrace 6 full wheel teeth.

One of 15 leaves would embrace a trifle less than 6 full teeth, or, to be exact, 5 full teeth and the point of the 6th.

One of 14 leaves must span 6 teeth over their points.

One of 12 leaves must embrace 4 teeth and the point of the 5th, or, what is the same, embrace  $4\frac{1}{2}$  teeth.

One of 10 leaves must embrace 4 full teeth.

One of 8 leaves must embrace 4 teeth over the points less the one-fourth part of a tooth space; for pendulum clocks 4 teeth over the points.

A pinion of 7 leaves must be a little less than 3 full teeth; for pendulum clocks 3 full teeth and the one-fourth of a tooth space.

A pinion of 6 leaves must span 3 teeth over their points; for pendulum clocks 3 full teeth.

When the wheels are driven by pinions, these latter must have a somewhat larger diameter.

#### THE FRICTION OF THE TRAIN PIVOTS.

It is very important to reduce the friction of the wheel pivots to a minimum quantity, and to make it constant so that the motive power be transmitted with the greatest attainable regularity to the regulator, which is necessary to enable the latter to maintain its arc of oscillation of the same magnitude. The friction of the pivots is due to the pressure of the motive power and the weight of the wheels. The wheel work nearest to the motive power must have strong pivots, so that they possess sufficient resistance, and neither wear the pivot holes nor make them wide, by which the friction would be increased and at the same time alter the true point of engagement. In tenor with the distance of the wheels from the motive power, the

diameters of their pivots must decrease, because these latter sustain less pressure and are of a greater velocity than the first parts, and since it is necessary to almost annihilate friction, which otherwise would absorb the power necessary for maintaining the motion of the regulator.

The pivots must be hard, round and well polished; their shoulders flat, not too large, with ends well rounded off so that they do not attack the piece which bears them. The holes must be round, smooth and not larger than is requisite for the free motion of the pivot, which is surrounded with oil. Their sides must be parallel to those of the pivot so that they sustain the pressure of the pivot equally at all points of their length. The holes, of brass or gold, must have been hammered sufficiently that their pores are closed in such a manner to prevent too quick a wear. It is well if the oil sinks are of a size that they retain a sufficient quantity, that it does not dry out too soon and does not thicken by mixing with the worn-off particles of the metal. The underturning of the pinion leaves are conical, but so that the thicker part be nearer to the pivots, because by this disposition the oil is retained at the pivot by attraction, and does not seek to spread into the pinion leaves, as is often the case, especially with flat watches in which this provision is slighted.

[THE END.]

## Proceedings of the Horological Club.

### A DISTINGUISHED BODY OF WATCH AND CLOCK MAKERS.

*One hundred and sixteenth discussion.—Communicated by the Secretary.*

[NOTICE.—Correspondents should write all letters intended for the Club separate from any other business matters, and headed "Secretary of the Horological Club." Direct the envelope to D. H. Hopkinson, Esq. Write only on one side of the paper, state the points briefly, mail as early as possible, as it must be received here not later than the eighth day of the month, in order to be discussed and reported in the CIRCULAR for the next month.]

ELECTRO MOTORS FOR WATCHMAKERS.—STONES FOR WATCH JEWELS.  
—POLISHING JEWEL SETTINGS.—ABOUT THE BOTCHES.

#### *Secretary of Horological Club:*

Will some one of your honorable body give an article in THE CIRCULAR on an electro-motor to drive a show stand to sit in the window, and would there be any injurious effect arise from such a machine to watches hanging on the wall in a glass case a number of feet away?

2d. Where can I obtain the rough garnet or crysolite to make jewels of?

I find in looking over the back numbers of THE CIRCULAR a question how to polish jewel settings to American watches. The way I finish them with good results, on brass or gold, is to first turn the setting down to the right thickness or nearly so, then grind down to a gray on a ground glass slab with rotten-stone and oil, and then clean off the oily rotten-stone and polish on a boxwood lap with diamantine and oil which gives a nice gloss. It will also give a nice black gloss on steel, only use oilstone to gray steel with instead of rotten-stone. The operator should be particular to clean off all of the graying powder in each case, before using the boxwood lap, and be sure to keep the lap in a place free from grit or dust when not in use; brass watch wheels can be finished in the same way as the jewel settings by the same process.

Now for the botches that we see and read so much about. My plan is to secure legislation in the matter by having a law similar to the druggists in this State, which appoints a commission to examine the druggist, and, if qualified, to give him a diploma. Otherwise he cannot deal in drugs and dispense the same. If the watchmakers could get such a law that would appoint a commission of competent workmen to examine every workman, and, if competent to do all kinds of work, grant a diploma, and, if not, oblige them to post themselves sufficiently to get one or quit the business or not to engage in it, I am of the opinion it would be productive of good results. I know it has done so in the other trade. At some future time I will make some other suggestions as to methods of doing work. From an old subscriber to THE CIRCULAR. C. H. L.

Mr. Electrode replied that he believed there was only one satisfactory electro-motor of small size now in the market—that made by the Electro-Dynamic Motor Co. Such machines were used for running sewing machines and other light machinery, also for dentist's drilling and similar purposes. They were well spoken of for such uses, but he doubted whether they would be very desirable for watchmakers. Their strong magnets would without doubt be very dangerous to have near a lot of watches, even several feet away. Moreover, the speed of such motors is always very high—probably very much too rapid for the use to which our correspondent proposes to put them. Of course, it might be speeded down by belting or gearing, but that would hardly pay. It would be too much like keeping a steam engine to run a clock with. The care of the batteries, also, requires the attention of some one who knows at least a little about such things. Altogether, he was of the opinion that our correspondent would do better by getting up some sort of gearing driver by a weight or spring, and governed by a fan wheel like the striking part of a clock.

The rough garnets and crysolites could be obtained from some one of the lapidaries or watch and chronometer jewelers who advertise in THE CIRCULAR. Or any good watch material house would obtain them for him.

Watch jewel settings can be faced up as described, but the beauty of the other method is that, with a properly finished graver, both the faces and the slopes can be polished in the same way—each with a single stroke of the graver. We shall be pleased to hear from Mr. L. as proposed, and also from any others of our readers who have superior or new ways of doing work or of doing it more quickly or easily than is usually done, or new tools, small fixings, attachments, etc.

INGOLD FRAISES.

#### *Secretary of Horological Club:*

In reading an article in the February, March and April Nos. for 1883, of THE CIRCULAR, on watch repairing (by Herman Sievert), he speaks of an Ingold fraise tool, which he claims is more useful to a watch repairer than a Swiss rounding up tool, and advises anyone intending to purchase a rounding tool to get an Ingold fraise. Could you give me a description of said tool, or give me address of some watch-tool firm where I would likely be able to get a cut and description of it? I have always used the Swiss rounding tool. Please state about what price they are. R. H. C.

Mr. McFuzee explained that the Ingold fraise is a cutter in the form of a pinion, the leaves of which are so cut longitudinally as to act like files and abrade the teeth against which they rub. A fraise must be selected which has the same tooth spaces as the wheel whose teeth are to be dressed up, and the same pitch diameter as the pinion which hooks into it. It is then arranged in a depthing tool, with the wheel, and by means of a bow is revolved in gear with the wheel until the teeth are properly rounded up. It will be seen that every different proportion and size of wheel and pinion will require a different fraise to suit it, so that a complete assortment, for all the needs of a watch repairer, might require some hundreds of the fraises. A set comprising 100 pieces may be bought for about \$60. They would probably have to be imported from France, for I know of no dealer in this country who keeps them in stock.

It should also be remembered that they do not *cut* the teeth of the wheel nor round them. This should be done, at least roughly or approximately, by the cutting engine or the rounding-up tool. The fraise is then used to give the final finish to the shape of the teeth, which it will do if properly selected and used, better than any other tool. But owing to the great number needed in order to be prepared for all contingencies, they are rather expensive unless one's work runs principally to certain definite sizes of wheels. If the teeth are to be made thinner at the flanks, that should be attended to before the fraises are used, as they act only on the *addenda* or rounded ends of the teeth, not on the flanks.

## IMPROVEMENT IN CLOCKS.—TROUBLESOME STOP WORKS.

*Secretary of Horological Club:*

I wish in your next proceedings you would call the attention of all our American clockmakers to the fact that they would and could make their clocks very much more desirable and valuable by attention to one small point, viz., the putting of the escape wheel cock on like that of watches, in the place of 2 rivets, for very many reasons apparent to all. It will be a very small expense and trouble, and would enable watchmakers to take the cock off and repair the hole as nice as new, and enable us to put the escape wheel in nice order, etc., etc. Further comment, I think, is unnecessary, for I have found the American clockmakers very clever and ready to adopt a good thing.

A fine E. Howard watch came into my hands this week to be put in order, which I did. I put it up and found it ran a few minutes and had a good motion, and there it would stop. It was all in good order—that I knew, for I had tested every part. I carefully took it down and found a burr had been formed on the under side by a strain on the stop works. This was *very, very small*, and the male one was the troublesome one; the female was still free. I refinished it and then it was all beautiful. I mention this thinking some one else may have trouble of the same kind. They are an elegant watch, of good material and sound and elegant workmanship. I can say the same for all of the Howard watches and clocks that I have ever seen, and they are many.

W. F. A. W.

## INVISIBLE MOVEMENT FOR WINDOW CLOCK.

*Secretary of Horological Club:*

I wish to place a dial on plate glass window to show time from the street. What would you recommend? I would like an invisible movement. Can you give me a description of something that will do?

C. D. H.

Mr. Horologer replied that there were several ways of doing this. One was to arrange on a smooth round arbor a minute and an hour hand, so balanced that a very slight change of weight in the short end would cause them to revolve and take up a new position of equilibrium. The change of weight is produced by concealing in the bulb on the short end of the hand, a watch movement which had in place of hands a heavy lead weight, carried around by the minute arbor or by the hour wheel as the case might be. The movement which was in the hour hand of the clock carried a weight on its hour wheel which made one revolution in 12 hours, and by its change of position caused the clock hand to seek its equilibrium in corresponding positions, thus showing the hours on the clock dial apparently without any cause. The minute hand was in the same way revolved once each hour. Another way was to fasten the hour and minute hands on plates of glass, which could be acted upon at their edges where it would not be noticed, and so move the hands with them. Invisible levers of glass wire sometimes used to act upon ratchets on the hands as connected with them. As the lever is transparent, its presence is hardly likely to be detected. Many other ways are known but the foregoing would be sufficient to show the direction in which Mr. H. should work to attain the object he had in view.

## THE PROPER THING FOR ENGAGEMENT RING.

*Secretary of Horological Club:*

I would like to know what the style for an engagement ring is now, and what finger it is to be worn on? I understand it is a plain band. Hoping to hear from you soon, I remain,

F. B. C.

Mr. Clerkenwell said that a diamond solitaire is now the orthodox engagement ring, worn on the usual finger. For those not able to sport diamonds, a plain band or any neat simple ring will do.

## POOR MOTION OF WATCH BALANCE.

*Secretary of Horological Club:*

What is the cause of loss of motion of balance wheel especially in American watches, and how would you restore the lost motion?

INQUIRER.

Mr. Uhrmacher said the inquiry was a good deal like asking what is the cause of poor health, and how to cure it. The cause may be any one out of a thousand different things. It would be impossible to give a satisfactory reply to this in the limits allowed for the report of our discussions. "Inquirer" should read the "Practical Hints on Watch

Repairing," by "Excelsior," published in THE CIRCULAR from 1876 to 1880, where he would find the most complete, painstaking and practical series of articles relating to this subject in the English language. He will be surprised to learn how many defects in the train, the escapement, the jewels, the balance, the hair spring and many other parts may cause the loss of motion in the balance—but in every case he will find a plain and practical remedy stated in language which every intelligent workman could understand. THE CIRCULAR is also filled with many other useful articles, and a careful study of them will aid him to detect the cause of the difficulty in each particular instance and to apply the remedy suited to it. A definite reply to so comprehensive a question is impossible. We might enumerate a few faults, but they might have nothing to do with the watches which "Inquirer" had to repair, so we cannot do better than to refer him, as we have, to the best and most available sources of information on these points.

## STAIB'S STREET WATCH SIGN.

*Secretary of Horological Club:*

With this I send you the wood cut of the large street timepiece—the large gold open face stemwinder of which you give full description in the number 11, month December, page 371. You will find the wood cut just like the photograph.

ADOLPH STAIB.

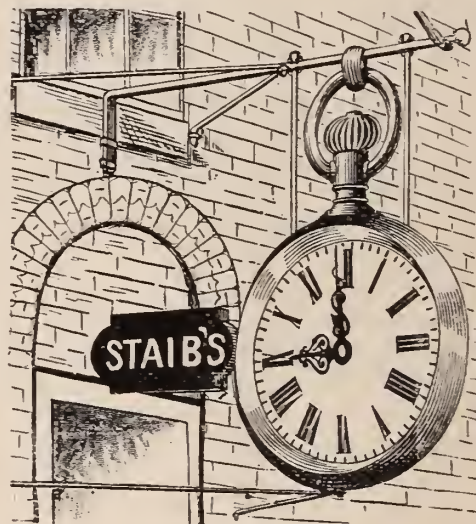

Mr. Clerkenwell hoped that Mr. S. would at an early day give us a full description of how the hands of the sign were operated from the shop. He thought that it would do Mr. S. no harm to explain his method, as many of our readers would doubtless study it out for themselves, and it would be better to give the whole trade the benefit of it, if it was really practicable and useful. If he wished to secure it for himself he could apply for a patent, and then he would run no risk by publishing it, but might derive some income from it by selling rights to use at a reasonable figure.

## BENZINE FOR CLEANING WATCHES.

*Secretary of Horological Club:*

Your article of January, on the subject of "Benzine," was of more value to me than the cost of THE CIRCULAR for 6 years, and I am now satisfied you did not tell it all. Benzine, the longer it is kept from the first, no matter how pure it is, will soon become poor and good for nothing. I was most woefully taken in by it for once. I found some when I was in the city that was very nice, so I procured enough to last me a year or more some 6 months ago. Well, a few weeks ago a customer came back with his watch which I had repaired 10 days before, and asked if I cleaned his watch; said it stopped every cold night. I was surprised. I went for the Kellogg's oil I was using, and had been for years. I sent for the best oil that could be had. It came forthwith, and it was Kelly's. For a week or so watches began to come back, still with the same old story. I had about concluded to give up the business. But on getting the January CIRCULAR, and from that and what I knew of benzine, my eyes came wide open. I dumped my benzine out of the back door and have gone back to alcohol again and am happy. I think benzine is like beer, the best when new.

I write this that you may warn others to look out, lest they too may have trouble as I had.

J. W. S.

Mr. Horologer said that benzine should be kept in glass-stoppered bottles, or the more volatile parts will rapidly evaporate, leaving only the portions of greater specific gravity, and which are of less value for dissolving grease, etc. If the benzine was also impure, the benzine proper might entirely disappear, leaving nothing in the bottle but the impurities. Good benzine has its place as stated in our January discussion, but, for the general uses of watchmakers, alcohol was preferable, except for cleaning parts which were cemented with shellac, as, for instance, the ruby pin, pallet pearls and the like. They should not be cleaned with alcohol, as it would dissolve the shellac and loosen the jewels. These should either be cleaned with pure benzine specially prepared for watchmakers' use, or else with the old ways by elder pith, the brush, etc.

DEMAGNETIZING STEEL, ETC.

Secretary of Horological Club:

I saw in THE CIRCULAR some time ago, an article on demagnetization. Now, I am not an electrician, but not having seen anything in your columns in regard to a simple way of reducing magnetism, I will give you my experience. Possibly the matter has been referred to before, and I have overlooked it.

Take a common horse-shoe magnet, and magnetize a piece of steel or a bar, if you wish, and hold the bar in front of the magnet, as near as possible without touching, reversing the poles by turning the piece of steel as quickly as possible back and forth several times, receding as you invert, and you will find the magnetism entirely gone from the bar of steel.

J. C. R.

Mr. Electrode said that about the same method was described in THE CIRCULAR about the end of 1879 and beginning of 1880, only it was applied to removing the demagnetism of watches, by the process of oscillating the watch before the magnet and at the same time gradually moving it away, as described by Mr. R. for the steel bar. The trouble is that the process is very long and tedious, and the magnetism is seldom entirely removed by it. Mathey Bros. & Mathez have a machine which does all this automatically and much more perfectly and rapidly than can be done by hand. Their process was so successful that they now had magnetized watches sent to them from all parts of the country for treatment. A new process has been devised in the Physical Laboratory of Harvard College, which consisted in following the converse of the foregoing method. Instead of magnetizing the watch very rapidly in opposite ways and gradually diminishing the degree of magnetism till it became practically null, they very strongly magnetize the watch by a powerful alternating current passed through a suitable coil or electro-magnet, then gradually let the current diminish in strength till it becomes null. The result is practically the same in each case, although, theoretically, the latter would seem preferable. He believed, however, that no complaints were made against the former on the score of completeness.

THE RECORDING REGULATOR.

Secretary of Horological Club:

Will you kindly bring before the Club for examination, my new invention of a recording regulator, an attachment to a common regulating hand for the purpose of recording its action and position from time to time. The trouble hitherto has been that when a customer comes in to have his watch "touched up a little," that the watchmaker (who has regulated hundreds, perhaps, since he last saw this one), is unable to remember the least particular concerning the watch or its peculiarities. The customer, of course, does not, and, therefore, the regulator is moved by guess, and at random. The sample which we send you is fitted with the recorder, which, as you can see, is extremely simple, consisting merely of a small segment or pin passed through a hole or bearing in the regulator, and held by friction to the index gauge. The recorder or segment is moved so as to lie directly under the regulating hand. When said hand is now moved, either right or left (fast or slow), the recorder remains in its place. You will readily see that an accurate record is here made, for it records:

1st. "Where the regulator stood before being moved," which is sometimes very useful in case it is moved too far, so that it can be replaced and moved again.

2d. How much it was moved, which records the comparative amount of the variation for which it was regulated.

3d. Whether it was moved "fast or slow"—which records the tendency of the watch to gain or loose time.

It will be seen that here is a guide as well as a recording regulator, which will enable anyone qualified to judge more accurately the amount or extent of the next move, and thus expedite the regulating of a watch, which ordinarily is such a "wild goose chase" with the *geese* decidedly in the advance. In other words, a watch can with this attachment be accurately regulated in two or three moves, which is not only a saving of time but reflects more credit on the watch, its maker or repairer. This improvement is patented.

A. C. CLAUSEN.

Mr. Rubypin exhibited the movement fitted with the regulator as described, so that the hand remained still while the regulator was moved, thus showing where the regulator was before it was moved, being a very simple and effectual way of keeping track of the changes made.

[Copyright Secured.]

Letters to Watchmakers.

[By DR. LEONARD WALDO, Astronomer in charge of the Horological Bureau of the Yale College Observatory.]

II.

OBSERVATORY WATCH RATE CERTIFICATES.

LET US now examine in detail a class I. certificate issued by the Yale observatory, in order to arrive at a clear understanding of the steps employed, and the significance of the final report. Here is one taken from the books of the observatory, and bearing the date of February 12th, 1884. The full record, read from the reverse side of the certificate is as follows:

RECORD.

| DATE.          | Daily Rate. | Variation. | Temperature, Far. | Remarks.        |
|----------------|-------------|------------|-------------------|-----------------|
| 1883. Dec. 30. | +0.4        | S          | 59°               | Pendant up.     |
| 31.            | +1.1        | -0.7       | 59                | " "             |
| 1884. Jan. 1.  | +0.9        | +0.2       | 59                | " "             |
| 2.             | +0.8        | +0.1       | 59                | " "             |
| 3.             | +0.9        | -0.1       | 57                | " "             |
| 4.             | +0.3        | +0.6       | 57                | " "             |
| 5.             | +0.4        | -0.1       | 56                | " "             |
| 6.             | -2.6        |            | 54                | Pendant right.  |
| 7.             | -3.1        | -0.5       | 54                | " "             |
| 8.             | -1.4        |            | 55                | Pendant left.   |
| 9.             | -1.0        | -0.4       | 57                | " "             |
| 10.            | -2.5        |            | 58                | Dial down.      |
| 11.            | -2.6        | +0.1       | 58                | " "             |
| 12.            | -0.7        |            | 57                | Dial up.        |
| 13.            | -1.2        | +0.5       | 56                | " "             |
| 14.            | -0.4        | -0.8       | 56                | " "             |
| 15.            | -0.4        | 0.0        | 57                | " "             |
| 16.            | -0.7        | +0.3       | 58                | " "             |
| 17.            | +0.4        | -1.1       | 58                | " "             |
| 18.            | +0.4        | 0.0        | 57                | " "             |
| 19.            | 0.0         | +0.4       | 57                | " "             |
| 20.            | -0.2        | +0.2       | 56                | " "             |
| 21.            | -0.4        | +0.2       | 55                | " "             |
| 22.            | -3.3        |            | 33                | Refrigerator, " |
| 23.            | +2.0        |            | 87                | Oven, "         |
| 23.            | 0.0         |            | 54                | " "             |
| 25.            | -0.2        | +0.2       | 54                | " "             |
| 26.            | -1.7        | +1.5       | 57                | " "             |
| 27.            | -0.5        | -1.2       | 58                | " "             |
| 28.            | -0.4        | -0.1       | 59                | " "             |
| 29.            | 0.0         | -0.4       | 59                | " "             |
| 30.            | -0.3        | +0.3       | 59                | " "             |
| 31.            | +0.2        | -0.5       | 62                | " "             |
| Feb. 1.        | +0.5        | -0.3       | 64                | " "             |
| 2.             | 0.0         | +0.5       | 62                | " "             |
| 3.             | +0.2        |            | 62                | Pendant up.     |
| 4.             | +0.3        | -0.6       | 62                | " "             |
| 5.             | +0.4        | -0.1       | 62                | " "             |
| 6.             | +0.3        | +0.1       | 63                | " "             |
| 7.             | +0.8        | -0.5       | 63                | " "             |
| 8.             | +1.0        | -0.2       | 63                | " "             |
| 9.             | +0.2        | +0.8       | 63                | " "             |

From the front page of the certificate, we take the following results, which are derived from the record already given:

RESULTS.

|  |       |
|--|-------|
|  | S     |
| Mean daily rate.....                                   | -0.29 |
| Mean variation.....                                    | ±0.41 |
| Variation for 1° Far.....                              | +0.10 |
| Difference before and after oven and refrigerator..... | -0.08 |
| Difference between pendant up and dial up.....         | +0.85 |
| Difference between pendant up and pendant right.....   | +3.42 |
| Difference between pendant up and pendant left.....    | +1.77 |
| Difference between dial up and dial down.....          | +2.27 |
| Difference between first and last week.....            | +0.22 |
| Difference between the extremes of rate... ..          | 5.3   |

It will now be our object to show how these results are derived from the record, and then to explain the relative importance assigned to the various adjustments for daily variation of rate, position and temperature. The first column of the above record gives the date on which the day ended for which the daily rate is given in the second column. The daily rate has been computed from the comparisons of the watch with the clock, allowing for the error of the latter, and taking the precautions explained in the first letter. The daily rate is all that we need concern ourselves with, since the actual error of the watch has nothing to do with its excellence as a time-keeper. The sign + means gaining, and the sign - means losing throughout the record. The third column is obtained by subtracting the daily rate on the line on which a "variation" is written, from the daily rate on the line immediately above. Thus, +1<sup>s</sup>.1, daily rate for Dec. 31st, subtracted from +0<sup>s</sup>.4, daily rate for Dec. 30th, gives us -0<sup>s</sup>.7 as the variation of the daily rate between the two days ending respectively, Dec. 30th, and Dec. 31st. The fourth column gives the mean temperature of the watch for the date ending in the same line. The last column gives the position in which the watch was placed for its trial during the dates in the first column. In the third column the variations are not given in the days that changes of position occurred. The variations of rate are only considered when the watch is in the same position. So also the variation for temperature is not entered in the variation column.

We can now summarize the record as follows:

SUMMARY OF RECORD.

| 1             | 2         | 3                   | 4          | 5                   | 6   |
|---------------|-----------|---------------------|------------|---------------------|---|
| Position.     | No. Days. | Sums of Rates.      | Mean rate. | Adopted Rate.       | Difference between mean adopted rate & adopted rate |
| Pendant up.   | 7         | S<br>+4.8           | S<br>+0.68 | S<br>+0.57          | S<br>1.83   |
| "    right.   | 2         | -5.7                | -2.85      | -2.85               | 1.59  |
| "    left.    | 2         | -2.4                | -1.20      | -1.20               | .06   |
| Dial down.    | 2         | -5.1                | -2.55      | -2.55               | .98   |
| "    up.      | 10        | -3.2                | -0.32      | -0.28               | 1.29  |
| Hot and Cold. | 2         | -1.3                |            |                     |   |
| Dial up.      | 10        | -2.4                | -0.24      |                     |   |
| Pendant up.   | 7         | -3.2                | +0.46      |                     |   |
| Sums,         | 42        | -12.1               |            | -6.31               | 5.75  |
| Mean,         |           | -0 <sup>s</sup> .29 |            | -1 <sup>s</sup> .26 | 1 <sup>s</sup> .15                                  |

The first column of the summary corresponds to the last column of the record. The second column of the summary corresponds to the first column of the record, and in the third column of the summary are found the separate sums of rates corresponding to the position and rates of the last and first columns of the record. Thus for "pendant up" we have the seven days between Dec. 30th and Jan. 5th, and the sum of rates = +0<sup>s</sup>.4 +1<sup>s</sup>.1 +0<sup>s</sup>.9 +0<sup>s</sup>.8 +0<sup>s</sup>.9 +0<sup>s</sup>.3 +0<sup>s</sup>.4 = +4<sup>s</sup>.8. Now, if we divide this +4<sup>s</sup>.8 by the number of days, 7, we obtain the mean rate of +0<sup>s</sup>.68 shown in column 4. The numbers given in the succeeding lines in the columns 3 and 4 we obtained in a precisely similar manner. The mean rate for the hot and cold box of course is not given. Since the watch occupies some of the positions more than once during its trial, it is necessary to take into account all its rates in the same position. The fifth col-

umn, therefore, contains the rate for a given position computed from all its ratings in that position. Thus we find that the adopted rate for the position pendant up is the mean of the rate +0<sup>s</sup>.68 at the beginning of its trial, and the rate +0<sup>s</sup>.46 at the close, at which times the watch is pendant up. So, too, the rate dial up is taken as the mean of the rates -0<sup>s</sup>.32 and -0<sup>s</sup>.24 = -0<sup>s</sup>.28.

We can now derive the results—thus the sum of the rates in the third column of the summary is -12<sup>s</sup>.1, and the number of days is 42. Dividing the former number by the latter we have -0<sup>s</sup>.29 as the mean daily rate. From the third column of the record by adding up the variations without regard to sign we find the sum to be 13<sup>s</sup>.6, and the number of days on which variations are counted to be 33. Dividing again the former number by the latter we find the mean variation to be ±0<sup>s</sup>.41. Here the double sign is used to show that the watch is liable to vary its rate in either a gaining or losing direction by this amount. We see from the record that its rate at 87° F. is +2<sup>s</sup>.0, and that at 33° F. its rate is -3<sup>s</sup>.3. From this it appears that a change of +54° of temperature caused a change of rate of +5<sup>s</sup>.3; therefore dividing the latter number by the former, we have the variation for 1° F. to be +0<sup>s</sup>.10. Consulting the summary we see that the rate dial up before the hot and cold tests is -0<sup>s</sup>.32. After the hot and cold tests the rate dial up is -0<sup>s</sup>.24. Subtracting the latter number from the former we obtain for the difference before and after oven and refrigerator -0<sup>s</sup>.08.

In column 5 of the summary the adopted rates for pendant right and left, subtracted from the adopted rate pendant up give us +0<sup>s</sup>.85 and +3<sup>s</sup>.42 as the difference between pendant up and dial up, and as the difference between pendant up and pendant right respectively. The adopted rate for dial down is -2<sup>s</sup>.55. The adopted rate for dial up -0<sup>s</sup>.28. Subtracting the former from the latter we find the difference between dial up and dial down to be +2<sup>s</sup>.27. The rate pendant up during the first week was +0.68. The rate pendant up the last week was +0.46; subtracting the latter from the former we find the difference between the first and last week to be +0<sup>s</sup>.22.

Examining the record we find that the greatest losing rate, -3<sup>s</sup>.3, occurred January 22d in the refrigerator, and the greatest gaining rate, +2<sup>s</sup>.0 occurred January 23d in the oven. We find, therefore, for the difference between the extremes of rate, 5<sup>s</sup>.3. Let us now endeavor to determine some arbitrary criterion by which this watch may be compared with other watches having different results. In other words let us affix a mark to it which shall be based upon all the tests to which it has been subjected. In establishing this criterion it is altogether a matter of judgment as to the relative importance to be assigned to the staying qualities of the watch, or its excellence in reproducing its daily rate as shown by its daily variation, and of the adjustment for position, and of the adjustment for compensation and temperature.

We have adopted the arbitrary convention that the capacity of a watch to run with a uniform rate in the same position is of equal importance with the regular adjustment for different positions.

We have considered that the adjustment to heat and cold is of one-half the importance of either of the other two. Marking on a scale of 100, an absolutely perfect watch would receive a mark of 40 for having no variation of its daily rate, 40 more for having no variation in different positions, and 20 for having no variation in temperature. The sum of these three marks would be 100. Having established the highest mark to be given and the lowest mark being zero, the mark actually given is made to depend upon the limit set for excluding a watch from a certificate.

The limit for daily variation being 2<sup>s</sup>.00 and the total mark being 40, each single mark corresponds to a change of  $\frac{2}{40} = 0.05$ , and we have the formula

$$\frac{2.00 - \text{the mean daily variation}}{0.05} =$$

the mark for daily variation. Again, the limit for position variation being 10<sup>s</sup>.00, and the total mark being 40, each single mark corresponds to a change of  $\frac{10}{40} = 0.25$ , and we have the formula



$$\frac{10^{\circ} - \text{mean position variation}}{0^{\circ}.25} =$$

the mark for position variation. Again, the limit for temperature compensation being  $0^{\circ}.30$  for  $1^{\circ}$  F., and the total mark being 20, each single mark corresponds to  $0^{\circ}.015$ , and we have the formula

$$\frac{0^{\circ}.30 - \text{variation for } 1^{\circ} \text{ Far.}}{0^{\circ}.015} =$$

the mark for temperature compensation.

Let us apply these formulæ to the computation of a mark for the watch we have been so far considering. The mean daily variation being  $0^{\circ}.40$ , we have the mark for variation

$$= \frac{2^{\circ}.00 - 0^{\circ}.41}{0^{\circ}.05} = 31.8.$$

Returning to column 5 of the summary we find that the mean adopted rate in the five positions is  $-1^{\circ}.26$ . If now we take the difference between this mean and the adopted rates in the different positions we shall get in the sixth column the variations from the mean adopted rate caused by putting the watch in its different positions.

The sum of these variations in the watch in question is  $5^{\circ}.75$  and the mean of the five positions is, therefore,  $1^{\circ}.15$ . This is the number which is called mean position in the second variation formula. We have, therefore, for the mark for position,

$$\frac{10^{\circ}.00 - 1^{\circ}.15}{0^{\circ}.25} = 35.4.$$

We have already found the variation for  $1^{\circ}$  F. to be  $0^{\circ}.10$ . Substituting this number in the third formula we have the mark for temperature =

$$\frac{0^{\circ}.30 - 0^{\circ}.10}{0^{\circ}.015} = 13.3.$$

And we have for the total mark  $31.8 + 35.4 + 13.3 = 80.5$ , or, neglecting the decimal, 81.

The above complete example of a first-class rating is given because of the number of inquiries as to the exact process used in making up the annual reports issued from the observatory. This year's report, which will be published in June, will have its watches computed as above. The subject is seriously considered of establishing the watch tests on the altogether different basis of running a watch for five day periods in the five positions, and in heat and cold five days each.

There is no doubt that a better determination of the position variations would be had by running the watches longer than we do with pendant right and left and dial down. For this reason we have advocated an international scheme of watch rating, each position to receive the same number of days. What the effect of five days at  $35^{\circ}$  F. followed by five days at  $65^{\circ}$  F. which is again followed by five days at  $95^{\circ}$  F., would be on the oil and balance of a watch, we should be glad to hear from experienced watch adjusters.

In my next letter I shall describe the proposed scheme in detail, and our methods of subjecting watches to temperature and position tests.

LEONARD WALDO.

### Peculiarities of Precious Stones.

DESCRIPTION OF SOME CURIOUS DIAMONDS, READ BEFORE THE NEW YORK ACADEMY OF SCIENCE, BY GEORGE F. KUNZ.

AT THE International Exposition held at Amsterdam during the summer of 1883, was exhibited a suite of wonderful round diamonds that, for their size and merit, were awarded the prize for "round bort." They were purchased by a New York firm who offered them to Messrs. Tiffany & Co., and on examination were found as follows: The specimens being four in number and all as round as a marble; they were of Brazilian origin and in this form

can be used for drilling purposes to equally good advantage with the black amorphous carbonade, as the intricate twining or compounding destroys the easy clearance property that renders ordinary crystals unfit for this purpose.

No. 1, the largest diamond, is entirely round, of a light vitreous brown color and translucent, its entire surface being covered with small re-entering angles, giving it the appearance of the fibrous or rather bunched crystals of acicular rutile, variety nigrine, from Magnet Cove, Ark. These markings, numbering hundreds, are over the entire surface, and render it very evident that the crystal is the result of a multiplicity of twinings of cubic crystals as is often the case with iron pyrite. It is 17 mm. in diameter, weighs 8.542 gr.,  $41\frac{3}{4}$  kts.; specific gravity is 3.51954+.

No. 2 is entirely round, of a milky-gray color and translucent. To the eye the surface appears quite smooth, but under the glass the same markings show on a smaller scale as in the large diamond, though the surface is duller. It is 10 mm. in diameter, weighs 2.0815 gr.,  $10\frac{3}{8}$  kts.; specific gravity is 3.522+.

No. 3 is almost entirely round, of a milky translucent white, no crystalline markings being visible, and has a fused vitreous appearance as if it had been round with small pit-markings, and then the entire mass fused obliterating the pitting. It is 9 mm. in diameter, weighs 1.289 gr.,  $6\frac{3}{8}$  kts.; specific gravity is 3.5218.

No. 4, the weight of which was 1.478 gr., and its specific gravity 3.649, proved on examination not to be a diamond, but a red hematite sphere that had been rolled, and was evidently a pseudomorph after limonite or some other like mineral, or was filled with air cavities (see low specific gravity). Not coming into ownership of it I could only try the surface, whereas if it could have been broken more definite results might have been arrived at. It seems very remarkable, however, that this specimen, having been viewed by the majority of the Amsterdam diamond dealers, examined by the judges and experts, and then passed through the hands of several old and experienced importers of diamonds, should have deceived them all. Even a diamond cutter after being informed of the fact, doubted it until he had tried the stone on the wheel where he was instantly convinced, so perfect was its color and luster.

My attention was called by Mr. A. Ludecke, of this city, to a curious diamond, now in the possession of Messrs. Tiffany & Co., weighing  $6\frac{1}{8} - \frac{1}{8}$  karats, the original weight of which was  $10\frac{1}{2}$  karats, 4 karats having been lost in cutting. The diamond has 18 facets, of which 4 of the top and the table are white, and 4 are a distinct black; on the back 4 facets are white, and the other 4 and the culet are black. The stone was found to be excessively hard, much above the average of hardness in fact, and although apparently poorly cut the cutter had sustained a loss, owing both to the longer time required in the work and also to the fact that he was remunerated at a certain rate per karat. This diamond is of Brazilian origin and was originally in octahedron. When found the entire stone was a jet black, and it was cut with the intention of producing a black stone. After the table had been put on one of the points, and the four edges of the octahedron had been removed to make four facets, it was found that the black color was only a superficial coating, and that the inside of the crystal was entirely white with the exception of an occasional carbon inclusion. It shows no more play of color than a black stone, but gives very decided brilliant metallic reflections. The curious effect of five white and four black reflections, and the appearance of a clearly defined Greek cross in black outline when viewed by transmitted light makes, the stone a remarkable freak of nature, and not a little interest is added to it by the fact that its strange features were so well developed by mere accident.

Among curiously marked diamonds may be also mentioned the two presented to the Jardin des Plantes by Mons. Halphen and described by Mons. Descloizeaux. (See Poggendorff's *Areol*, 1849, p. 447). These stones are colorless and round, and a distinct three-leaved clover in black occupies the entire dimension in each stone.

Another similar stone in the Duke of Leuchtenberg's cabinet, now in the Bavarian State Cabinet at Munich, has three leaves united by a circle. All these three are of Indian origin.

In addition to the many curious inclusions in sapphire described by Sir David Brewster (see Trans. Royal Society Edinburgh, 1823), and Dr. Isaac Lea (see Proceedings Acad. Nat. Sciences, Feb. and May, 1869), and others. I desire to mention a ruby from Siam weighing over 1 karat and quite flat, which was brought to my attention for examination by the owner, who, doubting that the stone was a ruby, from its almost brown garnet red color, supposed it might be a spinel. It proved a ruby, however, and in the back of the gem near the culet, a small spot about one millimeter in size attracted my notice. On examining this with a microscope I found it to be a perfectly formed octahedral crystal of ruby spinel that was evidently either included at the time the sapphire was formed or else formed simultaneously with it, making in this case what might truly be called a ruby-spinel.

Another curious gem is a crystal of diamond belonging to Mr. H. Fera, in form is a distorted octahedron. The cleaver, when he had taken off one plate, found to his astonishment that it enclosed a perfect octahedral crystal of diamond. The size of the outer crystal is 11 mm. in diameter. The upper four faces of the inner crystal project above the surface, and the loose piece fits over it perfectly with its cap-like hollow.

Another is a white topaz pebble from Minas Novas, Brazil, presented to the writer by Mr. J. D. Yerrington. From this two cleavages have been removed, leaving its size 13 mm. by 9 mm. by 8 mm. In addition to the numerous fluid cavities it contains, it is penetrated by a fine olive-green colored, four-sided, doubly-terminated crystal of diopside, 6 mm. long and 5 mm. wide, and this in turn includes some black substances.

The specimens of beryl and crypt colored emeralds I exhibit this evening were sent to me by Mr. J. A. D. Stephenson, Statesville, N. C., the most earnest and successful collector of the minerals of that State, who has also done more to call the attention of the outside public to North Carolina minerals than any other local collector. He was also the first to call the attention of mineralogists to the beryls and spodumene (emerald, W. E. Hidden, *Am. Jour. Science*, III., series xxii., 489, 1881); (hiddenite, J. L. Smith, *Am. Jour. Science*, III., series xxi., 128, 1881), and also in many other localities. In a letter he states:

"These emeralds occur on the property of Mr. J. O. Lackey, about one mile southwest of the Emerald & Hiddenite Co.'s property, Stony Point, N. C., a short distance from the Lyons property (Smeatons), and are found in a vein of black decomposed mica associated with quartz crystals, common rutile and hiddenite. I consider the locality a promising one, although there has been but very little work done as yet."

The lot sent me consists of 33 crystals, 10 centimeters to 50 centimeters long (2 inches), and 1 centimeter to 5 centimeters wide, in color varying from colorless to a light emerald green, and nearly all have the curious saw markings in considerable number on each corner of the prism, and some contain simple crystals of rutile. The interest attaching to these crystals is in the fact that they are found at some distance from the Emerald & Hiddenite Co.'s property, and that between these we have the Lyons property on which Mr. Smeaton found the same minerals, showing that the deposit is not an accidental one, and that there is encouragement for future work in this section of the State.

### The Deluge.

THE FLOODS in the Ohio river and its tributaries have, during the past month, exceeded anything ever known, and the devastation wrought by the overflowing waters and the distress consequent thereon has been terrible. At Cincinnati the water attained a depth of over seventy feet, inundating business houses and isolating

the occupants of many dwellings, who could only be reached by boats. A score or more of other places along the river were also submerged beneath the water, and their occupants left in the greatest distress. Notwithstanding her own heavy losses, the benevolent men of Cincinnati organized promptly a relief committee to convey aid and succor to the sufferers in her neighboring cities and villages. Mr. John C. Dueber, president of the Dueber Watch Case Manufacturing Company, was active in this good work, and among other things sent the following dispatch to this city:

Feb. 11, 1884.

The calamity that has befallen this city is terrible, and the worst is yet to come. We appeal to the generosity of the jewelers of the United States for aid for the homeless and hungry. Contributions sent to us will be distributed amongst the most deserving sufferers, and receipt duly acknowledged. Show this to all jewelers.

THE DUEBER WATCH CASE MFG. CO.,

John C. Dueber, *Pres.*

Steps were at once taken to secure contributions from the trade in this city, and in the course of a few hours the following reply was sent:

Feb. 13, 1884.

TO DUEBER WATCH CASE MFG. CO., *Newport, Ky.*

I send this day by Adams Express, one thousand dollars in currency, subscribed by the trade of this city for relief of sufferers from floods. More to follow.

D. H. HOPKINSON,

42 Nassau St., New York.

Further calls upon the trade increased the contributions to the sum of \$1,830, which was duly forwarded and its receipt acknowledged. The following is a list of the names of the contributors to the relief fund:

|                                 |          |                                 |    |
|---------------------------------|----------|---------------------------------|----|
| Oppenheimer Bros. & Veith.....  | \$100    | John Wilson's Sons .....        | 25 |
| D. & M. Bruhl.....              | 100      | Middleton & Bro.....            | 25 |
| Marx & Weis.....                | 25       | Stern & Stern.....              | 25 |
| Keller & Untermeyer.....        | 25       | D. & M. Weil.....               | 20 |
| Stern Bros. & Co.....           | 25       | Wm. S. Hedges & Co.....         | 25 |
| Louis Herzog & Co.....          | 25       | Sussfeld, Lorsch & Nordlinger.. | 25 |
| Hirsh Brothers.....             | 25       | Carter, Sloan & Co.....         | 25 |
| E. Aug. Neresheimer & Co.....   | 25       | A. Wallach's Nephews.....       | 25 |
| L. & M. Kahn & Co.....          | 25       | Cash M.....                     | 10 |
| F. W. Gesswein.....             | 25       | Falkenau, Oppenheimer & Co...   | 25 |
| Henry May.....                  | 25       | J. Eugene Robert.....           | 25 |
| Smith & Knapp.....              | 25       | Grinberg, Goodman & Pollack..   | 25 |
| Alfred H. Smith & Co.....       | 25       | Leopold Weil & Co.....          | 25 |
| Randel, Baremore & Billings...  | 50       | Seth E. Thomas.....             | 25 |
| Henry Ginnel & Co.....          | 25       | J. B. Bowden & Co.....          | 25 |
| Albert Lorsch.....              | 25       | Cash E.....                     | 10 |
| Henle Bros.....                 | 25       | Lissauer & Sondheim.....        | 25 |
| L. H. Keller & Co.....          | 25       | J. T. Scott & Co.....           | 25 |
| Pforzheimer, Keller & Co.....   | 25       | Louis Strassburger & Co.....    | 25 |
| Courvoisier Wilcox Mfg. Co...   | 25       | Levy, Dreyfus & Co.....         | 15 |
| Max Freund & Co.....            | 25       | Champanois & Co.....            | 25 |
| Spencer Optical Mfg. Co.....    | 25       | Julien Gallet & Co.....         | 25 |
| Robbins & Appleton .....        | 100      | L. Hammel & Co.....             | 25 |
| Dominick & Haff.....            | 25       | D. H. Wickham & Co.....         | 25 |
| Thomas G. Brown & Sons.....     | 25       | Wm. Smith & Co.....             | 25 |
| Charles Glatz.....              | 25       | Saxton, Smith & Co.....         | 25 |
| Lyon & Hardy.....               | 25       | Ladd Watch Case Co.....         | 25 |
| The Brooklyn Watch Case Co...   | 100      | Albert Berger & Co.....         | 25 |
| Enos Richardson & Co.....       | 25       | G. & S. Owen & Co.....          | 25 |
| Miller Bros.....                | 25       | Mathey Bros. & Mathez.....      | 25 |
| D. H. Hopkinson, Jewelers' Cir. | 25       | L. Lelong & Bro.....            | 25 |
| Total.....                      | \$1,830. |                                 |    |

The terrible suffering consequent upon the flood have been graphically described by the daily press, but they can never be fully realized except by those who witnessed them. The money contributed to the relief of the sufferers has been judiciously expended by committees of well-known citizens. In addition to the amount contributed by the trade as shown in the above list, quite a number of houses contributed through other sources, so that the total sum contributed by the trade of this city is highly creditable to its members, and fully sustains their reputation for liberality in times of suffering and want.

A recent telegram from Mr. Dueber acknowledges the receipt by the Cincinnati Jewelers' Relief Fund of \$7,674.34 from all sources, including the contributions above specified. One hundred dollars was forwarded by the Relief Committee to the leading jewelers in the following named places: Lawrenceburg, Ironton, Ripley, Parkersburg, Wheeling, Maysville and Portsmouth, in addition to which between five and six hundred persons were fed daily in Cincinnati.

## Sight.

WHAT THE OPTICIAN SHOULD KNOW ABOUT OPTICS.

Based upon an extensive hospital experience in Austria, Germany, England and New York. By C. A. BUCKLIN, M. D., New York. Author of Detection and Correction of Visual Imperfections, Cause and Cure of Cross Eyes, Effects of Color on Distance, and Monograph on Astigmatism.

*Continued from page 24.*

*Cataract.*—It is the duty of every person who takes upon himself the responsibility of deciding what lenses individuals should wear, to have an intelligent idea of the nature and treatment of cataract. If a man is blind who comes under your observation you should be able to advise him whether his case is curable or not, and by plainly describing to him the nature of his trouble prevent him from being imposed upon by every unprincipled vender of salves and lotions.

The *practical* solution of this problem is very simple. If the individual has complained of seeing a variety of black specks before his eyes—he is now blind and you see deep in the center of the pupil a little round white spot—you are sure he has cataract. If the eye is not red and never has been painful these are favorable points. If there is no discharge of pus from the tear passages when the finger is firmly pressed just below the inner corner of the eye, this is another very favorable circumstance. If his cataract is uncomplicated he should be able to see light when a candle is placed twenty feet from him in a dark room. He should be able to see it when held above, below, to the right and to the left of each eye, testing them separately while one is closed or covered.

By the method I describe later, the cataract will be sufficiently "ripe" for removal when the person with either eye can no longer count figures which are held against a dark coat at a greater distance than two feet, the *back* of the blind person being turned toward the bright light of the windows.

Thus, *any* person blind can have sight restored at once if eye is not red or painful, round white spot is *deep* in pupil, cornea looks clear, can see the light from a candle at twenty feet with either eye, seeing it when held *above, below*, to the right and the left of each eye, and the *greatest* distance they can count fingers is two feet. Persons who cannot distinguish light are incurable.

Persons who are so blind that they cannot follow their calling but who can still count fingers at several feet can have their cataracts ripened artificially by several operative methods in from one to six weeks.

Having considered the practical points necessary to know that one may decide whether a man blind from cataract is curable or not, we will consider the nature of cataract and the best way to deal with it.

Just behind and in contact with the portion of iris forming the pupil there is situated a convex lens; it is constructed in *layers* resembling very much the structure of an onion. This lens, which should be perfectly clear, is sometimes clouded because of faulty development, or from disease it becomes cloudy occasionally in young persons, but usually cataract is a disease of old age. Cataract always means opacity of this lens. It never can be cured without removing the lens either by absorption or extraction. Persons under twenty who have cataract can have it cured by absorption; the pupil is widely dilated with sulphate of atropia, and the anterior capsule of the lens is cautiously opened with a sharp needle from time to time. The contact of the aqueous fluid with the substance of the lens causes it to absorb; this method is only applicable to young persons, and is especially applicable to children having congenital cataract.

White spots seen deep in the pupils of children's eyes are usually *congenital* cataracts; if they are not they are a growth known as "glioma," which is in reality a species of cancer. If it is cataract the sooner it is removed the better the vision of the child will be. If it is "glioma" the eye must be promptly removed, or the disease traveling back through the optic nerve will enter the brain and produce death.

The cataract of old age is the one which comes most frequently under our observation. Through the kindness of Hutchinson, Bowman, Cooper and Wells, of the Royal Eye Infirmary of London, *Bader* of Guy's Hospital, *Liebrich* of St. Thomas' Hospital, *Mooren* of Düsseldorf, *Horner* of Zürich, *Arll*, *Stillwag* and *Mauthner* of Vienna. Also Doctors *Agnew*, *Knapp*, *Noyes*, *Webster* and *Grünig* of this city, I have had the opportunity of seeing them operate frequently, and of hearing them freely state what their experience had taught them. I am grateful to each of these gentlemen for their frankness in telling me what their experience had been.

The information gained from them combined with my personal experience gained from fifty-six successful cataract extractions, and a careful study of the causes of failure in each unfortunate case I ever observed, has forced me to adopt some fixed and positive rules to follow in the removal of cataract.

Eight out of every ten accidents I ever saw during the extractions of cataracts were due to the fact that the person was not under ether, vomited severely from the effects of the ether, or it being given improperly or in too small a quantity the person was not brought to a stage of complete muscular relaxation.

The operation which I always employ is to hold the lids back with a spring speculum, and, after fixing the eye with a light fixation forceps, I make an opening by puncturing the globe just outside of the corneal margin, at the point where the upper third joins the middle third of the cornea. The knife is pushed carefully to the opposite side of the globe and punctures from within outward, at a point corresponding to the point of entrance. From this point you cut slowly upward till you have cut your way out, coming out in the corneal margin, or just outside of it. The section having been completed, a pair of *fine* forceps are carefully introduced through the wound, the iris is grasped, pulled through the wound and cut clear from its entire length, thus preventing it from becoming bruised during the delivery of the lens, and also preventing the iris from protruding through the wound and becoming fast in it.

A *sharp* cutting instrument is next introduced through the wound, and the capsule is carefully cut in the line of the wound, great care being taken not to cut beyond the margins of the lens into the suspensory ligament. Gentle pressure upon the lower margin of the cornea will now cause the lens to appear through the wound.

The first accident which happens from the want of proper etherization is the person strains; the lens is pushed forward carrying the iris before it; the iris falls over the knife and is cut; the eye fills with blood; in attempting to remove the iris we fail, because we cannot see through the blood in the eye; in attempting to grasp the iris the capsule of the lense is wounded, and the lens forces its way out, making an irregular opening through the capsule, the flaps of which may be caught in the wound and produce bad consequences.

Should the lens not escape, and we attempt to open the capsule without seeing distinctly, we are very liable to open the vitreous chamber; frequently the straining of the person will cause the vitreous to escape as soon as the first cut is completed, and in our confused attempts to get the lens out it is lost and falls into the globe of the eye, destroying this eye in a few days, and the other through sympathy in a few months.

The lens may be extracted, but, in doing so, so much injury is done to the eye that it is destroyed through the inflammation which results from the rough manner in which the eye has been manipulated.

The manner in general use in Europe of opening the capsule is to make a **└**-shaped cut in the capsule. This method necessitates that the cataract being *very* ripe, otherwise the debris which remains behind, as well as the internal surface of the flaps of the capsule, which are always in an acute state of proliferation, come in contact with the iris and inflame it, frequently causing the pupil to close entirely by plastic exudation.

The reactions which follow cataract extraction on the continent, which are considered mild, would be considered by us severe.

It will be seen that the opening that we make in the capsule leaves it a closed pocket, with its internal rough surface excluded from any possible contact with the iris. Also, all the debris remaining after the extraction of the lens remains enclosed in this sack.

The usual amount of reaction, which formerly followed nearly every cataract extraction, has, by this method, been so completely avoided that I no longer hesitate to operate upon persons a long distance from me.

To avoid the accidents which I have seen, I insist that the person shall not eat anything for ten hours before giving the ether.

The cone from which the ether is given should be large enough to hold at least one quart of ether vapor, the air should be excluded as completely as possible, and the ether cone should be sufficiently stiff not to collapse as the patient exhausts the air and ether vapor it contains.

During the first few minutes of the patient's consciousness you should *push* the ether, as he will then breathe well. By thus pushing the ether rapidly as possible you avoid, to a great degree, its sickening effect, and also all the effects which may be considered dangerous. The patient is not ready for the operation till muscular relaxation is complete. Any one who is tempted to operate before the stage of excitement is past will be very likely to meet with accident.

This is more dangerous than to operate without ether.

The *muscular* rigidity having been overcome, the iris is no longer pressed forward against the knife. I use in addition to this precaution to avoid wounding the iris the sulphate of eserine in the eye before the operation. This contracts the pupil down to a very small point, keeps the iris completely out of the way, and also makes it retract back from the wound much better, and the hemorrhage into the eye is less. With proper etherization, and a contracted iris giving support to the lens, I do not think any careful operator will have any accident or difficulty in removing cataract successfully.

It is a very instructive fact that eight out of ten accidents which occur in competent hands are caused by a lack of proper attention to the subject of etherization.

It is true that you may operate on ten eyes without ether and be perfectly successful, and the very next time you operate you may lose two eyes for the same patient, because you did not use it. I therefore do not agree with most operators that the patient may choose as to whether the operation may be done with or without ether.

Everyone who has mechanical dexterity, and will follow carefully certain necessary rules, well established by experience, will have success in the removal of cataract.

Failures in cataract operations are due to infection or blunders.

Depressing the cataract from the pupil with a flat needle always ruins the eye.

The removal of the cataract without iridectomy frequently leads to the loss of the eye ten or twenty years later, if not at the time.

I have tried to give you an intelligent, general idea of cataract and its treatment. Any further information desired must be requested by letter.

---

### A Word on Watch Oils.

Where can we get a good, serviceable watch oil?

This question forces itself upon the watchmaker every little while, after he has found out to his vexation that the oil which he employed for some time does not comply with the reasonable expectations made of it, and the question will be an open one until we are furnished with an oil that shall answer all reasonable demands, and is recognized as serviceable by the majority of watchmakers. Some of the oils found at present in commerce are open to one objection, the others to some other one. What with these shortcomings and defects of the oils, the watchmaker is constantly in "a sea of troubles" with his customers, who blame him for careless work.

The queries as to some brand of oil are frequently answered in different manners by colleagues. Its faults are often wittingly withheld, for reasons of delicacy, and the interrogating watchmaker who, by the insufficiency of the lubricant he customarily employed, is forced to change it for some other make, will, after all, have to depend on good luck with the next lot.

But why trust to good luck? Most surely the oil can be tested for its quality before it is used, many a watchmaker will rejoin. He will even prescribe the *modus operandi* for doing it. Place a few drops of it upon brass or copper in small sinks or gutters upon an inclined plane—a custom universally employed—and from the result you may form a judgment of its different virtues, whether it is too viscid or too liquid, whether it attacks the metals, whether it is inclined to volatilizing, thickening, drying, or other vexations, whether it congeals in the cold, or when brought between two metallic plates it becomes sticky. If none of these evils are visible after the course of several days or weeks, the oil is deemed to be very good, and is without further thought's taken into use.

Also I have observed this mode of testing, and deducted my conclusions therefrom, and have at present nine different sorts of oil under testing on brass and copper. But I have recently found out how unreliable this mode is, and I deem the experience I gathered important enough to be published for the information of my colleagues, at the same time soliciting them, in case their observations should coincide with mine, to also publish their deductions.

I have arrived at the conclusion that one sort of oil which retains its fluidity for years in brass holes becomes viscid in the same length of time in the jewel holes of the same watch, and that another brand of oil possesses the exact opposite properties. To what purpose, therefore, is a test upon brass by which we do not obtain information how the oil will behave in the jewel holes?

I will illustrate by facts. About two years ago our two shop regulators—which is equal to saying two astronomical clocks executed in the most careful manner—were cleaned, and an oil labeled as "Finest animal oil for chronometers and watches," was used for lubricating. Both clocks at first preserved good rates, but gradually retarded to such a degree that it became at last necessary to take them down. The oil in the jewel holes, of finest rubies, was completely dried up; it was as thick and brown as cold carpenter's glue, while in the brass holes, although being light green, it was perfectly fluid and capable of rendering good service for years. The pivots working in the rubies, as well as the shoulders, and even a part of their arbors, were completely black, while those in brass had preserved their polish. I would also add that one of the clocks was about eight months ago oiled again with an oil of a very renowned German brand. The condition of the oil in both clocks was exactly the same. I would also state that the temperature in our shop is very variable; we have sometimes 10° R. in the morning and 20° R. in the evening. This, of course, has also a deteriorating effect upon the oil; but why to such a degree I cannot understand.

Another observation with an English oil I made and found that it acted in the contrary way, as I have observed in a great many watches. While the oil in the jewel holes is limpid and fluid, it becomes thick and black like tar, and attacks the pivots (I have met with cases where it acted thus in less than six months). If a watch came back I knew that the pivots were to be polished and the holes bushed. What is the reason of this?

It is almost unnecessary to mention that the blame could not be laid to the workman. Our shop employed twenty repairers, and everyone was required to perform his work with the most painstaking scrupularity.

Although it is sufficiently well known that the quality of the brass exerts an important influence upon oil, I will nevertheless mention an occurrence which happened to me lately. I had, as I said above, nine kinds of oil for testing upon brass. Among these is also a sort which I have employed for watches for years, and have often lubricated with it a small so-called French regulator, which had gone

eleven full years before it was cleaned, and it was then only due to the accident that the spring had become unhooked. The oil had not thickened in the least, but was inclined to volatilize, wherefore I re-supplied it every two years. After cleaning (both the pivots and holes had been preserved perfectly during this time) I again used the same oil.

The oil tests upon brass I performed four months afterward, and imagine my astonishment when after a few days the same oil, which I had applied in four little sinks, had turned full green. I at once took down the movement of said regulator to examine its condition, and found that its oil was perfectly clear, and did not exhibit the least trace of assuming a green color. Consequently the fault was due to the brass I had chosen for instituting the tests. It is very possible in this manner to pronounce an oil as useless while it possesses good, useful qualities.

I reiterate the solicitations to my colleagues to publish their experiments and experience in this line. The subject is of too grave a nature to be treated slightly or silently.—[OTTO BEHREND, St. Petersburg, Russia, in *Deutsche Uhrm. Ztg.*

### The Jewelers' Safety Fund Society.

THE FOLLOWING bill was introduced in the New York Assembly recently, read twice and referred to the committee on insurance—reported favorably from said committee and committed to the committee of the whole. It will, no doubt, be passed by both houses and approved by the governor.

*An Act to incorporate "The Jewelers' Safety Fund Society," of the City of New York.*

SECTION 1. The following named persons and their successors, viz.: Enos Richardson, Henry Randel, Ira Goddard, Samuel W. Saxton, James C. Aikin, Samuel C. Scott, Charles G. Alford, William R. Alling, Frederick S. Douglas, Courtland E. Hastings and Henry Hayes are hereby constituted a body corporate by the corporate name of "The Jewelers' Safety Fund Society," and such society shall possess the usual powers of corporations in the State of New York, and its principal place of business shall be in the city and county of New York.

SECTION 2. The corporation hereby created shall have power to insure manufacturers or importers of, and wholesale or retail dealers in, watches, watch movements, jewelry, diamonds, precious stones, plate, ornaments and similar goods, against loss of or damage to any such merchandise, goods or articles owned by such manufacturers, importers or dealers, or held by them in trust or on commission, or sold but not delivered, or in which they have any interest or for which they are in any respect liable, by any and all risks of fire, theft, barratry and embezzlement, and any and all risks of transportation by land or water, during all or any period or periods of time whilst such merchandise, goods or articles are outside of the stores, offices and manufactories of the assured, whether the same are in the custody of the assured, their clerks, salesmen, agents or servants, or of any express or transportation line, or in letters or packages in the mail, or in the custody of any other person or corporation, to whom they may have been intrusted or delivered by or on behalf of the assured, their clerks, salesmen, agents or servants.

SECTION 3. The said corporation may, for the purposes aforesaid, issue to the members thereof policies of insurance signed by its president, and by its treasurer or secretary, agreeing in the name of said corporation, to pay all loss or damage which may be sustained by the holders thereof by means of any or all of the aforesaid risks, during the term or period specified in such policies, not exceeding the sum named therein.

SECTION 4. The persons named in section one of this act shall be the directors of said corporation, to serve until their successors shall be elected as hereinafter provided.

SECTION 5. The directors shall adopt by-laws not inconsistent with this act to prescribe the qualifications and mode of admission of members; the admission fees or dues payable by members; the manner of holding meetings of members or directors, other than the annual meetings, and the number necessary to constitute a quorum at such meetings; the powers and duties of officers and committees; the terms and conditions of policies; the rates of premium; the manner of receiving and passing upon applications for insurance and of adjusting and paying losses; and such other details of carrying on the business of said corporation as they shall deem necessary. Such by-laws shall also provide for the receipt and approval by the directors of a certain aggregate amount of applications for insurance before said corporation shall issue any policy of insurance, and may be rescinded, amended or altered in the manner therein provided for. An individual, co-partnership, or incorporated or unincorporated company, may be a member of said corporation under such regulations as shall be prescribed by the by-laws.

SECTION 6. There shall be an annual meeting of the members of said corporation at the city of New York, on the second Wednesday of January in each year, at which a board of eleven directors shall be elected by a majority of the votes of the members present in person or by proxy, each member being entitled to one vote for each sum of one thousand dollars of insurance by said corporation then held by such member. No particular number of members shall be required to constitute a quorum at such annual meeting.

SECTION 7. The directors shall annually elect from their own number a president and vice-president, and shall select five of their number who, with the president and vice-president, shall constitute an executive committee. The directors shall also appoint a treasurer and secretary, but the same individual may be both treasurer and secretary; and such officers need not be members of the corporation.

SECTION 8. The said corporation shall have power to levy assessments for the payment of losses arising under its policies of insurance, such assessments in every case to be made upon all holders of policies of said corporation at the time when the loss for which the assessment is levied occurred, including the holder of the policy under which the loss occurs, and upon no others. Each policy holder liable to assessment as aforesaid shall be assessed in a sum bearing the same proportion to the total amount assessed as the amount of insurance held by such policy-holder at the time the loss occurred bears to the total amount of insurance by said corporation in force at that time. In case of the death or dissolution of any policy-holder after a loss shall have occurred, such assessment shall be levied upon the personal or legal representatives or successors of such policy-holder, to be paid out of the estate or assets of such policy-holder in due course of administration or liquidation. The mode of levying such assessment, and notifying the policy-holders thereof, shall be prescribed by the by-laws, and the sum assessed upon each policy-holder shall become due and payable to said corporation at the expiration of sixty days from the service of such notice.

SECTION 9. Any policy issued by said corporation may be canceled by the directors at any time by giving ten days' notice in writing to the holder thereof, and repaying such part of the premium paid thereon as shall be proportionate to the unexpired term thereof; and any member may at any time surrender any policy held by him upon giving thirty days' notice thereof in writing to the corporation, and thereupon shall be entitled to receive back such rebate of premium as may be established by the by-laws; and any member may withdraw from membership in said corporation by giving thirty days' notice in writing of such withdrawal, and surrendering all policies held by him as above provided; but any member whose policy shall be so canceled or surrendered, or who shall so withdraw from membership, shall continue liable to assessment in accordance with the provisions of section eight of this act, for payment of losses which occurred prior to such cancellation, surrender or withdrawal.

SECTION 10. This act shall take effect immediately.

### Business Changes.

L. Sauter has admitted to partnership R. Stahl, who will conduct a manufacturing jewelry business under the firm name of L. Sauter & Co.

Edward Todd, Jr., and Henry C. Potts have been admitted to an interest in the business of Edward Todd & Co.

The firm of Howard, Scherrieble & Co. has been dissolved by mutual consent, Mr. Scherrieble retiring; the business will be continued by H. and S. C. Howard, under the firm name of Howard & Son.

The firm of Baldwin, Sexton & Peterson has been dissolved by mutual consent, Messrs. Moses G. Baldwin and R. N. Peterson retiring from the firm. Messrs. Aug. W. Sexton and Aug. W. Sexton, Jr., have formed a co-partnership for the purpose of conducting the business, which will continue to be known under the firm name of Baldwin, Sexton & Peterson in accordance with the statute of this State, governing "an act allowing the continued use of co-partnership name in certain cases."

Mr. R. N. Peterson, late member of the above firm, will continue to deal in diamonds and other precious stones at 692 and 694 Broadway, under his own name.

The firm of Haug & Luthy has been dissolved by mutual consent. A. Luthy, for several years in the factory of Baldwin, Sexton & Peterson, will continue the manufacture of fine diamond mountings, jewelry, etc.

The firm of Schnurbusch & Thie is dissolved by mutual consent; H. Schnurbusch will continue the business.

The co-partnership existing between Barnet Bros. & Powell has been dissolved by mutual consent, Messrs. Barnet Bros. having purchased the interest of J. H. Powell. The business will be hereafter continued under the firm name of Barnet Bros.

The firm of S. W. Hale & Co. has been dissolved by mutual consent, W. H. Howes and W. A. Lee retiring; the business will hereafter be conducted under the name of S. W. Hale.

The firm of Wood & Hughes having been dissolved by reason of the death of Mr. Chas. Wood, the business will hereafter be continued under the old firm name by S. T. Fraprie, Henry Wood and Dixon G. Hughes, members of the firm of Wood & Hughes.

### Foreign Gossip.

**PATENT LAW IN SWITZERLAND.**—There is a possibility that before long Switzerland will have a patent law, the result of the recent exhibition at Zürich having convinced the authorities that owners of new machines declined to exhibit on the ground that they had no protection from the enterprise of piratical parties.

**LOUIS BREGUET DEAD.**—We are sorry that we have to chronicle the decease of Mr. Louis Breguet, the grandson of the famous A. L. Breguet, the founder of the house. Mr. L. Breguet was a distinguished mechanic and electrician, and contributed many important papers to the Bureau des Longitudes. He was born December 22, 1804.

**COUNTERFEITS.**—We see by our English exchanges that some villain, not having the fear of the law before his eye, has basely counterfeited Hanoverian sovereigns. Just think of it. We should have presumed that England got too much of the Hanoverian sovereigns, without counterfeiting them. America did and drove them out in 1776, both the genuine and the counterfeit.

**ERICSSON'S SUN MOTOR.**—We see by the daily press that Captain Ericsson is engaged upon a motor worked by the solar heat. The rays of the sun are caught and carried to a reservoir, where their heat converts water into steam which is used for running a small engine. This invention is designed to be used in pumping water on the plains, where its small cost would make it very valuable.

**PEARLS.**—A few years ago the pearl oyster was discovered in New Guinea, and pearls are said to have lately been found there in large quantities. A correspondent to a European paper writes that he has seen very beautiful pearls fished there. Shortly before he left the island he saw one of the size and shape of a pigeon's egg. Whether these stories be true, or whether they are fabricated to draw on settlers remains to be seen.

**ALUMINUM.**—Our English exchanges say that more than 20 tons of aluminum metal have been worked into gold and sent to the Calcutta Exhibition. One firm have adopted it for pens and pencil cases, another for screws and another for swords. It has been extensively employed for chandeliers, locks, optical and surgical instruments, and on the whole the metal is excellently well adapted for the purposes of the metal or goldsmith.

### Trade Gossip.

F. I. Marcy & Co. have opened an office at 1½ Maiden Lane, where a full line of Acme buttons in all styles may be seen.

Quite a number of liberal buyers from the west were in the city last month making selections for the spring trade. They report the outlook for business as promising, and hope to have a larger amount of sales this year than last.

Messrs. H. Muhr's Sons are making noticeable improvements in the manufacture of their filled cases, and are now presenting some new designs that are attracting considerable attention. Their new glyptic letters for monograms are considered tasteful and elegant, and are having an unprecedented run.

George C. F. Wright, a well known jeweler of this city, died at his home in 152d street last month, from paralysis of the brain. He had been confined to his room for two months, and the cause of his illness is said to be overwork and the constant worry attendant on the care of an invalid wife. He was born in Montague, Franklin county, Mass., in 1841, and he came to this city at the age of seventeen. Some years afterward he became a partner in the firm of Giles, Wales & Co., who did business at No. 13 Maiden Lane. At the dissolution of the firm in 1874, he continued in business at the same place, taking a partner and trading under the firm name of Wright, Kent & Co. Several years ago he assumed sole charge of the business which he has since conducted alone. He leaves a widow but no children. Mr. Wright was a member of Kane Lodge, F. and A. M., and also of the Jewelers' League.

The store of Emanuel Marks & Son, at Troy, New York, was entered by burglars on Saturday night, Feb. 24, and robbed of goods valued at \$50,000. The burglars gained access to the basement of an insurance office adjoining Mr. Marks' store, cut a hole through the brick fire wall and ascended to the store. Here they blew the safe open with powder, secured the contents, and also took what they wanted from the show cases, escaping without being observed. It is supposed that the robbery took place after daylight Sunday morning, as a watchman declares everything was all right at 6 o'clock. The burglars were evidently good judges of the quality of goods, for they left the plated ware, but secured the diamond and gold goods, 75 gold watches, and other goods of intrinsic value. They overlooked, however, some diamond jewelry and some unset diamonds. This is the second time Mr. Marks has been robbed, and the loss falls very heavily upon him.

Early in February, considerable comment was excited by the failure of Wm. A. Smith, a diamond dealer doing business in Boston. Mr. Smith had been in business a number of years, and seems to have enjoyed a more extended credit than was warranted by either the amount of his capital or his business capacity. His liabilities amount to \$171,038, and his assets are reported at \$120,000. He offers to compromise at 40 cents on the dollar, which offer the creditors now have under consideration. He is reported to have overstocked himself during the past year, having purchased some \$300,000 worth of goods, while his sales were scarcely half this amount. As his paper fell due he got into the habit of hypothecating portions of his stock to raise money to meet maturing notes. Mr. Smith had always been a liberal buyer in New York, and was highly esteemed by the houses with whom he did business. His failure is another illustration of the credulity of the creditor class in the trade, which goes on giving unlimited credit without inquiry. While the integrity of Mr. Smith is not questioned, it is conceded that he was not thoroughly acquainted with the requirements of his market.

## Workshop Notes.

**GENERAL DIRECTIONS FOR BRONZING.**—The choice of bronze powders is of course determined by the degree of brilliancy you wish to obtain. The powder is mixed with strong gum water or isinglass, and laid on with a brush or pencil, and not so dry as to have still certain clamminess; a piece of soft leather wrapped round the finger is dipped into the powder and rubbed over the work. When the work has been all covered with the bronze it must be left to dry, and loose powder then cleared away with a hair pencil.

**PASTE OR GLUE FOR PAPER LABELS.**—The following recipe is said to make a first-class mucilage for gumming large sheets of paper which may be kept for use without culling, and stick well on glass or other substances when wet. Starch, 2 drachms; white sugar, 1 ounce; gum arabic, 2 drachms; water, *quantum sufficit*. Dissolve the gum, add the sugar and boil until the starch is cooled. Try also the following, said to be that used on postage stamps: Gum dextrin, 2 parts; acetic acid, 1 part; water, 5 parts. Dissolve in a water bath, and add alcohol, 1 part.

**BRONZE POWDER.**—Bronze powder of a pale yellow color is produced from an alloy of  $13\frac{1}{4}$  parts of copper and  $2\frac{3}{4}$  parts of zinc; of a crimson metallic luster from copper; of a paler color copper, and a very little zinc; green bronze with a proportion of verdigris; of a fine orange color, by  $14\frac{1}{2}$  parts copper and  $1\frac{3}{4}$  parts zinc; another orange color,  $13\frac{3}{4}$  parts copper and  $2\frac{1}{4}$  parts zinc. The alloy is laminated into very fine leaves with careful annealing, and these are levigated into impalpable powders along with a film of fine oil, to prevent oxidizing and to favor the levigation.

**DRILLING HOLES IN GLASS.**—O. A. G. writes as follows: I have found it more expeditious to use for this purpose the process adopted by the "wild Irishman when he bores a hole in the solid rock"—namely, an instrument of hardened steel, with a cold chisel edge. I used a tool called by carpenters a screw-driver bit. This is held in the left hand with its cutting edge in close contact with the glass, while light, rapid blows were struck on the other end with a tack hammer, or preferably a small wooden or lead mallet, the drill being constantly but slowly rotated, and the point of contact kept wetted with spirits of turpentine.

**GILDING AND SILVERING ON WOOD.**—The wood must be coated with size. To make this, boil half a pound of parchment shavings with three quarts of water, constantly stirring. This gives a clear solution of gelatine, which must be passed through a sieve. Paint over the wood with this, and, while it is still moist, apply gold or silver leaf or Dutch metal. Much manual skill is necessary, and it is well to see the exact details practiced by a gilder. Wood may also be gilded by mixing bronze powder with copal varnish, and painting it with the mixture. Finally, gold paint may be bought all ready for use, and this will probably give the most satisfaction.

**HOW TO PRODUCE MOLDS DIFFERING IN SIZE FROM THE MODEL.**—The following is a new and very ingenious method which may in time grow into an industrial branch. With a little practice any amateur should be able to turn out acceptable work. The process consists in first enveloping the model in a jelly of agar-agar (a Chinese gelatine made from certain sea-weeds), by pouring the hot aqueous solution over the model contained in a suitable box, then to extract the model, painting the inside of the agar mold with glycerine, and then to fill this mold with gelatine previously grueled in cold water and rendered liquid by a gentle heat; but which has also been rendered more firm by incorporating a little of some fine powder, such as chalk, talc, etc. After removing the agar covering, the gelatine counterfeit may now be enlarged by soaking in cold water, or it may be reduced in size by soaking in strong alcohol, whereby water is abstracted. The changes in size progressing uniformly, these gelatine models may now be used from which to take plaster of Paris copies. This process of reduction or magnifying may be extended almost indefinitely in either direction by repeating the above process.

**MANUFACTURE OF WATER LACQUER.**—A water lacquer, which is cheaper than alcohol lacquer, and which at the same time is very adhesive, is prepared by heating in a steam bath 10 parts borax with 30 parts coarsely powdered white shellac and 200 parts water. When completely dissolved, in a few hours, the liquid is left to cool and filtered. This water lacquer becomes still more flexible by the addition of a few drops glycerine. If to be desired a deep black, pour in a certain quantity of water-soluble nigrosin; for red, the different eosins and fuchsins; for blue, methylene blue, alkali blue or marine blue; for green, malachite green or brilliant green; for violet, methyl violet.

**SOLDERING A RING WITH JEWEL.**—In order to prevent the bursting of the jewels of a ring when soldering the latter for repairs, take a juicy potato, cut it into two halves, make a hollow in both portions in which that part of the ring with the jewels fit exactly, so that that part of the ring to be soldered protrudes. Then wrap the jeweled portion in fine silk paper, place it into the hollow and bind up the closed potato with binding wire. Now, solder with easily-flowing gold solder, not upon a coal, but by holding the potato in the hand. Another good way to do the same job is to fill a small crucible with wet sand, bury that part of the ring with jewels in the sand and then solder.

**DELTA METAL.**—This is a new alloy, patented in Germany, employed in the manufacture of church bells, steam pumps, fire engines, and, in fact, all articles in which strength and durability are required, the main feature being the introduction of a certain percentage of iron into an alloy of copper and zinc, whereby the latter is rendered harder and more tough. Zinc, under varying temperatures, will assimilate iron to the extent of about 9 per cent., 3.5 per cent iron being retained at a dark-red heat. This alloy being completed the requisite amount of copper is added, and finally a little manganese. Alloys of various properties are obtained by changing the proportions of the compound metal.

**REMEDY FOR FROST BITES.**—Even watchmakers, goldsmiths and others who read THE JEWELERS' CIRCULAR, are not exempt from the ills that flesh is heir to, consequently they will freeze their toes or fingers. Should this have occurred bind up the frost bites in very cold water (snow water is best), using a linen rag, and repeat the poulticing until the rag does no longer heat. Do this before going to bed and you will find next morning that the frost bites have disappeared. If they appear to be obstinate, repeat the poulticing for one or several evenings. This simple remedy is not as well known as it should be and other very barbaric ones are resorted to, such as extracting the frost by holding the part affected over the fire, etc.

**MANUFACTURE OF EMERY DISCS, ETC.**—For the information of the many readers of THE CIRCULAR who live far from watchmaker's material houses, and who, consequently, are thrown greatly upon their wits' end, we would recommend the following method: A mixture of glue and emery is excellently well adapted for the manufacture of grindstones, grinding discs, files, etc. Those composed of fine sand and shellac rank among the best of the artificially produced grindstones. To prepare them, heat an intimate mixture of pulverized shellac and sharp quartz sand, until the former melts, then press it into forms. Do not use more shellac than is actually necessary to form the grains of sand into a compact mass. For the manufacture of large-sized grindstones surround an iron drum with a shellac mass; if emery powder in place of sand is employed, the quality of the grindstone will be improved. The smaller emery files can also be prepared from this mass. Use three parts by weight of emery and one part by weight of shellac. A hard wood core is excellently well suited for a small grinding disc. In order to prepare a good glue for these purposes, it is necessary to steep it for 24 hours in water, so as to soften it gradually.

## Trade Gossip.

Fine rubies are very difficult to obtain, consequently are held at high figures.

Ruby watch jewels have advanced 20 per cent. within the past three months.

Simon Stern, of the firm of Stern & Stern, who has been suffering from pneumonia, has recovered, and is once more attending to business.

Messrs. T. H. Bloch & Bro., importers of watches, will shortly retire from business. Adolph Schwol will occupy the offices of the retiring firm.

C. D. King, for some time traveler for Aikin, Lambert & Co., has returned from the road and accepted a district agency for the Massachusetts Mutual Life Insurance Company of Springfield.

The costliest dog collars, generally worn by pugs, are of gold and silver set with diamonds, opals, rubies, emeralds, and other jewels, the initial letters of which spell out the name of the wearer or its fair owner.

C. H. Spencer, formerly with Wm. B. Clapp, Bros. & Co., of Chicago, is now in the employ of A. J. Warner & Co., of Minneapolis. Mr. Spencer is a very popular salesman, and has gone West to grow up with the country.

John Holland, of Cincinnati, manufacturer of gold pens bearing his name, which have a wide-spread reputation for excellence, offers a large and varied assortment of goods in his line, embracing all the latest novelties and many new designs.

The business of the late Ludwig Lehmann will be conducted at 122 Fulton street under the management of his brother, Leopold Lehmann, where a large and attractive line of paper jewelry boxes of every description and style of decoration may be found.

There has recently been a considerable advance in diamonds, owing to the fact that the stock of fine diamonds has been absorbed and none of this class are being found. There has been, however, no material change in what are known as mercantile diamonds.

Miles W. Evans, who had charge of the New York office of C. N. Thorp & Co., is now in the employ of the Ladd Watch Case Company. Mr. Evans is well known and popular in the trade, and will, no doubt, find his present connection more congenial, while his new employers are to be congratulated on having secured the services of so energetic a representative.

Paul Dittman, alias Krouse, about five feet ten inches high, broad shouldered, high forehead, broad face, dark complexion and dark hair, speaks English with marked German accent, is a good watchmaker, and understands adjusting and complicated work thoroughly, is about 30 years old. Any information concerning his whereabouts will be appreciated. Address this office.

Three thieves recently attempted to rob the jewelry store of A. Stucke, of Burlington, Iowa, but got left. One of them asked Mr. Stucke to see what was the matter with his watch, and while Mr. Stucke was examining it another crawled under the show case and attempted to remove some of the goods therein. Mr. Stucke saw and pounced upon him, when a struggle ensued between him and the three thieves, but one of them presented a pistol at Mr. Stucke's head, thereby disconcerting him, and the robbers escaped. Upon investigation Mr. Stucke found that he was out \$80 worth of goods and ahead to the extent of a gold watch worth \$125. They had previously tried the same game on Mr. Henry Waldin, of the same place, but his vigilance defeated their little game.

In the early part of November, 1881, William Nichols, a jeweler, doing business in Toledo, parted with some \$19,500 worth of goods to one D. M. Keene, an auctioneer of that city, after which Nichols suddenly disappeared. The creditors suspecting that there was something "crooked" in the transfer, attached the goods in the hands of Keene, and, when sold by the sheriff, bought them in to protect the local trade, giving the sheriff indemnity bonds. Keene next brought suit against the sheriff to recover the value of the goods, and the case thus assumed quite a complicated complexion. Recently the case was brought to trial before a jury, when a verdict was given in favor of the attaching creditors. It will be seen from this that where creditors persistently follow up transactions of a suspicious character the courts and juries will contrive to find out the equities of the case and give judgment accordingly.

E. B. Melcher, of Adrian, Mich., was recently robbed of fifty-four watches left for repairs, by three thieves, one of whom was his apprentice. They got away with the goods, but the apprentice returned, confessed the robbery, and was lodged in jail. The others carried off the watches, and had not been arrested at last accounts. A reward of \$200 is offered for their apprehension.

An iron post on the south side of Murray street, near Broadway, supports a clock with four dials. The dial which faces Broadway has a gilded surface with two sets of numerals. Those near the circumference are Roman, and range from I. to XII., as on the ordinary clock. They are black on gold. The other set are Arabic numerals, running from 1 to 24, and are gilded on a narrow black circle just inside the other circle. A single gilded hand points out the time on both sets of figures. The dial is elaborately ornamented, and represents the dial of a watch in Prince Pierre Soltkoff's collection, which is believed to be fully 300 years old. The case of this watch is described as of gold and enamel of most elaborate workmanship, the sides being of rock crystal. Its actual age is not absolutely ascertained, but from certain characteristics of the movements it is believed to date from the beginning of the reign of Henry II. of France.

Burglars recently entered the jewelry store of E. A. Weitzle, Reading, Pa., in the early morning, and robbed the money drawer of \$50, and cleaned out a case of watches and jewelry, besides taking some thirty watches left for repairs. The value of the property stolen is said to amount to \$4,000. Mr. Weitzle has a safe large enough to hold all his stock and money, but left much of it in cases on the counter, for the reason that he slept in a room adjoining. The burglars entered through a transom over the front door. It is believed that a man assuming to be an agent for a Philadelphia firm, who was in the store a few days ago endeavoring to sell an electric burglar alarm, was in league with if not one of the burglars. He told Weitzle that it would be an easy thing to rob his store, as an entrance could be gained through the transom, and by questions succeeded in gaining information as to the manner in which the store was guarded at night.

Some months ago Leon Cronson, a traveler in the employ of Goldsmith & Kuhn, of this city, was reported to have absconded with goods belonging to the firm valued at \$25,000. In consequence of this the firm made an assignment. Subsequently the whereabouts of Cronson was discovered, and he was arrested in Chicago with some of the goods in his possession. He admitted to the detective that on December 20 he took goods amounting to \$10,000 to Joseph Schwartz, a pawnbroker in Kansas City, who agreed to advance \$2,000, paying \$400 cash. Upon calling for the remaining \$1,600 Schwartz called him a thief and a swindler and would not give him the money. Fearing that Schwartz might make trouble Cronson went to Chicago and there left the remaining stock, worth \$15,000, with his friend, Julius Edwin, who agreed to put it in a safe-deposit vault. Instead of this Edwin sent the goods to his sister, who subsequently returned \$12,000 worth to him, and these he sent to different cities by express to be called for. These were recovered, and the Kansas City pawnbroker also surrendered those in his possession. Cronson was held for examination.

Some time since S. Rothschild, of Memphis, bought several thousand dollars worth of diamonds of New York dealers, and a few weeks afterwards made an assignment to Louis Rosenthal. When the assignee made his report it was found that scarcely any of the diamonds were included in his stock schedule. Criminal proceedings were begun against Rothschild, and on being brought to trial he was found guilty of having wrongfully converted the property, and was sentenced to three years in the State prison. The creditors suspected that Rothschild had deposited some of the goods with various ones of his friends, and the court granted an injunction restraining them from parting with the property, and also a summons requiring them to answer certain questions. The complaint against Rosenthal, the assignee, was that he had concealed certain property in the interest of Rothschild, who was his intimate friend. The result of the proceedings against him we have not learned. The conviction of Rothschild was a great surprise to himself and his friends, who had confidently expected his acquittal. This case is of importance to the trade, as it indicates that persons who attempt to swindle by fraudulent assignments can be reached by the law when followed up with energy. Counsel for Rothschild have made a motion for a new trial, and the final outcome of this decidedly mixed transaction will be looked forward to with interest.





VOLUME XV.

NEW YORK, APRIL, 1884.

No. 3.

## THE JEWELERS' CIRCULAR AND HOROLOGICAL REVIEW

*The recognized organ of the Trade, and the official representative of the  
Jewelers' League.*

A Monthly Journal devoted to the interests of Watchmakers, Jewelers, Silver-  
smiths, Electro-plate Manufacturers, and those engaged in the  
kindred branches of art industry.

### SUBSCRIPTION:

To All Parts of the United States and Canada,  
**\$2.00 Per Annum; Postage paid.**

To Great Britain, France, Switzerland, Germany, the West Indies, Mexico, the  
Republics of South America, and Australia, \$3.00 per annum. Postage paid.

All communications should be addressed to D. H. HOPKINSON, 42 Nassau  
Street, New York. Advertising rates made known on application.

### The Prospects of Trade.

WE HAVE noticed recently in the daily papers interviews with prominent business men, both of the east and west, relative to the business outlook for the coming season. With one accord the persons interviewed have predicted a prosperous year in all lines of trade, and give as reasons for the faith that is in them the promise of abundant crops and the abundance of money in the country. While we are willing to admit that the crop prospect is as good as ever they are at this season of the year, and that the banks have more money in hand than they know what to do with, we cannot agree that the outlook for business is particularly promising. We anticipate simply a fair, moderate, steady-going trade, with but little fluctuation, scarcely exceeding in amount the trade of the last two years. The fact is not generally appreciated that during the past two or three years the country has been in a state of liquidation, getting rid of its excess of values, and bringing business down to a bed rock basis. As a matter of fact there has been a shrinkage in market values during this period that exceeded the shrinkage that took place during the panic of 1873. Then the shrinkage came suddenly causing a crash and a collapse; now the liquidation is going on quietly, slowly and evenly, affecting all classes of property equally and consequently has not been felt as it was in 1873, and has not resulted in disaster. The water is being squeezed out of all enterprises, speculative and otherwise, and business is based on intrinsic rather than fictitious values. Instead of producing a panic and carrying down to universal ruin business houses without number, this process of liquidation has made dull times, and all lines of business have felt its effects. Men have not had the confidence to engage in great undertakings; manufacturers have not been active; speculators have not seen their way to making investments; and the money that should have been diffused throughout the country has accumulated in the banks where it lies idle, and cannot be loaned

satisfactorily at any price. Some of the trust companies and banks have been so burdened with the money of their depositors that they have notified them that they would pay no interest whatever and would prefer to have them remove it. It is no wonder, therefore, that business has been dull, and we must expect it will continue to be so just so long as business men lack confidence in the future, and see no indications of the dawn of coming prosperity.

While this has been the condition of general business during the past two or three years, the jewelry trade has cause for rejoicing that it has passed through this season of liquidation with so little of disaster. There have been fewer failures in the trade during the past year than in almost any other line of business, an indication that dealers generally have had less indebtedness than usual to provide for, and that they have endeavored to cut their suits according to their cloth—that is, have bought goods as they needed them rather than overstock themselves in the spring and fall rushes. They have followed the advice so often repeated by THE CIRCULAR, and bought according to the demand instead of piling up goods promiscuously and waiting for the demand to grow. Of the failures of the year, but one or two were of sufficient magnitude to cause apprehension, while the number of small ones was less than usual. The introduction by retail dealers of kindred goods to diversify their stock and keep up their sales has served to tide many of them over the shallow places and bring them safely into port. It has also enabled them to reclaim some of the trade that had drifted away from them and into the hands of outsiders. By judicious treatment this trade can all be won back to the legitimate dealers in the course of a few years.

The business men who have been interviewed sanguinely predict a "booming" spring trade; we do not so read the signs of the times; on the contrary, there are many reasons that combine to make us apprehend a dull spring trade, with a prospect of a gradual improvement toward the fall. The process of liquidation we have alluded to has left business men without confidence to undertake extended enterprises in any field of action; the winter has been a remarkably severe one in the west and south especially; these sections have also been visited by floods, cyclones and mud blockades, and all industries have suffered in consequence. Add to this the actual loss of property entailed by these several disasters, and it is not surprising that the dealers in those sections are somewhat discouraged, and are unable to see where they are to find a market for their goods. As a consequence they will buy lightly at this season, trusting to the facilities afforded them for ordering what they want from time to time as circumstances require. This is certainly the part of wisdom, and the trade would be a gainer if it were more generally followed at all seasons. Another thing that tends to depress trade of all kinds is the constant menace held out by Congress that it is going to tinker with the tariff. It is not so much what is done, but what is threatened in this direction that operates to deter business enterprise. Men cannot afford to take the chances of buying foreign goods and paying the present duties on them when Congress is constantly threatening to take off the duties or to lower them. This

threatened peril of tariff tinkering by botch workmen serves to paralyze the industry of the country to a great extent. If Congress could be abolished for five years it would be a blessed boon to business of all kinds.

We are always better pleased when we can write cheerily of the business outlook, but he would be an over-sanguine man who should predict anything like a "boom" in the jewelry business for some months to come. The trade is to be congratulated, however, that the worst of the dull times are over and with so little disaster to its members. The reaction is setting in, and a marked improvement, especially in real estate, has taken place in the past few weeks. This will gradually expand like a ripple upon the water, until all lines of business feel its effects. With a restoration of confidence in all circles, we may look for that "boom" in the jewelry trade that all are so anxiously anticipating. But it behooves every man in the trade to study carefully the events of the day as they transpire, to be cautious, to hold his forces in reserve, to be conservative in all his transactions until the time comes for him to put forth all his energies once more to increase his business. It is better to move slowly and surely than to take the chances of bankruptcy. This advice, we know, will not suit some manufacturers who are always seeking to overstock retail dealers and load them down with goods, whatever may be their chances of selling them, but we are certain we are consulting the best interest of the trade at large when we counsel retail dealers to be cautious in their purchases, buy in moderation, pay for what they get, and above all avoid the temptation to overstock. Travelers for manufacturers and jobbers can exercise a good influence in this direction if they choose, but their anxiety to sell goods too often leads them to urge dealers to buy beyond what is expedient. It is better to have a dealer as a regular customer year in and year out than to overload him and drive him into bankruptcy. Anticipating, as we do, a light spring trade, we still think it will equal that of last year, and gradually improve from month to month, culminating in an excellent demand for goods for the fall trade.

---

### The Jewelers' League.

THERE IS so much being said in the press nowadays about assessment life insurance, that it is well for the members of the trade to understand the difference between such organizations as the Jewelers' League and the swindling graveyard co-operative concerns that infest the country. A vast amount of swindling and corruption have been exposed recently on the part of what are known as assessment life insurance companies, and it is important that legitimate benefit societies should not be confounded with them. These co-operative associations are usually organized by unprincipled adventurers—generally broken down or cast off agents of regular life insurance companies—who have no ambition but to make as much money for themselves as possible, wholly regardless of the interests of the members. The societies that are doing the largest amount of business to-day are those whose officers are known swindlers, and who are successful because of the very audacity of their representations. Having neither money nor reputation to lose they attach no responsibility to their statements or promises. A person joining one of these concerns is charged a certain amount for membership fee, annual dues and assessments as deaths occur. It is given out that the membership fees and annual dues pay all expenses, but this is not true, for it will be found in a majority of cases that the amount received to pay death claims is taxed a certain percentage to pay officers' salaries. Agents for societies of this kind abound in every town, and, of course, they must be paid. It is customary to give these what is termed "100 per cent." or "130 per cent." according to their ability. This means that when an agent catches a fresh victim, he has all of the membership fee as compensation, and, if he is a general agent, from ten to thirty per cent. of the annual

dues paid by said victim thereafter. This leaves little for officers' salaries and other expenses except as they "knock down" from the death assessments. We know of a case where a widow had a claim for \$5,000 against one of these concerns; the assessment was levied on the membership for the full amount but she was paid only \$1,400. In another case, a widow held five \$1,000 certificates; she was paid \$400, but was required to receipt for \$400 on each certificate, thus receipting for \$2,000 when \$400 only was paid her. As agents receive such liberal compensation, they are anxious to get in as many members as possible, so they run in the lame, the halt and the blind, ransacking workhouses and insane asylums to find decrepit persons to insure. Hence the term "graveyard insurance." Often the agent and the medical examiner have been found to be in collusion, insuring old and sickly persons in their companies for their own benefit. Two years ago there was a regular mania in Pennsylvania for this so-called insurance, and speculators made fortunes by insuring old persons who would die before many assessments fell due. Officers of the companies engaged in the speculation, and were even found making assessments for fictitious deaths. Finally the State authorities interfered and dispersed these swindlers and their companions. They have appeared since in New York, Massachusetts and several of the Western States. These are the speculative co-operative concerns, conceived in iniquity and conducted in fraud.

Very different from these are those benefit societies that are the legitimate outgrowth of the association of men for business or social purposes. The Masons, Odd Fellows, and numerous professions and trades have their benefit societies that are organized on a purely benevolent and charitable basis. There are no officers to consume the benevolent contributions of the members, no agents to fatten on advance payments, beyond a small commission paid to a secretary to compensate him for the necessary expenditure of time and money, no salaries are paid. The affairs of these societies are managed by men who cheerfully give their services for the benefit of their fellow members. When a death occurs each member is assessed a specified sum, to which it is customary to add ten cents for postage; the whole amount derived from the assessment is paid to the beneficiary of the deceased member. The statistics furnished the state insurance department by these benevolent societies show that they are managed at a less ratio of expense than are the regular level premium life companies. In 1882 it cost the life companies nineteen per cent. for expenses for every dollar paid to policy holders; the benefit societies showed an expense of eighteen per cent., and the speculative graveyard concerns showed an expense of 251 per cent.—that is, it cost \$2.51 to pay one dollar to a beneficiary. When solicited to join one of these societies bear this fact in mind, and do not be deceived by their glib-tongued agents.

The Jewelers' League is one of the very best of these benefit societies; it is organized on a basis of pure benevolence, to enable members of the trade to contribute to the support of the widows and orphans of those who have been their associates in business or identified with the same industry. Its constitution and by-laws conform to the laws of the State, and are so framed as to hedge about the funds of the organization with every safeguard. Its officers are men of intelligence and integrity, whose standing in the trade is a guarantee of their trustworthiness. Not only has the trust reposed in them been discharged with fidelity, but their zeal has been such that the League now boasts of a very handsome reserve fund as a stand-by in a case of emergency. This reserve fund should be increased, and it would be the part of wisdom if hereafter 25 per cent. was added to each assessment, and the sum so realized added to the reserve fund. This fund would, by this means, increase quite rapidly, would serve as a guarantee that all claims in the future would be paid whatever emergency might arise, and would furnish the cement or bond of cohesion to keep the membership together. With such a reserve fund the League memberships would be equally valuable as a policy of life insurance and very much less expensive.

One of the old line life companies has adopted the assessment plan instead of the level premium with the 25 per cent. reserve, and it has proved so popular that it has within a year secured a very large membership. The reserve fund would give to the League more character and promise of permanency; now too many of its members look upon it as affording a sort of cheap temporary insurance, good enough for the time but to be exchanged for regular life insurance some day. While this idea is erroneous, and the League is intended to last as long as the jewelry trade exists, there is no question but a growing reserve fund would tend not only to increase the membership but also to give a better idea of permanency. It has been assumed that because the League has issued certificates of membership covering a large amount of insurance in the aggregate that the gross amount insured constitutes a liability. This is not so; the liability of the League is simply for death claims *as they occur*; when a death occurs, the League has a liability till that death claim is paid; when paid there is no further liability. Some of the certificates will extend beyond the lifetime of most of the present members, and will not become a claim till new members have become responsible for it. To say that it is a liability now is absurd. Fire insurance companies with limited capital carry insurance aggregating many millions of dollars, but none of this is a liability until the property burns and the policy is thereby converted into a claim. If the amount an insurance company, life or fire, has at risk was regarded as a liability, there is not one of them but would be insolvent a hundred times over. In official computations the amount of claims accrued and unpaid is regarded as a liability, while the insurance written is simply stated as the amount at risk. The League has been exceedingly fortunate thus far in the small number of claims it has had to pay. Its members cannot reasonably expect similar immunity in the future. The tables of mortality give the death rate at about ten in each 1,000 members each year, and this is what the League members should expect to be called upon to pay. As the medical examination is very rigid, of course none but sound, healthy persons are admitted. The League has the benefit of this medical selection, but it is estimated that it wears out in about five years. After the lapse of that period, the normal death rate—about ten in a thousand—is restored. As the original members have about worn out the benefits of medical selection, they are expected to die in about the same ratio as other people, and the surviving members must expect to pay the claims as they arise. Certainly the League cannot hope to pass through another year with so few death assessments as were made last year.

---

### The Diamond Fever.

THE DIAMOND fever has broken out afresh. It was to have been expected. The production of diamonds has fallen off very materially in the African mines, and prices have largely advanced in consequence. America, therefore, carries the war into Africa, figuratively speaking. It was necessary that new mines should be discovered, and, of course, it was to be expected that America would come to the front. She always does in an emergency. This time the new diamond mine has been found in Wisconsin, somewhere near Milwaukee, where lager beer is indigenous to the soil. A man was digging a well for the purpose of obtaining water, but what a Wisconsin man wanted with water is not stated. Coming to a bed of gravel he came to a peculiar stone; it attracted the attention of his wife, who took it to Milwaukee and sold it for the munificent sum of one dollar. A diamond expert—they grow on the bushes in Wisconsin—saw the stone and pronounced it a diamond of the first water. It is as big as a canary's egg, without flaw or blemish, and of extremely fine luster. It is uncut, but will turn out about ten karats when the edges are trimmed off. We heard an old poker player once say that when he had an ace he

always drew to it, so the present owner of this Wisconsin diamond proposes to "draw to it" in the hope of getting a flush of diamonds. He has leased the unfinished well and is going to mining—diamond mining. He is confident there are millions in it, because "the elements that formed one such stone were competent to form more, and they probably did it." No doubt, but whether they left them in the bottom of the well or not is a problem yet to be solved. Some skeptical individuals might think that this single diamond might have escaped from a collection some time and hid itself, like truth, in the bottom of the well, and that no more will be found; others may think that the whole story is a fabrication and that no diamond was found. Such an unbeliever is immediately silenced by the indignant Milwaukeeans who point to the incontrovertible evidence of the well—there is the hole to prove it.

We see by the papers that still another diamond mine has been found in North Carolina—they have a chronic habit of finding diamonds in that State; they have been doing it for a century or more; single solitary diamonds that are sure to lead up to a "big find" if only a stock company can be organized with plenty of capital. We once received a letter from a man in Georgia who said he knew where there was a diamond mine; that he had three pickle jars filled with diamonds that he had picked up at intervals "kind o' permiscuous like." He wanted we should organize a stock company, come right down, buy him out and work the mine. We replied that we had received a similar letter from a neighbor of his who had also found a diamond mine, and his had the advantage that all the diamonds were cut and set ready for the market; what was the use, we argued, in buying a mine of uncut diamonds when a neighbor had such an advantage over us; still, we informed him, that if he would send us a couple of pickle jars full of diamonds for samples we would see what we could do for him. Singularly enough, we never heard from him again, and we always thought the information we gave him about his neighbor's mine of diamonds ready cut and set had a tendency to discourage him. But we see those same old mines of rough diamonds have been discovered again, only this time one is located in Wisconsin and the other in North Carolina. It is singular how they keep moving about, now throwing out one diamond here and another time somewhere else, just enough to stir up a diamond fever, sell the land and swallow up some money in visionary mining speculations. It is the same old story—one diamond, a fever, a sale, a mining company, capital swallowed up, results, *nix*. We shall soon expect to see an account of the new discovery of our old mine of diamonds ready cut, and set in all the forms demanded by an eager market. What a prolific damsel our Mother Earth is, and what credulous mortals her offspring are.

---

### Auction Plated Ware.

A GREAT DEAL of silver plated ware is being worked off most persistently through auction houses upon an unsuspecting public, and dealers who are brought in competition with it should spare no efforts to expose its true character. We recently dropped into one of these auction stores in this city where everything is sold from second hand furniture to oil paintings. It happened to be a sale of silver plated ware that evening, and the auctioneer was rattling off everything in that line at a furious rate, and pledging his word that they were of "the very best plate, and fully equal to the best goods in the market." They certainly did look well and they were purchased with eagerness by the motley crowd of men and women in attendance. Now, these goods were as near an approach to triple plate silverware as brass is to gold. They were the cheapest of cheap plate, made expressly to sell at auction. This kind of plate consists of a basis of white metal, technically known as "soft Tommy," which has been in an electro-silver bath long enough to become covered with the thinnest film of silver that it is possible to

deposit upon such surfaces. We saw some of the pieces where the plate had been worn off by the slight rubbing they received in packing and handling, and any good housewife would soon erase it with her silver polish. Such goods look all right for a short time, but when put to use, the silver plate soon disappears and "Soft Tommy" stands revealed in bold relief. The auctioneer had the names of all the prominent manufacturers at his tongue's end, and did not scruple to "guarantee" that the cheap goods he offered were of the best make. His "guarantee," of course, was of no value, for he was simply an itinerant auctioneer, here to-day and there to-morrow, who was hired by the speculators who owned the goods to sell for them, and received a commission on the gross amount of his sales. To swell his compensation he scrupled at no exaggeration, and some of his lies were of such colossal dimensions as to challenge admiration. We have heard of some manufacturers of reputable plated ware who would make up new designs in good metal as long as there was a demand for them in the trade, and would then make the same patterns in cheap plate for the auction men. The country is full of this cheap stuff that is being disposed of through the auction shops, and the public should be warned against it. The dealers in a place where such a sale is announced should make it their business to inform the public through the local press. The publication of some of the articles that have appeared in THE CIRCULAR on this subject would, no doubt, have the desired effect. We know there is a feeling among dealers to the effect that if people will buy things at auction they deserve to be swindled, but it is none the less a public duty for those who are informed to give the ignorant the benefit of their information.

SOME SMALL and comparatively unknown manufacturers of silverware have recently adopted a novel method for introducing their goods to retail dealers. A glib-tongued traveler visits the retailer and examines his flat silverware, and finally produces some spoons and forks of really attractive designs to which he calls attention, and desires the dealer to compare them with what he has in stock. They are apparently new in design and passable in finish. The traveler finally offers to exchange the new for the old goods by weight, giving ounce for ounce, and quite frequently the trade is made. No money changes hands, but it is simply a "swap"—an exchange without "boot." The traveler claims, of course, that his goods are the more valuable, but as the manufacturers have their reputations to make, they are willing to sacrifice something for the sake of placing their goods on the market and inducing dealers to handle them. The story of the exchange of new lamps for old ones is familiar to every one who ever read the Arabian Nights, but they also know that the genii who made this magnificent offer had a sinister purpose to serve. There is, do doubt, behind this "swap" of new goods for old an African concealed, and if the dealers who have been induced to enter into the transaction will assay the new goods the African will probably be found lurking in the melting-pot. Flat goods in silver are usually made of sterling silver and so marked; such goods have an intrinsic value, below which they cannot be sold any more than gold dollars can be sold for eighty cents. It costs money to keep a traveler on the road and pay his expenses, and the manufacturer who employs one expects to make a profit from his services. How is this to be done if the traveler goes about the country swapping new goods for old ones on equal terms? It is safe to say that the profit will be found if the new goods are subjected to the assaying process. There is a process in the manufacture of silver goods known as "pickling," by means of which the alloy used in the metal is eaten out of the surface; the surface is then finished, and is really sterling silver, but the metal beneath the surface is the same alloy that it was before the "pickling." Possibly the goods so readily "swapped" for the standard sterling goods manufactured by reputable houses, will be found rotten at the core

while presenting a fair and attractive exterior. Dealers who are approached in this manner may be sure that there is a sinister motive in this offer to exchange "new lamps for old ones." Their safest way is to buy their goods from manufacturers of established reputations, and let the new men "introduce" their goods through the regular channels as others do.

WE HAVE received a number of letters recently from retail dealers complaining that they are frequently in receipt of price lists sent to them by jobbers in unsealed envelopes. As these are printed they can be sent unsealed through the mails for one cent, whereas if sealed the postage is two cents. The sender thus saves one cent on every price list mailed, but he works incalculable injury to himself and the retail dealers by doing it. It is an exposure of business secrets that should be held sacred between business men. A price list is the most confidential communication a jobber can make to his customer; it constitutes a revelation of his own business practices, and is also an indication of those of the person to whom it is addressed. In popular parlance, it is a complete "give away" of the cost of goods and of the profits made on them. Such a communication should only be made confidentially, and should be so treated by sender and receiver. Unsealed envelopes, like postal cards, tempt the curiosity of all who happen to see or handle them. Post office clerks, in small places especially, are inquisitive and gossipy, and whatever passes through their hands is liable to excite inquiry and provoke comment. It is easy to see how much injury may be done by sending price lists in unsealed envelopes. Instances have been known where one dealer has conspired with a post office clerk to obtain just such information regarding the business of a rival dealer, and not long since the decision of a prominent suit turned on the point as to whether a post office clerk had shown an invoice of goods to the competitor of the person for whom it was intended. If the information contained in a price list is worth giving to a dealer it is worth paying two cents for, and worthy of being regarded as a confidential communication. Many dealers feel insulted when they receive such information in this manner, and at once throw the offending document into the waste basket, even resolving never to patronize a house that will take the risk of betraying trade secrets for the sake of saving one cent. A price list might with equal propriety be printed on a postal card as to be sent in an unsealed envelope, and neither practice should be tolerated by the retail dealers.

### The Jewelers' League.

*President*, GILBERT T. WOGLOM.....Of Woglom & Miller.  
*First Vice-President*, WM. C. KIMBALL.....Of H. F. Barrows & Co.  
*Second Vice-President*, AUG. KURTZBORN.....Of L. Bauman Jewelry Co. St. Louis, Mo.  
*Third Vice-President*, JAMES P. SNOW.....Of G. & S. Owen & Co.  
*Fourth Vice-President*, HENRY HAYES.....Of Wheeler, Parsons & Hayes.  
*Secretary and Treasurer*, WILLIAM L. SEXTON.....Of Sexton & Cole.

#### EXECUTIVE COMMITTEE.

ROBERT A. JOHNSON.....Of Colby & Johnson.  
 SAMUEL W. SAXTON.....Of Saxton, Smith & Co.  
 CLEMENT B. BISHOP.....Of Carrow, Bishop & Co.  
 JOSEPH B. BOWDEN.....Of J. B. Bowden & Co.  
 GEORGE R. HOWE.....Of Carter, Sloan & Co.  
 CHARLES G. LEWIS.....Of Randel, Baremore & Billings.

THE JEWELERS' CIRCULAR is the *exclusive* official paper of the Jewelers' League, and has been selected for the publication of all matters of interest pertaining thereto. Letters or inquiries pertinent to its business or purposes, and which might interest the trade or inquirers, will herein be answered. Address *Jewelers' League, Box 3,444, P. O., New York*, or the office of THE CIRCULAR.

At the meeting of the Executive Committee held March 7th, 1884, at which were present President Woglom, Vice-Presidents Kimball and Snow, Messrs. Johnson, Saxton, Bowden, Howe, Lewis, Sexton

and Dr. Wilbur, the following 34 applicants were admitted to membership:

G. B. Beiderhase, F. X. Becker, H. Castelberg, E. J. Dingee, Jr., L. C. Fairchild, G. P. Farnham, W. Fenton, W. G. Foster, H. P. Glor, S. M. Jacobs, C. F. Kasthuber, S. Lichtenstein, G. C. Moody, S. J. Moran, A. A. Richmond, A. H. Richmond, C. A. Rogers, S. Stern, W. H. Stevens, D. Tomkins, N. Y. City; J. Stotzer, J. F. Sandoz, E. D. Vosbury, Brooklyn, N. Y.; O. O. Stillman, New Brunswick, N. J.; M. Pfaelzer, Philadelphia, Pa.; C. A. Pendleton, Boston, Mass.; J. Schindler, Chicago, Ills.; A. L. Debouillons, Savannah, Ga.; C. Pfenning, Macon, Ga.; J. C. Meyer, Jr., New Orleans, La.; C. Bergstrand, Denver, Colo.; W. G. Harrington, Columbus, Ohio; H. W. Dawson, Dallas, Texas; G. W. Pershall, Cheyenne, W. Y. Ter.

Treasurer reported a balance on hand of \$16,170.52.

Thirteen members were reinstated, they having been dropped for non-payment of assessments 24 and 25 before it closed.

Proofs of three deaths, D. S. Barry, J. B. Goldey and G. C. F. Wright, being received, an assessment of \$6 was ordered. Six changes of beneficiary were granted; 10 applications were referred; 5 applications were rejected.

During the evening the Executive Committee, organized as a Board of Trustees, appointed Messrs. C. G. Lewis and W. L. Sexton as a Committee to invest the surplus in the treasury in government bonds and secure a safe place for keeping the same.

The meeting adjourned to meet on Monday, March 10th.

An adjourned meeting of the Executive Committee was held March 10th, 1884. There were present Vice-Presidents Hayes and Kimball, and Messrs. Johnson, Saxton, Bowden, Lewis and Sexton, also Dr. Wilbur. The following 59 applicants were admitted to membership:

M. M. Brewster, E. B. Hayden, F. D. Hoyt, H. J. Ives, A. Judis, G. W. Shotwell, N. Y. City; W. J. Donnell, Sherman, N. Y.; O. M. Atwood, Whitney's Point, N. Y.; L. J. Roehr, J. G. Schambacher, Newark, N. J.; E. W. Holmgreen, R. E. Kehl, P. A. Peterson, H. J. Rohrbach, H. G. Schramm, S. Strauss, J. A. Thelin, M. C. Witherpoon, O. W. Young, Chicago, Ills.; F. B. Lewis, C. E. Sumner, F. L. Sumner, Cleveland, Ohio; C. F. Gerhold, P. H. Wheeler, H. E. Ziplitzky, Columbus, Ohio; A. B. Clark, J. H. Lentz, Cincinnati, Ohio; E. H. Gager, Conneaut, Ohio; N. H. Cooke, W. L. Cooke, T. O. Haydock, Philadelphia, Pa.; H. E. Perret, Milford, Pa.; J. C. Crawford, T. P. Bedilion, Pittsburg, Pa.; H. A. Connell, Scranton, Pa.; C. A. Aughinbaugh, Harrisburg, Pa.; J. Duplain, Boston, Mass.; F. G. Willwerth, So. Boston, Mass.; G. K. Webster, No. Attleboro, Mass.; W. G. Scribner, Waltham, Mass.; F. Schwetzer, Jr., Cambridgeport, Mass.; C. W. Barrows, Middletown, Conn.; F. E. Morgan, New Haven, Conn.; F. P. Davis, Flint, Mich.; L. W. Melchor, Battle Creek, Mich.; J. McK. Everett, G. W. Townley, Sedalia, Mo.; R. Harris, A. D. Prince, Washington, D. C.; R. C. Vogel, J. Fisher, Dallas, Texas; W. M. Purington, Rockland, Me.; P. Hammer-schmidt, Milwaukee, Wis.; E. S. Shewalter, Atchison, Kan.; A. A. Greene, Providence, R. I.; D. Cohn, New Orleans, La.; J. F. Kingan, Staunton, Va.; J. W. Sharrard, Louisville, Ky.; W. J. Farbar, Waterloo, Can.

5 applications were referred.

The Executive Committee have leased for the Jewelers' League the office at 170 Broadway (Room 5) formerly occupied by Hodenpyl, Tunison & Co., and will take possession May 1st, 1884.

### Aristarchius Plumbago and His Bicycle Watch Company.

IN MY last communication to THE JEWELERS' CIRCULAR, injustice was done me through the instrumentality of the red-haired son of Erin whom I had employed in a menial capacity at my embryonic factory at Stoneville. I had commenced writing an

account of the invasion and siege I was undergoing at the hands of the flop-over button brigade when I became mentally prostrated from their importunities and the large quantities of cod-liver oil I had consumed by way of stimulating my nervous energies. Three bottles of this invigorating beverage had I secured for my personal delectation, and to which I had frequent recourse during my interviews with the flop-over button men, and was finally in a most unaccountable manner reduced to a condition of insensibility. It subsequently transpired that the office boy had used the cod-liver oil to grease his hair with, and had filled the empty bottles with a vile decoction of bad whiskey, and this I drank in my bewilderment with the result mentioned. To add to his infamous conduct, that office boy sent off my unfinished letter to THE CIRCULAR, first adding a postscript stating that I had been conveyed to a lunatic asylum. While this might naturally happen to a man who had been besieged by the flop-over button brigade, yet it was not the result in my case. When I fell upon the floor in a state of insensibility a policeman rushed in, hastily placed me in a hand cart and trundled me off to the police court. Here he made the unfounded charge of habitual drunkenness against me, and the magistrate forthwith committed me to an inebriate asylum until such times as my habits should be reformed. Think what an outrage this was! A free and enlightened American citizen, of good moral character, of rare intellect, refined, cultivated, with occasional gleams of transcendent genius, industrious, frugal and abstemious, committed to an inebriate asylum as an habitual drunkard through the devilish machinations of a snub-nose, freckled, Irish office boy with a red head. It was infamous—an act of injustice and persecution for which I should demand redress from the national government were it not for the fact that in the seclusion thus involuntarily forced upon me, I was enabled to mature and put in form some of those grand ideas that have tortured my gigantic intellect for many years, and of which some faint glimmerings have been conveyed to an impatient public in my letters to THE CIRCULAR.

At the asylum I found many congenial spirits—men of almost infinite intelligence—whose brains teemed with rare and philanthropic ideas, to give practical shape to which would be to enfranchise the human race, and lift it to a higher plane of intellectuality and spiritual happiness. Daily intercourse with these incarcerated geniuses gave me renewed hope and courage, and enabled me to give shape and form to many of my own benevolent and industrial plans. These poor imprisoned geniuses were, like myself, confined through a mistake; the world said we were habitual drunkards and must be restrained of our liberties; as a matter of fact we were philosophers, whose ideas were many years in advance of our time; what was regarded by the worldly as beastly intoxication was simply spiritual exaltation; conduct that was deemed evidence of drunkenness was simply the eccentricity of genius manifesting itself in ways incomprehensible to ordinary men. The world did not appreciate us and so placed us under restraint. In the asylum we were treated—Oh! the humiliation of it!—as common drunkards, and efforts were made for our reclamation. Of course, I needed no efforts of this kind, for my habits, with occasional lapses, had always been temperate. Nevertheless, I accepted the treatment in a spirit of investigation and was amply rewarded. I was benefitted by it physically, and also ascertained precisely how much spiritual comfort I can imbibe with safety. There is no danger of my ever becoming a drunkard, for the treatment at the asylum demonstrated the precise amount of cheering beverage I can carry without befogging my intellect or entangling my organs of locomotion. Therefore, I am safe for the future, and if in the past there have been those who distrusted my capacity, they need have no doubts of me hereafter, for I have ascertained to a finger how much I can take without disturbing my equilibrium. Out of evil good sometimes comes, and out of the malicious proclivities of that son of Erin with Skaneateles hued hair, has come to me this knowledge of my capacity, and beyond this limit Aristarchius Plumbago will never pass.

So much in explanation of the past and my long silence; now for the future. I have been released from the asylum as cured; my friends need have no further apprehensions for my future, but may entrust me with their funds with all the confidence of olden times. I now have a practical proposition to submit to them. In THE CIRCULAR of last month there appeared a notice of a new watch movement which you termed the bicycle movement, said to have been invented by some German. You also appeal to me to come to the front and become sponsor for the commercial fortunes of this new discovery. You are in error in attributing this invention to a German—I, Aristarchus Plumbago, am the designer of this movement that is to revolutionize the watch industry of the world. In this colossal brain was the revolution hatched. I had intended to keep the matter a secret for a time, but the ubiquitous press has discovered it; but why you should give credit to a German I do not understand. Probably this was intended as another slap at Chicago, of which wonderfully enterprising city I am now a resident. It is a habit you Eastern men have fallen into of belittling and discrediting everything that originates in Chicago, and I suppose this was another illustration of your petty jealousy; you had rather credit an unknown German with this magnificent invention than give it to a resident of Chicago to whom it rightfully belongs.

But this bicycle movement is, as you justly said, destined to revolutionize the watch making industry of the world. It has but two wheels, a large and small one, so that the term "bicycle" that you applied to it in evident derision is entirely appropriate. With these two wheels, simple as they may seem and impossible as it may appear, this movement accomplishes everything that has ever been accomplished by the most complicated and costly movement. It is a perfect timekeeper, marks the hours, minutes, seconds and eighths, is an accurate stop watch, has a calendar that records the months and days of the year, chimes the hours and quarters, indicates the changes in the moon, records the fluctuations of stocks in Wall street, is a burglar alarm and a fire extinguisher, and, in short, can be applied to almost any useful and necessary purpose. It is an axiom that almost anything can be done by machinery; how to simplify the machinery has been the problem that scientists have puzzled over since the world was formed. The bicycle watch movement cuts the Gordian knot and supplies the long-lost and eagerly sought for missing link that connects mechanical ideas with accomplished results. And this is the fruit of my intellect wrought out in the solitude of an inebriate asylum, with kindly suggestions from my fellow philosophers in confinement.

Having perfected the bicycle movement, the next question that presented itself was how to manufacture them and introduce them to the public. This problem I have also solved. During my involuntary retirement from the gaze of the world, I had an opportunity to study and appreciate the fertility of resources possessed by those who an unfeeling public places under restraint. I perused the statistics of the State prisons, the lunatic and inebriate asylums, the workhouses and all those public institutions misnamed charitable, and I soon became convinced that there is more genius, talent, mechanical skill and general ability, to say nothing of good morals and personal piety, confined within the walls of these retreats than there are outside of them—in short, that the better part of our population is, owing to peculiarities of genius or temperament, restrained of its liberty—that it is to be found, in fact, among prisoners; those who are classified as convicts or as unfortunate incompetents. So I have resolved that the bicycle watch movement shall be made by what is commonly called convict labor. Look at the convicts in our State prisons—who so competent to work in brass as the men who are provided with such an unlimited quantity of it? If you want an escapement, convicts are constantly devising them; they have known all about pinions from the time of their first arrest; while as for cases, they are all hard cases. From every point of view, convict labor is the best that can be found for the production of watch movements and cases. Then, too, as soon as the bicycle movement

is introduced, all the skilled workmen now employed in the various watch factories will be thrown out of employment, and will naturally drift into the workhouses and prisons, so that our labor resources will constantly increase. It will be a simple matter to contract with the different states and municipalities for all the restrained labor we may desire, and this, too, at such low rates as will effectually preclude the possibility of competition. We see daily illustrations of the great wealth accumulated by those contractors who employ convict labor in the manufacture of articles in the sale of which there is great competition; how much more readily wealth can be rolled up when such labor is employed in the production of such an article as the bicycle watch movement, a monopoly, against which there can be no competition.

This is a brief outline of my present scheme. I have the movement that is to drive all others from the field; I have shown where the mechanical labor for its production is to be obtained; the commercial part of the undertaking, selling the goods and handling the funds, I reserve for myself. This is right, of course; being the inventor I should have the manipulation of all money derived from it; stockholders will receive their dividends after the inventor has been properly and satisfactorily compensated. What I now want is a small sum of money to enable me to make contracts for convict labor, buy material and maintain myself in a becoming manner while doing so. I have, therefore, organized a stock company with a capital of \$250,000, one-half to be paid in at once, the remainder to be subject to the call of the president of the company, to which office I have elected myself. Now, here is something for the trade to take hold of; a real, genuine, bona fide-enterprise which they must either control or be ruined by it. When the bicycle watch is once on the market there will be no sale for any others; dealers must have them; it is better for them, therefore, to buy the stock and share the profits of the manufacture than attempt to buck against the inevitable. Shares will be issued of \$100 each—I make them small so as to interest the trade in general—and every dealer buying one or more shares will have special privileges, such privileges to be governed by the amount of stock he buys. If he buys one share and pays \$50 cash, he will have the privilege of buying as many watches complete as he may want at the regular price to retail dealers; if he takes \$500 worth of stock he will be regarded as a jobber, and can have the bicycle watches ten per cent. less than the retail dealer; if he takes \$1,000 of stock he can have the goods at twenty per cent. off prices to retailers. All the stock is for sale; I do not care to retain any for myself, but desire to see the trade reap the benefit of my invention. By the constitution and by-laws of the company the president is made general manager, treasurer and secretary, and these officers constitute the board of directors. The board of directors has elected the perpetual president, so that it is not necessary for me to hold any stock. Shares are now ready to be delivered, and dealers should not miss this opportunity to obtain control of an enterprise that must inevitably revolutionize the watch making industry of the world. I have not yet fixed upon the price to be charged for the bicycle movement, but it will be so low that it will astonish the manufacturers of even the cheapest watches now known. With the bicycle movement made by convict cheap labor, no limit can be placed upon the wealth that may be accumulated by the stockholders in this company. As soon as I have got this company well established, I shall go to Europe for the purpose of introducing the bicycle movement there. In every country of Europe I shall organize a company and utilize convict labor. Here is a new field for the exercise of my genius that has never been carefully worked according to my plan. I only await the sale of a few shares of stock for cash to commence operations. I propose to personally visit retail dealers and verbally demonstrate the advantages they will derive from taking stock in this company. I want every dealer in the country to become interested; if \$250,000 of stock is not enough to go around it can easily be increased at any time; it only involves the cost of paper and printing. I am particularly in need of a small

amount of funds just at present, and, therefore, make this liberal offer; whoever first sends in \$100 for stock in the bicycle watch movement company, shall receive 500 extra shares as a gratuity. This is an opportunity no one should miss while but one person can reap the benefit of it. Who will be the fortunate person to send in the first \$100? Inquiringly and bicycularly yours,

ARISTARCHIUS PLUMBAGO.

P. S.—I forgot to mention that the bicycle movement is particularly well adapted to running a sewing machine, or to act as a governor for a steam engine; it will also do the washing and ironing for a small family, or may be adjusted to rock a cradle or brush flies from the dinner table. It is an exceedingly handy thing to have in the house, besides being the most accurate timekeeper known.

ARISTARCHIUS P.

[Copyright Secured.]

## The Cup—Its Art and Customs.

[BY JOHN W. MILES.]

*Continued from page 39.*

ART, emerging from the torpidity of the "Dark Ages," already presaged a new departure. There was a steady groping after more originality and elegance in the surroundings of life that, like a bud, gave promise of the luxurious blossoming of the 16th century. We may well conceive that articles for the dining room gave the first evidence of this awakening. Next to religious rites refinement has ever clustered around the banquet hall, and betrayed its presence or absence in the utensils and etiquette of the table. Thus we find in the 15th century many attempts towards higher forms of art in this direction, coupled with ingenious and novel appliances, subservient to use. Particularly may be mentioned the portable fountains which graced the middle of the table, and which yielded during the repast various kinds of beverages. Phillip the Good, Duke of Burgundy, had one of these fashioned like a fortress, with towers, supporting human figures; one of a woman yielding hippocras (spiced wine) from her bosom, and that of a child sprinkling perfumed water. For a long time the furniture of the nobles had displayed considerable splendor, born of chivalry and the ceremonious pomp that surrounded knighthood. The nobility has in all ages exhibited more or less of regal magnificence, but the records of the mediæval times give no evidence of these signs of refinement among the middle classes previous to the 14th century. At the time of Frederic II. the domestic provisions of both Italy and France were extremely frugal. The Italian citizen and his wife ate from the same plate, and wooden handled knives were unknown. One or two drinking cups sufficed for each household, and the light used at supper was furnished by a torch held in the hand of a servant. It was an age of simplicity and virtue. The universality of increased refinement and sumptuous living commenced in Italy and France, as in England, at the beginning of the 14th century, and as the wealth of Europe steadily augmented, larger and larger portions of her gold and silver were appropriated for household decoration. The designs were modeled after the prevailing style of architecture, and often highly embellished with rich niello work or with flat reliefs covered with translucent enamel of various hues, which took the place of inlaid gems. The combination of rich colors in the enamel decoration was of the same class as the illuminated manuscripts of the period, the latter remaining to this day marvels of polychromatic art. The houses of the feudal lords particularly were often richly stored with plate of silver, silver gilt and sometimes massive gold. Decoration in niello was especially popular, the great master of the art being Maso Finiguerra. The first known impression upon paper from an engraved metal plate was taken from a pax made by him and before the lines were filled in with enamel. To the 14th and 15th centuries belong also other Italian goldsmiths whose names are familiar to us; Giovanni, della

Robbia, Bonaventura, Ghiberti and many others, led by the acknowledged master of them all, Antonio del Pallaiolo. In the goldsmiths' shops of the middle ages we find the cradle of the fine arts in all the branches which were afterwards developed. Architecture, painting and sculpture received from the goldsmiths' guilds those great artists whose priceless works remain far superior to those of any subsequent century.

Approaching the renaissance it is perhaps well that we should pause a moment and consider the causes of that remarkable revival. Was it owing to an unusual increase of genius at that particular period? Certainly the epoch abounded in brains to design and skill to construct the magnificent and invaluable examples of the art work of the time, but are there not other reasons quite as prominent and without which the glorious renaissance would never have been? Art was under the protection of pope and potentate; kings and noblemen vied with each other in the display of rich and beautiful articles, prized far more for the sentiments they expressed than for the intrinsic value of the materials, however costly. Yet genius and the appreciation of genius would not be able alone to produce those examples that still hold the admiration of the world. It was something more than a revival of art. It was a revival of the study of nature. Here then lies the key of the renaissance. Nature must ever be the source from which true art springs, for, though she is never perfect in any one thing, she is nearly always partially so, reserving for different objects perfection of different parts. The sculptor chooses for his model from one a beautiful hand, from another a well-rounded arm, and, selecting thus his subjects, eventually evolves a Venus, but all the perfections of a Venus or an Apollo never has and never will exist in one living person. But nature must not merely be observed, she must be studied. It requires no special talent to appreciate her beauty, but it is genius that grasps her grand harmonious truths, and, through the alchemy of idealization, returns them to the world spiritualized and perfected.

The 16th century was one of great activity. The conquests of Cortez and Pizarro in Mexico and Peru supplied Spain with vast quantities of gold and silver, while all Europe had acquired more or less material wealth. Printing was invented, and learning, heretofore confined to the priesthood, began to spread among the laity. The literature of Greece and Rome no longer lay buried in written manuscripts, but, placed within the reach of all, was studied with avidity. A fresh world of thought and inspiration was revealed to the rising generation and received with enthusiastic delight. The workmanship of previous generations in the precious metals were relentlessly broken up and remade into the new styles with a zeal forgetful of all sympathy for past skill. It was a period of excitement difficult for us to conceive, and art, having passed the preparatory *quattrocento* stage, was ready to grasp with vigor the new range of thought.

Superior to all other artists in the gold and silver work of the revival stands Benvenuto Cellini. His fondness for this special vocation amounted to a passionate irresistible love that overcame all his own repeated efforts to accept the profession of music desired and urged by his father. He was born in the year 1500 at Florence, and apprenticed when thirteen years old to Michaelagnolo di Giuliano, goldsmith of Pinzi di Monte, who should not be confounded with Michaelagnolo Buonarroti the famous sculptor and one of the few artists of the time who did not begin their illustrious career in the shop of the goldsmith. Cellini remained but a few days in this shop, being taken away by his father, who kept him occupied in the practice of music for two years, when he engaged himself without pay to another goldsmith named Antonio di Sandro. From there we find him at work in many shops of Florence, Pisa, Bologna and Siena. He visited Rome at the age of nineteen, and when, some time after one of his quarrels, which appear to have been numerous, drove him from Florence, he entered the service of Clement VII., making coins and medals. Among the latter he made two of which Vasari says: "To say nothing of the portraits of the Pontiff, which

are so life-like that they seem to breathe, he produced a figure of Peace, who, having bound the Fury War, is burning her arms, on the one side; and with Moses striking the rock from which water is flowing to quench the thirst of his people, on the other; and this work is such that beyond it nothing can be done in that art." He commanded the castle of St. Angelo when the Pontiff was besieged by the Spaniards, exhibiting great courage and stratagetic ability. It was at this time that he took to pieces the jewels of the pope by special command, and melted down the portions which were of gold to pay the pontifical troops. According to his own statement he produced four hundred pounds weight. This transaction resulted afterwards in his imprisonment on an unjust charge of purloining some of the jewels. He remained in the service of the pope fourteen years, visiting Naples, Florence, Venice and other Italian cities, as well as Geneva, Lyons and Paris, at the latter place obtaining an introduction to Francis I. at Fontainebleu. His arrest followed his return to Rome, but upon his release he again went to Paris in the service of Francis. There he remained five years, designing the palace gates at Fontainebleu and numerous other works, but, owing to a disagreement with the Duchess d'Estampes, the king's mistress, obtained permission to return to Italy in 1545. There he worked for that famous patron of the arts, Cosmo dei Medici, in Florence, until his death in 1570. The autobiography of this remarkable man teems with pen pictures of the social and political life of his times, delineated with all the fascinating character of romance.

His works were all of the highest merit, and included a large number of rich and costly cups and vases replete with the symbolism and imagery of the classical Pantheon, a popular theme of all the great contemporary artists. He took special pride in decorating plate with small figures or statuettes executed with all the grace and life of which art was capable. Judging from his own statements nearly all of his work was highly elaborate, preserving in a great measure the classic forms but profusely covered with ornamental details finished with the most careful attention and in artistic unison. Some of these articles must be still extant, but great difficulty is experienced in authenticating them, owing to the absence of marks. All that can be absolutely proven as Cellini's work are a gold salt-cellar, preserved in the Museum of Vienna, one or two medals and one cup of lapis lazuli showing three handles of enameled gold set off with diamonds, and also an enameled gold cover for another cup of rock crystal, kept in the gallery at Florence. In his memoirs he speaks of a chalice, that was designed for the Pope, as follows: "Instead of the boss of the chalice I had made three little figures of a pretty considerable size representing Faith, Hope and Charity; upon the foot of it I represented the stories relative to those figures in three bosses in basso relievo; on one was the nativity of Christ; on another the resurrection; on a third St. Peter crucified with his head downwards—for in that attitude I was ordered to draw him." He tells also of a goblet which he made for the Duchess Eleonore soon after his return to Florence in 1545, and which was enriched not only with chased reliefs but also with full figures. Of course there are many attributions. There is a cup in the Palace of the Uffizi, Florence, of engraved rock crystal mounted in enameled gold and claimed to be his work. Its cover is ornamented with an enamel design strongly moresque and including monograms that were for a long time believed to be those of Henry II. and his mistress, Diana de Poitiers. Recently, however, some have claimed the letters to be not H and D but H and C, the latter designating Henry and Catherine de Medicis, whom he married. A crescent surmounts the cover, where other crescents are found repeated six times in black and white enameling and interlacing with each other. This device was adopted by Henry when Dauphin of France. There are also four cups in the Museum of the Louvre; one of Sicilian jasper, another in Oriental jasper, the third in jasper veined in white and red, and the fourth in green jasper. In one the chalice is fastened to the pilaster with an enameled lock; the second is decorated in enamel with little figures of sirenes, animals, etc. Chased serpent

work forms the handle of the third, while the fourth is not remarkable. Lord Salisbury is in possession of a cup of rock crystal in the form of a ship. The rock crystal is engraved with birds and animals in the midst of foliage. The knop is formed of shells and the foot is fluted. The mounting of the stem, foot, border of the cup and the entire cover is in gold *repoussé* enriched with enamel. The enamel of the cover is translucent green, representing the waves of the sea, in the midst of which fishes, dolphins and marine monsters are sporting. Surmounting the cover is a figure of Neptune armed with his trident and seated upon a large open shell out of which comes a lobster. The design of ornamentation of the knop is remarkable, and also the enamel of the mounting.

Another very beautiful cup of silver gilt and formed something like a chalice is owned by Lord Warwick. The body is ornamented in the middle with a bas-relief representing a furious battle between the warriors of Hannibal and the Roman army. Above and below this are two wide borders of foliage work, separated from the bas-relief by Latin inscriptions. The stem and foot has also decorations of foliage, while sitting around the outer edge of the latter are four satyrs. The Founders' Cup at Emanuel College, Cambridge, figure 39, is of a style so strongly resembling that of Cellini as to be



Founders' Cup at Emanuel College, Oxford, Figure 39.

attributed to him by its owners. The cup itself is of the tazza shape, with a cover overspread with *repoussé* work of fishes, shells and other marine subjects. The interior of the bowl is also filled with *repoussé* work and chasing of marine monsters and nude figures, while the exterior bears shells and shell fish in high relief. The stem is ornamented with a knop embossed with four masks and supporting the feet of harpies whose hands reach the bowl above. The foot, bordered with ornament similar to the "egg and tongue" style, is circular, and decorated in unison with the other work.

The productions of other artists have also disappeared, but there are still enough remaining to give us examples of the rich and beautiful work of the period. By far the larger proportion of these are cups or goblets, which is not surprising if we remember the great quantity that filled the cupboards and sideboards of the nobility. The sideboards of the 16th century, figure 40, were simply a series of receding shelves or steps, the number of which denoted the rank of the master. Persons of royal blood were allowed five, those of the higher nobility four, and so on down to one, which was used by those of gentle descent but without titles. The illustration exhibits the preponderance of drinking vessels over all other articles of plate,



and also shows the "nef" or *navette d'or*. This latter was a kind of case in the form of a ship which held the goblet and some other dishes for the owner's private use. It had a lock, and was an important part of the service of a sovereign or other great person. It was made with masts, shrouds, sails and even sailors in the rigging or



*Sideboard of the 16th Century, Figure 40.*

upon the decks, and was sometimes mounted on wheels. There is one preserved in the Rathhaus of Emden in Hanover from the hull of which wine was drunk. They were among the most costly articles of plate and often richly enameled. Upon both the upper and lower shelf of the sideboard may be seen also the "double" or "trussing" cups, which were made to shut upon the rims of each other. These cups, however, do not exhibit the elaborate and special work of the leading masters of the age.

*(To be Continued.)*

Naval Institute, Washington Branch.

NOVEMBER, 1883.—U. S. N., in the Chair.

*Method of Testing Chronometers at the U. S. Naval Observatory.*

BY LIEUTENANT E. K. MOORE, U. S. N.

*Continued from Page 42.*

THE CONTROLLING circuit leads from one pole of the battery to the binding-screw at the top of the stand, from there through the platinum wire, mercury column, and platinum wire to the other binding-screw; thence to the spools of an electro-magnet placed on the small shelf by the automatic valve, and thence back to the battery.

A condenser, or spark-arrester, is placed in the circuit between the binding-posts of the thermostat.

When in use the platinum wire is adjusted so that the end in the tube indicates the temperature at which the room is to be kept, and the small gas jets are lighted. Suppose the temperature of the room to be below that required, the mercury column will not be in contact with the platinum wire, and the circuit will be open. In this condition the valve will be open, gas flowing and burners burning, which will continue until the temperature rises and closes the circuit by contact between the mercury and platinum; this attracts the armature and closes the valve. This continues until the temperature falls enough to break the circuit, when the same action is repeated.

This is found to work in a very satisfactory manner during the six colder months of the year; the temperature of the room is kept within a range of two degrees, and not unfrequently for forty-eight hours within one degree. By covering the circulating coils with large sheets of close wrapping paper, folded in the middle and

dropped over the pipes, leaving the bottom open, the range of temperature is decreased about one-half.

The table on which the chronometers are placed is circular, and stands in the middle of the room, with the control and automatic thermometers in its center. Each chronometer has a separate compartment, large enough to receive the chronometer and leave a space of an inch or more between its case and the walls of the compartment, each compartment being fitted with a separate lid. Holes are bored in the bottoms of the compartments to allow a free circulation of air, and the lids are left open except at the time of comparing, when they are all closed except that of the chronometer under comparison. The object of this is to permit the comparisons by ear to be made more easily.

A hygrometer is used for testing the moisture in the air, and is left in the room only long enough to determine the daily percentage.

All of the chronometers are compared daily between 11 and 11.40 A. M. with the mean time standard clock, and the errors and rates are worked up every seventh day, called term day; from these mean rates all calculations are made. Comparisons are made to the nearest quarter of a second. The temperature is closely observed each day at comparison and recorded for the previous twenty-four hours, by a chronometric thermometer (a chronometer not compensated for temperature), and by self-registering maximum and minimum thermometers.

All chronometers received, either new, or after having been cleaned and repaired, are placed on trial for six months before their purchase, if new, or before their issue, if old ones. The trials should commence near the middle of summer or the middle of winter in each year, so that the natural temperatures of both the extremes can be used as well as artificial ones.

All chronometers on being placed on trial have the tops of their boxes removed for convenience in comparing, and in order to make them more sensitive to the surrounding temperature. They are examined to see that they fit properly in their gimbals, work perfectly free and without jar, and hang with their faces horizontal.

Some time during the cooler months of their trial, they are placed in the temperature room for about fifty days, during which time they are given two tests at three different temperatures, one set going from a lower to a higher, and the other from a higher to a lower temperature, always beginning with one extreme and ending with the same. By this means the effect of time on the rate is eliminated.

Any three temperatures between 45° and 90° Fahr. may be used, as between these points with the ordinary chronometer the changes of rate, owing to temperature alone, are proportional to the squares of the differences of temperature from the temperature of compensation, or fastest running. Fifty-five, seventy and eighty-five degrees are good temperatures to use, as between these extremes are included all the temperatures through which chronometers will pass in ordinary navigation. These temperatures need not be equidistant, as is the case in Hartnup's method, but may be taken as most convenient.

Suppose we begin this test with 55° as the lowest temperature. The chronometers are placed in the room with the temperature at 52° or 53° for a day or two, when it is raised to 55°, and kept so for a term of seven days; it is then raised slowly to 70° and allowed to remain a day or two at that point before beginning the term at that temperature. After seven comparing days at 70°, the temperature is raised slowly to 85°, and allowed to stand a day or two, and then a seven day term is noted as before. The temperature is then raised to about 90°, allowed to stand a day or two, then lowered to 85°, and the same tests made again, only in reverse order.

Great care must be exercised, especially in lowering the temperature, to keep the hygrometric state of the air in the room about the same, and in no case to allow it to approach saturation. At each change of temperature a day or two is allowed the chronometers in which to settle to their new rates before beginning the term. Some appear too sensitive and overreach themselves, as it were, gradually

falling back; others appear too sluggish, reaching their new rates only after standing a time, while others note the change at once.

In making the second test, the exact temperature used in the first may not be obtained, in which case use the mean of the two temperatures as well as the mean of the two rates for calculations.

All chronometers without auxiliary compensation run fastest at some one temperature, which we shall call the temperature of compensation; this should be the mean temperature to which they will be subjected in actual use, and for navy chronometers it is about 69° Fahr.

The change of rate owing to temperature is least near this point, and increases, the chronometer running slower as the temperature recedes from it. The rate is the same for an equal number of degrees above or below the temperature of compensation. This change of rate is proportional to the square of the number of degrees from the point of compensation, differing for different chronometers. Beyond the limits of about 45° to 90° the change in rate is greater, and proportional to a higher power than the square.

Let  $\theta^o$  be the temperature of compensation;  $r$  the rate at  $\theta^o$ ;  $z$  the temperature constant, or change of rate owing to temperature at one degree from  $\theta$ ;  $\theta'$  any other temperature, and  $r'$  the rate at  $\theta'^o$ .

Then  $r' = r + z(\theta - \theta')^2$  (1), which is the general equation for the effect of temperature alone.

Let  $d, e,$  and  $f$  be the mean temperatures obtained in the temperature room, and  $a, b,$  and  $c$  the mean rates at these temperatures respectively. Then,

$$\begin{aligned} a &= r + z(\theta - d)^2, \\ b &= r + z(\theta - e)^2, \\ c &= r + z(\theta - f)^2. \end{aligned}$$

Whence, 
$$\theta = \frac{(b-c)(d^2 - e^2) - (a-b)(e^2 - f^2)}{2[(a-b)(f-e) - (b-c)(e-d)]} \quad (2)$$

$$z = \frac{(a-b)}{(\theta - d)^2 - (\theta - e)^2} = \frac{(b-c)}{(\theta - e)^2 - (\theta - f)^2} \quad (3)$$

$$r = a - z(\theta - d)^2 = b - z(\theta - e)^2, \quad (4)$$

$$r\bar{n} = r + z(\theta - \theta\bar{n})^2. \quad (5)$$

These quantities differ for every chronometer, but  $\theta$  and  $z$  remain practically constant for the same chronometer as long as its compensation remains unchanged; and the chronometer may go through the hands of its maker, be cleaned, oiled and have minor repairs, and yet these constants remain the same. As a fact, in cleaning and repairing chronometers the makers seldom change the temperature compensation unless it is known to be excessive;  $r$  is variable and changes with time and conditions which will be treated of hereafter.

The first chronometers were placed in the temperature room about February 1, 1883, and the results of some of the best were as follows:

MEAN DATE, Feb. 26, 1883.

No. 729 *Negus*.

Mean temperatures and rates going from a low to a higher temperature:

At 56.1°, rate +0.570s. At 68.0°, rate +0.976s. At 83.1°, rate +0.396s.

Mean temperatures and rates going from a high to a lower temperature:

At 56.5°, rate +0.908s. At 68.6°, rate +1.264s. At 83.5°, rate +0.352s.

Means of the above temperatures and rates:

At 56.3°, rate +0.739s. At 68.3°, rate +1.120s. At 83.3°, rate +0.374s.

Substituting the means in formulæ (2), (3), and (4), and solving:

$$\begin{aligned} a &= +0.739s. & (b-c) &= +0.746s. & d &= 56.3^\circ & (f-\varepsilon) &= 15^\circ \\ b &= +1.120 & (a-b) &= -0.381 & \varepsilon &= 68.3 & (\varepsilon-d) &= 12^\circ \\ c &= +0.374 & & & f &= 83.3 & & \end{aligned}$$

$$\begin{aligned} d^2 &= 3169.69 & \varepsilon^2 &= 4664.89 \\ \varepsilon^2 &= 4664.89 & f^2 &= 6938.89 \end{aligned}$$

$$\begin{aligned} d^2 - \varepsilon^2 &= -1495.20 & (\varepsilon^2 - f^2) &= -2274.00 \\ (b-c) &= +0.746 & (a-b) &= -0.381 \end{aligned}$$

$$\begin{aligned} b-c & \frac{d^2 - \varepsilon^2}{\varepsilon^2 - f^2} = -1115.4192 & (a-b) & \frac{(\varepsilon^2 - f^2)}{(\varepsilon^2 - f^2)} = +866.394 \\ a-b & \frac{(\varepsilon^2 - f^2)}{\varepsilon^2 - f^2} = +866.3940 \\ \text{diff.} &= -1981.8132 \end{aligned}$$

$$\begin{aligned} (a-b) &= -0.381 & (b-c) &= +0.746 \\ (f-\varepsilon) &= +15. & (\varepsilon-d) &= +12. \\ (a-b)(f-\varepsilon) &= -5.715 & (b-c)(\varepsilon-d) &= +8.952 \\ (b-c)(\varepsilon-d) &= +8.952 \\ \text{diff.} &= -14.667 \end{aligned}$$

$$\begin{aligned} -1981.8132 \div -29.334 &= 67.56^\circ = \theta \\ (\theta-d) &= +11.26 & (\theta-d)^2 &= 126.7876 \\ (\theta-\varepsilon) &= -0.74 & (\theta-\varepsilon)^2 &= 0.5476 \\ (a-b) &= -0.381 \div \text{diff.} = +126.24 = -0.00302s. = z \\ (\theta-d)^2 &= 126.7876 \\ z &= -0.00302 \end{aligned}$$

$$a = +0.739s. - \text{prod.} = -0.38289s. = +1.122s. = r$$

$$\begin{aligned} (\theta-\varepsilon) &= -0.74 & (\theta-\varepsilon)^2 &= 0.5476 \\ (\theta-f) &= -15.74 & (\theta-f)^2 &= 247.7476 \\ (b-c) &= +0.746 \div \text{diff.} = -247.2 = -0.00302s. = z \\ (\theta-\varepsilon)^2 &= +0.5476 \\ z &= -0.00302 \\ b &= +1.120s. - \text{prod.} = -0.00165s. = +1.122s. = r. \end{aligned}$$

Substituting the obtained values of  $\theta, z,$  and  $r,$  in formulæ (5), and solving for every 5°, we have:

| Temp. | Rate.    | Temp. | Rate.    | Temp. | Rate.    |
|-------|----------|-------|----------|-------|----------|
| 45°   | -0.414s. | 60°   | +0.950s. | 75°   | +0.944s. |
| 50    | +0.192   | 65    | +1.102   | 80    | +0.653   |
| 55    | +0.646   | 70    | +1.103   | 85    | +0.202   |
|       |          |       |          | 90    | -0.400   |

No. 1220 *Negus*.

Mean temperatures and rates from temperature room:  
At 56.3°, rate +0.175s. At 68.7°, rate +0.464s. At 83.3°, rate -0.201s.  
 $\theta = 67.07^\circ.$   $z = -0.00255s.$   $r = +0.471s.$

| Temp. | Rate.    | Temp. | Rate.    | Temp. | Rate.    |
|-------|----------|-------|----------|-------|----------|
| 45°   | -0.771s. | 65°   | +0.460s. | 85°   | -0.349s. |
| 50    | -0.270   | 70    | +0.449   | 90    | -0.870   |
| 55    | +0.100   | 75    | +0.311   |       |          |
| 60    | +0.334   | 80    | +0.045   |       |          |

MEAN DATE, May 1, 1883.

No. 1059 *Negus*.

Mean temperatures and rates from temperature room:  
At 61.5°, rate -0.658s. At 73.0°, rate -0.642s. At 85.1°, rate -1.175s.  
 $\theta = 67.62^\circ.$   $z = -0.00188s.$   $r = -0.588s.$

| Temp. | Rate.    | Temp. | Rate.    | Temp. | Rate.    |
|-------|----------|-------|----------|-------|----------|
| 45°   | -1.550s. | 65°   | -0.601s. | 85°   | -1.156s. |
| 50    | -1.172   | 70    | -0.599   | 90    | -1.530   |
| 55    | -0.887   | 75    | -0.690   |       |          |
| 60    | -0.697   | 80    | -0.876   |       |          |

No. 221 *Bond*.

Mean temperatures and rates from temperature room:  
At 61.5°, rate -2.096s. At 73.0°, rate -1.820s. At 85.1°, rate -1.765s.  
 $\theta = 81.81^\circ.$   $z = -0.00083s.$   $r = -1.755s.$

| Temp. | Rate.    | Temp. | Rate.    | Temp. | Rate.    |
|-------|----------|-------|----------|-------|----------|
| 45°   | -2.880s. | 65°   | -1.989s. | 85°   | -1.766s. |
| 50    | -2.595   | 70    | -1.871   | 90    | -1.810   |
| 55    | -2.351   | 75    | -1.793   |       |          |
| 60    | -2.150   | 80    | -1.758   |       |          |

No. 505 *Bond*.

Mean temperatures and rates from temperature room:  
At 61.5°, rate +0.626s. At 73°, rate +0.983s. At 85.1°, rate +0.378s.  
 $\theta = 71.77^\circ.$   $z = -0.00343s.$   $r = +0.988s.$

| Temp. | Rate.    | Temp. | Rate.    | Temp. | Rate.    |
|-------|----------|-------|----------|-------|----------|
| 45°   | -1.470s. | 65°   | +0.831s. | 85°   | +0.388s. |
| 50    | -0.637   | 70    | +0.977   | 90    | -0.152   |
| 55    | +0.023   | 75    | +0.952   |       |          |
| 60    | +0.513   | 80    | +0.756   |       |          |

These rates may be tabulated for every  $5^{\circ}$  as above, or if the value of  $z$ , on which the change depends, is large, for every degree. It is, however, more convenient to have them in the form of a curve, from which the rate at any temperature can be taken at a glance.

Take a sheet of profile or other paper, evenly ruled both ways, plate VII. Let the horizontal lines represent degrees, numbered at the left hand, and the vertical lines tenths of seconds, numbered at the top. Draw a distinctive vertical line, say in red, to represent the zero rate, and let all rates to the right be *plus* or gaining, and all to the left be *minus* or losing. Plot the rate for every  $5^{\circ}$  as calculated, by making a dot on the temperature line directly under the rate as shown at the top of the card. Draw a free curve passing through each of these points, or, what is better, bend a spline until it is tangent to each of these points, and rule the curve.

The intersection of this curve with any temperature will be the mean rate for that temperature and is read from the top of the card directly over the intersection.

The position of the zero line will vary with the chronometer, depending on the size and sign of its rate.

(To be Continued.)

## The Goldsmith.

[By JOHANNES PRETZLAFF, Dresden.]

*Continued from Page 46.*

### REFINING THE GOLD-ALLOY BUTTON.

Proceed in the same manner as in cleaning the filing, with this difference, that much more saltpeter must be employed. Should the gold button not become entirely fine with the first working, put it again into a new crucible for another refining.

### ANOTHER WAY; BETWEEN TWO CRUCIBLES.

For this purpose pick out two crucibles, the smaller one of which, when reversed, fits into the mouth of the other one; make a hole in the bottom of the upper one, and after having filled in the granulated alloy button and then filled nearly up to the hole with saltpeter, lute them well together with clay. Apply at first a moderate and then a violent heat. The saltpeter will, during the working, eject the contaminations from the crucible; the falling in of coals is also prevented by this method.

### SMEETING THE STONINGS.

Glow-heat the stonings well and take twice as much flux, consisting of a mixture of 2 parts calcined soda (60 per cent.), and 1 part borax. Do not hurry the work and apply a strong heat for smelting.

### REDUCING-FLUXES.

In order to fuse hard smelting substances such as stonings, bench sweepings, etc., employ a mixture of equal parts of potash, saltpeter and salt; or 3 parts sandiver, 1 part potash and 1 part saltpeter; or 2 parts sandiver and 1 part saltpeter; or 2 parts potash, 1 part saltpeter and 1 part cream of tartar.

### PARTING BY QUARTATION.

After the alloy button has been freed from all base metals by the use of saltpeter, and only gold and silver alone remain, the parting of these metals is begun. This is done either by the wet or the dry way; the former method is the most used.

The proportion of the gold to the silver, in the parting by quartation with nitric acid, is not by any means a matter of chance, at least three times as much silver must be contained in the alloy button; therefore, 1 part gold and three parts silver, since the nitric acid does not work effectively in any other proportion.

When the alloy button has been rolled to a thin sheet, it is cut into small pellets in a glow-heated condition, which are bent or rolled so that they do not lie flat upon each other, but hollow, so that they can be attacked from all sides by the nitric acid. Now, place the mass into the flask and add another like quantity of chemically-pure

nitric acid, and place the flask upon a large sand bath and this upon a very feeble coal fire. After the acid has become saturated and no longer emits bubbles, add another quantity of nitric acid; if this new quantity shows no further reaction the dissolved silver is carefully decanted into glass jars from the brown sedimentary mass lying at the bottom.

The gold is now first freshened by washing with plenty of water, repeating the process until the latter is no longer colored, after which the water is squeezed out from the gold as closely as possible, the latter is dried in air and smelted with borax. If the gold is not entirely dry, take soda or potash for smelting, which absorbs the humidity; in no case, however, try to dry the gold in the sand bath, since it would partially fly off.

### OBTAINING THE SILVER FROM THE SOLUTION.

After the solution has been diluted with about 6 or 8 times as much water, which has already partly been done by the addition of the freshening water, take a clean strong piece of a glow-heated sheet of copper, which has been bent in a roundish shape so that it will stand upright and set it into the solution. The silver will deposit on the copper in handsome crystals, as chloride of silver. The precipitating water is left to stand for 1 or 2 days, and after this time a clean piece of sheet copper is thrown in to be satisfied that all silver has been precipitated; if the silver does no longer deposit pour off the water, and also liberate the chloride of silver from its water by pressing in linen, and after having dried it in air smelt it with borax or soda.

The silver may also be precipitated with salt or muriatic acid, which throws it down in the shape of white flakes as horn silver, when it must be smelted as such.

### SMEETING HORN SILVER.

The precipitate, well dried in air, is, with powdered colophony, placed in layers in the crucible, which must be of such a size that it is more than one-half filled. The crucible having been slowly brought to smelting, and the colophony burnt out, calcined potash is added and a strong heat applied for smelting.

### PARTING BY CONCENTRATED SULPHURIC ACID.

The exact proportion of the gold to the silver is not so scrupulously necessary for this parting. After having prepared the auriferous silver as was described in the parting by quartation, do not use the flask but a suitable vessel of porcelain (where the process is performed repeatedly, platinum or cast iron vessels are preferable), since the concentrated sulphuric acid is raised to a violent ebullition.

When the sulphuric acid has become saturated and the dissolving effected, remove the dissolving vessel from the fire, let it cool, and, for the purpose of clarifying, pour dilute sulphuric acid into the solution. The dissolved silver is next carefully decanted from the gold upon the bottom, another portion of concentrated sulphuric acid is poured in, and the gold is well boiled again, since it will still contain traces of silver; this may be repeated as often as necessary.

The solution poured into the glass jars is well diluted with water, after which the silver is precipitated with copper as above described; it is then freshened with hot water, for which purpose a filter may also be employed, the precipitated silver (sulphate of silver) is pressed out in linen, dried and smelted.

The freshened gold, after being dry, is first smelted with bisulphate of soda, in order to convert the last traces of silver into sulphate of silver, and then smelted with borax and a little saltpeter.

### GRANULATING.

To avoid the trouble of rolling, the alloy button may, by granulating, be reduced into a very fine state of comminution, by pouring it, when smelted, through a broom into a vessel filled with water or else it is poured slowly down a board placed obliquely into water. But granulation is to be used only in the case of parting with sulphuric acid.

### PARTING WITH NITRO-MURIATIC ACID.

This parting would be resorted to if the alloy button were to con-

tain more gold than silver, and the manner of treatment is the same as that with the parting by quartation, excepting that nitro-muriatic acid is used in place of nitric acid. With the nitric and sulphuric acid the silver passes into solution and leaves the gold as residue, while in this instance the proportion is reversed.

When the solution has been decanted, it is diluted with about 8 or 10 times as much warm distilled or rain water, and the gold precipitated by dropping in deliquesced potash, or, what is better, it is thrown down with a solution of protosulphate of iron (green vitriol), which is to be preserved air tight, consequently it must not be oxidized.

After the gold has been well freshened and dried, it is to be smelted, for which take a mixture of equal parts of borax and saltpeter.

#### PARTING GOLD FROM PLATINUM.

Gold containing platinum is dissolved in nitro-muriatic acid, and precipitated from the solution with oxalic acid, while this has no effect upon the dissolved platinum. The latter may, after the solution has been decanted from the precipitated gold, be thrown down with formic acid.

#### RECOVERING GOLD FROM COLORING BATHS.

The collected old coloring baths are poured into a sufficiently large pot, an optional quantity of nitro muriatic acid is added and the pot is set in a warm place, during which time the fluid is stirred with a wooden rod. It is taken from the fire after a while, diluted largely with rain water and filtered through coarse paper. The gold is recovered from the filtered solution with a solution of proto-sulphate of iron (green vitriol), which has been stored in air-tight bottles, freshened with hot water and smelted with borax and a little saltpeter.

#### RECOVERING THE GOLD AND SILVER FROM GOLD LACE.

The laces are boiled in a solution of 16 parts unslaked lime and 8 parts potash. When the silk has been completely dissolved the solution is decanted, and the sediment is well washed before smelting with potash or soda.

#### TEST MARKS OF GOLD.

In order to establish the percentage of a gold alloy as exactly as possible, it is indispensably necessary to procure a hard touchstone either of ground unpolished basalt, black marble or fluor spar. On account of their cheapness those of slate are used most, but they have not the necessary hardness. Next make or buy test needles from 6 to 20 karats; nor is the nitric acid employed a matter of unconcern; take nitric acid which, according to Beck's hydrometer, for from 6 to 12 karat gold weighs 30 degrees, and is entirely free from hydrochloric acid; for from 12 to 16 karat gold, 24 degrees; and for from 16 to 20 karat gold, 40 degrees. To the 24 and 40 graded nitric acid, therefore, for 12 to 16 and 16 to 20 karat gold, a very small quantity of salt is to be added.

If colored or gilt articles are to be tested, scrape the place and pay attention not to take a soldered place.

To prevent equivocations, always make the marks with the gold to be tested larger than those with the test needle, and the marked place of the stone must be fully covered with gold.

Having found the right test needle, the change of color due to the influence of the nitric acid must be uniform, otherwise one of them sooner assumes a darker color. The 14 karat yellow alloyed gold resists for a short time the nitric acid suitable thereto, while the 12 karat gold already changes its color. The 8 karat gold assumes a brown color at once.

For gold above 20 and under 6 karats, this style of testing can no longer be employed.

In order to judge whether the nitric acid exerts the necessary action, and to make the testing still more certain and easy, rule beside the right test needle one of less karats. The attack of the acid, except for inferior gold, must not take place too quickly and strongly.

A touchstone, which is in constant use, is best treated by touching

the marked places with nitro-muriatic acid, and afterward rubbing off with a charcoal and water. The stone, after cleaning, must be rubbed with sweet oil which may be repeated from time to time, since only upon the oiled surface of a stone a uniform mark can be made.

#### CUPELLING TEST OF THE ALLOY BUTTON.

In order to make a close estimation, pieces of the button from above and below are first weighed exactly, after which it is smelted with lead in a muffle or a crucible, with a porous underlay. The lower the percentage of the button, the greater the quantity of lead necessary, which is to be ascertained first by the test marks. Since the quantity operated upon is only small, it is better to employ more lead than is finally necessary; attention must only be paid to having the cupel sufficiently large to accommodate the oxidized lead.

The porous underlay is made by filling the muffle or crucible one-half full with washed wood-ash and bone-ash, equal parts of which have been stirred to a thin paste, and by pressing in with the finger a conical crucible-shaped hole. In smelting the lead absorbs all the base metals, then oxidizes, and vitrifies, and is completely absorbed by the loose cupel. The fine gold and silver remains as a button, which is hammered and rolled to a thin sheet, after which it is dissolved with nitric acid and treated in the manner indicated for parting by quartation and nitro-muriatic acid.

#### SIMPLE METHOD BY THE SPECIFIC WEIGHT.

If the percentage of the alloy button is to be ascertained in an easier way and at the same time with all due accuracy, the most simple manner is by refining the pieces taken from the alloy button after having ascertained their weight; it is next drawn out into a wire which has exactly the same length as that of one from fine silver, and which has been drawn through the same hole. Since the silver is nearly one-half lighter than gold, it is natural that the one of fine silver must be lighter, and the increased weight of the gold charged wire indicates the weight of the gold contained in it.

*(To be Continued.)*

#### Whims of a Bric-a-Brac Collector.

"LOOK HERE," said an old dealer in curiosities, "I have discovered the very latest fraud in this business. For patient ingenuity in the making of fraudulent bric-à-brac the Chinaman surpasses every living thing, unless it be his guileless brother of Japan. Do you see this superb toy? Well, a brother dealer came in here some days ago since in great excitement, bringing this thing with him. He had just bought it, he said, from a collector who was hard up. The dealer knew that the regular price was \$75 to \$100, and jumped at the toy when it was offered to him for \$12. The dealer came to me with his prize to find out if it was all right. A brief examination showed it to be such an amusing fraud that the dealer ran out of my place and has not yet returned.

"The outer shell, you observe, is of ivory, fairly carved and elegantly polished. Put on the magnifier, however, and you will see three or four dark lines running in different directions, but uniting with each other. They show where the ivory has been joined. Pull the joints apart and you will have two very ragged-edged, hollow hemispheres. Originally, as you will see by the grain, these were two thin, flat pieces of ivory. The openings were first stamped out; then the carvings were made, after which the pieces were steamed, pressed into moulds, dried, joined together over the inner balls and then polished. The inside balls are all of compressed ivory made in dies, such as are used for hollow India rubber balls, and the compressing of the ivory shavings, together with the carving, were done at one operation. This is the most ingenious fraud of the kind I ever saw. These things could not have cost more than \$3 or \$4.

"The first question most of my customers ask is, 'Is it antique?' A Brooklyn dealer had a customer on the fence about buying a Waltham watch the other day. The case was battered and the pur-

chaser objected. When told that the movement was modern, but the case was originally made for Queen Henrietta Maria, he bought it at once. I don't know who started the Queen Henrietta dodge, but unprincipled dealers are playing it for all it is worth. People grow tired of Queen Anne and Marie Antoinette, and some change had to be made. When you hear one customer after another remark that if all the articles said to have belonged to Marie Antoinette should be sent to Texas the State would be too crowded to live in, it's about time to start in on another queen.

"By the way, I've got hold of another eccentric collector. He likes any sort of queer bronze figures or groups which represent funny accidents. One of his figures represents a botanist up to his knees in water making a desperate grasp for a rare marine plant with one hand, while he tries to shake off a huge lobster which has fastened itself to the other. Another lobster is exploring his bag of plants, and these troubles are aggravated by the consciousness that his hat is floating down the stream and his spectacles are slipping from his nose. The figure is labeled 'The Problems of Science.' Its companion figure is called 'Absorbed in Literature.' A slim, solemn-looking man, with an umbrella under his arm, is holding a book in which he seems deeply interested, while his right hand grasps a fishing rod which he is holding over a stream. A fish is running away with his hook and line. The artist showed real ingenuity in expressing the fact that the book-worm had been for a long time in his position by putting in an extensive cobweb, which reached from the scholar's hat to the limb of a tree above him.

"A very eccentric group represents a lot of monkeys in the act of chopping off the tail of one of their number. It is labeled 'Fiat Justitia.' The collector insists that his group is a satire on human justice, and that the monkey is suffering the penalty of slander. His ground for the belief is that as the monkey bears a tail he must be a tale bearer, and that in such a case no punishment could be more obviously just than cutting it off.

"One of the groups is more blood-curdling than amusing. An enraged wife has just thrown a drunken husband, who had been beating her, out of the window. He lands on a meat hook which has caught him under the lower jaw. The artist has relieved the ferocity of the figure by causing the man to turn up a pair of very large thumbs in a grotesque manner. A bottle sticking out of his pocket reveals the primary, and a club which has fallen at his side the immediate cause of the tragedy.

"The collector has figures of awkward skaters, grave men who have curled themselves into absurd postures on account of the treacherous banana skin, elderly ladies swept into the arms of fat gentlemen on account of a small hurricane which had filled their umbrellas, men about to attack with stuff clubs the person of the unconscious photographer who has his head covered with the camera cloth, ridiculous-looking dudes trying to avoid mud-splattering ice carts, and various other figures, mostly in bronze, some of them antique, and all of them amusing.

"Another new customer is notable as having a new idea about the arrangement of his collection. Most people either classify their bric-à-brac according to size or kind, or jumble them together without method. This man arranges his collection according to emotional laws, as he describes the matter. He says that an attentive observer of his curiosities may run through the whole gamut of the human soul in forty-five minutes. His purchases are all made with a view to filling some gap in human feeling. His museum is divided into little curtained closets. Each closet is stuffed with bric-à-brac intended to have its special moral effect. The first one contains some pictures of fruit, an ancient punch bowl, three antique Bacchuses with a leer, and a variety of articles intended to represent conviviality. The next compartment contains several Venuses, the mother of Napoleon and of the Gracchi, a large bronze dog, a group of satyrs and other relics in paint, putty, bronze and plaster, which, he thinks, brings out in bold relief the salient features of all styles of love.

"Then he lead me into his Arcadia. It boasts some landscapes, an antique terra cotta of Agricola, a plaque in black clay of Cincinnatus, a farmer in a high hat, and other rubbish of the same sort. This prepared me for his chamber of horrors apartment. It contains a bronze, supposed by the collector to be Judas Iscariot, a series of water colors made from Fox's 'Book of Martyrs,' a modern Quilt in spelter, a set of models of instruments of torture, a barber dentist in bronze of the fourteenth century dragging a negro around with a pair of forceps, a group of frogs fighting a duel, a tiger chewing up a virgin, an engraving of pig sticking in Ireland, and other delightful things which put me in a pleasing frame of mind for the 'happy influences of religion,' as my companion remarked in taking me into the next box. These beneficent influences were shown in the greatest mass of dilapidated idols, joss gods, Osirises and Jupiter Olympuses I ever saw together. I was becoming much depressed, but I stuck it out through eleven cabinets as he called them. Such men make first-class customers, though.

"Business has been a little dull this winter, but we have had some amusement to keep us alive. One of my old customers, another eccentric, brought me recently a two foot statue of the Farnese Hercules, with a request to knock off its head! I knew my man and complied at once. He then told me to dowel the head on again. My son and I drilled the holes and made the peg. But on putting on the head we were told to reverse it; so the Hercules had his face on backward, so to speak. Then the iconoclast pulled a label marked 'Cyprus' out of his pocket, plastered it on Hercules's back and had him sent to his club room. I dare say it made some fun.

"A curious thing in connection with the recent trouble in art circles happened here some days ago. An old collector brought us from his collection every article which had been mended, repaired or restored, and said we must dispose of them for him. I remonstrated, for some of them were choice things. I reminded him that dealers often broke articles and mended them, in order to give an additional flavor of antiquity. He shook his head. People smiled, he said, when they came to a flaw, and always took occasion to ask if the article was genuine or Cypriotic. You see, it hurt his feelings."

---

### A New Pendulum Clock.

THE PENDULUM clock (regulator), constructed by Mr. W. Köllmer, of Vienna, with quarter and hour chiming, presents the novelty that the movement, in spite of its triple functions, is provided with only one winding arrangement, and, therefore, with only one spring in spring propulsion, or one weight in weight clocks, since the striking work is, each one-quarter hour, wound up automatically by the running work.

The accompanying figure, which shows the front plate with minute work, and also the running work of the striking movement, will elucidate the main points of the invention.

The running work of the clock is constructed in the usual manner and is connected with the functions of the striking work only in so far that thereby the star wheel *b*, which effects the winding of the striking work and is fastened to the canon pinion, is revolved once per hour.

The part *a*, to which the quarter and hour rake *l* and *m*, the relieving arm *c*, the rake arm *d* and the movable click *f* are fastened, is lifted by the star wheel *b*, located on the canon pinion, by the relieving arm *c*, once each quarter hour, and, after the drop, actuated by its own weight, but hindered by the warning wheels *g h i* and the fly *k*, sinks slowly upon the snail.

In the lifting of the part *a* the easily-springing click *f* slides upon the finely-toothed *g*, and, by the falling of the part *a*, sets it into motion by catching in the teeth and impelling the wheel in this manner. Wheel *g* seizes in the warning wheel *h*, and this again in the warning wheel *i*, which latter finally revolves the fly *k*. During the

sinking down of the part *a* the teeth of the quarter and hour rake *l* and *m* propel the quarter and hour hammer *n* and *o* as often and long as necessary, until the rake arm fastened to the part *a* strikes upon the hour snail *e*. In the cut the movement is about to strike the full hour, whereby the quarter-hour hammer *n* has already passed the teeth of the quarter rake *l*.

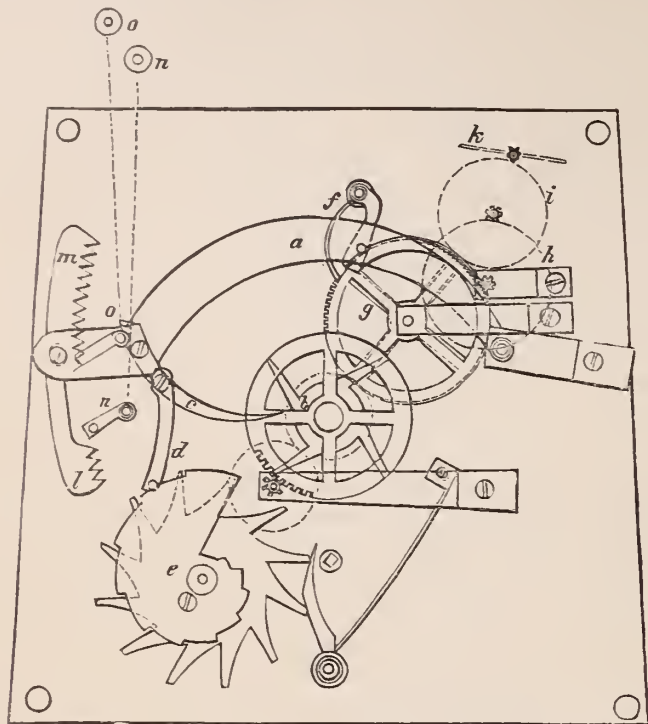

In order to optionally increase or decrease the motive power for the striking work, the part *a* may still be prolonged beyond the rake by an arm with slidabie weight, which has not been represented in the sketch, however.

We have practically tested a pattern of above described clock for a length of time, and have become fully satisfied that the mechanism performs to full satisfaction if constructed with the indispensably necessary exactness. The running work must be constructed more substantial than is necessary for the ordinary regulators, and be provided with a much stronger spring or heavier weight, since it is charged with the function of lifting the rather heavy part *a*, to which the quarter and hour rake is fastened, every quarter hour. Although the full motive power operates upon the running work for a few minutes after the drop of the relieving arm *c*, until the lifting of the part *a* re-commences, we were unable to detect a noticeable increase in the amplitude of the pendulum oscillations; on the contrary, the rate proved to be fully as good as that of the better class of regulators.—[*Deutsche Uhrm. Ztg.*]

### A New Sun Dial.

WATCHMAKERS who live at a distance from observatories or standard time are frequently at a loss for correct time; this want, according to the notice in the *Revue Chronométrique*, has been supplied by the invention of a new solar regulator by H. Cornelloup, Paris.

The following description of the instrument will, with the assistance of the accompanying cut, of about one-half size, be easily understood.

Upon a pillar, resting upon a square solid base, is a support which has its extremities bent at right angles, and which revolve and around a common center of motion, and on a center at which ends the apex of a graduated sector. This latter indicates the different degrees of the inclination of the double angle. Underneath it is located a drum provided with a dial and hand. This inclination

must always coincide with the latitude of the place. When the sector has been placed at the right point it is fastened with a set-screw.

The style and the plate upon which the noon line is traced are independent. The plate pivots between the two upturned extremities of the support. Upon the prolongation of the lower pivot, which enters the dial case, there is adjusted a pinion, which, through the intermedium of wheel work, causes the hands to revolve. A compass fixed on the base of the apparatus serves to place it in proper position. The instrument is regulated when the aperture in the style, the solar noon line and noon as shown by the hands on the dial are

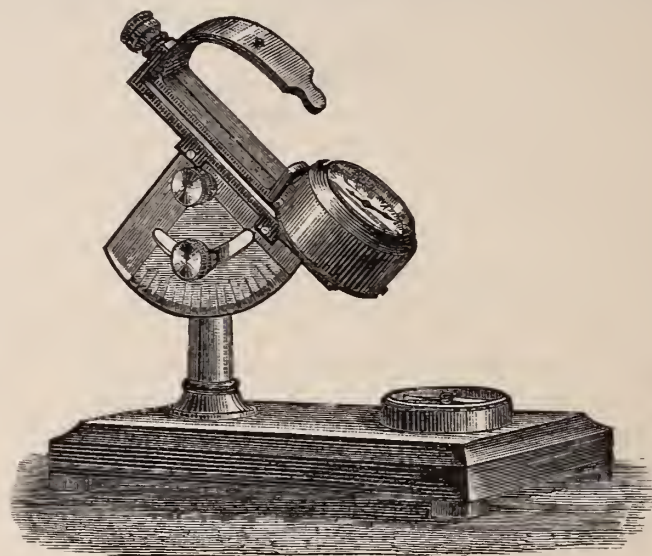

exactly in the same vertical plane. The instrument having been regulated, it will be only necessary to incline the style to the right or left so as to bring the luminous point upon the noon line; and, as the hands will follow its motion, the hour will be read upon the dial. While traveling, the owner may regulate the apparatus by the aid of a good watch, having seconds hands, which has been set by observatory time, or by the aid of a good chronometer. The instructions that accompany the instrument indicate the inclination to be given the sector to make it correspond with the latitude. What will bring this apparatus into use, especially with amateurs, is the fact that, unlike the sun dial, which is always fixed, it may easily change place, and the hour be read upon it just as is done with the watch.

### Practical Treatise on the Adjustment of a Four-Jewel Cylinder Watch.

[First-Prize Essay by HERMANN HORRMANN.]

Continued from page 41.

#### CHAPTER XIII.

##### THE CORRECTION OF THE DEPTHINGS.

157. Having bushed the lower fourth wheel hole upon the center, (Art. 142 to 145), this wheel, together with the cylinder scape wheel, is mounted and inspected whether the depthing has been disarranged by the bushing. If it is true, investigate well whether the wheel sits straight; if this is not the case it must at once be uprighted.

158. The previously described method for bushing the holes is useful if the depthing stands well in the plate. It is otherwise, however, if it be either too shallow or so deep that by the rounding of the wheel upon the engine the wheel rim becomes too small whereby, the good appearance of the wheel and also its division is likely to be deteriorated.

159. It becomes necessary in these cases to adjust the depthing by means of the depthing tool.

For this purpose both holes of the fourth wheel are closed with screwed in bouchons, the cylinder wheel is set to the left, the fourth wheel between the right centers of the depthing tool, if this stands

in such a manner that its set screw is to the right. It is next set correctly by means of this screw, and with the opening of the tool (without touching the set screw), from the pivot hole of the cylinder wheel a fine circle is struck upon the inner side of the recess for the fourth wheel, whereby great attention must be paid to holding the depthing tool at right angles to the plate. Truly upon this circular line, although as nearly in the center of the recess as possible, so that the fourth wheel be not shifted too far from its place, the hole to be drilled is marked on, it is then drilled through in the previously described manner, and next uprighted upon the upper bridge.

Before displacing a fourth wheel, pay attention to the following four points: 1. The opening for the seconds hand in the dial, if the watch is provided with one, as is generally the case at present. 2. The distance of the balance or of the banking pin from the shaft or the pinion of the fourth wheel. 3. The interval of the points of the cylinder scape wheel and the leaves of the fourth pinion; and, finally, 4. The position of the third wheel depthing; this is attended to last, and by which, therefore, this depthing is to be set (see Art. 165 to 167).

160. A depthing regulated in this manner can never be considered good until it has been examined in the plate, since circumstances may occur that it was not transferred to the watch as it stood in the depthing tool. When the depthing stands really good, the wheel shake is regulated, which can often be done by raising or lowering the bridge. This, however, can only be done in exceptional cases by the raising of burr (see Art. 136).

161. If only little is required to create sufficient end shake, it is oftentimes quickly effected by filing the bridge, if sufficiently thick, somewhat thinner, or else by bending the bridge a little (compare Art. 136). It is better, however, if little pins are drilled in the bridge, which protrude as much as necessary, in accordance with whether the shake is to be increased or decreased. Should this quantity be too much, however, or if the arbor is decidedly too long, the pivot is to be corrected.

162. According to circumstances and the height of the wheels to each other, it will also be frequently necessary by sinking out upon the bottom of the plate or by a somewhat projecting bouchon, to regulate the shake from below. But attention must be paid to that fourth wheel do not move too close upon the bottom, because the dust falling in deposits itself there preferably, and might easily produce a stoppage of the wheel. It is necessary, therefore, to always provide sufficient room by turning out upon the universal lathe.

163. With very ordinary watches with soft pinions it happens that the cylinder scape pinion, by the riveting of the wheel, is riveted down below on its facet, and that there is burr in the pinion; this is to be removed before the investigation of the depthing. With insufficiently deep spaces in the cylinder scape pinion, extra care is necessary that the points of the fourth wheel teeth do not strike upon the bottom of the spaces of the pinion leaves. It is commendable, therefore, to round especially this wheel with an Ingold fraise, or in case none is on hand, to remove the unnecessary burr on the points of the teeth in the turning lathe by holding an oilstone against them; no faces must be ground on them, however. As previously remarked, plenty of tooth shake with this depthing is to be recommended (see Art. 102).

164. After having become fully satisfied that this depthing passes through easily and correctly, and has sufficient tooth shake everywhere (Art. 102), that the fourth wheel has sufficient end shake, does not cramp and moves completely free in its recess, the cylinder wheel is taken out of the plate and the third wheel is mounted.

#### CHAPTER XIV.

##### THE THIRD WHEEL.

165. In a watch, the fourth wheel depthing of which has already been regulated, that of the third wheel will hardly have remained true; if it should have come out of truth, it becomes necessary to regulate it, and for this purpose the two third wheel holes are first provided with screwed-in bouchons (see Art. 158 to 160).

166. First, the depthing of the center wheel, which is inserted upon a turning arbor, is, together with the third wheel, placed into the depthing tool. When the depthing has therein been set true, both wheels are taken out, and, without touching the set screw, the points are set thus that the tool stands vertical when the circular line is drawn (see Art. 159). In the same manner place also the depthing of the third wheel in the fourth wheel in, and also here strike a circle. Upon the point of intersection of both will be found the center of motion of the third wheel.

167. When the lower hole has been drilled, the upper uprighted and also drilled, the two pivots are polished, rounded off and the holes suitably broached. As long as the pivot does not yet fit, it is well to screw the bridge upon the plate, and to let the broach pass through the two pivot holes when broaching, whereby the holes must become truly straight.

168. When the pivots fit above and below in the holes, the bridge is unscrewed and broached additionally from within so that the pivot have the necessary shake in the hole. The oil sinks are made next, and the necessary end shake is provided.

169. Any rough filing strokes underneath the bridge are to be removed by grinding with a water stone or by treating with a smoothing file.

It is often found that the bridge has been smoothed with an emery file; this, however, should never be used for the purpose. It is possible that very small grains of the emery are pressed into the brass and remain in it in cleaning, which is followed by the rapid wear of the shoulder or pivot. Use emery only where it belongs, that is, for the working of hard steel, etc. (see also Art. 174).

To keep from injuring the gilding of these parts in the filing or grinding, a new clean piece of cork is fastened in the vise, a clean, soft linen rag laid upon it, and after a few strokes have been made, the underlay is constantly renewed by taking a new place of the rag.

It looks well if the edges of the faces under the different bridges are nicely taken off and treated with a burnisher. This, of course, merely contributes to the good appearance of the watch but not to its services.

170. The burr is next to be removed out of each hole, this is then cleaned with the pegwood and the wheel is mounted; the latter is caused to revolve in various positions and examined whether it move freely and without cramping.

171. It is very frequently necessary, when the depthings have been mounted, that the plate must be corrected by turning, because the wheel had to be set out of the center and now scrapes on the sink. The upper face of the third wheel not unfrequently scrapes on the foot of its own bridge or on that of the center wheel, and room must be made by filing. Should the center wheel be very high and scrape on the third wheel bridge, the place below the bridge is filed free a little and rounded off.

When all these jobs have been performed with exactitude and attention, the depthings, and, in fact, the entire train, will be in good order and serviceable condition.

172. It is not necessary for every adjustment that all depthings are to be set with the depthing tool; many a watchmaker employs it only when the depthing stands really too shallow. If the holes and pivots are good otherwise, or that the wheel sits straight and the depthing is too deep, recourse can be had to rounding the wheel smaller. But great care must be paid not to produce a disproportion of wheel and pinion, since the latter becomes proportionately greater thereby; be careful, also, not to injure the appearance of the wheel by too small a tooth rim.

173. Many skillful and experienced repairers do not, in the adjustment, bush every small hole if the depthings are right; they say that the metal of the plate or bridge, and the gilding in them is fully as good and frequently much better than that of the bouchons inserted. The plate, however, must be sufficiently thick that the pivot just protrudes beyond it; the hole must be drilled straight, and on the inside be free from burr and loose particles of gilding which would jeopardize the pivots and accelerate their wearing down. It is to be recommended, therefore, to press the burr and gilding in the holes hard and smooth with a good smoothing broach. If the hole becomes too large thereby it must unconditionally be bushed.

(To be Continued.)

## Electric Clock.

[Patented in Germany by A. EGTS, Burhave.]

HAVING BEEN solicited by various parties to give a description, illustrated by drawings, of the electric clock with seconds pendulum, constructed by me, I comply with their solicitations. Before doing so, however, I would state that I did not design to construct a clock for astronomical purposes, but I simply essayed to manufacture a useful, reliable and cheap regulator for the regulating of a number of clocks, both for the services of my colleagues and myself. It is very well known that the ordinary weight regulators often give rise to vexations, be it either by reason of neglect to wind them, or by reading the time incorrectly, since the different positions to the minute hand of the regulator which the operator assumes in regulating, easily give rise to equivocations, especially if the minute hand moves at a distance from the dial.

At the same time I sought to solve the problem of constructing a cheap and serviceable show-window timepiece, without interfering with the standard clock, and to bring the former into accord with the latter, and to dispense with the frequently disagreeable winding and setting of the window timepiece. How far I have succeeded in my endeavor of constructing a timepiece complying with these requisites, I leave to the judgment of my brother watchmakers.

The seconds pendulum *a* (fig. 1), is suspended from a double spring *b*, which is composed of 2 pieces spring steel *b*<sup>1</sup> *b*<sup>1</sup>, 4 small ivory plates *c c* and 4 small brass plates *d d*. The springs, therefore, are insulated from each other by the ivory plates; with the brass plates, however, they are united to form a conduit, by means of rivets and the protruding pins *e e*. In front upon the wooden pendulum rod (fig. 1), is the brass piece *f* (at the same time the front suspension hook, is screwed on, which ends below in the spring *g* with the milled screw *g*<sup>1</sup>. Behind on the pendulum rod another such a piece, the rear suspension hook *i* (fig. 2) is screwed on, so that the two hooks are insulated from each other by the pendulum rod, but by supposing the pins *e e* with the springs *b*<sup>1</sup> *b*<sup>1</sup>, they are brought into a conducting union, however.

By means of the bolt *h*<sup>1</sup>, *i* is brought into a conducting connection with the anchor *k* (figs. 1 and 2), which carries the feeble spring *l*.

An insulating piece *f*<sup>1</sup>, located on the anchor, supports the spring *g*. Upon the bridge, behind which the pendulum freely oscillates, the wheel *o*, with 30 pins, is mounted upon a long and thin staff in such a manner that it can easily revolve, and by the oscillations of the pendulum it is alternately propelled by the wedge-shaped jewel pallets *o*<sup>1</sup> *o*<sup>1</sup> of the anchor, which is firmly united with the pendulum,

which is effected with a very trifling friction and little loss of power. A conduit wire passes from the battery to the front pendulum

spring, and another such a wire passes from the back spring to the electro magnet *p*, and another one goes from here back to the battery. When, now, the wheel *o* has been pushed round so far that by the inclination of the pendulum toward the left, the pin situated on the spring *l* locates itself to the jewel *h*, *l* inclines backward and places itself with its platinum-soldered face against the platinum point of the milled screw *g*<sup>1</sup>, whereby also the spring *g* is raised by a trifle and the circuit is closed. This now passes from the battery through the front suspension spring, the front suspension hook, the spring *g* and milled screw *g*<sup>1</sup>, back through the spring *l*, the anchor, the bolt, the rear suspension hook and rear suspension spring to the electro-magnet, and from hence to the battery.

The current is closed at the moment when the pivot of the cone *s* is at the pivot *x*, the electro-magnet is hereby induced, the anchor *y* together with the impulse lever *r* connected with it is attracted, and the coil spring *r l* tightened. The cone *s* is raised by a trifle, until *r* has passed, lets it drop and comes to a rest in the direction of the dotted line to the left, and thus permits the cone *s* to oscillate above it.

By the return motion of the pendulum, when the point of the cone *s* has arrived again at *x*, the current is interrupted, the lever is liberated, applies itself attracted by the coil spring against cone *s*, and, lifting this a little, with a gentle pressure conducts the pendulum to the right where it drops, and comes to a stand-still in the dotted line until the next closing of the current. Owing to the fact that the cone *s* follows the circular motion of the impulse lever, the friction is at this place almost reduced to nothing.

Since the contact is established only every 60 seconds, and then only for the fraction of a second, the consumption of electricity is exceedingly small. In consequence of this, the clock may advantageously be impelled with manganese elements, which remains constant from 1½ to 2 years.

The spring *g* possesses a certain power of resistance, so that the current is closed with sufficient power, while the irregularities which can arise by an insufficient closing of contact are obviated, especially since the position of the springs to each other is that of an acute angle, whereby the points of contact are retained bright, that is, as is the case here if the closing of the contact ensues with sufficient force.

The wheel *c*, which is composed of aluminum bronze, and, therefore, is very light, carries upon its long canon (internally lined with ivory), upon its front end a light, well-equipoised steel hand, which, upon its own dial, shows seconds. Fig. 4 shows the arrangement of the dials.

At an appropriate distance, farther down below, a second bridge is mounted with screws, which on fixed pivots carries a minute work, upon the canon pinion of which is riveted a light wheel with 60 pins.

The second arm of the anchor on the electro-magnet by means of an ivory cone, at each closing of the current, pushes this wheel by one pin forward, whereby springing minutes are produced.

The cone *u* protects the wheel *o* against a return motion, by gently bracing itself, by reason of its small weight, against the disc *v* surrounded with an india rubber ring.

The arm *z* prevents that at the closing of the current more than one tooth is propelled forward,

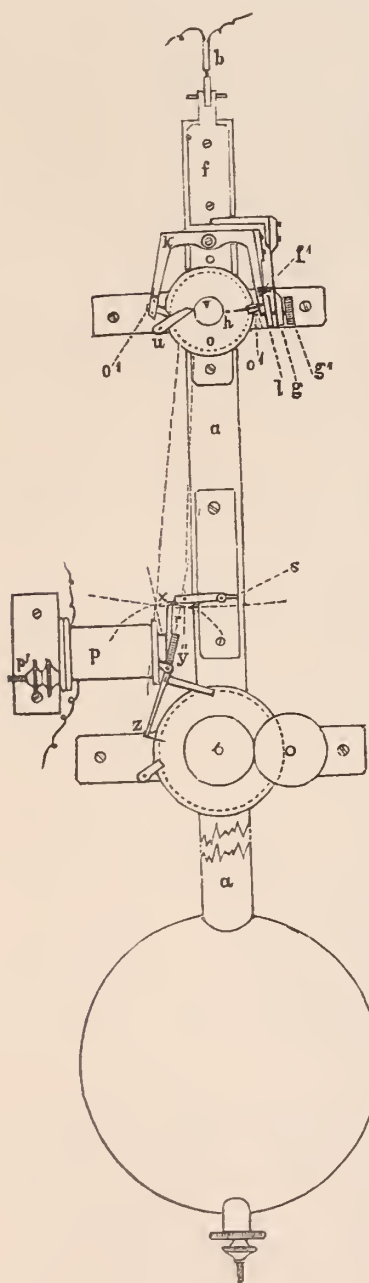

FIG. 1.

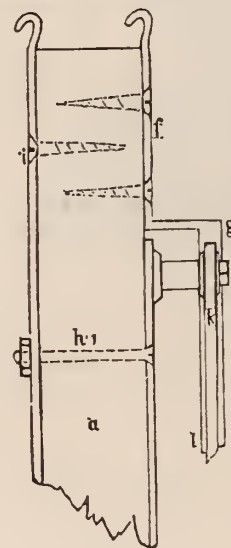
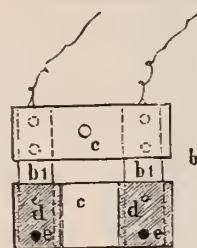

FIG. 2.

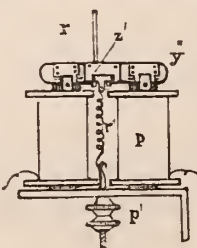

FIG. 3.



By means of the nut  $p^1$ , the tension of the coil spring and thereby the force of the pendulum impulse is regulated, so that it remains uniform during all the variations of the current.

The only function of the pendulum, therefore, consists in that it propels the light wheel by means of the wedge-shaped pallets, because the force necessary for the tension of the contact spring can hardly be taken into account since they restore the force necessary for their tension to the pendulum in its return motion.

In fig. 3 the electro magnet is represented as seen from below, in order to show the motion of the anchor and the situation and operation of the coil spring.

The anchor moves like a hinge in two brass parts screwed to the poles of the magnet in which ivory linings are inserted, so as to dispense also here with the oil.

The brass piece  $z^1$  screwed upon the anchor has a pronged projection with two notches, in which rests a piece of steel with double edges; the coil spring is hooked in its lower end, whereby the friction is reduced to a minimum at this part.

It is almost unnecessary to say that the spring must operate as near to the center of motion of the anchor as possible, since its effectiveness becomes more uniform thereby.

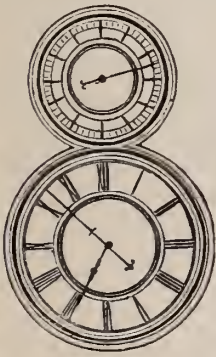

FIG. 4.

The pressure of the impulse lever against the cone need to be very small only in consequence of the great freedom of the pendulum, and by a casual observation it would barely be believed that so small a force is capable to sustain such a pendulum in motion for one entire minute. How exceedingly small the power lost by the revolution of the fourth wheel is can be seen by the fact that if by a normal oscillation of about 3 degrees the battery is disconnected, the fourth wheel is still propelled for from 15 to 18 minutes before it stands still; the bob weighs only 2 pounds.

The advantages of my electric clock according to the experiments instituted with it, can, therefore, be summed up as follows:

1. The pendulum possesses the greatest possible freedom.
  2. The contact is closed with fully sufficient power, without influencing the clock itself.
  3. The clock can be manufactured very easily and cheaply since it neither requires plates, pinions (except the minute work), nor mainsprings, clicks, etc.; besides this, in consequence of its great simplicity and small friction, it will hardly ever require any repairs of importance.
  4. The clock requires no oil, and cannot, therefore, be influenced by its injurious properties.
  5. The rate of the clock is perfectly independent of all irregularities of the current.
  6. Its style of construction admits of a special dial for showing seconds—an advantage not to be underrated for the purpose of regulating timepieces.
  7. The seconds hand harmonizes without further trouble with the minute hand, after setting the latter.
  8. In consequence of the closing of the current occurring at great intervals, the clock can be propelled with a battery which remains constant for  $1\frac{1}{2}$  or 2 years; besides this the latter is also provided with an arrangement by which attendance upon it during this length of time is dispensed with.
  9. The minute work is propelled with the full force of the current.
  10. No wire conduits are necessary as long as no dummy clocks are to be connected with it.
  11. Finally, several other dummy clocks may be impelled by this, without its being interfered with in the least.
- (The contact is in such a case by the anchor of the electro-magnet).—*Deutsche Uhrmacher Zeitung*.

## Proceedings of the Horological Club.

### A DISTINGUISHED BODY OF WATCH AND CLOCK MAKERS.

*One hundred and eighteenth discussion.—Communicated by the Secretary.*

[NOTICE.—Correspondents should write all letters intended for the Club separate from any other business matters, and headed "Secretary of the Horological Club." Direct the envelope to D. H. Hopkinson, Esq. Write only on one side of the paper, state the points briefly, mail as early as possible, as it must be received here not later than the eighth day of the month, in order to be discussed and reported in the CIRCULAR for the next month.

#### MUNGER'S METHOD OF ADJUSTING CHRONOMETER ESCAPEMENTS.

Mr. Ruby Pin then called the attention of the club to a new method of securing the proper relative position or adjustment of the several members of a chronometer escapement when in the course of manufacture they are first assembled, so as to avoid the usual difficulty in properly locating the pivot holes. It consists in constructing the detent of a maximum or excessive length to start with, then mounting the members of the escapement in approximately correct positions, and finally securing the exact adjustment by simply reducing the length of the detent till it permits the parts to assume the exact relative positions required. The reduction of the detent can be effected by hand tools, or by any other convenient means, but a special device for that purpose is also shown by the inventor, Mr. L. F. Munger, of Rochester, N. Y., who has recently covered these inventions by patent. It certainly seems a very simple and easy way to obtain the adjustment, and, as the inventor claims, enables him to construct timekeepers possessing the excellent timekeeping qualities of the chronometer as cheaply as the ordinary timekeepers can be produced. Those interested can probably obtain all desired information by addressing Mr. M. at Rochester.

#### HOW TO HARDEN STEEL WITHOUT SCALING.

*Secretary of Horological Club:*

I have a great deal of trouble in hardening small polished steel work. It scales, and that destroys the polish. Please inform me how I can do it and not discolor the same. C. R. H.

Mr. McFuzee replied that the "scale" is caused by exposure of the steel to air while heated, thus oxidizing the surface. The only way to prevent this is to protect it from air. Some workmen warm the piece enough to melt common soap and give it a coating of soap, then wrap it in thin metal or foil of some kind while heating, and throw the whole into the water to cool it. Others take a metal tube, a clock key, clay pipe bowl or other piece having a suitable cavity in it, arrange a loose cover in it, as a piece of battery carbon cut to proper shape, then put the piece to be hardened into the cavity, pack around it with fine charcoal dust, lay on the cover, heat up to cherry red throughout, then empty the contents into the quenching bath, taking care to hold it as near the water as possible so that the piece will have the slightest exposure to air on the way to the water. Other ways are employed, but everyone can study out a good one for himself when he understands what it is that he should avoid, *i. e.*, the exposure to air.

#### HOROLOGICAL LITERATURE.

*Secretary of Horological Club:*

Allow me to express a thought or two about THE CIRCULAR in a candid manner. I have been a subscriber to and a reader of scientific journals for upwards of thirty years, and I do not think that the money and time so expended has been in any way to my disadvantage.

Every young man who aspires to eminence in his chosen profession should devote more or less of his spare time in consulting the best available text books and serials relating to such profession, and I know of no better serial at present than THE CIRCULAR for watchmakers and their apprentices.

I think that if watchmakers would supply their apprentices gratuitously with such a publication during their terms of apprenticeship, the increased facilities of the apprentices for obtaining practical and theoretical knowledge would be so much appreciated by the recipients that the donors would be amply rewarded, not only for

doing good deeds, but by having more cheerfully performed and better workmanship as a result of their kindness; for I know from experience that frequently a single number of your journal contains practical information on some one subject, that is of more value than a whole year's subscription.

E. H.

Mr. Clerkenwell said he thoroughly agreed with our correspondent, and that the members of the club had frequently urged our readers to supply their apprentices and workmen with good horological literature, both in periodicals and books. Most of the European works of any value are soon translated and published in THE CIRCULAR, except Saunier's great work on "Modern Horology," which is much too extended to admit of insertion. Another well-known standard work "The Practical Treatise on the Balance Spring," by Excelsior, originally appeared in THE CIRCULAR. So our correspondent is evidently justified in his high opinion of that journal, as being unquestionably the best periodical in the trade for the instruction of workmen and apprentices, and furnishing the best and latest information on every point which they require to understand.

## SHOULD WORKMEN OR APPRENTICES WORK NIGHTS?

## Secretary of Horological Club:

Is it customary or duty for a workman or apprentice to work at night?

S. A. K.

Mr. Uhrmacher replied that it would naturally be understood that a journeyman or apprentice would conform to the customs of the locality. If it was customary there to work at night, the proprietor might reasonably expect it to be done in the absence of any agreement or understanding on that point. If the workman does not feel disposed to work evenings, he should make some inquiry as to what was expected, or should have it clearly understood in the contract of employment. He thought it was customary in most country places for the watchmaker to be in the shop evenings, and do whatever could not be postponed, talk to the customers, etc., but not to "work" in the regular way. In the cities it is equally customary for the workman to have his appointed hours, and then to "quit" like workmen in other trades. In both city and country an apprentice is generally expected to be in the store evenings. But, as already observed, any trouble can be avoided by having a distinct understanding at the time of making the bargain with the employer.

## History of the Chicago Relief Fund.

IN OCTOBER, 1871, there was subscribed by the "down-town jewelers and other kindred trades" \$13,865 for the relief of the sufferers in those trades from the Chicago fire, Robert Schell being treasurer of the fund. The greater portion of the money was forwarded to Chicago for distribution through a committee of the trade in that city. In December, 1873, Mr. N. Matson, chairman of the Chicago committee, reported that they had relieved all cases of distress among the trade, and had no use for the balance in their hands or in the hands of Robt. Schell in N. Y. On April 10th, 1874, a meeting of the original subscribers to the fund was held at the Astor House to determine what should be done with the balance then remaining. It was decided to place it in the hands of Wm. Ruhl (since deceased), Henry Randel and Enos Richardson as trustees, to receive and invest what remained unexpended, and hold it for "any future calamity that might occur in the jewelry and kindred trades, subject to the approval of the subscribers to the original fund." The above-named trustees accepted the trust, and elected Enos Richardson treasurer, who received from N. Matson and Robt. Schell the money in their hands amounting to \$5,396.88, which was invested in bonds. During 1881-2, the Jewelers' League, having obtained from many of the original subscribers assignments of their interests in the fund, a demand was made for their portion of it for the benefit of the League. As the trustees of the fund could be legally relieved from the trust only by suit, a friendly suit for that purpose was commenced July 1st, 1882, by Gilbert T. Wogloom, as trustee for the Jewelers' League, against Henry Randel

and Enos Richardson, as surviving trustees of the Chicago Relief Fund for a distribution of same. On December 10th, 1883 Judge Donohue of the N. Y. Supreme Court, gave an order that after the payment of certain sums granted by the court as expenses, the balance should be divided *pro rata* to such of the subscribers as had proved their claims. On Dec. 19th, 1883, the securities of the fund were sold at auction and realized \$10,864.34, which, together with \$782.25, cash on hand, made a total of \$11,646.59 realized. The amount of the awards being paid there remained in the hands of the trustees \$3,082.98. As quite a number of the original subscribers had neither proved their claims nor assigned them to the Jewelers' League, the trustees during January and February of the present year sent notices to such of them as could be found, requesting them to prove their claims. A greater portion of them have done so—without expense to them—and on March 12, 1884, Judge Donohue granted another order to pay those their *pro rata* share. There still remains in the hands of the trustees after paying these latter subscriptions, \$1,491.35, from which any of the original subscribers can receive their portion, without expense, by proving their claims.

Below we give full statement of the fund and its disposition.

| 1874.  |             | RECEIPTS.      |             |
|--|-------------|----------------|-------------|
| Original amount received from N. Matson and R. Schell in 1874,   | \$5,396.88, |                |             |
| which, with accumulated interest, amounted on  |             |                |             |
| 1883.  |             |                |             |
| Dec. 19th, Cash on hand—not invested.....  | \$ 782.25   |                |             |
| Sale of securities....   | 10,864.34   |                |             |
|  |             |                | \$11,646.59 |
| 1883.  |             | DISBURSEMENTS. |             |
| Dec. 22d, Payments made as per order of Judge Donohue,   |             |                |             |
| Dec. 10th, 1883:   |             |                |             |
| To Henry Randel and Enos Richardson for trustees' commissions.....   | \$ 292.25   |                |             |
| To G. A. Miller, attorney for the Jewelers' League, for costs assessed by the court.....   | 616.22      |                |             |
| To G. A. Miller, attorney for Jewelers' League, for legal services allowed by the court.....   | 500.00      |                |             |
| To Butler, Stillman & Hubbard, attorneys for Enos Richardson, trustee, for costs assessed by the court.....  | 75.95       |                |             |
| To Butler, Stillman & Hubbard, attorneys for Enos Richardson, trustee, for legal services allowed by the court.....                                | 300.00      |                |             |
| To Robt. Benner, attorney for Henry Randel, trustee, for costs assessed by the court.....  | 75.95       |                |             |
| To Robt. Benner, attorney for Henry Randel, trustee, for legal services allowed by the court..   | 300.00      |                |             |
| To G. A. Miller, attorney for Jewelers' League, in full for their proportion of claims assigned to them, face value, \$8,454; dividend, 68 4-10 %. | 5,784.06    |                |             |
| To Randel, Baremore & Co., for claim proved...   | 205.25      |                |             |
| To H. & G. Soule, " " " ...  | 63.42       |                |             |
| To Chas. Gagnebin, " " " ...   | 3.42        |                |             |
| To Enos Richardson & Co., " " " ...  | 342.09      |                |             |
| Total Payments.....  | \$8,563.61  |                |             |
| Balance remaining.....   | \$3,082.98  |                |             |
| Mch. 12th, Additional order of Judge Donohue granted this day for payment of the following claims:   |             |                |             |
| Original Subscriber.   | Sub'n.      | Div'd.         | Amt.        |
| Wm. Ruhl .....   | \$250.00    | .68 4-10       | \$171.20    |
| D. M. Fitch, for 1/3 of Merrill, Fitch & Allin's \$200.....  | 66.66       | "              | 45.59       |
| Thos. G. Brown.....  | 150.00      | "              | 102.60      |
| A. M. Hays.....  | 100.00      | "              | 68.40       |
| Chas. Rubens & Co.....   | 500.00      | "              | 342.00      |
| Jacot & Gerard.....  | 100.00      | "              | 68.40       |
| Manchester, Harriott & Co.....   | 100.00      | "              | 68.40       |
| Wm. C. Arthur.....   | 100.00      | "              | 68.40       |
| Sackett, Davis & Co.....   | 150.00      | "              | 102.60      |
| Cross & Bequelin.....  | 100.00      | "              | 68.40       |
| A. Squadrilli.....   | 15.00       | "              | 10.26       |
| Middleton & Bro.....   | 100.00      | "              | 68.40       |
| Falkenau & Pollack.....  | 50.00       | "              | 34.20       |
| E. W. Manchester.....  | 25.00       | "              | 17.10       |
| I. Sturn.....  | 25.00       | "              | 17.10       |
| Wm. J. Miller.....   | 100.00      | "              | 68.40       |
| R. Longman's Sons .....  | 100.00      | "              | 68.40       |
| Arthur Rumrill & Co.....   | 200.00      | "              | 136.80      |
| Louis Durr & Bro.....  | 25.00       | "              | 17.10       |
| Demmert Bros.....  | 25.00       | "              | 17.10       |
| A. Coles & Co.....   | 25.00       | "              | 17.10       |
| J. B. Laurencot.....   | 20.00       | "              | 13.68       |
|  |             |                | \$1,591.63  |
| Balance still on hand.....   |             |                | \$1,491.35  |

It will be noted that Mr. Woglom in his annual report to the League, accounts reported as having received \$4,441.93. The difference between this sum and that turned over by the trustees, \$1,342.13, was expended by Mr. Woglom in obtaining assignments from the original contributors to the fund of their several interests therein in printing and stationery, and in defraying sundry other expenses, legal and otherwise, necessary to the presentation of the matter to the court, and for which vouchers were obtained and audited as will be seen by the annexed certificate:

(Copy.)

At the request of Gilbert T. Woglom, trustee, we have examined his account as trustee with accompanying vouchers and find the same correct, namely, amount received by decree from the court, fifty-seven hundred and eighty-four and  $\frac{6}{100}$  dollars (\$5,784.06), less expenses as per vouchers, thirteen hundred and forty-three and  $\frac{3}{100}$  dollars (\$1,344.03), leaving balance in his hands, forty-four hundred and forty-one and  $\frac{3}{100}$  dollars (\$4,441.03), for which he holds certificate of deposit of Chatham Bank.

(Signed) CHARLES G. LEWIS,  
C. G. ALFORD.

Jan'y 5th, 1884.

The amount awarded by the court to Messrs. Richardson and Randel, trustees, for their services in caring for the fund, \$292.25, was donated by them to the League. This is a concise and accurate recital of the history of the Chicago Relief Fund, and it reflects great credit upon the trustees for their judicious management of the money entrusted to their keeping, as well as upon Mr. Woglom for his persistent efforts to secure for the League the portion awarded it by the court.

[Copyright Secured.]

Letters to Watchmakers.

[By DR. LEONARD WALDO, Astronomer in charge of the Horological Bureau of the Yale College Observatory.]

III.

FOREIGN WATCH TRIALS.

FOR THE sake of comparison let us examine a certificate of rate of the highest class issued by the Geneva observatory for a watch entered at that observatory June 29th, and returned August 11th, 1882. The entire arrangement of the certificate differs from those of the Yale and Neuchatel observatories. The trial is arranged in eight periods of five days each, beginning and ending at ordinary temperatures and the position "Pendant Up." The five positions of adjustment are the same as in the Yale certificate, the only one omitted being that of "Pendant Down" in both certificates. In the Yale and Neuchatel certificates the advantage of a longer run in the two important positions of Dial up and Pendant up is secured. The disadvantage in the Yale and Neuchatel certificates is that the two day trials with "Pendant Right," "Pendant Left" and "Dial Down" are not long enough to determine accurately the rates in these positions. It is very well known that some time is required for a watch to take up its new rate in a change of position. This may be owing to a variety of causes, such as the thickening of the oil about particular parts of the pivots and the time required for its redistribution in its new position, or the balance spring may require a certain time to take up its isochronous vibrations, or the balance rim itself may be differently influenced by its centrifugal motion in the different positions.

Whatever the cause is, the fact remains that the first day rating in a new position is apt to vary from the rating on subsequent days, and thus an inaccurate idea of the daily variations in the different positions is given unless the trial in these positions is longer than two days. On the other hand, if the trial is made long enough to be satisfactory as a scientific test, it is too long for the makers, who gen-

erally cannot afford to have their capital locked up in watches at observatories. At least two months (and three would be better) is needed to give a trustworthy record of a watch's performance; but as this is too long a time for the producers in their present stage, perhaps the best available arrangement is that given by the certificate below, with the modification proposed of inserting an extra day before the beginning of a rating in any new position. This day is to allow the watch to make up its new rate. In the record following the 1st column gives the dates between which the rates in column 3 are computed. Column 2 gives the temperature in Centigrade degrees at which the watch was kept. The fourth column is found by subtracting the mean of the five daily rates in each period from the corresponding daily rate of column 3. The fifth column gives the positions during the periods.

In the tables of "Results," column 7 gives the mean of the 5 temperatures in each period in column 2, and column 9 gives the mean of the rates in the same period. Column 10 gives the sum of the variations found in column 4 without regard to their signs. The "sum of the variations for the 8 periods" is found by adding these separate period variations together. The "mean variation of the daily rate is found by dividing the sum of all the variations in column 4 by 40, the total number of days." The "mean rate during the periods 1, 2, 3, 5, 7, 8," is found by taking the mean or average of the rates of these periods from column 9, and the succeeding lines which give the variation of the rates during these periods are found by simple subtraction. The sum of these variations is taken without regard to sign. The six periods referred to correspond to six changes of position, and we derive a "mean variation corresponding to a change of position" by dividing the sum by six.

RECORD.

| 1<br>Date, 1882. | 2<br>Temperature,<br>Centigrade<br>Degrees. | 3<br>Daily Rate. | 4<br>Variations from<br>the Mean Rate<br>for the Period. | 5<br>Period of Rating, Position<br>and Temperature.  |
|------------------|---|------------------|--|--|
| July             | °   | S                | S  |  |
| 1 to 2           | 20.7  | -1.7             | +0.4   | 1st Period in the position,<br>"Pendant up" and at<br>ordinary temperatures.               |
| 2 " 3            | 20.2  | -2.0             | +0.1   |  |
| 3 " 4            | 19.9  | -1.2             | +0.9   |  |
| 4 " 5            | 19.9  | -2.8             | -0.7   |  |
| 5 " 6            | 19.6  | -2.8             | -0.7   |  |
| 6 " 7            | 19.2  | -1.1             | 0.0  | 2d Period in the Position,<br>"Pendant to the right"<br>and at ordinary tem-<br>peratures. |
| 7 " 8            | 19.2  | -0.9             | +0.2   |  |
| 8 " 9            | 18.9  | -1.2             | -0.1   |  |
| 9 " 10           | 18.2  | -0.6             | +0.5   |  |
| 10 " 11          | 18.1  | -1.7             | -0.5   |  |
| 11 " 12          | 18.3  | -3.2             | +0.1   | 3d Period in the Position,<br>"Pendant to the left"<br>and at ordinary tem-<br>peratures.  |
| 12 " 13          | 18.2  | -3.4             | -0.1   |  |
| 13 " 14          | 18.1  | -3.8             | -0.5   |  |
| 14 " 15          | 18.9  | -3.5             | -0.2   |  |
| 15 " 16          | 19.3  | -2.5             | +0.7   |  |
| 16 " 17          | 4.6   | +1.0             | +0.3   | 4th Period in the Position,<br>"Dial up" and at the<br>temperature of the ice<br>box.      |
| 17 " 18          | 4.0   | +0.5             | -0.1   |  |
| 18 " 19          | 3.9   | +0.1             | -0.5   |  |
| 19 " 20          | 4.3   | +0.9             | +0.2   |  |
| 20 " 21          | 5.2   | +0.7             | +0.1   |  |
| 21 " 22          | 21.5  | +2.1             | +0.9   | 5th Period in the Position,<br>"Dial up" and at ordi-<br>nary temperatures.                |
| 22 " 23          | 21.7  | +1.5             | +0.3   |  |
| 23 " 24          | 21.7  | +1.1             | 0.0  |  |
| 24 " 25          | 21.4  | +0.4             | -0.8   |  |
| 25 " 26          | 20.4  | +0.8             | -0.4   |  |
| 26 " 27          | 32.3  | -0.6             | +0.1   | 6th Period in the Position,<br>"Dial up" and at the<br>temperature of the oven             |
| 27 " 28          | 32.6  | -1.3             | -0.5   |  |
| 28 " 29          | 34.0  | -0.4             | +0.3   |  |
| 29 " 30          | 33.6  | -0.8             | 0.0  |  |
| 30 " 31          | 33.4  | -0.6             | +0.1   |  |
| 31 to Aug. 1     | 19.3  | +1.3             | -0.3   | 7th Period in the Position,<br>"Dial down" and at<br>the temperature of the<br>room.       |
| 1 " 2            | 19.8  | +2.0             | +0.4   |  |
| 2 " 3            | 20.0  | +1.4             | -0.2   |  |
| 3 " 4            | 20.2  | +1.8             | +0.2   |  |
| 4 " 5            | 20.2  | +1.4             | -0.1   |  |
| 5 " 6            | 19.9  | -2.5             | 0.0  | 8th Period in the Position,<br>"Pendant up" and at<br>the temperature of the<br>room.      |
| 6 " 7            | 19.9  | -1.2             | +1.4   |  |
| 7 " 8            | 20.0  | -2.5             | 0.0  |  |
| 8 " 9            | 20.1  | -3.8             | -1.2   |  |
| 9 " 10           | 20.2  | -2.8             | -0.2   |  |

## RESULTS.

| 6<br>PERIOD.                             | 7<br>Mean<br>Temperature. | 8<br>Position. | 9<br>Mean Rate. | 10<br>Sum of the<br>Variations. |
|--|---------------------------|----------------|-----------------|---------------------------------|
|  | 0                         |                | S               | S                               |
| 1  | 20.1                      | Pendant up,    | -2.10           | 2.8                             |
| 2  | 18.7                      | " right,       | -1.10           | 1.4                             |
| 3  | 18.7                      | " left,        | -3.28           | 1.6                             |
| 4  | 4.4                       | Dial up,       | +0.64           | 1.2                             |
| 5  | 21.3                      | "              | +1.18           | 2.4                             |
| 6  | 33.2                      | "              | -0.74           | 1.0                             |
| 7  | 19.9                      | Dial down,     | +1.53           | 1.2                             |
| 8  | 20.0                      | Pendant up,    | -2.56           | 2.8                             |
| Sum of the Variations for the 8 Periods, |                           |                | - - -           | 14.4                            |

|   |         |   |            |
|---|---------|---|------------|
| MEAN VARIATION OF THE DAILY RATE, - - = $\pm 0.36s$ . |         |   |            |
| Mean Rate during the Periods 1, 2, 3, 5, 7, 8,        | - - - - | = | -1.05s. S. |
| Variation of the Rate during 1st Period,              | - - - - | = | -1.05      |
| " " " 2d "  | - - - - | = | -0.05      |
| " " " 3d "  | - - - - | = | -2.23      |
| " " " 5th "   | - - - - | = | +2.23      |
| " " " 7th "   | - - - - | = | +2.63      |
| " " " 8th "   | - - - - | = | -1.51      |
| Sum of the Variations, - - - -                        | - - - - | = | $\pm 9.70$ |

|  |                         |                    |               |
|--|-------------------------|--------------------|---------------|
| MEAN VARIATION CORRESPONDING<br>TO A CHANGE OF POSITION, = $\pm 1.62s$ . |                         |                    |               |
| Mean Temperature during the Periods 4, 5, 6,                             | - - -                   | =                  | 19.7°         |
| Mean Rate " " " " " " " "  | - - - -                 | =                  | +0.36s.       |
| Period 4, Variation of the Temp. = -15.3°                                | Variation of the Rate = | +0.25s.            |               |
| " 5, " " " " " " " "   | = +1.6                  | " " " =            | +0.82         |
| " 6, " " " " " " " "   | = +13.5                 | " " " =            | -1.10         |
| Sum of the Variations " " " " " " " "                                    | = $\pm 30.4^\circ$      | Sum of the " " " = | $\pm 2.20s$ . |
| ERROR OF COMPENSATION IS 0.07s. FOR $\pm 1^\circ$ .                      |                         |                    |               |

The mean temperature during the periods 4, 5 and 6 is found by dividing the sum of all the temperatures by 15. During the fourth period the watch is dial up in the ice box; during the fifth period the watch is dial up at ordinary temperatures; during the sixth period the watch is dial up in the oven. These three periods are used to determine the error of compensation. In order to do this the mean temperature for the periods 4, 5 and 6 is first found, and then from this mean the mean temperatures for these periods are respectively subtracted. Thus the mean temperatures being 19.7, the variation of temperature for the ice box would be  $19.7 - 4.4 = 15.3^\circ$  and in a similar manner for periods 5 and 6. The "sum of the variations is" formed by adding the three variations together. In a similar manner the sum of the variations of the rates during the three periods is derived. If we divide the sum of the variations of the rate by the sum of the variations of the temperature during the three periods, we obtain the error of compensation for one Centigrade degree. Since each Centigrade degree is equal to one and eight-tenths Fahrenheit degrees, to compare this compensation error with the Yale certificated compensation error, it would be necessary to divide it by one and eight-tenths.

In the Geneva certificate we have arrived at the same general quantities, by an altogether different process, that we obtained in the Yale certificate. Thus we have:

1. The mean variation of the daily rate.
2. The mean variation of the daily rate corresponding to a change of position.
3. The variation of the daily rate for  $1^\circ$  C. or for  $1^\circ$  F.

In the Yale certificate should the mean variation of the daily rate in the position "Pendant up" exceed  $2^s.0$  on any day the watch loses its certificate. In the Geneva certificate the same penalty is attached if the watch rate on any day exceeds by  $1^s.5$  its mean rate for the same period and position. This latter arrangement is more favorable to the watch than the former. Suppose, for instance, that we had for pendant up the following rates for a period of five days:

|         | S.   | S.                       |
|---------|------|--------------------------|
| 1st day | +4.8 | variation from mean +1.4 |
| 2d "    | +2.4 | " " " -1.0               |
| 3d "    | +3.5 | " " " +0.1               |
| 4th "   | +2.0 | " " " -1.4               |
| 5th "   | +4.5 | " " " +1.1               |
| Mean    | +3.4 |                          |

The variation from the mean for no day exceeds  $1^s.5$ , and, therefore, the watch would pass muster for the Geneva certificate. The difference of rates between the first day and the second is  $2^s.4$ , and between the fourth and fifth days is  $2^s.5$ , and so in two cases it would fail of a Yale certificate. The Geneva certificate calls for the same performance in all positions, and at all temperatures. It is in this respect more severe than the Yale certificate.

For the second requirement, the position variation, it is necessary that the difference in rates between pendant up (or hanging), and dial up (or lying), should not exceed nine seconds. In the Yale certificate this difference must not exceed ten seconds, nor must the rate exceed ten seconds in the other three positions, pendant right, pendant left and dial down.

For the third requirement the compensation error must not exceed  $0^s.5$  for  $1^\circ$  C., which must be  $0^s.28$  for  $1^\circ$  Fahr., which is practically the same as the Yale requirement of  $0^s.30$  for  $1^\circ$  Fahr.

It will be observed, therefore, that the present observatory trials as conducted at Neuchatel and at Yale, are probably more severe in their requirements than those at Geneva. A single mistake in the rating of the watch at Neuchatel or Yale would reject it in spite of a most excellent average performance. This has happened at Yale (and I doubt not at Neuchatel) in some excellent movements. The chief objections urged against the Geneva trials is that the five days at the low temperature congeals the oil, and that when the watches are removed from the ice box for winding and comparing that the moisture of the warmer air into which they are moved condenses upon their polished surfaces. Another objection urged is that by exposing them for 5 days into the hot box the expansion of the balance is such that the rim takes a permanent "set" and the compensation is affected thereby. None of these objections exist as a matter of fact. "Ice-box" sounds very cold, but the temperature of this box ranges from  $3$  to  $8^\circ$  C., or from about  $38$  to  $47^\circ$  F. The hot box ranges in temperature from  $25$  to  $30^\circ$  C. or from  $77$  to  $86^\circ$  F.

When the watches are taken out of the cold box into the temperature of an ordinary room the change is not so great as when a watch is worn on a frosty day from the outside to the inside of a house, and the temperature to which it is exposed in the hot box is not so high as that to which it is exposed on a warm summer's day. Furthermore, during the operation of comparing and winding while the watch is in the cold box, there does not sufficient time elapse to cause the moisture to condense because the condensation of moisture on the movement of a watch implies that a considerable amount of air is able to circulate about it. Experience, therefore, has shown that there is not the slightest danger to be apprehended from these sources, and the greater fairness of judging a watch by its average performance in all positions for nearly equal periods of time leads us to the conclusion that we shall adopt essentially the Geneva scheme after June of the present year.

We shall probably lengthen the trial to 45 days in order to have the periods which in the Geneva scheme are marked 4, 5, 6 and 7 of six days each so that the first day in each period may be rejected.

The Geneva certificates are divided into two classes, the ordinary certificate and the certificate in which the watch is certified to have fulfilled the conditions of the trial in "a very satisfactory manner." To obtain this latter certificate it is necessary that the mean variation of the daily rate for any period shall not exceed  $0^s.75$ , and that the mean variation corresponding to a change of positions shall not exceed  $2^s.5$ , and the error of compensation shall not exceed  $0^s.2$  for  $1^\circ$  C. The certificate quoted above belongs to this class.

## The Jewelers' Security Alliance.

President, DAVID C. DODD, JR.

Vice-President, AUGUSTUS K. SLOAN.....Of Carter, Sloan &amp; Co.

Treasurer, W. C. KIMBALL.....Of H. F. Barrows &amp; Co.

## EXECUTIVE COMMITTEE.

C. G. ALFORD, *Chairman*.....Of C. G. Alford & Co.

C. B. BISHOP.....Of Carrow, Bishop &amp; Co.

HENRY HAYES.....Of Wheeler, Parsons &amp; Hayes.

J. B. BOWDEN.....Of J. B. Bowden &amp; Co.

DAVID UNTERMAYER.....Of Keller &amp; Untermeyer.

E. F. DORRANCE.....Of Dorrance &amp; Brother.

P. O. Box 3277.

HENRY W. HILLER, *Secretary*, Room 2, 170 Broadway, New York.

The March meeting of the Executive Committee of the Jewelers' Security Alliance was held on the 13th

Present, Messrs. Dodd, Sloan, Alford, Kimball, Hayes, Bowden and Dorrance. The resignation of Mr. C. B. Bishop, as Chairman of the Executive Committee, on account of ill-health, was accepted with regrets of the Committee. Mr. Alford was elected as Chairman. The Committee on renting an office reported that they had secured Room No. 2, 170 Broadway. The Treasurer was directed to deposit two thousand dollars in the Union Trust Co.

The following gentlemen and firms were admitted as members: Charles Bachman, George T. Smith & Co., Charles A. Warner, Sam'l T. Little & Son, J. B. Trickey & Co., W. Y. Young, A. D. Putis, E. C. Dawson & Co., Maurice Klater, T. G. Dillon, W. M. Fisher & Co., W. L. Hoskins, Sam'l C. Tappin, Peter B. Simons & Co., Arnold & Webster, Julius Hairhouse, Carter Bros., James Mix, Marsh & Hoffman, L. Miller & Bro., W. T. Antiman, P. D. F. Gourney, W. H. Williams & Son, C. E. Babcock, E. Shipley, Chas. E. Butler, L. F. Eley, F. N. Tompkins, E. W. Bixler, W. Shweigert, Webb C. Ball, James W. Cusack.

## Auxiliary Compensation.

BY T. W. BURGER.

THE MANY able articles which have been published in the various horological journals, as well as in other forms, on the "Expansion Balance," render it perhaps unnecessary in giving a description of Heinrich's Auxiliary to go over the same ground in detail.

While omitting all explanations of the methods employed in constructing and the manner of compensating balances in general, it would not accord with the object of this article to neglect a reference to the main cause of their imperfect performance in different temperatures.

If the expansion and contraction of metals was affected by changes of temperature, in exactly the same ratio as their elastic force, the question of perfect compensation would have been solved long since.

As it is, the one element—temperature—acts upon these two specific properties or forces of metals unequally, and as the variable condition of these unequal forces governs, to a great extent, the vibrations of the balance in different temperatures, the vibrations must vary or be unequal also. The question has been "how to properly utilize these unequal forces so as to produce equality of action or its equivalent."

For years past the attention of chronometer makers has been turned in this direction, and the result has been the invention of various devices of more or less merit; but none of them, it is claimed, have so satisfactorily demonstrated the problem as the one known as Heinrich's Auxiliary. This consists of a steel cross bar, about  $\frac{1}{8}$  less in length than the inner diameter of the balance, having on each end a circular arm, whose ends are diametrically opposite. The cross bar is made to fit friction tight on the staff; the arms being concentric with the balance and, with their free ends close to the bar of the balance. A weight, or compensating screw is placed at the inner

extremity of each arm, and as the arms are composed of brass and steel, disposed in the same manner as in the balance, they are affected similarly by changes of temperature.

In the balance rim, opposite each of these arms, are three screws of uniform size and length; the central ones touching the arms midway their length—the others ten degrees distant on either side.

The cross bar is placed  $60^\circ$  from the balance bar. These positions are not arbitrary; but have been found to be the best as a starting point from which to make trials.

In operation, this auxiliary, like some others, acts on the principle of a lever; but differs from them in having two points of application, which bear such a relation to each other, that in heat one acts in an increasing ratio, while in cold the other acts in a decreasing ratio. In order to make this appear more clearly, the screws which control the action of the auxiliary are designated in the cuts as Heat, Middle and Cold. Experiments with balances of usual construction have shown the natural error, in a range of  $60^\circ$  of temperature, to be about 3 seconds. This error, by means of the ordinary compensation screws, is generally divided so as to disappear in the middle temperature and show equally at both extremes.

The object of Heinrich's Auxiliary is not to disturb or interfere with this usual compensation; but to eliminate the natural error, which ordinary compensation fails to do.

FIG. 1

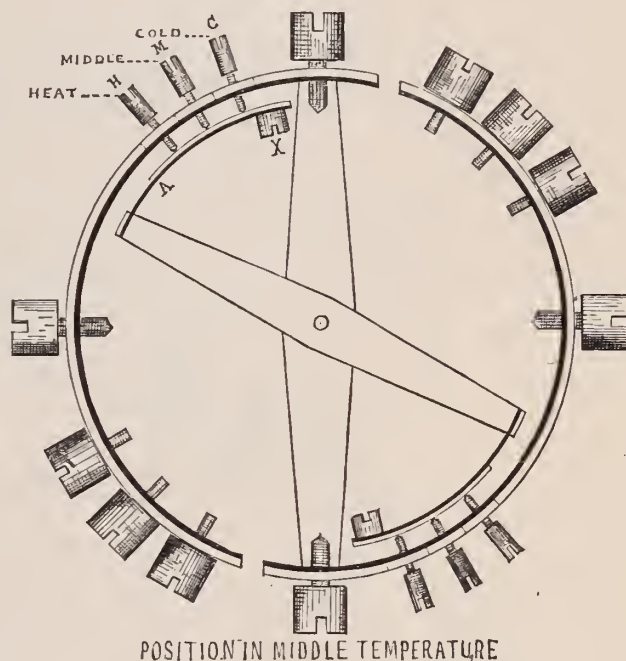

In the use of this auxiliary it is absolutely necessary that in the middle temperature the three screws *H*, *M* and *C* should touch the arm *A* equally (see fig. 1) and that this condition should never be altered, except while making corrections by moving the screws *H* or *C* nearer to the screw *M* or farther from it as occasion may require; and if moved, the condition imposed above must be verified. The necessity of this will at once be seen, when it is borne in mind that the middle temperature is the base or turning point of its action and that the screws *H* and *C* must be in position to act at once when this turning point is passed in either direction, by a rise or fall of temperature. In the middle temperature the usual compensation of the balance would be unimpaired by an entire removal of the auxiliary; for at this point there is neither contraction or expansion of the balance and consequently the auxiliary has no action.

A general rule is applicable in making corrections by means of the screws *H* and *C* (which are employed only when the error is large) viz.: "when slow in both extremes they are too near the central screw *M*, and when fast in both extremes too far from it."

Having in mind the fact that screw *H* operates only in heat, it will be seen that the moment the temperature rises, the inward movement of the balance rim will cause the screw to press against and force

the arm of the auxiliary toward the center of motion, and away from the points of the other screws, as shown in fig. 2.

FIG. 2

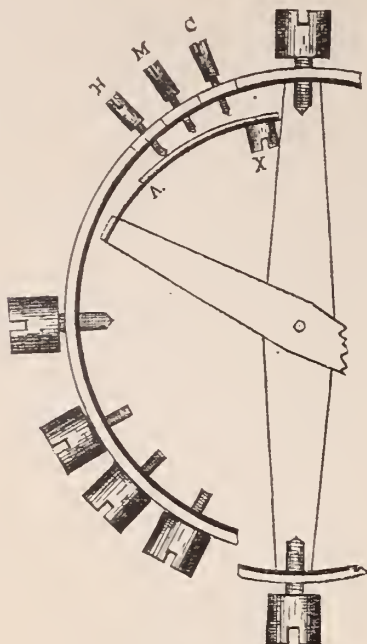

POSITION EXAGGERATED

By moving screw *H* still farther from *M*, not only is the extent of its movement increased, but also its leverage, because its point of contact is carried so much farther from the free end of the auxiliary arm, thus giving it power in an increasing ratio over the inward movement of the arm and its compensating screw *X*.

The outward movement of the balance rim, as the temperature falls, draws the screws *H* and *M* away from the auxiliary arm, leaving *C* alone to restrain its outward tendency, as shown in fig. 3. If it

FIG. 3

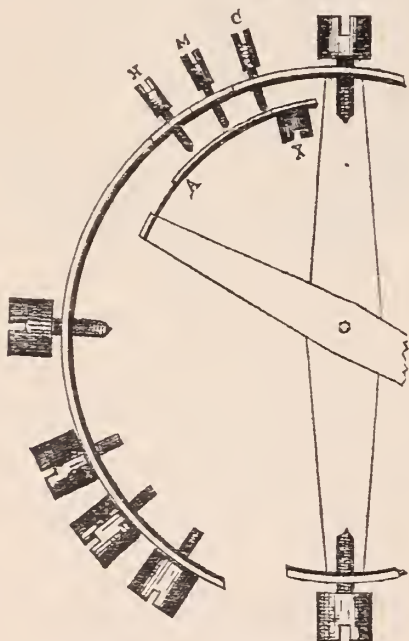

POSITION EXAGGERATED

be necessary to change screw *C* to a more favorable position, its restraining effect will be increased by placing it farther from *M*, because its own outward movement is thereby decreased; and a change in the opposite direction would be attended with a contrary effect.

Small errors may be corrected by moving the bar of the auxiliary in either direction on the staff. If moved to the right the result would not be a gain in heat only, but a loss in cold also; the gain, as compared with the loss, being in the ratio of six to one; and the reverse effect for a movement to the left. The reason for this ratio is on account of their relative positions; the screw which operates in

heat being always on the side of increasing ratio, while the screw which operates in cold is on the side of decreasing ratio.

The practical adjuster, after a little experience, will find that this auxiliary affords the means of readily accomplishing that which has heretofore been considered practically impossible.

In moving the auxiliary bar for the purpose of correcting small errors, it is not necessary to remove the balance from the movement, thus reducing the labor and greatly shortening the time usually required in making temperature adjustments.

Its action is both *continuous* and *progressive*, and in use has given most remarkable results in both extremes.

A trial was made at the Washington observatory with a chronometer having this auxiliary, showing a variation of but one second in twenty-four hours in a range of 102 degrees Fahr., whereas, without the auxiliary, the natural error would have been about seventeen seconds.

This trial extended over a period of six months in various temperatures; the difference between the first period of ten days and the last being only five-tenths of a second.

The result of its performance during the entire time was of such a high order as to be noticed by a contributor to the *Revue Chronométrique* of June, 1881, who wrote in regard to the auxiliary that "if constructed and adjusted according to the principle of its theory it would approach perfection."

## Views of Correspondents.

This department of **THE CIRCULAR** is open for communications relating to the jewelry trade, but the editor does not hold himself responsible for the sentiments expressed by contributors. We invite correspondence, but require that it shall be free from all personalities, and the writer's integrity guaranteed by the disclosure of his true name to the editor. Anonymous communications will not be noticed.

### WATCH ESCAPEMENTS.

To the Editor of the *Jewelers' Circular*:

I have noticed with considerable interest the discussion that has been going on in the horological journals for some time past in regard to the merits of large and small angle lever pallets and long and short forks, etc. I have thought that perhaps some of my experiments in that line, for the last ten years might be of interest to some of your readers.

It may be proper to state, for a better understanding of what follows, that we use two sizes of trains in the manufacture of our "Time Locks." The large size is about the same as the ordinary French clock train. Mainspring,  $\frac{3}{4}$  inch; escape wheel,  $\frac{3}{4}$  inch in diameter.

The small trains are about the same as the three inch box chronometer. Mainspring,  $\frac{1}{2}$  an inch; escape wheel,  $\frac{1}{2}$  an inch in diameter.

The escape wheels, in both, ratchet teeth; both trains, 14,400; and both proportioned and finished with all the care and exactness of the best chronometers.

The large train has 10-leaved pinions; the small train, second wheel pinion, 10; the rest 8.

We started with a 10° pallet and double roller, made up in accordance with Mr. Grossmann's rules, except a little more draw on the lockings, and the same draw on both arms of the pallet. This did not prove quite as satisfactory as I wished. There was a sluggishness of the balance that neither a long nor a short fork quite overcame. I then tried a 12° pallet with the usual proportion of fork. This was a decided improvement. We then began the manufacture of the small movements, and first tried in them a 15° pallet with the proportion of fork and roller as in the larger size, all with about 2 or 2½ degrees locking of the escape wheel. Now for the results: With the 10° pallet, a full turn of the balance was about all that could be got out of it. With the 12° pallet, a turn and a quarter to a turn and a half was the average. With the 15° pallet (with the

same balance and hair spring), it would overbank nearly all the time. This, of course, would not answer, so we went back to the 12° pallet.

Now came the imperative demand that the clocks must start the instant winding began. (They ran down to unlock, and then stopped till they were rewound to set them). To overcome this difficulty required some study, so as to make as slight a change as possible, and maintain the quality of the work and *certainty of performance under all circumstances*.

The 12° pallet was retained and the fork and roller action changed, and so proportioned that the balance arc was 45° at the impulse circle, and the diameter of the impulse pin 6°, or one-half the pallet angle. The impulse pin is so located that when ground to the impulse circle one-third of its circumference is removed, and it is then polished and slightly cornered. The pallets are banked to 2 or 2½ degrees locking of the wheel, and the fork-notch and crescent very accurately fitted to the impulse pin and circle and the safety pin to its roller, so that while there is perfect freedom there is no side-shake. Now, on opening the bankings (eccentric screws) a trifle, the balance took a fine motion; but on stopping it, it would not with positive certainty always start on beginning to wind. To obviate this difficulty, I, very much against my judgment, but as the best alternative, reduced the diameter of the escape wheel (the balance, of course, removed during this adjustment), till the wheel would barely hold on the locking with a slight pressure on the train, and banked as close as it could be and escape.

At first sight this would seem to be fatal to all durability and good performance of the escapement, but it did not prove to be so. On replacing the balance and opening the bankings to allow proper freedom to the fork and roller action, the motion was largely increased and frequently overbanked. This required a thinner mainspring, and, of course, there was less danger of its breaking and less friction and wear.

Some may ask "How will this work in a movement where accurate time is required?" I will say that it gives the best results possible to obtain from the lever escapement.

During the connection of the impulse pin with the fork, the balance has the greatest velocity it ever attains, and the pallet is carried to its banking as soon as the wheel strikes the locking.

This I did not expect before trial, and thought, with almost all experienced workmen and escapement makers, that a few months at most would use up the escapement. But after over six years' trial they are still as perfect as when new, and it is almost impossible to stop a movement made up in this way and proportion.

I think these proportions *essential* to the best performance, and they are the results of very careful experiments.

With this length of fork the full diameter of the impulse pin comes within the notch before the wheel is unlocked, and it is thus in position to receive the impulse of the wheel, and the unlocking and impulse are as near the line of centers as is possible.

There is no cutting of the jewels or wheel teeth in these escapements, as there might be with a faulty fork and roller action or with imperfect jewels.

All lever escapements should be oiled; the fork enough to prevent rust in the notch; also the pallets, or destruction is certain sooner or later, even with sapphire jewels. Durability, with a long steady rate, is the end sought in fine watches.

As to weight of balance:

We so proportion it to the power used that when the escape wheel teeth are on the impulse planes, as they are when the balance is at rest, the power is sufficient to start it; and the balance is heavy enough, also, to unlock the pallet. A heavier balance (up to a certain extent), will increase the arc of vibration, but is not desirable for our purpose.

Our trains are formed after the rules given in the journal of May, 1877, page 56, and are not excelled for exactness of proportions or smoothness of running by anything I have ever seen. I find on trial

that 8-leaved pinions transmit more power of the mainspring than those with 10 leaves, with wheels of the same diameter.

The balances that were just right for our large movements would overbank in the small ones. The weight had to be reduced nearly one-half to prevent this (the same angle of pallet and fork and roller action in both cases), although the mainspring is much narrower and thinner.

These large movements, when made up with such care and exactness, show up peculiarities that are not readily seen, I think, in small movements.

A word as to the location of trains:

A right-angled escapement does not require as much power as a straight line, as there is less friction and waste of power.

If the entire train and escapement are located on the same straight line, a very much stronger mainspring is required than when so located that the power is as near as possible between the pivot and the resistance.

To illustrate: a pound weight placed in each pan of an even balance only weighs a pound, but there is two hundred weight on the pivots, and, therefore, more friction.

Last December I patented a chronometer escapement that I have been at work on for several years, endeavoring to so simplify its construction and proportions that it could be readily manufactured, and would be adapted to the ordinary use of a pocket watch and be equal to any chronometer for accuracy of time. I think I have fully succeeded in this. I have had one movement running two years and another one year.

Both require only about two-thirds the power that a lever movement of the same size requires.

L. F. MUNGER.

#### ADOPTION OF SYSTEM IN REPAIRING WATCHES.

*To the Editor of the Jewelers' Circular:*

System in all branches of business and professions, whether it be that of the banker, merchant or mechanic, in fact, to anyone desiring to make a success at his particular vocation in this life. System is the prerequisite of attaining it. Without it he is lost, "Like bread cast upon the waters." With it he is surely paving the way to (if not always a wealthy position in life), a certainly handsome recompense in the years to come. It is the mechanic and average watchmaker at the bench, who toils from morning till night, and whose existence at best is not an enviable one, that this article is intended for, and may prove of some benefit to many. Not so much for the competent workman who, in his earlier years, has had the advantage of a thorough and practical training under the rigid and disciplined mode of teaching apprentices, adopted by "Die Alten Meister" in the Fatherland. It is to the many jewelers that are strewn all over the country, who, perhaps, having served an apprenticeship of 2, 3 or 4 years, and who have consequently acquired the "knack" of "taking down a watch," cleaning it, putting in a new staff, pinion or cylinder, etc., etc., are launched out upon the world either as journeymen, or as is the case with many, to establish themselves in some small country town, but who, having once got to work, find themselves in the course of 2 or 3 weeks "blessed" with an insufferable amount of "stoppers," "stickers." It is these same workmen that should at once throw off the brand as "incompetent" and the mantle of "superficial" which hangs like an everlasting reproach on our profession. They must, in order to be classed as "competent" (if they desire it), adopt system in their work. There is no more excuse for a watch left for good order, and subsequently replaced into the pocket of its owner, if you know the latter to be careful in handling same, to be returned to you in a short time "stopped" (the breaking of mainsprings, of course, excepted), than it is for a carpenter, who professes to be a workman, to undertake the job of putting in a new door into one's dwelling and then not have it fit so as to be able to shut it. What a peculiar smile flits over the countenance of the systematical workman on being handed a watch which "has been cleaned across the way and won't go;" on opening

the same discover at a glance that the center post touches glass or back of case, or on looking into the watch, if a Lepine or Ancre, discover those "beauty lines" on barrel caused by coming in contact with center wheel, or lack of proper bushings. On the other hand what evidence of conscientious workmanship to behold a 7-jewel horizontal escapement with protruding bushings here and there, hair spring evenly coiled, the screw holes nicely chamfered and evenly blued, and giving such splendid results as a timekeeper. System has done it.

Hence it is a fact, and the opinion of many, that a cylinder escapement in such condition, and this implies that it has been in the hands of one who works systematically, even without the full number of jewels, will give better satisfaction than the general run of cheap, trashy Ancres with which the market is flooded. Go about your work systematically, and make your alterations accordingly. Impress this golden maxim upon the minds of your apprentices. Remember without it it is impossible to master any of the higher branches of our profession, such as adjusting to heat, cold, position and isochronism. A student at school might just as well undertake to master the higher arithmetics when he is incapable of comprehending the rudiments, as to endeavor to grasp the ideas of such eminent authorities as Saunier, Grossmann and "Excelsior," and put their theoretical problems into practical use without having acquired the habit of doing repairs thoroughly and systematically. It is not my intention in this article to set forth the "ways and means" to repair watches, as so many valuable articles have appeared from time to time in THE CIRCULAR, emanating from authors of reputation appertaining to same, that the readers, even if they have not had the proper training, can, by perusing these dilligently, acquire a great deal; besides this article is intended for those that *are* capable of doing repairs in a workmanlike manner but lack this great boon, system. I would, however, call attention to a few essential methods of going about to place a watch in good running order, and that is the preliminary examination before taking down. It is a fact that more than half of the jewelers, and many of these profess to be thorough, will, in taking down a watch, never dream of examining the case, the hands, glass, whether post touches latter, whether hour wheel needs bushing or common pinion touches plate, etc.; they leave this till after the watch has been cleaned and put back on rack as fixed, surprised to find it stopped, hands caught, etc. In connection with bushing, no workman who intends to have his work last, not only for the time being but for years to come, should resort to the somewhat popular method of closing up pivot holes with punches. It is always reprehensible. If he has an American lathe or a nice set of taper arbors, he can in 10 minutes' time make a good and firm bushing out of hard brass; besides, for smaller pivots, bouchons already drilled for use can be obtained of any material house. The mainspring barrel and its immediate connections is the seat of more trouble in the average run of cheaper watches than any other part of the watch, and yet it is equally as much ignored as the minute and hour works, and the repairer frequently is puzzled to find that his watch has such a poor motion when cleaned, when on taking out the barrel discovers insufficient play of arbor in the bearings, or too much, a bent tooth, faulty depthing, etc., whereas had he previous to cleaning examined all these and other parts, jewels, pivots, pinions, escapement, balance, etc., it would have saved him an almost endless amount of trouble, besides the annoyance of being classed as a "tinker-botch." So many jewelers consider that cleaning a watch constitutes  $\frac{9}{10}$  of the work to be done when in reality it is only  $\frac{1}{10}$ . When a watch in the hands of the systematical workman is ready for cleaning  $\frac{9}{10}$  of the work is done. In conclusion I would say, another important feature and overlooked by many: Never place a watch in the hands of your customer as finished until you are certain that it is regulated or pretty nearly so. A watch, no matter how costly it may be, is in the opinion of many worthless unless it keeps good time, and it is the only evidence that the layman possesses that he has had good work done; in other words had

had value received; therefore, never replace balance and spring before you have brought the regulator pretty close and are confident that the final regulating when in the case will finish it. "Excelsior's," Grossmann's and Fritz's method of timing springs should be read by everyone and practised. System, skill and the conscientious workman hand in hand, will surely reap the reward due him in a pecuniary point of view, and in the estimation of the community in which he lives.

ALBERT WETTSTEIN.

*To the Editor of the Jewelers' Circular:*

I am from time to time, yes, almost daily, in receipt of net price lists of watches, jewelry, etc., in *unsealed* envelopes, which I think a perfect outrage to the legitimate jewelry business and demoralizing to the trade in general. Now, can't you, by a few strokes of your pen, suppress this to a great extent by advising legitimate dealers *not* to buy of houses who send their list out so openly? I, for myself, would not, nor never did buy a dollar's worth from a firm who was guilty of such an act. A short time ago I was surprised by receiving a list in this way from a prominent watch factory and wrote them regarding the same immediately, and told them *I would never* sell another watch of their make if this was their style of doing business, when they assured me that it would never happen again. It would, however, leave me little time to attend to my own business if I had to write to each firm of whom I receive an unsealed list, so if there is anything you can do to wipe out this unprincipled business I am sure it will be appreciated by all retail dealers all over the country.

LOUIS C. EISENSCHMIDT.

## Lathes and Lathe Work.

BY THE MODEL WATCHMAKER.

I DO NOT wish to be understood to advise all watchmakers to make their own tools, but I emphatically insist on their being able to do so, if by any cause they should be compelled to such a necessity. In the present instance the chuck described is intended for the benefit of apprentices and journeymen of moderate means who cannot afford to buy an American lathe with a few hundred dollars in attachments just at the present. The writer has an American lathe with step chucks and universal head or face plate, and he has a chuck such as he is describing, only the one here described is in several ways improved, and he finds it good enough to be used with any lathe. In making such a chuck the face plate will be the most difficult; consequently we will commence with this and describe the details. Hard red cast brass will be the best, but hard rolled or hammered (planished) brass will answer. There is one fact in connection with rolled or hammered brass which I presume is not generally known, and this is it will spring in working, especially in such jobs as the face plate of our chuck. As, for instance, we turn out a disc for our face plate and scrape and grind one side perfectly flat, we turn over to the other side and finish that in the same way. Now, on testing the side we first finished, it will be found no longer true. On the other hand, if we use hard cast brass the work will stay as we finish it. In the present we will assume to use cast brass, and have the face plate *A* when first cast  $\frac{7}{8}$  of an inch thick and  $1\frac{3}{8}$  of an inch in diameter. I may change the size a trifle of some of the parts from the sizes given in former articles, but when I do so it will be with an eye to improvement. The cuts are intended to be of the exact size of all the finished parts. We will commence by filing and scraping one side of our disc perfectly true and flat, after which we will grind it on our plate glass slab so often spoken of in these papers. A hole should now be drilled in the center about  $\frac{1}{8}$  of an inch in diameter. We had now better make the part which screws into the lathe, a minute description of which is given in our last issue, but the cut is reproduced in at fig. 3, where *B* represents a longitudinal section in the direction of the axis of the lathe. The part *B* should be exactly  $\frac{5}{8}$  of an inch in diameter, and also made



of hard cast brass. The face plate *A* and hollow cylinder *B* should be secured to each other with three screws about  $\frac{1}{16}$  of an inch in diameter, with conical countersunk heads, and in addition to the three screws there should be three steady pins. The part shown in fig. 3 should be turned up and fitted perfectly before the face plate *B* is screwed on. After *A* and *B* are screwed together, *a* should be screwed into the lathe spindle and the outer face and edge of *A* turned off flat, finally finishing by scraping and grinding. The face plate *A* should now have the center hole at *b* turned to exactly  $\frac{1}{4}$  of an inch, when it (the face plate) can be separated from *B* and the slots for the jaws *D* fitted. We commence by laying out three radial lines as shown at *d d d*, fig. 4, on the back of the face plate *A*. This can readily be done by turning a plug to fit the hole at *b*; this plug should be delicately centered (it is best to turn the plug on this center), and from this center sweep the circle *f* shown in dotted lines in fig. 4; divide this circle in three equal parts and draw the lines *d d d* from the center through the three points established in the circle *f*. We next lay off parallel lines  $\frac{1}{10}$  of an inch distant on each side of *d* as shown at *c c*. This process is repeated at each of the radial lines *d* as shown. The part of the face plate *A* between the lines *c c* should now be recessed  $\frac{1}{32}$  of an inch deep. This can readily be done, first by filing and scraping to near the required depth, and finally finishing the recess by a special tool shown at fig. 5; this is a flat piece of steel exactly  $\frac{1}{32}$  of an inch thick at the end *F*. It is not absolutely necessary for this pin to be exactly this thickness, but near this thickness, but it should exactly correspond to the thickness of the flange on *D*. The end of the tool shown in fig. 5 at *F* should

the recesses *c* extend from the extreme outer edge of *A* to the hole *b*, while the slots do not go to the outer edge of *A* by  $\frac{1}{8}$  of an inch. The jaws *D* are the most difficult and tedious of this chuck to make, but with the instructions given they can be made accurately and not take a very great amount of time. The reader will notice I have made some changes in the form of these jaws from those given in former article; these changes were chiefly made to facilitate the making than for any other cause as the principle remains the same. These jaws should be made of steel (such steel as has been annealed in a charcoal box working the best) and they should be filed and scraped into near the required size before hardening, as in the process of hardening they will spring a trifle out of true. The steps in the jaws *D* should have about  $\frac{1}{24}$  of an inch rise. At fig. 1 are shown four views of one of the jaws of the exact size they should be made. These views are numbered in their order, 1, 2, 3 and 4; number 1, a side view as if seen in the direction of the arrow *g*, in fig. 2; number 2 is a view of number 1 as if seen in the direction of the arrow *h*; number 3 a view as if seen in the direction of the arrow *k*; number 4 as if seen in the direction of the arrow *j*. About the most difficult part of these jaws to fit up accurately is the inner surfaces of the flange *l l*, number 3, fig. 1. The face of this flange should be a plane on the dotted lines, as this flange sticks on the surface of the recess *c*, fig. 4. Now let us see how to get this surface perfectly flat and true. We take two pieces of metal *m m*, fig. 6, and join them by two pieces *n n*. An end view as seen in the direction of the arrow *p* is given at *G*. The pieces *m m* would be best made of soft gray cast iron  $\frac{3}{4}$  of an inch wide,  $\frac{1}{2}$  an inch thick and 4 inches long. The pieces *n n* can be of heavy brass (fully  $\frac{1}{8}$  of an inch thick),  $\frac{1}{2}$  an inch wide and  $1\frac{5}{8}$  long; the pins are united with screws as shown. The pieces *m m* should be filed and ground perfectly true and flat on the upper surface, and the inner surfaces corresponding to the lines *o o* (shown at *G*), should also be true and flat and at right angles to the plane of the upper surface of *m m*. The lower surface of the pieces *n n* is likewise ground flat and true. The holes in *n* where the screws go through for joining *n* to *m* are elongated so that the two pieces *m m* can be closer or farther apart; these screws should have washers under their heads. In fitting up the jaws *D* they are placed, with the clamp or step piece, between *m m*, and the face corresponding to *l l*, fig. 1, rests on the upper surface of *m m*. This arrangement can be used as a test to try the jaws when the first fitting up is done, and finally used with emery or oil stone dust and oil to finally grind them into perfect shape. The back of *D* can be ground into exact shape, but this must be carried over to our next number.

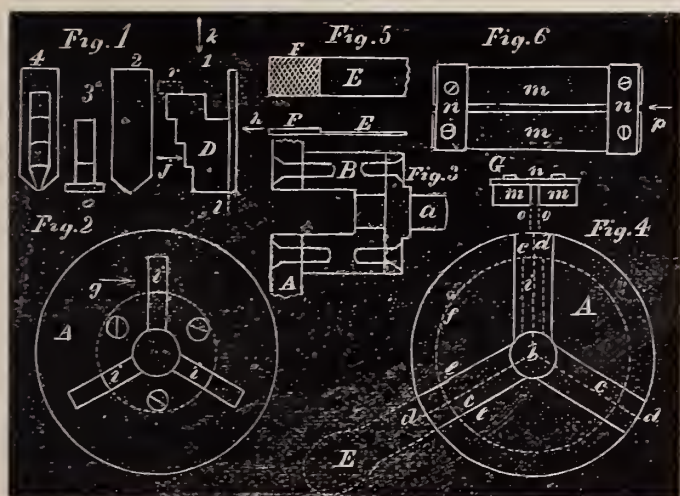

be uniform in thickness, *i. e.*, each corner and in the middle should measure the same with your micrometric callipers. The part at *E* should be made thinner or reduced to the thickness of an ordinary American mainspring. The part at *F* should now be cut with a graver until the face is as shown, the lines forming a file. It should now be hardened, protecting it with castile soap, and the part at *E* reduced to a spring temper so as not to break. The method of using this tool is to insert it into one of the recesses *c* as shown by dotted lines at *E*, fig. 4. I should have said the piece *F* was  $\frac{1}{10}$  of an inch wide so as to fit the recess *c*. As we ground the back of *A* perfectly true and flat, if we insert *F* as directed in the recess *c* with the cutting surface toward *A*, and apply another perfectly flat surface outside of *F*, and hold them between our thumb and finger exerting a moderate pressure, and move *F* back and forth by the handle *E*, it is evident that the roughened surface on *F* will soon rifle out the recess *c* to a uniform depth. This condition can readily be determined by *F* ceasing to cut which it will do as soon as surface of *A* and the extra plate come in contact. The reader will see that this little tool if used in the manner directed will rifle out the recesses *c* successively to exactly the same depth and width. Extending from and through the recesses *c* are slots shown at *i*, fig. 2 and 4, these slots are cut entirely through *A* and receive the jaws *D*. There is no especial instructions necessary for doing these; mere careful measuring and filing bring all that is needed. It will be seen that

## How to Make and Engrave Silver Bangles.

BY EXPERT.

THERE IS a slight modification of the form of pentagraph shown in our last issue which, for some uses, is an improvement. Among the advantages peculiar to this form (shown at fig. 1), is stiffness, and as we propose to make our machine cut actual lines this is a very desirable feature. The lines which we shall show how to produce are those of all others the monogram engraver must use, and at the same time those he hates to cut, as it is next to impossible to produce satisfactory results. We mean parallel lines across the face of letters. We will first give the details of construction and then show how our pentagraph will cut the lines referred to. The pieces *a b c d* should be made of some light stiff wood, yellow poplar, bass-wood or spruce, either will answer. They should be 1 inch square and 12 inches long, and in this case it will be assumed the pentagraph will only work to one scale, or as 4 to 1, when copying patterns, and when used as a ruling machine this will make no difference as it will rule across the face of any letter up to 3 inches high. The number of wooden pieces required will be six, four 12

inches long (1 inch square), two 3 inches long (1 inch square). The four longest pieces (*i. e.*, 12 inches), are joined at their meeting angles  $d^2 e g f$  by means of four brass butts or hinges as shown at  $d^2$ , fig. 2. If butts which extend back from the joint so as to take three screws (as shown at  $A$  which is a diagram seen in the direction of the arrow  $k$ ). To explain: the usual form of butts are not as wide as long; say we go to a hardware store and ask for one inch brass butts, we are shown butts measuring one inch in the direction of the joint, but the width of the wings in which the screw holes are would not be more than half an inch. But occasionally special butts can be obtained which will measure in the wing an inch or more with 3 holes. If such can be obtained they are undoubtedly the best. The butts do not want to be let into the wood but should be screwed directly to the pin as shown. After two pieces are joined as at  $d^2$ , fig. 2, the pin (which consists of a piece of wire), which forms the joint should be removed, and the holes carefully broached out with a broach which is only slightly taper, and a new joint pin inserted which was carefully turned up. This is to ensure close and good working joints. The joints where the short pieces  $i j$  join the long pieces  $a b$  are fitted in the same way, and the angles as at  $m$  (of both  $j$  and  $i$ ) should be cut away as shown to allow the instrument to be drawn forward. If the angle at  $m$  is 135 degrees (the complement of 45) it will answer. The joint at  $g^2$  will have to be made as it is to hold the cutting tool. There is no difficulty about the making only it would be well to hard solder the joint  $n$  as shown at  $B$ . This

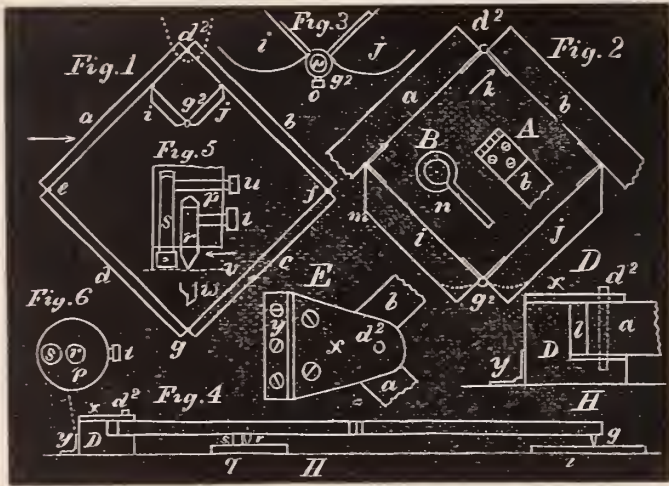

joint (at  $g^2$ ) should be large enough to admit a wire  $\frac{3}{16}$  in diameter as the lower end of this wire carries the cutter. This wire for the joint we will designate as  $p$ , and the lower end is shown magnified at fig. 5; this cut is a vertical section on a line extending from  $g$  to  $g^2$ , fig. 1. This piece  $p$  is the cutter and is made of a piece of steel wire about  $\frac{1}{8}$  of an inch in diameter, and is inserted into a hole drilled into the end of  $p$  to receive it. The hole for the cutter  $r$  need not be in the center of  $p$  but a little to one side. The piece  $s$  is a screw tapped into  $p$ ; this screw  $s$  should be as close to  $r$  as possible, and also as close to the outside of  $p$  as it can be drilled and tapped as shown in fig. 6 which is an end view of fig. 5. The head of the screw  $s$  should be smooth and have 2 holes drilled through at right angles to its axis to turn it. At  $t$  is shown a set screw for holding the cutter  $r$  in position. And at  $n$  is shown another set screw for preventing the screw  $s$  from turning when using the machine. The little figure at  $w$  is the cutter  $r$  seen in the direction of the arrow beside it. In order to understand how the cutter  $r$  works, we will suppose the dotted line at  $v$  represents the surface to be engraved, the cutter  $r$  is V-pointed and will penetrate into the work as far as the screw  $s$  will permit; so it will be seen that the depth and width of the line cut by  $r$  depends on the screw  $s$ . When the wire  $p$  is inserted in the joint at  $g^2$ , the set screw  $o$  holds it in position. It might seem at first sight that the set screw  $o$  working through the joint at  $g^2$  would cause  $p$  to slightly revolve as the tool  $r$  is moved back and forth, and so it does, but the slight turn practically amounts to nothing. At fig. 4 is shown an elevation of the machine seen in

the direction of the arrow in fig. 1. This fig. shows the action of the pentagraph when in use, and the dotted line extending upward from  $y$  shows the position of the machine (pentagraph) when not in use. The joint at  $d$  is attached to a block  $D$  shown at sub-drawings  $D$  and  $E$ , and also in dotted outline in fig. 1. The block  $D$  is shown separate at  $D$  in elevation; it should be  $1\frac{1}{2}$  inches high, with a top plate  $x$  of number 14 brass-shaped and attached as shown with two screws. The part of  $D$  on which the joint rests should also be of number 14 brass as shown at  $I$ ; this should also be attached to  $D$  with two screws. In the rear of  $D$  at  $y$  should be a 3 inch brass butt, one wing of the butt screwed to  $D$  and the other wing to the table or bed piece  $H$  on which the pentagraph works. The pentagraph will now be in the position shown in fig. 4, and will turn freely on the pin at  $d^2$  in the joint at  $D$ . We will suppose our dime or watch case is placed under the cutter  $r$  in the position indicated at  $g$ , fig. 4. In the joint at  $g$  is a tracing point, also indicated by the same letter, which follows a line cut in the pattern plate shown at  $z$ . In working the point  $g$  no care is required only to get the point once into the groove and it will not leave it. An eye-glass can be used to guide the cutter  $r$ . The next thing to be done is to get a guide plate for the point  $g$  to run in. This can be accomplished in several ways. The simplest is to have a zinc plate (even the light zinc such as is used to put under stoves answers very well), ruled into parallel lines. The ruling can be made in etching wax and the lines bit in deeply with dilute aquafortis. If your pentagraph is made as directed, *i. e.*, on the scale of 4 to 1, you will need about 4 guide or pattern plates. These plates should be ruled into lines, 12, 16, 20 and 24 to the inch, and should be 8 or 10 inches square. If this zinc is used any plate engraver almost can rule the lines in etching wax for you, and you can bite it in with aquafortis diluted, 5 water to 1 of acid. The lines need only be deep enough to ensure the steady and sure running of the point at  $g$ , fig. 4. Another way to obtain guide lines is to have them ruled directly in wood blocks same as wood engravers use. If the latter course is pursued, two blocks will answer for the 4 different spaces of lines. Probably all my readers know that the end of the grain of wood is used to engrave on, and if you have two blocks of such wood with two faces finished and ruled you will obtain the 4 widths of lines spoken of. Another method is to place a graduated screw under  $z$ , when you can obtain lines of any width either straight or curved; we will speak of the manner of doing this in our next.

### Trade Secrets.

WHILE IN conversation a short time ago with an acquaintance, a goldsmith, who, we are happy to say, does not represent the majority of his craftsmen, he frequently made use of the expression "trade secrets."

It is a singular fact that even in this, the nineteenth century, with our electric railways, telegraphs, telephones and other time-annihilating devices, we still meet with a class of workmen who cherish "trade secrets." They constitute the bulk of the class who are absolutely opposed to every innovation, no matter whether its several advantages are ocularly demonstrated to them or not; people who regard with a jaundiced eye everything that savors of improvement, and who are ready to swear to anything hoary and antiquated as if upon the Holy Writ. The representatives of this class can chiefly be found among the tradesmen of small towns, and especially among those of the "old school." To them everything is sacred that bears upon it the venerable imprint of age and savors of guild; they will pass through fire and water for the sake of their ossified opinions, and will rather jeopardize the loss of their customers and risk their very existence than to adapt themselves to altered circumstances.

Within these circles do we encounter secret-mongery in its fullest

bloom—in its most full-fledged development. All ken and cunning is here based upon antique traditions, and the good old customs of the grandfathers and fathers of the trade are sacredly adhered to by the successor. Every one of the latter possesses a chip of the philosopher's stone, and the divers trade secrets are guarded by them with a jealous care that seeks its equal. The endeavor to propagate among them our trade publications, advancements and improvements simply provokes a commiserating shrug of the shoulder; of course, they understand the thing much better; no one would publish a method or process really worth anything; they, of course, would not think of writing Excelsior's "Hints on Watch Repairing," or McGee's "Handbook to Goldsmiths;" these are merely abnormal idiots; they opine that if one were reduced to the strait of acquiring anything useful from a trade publication the art would indeed be a fit subject for commiseration; no trade publication can teach them anything.

Against such minds even the gods battle in vain. It would be "love's labor lost" to attempt their conversion, and it is no wonder if such obtuseness and obstinacy, when compelled to battle with intelligent competition, is crowded to the wall after a little struggle.

Happily, death is decimating their numbers. The younger crop of workmen is already more imbued with the spirit of the age, and less wedded to antiquated prejudices.

This, the close of the nineteenth century, does not longer admit of trade secrets and musty old traditions.

---

### Obituary.

---

GEORGES-AUGUSTE LESCHOT.

It becomes our sad duty to chronicle the death of one of the most eminent horologists of Switzerland, Georges-Auguste Leschot, who departed this life at Geneva, Switzerland, on February 4, 1884, at the ripe age of 84 years. He was justly celebrated in his own country as an able mechanic and inventor, and one whose name will for all time to come be illustrious as one of the chief promoters of the progress of Geneva watchmaking during the first half of this century.

His appreciation of the excellency of the anchor escapement led him, in 1825, to so highly perfect it that from thenceforward it has been adopted as the leading movement of watches. He invented and constructed a series of watch machinery for the world-renowned horological firm of Vacheron et Constantin, for which he received the gold medal of the value of 600 francs, being the prize established by Prof. Auguste de la Rive.

In 1851, Georges-Auguste Leschot was elected a member of the Swiss Société des Arts.

In 1833 he discovered various marks of tools on a very hard piece of antique Egyptian porphyry, and knowing that they could not have been made by a steel tool, he was led to infer that diamond tools must have been used by the ancient Egyptians. His attention was re-directed to the subject in 1862, in answer to an inquiry as to what tools would be suited best for cutting the extremely hard rocks in tunnels, and he then invented and perfected the diamond drill which has been used so successfully in boring tunnels both in America, and, in fact, all over the world.

His two sons died several years ago, and he had the further great misfortune of losing his life companion a few years ago, after which life possessed no further charms for him, and the gnarled trunk bowed before and finally submitted to the storm of time, mourned by his compatriots as well as by all other nations, because genius, though born in a certain country, pertains to every clime and nation.

We most sincerely regret the loss which the horological interest of Switzerland has sustained in his death.

JOHN W. KING.

Col. John W. King, a well-known jeweler of Jacksonville, Ills., died at his residence in that city March 4. For several years the deceased had suffered from an acute inflammation in the inner ear which developed into an abscess of so painful a character that death was welcomed as a release from his earthly sufferings. The deceased was born in Westfield, Mass., and at the time of his death was in the 49th year of his age. He leaves a wife and one child and a host of friends who sympathize with the bereaved ones in their affliction. The deceased was one of the early members of the Jewelers' League.

---

### Size of Spectacle Glasses.

THE QUESTION is frequently asked by spectacle wearers, especially older people, whether spectacles with large glasses are not better than those with small ones. There is but one advantage in having large glasses, and that is when the spectacle frame does not fit the face and the center of the lenses do not come opposite to the pupil of the eyes. Three-quarters of one inch is plenty large enough when set in frames that cause the center of the lens to come opposite the pupil, for the following reasons: In the first place the glasses being small they can be much thinner—a very decided advantage; secondly, only about one-quarter of an inch of glass can be used, because we cannot see distinctly through a glass except we look straight through and not obliquely, hence all spectacles and eye-glasses should be worn at the same angle that we generally hold the print or the paper that we are reading or writing upon; thirdly, a great many back rays of light passing over our shoulder on the glasses, are sent back into the eyes and never pass through the glass, which fact can be illustrated by having all of the lens that we do not use ground gray and not polished, then we will find that we see clearer and sharper through the same lens because there are fewer rays reflected from the polished surfaces of the glasses into the eyes. The great objection to these glasses are that they do not look quite so nice and they are more difficult to keep clean.

A great many spectacle lenses have their edges polished; it adds to the beauty but detracts from their usefulness. Many more reasons might be cited why large glasses are not good, but sufficient have been given to show the advantages of small glasses. The very pertinent question might be asked: What is the use of putting glasses on a man's forehead or cheek—the places where a great portion of the large glasses go. A great many frameless spectacles and eye-glasses are now worn and are very neat and clean. They can be washed with brush, soap and water, but the edges of the glasses should never be polished.

---

HEREDITARY SHORT-SIGHTEDNESS.—Dr. Coha has, in a recent number of the *Gesundheit*, summarized various statistics on the question of hereditary short-sightedness, which have, from time to time, been collected by Erisman, Scheidling, Pflüger and other authorities on the subject. The researches of the last named writer resulted in the following facts being elucidated as to the percentage of short-sighted pupils: Public schools, without predisposition, 8 per cent.; with predisposition, 19 per cent. Higher schools, without predisposition, 17 per cent.; with predisposition, 26 per cent. The difference of about 10 per cent. in favor of those children without an hereditary predisposition to short-sightedness is, according to Pflüger's opinion, a reliable basis of argument. At the same time he asserts that this relatively low figure is arrived at after the necessary elimination of those cases where the predisposition has remained latent, and where it is of such a nature as only to become the source of ocular affection under circumstances of an unfavorable character.

## A New Barrel Arrangement for Clocks.

## Foreign Gossip.

IN THE November number of last year's *Revue Chronométrique* an arrangement was described under the heading "Going Barrel," which permits the taking out and replacing of the barrel of a clock, etc., without the necessity of taking down the movement. The principle of this arrangement is based upon the disposition that the spring core is throughout its length provided with a square hole in which the equally square winding square is fastened in such a manner that it may be drawn out at option.

Ingeniously conceived though this device is, still its correct execution offers serious difficulties, wherefore a young watchmaker, Mr. Leon Bonhomme, proposed another arrangement for effecting the same purposes in said issue. Its practical execution appears to be more simple, and we therefore lay it before our readers.



As will be seen by the accompanying cut, he leaves a heavy shoulder *A*, of the same diameter as that of the pivot of the spring core, to stand on the winding pivot at the beginning of the square *C*; this then filed down at *a* to the same thickness of the winding arbor *O*, which, in place of being square, as above mentioned arrangement, is here round, and the spring core is simply drilled through for the reception of the arbor. An incision is next filed square over the first pivot of the spring core, in which the part *a* of the winding arbor is inserted like a pivot in the pivot hole, so that it forms a firmly united piece with the core.

Of course, also, this disposition requires a very exact execution if it shall render good services, and in place of the iron generally employed at present for the purpose good steel will have to be used.

## Improved Regulator.

THE *Revue Chronométrique* contains an improved regulator arrangement by M. M. Henry, with which he, according to his opinion, obtained such excellent results that the little additional labor bestowed upon the construction of the improvement is amply repaid.

The advantages obtained are said to consist of the following:

First, it prevents the pinching of the balance spring between the pins, and, second, it permits a greater extension of the circular motion of the regulator, and thereby the greater security in the control of the balance spring during the time of performance of the watch up to cleaning.

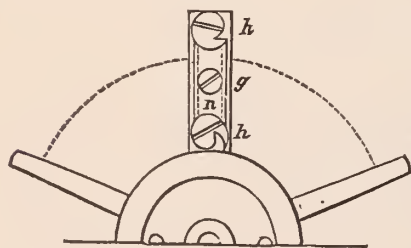

Accompanying cut shows the new arrangement.

A rectangular incision is made in the head of the regulator, into which the piece with the two pins is fitted, which, however, is not visible in the cut, being covered by the part *n*. Both parts are in such a manner kept

together by the screw *g* that the part in which the curb pins are fastened can be pushed backward and forward in the incision, after which it is kept in position by drawing on the screw *g*. By the two cams *h h*, which are below fastened with pins, and embrace the outer ends of *n*, the correct placing of the movable piece is effected before being fixed by screw *g*.

The regulator, in place of the ordinary long index, has several shorter arms, which form a kind of star, and facilitates a greater circular motion toward "advance," as will be seen by the dotted circle of the cut.

ENAMELING.—A patent has been taken out in Germany for a new process of enameling ceramic articles. The glass, terra-cotta, stoneware, porcelain or similar article is covered with a film capable of conducting electricity, by painting the article with a solution of chloride of platinum or nitrate of silver, and burning this in, and then decorating as desired with enamel. This is burned in and the article is afterwards covered electrolytically with the metal. The galvanic coating does not adhere to the enamel, and very varied effects can be produced by gilding, silvering, coloring, polishing, platinizing, etc., the metallic surface of the articles.

STEALING A STEEPLE CLOCK.—In the following incident we do not know what more to admire, the adroitness of the thieves or the watchfulness of the authorities. Everything is possible in Russia, even the blowing up of a czar; but the stealing of a large steeple clock, I presume, belongs to the extraordinary occasions. Russian exchanges a few months ago reported the theft of the large clock from the steeple of the St. Petersburg and Warsaw R. R. depot, committed in broad daylight in the center of one of Europe's largest cities, and in sight of the officials and watchmen. The report attracted great attention and of course much merriment. The watchfulness of the guards, several of which were stationed at every door of exit, was drawn into question, police and detectives were set to work to ferret out the fate of the clock, but it is up to the present chiefly noted for its absence.

THE STANDARD MERIDIAN.—The general conference of the International Geodetic Association held at Rome, to discuss the question of an initial meridian for the unification of longitudes, and for the unification of time by the adoption of a universal hour, presented a report in favor to the special committee, and it is understood that the selection of Greenwich for the meridian was accepted by six to one. Greenwich time for the universal hour was adopted unanimously, but on the question of noon or midnight there was a division of five against two. The longitudes will thus be reckoned from Greenwich, in one direction from east to west, from  $0^{\circ}$  to  $360^{\circ}$ ; and the mean noon from Greenwich will thus correspond with midnight at  $180^{\circ}$ , where the date will change. As the United States, Germany, Austria and Italy use the Greenwich meridian in navigation, Dr. Hirsch was probably correct in saying that 90 per cent. of navigators calculate their longitude from Greenwich, and as so strong an expression of opinion was elicited, the way is paved for a settlement of the question at the International Congress to be held at Washington next year.

WEIGHTS AND MEASURES.—An English visitor who has inspected the office of weights and measures at Sèvres, France, is in ecstasies over the infinitesimal quantities of differences that can be detected by the comparison of the scales. He says that there can be no doubt that in the construction and arrangement of the comparing rooms, and in the design and use of the comparing apparatus, the office at Sèvres has made important advances toward that high accuracy of work which science now demands. With the means there provided it is possible, for instance, to ascertain a difference between two kilogram (each 2.205 pounds), weights so small as 0.00000003 kilogram, or less than a three hundred millionth part of the whole weight. In the comparison of two meters (each 39.37 inches), a difference so small as 0.1 micron. (0.0001 mm., 0.0000039 inch) could be determined. At the English Standard's office, which is, perhaps, as well equipped as the best offices of other governments, it is at present not possible, with the microscopic apparatus alone, to ascertain differences in kilogram weights smaller than 0.00000005 kilogram, or the twenty millionth of the whole quantity weighed; or the difference between the two measures of length amounts to 0.0000095 inch.

## Problems in the Detached Lever Escapement.

BY DETENT.

IN OUR last article we completed our model, and now by good rights we should spend a month in studying its workings when all the parts are correct both in proportion and position. But the first problem we will take will be to assume our escapement depth is too shallow, *i. e.*, the tooth as it leaves the impulse face of the pallet last engaged did not carry the pallet against which it acted far enough so that when the tooth, which was to engage the opposite pallet, instead of striking on the locking face actually struck the impulse face, and instead of our escapement being a dead beat is precisely the old recoiling beat, and the consequence is the guard pin rides the roller. Sometimes, in actual practice, the tooth which has just fallen to the pallet will really strike the pallet very near the angle formed by the meeting of the locking and impulse planes, but the action of the jewel pin in the fork will carry the pallet over and leave the tooth securely resting on the locking face. Here comes up a point which often occurs in our experiences; we have a rather fine English lever in hand, and remove the balance and put some

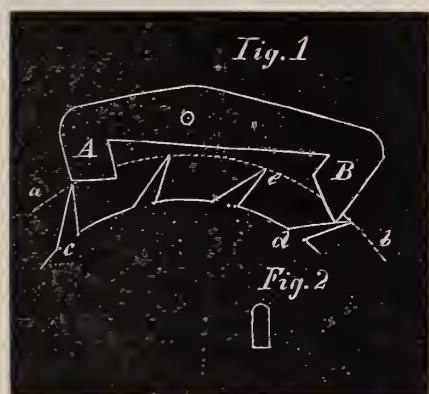

light tool like an oiler in the fork of the lever, and move it back and forth and find on several of the teeth that the drop is too soon, and the locking face of the receiving pallet is not in position to receive the tooth which is to engage it. Even still more marked cases have come under the writer's notice; an escapement so shallow, that if the banking pins were closed into the drop the escapement would run the watch down, the lever vibrating with intense rapidity until the power of the mainspring was exhausted. And still put the balance in and the watch would beat perfectly clear and give no indications by sound of the guard pin riding the roller. And neither did it; for in actual results the jewel pin had carried the fork and pallet far enough over during the time the scape wheel had traversed the two degrees of drop, that the tooth actually found nearly its true position on the locking face. Still such conditions cannot be considered as sound and safe in an escapement; but it is equally true they are factors in questions involved in these problems. The reader would do well to read the article in December, 1883, number of this journal, where a similar condition is spoken of. At this point, and while considering the action with the factors above mentioned in view, would it not be well to ask ourselves if it would not really be the best policy to increase our arc of impulse and diminish our lock—or to take a broad view of the case—diminish our arc of lever action to 9 degrees instead of 10, for we well know that the more we emancipate our balance from the escapement the better. If we diminish our lever action to 9 degrees can we not safely (in view of the facts above cited) leave our impulse at 8 degrees, allowing only 1 degree for lock? Here we have our model; we can very easily realize these conditions, for if the reader has paid strict attention to the rules given he can correctly draw pallets of any number of degrees of action. And with the model he can put the thing to the severest tests. His balance is the same weight, controlled by the same pendulum spring, the same weight propels the escapement. Now, compare the two escapements and judge by the arc of vibration of the balance as to which gives the best result. But to resume the

problem in hand, *i. e.*, too shallow deeping between the pallets and scape wheel. Now, this seems as a very simple question; yet it can involve a great many conditions, and the *apparent* shallowness of the escapement may result from other causes than the center of action of the pallet staff being too far from the center of the scape wheel arbor. We will first suppose the watch was correctly made (and it was to this view that the writer has so strenuously urged the making of a model correct in every way of a lever escapement), and that some incompetent workman has been tampering with the scape wheel. In the present case let us assume there has been a new pinion put in the scape wheel, and that the workman did not succeed in getting his pinion in true (a very usual fact), he now *taps off* the teeth—very likely rounding up the points of the teeth (fig. 2) to avoid “friction” until he gets his scape wheel too small. If our *quack* stopped here the remedy is simple enough; all we have to do is to put in a new scape wheel of the correct style. A few words in regard to scape wheels and we will go on with our problem. Workmen who live at some distance from large stocks of scape wheels should keep a good supply on hand of the commoner sizes, letting extreme sizes (either large or small) be in the minority. If you have one of the correct size all right put it in; if not, select one the nearest you have *larger*. Set the wheel on the pinion and true it up. Next take your deeping tool and set the points so they correspond to the holes in the plate. Some little judgment is required to set a deeping tool to exactly represent the distance between the two holes; the best way is to take the inside of the top plate (to an English lever), and set the points as near correct as the judgment will be right; next set one of the points in one hole and with the other sweep a short circle crossing the other hole; then with a double eye-glass determine if the line crosses exactly the center of the hole; if not set the deeping tool until it does. Put in your scape wheel and pallets and try the depth, first by turning your scape wheel backward; if the scape wheel is entirely too large the wheel will not turn. Of course, judgment must have been exercised in not selecting a scape wheel disproportionately large; still if the instructions here given are lived up to, a wheel seemingly much too large can be used. Don't let the reader imagine the writer recommends this course as the *best*, for he does not intend anything of the kind; he only gives this as a method by which a fair result can be obtained by persons so situated as to be limited in their resources. If the scape wheel will not turn backward and indicates the wheel being too large, remove the lever from the deeping tool (but be careful not to change the depth), and insert a slip of Arkansas stone so that it will be held steady, and with the finger revolve the wheel so as to grind off the ends of the teeth. This should be repeated until the wheel turns freely backward. Next comes the testing for the lock; this is a delicate manipulation not difficult to do but somewhat difficult to describe. Let us suppose we turn the scape wheel backward so the back of a tooth acting against the egress pallet shown at *B*, fig. 1, will cause the ingress pallet *A* to advance the impulse face of (ingress) pallet *A*, inside of the circle *ab* (a line corresponding to the ends of the scape teeth). The scape wheel does not want to be turned back until the tooth *d* passes the angle of *B*, but only enough so that when the scape wheel is turned forward the tooth *c* will engage the impulse face of *A* somewhat near the middle; if now the scape wheel is moved forward until the tooth *c* leaves or drops from the pallet *A*. If everything is as it should be the tooth *c* will fall safely on the locking face of the pallet *B* and *draw* it inward. Both pallets can be tested by this system, only reversing the order, letting the back of the tooth *c* strike *A* so as to let the tooth *c* strike the impulse face of *B*, and bring the locking face of *A* into action in the same manner as we did *B*. This process can be repeated until every tooth is tested as to lock and drop. After the teeth are stoned off to the correct length they can be dressed up to a point by a slip of Arkansas stone; but only stone the back of the tooth, leaving the front intact. Of course skill and judgment must be used to preserve the correct form of the tooth. But never round up the point of the tooth as shown (enlarged) at fig. 2.

## Advice to Watchmakers' Apprentices.

BY A MAN WHO HAS SPENT TWENTY YEARS AT THE BENCH.

FLAT LAPPING can be done by means of flat laps worked back and forth; this makes the finest work but is slow. The principle on which this work is done lies in making use of a plane surface, which may be divided into parts, but still all the component parts present their surfaces in the same plane. To illustrate, suppose we have a piece of cast brass shaped as shown in fig. 1, about 5 inches long and  $\frac{1}{4}$  of an inch thick. In the cut (fig. 1) the upper figure shows a plan of the pin and diagram  $A^*$  an edge view. The parts  $a b c$  are raised above the surface of  $A$  as shown in diagram  $A^*$ . It is evident on inspection of this diagram that the surfaces of  $a b c$  are exactly in the same plane. This feature is indispensable if we wish to change from one piece like  $A$  to another. As, for instance, we have two pieces like  $A$ , one for grinding and one for polishing; if both are common to a plain surface as on the dotted line  $d$ , they can be used alternately and act alike on any surface to be ground or polished. At fig. 2 is shown an elevation of the apparatus for holding the work. The bed piece  $E$  is triangular and shaped as shown in fig. 3. It should be made of cast iron and about 10 inches on the sides by  $\frac{1}{2}$  inch thick. The object in making it so large is to have it heavy and consequently steady. Such a grinding device is by no means confined to polishing gold and jewelers' work, but many jobs of watch work. Underneath the cast iron bed  $F$  are three feet  $f$ . Passing upward through the bed  $F$  are 4 screws  $i i i i$ ; these screws press against a plate of metal  $n$  about 2 inches square; this plate should be thick enough to be rigid, and of brass  $\frac{1}{8}$  of an inch thick.

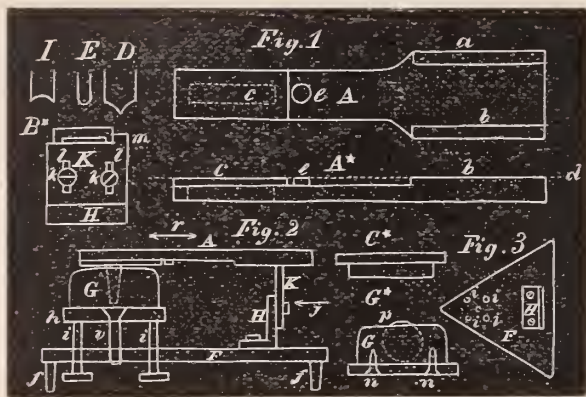

The screw  $v$  has a bevel head in the plate  $h$  and is tapped into the bed pin  $F$ . It will be seen that by means of the screws  $i i i i$ , the plate  $n$  can be tilted to any angle within moderate limits. Secured by 2 screws to the bed  $F$  is a piece of heavy brass bent at right angles as shown at  $H$ , figs. 2 and 3. To this piece ( $H$ ) is attached, by the screws  $k k$ , a plate  $K$ ; the screws  $k k$  work in the slots  $i i$ , so that  $K$  can be moved up and down. As we have in former articles been using a ring to illustrate, we will continue to do so in this and take the upper portion of a shank as the part we wish to lap. The block  $G$ , fig. 2, can be of wood with a mortise to receive the ring as shown in diagram  $G^*$ , this can be secured to the plate  $h$  by two wood screws as shown at  $n n$ ; a cement of clear rosin and sifted brick dust will cement the ring in  $G$  with but a moderate heat. The ring is now in the position shown at  $p$ , diagram  $G^*$ . We now place the block  $G$  as shown in fig. 2, and by means of the screws  $i$  bring the surface we wish to lap horizontal. The piece  $A$  is applied as shown in fig. 2, the parts  $a b$  resting on  $K$ . Now, by shifting  $K$  for larger inaccuracies and manipulating the screws  $i$ , the surface of the ring can be brought to exactly correspond to the surface  $c$  on the grinder  $A$ . If now the piece  $A$  is moved back and forth in the direction of the double-pointed arrow  $r$ , fig. 2, and the surface of  $c$  is smeared with fine glass and oil the surface at  $p$  will soon be ground perfectly flat. If now the work is cleaned with bread crumb (fresh bread worked into a putty-like mass), and the diamantine and oil applied with  $A$ , number two, a brilliant mirror-like surface will quickly appear. The part  $c$  of  $A$  should be of block tin. A more minute description of how the part  $c$  is secured to  $A$  so the surfaces of  $a$  and

$b$  will be in exactly the same plane as  $c$  will be needed. As mentioned above the part  $c$  should be made of block tin cast nearly in shape, when it can be filed and scraped into the exact form desired. As it is desirable to change the part  $c$  frequently, we should seek to arrange it so as to be taken away and put in place readily. In the end of  $A$  at  $c$  will be noticed a mortise in dotted lines; this mortise is cut quite through  $A$  and a projection on  $c$  is loosely fitted to this slot or mortise. The reader will notice at  $c$ , fig. 1, a projection; the upper surface of this projection is flat and is exactly in the plane of the surfaces of  $a$  and  $b$ . Suppose, now, we wish to take out the piece  $c$  and restore it so that its face is again exactly in the same plane as  $a b$ . We smear the mortise in  $A$  (after heating it) with the cement made of the best rosin, 1 part; fine sifted brick dust, 2 parts. The brick dust should be sifted through a very fine sieve; a small one made of fine Dutch bolting cloth is the best. This cement is melted at a temperature below boiling water. The piece  $c$  is inserted in place but not quite forced down to place; a piece of thick plate glass is dipped in boiling water or otherwise brought to this temperature. The piece  $A$  is now laid face down on this bit of plate glass and pressed down, when it will be seen that the projection  $c$  will only permit  $A$  to go so far and the surfaces of  $a b$  and  $c$  will again be in the same plane. After  $A$  is cooled it can be used for lapping as directed. A flat surface is not the only kind which can be used at  $c$ ; but others, some of which are shown in section at  $D E I$ . The caution must now be kept in mind to keep the surface of  $c$  in the same plane. The projection at  $m$ , diagram  $B^*$ , is used as a side guide to  $A$ . The cement of rosin and brick dust must be used in such a manner as not to injure or depolish such surfaces as are already polished; but if the coating of shellac is put over the work it will protect it, and the cement of rosin can be dissolved with spirits of turpentine and washed off without disturbing the coat of shellac. The writer wishes it distinctly understood that he does not recommend such a system of polishing except for some part or parts on which it is desirable to have a surface as flat and brilliant as a mirror. By the judicious use of laps of different forms almost any part of a diamond setting can be ground to exact form and perfectly polished without rounding the angles. The piece  $G$  can be made of two parts and clamp together with screws, and in this manner dispense with any cement; but even then the coat of shellac dissolved in alcohol will be well to preserve the surface. These articles on jewelers' work have already extended to some length and still one-half is not told. The writer has sought as much as possible to avoid giving methods which are in common use, deeming those as already known to his readers. But rather sought to give new methods which could be reached by the artisan of moderate means. Early in these papers we gave the formula for alloying a gold 20 dollar coin to 18 karat. In our next issue we will give the rules for compounding alloys of any quality. Our feature of all the systems of alloys given in our books on the subject (as far as the writer has seen) speak of alloying with pure gold, or else gold of the English standard. What we want here in this country is how to use gold, coin ( $\frac{900}{1000}$ ) fine, so as to produce exact results. As, for instance, we have 36 dwt. of 10 karat scrap which we want to bring up to 14, 16 or 18 karat, as the case may be; now how much gold coin of the U. S. standard must we use? In our next we propose to give a simple rule for these calculations as well as colored alloys.

MEDICAL.—We believe Talleyrand is credited with having said that "there is but one step from the sublime to the ridiculous;" we for the nonce forget horology and goldsmithing, and turn our attention to medical statistics. The *Giglio Medico* gives the proportion of doctors to the population in different countries as follows (the proportions are to 10,000 souls): France, 2.91; Germany, 3.21; Austria, 3.41; England, 6; Hungary, 6.10; Italy, 6.10; Switzerland, 7.06; United States, 16.24.

## Trade Gossip.

Bracelets for gentlemen are among the leap year jewelry.

Providence jewelers manufactured \$5,444,092 worth of goods last year.

The firm of P. Copeland & Co., of Marshal, Texas, has ceased business.

The Silver Plated-ware Association at a recent meeting, resolved to reduce the price of flat ware  $7\frac{1}{2}$  per cent.

Small headed diamond pins, pearls, gold and silver pins are thrust about in the laces of jabots and frills on dressy corsages.

Shell hair pins, with glittering Rhine stones in the curved end, are worn as ornaments, thrust through the coils of the back hair.

O. G. Martin, jeweler and bookseller, of Blythe, Canada, has been arrested for counterfeiting paper money by a patent photographic process.

The southern country has this season been overrun with jewelry and spectacle peddlers, and the price of fire arms and savage dogs has advanced accordingly.

Thomson & Reeser, of Lancaster, Pa., offer their entire stock of jewelry at public auction to close up their business. Col. J. M. Ruth-erford is conducting the sale.

The firm of Hessels & Ludeke has been dissolved by mutual consent, Mr. Hessels retiring. The business will be continued under the firm name of Ludeke & Co.

An enterprising manufacturer has recently introduced a new style of sleeve button with raised gold designs representing the Brooklyn Bridge. The sun represented by a diamond sunk in the surface.

George G. Peck, a watch and jewelry repairer, is wanted in Den-ison, Texas, for alleged theft. He is described as about forty years of age, 5 feet 7 or 8 inches high, dark complexion, brown hair and eyes; he speaks German and a little Spanish.

The firm of Sussfeld, Lorsch & Nordlinger has been dissolved by reason of the death of Mr. Nordlinger. The business will here-after be conducted under the firm name of Sussfeld, Lorsch & Co., at the established places of business in New York and Paris.

Keller & Untermeyer have just completed a very elegantly dec-olated watch case, the decoration consisting of a wreath of diamonds interspersed with rubies, the latter gems serving to heighten the effect of the diamonds, and to render the whole a work of taste and elegance.

The application of S. Rothschild, of Memphis, for a new trial has been overruled. It will be remembered that he was convicted of sequestrating his goods and sentenced to three years imprison-ment. There seems to be little doubt but he will have to serve out his sentence.

Aikin, Lambert & Co. recently received an order for a live monkey. A reply was sent to the effect that they had no live monkeys in stock, and asking if a "dude" wouldn't do. The answer to this was that while "dudes" might be ornamental in Broadway, the customer wanted something with brains in it.

The coral industry on the Algerian coast is now regulated by a decree of the French Government. In future the fishing for coral must no longer be conducted with the use of apparatus made of iron or other metal, as it is supposed that implements of this nature tend to destroy the reefs and prevent their reproduction.

A new finish suitable for rings has been introduced by William C. Edge & Sons. It is called *alto-relievo*, and consists of a sunken center with raised ornamentation in various colored gold on a stone surface. The edges of the ring are raised so as to protect the orna-mentation. It makes an admirable glove ring. The same goods are made in lockets. The design is attractive and desirable, and is pro-TECTED BY PATENT.

Beside the real, and certainly very expensive Renaissance jewelry, fancy ornaments are especially in vogue. One unique watch chain consists of four cords joined together by the silver mounting, having at one end a pocket compass, and at the other a short chain with swivel. The droll pendant showing on one side a laughing full moon face, and on the other an equally melancholy countenance, is made of oxidized silver. The large tortoise shell hair pins have their effect heightened by the addition of the top being gilded.

An individual calling himself "Webber the Jeweler," of Flushing, Long Island, has been sending circulars to the trade, claiming a copyright on a round printed card containing a railroad time table and an advertisement. It is intended to be placed inside the case of a watch. The idea is old as the hills almost, and his claim to a copyright on it is not likely to be sustained in any court.

Attention is directed to the illustration that appears in this issue of the new building just completed by the Gorham Manufacturing Company, at the corner of Broadway and Nineteenth street. Also to the new building corner of Seventeenth street and Broadway, which will shortly be occupied by several prominent members of the trade. In a future issue we shall give a detailed account of these very elegant buildings.

The estate of the late John Lazarus, of New Orleans, is announced, on the authority of the attorney in the case, to be entirely solvent. Creditors are requested not to permit his paper to be protested, and assurance is given that all liabilities will be liquidated as soon as the administrators can get the estate in proper shape. Mr. Lazarus was an old and well-known jeweler, and stood high in the estimation of the trade. His representatives will con-tinue the business.

V. S. Cooper, of Princetown, Ills., recently sold a five minute repeater to a blind man by telephone. The customer wanted a minute repeater the tone of whose bell should be clear and distinct. As he lived at some distance, the repeater was placed near the tele- phone transmitter and caused to strike. The blind man, after several experiments, was satisfied with the tone of one of the watches and gave an order for it by telephone—the same means used to ascertain its merits.

The old familiar bill which is intended to destroy the manufacture and sale of gold and silver goods in this State, has again made its appearance in the legislature. It turns up every year or two, when some one thinks the time favorable for making a "strike" on the jew-elry trade. Fortunately there are members of that body possessed of sufficient intelligence to see the evil effects of such legislation, and the bill met with a sudden death, even the introducer of it becoming ashamed of his offspring.

Mr. Joseph F. Chatellier has just introduced a patent design for jewelry decoration which can be applied to various forms with very effective results. It consists of a centerpiece and a series of con-verging loops of varying lengths and dimensions. This is called a rosette, and is in the nature of a shell, the loops presenting a surface for the setting of gems of graduated sizes or for shot work. The design is very beautiful, and as it can be applied in so many ways it will unquestionably become very popular.

The bill to legalize standard time in the District of Columbia has now passed both Houses of Congress, and will no doubt be approved by the President. The new time had become recognized generally in the city, and the passage of the law will only the more firmly establish the new order of things, and prevent litigation over con-tracts and matters involving the recognition of any specific time. Attorney-General Brewster will now probably gracefully acquiesce in the general desire for a uniformity of clocks and watches.

The approaching sale of the Castellani collection at Rome absorbs the interest of the archæological world. Though the late Signor Castellani sold from year to year an immense number of valuable objects, he retained in his own possession many of the very choicest treasures. Mr. Newton, of the British Museum, is about to make a journey to Rome, armed, it is said, with large powers from the trustees, and the South Kensington authorities have taken care to be represented at the forthcoming contest. Some of the gems of the collection may go to England.

The fifth annual meeting of the Jewelers' Protective Union was held at the rooms of the Jewelers' League on March 3d, with a fair representation of members of the trade. The Secretary presented a very gratifying report of the affairs of the Union, the expenses hav-ing been comparatively light during the past year, and the funds increased accordingly. The organization have now out 406 cer-tificates protecting the stocks of merchants while in the hands of travelers while on the road. Robberies of travelers are becoming a thing of the past, indicating that the severe punishment meted out in such cases heretofore has inspired thieves with a wholesome dread of the Union. Mr. Wm. R. Alling was re-elected president, and Mr. Ira Goddard, Secretary, and the old Executive Committee was continued.

Finger rings for gentlemen are round heavy circlets of dull or antique finish, or have a hammered gold surface set with sunken stones, cut or *en cabochon*, diamonds, cat's-eyes, opals, moonstones and sometimes with a trefoil in which a ruby, diamond and blue sapphire appear. Scarf pins are in infinite variety and are fashionable with high buttoned coats. The plain gold head or single jewel scarf pins are worn by gentlemen of quiet taste, diamonds and pearls being the most fashionable. In the more fanciful styles are diamond flies, spiders, elephants with bodies of pink pearl and golden heads, owls in richly colored Limoges enameled, with staring diamond eyes, irregularly shaped pearls, diamond horseshoes, small golden horses, dogs and other animals, and even the opal, the superstition attached to which is gradually disappearing. A beautiful and costly scarf pin is set with a black opal in diamonds. The green play of light upon the dark mysterious surface is most uniquely beautiful.

Until the South African mines were discovered the diamond was always found in sands and gravels, different from the mineral in which it was believed to be formed. At Griqualand West, however, the consolidated eruptive mud of the mines was believed by some to be the true matrix of the diamond; but opinions differed on the question, and arguments were found on both sides. M. Chaper, a French geologist, has, however, during a scientific mission to Hindustan, succeeded in finding the diamond in its mother rock. At Naizam, near Bellary, in the Madras Presidency, M. Chaper has found the diamond in a matrix of rose pegmatite, where it is associated with corundum. The tract of country is almost denuded of trees, bare and rocky, and the rains wasting the rock every year expose fresh diamonds in the soil. The rock is traversed by veins of feldspar and epidotiferous quartz. Here the diamond is always found, associated with epidotiferous rose pegmatite. The diamond crystals observed are octahedral, but less distinct in line than the stones of South Africa, which seem to have been formed in a freer matrix. It follows from M. Chaper's discovery that diamonds may be looked for in all rocks arising from the destruction or erosion of pegmatites, for example in quartzites with or without mica, clays or pudding-stones.

M. S. Smith & Co., of Detroit, have recently opened what is unquestionably the finest and most attractive jewelry palace in this country. The building is located at the corner of Woodward avenue and State street, and was erected by the firm especially for their own occupancy. All that architecture and art, together with a liberal expenditure of money, could do to make their establishment convenient and attractive has been done, and their store is now one of the "sights" of that prosperous city. At one of the entrances is a magnificent and unique clock that was built in Europe last year under the personal supervision of Mr. E. J. Smith. The dials, lighted by electricity at night, face up and down the avenue; above them stands old Father Time with his scythe and hour-glass ready to strike the half-hours on a large bell. Opposite him stands a smith at his anvil, who strikes the quarter hours on a second bell; while the hours are struck on a third bell. On the State street side is 48 feet of mahogany casing with plate glass front lined in black and lighted from the top by six bracket lights. There are also two other smaller but similar receptacles for the goods on display lighted by toilet jets, while in each department tables will be placed for the exhibition of clocks, bronze goods and statuary. Here, as throughout the establishment, the fittings are of solid mahogany with San Domingo mahogany veneering, and there is noticed the same taste that leaves no striking feature, no peculiarity, no defect to detract from or mar the pleasing effect. Even the finish of the six chandeliers suspended from the center show the same style of ornamentation and workmanship as the metallic pillars on either side. The interior decorations were under the sole supervision of W. B. Smith of B & W. B. Smith, New York, the well-known decorators and manufacturers of show cases. Their work has been done with a degree of taste and elegance that has never before been equaled. Mirrors and plate glass abound, while rich curtains and soft drapery tend to relieve and beautify the rich wood work. There are no sales counters in the establishment, but the goods are in glass covered cases and cabinets where they make an attractive exhibition and are easily accessible. Each class of goods has its respective department, and convenient elevators convey visitors from one story to another. At night the store is brilliantly lighted with electric lights, and the brilliancy, reflected and intensified by the display of rich goods, makes a fairy scene the like of which can be witnessed nowhere else. The American Morocco Case Company furnished many of the trays and cases for the exhibition of goods. The entire establishment is a worthy monument to the energy, enterprise and capacity of the gentlemen comprising this well known firm.

The tea prize company that came to grief in Pennsylvania a few days ago, because some of its victims asserted that the alleged watches and silverware distributed as gifts in the cans were nearly worthless, and some of the coffee and tea possibly a little worse than worthless, only tested afresh the gullibility of many purchasers. Apart from the breaking of law in that lottery business, it should have been suspected that the tradesmen could not sell a good pound of tea for its usual price and a valuable piece of silver or jewelry to go with it. But the curious propensity of many persons for getting a wonderful prize gratis, at the risk of sacrificing full worth in the commodity they really need, furnished plenty of buyers to the Pennsylvania concern until its tricks were discovered.

The firm of Cross & Beguelin of this city, have recently received an invoice of J. Alfred Jurgensen's complicated watches, and also a copy of the diploma of honor that has been granted to him by the jury at the exhibition of Zurich, held in 1883, for the superiority of these movements. One of these watches is a marvel of ingenuity. It has a double dial back and front; one records the time in the usual manner, while the other is arranged on the twenty-four hour plan, each indicating separate time. Another is a split independent fifth second fly-back, with a double timer which is a horological wonder. Another is a self-striking repeater, striking the hours and  $\frac{1}{4}$  hours automatically. There is also a fifteen line minute repeater which is one of the smallest ever exhibited in this market. Among the importations are also a number of chronometers that are perfect in every sense of the word.

"Cliff" Booth, traveler for Fowler Bros., is well-known as one of the most genial men on the road, an excellent story teller, fond of a practical joke, and an expert in the use of the negro dialect. He abounds in stories full of African humor, and is never happier than when discoursing to an appreciative circle of friends and fellow missionaries. He is also a capital actor, and with facial emphasis and eccentric gesticulation can discount any of the professional minstrels in the rendition of negro character. Recently one or two of his friends resolved to secure for him an audience worthy of his talent, and at the same time give him an opportunity to compete with native African talent. Accordingly they organized a cake-walk at a neighboring village, where prizes of jewelry and silverware were offered for the most expert professors of the toe and heel philosophy. Several distinguished colored citizens of the village were announced as judges of the contest, and conspicuously displayed in the posters as the most distinguished of these judges was the name of Hon. G. Clifford Booth of New York, who was also credited with contributing a \$100 prize. On the eventful evening the hall selected was crowded with the *elite* of the colored population; the ebony judges occupied the platform with dignity, while numerous contestants for the prizes were ready to do battle in the cake walk. But the Hon. G. Clifford Booth was not there; he was, in fact, conspicuous by his absence. Instead of his pleasant and open countenance, the audience was forced to accept a letter of regret. He wrote that he had hastily been summoned to Washington to confer with eminent statesmen as to the next presidential candidate, and as there was a good prospect that his name would be used in that connection it was imperative that he should be there to look out for his political interests. Nothing would have given him greater pleasure than to participate in the cake walk; if there was anything he enjoyed more than anything else it was a cake walk; on numerous occasions he had been the victor on well contested fields, and felt that in the glorious art of heel and toe he might be called the champion; but on this occasion he was forced to forego the pleasure such a contest would afford, and would leave to others the decision of the respective merits of the contestants. The letter caused some disappointment, but nevertheless the crowd of dusky males and females gave three rousing cheers for "brudder Booth." The walk proceeded in accordance with the programme, and the prizes were won by the contestants amid intense enthusiasm and great hilarity. The champion of the evening was a fairy, ethereal, saddle-colored damsel weighing 250 pounds. When the cake containing the gold necklace was awarded her, she advanced to the judge's stand, received the cake with many blushes, and a countenance that reminded one of the opening of navigation; when she smiled the top of her head would have been an island but for her ears. Hastily retiring to a corner she tore the cake open, extracted the necklace and immediately sold it for a dollar, much to the disgust of Charles B. Stopplekam, who had generously donated that article of personal adornment. The Booth prize was won by a jet black African dressed in star and stripes costume and carrying an American flag. Financially and socially the cake walk was a success, the only regret expressed being at the non-appearance of the Hon. G. Clifford Booth as one of the judges in accordance with the announcement.





THE

JEWELERS' CIRCULAR AND HOROLOGICAL REVIEW

*The recognized organ of the Trade, and the official representative of the Jewelers' League.*

A Monthly Journal devoted to the interests of Watchmakers, Jewelers, Silversmiths, Electro-plate Manufacturers, and those engaged in the kindred branches of art industry.

SUBSCRIPTION:

To All Parts of the United States and Canada,  
**\$2.00 Per Annum; Postage paid.**

To Great Britain, France, Switzerland, Germany, the West Indies, Mexico, the Republics of South America, and Australia, \$3.00 per annum. Postage paid.

*All communications should be addressed to D. H. HOPKINSON, 42 Nassau Street, New York. Advertising rates made known on application.*

Proposed National Robbery.

THERE SEEMS to be a determination on the part of the present Congress to so amend the existing patent laws as to destroy absolutely all property rights in patents. This would involve the destruction of the rights of inventors, owners of patents, manufacturers of patented articles, and of the capitalists who have invested their money in the construction of special machinery for the production of such articles. Over twenty bills, most of them bad, have been introduced to alter these laws. One of the most striking reduces the life of a patent from seventeen years to five. Another empowers juries to fix the license fees to be paid by users of patent infringements, without regard to the patent owner's valuation of his property right. Another enables any user of an infringement to evade punishment by the simple plea that he did not know that the thing was patented or that the person selling it to him had no right to patent it. Another authorizes the user of an infringement to continue its use where it would be of the greatest benefit to him and most injurious to the owner of the patent, notwithstanding ample legal notice after his purchase that it was an infringement. Then we have bills to compel the owner of a patent repeatedly declared valid by the United States Courts to give bonds for the payment of costs before commencing suit against an infringer; to make the plaintiff in such suits pay all costs if he does not recover damages to an amount seldom reached in such prosecutions, except where the defendant is a vender or a fraudulent manufacturer of the infringement; and to make the plaintiff liable not only for the costs of suit, but for the payment of the defendant's attorney when these and other ingenious devices to thwart justice chouse him out of an award of damages.

Some of the very worst of these bills have already passed the House of Representatives, and are now before the Senate, and whatever efforts are made to secure their defeat must be directed to that body, and that very speedily. The hostility to the existing patent

laws comes mainly from the agricultural districts, where, it is claimed, owners of certain patents have perpetrated many abuses, and succeeded in robbing some of the farmers. There may have been some instances of injustice to innocent users of infringements through the peculiar methods of certain patent owners, either in securing their supposed rights or through the vexatious uncertainties affecting contested ownership of patents. The extent of such injustice, however, has unquestionably been greatly exaggerated. Even at the worst, it is a very small ratio to the patent interest of the country as a whole, or to the benefits conferred upon the people by patented articles. The very farmer who wants the patent laws repealed because he has been swindled by a lightning-rod man, gets his clothes for a less price because they are made by patented machinery, and his crops are planted, protected and harvested at a less cost by the efforts of the inventors whom he now seeks to ruin. The secret of this opposition lies in the fact that the very men who are profiting the most in the use of patented articles want to get them without paying for the use of the brains, intelligence and labor that invented them. In short, they want to rob the inventor and manufacturer of a fair profit on their work, and there are demagogues in Congress who are willing to aid them in so doing. If the evils alleged exist in any degree, they may certainly be remedied by a less radical process than the destruction of all protection for property right in patents. To make laws of the proposed bills would annihilate the owner's benefits on a great number of patents, ruinously unsettle the values of all not made absolutely worthless, and affect injuriously all manufacturing interests dependent to any extent on patented processes or machinery. It is surprising that three members of the Senate Patent Committee, who represent States in which enormous sums of capital are invested in patents, and in which the prosperity of nearly the entire population is intimately connected with the maintenance of the rights of inventors and patent owners, should permit such measures to pass through their hands without careful scrutiny and strenuous opposition. These are questions in which the honor and material prosperity of the nation are opposed by the interests of petty rogues who wish to steal the fruits of others' brains.

Inventors and manufacturers have taken the alarm, and petitions are being circulated for signatures protesting against this outrage. Every person in any way interested in patents, either as inventor, owner, manufacturer or dealer in patented articles should join in this protest, and make his influence felt in the Senate chamber. Petitions are being circulated for signatures asking the Senate to recommit all the bills on the subject of patents to the Committee on Patents, and opportunity be given the other side to present arguments opposed to this proposed destruction of property rights.

Bad Effect of Speculation.

IT HAS been said, with much truth, that the Americans are a nation of gamblers. It would be outside the truth to say that we are all inclined to stake money upon games of chance, but as

speculators our people have not their equals. The operations in Wall street are felt throughout the whole world, and yet these operations are of the most extravagantly speculative character, differing so little from professional games of chance that one is puzzled to draw the line between speculation and gambling. Whatever possesses value affords opportunity for speculation, and hence we find speculators in stocks of all kinds, in wheat, flour, cotton, corn, and, in short, in everything that has a market value. Prices are made and unmade to suit the whims and circumstances of various cliques, and the actual value of the thing itself has little to do in regulating its selling price. The transactions of our various exchanges would be legitimate enough if they were based upon actual values, or if the persons selling owned the articles sold; but such is not the case. In but a very small percentage of these transactions does the article bought and sold pass from seller to buyer. The transaction is, substantially, a wager that the price of the article in question will go up or go down within a specified time, and the loser pays whatever difference there may be between his guess and that of his opponent. This is speculation bald and simple, and we confess that we can see little difference between that style of "business" and betting as to whether a jack or an ace will come first out of a pack of cards dealt by a practised dealer. But it is this speculation, this bogus dealing in articles which the seller does not possess and the buyer does not want to, that keeps our markets unsettled and interferes with legitimate business. During the past few weeks there has been unusual excitement in the grain markets, and prices are so unsettled that a feeling of great uneasiness extends to all lines of business. A dispatch from California, for instance, says that because of the break made in the price of wheat by speculators, the farmers of the Pacific coast have become alarmed and will reduce the acreage of wheat this year. The operations of speculators has also had an injurious effect upon our exports of grain. European nations that were largely dependant upon the United States for bread stuffs, have been so disgusted with the condition of our markets that they have sought their supplies elsewhere, and the demand for our products has greatly decreased. As an illustration: India used to send to England a million bushels of wheat annually; this year she will send over thirty millions of bushels. So with other staple products—the foreign demand is decreasing each year. The buyers of Europe are tired of being bled by our grain gamblers, and have turned their attention to developing the resources of other localities where the conditions are favorable, labor cheaper and speculation unknown. With a decreased foreign demand for our products, prices tremble, farmers are discouraged and general business suffers. Foreign capitalists have long been afraid of our railroad bonds and other securities, because of the manner they are manipulated by speculators in the stock markets. There should be laws enacted making it a misdemeanor for any person to sell or offer for sale any article which he did not actually possess. This would tend to put an end to stock gambling and the questionable transactions of our various exchanges. It would put buying and selling upon a legitimate business basis, and place our products upon a foundation of values predicated upon actual demand.

---

### Cheap Movements.

THE GROWING demand for cheap movements that has for several years been fostered by a certain class of dealers, is likely to result disastrously to the entire retail trade. In pressing manufacturers for a cheap movement they have created a demand for this class of goods that cannot be met by any of the watch companies, for their production of these movements constitutes but a small percentage of their output. Nevertheless, enough of them are made to do serious harm to the interests of the legitimate dealers and tempt outsiders to handle them, and this demand being created

among this class of buyers it is supplied by goods of foreign manufacture. Instead of checking the importation of Swiss movements as was first intended, the effect was directly opposite as the increased importations will show. Now, that the outside trade is seeking these goods, even foreign manufacturers are unable to supply the demand, and the consequence is that schemes are being constantly presented for the formation of watch companies for the exclusive manufacture of cheap movements. If the existing companies, with all their facilities and experience, cannot afford to make this class of goods, how can these embryonic concerns hope to do so? As a result, we have to anticipate the introduction of a class of movements where quality is sacrificed to cheapness, made expressly to satisfy this demand that regular dealers have stimulated and encouraged. The dealers will then find themselves forced into competition with outsiders, who, having no responsibility after selling the goods, can afford to handle a class that would not be profitable for reputable dealers to sell. The public is more exacting of a regular dealer than it is of an outsider, and this fact is brought home to him every day of his life.

The fact is, the cheap grades of honest made American watches are far too good for the money paid for them. The cost of production is so close to the selling price, that the companies cannot afford to make them. They have demonstrated that to run their factories exclusively on cheap movements is to insure a loss; they cannot cheapen the quality of the movements for their reputations are involved; so they find themselves in a sad dilemma. Meantime the dealers continue clamoring for more cheap movements, apparently not realizing that this cry is a club with which they are beating out their own brains, for it is in response to the demand they have created that outsiders have taken up the cheap movements in which quality has been sacrificed to price, and so built up a competition with the legitimate retail trade in which the regular dealers must necessarily get the worst of it. From cheap movements these outsiders have worked into full lines of jewelry, and in every city of importance the dealers have to meet the low prices established by the bazaar men, the fancy goods dealers and others. It is a great mistake for retail dealers to desire a class of goods of degraded standard or such as they cannot conscientiously recommend. When quality is sacrificed legitimate dealers cannot afford to risk their reputations in handling the articles. They are differently situated from the outsiders, who are not held responsible for the quality of the goods they sell, but simply for the price. When a regular dealer sells a watch, whatever price he receives, he is considered to have guaranteed it, and if it proves unsatisfactory he is blamed and his reputation suffers. He ought, therefore, never to handle one he cannot conscientiously recommend. When he does, he places himself on a level with the outsiders, who have no reputations to maintain. If dealers will confine themselves to handling in future only legitimate goods they will gradually win back much of the trade that has drifted away from them; but the more they stimulate the demand for cheap movements the more they play into the hands of the outsiders and embarrass the manufacturers of standard goods. The legitimate companies cannot supply this demand, and the more forcible it becomes the greater is the temptation to multiply degraded, cheap and nasty movements. Already the bazaar men in the large cities are besieging the manufacturers for their reliable movements, and it requires considerable moral courage to refuse them when they want large orders filled and offer cash in advance for the goods. Thus far the respectable manufacturers have declined to sell to them, but there is danger that they will combine and obtain some cheap movement either at home or abroad and flood the country with it. One of these wealthy merchants recently declared, when he was refused goods, that he would get up a movement of his own and paralyze the local trade. The true policy is to let these outsiders have the cheap and worthless movements and for the legitimate dealers to handle only trustworthy goods, trusting to the good common sense of the public to distinguish between them.

## Outside Competition.

WE HAVE had much to say in THE CIRCULAR relative to the growing outside competition that regular retail dealers are forced to meet. We have recommended dealers to diversify their stocks—to keep stationery, musical instruments, fancy goods, etc.,—and wherever this has been fairly tried it has been found to work to the advantage of the dealer, in some instances forcing the outsider to abandon his lines of jewelry. The dealers claim that manufacturers must not sell to outsiders, but they will not support those who attempt to deal exclusively with the trade; they will buy just as quickly from a manufacturer or jobber who circulates price lists and catalogues promiscuously and who sells to outsiders, as they will of those who confine their transactions within the trade. What encouragement have manufacturers to reject this outside trade when it is offered to them? It is their business to make goods and sell them quickly, and the outside buyer is generally prepared to purchase liberally and to pay cash for what he buys. We know of certain manufacturers who have persistently refused to sell to outsiders, while knowing that their competitors were selling to whoever would buy. Did the dealers recognize this effort to protect their interests? Not a bit of it; they bought just as liberally of the other manufacturers as ever, knowing that they were selling to outsiders. The same is true in every other branch of the jewelry business, and manufacturers are beginning to feel that in this respect virtue is *not* properly rewarded. It is largely through the laxity of the retail dealers in their transactions with manufacturers and jobbers that has opened the way for outsiders to obtain a foothold that cannot be easily broken. Unless something is done, however, it will be but a short time before watches of all grades and jewelry of all kinds will be as readily found in the fancy bazaars as in the stores of legitimate dealers, and all that will be left of the exclusive trade of the latter will be the repairing, requiring skilled labor, which the outsider may eventually be prepared to furnish as well.

But there is a way to prevent outsiders from cutting into the jewelry business, and that is for the local dealers to combine together to fight with fire the person who seeks to steal away their trade. State associations at one time promised to remedy this evil, but as their management fell into the hands of self-seeking individuals, the efforts in this direction proved abortive. The state associations were a delusion and a snare, promising everything and accomplishing nothing. It is possible, however, for the retail jewelry trade to take a hint from the fire underwriters who have local boards in almost every town for the government of the business in that locality. If an outsider attempts to carry a stock of jewelry, let the regular dealers come together and each agree to make a specialty of some particular thing the outsider carries, and cut the price so as to take away his custom. This would soon compel him to desist from encroaching upon their line of trade. How this plan works was recently illustrated in a neighboring city. The proprietor of one of these great bazaars went to a manufacturer of watch movements and offered to take \$100,000 worth of his goods and give his check in advance for them if he would let him have them. The offer was declined, whereupon the bazaar man threatened to get some other movement and so push the first out of the market. The gentleman to whom the offer was made called a meeting of the local dealers and informed them of the bazaar man's tactics. They at once agreed among themselves to make war upon his stock the moment he offered a watch movement for sale, and so notified him. Rather than meet the competition which a dozen determined men would have forced upon him, the outsider wisely determined not to interfere with the watch trade of that city. These tactics can be followed in any city or village; all that is necessary is for the local dealers to unite in the carrying out of the plan and the outsider will be glad to let their trade alone. It is useless for them to look for any help from state associations; their importance has heretofore been conspicuously illustrated; they must depend upon themselves not only to prevent outside competition, but to improve the public taste in the choice of goods.

IT IS unquestionably true that trade has not been especially active during the past few weeks, and there is some discouragement in consequence. But there have been good and valid reasons for a dull period; first, the weather has been most unpropitious in all sections of the country, rain, cyclones and tornadoes working great destruction of life and property in various localities. The floods in the western rivers devastated vast regions, destroying or seriously injuring cities and villages, inundating farms and destroying millions of dollars of values and many lives. These events caused a general suspension of business in many parts of the west and south, local dealers having no purchasers for anything but the absolute necessities of life; when appeals for help for the distressed were going up from those places that had suffered disaster, few persons thought of buying jewelry or any other luxuries. As a consequence, local dealers have had little occasion to order goods; their stocks were full from last fall's orders, and they had no occasion to replenish. In fact, many of them were overstocked last fall through the pertinacity of a class of travelers who have no compunctions in overloading a dealer so they get rid of their goods. In the south this is especially the case, and dealers are positively refusing to buy more goods till they dispose of what they have on hand. There seemed to be a prevalent idea in the trade that the south was to be a bonanza for travelers to work this spring, and, as a consequence, these missionaries overrun these States in full force. But the result has not fulfilled their anticipations, for the reason that the dealers had about all the goods they wanted and could not be persuaded to overstock themselves just to oblige the travelers. How long this dullness is to continue no one can tell; the probabilities are that it will not be of long duration, but that a fair demand for goods will set in that will compensate for the dullness of the past few weeks. There is not going to be any "boom" in the business this year, but we predict that the aggregate sales will compare favorable with last year. But we warn the trade against overproduction and against overstocking dealers; these are the two greatest evils the trade has to contend with, and when indulged they are sure to react disastrously. Let the production follow the demand, and sales depend upon the conditions of the market; if the dealers can sell the goods let them have them, but do not load them down with goods they have no demand for. Conservatism in business is now demanded of all classes, and especially of the jewelry trade.

---

[Copyright Secured.]

### The Cup—Its Art and Customs.

[BY JOHN W. MILES.]

*Continued from page 73.*

FRANCE followed closely after Italy in the art of the renaissance. The visit of Cellini, who established many goldsmith's shops in Paris, had given the artists of that city some of the inspiration of his own pure genius. Francis I. was on the throne of France. A *litterateur* in the highest sense, and fond of magnificent display, arts and learning received from him the greatest encouragement. The regal pomp and splendor that attended his interview with Henry VIII. of England at "the Field of the Cloth of Gold," and the magnificence of his famous palace at Fontainebleu, demanded from the artists of his time the greatest efforts. The luxurious habits and taste that characterized the epoch found expression not only in costly materials but also in the most exquisite workmanship, the plate of the nobility, particularly, demanding the highest skill. Examples of the French work of the period are rare. The famous "Nautilus Cup," figure 41, in the possession of Queen Victoria, is so nearly in Cellini's style as to be attributed to him. If not of his design it is probably French work. It is formed of a large shell having the form of a ship and supported upon Neptune, who is himself mounted upon a sea horse. The cover represents Jupiter posing upon an eagle and grasping the

thunderbolts. The foot of the cup is in the form of the upper shell of a tortoise, and supported by sirens singing to the accompaniment of musical instruments. Other sirens border the cover, and four figures of females posing in carratides relieve the mounting of the shell. The mounting is of silver with some parts of gold, notably the armour and clothing of Jupiter and also the marine horse.



*Nautilus Cup, Silver and Gold, Figure 41.*

Among the prominent goldsmiths of the time was François Briot, who evinced great skill in embossing tankards, cups and various kinds of plate. His reputation, however, rests principally upon his work in pewter, upon which he bestowed as much talent in design and finish as upon articles in the precious metals. Figure 42 exhibits a pewter tankard made by him that is superior in many respects to a great number belonging to the period that are more highly prized and of more intrinsic value. This placing within the reach of the poorer classes utensils of artistic value is the best possible proof of

the wisdom of the artist, as well as of the existence of a popular appreciation of art that demanded these things. "Art is now made by a few for a few, therefore it is sick and will die unless it turns to the true source of health and life. If it is to live and flourish, to be a part of the life of the days we live in, and not a puny sham of the once mighty hope of time gone past, it must be made by the people and for the people, as a joy to the maker and the user. \* \* \* \* Absolute perfection in art is a vain hope. The time will never come when the hand of man can thoroughly express the best of the thoughts of man. It is enough for a work of art if it shows instinct for beauty, skill of hand, and some touch of human thought and emotions." \*



*Pewter Cup of François Briot, Figure 42.*

Specimens of German art are more numerous, especially those of Augsburg and Nuremberg. The artists of the former city caught the spirit of Italian influence more completely and earlier than the latter. Augsburg was the most wealthy manufacturing city of Germany during the 16th century, and many of the merchant princes were lavish in the display of valuable plate. The treasures at the South Kensington Museum include a silver gilt Tazza illustrative of Augsburg work during the period, figure 43. It is thoroughly Italian. The bowl is filled with *repoussé* decoration of masks, strapwork and



*Silver Gilt Cup, (Augsburg), Figure 43.*

figures in medallions. The central figure represents Charity, while those in medallions surrounding it are symbolic of the theological and cardinal virtues. The stem, knop and base are made to match.

But the goldsmiths' guild of Nuremberg could boast of Wenzel Jamitzer, who was the Cellini of Germany, and whose designs have

\* William Morris.

been, in some instances, erroneously attributed to the Italian master. There is no lack of renaissance ideas in the silver cup designed by him and represented in figure 44. The brim is made in six cusps, and corresponding lobes are beaten out below them, richly chased in *repoussé* strapwork and arabesques. The upper lobes bear three female figures: Diana holding a bow, Lucretia stabbing herself, and Judith holding both a sword and the head of Holofernes. Three vases intervene. The upper lobes, expanding again below their points under the cup, form lesser lobes embossed with three fishes, a lizard, a frog, a prawn, a dolphin and a snail. The upper portion of the six lower lobes bear, in cartouches, three demi-figures winged, armed and crowned, and three arabesque ornaments, while the lower portions of the same lobes contain masks, a woman, Mars, a cherub



German Cup attributed to Jamitzer, Figure 44.

and three monsters. The knop is formed of three rams' heads, and the base, trefoiled-shaped, has three bosses ornamented with *repoussé* mask and leaf work. The extreme upper and lower portions of the cup are believed to be unfinished. The British Museum is in possession of a similar cup, which was for a long time attributed to Cellini, but is now acknowledged to be of Nuremberg work and possibly by Jamitzer. The superior part of this latter cup in *repoussé* silver is divided into six lobes, upon which is represented, in bas-relief, subjects from the Metamorphoses of Ovid, Daedalus and Icarus, Arachue, Apollo and Marsyas, etc. The six other lobes forming the bottom of the bowl exhibit little boys, representing vices and virtues, with Latin legends. A boy with a mirror and a peacock, *sui amans perdit et seipsum*. A boy holding a triangle, *medium memor esto tenere*. A boy on a winged orb, with a crown and scepter, *non*

*sors natura negavit*. A boy with a lyre and a crown of leaves, *tandem bona causa triumphat*. A boy holds a crown of leaves, *virtus sine fine virescit*. A boy holds a cup, *brevis et damnosa voluptas*. The trefoiled-foot bears upon bosses a stag beetle, snake and lizard. The knop is formed of three rams' heads. At the sale of the Hamilton Palace Collection, June 27th, 1882, there was included a German silver gilt standing cup and cover of nearly the same style dating 1580. The center of the bowl is cylindrical, with six cusps at the top and six bosses below, all ornamented with medals of classical subjects, gods and goddesses of most minute and elaborate work. The cover, surmounted by a statuette of Jupiter with his eagle, has also six bosses, whereon is represented an ostrich, eagle and other birds. The border bears a fox, hare and hounds. The knop is formed of rams' heads and flowers, and the foot admirably ornamented with a border of animals. It is 11 $\frac{3}{8}$  inches high. At the sale this piece alone brought £3,244 (\$15,660).

(To be Continued.)

## Practical Treatise on the Adjustment of a Four-Jewel Cylinder Watch.

[First-Prize Essay by HERMANN HORMANN.]

Continued from page 79.

174. Utterly objectionable in all cases is to grind out a hole or a sink with rouge, or, worse yet, with oilstone, and to polish it. Atoms of these agents will often remain, attack the pivot and effect that the oil is retained badly. (Compare Art. 169).

175. If a wheel runs a little out of round, or if a depthing has been corrected by a slight stretching of the corresponding wheel, the stretching of wheels is permissible with inferior and cheap watches, and when rapidly adjusting, because much time is saved by the process. The stretching machine is, perhaps, the best that can be employed for the purpose; attention, however, must be paid to the preservation of their polish.

176. Stretching will always produce inequalities in the wheel, however, which are intensified by rounding with the rounding engine. The Ingold fraises are, therefore, indispensable for the correction of the wheel teeth. Should the polish have suffered in the stretching of a wheel, the sword-file will be found useful for polishing again. Generally speaking, wheel stretching cannot be recommended, but is to be resorted to as last shift only.

177. Since the wheel is intended to be flat and should it run untrue, it is only a consequence of careless riveting; the error must be corrected by being set true, which, however, cannot be at once done at the arms. The pinion with its facet is set upon a brass riveting tool, a hollow punch is taken which passes over the pinion arbor with a fair amount of shake, and, when riveting, the punch is held obliquely toward the side which, by testing in the double callipers, has shown itself to stand back. Should this not prove to be effective in setting the wheel true, recourse must finally be had to the last remedy, by correcting at the arms.

178. Unduly thick wheels must be filed thinner, and especially the fourth wheel must be rather light and well poised. Remove any burr on the wheels by grinding. This is best done by laying a clean linen rag on a cork fastened in the vise, in order to save the polish or gilding; then take a soft waterstone, saturated with oil, and grind the wheel from below (see Art. 169). So as to be sure, pass a soft brass scratch brush through the teeth, after having ground the wheels.

## CHAPTER XV.

### THE ESCAPEMENT.

179. After having reduced the moving power and the train into order, take in hand the most important and chief part of the watch—its escapement.

It would lead us too far were we to engage in the present pam-

phlet, whose duty simply is to explain practical workings and methods for the adjustment of a new watch, to describe the theories and fundamental principles of an escapement; it is presumed that every adjuster or repairer of a watch is passably well acquainted with the functions of its parts; his chief duty is simply to arrange them in such an order that the watch renders good services, and can be relied on as a measurer of time for the ordinary business of life.

180. Many watchmakers investigate the escapement by only placing in the fourth wheel to the cylinder scape wheel and the cylinder; in order to obtain a good performance of the escapement, however, it is well to also place in both the third and the center wheel.

181. After having corrected the various errors discovered in the preliminary investigation at the time of taking down the watch, such as scraping of the balance, steadiness of performance, passage, banking, etc., we next investigate whether the pivot ends of the cylinder protrude through the jewel holes and run against the caps. Should the pivot be too short it is drawn out.

182. For drawing out the cylinder pivot use a pivot polishing file which has a bevel with a fine cut upon the right side. Place the pivot to be drawn out in a suitable bearing of the pivot polishing tool and polish it, while exerting the greatest part of the pressure toward the end of the shoulder, where the bevel provided with a cut files upon the shoulder and stretches the pivot in this manner. If the set lower cap-jewel sits very deep in the brass plate, file away a little from the latter, without, however, damaging the setting of the cap jewel. If the jewel was only cemented in, replace it by a larger or a higher one, or turn a setting.

If the jewel holes are bad, rough, too wide or too thick, replace them now, because a later correcting would entail another examination and correction of the escapement.

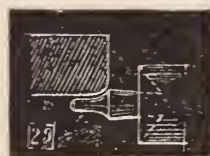

183. Place the cylinder in the plate and examine first whether the mark upon the balance stands upon its correct place, which falls together exactly with the point opposite the balance spring stud, when the escapement with the balance spring is at rest.

184. The banking is examined next, that is, the operator examines to see whether the banking pin in the balance is drilled in the right place. To observe this well, push the point of the regulator precisely to the place where the banking post is drilled in the bridge.



Exactly opposite this place, therefore, where the short piece of the regulator points to (perhaps even a little more to the right), must be located the banking pin in the balance. When the banking pin applies itself against the stud, there must still be a small space between the tooth bearer and the bottom of the small notch (see fig. 30). The banking

must take place only against the stud.

185. The movement is next raised high up in the left hand, and inspected by looking into it from behind on the right side of the bridge; the balance is pushed forward with a pointed pegwood, and attention is paid to whether the cylinder scape wheel passes in the center of the notch.

186. Next, the balance is inspected, by placing a small piece of paper under it, the former is passed along slowly, so that each tooth of the scape wheel falls upon the outer as well as the inner repose. If all the proportions are correct, the cylinder escapement must have formed 5 to 6 degrees repose, the tooth then passes through the middle of the cylinder and a total lifting of 40 degrees is produced. The lifting in our ordinary watches of the present day, however, is ascertained only with difficulty; it varies in nearly every watch, for the reason that the correct proportions have not always been observed. Investigation is, therefore, principally confined to the balance, and to see and contrive the performance in such a manner that the shortest tooth finds a scant, but a secure repose in the interior of the scape wheel.

187. At the same time inspect the drop; that is, whether the scape tooth has too much or too little shake in the cylinder, or whether the reverse is the case when the cylinder stands between two teeth of the scape wheel. A cylinder is too large if the tooth has plenty of shake within the cylinder, but too little between the tooth spaces. It is too small when proportions are reversed. A cylinder with too thick a shell, so that the tooth will pinch within it, should be replaced by a new one with a thinner shell, when doing a passably good job.

188. For investigating the drop, the balance is also pushed forward and the tooth is left to drop upon repose; the balance is next passed back a little and inspected whether the tooth has the necessary shake. This testing must take place with all the teeth of the scape wheel in the inspecting of the balance as well as for the drop, and it is well to count them so that no tooth is forgotten. We would, therefore, have 30 drops when investigating it. At the places where we find very little or no shake at all, small marks with rouge or oilstone dirt are made with the point of a pegwood, so that any incorrect teeth can be equalized at some future time.

189. If the passage in the cylinder was satisfactory otherwise, but that the scape wheel ran a little out of true to one side (Art. 177), it is straightened upon a small brass anvil kept for the purpose, by means of small taps upon the arms close to the eye, to the side where wanted.

If the cylinder wheel moves a little too high in the notch, also the cylinder must be raised a little; this is done by turning out the plate for the lower bridge, if the set cap-jewel lies very deep in the brass plate by filing it down to its setting. Recourse may frequently be had if the lower jewel hole is set very far from the cap—that is, if it lies deep within its setting, by turning lower the bottom for the cap-jewel plate.

190. If the escape wheel lies far too low, the lower cylinder bridge must be set somewhat lower (but this is possible only when the arms of the balance move with sufficient room above the scape wheel bridge). This remedy is effected by cutting burr (not by hammering on their sides), or by drilling in pins in the vicinity of the jewel hole at the lower bridge. If there are objections to placing the bridge higher or lower, considered from the dial side, because there is too little place underneath the dial, the files spoken of in Art. 182 are of great utility, since the lower pivot may be shortened optionally, and the correct or necessary length of the pivot, together with a handsome bevel, may, with the files, be made again by drawing out (see Art. 182).

191. If the small notch in the cylinder was too small, it is to be ground broader. For this use, as well as for grinding the small notch deeper, I have always employed a home-made grinding file, which is easily made.

For this purpose split a splinter from a fine Mississippi stone, and upon a round revolvable grindstone supplied with plenty of water, grind it flat upon both sides, and of the thickness of the little notch. Then make a handle of iron or brass as is shown in the figure, and



cement this small stone in a notch in the handle. The Mississippi stone has the advantage that it cuts well, wherefore work with it is expedited far more quickly than with a ruby file or by means of any other grinding process. It is connected with the only disadvantage that a small notch cut with such a file does not receive a handsome flat ground; this little disadvantage, however, is by far overbalanced by the many other preferences.

192. The correct placement of the repose must be effected by the removal of the lower bridge; if there is too much repose by removing from the scape wheel, if we find too little or none at all, then b-

placing closer, by bending the footpins correspondingly with the pliers, or by moving the bridge with a short tap (see Art. 135). If, however, the difference of the necessary displacement amounts to more than can be effected by the bending of the footpins, they are taken off altogether from the bridge, the countersink for the screw head is made larger or the latter made smaller, and the screw holes are filed somewhat longer toward the opposite direction toward which the bridge is to be moved.

The bridge is next screwed on and moved in such a position without mounting the cylinder, that the middle of the scape tooth, as seen from above, passes above the lower cylinder pivot hole. The cylinder is next placed in and the repose is investigated. By a little easing of the screws and displacement of the bridge, the repose may be regulated very precisely. Other footpins are then drilled into the bridge from above through the former holes of the plate.

Should the recess in the plate not permit a displacement of the lower bridge, it is to be enlarged upon the universal lathe (accompanying figure 32 represents this in an excessive manner), or the roundings of the lower balance bridge are additionally filed at the necessary places.

193. The correcting of the drop is done by shortening the scape wheel teeth. Before any grinding is attempted on the teeth, however, examine very carefully whether the cylinder is appropriate in size, otherwise the danger of spoiling a serviceable wheel might easily be incurred, to fit it to a cylinder either too small or too large, generally speaking to an incorrect one. With too small a cylinder the wheel tooth will in its interior touch with its point and heel together the shell of the cylinder; while, when the cylinder is located between two wheel teeth, the latter will have too much shake, and with too large a cylinder the reverse will be the case. In common practice a cylinder rather too large is preferred to one too small.

194. If the cylinder is suited in size to the wheel, the teeth of the latter which were marked with rouge are shortened (see Art. 188). This shortening is done at the points with a very thin ruby or sapphire file, by holding the scape wheel with the thumb and forefinger of the left hand above the pinion, and performing the shortening either by free hand, or placing the tooth upon a piece of pegwood, as support fastened in a vise. The jewel file must be so thin and small that it will not touch the heel of the next tooth; nor must it have scratches or inequalities, whereby the tooth might easily be broken out. The point of the tooth is next ground from within in a direction which would indicate the prolonged line over about 3 or 4 teeth, a little shorter than is shown by accompanying figure.

195. Many watchmakers equalize the scape teeth in such a manner that they measure the intervals with a turning arbor, and compare all the teeth according to a definite number of the hole gauge to obtain them equally long. A hole may also be drilled for this purpose in a thin piece of sheet brass, the former having a diameter corresponding to the length of the shortest tooth.

This method, however, can lay no claim to great precision. It will be advantageous, therefore, after the marked teeth have been shortened somewhat, to again mount the cylinder and to again investigate all the teeth, and, if necessary, to again mark the unduly long ones. When, also, these have been correspondingly shortened by grinding, the points of all the teeth are rounded off with a small rounding-polishing file, and they must afterward no longer scratch upon the thumb nail.

196. As a frightful example of senseless working, I will recount the instance of a workman near me, who, in order to shorten the scape teeth, made use of a square Mississippi stone, which he forced between the wheel teeth, in this manner simultaneously shortening the heel of one tooth and the point of the next following, whereby

he botched the wheel so sadly that it had to be replaced by a new one.

197. If it became necessary in the correcting of the escapement to move the cylinder closer to the wheel, so as to obtain the correct repose of the tooth upon the cylinder, it may happen at times that in consequence of an incorrect proportion of the balance to the scape wheel the banking pin passes too scant to the arbor of the fourth wheel, or butts against its pinion. If this defect cannot be corrected by shortening the banking pin, by turning down the arbor or by drawing out the pinion (the depth of the third wheel, of course, must not suffer thereby and become too shallow), a practical remedy is as follows: Remove the banking stud under the balance bridge, also the banking pin in the balance, and then drill another banking pin upon the opposite side of the former one in the balance, in order to, in this manner, profit by the arbor of the fourth wheel as limit. To be certain of finding the correct spot for the banking pin to be drilled in, the balance is placed in such a position that the repose mark upon it stands opposite to that of the balance spring stud (Art. 183), and the regulator is then pushed with its shorter end (in which the balance spring closing is fastened) precisely toward the arbor of the fourth wheel. The long side of the regulator then indicates the exact place for the pin to be drilled in. It is practical to drill the pin entirely through the rim of the balance, since it obtains a better hold, and to make it of steel not being so apt to gum against the stud when the watch goes for a time.

198. When the shortcomings of the escapement described above, and found more or less in every watch, have been remedied, the cylinder is mounted again, and its performance is tried by again closely investigating notch, repose, drop, banking and end shake, and not remaining content until all errors have been corrected.

199. When the proportions, the shape of the lips as well as the lifting faces are correct, when the cylinder itself and the lifting faces are polished well, no burr adheres to the exit lip of the cylinder or on the heels of the wheel teeth, the adjuster may be satisfied that the escapement, if set into order according to the here described method, is reduced into order and will render good services.

200. After the rate has been set in complete order, the cylinder pivots are polished, if necessary, and their points rounded, whereby the bevel of the pivot shoulder is caused to rotate in an appropriate hole of the hole plate, so as not to ruin the polish of the pivot. The pivot ends are polished as flat as possible, in such a manner, however, that the corners are well taken off, and do not scratch upon the nail (Arts. 154 and 155).

201. The balance is then brushed clean and counter-poised. This is done in the counter-poising tool, by revolving the balance with its pivots upon the edges of the tool. The most trifling inequality becomes at once noticeable by the heavy place sinking downward and the balance assuming an oscillatory motion, according whether the inequality is more or less important. The balance must now be made lighter at the place where it is too heavy, by carefully sinking holes close together on the lower side of the rim with a three-cornered chamferer, or by scratching off a little from the lower part of the interior rim of the balance with a graver.

202. Care must be taken, however, not to take off too much at once, because, without heeding at present that the balance is unnecessarily made lighter thereby, it might result in the disagreeable necessity of mounting another balance spring. If the balance is but very little out of equipoise, and the balance spring does not permit of making the balance lighter, since it would cause another spring to be mounted, recourse may be had to drilling in platinum pins at the light places, and reducing the balance into equipoise in this manner. Of course, the pins must not project. This will, in many cases, obviate the necessity of mounting a new spring.

A sure sign that the balance is thoroughly equipoised is its continuous rolling, if the tool is subjected to small concussions, for instance, rubbing with some object upon a milled screw of the tool.

203. Many practical men use their double callipers for poising a

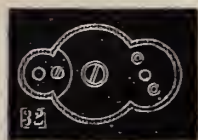

balance, and permit the balance to run with its pivots in the female centers of the calliper. It is necessary with this method, however, first that the holes be polished as highly as possible, and, second, that the pivots be rounded off truly in the middle. If, next, incisions have been made upon one side of the calliper with a sharp cross file, to subject the balance to small concussions. A fairly exact balance, sufficiently counter-poised for ordinary use, will be obtained in this manner; the employment of the equipoising tool, however, will always be preferable for delicate work.

(To be Continued.)

### Aristarchus Plumbago's Bicycle Watch Demagnetizer.

[The following postscript to the letter which we printed last month from our erratic but esteemed correspondent, was received too late to accompany that publication. It somewhat resembles the postscript to a lady's letter, in that it contains the main thing he wanted to say. Although delayed, our readers will doubtless be interested in this annex to his description of his newly invented bicycle watch movement.—Editor THE JEWELERS' CIRCULAR.]

P. S.—In describing the capacity of the bicycle watch movement, I omitted to mention one of its chief qualifications, and will proceed to do so by way of a postscript. The bicycle movement, as previously stated, contains but two wheels, a large one and a small one; these may be placed one in front of the other, parallel one to the other, perpendicular or flat wise according to the space desired to be filled. Being thus destitute of "innards," this watch has but a very slight tendency to become magnetized, and is, therefore, to be commended on that account if no other. But I have gone beyond this and made of the bicycle movement not only a *non*-magnetizer but a perfect demagnetizer, and capable of extracting the magnetism from any other watch or substance, even from the North Pole itself. As I have explained, in that western inebriate asylum in which I was briefly incarcerated through a misapprehension of facts, I met many philosophers and men of genius whom an unappreciative world had deprived of their liberty, as in my own case. From these I obtained many valuable ideas which I shall eventually give practical form and take out patents for. Among the things I thus discovered was the fact that a combination of osocorite and circumvallation properly applied to metal would completely deprive it of all magnetic power, and would also enable the article so treated to demagnetize any other article that is magnetized. So powerful is this substance that magnetism cannot exist near its presence. I have, therefore, prepared the bicycle watch movement with this compound, and made it a perfect demagnetizer. I have heard many complaints of late as to watches becoming magnetized by the appliances used in producing the electric light. Discussing this matter with one of the asylum philosophers, he said he had given much thought to the subject and had arrived at the correct solution of the difficulty. "The tendency of the times," he said, "is to utilize iron and steel in every possible form; a network of railroads envelops the country from ocean to ocean, and from the great lakes to the Gulf of Mexico; in our cities iron takes the place of wood in building construction, while the streets are paved with iron car tracks, and the light of heaven is shut out by elevated railroads and telegraph wires. All this iron becomes highly magnetized by the friction of usage or the action of the elements, and this magnetism is transmitted from these greater to lesser substances even to the human organism, and thus we are virtually walking in a magnetized atmosphere. I have considered this matter," said my friend, "in its relations to human life, and I am satisfied that this electrified or magnetized condition of our surroundings and of ourselves tends greatly to shorten the period of human existence. Owing to this condition our brains are maintained at the limit of their tension. We move, do business, eat, drink and sleep at a greater rate of speed in consequence of the

magnetism or electricity in our systems, and thus crowd the work of a lifetime into a few years." I meditated long over what my philosophical friend said, not that I cared particularly for the human race, but that I might profit pecuniarily by the hint given. After emerging from the asylum, I caused certain experiments to be made in New York city, where more iron work is found to the square mile than anywhere else in the world. Beginning with the elevated railroads, the experts whom I employed soon ascertained that a powerful current of electricity was constantly passing over the rails, the polarization at their surface being north and south at the bottom. All the iron trestle work by which the track is supported, as well as the iron stations, was also magnetized. Every person riding upon these roads is constantly passing through an electrified atmosphere, the electricity being generated in the iron superstructure and transmitted to the person by contact with metallic substances, and is even taken into the system by inhaling the atmosphere. My experts found precisely the same conditions existing in the Brooklyn Bridge, in the surface street car roads, in all the magnificent buildings that line the streets, and even in the streets themselves. This latter fact caused much surprise, but is readily understood when we consider the countless number of iron shod horses and vehicles that pass over them daily, and remember that every impact of these iron surfaces upon the pavement generates friction, and that friction is magnetism or electricity under another name. In one place we found that a sofa placed on a floor beneath which a driving belt was in constant motion, was so charged with electricity that a lady who reclined upon it was literally scalped—the electric current suddenly hoisted her up against the ceiling where she remained suspended and yelling for the police. When she was finally released it was discovered that she was minus her back hair, several switches, bangs, curls and frizzes. This is not the first woman who has gone wrong through a misplaced switch. Subsequently a venerable gentleman lost his wig and false teeth in the same manner.

These ascertained facts led me to the conclusion that an instrument for the demagnetization of all things that are injured by magnetism was something to be desired. Hence the bicycle watch movement, which is capable of extracting that subtle influence from everything animate or inanimate, animal or mineral—where its presence is regarded as injurious. There need be no more magnetized watches, of course—the bicycle watch will eventually supersede all others, but so long as other movements are used, they may be kept free from magnetism by being once placed in contact with a bicycle movement. This, however, is but an incident in the application of this great demagnetizer. It is destined to become the sole and only remedial agent in existence. All the ills that flesh is heir to are the result of too much or too little electricity or magnetism in the system. If one has rheumatism, heart disease, consumption, carbuncles or corns it is the result of imperfect electrical conditions of the body. To remedy this the sufferer has but to purchase a bicycle watch and his cure is inmediate assured. But he must buy the watch himself—a borrowed one will not work the cure; on the contrary, it would be likely to lead to a complication of disorders that would speedily prove fatal.

The bicycle watch movement, in addition to being a benefactor to the human race in the manner I have indicated, will also restore peace and harmony within the trade. As it is to be the watch of the future, superseding all others, it will be furnished to dealers at uniform cost, so that a standard price can be exacted for it from the public, giving a liberal margin of profit to the dealer. It will be as standard as flour or coal with a fixed price to all purchasers. This will do away with all cutting of prices and all unwholesome competition, and, as a consequence, with all envy, hatred and malice. But as a means of first introducing the bicycle movement I shall stir up all the competition and strife possible between dealers so that they will be able to work off the goods they have in stock. I promise every one exclusive privileges, and make each one believe that no other dealer in the town will be able to buy the bicycle move-



ment; but this is the way the thing has been done for years back, so that no one will be surprised when they find that the exclusive privilege business is a myth and that all dealers have the bicycle movements. Then, after supplying the retail dealers, I shall, on the sly, sell to the outside trade so that the public will be able to get these watches from the hardware merchant or furnishing goods dealer as well as from the regular dealer. You see, I understand all the practices of the trade, and will avail myself of every possible means of making a market for the bicycle movements.

As before stated, the stock of this company is now for sale to the trade. Never was such an opportunity offered retail dealers for obtaining control of a watch company that will make watches exclusively for the trade. It is essentially a trade watch company, and it is my ambition to see every dollar of the company's stock owned by dealers. The stock is now ready for delivery, and those desiring it are requested to forward their remittances to me at the rate of \$100 for each share—fifty per cent. discount if the money is received within thirty days.

Yours truly,

ARISTARCHIUS PLUMBAGO.

N. B.—My landlord has just intimated to me that a small payment on account would be acceptable; in fact that if it is not made at once he will drop me out of the fourth story window. As the contemplation of such a contingency is not pleasant, I hereby make the following liberal offer, viz., to wit: whoever will send me \$50 cash within the next ten days shall receive, as consideration therefor, fifty shares of the stock of the bicycle watch company. I trust to receive a prompt response to this offer.

ARISTARCHIUS P.

### Microscopes.

“THIS IS a very fine instrument, but this may suit you better.” Saying this, the optician placed two highly polished microscopes on the glass case for the admiration of an expectant purchaser. One was a monocular, the other a binocular. “The highest grades of binoculars are very near perfection, and, of course, are high priced, while for a small amount you can get a very good monocular. Never looked through one? Then don't, for my sake, attempt to select one off-hand. If you don't know much about microscopes I advise you to read this little book. After deciding upon the amusement you wish to have or the work you desire to perform, you can, after reading this, fix your limit for an instrument.” The young man, after looking through both instruments without seeing anything, took the pamphlet, promising to call again.

“He'll come back,” the optician remarked with a satisfied air. “If he has the microscopic fever on it will be some time before he throws it off. The interest in the use of the microscope both for amusement and scientific or practical purposes increases every year. It was only the other day that the meeting of the Textile Microscopic Association was held in this city. It has more than 100 members, and its object is to increase and encourage the practical application of microscopic work in all branches of the textile industry; to disseminate reliable information pertaining to the requisite instruments and the proper manipulations of the same; to seek and devise means for reducing the cost and increasing the accuracy of microscopic examinations of textile subjects, and to regulate tests by establishing standards. In France, Germany and England the microscope is in constant use in the examination of textile goods, and the uses to which it may be put in the textile industry are almost unlimited. By it a merchant is able to detect the two breeds represented in a sheep that is a cross between a Merino and a Southdown by a fiber of the wool from the animal. He can tell when fiber has been subjected to mechanical or chemical injuries, and can detect adulterations in goods.

“A very common mistake with persons who attempt to select microscopes is to judge of the excellence of one by the amount of

its magnifying power. No object should be viewed with a power greater than is sufficient to clearly show its structure, and if that can be done with twenty diameters, it is folly to apply a hundred. This is especially the case with low-priced instruments, where the actual and angular apertures of the objectives are small, and the corrections not so exact as in those of a higher grade, rendering them more liable to give false impressions of the object. And it is impossible to view an opaque object by reflected light satisfactorily with any of the cheapest forms of compound microscopes. The lenses approach the object too nearly, and are far too small to admit of a proper illumination of the object. For those who wish to dissect flowers, insects, etc., for examination a simple microscope is better. The essential points to be observed in selecting a microscope are that the lenses should give good definition—show objects clearly and well defined—that the stand be of good material and workmanship, that there be no shake or lateral motion in the adjustments of the focus, that the focus be instantly changeable when desired, and that it have a joint for inclination.

“The simplest of all simple microscopes are, of course, the watchmaker's glass, the engraver's glass, the common pocket glass with from one lens to three lenses, the achromatic triplets for the watch guard, and the thread counters. In that class is the collector's pocket microscope like this, consisting of a Stanhope lens in a frame with a glass cover, forming a live box in which the object may be placed. It has a power of about twenty-five diameters, and is useful on collecting excursions. Animalculæ, diatoms, algæ and other objects can readily be examined with it. In the same class are microscopes with glass cages for holding seeds, and the flower microscope with forceps for holding objects. Of microscopes with stands this is the simplest,” taking up a compact little instrument. “With its three lenses combined it has a power of thirty-three diameters, which is sufficient to show many of the larger animalculæ in pond or ditch water, the scales from a butterfly's wing, pollen grains from plants, and thousands of objects. It packs into a box that acts as a base for the upright brass stem. An animalculæ cage, a pair of brass forceps, a watch glass, two plain glass slips, and a prepared object go with it. It sells for \$3.50. This school microscope is nearly similar, but it works easier and is adapted for educational purposes. This dissecting microscope, with a large, firm stage, you probably do not care to look at. Of the compound microscopes this one, selling for \$2.50, is the simplest. It is, as you see, of polished brass, with one eye-piece and one object glass, magnifying, when combined, about forty diameters or 1,600 times.

“Microscopists understand magnifying power in diameters. The power is calculated by squaring the diameter. Here is a powerful instrument with a hinged joint for household use. Its two object glasses magnify from 900 to 10,000 times. Beneath the stage is a concave mirror for the illumination of opaque objects. The prices range from \$5 to \$12. For an amateur a good instrument can be bought for \$23 or \$28, which has a stage with adjustable spring clips, a revolving diaphragm of four apertures beneath the stage, and a concave mirror for use under or above the stage. It can magnify 27,000 times, and, with the addition of a one-fifth object glass, with adapter and cap, 129,000 times. Dr. O. W. Holmes, of Boston, designed a neat little microscope for use by classes. It is very simple, a common lamp furnishing the illumination. A folding microscope of powers ranging from 40 to 140 diameters for tourists can be bought for from \$15 to \$22. For students in histology and vegetable anatomy we have instruments that range in price from \$55 to \$335, and when one of the cheapest is furnished with a condenser, polariscope, camera lucida, stage micrometer, spot lens, zoöphyte trough, live box and forceps, it is complete for almost any investigation. The binoculars have eye-pieces that give 500 diameters or magnify 250,000 times. This binocular,” carefully handling a superb instrument, “was made in England, and I suppose it is the most perfect of all microscopes. It has all the latest improvements in construction, and it has every possible adjustment. The stage

and all the optical arrangements are carried by the limb, which is sufficiently solid to practically abolish vibration. Vibration, by the way, is one of the worst troubles that a microscopist has to overcome. In using the highest powers of a superior instrument the least vibration will prevent satisfactory examination. Some microscopists have their instruments mounted on tables, resting on foundations of stone built up through the house, and not allowed to come in contact with floor or ceiling. That gives you an idea of how fine the adjustment must be. This instrument has a compound goniometer stage, graduated on a silvered ring to  $360^\circ$ , with complete rotary and rectangular movements, and new centering adjustments. The sub-stage, with centering and focussing adjustments, is removable by a lateral slide for illumination by the mirror. The instrument, with two pairs of eye-pieces, the object glasses, condensing lens, stage forceps, and hand pliers, packed in a mahogany case, costs about \$335.

"The accessories are almost as interesting as the instrument itself. The camera lucida consists of a minute  $45^\circ$  prism, through which the reflected image is seen, while the paper and the pencil point are seen around the prism. The compressor is an arrangement for examining any soft or yielding object. The mechanical finger is a delicate apparatus for arranging diatoms and putting them in any desired position. Other accessories are: adapters, achromatic amplifiers, blue glass slips for neutralizing the yellowness of artificial light, condensers for the illumination of opaque objects, eye shades, micrometer gauges, analyzers, polarizers, spectroscope eye-piece, sub-stage condensers and illuminators, life slides for keeping minute organisms alive and in a position for observation, paraboloids and zoöphyte troughs. A syphon slide in which living objects can be kept for observation for days or weeks is an interesting apparatus. Through a chamber containing the minute object a current of water passes continuously, and the processes of respiration, circulation and digestion, and the effects of poisons can be studied.

"A microscopist who is enthusiastic is always interested in the boxes and bottles for collecting objects and the materials for preparing and mounting them. The requisites for preparing objects are forceps, dissecting scissors, knives, needles, turn tables, lamps, glass slips, thin circles, ebonite cells, dropping tubes, Canada balsam, glycerine, asphalt, gold size, white zinc cement, camel's hair brushes, linen cloth, chamois skin and liquor potassa. All objects are mounted dry in air, dry in balsam, or moist in preservative fluid. Dust and moisture are to be always guarded against. A mounting cabinet can be bought for \$20. Cabinets for holding mounted objects cost from \$1 to \$70. The list of prepared objects kept in stock by some opticians is long enough to startle you. About 4,000 objects are named, but I suppose only half that number can be found in any optician's store in this country. The pathological preparations illustrate both healthy and morbid tissues of the human body. There are also blood disks of twenty or more animals, feathers, sections of the whisker of a lion and the eyelash of a whale, parasitic insects, whole insects not parasitic; parts of insects, such as eggs of the butterfly, eyes of beetles, bees, moths and spiders; legs and feet of ants, hornets and spiders; tongues of bees and moths; scales of butterflies arranged to form bouquets and vases of flowers; crustaceans; worms, embryo oysters, sections of coral; foraminifera and polycystina. In the vegetable kingdom are double-stained objects of flowers, fruits and leaves, more than a hundred sections of woody and other stems, besides barks, fibers, petals, pollen, roots, seeds and stones. Then come ferns, mosses, fungi, lichens, algæ diatomaceous earth from twenty-five or more places. From the mineral kingdom are sections of coal, flint, fossil bone, fossil fern, fossil wood, nummulitic limestone, which is the foundation of the Egyptian pyramid; sections of minerals, as agates, gneiss, mica, lapis lazuli, porphyry, quartz, satin spar; syenite and zeolite from the Giant's Causeway; crystals of alum, arsenic, borax, citric acid, copper, gold, mercury, morphine, silver, strychnine, sulphur

and hundreds of other chemicals less known. Speaking of minute things, the microscopic rulings on test plates which measure from 1-5,000 to 1-250,000 of an inch, are about as small things as one can imagine. Last of all, the books on microscopic subjects form a small library, and if I have not given you enough information, I can refer you to books that will make your head swim."

---

### Insurance of Precious Stones.

SINCE THE Hatton Garden post office robbery the offices have been very circumspect in dealing with this department of insurance. Continental post offices hold themselves answerable for the contents of registered letters and packets, provided their value be declared beforehand, and a small sum, in addition to postage, paid to cover risk of loss. But great risks the post office refuse to accept on any terms, and they draw the line at a very modest maximum. This system, which the English Post Office has not yet thought fit to adopt, is a great convenience in a country like Switzerland, where the manufacture of watches and jewelry entails the frequent transmission of gold and precious stones. As a rule the system works well; but when diamonds are in question foreign postal administration and insurance companies are sometimes victimized by persons whose positions might be supposed to offer a sufficient guarantee for their honesty. In April, 1882, a firm at Chaux de Fonds, canton Neufchatel, Switzerland, had certain diamonds, valued at £6,400, to send to Bucharest, and this being beyond the post office maximum for transmission abroad, the insurance was effected with two companies—La Baloise and La Suisse—which cultivate this sort of business. In consideration of an agreed premium the guaranteed safe delivery of the diamonds which were handed to their agents, Mayer, Freund & Co., and sent by them in a registered packet to the consignee at Bucharest, M. Julien Bloch, a relative of the consignors, and their representative for the whole of Roumania. The packet arrived at Bucharest on April 30, and, in accordance with the usage in such matters, was handed by the post office to the custom house authorities, who duly advised M. Bloch of the fact, and asked him to claim his property. Six days later that gentleman called at the custom house and asked for his box, but the box was gone. "It contained diamonds—diamonds worth 100,000 francs," said M. Bloch, "and it must be found." The custom house people were quite of the same opinion. They, too, said the missing diamonds must be found, but they were not found, and M. Bloch went away without his precious box. Naturally enough he did not seem much concerned at his loss; the diamonds, as he remarked to M. Georgesco, chief of the custom house, being insured for almost their full value, and M. Bloch gave himself no further trouble about them, not even informing La Baloise and La Suisse of what had come to pass. But the Bucharest post office authorities were less indifferent. They instituted a minute search for the missing valuables, and a searching investigation into the circumstances attending their disappearance. In the end, whether influenced by fear, or, as he himself said, moved by remorse, a certain Sperlich, a minor revenue officer, confessed that, after handing the box to M. Georgesco, he had stolen it from that gentleman and handed it to M. Bloch, who had promised him for his pains a reward of £200. Sperlich said further that the box contained nothing but sealing-wax, and that Bloch had contrived its disappearance in order to get the £6,400 for which it had been insured by his confederates at Chaux de Fonds. On this Bloch took to flight, but was arrested at the frontier, brought back to Bucharest, tried and condemned to four months' imprisonment, a term which the Court of Appeal subsequently increased to twelve months. Sperlich received the same condemnation, and Georgesco was sentenced to fifteen days' imprisonment for neglect of duty. It will hardly be believed that after this exposure the firm at Chaux de Fonds had the hardihood to sue

La Baloise and La Suisse for £6,400, the amount for which they insured the box of sealing wax. But they did, and the case has been decided by the Tribunal of the Seine—of course against the consignors. The matter was probably referred to the Tribunal of the Seine because, although the companies in question are Swiss companies, their headquarters are at Paris, and they have "elected domicile" there. In other words, if you want to sue them, the action must be tried in the department of the Seine.—*Insurance Post (London)*.

## Problems in the Detached Lever Escapement.

BY DETENT.

BEFORE WE resume the problem of too shallow depth of the ratchet tooth lever escapement, it would be well to consider the normal conditions of such an escapement when in perfect order, or if not in perfect order, in such a condition as to perform well. We will assume it is a watch and commence by removing the hair spring and putting the balance in place, and restoring the cock screw so the watch, if in good order, will run on what is termed half time; *i. e.*, the elasticity of the parts will cause the balance to continue its vibrations. If it will do so, it is safe to consider the watch in good order for keeping time; if it will not perform its functions in this way we will proceed to investigate the difficulties. We will start the examination by turning the balance so the jewel pin is out of the fork; we now move the lever so as to bring the guard pin against the roller (or roller table as some say), and see if the tooth resting on the locking face will leave the locking face and attack the impulse face; if it will do so, one or two defects must exist; either the guard pin is too far away from the roller or the escapement too shallow. This is easily determined if we have studied our model; we know that from bank to bank the lever should have ten degrees of action, and two of these ten should be for lock, so if we can move the outer end of our lever away from one of the banking pins  $\frac{1}{2}$  of the space, it tells us the guard pin is too far from the roller. At fig. 1 is shown the portion of the escapement under consideration, *c* representing the outer end of the lever, and *a b* the banking pins and

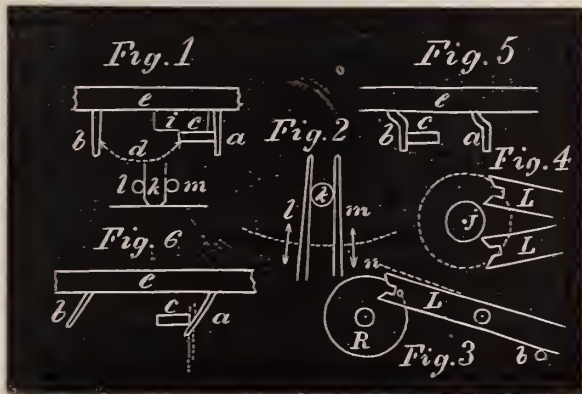

*e* the top plate. We should now remove the balance and see if the guard pin has not been tampered with; if it stands perpendicular and seems all right, let us examine the lever action. Let us cut a small piece of pith (shown at *i*), and put it between the end of the lever *c* and the plate *e*; the object of this is to create a friction sufficient to hold the lever in any position in spite of the action of the scape wheel; we now with some delicate instrument applied to the fork move it back and forth, bending the banking pins so that the instant a tooth leaves the pallet the end of the lever *c* is quite against the banking pin. The moving back and forth of the lever should be repeated until the scape wheel has made a full revolution. Setting or manipulating the banking pins in this way is called *banking up to the drop*. Now remove the pin of pith *i*, and by means of a smooth, round file rested against the pallet staff cause the lever to vibrate back and forth. In fig. 1, *m l* shows the position of the round file, and fig. 2 the direction (the double-headed arrows indicate that the

file is moved back and forth in the direction of the arrows). It will be seen that the file will, in one case, press the pallet staff toward the scape wheel as close as possible; while if applied on the opposite side it will keep the pallets as far away as possible. If the scape wheel revolves freely under this test we may feel pretty safe after one more test. This is to move the lever away from the pin against which it rests if the escapement is correct after the lever has moved one-fifth of the space encompassed by the dotted line *d*, the tooth should be disengaged and the impulse given. Try the wheel around and if this condition exists on each pallet from each tooth the pallet action is all right. If, on the other hand, the teeth are disengaged before at least one-sixth of the space is passed over, the escapement is unsound and is to be remedied as will be subsequently pointed out. Again, if (as is frequently the case), the lever will pass over one-third or one-half the space before the tooth is unlocked, the pallets are incorrect in form and must be manipulated, as will also be considered. We have now (in our supposed case), our pallet action all right, and let us restore the balance and see if the roller and fork action is also right. We put in the balance, and the guard pin on one side binds against the roller so tight that the balance will not turn. Well, what are we to do—open the banking by bending the pin away from the end of the lever? No, no. But still this is just what most workmen would do. But what shall we do? Let us consider the difficulties involved. With one model we could set the balance staff to one side and get the same condition. In the present case we cannot very well move the balance staff with the bridge and potence to one side; we must rather seek to manipulate the lever so as to produce the same results. After applying the above mentioned tests we know the pallet action is correct. Now, we also know the fork is only a medium for conveying the power from the pallets to the balance, consequently we can turn it a little to one side (or in any direction) without losing an atom of its power. The fork and pallets are usually held together by friction on the pallet staff and two steady pins; if now we remove the steady pins we can move the lever as shown at the dotted line *n*, fig. 3, where the full lines show the lever as it stands, and the dotted line the position to which we wish to remove it. We now have the lever comparatively loose (only held in place by its friction on the pallet staff), and we next move it around in the direction of the dotted line so as to get our fork action as it should be. Here again comes into play the knowledge acquired by the study of our model, as arbitrary rules for setting the fork can hardly be given. But we can give positive and definite rules for making a correct escapement; but when we come to such changes and alterations as are now under consideration, good judgment (the judgment established and educated by the study of our model) is our best guide. We now bend our banking pins so the fork will pass equally to each side of the foot hole jewel of the balance staff as shown in fig. 4, where *L L* represents the fork as resting against the banking. Of course, the banking pins are at the opposite end of the lever but they control the lever (fork) so it rests in the position shown. In bending the the banking pins, they should be bent as shown in fig. 5 and not as in fig. 6, as it will be seen that any end shake in the pallet staff would change the banking from one dotted line to another by simply turning the movement over from dial up to dial down. The lever should be shifted on the pallet staff until the fork and roller action is all right, and the pallets and scape wheel are relative to each other precisely as they were when we first adjusted them as above directed. After the parts are all arranged as described the same rules as regards lock and drop must be observed, and the same method of testing the guard pin. If the lever is too short, bending the guard pin forward is not going to materially remedy the difficulty. We must resort to the depthing tool and this will be subsequently discussed. Now for an explanation of the general basing of this problem which we have just considered. *In the case of too shallow depth, if we had moved the pallet staff toward the scape wheel we would have produced precisely the condition of things we have been considering.*

One change necessitating another until we have a train of complicated alterations to effect. Consequently we should make any and all changes with great caution. We should see to the end. We will take up the conditions involved in too shallow depths, and consider them separately and at length, as in a great measure the same principles apply to the club tooth escapement as well.

### Advice to Watchmakers' Apprentices.

BY A MAN WHO HAS SPENT TWENTY YEARS AT THE BENCH.

IT IS not always convenient to obtain pure gold to modify our alloys; consequently gold coin is used which is 900 fine, and as our books and instructions I believe without exception only give the rules for pure or fine gold as it is termed, I will give the rules for compounding alloys of any fineness less than  $\frac{5}{100}$  from standard American gold coin. The rule for calculating the proportions is the one known in the arithmetics as Alligation. There is a feature of the calculations which should be taken into consideration, and that is the absurd usage of 24 karat standard. All our alloys should be on a decimal basis. If we look for a composition of brass or bell metal in any work on metallurgy we find the proportions invariably given in hundredths, and so in the present case, as our coin standard is in 1000ths, let us use the same standard in all gold alloys and call 18-k. gold  $\frac{5}{1000}$  fine. I presume most of my readers are familiar with the rules of alligation; still one would be very excusable for not recollecting them, as in business life, except to jewelers, they are seldom called into use. The method of working the rule is as follows: We will first, however, give the decimal equivalent for the different alloys in 1000ths:

|             |             |
|-------------|-------------|
| 22-k., 916+ | 20-k., 833+ |
| 18-k., 750  | 16-k., 666+ |
| 15-k., 625  | 14-k., 583+ |
| 12-k., 500  | 10-k., 416+ |
| 9 k., 375   | 8-k., 333+  |

The reader need not be told that to convert the karat expression into decimals, he should add cyphers to the karats fine given and divide by 24; as, for instance, what is the decimal of 18-k.? Add 000 which reduces it to thousands and divide by 24;  $18,000 \div 24 = .750$ . The alligation method is worked as follows: Suppose we have some 10-k. scrap we wish to raise to 14-k.; by adding gold coin 900 fine we would work it thus: Write the desired fineness in decimals to the left (14-k. in decimals being 583) thus:

$$583 \begin{cases} 416 = 317 \\ 900 = 167 \end{cases}$$

then to the right put the decimal of 10-k., 416 (see table), and below this put the gold coin decimal of 900. Still farther to the right we write the difference between 583 and 900, not opposite to the 900 but opposite the 416 or 10-k. decimal, while opposite the 900 we write the difference between 583 and 416. Now, the meaning of this is, if we take 317 parts of 10-k. gold and add 167 parts of coin gold, we will have a mixture (alloy) of 14-k. gold. To prove this let us suppose the 317 and 167 represents dwts. of gold, the first of 10-k. fine is worth say 40cts. a dwt., and the second, coin gold worth 86cts., 4 mills a dwt. Now, 317 and 167 added together as 14-k. alloy will make 484 dwts., and this at 56cts. a dwt. (4cts. a karat fine), amounts to \$271.04. To form this 484 dwts. of 14-k. alloy, we used 167 dwts. of coin gold worth 86.4cts a dwt. and 317 dwts. of 10-k. worth 40cts. a dwt. The first amounts to \$144.28 and the latter \$126.80; added together they amount to \$271.08, the 4cts. decrepency arising from the decimals on the 10 and 14-k. as will be seen by taking a series which have perfect decimal expression. Even the slight loss noticed could be reduced to a fraction of a cent by carrying the decimal expression out two figures farther. The truth or accuracy of the rule will be demonstrated by taking such an expression as the fol-

lowing which give perfect decimals, when we will raise some 12-k. to 18-k. stated thus:

$$750 \begin{cases} 500 = 150 \\ 900 = 250 \end{cases}$$

In this case every 150 parts of 12-k. will require 250 parts of coin 900 fine. We will suppose we have 30 dwts. of 12-k. we raise to 18-k.; we make the statement of 150 parts of 12-k. require 250 parts of 900, what will 30 parts require—thus:  $150 : 250 :: 30$  to the required amount. We work it out as follows:  $250 \times 30 = 7,500 \div 150 = 50$ , the required dwts of coin gold 900 fine. Now, to see how this will pan out by values as above where no loss from decimals will occur. We have 80 dwts. of 18-k. from the 30 dwts. of 12-k. and 50 dwts. of coin gold; now, 50 dwts. at 72cts. is \$57.60. And 30 dwts. of 12-k. at 48cts. is \$14.40, and 50 dwts. of coin gold at 86.4cts. is \$43.20, which added to \$14.40 gives us \$57.60, the same result as before. In calculations it is as well to use grains; as, for instance, we had 26 dwts., 14 grains of gold, we would express it thus, 534 grains; it would make no difference with the method of stating the question as in illustration of the last proposition of 30 dwts. only we would say 720 grs.; thus

$$150 : 250 :: 720 : 1,200 \text{ (grs.)}$$

It is almost needless to say 1,200 divided by 24 gives the dwts. In making alloys the general plan of melting has been given in a former article. I shall give a few colored alloys of tolerable simplicity with this advice, that most all colored alloys are difficult to make and work, and for any person not a regular working jeweler they are, with a few exceptions, better left alone.

*Red gold* is 18 parts pure gold, 6 parts copper.

*Yellow gold* is pure gold (24-k.)

*Green gold* is 18 parts pure gold, 6 parts silver.

*White gold* is 12 parts pure gold, 12 parts silver.

*Blue gold* is 18 parts pure gold, 6 parts iron.

This last alloy is difficult to make. Melt the gold under borax and add the iron in bits of fine wire free of rust. Small bits of gold to be flattened can be done without putting through the rolls as shown in fig. 1, where *A* represents the stake, *a* the gold, *s* a piece

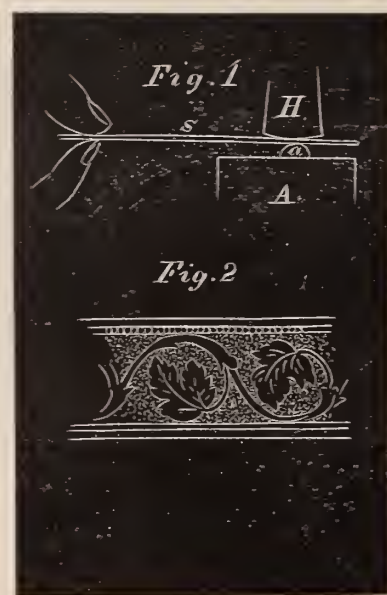

of mainspring (a piece of old music box or French clock), held between the thumb and finger as shown. The idea is to press the gold to the stake and prevent its flying away; the spring being hard and elastic does not buckle much under the hammer *H*. We will give a few brief notes on chasing and engraving, after telling how to get rid of soft solder on such jobs as one has to hard solder. Boil the job in a mixture of crocus and muriatic acid. Take 4 ounces of muriatic acid and add  $\frac{1}{2}$  an ounce of crocus in a bottle; shake the mixture well. Take of this mixture 1 ounce and add 4 ounces of hot water, and keep it hot over a lamp or gas flame; put your article in and in a short time the soft solder will be dissolved off. A com-

mon tea cup will answer. Engraving for chased work is done in several ways. The old style of chased rings was done entirely with punches of various shapes. It is now but little used except to represent articles made 50 or 60 years ago, and to do it well requires a great deal of practice. An easier, and now, more fashionable style is done with both cutting tools and punches; much of this can be done with a drop press, but by far the most artistic is hand work. Of course, the work done by a drop press is produced with steel dies and each is a duplicate of the other. The kind done by hand consists of a high relief somewhat similar to wood engraving while the cut away or depressed portion is matted by peculiar punches. These punches admit of quite a variety of effects both in the grain and in the size or coarseness of the matted ground. At fig. 2 we have a very simple pattern and supposed to represent a portion of a ring. These punches are not difficult to make as will be explained subsequently.

## Lathes and Lathe Work.

BY THE MODEL WATCHMAKER.

IN MY last article I had to leave the description of the face plate and jaws incomplete for the want of space, consequently I shall have to refer in this communication to cuts in former issue, and also to cuts with this number. In fig. 1 of last article in dotted lines at  $r$  was shown an additional step to the jaw  $D$ . Now, it is left to the option of the reader to add this or not; it will not require any larger piece of steel except in height, and it gives the jaws an additional grasp of  $\frac{1}{4}$  of an inch which makes them grasp  $1\frac{1}{4}$  inches. It is true, however, that one seldom in watch work needs to grasp over one inch. In hardening the jaws oil should be used instead of water, and a sufficient quantity should be used to effectually chill and harden the 3 jaws. For such a set of jaws at least a gill of sperm or lard oil should be used. After hardening, the jaws should be reduced slightly in temper by heating them in a portion of the oil used to harden them until the oil emits a dense smoke, and if a lighted match should be applied would flash, but not burn with a steady flame. This temperature of the oil indicates a red purple if the steel was polished, or whitened and heated in the air. The upper face of the slide to the jaws should now be reground on the tool shown in fig. 6 in former issue. After this the back of the flange on the jaw  $D$  (opposite the arrow  $n$ , fig. 1, former article), should be ground in the following manner: An exact counterpart of one of the recesses for the flange on the jaws should be reproduced in a separate piece of brass of about the thickness of the face plate. In fact, a duplicate of the recess shown at  $c$ , fig. 4, last article, so as to receive the flanges precisely as the face plate will eventually receive them. The use of this tool is to grind off the back of the flange true and flat. Such a piece of brass is shown at fig. 1, where  $A$  represents the brass piece and  $E$  the rifler. The face of  $A$  is filed and ground flat, and the recess and slot  $c$  should be produced as formerly directed. The jaw  $D$  is inserted and the back ground off as shown in fig. 2, where  $A$  represents the brass piece and  $G$  the glass slab. Care should be taken to not reduce the face of  $A$  by grinding any more than possible. The jaws should be alternated and ground so as to keep them of the same thickness. The reader will see that by the manner in which the recess in  $A$  is produced, that the surface of the recess is perfectly parallel to the outer surface of  $A$ , consequently the flanges on the jaws  $D$  must be true. After the jaws are all ground in  $A$ , fig. 1, they should be put in the slots in the face plate and ground again on the glass slab, changing them about so they will go into either recess, move easily but without shake. It will be seen by inspecting the cut in my last article, that the recess  $c$ , fig. 4, on the back of the face plate  $A$ , runs from the hole in the center at  $b$  to the extreme outer edge of the face plate, while the slot  $i$ , in which the jaws proper work, only extends from the hole  $b$  to within  $\frac{1}{8}$  of an inch of the outer edge of  $A$ . The

face plate is now ready to be secured to the chuck proper as shown at figs. 2 and 3 of my last article. The shape of this piece and the manner of combining has been described. To the back of the face plate is attached a ring of brass  $n$ , fig. 5,  $\frac{1}{8}$  of an inch thick, measuring in the direction of the radius of the face plate, and  $\frac{1}{4}$  in the direction of the axis of the lathe. This ring or flange serves the double purpose of keeping the outer ends of the jaws in place and also forms the bearings for our ends of the screws which moves the jaws. At fig. 5 is shown a section of one of the jaws, together with chuck, etc., on the axis of the lathe. In this cut all the parts are shown twice the size they should measure. This is done to make the details more distinct. But in the most important parts I will also give the exact measurements. To each jaw is to be added a stud or nut  $a$  in which the screw  $b$  works. I should have added this part before hardening. The making of it is very simple, as it is shaped as shown at  $a^*$ , which is a view seen in the direction of the axis of the screw  $b$ , fig. 5. The brass chuck to which the face plate is screwed is  $\frac{5}{8}$  of an inch in diameter where the face plate is attached; it is recessed for the pinion  $r$  on the screw  $b$ , as shown in fig. 5. This chuck is reduced to  $\frac{1}{2}$  an inch to receive the toothed ring  $c$ . This ring has been described perfectly in former articles except to say the teeth on the edge are on the line  $f$ , and that the outer diameter is  $\frac{6}{10}$  of an inch, and the diameter of the pinion  $r$  is

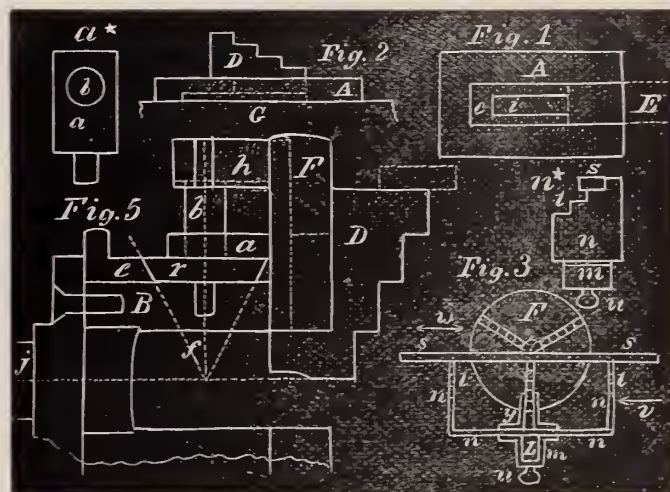

$\frac{3}{10}$  of an inch. The pinion  $r$  is made of steel  $\frac{1}{8}$  thick and hardened. The face line  $f$  is established by where the lines from the axis of the lathe and the axis of the screw  $b$  cross. The screws  $b$  should be accurately made and would be the better if they were cut in a lathe. But if they are carefully turned up before the screw is cut they will work very fairly. I have been led to describe this tool to some length and been very particular in the manner of fitting the parts because I can speak with perfect confidence of its accuracy. There is one point I would call attention to (if the reader uses an American lathe), if the screw  $j$ , fig. 5, which screws into the usual chuck which holds the wax chucks is dispensed with, and a special chuck used so that the screw  $j$  does not have to be run out and in, a degree of accuracy is to be obtained which is next to impossible in any other chuck. Take the above precaution and cut the screws  $b$  in a lathe, and one would be over fastidious who would want anything more accurate. Speaking of lathe cut screws, it is the writer's intention to give shortly a description of a lathe for such work which is cheaply made and in many respects a very desirable adjunct to a watchmaker's kit. Perhaps some of my readers will say of what use is such a lathe to me? I would answer, you can make either right or left hand screw taps worth ten of any plate cut tap; and what is of more importance, make yourself such tools as you cannot buy, as, for instance, a depthing tool which will measure the distance between two pivot holes to  $\frac{1}{1000}$  of an inch and tell you the exact size of wheel and pinion to match, no matter if the wheel is 70 or 60 teeth and the pinion a 10 or 6 leaf. I should have said the steps in the jaws  $D$  are ground to exact  $\frac{1}{8}$  of an inch, *i. e.*, measured on a radial line and  $\frac{1}{8}$  rise. At fig. 3 is shown an arrangement for grind-

ing the steps. The jaws are, of course, supposed to be filed and fitted to very near the correct thing when made; after they are hardened and in the face plate they are ground true as follows: A piece of thick sheet brass (about No. 12), 1 inch wide and (say) 4 inches long is best, as shown at *n*, fig. 3. Diagram *n\** is a view in the direction of the arrow *v*; the steps shown at *t* are to guide a flat piece of metal *s* as shown for grinding the steps; it is moved back and forth in the direction of the double-headed arrow *w*; *m* clamps the lathe bar by the screw *u*. The clamp *y* serves to hold the jaws one at a time until all are ground. It is best to grind one step at a time on each of the 3 jaws, then change to another step and so along until all is done. The pinion *r* has 20 teeth or leaves, and the collar *e* has 60 teeth.

## How to Make and Engrave Silver Bangles.

BY EXPERT.

CUTTING PARALLEL lines with a pentagraph was described in my last article but only from definite patterns. By the addition of a screw and a spacing or dividing wheel we can increase the capability of our pentagraph greatly, and be able to do a great variety of work with it. About the only expense attending this addition is the screw which should be cut in a lathe to insure extreme accuracy. Such a screw should be about 15 inches long and  $\frac{3}{4}$  of an inch in diameter, and have 10 threads to the inch. Any good machinist can turn such a screw, and it should not cost more than \$2 if made of soft steel, which is by far the best material. This screw should have two turned nuts to run on it. A sliding platform is moved by this screw on which are grooved lines either straight or waved. At fig. 1 is shown the general form of the device, *A* repre-

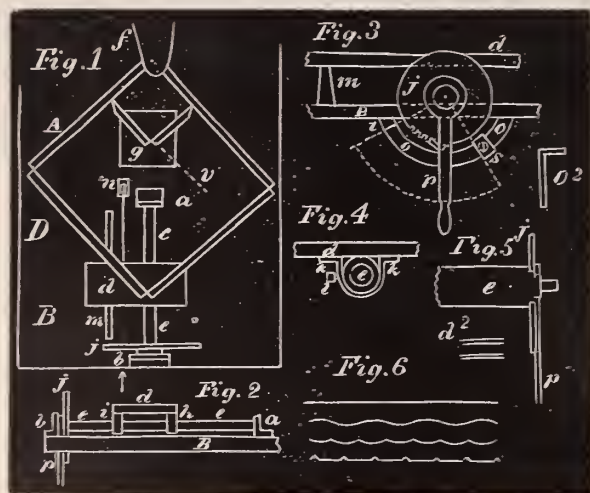

sented the pentagraph, *B* the table on which it is mounted. The pentagraph is the same size as the one already described, but in the present case it is best to make the instrument so the screw goes to the right, and the part at *D* directly in front of the operator. The screw shown at *e* is mounted in two supports shown at *a b*. The parts *f* and *g* are raised a little from the table to allow an opportunity for mounting the screw *e*. The screw *e* is shown separate at fig. 2, where *h i* shows the two nuts running on the screw. The object of using two nuts is to get greater steadiness for the slide *d* without using separate ways. There is some care necessary in attaching these nuts to the piece *d* to prevent them pinching, which will be noticed further along. The slide *d* should be about 4 inches wide and 10 inches long, of some hard firm wood not liable to warp, and on the upper surface is mounted a metal plate in which are engraved lines which serve to guide the copying point of the pentagraph. These lines can be etched in or cut with the graver, and should be deep and wide enough to ensure their holding the tracing point securely—about the  $\frac{1}{10}$  of an inch in width and depth will be found about right. Either thick zinc, such as is used for metallic signs, or

heavy sheet brass answers well for the guide plate on *d*. Care should be used in cutting these guide lines to keep them free of short and irregular crooks and zigzags. If etching is properly used it will produce about the best lines. The nuts *h i* can be secured to *d* by a strap of sheet brass bent as shown in fig. 4. These straps should be of about No. 14 brass and of the same width as the nut; at *k k* are two wood screws for fastening the strap to the piece *d*. One nut can be permanently secured, but the other should be left so that it can be revolved a little so the screw works freely in both nuts when the set screw *l* can be used to fasten the nut. Parallel to the screw *e* is an edge of hard wood or metal *m* on which the bed *d* rests. The piece *d* should be loaded enough on the lower side to ensure its being steady during the time the tracing point is following the lines in *d*. A greater portion of *d* should be to one side of the screw *e* and rest on the piece *m*. If the nuts *h i* are properly set, and the bearing *a b* permit no end shake of the screw *e*, the bed *d* will move steadily; but if any unsteadiness is found to exist, if a hole is cut in the table *B* at *n* and a pulley set so that a small cord, one end of which is attached to *d*, and the other end passing over the pulley at *n*, thence down through the table *B* where a small weight is suspended, it will take up all lost motion of the screw both in the nuts *h i* and the bearings *a b*. On one end of the screw *e* is mounted a wheel *j*; this wheel should be about 2 inches in diameter and should have 60 or 80 teeth. An old clock wheel will answer. The use of this wheel is to enable us to move the bed piece *d* at regular intervals. This is accomplished by the arrangement shown in fig. 3. The essential feature of this arrangement for moving the screw is a lever and pawl or click. This lever turns on the same axis as the screw (in fact, turns on the screw), and by means of the segment *o* can be set so as to advance the screw at regular intervals. The cut at fig. 3 is an elevation of fig. 1 seen in the direction of the arrow near *b* (fig. 1). In this cut *B* represents the table and *o* a nearly semi-circular segment made of sheet brass; this segment should be of a circle swept with a radius of  $1\frac{1}{2}$  or 2 inches, and is secured to the lower side of the table *B* by means of feet formed by bending the ends over as shown at *o<sup>2</sup>*, which is an edge view of *o*. Two small wood screws will attach this to the table. This segment is to be mounted concentric to the screw *e* as shown, and has attached to it two stops, one fixed at *t* and one movable at *s*. It will be seen that by means of these stops that the lever *p* can be oscillated back and forth from one stop to the other as shown at the dotted lines. Now, as one stop is movable, it follows that this arc can be made of any extent (say up to 130 degrees). By means of the click *r* the wheel can be moved forward a given number of teeth. The click can be made to operate in either direction, and is held in place by a slight spring. At fig. 5 is shown an enlarged plan of the end of the screw *e* showing how the wheel *j* and lever *p* are attached. The wheel *j* is held in place by being riveted on a shoulder as shown, while the lever *p* is left loose enough to turn back and forth without disturbing the stability of the screw *e* between the bearings *a b*. The upper surface of *d* is engraved with lines as was mentioned above; a sample of such lines are shown in fig. 6. One straight line or one curved or waved line serves as a guide for producing any number (within the capacity of the machine) of lines of the same kind. To illustrate the capacity of our machine suppose we have a monogram we wish to rule, it is attached to the piece *g*, and we commence by setting the tracing point of the pentagraph in the straight line of our series shown in fig. 6, and turn the screw *e* until the cutting point operating on *g* is in the right position to cut its first line. We now cut our first line (long, short or broken), move our lever *p* so as to make the right space, and cut another line and so on. Sometimes it may be necessary to vibrate the lever back and forth two or three times to get the proper space; as, for instance, we wished to cut two parallel lines close together, then a wider space as shown at *d<sup>2</sup>*, we would set our stop *s* so as to ensure the right spacing; cut our line, move our lever *p* and cut another; now, the next space may be double or triple the space existing between the

two lines already cut, so we make two or three vibrations of the lever before we make a third line, then one again as at first. By having the piece *g*, on which the job to be engraved is fastened, turn on a center, lines oblique to the first cut can be produced as say on the dotted line *v*, fig. 1. Parallel lines from such as are shown in fig. 6 admit of endless variety, and can be used for the face of letters or back grounds; as, for instance, a smooth, full-faced letter on a back ground ruled full across the job. The instrument is convenient to use as one sets opposite to *D*, with the lever *p* and the tracing point working in *d* at the right hand, while the left is left free to manipulate the cutting point. The writer does not intend every 35 cent dime for a bangle is to be put through this machine, but if you can do nice work charge for it.

## The Goldsmith.

[By JOHANNES PRETZLAFF, Dresden.]

*Continued from Page 76.*

### THE WET TEST.

This is to be used for gold and silver simply alloyed with copper or silver or both. With silver-containing gold, that is, therefore, when the gold is largely in excess, the parting is to be done with nitro-muriatic acid; with gold-containing silver, if at least 3 parts silver contain 1 part gold, the process is to be performed by quartation, and with copper-containing silver also by nitric acid. In the first case the gold is to be precipitated with protosulphate of iron (green copperas) dissolved in water, in the second and third case, the silver with table salt. After washing especially the silver precipitate, so as to expel not only the excess of acid but also the salt, it is dried, melted, and each button weighed.

In order to collect the pulverulent gold as well as the silver with greater ease and keep it together, a drop of mercury may be added and shaken with it, after decanting the wash water. The mercury will collect all the gold, and may easily be evaporated again in a spoon held over the flame.

### TOUCHSTONE TEST OF SILVER.

The test of silver is far more difficult; an experienced eye and steady hand are necessary for doing it. By laying bare a spot with the scraper an expert will easily distinguish whether the silver has been alloyed with white metals, such as nickel, cadmium, aluminum, bismuth, zinc, etc., which are generally employed for the purpose, or whether it was alloyed with copper, in which case the fineness is easily ascertained by the use of a test needle upon the touchstone.

### TO DISTINGUISH SILVER FROM SILVERLIKE METALS.

The easiest test that can be employed even by a layman, is by scraping or filing a place of the article rather strongly so as to remove the coating in case it might be silver plated, and then to moisten the spot with nitric acid; if, after wiping it off again, a dirty white ground has formed, it is silver; in the contrary case, no essential alteration of the color has ensued.

### PREPARING THE GOLD AND SILVER.

It is necessary to repeatedly glow-heat when hammering or rolling 14 to 18 karat gold, nor must alloyed gold be hammered on both sides without having been glow-heated meanwhile to prevent it from becoming double and crack; as it has to be hammered in a cold state it is generally annealed in alcohol or beer. When rolling, always roll from the same end. When glow-heating, be careful that it does not come near its fusing point because it loses in density. Do not apply fresh coals.

Pliable silver may be hammered upon both sides after each glow-heating, only the stroke must be a firm and uniform one. It is generally hammered at dark red heat, which, of course, is excluded in rolling.

### SOLDERING GOLD AND SILVER.

*Hard soldering.*—For hard soldering a flux is used; borax, which is ground to a thin cream upon a piece of slate or upturned flowerpot saucer, and applied with a small brush to the place to be soldered, together with the solder. Borax and solder are then carefully dried with the blowpipe and flame, the article is next heated up to the fusing of the solder, and at this moment the operator directs the flame upon the place to be soldered.

Great cleanliness is the chief requirement, and is to be produced either with the scraper or pickling; the choice of a suitable solder is another point of importance; a solder neither too soft nor too hard is to be used, and it must always be proportionate to the gold or silver.

If the solder has not flown well everywhere, it may, with good gold, be corrected by a second soldering; in the case of silver or inferior gold, however, it is necessary to first cleanse the article from the old borax by boiling in the pickle, after which it is entirely removed by the use of the scratch brush and beer or with sand; the place is then wetted again with fresh borax, more solder is applied, and it is then soldered again.

Nitric acid is used for cleansing the articles to be soldered; it is diluted with clean water to such a condition till it merely possesses a sharp taste like vinegar.

On alloyed silver, copper and brass or large articles which are soldered in charcoal fire, the solder will also run, but it unites badly with the article on account of the oxide forming and floats in the borax in a globular shape; straining borax is employed, therefore, which is applied as a powder to the soldering place.

*Strewing borax.*—One part pure potash, 1 part culinary salt,  $\frac{1}{2}$  part borax; or, 1 part culinary salt, 1 part sandiver, 1 part borax.

The borax is puffed up upon a plate above a fire, so that it may be reduced to a powder between the fingers; the salt is calcined in a new crucible, everything well pulverized and mixed.

*Soft soldering.*—By soft or tin soldering the soldering fluid or turpentine or sal ammoniac, constitutes the binder. When the place to be soldered has been cleansed well, the article is heated up to the degree of fusion of the solder. The soldering iron is used only in case that the article under treatment is tinned, since in this case the tin solder is reduced to running with the hot soldering iron, and easily unites with the tin.

*Soldering fluid.*—Sufficient zinc is dissolved in pure muriatic acid until it is completely saturated, after which the solution is filtered through linen. It can also be diluted with water for use.

### SOLDERS.

*Gold solder.*—For 22-karat: 24 parts of 22 karat gold, 2 parts fine silver, 1 part copper.

For 20-karat: 4 parts fine gold, 1 part fine silver, 1 part copper.

For 18-karat: 9 parts 18 karat gold, 2 parts fine silver, 1 part copper.

For 16-karat: 24 parts 16 karat gold, 10 parts fine silver, 8 parts copper.

For 14-karat: 3 parts 14 karat gold, 2 parts fine silver, 1 part copper.

For less than 14-karat: 2 parts fine gold, 9 parts fine silver, 5 parts copper, 1 part spelter; or, 10 parts 14 karat gold, 5 parts fine silver, 1 part spelter.

The rule that 16 parts of the gold to be soldered and 5 parts fine silver are used as solder may generally be observed; or, 16 parts of such gold, 4 parts fine silver and 1 part copper; or, 8 parts such gold and 3 parts hard silver solder.

For 8-karat: 1 part 14 karat gold, 1 part soft silver solder.

Color solder for 14-karat:  $\frac{1}{8}$  parts 14 karat color-gold,  $\frac{1}{16}$  parts fine silver.

*Enameling solder.*—37 parts fine gold, 9 parts fine silver; or, 16 parts 18 karat gold, 3 parts fine silver, 1 part copper.

## SILVER SOLDERS.

*Hard.*—5 to 9 parts fine silver, 3 parts brass.

*Medium.*—7 parts fine silver, 3 parts copper, 2 parts spelter; or, 2 parts fine silver, 1 part brass; or, 2 parts 12-part silver, 1 part brass; or, 32 parts 12-part silver, 3 parts spelter.

*Soft.*—8 parts 12-part silver, 1 part spelter.

*Quick solder.*—4 parts 12-part silver, 1 part spelter.

## TIN SOLDERS.

*Hard.*—1 part pure tin, 1 part pure lead.

*Medium.*—2 parts pure tin, 1 part pure lead.

*Soft.*—5 parts pure tin, 3 parts pure lead.

*Quick solder.*—3 parts pure tin, 5 parts pure lead, 8 parts bismuth; or, 1 part pure tin, 1 part pure lead, 4 parts bismuth.

## SMELTING THE SOLDERS.

When smelting the gold and silver solder, first throw in the brass and next the spelter after the gold or silver has been well fused. When this has been done, it is left for a few seconds in the fire, during which time the crucible is well shaken and then cast, not however, in an open, but a well covered tinned sheet-iron ingot, which must be oiled and warmed.

For alloying, take the brass as fine wire or Dutch metal (spurious gold foil), and the prepared zinc (spelter), which is found in commerce ready prepared for this purpose; when using zinc cuttings we cannot be very certain whether the metal has been purified.

## STONING AND POLISHING GOLD AND SILVER.

When the marks of the file have been obliterated the article is stoned, either done with slate stone and water or with emery paper of graduated fineness. The latter is preferable, even for the reason that the greatest part of the gold can be recovered directly, while it is obtained only with difficulty from the stonings. After the article has finally been gone over with the finest emery paper, it is very carefully brushed over with spirits of hartshorn and soap, the filing-wood is also cleansed with the same care before the article is treated with tripoli, so that no emery or stone is mixed in the latter. This is pulverized well, moistened with sweet oil, and the article is then polished with either the buffstick, grinding thread (of unbleached cotton), or the brush. The finishing polish is finally given with the finger or with the ball of the thumb, which is charged only once with the tripoli, and the article is polished with it until the latter turns black and gold-lustrous upon the finger or ball. The last polish, after the article has been well cleaned again, is given with rouge, whereby the light-red is to be preferred to the brown-red.

Fine gold and silver are generally polished only with the burnishing steel and water, in which a little Venetian soap has been dissolved (polishing water).

Tripoli is a natural product.

*Cleaning agent for polishing gold and silver.*—Lampblack is calcined in order to expel the oil contained therein, and a little of it is rubbed upon a good soft polishing leather. It is an excellent means for cleaning gold or polished silverware.

*Cleaning agent for repairs.*—Washed chalk, moistened with alcohol and a little spirits of hartshorn.

*Cleaning agent for colored gold.*—If the red brown spots often forming on colored gold trinkets cannot be removed by washing with spirits of hartshorn, hot water and soap, brush it off with well washed chalk stirred into a cream with said spirits and a little alcohol; then use a soft brush.

## COLORING GOLD.

A gold article to be colored must not by any means be treated superficially, nor even the smallest detail omitted if the operator wishes to do a good job. The gold to be colored must be at least 14 karat, and the copper of the alloy be at least double the quantity of the silver; if the gold is alloyed below 14 karat, the percentage of copper must be still greater. It is also advisable not to use any old gold trinkets for the gold to be colored; it is best to always alloy freshly the quantity wanted. The solders must always be corres-

ponding to the fineness of the gold, otherwise the soldered places will turn black and corrode. Of the above-mentioned color-gold take  $\frac{1}{8}$  parts and  $\frac{1}{16}$  fine silver. For sensitive articles, a few pellets of silver-solder may be added to the solder.

After the article has been ground with the same painstaking as was recommended for luster-polishing, and by washing with spirits of hartshorn and warm water been cleansed from the contaminations, glow-heat it feebly and uniformly, boil it in a weak nitric acid pickle and repeat this treatment until the boiling bath shows a perfectly uniform color, and then change the nitric acid bath for a sulphuric acid bath. Nor must the article be glow-heated while wet, but it is previously to be dried in sawdust. After it has been glow-heated for the last time it is left black and not touched again with the fingers.

The color consists of 60 parts crushed chemically-pure saltpeter, 30 parts purified culinary salt, and 45 parts pure fuming muriatic acid.

If there are many pieces to be colored, proportion the quantity of the color bath so that the salt weighs a little more than the articles to be colored; nor take the ordinary gray saltpeter in lumps but the delicate, clear and white.

Next take a pot glazed within, place the saltpeter and salt in it, and add sufficient distilled water that the mixture forms a cream, place the pot upon a gentle coal fire, and let the ingredient—saltpeter and salt—come to a violent boil while constantly stirring; then pour in the muriatic acid and let the color boil another half minute while constantly stirring, before the articles enter. The articles to be colored are hung in on a platinum or fine silver wire, and immersed in the bath in such a manner that they do not touch each other; they are then left for 2½ minutes in the frothing, strongly boiling color, withdrawn and rinsed in warm distilled water kept close at hand for the purpose, in which they are then left for 1 or 2 minutes. The color is then diluted a little with this water brought again to a strong ebullition, the articles are suspended in it for another 1 or 2 minutes, quickly withdrawn and rinsed in warm water. The colored articles are then boiled in water and a little spirits of hartshorn, when they are ready for mat brushing.

## MAT BRUSHING THE COLORED GOLD.

A mat brushing machine, to be had at every material house, is employed for this purpose, although any small lathe can be fitted up to answer. The fly wheel drives a very small pulley, whereby the great speed with which the mat brush has to revolve is effected. The arbor of the small wheel ends in a center upon which the mat brush is mounted. This consists of very hard, fine brass wire from their wooden core about 1½ inches long.

Since the colored article is, during the brushing, moistened with dark beer, it is best to locate a vessel from which this fluid can ooze by drops above the brush, while another vessel, for catching the waste, is placed below. While the brush revolves with the greatest possible velocity, the article under treatment is held to it in such a manner that the outermost tips of the brush only touch it.

(To be Continued.)

## Proceedings of the Horological Club.

## A DISTINGUISHED BODY OF WATCH AND CLOCK MAKERS.

One hundred and nineteenth discussion.—Communicated by the Secretary.

[NOTICE.—Correspondents should write all letters intended for the Club separate from any other business matters, and headed "Secretary of the Horological Club." Direct the envelope to D. H. Hopkinson, Esq. Write only on one side of the paper, state the points briefly, mail as early as possible, as it must be received here not later than the eighth day of the month, in order to be discussed and reported in the CIRCULAR for the next month.

The Chairman having sent out notices to all of the members requesting their presence at this meeting, the attendance was unusually large. No one knew precisely what important matter had



occasioned the call, but, of course, no one was so childlike and simple as to confess his ignorance. Each one assumed a wise and self-satisfied air, and gazed benevolently at his fellow members as much as to say that *he* knew all about it, only he didn't choose to tell. The general impression was that some one of the multitude of newly-fledged watch companies had sent in a few baskets of champagne to induce the Club to look favorably upon them and give them a good send-off, and there seemed to be a disposition to investigate the matter (including the champagne), and to start a boom for the new concern, provided it should be justified by the quality of their watches (and champagne, and if there was enough of it). All the dark corners and recesses of the Council Chamber were naturally subjected to careful scrutiny, but, as nothing of a bibulous appearance was discovered there, a shade of anxiety settled down upon the previously beaming countenances. A general look of solemn inquiry was then directed upon the Chairman, which speedily became so intense and concentrated as to startle that official, and cause him to cogitate whether his life insurance policy would be valid in case of a riot.

#### EXCELSIOR VISITS THE CLUB.

Just as the suspense was becoming intolerable the door beside the rostrum opened, and the ever popular editor of *THE CIRCULAR* appeared, escorting the famous author of "Practical Hints." The intention was to have a formal presentation and reception, but this idea was at once frustrated by the members crowding up to greet the fortunate bearer of the title "Excelsior," who was literally overwhelmed with friendly hand-shakes and assurances of welcome and esteem. After the exuberance of the meeting had somewhat subsided, the Chairman succeeded in restoring order, and Messrs. Isochronal, Ruby Pin, Waltham, Clerkenwell and others made remarks expressing in a more formal manner the welcome already informally given.

Mr. Waltham then inquired if Excelsior had seen the recent circular of the American Watch Co. regarding the new Breguet hair-spring introduced by them in their watches, and said that, if agreeable to him, the Club would be glad to hear his views.

Excelsior said, in substance: "I have read the circular referred to. It is really quite a valuable little essay on the art of making good timepieces, and shows that the writer understood the science as well as the art—the theoretical requirements as well as their practical accomplishment. This is something to be glad over in these days, when those who control and direct watch manufacturing establishments often run them merely as manufacturing speculations, and understand no more about what is needed to make a watch which will keep perfect time than the blacksmith who works the bellows in the tool shop or the clerk who makes out the bills. Good business management may secure numbers and cheapness, but only an intelligent horological head can insure quality. In the end quality will win—for the really good watches will benefit the trade, satisfy their wearers and build up a permanent reputation, while the merely cheap ones will naturally gravitate to the dry goods and toy stores, and thence into the pockets of children and fools.

#### THE GREATEST OBSTACLE TO PERFECT TIME KEEPING.

"There is no doubt that the greatest obstacle to perfect time-keeping is, as the circular states, the action of the balance spring in different temperatures. It is not the expansion and contraction of the spring—in length, breadth and thickness—which makes the most trouble, but the change in its elastic force which is really a change in its nature as a spring—independently of its expansion and contraction. This change is much greater than is generally supposed, and is even greater than the circular puts it. But its amount is not so injurious as the fact that it is not the same in different springs or in different parts of the same spring. If we suppose one part of a spring to be compressed and stiffened by bending, while another is bent differently and is weakened, another part is hard and another is soft, we have four different conditions of the metal. In heat and cold these parts are all differently affected, and, although the spring

may be isochronous at the temperature in which it was adjusted, it will be 'out' in any other temperature. It is even possible that the part which is most elastic at one temperature may be the least so at another. This different action of the different parts of the spring causes an irregularity in the action of the spring as a whole, which it is not only impossible to calculate or foresee but equally impossible to compensate for, since the compensation follows a rate of progression which, whatever its ratio may be, is comparatively regular. Obviously, a regular compensation cannot correct an irregular action of the hair spring.

#### EXCELSIOR POINTS OUT THE ROAD TO SUCCESS.

"It follows, therefore, that the next statement of the circular is correct, namely, that the only available remedy is to use a spring which is hard and whose hardness is uniform throughout its entire length. This does not prevent the elasticity of the spring being affected by change of temperature, but it reduces the amount of the change and makes it *regular*, so that it becomes possible to compensate for it. All efforts to produce an irregular action of the balance, simulating the irregular action of the hair spring for the correction of the latter, must, from the nature of the case, be impracticable, more especially since both of these actions are liable to be *changed* at any time by very slight causes, or even by the ordinary course of running. The road to success lies in the direction of eliminating all irregularity, weakness and liability to change from both the balance spring and the balance. With a regular, measurable and controlable action in both of these parts, what then remains is merely a matter of the perfection of the adjustment. A hardened and tempered Breguet hair spring is, therefore, a practical improvement of decided importance, and probably the most important which has been recently introduced. We are not to suppose, of course, that we have reached the end of all improvement in balance springs any more than in anything else, but, certainly, until a new and superior form of spring is made known, or a new and better material than steel is brought out, a uniformly and properly hardened and tempered Breguet spring of steel must stand at the head of the list of balance springs for use in pocket watches of moderate thickness."

#### THEY CANNOT SEE WHY "PRACTICAL HINTS" ARE NOT REPUBLISHED IN BOOK FORM.

Mr. Hopkinson then sent up the following letter just received by him, to be read by the Secretary, saying that it was a sample of those continually coming in, complaining of the delay in republishing "Practical Hints on Watch Repairing."

*D. H. Hopkinson:*

Enclosed find \$3.50, for which please send me Excelsior's "Practical Treatise on the Balance Spring." Do you suppose you will ever publish in book form Excelsior's "Practical Hints on Watch Repairing?" I would not mind giving \$10 for a copy. The whole trade is anxious to obtain it, and I cannot see why it is not published.  
Calvert, Texas. Respectfully,  
H. SMITH.

Mr. Clerkenwell said that he often received similar letters from his out-of-town customers, and he presumed that a great many city dealers had had the same experience.

The Chairman added that the Club was flooded with inquiries as to when "Practical Hints" would be published, why they were not published, etc., etc. For a long time we answered these inquiries from mouth to mouth, until the story became threadbare from telling it over and over—but we had given it up, and for a year or more we have left such letters unanswered, for the simple reason that we did not know and had said so often enough.

The genial editor of *THE CIRCULAR* then took the floor and reviewed the history of the "Practical Hints." He said that from the very first they had been welcomed and approved by the entire trade. They seemed to fill a want generally felt, and to be just what practical men required. They gave complete and trustworthy information on matters not generally understood by the trade, and gave it without any nonsense or reservation, in plain, direct language that any intelligent workman could understand. Previous to them, only

a few short series of articles on horological subjects had ever been written in this country, and to this day there has never been published, in any country, or in any language, a continuous, connected series of articles equal to Excelsior's "Practical Hints on Watch Repairing," which appeared monthly in *THE CIRCULAR* for six or seven years." He said this with pride, for he took great credit to himself for having first discovered Excelsior's remarkable talent for conveying instruction to others, and making even the most abstruse subjects plain, and secured his services under a contract to write for *THE CIRCULAR*. At times, when Excelsior would have withdrawn, on the plea that his time was required for his business, he had insisted on his continuing and had refused to release him until poor health compelled him to stop.

"PRACTICAL TREATISE ON THE BALANCE SPRING."

As a result, these articles and their author are known to every well informed workman throughout this country and in many other countries. The first series of them was republished in book form under the title of "Practical Treatise on the Balance Spring," and the adjustment of watches and chronometers for isochronism, positions, heat and cold and rate. These books are to be found in the hands of workmen everywhere, and are recognized as a standard authority on these subjects. They have been republished (pirated) in England, and also translated into German and republished in Germany, proving that the estimation in which Excelsior is held in this country is shared abroad, and that he takes rank with the standard writers of Europe. Even in the old countries, which are supposed to almost monopolize the theoretical knowledge of horology, there is no work which deals with those subjects in the direct, practical and intelligible way that Excelsior's book does, and it consequently fills a want felt there as well as here for information upon those highest and most difficult branches of watch work. He was informed that at least one eminent European writer had taken the liberty to appropriate portions of Excelsior's work, without either giving credit or even using quotation marks to distinguish them from his own.

SECOND SERIES OF "PRACTICAL HINTS."

The second series of "Practical Hints" embraced exhaustive articles on cleaning, examining, correcting and repairing the four principal kinds of watches in use—the cylinder escapement, duplex, detached lever and spring-detent or chronometer—and closed up with a series of illustrated practical articles on wheels and pinions, gearings, depths, trains, etc., which is simply unequalled anywhere. It was expected, at the time these articles terminated, in 1881, that they would soon be republished in book form, but they had not yet been revised by the author. Not only were inquiries and complaints being received constantly, but orders were sent in accompanied by remittances of \$5 to \$10 to pay for the book. As he could not send the books, he was, of course, compelled to return the remittances. He did not mind being pumped or scolded, but when it came to paying back money, he held that that was more of a strain than human nature could be expected to endure without collapsing. He felt that his health was being undermined by such heavy trials, and he should not be able to bear up much longer.

He then confessed that he had deliberately inveigled Excelsior here for the purpose of forcing a compromise, and he suggested to the Club that, as they now had him securely cornered and surrounded, they should extort some definite promise as to when "Practical Hints" would be revised, under penalty of perpetual confinement in this Council Chamber or until he did promise. He then exhorted the members to pour floods of eloquence and argument over him till he was thoroughly permeated and subdued and so bring him to terms. Several members followed in a similar manner, speaking of the undoubted need for the articles in book form, and that they would certainly have a large sale to watchmakers everywhere. They also expressed a hope that he would again take up the pen for the instruction of the trade.

EXCELSIOR ON REVISING "PRACTICAL HINTS."

Excelsior expressed his gratification at their good opinions, and said he had always endeavored to do his best to deserve them. No one could possibly understand or realize the amount of time, study and labor required to write such articles except by actually trying it. It was quite easy to write an article on some special topic now and then when one felt like it. But it was a very different thing to take up a branch of trade knowledge and treat it fully and in proper sequence, to include everything worth knowing, while excluding the rubbish generally taught and believed, and old methods which had been superseded by better ones—and to tell it in a way that even apprentices could understand. It had been his aim to make the articles exhaustive, trustworthy and valuable, and he was glad to believe that he had succeeded.

He then spoke of the pleasant relations, both business and personal, which had always existed between the editor of *THE CIRCULAR* and himself, and said that he had always found him the kindest and most liberal of publishers. He was glad to see that *THE CIRCULAR* occupied the foremost place as the journal and organ of our trades, here or abroad, and said that it was worthy of it.

As regards revising the "Practical Hints," it had always been his intention and still was to do that. They represented too much time and labor to be allowed to perish in their present fugitive form and be wasted. He thought they were of sufficient value to merit being collected in a permanent form. But before doing so they needed careful revising to correct typographical and other errors, supply some accidental omissions by the type setters, to change some parts which were written hastily under pressure of business, and to remodel others to include recent advances and improvements. All this would require much time—and time was just what he could ill spare. He hoped at present to be able to do this work during the coming summer, when business became dull and allowed him a little respite. Most business men took a summer vacation at that time, but he had never been so fortunate as to enjoy that luxury. Whenever one kind of pressure let up a little there was always something else pressing which *must* be done, so that the only relief he ever got was a *change* of one kind of hard work for another. He would not promise it positively, but it was his intention to spend the hot weather in this work. He would assure all his old friends that he kept the matter in mind, and hoped that they might not have much longer to wait.

As regards writing any more articles, however, that was out of the question. He did not expect to ever be able to take up the work again.

In concluding, he hoped the trade would not overlook the writers who were now contributing technical articles to *THE CIRCULAR* and other journals. They were working faithfully and well, and if properly encouraged and stimulated by generous appreciation, there might yet be many Excelsior's among them. His advice to them was to spare no labor or pains in preparing their matter—to tell it all and tell it well. Good work is never thrown away. He assured them, one and all, that they had and would always have the appreciation and best wishes of Excelsior.

---

American Gems.

BY G. F. KUNZ.

AT THE regular meeting of the New York Academy of Sciences, held March 10, Mr. G. F. Kunz exhibited a number of small doubly terminated crystals of quartz, in which the prism was either entirely obliterated or showing only as a faint line. Some of these crystals were slightly abraded, and to an uneducated observer could easily be mistaken for diamonds from their apparent resemblance to octahedrons, which, by many persons, is supposed to be the only diamond form. The crystals exhibited had been mistaken for diamonds, as have been others occurring in the West.

They were found 1 to 4 mm. in length, and were found in the Bear River country, Idaho. Like occurrences have been observed at other localities, especially in connection with the garnets near Fort Defiance, Arizona, as well as loose in the garnet sand through all the garnet region, and in a trachyte in several parts of Arizona.

Another curious diamond is a red brilliant in the possession of Messrs. Tiffany & Co. that at first glance appears brown, while through it a beautiful dark rose-red light breaks in every direction. Really, therefore, it is a red brilliant, or combination of red and brown, or, more correctly, a red diamond with a brown cloud, the red predominating as the stone is turned or the light strikes it in different directions, which change of color gives the stone its dichroitic effect, although no effect is produced in viewing it by the dichroscope. By artificial light it appears brown, but the entire stone throws out bright red reflections such as are produced by the diamond only. One half of the stone is filled with hundreds of irregular shaped cavities, either empty or filled with a transparent fluid, or, as in nearly all cases, with carbon which, in some instances, is in pieces or so fractured as to admit the light through it. These inclusions appear to affect the color sufficiently to produce the brown appearance. Light seems to be very faintly restored under the crossed Nichols prisms, in addition to that produced by the cutting of the gem. The specific gravity is 3.5696.

The two specimens of corundum sapphire brought in for exhibition were kindly loaned to me by Mr. J. D. Yerrington. They are from near Franklin, Macon Co., N. C. One is a crystal weighing 11.5 grammes, and when viewed from the side is so dark a brown as to appear almost black in color, but when viewed from the end of the crystal is a pearly burnt brown.

The other specimen is cut *en cabachon*, weighs  $3\frac{1}{8}$  kts., and is the most perfect star sapphire that I have as yet seen from any American locality. The mineral is very compact, not showing the hexagonal markings so common in asterias, but a remarkably even color. The star shows only on the upper half of the stone, unless viewed by artificial light, when it shows with great distinctness. It very closely resembles a variety of this mineral from the Hills of Precious Stones in Siam. The latter, although the same in color, is either blue or green when viewed by transmitted light, whereas this is either opaque or a faintly transparent brown on the edges. The specific gravity is 4.0008.

The bronze-colored crystals from Black Horse and Village Green, Delaware Co., Pa., are not compact enough to furnish gems. The bronze color in them has been shown by Dr. Isaac Lea to be caused by minute acicular crystals which sometimes occur in bunches. (Proc. Acad. Nat. Sciences, May, 1876).

## Sight.

WHAT THE OPTICIAN SHOULD KNOW ABOUT OPTICS.

Based upon an extensive hospital experience in Austria, Germany, England and New York. By C. A. BUCKLIN, M. D., New York. Author of Detection and Correction of Visual Imperfections, Cause and Cure of Cross Eyes, Effects of Color on Distance, and Monograph on Astigmatism.

*Continued from page 60.*

OIL CITY, PA., February 20, 1884.

I have been an interested reader of articles on Sight in THE JEWELERS' CIRCULAR, and have already gained considerable information; but I am often puzzled what advice to give in some of the applications for glasses to improve vision. One of the peculiarities latterly brought to my notice is that of double vision. My customer, a young man of about twenty-four, has never wore glasses, is slightly myopic, can read distinctly with No. 40 concave lenses, but in looking intently straight before him the letters appear double, but by turning his head slightly one side they appear all right again. In looking at astigmatic chart perpendicular lines appear. All but horizontal lines show two sets of lines. Looking right straight across the street objects appear the same. Glasses do not materially improve the trouble. The young man claimed this annoyance had

only appeared within a few weeks. Thought rest might relieve the trouble. If you can give me advice in matter you will greatly oblige,

Yours truly,  
WM. TINTHOFF.

The patient has slight pareses of one pair of nerves which govern the muscles which move the eyes. When he looks at an object the retinal image does not fall on corresponding points of the retina.

Glasses will not improve him if the trouble is of recent date. If rest does not cure the trouble it must be a question of medicine or surgery.

The following will illustrate:

Miss C., myopic  $\frac{1}{2}$ , the short distance at which she has always been obliged to observe objects has caused her to converge both eyes very strongly in attempting to bring both lines of vision to bear on the observed object. The muscles have become organically shortened. When she attempts to see objects at a greater distance than six inches she sees double. A man at forty feet appears as two men twenty-five feet from each other.

This condition of affairs has existed for years. I immediately cut the internal muscle on one eye and the two men were only one foot apart. At some future date it will be necessary to cut the other muscle; but with myopic eyes it is necessary to observe great caution in relieving the internal muscles, as the natural tendency of myopic eyes is to wander outward. The comfort and relief which this little operation produced was simply wonderful.

Case 2.—Mr. K. noticed suddenly that he saw two lights where there only should have been one.

This case was pareses of the six pair of nerves, due to syphilis acquired ten years ago. Large doses of sodide of potash, mercurial inunction and electricity have restored the single vision.

SOUTH EASTON.

My mother is blind in both eyes. She can tell the light from a candle in a dark room at fifteen feet. Can see a light mist from it when held above, below to the right and the left. There is a whitish spot in both pupils deep in the eye. Four persons from this place have had their eyes operated upon in Philadelphia and none of them can see, consequently we are afraid to try to do anything. We would like your advice about her eyes.

JOHN CLEMENTS.

She has cataract. I went to Easton on March 21st, etherized the patient thoroughly and removed the cataract without accident. Have since received a letter from Mr. C. saying his mother sees well. On the 19th I will go to Easton and perforate the capsule in which the lens formerly was and her vision will then be perfect. This is done with a very sharp needle and does not even irritate the eye.

OGDENSBURG, N. Y., February 24th, 1884.

DR. BUCKLIN:

Dear Sir:—Page 56, in "Detection and Correction of Visual Imperfections," we find the following, viz.: "A cylindrical glass being the *only* glass with which no harm can be done to the eye," etc. Is this not an error? Will not a *concave* cylindrical injure the eye, and is it not true that a *convex* glass is the *only* one that can't injure the eye, whether it be *cylinder* or *sphere*?

Yours truly,  
J. E. BELL.

The statement made by me is endorsed by Prof. Ludwig Mauthner, of the Imperial University of Vienna. A person will not wear for any length of time cylindrical lenses which do not improve vision. They will cast them aside very soon. A cylindrical glass through which a person can see better can do no harm. Spherical lenses, if convex, injure the eye by reducing its accommodation. Concave lenses which are too strong will increase existing myopia or will favor its development in weak eyes.

BEAVER SPRINGS, PA., March 19th, 1884.

Are there spectacles extant or can you construct a pair for me that magnifies at a distance of about twelve inches a small pica letter to the apparent size of a quarter of an inch ( $\frac{1}{4}$  of an inch). If such a pair can be gotten up adaptedly for a normal or unimpaired eye I will buy a set. Please advise me about this, and also quote the price you demand for such a construction and I will have a pair or two of them. Advise early, obliging,

Yours truly,  
PHARUS ROMIG.

They do not exist, and they would destroy your power of accommodation if you used them. An eye-glass can be constructed which nearly fills your unreasonable requirements. The magnification would be too great to be of any practical use in reading print. The field of vision would be so small that you could not keep your place.

NEVADA, IOWA, February 13th, 1884.

*Dear Sir:*—I have a customer for a pair of glasses whose eyes are astigmatic. What shall I do to fit him? I have no cylindrical trial lenses. He reads fair with a No. 11 peroscopic. I gave you my order for ophthalmoscopic test lenses yesterday. Please let me hear from you and oblige, yours respectfully, WM. HANSELL.

I refer you to Mr. Dollenmayer's correspondence on Astigmatism in JEWELERS' CIRCULAR back numbers, also to February number of CIRCULAR.

In attempting to manufacture so complete an instrument for so low a figure as the ophthalmoscopic test lenses, we have been delayed in overcoming mechanical difficulties which were necessary to overcome, owing to the cheapness of the instrument. Although we are rapidly increasing the facilities for manufacturing, still hundreds of orders are registered which we have not been able to fill. Another week will, however, enable us to meet the requirements of the trade.

### The Jewelers' League.

*President*, GILBERT T. WOGLOM.....Of Woglom & Miller.  
*First Vice-President*, WM. C. KIMBALL.....Of H. F. Barrows & Co.  
*Second Vice-President*, AUG. KURTZBORN.....Of L. Bauman Jewelry Co. St. Louis, Mo.  
*Third Vice-President*, JAMES P. SNOW.....Of G. & S. Owen & Co.  
*Fourth Vice-President*, HENRY HAYES.....Of Wheeler, Parsons & Hayes.  
*Secretary and Treasurer*, WILLIAM L. SEXTON.....Of Sexton & Cole.

#### EXECUTIVE COMMITTEE.

ROBERT A. JOHNSON, *Chairman*.....Of Colby & Johnson.  
 SAMUEL W. SAXTON.....Of Saxton, Smith & Co.  
 CLEMENT B. BISHOP.....Of Carrow, Bishop & Co.  
 JOSEPH B. BOWDEN.....Of J. B. Bowden & Co.  
 GEORGE R. HOWE.....Of Carter, Sloan & Co.  
 CHARLES G. LEWIS.....Of Randel, Baremore & Billings.

THE JEWELERS' CIRCULAR is the *exclusive* official paper of the Jewelers' League, and has been selected for the publication of all matters of interest pertaining thereto. Letters or inquiries pertinent to its business or purposes, and which might interest the trade or inquirers, will herein be answered. Address *Jewelers' League, Box 3,444, P. O., New York*, or the office of THE CIRCULAR.

At the regular meeting of the Executive Committee held on Friday, April 4, 1884, there were present: President Woglom, Vice-Presidents Kimball and Snow, and Messrs. Johnson, Howe, Saxton, Bowden, Bishop, Lewis and Sexton.

Treasurer reported balances on hand \$9,976.30.

Ten (10) changes of beneficiary were granted.

One application was rejected.

Fourteen applications were referred for correction, etc.

The following 61 applicants were admitted to membership:

S. Bendit, H. C. Birch, E. K. Boyd, T. L. Carrow, W. Dattelbaum, J. A. Dodd, I. Goldsmith, H. Froehlick, W. Fuhr, T. Lesperance, L. Lilienthal, J. W. Mager, J. Racine, T. A. Reynolds, C. L. Ross, J. F. E. Rosset, B. D. Traitel, R. H. Trested, Jr., N. Y. City, N. Y.; C. B. Brown, Ithaca, N. Y.; L. W. Neff, Binghamton, N. Y.; C. E. Pelham, Cold Spring, N. Y.; R. J. Cushing, Bangor, Me.; C. G. Norling, Boston, Mass.; W. W. Austin, A. W. Hodgdon, J. F. Ripley, Taunton, Mass.; S. M. Hewett, Putnam, Conn.; G. W. Bennett, Bridgeport, Conn.; J. W. Ball, W. O. Dixon, C. P. Krauss, Newark, N. J.; W. D. Dreher, A. S. S. Fussell, A. A. McCormick, H. C. Rowbotham, J. Stemler, J. L. Stockhauser, Philadelphia, Pa.; W. W. Brillhart, Indiana, Pa; A. M. Bronson, Susquehanna, Pa.; H. A. Perkins, Harrisburg, Pa.; B. F. Pierce, Erie, Pa.; W. W. Rudisill, Altoona, Pa.; H. E. Brown, Baltimore, Md.; A. Hebrank, B. Hebrank, Wheeling, W. Va.; A. C. Dalzell, F. J. Greule, Newport, Ky.; G. H. Graham, Lexington, Ky.; E. A. Broadbent, Gainesville, Ga.; W. Schweigert, Augusta, Ga.; W. F. Williams, Pensacola, Fla.;

H. Vahlman, New Orleans, La.; L. Erman, Cincinnati, Ohio; H. Samuel, Cleveland, Ohio; H. C. Simons, Mt. Vernon, Ohio; E. H. Goodrich, H. Teufel, Chicago, Ill.; F. M. Herron, Indianapolis, Ind.; J. F. Brown, Lansing, Mich.; H. S. McDonald, Charlotte, Mich.; E. B. Dennison, London, Eng.

### Ingenious Wood Carvers.

OVER a west-side doorway is the inviting sign: "Artistic Bric-à-brac." In a small square room, up one flight of stairs, were several tables laden with many curious and interesting productions of German and Swiss artists. "The Swiss peasantry are the greatest wood carvers in the world," the proprietor said. "Carving seems to be as natural to them as eating. They carve out of wood, with wonderful ingenuity, anything from a simple paper knife to an elaborate piece of architecture in miniature. Aside from wood carving and some other mechanical occupations they are not good for anything, being very simple, ignorant people. But they have a genius for carving, and have a natural skill for copying from nature. Their floral pieces are regarded as masterpieces, and serve as models for young sculptors. It is only necessary to furnish them a photographic design of what is wanted. Most dealers who import Swiss carvings do this, although the Swiss peasantry produce number less things themselves without the aid of any suggestions. They carve out of wood almost every kind of fancy article, such as ink-stands, nut crackers, jewelery cases, cuckoo clocks, ladies' work boxes, and a large number of other things too numerous to mention. The tools they use are very simple, the carving being all done by hand. The articles they carve are ingeniously ornamented with leaves and flowers, and some of their designs are extremely odd; they are always artistic. Here is a piece of carving in the shape of a nut cracker. It is a life-like representation of a bear on its haunches. Of course it is made more for ornament than for use, but its artistic merit is worthy of careful study. The Swiss have a knack for turning the most simple article into a real work of art. Take this book rack, for instance." The dealer produced a very simple form of book holder for the library table, having two side pieces on a sliding base. "See how artistically the side pieces are carved, showing in bold relief a double rose surrounded with a mass of leaves and vines.

"One advantage the Swiss have is the wood which they use. This is remarkably fine and free from knots, and a tool cuts it as easily across as with the grain. The kind mostly used is known to the trade as peach wood, which it closely resembles in every respect. Another kind of wood which is largely used is called satin wood. This has a pure white color, and, like the other variety, is entirely free from knots, and peculiarly even in respect to hardness.

"The skill of the Swiss in carving wood first attracted notice about fifty years ago. It was not, however, until years afterward that it was turned to account in a commercial point of view, and even then the sales of Swiss carvings were restricted to tourists in the summer season, who made their purchases through the intermediary of hotel porters. Hence the trade was for a long time very small and unremunerative. But in course of time local capitalists took the matter in hand, opened workshops and began an export trade. The business of wood carving now finds employment for several hundred persons. In fact, in one establishment three hundred persons of both sexes are regularly employed. The women have great delicacy of touch, and their work in certain branches is preferred to that of men. Each artisan employed in the workshops has his or her specialty, the choice of which is left to individual taste. Some have an aptitude for and excel in the modeling of groups of animals; others prefer to carve various fancy articles with floral patterns, and some build miniature chalets. The latter is one of the most popular articles of Swiss handiwork. As usually made it is composed of different colored woods. The thatches, with the stones and ropes

to hold them on, and the deep roof, are prominent features. The lower story shows a stable, while the upper stories are made to indicate the family dwelling. The surroundings, including the fence, court yard, pump, and spring, are also given. The roof is so constructed that it can be raised like a lid, and the part which represents the upper stories is lined with plush and is intended as the receptacle for jewels. A movable partition divides this also from the first story, which contains a music box, which is set going by lifting the top cover. The prices of these articles range from \$10 to \$35.

"Few dealers make a specialty of Swiss carvings, for the reason that the production is very limited, owing to inability to turn out the goods fast enough by hand. Besides, all the rare bits of carving are made by the peasants at their homes in the Alps, who work only during the winter season. In the summer they are occupied in tilling the soil and tending their herds of goats on the hill-sides, a pursuit which they love so much that no amount of money could entice them from it."

### The Oldest Clock of Nuremberg.

OUR COLUMNS announced at the proper time that the German watch and clock makers had established a "German National Horological Museum" at Nuremberg, for the collection of the many antique specimens of horology found throughout the Empire of Germany. We see by our German exchanges that the visitor can at every step behold something of interest, and that the student has a great store of the rarest material before him to trace the earliest times, when the art of horology was yet in its cradle, down to its manhood, anno 1884,—from the Folliot escapement with its bar and two weights in lieu of a balance spring to the highly finished chronometer escapement.

Watches, wall, mantle, case, stairway and all other kinds of clocks, constructed of wood, iron, bone, ivory, brass, glass, rock crystal, etc., of all conceivable and inconceivable shapes, patterns and styles of execution; alarm clocks, astronomical clocks, etc., frequently of admirable construction and charged with the strangest of functions, to suit the whim of the first possessor, may be found in this horological cemetery, embalmed, and peering with their sad, lack-luster eyes through the glass cases in which they are kept, as if anxiously awaiting some one to charitably remove them from an age which knows them not. This clock indicated with its one hand the hour when the princely babe was born who was destined to become a ruler; it next admonished the courtiers that the time for the coronation ceremony was approaching, and its next sad function was to measure the dying king's few and weary minutes that lay between his present painful life and unexplored futurity; or that clock which stood within the inquisitorial halls and heard the heartrending shriek of the tortured wretch and witnessed his agonies; or that clock that assisted some Tycho, Brahe or Kepler to discover the grand, fundamental laws by which the universe is governed; or that clock that merrily ticked in sweet lady's bower, and indicated the time when the expected lover should draw nigh for the stolen interview; or that clock that ticked in the humble peasant's hovel, and shared its miseries and breathed its air charged with malaria, poison and death—all, all are collected here into one incongruous democratic whole, divided in life, united in death, seized with but the one thought that they have outlived their time of usefulness and sadly await the time when the fiat shall consign them to oblivion. "Travelers make strange bed-fellows."

Another almost prizeless donation was made to the collection by the Court watchmaker, Gustav Speckhart. We append his interesting report. He says: I found said clock in a lot of old iron which was presented through me to the National Museum.

The clock is doubtlessly one of the oldest wheel-clocks, and manu-

factured about the years from 1400 to 1420, and is therefore the first and oldest clock of the city of Nuremberg. It was originally located upon the clock-tower of the St. Sebaldus Church, and indicated the elapsing hours to the watchmen, who thereupon announced them to the inhabitants by striking the bell in the tower with a ponderous hammer. This hammer weighed 120 pounds and was introduced at the same time with the great bell *Benedicta*, in the year 1392. To prove the age of the clock, I offer the following.

[We omit the documentary proof, being of a local character, although highly interesting, and pass to the descriptive part]:

The clock is entirely constructed of iron and is  $15\frac{3}{4}$  inches high. The dial has a diameter of 11 inches, and is also of iron; the numbers are painted on with oil paint. When I received the piece, the dial was fairly well preserved and divided into 12 hours; this painting clearly belonged to a later time, because the division was not by any means in keeping with the age of the work. After I had carefully peeled off the oil paint, I found a second dial, painted red, white and blue, of a greater age, but also divided into 12 hours. This dial could not, therefore, be the original one, since the division of the day into twice 12 hours did not yet exist; besides this, the hours were, in Nuremberg, counted from sunrise to sunset. That the clock movement was calculated according to the latter division could be seen from the fact that on the outer circumference of the dial 16 nails with round heads are located, the upper one of which, corresponding to figure XII, is sharpened to a point. The 16 nails signify the 16 hours—since the longest day, as well as the longest night, has 16 hours—and were introduced for the purpose of enabling the watchman in the night, without a light, to announce the elapsed hours to the inhabitants of the city. The watchman first sought the nail with the point, then felt downwards, counting the others until he arrived at the nail above which was to be found the point of the hand, and he was able in this manner to strike the right hour.

Understanding the purpose of the 16 nail heads, I went to work to also peel off the color of the second application, and was so happy as to reach the oldest painting, 16 Roman figures in Gothic form, and I had the pleasure of seeing one of the rare clocks, by which the day was divided from sunrise to sunset. When the day was divided into twice 12 hours, about 1560 to 1580, the old hour wheel was removed and replaced by a new one, which is still contained in the movement. The dial was also at that time numbered to correspond. The clock has no striking work, but is provided with a kind of alarm, which after each hour rattled the hammer to and fro on a bell to call the watchman to his duty of announcing the hour to the people. The motion-work consists of a barrel wheel with 96 teeth, a vertical wheel with 35 teeth, and a 5-leaf pinion. The baael wheel has a 4-leaf pinion seizing into 48 teeth of the hour wheel. In the former division of 16 hours, the hour wheel had 64 teeth. The verge is suspended to a cord, and is in place of the balance, provided with a horizontal, toothed bar, on the ends of which hang two small square weights so as to regulate the clock, and are thereby removed more or less from the center of the verge.

The winding part is peculiar, because, while the cord with the thereon suspended weight descends, another cord with a small weight winds up in an opposite direction, whereby it was simply necessary to draw down the small weight in order to wind the heavier, and to preserve the clock in motion.

A pin *a* is drilled into the barrel wheel, which makes one revolution every hour; the former unlocks the lever *b*, and actuates the alarm; but since it is the purpose of the alarm to prolong sounding for about one quarter of a minute, the following simple arrangement has been introduced. While the lever *b*, on the movable part *c*, is raised up by the pin *a*, it liberates the wedge *d*, which, when the alarm is at rest, leans on the lever arm *e*, so that the alarm wheel with one winding sets the hammer into activity.

Ordinarily, it would take some time until the pin has *a*, with its movable part *c*, passed the lever *b*, and the alarm would in conse-

quence run down after having rung once. To prevent this the angle  $i$  is riveted upon the circumference of the alarm wheel, opposite to the wedge  $d$ , which, after a half revolution of said wheel, still lifts up a part of the lever arm  $e$ , so that the part  $e$  falls downward by its own weight, and leaves the pin  $a$  free, so that the lever arm  $e$  again assumes its place upon the face of the alarm wheel, and the wedge  $d$ , in its further half revolution, places itself against it in order to place the alarm into repose, until the same performance is repeated an hour afterward.

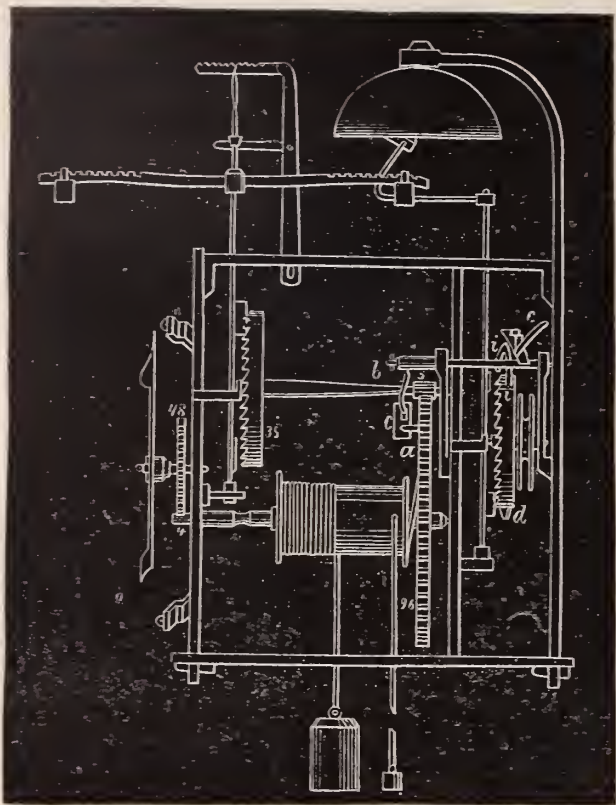

Simple and unassuming though this piece of handicraft of past centuries be, it embraces a wealth of ideas in its construction, and we can do no less than admire the old masters, who, with their few miserable tools, vanquished the greatest of difficulties, under the most obstinate of circumstances, and thereby are fully entitled to the honor of being the fathers of one of the largest industries of modern times.

[Copyright Secured.]

### Letters to Watchmakers.

[By DR. LEONARD WALDO, Astronomer in charge of the Horological Bureau of the Yale College Observatory.]

#### IV.

##### HOW TO OBTAIN THE TIME.

THE CAUSES which disturb the regular going of an apparently good clock are many of them obscure. Some of them are pretty well established by experiment and observation. Thus the effect of a change of the barometer is to alter the density of the air and the friction therefore which takes place between the pendulum and the air as it swings, and between the clock case the air and the pendulum varies with the effect of retarding the pendulum more or less. The clock weights as they fall near the bob or even as they alter their position with reference to the pendulum rod introduce another change in the currents of the air made by the swinging pendulum. Then, too, the weights exercise another but not well observed effect by their attraction on the bob as they are lowered to its level.

The suspension spring is very seldom free from a decided wobble which can be shown in a marked manner by attaching a plain mirror to the pendulum bob or rod, and observing the motion of the

reflected point as the observer looks into the mirror. If the pendulum described its arc in a single plane as it should, then the reflected image would remain in a fixed position. Of course, any gyrations of the pendulum as it swings takes from the time of its vibration and alters the rate of the clock. Very few clocks are properly compensated. You cannot add any fixed amount of mercury or have any given height of lead for a compensated pendulum. The compensation differs for every piece of steel, or iron or zinc involved. The effect of temperature changes on the elasticity of the suspension spring and on the expansion of metallic pendulums is so great that each clock should be compensated by itself, and this is seldom done by the makers. Then, to these less apparent imperfections are to be added these from faulty proportions of train to pendulum, faulty suspension of the entire clock and bad oil.

It is not too much to say, therefore, that for the highest class of watches the ordinary "jewelers' regulator" is trustworthy as a standard of reference for daily trials of a fine watch's rate, unless it is constantly compared with time signals from some observatory or with the stars themselves from the astronomer ascertains the time. With the methods in use in various parts of the United States to give the watchmakers and jewelers time from astronomical observatories, every watchmaker in a large city is more or less familiar. They should remember that even "observatory time" is frequently inaccurate—often to the extent of a single second—sometimes two or three seconds. Whether these errors are noticed by the watchmaker generally depends on the method adopted by the observatory for recovering from an error of more than one second. Thus, suppose that from not having observed the stars owing to cloudy weather, an observatory finds its clock about one and a half seconds fast. If the clock is stopped for one and a half seconds, some of the watchmakers who are rating chronometers or clocks by the telegraph time signals, will discover that the clock has been slowed by one and one-half seconds and the daily rate of the timepieces rated on that day will show an abnormal deviation. If, however, the observatory merely removed a small weight from its standard clock so that it would take several days to lose the one and a half seconds, then this change would be distributed over several days, and except for the very finest ratings the error would not be harmful.

Observatory clocks, though of a high accuracy of construction, are liable to the daily changes which are easily discovered by observation of stars but which cannot be foretold. For very accurate rating, therefore, the watchmaker had better apply to the observatory for the corrections to the telegraphed time on the days on which he used it. I think he will find the observatories always willing to answer inquiries on the subject.

The determination of the true time from direct observation of the stars is a simple matter, though there are so many methods that the choice of the simplest depends on the local surroundings and the observer's taste for computing.

Suppose the watchmakers to have procured a transit instrument (which ought not to be of less than one and a half inches clear aperture), and say that he desires to observe for and obtain the time with the very smallest amount of computing, but that he is willing to take the care necessary to accurately set and adjust his transit; how shall it be accomplished? In the first place he will want to know his geographical position, particularly if he wishes to compare his time with the time sent to him from some observatory. Here is a very accurate table of the local times at various cities when it is noon at the Naval Observatory at Washington. This table, originally compiled for the Western Union Telegraph Company, has been made up from the best determinations of the government surveys and may be relied upon. In order to convert the times here given into the times of the  $V^{\text{th}}$  or other hours west of Greenwich, England, it must be remembered that Washington (Naval Observatory) is  $5^{\text{h}} 8^{\text{m}} 12.809$  west of Greenwich, and, therefore, that  $8^{\text{m}} 12.809$  must be added to the times given for places east of Washington, and must be subtracted for places west of Washington, if it is desired to com-

pare the local time with the time telegraphed from some observatory which has adopted the new system of time standards.

Mean time at various places, at Washington mean noon.

| City.               | State. | Points to which the Longitude is referred.   | Mean time when it is noon at Washington. |       |       |
|---------------------|--------|--|--|-------|-------|
|                     |        |  | H.                                       | M.    | S.    |
| Atlanta.....        | Ga.    | City Hall or Court House.....  | 11                                       | 30    | 38.61 |
| Albany.....         | N. Y.  | Dudley Observatory, Dome.....  | 12                                       | 13    | 12.34 |
| Allegheny City..... | Pa.    | Allegheny Observatory, Dome.....   | 11                                       | 48    | 9.16  |
| Bridgeport.....     | Ct.    | Spire, Middle Bridgeport (1834).....   | 12                                       | 15    | 26.42 |
| Bangor.....         | Me.    | { C. S. Astro'l Station on Thomas Hill, }<br>near cor. Union and James streets }   | 12                                       | 33    | 4.17  |
| Baltimore.....      | Md.    | Washington Monument.....   | 12                                       | 1     | 44.13 |
| Boston.....         | Mass.  | State House.....   | 12                                       | 23    | 56.74 |
| Brooklyn.....       | N. Y.  | City Hall.....   | 12                                       | 12    | 14.28 |
| Buffalo.....        | "      | Van Duzee's Observatory.....   | 11                                       | 52    | 43.81 |
| Chicago.....        | Ill.   | City Hall or Court House.....  | 11                                       | 17    | 40.20 |
| Covington.....      | Ky.    | .....  | .....                                    | ..... | ..... |
| Cambridge.....      | Mass.  | Harvard College Ob'y, center of Dome.....  | 12                                       | 23    | 41.11 |
| Charlestown.....    | "      | Bunker Hill Monument.....  | 12                                       | 23    | 57.44 |
| Chelsea.....        | "      | Neptune House, Flagstaff.....  | 12                                       | 24    | 17.03 |
| Camden.....         | N. J.  | Church Spire.....  | 12                                       | 7     | 42.69 |
| Cincinnati.....     | O.     | Mitchel's Old Observatory (1848).....  | 11                                       | 30    | 13.05 |
| Cleveland.....      | "      | Marine Hospital, Dome.....   | 11                                       | 41    | 26.39 |
| Columbus.....       | "      | Dome of Capitol.....   | 11                                       | 36    | 13.13 |
| Charlestown.....    | S. C.  | St. Michael's Church.....  | 11                                       | 48    | 28.84 |
| Davenport.....      | Iowa.  | Court House.....   | 11                                       | 5     | 53.5  |
| Dubuque.....        | "      | Center of the City (1859).....   | 11                                       | 5     | 32.4  |
| Detroit.....        | Mich.  | U. S. Lake Survey, New Observatory..   | 11                                       | 35    | 59.88 |
| Dayton.....         | O.     | .....  | 11                                       | 31    | 28.—  |
| Evansville.....     | Ind.   | .....  | .....                                    | ..... | ..... |
| Elizabeth.....      | N. J.  | Presbyterian Church Spire.....   | 12                                       | 11    | 20.25 |
| Erie.....           | Pa.    | { U. S. Lake (about 2,400 feet west }<br>Survey " 6,800 " south }<br>Station. { of Pier Light House. }                               | 11                                       | 47    | 50.83 |
| Fall River.....     | Mass.  | Derrick.....   | 12                                       | 23    | 32.36 |
| Hartford.....       | Ct.    | Old State House.....   | 12                                       | 17    | 30.53 |
| Hoboken.....        | N. J.  | Long Dock, C. S. Station.....  | 12                                       | 12    | 5.37  |
| Harrisburg.....     | Pa.    | .....  | 12                                       | 0     | 52.—  |
| Indianapolis.....   | Ind.   | .....  | 11                                       | 23    | 52.—  |
| Jersey City.....    | N. J.  | Gas Works, Chimney.....  | 12                                       | 12    | 2.49  |
| Kansas City.....    | Mo.    | .....  | .....                                    | ..... | ..... |
| Kingston.....       | N. Y.  | .....  | .....                                    | ..... | ..... |
| Louisville.....     | Ky.    | .....  | 11                                       | 26    | 12.—  |
| Lawrence.....       | Mass.  | .....  | .....                                    | ..... | ..... |
| Lowell.....         | "      | .....  | 12                                       | 22    | 56.—  |
| Lynn.....           | "      | East Church, Green Tower.....  | 12                                       | 24    | 27.06 |
| Lancaster.....      | Pa.    | .....  | 12                                       | 2     | 59.9  |
| Mobile.....         | Ala.   | Episcopal or Christ Church, Steeple...   | 11                                       | 16    | 1.96  |
| Manchester.....     | N. H.  | .....  | .....                                    | ..... | ..... |
| Memphis.....        | Tenn.  | .....  | 11                                       | 7     | 40.—  |
| Milwaukee.....      | Wis.   | .....  | 11                                       | 16    | 35.—  |
| Mew Haven.....      | Ct.    | Yale College, Middle Spire.....  | 12                                       | 16    | 29.12 |
| New Orleans.....    | La.    | U. S. Mint, C. S. Station on chimney..   | 11                                       | 7     | 58.26 |
| New Bedford.....    | Mass.  | Baptist Spire.....   | 12                                       | 24    | 29.68 |
| Newark.....         | N. J.  | Presbyterian Church.....   | 12                                       | 11    | 30.57 |
| New York.....       | N. Y.  | City Hall.....   | 12                                       | 12    | 10.47 |
| Nashville.....      | Tenn.  | University.....  | 11                                       | 20    | 55.9  |
| Norfolk.....        | Va.    | City Hall.....   | 12                                       | 3     | 2.64  |
| Peoria.....         | Ill.   | .....  | .....                                    | ..... | ..... |
| Portland.....       | Me.    | Unitarian Church, Park street.....   | 12                                       | 27    | 9.07  |
| Paterson.....       | N. J.  | .....  | .....                                    | ..... | ..... |
| Poughkeepsie.....   | N. Y.  | New Dutch Reformed Church.....   | 12                                       | 12    | 28.75 |
| Philadelphia.....   | Pa.    | State House, Steeple.....  | 12                                       | 7     | 35.92 |
| Pittsburg.....      | "      | Post Office.....   | 11                                       | 48    | 12.08 |
| Providence.....     | R. I.  | Unitarian Church.....  | 12                                       | 22    | 34.80 |
| Quincy.....         | Ill.   | .....  | .....                                    | ..... | ..... |
| Rochester.....      | N. Y.  | { U. S. Lake (about 300 feet north }<br>Survey " 360 " west }<br>Station. { of City Hall. }  | 11                                       | 57    | 41.46 |
| Reading.....        | Pa.    | .....  | .....                                    | ..... | ..... |
| Richmond.....       | Va.    | Capitol.....   | 11                                       | 58    | 27.82 |
| San Francisco.....  | Cal.   | C. S. Astro'l Station, Washington Sq..   | 8  | 58    | 33.74 |
| Savannah.....       | Ga.    | Exchange, Spire.....   | 11                                       | 43    | 50.25 |
| Salem.....          | Mass.  | S. Church, cor. Cambridge & Chestnut sts   | 12                                       | 24    | 36.19 |
| Springfield.....    | "      | Court House.....   | 12                                       | 17    | 49.—  |
| St. Joseph.....     | Mo.    | .....  | .....                                    | ..... | ..... |
| St. Louis.....      | "      | Court House.....   | 11                                       | 7     | 26.67 |
| St. Paul.....       | Minn.  | S. E. corner New Court House.....  | 10                                       | 55    | 49.92 |
| Syracuse.....       | N. Y.  | Court House, center.....   | 12                                       | 3     | 34.70 |
| Scranton.....       | Pa.    | .....  | .....                                    | ..... | ..... |
| Taunton.....        | Mass.  | .....  | 12                                       | 23    | 48.—  |
| Trenton.....        | N. J.  | Presbyterian Church, Spire.....  | 12                                       | 9     | 8.74  |
| Troy.....           | N. Y.  | .....  | 12                                       | 13    | 25.40 |
| Toledo.....         | O.     | { U. S. Lake (about 190 feet west, }<br>Survey " 190 " north of }<br>Station { Monument, intersection }<br>Monroe and Ontario sts. } | 11                                       | 34    | 2.24  |
| Utica.....          | N. Y.  | Dutch Church.....  | 12                                       | 7     | 20    |
| Wilmington.....     | Del.   | Town Hall.....   | 12                                       | 5     | 59.87 |
| Worcester.....      | Mass.  | .....  | 12                                       | 20    | 59.—  |
| Watervliet.....     | N. Y.  | Arsenal.....   | 12                                       | 13    | 32    |

From this table of longitudes, the longitude of some point near the watchmaker can be taken out. From some reliable map it will be necessary to find the distance due east or west which the transit is to be from the point whose longitude has been taken from the table. Of course, as we go north the meridians of longitude approach each other, and the value of a mile in an east or west direction in time increases. In the following table is given the value of a degree of longitude or its equivalent of minutes of time for the latitudes met with in the United States.

Table showing the length in statute miles of one degree (fifteen minutes of time) of longitude at various latitudes:

| Latitude. | Length of one degree, 15 minutes of time. |
|-----------|---|
| 30°       | 59.948                                    |
| 31        | 59.338                                    |
| 32        | 58.709                                    |
| 33        | 58.063                                    |
| 34        | 57.399                                    |
| 35        | 56.718                                    |
| 36        | 56.019                                    |
| 37        | 55.304                                    |
| 38        | 54.571                                    |
| 39        | 53.822                                    |
| 40        | 53.056                                    |
| 41        | 52.274                                    |
| 42        | 51.476                                    |
| 43        | 50.662                                    |
| 44        | 49.833                                    |
| 45        | 48.988                                    |
| 46        | 48.128                                    |
| 47        | 47.254                                    |
| 48        | 46.365                                    |
| 49        | 45.462                                    |
| 50        | 44.545                                    |

It will be a simple matter, therefore, to get a pretty accurate value of one's geographical position by adding to or subtracting from the point whose longitude is given in the first table, the time corresponding to the measured distance obtained from the second table.

### The Cincinnati Relief Fund.

WE HAVE received from Mr. Dueber, of Cincinnati, a statement of the disposition made of the money contributed, recently by the jewelers of the country for the relief of the sufferers by the flood in the Ohio river. Accompanying it is a list of all the contributors, and an itemized statement of disbursements. This would occupy altogether too much space to warrant us in printing it in full. Suffice it to say that Mr. Dueber received in all \$11,387.33, which sum, with the exception of \$2,298.60, which he still holds, he distributed among the suffering and needy persons who lost their property, their homes, and, in many instances, all they possessed by the flood. Mr. Dueber was constituted the representative of the jewelry trade, and so long as it was necessary he gave his services night and day with other prominent citizens to the work of relieving distress. Not only did he disburse the fund entrusted to him, but he contributed \$500 himself, furnished men, wagons and horses to aid the relief committees, and personally superintended a soup house where over 54,000 meals were served, consisting of soup, bread, coffee, rice, etc. At a time when the best energies of the charitably disposed were needed to relieve the suffering caused by a great and widespread disaster, the jewelry trade have reason to be proud of the share taken in the good work by their representative. The general government, state, city and town authorities did more than was expected of them, and more than usual in such cases, which accounts for the fact that the whole of the amount contributed by the jewelers was not required, a balance of \$2,298.60 remaining unexpended in Mr. Dueber's hands; what disposition to make of this balance is a matter for future consideration. Among those who were particularly active in obtaining contributions was Mr. Hamilton, of Providence, who canvassed the trade in that city, Attleboro and Plainville

very thoroughly, and is entitled to much credit for the service rendered. The alacrity with which the trade responded to this cry of distress furnishes another illustration of the liberality and sympathetic spirit that characterize its members.

The idea occurs to us, and we presume it does to others, that Congress should provide an emergency fund to meet great calamities that befall communities from time to time. Scarcely a year passes that some community is not overwhelmed in some catastrophe which could neither be foreseen nor provided against, and appeals to the liberality of the benevolent are rendered necessary. That this constitutes a very considerable tax upon them is shown by the contribution of over \$11,000 by the jewelry trade through this one source; if their contributions had all been made through one channel we have no doubt they would have shown an aggregate of \$20,000 at least. If the Secretary of the Treasury, or some department of the national government was authorized to expend such sums as might be necessary in cases of disaster, there would be no occasion for appeals to the public, the sufferers would obtain relief much more speedily, and the burden of cost would be shared by all taxpayers instead of being born by the benevolent few. This would be far more equitable and fully in accord with the paternal features of our government. We append a summary of the contributions forwarded to Mr. Dueber:

|                            |           |                        |             |
|----------------------------|-----------|------------------------|-------------|
| Cincinnati, O.....         | \$ 932 64 | Kennardale, Pa.....    | \$ 1 00     |
| Newport, Ky.....           | 757 35    | Oskaloosa, Iowa.....   | 2 00        |
| Chicago, Ill.....          | 1,722 54  | Indianapolis, Ind..... | 5 00        |
| Phila., Pa.....            | 506 00    | Hannibal, N. Y.....    | 50 00       |
| New York.....              | 1,830 00  | Stroudsburg, Pa.....   | 25 00       |
| Providence & Vicinity..... | 3,310 50  | Windsor, Mo.....       | 2 25        |
| Boston.....                | 285 00    | Painsville, O.....     | 6 00        |
| San Francisco.....         | 187 00    | Ash Grove, Mo.....     | 42 75       |
| Pittsburgh.....            | 25 00     | Jackson, O.....        | 5 00        |
| Newark, N. J.....          | 227 50    | Anderson, Ky.....      | 5 00        |
| St. Louis.....             | 193 00    | Berne, Ind.....        | 5 00        |
| Cleveland.....             | 141 00    | Waterbury, Conn.....   | 90 00       |
| Hartford, Conn.....        | 200 00    | Berea, O.....          | 5 00        |
| Canton, O.....             | 1 00      | Lafayette, Ind.....    | 10 00       |
| Marion, Ind.....           | 5 00      |                        |             |
| Preston, Minn.....         | 2 00      |                        |             |
| Elgin, Ill.....            | 792 80    |                        |             |
|                            |           |                        | \$11,387 33 |

Time and Timekeepers.

BY J. ASHER.

IN NATURE time is measured by the motions of the celestial bodies. A year is the time the earth requires to travel round the sun. A month is little more than the time occupied by the moon in its journey round the earth. The week is nearly the time of a moon's quarter. A mean solar day is the average time that passes between the transits of the sun across a meridian. A sidereal day is the time the earth requires to turn once on its axis. It is determined by the apparent motion of the stars, and it is 3' 56" shorter than the mean solar day.

The year contains nearly 1/4 of a day more than 365 as usually given in the calendar. But were the fraction not reckoned in 751 years the summer solstice would be December 21, and the winter solstice June 21. The error amounts to almost a day in 4 years, and to partially correct it we add one day to the calendar. February was formerly the last and shortest month, hence the leap day was given to it. But there is still an error, for the year contains 11' 12" less than 365 1/4 days. To partially correct the excess one leap-day is omitted at the end of three-fourths of the centuries. If the first two figures of a centurial or the last two figures of any other year are divisible by 4 it is leap year. Thus, 1600 was leap year for 16 is divisible by 4; 1876 was leap year for 76 is divisible by 4. The year 1883 was not leap year because a number remains when 83 is divided by 4. The remainder shows what 1883 was, the third after leap year.

January was named from Janus, an old Italian deity, the god of

the sun and the year. February is derived from *februare*, to purify. In this month was the feast of expiation. March—from Mars the god of war. April—from *aperire*, to open. In this month the earth opens for new vegetation. May was named in honor of the goddess Maia, daughter of Atlas and mother of Mercury, by Jove. June—from the goddess Juno, wife and sister of Jupiter, and queen of heaven. July was so named in honor of Julius Cæsar. August—from Augustus Cæsar. September is derived from *septem* the Latin for seven. The year formerly began March 6, hence September was the seventh month. October—from *octo*, eight. November—from *novem*, nine. December—from *decem*, ten.

The week days were named in honor of ancient deities.

Sunday, in honor of the sun.

Monday, in honor of the moon.

Tuesday, from Tui, a Gothic hero.

Wednesday, from Woden, a Gothic god.

Thursday, in honor of Thor, chief god of the Goths.

Friday, from Frigg, the wife of Woden.

Saturday, in honor of Saeter, a northern god.

The day of the week for any date in this century may be found by the following rule: Add together the last two figures of the year, their integral fourth part, the day of the month and a number belonging to the month. Divide the sum of these numbers by 7; the remainder is the number of the week day. Here are the numbers for the month.

|          |    |           |    |
|----------|----|-----------|----|
| January  | 3. | July      | 2. |
| February | 6. | August    | 5. |
| March    | 6. | September | 1. |
| April    | 2. | October   | 3. |
| May      | 4. | November  | 6. |
| June     | 0. | December  | 1. |

In leap year the numbers for January and February are 2 and 5 respectively.

*Example 1.* What day of the week was June 18, 1815—the date of the battle of Waterloo?

Solution:

|                                     |         |
|-------------------------------------|---------|
| year                                | 15.     |
| fourth part of 15 without remainder | 3.      |
| day of the month                    | 18.     |
| number for June                     | 0.      |
| sum                                 | 7   36. |
|                                     | 5—1.    |

The remainder indicates the first day of the week which is Sunday. When there is no remainder Saturday is indicated. It is the seventh day of the week, and we never get seven for a remainder because we divide by this number. Days of the week in last century may be found if 2 is added before performing the division.

*Example 2.* What day of the week was July 4, 1776?

Solution:

|                         |          |
|-------------------------|----------|
| year                    | 76.      |
| fourth part of 76       | 19.      |
| day of the month        | 4.       |
| number for July         | 2.       |
| number for last century | 2.       |
| sum                     | 7   103. |
|                         | 14—5.    |

*Ans.* The fifth day of the week—Thursday.

The transit instrument is a telescope mounted at right angles on an axis, the ends of which are supported on stone piers to insure steadiness. The instrument is set so as to turn in the meridian. Five fine wires are stretched at equal distances apart across the inner focus of the eyeglass. With this instrument we can find what time a clock shows when a celestial body crosses the meridian. When the transit instrument shows that a star is on the meridian a clock may be set with the correct time, for all that is then necessary is to consult prepared astronomical tables which give the culmination of that



particular star. Five wires are used to obtain great accuracy. By noting to the fraction of a second the time at which the star passes each wire, and taking the mean of all, the time of the star's culmination or meridian passage may be found with great precision. The wires must be slightly illuminated when the instrument is used at night. The time may be found by taking in a similar manner the meridian passage of the sun's center. The following is one method of setting a transit instrument in the meridian. Place the instrument as nearly as possible in the meridian by estimation, then notice by an excellent timekeeper the duration between the upper and lower transits of the polar star across the middle wire. If 11h. 52' 2" elapse between the passages of the star across the wire the instrument is in the meridian. The polar star is not quite in the zenith of the north pole, hence in 23h. 56' 4" it appears to describe a small orbit in the sky. This apparent orbit is not quite circular because of the nutation of the earth's axis. The motion of the earth on its axis is almost absolutely uniform. It has not varied  $\frac{1}{100}$  of a second in centuries. Its motion, however, is being very gradually retarded by the tides which act as brakes. The day will be about one minute longer in a million years hence.

Sun dials were in use in the time of Ahaz. The first sun dial in Rome was set up by Lucius Papirius Cursor, B. C., 307. Sun dials are useless on cloudy days and at night. The index or gnomon of the dial points toward the polar star, consequently, if the place is N. of the equator, the N. end has an elevation equal to the latitude of the place. The sun dial is quite incorrect in the morning and in the evening, because of the great atmospheric refraction of the solar rays when the sun is near the horizon.

Clepsydræ were used in Greece by Plato. They depended upon the rising level of water in a vessel supplied from a small hole in the bottom of another above it, the upper being constantly kept full to insure a uniform flow of water. Wheels and hands were applied to the clepsydræ by Ctesibus, of Alexandria, B. C. 145.

Hour glasses were used in early times. The hour glass consists of two connected conical glass vessels, one of which is filled with fine sand. When the filled vessel is uppermost the sand slowly trickles into the lower through a small hole in the waist of the instrument. In a modified form the sand glass is now used to time the boiling of eggs. This instrument is mounted on a horizontal axis in an inclined position, and when the proper quantity of sand passes into the lower end the instrument suddenly turns and a hammer strikes a small bell.

Burning candles were formerly used to measure time by the Saxons. Marks on the candle represented hours and their fractions.

Sometimes small brass balls were inserted into the tallow, and when the latter was consumed to the proper point they fell into a brass pan causing tinkels and thus told the hour.

The first clock or wheelwork driven by a weight to measure time was invented by Gerbert, in the year 996. Gerbert was a man of the highest ability, and he possessed an uncommon genius for mechanical invention. He afterwards became Pope Silvester II. Galileo and Huyghens applied the pendulum to clocks about the beginning of the seventeenth century. This was a very great improvement. Even now nothing else that man has invented is equal to the pendulum for good timekeeping qualities. This is due to the isochronism of its vibrations; that is, it will swing in almost exactly the same time whether its arc of vibration be great or small. Dr. Hooke, of the Isle of Wight, in 1658 invented the anchor or recoil escapement. This is still used in nearly all common clocks. The vertical escapement was used in clocks until supplanted by Hooke's invention. The dead beat escapement was invented by George Graham, a watchmaker of London, about the beginning of the last century. There is less friction in the dead beat escapement than in the recoil, for the wheels do not retreat a little at each beat as in the other. Besides the second hand of a clock provided with the dead beat escapement stops dead at the seconds marks on the dial, and presents a fine appearance of neatness and precision. You may see this in jewelers' regulators.

The length of a common pendulum varies with the temperature and affects the rate of the clock. Compensating pendulums depend upon the unequal expansibility of different metals. The mercurial pendulum was invented by Graham in the year 1719. It consists in a steel rod, with a stirrup at the lower end containing a glass jar nearly full of mercury. When a change of temperature occurs, the lengthening or shortening of the rod is compensated by the opposite movement of the column of mercury. Harrison invented the grid-iron pendulum about the year 1727. It consists of 5 steel and 4 brass rods, parallel to each other. Several cross bars are attached to these rods. The bob is suspended beneath the latter.

My pendulum was patented in the United States, April 4, 1882. To the brass frame of the clock one end of a brass lever is attached by a pivot. A brass rod fastened to the frame extends downwards and fixed to its lower end, and extending upwards is a zinc rod the upper end of which supports the lever. To the free end of the lever the pendulum is suspended over a slit stud on the frame. The pendulum spring passes through the slit stud. When the temperature rises the pendulum rod lengthens, but the brass and the zinc rod also lengthen, but the zinc lengthens more than the brass and raises the longer arm of the lever. Consequently the pendulum spring is pulled up a little way through the stud. The reverse occurs when the temperature falls.

The changes of air pressure cause a clock to vary slightly. These sometimes cause a rate change of  $\frac{3}{10}$  of a second in 24 hours. To prevent this, Rittenhouse attached a large, hollow and light ball to the top of the pendulum and in the opposite direction to the bob. An air-tight clock-case is sometimes used, the winding arbor passes through a stuffing box. Dr. Robinson attached a pair of barometers to the pendulum rod above the bob. This has the effect of raising a little mercury from the bottom to the top of the pendulum when the air pressure increases, and of lowering a little from the top to the bottom when the air pressure diminishes. The barometric compensation is applied to the sidereal clock at Greenwich in the following manner: A barometric column raises or lowers a magnet which attracts the pendulum more or less. Sir Edmund Becket justly considers this a round about method. Harrison invented the "maintaining power" for clocks about the middle of last century. A clock provided with this invention keeps time even whilst it is being wound.

Watches were invented in Nuremberg, Germany, about the year 1477. They were as large as tea cups, and were called Nuremberg eggs. King Edward VI., of England, had a timepiece driven by weights which were suspended in front of his body. All those old timekeepers had only an hour hand. Dr. Hooke invented the spiral balance spring about 225 years ago. This spring has the property of isochronism.

Facio, of Geneva, invented the art of boring rubies and other hard stones for use in watches. The pivots revolve in the holes with little friction. Harrison invented the chronometer and gained the great reward of £20,000 from the British government.

Many watch escapements have been invented. The first was the vertical escapement. It is due to De Vick who lived 600 years ago. It was used in clocks until Hooke invented the anchor escapement. Nearly all watches had the vertical escapement until the year 1700. The old turnips have it. A watch cannot well be made thin if it has this escapement, for there must be a clear space between the plates greater than the diameter of the scape wheel whose axis is at right angles to the axis of the other wheels. The cylinder escapement is due to Tompion and Graham. It is suitable for very small watches as it requires little space. The duplex escapement was invented by Dutertre and Tyrer. It will run only in the care of quiet persons for it may stop when shaken. The lever escapement was invented by Berthoud and Mudge about a century ago. It is the best for general use. The chronometer escapement was invented by Julian Le Roy, and improved by Arnold and Earnshaw. It is the best for accuracy when the watch is kept in one position. The

compensation balance was invented by Earnshaw. The stem winder and luminous dials were invented during the present century.

A reform in the method of timekeeping had long been desirable, especially in relation to the running of railway trains. Until November 18, 1883, about 50 different standards of time were used by the railway companies of North America. By the new arrangement the continent is divided into gussets of 15 degrees of longitude each or one hour of time. The meridian that passes through the center of the great transit instrument in the national observatory at Greenwich, England, is the zero whence these degrees are reckoned. All who reside in our gusset should use time of the 75th degree of W. longitude, or exactly 5 hours slow of Greenwich mean solar time. Those who live in the next gusset west use the time of the 90th degree, consequently their time is 6 hours slow of Greenwich. This arrangement will probably be convenient to most persons except those who live on or near the lines where the time changes. Every person may not know in which gusset he is situated. Imaginary lines only are used, hence it will be annoying to many in those localities for some time.

### Removals.

J. W. Todd has removed to 20 Maiden Lane.

Marx & Weis have removed to 180 Broadway.

H. H. Heinrich has removed to 18 John street.

W. J. Suttie is now comfortably settled in 28 John street.

Leroy C. Fairchild & Co. have removed to 10 Maiden Lane.

Jacot, Juillerat & Co. will occupy rooms in No. 37 Maiden Lane.

The Jewelers' League will occupy room No. 5 of No. 170 Broadway.

C. T. Voelker has removed to more desirable quarters in 15 Maiden Lane.

The Jewelers' Protective Alliance has secured an office in No. 170 Broadway.

American Morocco Case Co. have removed their office from the 4th to the 2d story of 9 Bond street.

The Illinois Watch Co., of Springfield, will occupy more commodious quarters in No. 3 Maiden Lane, after May 1st.

The Gorham Manufacturing Co. expect to occupy their new building, corner 19th street and Broadway, about the middle of May.

Reed & Barton will occupy No. 37 Union Square, the store made vacant by the removal of the Gorham Manufacturing Co., and hope to be settled early in June.

John A. Riley & Co., Thos. G. Brown & Sons, S. Cottle Co., Taylor & Bro. and Dominick & Haff will occupy desirable quarters in the new building corner 17th street and Broadway, known as 860 Broadway, May 1st.

### Sailed for Europe.

J. Eugene Robert and family sailed April 17th in the *Werra*, and will remain abroad during the summer. Moses Kahn, of Messrs. L. & M. Kahn & Co., also sailed in the same steamer. Mr. Kahn is expected to return early in the fall. M. A. Myers, of Messrs. S. F. Myers & Co., left on the 19th in the steamer *Rome* for a much needed rest. S. Oppenheimer, of Messrs. Oppenheimer Bros. & Veith, sailed on the steamer *Eider* which left this port on the 30th ult. Edward Dreyfus, of the firm of Levy, Dreyfus & Co., left in the *Normandie* April 16; will return in time for the fall trade with many novelties in their line. Stephen Pell will sail in the steamer *America* May 28th. S. Freund will leave in the *Werra* May 14th. M. Weis, of the firm of Marx & Weis, sailed in the *Werra* April

16. Sumner Blackinton, of W. & S. Blackinton, sailed in the *Normandie* April 16, for an extended tour through Europe. Louis Neresheimer, of E. Aug. Neresheimer & Co., expects to leave in the *Eider* May 28th. J. N. Bonnet, of Messrs. Mulford & Bonnet, left in the *Aurania* April 20th, to make his fall purchases of diamonds. George A. French, with Messrs. W. S. Hedges & Co., diamond importers, makes his maiden visit to Europe in the *Bohemia*, March 26th, in search of goods for the house. S. C. Scott, of J. T. Scott & Co., expects to leave in the *Britannic* May 10th. A. J. Grinberg and Leopold Goodman, of Grinberg, Goodman & Pollack, sailed for Europe April 30th in the *Eider*.

### A Review of the Different Gravity Escapements.

A GRAVITY ESCAPEMENT, sometimes called a remontoir escapement, is one in which the impulse is not imparted to the pendulum direct by means of the drawing weight, but by a smaller weight or a small spring introduced for this special purpose, and which operates upon the former at each oscillation. The great advantage is obtained hereby that the impulse is always constant, because the only consequence of a variation in the traction power, of the best clocks even, is due to the difference whether the weights are wound faster or slower, which has, in this instance, no influence upon the pendulum, because the winding is performed always when the latter is out of the way. If the latter operation can be performed correctly and without exposing the pendulum to a material variation of the friction in the unlocking of the escapement which it performs, its motion must then be absolutely constant as well as its time of performance, since no disturbing event takes place beside this. This would, at first sight, not appear to be a difficult problem, and yet it has set the watchmakers a thinking for almost a century because a secondary pivot was left unobserved. The problem was finally not even solved by watchmakers but by two lawyers.

Let us consider first, in order to clearly understand the theory, a simple form of gravity escapement, to wit, that of MUDGE.

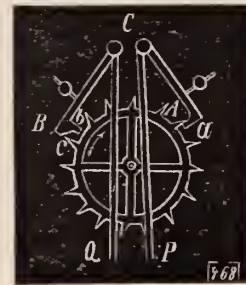

FIG. 1.

We find it sketched in fig. 1. The pallets *AC*, *BC*, are here not situated on one but on two points of revolution. The operative parts are shaped and disposed of in such a manner that when the wheel revolves from *B* to *A*, a tooth raises one of the two pallets until the shoulder *a* or *b* retains it. This condition of affairs has in the figure ensued at *A*; as soon, now, as the pendulum moves to the right, the pallet is lifted by means of the part *P* and the tooth at *a* becomes free; the wheel begins to turn, and at the same moment the tooth at *b* will unlock the pallet *B* since it slides along the oblique face *c*, until the same condition ensues here as we saw it just now at *A*. The shoulder *b* will, therefore, retain the corresponding tooth. While the pendulum now oscillates, for instance, upon the right side, that is, mounts, it carries the corresponding pallet along; in falling it presses upon it, and the pallet does not alone return to the place where the pendulum has taken it up, but a quantity deeper similar as at *B*. The fall of the pallet weight from the place where it was taken up by the pendulum, up to the place where the latter lets it go, or the difference between its rising and falling with the pendulum constitutes its impulse. This difference is always constant no matter how great the amplitude of the pendulum may be.

If the pallet weights would counterbalance each other, either in whole or in part, and be moved by a spring in place of their own weight, we would have no gravity escapement, but one known by the general name of remontoir escapement. The principle remains the same thereby, in so far as the law governing the force of springs does

not itself come into consideration, wherefore this escapement is also more variable than the former.

It is easily demonstrated that the effect of the gravity escapement causes a far more rapid oscillation than takes place by the fall, if we consider that the remontoir weights actually form the force imparted to the pendulum outside of its center of oscillation. This, however, does not cause the variation when the arc of amplitude increases or diminishes for certain reasons, for instance, friction. With regard to this, a very remarkable result is obtained by calculation.

MUDGE'S gravity escapement, which was in great favor in the year 1850, and was much used in the French tower clocks at the London Exposition of 1851, showed great defect. Because, by increasing the weights of the clock, the arc of oscillation also increased, which stands in direct opposition to the fundamental principle of the gravity escapement; wherefore the escapement was not generally adopted.

CUMMING'S gravity escapement was constructed according to a similar principle, and in order that the shoulders *b* or *a* (in above figure) should cause no irregularities in case the pallets would be unlocked too high, they were arranged by themselves around special pivots.

HARDY'S gravity escapement.—Since Cumming's escapement contained no less than 8 points of revolution, which caused a great deal of friction, Hardy arranged several of these parts upon springs instead of around points of revolution.

KATER'S escapement.—Captain Kater took a great interest in the theory of the pendulum, and his gravity escapement is described in the *Philosophical Transactions*, vol. 130. In place of the two parts *P* and *Q* with their pallets an anchor is used.

GOWLAND'S escapement had in place of the pallets a pair of small weights on long arms in order to reduce the friction to a minimum. Similarly constructed was the escapement of GANNERY, a French watchmaker.



FIG. 2.

The only one of all these escapements which had greater vitality, is that of BLOXAM. It is sketched in fig. 2. The pallets *A C* and *C B* are alternately raised almost without friction by a small wheel with nine teeth located in the center. *A* and *B* are mounted pieces of repose; *E* and *F* accommodate the pendulum. The motion center at *C* are identical with that of the pendulum, and the radius of the wheel always results from the length of *A C* and *B C* (for instance, 1" : 2.8"). The angle *g*, between which the pendulum leaves the one pallet and seizes the other one, measures 20', and *a* = 1° 40' in order to counteract the effect caused by the resistance of air. This escapement is very costly, and is, for this reason, not considered as a practical solution of the problem of the gravity escapement.

DENISON'S three-armed gravity escapement found a more extended adoption. Accompanying figure 3 is the front view of a regulator escapement as seen through the clock. The distance between the wheel centers and suspension centers *l' r'* of the pallets in general amounts to 5 or 6 inches. The raising of the pallets is performed by the three pins, *h*, *j* and *l* near to the wheel center, which stand equidistant from each other. These pins operate under angles of 60° to each other, which must correspond with the impulse angle 2*g* of the pendulum; and since the chord of 60° is equal to the radius, the distance of the pins from the center = 2*g**d*, equal to 0.02*d* to 0.03*d*, according to the magnitude of *g* and *a*;

$$\text{for instance, } r = \frac{d}{40}$$

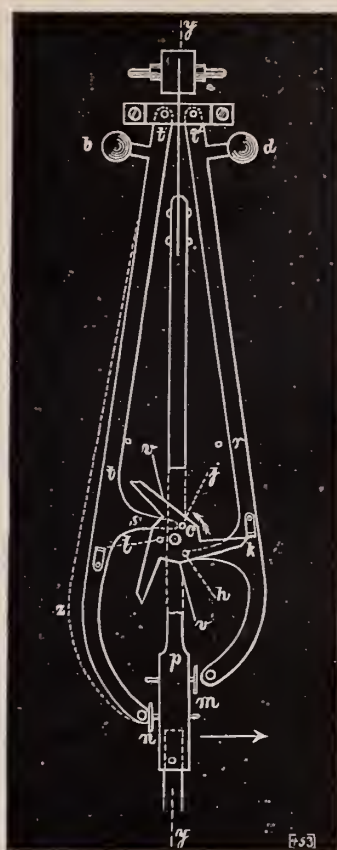

FIG. 3.

2°. This size is established as well by the mathematical formula as by experience. The arc is generally assumed at 2° 15', and in steeple clocks it increases to 2° 30'.

Accompanying figure shows the position of the different parts as soon as the pallet *tt'* has imparted an impulse to the pendulum. It moves to the right side (of the observer) in the direction of the arrow, until the screwhead *m* comes into contact with the round pin at the end of the arm *rr'*. At this moment the pivot *k* permits the arm lying below it to glide off (because *rr'* moves away from it), and the wheel *c* revolves in the direction of the small arrow. The pin *h* of the aforesaid arm hereby strikes against the projection *s* of the pallet *tt'*, and brings the latter into the dotted position *z*. The progressing revolution of the wheel *c* is, however, prevented by the arm of *c*, in the figure to be seen as standing above *s*, which falls upon the part of repose at *l*, so that the arms then assume the position indicated in the figure by the dotted lines *jlh*. At the return motion of the pendulum from left to right *rr'* falls unhindered upon the latter, until this pallet has reached its deepest position, and the screwhead *n* operates upon the pin situated at the end of *tt'*, whereby the same performance is repeated upon this side as indicated.

The pendulum *p* does not come into contact with one of the two pallets until it has not reached one of its two points of repose, and the duration of the impulse depends upon the distance between *z* and the arm *tt*. The intensity of the impulse is established by the weight of these arms and of the weights *b d*.

*v v'* is a fly upon the axis of the scape wheel *c*, the function of which is to weaken the blow upon the end faces of the arms and upon the pins. The location of this fly requires some attention; it must sit very loosely upon the arbor when the friction spring is fastened, otherwise irregularities will occur afterward. The friction itself, therefore, only proceeds from the spring. The flies are each made of a short steel sheet, and then when they are located upon the arbor they are not to be made thinner but rather a little heavier. For ordinary steeple clocks the dimension of each arm is 6 : 1½ inches; for regulators not much beyond ⅞ of a square inch.

The clocks with gravity escapement, generally speaking, require a greater weight than others, for the greater part due to the flies. This difference is less noticeable in larger than in smaller clocks, because the power necessary for the escapement need only be very

(on an average). The length of the cams of wheel *c* is optional; in smaller clocks it is generally made equal to one inch, in steeple clocks 2 inches (with 9 inches distance from the pendulum's point of suspension). The only data of their dimensions can be determined in the following manner: The radius from the wheel center to the escapement part *k*, which receives the stroke from below, must describe no smaller than a right angle with the arm *rr'*, otherwise the latter would endeavor to give way to one side. Again, if the strokes are intended to be uniform, the pivot at *l* of the arm *tt'* must be situated as far below the wheel center as *k* is above it.

The weights *b* and *d* on the arms *tt'* and *rr'* serve for regulating the pendulum arc, which in this escapement (in comparison to others) is made serviceable rather than beyond

small in comparison to the going work in the larger clocks, which is not the case in the smaller ones, although the pendulum is not influenced thereby. For this reason an ordinary small recoil escapement (30 tooth wheel) has in place of the wheel  $c$  been mounted upon the prolonged center staff. In this case, the two interior projections of the arms  $r r'$  and  $t t'$  (for instance,  $s$ ), as well as also the pins upon the wheel  $c$  are omitted.

It is, perhaps, worth while mentioning that a long slot is cut sometimes through the bottom plate and sometimes through the dial of the clock, for the purpose of observing the performance of the escapement.

It can also be seen from accompanying figure how the oscillation of the pendulum is regulated in regulators. In larger clocks, the fork-like joints are mounted upon eccentric nuts, and these parts are always made of brass or aluminum bronze, in order to dispense with the oiling as much as possible.

The introduction of the fly-wheel prevents the limping of the clock no matter how large the clock weight may be, and this advantage of the gravity escapement is of a great significance. This peculiarity became important, especially for the Northumberland equatorial telescope room, where a clock was deemed necessary which should record every beat audibly, without influencing the rate.

The first clock with this Denison gravity escapement was tried in Greenwich, and the watchmaker, Dent, who at first was very much opposed to these escapements, afterward introduced it in the world-renowned Westminster clock.

(To be Continued.)

## The Jewelers' Security Alliance.

President, DAVID C. DODD, JR.

Vice-President, AUGUSTUS K. SLOAN.....Of Carrow, Sloan & Co.

Treasurer, W. C. KIMBALL.....Of H. F. Barrows & Co.

### EXECUTIVE COMMITTEE.

C. G. ALFORD, *Chairman*.....Of C. G. Alford & Co.

C. B. BISHOP.....Of Carrow, Bishop & Co.

HENRY HAYES.....Of Wheeler, Parsons & Hayes.

J. B. BOWDEN.....Of J. B. Bowden & Co.

DAVID UNTERMAYER.....Of Keller & Untermeyer.

E. F. DORRANCE.....Of Dorrance & Brother.

P. O. Box 3277.

HENRY W. HILLER, *Secretary*, Room 2, 170 Broadway, New York.

The April meeting of the Executive Committee of the Jewelers' Security Alliance was held on the 13th. Present—Messrs. Dodd, Sloan, Alford, Bowden, Hayes, Dorrance and Kimball. The Quarterly Report of the Treasurer was received. The Secretary was ordered to issue notices of the Annual Meeting to be held at the office of the Alliance, 170 Broadway, on May 6th, at 3 P. m.

The following named applicants were admitted to membership at the meetings of the Executive Committee held March 25th and April 14th.

Cady & Olmstead, Kansas City, Mo.; McCarty & Hurlburt, Philadelphia; Myers & Finch, St. Paul; Myers & Marble, Poughkeepsie; C. B. Meyer, Yonkers; G. T. C. Rosenthal, Philadelphia; G. W. Russell, Philadelphia; M. A. Ruger & Co., Elmira, N. Y.; J. F. Bartlett, Clinton, Mass.; Calvin S. Ball, Jr., Syracuse; J. D. Hawley, Syracuse; E. E. Hart, Fonda, N. Y.; S. E. Fisher & Co., N. Attleboro; A. Lessor & Son, Syracuse; J. Seymour, Sons & Co., Syracuse; Chas. W. Schiller, Utica; Irving Snell, Little Falls; G. A. Oppel, Little Falls; J. Gomph, Utica; Quintard Bros., Poughkeepsie; A. D. Norton, Gloversville, N. Y.; A. R. Vanderbilt, Amsterdam, N. Y.; King & Eisele, Buffalo; B. H. King, Buffalo; Hammond & Guild, Buffalo; Heintz Bros., Buffalo; Edwin Harris, Geneva, N. Y.; Harrington & Co., Columbus, O.; Michael Harrington, Amsterdam, N. Y.; Hutchison & Huestis, Providence; S. B. Champlin & Son, Providence; R. Collingwood, Elmira, N. Y.; La France & Wise, Elmira, E. Y.; Jos. Linz & Bro., Sherman, Tex; W. C. Lutz,

Buffalo; C. Phillas, Buffalo; T. C. Tanke, Buffalo; T. & E. Dickinson, Buffalo; M. M. Davis, Rome, N. Y.; W. W. Scott, Watertown, N. Y.; Gustave Stritt, Rochester, N. Y.; Mary Walters, Rochester, N. Y.; E. C. Williams, Canandaigo, N. Y.; Wm. H. Weld, Lockport, N. Y.; J. Wendell & Son, Oswego, N. Y.; Chas. W. White, Buffalo; W. F. Parker, Fair Haven, Ct.; Bullard & George, Watertown, N. Y.; Freeman & Crankshaw, Atlanta, Ga.; Robinson & Co., S. Attleboro, Mass.; Wade, Davis & Co., Plainville, Mass.; J. H. Grant, Troy, Penna; Foster Keeping, New York City; J. H. Koch, Savannah, Ga.

## The Roller or Brocot Escapement.

IT IS a singular fact, says CHARLES REQUIER, in the *Revue Chronométrique*, that when looking over the long list of escapements of all kinds and epochs, with which inventive genius has, if not enriched, at least bequeathed to horology, one is struck on perceiving that of more than one hundred different models barely ten have descended to us, and that of these ten four or five may with utility be employed only for clocks or watches, and that of these four two are only used to-day in the manufacture of mantel clocks, and, again, of the last two escapements, the roller escapement is used most.

I have, therefore, thought that it might be of interest to trace up an escapement eminently of French origin, and one which, to-day, is so universally employed.

The roller escapement, the origin of which is to-day ignored by our young horologers, first appeared at the Paris Exposition of 1839, and was at once named for its inventor "Brocot père;" envious watchmakers, however, were not wanting who pretended that the escapement had been invented previously; wherefore it also received the additional name of "roller escapement," by which appellation it is universally known to-day.

Time has done justice; the scoffs of the passionate assailants are no longer heard, and history has even failed to transmit their name; even if Mr. Brocot has, to a certain extent, plagiarized the invention, which is not proven by any means, the honor at least pertains to him of having it developed in a skillful and able manner, and of having rendered it an escapement reliable in all respects, fit to be used for the last forty years in all our clocks of commerce, and it will, in all probability, be destined to be the only escapement employed in the manufacture of clock movements, by reason of the great facility it offers to constructors to obtain good results even with movements of a mediocre construction.

The principles and proportions of the roller escapement were at once enveloped in mystery and disregarded by the majority of watchmakers, except a few workmen better versed than their brethren in the knowledge of geometry.

The most empirical methods and bizarrest procedures were resorted to for tracing this escapement, and it is for us a cheery moment when we recall that period; it was not a rare thing to see two workmen of the same shop hide from each other to insure greater secrecy when about to trace such an escapement, and, after all, neither of them understood its correct principles. This state of things lasted until the theory of the escapement was published by M. CLAUDIUS SAUNIER, in his *Grand Traité d'horlogerie moderne*.

There exists, however, on the subject of the construction of the roller escapement, a widely spread erroneous opinion which has been perpetuated up to our day. Certain watchmakers believe that this escapement must embrace the one-third of the wheel, regardless to the number of teeth or length of pendulum; it is unnecessary to state that this escapement is entirely wrong; the roller escapement is nothing but a variety of recoil escapement, subject to the same laws, and the height of the anchor must be proportioned to the length of the pendulum.

This truth, simple enough to need no demonstration, nevertheless

is so frequently slighted that I have deemed it necessary to recall it here.

Clock movements with this escapement, of a careful construction, will frequently come for repairs, although no attempt at closely regulating can be made with them, although they appear to have no other disturbing cause.

In these movements, in which the length of the pendulum does not exceed 10 centimeters (4 inches), the anchor embraces, as I have said above, the one-third part of the wheel; it will be seen that no manner of regulating is possible with these conditions, in view of the considerable influence exercised by the train on the pendulum, and by replacing this unduly high anchor by a lower one, I have always been able to produce very satisfactory rate with pendulums of 9 or 10 centimeters ( $2\frac{1}{2}$  centimeters = 1 inch).

In spite of its incontestable qualities, the roller escapement possesses one inherent fault. I refer to the disposition of its pallets, the semi-circular shape of which rendered unequal the action of the train on the pendulum, and besides had the very great inconvenience that it was almost impossible to use it for timepieces with a length of pendulum exceeding 50 centimeters (20 inches), since to make it to describe arcs of from 1 to 2 degrees only, with pendulums of from 60 centimeters to 1 meter in length, it became necessary to make the anchor arms extremely long, which considerably impeded the freedom of action, especially when the oil became thick, and this disposition would, therefore, stand in direct contradiction with the principles of modern horology. An excellent improvement has recently been introduced to obviate this inconvenience, by changing the semi-circular form of its pallets for one of an inclined plane in such a manner as to offer an inclined plane to the action of the wheel, analogous to that of the Graham escapement. This disposition is represented in the accompanying cut by the lines from *R* to *H* and from *E* to *N*.

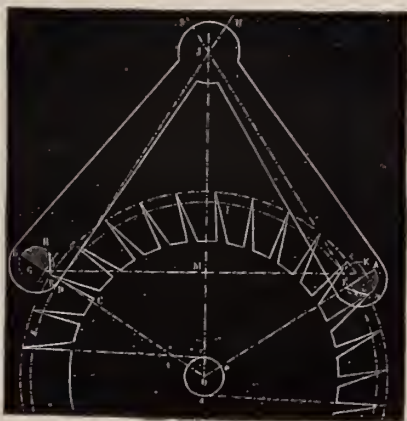

The importance of this transformation will readily be understood; it suffices to give to these planes a more or less large inclination in order to obtain a greater regularity of lifting, and, at desire, a lifting arc more or less considerable without being compelled to modify the proportions of the anchor or to exaggerate the height.

The roller escapement modified in this manner appears to me to be called upon to render renewed services to horology, and to replace the Graham escapement in regulators destined for everyday use, with which it only differs in one point, that of the repose outside of the tangent. This, however, does not constitute its chief defect, and the fact that experiments have been successful in giving a sufficient equality of lifting to this escapement is a veritable advance and an important improvement.

It is still more. A very important effect has been produced in a commercial point of view, since this escapement can supplant the more costly Graham escapement in many cases, and, beside this, the latter becomes more difficult every day by reason of the small number of workmen who are capable to construct it.

And, meanwhile, who is the author of this timely improvement? I do not know and probably there are many others who do not. 1

would not dare to pretend to the honor of having introduced it, although I conceived the necessity for it 25 years ago. I have at once applied it with entire success in movements with seconds pendulum; but at the same epoch, several of my colleagues to whom I had communicated my ideas, assured me that they had always entertained the same opinions and had acted like me; I therefore reiterate the question at the closing of this article: "Who has improved the Brocot escapement?" "Everybody and nobody."

[We translate the above article as an item of news contained in the foreign press; we do not see, however, how this escapement can in any manner pretend to rival, or merely even to approach, the best of all escapements—the Graham. That the escape wheel during the oscillation beyond the angle of lifting makes a small recoil motion, is, perhaps, less open to objections; since even the masters of horology are not yet unanimous on the question whether a small recoil would not improve the Graham escapement. The friction at the point of the escape wheel tooth upon the reposing plane of the pallet in the Graham escapement is not alone more gentle, but the latter is also less subject to the deterioration of the oil and wear, and, beside this, it is preferable as manufactured at present, with loose, movable pallets. *Chacun à son gout*, but as long as the Graham anchor is constructed in correct proportions, and anchor and wheel stand at appropriate distances from each other, we remain quite content with it. It is a pity, however, that the latter stand sometimes too far from each other, whereby the pallets are apt to strike in the side of the tooth. The escape pallet is also sometimes found to have too little bevel].

### Tool for Retouching the Anchor Pallets.

[By MR. H. HAMMARLUND, in *Revue Chronométrique*.]

BY AID of the accompanying figure, the use of the little instrument, destined to render valuable service to watchmakers, will be readily understood.

*P* is a rectangular plate holding between the two projections of a large circular hollow the piece *d d f*, pivoting at *d d* upon the points of two screws. This piece terminates above by an arm *f*, by aid of which may be given any desirable inclination to the surface of *P*.

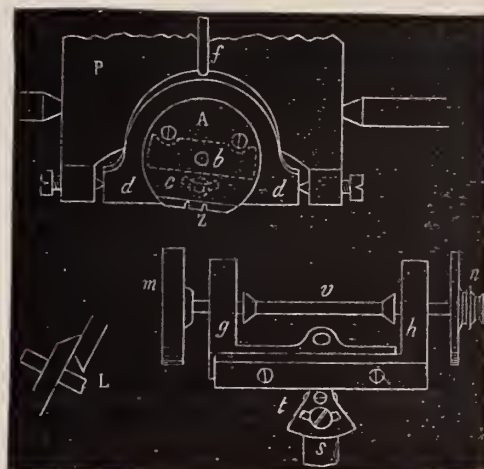

The piece *d d f* accommodates within a large circular sink two equally large discs placed one upon the other, wherefore only one *A*, the upper one, can be seen. These two discs pivot upon a pin *b* which is sunk in in the piece. They are kept apart by a flat upturned spring (visible in the sketch by dotted lines), in such a manner, however, that they may approach each other.

A screw, one end of which is seen at *c*, passes through *d d* in a notch indicated by a dotted line, and then traverses by a round hole the lower disc, and is finally screwed in the upper disc *A*.

This screw having been loosened, the two discs may a certain distance be turned at option to the right or left, and when this position is fixed they are fastened by closing the screw *c*.

The two discs being sufficiently distant the one from the other, the operator introduces at  $z$ , between the two, the anchor or simply the pallet which is to be retouched, and after having established the parallelism of the discs by means of the two screws placed at each side of  $A$ , the whole is kept in a fixed position by closing the screw  $c$ . Next the plate  $P$  is placed between the centers of the turns as shown in the sketch.

The support of the turns is then replaced by the lathe centers which carries a little frame in form of a double angle  $g$  and  $h$ , connected by screws with each other. Between the two angles revolves an axis  $v$  provided at its left end with a small polishing wheel (tortoise shell for garnet and copper for ruby), and at its right end a brass wheel  $n$ , thinner of body but of exactly the same size as the grinding wheel. The small double pulley is fixedly connected with this disc which serves as a point of support of the polishing disc when it is set to run perfectly true, that is, parallel with the arbor.

The rest is easily understood; the contour of the small grinding disc, after having been charged with diamond powder, is placed in contact with the pallet fixed at  $z$  and inclosed between the two discs  $A$ , and the wheel is set in motion by a drill bow placed upon the pulley  $n$ .

REMARKS.—1. The entire contrivance of  $A d d$ , may, according to need, and by the lever  $f$ , be directed perpendicularly to  $P$  or receive a small to-and-fro motion if the face of the pallet is to be rounded off.

2. The two shoulders of the axis  $v$  do not touch the arms of the frame; the axis, under the action of the drill bow, makes a small to-and-fro longitudinal motion which facilitates the work.

3. By the aid of the foot  $t$ , the axis  $v$ , and consequently the grinding disc, may, according to need, be given a perpendicular or an inclined position in relation to the surface  $P$ .

4. When a pallet face is to be polished, the polishing disc  $m$  is to be replaced by another one, the form of which is sketched at  $L$ .

---

### History of Optical Instruments, etc.

THE SCIENCE of optics has at the present day undergone so many important improvements and modifications that a brief sketch may not perhaps be void of interest to our readers.

The history of optical instruments and of optical glass, of course, are contemporaneous, and are comparatively modern. There is little doubt but that the ancients were acquainted with the powers of magnifying by means of glass spheres filled with water; but in order to arrive at the truly scientific portion of optics, we must pass both Roman civilization and the scientific development of the mediæval ages. We may first halt about the beginning of the fourteenth century, at which time, says M. Molineaux, in his *Dioptrique*, glasses were invented to assist persons with weak sight, a conclusion which he has well established by quoting a number of creditable authorities. Brother Jordan de Rivalto, it is said, told his audience in a sermon preached by him in 1305 that spectacles had been discovered about thirty years ago, and had proven themselves to be one of the happiest of inventions. It is believed that one Salviño discovered them, according to a monument which existed in the Cathedral of Florence before the repairs made at the beginning of the seventeenth century.

It is reported that Jean Baptiste Porta, a Neapolitan gentleman, was the first to construct a telescope, according to a passage in his *Natural Magic*, by him printed in 1549. He says: "Provided that you shall properly understand the manner of joining or adjusting the two glasses, that is the concave and the convex, you will see objects equally near and far, and even more distinctly than they appear naturally. By this means we have been able to assist many of our friends who could only see either remote or near objects in a confused manner, to see distinctly in both cases." It seems from this,

however, that the author has reference to adjusting concave and convex glasses, to correct defects of vision rather than to the telescope.

According to Sisturas, in his treatise on the telescope, one Jean Lipperson, or, according to Borel, Lacharie Hansen, presented a telescope to Prince Maurice fifty years afterward, and Borel, who wrote a book on the inventor of the telescope, says that the telescope arose by accident. Some children were playing in the atelier of their father, and told him that when they held in their hands two glasses and placed one before the other at a distance, they saw certain objects much larger than ordinarily, and as if they were quite close, only upside down. The father, struck with this singularity, adjusted two glasses in a frame, securing them in position by the aid of two brass circles, which could be shifted at will. Many persons came from curiosity to see this invention, which, however, rested for a long time untouched. Some workmen living in the same town as Hansen improved on his arrangement. One of these, carefully noting the effect of the light, placed the glasses in a blackened tube; another adopted these precautions, and in addition placed the glasses in tubes sliding within each other.

The first telescopes of long range were constructed by Simon Marius, in Germany, and Galileo, in Italy, and thereby rendered adaptable for astronomical purposes.

Le Rossi says that when Galileo was at Venice he was informed that a species of glass was made in Holland for bringing objects nearer. After reflecting on the reason of this he cut two glasses as well as he could and adjusted them into the ends of an organ pipe, which resulted so well that he exhibited the marvels of his invention on the tower of San Marco immediately afterward. Galileo, after this, devoted himself to perfecting the telescope, and this is the reason that the invention of the telescope is generally accredited to him. It is doubtlessly true that his glass was a prodigious stride in the advancement of science, but nevertheless it was still very imperfect; the object glass being only a single lens, the light of the object was necessarily much decomposed and obscured the latter; devices, therefore, became necessary to remove this defect, and Euler was the first to conceive the possibility and to apply the means of acromatizing. This distinguished philosopher, observing that in the eye the different humors which traverse the luminous rays are so disposed that no diffusion of rays resulted, thought that we could imitate this perfection of nature by combining various media in the glasses; he calculated the curves of glasses between which water had been placed, in order to collect the rays of the different colors into the same focus. The experiments made after his instructions did not quite attain the end desired; still, the problem attracted the attention of scientists, and it did not long remain unsolved.

John Dolland, of London, sought, in 1753, to correct this aberration of refrangibility by combining several glasses of different curves. His first experiments were not very successful, but the result sought was obtained after many experiments by giving the proper curves to object glasses consisting of flint and crown glass. The next difficulty was to obtain flint glass free from blemishes and striæ, which had deflected the rays and disfigured the objects. Many and futile were the attempts made to solve this problem, until at length it was discovered by a watchmaker named Guinand, of Brenets, near Neuchatel, a man who possessed a little chemical or scientific knowledge, and who worked with no other resources than mechanical routine and that precision of execution which is so distinctive and characteristic of his countrymen. His efforts were without results for a long time, and every detail proved an obstacle to him, the laws and the properties of the bodies on which he operated only being discovered by a series of accidents. He succeeded eventually in producing flint glass exempt from striæ, however. M. Bontemps remarks: "The nature of my work had for a long time directed my attention toward the manufacture of flint glass. I had made several experiments, when M. Lerebours put me into communication with one of the sons of M. Guinand, who desired to sell his

secret either in France or England, and which we bought in 1827." General meltings made under the direction of M. Guinand having produced no results, the agreement was dissolved, but it was decided to continue the experiments without excluding M. Guinand, to whom we owe the knowledge of the principles which formed the essential base of the manufacture, and from the first melting made in 1828, under my direction, we produced flint glass, several discs of which were presented to the Academy of Sciences in October, 1828, and from this date the manufacture of flint glass was regularly commenced.

The above about embraces the correct features of optical instruments, and without entering deeply into the manufacture of optical glass, it may be useful to examine superficially what are the qualities required, and what defects are to be avoided in manufacturing it. Although the manufacture of crystals has, on the continent, been carried to a high state of perfection, this material, although apparently of great purity and transparency, and peculiarly adapted for the construction of beautiful vases, is, nevertheless, entirely useless for being ground into lenses. M. Dollond declared in 1828, that for the space of five years he had not been able to discover a disc of flint glass of four and one-half inches diameter, suitable for an object glass. The disc must not alone comply with all the requirements of perfect transparency and hardness; it is also necessary that all of its parts be homogeneous. If it do not comply with the latter requirement, the luminous rays are diverted from the direction they should follow, and, since they do not make the same focus, the image becomes deformed. A glass, to all appearances free from striæ, is composed of several layers of unequal density, and, consequently of unequal refractive powers. It will be seen, therefore, that a glass thus conditioned, is useless for an eye-piece. Now, if a glass almost perfect in appearance is useless for optical purposes, how much greater the difficulty to make a good instrument with one having lines and waves?

It is unnecessary to follow our author into the scientific details of the manufacture of optical glass. The mind of man will recoil at the thought that this glass—this fusion of flint (silica), oxide of lead and carbonate of potash—is able to unfold to him the occult mysteries of nature; when arranged to form a microscope it will reveal to him natural objects of one-two-hundred-thousandth part of an inch in length, or when employed as a telescope it will show him stars, the light of which has taken thousands of years, at the rate of 192,000 miles per second, to reach the earth, according to Herschel and other eminent astronomers.

Truly, there is no other agent employed by man possessing properties equal to glass.

### The Cleaning of Silver and Silver Plated Articles.

THE INNUMERABLE agents employed for the cleaning of silver articles can be divided into two sharply defined groups: 1. Those which cleanse by their chemical effects, and; 2. Those which exert a mechanical—grinding—effect. Among those of the first kind the silversmith possesses several agents which clean the articles quickly and well. They are much employed by the latter, but cannot be used for domestic purposes, since they contain violent poisons. If the piece of silverware to be cleaned is not perfectly smooth, that is, does not possess smooth surfaces, without sharp corners, engravings, etchings, etc., do not by any means use the chamois leather. In its place use a medium hard three or five-rowed brush. For cleaning agent use a mixture of aqua ammonia and chalk, to be employed of the consistency of a thick cream. The brush is first moistened with clean aqua ammonia, the cream is next applied and brushed upon the lustrous parts of the article (avoid the mat places) with gentle pressure, brushing the article in all directions, carefully digging out all the corners, angles and deep parts with the point of the brush, until the brush begins to get dry, and the luster begins to shine out brightly from under the chalk.

Special attention must be paid toward removing the cleaning material out of all deep parts and angles. For mat and gilt places take an ordinary tooth-brush, dip it into clean aqua ammonia, draw it a few times across a piece of ordinary washing soap, and finally dip it slightly into chalk. The above mentioned places are treated in this manner until they show a clean and fresh color. When all spots have disappeared rinse the article in clean warm water until all traces of the chalk and aqua ammonia are removed; with old linen (not cotton) carefully dry all the moisture, and again brush the entire article with the previously used, but now entirely dry, brush, without using chalk. When performing this last brushing be very careful that the brush does not contain too much of the cleaning agent. By drawing it over a table edge it must at most develop a barely visible fine dust. Too much of the agent deteriorates the fine luster.

If the so-called "black luster" is produced, make a buff-stick by glueing a narrow strip of chamois leather upon a sufficiently strong strip of wood, apply a little calcined lampblack (to be had in every drug store) upon the buff side, moisten it with alcohol, and buff over the highly lustered places, whereby they will assume the desirable black luster of polished silver or steel. Silver becomes dingy principally by the sulphuretted hydrogen contained in the air, whereby sulphide of silver is formed, which produces the yellow, brown and black spots. The aqua ammonia dissolves small portions of this sulphide of silver, and causes the spots to disappear. The cleaning agent, chalk, by its grinding effect, produces the luster.

For cleaning mat places of ornaments, proceed in a like manner as specified for the treatment of mat places. Wash them well in hot water with soda and soap and tooth-brush, and finally place them into sawdust for drying.—[*Neueste Erfindungen und Erfahrungen.*

### Competitive Prize for the Excellence of their Compensation in the Different Degrees of Temperature.

THE FOLLOWING is an extract from the report tendered by the director of the Genevan Observatory, Mr. Gautier, to the Horological Society of the city, elucidating the methods to be observed for above purpose:

After stating that the rather large expenses which will necessarily be incurred for the project, and which will be discharged by the co-operation of several scientific societies, Director Gautier gives a short description of the arrangement which is to serve at the same time as hot and cold room for the testing of the chronometers. It consists of five boxes, in which the chronometers are placed, and which are inclosed upon five sides with a metallic casing containing water, which can be sustained at a certain degree of temperature. The apparatus is then enveloped in a woolen covering to protect the former as much as possible against the changes of the external temperature; this whole apparatus is finally enclosed in an oaken box, located in a large room which also contains the Kutter's regulator, to be used for comparing. The hot temperatures are very easily produced by means of a gas flame; the degrees of cold, however, obtained by passing a current of water through an ice box, offered great difficulties. A Kullber regulator was also recommended, but it furnished no satisfactory results.

There are four points which are to be observed for ascertaining the good performance of the chronometer's rate; each one of the latter will be accorded a number of points, the maximum of which, 100, will express absolute perfection, with minimum down to 0, which will be equal to the greatest deviation admissible. The points to be observed are as follows:

1. Mean deviation of the daily rate; limit 1.5 seconds.
2. Mean deviation of the periods of equal temperature; limit 5 seconds.
3. The co-efficient of the mean compensation, which results from the comparison of the chronometer to be tested with a standard timepiece, the rate which of will be established by calculation, while

its deviations corresponding with the temperature will be assumed. The number of the points will be 0 for a co-efficient of 0, and 100 for the highest co-efficient; the other co-efficients will in a corresponding manner be divided between these two limits.

4. Mean deviation of the compensation, ascertained by a comparison of the chronometers with the standard timepiece, basing upon a formula of higher mathematics. The division of the points is done in a manner similar to that of the aforesaid class.

The total of the points obtained from these four points will determine the grade of the chronometer in the final prize award.

All calculations will be made by the attentive and extremely closely observing assistant Gustave Cellérier.

### New Stretching Machine.

THE MOST practical of the several stretching machines with which I am acquainted, says a St. Petersburg correspondent of a German contemporary, is one constructed by the Russian watch-maker, Assenjiew, and here represented in half size.

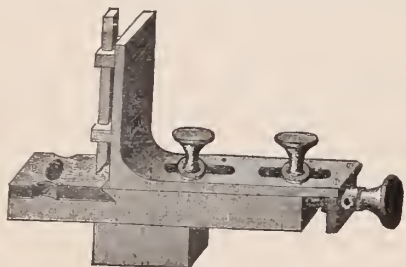

The ordinarily employed machine, with points for placing in the wheel, is beset with many defects. At first it is wanting in the necessary exactness of execution and various other objections irrelevant to mention.

Another, a sort of cylinder stretching machine, a kind of anvil or steel tube consisting of two halves through which passes a pin lengthwise, which is firmly fixed in the lower part while the upper half is movable and revolvable upon it, belabors the wheel not with a punch but with the face of the upper part, while that of the lower serves for placing the wheel upon it. This is a good feature, since no gutter is produced in the ring of the wheel as is the case by machines with punch; but it is open to the objection that gilt wheels are deteriorated thereby in appearance since the graining is destroyed and a certain gloss produced. Again, it will become necessary in the majority of cases to round the wheel upon the engine after having been stretched, since not alone the tooth rim but also the teeth themselves are stretched both in their length and breadth. It is plain that they, therefore, lose their original shape and do not always preserve their just proportions to each other, because some are liable to stretch in length, others in breadth, and the thus produced inequalities cannot always be corrected by the rounding engine. The only instrument which can, in such cases, be used as a remedy is the Ingold fraise.

Again, since these stretching machines cannot be employed for thin wheels which only admit of a careful stretching and little or no rounding; they are, according to my opinion, little suited to the wants of the repairer. They are very appropriate for the adjustment of crude wheels, for which work they are almost exclusively employed, since the depthings are regulated at a time when the wheels are still crude, and, therefore, more easily withstand a forcible stretching and rounding.

The machine in the accompanying cut is preferable to both the above mentioned. Its construction is so very simple that it needs barely any explanation. We will simply mention that the hole in the steel plate which serves for supporting the wheel to be stretched can be as large as 4 or 5 mm., and is calculated for the reception of a somewhat conically turned brass bushing, the perforation of which must be of such a size that the pinion or wheel arbor fits easily into it.

Corresponding to the hole in the steel plate is also the lower part upon which it rests perforated, so that in case of changing the bushing can easily be pushed out from below with an instrument.

By means of the screw situated at the lower end of the machine, the slide, carrying the punch, is moved to and fro, and the latter is thus brought in a correct position to the size of the wheel to be stretched.

I have worked with the several stretching machines above specified, and am, therefore, practically able to recommend the last described one as the most suitable. It cannot be yet found in market, but an ingenious man can make one himself. It is also well suited for teaching the apprentice in the first years of his time the art of filing and turning.

### Coloring Brass.

BRASS, WHEN buried in moist sand, with time assumes a handsome brown color, which may be polished with a drying brush.

A green coating of verdigris (the so-called *patina*) is produced by moistening the surface with diluted acid, and the coating is then permitted to dry of itself.

Brown, of all desired shades, is obtained if the metal is immersed in solutions either of nitrate or chloride of iron, after having been cleaned in a pickle of dilute nitric acid, next cleaned with sand and water and dried. The strength of the solution governs the depth of the color to be produced.

Violet is produced by dipping the metal in a solution of chloride of antimony.

Olive green, if its surface is blackened with a solution of iron and arsenic in muriatic acid, polished with sulphuret of lead and coated hot with a lacquer composed of 1 part varnish, 4 parts turmeric and 1 part gamboge.

Steel gray with a dilute boiling solution of chloride of arsenic and a

Blue one by a careful treatment with strong hyposulphate of soda.

Black is much used for optical instruments, and produced by coating the brass with a solution of platinum or chloride of gold, mixed with nitrate of tin.

The Japanese bronze their brass by boiling it in a solution of sulphate of copper, alum and verdigris.

In the art of bronzing success depends upon various circumstances, such as the temperature of the alloy or of the solution, proportions of the different metals used for the alloy, as well as the quality of the materials. It next depends upon the moment when the articles are to be withdrawn, their drying and a hundred other insignificant details which can only be acquired by practical experience.

### Opening the Regulator.

THE REPAIRER will frequently find, says R. Trumphy, in the *Allg. Journ. d. Uhrm.*, that the regulator of ordinary watches has been opened at some place for the purpose of obtaining an easy friction. Permissible though it be, the observation has unhappily been made that this remedy has been applied with far too little understanding of its merits; the greater portion of the regulators treated in this manner comply just as little with their functions after the action as they did before, because the round part, which is intended to effect the springing, after the opening is generally so thick that its springing is out of the question.

It will appear trivial for many of your readers to engage in so trifling a question, but this insignificance will disappear when we regard the matter somewhat closer. At first, it is not advisable to open the regulator by force—hammering or breaking—because the operator is exposed to the danger of breaking it; and, again, in case of success, an irregular opening is always produced, which, to say the least, is not whatever of a handsome appearance. It is best performed by filing it open with a thin screwhead file. The thereby produced cut is of a far better appearance than an irregular fracture. Should the regulator be so hard that it cannot be filed, it is to be softened until it permits the operation. The blue is to be taken off with diamantine and pegwood. The opening must always be made as nearly as possible at the end which carries the balance spring curbs, since, otherwise, when moving the regulator to one side the rounding would be opened and move too easily, while, when pushed to the other side, it would press together and move too heavily. If the round part is too thick to be springy, it is improved by filing with a cross file a rounding opposite to the incision until a satisfactory springing has been produced. A regulator treated in this manner will always render good services, and the entire work is an operation of a few minutes.



## Workshop Notes.

**CEMENT.**—A cement for meerscham can be made of quicklime mixed to a thick cream with the wite of an egg. This cement will also unite glass or china.

**BENDING GLASS TUBES.**—Fill the tube with finely-sifted sand, close both ends and heat it over the flame of a Bunsen burner. It may thus easily be bent without losing its roundness at the elbow.

**FROSTING POLISHED SILVER.**—Cyanide of potassium, one ounce, dissolved in one-half pint of water. Do not hold the silver in your hands, but use boxwood plyers, and apply the mixture with a brush to the surface.

**SILVER FROM WASTE PRODUCTS.**—The refuse is to be mixed with an equal quantity of wood charcoal, placed in a crucible, and submitted to a bright red heat, and in a short time a silver button will be found at the bottom. Carbonate of soda is another good flux.

**GRINDING TOOLS.**—Mr. F. K. Kaltenthaler says, in answer to a correspondent: "I use a grindstone with a crank for the first grinding of my graving tools, and when nearly ground finish them on an American oilstone. It expedites the work and answers well.

**TO SILVER THE INSIDE OF HOLLOW GLASS.**—Convex mirrors, reflectors, globes, hollow glass vessels, etc., can quickly be silvered with the following amalgam, which becomes fluid at a low heat and adheres to glass: Lead and tin, each two ounces; bismuth, two ounces; mercury, four ounces. Add the mercury to the rest in a melted state, and then move from the fire; mix with an iron rod.

**ORNAMENTAL DESIGNS ON SILVER.**—Select a smooth part of the silver, and sketch on it a monogram or any other design you choose with a sharp lead pencil, then place the article in a gold solution, with the battery in good working order, and in a short time all the parts not sketched with the lead pencil will be covered with a coat of gold. After cleaning the article the black lead is easily removed by the fingers, and a silver ornament disclosed. A gold ornament may be produced by reversing the process.

**CLEANSING POLISHING LEATHERS.**—A correspondent complains that his polishing leathers have shrunk together after washing them as directed by us. This can only have been caused by the use of very hot water; this should be hardly lukewarm. Wash your leathers with ordinary soap which contains much potash, and renew the water as often as necessary until perfectly clean. Then beat soap to froth, and meanwhile mix in a little olive oil, using barely a table-spoonful per leather. Next rinse the leather well and wring it dry, stretch it to all sides, and for the purpose of thoroughly drying hang it in a dust-free place but not near a stove. The oil is for the purpose of making the leather soft and supple, and it need not be feared that the oil will make it smeary. The leathers can also be washed in benzine; they must then be wrung out in a soft linen rag or handkerchief, and rubbed with it until thoroughly dry, otherwise they would shrink together and become hard.

**FUSIBLE CEMENT.**—According to the *Journal Suisse d'horlogerie*, a good, easily fusible cement for fastening glass and porcelain upon metallic surfaces can be prepared as follows: Brass powder in form of a sediment, which has been prepared by laying zinc in a solution of sulphate of copper, is placed into an iron or enameled mortar, and mixed with concentrated sulphuric acid of 1.85. To this paste add 70 parts quicksilver to 20 to 30 or 36 parts brass, according to the hardness desired. When the mixture has been well united, it is carefully rinsed in warm water, in order to expel every trace of acid from it, after which it is left to cool. After a few hours the ready cement will be so hard that tin can be scratched with it. For use it must previously be warmed so that it can be worked in the mortar, whereby it becomes as soft as wax. In this state it is spread out upon the metallic surface, and the object to be fastened (glass or porcelain) is pressed upon it. When the cement has become sufficiently cold it retains with great intensity.

**REMOVAL OF OIL SPOTS FROM MARBLE.**—Oil spots, if not too old, are easily removed from marble by repeatedly covering them with a cream of calcined magnesia and benzine, and brushing off the former after the dissipation of the latter. Another recipe reads as follows: Slaked lime is mixed with a strong soap solution, to the consistency of cream; this is placed upon the oil spot and repeated till the oil spot has disappeared. In place of this mixture another one may be used, consisting of an ox gall, 125 grams of soap-makers' waste lye, and 62.5 grams oil of turpentine, with pipe clay, to the consistency of dough.

**GOLD FILINGS.**—The following process is very useful for working up filings and scraps of gold, gold-plated jewelry, etc. It does not, of course, refine the gold as in the usual process of quartation, but merely destroys the filings of copper, silver, German silver, brass and other metals acted upon by the acid. It will "eat" the solder or brass out of hard-soldered or plated goods, leaving the thin shell of gold. The iron filings are thoroughly separated from the mass by the repeated use of the magnet. All pieces of soft solder and lead should be picked out, and if there is much soft solder in any of the plated articles it should be melted out, and the residue then placed in a shallow glass or china vessel and rather more than covered with good nitric acid. When the bubbles cease to agitate it, the acid should be poured into another cup, and if there is any base metal left, more acid should be added, and the mass stirred occasionally with a strip of glass. When no bubbles appear on adding new acid, that may also be poured off, and the filings washed two or three times, or until perfectly clean, letting them stand a minute or two to settle before pouring off the water. They are then dried and melted. The filings and scraps treated in this manner seldom require more than one melting to make them easily worked and fit for jobbing. There is no skill required, only considerable care in the handling. The silver remaining in the acid may be precipitated in the ordinary manner with common salt. The chloride obtained may be melted into a button, and being pure silver, used as an alloy for other gold.

**STRENGTHENING THE EYESIGHT.**—To a query in the columns of *Deutsche Uhrm. Ztg.*, in which the interrogator complains of weak eyesight, and also for advice from his fellow-craftsmen, a number of answers are given, from which we select the following: "A professor, lately deceased, recommended me in 1867 to use bi-concave No. 30, feebly blue spectacles, and at the same time bathe forehead and temples with a mixture of Ol. balsam 8.0, spir. lavendel 120.0. I have used this remedy diligently, and my eyes have become so strong thereby that I have dispensed with the use of spectacles since 1873, therefore over ten years. Repeated tests of my eyesight with the optometer have resulted in 'No spectacles necessary.'" The next answer recommends spirits of fennel seed, mixed with distilled water, as an excellent lotion for the eyes. "I suffered with weakness of sight about thirty years ago, since which time I still employ it up to to-day with excellent results. There was a certain patent medicine which really possessed excellent curative powers; it was analyzed some time ago, and the result published in a certain paper as follows: Fill a good-sized bottle three-fourths full with absolute alcohol, put into it enough of fennel seed to fairly fill the bottle, cork it, and let it stand for several days in moderate heat, until the alcohol has colored green; now decant the clear fluid and mix it with a little ethereal oil of fennel from the drug store. For use, employ a second bottle, in which pour to one part of this essence five parts of distilled water or filtered river water, and shake the mixture well, by which it changes into a milky fluid. With it moisten a linen cloth and dab the parts around the eyes morning, noon and night. It does not hurt if a little enters the corners of the eye. For continued use it may be taken a little stronger; if it should bite in the commencement, dilute it a little more."

## Trade Gossip.

Chain bracelets are as popular as ever.

The St. Nicholas Hotel is to be demolished.

A new style of jewelry called the "Rosette" is quite fashionable.

A. Seligman, importer of diamonds, will open an office at 26 John street, May 1st.

Cut glass scent bottles are again fashionable, and are sold in many of the principal jewelry stores.

S. Dessau, dealer in diamonds at Paris, France, has opened a branch office at No. 4 Maiden lane.

Rubies, diamonds and sapphires, in alternate settings, are worn in bracelets, hair pins and finger rings.

Mr. J. W. Miller, of Messrs. Miller Bros., has been re-elected president of the Newark Board of Trade.

Joseph Bevan, formerly of Williamsport, Pa., has opened an attractive jewelry store in Winston, N. C.

Joseph Williams, well and favorably known on the road, is now in the employ of Floyd, Pratt & Rounds, Providence.

Bell Bros., of San Antonio, Texas, will shortly move into their new building, which is rapidly approaching completion.

B. I. Price, of Shamoken, Pa., has had a successful auction sale under the management of the eloquent Col. Rutherford.

The Illinois Watch Company, of Springfield, have removed their Chicago office from 71 Washington street to 104 State street.

J. W. J. Pierson, of the Howard Watch and Clock Co., has just returned from a very successful business trip to the Pacific Coast.

C. F. Koester, of the late firm of Reichhelm & Koester, has established himself in the tool and material business at 33 John street.

The E. Howard Watch and Clock Company announce that the new 18 size open face stem wind movement is now ready for delivery.

Open face watches are growing in popularity. They are extensively sold by dealers in high-class goods, especially in the large cities.

Daniel A. Beam, of the Franklin Manufacturing Co., Newark, died suddenly of pneumonia on the night of the 21st ult., at El Paso, Texas.

Circular-bevelled mirrors, with open work brass frames and chains to hang them by, from which fall spiked balls over the glass, are very showy.

Anthony Hessells has opened an office at No. 45 John street for the purpose of conducting a diamond cutting and mounting and manufacturing jewelry business.

Some burglars entered the jewelry store of Dilsheimer Bros., of Philadelphia, and succeeded in carrying off a quantity of rings, plated jewelry, etc., valued at \$2,000.

The firm of Paulus & Raefle, of Philadelphia, has been dissolved by mutual consent, E. Paulus retiring. The business will be continued under the firm name of A. C. Raefle & Co.

The firm of Thomson & Reeser, of Lancaster, Pa., whose auction sale we reported in our April issue, has been succeeded by Wm. Thomson, who will continue the business of the late firm.

The newest fashionable glassware is Webb's Iby. It is English, and very charming in vases, salad or flower bowls. It has an ivory tint, and is ornamented with colored glass flowers in relief.

At a recent meeting of the New York Jewelers' Club, the new constitution and by-laws recommended by the committee were adopted; their annual re-union will probably take place during the last week in June.

Hope & Bro., Knoxville, Tenn., carry an attractive line of rich goods. They contemplate moving into more commodious quarters, where they will be better enabled to meet the demands of an increasing trade.

D. G. Gallet, of Aberdeen, D. T., is said to have one of the neatest jewelry stores in that section of the country. He carries an attractive line of goods, and enjoys the confidence of a large circle of friends.

Harris & Shafer, of Washington, are reported to have consummated arrangements with certain capitalists in that city for the erection of a magnificent store, which they expect to occupy when completed.

The rage for armour continues, and clocks now come in the steel breast plates and shields ready to be placed on a large frame of plush, shield shape, with viziers, spiked balls, battle axes and other warlike surroundings.

Michael H. Cronin, manufacturer of watch cases, doing business in Philadelphia, has been arrested at the instance of A. W. Spear & Son, assayers, of this city, on a charge of making false representations to obtain credit.

T. F. & M. J. Bogle, of White River Junction, Vermont, have been compelled to seek more commodious quarters in consequence of increasing trade. They carry a good line of goods and have quite an extended trade.

Mr. Bittner, formerly manager of the Lancaster Watch Company, has purchased the entire interest of the stockholders of the company, assuming all its obligations. The company will hereafter be known as the Keystone Watch Company.

A young man calling himself Elliott Clifford settled recently in the village of Irvington, and began business as a watchmaker. After receiving several hundred dollars' worth of watches and jewelry needing repairs he disappeared.

James Fricker & Bros.' jewelry store at Americus, Ga., was recently destroyed by fire; loss not ascertained, but is covered by an insurance of \$6,775. The Barlow House and many of the leading business houses in the town were also destroyed.

While some 18,000 movements were awaiting shipment from the Lancaster Watch Company, some burglars broke into the factory and attempted to carry them off. They were discovered by the night watchman and compelled to decamp without their plunder.

A. Pinover & Co. are now carrying a very extensive line of elegant seal rings with raised and sunken initials in incru ted diamond work, and various colored gold. The latter ornamentation is made flush with the stone, so as not to interfere with the wearing of gloves.

Waterman & Lehmann, of this city, call attention to a unique improvement in ear wire and connecting rings for ear pendants recently patented by them. Their improvement insures absolute security while in the ear, does not easily break, and can be readily adjusted.

Mr. Emanuel Untermeyer, well known in the trade, was married April 29 to Miss Julia Michael, of Galveston. After a numerously attended reception and dinner, the happy couple started on their wedding tour. They will have the best wishes of the trade for their future happiness.

The show window of Robert Moore's jewelry store at Williamsport, Pa., was recently smashed in by a couple of daring sneak thieves and a number of watches stolen therefrom. One of the thieves was captured while trying to secrete a pistol with which he had threatened Mr. Moore.

Jacot, Juillerat & Co. have published an excellent little pamphlet entitled "How to Repair Musical Boxes." It is written by a thoroughly practical workman, and conveys a great deal of useful information interesting to every watchmaker. It is sold at the modest price of 25 cents.

Foster & Bailey, the most extensive manufacturers of gold front goods in the country, have recently patented a unique device for securing pin tongues in lace pins, etc. It is a positive safeguard against accidental detachment, and is highly commended by all who have handled their goods.

Two youths, one in the employ of William Reiman, and the other employed by Mr. Eichberg, dealer in watches, etc., suddenly disappeared recently with a quantity of goods belonging to their employers. They sailed for Europe, but were intercepted at Queenstown and returned to this country.

For the Swiss watchmaker, M. G. A. Leschot, who died on February 4, the claim has been advanced that he was the first to suggest in modern days the use of carbonads (fragments of black diamonds) at the lower edge of cylindrical drills for piercing rock in the process of well boring, tunneling, etc.

We are pained to announce the death of F. A. White, son of N. H. White of this city, who died of consumption of the throat April 20th, in the 23d year of his age. The deceased was confined to his bed about a month previous to his death, but had been a sufferer for over two years. The deceased was associated with his father in business, and was a young man of excellent business habits and good promise.

George R. Howe, of the firm of Carter, Sloan & Co., has been elected vice-president of the Essex Art Association of Newark, in which some forty employees of the firm are receiving art instruction. This is an admirable institution and the goods of the firm are already showing the good effects of its works.

Mr. John C. Warnock, for fourteen years the leading representative on the road for the Meriden Britannia Company, died April 8. He was a man of rare integrity, truth and affability, manifesting always a true manliness of character and disposition rarely found. All who knew him will mourn his loss.

Messrs. Oppenheimer Bros. & Veith, of this city, have bought the entire stock of the following grades of Lancaster movements known as New Era, West End, Fulton, Franklin and Keystone; key and stem winding. These goods are offered at a price that will compel the attention of buyers. Price list sent on application.

Messrs. L. Straus & Sons offer an unusual display of Bisque figures, embracing a large variety of subjects artistic in design and beautifully executed. This class of goods has been quite successful with all dealers who keep a diversified stock. They are suitable for the requirements of the trade in all sections of the city.

At the temples of Kroto, Japan, is the great bell cast in 1633. It is 18 feet high, 9 feet in diameter, and  $9\frac{1}{2}$  inches thick. Its weight is nearly 74 tons. About 1,500 pounds of gold are said to have been incorporated in the composition. Its tone is magnificent. When struck with the open hand its sound can be heard at a distance of a hundred yards.

The Northwestern Watch Case Company announce that they are about to commence the manufacture of the Climax Reversible Watch Case in gold. Hitherto the company has confined its efforts exclusively to the production of silver cases, but a growing demand for this style of case in gold of standard quality prompts them to commence their manufacture at once.

Just at present the popular craze in the trade appears to be for dust proof watch cases, and new devices are being constantly offered to manufacturers. The disease is taking a serious form, and must sooner or later result in brain fever or a law suit. In the latter case some of the inventors who are striving to see how closely they can drive to a valid patent, will be apt to get hurt.

An international exhibition of metal work is to be held next year at Nuremberg. It will be held in the new museum building, and will contain specimens of the art of the silversmith and the worker in brass and copper, together with the machinery and appliances used in the making of jewelry and art metal work. The exhibition will be open from the middle of June to the end of September.

A meeting of the Illinois Retail Jewelers' Association is alleged to have taken place in the parlors of the Leland House, Springfield, April 2, and is said to have resulted in the election of Mr. Noterman, of Hillsboro, President; G. Anderson, of Taylorville, Vice-President, and J. E. Boynton, of Jerseyville, Secretary and Treasurer. The number of members present is not stated, but it is fair to presume that there were others than the officers there.

The many friends of the late firm of Magnin, Gueden & Co., for many years one of the leading importing houses in this city, will be glad to learn that Mr. David J. Magnin, of the old house, has established himself as a commission merchant at No. 13 Rue Reicher, Paris, where he will be happy to see his old friends in the trade, and promises to make their stay in Paris as pleasant as possible. We wish our good friend all the success imaginable in his new enterprise.

B. H. Stieff, of Nashville, Tenn., is generally regarded by traveling men as one of the most courteous and kindly disposed gentlemen with whom they have dealings. It is a pleasure to be refused by him and ecstasy to take his order. As a consequence of his genial manners and pleasant recognition of them, the travelers take particular pains to see that he has the first sight of all novelties and the pick of all their goods. It pays to be polite even to commercial travelers.

An assessment of five per cent. of their claims has been levied upon the creditors of G. S. Rothschild, of Memphis, who was recently sentenced to three years' imprisonment in the penitentiary, and who has appealed to the Supreme Court of Tennessee. The fund raised is to be used in continuing the prosecution, and also for prosecuting proceedings under an injunction obtained against persons suspected of secreting Rothschild's goods. The committee representing the creditors in this matter are entitled to much credit for the energy with which they have conducted this case in the interests of the trade in general.

Mr. S. W. Hale, of this city, an old and well known manufacturer of jewelry, who has been identified with the trade from boyhood, has, through unfortunate investments, been compelled to make an assignment. A misfortune of this kind befalling a business man is a terrible shock at best, but coming, as in this instance, when the unfortunate person has reached "the sere and yellow leaf" of life it is doubly distressing. Mr. Hale will receive the sympathy of all who know him.

A clock at Brussels has been going for eight months and has not required to be wound up since it was first set going. In fact, the sun does the winding of this timepiece. A shaft exposed to the sun causes an up-draught of air, which sets a fan in motion. The fan actuates mechanism which raises the weight of the clock until it reaches the top, and then puts on a brake on the fan until the weight has gone down a little, when the fan is again liberated and proceeds to act as before.

A well-dressed man, who refused to give his name, recently called on Inspector Byrnes, to whom he handed a hunting case gold watch. He said that he lunched in Nash & Crook's restaurant, in Park Row, at 12 o'clock, and when he returned to his office he put his hand in the outside pocket of his overcoat, and found the watch in it. The watch is elaborately engraved, of the Springfield (Ill.) Watch Company's make, case No. 13,914; movement No. 605,563. It is now locked up in the Detective Bureau awaiting a claimant.

The American Watch Tool Company, makers of the celebrated Whitcomb lathe, have, in consequence of increasing business in the West and Northwest, opened a branch office at 31 Washington street, Chicago, where a full line of lathes, attachments and foot wheels may be found. A correspondent, writing of the success of these lathes in the West, says: "We are having quite a run on Whitcomb lathes. They are selling faster than we can supply them. Every purchaser speaks of them in the highest terms of praise.

Announcement is made of the dissolution of the firm of Hall, Nicol & Granbery, and McCarty & Hasberg, and the organization of the McCarty & Hall Trading Company (limited), with the following officers: President, J. Barclay McCarty, of the late firm of McCarty & Hasberg; Treasurers, Bolton Hall and Benjamin Nicol, treasurers of the late firm of Hall, Nicol & Granbery. The business formerly conducted by Hall, Nicol & Granbery will be continued at 20 and 22 John street under the firm name of D. W. Granbery & Co.

Although the headquarters of the manufacture of articles of amber and meerschaum must be considered to be Vienna, this industry, which has risen from small dimensions to enormous proportions, is pretty well distributed among several of the large cities of the Austrian Empire. The amber is imported from Dantzic, and the meerschaum is brought in blocks from Asia Minor, where the meerschaum is quarried. Imitation meerschaum, introduced into the market of late years, is made of the chips of the genuine meerschaum.

"In connection with the Waltham Watch Company, it may be stated that when the proprietors of the *Age* desired to present Mr. G. E. Morrison (the explorer of New Guinea) with a reliable chronometer, acting upon the advice of Mr. R. L. Ellery, the government astronomer, two Waltham watches were, however, procured for Mr. Morrison instead. These were kept at the Melbourne Observatory for a fortnight and thoroughly and carefully tested, and were pronounced by Mr. Ellery at the end of that time to be *better* suited for Mr. Morrison's requirements than any chronometer."—*Melbourne Age*.

Last month we had occasion to allude to the remarkable "finds" of diamonds that had suddenly been reported from different sections of the country for the benefit of the credulous who have more capital than brains. This month we have to record another "find," only this latest diamond is an alleged ruby. It was found in Alabama, and weighed ten ounces in the rough. It was found in the hills of Coosa. Coosa is a good name, and ought to sell the stone for a big price. It is not every country that can spew out ten-ounce rubies, and when they are found they should be appreciated. We would not advise the discoverer of this precious stone to go into any extravagancies on account of his find—do not take to fast horses or wine, nor buy a newspaper—travel on in the even tenor of your ways and await further developments from the Coosa hills. One ruby is not much—wait till you get a bushel or two and then spring them on the market suddenly. By this means you will get up a boom in rubies and they will go off like hot cakes. Just now this is the silly season for rubies, and it ought to be worked for all it is worth.

John A. McCloy, Secretary of the New England Manufacturing Jewelers' Association, was married April 23, at Providence, to Miss Lizzie C. Chase. After the ceremony a reception was held by the bride and groom, which was attended by numerous representatives of the trade in Providence and New York. The happy couple sailed for Europe, accompanied by the well wishes of hosts of friends. Last year Mr. McCloy went to Europe alone, and was terribly seasick both going and returning; he has had the foresight this time to take a companion with him, probably under the impression that his new wife will divide the sickness with him.

The jewelry store of C. E. Hall, of Lebanon, Ohio, was entered by burglars recently and robbed of money and jewelry to the value of \$1,600. By some means the thieves knew the combination of the office safe, and took the money from it without difficulty, leaving it safely locked after them. They then attacked the stock safe, breaking the dial and drilling it in two places, but failing to obtain access. From the skill displayed in this and other recent robberies of jewelry, and the care with which valuable goods are selected, suspicion is excited that there are some persons well informed as to the trade who are behind these burglars directing their operations.

Two young men in the employ of General Ford, the well-known jeweler of New Haven, have been systematically robbing their employer for some months. One of them, named Charles Spaulding, fled to New York, where he was arrested by one of Pinkerton's detectives, and taken to the Seldon House, New Haven. In the course of the evening Spaulding shot himself, inflicting five distinct wounds, and on the following morning died in great agony. The deceased belonged to a popular club in New Haven, but was regarded as fast. W. A. Dart, an accomplice, was also arrested, and charges were made against him. The amount of goods stolen by the accused parties is estimated at \$2,000.

We are sorry to say that no new watch company was started last month, nor has the market been overstocked with the productions of those that were started in the previous two months. Still there are numerous inventors around with model watches looking for capitalists to take hold of them, and we hope to be able to announce a new crop of watch companies in our next issue. The latest scheme is a proposed company whose stock shall be held exclusively by dealers, and, in consideration of liberal subscriptions, the dealers are all to have the exclusive privilege of selling the movement produced, while the jewelry they want will be sold them on time and eternity given them to pay for it. This scheme ought to be popular.

Oculists are well aware that there is a very intimate connection between the human eyes. M. M. Knies and Horner have demonstrated a direct communication between the two retinae, by way of the optic nerve and chiasm, by means of injections of Prussian blue in dead bodies. Recently Pfluger corroborated these assertions by making injections in dogs with a few drops of a saturated solution of fluorescein. This fluid was forced into the optic nerve so that it passed not only into the sub-arachnoid but also into the subdural space. Two minutes after the injection both eyes showed a fluorescence of the retina, which persisted for several weeks. A small quantity injected into the orbital cellular tissue gave no result.

Mr. W. H. Thorpe announces that the fourth annual meeting of the Wisconsin Retail Jewelers' Protective Association will be held at Madison, May 7. It is claimed that "the association has done a great deal to correct the evils that existed in the jewelry trade prior to its organization—such as the promiscuous circulation of illustrated catalogues, and although the catalogue nuisance is not abated, those houses who issue them are much more careful to send them to the legitimate trade only, and are also more careful in selecting their customers, so that most of the goods in our line that are sold to the outside trade are sold by such jobbers as are not recognized by the retail jewelry trade." A good attendance is urged.

A man known as William Malone, alias Quinn, was recently arrested in Minneapolis by Pinkerton's detectives, acting under instructions from the Jewelers' Security Alliance, charged with being implicated in several large robberies of jewelry stores. In February, 1883, the store of E. Vail & Son, of Laporte, Ind., was entered by burglars and robbed of goods valued at \$15,000. Three men were convicted and sent to state prison for this job, but the detectives were confident that the chief of the gang was still at large. Subsequent robberies convinced them that he was still plying his trade, and they finally located him in Chicago in the person of Malone. He was seen to take a train for Minneapolis, and on his arrival in that city he was arrested. He was turned over to the Laporte authorities, and will be tried for the Vail robbery.

Roswell W. Keene, of No. 10 Wall street, has filed with the Secretary of State a certificate of incorporation of the Diamond Company (limited) for the purpose, as set forth in the prospectus, of "mining diamonds and other precious stones, the cutting and working, purchase and sale, the selling and loaning of the same for the purpose of gain and profit and the cultivation of art." The capital stock of the company is placed at \$2,000,000, every dollar of which has yet to be subscribed. The other incorporators are Eunice Keene and Marion E. Keene, of Brooklyn, Henry J. Turner and Sarah C. Turner. Roswell W. Keene says he spent a year in the South Africa diamond fields, and is convinced that money can be easily made by buying diamonds there and selling them here.

All the large cities are filled with various adventurers who trade upon the reputations established by honorable merchants. Recently our attention was called to a circular and price list sent out by some of these swindlers, who used the name of one of the best known dealers in the trade with the change simply of the initials. These lists were sent out promiscuously and some persons were foolish enough to forward money for some of the goods advertised at such "low rates for cash." Of course, they never received the goods or heard of their money. While we have little sympathy for persons who are verdant enough to be caught with such clap-trap nonsense, we nevertheless object to having swindlers loose in the community. The government should prosecute them for using the mails for fraudulent purposes, and if victims will report their losses to the postmaster he will do all in his power to capture the scoundrels.

We have received the catalogue issued by the Pencil and Brush Club of Waltham, on the occasion of a loan exhibition held under their auspices last month. It is noticeable for the many specimens of art work—oil paintings, carving, etc.—exhibited by the employees of the Waltham Watch Company. Some of these are works of much pretension, admirably conceived and artistically executed. They do credit to the artists who executed them, and would attract the attention of the cultivated in any exhibition. This is another proof of the fact so often pointed out by us, that there is a vast amount of artistic skill in the jewelry trade that only needs proper encouragement to shine forth in works that will advance the standard of the trade and redound greatly to its credit. Profit, too, will be found in encouraging it, for it will lead to improvements in designs and ornamentation, and in new styles and patterns of original conception, and relieve the trade of the necessity of drawing on European skill for choice work. The importance of encouraging art study among employees in the jewelry trade is being appreciated by some eminent firms, and plans for giving effect to their ideas on the subject are now being discussed. We shall soon have occasion to refer to them at length.

Canada is a very large country; it has a great many people to the thousand, and among them are the usual sprinkling of jewelers, large and small. Certain of these dealers in Montreal have recently been engaged in a lively fight, and, to read their advertisements in their local papers, they evidently imagine that the watch trade of the world is dependent upon them. Perhaps, however, this tempest in a tea pot is the result of the efforts of a representative of the "peacemaker" watch movement to introduce his goods. At any rate, the local dealers in several places seem to be by the ears and are advertising standard movements at very low rates. First, Bragg advertises that he desires to close out his stock of watches and so offers them "below cost." Then next day a rival announces that he has received an invoice of these same standard movements "fresh from the factory," and is enabled to offer them cheaper than anybody else. Next day a third chips in with his little advertisement discounting all the others. Then along comes the "peacemaker" and says to number one: "Why all this fuss, this cutting of prices and this unseemly rivalry? Let all these old movements go and take the 'peacemaker'; it will bring you peace of mind, contentment, happiness and many shekels. You alone of all the dealers in this city shall have the exclusive privilege of selling the 'peacemaker' in this locality; all the profit shall be yours, for there shall be none to compete." And dealer number one is caught with this chaff, takes a supply of "peacemakers" and is happy. What is his surprise next morning to find, conspicuously displayed beside his advertisement in the daily paper, the announcement of half a dozen of his competitors offering the "peacemaker" movement for sale at cut rates. He then realizes in a most forcible manner that this is a cruel and wicked world. And this is the way the "exclusive privilege" racket is being worked in Canada and some other localities. Moral—buy your goods of responsible makers, sell them for a fair profit, and avoid all undignified and unseemly contention with your legitimate competitors.



# THE JEWELERS' CIRCULAR AND HOROLOGICAL REVIEW

*The recognized organ of the Trade, and the official representative of the Jewelers' League.*

A Monthly Journal devoted to the interests of Watchmakers, Jewelers, Silversmiths, Electro-plate Manufacturers, and those engaged in the kindred branches of art industry.

**SUBSCRIPTION:**

To All Parts of the United States and Canada,  
**\$2.00 Per Annum; Postage paid.**

To Great Britain, France, Switzerland, Germany, the West Indies, Mexico, the Republics of South America, and Australia, \$3.00 per annum. Postage paid.

*All communications should be addressed to D. H. HOPKINSON, 42 Nassau Street, New York. Advertising rates made known on application.*

**Gambling in Business.**

THE BESETTING sin of the average business man is envy of the prosperity of his neighbor. He sees a few fortunate men enjoying the possession of great wealth and he envies their position. He becomes ambitious to acquire sudden riches; his ordinary business does not afford him the opportunity for accomplishing this end, and so he is tempted into speculation of one kind or another. Usually he seeks the advice of some acquaintance, who gives him "points" relative to certain stocks or mining property, or advises him how to speculate in the produce market. Following these suggestions he withdraws capital from his legitimate business where it is needed, to invest it in speculation—gambling is the better word—buying and selling values of which he has not possession and which he would not know what to do with if he had. There is a certain class of men known as brokers who follow speculation as a business, and it is a part of their business to tempt unsophisticated outsiders to put their money into the whirlpool of gambling investments. It is estimated that there are in Wall street alone fourteen hundred of these speculators, living extravagantly, who must be supported by the outside public. They are not satisfied with a modest annual income, but spend as much money in a single year as would be regarded by many a man as a modest competence. Every other city of importance is cursed with a proportionate number of gamblers of this class, who are recognized as brokers in some special line—stocks, cotton, produce, etc.—but who, in reality, have "no visible means of support." It would be a good thing for the country if the laws relative to vagrants could be applied in their cases. But, while in reality their business is gambling in recognized values, they are regarded as men having a legitimate occupation, and instead of being prosecuted alike with faro dealers and policy players, they are looked upon with a certain degree of reverence as men whose operations regulate the markets of the world, and are regarded with envy by many who seek to imitate them.

Buying and selling anything of value is honorable and legitimate, but betting upon what the price of certain things of value will be on a given date is not legitimate business. This is about what the operations on our various exchanges amounts to: A, who thinks the price of wheat is going down, says to B, "I'll sell you 10,000 bushels to be delivered in thirty days for \$1 a bushel." B, who thinks wheat is going up, accepts the offer. At the end of the specified time they settle according to the market price of wheat on that day, the one who has guessed wrong as to the price paying the other the difference. Neither owns a bushel of wheat nor does either want it. Their business is simply to lay wagers on events to transpire in the future. Numerous transactions of this nature tend to fix the price of wheat throughout the country. Similar transactions at the petroleum exchange, the cotton and produce exchanges, mining exchange, stock exchange and other special marts, fix the prices of the commodities to which they refer. It therefore happens that the prices of our various products, stocks, bonds and other values are really fixed by gamblers who do not own them, but simply speculate in them. Occasionally a man makes a large fortune very suddenly in such transactions, so does a fortunate gambler occasionally "break the bank" and reap a rich harvest. But where one stock operator or gambler is successful, thousands are losers; the temptation, however, is so strong and the excitement so great, that few who have once indulged in either of these pursuits is content to quit until he is financially if not morally and physically wrecked. It is speculation of this character—buying and selling what neither party to the transaction owns or has an interest in—that keeps the general business of the country in a foment and unsettled; the fictitious operations of the exchanges extend to legitimate enterprises, affect values employed therein and keep everybody in a state of uncertainty. Speculation is the greatest evil legitimate business has to contend with.

Notwithstanding the great number of victims that have been sacrificed to this spirit of speculation, there is never a lack of either men or material with which to feed its insatiable appetite. Men who are engaged in legitimate business are constantly tempted to take "a flyer" in stocks, in petroleum, in produce or something that is governed by speculation. A few hundred dollars put into the hands of a broker makes one a speculator, and his profits or losses depend upon the fluctuation in prices as determined by the speculators. The usual outcome of such a venture is a demand from the broker for "more margin," which the victim continues to comply with till he can go no further and sacrifices all he has put in. It may take months or only a few days to "clean him out," but in nine hundred and ninety-nine cases in a thousand this is the final result. Speculation has been the most fruitful cause known of the bankruptcy of legitimate business enterprises. In almost every account of failures we read that they were induced by "unfortunate outside investments"—in other words, outside speculations had absorbed the capital that belonged to the legitimate business, and the creditors of the bankrupt had to stand the loss. Some instances of

failures in the jewelry trade resulting from this cause impel us to speak strongly on the subject. No man who has bought goods on credit has a moral right to speculate. His creditors trust him believing him to be engaged in a legitimate business enterprise, the general nature of which they fully understand and the hazards of which they are willing to share with their debtor. They do not expect, however, that when the debtor sells their goods he will risk the proceeds in betting on horse races, "fighting the tiger," speculating in fictitious values or indulging in other immoral practices. They certainly would not trust him knowing him to be addicted to such practices, and to indulge them is little better than swindling. No man engaged in legitimate business has a right to engage in speculation of any kind so long as he owes a dollar. When his debts are all paid he has a right to do what he pleases with his money, but so long as he owes anything his creditors have rights that he cannot honorably lose sight of, and they certainly will not approve of outside speculations any sooner than they will of gambling. The great misfortune afflicting our people is that they are not satisfied with a modest competence; they want to be exceedingly wealthy and to acquire riches speedily. They are not content to plod along in honest business enterprises, making a living and laying by something each year, thankful for the opportunity given them of providing comfortably for their families; they all want to be millionaires and have a good time. Exceeding riches are given to but few; the great majority must be content with little, and blessed is he who is satisfied with what he has. Legitimate business honestly conducted will give millions of men an honorable livelihood where questionable speculation makes one man rich. Moral—stick to your business and you won't get your fingers burnt in outside speculation.

---

### Buyers Abroad.

AMERICAN IMPORTERS of diamonds are the largest buyers of precious stones that visit the European market. They buy liberally and of the choicest products of the mines. Our importers send their buyers abroad every year, and there is a popular idea that these buyers have a most enjoyable time wandering through Europe in search of gems both rich and rare. Such, however, is far from being the case. The competition among buyers is very great, and each one has to keep his eyes remarkably wide open lest the desirable stones are secured by his rivals. The diamond market abroad is controlled by a syndicate that has representatives in Paris, London and Amsterdam. There is really no governing price for diamonds in the hands of the syndicate, but the price depends largely upon the number of buyers in the market, and the character of the individual negotiating. Especially is this true of Paris, where a vast amount of time is consumed in every transaction. Indeed, we have heard buyers say that after they had made their selections in Paris they could not get the prices fixed till just as they were ready to depart, and that they had to watch the transaction very closely till the goods were actually delivered. Diamonds are put up in parcels which contain good, bad and indifferent stones, the undesirable ones predominating. When a buyer sees some stones he would like, he must buy the whole parcel or none. The representatives of the syndicate that controls both the African and Brazilian mines, are the keenest experts to be found and the sharpest dealers. They know every trick in the trade and it requires much skill and ingenuity to keep pace with them. They study the demand very carefully and prices are made to correspond. Last year it happened that sixty buyers were in London simultaneously and forthwith the price of diamonds went up. The Americans, however, being the largest buyers, are sought out by the dealers and given the pick of the stock in hand. The price of diamonds has been steadily advancing of late. When, under the stimulus of an active demand prices have advanced, they have remained at the high figure even after the

best parcels had been selected. It has happened that our importers who have bought at a favorable time, have subsequently sent their goods back and realized a handsome profit when the demand was so active as to send prices up abnormally high. More uncut diamonds are being brought to this country every year, for the reason that several houses are now prepared to do their own cutting. Amsterdam formerly had almost a monopoly of diamond cutting, but recently better work has been done here than the Amsterdam workmen ever did. As our tariff favors uncut stones, there is a profit in bringing them here in the rough and cutting them as they are wanted. It requires great skill to buy uncut stones, for it is almost impossible to estimate their value in the rough or to determine how they can advantageously be worked up. Our buyers have no sinecure when they are abroad, for they are brought in contact with the best experts and sharpest merchants in the world. If they are successful, as they have been thus far, in keeping our market supplied with the choicest gems the mines afford, it is due to their pertinacity, good judgment and special tact.

---

### Peculiarities of Buyers.

BUYERS ALL have their peculiarities, and when they come to New York, it is the business of the jobbers to "size them up," and humor their peculiarities while selling them the largest amount of goods possible. There is the vacillating buyer who wants to replenish the stock of his little store out in Squedunck, but don't quite know what he ought to buy. His market is a slow one, and he is in doubt as to what will best call forth the shekels from the pockets of his close-fisted customers. Last year he had quite a run on big silver watches and wedding rings, but is fearful that the "boys" have got all the watches and all the wives they want, so that he can't count on them for this year's trade. The lumber business wasn't very profitable last winter, and the young men, he is afraid, won't feel like buying bracelets and pins for their sweethearts; the old folks will want a few spectacles, but they run mostly to steel bows, and eye glasses are not fashionable in his locality. What to buy is with him a weighty problem, that can only be solved by visiting all the manufacturers, overhauling all their goods and still being doubtful as to the few he finally selects. Such a buyer does not appreciate novelties, wants standard goods, and so the jobbers exert themselves to work off old stock on him. All the way home he is in doubt whether he can find a customer for that  $\frac{1}{2}$  dozen of fancy bracelets he bought and that cost him \$50 a dozen. While in the city he was fearful of being imposed upon; he had read of the tricks of New York sharpers, and looked upon every person he met as a "bunco steerer" or a "capper" for a gambling house. He would deal only with the old established firms lest the younger houses should impose upon him. He spent a week going the rounds before placing his little order, and afterwards was sure he could have done better somewhere else. This is not a profitable customer, for he consumes too much time and gives too much trouble by his vacillating indecision.

Then there is the nervous, impulsive buyer who is "business" all through. He comes in with a bustle and rush, is in a great hurry to get away, must catch a train and conveys the impression that the business of the universe is dependent upon his movements. "Show me something new" is his cry as he rushes from house to house, and he will not waste time looking at things he has seen before. He buys sparingly, but finds out everything so he can send orders as he wants more goods. Wherever he goes, he is lively, brisk, sharp and always in a hurry, so that when he departs he leaves an impression that a small-sized cyclone has passed through the store. This buyer is a desirable customer, gives little trouble, pays his paper promptly at maturity and is counted as good for all he will buy. His greatest fault is that he doesn't stop long enough to let any one get acquainted with him.

The pompous, self-sufficient, hypercritical buyer is one that salesmen do not care to be brought in contact with. Indeed, he always asks for the head of the firm, and doesn't feel quite satisfied unless he is waited upon by that personage. His principal business seems to be to impress upon everyone a due sense of his importance, the buying of goods being a secondary consideration. The fact that he is an alderman in the flourishing village of Quohog he conceives to be something worthy of national recognition, and he feels quite flattered if his political influence is alluded to. He knows all about the jewelry business; no one can teach him anything; the goods shown are tolerable but not up to his standard; if he were a manufacturer he would make goods that were attractive—something artistic and elegant; he questions the quality and workmanship of everything, objecting to this ornamentation and to that decoration, finding fault with whatever is shown him, and wondering if he hadn't better look further before ordering. The great "I" and the little "u" figure conspicuously in his conversation, and he wants everybody to understand that he is conferring a great favor on the firm by accepting credit from it. He expects to be invited out to lunch, to have a bottle of champagne opened in his honor, and to be regaled with a good cigar after it—toothpicks he will provide himself. Such a buyer is a standing subject for bad jokes among salesmen, and if they ever see an opportunity for puncturing his pomposity they are very sure to avail themselves of it. He is, notwithstanding his manners, a very good customer to have on one's books; he buys with a fair degree of liberality, and his self-love impels him to take care of his paper with commendable promptitude.

Then there is the hail-fellow-well-met buyer. He is always jolly and good-natured, is well posted on sporting events and news of the day, rejoices in a good joke, laughs appreciatively at bad puns, is a good feeder, enjoys a good cigar, and if you ask him out to lunch will not be happy unless he is permitted to spend as much as you do. He generally has good taste and buys judiciously, making his selections of goods between stories and jokes, takes suggestions kindly, asks advice unhesitatingly, buys what he wants and no more, is up to all the tricks of the trade and can't be caught napping; he is a man of good business principles, abhors meanness, has some fixed prejudices regarding men and things which he expresses vigorously. He buys early in the day so he can go to Coney Island in the afternoon or the theatre in the evening, but his motto is "business before pleasure;" he has come for business but don't object to the pleasure. Fall in with his ways and he is a good customer, but his ways do not savor of the Sunday school in the least; he is of the world worldly, hating cant and hypocrisy, and nothing pleases him better than to spend a jolly evening with half a dozen jolly fellows, not in debauchery, but in having a pleasant social time. Salesmen always like these customers, and the head of the firm seldom has occasion to regret courtesies shown them, for they are usually good business men and take care of their creditors.

The very precise buyer, who knows just what he wants before he leaves home, and has his memorandums all made out, buys promptly and gets through quickly, is a desirable customer. He is all business and does not waste time doing it. He is well posted as to manufacturers and jobbers, and knows just where to go to get what he wants. It is useless to urge him to buy what he doesn't want, for he will put you aside in an emphatic but not impolite manner. He doesn't know what a joke is, and one would as soon think of fooling with the business end of a wasp as to play a practical joke on him. He wants every courtesy or advantage that other buyers have, but no favors. He will decline the lunch tendered him, preferring to be under obligations to no one, paying his way and being wholly independent. He is proud of the fact that he pays his bills promptly and is respected in his own community. The only objection to him is that he is too intent on getting rich; he is "business" all through day and night, and does not know what it is to have a holiday, and never gives his mind a rest. He is one of the kind that will be old at fifty and either rich or bankrupt before that time.

It takes all kinds of men to make up the jewelry trade as well as the world, and the hasty sketch we have given of a few types is only an illustration of the various characters to be met in Maiden Lane daily. We don't know that there is any particular moral to be drawn from this glimpse at the peculiarities of buyers, but will conclude by advising all who desire to purchase goods to first understand their market, learn what they can sell to advantage, then buy it at the best market rates.

---

### Commercial Travelers.

AT THIS time there are many travelers for jewelry houses on the road visiting the customers of the firms they represent. These gentlemen of the road, popularly known as commercial travelers, are entitled to great consideration at the hands of dealers. Commercial travelers are a comparatively new invention. It is but a few years since dealers were obliged to come to New York several times a year for the purpose of buying goods; these trips were costly, took much time and were not always satisfactory. Now the wholesalers send out their travelers and virtually place the New York market at the door of every dealer. The commercial travelers are the representatives of the firms that manufacture or handle the goods that every dealer must have; they carry samples of all the new styles and designs, from which the dealer can select an entire stock if necessary. This is something they should appreciate by giving the travelers a cordial reception. As a rule the dealers do this, and, whether they buy anything or not, are not lacking in courtesy. The life of a traveler, separated from home, family and friends, is a hard one at best; they are obliged to travel at all hours of the day and night, to put up with poor food at times and such accommodations as they can catch; their life is a hurly burly of travel and trade, with no time for relaxation or social enjoyment. Dealers whom they visit should take all these facts into consideration, and contribute what they can to make life pleasanter for them. We are aware that dealers are visited by travelers more frequently than seems necessary, but the dealers should remember that the great number of travelers indicates great competition and cheap goods; they can well afford, therefore, to spend a few minutes with each one and give him a few pleasant words. When manufacturers are bringing out so many new designs in all kinds of goods, every traveler carries samples that it will pay dealers to look over. One thing should not be lost sight of, and that is the representative character of the travelers. The traveler for Brown & Robinson has been selected because of the confidence that firm has in his ability to represent them in the retail trade, and the dealers are expected to treat him as they would a member of the firm. Commercial travelers are a necessary factor to the success of the jewelry trade, and should receive that recognition their importance entitles them to.

---

### The Retail Trade.

A NOTICEABLE IMPROVEMENT has been going on in the character and capacity of retail dealers during the past few years. They are steadily becoming better merchants, better buyers and better salesmen. Those of them who are practical workmen have learned that something more is necessary to make them successful as business men than the mechanical knowledge acquired in the workshop and at the bench. Once started in business for themselves as merchants, they have found themselves at a disadvantage beside those whose education was obtained in the office and counting room, and they have set themselves to work to so perfect themselves in business methods that the odds should not be so heavily against them. When they do this with a will and have patience and perseverance also, these practical workmen usually make successful

merchants mainly because they have been trained to economy, and, having to acquire business habits later in life, adhere to them more thoroughly, not indulging visionary dreams of lucky speculations and the accumulation of sudden wealth. In other words, they are more plodding and persevering than the majority of those who lack the discipline of a mechanical training. But dealers generally, whether mechanics or not, are falling into better business methods than they formerly had, and are thereby winning commendation from manufacturers and jobbers. They are showing greater skill and sagacity in buying than formerly, apparently better understanding their opportunities for selling advantageously, and refusing to buy what they don't want or to be overstocked with goods for which they have a limited demand only. They recognize, more fully too, the proper relations that should exist between debtor and creditor, and to realize the fact that a thirty day note has not three months to run. Their payments are more promptly made, their obligations better provided for than formerly, and their stocks are less encumbered than ever before. This improved condition of the retail trade is due largely to the increased growth of cities and villages, where development of the individual has kept pace with the development of his material surroundings. The small dealer in a country village had his ideas enlarged as the village grew to be a city, bringing with it competition, bustle, hurry-scurry and business. To catch his share of trade he has had to employ all his wits, and the result has been that he has developed into a business man of fair capacity. There are many unbusinesslike practices in the trade and there is still plenty of room for improvement, but old veterans in the trade say that they see marked advances made in the mercantile habits and methods of retail dealers. We are pleased to make note of the fact, and hope the time will come when retail jewelers will be developed into merchants of the highest class.

IN OTHER columns of this issue of THE CIRCULAR will be found the first annual report of the officers of the Jewelers' Security Alliance. This organization was formed about a year ago for the purpose of giving assistance to its members in case of their being robbed, and right well has it fulfilled its object thus far. When a member is robbed the Alliance assumes all responsibility for the pursuit and prosecution of the thieves, and spares no effort to secure the return of the stolen property, paying all the necessary expenses connected with the case. This is a great relief to the unfortunate jeweler who has been robbed; heretofore he has not only been compelled to submit to the loss of the goods, but to bear the burden of expense of the attempts to recover them or to capture the thieves. This has usually been found to be so great that the victim has felt inclined to compromise with the thieves, taking what he could get from them and permitting them to go unpunished. More frequently, however, he has not felt able to follow up the thieves so that they got away with the plunder and escaped punishment as well. The main purpose of the Alliance is to pursue the robbers with such vigor as to secure their conviction, and thus relieve the public from their depredations. During the past year the Alliance was instrumental in capturing three burglars, securing their conviction and having them sent to prison for long terms. In numerous instances the cause of justice was greatly aided by the efforts of the Alliance, and the criminal classes have come to have a most prudent respect for its certificates of membership. One of these conspicuously displayed by a retail dealer is better than a watchman, for it will effectually scare away prospecting depredators. The Alliance now has a rapidly increasing membership, but it should embrace the name of every jeweler in the trade. None are so strong as to be able to scorn the aid it offers, and none are so weak as not to need it. The officers of the Alliance are entitled to great credit for the able manner in which they have conducted its affairs, and for having given

their time and attention to it without money and without price. Their re-election was a foregone conclusion, and was a well deserved tribute to their fidelity and zeal.

"EXCELSIOR," who for thirteen years has been a liberal contributor to the columns of THE CIRCULAR, and who, by his practical essays on watchmaking, has done more than any other man to educate the watchmakers of the country, has issued a circular to the trade announcing that he has invented a new hair spring. His circular recites that the great obstacle in the way of securing a perfect timekeeper is the difficulty in obtaining a perfect balance spring. Two hundred years of study and experiment have resulted in giving us the balance springs now used, and these are confessedly not all that is to be desired. "Excelsior" has devoted many years to the study of this problem in watchmaking, and now offers a new form of hair spring which he claims unites in itself every desirable quality that it has ever been found possible up to the present time to obtain in any form of steel balance spring. This spring can be made more cheaply than any other, is equal to the best if not superior, and has other advantages that make it desirable. "Excelsior" does not propose to manufacture these springs, but his circular is designed to offer it for sale to whoever desires to make or use them. In short, he is open to offers for the whole of the patent or rights under it. All who are familiar with the writings of "Excelsior" will recognize at once the fact that he knows precisely what he is talking about when on the subject of watchmaking, and that he would not make a claim for any new invention that was not well founded. Persons desiring to communicate with him and who "mean business," can address him care of THE JEWELERS' CIRCULAR.

### The Jewelers' League.

*President*, GILBERT T. WOGLON.....Of Woglom & Miller.  
*First Vice-President*, WM. C. KIMBALL.....Of H. F. Barrows & Co.  
*Second Vice-President*, AUG. KURTZBORN.....Of L. Bauman Jewelry Co. St. Louis, Mo.  
*Third Vice-President*, JAMES P. SNOW.....Of G. & S. Owen & Co.  
*Fourth Vice-President*, HENRY HAYES.....Of Wheeler, Parsons & Hayes.  
*Secretary and Treasurer*, WILLIAM L. SEXTON.....Of Sexton & Cole.

#### EXECUTIVE COMMITTEE.

ROBERT A. JOHNSON, *Chairman*.....Of Colby & Johnson.  
 SAMUEL W. SAXTON.....Of Saxton, Smith & Co.  
 CLEMENT B. BISHOP.....Of Carrow, Bishop & Co.  
 JOSEPH B. BOWDEN.....Of J. B. Bowden & Co.  
 GEORGE R. HOWE.....Of Carter, Sloan & Co.  
 CHARLES G. LEWIS.....Of Randel, Baremore & Billings.

THE JEWELERS' CIRCULAR is the *exclusive* official paper of the Jewelers' League, and has been selected for the publication of all matters of interest pertaining thereto. Letters or inquiries pertinent to its business or purposes, and which might interest the trade or inquirers, will herein be answered. Address *Jewelers' League, Box 3,444, P. O., New York*, or the office of THE CIRCULAR.

AT THE meeting of the Executive Committee held May 2d, 1884, there were present Vice-President Kimball, and Messrs. Johnson, Lewis, Saxton, Bowden, Howe and Sexton.

The following 52 applicants were admitted to membership:

W. H. Jones, G. H. Howland, I. Guntzburger, J. H. Dunne, J. H. Burnett, H. Thomas, A. Westen, F. V. Steemwerth, J. W. Sherwood, C. F. W. Persch, M. J. Newwitter, M. Schindler, A. Liebeskind, G. E. Jones, A. Hodenpyl, H. P. Gray, D. Parrington, M. Buchner, E. Du Moulin, N. Y. City, N. Y.; J. C. Wilson, Rochester, N. Y.; E. Rivett, M. W. Smith, Boston, Mass.; S. Eastman, A. Vester, Providence, R. I.; A. Becker, W. E. Bovet, G. L. Richter, Newark, N. J.; A. J. Hood, Brick Church, N. J.; W. J. Johnston, Allegheny, Pa.; C. S. Wiley, Elizabeth, Pa.; E. Kinchberg, M. Newman, Chicago, Ill.; A. F. Kelsey, Elgin, Ill.; A. L. Hosmer, Quincy, Ill.; G. C. Schreiber, Lincoln, Ill.; F. J. Pratt, Jackson, Mich.; S.



D. Doty, Kirksville, Mo.; L. Commlossy, Indianapolis, Ind.; H. A. Leonard, Baltimore, Md.; F. E. Dey, Pensacola, Fla.; G. F. Beeland, J. H. Williams, Macon, Ga.; J. J. Ferguson, C. A. Schnack, Alexandria, La.; S. J. Hart, New Orleans, La.; J. C. Coleman, McKinney, Texas; W. C. Plaeffle, Georgetown, Texas; M. Roy, Houston, Texas; W. Salzmann, Galveston, Texas; W. Seeger, El Paso, Texas; J. L. Vredenburgh, Austin, Texas; J. A. Ingraham, San Francisco, Cal.

Treasurer reported balance of \$14,948.20. Six (6) changes of beneficiary were granted. Eight (8) applicants for membership were rejected. Eight (8) were referred for investigation, etc.

The Jewelers' League have published the report of the Chicago Special Committee, consisting of Messrs. Sonnenschein, Hale and Allen, on the final distribution of the Chicago fire fund. It is substantially as heretofore printed in THE CIRCULAR, gives a list, as far as possible, of the original subscribers to the fund, and the names of those who donated their interest to the League. It concludes by publicly complimenting the trustees, Messrs. Richardson and Randel, for the interest they had taken in the matter.

Samuel B. Mann, of J. T. Scott & Co., recently changed the beneficiary named in his certificate, and generously donates to the permanent fund of the League an interest therein equal to two per cent. of its value. This liberality on the part of Mr. Mann, who is not in affluent circumstances, is highly creditable to him, and furnishes an example which many others may well follow.

The office of the League is now at 170 Broadway, where members will receive a cordial welcome.

The following is a list of the amounts paid to beneficiaries of deceased members from organization (June, 1877,) to June, 1884:

|                             |                          |           |
|-----------------------------|--------------------------|-----------|
| 1. Chas. W. Menge.....      | Jersey City, N. J.....   | \$ 459 80 |
| 2. John J. Barker.....      | Brooklyn, N. Y.....      | 1,599 80  |
| 3. Thomas Slater.....       | Newark, N. J.....        | 1,647 30  |
| 4. George A. Harris.....    | Norwich, N. Y.....       | 1,776 50  |
| 5. James D. Nelson.....     | Jersey City, N. J.....   | 1,850 55  |
| 6. J. J. Acheson.....       | Brooklyn, N. Y.....      | 2,498 55  |
| 7. Geo. D. Stevens.....     | Orange, N. J.....        | 2,684 70  |
| 8. Samuel Strauss.....      | New York City, N. Y..... | 2,718 90  |
| 9. Andrew P. McGowan....    | New York City, N. Y..... | 2,882 30  |
| 10. John H. Willemin.....   | Springfield, Mo.....     | 3,142 60  |
| 11. Edwin C. Taylor.....    | New York City, N. Y..... | 3,117 90  |
| 12. Joseph Treulich.....    | Chicago, Ills.....       | 3,258 50  |
| 13. George A. Cory.....     | Jamestown, R. I.....     | 3,231 90  |
| 14. James A. Bogart.....    | Cranford, N. J.....      | 3,568 20  |
| 15. Ganson B. Holton.....   | Chicago, Ills.....       | 3,680 30  |
| 16. Hiram Sweet.....        | Atcheson, Kan.....       | 3,680 30  |
| 17. Wm. N. Evans.....       | New York City, N. Y..... | 3,805 70  |
| 18. Franz T. Forsberg.....  | Chicago, Ills.....       | 3,980 50  |
| 19. Dyer Brainerd.....      | Jersey City, N. J.....   | 4,193 30  |
| 20. Milton W. Jackson.....  | Macon, Miss.....         | 4,892 50  |
| 21. Chas. F. Livermore..... | Boston, Mass.....        | 5,000 00  |
| 22. W. J. Doherty.....      | Baltimore, Md.....       | 5,000 00  |
| 23. L. A. Cuppia.....       | New York City, N. Y..... | 5,000 00  |
| 24. Frederick Blauer.....   | Chicago, Ills.....       | 5,000 00  |
| 25. Elias Linz.....         | Sherman, Texas.....      | 5,000 00  |
| 26. James B. Goldey.....    | Brooklyn, N. Y.....      | 5,000 00  |
| 27. Geo. C. F. Wright.....  | New York City, N. Y..... | 5,000 00  |
| 28. David S. Barry.....     | Philadelphia, Pa.....    | 5,000 00  |

\$98,670 10

Average amount for each death.....\$3,523 93

Permanent and Contingent Funds on hand.....\$10,000 00

We regret to announce the death of three members of the League this year, which necessitates another assessment upon the membership. The following are the names of the deceased:

William H. Davis (No. 2981), a retail jeweler of York, Penn., joined the League on December 7th, 1883. He died on the 19th day of February, 1884, of meningitis, after a sickness of only one week. His age at death was 28 years. His mother is his beneficiary.

Walter S. Cook (No. 663), of Chicago, Ill., when he joined the

League on April 3d, 1880, was in the employ of C. H. Knights & Co., of that city. He died on March 2d, 1884, of consumption. His age at death was 33 years. His wife is his beneficiary.

John W. King (No. 117), a retail jeweler at Jacksonville, Ill., joined the League on January 3d, 1878. He died on the 4th of March, 1884, of chronic otitis, after a sickness of four weeks. His age at death was 49 years. His wife is his beneficiary.

### The Jewelers' Security Alliance.

President, DAVID C. DODD, JR.

Vice-President, AUGUSTUS K. SLOAN.....Of Carter, Sloan & Co.  
Treasurer, W. C. KIMBALL.....Of H. F. Barrows & Co.

#### EXECUTIVE COMMITTEE.

C. G. ALFORD, *Chairman*.....Of C. G. Alford & Co.  
C. B. BISHOP.....Of Carrow, Bishop & Co.  
HENRY HAYES.....Of Wheeler, Parsons & Hayes.  
J. B. BOWDEN.....Of J. B. Bowden & Co.  
DAVID UNTERMAYER.....Of Keller & Untermeyer.  
E. F. DORRANCE.....Of Dorrance & Brother.

P. O. Box 3277.

Room 2, 170 Broadway, New York.

HON. ALGERNON S. SULLIVAN, *Counsel.*

THE FIRST annual meeting of the Jewelers' Security Alliance was held at their rooms, 170 Broadway, May 6, Mr. David C. Dodd, Jr., presiding. Considerable routine business was transacted, and the Treasurer, Mr. William C. Kimball, submitted his report, showing a very satisfactory condition of affairs, and an ample balance on hand to provide for probable requirements. Mr. C. G. Alford, Chairman of the Executive Committee, read the report of that body, which, as it is of much interest to the trade in general, we print substantially as read:—

During the months of March and April, 1883, the necessity of combined effort to prevent the frequent robberies of jewelers' safes became apparent to a number of the manufacturers and jobbers of New York, and after a number of preliminary meetings for discussion, and the appointment of Committees to prepare Constitution, By-Laws, etc, the Jewelers' Security Alliance was organized at a meeting of the trade April 25th, 1883.

At a subsequent meeting of the officers held the same day, Mr. C. B. Bishop was elected Chairman of the Executive Committee.

During the year your Committee have held 29 regular and special meetings at which 379 members have been admitted, and a large amount of routine business transacted.

While our growth was slow during the first three quarters of the year owing in part to the difficulty of making known to the trade the benefits of the Alliance in case of burglary, and also the fact that by many it was considered an experiment requiring time to determine its feasibility; the following exhibit of members for each quarter of the year we think most convincing proof of its ultimate success.

|   |     |
|---|-----|
| Members received quarter ending Aug. 1st..... | 52  |
| “ “ “ “ Nov. 1st.....                         | 71  |
| “ “ “ “ Feb. 1st.....                         | 74  |
| “ “ “ “ May 6th.....                          | 182 |

At the meeting of the Committee July 13th, 1883, the robbery of Myron Dubois, of Ellenville, New York, was brought to our notice.

The numerous burglaries of jewelers prior to this convinced the members of your Committee that some steps should be taken to prevent their continuance.

Dubois not being a member of the Alliance (at that time), we could not, as an institution, take the case in hand with view of prosecuting it with the funds of the Alliance, but as merchants we authorized Allan Pinkerton to investigate and report to us. The recovery of the goods and the arrest of the thieves speedily followed.

In due time a long and expensive trial took place at Kingston, New York, at which the personal attendance of Mr. Robert Pinker-

ton was required for three weeks, and for which we found it necessary to procure a large number of witnesses.

The thieves employed eminent counsel, and with a large sum of money contributed by their associates, stubbornly contested the case; but in spite of their efforts we secured the conviction of three of the most skillful and notorious burglars in the country, and they were sentenced to States prison for five years, and are now serving out their sentences.

The set of tools used in this burglary, weighing but five and one-half pounds, are now in the possession of Pinkerton, and are remarkable as evidence of the skill and ingenuity of the professional burglar, a half hour's time being all that is necessary for them to go into any ordinary safe.

During the trial a safe was opened in the presence of the court showing their mode of operation.

The total expense connected with this case exceeded \$2,200. The members of your Committee became *personally* responsible for this amount, and will endeavor through their *own subscriptions* as merchants, and the subscriptions of the wholesale trade, to liquidate this bill.

The members of the Alliance and the trade at large are to be congratulated upon the results attending our efforts in this case.

Up to November last our efforts for securing members had been confined to the issuing of circulars, writing personal letters and personal solicitation of members of the Committee and of our Secretary as opportunity presented itself.

Since that time our Secretary, Mr. H. W. Hiller, has made five trips to points in New England, New York, New Jersey and Pennsylvania, visiting nearly 100 towns and cities.

In addition to the members that he has obtained in this way, we feel very confident that a large number will become members during the ensuing year as the *outcome* of his solicitation.

We have issued during the year some 20,000 circulars, and the different members of your Committee have together written about 1,000 personal letters, and now, at the outset of our second year, we feel justified in saying that the trade, to a large extent, understand the objects of the Alliance, and that we can safely predict a rapid growth and a financial basis ample for the protection of our members, and sufficient to establish ourselves as an institution which burglars will not care to disturb.

On March 13th, of the present year, Mr. Bishop, on account of ill-health, resigned his position as Chairman of your Committee, and your present Chairman was elected in his place.

The Committee desire to express their appreciation of the eminent services rendered by Mr. Bishop in the organization of the Alliance, and his subsequent services as Chairman of the Committee.

On Dec. 14th, Mr. P. T. Tunison, after faithful and earnest work, resigned his position as Treasurer, his resignation to take effect upon the election of his successor, and on Dec. 28th, Mr. Wm. C. Kimball was elected in his place.

For the first ten months of the year the Alliance occupied as an office a small portion of the store of Messrs. Carrow, Bishop & Co., 14 John street, the Committee holding their meetings there, or at the offices of the different members of the Committee.

March 15th we rented and furnished our present office at 170 Broadway, to which members are at all times welcome.

In conclusion, while the expenses attendant upon our organization, the necessity of publicity through circulars, letters and personal visitation of our Secretary to different towns and cities, have been considerable in amount, they are likely to be much less in proportion to the future membership.

With a membership of nearly 400 for our first year, not one of whom has been molested, we unhesitatingly recommend the Alliance to the trade and solicit for it the support that it merits.

The officers of the preceding year were all re-elected for another term. Mr. Dodd, on accepting the presidency for a second term, spoke at length of the important work the Alliance is doing, and

stated the fact that since its organization not a single jeweler who displayed his certificate of membership had been molested by burglars. The criminal classes understand that the Alliance will protect its members at any cost of money or time, and they deem it prudent to let them alone. One of the burglars who was convicted of the Ellenville robbery, referred to in the report, stated that they first looked over the place for an Alliance certificate, and, learning that the jeweler was not a member, they ventured to proceed with the robbery. The Alliance, however, took up the matter, and secured the conviction of three of the culprits, although they were defended by the best legal talent and were backed by the money and influence of the best organized gang of thieves in the country. Owing to the persistency of the Alliance justice did not miscarry, as it too frequently does. He also complimented the officers for the disinterested manner in which they had discharged their duties, giving freely of their time and money to secure its success.

The following named applicants were admitted to membership at the meetings of the Executive Committee held April 26th and May 5th, 1884:

B. A. Ballou & Co., Providence, R. I.; Bates & Bacon, N. Y. City; H. P. Buckley, New Orleans; Chas. A. Boas, Harrisburg; T. F. & M. J. Bogle, White River Junction, Vt.; C. L. Byrd & Co., Memphis, Tenn.; T. P. Bedilion, Pittsburgh, Pa.; John Baumer, Omaha, Neb.; Jacob Bennett & Son, Philadelphia; A. H. Binns, N. Y. City; C. A. W. Crosby, Boston, Mass.; C. H. Case, Hartford, Conn.; S. & T. Child, Philadelphia; A. H. Duerr, Philadelphia; Jos. K. Davison, Philadelphia; Day & Clark, Newark; Chas. Downs, Providence; Dorrance Bros., N. Y. City; C. M. Englehart & Son, Philadelphia; W. F. Fischer & Bro., Chattanooga; A. H. Felting, Baltimore; Robt. C. Green, Pottsville, Pa.; Glorieux & Woolsey, Newark, N. J.; J. G. Gehring & Son, Baltimore; J. W. Haight & Co., Auburn, N. Y.; Harris & Southwick, Providence; Howard & Son, Providence; Hodge, Slemmons & Co., Pittsburgh; W. S. Hough, Jr., & Co., Providence; A. Hirsch & Co., Chicago; Hennegen, Bates & Co., Baltimore; Johnson Bros., Rome, Ga.; R. A. Johnquest & Co., Ansonia, Conn.; Keller & Bro., Allentown, Pa.; L. & M. Kahn & Co., N. Y. City; Wm. F. Kercher, Philadelphia; Chas. B. Lynch, Philadelphia; G. E. Luther & Co., Providence; Morck Bros., Warren, Pa.; Fred. I. Marcy & Co., Providence; Emanuel Marks & Son, Troy, N. Y.; J. S. MacDonald, Baltimore; D. Oppenheimer & Bro., Baltimore; Carl Petersen, Washington; J. G. Rennard, Phoenixville; H. M. Shreiner, Lancaster, Pa.; Schlecter & Henry, Reading, Pa.; R. F. Simmons & Co., Attleboro Falls; O. O. Stillman, New Brunswick; Reinhold Siedle, Pittsburgh; B. H. Stief, Nashville; Thornton Bros., Providence; Geo. L. Vose & Co., Providence; Voorhees & Van Wickle, New Brunswick; H. B. Vincent & Bro., McConnellsville, O.; J. Wetherell & Son, Parkersburg; A. F. Williams, Trenton; Frank Weidenfeld, Suffolk, Va.; Leopold Weil & Co., N. Y. City; E. J. Zahm, Lancaster, Pa.; L. Sonnenschein & Bro., Chicago, Ill.; James McKee, Pittsburgh; A. G. Weber, Pittsburgh; H. Best & Son, Dayton, O.; A. C. Margot, Port Jervis, N. Y.; J. F. Sturdy & Sons, Attleboro Falls; Geo. W. Chatterton, Jr., Springfield, Ill.; Young & Bennett, No. Attleboro, Mass.

---

[Copyright Secured.]

### The Cup—Its Art and Customs.

[BY JOHN W. MILES.]

*Continued from page 101.*

ENGLISH plate, at the beginning of the 16th century, differs little in general design from the Leigh cup already figured. The same trumpet-shaped stem and ornamented cross-bands characterize the standing cups, and this decoration was also applied to beakers. One of the latter, presented to Christ's College by Countess Margaret of Richmond, is illustrated in figure 45. It is of silver gilt, resting upon a battlemented base in the form of a Tudor rose. A chain encircles the cup where it joins the base. At each intersection of the cross-bands is a *marguerite*, while the spaces are filled alternately with Tudor roses and portcullises—the *marguerites*, an emblem of

the Countess' name, and the portcullises formed as its initial letter. The cover, battlemented and similarly diapered, is surmounted by a



Beaker, A. D. 1507, Figure 45.

hexagonal ornament composed of six portcullises with a finial of four *marguerites* and a Tudor rose. It is probably of French manufacture. The same college is in possession of a standing cup ornamented with *repoussé* imbricated work, but the shape is too nearly similar to the Leigh cup to require an illustration.

We come now to a decided and radical change in the ruling styles of English art. The Gothic almost entirely disappears, giving place to designs more nearly in accordance with the prevailing taste of Italy and France. Such is the silver gilt cup at Barber Surgeon's Hall, London, and dating 1523, figure 46. The simple elegance of form recalls the purity of Grecian work, and the use of the acanthus



Cup at Barber Surgeon's Hall, London, Figure 46.

aids the delusion. It was presented to the Barber Surgeon's Company by Henry VIII., whose arms surmount the cover. The ornamentation includes the rose, portcullis and *fleur-de-lys* in *repoussé*,

together with four pendant bells. A period of forty-six years occurs between this and the succeeding illustration, figure 47, which is of a silver gilt standing cup at Corpus Christi College, Cambridge. It is quite tall (21  $\frac{1}{4}$  inches) and a fair type of the best English renaissance work. Cup, stem and base are covered with *repoussé* work and chasing of grotesque masks, flowers and fruit. The cup, chased with strap-work and foliated arabesques, has three medallions containing female heads in high relief. The expanding lip has three cherubs' heads also in relief, and the cover is surmounted with a nude male statuette. The entire cup is in unison with the spirit of the age—a



A. D. 1569, Figure 47.

spirit endeavoring to portray the highest artistic thought and feeling in the noble metals. We have reached the Elizabethan era, a period crowded with master minds, and though we cannot in England, as in Italy, France and Germany, designate any individual goldsmith as a leader among the craft, their work proves that they were not insensible to the influences of the hour. It was an age rich in mental conceptions, and if Italy boasted of the superiority of her artists, England could point with equal pride to a Shakespeare, a Bacon and a Spenser.

Mention has been made of wooden tankards. No article of plate, however, bears this name previous to the 16th century, when some of very elaborate design were produced. The one illustrated in figure 48 is at Clare College, Cambridge, and is called the "Poison Cup," on account of the crystal set in the cover, which was believed to have the property of detecting poison. The interior of the tankard is of glass enclosed in a filigree wire casing of silver gilt resting upon three cherubs' heads. The upper and lower band, as well as the upper portion of the handle, is thinly engraved with vine and leaves in the style of the woodbine, while intervening bands have projecting masks, strap-work and small floral designs. It is dated 1570. A tankard in the Ashmolean Museum is widely different yet

not less artistic, figure 49. It is of solid silver gilt, with sides tapering to the top and surrounded with two bands of "egg and tongue" ornament, with a third around the cover. Bands of the popular woodbine style are also seen, and the strap-work, cartouches, medal-



"Poison Cup" at Clare College, Cambridge, Figure 48.

ions with female heads, fruit and lions' heads are but types of the prevailing style of decoration that belongs to the period. *Repoussé* or beaten work in high relief was executed by the English artist with great skill. Representations of sea nymphs and deities that occur on some of the plate belonging to the Corporation of Norwich are beautifully wrought, reminding one of the exquisite details of the Milton Shield.



Tankard at Ashmolean Museum, A. D. 1574, Figure 49.

Cocoa-nut cups still remained, but the mountings were more tasteful, in accordance with the increased development of the beautiful in art. A cup of this character at New College, Oxford, figure 50, is much more elegant than the one represented in figure 34. The base

is ornamented with strap-work and fruits and flowers in *repoussé*, and, with the stem, is a good example of the Elizabethan style. It has not, however, the interesting history of the cup at Oriol College,



Cocoa-nut Cup at New College, Oxford, 1584, Figure 50.

the nut forming the bowl of the latter being a driftwood nut thrown upon the coast of Great Britain by the Gulf Stream—a message to the old world from America twelve years before the famous voyage of Columbus.

The drinking utensils in *common* use by the English were bell-shaped glasses very similar to those employed by the Saxons two or three centuries previous. Some of them are represented in figure 51. Owing to their peculiar shape they could stand only in a reversed



Figure 51.

position, consequently they had to be emptied at one draught. There does not appear to have been much attempt at decoration, if we exclude the taller ones of the group, and particularly the one of "twisted" pattern so often mentioned in "Beowulf." There is one at South Kensington, however, that is mounted with a hollow sphere in silver enclosing a dice and surmounted with a small statuette of Fortune. Another has a bell attached to the mounting. Upon being emptied the dice was shaken or the bell tinkled as a finale.

(To be Continued.)

Aristarchius Plumbago and his Bicycle Watch Movement.

YOU HAVE done me a grievous injury in the columns of THE CIRCULAR, and I desire to ventilate my grievance. You have long been familiar with the fact that I am a genius of the first water and a promoter of manufacturing enterprises who has not a rival in the world. From time to time I have taken you and your readers into my confidence to the fullest extent that I thought would serve my purposes, and have written full particulars of various enterprises that I had in hand. With this you should have been satisfied, and

given me your exclusive aid and encouragement in fostering those enterprises. But I had, in addition, various other irons in the fire in connection with which I did not, for pecuniary reasons, care to show my hand. It was not policy to "boom" them and so I kept quiet. Not so THE CIRCULAR. No sooner did it hear that a new watch company was to be established somewhere or nowhere than it forthwith directed attention to the fact, and thus brought the scheme prominently forward. On several occasions your altogether too previous announcements of my plans have interfered with ulterior purposes I had in view not wholly unconnected with real estate transactions. You have thus compelled me to show my hand, and to beg of you in future to have nothing whatever to say regarding new watch companies that you may hear of till I give the word, and then "boom" them all you can. I have to inform you that I am the projector, inventor, designer, architect and principal stockholder in every one of the schemes for the formation of new watch companies that has been broached for the past five years. They are all mine, originating in the gigantic intellect of your old friend, Aristarchus Plumbago. I am sure if you had known this before you would have delayed booming them till the plans were ripe in all their details. Hereafter it will pay you to mind your own affairs as a permanent occupation, and only to give me your services when I request them. Leave these matters in my hands and I promise to make a millionaire of you inside of twelve months; my brain is prolific and I can do it; but cross my path again, thwart me in any future project, as you have in the past, and I'll crush you as I would a serpent. THE CIRCULAR is not omnipotent, and I will stamp it under my heel if it interferes with my future plans, and don't you permit it to escape your recollection.

But that you may avoid trespassing upon my preserves I will outline my plans. I have been called the Great American Promoter of Watchmaking Enterprises. I propose to deserve that title. I have had considerable experience in this line of industry, but my works in the past are nothing compared to what they will be in the future. Various watch companies that I have projected have been of an evanescent, not to say incandescent, character, owing to the fact that the fulfilment of theoretical promises was impossible of realistic performance—in other words, the movement upon which the companies were projected was not up to the requirements of practical utility—in short, it wouldn't work. But I have now the bicycle movement, conceived by me while basely incarcerated in a vile asylum for degenerate man in the wilds of Illinois, and of its absolute success there can be no question. As you already know it consists of but two wheels, a big one and a little one. I have not yet succeeded in making a watch upon this principle that will run, but I have diagrams giving front, back and side views, together with the rear elevation, and when I have secured all the capital I desire I have no doubt but some one will, from these plans, be able to make a movement that will move. With the bicycle movement perfected, horology as a science will be condemned to keep company with Beecher's "Life of Christ," which, according to Sam Wilkeson, was "knocked higher'n a kite." Horology nor science has anything to do with it—there is no superfluous machinery to get out of order; no cut balance, no adjustments, no escapement. This latter qualification applies especially to stockholders—once a stockholder always a stockholder—with all that the name implies, including periodical assessments. Being the patentee and sole owner of this bicycle movement, I propose to organize companies for its manufacture in all sections of the country. Every city, village or town having a population of 3,000 inhabitants ought to have a watch company manufacturing bicycle watches. There will be a demand that will take all that can be made. I have before laid it down as an axiom that the wearing of a watch tends to the civilization of the wearer; in fact, the watch may be regarded as the badge of civilization. If, therefore, the wearing of one watch has such a soul-elevating effect upon the individual, what may we not expect from the multiplication of watches upon the person? What intellectual and moral advance-

ment we shall have made when the average man wears three or four watches, and the more refined and cultured from one to six dozen? The bicycle movement will be made in every conceivable form, for, as I have before explained, it is immaterial how the two wheels are placed relatively to each other. Therefore, we can make them like ordinary watches, as charms, scarf pins, finger rings, cane heads, ear rings, buttons for wearing apparel for both sexes, buckles for ladies' shoes, and, in fact, in every conceivable form and shape for utility or ornament. I expect to revolutionize the tailoring and dressmaking trades, for our movements will be made in such attractive forms that they will supersede every style of button now in use. How refreshing it will be to see a learned professor held together by suspenders attached to buttons enclosing bicycle movements. What an edifying spectacle to see a modern "dude" deriving sustenance from the head of a cane which encloses a bicycle movement, while the accompanying "dudess" flourishes a parasol in the handle of which a similar movement is concealed. This will suffice to indicate how universal will be the demand for bicycle watches, and how necessary that they shall be made in sufficient quantities to meet it. A watch factory in every hamlet in the country will be required to supply the home demand, to say nothing of the export trade that will spring up as soon as the trumpet of fame shall have sounded the merits of this grand invention over the roofs of the world.

I am now engaged in the work of organizing the companies required. My plan is to go to a city and enlist the co-operation of residents, especially those who have private enterprises to encourage or real estate to market. Recently in one place real estate owners gave me a large tract of land as a site for the factory, and the management of a street railway subscribed liberally to the stock of the watch company. The announcement that the factory was to be built made a "boom" in real estate at once, and the stock of the railway advanced immediately to par, thus enabling these enterprising citizens to unload at profit upon their neighbors. It is expected that newspapers will offer them as premiums instead of chromos; they will also be sold by hardware dealers, dry goods merchants and druggists. Imagine how convenient it will be for a man to buy a box of pills and have a guaranteed movement thrown in. Recently while on a visit to Washington to secure a patent on my newly invented wash tub and chicken incubator combined, I enlisted the co-operation of some distinguished government officials, not far from the Executive Mansion, in the bicycle movement. These gentlemen own considerable real estate on the Potomac flats very desirable for a watch factory. The company was formed, a site selected in this locality, and the officials referred to are large stockholders. Through their disinterested influence contracts have been closed with the army and navy departments, in accordance with which we are to manufacture all government buttons in the future with the bicycle movement enclosed. A contract is negotiating with the Interior Department in pursuance of which all repeating rifles hereafter issued to the Indians will have a bicycle movement inserted in the breech, while every cartridge dealt out will have a miniature movement rammed down with the powder. Similar cartridges will be introduced in the army and navy, while all large ammunition hereafter used by the government will contain several movements according to its caliber. It is confidently expected that with this ammunition the enemies of our government will be knocked out of time in the first round. I expect the Washington factory, under the patronage of government officials, to be one of the most profitable in the country. I had to divide out the stock more liberally than usual, but I still retain a desirable block of it. The bicycle movement can be manufactured with little cost. As before explained, I intend to employ convict labor as much as possible, but as the number of convicts is limited, and as it is desirable to have some in every town, I shall offer a premium for crime, so that every community will require a prison in which to confine its gang of watchmakers. No intelligence is required to make the bicycle movement—in fact, the less intelligence employed the better the movement. All the tools

required are a hammer and a flat stone, and all the metal a piece of strap iron. With such inexpensive materials the margin of profit is illimitable. But I will elaborate no more at present; your imagination will fill in the details of my colossal scheme. Suffice it to say that all new watch companies now organizing or to be organized are under my auspices and for the furtherance of the scheme I have outlined. You are, therefore, requested to make no mention of any of them in your columns till I communicate with you. I have indicated the penalty for neglect to comply with my request. Beware! Beware!!

Yours as I shall find you,

ARISTARCHIUS PLUMBAGO.

P. S.—In carrying my plans into effect I find myself temporarily in an impecunious condition. Could you refer me to some capitalist who would advance me two dollars and a half on my note of hand at thirty days? I would be willing to hypothecate my patent on the bicycle movement as collateral if required.

ARISTARCHIUS P.

Naval Institute, Washington Branch.

NOVEMBER, 1883.—U. S. N., in the Chair.

*Method of Testing Chronometers at the U. S. Naval Observatory.*

BY LIEUTENANT E. K. MOORE, U. S. N.

*Continued from Page 75.*

EACH CHRONOMETER running at the observatory has a card with its curve constructed and rates plotted up to date, so that in the selection of a chronometer for any purpose, its record since it was last cleaned can be seen at a glance, and the one selected whose compensation is most suited to the temperature in which it is to be used. When the chronometer is issued, a copy of the card goes with it, showing the curve and last rates at different temperatures.

The rates are to be kept plotted during the cruise, and the cards returned to the observatory with the chronometers.

This curve being a parabola, the general equation  $y^2 = 4ax$  satisfies all its conditions.

Substitute for  $y$ ,  $(y-b)$  and for  $x$ ,  $(x-c)$ ;

$$\text{Whence } y^2 - 2by - 4ax = -b^2 - 4ac = c', \tag{6}$$

$$\frac{1}{4a} = \frac{x}{y^2}, \tag{7}$$

$$xn = \frac{1}{4a} y^2 n. \tag{8}$$

From the record of No. 729 Negus, substitute the several values of  $x$  and  $y$  in (6), letting  $68.3^\circ$  be the axis of  $x$ , and 0 seconds the axis of  $y$ , and solve for the coordinates of the vertex.

$$x = +1.122s. = r, \text{ and } y = -0.74^\circ. \therefore \theta = 67.56^\circ.$$

With coordinates passing through the vertex, from (7),

$$\frac{1}{4a} = -0.00302 = z.$$

Substituting these values in (8) we have,

|       |          |       |          |       |          |       |          |       |          |
|-------|----------|-------|----------|-------|----------|-------|----------|-------|----------|
| Temp. | Rate.    | Temp. | Rate.    | Temp. | Rate.    | Temp. | Rate.    | Temp. | Rate.    |
| 45°   | -0.414s. | 50°   | +0.192s. | 55°   | +0.646s. | 60°   | +0.950s. | 65°   | +1.102s. |
| 70°   | +1.103s. | 75°   | +0.944s. | 80°   | +0.653s. | 85°   | +0.202s. | 90°   | -0.400s. |

The same are obtained by (2), (3), (4) and (5).

The more accurate the observations for rate and temperature, the more accurate and satisfactory, of course, will be the result; but with the present accurate methods in general use for determining longitude, and the additional facilities for rating by telegraphic signals, time balls, etc., (2), (3), (4) and (5) can be used with close approximation on board cruising vessels where no temperature-rate has been furnished, or for testing that already given.

For this purpose rates should be obtained as frequently as possi-

ble, the observer noting carefully the temperature of the chronometers between the observations; for this purpose no chronometer box should be without a good maximum and minimum thermometer. Having obtained a sufficient number of rates at different temperatures, say eight or more, divide them into three sets, putting in each set two or more taken at nearly the same temperature. Reject those that differ too greatly from the average temperature of their set, remembering that the change of rate is as the square, and not directly as the difference of the temperature. Reject also any rate that is phenomenal, for the best chronometers will sometimes run wildly for a term or two without apparent cause and then come back again to their usual rates.

Take the mean rate and mean temperature of each set and substitute them in (2), (3) and (4). A convenient way to form the sets is to plot the rates on the card as before described, then to combine in groups those of nearest temperatures and rates.

Chronometer No. 1262 Negus, Plate VIII, was worked up and plotted in this way. It was running at the observatory from January 6, 1880, to August 18, 1881, when it was issued. It was again returned to the observatory March 1, 1883, having been in service afloat. Its record is as follows:

*Mean date, April 11, 1880.*

| Temp.                   | Rate.    | Temp.           | Rate.    | Temp.          | Rate.    |
|-------------------------|----------|-----------------|----------|----------------|----------|
| Jan. 16, 59.0°          | -1.448s. | Mar. 6, 66.7°   | -0.936s. | July 4, 82.5°  | -2.180s. |
| Feb. 15, 56.0           | -1.670   | Apl. 5, 63.7    | -1.145   |                |          |
| Feb. 25, 59.5           | -1.394   | Apl. 15, 64.5   | -0.979   | July 14, 84.3  | -2.341   |
| Mean, 58.2°             | -1.504s. | 65.0°           | -1.020s. | 83.4°          | -2.260s. |
| $\theta = 68.07^\circ.$ |          | $z = -0.00550.$ |          | $r = -0.968s.$ |          |

*Mean date, April 29, 1881.*

| Temp.                   | Rate.    | Temp.           | Rate.    | Temp.          | Rate.    |
|-------------------------|----------|-----------------|----------|----------------|----------|
| Jan. 20, 56.5°          | -1.694s. | Apr. 10, 71.3°  | -0.762s. | July 19, 83.2° | -1.910s. |
| Jan. 30, 56.6           | -1.733   |                 |          | Aug. 8, 82.2   | -1.936   |
| Apr. 10, 56.0           | -1.297   | May 10, 68.9    | -0.709   | Aug. 18, 81.1  | -1.802   |
| Mean, 56.4°             | -1.537s. | 70.1°           | -0.735s. | 82.2°          | -1.883s. |
| $\theta = 68.31^\circ.$ |          | $z = -0.00604.$ |          | $r = -0.716s.$ |          |

*Mean date, April 17, 1883.*

| Temp.                   | Rate.    | Temp.           | Rate.    | Temp.          | Rate.    |
|-------------------------|----------|-----------------|----------|----------------|----------|
| Mar. 11, 53.8°          | -0.768s. | Apr. 21, 73.0°  | +0.707s. | Apr. 29, 85.2° | +0.011s. |
| Mar. 31, 55.0           | -0.562   | May 19, 72.9    | +0.866   |                |          |
| Apr. 6, 55.0            | -0.550   | June 5, 73.6    | +0.696   | May 8, 85.0    | -0.149   |
| Mean, 54.6°             | -0.627s. | 73.2°           | +0.756s. | 85.1°          | -0.069s. |
| $\theta = 71.79^\circ.$ |          | $z = -0.00471.$ |          | $r = +0.765s.$ |          |

The above data were taken from the records of the chronometer, without application of the effect of time, running in natural temperatures; the highest temperature for 1883, however, was obtained in the temperature room. The sets were selected by grouping the rates near the same temperature, the dotted lines showing the groups used, and the dots,  $\odot \times \Delta$ , the mean rates and temperatures, each for ten days, during the time under comparison. The values of  $\theta$  and  $z$  remain practically constant for 1880 and 1881, and change but little for 1883. A portion of this change may be attributed to the coefficient of time, which has not been considered.

$r$  changes more or less with time in all chronometers, generally increasing if its sign is +, and decreasing if it is -. That is, from the time of cleaning, chronometers, as a rule, run faster as their age increases. This is especially so with new chronometers, which sometimes take two or three years to settle down to a steady rate. Not unfrequently do they gain, in the course of a three years' cruise, three or four seconds on the rates given them when issued. This change is gradual, and the daily acceleration or retardation is the coefficient of time.

Let  $T$  be the date at which the rate at a given temperature is  $r$ ;

$T_1$  any other date at which the rate at the same temperature is  $r_1$ ;  $T_1 - T = t$ , the elapsed time, and  $g$  the coefficient of time.

$$\text{Then } g = \frac{r_1 - r}{t} \quad (9)$$

And (1), the general equation of the chronometer, becomes

$$r' = r + z(\theta - \theta')^2 + gt. \quad (10)$$

With No. 1262 Negus, from April 11, 1880, to April 21, 1881,  $g = +.00067$ ; and from April 21, 1881, to April 17, 1883,  $g = +.00204$ . Owing to the change of  $\theta$  and  $z$  the latter value of  $g$  was a little larger for temperatures above  $70^\circ$ , and a little smaller for temperatures below  $70^\circ$ .

In the ordinary uses of the chronometer for navigation purposes, the last term,  $gt$ , of equation (10), may be, and should be, omitted, as the value of  $g$  may change with time, and its use would indicate a greater degree of accuracy than would actually be obtained. Again, its value is always small, and the accumulated error from its rejection would come within the probable error of observation when ratings are frequent. It should, however, always be used in the establishment of longitude by meridian distances, and in other work where back calculations are made.

The temperature corrections should be used at all times, more especially when changes of temperature are frequent and extreme, and in making long voyages. A change of a few degrees in the higher or lower temperatures will change the daily rate one or more seconds, soon making the accumulated error amount to several miles in longitude. It is well to keep the chronometer record up for temperature even while lying in port, as it gives the navigator a knowledge of how it is running, and shows him what reliance he can place upon it at sea. By reference to Plate VIII, it will readily be seen what the effect would be on the rate of No. 1262 Negus were it rated in about  $68^\circ$ , and then taken into a temperature of either  $55^\circ$  or  $80^\circ$ , as often occurs.

Having determined the curve, on obtaining a rate at any subsequent time, if the rate does not plot on the curve, the difference will be a constant to be applied to all rates taken from the curve at different temperatures.

Great care should be taken when chronometers are suspended in their gimbals that they swing perfectly free, but without play enough to give them a jar; and the gimbals should be so adjusted that the chronometers will always hang with their faces level.

Nos. 725 and 1262 Negus, both running very regularly and adhering closely to their curves, were canted  $9^\circ$ , first with the XII down, then with the VI, IX and III down successively, leaving them two terms of seven days in each position, and placing them level again for two terms between the successive changes. They both lost on their level rates, varying from five-tenths to three seconds, and were more or less irregular; but when placed level again they each time came back to their regular rates, running a little irregularly at first.

Their mean rates, reduced to a temperature of  $70^\circ$ , were as follows:

*No. 725 Negus.*

Face level,  $+0.72s.$ ; XII down,  $-2.18s.$ ; level,  $+0.77s.$ ; VI down,  $-1.27s.$ ; level,  $+0.78s.$ ; IX down,  $+0.17s.$ ; level,  $+1.01s.$ ; III down,  $-1.21s.$

*No. 1262 Negus.*

Face level,  $+0.74s.$ ; XII down,  $-0.20s.$ ; level,  $+0.82s.$ ; VI down,  $-1.70s.$ ; level,  $+0.75s.$ ; IX down,  $-2.36s.$ ; level,  $+0.84s.$ ; III down,  $-2.65s.$

The above changes are not excessive for chronometers slightly canted, and the cant is what would take place were the screws in one of the adjusting slots of the gimbals to become loose, allowing the bowl to slide to one side or the other.

At some time during the trial, after the chronometers have passed through the temperature test, and their curves have been determined, they are rated for one term of seven days each with the XII of their

faces North, South, East and West successively, as a test for polarity; and should any evidences be found, they are again put through the different positions to make sure that the irregularities are not merely coincidences. Chronometers having actual polarity are at once rejected.

The chronometers are relatively placed after trial by the trial number, which is: Trial number =  $(69^\circ - \theta) + 1000z^2 + 10v^2$ , in which  $69^\circ$  Fahr. is the temperature at which the chronometers should be compensated to have their fastest rates, and it is obtained by taking for a number of years the mean of the chronometer boxes of several vessels of the navy serving on different stations.  $z$  is the temperature-constant and  $v$  the arithmetical mean of the five greatest variations of the mean rates from the curve as determined by formula (5).

$(69^\circ - \theta)$  should in no case exceed  $10^\circ$ , except in chronometers compensated for special purposes, and it should be allowed to approach  $10^\circ$  only when  $z$  is very small, making the curve nearly a straight line.  $z$  should in no case exceed  $.006$ , and should be allowed to approach it only when  $(69^\circ - \theta)$  is very small, thus placing the large variations of rate, due to temperature, in the extremes to which the chronometers would seldom be subjected.  $v$  should in no case exceed  $0.50s.$ , making due allowance for coefficient of time, especially in new chronometers.

Chronometers failing to pass the required trial are returned to their makers, and rejected, if new and for purchase; but if old ones, having been cleaned and repaired, they are to be recomensated free of charge and returned for a new trial.

Chronometers for service are selected with a view to the temperature in which they are to be used. Those for warm climates should have their point of compensation highest, and those for cold climates the reverse. Those to be used in both cold and warm climates should have their temperature-constant small; and in all cases the smaller the value of  $z$  the nearer the curve will approach a straight line and the better will be the chronometer, all other things being equal. On being issued, chronometers are transported by hand direct from the observatory to their destination while still running, and are handled with the greatest care. For transportation they are taken from their gimbals, wrapped closely in paper and placed level in a basket of cotton, cushioned around the edges and from each other, but not tightly packed. They are delivered to the navigation officer of the navy yard or of the vessel, as the case may be, when the supervision of the observatory ceases until their return. Their boxes are enclosed in the transporting cases, neatly crated, and sent as freight.

In transportation the principal things to be guarded against are circular motion and placing them in any other position than a level one. If their error and rates are to be carried on in transportation, a maximum and minimum thermometer should be packed in the basket as near as possible to the chronometers to obtain their mean temperature *en route*.

[THE END.]

## The Influence of Gravity upon The Pendulum.

(THE VALUE OF  $g$ .)

IN THE formulas on the laws of the pendulum, the action of gravity is designated by  $g$ ;  $g$  is so extremely important for determining the duration of the oscillation of the pendulum that nothing better has been found than the pendulum itself for measuring its value.

Scientists have for some time been engaged in verifying old and the new data, and the astronomers of war, the officers charged with geodesy, are studying the best means for solving this very delicate problem. Papers on the question are invited, and the subject is of such importance to the watchmakers that we may be pardoned for publishing a note on the subject.

We do not pretend to enter deeply into the matter, and simply desire, while rehearsing what has been accomplished in the premises, to show the difficulties encountered.

The influence of gravity is not the same at the equator and at the terrestrial poles. The flattening of the globe at the poles naturally places the latter nearer to its center. This influence being stronger at the center than at the circumference, or, in other words, this influence, according to a certain law, being proportionately inverse to the distance from the center, it will be understood that if we had the exact value of  $g$  between different stations placed from the pole to the equator we would have the exact form of the earth.

The watchmaker is chiefly interested in the fact that a pendulum regulated at Paris advances at the poles and retards at the equator. We will only cite a few stations and say that the length of the simple pendulum reduced to sea level and oscillating in vacuum is at

|                       |                      |
|-----------------------|----------------------|
| Spitzberg, 996.03 mm. | Bordeaux, 993.45 mm. |
| London, 994.12 mm.    | New York, 993.15 mm. |
| Dunkirk, 994.08 mm.   | Trinidad, 991.06 mm. |
| Paris, 993.90 mm.     | Maranham, 990.89 mm. |

Between the first and last of these stations there is a difference of about 5 millimeters, which represents a difference of time of nearly 4 minutes per day due to the difference of the value of  $g$ .

This  $g$  must consequently be of interest to us, and the processes employed for evolving it therefore require the highest exactness which our more astute confreres have been able to find in their art. In this determination a relative and an absolute value are distinguished.

Let us first rapidly examine the relative value. Its solution is very simple and an approximation suffices.

A good pendulum clock, transported from the pole to the equator, suffices, and it is only necessary to measure the quantity by which the pendulum must be shortened when carried toward the equator so that it preserves its mean rate. The micrometer screw of the pendulum complies with all the requirements desired for ascertaining these differences of length.

It has been proposed lately to employ a column of mercury, acting similarly as a closed syphon barometer upon a gas, the elasticity of which would yield under the influence, more or less large, of the value of  $g$ .

It has also been proposed to weigh a certain bulk by means of a spring preserved at the same temperature. But the physicists decidedly object to the use of the springs, urging that the molecular change of the metal influences the results.

The watchmakers have been more audacious in this regard. They explained to the physicists that they know how to manufacture springs that make thirty-five millions of large vibrations in three months and continue this for years without deterioration.

But to arrive at the absolute value of  $g$ .

All that is required by the calculator to deduct the value of  $g$ , is to have a pendulum which approaches as nearly as possible to a simple mathematical pendulum, to measure its length and to count the number of its oscillations in a given time.

A small platinum ball attached to a cocoon thread, and this thread attached to a knife suspension operating upon an agate surface, and we have the simple pendulum, such as was employed by Borda and afterward by Biot and Arago. But the mass of platinum must be homogeneous, and the knife suspension must be in a state of equilibrium so that it will oscillate of its own accord, in nearly the same rhythm as that produced by the simple pendulum. It is obvious that these experiments are to be conducted in the same state of temperature and moisture of the surrounding air.

The difficulties of this process consist of the resistance of the knife of the suspension on the agate, which is of an unknown quantity, and which may vary greatly according to the good or bad state of perfection of the sharp edge; of the trembling of the supports of the suspension which astonishes all those who witness it; of the resistance of the air, which, it is true, can be calculated, and, finally,

of the process employed for measuring the length of the pendulum under experiments.

The degree of the sensitiveness of these experiments will be readily understood when it is known that it becomes necessary to take into consideration the changes occurring in the graduated rod, according to whether it is horizontal, or sustained vertically upon its foot or suspended by its upper part. Thus, a metallic pendulum is not considered as being of the same length suspended or vertical. The pendulum, called the reversible, is also used with success. This kind has two knives, one of which is definitely attached, while the other is movable in the direction of the pendulum's length, and the latter knife is changed until it is established by experiment that the apparatus, oscillating either upon the one or the other knife, makes the same number of oscillations in a given time, and it is then only necessary to measure the distance between the two knives to obtain the length of the pendulum from which is deduced the value of  $g$ .

This procedure, apparently so simple, leaves room for doubts to the experimenter. It requires supports of an enormous strength to prevent tremblings of the suspension. The apparatus being necessarily heavier than the simple pendulum of Borda, it may well be asked whether the knives do not alter the real value of the time of oscillations. It requires extraordinary care to avoid the deviations produced by the variations of temperature.

Bessel afterward used a simple rod provided with two knives in the same direction, the one at the extremity of the rod the other at its upper third. When experiments had established the number of oscillations rendered by the two suspensions, he applied calculation to define the results, and this is a procedure which to us appears the most preferable.

It is necessary next, whatever be the method of experiment employed, to count the number of oscillations.

No escapement charged with entertaining and counting the vibrations can be employed. The action of the escapement would alter the theoretical durations of the latter, and it becomes necessary to count them one by one with all possible care. It is also obvious that the arcs of vibration must be very small, otherwise the duration of each beat would insensibly diminish.

Watchmakers know well that this duration does not vary, no matter what be the extent of the arc passed through, provided these arcs do not extend beyond two or three degrees.

For counting the number of vibrations the method called coincidence is used.

The pendulum under experiment is placed in sight of another one of a standard regulator, and as the duration of their oscillations are not exactly the same, they will coincide only after a certain number of beats which are counted for the first time. The same number of beats, are reproduced at each coincidence, and it suffices to multiply the number of coincidences observed with the number of oscillations counted to obtain the necessary data.

To sum up: The necessary points to be observed are: To construct a pendulum the length of which is easily measured and the suspension of which is uninfluenced by the mass, its resistance and its frictions, and to count its oscillations without causing any alteration whatever of its rate.—[*Revue Chronométrique*.]

---

### Practical Science.

THE PROLONGED period of rainy and cloudy weather, which happily seems now at an end, furnished an excellent opportunity for those few photographers in this vicinity who have gone to the expense of electric lighting installations for a fair trial of their new apparatus. Contrary to the predictions of the wisecracks who predicted failure, the electric light has proved an unqualified success in photographic studios, and the writer, who recently visited one of these, was told that the electric light, if properly arranged, was superior to sunlight for taking photographs, beside being far more reliable.



While many people were turned away from the sunlight photographers and told to wait for a "white" day, their brethren having electric light studios had their hands full of work, in some cases taking pictures up to midnight; for by the electric light pictures can be taken as well by night as by day.

It is openly claimed that better pictures can be taken by the artificial than by the natural light, and in the studios where electricity is used, whether the sun is shining brightly or not, the best pictures are reserved for the electric light. The reproduction of cuts and pictures already printed is now done entirely by means of the electric light, and plates can readily be got ready in this way in twelve hours from the time the foreign papers reach this port.

The German press is enthusiastic over the experiments now being made at the Philharmonic Society's office in Berlin, which has been put in such perfect telephonic communication with the distant opera house that the effect of the music is reproduced without the loss or slurring of a single note, even of a Wagner composition. The music is dampened and it sounds as if the orchestra were separated only by a thin wall from the listeners holding the telephonic receivers to their ears. Listening to one act of "Tannhauser," a listener says that before the orchestra commenced playing the voices of the audience could be heard, the tuning of instruments and the noise caused by the chairs being dropped to seat the audience.

Herr von Perfall, the manager of the theatre at Munich, had a telephone line built to his villa at Tutzingen, on the Starnberger Sea, and there he not only listens to a play but also to the public applause. A very curious experiment was recently tried with great success. Connecting the Tutzing villa of Manager Perfall with Munich and Oberammergau, the length of the line being ninety-five kilometers—about fifty-four miles. In Oberammergau, where the pupils of the school were rehearsing for the "Passion" play, the songs and talking were plainly heard. During the day the teacher spoke to the people in Munich or played for them on the piano or violin. In the evening the actors met the teachers and sang, the voices being distinctly heard.

At Tutzingen, at the house of the inspector of the glass palace, the inspector's wife was stationed at the telephone. From Munich her husband asked her to take part in a song, the different voices comprising which to come from Munich, Oberammergau and Tutzingen. First it was a solo from Tutzingen, then a duet between Tutzingen and Oberammergau, and finally a trio between Tutzingen, Munich and Oberammergau.

This is, of course, not at all astonishing to us here in America, so far as the telephone is concerned, for we have recently seen that conversation and music can be heard between New York and Chicago—one thousand miles distant—and many of the telephone exchanges throughout the country think nothing of coupling up a series of towns fifty or even one hundred miles apart; but, owing to the fact that the telephone is a huge monopoly here, all the advantages of having the opera brought to the house by wire and other various conveniences, which special telephonic service is capable of, are not yet within our reach.

A process has recently been discovered for effectively cleansing old paintings without doing them any injury or requiring the retouching process after being used. The dust is first removed with a brush, the picture being then washed with pure water. After this the surface of the picture is covered with a thick layer of soap, which is removed after eight or ten minutes by a hard brush and water. After the last traces of soap have disappeared the picture is thoroughly dried and rubbed with linen rags dipped in nitro benzine. The cleansing is complete when the rags cease to be soiled. After again drying, the painting is covered with fine olive oil and varnished.

No amount of warning and precaution is, it seems, sufficient to prevent visitors to the electric lighting stations here and throughout the country from going near the magnets with their watches. The result is that many people are now provided with magnetized watches,

some of which will go for a short time and stop, while others seem to have acquired this or that peculiarity which makes them little better than worthless. The strength of these magnets is so great that when a lady approaches too close the hair pins will with one accord fly from her hair and tenaciously adhere to the magnets, for which they have, naturally, a strong affiliation. A learned professor, while going to examine some powerful electrical machines recently, took his watch with him by mistake. The result, as may be imagined, was by no means improving to the watch, a fine chronometer. He found subsequently that the losing rate was several minutes a day; but that it varied with the position or azimuth of the watch. The fact suggested to him the feasibility of constructing an integrating chronometer which would give the mean course of a ship during her voyage. Examination of the works showed that the watch was magnetized in the bar of the balance and in some screws. He attributed the change of rate in the magnetized watch to these causes, and also, perhaps, to magnetization of the hair spring and the induction effect of the moving bar on the metal case. He had the watch refitted with a gold spring and platinum silver balance, but while free from magnetization the least shock, he says, is apt to distort the balance. He has had it fitted with a platinum-iridium balance, and the watch is now so non-magnetizable in its renovated condition that it may be placed with impunity on the pole of a dynamo.

At the recent Vienna Electrical Exhibition soft iron cases were sold as magnetic shields for watches, and are said to have answered the purpose; but some definite and reliable tests are wanted to assure the scientific faculty of their efficiency.

One of the neatest and most generally useful electrical mechanisms recently introduced is a little motor for running sewing machines. There is absolutely nothing new about this save the general introduction at reasonable figures. These little motors may be run with the same power that would be required to keep an incandescent lamp of 16 candle power aglow—equal to an ordinary gas burner in intensity. They may be run by a battery or directly from either arc or incandescent light wires. In an office in New York city there are several sewing machines, a blower and a printing press driven by these little motors, the current being furnished by an arc light wire from the street circuit. Each motor is furnished with a resistance box by which the strength of the current or the amount of it used may be graduated to the requirements of the work being done. By means of a switch in this assistance box connected with the treadle of the sewing machine, the machine may be started or stopped or run at any speed from a few stitches per minute up to any rate the machine will stand without flying to pieces.

The great question as to just what electricity is has not yet been decided, even by those learned men who devote themselves entirely to the contemplation of abstract or purely scientific questions. A popular belief, however, is now current that electricity is a mechanical vibration, and it must be acknowledged that there is much evidence in support of this theory. When water and carbonic acid are produced by combustion, chemical affinity has been shown to be an expansive force. Non-chemical action, also, causes an expanse in the combustion of iron or zinc with oxygen, for the oxides of iron and zinc are less dense than the metals, and, although the alteration in bulk is very little, the force required to produce it is, in comparison, very great, whether estimated by the heat obtained during the change from metal to oxide, or by the cohesion which is overcome. But there is a movement of oxygen as well as metal, and the oxygen must of necessity move faster than the metal, because it condenses from a gas to a solid, while the metal remains a solid and almost without motion; and, having regard to the combining weight, the momentum of the slow movement of the zinc will be overcome by the rapid movement of the oxygen, which will, therefore, give the most powerful mechanical effect. Again, when oxygen unites with hydrogen it moves into double its ordinary bulk, while the volume of hydrogen remains constant, so that, in this case as well, the oxygen is still the moving and consequently active mechanical agent.

It has also been experimentally determined that the amount of oxygen or of a similar substance, and not the metal, determines the amount of electricity in the galvanic action. Water and some other liquids are, as is well known, mechanically carried through non-conducting porous substances by galvanic action, and, when water is mechanically forced through such substances, galvanic action is produced. Mechanical force and galvanic action have been found, therefore, to be directly convertible.

Dr. Lighthill's recent experiments with his indicator for locating veins of minerals in the earth has attracted considerable attention. The experiments were entirely satisfactory. Following the extension of a vein of one already opened for a time, it was found that for a distance of seventy feet the course of the vein was somewhat curved and varied in width from four to seven feet. When the electrodes or needles were pushed into the ground over the vein and the key of the galvanometer opened, the needles of that little instrument revolved with greater or less rapidity, as the inventor explained, according to the depth of the vein under the surface. On the extreme edge of the vein the development of energy in the needle of the galvanometer plainly indicated the presence of a ground current, and that the circuit was completed, else there would have been no motion on the part of the indicator. Upon pushing the electrodes into the ground at a distance of one inch from the extreme point where the galvanometer last demonstrated the presence of a ground current, no motion whatever on the part of the needle or indicator in the galvanometer was noticeable. This, the inventor claimed, indicated that the extreme edge of the vein had been passed. Experiments at a point exactly four feet opposite showed the same result. Experiments were then carried on in a straight line for a distance of 100 feet away from any known vein. In some places the galvanometer manifested the presence of a ground current, and in others not the slightest movement of the indicator could be brought about even by replenishing the batteries of the appliance with fresh battery fluid. At one spot where evidences of ground currents of electricity were particularly strong the points of the electrodes were pushed into the ground lengthwise with the vein and then crosswise with it. The result was that when the electrodes were pushed into the ground crosswise the indicator in the galvanometer spun around with such rapidity that it could not be seen, whereas when it was placed in position lengthwise the vein of the needle revolved at a mere nominal rate of speed. The cause of this is yet to be explained, although one gentleman present claimed that it was the result of the several metals which might compose the vein.

Earth tremors produced by artificial disturbances, such as the passing of carriages or trains, the movement of machinery or bodies of people, are at our disposal for daily observation. At Greenwich Observatory the tremulous motion in the soil, especially noticeable on bank holidays and at all times when Greenwich Park was unusually crowded, resulted in the construction of an apparatus in which the dish of mercury used in the determination of the collimation error of the transit circle was suspended by flaccid springs. By means of this contrivance the tremulous motions of the ground were absorbed before they reached the mercury, and the difficulty of observation was overcome. French engineers, working with delicate surveying instruments in crowded cities, have similarly been compelled to suspend a portion of their apparatus so that a steady image could be obtained. Prof. H. M. Paul, seeking for a site for the Naval Observatory at Washington, found that the image of a star reflected from a tray of mercury was disturbed by a train passing at the distance of a mile. Lieut.-Col. Palmer, when engaged in observing the transit of Venus in New Zealand, discovered that a ditch a few feet in depth was sufficient to intrench his instruments against the disturbance created by trains passing at a distance of 700 yards. Capt. Denman found the effect of a goods train to be transmitted 1,100 feet over marshy ground, but vertically above the train, passing through a tunnel in sandstone, the disturbance extended only

100 feet. One result obtained from these and numerous other observations upon artificially produced tremors indicates that these disturbances are superficial, and although they may creep up the surface of a gently sloping hill, their spread is checked by a steep cutting.

Bog oak, which the chemical action of the peat water renders perfectly black, is very rarely obtained in a sound state, and in most cases the outer portions of the tree or log are rotten and useless even for fuel purposes. When laid up for use, care must be taken that it is not placed in the open air lest it may, from the sun's rays, become open and shattered into chips from end to end. To preserve it, it must be put into some cool place and left to dry gradually, and when properly seasoned it must be cut in lengths of from two to four feet, and these lengths be split again and the sound parts removed from the unsound. It takes from four to six years to season some specimens, as in many instances the wood is found at a depth of eight feet and sometimes ten feet under the surface. The finish is not quite perfect until the article has been for some time in use, and the longer the finer the article seems to be, no matter whether used as a personal or table ornament.

---

### Invention of Scales.

"The Eternal hung forth his golden scales,  
Wherein all things created first he weighed."

In the ancient Egyptian belief the hearts of all the dead were weighed before Osiris in the Hall of Perfect Justice, and a papyrus representing the ritual for the dead, preserved in the British Museum, pictures the ceremony of the weighing "for good or evil," and incidentally affords an excellent view of the scales of early Egypt. In these scales the balance-beam is neither suspended by the center, as in the modern form, nor after the manner of the steelyard, but is arranged with a shifting fulcrum, the adjustment of which shows the difference between the weights of two objects. The weights used were of metal in the form of rings, and it may be said in general that this was the prevailing type of all early weights. These scales, it will be observed, are by no means of the simplest form, or that which would naturally first suggest itself to mankind, and this fact argues the employment and gradual improvement of weighing apparatus long anterior to the date of this papyrus (1350 B. C.) We have no knowledge of their earliest invention or forms. The discovery of their uses has been attributed to many geniuses, and doubtless with something of truth in the individual cases. Pliny credits them to Phidon of Argos, Gellius says that Palamedes invented them, and a host of writers following in their wake, each crowns his own particular inventor with the honor. Among others—

"Juno pours out the Urn, and Vulcan claims  
The scales as the just product of his flames."

But certain it is that they have been known and employed from time immemorial. Their known existence, however, dates back very far, and puts to the blush the fictitious origins attributed to them. When, in 1860 B. C., Abraham weighed out 400 shekels of silver as the consideration for the first real estate transfer of which history makes mention, he used them, and they are frequently referred to in the Bible, in Zachariah, Leviticus, &c. The earliest scales were temporary, simply a beam balanced in a stirrup, the weights being arbitrary and varied, though, as above stated, usually in the form of metal rings. In ancient Egypt they were strictly under the superintendence of the priesthood, and so continued until that people came under the Roman sway. They were kept in the public markets, as was also the practice in Greece and modern Egypt. The larger scales were constructed on the same principle of the beam and stirrup, with the addition of a flat board or platform suspended from each end of the beam by four ropes or chains.

In all scales accuracy and the quality of turning under the slight-

est possible inequality in balancing weights are the highest desiderata, and so great has been the perfection obtained by means of knife edges and agate planes, in some of the finer scales, that the declaration to Shylock that

... "If the scale turn  
But in the estimation of a hair,  
Thou diest,"

would be robbed of its terror. The English mint is said to possess a scale which turns at a 1-9,000,000 of the weighing capacity.

In all ages the scales have been the emblems of justice, and it is to be hoped that the latter has kept pace with the improvements of its emblem.—*Call Smith, in the Industrial World.*

## Proceedings of the Horological Club.

### A DISTINGUISHED BODY OF WATCH AND CLOCK MAKERS.

*One hundred and twentieth discussion.—Communicated by the Secretary.*

[NOTICE.—Correspondents should write all letters intended for the Club separate from any other business matters, and headed "Secretary of the Horological Club." Direct the envelope to D. H. Hopkinson, Esq. Write only on one side of the paper, state the points briefly, mail as early as possible, as it must be received here *not later* than the eighth day of the month, in order to be discussed and reported in the CIRCULAR for the next month.

#### MOTION WORKS FOR ELECTRIC DIALS.

*Secretary of Horological Club:*

In your last August Proceedings, Mr. J. H. S. had a short item on electric dials. I have one made all but the dial wheels. I have a center arbor with second hand attached as he suggested; now, how am I to get my minute hand and hour hand to work with the second hand? How many teeth in each wheel and how many leaves in each pinion? Please explain. C. E. F.

Mr. McFuzee said that the device described in our August Proceedings did not have an arbor for seconds hands, but was for carrying a minute hand. The motion wheels for also moving the hour hand were placed between the main plate and the small plate indicated by the dotted lines in this cut, and could be such as were to be found in any clock movement—thus saving the trouble and expense of making them.

If Mr. F. really employs the device to operate a seconds hand on his dial (which is very rarely done, however, in such clocks), his cheapest way would be to take a cheap clock movement which has a seconds hand, and use that train of gearing to connect the seconds hand to the hour hand. The magnet would move the ratchet wheel (which should be fastened on the arbor of the seconds hand, and the wheels and pinions of the clock from that arbor up to the center arbor would do the rest. Only in this case the train would work backward, *i. e.*, instead of the wheels driving the pinions and turning the seconds hand arbor, the pinions would drive the wheels, working in the reverse direction up to the center wheel. Another way would be to make another electro-magnetic device to operate the center or minute hand arbor, directly from the governing clock, and work the hour hand from that by the usual motion wheels of clocks.

BROKEN MAINSPRINGS.—HOW MUCH IS MEANT BY WATCH COMPANIES IN CALLING MOVEMENTS "ADJUSTED."

*Secretary of Horological Club:*

As I see you invite correspondence from persons interested in the watch and jewelry business, I will take the liberty to ask a few questions. First, I would like to know whether the watchmakers in different parts of the country had met with an unusual number of broken mainsprings during the month of February last? I am quite sure that I did, and I wondered whether it was only accidental or whether it resulted from some natural cause that produced the same effects in other places. I send you herewith a wax impression of one as I found it in the barrel, broken into 14 pieces. Second, I should also like to know just what is meant by the expressions

"adjusted to temperature" and "adjusted to position," which are so frequently used these days in regard to the watches we buy and sell. As there is no perfection in these matters, it must, of course, all be a question of approximation; and what I would like to know is where do they draw the line? If a watch with an expansion balance is subjected to a test in two different temperatures, and one pair of the balance screws is changed in the direction to bring it to a more uniform rate, it may, in a sense, be said to have been adjusted to temperature. So a watch in which the balance has been carefully poised may be said to have been adjusted to position.

But this is indefinite. Prof. Waldo tells us to what standard it is necessary for a watch to come in order to receive his certificate. This was an interesting item of information to me, but I am more interested to learn to what standards of accuracy the numerous adjusted watches that are being put on the market at this time are brought. Perhaps some more fortunate members of the craft may be in possession of this information and will kindly furnish it. If not, I think that if some of the watch manufacturing companies would enlighten us in regard to what we might safely claim for the watches they are stamping "adjusted," the information would be thankfully received. C.

None of the members had observed any noticeable change in the number of broken mainsprings during February, but the publication of Mr. C.'s letter will doubtless bring out the fact if it has occurred in other sections of the country. It is thought by many, said Mr. Isochronal, that these periods of numerous breakages are caused by electrical changes either in the atmosphere or earth. If so, they should be noticed at different places on the same day. But observations should be confined to shorter times than a month. Electrical changes would not take more than a day or two—or a week at most—and, if they cause the breakages, the repair books should locate them almost to a day. Possibly there was some uncommonly cold weather or sudden changes during February in the neighborhood of our correspondent, in Vermont, and that may be the cause. As regards breaking in fourteen pieces, we have had instances given where they had broken into more than twenty pieces with the ends of all the pieces in a line, in the same way as shown by the impression sent us by Mr. C.

Mr. C.'s second question is unanswerable. No one knows, outside of the factory or workshop, what standard of performance each company sets up or how closely they adhere to it if they have any. As makers are not able or disposed to give any information or guarantee any particular degree of adjustment, the only course is for dealers to test the watches for themselves and see what they are good for. We quite agree with our correspondent that it would be very desirable to have some statement from manufacturers as to what they *claimed* their adjusted watches would do, and think they would gain customers by giving such statements.

#### HOW TO MOVE THE HANDS OF A WATCH SIGN.

*Secretary of Horological Club:*

As "Staib's Street Watch Sign" seems to be shrouded in mystery, will you permit me to describe an easy and practical way of working the hands of such a sign. A method I used years ago to work the hands of a transparent dial in my shop window, and which can be applied to such a sign as Mr. Staib's.

Turn two brass collets of precisely the same size. Fit one on the center arbor of a timepiece and the other on an arbor which is to carry the minute hand of the sign. To this arbor fit a set of motion wheels in any of the ordinary ways, and fasten them in a frame to the back of the face of the sign bringing the arbor fair in the center. The hands of the sign should be nicely counterpoised. Beside this you require a small weight and pulley, the weight of which depends on the size and weight of the hands of the sign, ranging, say, from 5 dwt. to an ounce or so. This completes the arrangement. Now place the sign and timepiece in position. Pass a silken cord round the collet on the center arbor of the timepiece, then through the pulley of the little weight, then round the arbor once more, then extend it to the collet on the sign round which you pass it twice and knot the ends of the cord together. It will be seen that the object of the little weight is to keep the traction of the cord even and constant. Allow it to hang a few inches, and for this reason a drop octagon timepiece is the best of common clocks for this purpose, having plenty of room inside the case. It matters little if the timepiece is above, below or on either side of the sign. If your sign is to have two faces like Staib's, you must have two collets on the

arbor of the timepiece and a set of motion wheels, etc., for each face, and as the hands of the sign must go in opposite directions, one of the belts leading from the timepiece must be crossed and the other not. With the parts all nicely made no trouble will be found in obtaining the desired object. I may add that the grooves in the collets should be a bit flat on the bottom to prevent the cord from crowding and riding, and use cord that is not fuzzy, and that, I am sorry to say, is not easy to get. Yours truly, MYER MOSS.

Mr. Uhrmacher said the idea of Mr. Moss was an excellent one and very ingenious. For the cord he would suggest a small silk fish line. They could be got of small size, braided very closely and very limber, and the most durable of anything he knew for such purposes. The ends should be spliced in such a way as to avoid a lump as much as possible. He regretted that Mr. Staib had not seen fit to explain how the hands of his sign were operated, but thought that the device of Mr. Moss would work as well as could be desired. We should be pleased to hear from him again, and also from any other reader who can suggest an easy and effective method for securing the desired end.

#### LAPS FOR ROTTEN STONE.

*Secretary of Horological Club:*

In a recent number of THE CIRCULAR it says to use rotten stone and water on laps for polishing pallet stones, but it gives no mention about the lap and it tells to refer to the back numbers. What I mean by the lap is that I don't know whether to use a copper, zinc or boxwood. I'd be much obliged to you if you could accommodate me with my request. Trusting to hear from you soon, I am  
J. L.

Mr. Lapidary replied that copper could be used for laps with nearly all grinding and polishing materials, from diamond dust to rouge and lime. An old copper penny solidly screwed upon a center arbor or mandrel—which is better than riveting or soldering—makes a good lap, as the coining process has hardened the metal, so that it will keep its shape and wear well. Many workmen use type metal, others block tin and even iron. But there was no better material than tough, close grained, hammer-hardened copper. The face and edge are first turned off—the face quite flat—then stoned down with a piece of Scotch gray stone and thoroughly washed. Each lap should be used for one kind of powder only, and care must be taken to avoid mixing the different powders either on the lap or elsewhere. If different grades of the same powder are used, they, too, should be kept separate. Stones may first be shaped with a diamond-dust lap, smoothed with fine emery and water and polished with rotten stone and water. These laps and powders will cut and polish any ordinary stones, such as amethyst, chrysolite, garnet, onyx, quartz, agates, rock crystals, etc. Glass and soft stones are usually polished with putty powder or oxide of tin. Tripoli is also often used for soft stones, and block tin laps are hard enough for that kind of work.

#### WAGER ABOUT CLOCK WEIGHTS.

*Secretary of Horological Club:*

I hope I am not too late to ask a question through your journal. Will you please answer the following question: Which weight on these large 8 day English hall clocks should go on the striking side, providing the one weight is heavier than the other, as I have repeatedly found them? I ask this question to decide a bet, and to know if I am wrong or not. By answering the above question you will oblige  
K.

Mr. Ball (J.) said his rule was to require the stakes to be put in his hands as a condition precedent to deciding a bet. This was simply to insure good faith on the part of the disputants, so that if neither party should call for the money it would not go to waste.

In this case, however, he would waive these requirements for the time being, and render an interlocutory decision, *pro tempore*—after the manner of an *amicus curiae*, so to speak—subject to appeal if either party should feel aggrieved. His decision was that in the case set forth and according to the evidence adduced, it was immaterial on which side the heavy weight went or whether it went on either side. It had not been shown that any weight was required;

therefore, it could not logically be claimed that a heavy weight or any other weight, "should," or must, or ought to go on either side. It was accordingly adjudged that neither party had acquired any legal claim to the amounts wagered, and they should, within 30 days, deposit the same with the referee to await further proceedings in this case, and until a final decision should be reached.

#### ENAMELING GOLD JEWELRY.

*Secretary of Horological Club:*

Will you please inform me how to *prepare work* for enameling (how to clean it and what precautions to take, etc.), and if 10-karat gold can be enameled and make a good job of it. R.

Mr. Rolliver replied whatever the design is you want enameled must be cut by an engraver. After he is through with it, the enameLER will do the rest. All that is necessary to clean the article is to boil it in a weak solution of sulphuric acid and water. 10-karat gold can be enameled in black as well as any other karat. Bright colors do not come out as well.

#### SNYDER'S ADJUSTABLE CHUCK.

Mr. Clerkenwell then called the attention of the Club to a new adjustable chuck for holding watch bezels, wheels, plates, barrels, pinions, etc. It has six segments or jaws sliding in ways to and from the center, all moved at once by a single milled nut behind, which should preferably be made of steel. The jaws act both on the stop principle and as self-centering clamps, and hold the work from either inside or outside, from a small drill or pinion up to a large watch bezel. It can be fitted to any lathe by the workman by turning a taper to fit the inside of this chuck, upon a mandrel or plain chuck fitting into the lathe spindle. Or, any maker of American lathes will now make a mandrel chuck fitting both the latter and this chuck for \$1.50. He believed the price of the chuck was \$8, and it was made by the patentee, Mr. S. I. Snyder, Clearfield, Pa., who would furnish any desired information. It seemed to be adapted for a wide range of work, and would doubtless be found a valuable addition to the watch repairer's stock of lathe attachments, as it is easily operated and holds the work very securely.

#### HOW THE SIZES OF WATCH MOVEMENTS ARE MEASURED.

Mr. McFuzee then observed that one of our correspondents had written to inquire the meaning of the "sizes" of watch movements. The inquiry was on a postal card which had been handed to him to answer, but by some means the card had been mislaid and could not be found. He would answer the question, hoping that the inquirer would see it the same as if his name and letter had been printed with the answer.

There are four different methods of expressing the sizes of movements. The French and Swiss measure across the dial and give its diameter either in millimeters or in French lines. A millimeter is about four one-hundredths ( $\frac{4}{100}$ ) of an inch; or, more accurately expressed in decimals, 0.03937 inch. A French line is about nine one-hundredths ( $\frac{9}{100}$ ) of an inch, or, in decimals, 0.0888 inch.

English movements are sized by what is called the Lancashire Movement Gauge, which is a three inch measure. The sizes begin with one inch, *i. e.*, a movement 1 inch in diameter is size 0. The sizes differ by one-thirtieth ( $\frac{1}{30}$ ) of an inch. Size 16 English would, therefore, be  $1\frac{16}{30}$  inch in diameter, and so on. But it must be remembered that English sizes refer to the diameter of the pillar plate of the movement, not that of the dial. As everybody knows, the dial of an English watch is considerably larger than the movement, to allow the dial plate to rest upon the watch case, while the movement goes inside of the case and is supported in its place by the dial plate—the movement itself not being allowed to touch the case. The dial is five sizes larger than the movement; so a 16 size English watch would have a dial  $1\frac{21}{30}$  inch in diameter, or, in decimals, 1.700 inch. A French or Swiss watch having approximately the same size of dial would be called a 19 line watch or a 43 millimeter watch. The American movements are sized by the Lancashire gauge, only omitting the allowance of five sizes between the movement and the dial—measuring the dial itself to get the size of the watch.

PROTECTING WATCHES FROM ELECTRICITY AND MAGNETISM.—  
IGNORANCE VERSUS HUMBUG.

Secretary of Horological Club:

I clip the following article from a Chicago paper. Is it possible that all the writer claims in it can be true? I have frequently had watches to put in order that would try the patience of Job; they would act in an unaccountable manner; and I thought I knew considerable about watches, too. The above theory may explain the trouble. But the remedy. He is claiming much when he claims to control electricity and magnetism, and says "Hitherto shall thou come but no farther." "Joshua commanded the sun to stand still" and it did so. Can any of the modern prophets do it? Perhaps the magnetic arrester is a sort of "Keely motor." But if it is what is claimed every watchmaker will want one, for there is not one who has not used some "swear words" regarding the freaks of watches. Please give us your opinion and *draw out* the watchmakers on this point. I think there is more or less humbug in the matter; anyway I wish to be convinced.

PITMAN.

## NEW DISCOVERY.

The "adjustment" of any watch is entirely valueless in the presence of magnetism. Electric and magnetic currents have a much greater effect on the rate of a watch than either "temperature" or "position." It is asserted—with strong proof to back it—that electricity and magnetism are the direct causes of the "queer and unaccountable freaks of watches" which have annoyed and baffled the skill of the very best workmen, and is the secret enemy which has frequently undermined their reputation as skillful watchmakers. No "adjustment" however nice, no workmanship and "finish" however fine, will withstand for a moment the magnetic influence; in fact, the finer the watch the more susceptible it is. And it is frequently the case that the cheaper unadjusted movement keeps better time than the fine adjusted movement. The metals composing the "compensation" balance form a sort of mild battery which is intensified by the magnetic influences, either personal or mechanical, and the close-coiled hair spring attracts and conducts the current, which greatly interferes with its free movement and many other points which might be mentioned, making it plain to the most casual observer that no watch can be absolutely reliable unless it is protected from these magnetic influences. We predict that the future certificates and rulings from horological colleges and the warrantees of watch manufacturers and workmen will read: "Above ratings guaranteed if this watch is protected from magnetic and electric currents."

To show how small a variation in each beat or half revolution of the balance of the watch is necessary to make a considerable difference in time in twenty-four hours, we give the following figures: An ordinary watch beats 5 times a second, 300 times per minute, 18,000 per hour, 432,000 per day. An influence brought to bear on the balance or hair spring to change the revolution  $\frac{1}{100}$  part, would make a variation of about fifteen minutes a day. Below we give a description of a scientific discovery which promises to be of very great importance to horologists and watchmakers; it will render operative the fine adjustments and mechanisms which heretofore have been made almost *nil* and inoperative on account of their susceptibility to the all-pervading magnetic influence.

Mr. Electrode replied that while the remarks upon the injurious effects of magnetism were substantially correct, those referring to electricity were sheer nonsense. The article did not show humbug so much as ignorance. No one who had any knowledge of electricity would make such an ass of himself for the sake of humbugging the public, because he could do just as much humbugging and even more without making himself ridiculous by displaying his ignorance. Under no reasonably supposable circumstances could "the metals composing the compensation balance form a sort of mild battery." And even if they could they are so arranged that the current would complete its circuit within the balance itself; and so far from its effect being injurious, it would be next to impossible, with the finest apparatus known, to detect its presence or its absence. The presence of suppositious electrical currents generated in watches is a bugbear that has frightened the ignorant long enough, and it is about time that the trade should understand that no such currents ever are or ever can be produced in any movement which is in a fit condition to run at all. If it was filled with salt water or some solution of chemical nature, a current would be produced by the oxidation of the parts. But no watch in any ordinary circumstances is capable of producing an appreciable current.

The writer of the article evidently does not know that there is any particular difference between electricity and magnetism, for he first calls it one thing then the other. He also speaks of the mild battery being "intensified by the magnetic influences, either personal or mechanical," etc. Now, neither a battery nor a current can be "intensified" by magnetic influences, *i. e.*, by real magnetism. As for "mechanical" magnetic influences, there is nothing of the kind in existence; and "personal" magnetic influences are of a nature to affect *persons* but not batteries nor watches. It is a favorite delusion with many people that the going of watches is more or less affected by the "personal magnetism" of their owners. There is no doubt that a watch will run differently when carried by different persons. But the difference is due, not to the "personal magnetism" of the persons, but to the difference in their manner of moving about or of taking care of the watch, in their regularity of their habits, or even in the greater or less warmth of their bodies. One lady of sedentary habits may carry a watch in her bosom where it would be kept quite warm and still. Another lady, lively and restless, would carry it as a chatelaine where it would be cool, and would also be shaken, and swung, and jerked, and kicked about every time she moved. There would naturally be a great difference in the performance of the watch according to which lady carried it. But no one but a fool would attribute it to difference in their "personal magnetism." And it is so in every case. Personal magnetism has nothing whatever to do with the performance of the watch; the only influence affecting it "personally" is the difference in its handling or treatment by different persons. Yet there are multitudes of people who are possessed of average common sense in some respects, but who, when it comes to watches, are completely blind to what is directly under their noses, and seek for an explanation in some far-fetched imagination about "personal magnetism." It is this class of crack-brained idiots who enrich the electrical quack doctors, and buy electric belts and shirts, magnetic hair brushes, corsets, medals and other gauzy devices for gulling the credulous and simple, and putting their money into the pockets of those who are better able to take care of it.

The single grain of truth in the article is the fact which everybody knows—that watches are affected by magnetism. Whether the steel parts of the mechanism are themselves magnetized, or are acted upon by magnetized pieces outside, does not matter much, as in either case the watch cannot keep good time. Whether the watch is adjusted or not makes no difference. A fine watch is no more nor less susceptible than any other. The effect depends solely on the strength of the magnetism, and the way in which it acts upon the steel parts of the movement.

Friend Pitman forgot to send the half of the article which describes the "magnetic arrester," but he may rest assured that there is no substance or device known which can stop magnetism. If he will look up that Chicago daily and send us the description of the "magnetic arrester," we will give it a notice that will do it good. Send on the rest of that article, O! Pitman—then see the dust fly!

## Improved Ear Piercer.

IMPROVEMENTS ARE the order of the day, and inventive genius directs its attentions into all the domains of science, from the complicated machinery for making perfumery and packing "limburger kase," to devising delicate engines for piercing ladies' ear-laps without provoking a piercing shriek at the operation. When a valued correspondent last year recommended the use of a "bulldog," powder and ball, and at a distance of 15 or 20 paces perforate said laps, he perhaps recommended the use of unnecessary forcible means. The idea, however, has been seized hold of in military Germany, and slightly modified as accompanying cuts will show. The rage that prevailed among our jewelistic brethren last year on the subject of inventing ear piercers, has fortunately left our shores to

seek new "pastures green" on the other side of the pond. (By the way, the best ear piercer is an attempt to kiss the wrong girl). But a truce to preambles.

The diabolical attempt is protected by letters patent granted by His Imperial Majesty of all the Germanies, and the *Deutsche Uhrmacher Zeitung* says as follows:

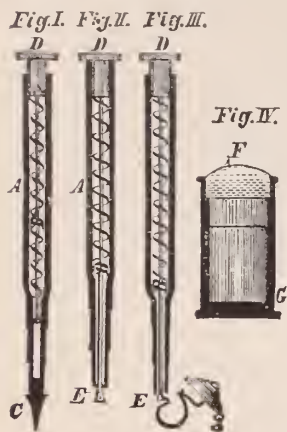

As will be seen by accompanying cuts the apparatus at first consists of the hollow tube *A*, figs. 1, 2 and 3, made of nickel, and next of a bolt *B* within the tube pressed backward by a coiled spring; the fore end of the bolt is perforated and forms a loop *E*, fig. 2; beside this, a loosely inserted gilt point *C*, fig. 1.

The ear-lap is pierced in the operation by placing a capsule, provided with a cork *F*, fig. 4, and accompanying the instrument behind the ear, applying the instrument and exerting a pressure upon the button *D*. The point penetrates through the lap into the cork and remains inclosed in the capsula until wanted again. A second pressure upon the button *D* renders visible the loop *E* in which the ear ring is inserted as shown in fig. 3, and by loosening the pressure is pushed in. When the instrument is drawn back the ear ring is at the same time drawn through the ear-lap, after which the "machine" is laid aside and the ear ring is then closed.

The apparatus is represented in about one third size; the point *C*, as well as the silver tube *E*, must, in practical execution, be made smaller and more conformable to the purpose; in the cuts these several parts have purposely been made larger. In the same way the bolt *B* at the button *D*, fig. 1, must be imagined as prolonged as far as the solid point *E*.

This engine of war has been invented by one of Germany's best watchmakers, F. K. Kaltenthaler.

### Electro-Brass Plating.

MANY ARTICLES of some inferior metallic composition or of low grade alloys may be provided with a brass coating by electric deposition, in order to present a more acceptable appearance. This brass coating can, by this method, also be applied to iron, steel, etc. The composition of the brass, as well as the preparatory and finishing operations, are alike both for brass and for copper deposits. Those who electro-plate coils of iron, composition wire, etc., apply heat for brass deposits, while the baths are generally not heated for other articles. An oblong open iron boiler lined with sheet brass usually contains the hot bath, while the cold plating bath is generally placed in a wooden receptacle, coated with gutta percha or asphaltum. The anodes are of plate or sheet brass joined together and arranged along the sides all connected with the lost carbon or copper of the same battery. The strength of the battery current is regulated by the surface of the articles to be electro-plated. The articles are suspended in the usual way—by copper or brass hooks to stout hooks of the same metal, all connected with the lost zinc of the battery.

*The brass baths.*—When the ordinary cheap commercial cyanide is used, the following answers very well: Sulphate of copper, 4 ounces; sulphate of zinc, from 4 to 5 ounces; water, 1 gallon. Dissolve and precipitate with 30 ounces of carbonate of soda; allow to settle, decant the clear liquid and wash the precipitate several times with fresh water—after as many settlings. To the washed precipitate add: Carbonate of soda, 15 ounces; bi-sulphate of soda, 7½ ounces; water, 1 gallon.

Stir to effect solution of these last two, then stir in ordinary cyanide of potassium until the liquid becomes clear and colorless. Filter if much iron or iron oxide (derived from impure zinc, salt and cyanide) remains suspended in the liquid. An additional half ounce or so of the cyanide improves the conductivity of the solution.

#### COLD BRASS BATH FOR ALL METALS.

|  |         |      |
|--|---------|------|
| Carbonate of copper (recently prepared)..... | ounces, | 3    |
| Carbonate of zinc.....                       | "       | 2    |
| Carbonate of soda.....                       | "       | 4    |
| Bi-sulphate of soda.....                     | "       | 4    |
| Cyanide of potassium (pure).....             | "       | 4    |
| Arsenious acid.....                          | "       | 1/20 |
| Water.....                                   | gallon, | 1    |

Filter if necessary.

#### MANAGEMENT OF THE BATH.

The losses of the bath are to be repaired by the addition of copper and zinc salts (and arsenious acid) dissolved in fresh cyanide and water. The operator determines the requirements from the rapidity of deposit, its condition, color, etc. The difficulty in brass electro-plating, especially with small baths, is in keeping the uniformity of the color of the deposit, as the electro current having to decompose two salts, each offering a different resistance, must, according to its intensity, vary the color and composition of the deposit. A feeble current principally decomposes the copper salt and results in a red deposit; while too great an intensity in the current decomposes the zinc salt too rapidly and the deposit is a white or blueish-white alloy. If the deposit has an earthy or ochereous appearance, or if the liquid is blue or greenish, the solution is deficient in cyanide. When in proper working order the liquor is colorless. If the coating becomes dull and unequal a slight addition of arsenious acid will usually improve it. If the deposit is too red, use more battery power or add more zinc salt; if too white decrease the current or add more copper salt. The specific gravity of the bath may vary from 5° to 12° Beaumé; when it exceeds this latter gravity it should be diluted with fresh water to decrease the electric resistance. If the brass deposit is irregular remove the articles from the bath, rinse, scratch brush and put again into the bath until the color and thickness of the deposit are satisfactory. Scratch brush again, and, if necessary, rinse in hot water, dry in warm white wood sawdust and put in the stove room. The last three operations are indispensable for hollow pieces. In the disposition of the brass-plating bath it is always necessary to have all the articles suspended at about equal distances from the anodes. The bath may be subdivided by several anodes forming partitions, so that each loaded rod is between two anodes. The anodes should always be removed when the bath is not in use. In order that the brass electro-plating of zinc or copper may be lasting the deposit must not be too thin, and must be scratch brushed, washed in lime water and dried in the stove room. Generally from ten to twenty-five minutes' exposure in the bath suffices in ordinary practice to throw on a good coating. Cast and wrought iron, lead and its alloys require a bath richer in the metals than when brass-plating zinc or its alloys. The battery power should also be greater. For lead the bath works better warm (at about 90° F). When once placed in the brass bath articles should not be moved about as there is a tendency under such circumstances to the formation of a red deposit.

In brass-plating wire the hot bath is usually employed. As before mentioned the vessel containing the bath usually consists in an oblong, open iron boiler lined with sheet brass anodes and heated by fire, steam or hot water. A stout copper or brass rod in the direction of the length of the boiler rests upon the edges, from contact with which it is insulated by pieces of rubber tubing. The rod is connected with the zinc pole of the battery. The binding wires are removed from the coil, the wires loosened and the ends bent together in a loop. The wire is then dipped into a pickle of dilute sulphuric acid, and hung upon a stout round wooden peg fastened in the wall so that the coil may be made to rotate easily. After a

scrubbing with wet sharp sand and a hard brush the coil is given a primary coating of copper. It is then suspended to the horizontal rod, where only a part of the coil at a time dips into the solution and receives the deposit; the coil is then turned now and then one-half or one-fourth of its circumference. By dipping the coil entirely into the liquid the operation is not so successful. The wires are washed, dried in sawdust and then, in the stove room, and, lastly, passed through a draw plate to give them the fine polish of true brass wires. The temperature at which the hot bath is commonly used varies between 130° and 140° F.

### "There is Nothing New Under the Sun."

THE VERY humorous statuette which may be seen everywhere, of a barefooted boy drawing a spine from his foot and making a very rueful face at the surgical operation, is a plagiarism of one of the rarest and most beautiful of the smaller art treasures of the world, a Greek bronze copy of the Roman "Spinario," known also as "Le Tireur d'Epine," which was sold in Paris several years ago. This statuette is probably a specimen of Greek art of the fourth century, and the figure as seated is nine and seven-eighth inches in height. It was bought by the firm of Rollin & Feuadent, of Paris, where its exhibition created much sensation in the art world, and was sold for 70,000 francs to Baron Edward de Rothschild, who carried it off while the authorities of the Louvre were debating about buying it, and those of the Berlin Museum were anxious to secure it.

If we remember right, it was found some twenty years ago at the Acropolis, on the site of Sparta, Laconia, and sold for a small sum to one Mr. Merlin, the English Consul at Athens. While on a continental voyage, which included Greece, the Duke of St. Albans saw the work and purchased it for \$1,000. The duke, we believe, afterward sold it again to a member of the Paris firm of Rollin & Feuadent for \$5,000.

The legendary story of the "Spinario" is as follows: A young shepherd, seeing the Latins enter in the night time the Roman territory, ran to the capital to tell the Senate. On the way he got a thorn in his foot but did not stop. He endured the pain on his continued course, and after having delivered his message sat down to extract the thorn. The Senate, in admiration of his heroism and to perpetuate his fame and patriotism, decreed that statues representing him taking out the thorn should be erected to his memory. The seated figure is that of a young man, and as he bends forward to extract the thorn from his left foot, which rests on the right by the knee, the expression of his face and the whole anticipatory shiver seen throughout his body, shows that he knows it will be a painful operation but that he intends to go through with it. The youth's hair are short and the whites of his eyes are of silver.

### Practical Treatise on the Adjustment of a Four-Jewel Cylinder Watch.

[First-Prize Essay by HERMANN HORMANN.]

*Continued from page 104.*

204. After the escapement has been set into order and the balance equiposed, the balance spring is taken in hand. The most scrupulous attention must be paid to its correct position; not alone a well-arranged escapement, but also a well placed balance spring will distinguish a good workman from a botch.

If the spring is adapted to the watch, its layering is best performed upon an underlay either of milk glass or of mother-of-pearl, by means of two pointed and delicate tweezers which should be kept separate for this purpose only.

Tweezers with aluminum bronze points are best suited for this

purpose because the spring is not exposed to the danger of magnetism. Steel tweezers become magnetic frequently after a short use only.

205. If the spring lies funnel-shaped because it is not mounted at proper height on the collet, place it upon a well-tapering and round pointed pegwood and bend the inner first coil either up or down. If the collet is too broad and scrapes above on the bridge, the spring must be taken down and the collet, fastened in a turning arbor, is to be turned shorter. At the same time it is rounded off a little from below so that it can more easily be taken down from the steel.

The center of the collet must coincide exactly with that of the spring, which is best ascertained by revolving the balance with the spring between the points of the double calipers. In this position it must run true and have the appearance as if one coil issued from the other one. In order to effect this the inner coil is to be bent. It must also be parallel to the balance, which is in the same way produced best by bending the inner first coil.

206. The balance spring is then fastened upon the bridge and inspected whether it lies flat; if not, it is to be made so by bending the last coil. Next inspect whether it lies in the circle described by the regulator where this is moved either "fast" or "slow." By repeatedly taking down and bending this coil with the tweezers and point of pegwood, it is to be layered thus that the balance spring lies always free between the curb pins, no matter upon what points they may be. When the balance spring has been laid exactly in the circle, then the center of the collet, if the spring is mounted upon the bridge without the balance, must be exactly above the pivot hole in the bridge. This is effected by bending on the outer coil, but not on the part which passes between the curb pins.

207. If the balance spring stud is placed too far out, or if the spring is too small, drill into the regulator before the first pin still another one, which is also to be placed under the spring closing, and on the spring bend an appropriate place which must not be sharp cornered, however, in order to produce the right circle for the regulator motion.

208. If, however, the spring is too large so that it strikes against the stud, unpin it from the latter and file away one-half upon the opposite side of the hole. Then fasten the stud in the bridge in such a manner that the hole for the fastening of the spring come to the outside, and in this manner increase the room for the spring.

Should it be necessary, also the spring closing must be filed back a little and another pin drilled in.

An unduly large spring, however, which strikes on the stud as well as on the center wheel, and which cannot be laid over or under the center wheel, must unconditionally be replaced by a smaller one.

209. To prevent the spring from rubbing upon the bottom of the spring closing, the latter must be sufficiently high that the limb of the balance can just clear it, together with a minimum quantity of space for the sake of insuring certainty. Too short a spring closing, as well as too short a balance spring buckle, which is not provided with a projection, is to be replaced by a better one.

210. Suitable fraises are used for making the balance spring buckle. Another equally good method for making one is as follows: A shoulder file with cut, about No. 5, is annealed that it can be drilled. Varying sizes of holes are drilled into it, of such dimensions as to correspond with the general size of the balance spring buckles. Different sized holes of a diameter of the breadth of the buckles are also drilled in.

211. A suitable piece of brass upon which a screw collet is fastened is then taken, the filed-on center is placed in a suitable one of the large holes, and the breadth of the buckle with the closing above is fraised in this manner. The buckle may then be filed flat approximately upon both sides, and a suitable pivot is then to be fraised on for riveting.

As gauge for the height of the balance spring buckle serves a pin of appropriate length previously inserted in the regulator, which reaches almost down to the shank of the balance. When the buckle

is ready fraised and filed, it is riveted and separated from the main piece of brass with a piercing saw and filed flat above.

212. Every balance spring buckle is to be provided with a slit so that it can be turned with the screw driver; this is also applicable to the balance stud. The projection of the closing must end at the curb pin, otherwise the second coil of the spring can easily entangle in it. The spring must not be pinched between the curb pin and the sharp edge of the spring closing, but must have a shake equal to three thicknesses of the spring blade, and the pin is to be filed sufficiently thin that the second coil of the spring does not touch it.

213. The regulator must be movable with gentle friction. If it moves too hard it may be eased a little by turning, in case the cap jewel plate is soft enough to permit it. Should both parts be too hard, however, the latter is placed upon a turning arbor and ground, together with the regulator, upon the lathe, by applying oilstone powder and oil to both parts, with the left hand holding the regulator and with the right hand driving the bow so as to give a rotary motion to the plate. By frequent cleaning with benzine and fitting in a satisfactory looseness may be finally effected.

214. But the best motion is obtained by a springing friction, by opening the regulator. For this purpose place it with its upper side upon the edge of an anvil, take a cold chisel especially made for this kind of work (it may be shaped like a screwdriver, be tempered and annealed yellow), and set it near the balance spring buckle upon the rounding; the place is first to be prepared by a little filing with the screw head file. A few slight taps are sufficient to produce the desired opening. The smoothness of the opening will increase with the hardness of the regulator. Before the repairer undertakes the opening of the latter without any previous experience, it is advisable for him to try that it be not too hard, that is, that it can still be filed. In doubtful cases it is commendable to anneal the regulator. The color produced thereby is easily polished away; it can be left, however, without detracting from the appearance of the part.

215. It is also necessary to grind the regulator round underneath and to take off the sharp corners, since the gilding of the bridge suffers by its being moved to and fro.

If the cap jewel plate in the regulator is entirely too large so that it cannot be rendered suitable by turning down or grinding because the screw holes would come too near to the edge, one of the two parts are to be replaced.

216. A very disagreeable but frequently occurring error consists in that the two small countersunk screws do not draw, whereby the plate loses its firmness and the entire regulator arrangement its secure motion.

The reason why these screws will not draw is frequently because the thread in the hard plate is good for nothing, and the remedy to be applied is to soften the cap jewel plate, to cut in a new thread, hardening it again, and then to polish or nicely grind it.

217. The plate may also be annealed in the following manner by which the polish is preserved: It is suspended to a thin wire which is dipped in oil and set on fire, but the complete burning is prevented by immersing in water. This process, repeated a few times, will result in preserving the polish uninjured while the steel has become essentially softer, so that the cutting in of the thread may next be successfully performed. Suitable screws are then made and hardened.

218. It is well to always remember toward which side the plate was fastened when the balance spring was laid, as it frequently occurs that it is by the thread divided into two unequal parts. This may sometimes be turned to account by screwing, in the case of too large a spring, the larger part of the plate to the front, and with a small spring the smaller part, because the circle then becomes smaller.

219. The cap jewels must be *well* polished and be without scratches; they must also lie firm; otherwise irregularities in the adjusting are easily provoked. The lower cap jewel, in case it is to be replaced, is best provided again with a setting while the upper

one can be cemented in. For this purpose the cap jewel plate is placed upon a screw annealer together with a suitable cap jewel, a little cement is laid above in the hollow and permitted to run well around the cap jewel by holding it above an alcohol flame.

## CHAPTER XVII.

### ADDITIONAL REMARKS ABOUT SCREWS AND BRIDGES.

220. In the adjustment the greatest attention must be paid to every part; this is also applicable to the screws. The work will bear testimony how it has been treated, and advertise the botch if it contains screws that are either bad or do not draw or have their heads disfigured.

221. At the time of placing in the screwdriver attention must be paid to the slit whether it be not too small or too shallow, whereby a jumping of the screwdriver might be provoked. It frequently happens with ordinary watches that the slits have been cast in to one side. All such defects are corrected at once by placing such screws into a screw head polishing tool and improving the slits. There is no danger in the subsequent screwing in and unscrewing or injuring the so-called "tallow top" by the jumping of the screwdriver, or the screw countersinks upon the bridge.

222. By a repeated screwing in and unscrewing, especially with finer threads, the screw must be cleaned with a stiff brush and a little oil is to be applied. It is also advisable to round off all the lower end as they screw in better and do not as easily ruin the thread in the plate.

223. Should it happen that a screw breaks during work, because it was too hard or burnt, try to turn out the end still sticking in the plate with the point of a graver. If unsuccessful, use the turning lathe as universal remedy, by fastening in it two old centers arranged for the purpose which seize the stump well. Now place the plate between these centers, press the movable part of the lathe, the tail-stock, with a strong pressure against the broken end of the screw and turn the plate. You will, in the majority of instances, succeed in turning out the screw stump without injuring the thread or requiring a separate instrument for the purpose.

224. Such a screw may be replaced by one bought at a material dealer. It is advisable to harden a right long screw of each kind of thread, to grind it square and to use it as a tap should the thread not agree with those of the ordinary tap plate.

If the screw draws well shorten it and make the head to suit, also provide the screw above and below with slits. The lower slit is cut in for the purpose to more easily get the screw out in case it should break at some time. The screw is then hardened in oil, cleaned and annealed brown. It is then ground again, richly polished, and it then receives the color to match with the other parts of the movement.

The best instrument for polishing the screw is a bell metal polisher and diamantine. If the screw is to be flat altogether, grind and polish it with a flat polisher.

225. With scratched-up screws it is not always necessary to polish or to grind them anew, but the tempering color is taken off with an old buffstick and red stuff or wood and diamantine, after which the screws are again annealed.

226. Regarding the bridges it must also be mentioned that they must be in such an order as to be with ease lifted from the plate; that a slit or notch must be there for lifting them off which has to be located at a proper place; if not, it has to be filed in. If a few bridges sit too firmly pass a broach through the foot-pin holes in the plate. In no instance must bridges be so loose that they shake and have first to be placed firm when a wheel is mounted, and this has to be corrected by drilling in one or two foot pins.

227. The process is as follows: With the point of a pegwood draw a line around the mounted bridge for the purpose of finding the most appropriate place for the pin to be drilled in. At the most suitable spot mark the place upon the plate and drill a sufficiently large hole. Then mount the bridge exactly true, and continue the



same hole into the latter but take care not to drill it through. Then file a tapering, truly round pin and beat it firm in the bridge, make it of a corresponding length and round it off. The new hole in the plate is next to be broached until the bridge can be mounted upon the plate with a slight pressure.

If a bridge does not sit firm and flat upon the plate and cannot be corrected by filing, drill one or two pins below in the bridge and make them of such a length that the bridge stands secure.

(To be Continued.)

### Problems in the Detached Lever Escapement.

BY DETENT.

IN REPAIRING escapements the familiar motto of Davy Crockett—"be sure you are right then go ahead"—is a golden one, and there is no way we are going to establish a faith like the study of our model. Almost every condition conceivable of a lever escapement can be got by changing the adjustable parts of our model, and certainly if we know how to alter and manipulate our model to get it to the same condition as our faulty watch we surely ought to be able to put the faulty parts as they should be. A common method of correcting a shallow depth is by drawing out the pallet stones. Almost universally the ratchet tooth lever has what is called close pallets; that is, the pallet stone is set in a recess sawn into the pallet arm. The stone is cemented into this recess with shellac, or shellac and a small addition of gum myrrh. The way to proceed to draw out a pallet stone is first to get the fork and roller action as it should be, but not bank up to the drop as directed when the pallet action is made right, but let the banking pins be set so the roller and fork action is all right. Next remove the balance and try the lock and drop as directed in former article. In this way you will quickly see which pallet is in fault; sometimes both will be too shallow, but usually correcting one pallet will make both all right. In order to soften the cement (shellac) which holds the pallet in place, we should clasp the pallets with a pair of slide tongs hot enough to blue and spoil them. The position of the tongs and pallets are shown in fig. 1, where *B B* represents the jaws of the

forward, it should be tried by placing it in a depthing tool with the scape wheel. (It is to be understood that the exact depth is taken in the depthing tool from the plates of the watch). When the scape wheel and pallets are in the depthing tool lock and drop should both be looked to, as frequently when the pallet stone is drawn forward there will be hardly or any *draw* to the pallet. *Draw*, as the reader will remember, is the tendency of the locking face to hold the lever against the banking pins. This will be better understood by inspecting fig. 2, where *A* represents the pallet arm and *b* the tooth acting against it. It will be seen that the tooth hardly locks on the pallet stone in its original position which corresponds to the dotted line *c*. Now, when the pallet stone is pulled forward until it corresponds to the dotted line *f*, it may be found that there is not sufficient draw to hold the lever securely against the banking pins. Turning the stone as shown at the dotted lines will remedy this, but it will be found that the angle at *d* is advanced too far to allow the tooth *b* to drop. Now the state of affairs is, there is no more lock or draw on the pallet stone at *g* than is desirable; and we must remove the surplus stone at the angle *d*. Or in other words, we must grind off the angle at *d* and re-polish it. There are a great many devices for doing this thing, and a skillful man will grind and polish a pallet stone with almost no guide but his eye; but it is not to be supposed all watchmakers are pallet makers. I shall, therefore, give a simple and inexpensive tool for holding the pallets, and describe the necessary laps. Three laps are the best, *i. e.*, a diamond lap, an emery lap, and a rotten stone lap. The laps are shaped as shown in fig. 3, and are made of a disc of copper about 1 inch in diameter, attached to a short chuck *E* made of brass or steel with a screw *h* which screws into any going arbor lathe. The copper lap *D* is turned and ground flat on the face, and if a diamond lap is used it must be charged by rubbing into the face diamond dust with a burnish. The other two laps are used with fine emery and water or rotten stone and water as will be directed. One thing must be strictly observed, and this is the distance from the shoulder of *h* to the face of *D* (that is, from the dotted line *i* to *j*), must be equal in all the laps, or it will interfere with the angle in grinding and polishing. The instrument for holding the pallets is very simple and easily made, and consists of a T-shaped piece of brass shown at *F L*, fig. 5. This piece is provided with two screws shown at *k l* which will enable us to grind and polish a pallet stone to any angle. We will first describe the part shown at *m*, fig. 5. It should be made of steel and hardened, and is shown enlarged at fig. 7, as seen in the direction of the arrow above *m*, fig. 5. A vertical section of this view on the dotted line *t* is shown at *N*. This steel piece is attached to *L* by a square tennon shown at *u* going through *L*, and held in place by a nut on *r*. On the opposite end of *s* is another T-shaped bar as shown at *m*; this bar is round on one side and pierced through from *o* to *p*. The end of *m* is shown at *o* in diagram *N*. It will be seen that the end of *m* as shown at *N* is round, and has a hole into which the taper screw *o* goes. The plan of holding a pair of pallets is to remove the staff and lever and pass the taper headed screw *o* through the hole where the pallet staff goes, and put the screw *o* through the hole in *m* and screw on the round nut *p*; this, of course, will draw the screw *o* in until the taper head will go no deeper. The outer end of the round nut *p* is slotted as shown at *v*, which is an end view. At *N*, fig. 6, will be seen at *o* the shape and position of the part of *m* against which the pallets rest. At *P*, fig. 6, the dotted lines show the fixed steel holding part *m s* attached to *L*, and the full lines represent the screw *o* and nut *p*. At fig. 4 the device is shown as applied to the lathe, *H* representing the bed of the lathe, *G* the part which carries the tool post. The two screws, *k l*, go at their points into pits drilled into *G*. It will be seen that by moving *G* to an approximate position and shifting the pallets *n* on *o*, that by means of the screws *k l* an angle can be ground and polished to any degree of accuracy. We will suppose it is the surplus angle at *d*, fig. 2, we wish to remove (grind off and polish). We first put in our diamond lap (or the emery lap will do without

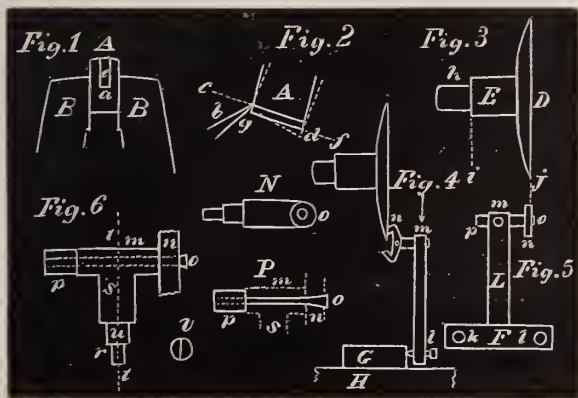

tongs, *A* the pallet arm, *e* the pallet stone. Now, by means of a pointed instrument applied at the base *a* of the notch in which the stone is set, it can, when the cement is softened by heat, be pushed forward. It is not well to advance the stone any more than is absolutely necessary, because pushing the pallet stone about in the slot will remove more or less of the cement and have a tendency to weaken the stability of the stone. It is well after the correct position is established to re-cement the stone in position, or subsequent brushing may loosen it entirely. For this purpose shellac dissolved in alcohol until of the consistence of honey is the best; it should be applied to every groove between the pallet stone and the pallet arm, and then heated up enough to drive off the alcohol; the surplus shellac can be scraped off and the surfaces cleaned by a flattened end of pegwood dipped in alcohol. After moving a pallet stone

a diamond), and grind off the face of the stone to the correct angle. Then remove the grinding lap and substitute the polishing one charged with rotten stone and water. We will continue the details in our next.

### The Goldsmith.

[By JOHANNES PRETZLAFF, Dresden.]

*Continued from Page 112.*

*White-pickling silver.*—The purpose of the pickling of silver is the same as that of the coloring of gold; by the dissolving acids the accompanying alloy is dissolved from the surface, whereby this is made purer and appears of the color of the pure and unalloyed metal.

After the article has been ground well it is heated to red heat, and, when cold, boiled in water which has been charged with a sufficient quantity of sulphuric acid, so that it has the acid taste of sharp vinegar, in which fluid it is boiled for 1 or 2 minutes. The crust formed upon the surface of articles which are to be burnished is rubbed off with fine sand or with the scratch brush and beer; articles which are to be matted with the mat-brushing machine are brushed off with chalk and alcohol. This process of glow-heating, pickling and brushing is to be repeated three times.

There is another kind of pickling, by boiling the glow-heated articles in water which contains in solution 1 part cream of tartar and 2 parts table salt.

Silver articles which are to preserve the hardness imparted to them by rolling or hammering, which consequently cannot be glow-heated, pickled by being uniformly coated with nitric acid or by being silver plated.

*Mat-pickling silver.*—Articles which are to be pickled white and mat are coated and glow-heated the last two times with a finely-pulverized mixture, prepared with water, 6 parts well calcined cream of tartar, 4 parts pure potash and 3 parts good charcoal; the articles are tempered in water, and after this coating has been softened and taken off they are boiled in alum water or in the ordinary silver pickle.

*Mat-brushing the pickled silver.*—The sand-blast apparatus was formerly used for this purpose. The process at present is the same as that used for colored gold, only the brush is different; the threads for the silver brush have a length of 5 centimeters (about 2 inches), and its outer extremities only strike with the greatest force; beside this, the wires are a little thicker and consist of very fine steel wire.

#### GILDING.

*Fire gilding.*—To one ducat or  $3\frac{1}{2}$  grams ( $2\frac{1}{4}$  dwts.), which has been rolled into the thinnest possible sheet and cut into small pellets, take 30 grams ( $19\frac{1}{3}$  dwts.) of quicksilver. After having coated a crucible well with wet chalk inside and slowly glow-heated it in the fire, put the gold and quicksilver into it, shake it quickly for about one minute, and pour the amalgamated salt into a dish filled with water. The article to be gilt is well cleaned and then "quickened." The "quickening fluid" is prepared from quicksilver which was dissolved in pure nitric acid and largely diluted with water.

When the article has everywhere been coated uniformly with the quicksilver, and is white all over, the amalgamated or ground gold is applied with the copper spatula, and while the quicksilver is evaporated by heating the article above a charcoal fire, the amalgam is gently and equally spread out with a hare's foot. This process is repeated three or more times, in accordance with whether the article is to be gilt strongly. Chains and other objects of a like nature can, after they have been quickened, be shaken in a bottle with the amalgam and evaporated upon a piece of sheet iron above the fire, a procedure also repeated several times. The article is then scratch-brushed with beer and treated with gilders' wax.

For green gilding take 1 part fine gold and 1 part fine silver for the amalgam.

#### GILDERS' WAX.

10 parts white wax, 3 parts verdigris, 2 parts sulphate of copper and  $\frac{1}{2}$  part borax; or, 10 parts wax, 3 parts verdigris, 3 parts white vitriol (sulphate of zinc), 4 parts red bolus, 2 parts pure copper ash, 1 part sulphate of iron and  $\frac{1}{2}$  part borax.

These parts are powdered finely and well mixed. So as not to breathe in the verdigris it is well to bind up mouth and nose and breathe through the cloth. The wax is liquefied in a clean vessel above a flame, and the powders are stirred in. When they have been well incorporated by constant stirring the gilders' wax is poured out upon a cold plate, that it may be lifted off well and that the heavy portions will not settle to the bottom.

When the fire-gilt article has been treated with the scratch brush and beer it is heated above an alcohol flame and rubbed with the gilders' wax; the article is then made pretty hot, so that the wax burns off, and cooled in clean or cream of tartar water. Before it is burnished with the burnisher it is brushed with dark beer and a scratch brush.

If the color is desired very lively and reddish glow-heat the article twice with the second recipe and cool it off only the last time.

Another process without gilders' wax is as follows: The article is coated with 2 parts copper ash, 1 part red cream of tartar and 1 part salt, which is pulverized and stirred into a paste with vinegar; it is made pretty hot with it, so that the color boils up and almost dries, after which it is cooled in warm cream of tartar water.

For filigree and mat articles take  $1\frac{1}{2}$  parts sal ammoniac, 1 part verdigris,  $\frac{3}{4}$  part white vitriol and  $\frac{1}{4}$  part saltpeter.

#### COPPER ASH.

Commercial copper ash is frequently not clean, and it is advisable to prepare it at home. When a copper sheet, dipped in salt water, is glow-heated and cooled in clean water a black scale will peel off. This process is repeated as many times as necessary to prepare copper ash. The water is poured off and the sediment dried.

#### GALVANIC GILDING.

To one ducat of  $3\frac{1}{2}$  grams fine gold take 15 grams (9 dwts.  $15\frac{1}{2}$  grains) crystallized carbonate of soda, 75 grams (2 ozs. 8 dwts. 5 gr.) prussiate of potash, 1 wine bottle full of distilled water.

After the ducat has been rolled into a very thin sheet, glow-heated and cut into small pieces, in a flat porcelain evaporating dish pour a small quantity of chemically-pure nitro-muriatic acid upon it (this acid is a mixture of two parts muriatic and one part nitric acids). Place the dish over a small flame, dissolve the gold and permit the solution to evaporate to a thick dark-brown mass, with edges tinged reddish. It is necessary to do this with much care; if it is not evaporated sufficiently thick too much acid will remain in the solution, and if too thick the gold will re-crystallize. In the last moments agitate the dish briskly and draw the crystals forming around the edges back into the solution. When the right moment has arrived pour one-half tumbler full of warm distilled water into it.

The cyanide of potassium, soda and prussiate of potash dissolve meanwhile in a pot, glazed within, in the warm distilled water, one-half a tumbler of which has been left for the gold solution, and then pour the gold solution into it. The gilding will at first color dark brown; when it has stood for some time it will clarify completely, and it is advisable not to take it into use at once.

A red gilding is produced by adding a little copper to the gold solution and dissolving it with it; a green color by adding a little dissolved silver to the gold solution; or else cyanide of copper or cyanide of silver to the gold solution. A 14-karat color when both copper and silver are added.

#### FILTERING.

Should the gilding remain turbid against all expectations, or have become impure by reason of prolonged use, the fluid must be filtered.

Double the filtering paper and lay it into a glass or porcelain funnel and place it into the neck of a well-cleaned wine bottle. So as

not to exclude the air place a piece of wood or wire between the bottle and funnel, and let the gilding ooze through the filtering paper. The sediment can be mixed with the stonings, as particles of gold may be contained therein.

*Galvanic element for gilding.*—This is made in the simplest and most practical manner by taking a large pot, glazed within, fill it with water strongly saturated with table salt and place a clay cylinder filled with the gilding in the center of the pot. The gilding must stand at equal height with the salt water, as the clay cylinder is porous; if the salt water was to stand higher it would, with time, ooze through the pores into the gilding, or vice versa. Then bend a cylinder from strong zinc plate, and, with tin solder, solder a sufficiently thick brass wire, a little flattened by rolling and glow-heated, vertically upon it. After the zinc cylinder has been placed into the salt water, wherefore between pot and clay cylinder, bend the brass wire so that its end stands horizontally over the clay cylinder, from which the articles to be gilt are suspended into the gilding by means of a fine copper or brass wire.

So that the galvanic current is not interrupted it is necessary to keep the brass wire clean by means of emery paper; it is also necessary to beat off the salt from time to time. The striking out of the salt can be prevented by anointing the edge of the pot with tallow. During the gilding it is well to place the element in a warm place.

#### CONTACT GILDING.

The fine gold is dissolved in the same manner as is described under the head of "galvanic gilding," and to 1 part gold take 6 parts prussiate of potash, 6 parts purified table salt and 4 parts carbonate of potash which has been dissolved in about 50 parts distilled water. After the gilding, which has previously been diluted somewhat, has been poured in, the whole mixture is boiled up and filtered in the manner specified farther above.

The galvanic element is not used for this gilding, as a very feeble current already exerts an influence, and any pot, porcelain or glass vessel may be used in gilding by hanging or standing the article to be gilt, together with a clean strip of zinc, into it in such a manner that both come into contact. If the object to be gilt, such as a cup or a snuff box, is to be gilt on the inside only, it is filled to the edge with the gilding fluid and a strip of zinc placed in. When to be used the gilding is to be warmed.

#### GILDING BY RUBBING.

Dissolve 1 part of thinly rolled and glow-heated fine gold in about 8 parts chemically pure nitro-muriatic acid; let the solution be absorbed by clean linen rags, which, when dried in the air or sun, are in an alcohol flame burned to ash. The gilding is with this brown powder rubbed on with a cork dipped in salt water.

If the gilding is to be reddish dissolve a ducat in 30 grams nitric acid,  $3\frac{1}{2}$  grams Arabic sal ammoniac and 1 gram saltpeter; then add a little rolled copper, clean steel filings or verdigris to the solution, dilute it with water and proceed as previously specified; or by the first process also dissolve a little copper with it.

#### SILVER-PLATING.

*Fire silver-plating.*—To 1 part rolled fine silver take 4 parts pure quicksilver, and observe the same process as specified for fire gilding. Before pouring out the amalgam stir it well in the crucible with a wooden rod to satisfy yourself that silver and quicksilver have intimately combined.

Another process consists in kneading with water to a paste 1 part dry dissolved silver, 4 parts rock salt, 4 parts white sandiver, 4 parts sal ammoniac and  $\frac{1}{4}$  part quicksilver. The article to be silvered is coated uniformly with this salve, brought to running upon a charcoal fire, and cleansed by pickling.

*Galvanic silvering.*—Dissolve 15 grams (9 dwts.  $15\frac{1}{2}$  gr.) fine silver in chemically pure nitric acid, dilute this solution with distilled water, and precipitate the silver with table salt from the solution. This precipitate, washed with warm water, is in a still moist condition introduced into a solution of 192 grams (6 ozs. 3 dwts. 11 gr.)

in 5 to  $5\frac{1}{2}$  pounds water, add also 128 grams (4 ozs. 2 dwts. 7.3 gr.) spirits of hartshorn, boil it for one hour, replacing the evaporated water with other hot water and filter the silvering.

Or, pour this precipitate into a solution of 100 grams (3 ozs. 4 dwts.  $7\frac{1}{2}$  grains) of yellow prussiate of potash and 100 grams bicarbonate of soda in 1 liter (1 quart) distilled water and 100 grams spirits of hartshorn, boil this silvering for a while and filter it.

Or, to 50 parts distilled water and 5 parts spirits of hartshorn add 1 part chloride of silver, 5 parts calcined soda or potash and 2 parts table salt; boil this mixture, replacing the evaporated water, for one hour, filter it off from the separated oxide of iron, and store the pale yellow silvering after use in a well-corked bottle.

Or, dissolve 18 grams (11 dwts. 14 gr.) nitrate of silver in one pint or one quart of distilled water, and drop in a solution of from 30 to 35 grams (1 oz. to 2 ozs.  $2\frac{1}{2}$  dwts.) of cyanide of potassium until the at first produced precipitate (cyanide of silver) has completely dissolved. The solution, after it has been filtered, may at once be used.

Or, 175 grams (5 ozs. 12 dwts. 12.56 gr.) are dissolved in  $4\frac{1}{2}$  quarts distilled water; to it are added  $52\frac{1}{2}$  grams (1 oz. 13 dwts. 10.46 gr.) freshly dissolved silver, precipitated with salt and washed, 135 grams (4 ozs. 6 dwts. 19.3 gr.) crystallized carbonate of soda and 70 grams (2 ozs. 5 dwts. 0.2 gr.) table salt. This silvering is especially suited for steel and iron.

The solutions with cyanide of potassium are to be stored in dark colored glass receptacles in a dark place.

The single apparatus cannot well be used for the galvanic silvering, as a stronger current has to be brought to bear, wherefore a battery must be employed.

(To be Continued.)

#### The Gorham Manufacturing Co.'s New Building.

AMONG THE elegant business structures recently erected in New York, few are more striking in appearance or attract more general commendation than the one built by the Gorham Manufacturing Company, at the corner of Broadway and Nineteenth street. The style of architecture is closely allied to the Queen Anne—in fact, it may be called Queen Anne with modern modifications, and from its peculiar architecture and the prominent position it occupies, is one of the most conspicuous buildings on Broadway. The main front is, of course, on Broadway, but the most conspicuous part is the Nineteenth street side where the full depth of the building is exposed. It is built of brick with elegant terra cotta trimmings and ornamentation, with numerous turrets and gables rising from the roof, diversifying and adding beauty to its general appearance. It is nine stories high with basement and sub-cellar. The Gorham Company occupy the first and second floors and all the space below the surface of the street. The retail department is located on the first floor, opening directly upon New York's greatest and most fashionable thoroughfare. On stepping inside one is impressed with the spaciousness of the store, with its high ceiling, large windows and abundance of light. The ceiling is elegantly decorated, while all the wood work is of highly polished cherry. The large array of show cases—each in itself a good sized glass enclosed exhibition room—are of mahogany and heavy plate glass, having balanced sashes that give easy access to their interiors. In this room and these cases is exhibited the abundant stock of elegant silverware that the Gorham Company keep constantly on hand for their trade. Here can be found everything desired in the silver line, the stock embracing all the latest designs in rich goods, some of severely plain patterns and others elaborate in their ornamentation. At the rear of the store an elevator and a broad and inviting staircase leads to the wholesale rooms on the floor above. These are also finished in mahogany, and the immense show cases are of the same material and heavy plate glass. The private offices of the members of the firm are at the rear of the stores and are both

elegant and convenient. In the basement the packing and shipping departments are located, and every convenience is provided for the rapid filling of orders. The planning of the building and the supervision of its construction have mainly fallen to Mr. Edw. H. Kendall, architect of the Field Building, No. 1 Broadway, and many other fine structures, who has shown excellent taste and rare good judgment in providing the best facilities for displaying the products of the Gorham Manufacturing Company and for transacting its immense business. The elegant and artistic show cases were made by B. & W. B. Smith, of this city, the well known manufacturers of this class of work. The elegance of the building and the magnificence of the goods displayed form one of the most attractive sights along Broadway. One of the features of this establishment is the introduction of the Edison system of electric lighting, the plant having a capacity of 288 lamps, and this has already been tested and found to work admirably.

### Lathes and Lathe Work.

BY THE MODEL WATCHMAKER.

THERE ARE few persons but think they know what a lathe is, and most of these persons think a lathe will turn anything perfectly round. Now this is a great mistake, such a thing as a lathe which will turn *perfectly* round has never been made, and it can be asserted with tolerable certainty that it never will be. Still it is well known a certain degree of accuracy is attainable, and the standard of accuracy is every year getting higher in lathes of all descriptions, from the hardened and ground spindle of the lathes intended for watchmakers' use up to the ponderous lathe weighing many tons for producing marine engines. As an illustration of the improvements made in the last mentioned lathes: Watt, the father as he has been termed of the steam engine, early in his efforts to find proper machinery and artisans to carry out his ideas, wrote a friend that he was now very sanguine of success, as he had found a man who could bore (turn) out the inside of a cylinder for his engines to such a degree of accuracy that they would in no way vary from the perfect form to exceed the thickness of an English sixpence (about like our ten-cent pieces). And the cylinders he was experimenting with did not exceed 2 feet in diameter. At the present time such cylinders could be bored out with no variation to exceed  $\frac{1}{10000}$  of an inch. In the present communication the writer proposes to commence a short series of articles on a tool making lathe of a desirable degree of accuracy, which can be built at a comparative low cost except the maker's own labor, and this outlay of labor is abridged in every way consistent with good work. The lathe will turn and grind spindles or arbors up to 18 inches in length, also cut screws of the same length. The reader is warned the lathe is intended for service, not for beauty; but for the quality of work nothing in use is going to beat it. The lathe will in many ways vary from any in general use, the most conspicuous variation consisting of the use of *two* dead centers. This departure from the *rut* of lathes in general use is only going back to the model of the old bow lathe. Another departure consists in using a milling tool in the tool post instead of a direct cutting tool. The writer does not claim this as an invention or introduction of his own, as it was used in the Royal English Mint twenty-five years ago. The advantages of these changes will be pointed out as the articles progress. It is not to be understood that a mill or rotating cutter is to be used in the tool post to the exclusion of a direct cutting instrument, but only when extreme accuracy is desired. The only parts really necessary to have made outside of the place for coarser work, such as every watchmaker should have, will be the bed or ways and a feed screw. The bed should be of cast iron, quite heavy and proportionately rigid. It must be understood that accurate work cannot be done on a light tremulous lathe. Subsequently, if the reader desires, he can make a light elegant lathe for general use, but the one under consideration is for strength and accuracy. The ways or bed is 24 inches long and  $6\frac{1}{2}$  wide by 4 deep. At fig. 1 is a plan of the

lathe bed looking downward. Fig. 2 is an end view seen in the direction of the arrow *a*, fig. 1. At fig. 3 is shown a transverse section on the dotted line *b*, fig. 1. The three ways shown and designated at *A B C* are planed as near accurate as possible and finally ground with an emery wheel in a parallel grinder. The outside edges of the ways shown at *c d e*, fig. 2, are also ground true and parallel, but on a slight bevel. There are many places in the country where such a set of ways could be planed up and also ground in a parallel grinder. All the watch factories have such machines, but will not undertake to do outside work; but Brown & Sharp, Providence, R. I., so justly celebrated for accurate workmanship, will plane and grind such a set of ways. If the reader should send to them it would be best to send the wood patterns in a strong box, let them get them cast and use the box to ship the finished ways in return. The writer has a lathe of this kind, but it was made at one of our principal watch factories, and with which he was connected for some years, consequently he cannot give an estimate of the probable cost of such a set of ways, but he has written to several houses competent to do such work and will give the most favorable figures in the next communication.

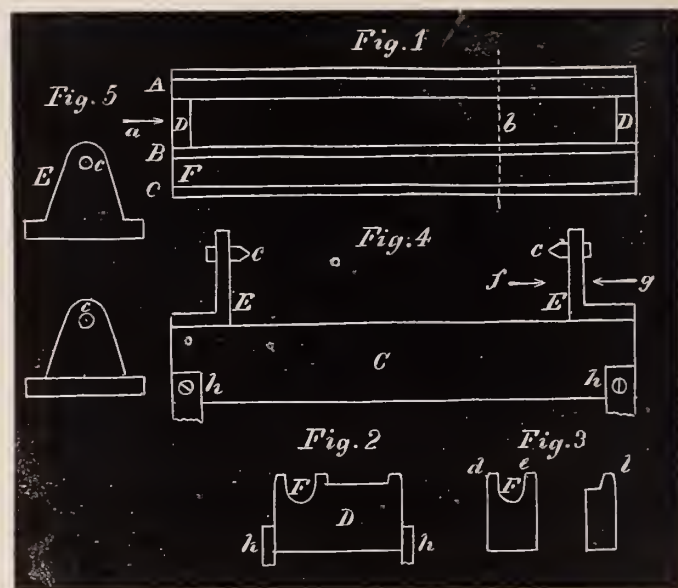

The screw is to be more readily obtained of sufficient accuracy even for microscopic measuring tools. It may be well to say here that the production of extremely accurate screws has been attracting considerable attention and subsequently the subject will be taken up. The screw to be used with this lathe is 20 inches long, turned from a round bar of annealed steel 1 inch in diameter, and reduced in the lathe by turning to about  $\frac{7}{8}$  with 10 threads to the inch. This number of threads will be very convenient for producing screws to the decimal parts of an inch. The writer uses inches and decimal parts of an inch for the reason that he believes it will be a very long time before the French standard will be generally introduced. But this has no bearing on our lathe, and for that matter it makes but little difference what system or rather what standard we use only so we measure correctly. At fig. 4 is shown a side elevation of our lathe. Both pieces marked *E* can be considered as tail stocks, but either can be used to propel the work in the lathe. The cuts and description in this article is only intended to give general ideas of principles, but as the articles progress full details of size and mode of action will be given. The idea is, we can put (say to illustrate) a round steel bar in our lathe between the centers *c c*, fig. 4, and apply our dog at either end and turn with our slide rest (to be described) up to the dog; then we can apply another dog to the end we have just turned and remove the dog we started with and cut a continuous chip from end to end. This lathe can be run by either hand or foot power, the former being the best for slide rest jobs. The counter-shaft driving the lathe is placed in the rear of the lathe and not shown in these cuts. The feed screw lies in the recess *F*, figs. 1 and 3, and is driven by a system of wheels recessed into the heads *E E*. These wheels are changeable so that fine and coarse feed can be

given and screws cut of desirable number of threads to the inch. In most jobs one would want to do, but one head would be used and the result would be exactly as in any slide rest screw cutting lathe, except there would be no live center (spindle). Such a lathe will turn and cut the thread on a screw  $\frac{1}{16}$  of an inch in diameter or turn a set of jewelers' rolls. I don't wish to be understood to say this lathe will do the work so quickly as a heavy engine lathe driven by steam, but I guarantee it shall do it as well and grind them off after hardening. In this case the grinding can best be done by foot power, but the turning and shaping by turning a crank by hand. Fig. 5 is a view of the head *E* seen in the direction of the arrows *g f*. The cuts are  $\frac{1}{16}$  size.

[Copyright Secured.]

### Letters to Watchmakers.

[By DR. LEONARD WALDO, Astronomer in charge of the Horological Bureau of the Yale College Observatory.]

V.

HOW TO OBTAIN THE TIME.—(Continued.)

TO ILLUSTRATE by an example, suppose that we have found from a city map that the point where exact longitude we want is about four thousand feet west of the State House steeple in Philadelphia, and that it is north of the State House about twenty minutes of latitude. We find from the map that the latitude of the State House is about  $39^{\circ} 57'$ , and  $20'$  added to this would give us  $40^{\circ} 17'$  for the latitude of the place of our supposed transit instrument, and of which we want the longitude from Washington. Now, the length of one degree of longitude for  $40^{\circ}$  of latitude is 53.056 miles, and for  $41^{\circ}$  is 52.274 miles. We want the value of a degree of longitude for  $40^{\circ} 17'$  and the simple proportion

$$(53.056 - 52.274) : x :: 60 : 17$$

$$\text{whence } x = \frac{17}{60} (53.056 - 52.274) = 0.2215$$

gives us the fraction of a mile (*x*) which corresponds to the seven-tenths minutes of latitude above  $40^{\circ}$  at the point we have chosen. We have, therefore, the length of one degree of longitude in the latitude of  $40^{\circ} 11'$  to be

$$53.056 - 0.222 = 52.834 \text{ miles,}$$

which means that if in the latitude  $40^{\circ} 17'$  we travel due west for 52.834 miles, we shall find the local time one degree or fifteen minutes of time slower than at the starting point. The point we have chosen is but 4,000 feet west of the supposed starting point. Our time, therefore, will be slower than the starting point time by the fractional part of a mile which is represented by

$$\frac{4000}{5280} = 0.758$$

and this distance in time will be expressed by the proportion

$$52.834 : 0.758 :: 15 \text{ minutes} : x$$

where *x* is the time required expressed in minutes. We find, therefore,

$$x = \frac{15 \times 0.758}{52.834} = 0.2153 \text{ minutes} = 12.92 \text{ seconds.}$$

The longitude of the State House, taken from the table, is  $7^{\text{M}} 35^{\text{S}}.92$  east of Washington, and our new point we have just found to be  $12^{\text{S}}.02$  west of the State House. We find, therefore, that the longitude of our assumed point is  $7^{\text{M}} 23^{\text{S}}.0$  east of Washington, or that when it is noon at Washington it is  $12^{\text{H}} 7^{\text{M}} 23^{\text{S}}.0$  at our assumed station in latitude  $40^{\circ} 17'$  north.

If, therefore, we receive by telegraph the true Washington (Observatory) noon signal, our clock ought to indicate  $12^{\text{H}} 7^{\text{M}} 23^{\text{S}}.0$  if we had previously set it by our own observations of local time.

If the telegraphed time signals are for the *V*th hour west from Greenwich, then we must remember that Washington is  $5^{\text{H}} 8^{\text{M}} 13^{\text{S}}.09$  west from Greenwich, and that consequently our assumed local time will be  $49^{\text{S}}.09$  slow of the *V*th hour telegraph time signals.

If the local time cannot be obtained by telegraph, then the time must be obtained by direct astronomical observations.

The sextant, or octant, or quadrant, are familiar in form to watchmakers but are very little used by them for determining the time.

This is hardly as it should be because instruments of this class are small, easily handled, not expensive and the time can be determined by them quite easily to within a second. I think the objection to their use arises from the feeling that the calculations are troublesome. This is an objection that will diminish after a trial of the method.

The observer should begin his course of sextant practice by becoming expert at pointing it at the sun, and determining the index error by the methods laid down in the astronomy books or the Practical Treatises on Navigation. After he can easily manage the two images of the sun looking directly at it, then he should practice the use of the artificial horizon. A very good artificial horizon is made by a bowl of molasses, which is a good thing to know sometimes, when no regular mercury horizon is available.

There is little use in trying to observe the stars until the observer has become thoroughly familiar with his instruments, and the comparatively easy observations of the sun in the daytime.

It is much more difficult to find the reflected image of the star observed, it requires some little knowledge of the constellations to pick out the stars to be observed, and there is always more or less embarrassment and confusion from having to work in the dark. I never had much satisfaction from this kind of observing until I used a simply made support for the sextant which firmly clasped its handle but at the same time allowed the sextant to be moved vertically. I think there is a good deal of pleasure in working out one's time from sextant observations. With two stars properly selected, one east, the other west of the meridian, the observer ought to be able to take out his sextant, get ready for his observations, make them and compute the error of his chronometer and clock in half an hour. This, of course, is longer than would be required for a reduced observation of a single star with a transit instrument.

I cannot, in the limits of this article, go into a description of the actual methods of observing with the sextant. These can easily be obtained from the books; but I ought to explain something about the books from which he will get his position of the sun and stars, and by which he will convert the star or sidereal time into mean solar time. This book is the American Ephemeris and Nautical Almanac. It is published by the Bureau of Navigation in Washington, and can be purchased from the Bureau or from dealers in navigation instruments. I think the price is \$1.50, but of this I am not sure. The volume for 1884 contains about five hundred large octavo pages, of which the first half is occupied with the sun, moon and principal planets referred to the meridian of Greenwich. At page 293 in the Ephemeris for 1884, begins the list of the principal fixed stars for the year 1884, and pages 302 to 364 inclusive are occupied with their places as seen by the observer every ten days throughout the year. For instance, take the star Alpha Lyrae or Vega at page 351. We find, for instance, that on May 9.6, that the Right Ascension of this star is 18 hours, 32 minutes, 62.86 seconds, and that it was increasing this Right Ascension at the rate of 0.27 seconds in ten days at that date. This is indicated by the 27 printed in small type adjoining the number 62.86. The Right Ascension of a star is the sidereal time at which it crosses the meridian, and if we could determine by any means exactly when Vega crossed the meridian on May 9th, we could find the error of our observing timepiece by knowing this true sidereal time of transit.

May 9.6 is called the mean solar date and is the astronomer's way of indicating that the star's transit takes place .6 of a day after the noon of May 9th; the astronomer's day always begins at noon. Six-tenths of a day is about fifteen hours, and this number of hours after the noon of May 9 would make it about half-past two in the morning of our civil date, May 10th.

Suppose that we wished to convert this sidereal time of transit into mean solar time, and that we are at the station whose longitude is 7 minutes, 23.0 seconds, east of Washington.

It is quite clear that if we know the exact sidereal time on the noon of May 9th, that we can tell how many sidereal hours, minutes and

seconds will elapse until the sidereal time, 18 hours, 32 minutes, 62.86 seconds comes around on the clock face. At page 367 the last column is marked sidereal time of mean noon, and opposite May 9th we find this time to be 3 hours, 11 minutes, 39.45 seconds, which means that on the meridian of Washington at exactly 12 o'clock noon of May 9th, that this is the sidereal time.

As we go east or west from Washington, however, the sidereal time would change, becoming less as we go east. The amount of this lessening is shown in Table III. at the end of the book, where we find that for seven minutes the change is 1.15 seconds, and for 23 seconds that the change is 0.06 seconds. Or for 7 minutes and 23 seconds east of Washington we must subtract 1.21 seconds. This gives us as the sidereal time at mean noon of May 9th, at a point whose longitude is 7 minutes, 23.0 seconds east of Washington, 3 hours, 11 minutes, 38.24 seconds, and if we subtract this from 18 hours, 32 minutes, 62.86 seconds, we find that 15 hours, 21 minutes, 24.62 seconds of sidereal time will elapse from the noon of May 9th until Vega crosses the meridian.

Now, turning to Table II. at the close of the book, we find that the sidereal time interval corresponding to 15 hours, 21 minutes, 24.62 seconds must be diminished by 2 minutes, 30.95 seconds, to get the equivalent mean time interval which we find to be 15 hours, 18 minutes, 53.67 seconds. Now, remembering that 12 o'clock is taken as the no hours by all such books as we have before us, this would indicate that the true local mean time of transit of Vega over the meridian, 7 minutes, and 23 seconds east of Washington took place at 18 minutes, 53.67 seconds past 3 o'clock on the morning of May 10th.

The full relation between mean and sidereal time is explained at page 473, and the process of converting a mean solar time into a sidereal time is the reverse of that just given, except that the mean solar interval since noon is converted into a sidereal interval since noon by the use of Table III. Thus, suppose on May 9th, at half past seven in the evening, in the same longitude as before, we wanted to know the exact sidereal time, or, in other words, what the Right Ascension of stars would be which were passing the meridian at that particular instant. We know at noon of that day that the sidereal time was 3 hours, 11 minutes, 38.24 seconds, and we find from Table III. that 7 hours and 30 minutes of a mean time interval must be increased by 1 minute, 13.92 seconds to give an equivalent sidereal time interval, and adding these three quantities together we find the sidereal time at precisely half-past seven to be 10 hours, 42 minutes, 52.16 seconds.

There is always a considerable confusion in the minds of learners as to the meanings of sidereal, local, mean solar, astronomical and civil time, and the ready conversion of one into the other. As this is about the first thing which must be perfectly clear in the minds of observers, let me give a brief statement of their relations to each other additional to that found in the almanac.

*First.*—It must be remembered that in all nautical almanacs, books on navigation or practical astronomy whenever the day is mentioned, whether it be mean solar, solar or sidereal, that it begins at *noon* and not at *midnight*. This must always be remembered in the conversion of civil time into astronomical time or *vice versa*.

*Secondly.*—It is customary to write the mean solar day and the sidereal time together. Thus the sidereal time on May 9th at 7 hours, 30 minutes would be written: May 9d., 10h., 42m., 52.16s., sidereal time. In writing mean solar times the hours run up to 24 which end at noon. Thus 23 hours is really 11 o'clock in the morning. This is quite different from the 23 hours of the new 24 hour dial plan in which the 23 hours would come at 11 o'clock at night.

Sidereal time then is star time, and gains every day in mean solar time 3m., 55.90s. in order to keep up with the stars which pass the meridian that much earlier every day.

Mean solar time is solar time corrected for the equation of time, or the irregularities of the sun's motion in the ecliptic.

Civil time means that the day begins at midnight and astronomical or nautical time means that the day begins at noon.

For the purpose of rating chronometers or clocks to sidereal time (and one of these ought to be kept so rated and set to avoid the constant changing of one time to another), the Tables II. and III of the almanac referred to are very convenient.

Thus, suppose it is desired to adjust a marine chronometer to sidereal rate by comparison with a mean time clock whose rate is small. We compare both at the beginning and end of a 6 hour interval, and we find by subtracting the first comparison from the second that

$$\left. \begin{array}{l} 6h., 0m., 0s., \\ \text{by the mean time} \\ \text{clock.} \end{array} \right\} = \left\{ \begin{array}{l} 6h., 1m., 3s., \\ \text{by the adjusted} \\ \text{marine chronometer.} \end{array} \right.$$

Now, turning to Table II., we find that an interval of 6h., 0m., 0s. mean time is equal to 6h., 0m., 59.14s. sidereal time, or in other words, that our marine chronometer has gained 3.86 seconds too much, which we try to adjust the balance for and repeat the observation.

With this explanation as to the conversion of the different times in use let us consider some of the shorter methods of observing for time with a transit instrument. This instrument affords the quickest and the most accurate method for observing time, and by a proper arrangement of meridian marks and the securing of good foundations for a well made instrument, the computations may be reduced to a very few figures whether the sun or stars are observed. I shall assume that every reader is familiar with the general form and use of a transit instrument, and if he is not he can consult such books as Chamber's "Practical Astronomy" or Loomis' "Practical Astronomy," or better still for his purpose he can buy the little book, "A Treatise on the Transit Instrument as applied to the Determination of Time, for the use of Country Gentlemen, by Latimer Clark, M. I. C. E., London, published by the author at 6 Westminster Chambers, S. W., 1882." I think the book can be had of E. & F. Spoon, New York.

Mr. Clark in this book describes some small English transits which look admirably adapted to watchmakers' uses. He gives a description of the ordinary ways of getting time with a transit, and he proposes to publish annually the Greenwich mean times of transit of the brightest stars. This saves some of the trouble for American watchmakers of converting sidereal into mean time. I notice in THE CIRCULAR that Mr. Bliss advertises a small transit for watchmakers' uses which I have not seen, but which I have no doubt from the wood cut is a serviceable instrument. High priced but thoroughly good transits are quite cheap enough if the quality of labor expended on them is considered, are made by Fauth & Co., Washington, Stackpole Brothers, New York, and Buff & Berger, Boston.

It will quite pay the intending observer to get a good sized transit. With a clear aperture of two inches for the object glass, and a correspondingly large and firm stand, there is an ease and certainty of observation which the very small transits do not possess. Many stars which would be invisible in a small instrument in the day time are visible with the larger instrument, and the slightest appearance of haze or fog does not obscure the stars at night with two inches aperture as it is sure to do with one inch. If the observer proposes to only use the sun for his time work the optical power of the transit instrument is not of so much consequence. In comparing different telescopic apertures it must be borne in mind that the light gathering power for these instruments varies about as the square of the clear aperture of the object glass, and that, therefore, an object glass two inches in diameter collects about four times as much light as an object glass of one inch clear aperture.

JAMES W. MILLER, President of the Board of Trade in Newark, and senior member of the firm of Miller Bros., manufacturing jewelers of this city, recently went before the Grand Jury and entered a complaint of larceny and receiving against the firm of Smith, Heinz & Erlich and Alfred Pettit. The accused parties are said to have been arrested and held to bail for trial except Erlich who is reported to be out of town. Mr. Miller asserts that months ago he became aware that valuable patterns and forms originating with his firm had been surreptitiously taken from the factory, and, as alleged, used by the accused. Pettit, in confessing, made such statements that Mr. Miller felt it his duty to bring the matter to the attention of the Grand Jury.

## How to Make and Engrave Silver Bangles.

BY EXPERT.

LET US take a short *resumé* of what we have been considering in this series of articles. We commenced with plain, flat finishing, next designing and transfer work, then frosting and ruling in bright lines, and carried the work through all these processes, and if the tools and appliances described are on hand we can produce a great variety of work. The writer has, perhaps, been a little too extended for the production of mere silver bangles, but the monogram on a fine gold watch case is no different from a bangle except in being more labored. Since writing the article on frosting, a friend took me to task for not mentioning the ordinary two or three-rowed *matting brush* such as is sold by all our material dealers. My excuse is, I supposed everybody knew of them and how to use them, but in apology for the criticism would beg pardon of those who use such brushes, and say to those who do not that they are simply fine brass or iron wire secured in a small wooden head to use with your lathe. The wooden head is about an inch in diameter and half an inch long in the direction of the axis of the lathe. The smaller ones are of very fine brass wire, and 3 or  $3\frac{1}{2}$  inches in diameter measuring across the brush. The larger and coarser ones are of iron wire and 4 or 5 inches across. And for very fine matting they do nice work but for coarser grained frosting the *satiny finish* sticks out, *i. e.*, the work looks different when viewed in different directions. This can be remedied to a great extent by using your coarse iron brush first until a coarse grain is established, and then taking off the "satiny" look with the fine brass wire brush. Such brushes work best with stale beer or a weak solution of yellow soap and water; but such fluids are too nasty to be tolerated about a jeweler's bench, so stick to the dry work. Some care is necessary to be taken in using such brushes and especially the iron ones, or the ends of the wires will curl up and become worthless. If an American lathe is used for the larger size, the lathe can be turned to the left and the head reversed so as to let the brush be in the position shown in fig. 1.

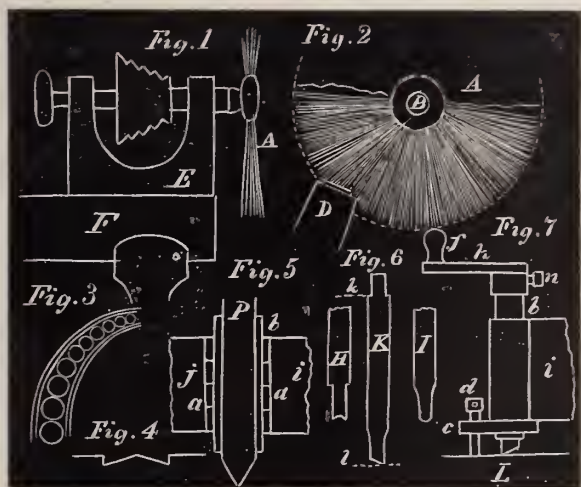

The work should be held so only just the mere tips of the wires touch the job or the ends of the wires will be curled up as mentioned above. The position of the job and about the relative closeness is shown in fig. 2, where *A* is the brush and *D* the job. In connection with the use of the pentagraph described and illustrated, is one which for laborious and expensive ornamental letters is invaluable and this is the production in bosses or beads of the same size or a gradual increase or diminution of size; as, for instance, in the portion of an ornamental *O* shown in fig. 3. To produce such a letter entirely by hand having the bosses shaped as shown in section in fig. 4 (magnified), perfectly round and even is next to impossible; but with a tool in our pentagraph they can be produced with tolerable celerity and beautifully accurate, gradually increasing or diminishing in size but with a difference only one hundredth of an inch between each, if such a degree of perfection was desired. Such an addition to our pentagraph can be quite easily made. It con-

sists of additional centers which go into the part shown at  $g^2$  of our April number. One of these centers just mentioned is simply a point for locating the position of the cutter which follows. Probably the reader will understand the arrangement the better by saying the cutting is precisely the same in principle as the old so-called end shake tool, only, in this case, the cutters are changeable and consequently capable of producing bosses from a mere point up to  $\frac{1}{8}$  of an inch in diameter, a size quite large enough for any watch case monogram one would be called upon to engrave. The reader will remember in the April number we spoke of a point holder which went into the joint at  $g^2$ . It is also to be remembered that this point holder was  $\frac{3}{16}$  of an inch in diameter. In the present instance we insert a tube, the interior diameter of which is  $\frac{1}{8}$  of an inch and the outer diameter  $\frac{3}{16}$  to fit our joint. The first mentioned locating point is simply a piece of steel wire about 2 inches long, fitting the interior of the tube just mentioned as going into the joint at  $g^2$  of the April number. At fig. 5 is shown a vertical section of the joint and tube. This figure is magnified to show the parts. The letters *ij* correspond to the same letters in the April number, while *a a* represents the joint and *b b* the tube ( $\frac{3}{16}$  of an inch in diameter), inserted into the joint; *P* shows the steel locating point. This point as well as the cutters should fit the interior of the tube *b* with tolerable accuracy, but not close enough to necessitate turning the entire length but only at the points; as, for instance, the centering or locating point; if you have an American lathe which will take a wire as large turn the point to a cone as shown in fig. 5. If you have no chuck large enough you can use a back rest. This remark applies also to all the cutters as these must be turned at their points. There should be 10 or 12 of these cutters graduated in size from one which would produce a cone  $\frac{1}{16}$  of an inch in diameter at the base, up to one producing a cone  $\frac{1}{8}$  of an inch at the base. Now, 10 cutters increasing a  $\frac{1}{16}$  at a time would produce these graduations. Even in letters  $1\frac{1}{2}$  inches high you would not need more than this number. At *K*, fig. 6, is shown a full length cutter with a shoulder turned on the top end for the reception of the crank *h*, fig. 7, which is an elevation of the device. These cutters are all supposed to be made of the same distance from the shoulders at *k* and the cutting point on the line *l*, fig. 6. To remedy any discrepancy from wear or other causes, the screw *d*, fig. 7, is used (*L* representing the job to be engraved). At *c*, fig. 7, is shown a collar soldered on the tube *b*; this collar extends forward and forms a nut in which the screw *d*, turns. The crank *h* with the crank pin *f* can be attached to the cutters with a set screw *n*. The crank pin *f* should be large and provided with a loose button as shown so it can be grasped readily and admit of a strong downward pressure. The points or cutting ends of the cutters should all be of the same level and sharpened nicely on an Arkansas stone, and finally polished so as to make a bright smooth cut. At *I H* are shown cutters of other shape which can also be used in the same way; but the kind shown at *K* is the staple. In using this device, the tracing point at *g*, fig. 1, April number, should be loaded with a weight so it will rest firm in position while the crank at *f* is worked. Of course it is understood that it is some labored monogram for which we would take so much trouble—say a gold watch case. The lid should be removed and cemented to a piece of board so we can secure it to our pentagraph bed. The letters should be outlined and the center of each cone perfectly established. We now insert the conical guide point shown at *P*, fig. 1, and move our pentagraph until the point *P* was in the exact position. We have our tracing point *g* (April number) so loaded that it will hold the pentagraph in place. We next select a cutter of the desired size and apply the crank *h* and press firmly downward, and manipulate the screw *d* (which has holes in the top) so as to let the cutter sink to the right depth in the metal. We now change the position so as to cut another boss, also changing our cutter for a larger or smaller one until our job is complete. This may seem as a very slow, tedious way to some, but to those who seek to do the very best work it will appear different;

and such a style of ornamentation would not be applied to only one letter, the others in the combination being finished in a less laborious way. Most men who buy an expensive gold watch are anxious the work on it shall be as fine as possible, and a dollar or two extra is not begrudged.

Advice to Watchmakers' Apprentices.

BY A MAN WHO HAS SPENT TWENTY YEARS AT THE BENCH.

**M**ATTING punches are made in a variety of forms, or, rather, the ends which attack the metal to be matted are cut in different manners. One of the simplest forms of punch is shown at fig. 1, where *A* represents the punch at one-half the length. They should be of  $\frac{1}{8}$  square steel tapered at the point to about  $\frac{1}{16}$ ; though, in cases of larger coarse matting, the end on which the matting tool is made can be quite  $\frac{1}{8}$  square. Sometimes the end should be three square or round to go into corners. At *a*, fig. 1, is shown the end or face of the punch of the proportionate size, and at *b* it is shown magnified. In this form the end of the punch is simply cut into lines crossing each other with a graver or screw head file. By combining and using both the graver and screw head file one will get the best results. That is by starting the cuts with the graver and deepening with the screw head file. For a punch  $\frac{1}{8}$  of an inch on the face above 5 lines will be found to be about coarse enough. Irregular forms cut on a steel bed and hardened furnishes a good original for matting punches. These forms can be made with a graver or punches in a block or die bed of soft steel, then hardened and the punch set on it with a hammer. As say in fig. 2, when *B* is a bed of soft steel faced off and polished (fine emery paper is fine enough). We take a hollow punch with a vertical section as shown at *G* (magnified), and punch the face *B* into innumerable little rings

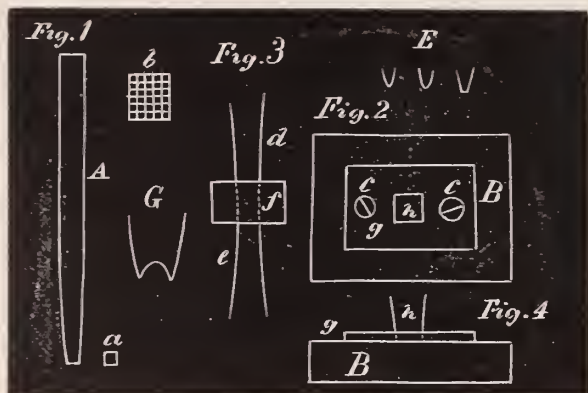

overlapping and intersecting each other, using care to have the punch penetrate *B* to about the same depth. We now fit a plate with two screws shown at *c c*; this plate has a hole through it which will just admit the end of the punch *h* as shown in fig. 4, which is a vertical section of fig. 2. The bed *B* should now be hardened and the punch *h*, fig. 4, should be driven through the hole in *g* (which it exactly fits and serves as a guide) until a perfect rivus impress is made on *h*, when it should be hardened and used for matting. The size of the circle of the hollow punch should be about  $\frac{1}{16}$  or  $\frac{1}{8}$  of an inch. A method of reversing punches is shown in fig. 3, where *f* represents a piece of steel about  $\frac{1}{8}$  of an inch thick in which a square mortise of the size of the punches is made. Punches with irregular faces are made by leaving the steel of the full size (say  $\frac{1}{8}$ ), and cutting the pattern on with the graver and then filing the end down to (say  $\frac{1}{16}$ ). This method is better than to try and cut the pattern on the punch of the right size at first, as it is not pleasant to start a graver at the extreme edge. In using colored gold for such a job as was illustrated in last number, I gave a method of flattening small pieces with a hammer, as one seldom wants, except in large manufactories, colored gold except in small bits. If, as in our last issue, we used colored gold (green) for the leaves and some other contracting color for the vine, and matted the back or recessed ground a fine effect would be produced. On the other hand, if the

leaves and vine were merely cut and relieved from the ring, the sunk portion must be cut away with gravers of suitable forms. Gravers of the form shown in cross section at *E* being preferable. I will say a few words about coloring. The writer feels a good deal of diffidence in speaking on this subject, as many processes have been given in this journal, some excellent, others of questionable merit. But the writer has in his experience found that circumstances often modify results, and processes which succeed in some hands fail in others. In coloring, the reader should start with the knowledge that coloring, as it is generally termed, is only destroying the alloy in the surface of the article of jewelry in hand, and leaving a surface of pure gold with more or less brilliancy and sparkle. As a rule articles below 14-k. do not come out as fine as those above this fineness. Indeed the finest articles of colored gold (in appearance) which have come under my notice were of 18-k. and colored by the so-called dry process. Still, very beautiful goods are made and colored by the German wet process as low in quality as 11-k. But the ordinary jeweler is apt to scold when he attempts to mend with hard solder such work, and seldom restores the color except with the battery. Most of the coloring is done with mixtures of common salts, alum and saltpeter. The so-called dry coloring is done by a mixture of the following ingredients:

- Salt peter.....8 oz.
- Alum.....4 oz.
- Common salt.....4 oz.

Pulverize and mix the above and put in a porcelain dish. Some of the substances named above contain what is called water of crystallization, and although appearing dry will, on the application of heat, seem to melt and form a liquid. This mixture heated and stirred with an iron wire will at a certain temperature rise; now is the time to insert the articles to be colored suspended on a silver wire; the articles to be colored should be moved around in the color until there is noticed a tendency of the color bath to sink when the articles should be removed and dipped in muriatic acid pickle. Two or three dips will give the desired color. In coloring with the above the goods must be 18-k. or above, perfectly polished and free from all grease. Washing with hot water and washing soda or boiling in borax water will effect the removal of grease, and careful buffing will produce the proper polish. The washing should, of course, be the last thing done before coloring. In drying, hot box-wood sawdust should be used, but this should be carefully removed as any particle of sawdust will produce a black spot on the job. No exact rules can be given but a little practice with the above instructions will enable one to color well. The so-called wet process is as follows:

- Salt peter.....14 oz.
- Common salt.....7 oz.

Pulverize and put in a block lead color pot about 7 inches deep and 6 inches across the top; heat the mixture and stir with a wooden spatula until all the water of crystallization is removed, and the mixture of salt and saltpeter is a dry, hot powder. Now add 5 ounces of muriatic acid. The color will soon boil up and is now ready for the jobs, which should be well polished and cleaned as above directed. An immersion of 3 minutes in the color pot (when it should be moved about), will be about the right length of time when the jobs should be removed, and dipped and rinsed in boiling water. Now add 2 ounces of boiling water to the color pot and when it boils up immerse the job for one minute, when the work can be removed and well washed in boiling water. The work can be finished by scratch brushing with weak ale. Now, all this reads very simple and so it is to the experienced man, but *greenhorns* must expect failures. But with the following precautions the art can soon be acquired. The alloy (as low as 12-k. and up to 18-k.), must not contain *too much copper*, but should be of at least equal parts silver and copper. A fine polish on the articles. Thorough and perfect cleanliness and freedom from grease. In the manufacture of low karat articles it should be remembered that the goods should be made a trifle heavier than if of 18-k. as the coloring dissolves the alloy to an appreciable depth.



## Foreign Gossip.

—The Japanese style of engraving on waiters is much in vogue in Europe. Those of the commoner class bear stamped impressions of Japanese work, and correct taste will be bound to admit that they are exceedingly pretty, though, of course, they do not possess that fineness of touch which characterizes the hand-worked specimen.

**CUT GLASS THRONE.**—Perhaps the finest and most elaborate piece of cut glassware ever made is a throne manufactured for some East Indian prince by an English firm. A dome-shaped canopy in the form of a star is borne by pillars supported upon the back and arms of the throne. Every portion of the surface has been cut, the pine-shaped finials surmounting the arms having no fewer than 324 facets. The ornamentation of the dome is especially elaborate, and as it is at present illumined by two incandescent lamps, which are fixed beneath it, it sparkles like a gigantic diamond.

**PERSONAL.**—Sir William Thompson, Professor at the University of Glasgow and after Helmholtz, perhaps the greatest physicist of the present age, has, at the instigation of the Dubois-Reymonds of the Berlin Academy of Sciences, been proposed and confirmed by the emperor as a foreign knight of the order for merit. Thompson interested himself greatly in the transatlantic telegraphy. He is the inventor of the most remarkable invention of the age—the mirror galvanometer, and was, perhaps, the foremost scientist engaged in the laying and reducing into working order the first Atlantic cable, in 1866, for which purposes he was knighted.

**LARGE ORGAN.**—The largest organ probably ever constructed was lately completed at Ludwigsburg. It is destined for the cathedral church at Riga. It contains 7,000 pipes, 124 stops with pedals, etc., proportionately numerous. A very complete "swell" arrangement allows the increase and diminution of sound to be effected with singular perfection and delicacy of effects. The filling of the pipes could not be carried out by organ blowers, but is effected by machinery worked by a gas engine of 4 horse power. The organ is 20 meters high, 11 broad and 10 deep (about 65½ ft., 36 ft. and 33 ft. respectively). The largest wooden pipe is 10 meters (32¾ ft. high, and its cubic contents are 70.6 cubic feet; while the smallest pipe is only a centimeter and a half (little more than half an inch) high, and is attached to the greatest one. We believe that the large electric organ at Garden City, Long Island, contains 7,031 pipes and 115 speaking stops; but as that instrument is distributed in four parts of the cathedral, we suppose the Riga organ will henceforward rank as the largest in the world.

**THE CARDIFF GIGANTIC PEARL.**—Cardiff, England, which, years ago furnished the "Cardiff Giant" of notorious memory, comes again to the front, this time, however, with a "giant pearl," of an intrinsic value of \$100,000. A correspondent of an English paper says that the pearl is about to be placed in the Art Exhibition, and some facts explaining its find will be of interest. The lucky owner, Mr. Rawlins, is a resident of Thomastown, and in common with his townsmen owns a small garden. Two years ago, it appears, a large quantity of oysters came to Merthyr from Grimsby, consigned to a local fishmonger; but for these the sale was not rapid enough to clear them off while they were fresh, and in consequence several barrels remained on hand in a condition which unfitted them for the table. The fishmonger saw Mr. Rawlins, and, knowing that he was an amateur gardener, asked him to buy a barrel for manure. This he consented to do and had the barrel taken up to his garden. In the winter the oysters were thrown up and Mr. Rawlins noticed something peculiar in the one in question, and thinking that the weather might act upon it he placed it under a currant bush where it remained for months; and then seeing that the seeming pearl was as white and firm as ever, brought it into town and exhibited it to some of the principal inhabitants.

**POTATO BUTTONS.**—Paul Friessbach, of Curow, near Zelasen, has patented an invention for manufacturing buttons and other small articles from the refuse fiber of potatoes after the starch has been extracted from it. The wastage is collected in tubs, and, after being subjected to the continual influence of a suitable mixing and stirring operation, raised to a temperature of 76 or 79° C., after which the strong, thick pulp thereby produced is poured into moulds and subjected to a strong pressure. The durability of the substance is still increased by adding a certain quantity of acid, to eliminate any traces of starch still remaining in it; this is not indispensably necessary however.

**PRECIOUS STONES.**—There is a peculiar poetry attached to many of the names of the old gems; aquamarine (sea water) tells how its lovers idolized it; another name for topaz is "goutte d'eau;" the garnet (granat) borrowed its appellation from the pomegrante, whose seed its color resembles, and one of its ancient names was arthrae (a burning coal); light, clear garnets were once called hyacinths, and so were the crystals of zircon and the cinnamon stone from Ceylon; and the moonstone or ancient selenite was called "moon-froth;" and the peristerite, a cousin of the moonstone, as aventurine is also, gets its name from its slightly iridescent colors like the pigeon's neck. The name of diamond is a corruption of the Greek word "adamas" (hard), and no fancy has been able to throw a halo of poetry around it. It has the hard luster of the dollar of which it is simply a representative.

**GOLDSMITH'S EXHIBITION IN PESTH.**—An exhibition of rare goldsmith's work has been opened in Pesth, in the rooms of the National Museum. Among the exhibits there are some richly jeweled crowns of historical interest and a number of pyxes, chalices and other ecclesiastical objects, some of which are of immense value. The bulk of the exhibition consists of valuable gold plate and personal jewelry, either of Hungarian manufacture or the property of the old Hungarian families. The principal objects have been lent by the Imperial "Schatzkammer" at Vienna, and by the various archdukes, magnates and ecclesiastics, and a few have come from abroad. Among the crowns is one set with pearls with which King Ladislaus and the great Mathias Corvinus were crowned; and the so-called "funeral crowns" of King Bela III. and his wife Anica, of Antioch, found in their graves at Pressburg. There are also several pieces of enamel from the crown of the Emperor Constantine Monomachus, bearing portraits of the emperor, his wife, his sisters and two dancing girls; and a crown discovered in the last century during excavations made at Grosswardein for fortification purposes, and whose origin is uncertain. Another remarkable exhibit is the so-called exchequer of the Gothic King, Atanarich, consisting of a number of golden cups and vases, weighing 2,400 ducats, discovered at Torontal. Amongst the ecclesiastical articles are the pyx and chalice presented by the Hungarian King, Louis of Anjou, to the Chapter of Aix-la-Chapelle in 1340, and now lent by it; further, a huge golden crest of King Ladislaus, crowned, from the high altar of the cathedral in Raab; besides about thirty golden chalices from the time of Mathias Corvinus, when the goldsmith's art in Hungary was at its height. There is, further, a golden cup richly set with jewels, which possesses a remarkable history. It was given in 1598 to Count Nicolous Palfy by the Austrian States, for services rendered in the re-conquest of Raab from the Turks. This cup, which weighs 1,000 ducats, and is still more valuable for its rare artist merit, was afterward given by a son of this Nicolous Palfy as ransom to extricate his father from the hands of the Croats who had made him prisoner. It thus came into possession of the Sultan, and was eventually presented to the Austrian Emperor Leopold, who, recognizing the arms of the Palfy's on it, restored it to the family. The catalogue, which will itself form a handbook of great interest, has been drawn up by M. Pulzky, Director of the Pesth National Museum, and his son, Karl Pulzky, Director of the Esterhazy Gallery in Pesth, who together planned and arranged the Exhibition.

## Trade Gossip.

Opals are coming into fashion again.

Diamonds with a slight blue tinge are as popular as ever.

Many new and beautiful designs are offered in onyx jewelry.

Diamonds in settings fitting close to the ear are popular.

Turquoise set with small pearls are extensively used in lace pins.

Alligator teeth are made up into bangles, ear rings, scarf pins, etc.

Hess & Schleisser have removed to 2 John street, corner of Broadway.

Glove rings with the surface closely studded with rose diamonds is the latest agony.

Sea shell jewelry is growing in public favor. Its sale is confined to the bazaars and fancy stores.

Messrs. Taylor & Brother are now comfortably settled in their new business house, No. 860 Broadway.

Joseph F. Chatellier's new rosette style of gold jewelry recently patented by him is rapidly growing in public favor.

The firm of Condon & Volk, of Ocala, Fla., has been dissolved by mutual consent. W. W. Condon will continue the business.

H. Schnurbusch, who claimed to be a ringmaker, left suddenly for parts unknown, leaving a number of victims to mourn their loss.

Messrs. F. I. Marcy & Co. has lately introduced a series of very artistic designs of classical subjects in coin silver "lever" cuff buttons.

N. C. Toepfert, formerly of Cincinnati, has made a business engagement with the F. B. Rogers Silverware and Cutlery Manufacturing Co. of Boston.

H. J. King, an old and well known traveler of this city, has entered into a business engagement with the F. B. Rogers Silverware and Cutlery Manufacturing Co.

Wm. M. Fisher & Co.'s patent oval split ring is a great success. It is meeting with a ready sale and is spoken of in the highest terms of praise by all who have handled them.

Henry C. Haskell has introduced many novelties in silver jewelry, consisting of bangles, hair ornaments, etc. The designs are novel and attractive and must prove popular in the trade.

Edward Keeler who was arrested some time since for complicity in the Hayden jewelry store robbery at Brooklyn has been convicted. His address for the next two and a half years will be Sing Sing.

Oscar Heyer, a jeweler of Wilkesbarre, Pa., is reported to have been robbed of a quantity of jewelry, diamonds, etc., valued at \$1,200. The alleged thief is said to have been arrested with the goods in his possession.

Another enormous diamond is reported to have been unearthed at the Kimberley mines. An octohedron measuring  $1\frac{3}{4}$  inches in length and only half an inch less in its shorter diameter, and weighing 302 karats.

The American Watch Company has sold to the Naval Observatory at Washington, one of their finest sixteen size watches in one of their dust proof cases. It is to be used for astronomical purposes in the Greeley Relief Expedition.

Henry Abbott's patent stem winding device has achieved a great success. It is endorsed by many of the best workmen in the country, and the number of flattering testimonials received by him testifying to its superiority in unmeasured terms of praise would fill several pages of THE CIRCULAR.

At the last meeting of the New York Jewelers' Club it was decided to hold their annual re-union at Coney Island on July 1st. This year the New York Club will entertain the New England Manufacturing Jewelers' Association, and are arranging their entertainment in as fitting and enjoyable manner as possible.

Col. A. Andrews, a gentleman well known in the jewelry trade in San Francisco, has been appointed by President Arthur as a representative for California, at the World's Industrial and Cotton Exposition to open in New Orleans in December. The appointment was made on the recommendation of Gov. Stoneman, and the commission, duly signed by the President and Secretary of State, bears date February 9, 1884.

Edward Schrivener, a young man employed in one of the leading jewelry establishments in Dayton, Ohio, was recently arrested at the instance of his employers, charged with robbing them of some \$4,000 worth of jewelry and watches which were found secreted in his room. Some of the articles were among the finest in the store.

At a large meeting held a short time ago at Jerusalem, the president, a bishop, drew attention to the fact that most old customs were being revived, as instanced by the majority of the English ladies present wearing nose rings similar to the ancient Jews, and he also stated they were being most rapidly adopted by the European and American ladies visiting the city.

The Bavarian Museum of Industrial Arts in Nuremberg will hold an international exhibition of gold and silversmiths' works, jewelry, and bronzes, from June 15 till Sept. 30, 1885, under the auspices of the King of Bavaria. The Department of State has received a communication inviting individuals and firms engaged in these industrial arts in the United States to participate in the exhibition.

The finest rubies are found in Ava, Siam and Peru; others are found in India, Ceylon, Australia, Borneo and Sumatra. The Burmese mines have long been famous; the working of them is a royal monopoly, and the King has among other titles that of Lord of the Rubies. The Brazilian ruby is declared to be a pink topaz, inferior to the true ruby, yellow in its natural state, and colored artificially.

L. Hammel & Co. have just introduced a new lathe wheel called the "Ideal" of which they hold the patent. It is devised for the especial purpose of overcoming the "dead center," which it does perfectly, thus giving the workman greater facility for doing his work. The firm claim that a 30 pound wheel of this pattern will do as much work and more easily than the ordinary 50 pound wheel. Its attractive features are fully set forth in their new catalogue.

Joseph Bailey, of Bailey, Banks & Biddle, of Philadelphia, left for Europe Saturday, the 10th ult. Stephen C. Howard, of Howard & Son, left in the *Celtic* May 3. A. Pinover, of A. Pinover & Co., left in the *Werra* May 14. Aug. Kurtzeborn, of the L. Bauman Jewelry Co., St. Louis, accompanied by his wife sailed in the *Werra*. Mr. Daniel F. Appleton, of Messrs. Robbins & Appleton, general agents of the American Watch Co., sailed on the 14th in the *Servia*.

John Kister, a dangerous burglar who has served ten years of a thirty years term in the state prison at Trenton, N. J., has fallen heir to \$60,000 left him by a relative in Devonshire, England. The convict was a confederate of Red Leary and other infamous cracksmen, and had figured prominently in several daring jewelry store robberies. Kister was finally captured and sentenced to 30 years' imprisonment for the robbery of Krementz & Co.'s factory at Newark, N. J.

Richards & Rose, successors of F. Jenkel, of Dubuque, Iowa, lately deceased, have opened with a desirable stock of new goods selected with care and discrimination. Mr. Richards was for many years the editor and proprietor of the Freeport, Ill., *Daily Journal*, and Mr. Rose enjoys the reputation of being one of the best watchmakers in the State. The young firm commence business under the most favorable auspices, and propose to conduct their affairs on strict business principles.

Mr. Mat Irion, of Louisville, was recently "done out of three ladies' watches by a sleek scoundrel who persuaded the jeweler to send the watches to a designated house to be inspected by the ladies. On his way to dinner a clerk left the watches at the number designated, but in a few minutes the sleek rascal called for them, explaining to the servant that they had been left by mistake. When the clerk returned for the package the swindle was discovered, but the watches were gone beyond recovery.

The old house of Palmer, Bachelder & Co., of Boston, has been compelled to make an assignment for the benefit of the creditors. Their liabilities amount to \$183,000 and nominal assets to \$170,000; the latter when brought to market it is estimated will probably realize about \$75,000. This failure was not wholly unexpected, for it has long been felt in the trade that the firm was putting off present pain for distant death. Not one word can be said prejudicial to the integrity of this firm; the unfortunate members have given up everything to their creditors after a long and manful struggle against the inevitable, succumbing only when they deemed it dishonorable to go further. The affairs of the firm are now in the hands of a committee of the creditors, who have none but the kindest feelings towards them, and will doubtless extend to them every assistance consistent with the interests of the trade.

Col. J. M. Rutherford, the eloquent jewelry auctioneer, has been knocked completely out of time by one of the light-fingered gentry, while a guest of the Luzerne House at Wilkesbarre, Pa. The watch is described as a 14 karat gold plain, flat hunting case watch. P. S. Bartlett, nickel movement, also Masonic mark with name on, J. M. Rutherford, Philadelphia Keystone Lodge, No. 271. Oriental Chapter, No. 183, with curb chain attached. A liberal reward is offered for the recovery of the stolen property by the chief of police of that city.

J. B. Trickly & Co., of Lincoln, Nebraska, have just moved into their new store No. 1025 O street, which they have fitted up in an elegant and substantial manner, and with every requisite for conducting a legitimate jewelry business. The artistic effects exhibited in the arrangement of cases and interior decorations reflect great credit on the good taste of the proprietors. The show cases are well filled with the latest and newest designs of jewelry, a full line of clocks, watches, silver and plated ware, and articles of vertu and ormolu.

It is estimated that there are 45,000 workmen engaged in the watch industry of Switzerland. In some cantons the manufacture of cheap imitation gold and silver watches has been recently started. A composition is used in the manufacture of these imitation metals which is so highly explosive that a slight blow will cause a detonation of an alarming character. Excellent horological schools are established throughout the country in which boys are taught the trade of watchmaking in all its branches by the most skillful workmen to be found.

S. B. Boynton, of Milwaukee, is reported to have recently found two small diamonds in a gravel strata near Waukesha. One of the stones is said to be a fine specimen, the other an imperfect crystallization known as "tart" diamond. At a depth of fifty-five feet the diggers came upon a piece of timber, evidently tamarack, perfectly preserved; it had probably lain in its present bed for thousands of years and was not petrified. In the upper strata of gravel Boynton found quantities of topaz, stones, malachites, sardonyx, chrysolites, cornelians and pieces of garnet.

A well known member of the trade was among the unfortunate depositors in the Marine Bank, losing several thousand dollars by its failure. But he turned his misfortune to good account. He had a fac-simile of a Marine Bank check printed with a mourning border around it, inscribed with the sad legend "we mourn our loss." These he sent out to his customers with statements of their accounts, and the result was that his remittances were never so prompt and liberal. Some customers who had been classified as "lame ducks" came forward with their payments on seeing this signal of distress. It was a good idea and worked well.

We have to report another failure in the trade, J. S. Wilkins & Co., of Memphis, having failed under circumstances very different from those surrounding the firm of Palmer, Bachelder & Co., of Boston, elsewhere referred to. The liabilities of Wilkins & Co. are estimated at \$40,000, distributed mostly among New York creditors. This firm enjoyed confidence and credit in New York to a remarkable degree, and their failure is a matter of great surprise to everybody. The affairs of the firm are in a somewhat chaotic condition owing to the disappearance of Mr. Wilkins at the time when his services were most needed to straighten out matters.

We have received several letters complaining of the transactions of E. P. Tiffany & Co., of 195 Fulton street. This firm was in the habit of soliciting orders from the country for jewelry, receiving the money and never sending either goods or money in return. Finally the firm sold their business through alleged misrepresentation to I. A. Smith for \$2,500 and then left the State. When Mr. Smith found out that he had been swindled, he was obliged to make an assignment to J. M. Chapman, who announces that the assets are between \$700 and \$800 of which \$600 is preferred. This bogus firm of Tiffany & Co. did quite an extensive business, as country people supposed they were dealing with the old and well known house of Tiffany & Co., of Union Square. This latter firm received many letters of complaint, and the police and postal authorities were notified of the swindling transactions of E. P. Tiffany & Co., but the birds had flown before they could be arrested. It is an old trick of adventurers to copy as nearly as they dare the name of some well known firm and delude the public with bogus wares or swindling schemes. Such rascals are classed in the same category as "sawdust swindlers" and "bunco steerers," and as it is impossible to forewarn the public regarding each one, it is necessary to be constantly on the alert for them and expose them when they are found out.

An interesting example of the patient ingenuity of a skilled mechanic, is a perfect reproduction of a locomotive made by Mr. Case, a watchmaker of Franklin, Penn. From the point of the cow-catcher to the end of the tank it is six and one-fourth inches long and weighs two pounds. It is finished in gold, silver and steel, and to the most minute part is a perfect locomotive. Mr. Case has spent four years in building it. It makes its own steam, pumps water into the boiler, has a throttle valve, bell, sand box, and, in fact, lacks nothing found in a first-class locomotive. Many locomotive engineers have examined it and they pronounce it perfect. Mr. Case will have a miniature track built and place it on exhibition at the Cotton Centennial Exhibition in New Orleans.

Leah Ahlborn, a famous die sinker of the Royal Mint at Stockholm, has accepted the commission to cut the dies for the medal struck to commemorate the erection of the Washington statue in Wall street, which is to be issued under the auspices of the American Numismatic and Archæological Society and the New York Chamber of Commerce. This artist is perhaps the finest medalist of the age. Her latest work commemorates the silver wedding of the King and Queen of Sweden. She also cut the dies for the Henry Stanley medal. The idea of the Washington medal is due to the public spirit of the Hon. Algernon S. Sullivan. C. L. Tiffany, Augustus St. Gaudens and G. L. Feuardent, the committee appointed to select a design—and a better committee it would be hard to find—decided on the one submitted by the Whiting Manufacturing Co.

A short time ago a neatly dressed swindler, about 35 years of age, went into Hayden & Stanwood's jewelry store in Brooklyn, and said that he wanted to see some ladies' neck chains. He was shown three long double chains which are valued at \$100. He examined them and said: "I want my mother to decide, as the present is for her daughter; if you will send them to Mrs. Sheldon at 124 Pierrepont street, she will make a selection and pay your messenger." The jewelers found that there was a Mrs. Sheldon living at the number given, and sent a boy with the chains. He delivered them and Mrs. Sheldon was surprised, but said to him: "I suppose my son sent them. It is all right." As soon as the boy left, the swindler, who had been watching him, rang the bell of Mrs. Sheldon's residence and asked for her. When she came he said: "I am sorry, madam, but Messrs. Hayden & Stanwood, by mistake, have sent three chains to this address. They have mistaken the number and sent me for the property." Mrs. Sheldon gave him the chains and the adroit swindler escaped with them. The detectives are looking out for him.

Rubies and pearls are now the most fashionable gems worn. The finest rubies come from Ceylon and Siam. They are more expensive than diamonds of the same size owing to their scarcity. The standard color for a ruby is pigeon blood, but there are very few perfect specimens. Pearls are white, black, gray and bronze. A good many of the colored pearls come from Panama. Black pearls are rare, and after all are not jet black but a sort of smoky hue. The finest white pearls come from Australia. We have pink pearls also. The best opals come from Hungary, but opals sell rather poorly now though a trifle better in popular favor than a few years ago. The Empress Eugenie in her time did much to discourage the sale of the opal, as she subscribed to the superstition that it is the "Mother of Sorrows." The Central American opal is affected by heat, so that if it has a seam it will be likely to split. As to the sapphire more reasonable prices prevail now, due to the discovery of a new mine in Ceylon. The color of the stone found there is lighter than that at Burmah, but it is more brilliant. There are imitations of sapphires and emeralds, and the French imitate pearls also in a composition that almost defies detection by the untrained eye.

An important case interesting to jewelers has recently been tried in the courts. Mrs. Roebing, wife of the Chief Engineer of the Brooklyn Bridge, sued the Adams Express Company and Tiffany & Co. for the loss of diamond ear drops worth \$3,000, which she had purchased of Tiffany & Co. and sent to them to be repaired, with directions to send the jewels to her at Litchfield, Connecticut. In her complaint she alleged that the package was lost through the negligence of the express company. Tiffany & Co., she urged, were jointly liable, having agreed that they would properly repair said earrings, and then send them by express to the plaintiff properly and in a business manner. Chief Judge Sedgwick, in the Superior Court sustained Tiffany & Co.'s demurrer to the complaint, holding that it was defective in not alleging or showing that it was a part of the sending by the express company or of a business manner, to put upon the package a mark or indication of its value, or to recognize and comply with the rules and regulations of the express company, or that the doing of these things or either of them was suitable, proper and their duty to insure the safe and prompt delivery to the plaintiff. Leave was given to amend the complaint on payment of costs.

Waltham is quite an energetic town for its size and emulous of distinction. Barnum recently imported a sacred white elephant and Waltham does not like to be outdone. But white elephants of the sacred variety are scarce, and as Waltham can no more hope to succeed in getting a genuine one than Forepaugh did to pit against Barnum, so Waltham feels impelled to do as Forepaugh did and get up an imitation. This imitation may turn out to be an elephant or a watch company, but at present it is put down in the bills as a watch company. Waltham already has one successful watch company, the American, the largest in the world, but this has got to be an old story and Waltham wants a sensation. So a new watch company is announced as undergoing the incubating process; it is to outdo every other effort in this line, manufacturing movements of all grades from the highest to the lowest, but will keep the market fully supplied with movements of some kind. The capital with which it will start is variously stated at from \$100,000 to \$3,000,000, according to the degree of credulity manifested by the listener. From information given us we are led to believe that the munificent sum of about \$50,000 has actually been promised to further an enterprise of this kind in Waltham, but that this sum would be but as a drop in the bucket no one knows better than the projector. We commend to the would-be stockholders in this concern the lesson taught by the experience of the Lancaster Company as outlined in another paragraph.

When a visitor to the office of the American Bank Note Company sat down to talk to Mr. Lee, that gentleman put a piece of white paper under a stamp, pounded on it and laid the paper aside. When the visitor arose to go away Mr. Lee put the paper under the stamp again and pounded it once more. "You talked eight minutes," said he; "that wasn't bad." He showed the piece of paper to the caller who saw upon it two printed clock dials. One showed the hands at four minutes to 4 o'clock, the other showed them at four minutes past 4 o'clock. "We keep that stamp," he said, "so that you shan't go away and say you came here at 11 o'clock in the morning, or that you had to wait an hour and a half, or make any other misstatements which can be guarded against. No," he added a moment later; "that stamp is the latest wrinkle in office furniture. It is an ordinary stamp with a clock attachment. The hour hand is simply a raised point upon a movable circle. The minute hand is an arrow upon another revolving circle. The usual inked tape passes over these indicators and the outer circle of hour figures. Beside the clock face is a cylinder with several faces, each bearing a word—one is 'approved,' another is 'wired,' another is 'answered,' others are 'delivered,' 'Lee,' 'received.' Thus a business man is able whenever he sends away a letter, telegram or package, receives an order or transacts any business whatever, to record the precise moment at which the thing was done. It costs \$20. I did not invent it. I bought it."

The General Term of the Superior Court at Binghamton, N. Y., has affirmed the judgment and conviction in the case of Chas. Mayhon, one of the thieves implicated in the robbery of the Ellenville jewelry store, in which several thousand dollars worth of jewelry was stolen. Mayhon is a professional New York burglar, and, in company with John Moore and Patrick Cody, two other expert cracksmen from New York, planned and successfully carried out the burglary. Cody was captured the day afterward. Mayhon and Moore were arrested by Pinkerton in November and brought to Ulster county, where they were tried. They were defended by the Hon. F. L. Westbrook, ex-member of Congress, Charles Pelham, of Alabama, and William W. Betts, of Washington. The trial lasted two weeks and attracted much attention because of the prisoners being both well known throughout the United States and the Canadas and because of an assault made by one of their counsel, Col. Betts, upon District Attorney Clearwater, who conducted the prosecution. They were both convicted and sentenced to imprisonment in the State prison at Dannemora for five years and both appealed. The appeal was recently argued at Binghamton by Mr. Westbrook for Mayhon, and District Attorney Clearwater for the people. Moore's appeal has not yet been argued. All three prisoners have served several terms of imprisonment in various States and in Canada, and are regarded as three of the most dangerous and skillful burglars in America. The news of the affirming of the conviction has given general satisfaction to the trade here.

Every little while the jewelry trade is attempted to be victimized by strikers in the legislature or by lobbyists who claim to control the members. At Albany, this winter, a bill was introduced requiring the stamping of all jewelry. It was attacked by Mr. Henry Heath, member from Brooklyn, and was laid on the table as was supposed for the session. But just before the close it was called up and, in the confusion, was being rapidly put to vote, members voting aye without knowing what the measure was, when Mr. Heath again called attention to its objectionable features in which he was seconded by Mr. Roosevelt. The result was that members who had voted for it changed their votes and the bill was killed. There are always presented to the legislature bills of this character, intended to provide easy places and fat salaries for a lot of political strikers, and they are apt to slip through at the close of a session unless some one is on the alert to hit them on the head as they come up. It was a close shave for the bill referred to, and the thanks of the trade are due Mr. Heath for having killed it so promptly. The chances are that this same bill will be presented next winter by some flannel mouth statesman, and the trade should see that they have a representative in the legislature who will look after this and other vicious schemes.

The sea bean is being largely used now in making various articles of jewelry, for which it is excellently adapted as it takes a very high polish, and, being very hard, is not easily broken. In fact, its hardness is remarkable, being of the character of flint, so that the strongest tools are required to cut and polish it. In former years a class of artisans in Florida did a thriving business in making various personal ornaments out of it, for the numerous tourists and visitors from the North and other sections who are always to be found in Florida, and the trinkets were carried away as relics, articles of curio, etc. Now sea bean jewelry is made the basis of a profitable industry by Northern capitalists and is worn considerably in all sections. It is seen in watch charms, ear rings, scarf pins, cuff buttons, etc. For watch charms the bean is set with a miniature compass or engraved with an initial, emblem or some fancy design. Some are mounted with gold balls making them more expensive. The large flat beans are polished with emery, pumice stone and the polishing lathe, and engraved with some peculiar design, and the lines of the engraving are made to contrast with the dark color of the bean by white enamel which is rubbed into them. The article is then mounted on an easel, and thus serves as a curio or fancy piece for the mantel or bric-à-brac case.

In THE CIRCULAR of last month allusion was made to the fact that the Lancaster Watch Company had been re-organized, and would hereafter be known as the Keystone Watch Company. The history of this company has been similar to that of almost every other company of the kind that has been organized with insufficient capital. It was first started in 1874, and was known as the Adams & Perry Watch Company. After running two years and sinking upwards of \$125,000, the company made an assignment for the benefit of its creditors. In 1877 it was re-organized as the Lancaster Watch Company, limited, but the stockholders became disheartened, took in new capital and again re-organized in 1878. The new stockholders being called upon for assessments, entered into a lease with some of the stockholders who formed another company; they in turn got tired and amalgamated with the other company, forming the Lancaster Company that went out of existence recently. This company found it up hill business to run a watch factory without plenty of capital, and having got into debt to the extent of \$100,000, a number of the largest stockholders made a proposition to Abraham Bitner who had been the superintendent, to make him a present of their interest in the concern if he would assume the indebtedness. This he agreed to do giving security to that effect. He then bought some other stock at ten cents on the dollar, and thus became the owner of 5,625 shares of stock out of 8,000. The company was re-organized and called the Keystone Watch Company, and as such is to be known hereafter. Mr. Bitner at once came to New York and made a contract with Oppenheimer Bros. & Veith to take all the watches manufactured and in process of manufacture owned by the company, and the factory is now employed in filling this contract, and some 1,500 movements have already been sent to the New York firm. During these ten years of its existence and through all the changes of its organization, the stockholders never received a dividend, but, on the contrary, were quite frequently called on to pay assessments. Mr. Bitner having secured the plant at a nominal cost bids fair to make something out of it, and to realize a handsome sum from his bold and venturesome investment.



VOLUME XV.

NEW YORK, JULY, 1884.

No. 6.

## THE JEWELERS' CIRCULAR AND HOROLOGICAL REVIEW

*The recognized organ of the Trade, and the official representative of the  
Jewelers' League.*

A Monthly Journal devoted to the interests of Watchmakers, Jewelers, Silver-smiths, Electro-plate Manufacturers, and those engaged in the kindred branches of art industry.

### SUBSCRIPTION:

To All Parts of the United States and Canada,  
**\$2.00 Per Annum; Postage paid.**

To Great Britain, France, Switzerland, Germany, the West Indies, Mexico, the Republics of South America, and Australia, \$3.00 per annum. Postage paid.

*All communications should be addressed to D. H. HOPKINSON, 42 Nassau Street, New York. Advertising rates made known on application.*

### The Retail Jewelry Trade.

THE RECENT financial crash among criminal speculators and bank officers in Wall street was scarcely felt in legitimate business circles. Only two banks failed, and the operations of these were confined to dealings in speculative securities almost entirely, and comparatively few regular business houses were found among their depositors. The fact that such large failures should occur, involving millions of dollars of speculative values, without causing widespread financial stringency, is a sure indication that the general business of the country is in a sound, healthy condition, and is not to be affected by the visionary transactions of the Wall street gamblers. There has been a tendency during the past two years to place the business interests of the country on a good substantial basis. It was evident to every thinking man in 1881 that the prosperity that apparently existed at that time was largely fictitious and based on a speculative estimate of values; there seemed to be an abundance of money and business "boomed." But it was evident that the water had got to be squeezed out of speculative stocks and matters in general brought to hard pan. Many persons predicted that a panic like that of 1857 or 1873 would be required to do this, but there has been no collapse of any great enterprise to precipitate such a panic. Instead liquidation has been going on slowly but steadily; railroad stocks have depreciated largely, securities of all kinds have fallen off, and while there has been a shrinkage in values greater than occurred in 1873, the process has been so gradual that it has scarcely been perceptible, or, at least, it has been met without bringing about a universal crash. During this process of liquidation there has ensued a period of dullness in general business which has enabled business men to put their affairs in order, so that when the crash of speculators and thieves occurred in Wall street so recently few honest men were hurt by it.

In the jewelry trade the effects of these Wall street disasters were scarcely perceptible. Not a single failure has been reported to have

occurred in consequence of them, nor do they appear to have embarrassed the trade in any manner. Some large manufacturers, who require large sums to carry on their business, may have found the money market a little tight for a day or two, but their embarrassment amounted to little compared to the general interests of the trade which did not suffer to any appreciable extent. This is certainly highly creditable to all concerned, for the jewelry trade has heretofore been peculiarly sensitive to fluctuations in the money market, and anything like a panic has been sure to be marked by the wrecks of many jewelry firms. That there have been recent failures is true, but so far this year manufacturers have not been called upon to attend meetings of creditors as frequently as in former years, nor has one occurred for which Wall street has been responsible. The element of fraud, too, has appeared in fewer cases of failures than usual, and, although there have been one or two suspicious failures, the most of them have been the result of legitimate causes. That the Wall street crash will have a tendency for a time to make business dull is inevitable, for men will be more or less suspicious and cautious in their dealings, and the retail trade will be affected in common with every other branch of legitimate industry, but a few weeks will serve to clear the atmosphere and the country will be the better for having punctured this speculative bladder.

A few years ago such a financial excitement as recently occurred would have been seriously felt in the jewelry trade, for far looser business methods prevailed than at present. During the past five or six years there has been a decided improvement among retail dealers in their business transactions. They are far better merchants, buy with greater judgment, pay more promptly, have less encumbrance upon their stocks, and have, consequently, a more direct interest in getting the most possible out of them. They have at last begun to realize the fact that prompt payments are necessary to the maintenance of good commercial standing, and that such standing gives them many advantages in buying goods. It takes ambitious young men usually some time to realize that goods purchased on credit do not belong to them absolutely until they are paid for, and they are apt to regard all money that comes in for the sale of goods as available for the payment of personal expenses. The fact that outstanding paper is rapidly maturing is lost sight of too frequently till notice is received that it must be provided for. It was a shrewd financier who remarked that nothing made time pass so quickly as a note maturing in the bank. It is greatly to the credit of the retail trade that this indifference to maturing obligations is becoming a thing of the past, and prompt payments more nearly the rule. Dealers are buying goods, too, with more circumspection and judgment, declining to overstock themselves with unsalable goods, but buying what they want at such times as they need. Commercial travelers afford them every facility for doing this, and through them the dealer can always fill up his broken lines and freshen up his stock with the latest novelties. Reports from travelers, however, show that dealers are growing extremely cautious in ordering through them, and it is with difficulty they can be persuaded even to accept

credit for goods they actually need, so fearful have they grown of incurring indebtedness beyond their ability to pay. While this shows a healthy state of mind on the part of the dealer, it is rather rough on the travelers whose reputations are dependent upon the amount of their sales. There are indications that the dealers are becoming more careful observers of their own markets, catering more closely to its demands rather than recklessly speculating in its possible requirements. Recently some dealers who found themselves in possession of goods that were somewhat out of style, have held auctions very successfully, getting prices frequently in excess of what they would have charged at retail, thus conclusively proving that the race of Mrs. Toodles is not entirely extinct. But this is a dangerous expedient and should only be resorted to under the most favorable conditions. Another good feature of the business lies in the fact that during the past few years the number of unscrupulous and dishonest men who set up as retail dealers for the purpose of practicing their dishonesty has been greatly reduced. These men are apt to infect the trade most during its most prosperous periods, but when actual values govern prices and extreme caution characterizes every purchaser, the jewelry trade offers a less inviting field for their operations. So, too, there are fewer of those impracticable fellows, blacksmiths and tinkers, seeking to do a retail jewelry business, and it is hard to say which is the most to be congratulated on their retirement, the trade or the tinkers.

In the matter of credits there has been a decided improvement in the trade of late. Dealers are asking less and paying more promptly while manufacturers and jobbers have grown more cautious. The margin of profit in jewelry has been whittled down to such an extremely thin edge that greater discrimination has become a matter of necessity. The house that, in these times, should extend credit in the reckless manner that prevailed in more prosperous years would be sowing the seeds of its own speedy dissolution. A comparatively small loss incurred through this cause would consume the profits on many legitimate transactions. It is popularly supposed that the manufacturers and jobbers are the only ones in the trade affected by the credit system, but the fact is that the retail dealers are obliged to sell on credit quite as generally. Especially is this true in small places, the business of which is dependent upon its agricultural surroundings or local industrial pursuits. In such places money is a scarce commodity generally, circulating freely only on such periodical occasions as the farmers market their crops or the factory hands get their pay. In the intervals all business is done on credit, and if anything occurs to prevent the periodical settlements all accounts have to be extended. Farmers may refuse to sell their crops at prevailing prices, and mill owners may not be able to realize on their products so as to enable them to pay their hands, or other contingencies may arise which compel the retail dealers to keep their open accounts "open" considerably longer than they had anticipated. Meanwhile their paper is maturing in the bank and must be met. The dealer sends his bill to the farmer who says "I can't pay it now," and that ends the matter; the dealer must wait. But if he goes to the bank when his paper is due and says "I can't pay now," that means commercial dishonor and loss of credit. The horny-handed Granger may put off his bills without discredit, and if a creditor pushes him he goes to the rural legislature for protection. It is reported that a member of a territorial legislature reported a bill for the protection of debtors to the effect that if any man paid out money when he hadn't it he might be required to show where he got it! This was something like the Irish statesman in the New York legislature who wanted to bring down the premiums in life insurance by passing a law compelling them to reduce the rate of mortality! In many ways the retail dealer is loaded with cares and responsibilities that are not fully appreciated. He has the trials and tribulations of a merchant, of a salesman, and of a workman, to say nothing of those domestic trials that are the natural result of a married life and which no man can hope to escape. He represents the only class in the trade that comes in immediate contact with the

consumers of the products of the trade. His customers know little regarding the goods they want, and are as diverse in taste and opinion as they are in personal appearance. They want something, and, not knowing what they want, require the impossible. It rests with the dealer to so manipulate them as to induce them to buy what he has rather than to starve their souls in longing for that which is not. He has to educate them to an appreciation of what he has before he can sell it to them, and then, in many cases, will work as hard to get his pay as he did to sell his goods. Every position in life, but especially in the jewelry trade, has its trials, and it is well to bear this in mind when dealing with one another. But, as we have noted, there is a gradual improvement going on in the trade in all its branches, and more conclusive evidence of this fact could scarcely be brought forward than its freedom from panic during the recent crash among the Wall street gamblers.

---

### Unwise Competition.

THERE IS a great amount of competition going on in the jewelry trade that is unwise, injudicious and demoralizing. No branch of the trade is free from it. It begins with the manufacturers, permeates the jobbers and afflicts the retail dealers in every city or town where two or more of them solicit the patronage of their neighbors. This is human nature in one of its unaccountable phases. Man is an aggressive animal, a sort of bird of prey, and, deprived of civilized surroundings, would be as dangerous a beast as the tiger or the hyena, devouring everything that came in his way and gorging himself on the carcasses of his slain enemies. Civilization has done something to improve the race, but there are still many evidences left of its animal instincts which go far to sustain the Darwinian theory. Among these evidences is the innate desire most men seem to possess to crush out and destroy all who come in conflict with them in their business pursuits. Burton, the great comedian, used to say, "Man *must* live—and he *will* drink;" but this necessity is not recognized generally in the case of one man who is an active business competitor of another. The old song says:

"There wanst wus two cats in Kilkenny;  
Aich thought there wus wan cat to many;  
So they gouged and they fit,  
And they scratched and they bit.  
'Til instid of two cats there wan't any."

This Kilkenny cat spirit animates too many persons in the jewelry trade to insure that degree of harmony that should prevail. Every man has a right to live by honest industry, and we do not know that any one man has a special dispensation that entitles him to monopolize the jewelry business in any branch or in any locality. Yet there is a feeling of jealousy among dealers that would, if that were possible, shut out all competition with their particular business. There is much wisdom in the old saying that "competition is the life of trade," and if competition were rightly used and rightly appreciated, it would be found to operate as a stimulus and incentive to redoubled exertion to extend business, whereby the new development of trade would be an advantage to all engaged in it. We have found this to be true in our own experience. THE CIRCULAR has competitors, as was to be expected from the great success it has attained, but this competition has never cost us a dollar or a moment's uneasiness; on the contrary, it has stimulated us to make a better paper, to renewed exertion to cover the field of our labor, and the result has been that our business has increased. We recognize the right of anyone to compete with us; we have no monopoly of the printing business; we never have and never will say one word derogatory to any competitor who works in an honorable manner; if we cannot make as good a paper or supply the wants of the trade as well as he does, we deserve to go to the wall and he to take our place. Competition is calculated to sharpen one's wits, to arouse latent energy and to develop new expedients; if conducted in an

honorable, manful manner, it is more apt to do good than injury. So long as man is doomed to live by the sweat of his brow, each one must, on arriving at the proper age, select some field of industry in which to do his sweating. Necessarily he must become a new competitor to some one; we have all been placed in the position at some time of encroaching upon preserves that some one else regarded as especially his own. Thus far, however, it has been found that there was room enough for all, and doubtless this will be the case till that time arrives, ten millions of years hence, when this earth will be too cold for human habitation, and when the desire to monopolize the jewelry trade will not be so strong as it now is.

It is when competition resorts to low, disreputable, underhand, tricky means to sustain itself that it becomes objectionable to all honorable men. When detraction, misrepresentation, defamation, falsehood and slander play conspicuous parts in business competition the public becomes disgusted, and the time has arrived when the criminal laws should be enforced. But some men seem to be so constituted that they are not happy unless engaged in business of this kind, and who apparently think that the only way to build themselves up is to tear somebody else down, a style of competition some of our competitors have undertaken at different times and failed in. There is no good reason why men engaged in the same line of business should always assume an attitude of hostility towards each other; "they *must* live—and they *will* drink," and to this end it is necessary that they should have some occupation. If dealers would simply accord to others the same rights they claim for themselves, admitting that even a competitor may be an honorable man, we should hear less complaint regarding competition. Outside busybodies often contribute greatly towards fostering ill-feeling between dealers by going from one to another, and, by misrepresentation, seek to induce them to cut prices and underbid for custom. Tale bearing and misrepresentation play important parts in stirring up jealousy and ill-feeling, leading to retaliation and the establishment of a deadly feud between neighbors who should be friends. Travelers are sometimes found who cater to jealousies of this kind, repeating to one dealer derogatory remarks he has heard made in the store of another, with the hope of gaining the friendship and trade of the former. It may be taken for granted that the traveler who is a tale-bearer in one store will maintain his reputation in that line in the next one he comes to, and that, consequently, he is as unsafe to have anything to do with as he is unworthy. We presume the jewelry trade is no more open to censure on the ground of unwise competition than any other branch of industry, for human nature is the same everywhere, but it certainly prevails to a greater extent than it should in all phases of the business. As we have said before, we believe honorable competition begets enterprise, and is good for trade; but competition that employs dishonorable means to accomplish its ends will inevitably, sooner or later, recoil upon the head of him who resorts to it. The public is keen scented and will soon nose out and avoid the liar and the cheat. Honorable men frequently give way to jealousy of a competitor and do unwise things in consequence; the respectable portion of every community will grieve to see its business men engaged in unseemly controversies, but if both persist in calling each other bad names, the public will in the end believe both to be right in their estimate of each other. We have known instances where the reputations of respectable dealers have been seriously injured and their influence in their community wholly destroyed by an undignified competition relentlessly carried on in the columns of a local paper and by means of circulars. Mud slinging is an unfortunate pastime to engage in, for some of the disagreeable substance is sure to stick to the object at which it is aimed as well as to the hands of him who throws it.

At this time, when outside competition is seriously cutting into the trade of regular dealers, it is no time for carrying on fights within the trade by which its reputation with the public may suffer. On the contrary, dealers should combine for mutual protection. By this we do not mean that they should affiliate with those State associa-

tions that have so conspicuously shown their incompetency to deal with important trade matters, but they should have a good understanding with each other to secure the best interests of their business in their particular localities. This can be done by cultivating each other's society in a social way; many animosities have been wiped out over a good dinner, and much envy, hatred and malice has been carried away in the smoke of a good cigar. Where there are dealers enough in a city or a county they might form a social club, come together once a month, discuss the condition of trade over a good dinner and ventilate their grievances. In this way they would soon bury all jealousies and all bitterness, and find themselves naturally and without effort co-operating to advance their mutual interests, and to lend additional dignity to their calling. If they would be respected by the community in which they live they must learn to respect themselves and to fulfil their obligations as good citizens. This they will never do while bickering and quarreling among themselves. Let the lion and the lamb lie down together, and it is not necessary for the comfort of either that the lamb should be inside the lion. Much that is disagreeable in the trade arises from unwise and injudicious competition, that might be avoided by the cultivation of closer social and business relations between competitors.

---

### The Curse of Speculation.

WHEN IN recent numbers of THE CIRCULAR we affirmed that over speculation was a curse to legitimate business, we did not anticipate that so forcible an illustration of the truth of our remarks would be so soon given. But the recent disgraceful and criminal failures in Wall street were a striking fulfillment of our predictions that nothing but disaster could be expected from such gigantic gambling and swindling operations as were being carried on there. That journalist is recreant to his trust who minces words when describing such brazen swindles as led to the collapse of the various so-called brokerage firms that recently failed in such a scandalous manner, to the failure of the Marine Bank, the suspension of the Metropolitan Bank and the downfall of the Newark Savings Bank. Here was a series of financial calamities—resulting in the wiping out of the private fortunes of many and the sole resources of hundreds—directly traceable to that inordinate desire to obtain sudden wealth that leads so many to engage in stock gambling operations. These transactions were no better than pocket picking, and if some of the scoundrels who engaged in them are not sent to Sing Sing for the remainder of their days, then do our criminal laws miscarry and fail to accomplish the purpose for which they were enacted. These failures and others were attended by demoralization in the stock market, and owners of stocks sold right and left at almost any price, and thus fortunes were dissipated in a few moments. Other failures followed, and for a time there was danger that another panic like that of 1873 was about to fall upon the country. But succeeding events showed that this disaster was to be limited almost exclusively to business and to values of a speculative character; legitimate business enterprises, founded on the rock of supply and demand, stood firm and scarcely felt the shock. But there was terrible slaughter in speculative stocks, the shrinkage during the three or four days of excitement aggregating hundreds of millions of dollars.

Of course, many innocent persons whose fortunes were invested in these securities were great sufferers, and these command the sympathies of all honest men; but we confess that we are unable to get up any sympathy whatever for the victims of Grant & Ward, or for those who make a business of speculating in values which they neither own nor control, which they are unable to deliver when they sell and do not want when they buy. It is such speculation in prospective prices that fixes the market value of wheat, corn, flour, cotton and other products, and of stocks and bonds representing the value of great enterprises. The sooner speculators of this class are

ruined and obliterated, and the price of values of all kinds left to be regulated by the legitimate exigencies of supply and demand, the better will it be for the country. The victims of Grant & Ward implicitly entrusted their money to this firm, whose chief financial manipulator, Ward, is now in prison, on the assurance that it was to be invested in government contracts, the firm promising to pay anywhere from 20 to 100 per cent. profit. It was intimated that General Grant was all powerful in obtaining these contracts, but it does not appear that the General knew his name was being used in this way. As a matter of fact, the firm never had a government contract or any interest in one, and the immense profits paid one victim were taken from the deposits made by another. Mr. Ward confesses this, and also that the firm was insolvent two years ago, yet continued to take money from everyone they could induce to leave it with them. Men of wealth and reputed good judgment, who would not buy a horse without a certificate of character and a warranted bill of sale, put their millions into this "blind pool" on the sole representations of an adventurer who was looked upon as the great coming financier of the age. These experienced men knew perfectly well that no legitimate investment the firm could make of their money could pay such profits as were promised, and that if such profits were derived from government contracts they knew the government must be swindled. But, nevertheless, they went into this "blind pool" blindly, satisfied to know nothing about the character of the transactions so long as the promised profits were forthcoming, content to reap the benefits of swindling operations so long as they were ignorant of the details. It was a case of "don't want to know" with many of them; they went out for wool and few regret that they came back shorn. The president of the Marine Bank, James D. Fish, was a member of the firm of Grant & Ward, and seems to have had a better knowledge of its transactions than any other member except Ward. At least he certified checks for the firm some \$700,000 in excess of their deposits, and consented to various manipulations of securities deposited by the firm as collateral that operated to the prejudice of the bank. Other firms of brokers that failed are shown to have been engaged in transactions that should make them better acquainted with Grand Jury proceedings.

All this came about through that spirit of speculation, that gambling mania, that seems to have taken such firm possession of many of our business men and especially the younger ones. The routine and drudgery of legitimate business have no attractions for them, but in the hope of acquiring vast wealth suddenly they risk their means, their happiness and their integrity in the whirlpool of speculation, seeking that *ignis fatuus* that promises something for nothing. This speculation, mis-named business, infatuates completely the victim who once tempts it, and fortunate is he who escapes with the simple loss of his money investment. The "tricks and devices" resorted to by the manipulators of the market are on a par with those of the faro dealer and the bunco steerer, the sawdust swindler or the rogues who sell brass filings for gold bricks. An inexperienced person will stand a far better chance "bucking the tiger" in a regular gambling den than in the stock exchanges of any of the large cities. Men engaged in legitimate business might better throw their capital into the ocean than to cast it into the whirlpool of speculative gambling.

It is well known that many men in business, tempted by the reports of fortunes easily made by stock speculations, are induced to put in a few hundred dollars as "a flyer" and to tempt fortune in this manner. No man with a dollar of indebtedness has a moral right to do this. To withdraw his capital from his legitimate business and risk it in speculation is to deceive if not defraud his creditors. He never can tell how far he may be drawn in; if he loses he is tempted to try again in order to recover his loss; if he wins the temptation is even stronger to risk more where such large returns come so easily. But where one man has made a fortune in stock gambling thousands have been made bankrupt. Even the shrewdest operators in the stock market inevitably come to grief

ultimately. The list of failures in the recent crash includes the names of many veterans in the field of speculation who were supposed to be millionaires, but who could not, when they had enough, forego the excitement incident to stock gambling, and are now bankrupt. Of this class were Keene, Ward, Fish, Fiske & Hatch, Hatch & Foote, Bogardus and others. The spell was upon them and they could not shake it off in time to escape the inevitable. If such men cannot escape disaster and bankruptcy how can the ordinary business man, with limited capital and many other cares and responsibilities, hope to succeed? We reiterate what we said before the crash, the only safe and honorable course for a business man to pursue is to avoid speculation as he would the leprosy or a lunatic asylum. Take care of your business and your business will take care of you.

## Practical Treatise on the Adjustment of a Four-Jewel Cylinder Watch.

[First-Prize Essay by HERMANN HORMANN.]

*Continued from page 153.*

228. After all the defects of the watch have been corrected, the proper action of its single parts inspected and found satisfactory, the latter are to be cleaned. The best method for doing this is by means of a brush, warm water and soap. It is rather tedious, however, and cleaning with benzine is often resorted to. When making use of this latter method, however, it is necessary to previously remove the coarse dirt with a brush and pegwood.

229. Having taken down the movement in all its parts, unscrewed the end stones and caps, they are placed into a glass about one-half full of benzine—except the screws—which are in regular order placed upon the little screw bench.

230. If the watch contained polished wheels or a polished balance, they are lightly buffed with a dry, thoroughly clean buffstick in order to heighten the luster. This light buffing, which is performed upon a cork or by free hand, must not degenerate into a regular grinding, since a polish is more sensitive than gilding; beside this, untrue surfaces are produced by such a vigorous manipulation with a rough buffstick.

The use of a sword file is decidedly to be recommended for producing a good polish on wheels.

231. When all the parts have been placed in benzine they are left in it for a few minutes, which time is profitably employed for ridding the work bench of all superfluous tools.

The cleaning is then begun; one piece after the other is taken out of the benzine, and each piece dried with a clean piece of linen cloth.

232. Best suited for drying is an old piece of half linen rag. By practice and a diligent padding with such a rag the gilding can be made so clean and bright that the use of a brush can almost entirely be dispensed with; and it is next to impossible to ruin a gilding in this manner.

233. When all the parts have been taken out of the benzine and dried, a thoroughly clean, soft and rather open brush is taken with which the parts are cleansed from the fibers still adhering to them, and to impart to them the necessary luster.

234. As customary, the plate is the first piece commenced with; it is seized with silk paper, free from fiber, and held between the fingers of the left hand, after which the brush is carefully passed over several times. When the hair of the latter show a bluish or dirty tinge it must be dipped in benzine, then drawn over chalk and brushed over a piece of stale bread or calcined bones to clean it.

235. The handsome luster peculiar to gilding disappears at once from a gilding that has been treated with a dirty brush.

When the plate or the bridge is thoroughly clean, the pivot holes and the oil sinks are cleaned with a pegwood. When these are entirely clean so that the point of the pegwood does no longer darken



the wood dust is cleaned off and the plate laid under a glass bell. In this manner one bridge after the other is taken, and the gilding, sinks and pivot holes are treated in a similar way, by holding them with paper and thus avoiding to touch the gilding with the fingers.

236. The wheels are also taken in the fingers of the left hand, between silk paper, first cleaning the gilt or polished surface with fine brush; for brushing through the teeth it is better to use a fairly stiff brush. After having also cleaned the holes of the barrel and the spaces between the pinion leaves with the point of a pegwood, the escapement parts, cylinder and scape wheel are taken in hand.

237. It is evident that great care is necessary when handling these minute parts, even if only for the sake of not losing them; it will not be difficult, however, for a skillful watchmaker to clean all these parts with a fine brush, and to make use of a pointed pegwood at the places where the hair of the brush cannot enter, for instance, the interior of the cylinder; these small parts, of course, cannot be held with the fingers, but tweezers are to be used.

238. The balance spring is seized at the stud with tweezers held in the left hand; it is next laid upon a piece of clean paper, and cleaned by repeatedly padding it with a brush. All these parts, as soon as they are cleaned, are added to those under the glass bell.

The interior of the caps are carefully cleaned with a pegwood and their outside is passed over with a soft brush. When treating the minute work it is advisable to mount each piece, the hour wheel upon a tapering pegwood, but the canon pinion and the minute wheel, say, upon a pivot drill, and then to use a medium stiff brush. It happens often that these parts are "brushed away" or jump away when brushed, which accident is prevented by securely mounting them.

240. After having also cleaned the regulator parts as well as the spring core, wall stop, center staff and dust plate in this manner the mainspring is cleaned. This should never be drawn out in its full length as it breaks very easily afterward. For this purpose take a rag or a piece of silk paper between dull tweezers and draw the spring between it to and fro several times. When the screws have finally been treated with a pretty hard brush everything is ready for mounting.

## CHAPTER XIX.

### THE MOUNTING.

241. The watch is best mounted upon a special tool—the so-called movement holder. Many practical workmen, especially those who have no sweaty hands, use to some advantage a boxwood movement ring of suitable size. A brass ring should not be used when mounting, as by the repeated pushing to and fro of the plate upon the metallic ring the gilding is frequently injured.

First, the lower cap jewel plate is screwed upon the escape bridge, and this, again, upon the plate; take the center wheel, lubricate the two pivots and shoulders slightly, screw the cap upon the center wheel bridge and this upon the plate.

242. Having satisfied yourself that the center wheel runs perfectly free and no accidental changes of end shakes have occurred, place the necessary few drops of oil at the two pivots as well as in the canon for the center staff, insert the latter with the dust plate, and press the canon pinion firmly upon it. For this purpose place the movement free upon the bench if the square projects sufficiently. In the majority of cases, however, the square must be placed upon a small anvil or flat punch that fits into the cap and has been fastened in the vise; then take a hollow brass punch that fits loosely over the canon, place it upon the toothed rim of the canon pinion and drive it with a few slight taps up to the pivot of the center pinion.

243. I have found that steel punches when placed upon the canon, by driving home the canon pinion are apt to create burr, which is only discovered when the hour wheel is being mounted. It also occurs that the center staff is very easily bent, and it is advis-

able, therefore, to place the hollow punch only upon the toothed rim of the canon pinion.

The canon pinion must in no case be fitted on tightly, but the corresponding part of the center staff is in this case to be ground down carefully until the canon fits easier upon it, and only a slight tap suffices for mounting it altogether. If the canon pinion has been filed out like a lantern and is springy, a simple pressing on is enough.

244. If much pains was taken at the time of making the minute work ready, the center wheel will not pinch in its holes. Should the center staff not run exactly true but hang to one side, it must be taken out and straightened or else it can be straightened by bending with the flat pliers, while the canon pinion and center staff run exactly true.

245. Both the third and fourth wheels are next mounted and inspected whether they have sufficient end shake and run perfectly free. The scape wheel is finally added to them. Great attention must be paid here to see whether the latter stands straight, or that it can scrape nowhere or has the necessary shake. If the bridges are right, thin and springy at the place where the wheel passes the skake can well be inspected if they are pressed down a little with the pegwood, after which it must slightly spring back. With stronger bridges, the wheel is to be seized and by raising and lowering it observe the upper pivot in its hole.

It is advisable to let the four wheels run another time and to observe them with the magnifier. Small errors that are detected thereby must be corrected with all care.

246. The cap jewel plate with the regulator is next mounted and screwed upon the scape bridge; when doing this be careful to place the same side again forward which was forward at the setting of the balance spring, and examine whether the cap jewel lies secure. The regulator must not move too easily, but at the same time it should not move so hard that it requires any expenditure of force to do it.

When this is in order, oil is applied at the upper cylinder pivot hole; then take the cylinder and spring, place the former into a well-fitting hole of a clean steel riveting tool, and press the spring together with its collet upon the cylinder stud, and push it at the notch of the former until the stud stands at the mark upon the balance, and examine whether the balance stands exactly parallel to the balance.

247. Next place some oil carefully in the sink of the lower cylinder jewel hole, place the cylinder bridge flat upon the working bench, and with a screwdriver press the stud on the balance spring firmly into the bridge.

When setting the balance spring between the curb pins, always push the regulator upon "slow," so that the balance spring in all cases comes here to lie exactly in the center of the pins, and then close the balance spring guard with the screwdriver.

248. Next mount the cylinder and screw the bridge tight, whereby the balance is kept in constant motion by turning the plate to and fro in order to avoid possible accidents by an unexpected addition of errors.

249. Then again inspect the escapement and pay strict attention that everything is still in the same order, as it was regulated at the time when the escapement was set in order.

If any subsequent defects were overlooked all previous work would be in vain. It may happen that a hair from the brush has become wedged in on some part (for instance, on the balance spring stud), which gives rise to many provoking disturbances. This method of mounting is advantageous, as on account of the still wanting barrel a thorough inspection is possible, whereby the operation of the escapement can be closely inspected, and by a pressure on the center wheel any desirable quantity of power may be applied.

250. The drop is examined by slowly driving the third wheel with a pegwood, and in this manner raising a few teeth and slowly letting them drop off. Should the teeth lift too much to the left (the plate with the bridge being toward the workman), the balance spring upon

its stud must be turned more to the right, and, in a reverse case, more to the left.

251. When the escapement is in order and the balance spring lies well so that it uncoils with uniformity and does not beat irregularly, and, finally, that the cylinder has the correct end shake, oil is applied to each single tooth of the scape wheel both at its point and lifting face.

252. When applying the oil great care must be taken not to get any on the coils of the balance spring nor on the balance.

It is, therefore, best and surest if oil is applied to the scape wheel teeth before the cylinder is mounted, or that for this purpose the latter is taken down again together with its bridge which requires very little time. Not considering at present the fact that a little oil adhering on the balance would draw it out of equipoise, and attracts dust particles—which with small ladies' watches is of some importance—but if any oil should accidentally come on the spring, its coils would glue to each other and thereby cause the watch to gain.

The spoon of the lubricator used must be small so that the drops do not become too large and are able to cling to the wheel teeth; when small, the drops will not as quickly be dragged apart, whereby the spreading of the oil on the wheel and within the cylinder is prevented.

253. Then take the barrel, moisten both the upper and lower face of the ratchet wheel with a little oil and screw the cap on. The spring is wound in with a spring winder, care being taken to have the core of the latter of the same size with that of the watch. The spring, barrel hole and the thick pivot receive a little oil, the barrel is mounted upon the latter and the spring core is screwed tight.

The oil must, in all places where there are no outer sinks, or where none can be introduced, be applied to the pivots and shoulders of the wheels before mounting them.

254. A custom much in vogue of winding a spring into a barrel with fixed ratchet without spring winder, is as follows:

By turning the spring arbor with the key, by which operation the barrel is held between silk paper, the spring is hooked at the core, the open barrel is next with the left hand held upward, the first and middle fingers are laid over it so that the spring winds in flat, while with the right hand the spring is slowly turned in from below and permitted to hook in. Oil is then applied to the spring coils as well as to the upper small pivot and the cover hole, after which the cover is sprung in.

*(To be Continued.)*

---

### Walking Canes.

THE HORRIBLE habit of Americans of putting their hands in their pockets has led to the popularity of canes in this country. The Japanese gentleman shows appreciation to the same feeling when his costume is incomplete—without his shutting fan, which he hangs at his belt, over his right shoulder or in the breast folds of his silken gown. The French or English gentleman for the same reason never attends a full dress party without his crush hat in his hand.

The fashion of carrying canes, however, among the swells and lah-de-dah lads of New York has each season its rules, which are observed with as much exquisite punctilio as those of ladies who wear a poke bonnet one year and scoop hat the next. Most of these fashions originate in Europe. A year or two ago there were two styles—the shepherd's crook, shaped like a fishhook, and the Zulu crook, a plain, curved handle. The Zulu came from Paris, the shepherd from London. These styles in canes were introduced in the spring and were preceded by the crutch. When our fathers were lads the whalebone cane was the proper thing. Now they are so scarce that they are worth to the dealer from \$3 to \$3.50. Last year the fashion was to carry a silver ball cane. Then there is a

style in carrying a cane and this varies each year. One year it was to walk with a spring gait, with bent knees and arms akimbo as far forward as possible, and the cane was held between one finger and thumb, correctly balanced so as to swing gracefully. Then came the æsthetic style. The cane was held in front of the body by the first and second fingers of both hands and was allowed to hang limp, while the elbows were still further forward and the shoulders, if possible, more round. Then there was a fashion last year of holding the ferule down. This year it is to hold it in the middle with the ferule to the front, just as Mr. Spot Dandridge does after his return from the East. That's the proper "caper."

The material is as various as can well nigh be conceived of. Many are of imported woods; some from the tropics, China and the East Indies. The celebrated Whongee canes are from China, where they are well known and celebrated for the regularity of their joints which are the points from which the leaves are given off, and the stems of a species of phyllosiachys, a gigantic grass closely allied to the bamboo. The orange and lemon are highly prized and are imported chiefly from the West Indies, and perfect specimens command enormous prices. The orange stick is known by its beautiful green bark, with fine white longitudinal markings, and the lemon by the symmetry of its proportions and both prominence and regularity of its knots. Myrtle sticks possess also a value, since their appearance is so peculiar that their owner would seldom fail to recognize them. They are imported from Algeria. The rajah stick is an importation. It is the stem of a palm and a species of calamus. It is grown in Borneo, and takes its name from the fact that the rajah will not allow any to go out of the country unless a heavy duty is paid. These canes, known as palm canes, are distinguished by an angular and more or less flat appearance. Their color is brownish, spotted, and they are quite straight with neither knob nor curl. They are the petioles of leaf stalks of the date palm. Perhaps the most celebrated of the foreign canes are the Malacca, being the stems of the calamus sceptionum, a slender climbing palm, and not growing about Malacca as the name would seem to indicate, but imported from Stak on the opposite coast of Sumatra. Other foreign canes are of ebony, rosewood, partridge, or hairwood and cactus, which, when the pith is cut out, present a most novel appearance, hollow and full of holes.

The manufacture of canes is by no means the simple process of cutting the sticks in the woods, peeling off the bark, whittling down the knots, sandpapering the rough surface, and adding a touch of varnish, a curiously carved handle or head, and tipping the end with a ferule. In the sand flats of New Jersey whole families support themselves by gathering nanneberry sticks, which they gather in the swamps, straighten with an old vise, steam over an old kettle and perhaps scrape down or whittle into size. These are packed in large bundles to New York city and sold to the cane factories. Many imported sticks, however, have to go through a process of straightening by mechanical means, which are a mystery to the uninitiated. They are buried in hot sand until they become pliable. In front of the heap of hot sand in which the sticks are plunged is a stout board from five to six feet long, fixed at an angle inclined to the workman, and having two or more notches cut in the edge. When the stick has become perfectly pliable the workman places it on one of the notches, and, bending it in the opposite direction to which it is naturally bent, straightens it. Thus, sticks apparently crooked, bent, warped and worthless are by this simple process straightened; but the most curious part of the work is observed in the formation of the crook or curl for the handles which are not naturally supplied with a hook or knob. The workman places one end of the cane firmly in a vise, and pours a continuous stream of fire from a gas pipe on the part which is to be bent. When sufficient heat has been applied, the cane is pulled slowly and gradually round until the hook is completely formed and then secured with a string. An additional application of heat serves to bake and permanently fix the curl. The under part of the handle is frequently charred by the action of the gas, and this is rubbed down with sandpaper until the requisite degree of smoothness is attained.

## The Goldsmiths' Guild of England.

THE ILLUSTRATED *London News* has recently published an article descriptive of the Guild accompanied by several illustrations. This institution is one of those relics of barbarism that has been permitted to exist long after it has outlived its usefulness. The history of the Guild, divested of all romance, appears to be that certain exclusive privileges were originally conferred upon it in consideration of certain forced loans that the old Norman and Plantagenet kings were in the habit of extorting from the jewelers. In former times these privileges were valuable, but of late years the Guild has been run in the interests of persons who are fond of public dinners and of holding sinecures.

The Goldsmiths' Company is first mentioned in the year 1180, when it appears to have been a voluntary association. It doubtless had its origin in a combination of goldsmiths for their mutual protection, and to guard the trade against fraudulent workers. In the year 1300 the existence of the company was recognized by a statute which provides for the standards of gold and silver, enacting that all articles of those metals shall be assayed by the Wardens of the Craft to whom powers of search are also given. The first of the Company's charters were granted to them by Edward III., in the first year of his reign (1327), whereby the company were allowed to elect honest, lawful and sufficient men, best skilled in the trade, to inquire of any matters of complaint, and who might, in due consideration of the craft, reform what defects they should find therein and punish offenders. It states that it had been theretofore ordained that all those who were in the goldsmiths' trade should sit in their shops in the High Street of Cheap (Cheapside), and that no silver or plate, nor vessel of gold or silver ought to be sold in the City of London except at the King's Exchange or in the said street of Cheap amongst the goldsmiths, and that publicly, to the end that the persons of the said trade might inform themselves whether the sellers came lawfully by such vessel or not; whereas of late not only the merchants and strangers brought counterfeit sterling into the realm, and also many of the trade of goldsmiths kept shops in obscure turnings and by-lanes and streets; but did buy vessels of gold and silver secretly, without inquiring whether such vessels were stolen or lawfully come by, and immediately melting them down did make them into plate and sell it to merchants traveling beyond seas, that it might be exported; and so they made false work of gold and silver which they sold to those who had no skill in such things.

By two subsequent charters Edward III. confirmed and extended the privileges before granted, and gave license to them to purchase and hold tenements and rents for the relief of infirm members.

Richard II. (in consequence of the Goldsmiths having represented by their petition that the letters patent of Edward III. could not be put in execution from "their not naming persons capable"), by letters patent of the 16th of his reign, after reciting, amongst other things, that Edward the Third had allowed the Company of the said Craft to accept charitable donations and to purchase estates as aforesaid, and that they might retain a chaplain to celebrate mass amongst them every day for the souls of all the faithful departed, according to an ordinance in that behalf made, confirmed the liberties granted by Edward the Third, and granted and licensed "the men of the Craft that thenceforth they may be a perpetual community or society amongst themselves; and that the said Society or Company may yearly forever elect out of themselves four wardens to oversee, rule and duly govern the said Craft and community and every member of the same." Henry IV., by letters patent of his fifth year, recited and confirmed the preceding Charters of Edward III. and Richard II. Henry VI., by letters patent of his first year, also recited and confirmed the Charter of Henry IV. Edward IV. recited and confirmed the Charters of his predecessors, granted "to his beloved the then Wardens and Commonalty of the said craft." Moreover, he granted "that the said then Wardens and their successors may be a corporation or body corporate, to consist of and be called the

Wardens and Commonalty of the Mystery of Goldsmiths of the City of London." That they may be capable in law to purchase, take and hold in fee and perpetuity lands, tenements, rents and other possessions whatsoever of any persons whomsoever that shall be willing to give, devise and assign the same to them. That they may have perpetual succession and a common seal. That by the name of "The Wardens and Commonalty of the Mystery of Goldsmiths of the City of London" they may implead and be impleaded. That they may make good and reasonable by-laws and ordinances as often as they shall judge expedient for the better regulating the said Mystery. That they shall retain their right of trade search, and shall have the regulating of the trade of goldsmithery in all parts of the kingdom, with power to correct and punish offenders in London and elsewhere.

Henry VII., by letters patent of the twentieth year of his reign, confirmed the whole of the preceding charters, and on account of the Company being opposed in their trade search and assay, granted by Edward IV., gave them the additional power to imprison or fine defaulters in the trade at their discretion; to seize and break unlawful work; to compel the trade, within three miles of the city, to bring their work to the Company's Common Hall to be assayed and stamped; and gave them power forever, when it was not standard, to utterly condemn the same without rendering account to the Crown.

The whole of the liberties and franchises granted to the Company by the preceding charters are set forth and confirmed by insepable charters of 1st of Henry VIII., 1st of Edward VI., 1st of Mary, 3d of Elizabeth, 2d of James I., and 18th of Charles II.

The Company also received a Charter from James II., dated May 4, in the first year of his reign, whereby, amongst other things, that monarch reserved to the Crown a right of control over the appointment of the wardens and clerk. This statute was made void by the Act of Parliament 2d William and Mary, cap. 8.

The following patent also relates in part to their property—viz., 4th of Edward VI. The King to Augustine Hynde and others; grant of the rents and annual payments charged on property for superstitious uses, which property had become forfeited to the Crown by operation of the statute of the 1st Edward VI. The grantees were trustees for several of the City Corporations. The grant was made in consideration of £18,744 11s. 2d. paid to the King. The patent comprises houses and lands of the Goldsmiths' Company of great value given by twenty-four separate benefactors.

A private Act of Parliament was also passed in the fourth year of the reign of James I., by which all the houses and lands so charged with payments for superstitious uses were granted and confirmed to the several companies; and, further, James I., by letters patent, in the seventeenth year of his reign (July 24, 1619), confirmed to the Company the possession of a large quantity of property, comprising 379 houses and tenements in the City of London.

In addition to the foregoing charters, numerous Acts of Parliament regulate the proceedings of the Company in matters connected with the manufacture and sale of wares of gold and silver.

As before stated, it appears that the Company was at first a voluntary association, and had for its chief objects the protection of the mystery or craft of goldsmiths; but it was evidently also formed for religious and social purposes, and for the relief of the poor members—for in the very earliest records we find sums paid for superstitious purposes, such as the keeping of the obits of deceased members, the providing wax lights which were used in celebrating the obit, and were held by the almsfolks during such celebration; for ringing bells on St. Dunstan's Day, and for the vestures of the Chaplain whose duty it was to say masses for the souls of deceased members. St. Dunstan was the patron saint of the mystery, and the Company had a chapel of St. Dunstan in St. Paul's Cathedral. We also find in the early records entries of payments for feasts (the sum expended in 1367 on St. Dunstan's feast was £21 8s. 9d.), and of payments made to the poor.

The powers exercised by this voluntary association over the craft were subsequently confirmed to them by their charters. The Wardens fined workmen for making wares worse than standard; entered their shops and searched for and seized false wares; settled disputes between masters and apprentices, and frequently punished rebellious apprentices by flogging; levied heavy fines upon members for slander and disobedience of the Wardens, and for reviling members of the livery; and generally exercised a very powerful and absolute control, not only over the members of the fellowship, but also over all other persons exercising the goldsmiths' trade.

For the purpose of the assay they had an assay office in the early part of the fourteenth century. The statute of 28, Edward I., enacts that no vessel of gold or silver shall depart out of the hands of the workmen until it is assayed by the Wardens of the craft and stamped with the leopard's head—the leopard being at that time part of the royal arms of England.

The Company and its members, even at this early period, appear to have acted as bankers and pawnbrokers. They received pledges not only of plate but of other articles, such as cloth of gold and pieces of napery.

The London goldsmiths were divided into two classes, natives and foreigners. They inhabited chiefly Cheapside, Old Change, Lombard street, Foster Lane, St. Martin's-le-Grand, Silver street, Goldsmiths' street, Wood street and the lanes about Goldsmiths' Hall. Cheapside was their principal place of residence. The part of it on the south side extending from Bread street to the Cross was called "The Goldsmiths' Row." The shops here were occupied by goldsmiths, and here the Company possess many houses at the present time. The exchange for the King's coin was close by, in what is now called Old Change. The native and foreign goldsmiths appear to have been divided into classes and to have enjoyed different privileges. First, there were the members of the Company who were chiefly, but not exclusively, Englishmen; their shops were subject to the control of the Company; they had the advantages conferred by the Company on its members, and they made certain payments for the support of the fellowship.

The second division comprised the non-freemen who were called "Allowes," that is to say, allowed or licensed. These were the "Allowes Englis," "Allowes Alicant," "Alicant Strangers," "Dutchmen," "Men of the Fraternity of St. Loys," etc. All these paid tribute to the Company and were also subject to their control. The quarterage paid by the members and the tribute so paid by the "Allowes," constituted the Company's original income. We find frequent mention of efforts made by the English goldsmiths to prevent foreign goldsmiths from settling in London but they did not succeed. The wise men of the craft probably knew that the best artists were foreigners, and were willing to profit by observation of their works and mode of working. In 1445, thirty-four persons, who were strangers, were sworn and paid 2s. a head. In 1447, Carlos Spaen paid £8 6s. 8d. to the Alms of St. Dunstan to be admitted a freeman; and in 1511 John de Loren paid £20 for the same object.

The Wardens also frequently obliged foreigners applying for the freedom to produce testimonials from the authorities of the towns abroad where they had resided.

The government of the trade under the Company's charters continued up to the reign of Charles the Second. But some time before this period, and in the interval between it and the passing of the Act of the 12 George II., cap. 26, the powers which had been granted to the Company began to be questioned; and the Company experienced difficulty in putting them into force. In 1738 they considered it expedient to obtain an Act of Parliament. The 12 George II., cap. 26, passed in 1739, was prepared by the officers of the Company, brought into Parliament by them with the assent of the Government of the time, and all the cost of soliciting it and getting it passed was paid for by the Company although it is a public Act.

This act recites the 28 Edward I., cap. 20; the 2 Henry VI., cap.

14; the 18 Elizabeth, cap. 15; the 12 William III., cap. 4. It also recites that "The Wardens and Commonalty of the Mystery of Goldsmiths of the City of London are and have been a guild or corporation time out of mind, with divers privileges confirmed and enlarged by several charters from his Majesty's royal predecessors, Kings and Queens of this realm (amongst other things), for the searching, assaying, supervising, marking and regulating wrought plate, in order to ascertain the standard thereof for the good and safety of the public." It also recites the charter of 18 Charles II., and that "the standards of the plate of this kingdom are both for the honor and riches of the realm, and so highly concern his Majesty's subjects that the same ought to be most carefully observed and all deceits therein to be prevented as much as possible; but, notwithstanding the aforesaid several Acts of Parliament and charters, great frauds are daily committed in the manufacturing of gold and silver wares for want of sufficient power effectually to prevent the same."

The enactments which follow, together with the enactments contained in the Act of 7 and 8 Victoria, cap. 22, comprise all the principal laws which regulate the goldsmiths' trade, and under which the Company act at the present day.

Under this Act the Assay Office is regulated. The Company are empowered thereby to make charges for the assaying and marking plate sufficient only to defray the expenses of the office, and are prohibited from making any profit thereby or deriving any pecuniary advantage therefrom.

At a very early period there were members of the governing body of the Company, both Wardens and Assistants, who were not of the craft.

Conspicuous citizens who are freemen, and many great merchants, bankers and even military men and lawyers filled those offices. The sons of a freeman were entitled to the freedom, and became free by patrimony whether they were craftsmen or not. Hence the children of goldsmiths who had acquired wealth and importance and who did not follow the business of their fathers, furnished a large and important class of freemen from whom members of the governing body were chosen. The leading bankers, themselves the descendants in trade of the old goldsmiths—from the time of the Stuarts to the present time have been some of the most conspicuous members of the body. Amongst them we find the names of Sir Martin Bowes, who was Master of the Mint in the reign of Elizabeth, Sir Hugh Myddleton, the enterprising founder of the New River, Sir Francis Child, of Temple Bar, Sir Charles Duncombe, Sir James Pemberton, Sir Robert Vyner; and, in the present century, Robert Williams and Thomas Hallifax, Henry Sykes Thornton, William Banbury, John Charles Salt, Herbert Barnard, William Newmarch, William Cunliffe Brooks, Robert Ruthven Pym, Arthur B. Twining, Charles Hoare and Robert Williams, jun.

It remains to mention the connection of the Company with the coinage of the realm in what is called the Trial of the Pyx, an office which has been performed by the Company ever since the reign of Edward I. Its object is to ascertain that the metals of which the moneys of gold and silver coined by the Mint are composed is standard, and that the coins themselves are of the prescribed weight.

This duty was performed in ancient times at uncertain intervals, and usually had for its immediate object the giving an acquittance to the Mint Master, who was bound to the Crown by indentures to coin money of the prescribed fineness and weight. But the Coinage Act of 1870 provides for and establishes an annual trial, and since that date the Pyx has been brought to the Goldsmiths' Hall and tried annually. In former times a jury of competent freemen summoned by the Wardens, was charged by the Lord Chancellor who subsequently received their verdict. But this practice has been changed, and at the present time the jury is sworn by the Queen's Remembrancer, who—the trial having been made and the verdict of the jury reduced to writing—attends at the Hall and receives it, after which it is published in the *Gazette*. In this manner the last trial took place at the Hall in July, 1883.

It will be seen, by what has been already stated, that by charters and Acts of Parliament extensive rights or powers are vested in the Company to exercise superintendence over the manufacture and sale of wares of gold and silver. These are exercised by their assaying and stamping gold and silver plate, and by the prosecution of offenders against the laws which regulate the standards of plate and the marking thereof. These powers extend to every part of England; that is to say: A dealer in any part of England who sells an article of gold or silver which is required to be assayed and marked, and which article is below the required standard, or has not been marked as required may be proceeded against for penalties; and any person in any part of England who forges the marks of the Company or utters wares bearing counterfeit marks, with a guilty knowledge, may be prosecuted for felony; but in the case of the forgery of the particular marks of those provincial companies which have the power of assaying and marking plate, the Goldsmiths' Company of London do not interfere.

We have now briefly to describe the constitution and present condition of the Goldsmiths' Company and its splendid establishment. The Governing Body of the Company is composed of a Prime Warden, three Wardens and a Court of twenty-one Assistants. The only persons mentioned in the Charters as forming the Governing Body are the four Wardens; but the Assistants are mentioned in the Records as early as the fourteenth century by the name of "the Good Folks of the Mystery;" and at the commencement of the sixteenth century we find them mentioned by their present name. The total income of the Goldsmiths' Company is now estimated at £92,700 a year, including the different trust properties in its management. It supports the Almshouses and Church of St. Dunstan at East Acton; schools at Cromer and at Stockport, exhibitions at the Universities to the amount of £3,000 a year, subscriptions to various charities, grants to promote technical education, and prizes for the best designs in goldsmiths' and silversmiths' work, annuities to retired officers and donations for sundry benevolent objects; but there is no public account of the larger part of its expenditure. The amount paid in salaries is £4,292; the expense of holding Courts and Committees are stated at £1,576; the cost of dinners and other entertainments, £4,300, besides £1,960 for wine. The magnificent building called Goldsmiths' Hall, situated in Foster Lane behind the General Post Office, St. Martin's-le-Grand, was re-erected in the Renaissance style of architecture from the designs of Mr. Hardwick in 1835. In the basement of this palatial edifice are the offices for the business of the Goldsmiths' Company. The building and the site which it occupies as freehold property have been rated at the annual value of £5,500, but must be worth nearly £8,000 a year

### Problems in the Detached Lever Escapement.

BY DETENT.

WE CONSIDER the grinding and polishing of pallet stones of so much importance in correcting faulty escapements that we shall dwell on it to some length. In the cuts of our last number we showed the manner of grinding the pallets to the correct angle. To explain a little; it is not absolutely necessary to use a diamond lap to grind a pallet stone; fine emery will answer only it cuts slower. As, for instance, in the case considered in last number, if we wished to grind away the angle at *d* we would put the pallets in the holder shown in figs. 4 and 5 (last number), and put our emery lap into the lathe; this emery lap is simply charged with fine emery and water, and the pallet applied as shown in fig. 4 will be soon cut away; and if the emery is very fine the surface ground will be quite smooth. The angle should be ground to the correct form when the lap on which the emery has been used should be changed and the one on which rotten stone and water (precisely as for emery) is substituted. The reader may find some difficulty in

obtaining very fine and even flour of emery; this can be remedied by using the common flour of emery without any further care or preparation except to put say, half an ounce of the flour into a bottle with about two or three ounces of water and shaking the mixture well; if a splinter of wood is inserted into the fluid and applied to the lap it will convey enough of the mixture (fine emery and water) to prepare the lap for grinding. The philosophy of this is that by shaking the emery up with the water and giving it a little time to settle the coarser particles are carried to the bottom quickly, while the fine particles which are still suspended and afloat are taken by the splinter to the lap. The pallet should be washed or thoroughly rubbed with soft pith to remove any particles of emery before being applied to the rotten stone lap. If the emery acts greasy and will not mix readily with the water, add a little ammonia or borax to the water. In addition to the arrangement shown in figs. 4 and 5 (last number) we can make the part *L* so it will turn a little in *F* and produce a round front or faced pallet. But it is very doubtful if the rounding of a pallet face especially in a ratchet tooth scape wheel is of any advantage. The details of the arrangement is shown at fig. 1 in this number. It only differs from the plan shown before except that there is a joint at the foot of *L* where it attaches to *F*. The shape of *L* is also altered so as to make the joint turn opposite the pallet which is being ground as shown in fig. 1. It will be seen that there is an offset in *L* at *d*, so that *L* will rock or vibrate on the dotted line *f*; this line is supposed to pass through the center of the face of the pallet stone being ground. The manner of producing or rather

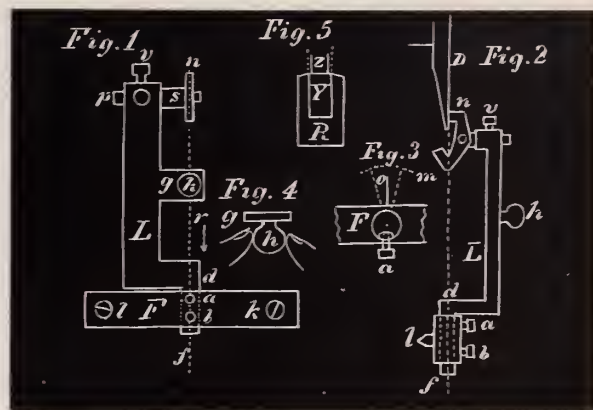

permitting the vibratory motion is by making the portion of *L* below *d* which passes into and through *F* round as shown in fig. 3, which is a view as if seen in the direction of the arrow *r*, fig. 1. This round pin or pivot on which *L* turns is secured to *F* by two screws shown at *a b*; one of these screws goes into a pit drilled into the bearing or pivot just large enough to receive the point, which, of course, holds it firm and steady, while the other screw enters a pit or recess in the pivot large enough to permit it to turn in an arc of 15 or 20 degrees, as shown at the dotted lines *m*, fig. 3, while the other set screw holds the pallet square to the front as shown at the full line *o*. Fig. 2 is a vertical section of fig. 1 on the dotted line *f*. This holder has three prominent changes from the one shown in last issue; first, the turning pin at *d*; second, the offset in *L*; and third the adjustable part of *s* (former number), so that by means of the set screw *v*, fig. 2 (present number), the pallet can be brought forward. At *g*, fig. 1, is shown an extension from *L* from which projects a knob *h*. Fig. 4 shows this part as if seen in the same direction as fig. 3. The idea is if the knob *h* is grasped with the thumb and finger and the screw points of *k l* inserted in the pits described in last issue, a rocking motion can readily be given to pallet stone *n*, fig. 2. There will be nothing needed more than shown in these cuts to grind and polish a pallet stone. A few lines above we spoke of the doubtful advantage of rounded pallet faces for the action of ratchet tooth scape wheels. Probably the best form of pallet stone for ratchet tooth scape wheels is a flat surface as shown in fig. 5, where *Y* represents the pallet stone, *R* the pallet arm and *L* the tooth. The face of the pallet stone should be wide enough so the tooth never leaves

the stone by any change in the condition of end shake as illustrated by the dotted lines on each side of *Z*. It is theoretically supposed that a ratchet tooth comes to a knife edge angle, and the rounding of the face of a pallet stone will in no appreciable degree abate the friction. A word or two on oiling; *a brass or gold ratchet tooth lever escapement needs no oil*. Occasionally (but it very seldom, however), we find a steel ratchet tooth scape wheel; *this* should be oiled or they will soon cut, and one will find the escapement full of fine red dust like rouge. On the other hand the club tooth lever needs the pallets oiled even if the scape wheel is brass or gold. This need of oil on the pallets of the club tooth lever escapement is one if not the only serious objection to the use of this style of lever. It is the escapement par excellence to go safely through the hands of that class of workmen who have more strength than skill. But that it will hold its rate through months of test with the ratchet tooth is not to be thought of. If finely made in connection with an isochronized hair spring, a club tooth escapement will give splendid results, and be free in a great manner from liability to injury to which a ratchet tooth escapement is subject; as, for instance, your able bodied watchmaker is putting up an English ratchet tooth lever; when he comes to putting on the canon pinion he finds it too loose to carry the hands softly; now, what does he do? Probably takes his cutting pliers and seizes the center arbor, and wrings a burr up on the center arbor, applying force enough to in many instances to bend the scape wheel teeth. And even if he does not in the first instance he puts the canon pinion on so tight that he does bend the teeth in trying to get the pinion to turn on the center arbor. Now, I am well satisfied that four out of five instances of bent teeth in ratchet teeth scape wheels come from this cause. The true way to remedy the defect of looseness in the canon pinion is to try the pinion on the arbor when the watch is apart and then remedy the difficulty. How to remedy it in the best way is a question which has puzzled workmen ever since the introduction of a loose pinion both as regards the canon pinion of the English style or the hollow center pinion with set square of the Swiss. This fault in a watch is one which is passed over too lightly by a large majority of workmen satisfying themselves with a make-shift method of some kind. I am aware it is not strictly a problem which should be considered under the title of this series of articles but as it has so important a bearing on the ratchet tooth lever escapement I shall devote space enough to this subject to describe a safe and efficient method of doing this job.

---

### The Antique Boom.

THE ANTIQUE boom has reached Europe. "Eastward the star of fraud doth wend its way," and it should be made a grave offense for any \$10,000 man who refuses to surround himself with venerable furniture once belonging to Chosroes II. or one of the Pharaohs. A continental exchange says it is universally known that antique furniture, the most recent of which is from 200 to 300 years old, while others, dating from every period in the world's history and in every imaginable state of dilapidation, is at present introduced into commerce by those who understand the business. Old clocks, old toilets, old bedsteads, even if only finished yesterday, possess a great charm for many who seek a pleasure in antique shapes and appearances. The present boom is directed toward worm-eaten furniture; the worm holes are easily produced by a few charges of small shot. Old houses, when torn down, also furnish worm-eaten wood from which are manufactured sets of furniture once used by Philipp the Second, of Spain. France manufactures old Rouen and Sèvres porcelain by the ship load; Limoge-enamel is plentifully found; the new article is laid for one month in the humid earth, and by this manipulation is made to date back from 300 to 400 years. The purchaser may please himself as to age. The celebrated pieces of the time of Henri II. (be sure you pronounce it

with a French twang—it gives you the air of a connoisseur), are manufactured during the whole year. They become antique in a short time when treated with fluoric acid. A vase, originally costing 20 shillings, can, with the judicious use of acid at a cost of 10 cents, be quickly transmogrified into an article valued at \$1,500. The Berlin potteries are busily employed in manufacturing Roman clay vessels from the time of Romulus and Remus forward, ranging through all the emperors.

And yet they are not happy.

---

### Advice to Watchmakers' Apprentices.

BY A MAN WHO HAS SPENT TWENTY YEARS AT THE BENCH.

THERE ARE many little tricks of the trade—some workmen call them *rackets*, others *dodges*—it makes small odds what name is used so the workman can avail himself of some plan to facilitate his work. I propose to give a few little hirts of this kind for the benefit of beginners; many are common to the trade, others may be comparatively new. In the job shop hard solder jobs require by far the most skill and experience. It is well known that silver articles are soldered with silver solder, a hard solder composed of silver alloyed with yellow brass. This is known in the trade as a silver solder; and another thing is equally as well known to the workmen, which is, it is not easy to get a silver solder which melts easily and flows into the cracks and joints readily. Or, in the language of one of my boys, "*squats and hunts its hole*." This phrase, although not quite so elegant as it might be, conveys the idea of the requisites of a good silver solder; for a little pellet of good silver seems to hold its form perfectly up to a certain degree of heat, after which it seems to become fluid instantly, flowing into every crevice so quickly the eye cannot follow the flow. On the other hand poor solder will appear to wither and blacken in spite of the borax, or creep up into a little globule and defy all kind of coaxing to flow. Most of our books on jewelers' work give the formula for making solders of fine silver, copper and zinc (*spelter*). Now, we all know that a strictly pure article and an alloyed or adulterated one are quite different; consequently, if we take the commercial articles named we are not always certain of the results. Any person who is skeptical on this let him try to get up an alloy of 18-k. with all copper, and he will find it extremely difficult to get the copper sufficiently pure so the alloy will work well. Consequently, in making hard solder the results are not always the same, although apparently the same materials and proportions are used. For making silver solder (ordinary hard solder), I have had more satisfactory results by using old English watch plates in the proportion of  $\frac{1}{2}$  brass to coin silver (900 fine) than any other mixture. I am well aware there should be no reason why yellow brass should not be about the same thing the world over, but I know (or believe) that I am likelier to find the peculiar brass I want for silver solder in old English watch plates than in any other. In making gold solders if you take some of the gold you are working and add about 2-k. of the silver solder just mentioned it will be found to work and color well. As finger rings constitute a large portion of our hard solder jobs, I will commence with the commoner kinds of jobs in this way. Making a ring larger, *i. e.*, putting in a piece is one of the commonest calls we have, and any way by which we can expedite the work is the idea we want. Of course, we must have gold of the same color, and if our task is a plain gold ring we can generally hit it the first time; but if it should be a ring of some fancy pattern we could make a little button of alloy to suit and flatten it, as has been described, when we can cut a piece to fit. Binding the piece in with wire so it will not slip is an operation in which beginners usually have trouble. About the best method of holding the piece in is to use a piece of old watch mainspring bent into a hoop as shown at *B B*, fig. 1. The piece of mainspring should have a hole in each end as shown at *C\**, which is

a view of  $B^*$  as seen looking in the direction of the arrow  $c$ . At  $HA$ , fig. 1, is shown the ring to be enlarged with the piece  $a$  inserted and the whole surrounded by the band  $B$ . At  $d$  is inserted in the holes in the ends of the mainspring band a piece of binding wire, which by twisting as shown the mainspring band can be made to firmly compress the pieces together. An assortment of such bands will soon accumulate and they can be used over and over for several times. The reader will, of course, know that the piece  $a$  should be a trifle thicker than the ring so as to finish up to the same thickness. At fig. 2 is given a better method of joining the piece shown at  $b$  and the ring. In this case the ends of ring is filed into a notch as shown and the end of the piece is filed to fit. This method also admits of the use of the clamp shown in fig. 1. The advantages of this method are the piece is held from turning or slipping, and it also makes a much stronger joint and admits of more hammering on the ring stake to bring the parts into shape. The ring can be coated with a coat of yellow ochre almost up to the joints to preserve the color. Here, again, is an example of where the same thing is not always alike (as one might say). It is not all samples of yellow which are desirable, as some will almost perfectly protect the color and polish while another specimen of yellow ochre would be almost worthless. All that is needed to do is to rub up the yellow ochre with water and a very little borax into a moderately thick paint and paint over the parts to be protected. If the ring to be spliced is a stone ring, the upper part containing the stone can be protected by burying in wet sand as shown in fig. 3. In this cut  $F$  represents

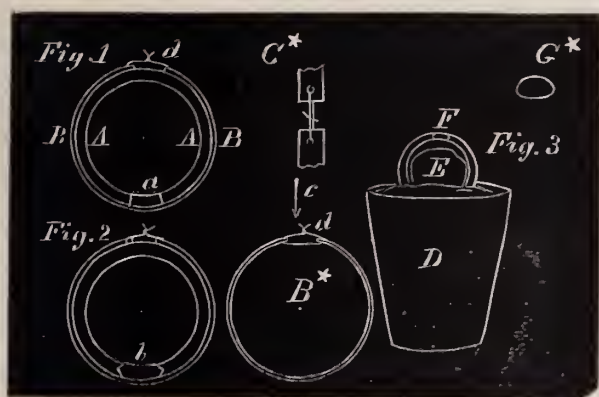

the ring and  $D$  a dish to hold the wet sand; in this case we have shown a small crucible which is quite as convenient as anything. Inside the ring shown at  $E$  can be put a small piece of charcoal to concentrate the heat at the joint. Usually the sand will have to be moistened several times as the work progresses to protect the stone; this can be done by having a small bottle containing water, the bottle being corked with a cork having a quill in it, so that by shaking the bottle (bottom up) small jets of water can be thrown on the sand round about the ring. Notching the ring or the piece inserted is of great advantage in this kind of job, as it holds the piece from turning or in any other way getting out of place. If you notch one end of the piece inserted it is quite sufficient, as after you have soldered the notched joint the other end can be jointed and united in the usual way as the first joint holds the parts in place; but as said above, the notched joint is much the strongest and consequently the best. For holding rings shaped in cross section as shown at  $G^*$ , the mainspring band is invaluable. For boiling out in pickle (sulphuric acid, 1 part; water, 4 parts), a copper dish formed of heavy sheet copper beat into a cup by hammering on a convex piece of iron. The copper cup should be about No. 14 or 16 made from a disc quite 3 inches across. A piece of round bar iron one inch in diameter filed to a convex surface on the end answers well for a stake; the copper should be repeatedly annealed until a cup is formed an inch deep which will answer for most articles. The pickle should be kept in a glass or earthen dish and put into the copper cup when used. A copper handle should be riveted on to the cup with a copper rivet. Sometimes in hard soldering a joint on gold watch case, the case will assume a greenish hue owing to the silver in the alloy which is

difficult to remove even by buffing. This can be overcome by putting for a few seconds into a mixture of sulphuric acid and saltpeter (no water) heated up to about  $200^{\circ}$  F. Perhaps I should have said above that the notch at  $b$ , fig. 2, is filed with an ordinary square file turned to an angle. The holding band formed of a piece of old mainspring is shown separate at  $B^*$ . Such an appliance may be held in small favor by the regular working jeweler but to the novice it is a big relief, and many watchmakers are compelled to do their own jewelry work.

#### Wet Coloring by the German Process.

**T**IE UP your work in small bunches with fine silver or platinum wire; then, for 3 ounces of work, take a black lead pot 6 or 7 inches high, and having previously placed your work in hot water, put into it 6 ounces of saltpeter and 3 ounces of common salt; stir them well with a wooden spoon, and when thoroughly dried fine and hot, also 5 fluid ounces of muriatic acid. When boiling up put in your bunch of work, having previously shaken the water from it, and keep it moving for 3 minutes taking care to keep it well covered all this time. At the end of this time take it out and plunge it into a vessel of clean hot water, and finally into a second vessel of the same. Then add to your color in the pot 6 fluid ounces of hot water, and when it boils up again after being thus diluted put in your work for 1 minute longer, and again rinse it as before directed when it will be found to be of a beautiful color. Too much clean hot water cannot be used for plunging the work in each time.

If the work is hollow and bulky, not quite so much as 3 ounces should be put in as it is not effectually immersed in the pot.

In wet coloring it sometimes happens that the color is rather dead, or it may happen that the "color" burns, which causes the work to look brown; this is a precipitation which may be removed by scratching at the lathe with stale beer, using a fine brass wire brush similar to the round hair brushes used for polishing.

In coloring a large stone jar should also be provided into which should be emptied your "color" when done with, because the pot should be washed out each time so as to be ready when wanted again, also the wash water used, as it contains quite a percentage of gold. All things in connection with the process should be kept clean and free from grease of any kind. Do not keep iron near this wet color in the pot as it is most injurious.

#### Balloonatics and American Watches.

**T**HE BALLOON Society of England, at its meeting yesterday, became excited over a discussion upon the watch trade of the country. There being no subject pertaining to aeronautics before the meeting to engage the debating powers of its distinguished members, Sir John Bennett, the great clock-maker, introduced the topic of chronometers. This led to a general discussion upon the watch and clock making industry. Many of the greatest experts in the clock trade of England belong to the society, and several were present, all of whom joined in the debate. Sir John Bennett and Prof. Whipple both declared that the cheap American and Swiss watches and clocks were being so successfully introduced into Great Britain that they were rapidly gaining preference among the people and ruining the English industry. Sir John admitted that the business of making time keepers in England was in a most desperate condition of decline, and he declared that unless something effective were soon done to counteract the American and Swiss competition, the "British article would be extinct in a very few years." The society resolved to petition the Government to appoint a commission to make an official inquiry into the causes of the decline of the British watch and clock manufacture and report upon the best plans to arrest the decline and restore the trade.

The above we find in the London correspondence of the daily *Times*. If the Balloonatics in question will subscribe for *THE JEWELERS' CIRCULAR* there will be no occasion for an official

inquiry to ascertain why cheap American watches are preferred in Great Britain to watches of similar grade of British manufacture. The simple fact is that American manufacturers have so perfected their machinery for making cheap watches that they turn out a better timekeeper at less cost than the British manufacturers have ever been able to produce. Attempts have been made to introduce American machinery for watch production into Europe, but foreign mechanics do not understand it, cannot be made to comprehend it; and, as the machines cannot yet make watches automatically, they have not been successful. It required Yankee skill and Yankee ingenuity to perfect the machinery, and these qualities are necessary to operate them profitably. In the matter of fine, expensive, hand-made watches, European workmen fully hold their own. Indeed, so satisfactory are the comparatively cheap watches made by machinery in this country, that our workmen have little incentive to acquire the art of making fine movements; but in the production of the lower grades they can never be excelled. An official inquiry into the matter would, no doubt, lead to the recommendation that if British manufacturers wish to compete with the cheap American movements they must secure American machinery and Yankee workmen to run it. But what have these Balloonatics got to do with watch making anyway? An anxious world is wearily waiting for them to develop some method of navigating the air with speed, comfort and a reasonable degree of safety, but they are no further advanced in the science of aerial navigation than they were a hundred years ago. Do these watchmakers, who are also Balloonatics, expect to apply the watch principle to provide motive power for their air-ships? If so they should send for our old friend, Aristarchus Plumbago, and obtain the right to use his "bicycle movement," which he warrants to be applicable to any purpose, from frying slapjacks to furnishing motive power for any purpose. Give Aristarchus a chance in the balloon business and he'll "put a girdle round the earth" in considerably less than forty minutes. We would, however, recommend to the Balloon Society that they attend to their own particular knitting and let the watch industry take care of itself. They have been incubating on the question of aerial navigation for a long time, and if they leave the nest the eggs are liable to become addled.

### The Gorham Manufacturing Company's New Building.

IN OUR issue of last month we made a brief allusion to the new building of the Gorham Manufacturing Company, at Nineteenth street and Broadway. At that time the Company was not fully settled in its new quarters; carpenters, cabinet-makers, painters, plumbers and other workmen were in the building at work, and it was impossible to obtain a realizing sense of the elegance of the interior, or even of the building itself. Now that the Company is fully settled in one of the finest structures in the country occupied by the jewelry trade, their establishment is entitled to more than a brief notice, as it affords another illustration of the energy and enterprise that characterize this company.

The building, which is of brick with terra-cotta trimmings, is built in the old Dutch style of architecture. It stands very high and has a frontage of 55 feet on Broadway and 120 feet on Nineteenth Street. Seen from Union Square, with its oddly-shaped tower of clay, casting long shadows on the buildings beneath, the scene is highly suggestive of the streets of old Antwerp. There are eight stories in the building, three of which are devoted to the business of the Gorham Company alone. The basement has been utilized principally as a stock room. Here duplicates of every piece of silver and plate shown in the two immense warerooms overhead are constantly kept on hand. Departments for polishing, charging, packing and shipping goods are also located in the basement.

The floor above is devoted exclusively to the exposition of goods sold at retail. The principal entrance is from Broadway. It con-

sists of a most commodious and unusually high vestibule, with an oddly designed floor of tiling, flanked on either side by an immense show window. The doors, which consist of highly polished solid mahogany and heavy beveled French plate glass, are especially noticeable for their design. This consists of a large center plate set around with small squares. On entering, three long lines of show-cases meet the eye. On the right, there extend the whole length of the building the wall cases. These sparkle with their valuable contents of crystal and silverware. Only Gorham plate is here exposed. Two rows of cases run the entire length of the room down its center; at each end a rounded case abuts these longitudinally arranged, and the effect is that of two immense crystal horse-shoes, placed foot to foot. On the left, six alcove cases, standing eight feet high, are arranged for the display of sterling silver. The wood-work about the room and of the appointments is all alike, and is of solid, highly polished mahogany. Nine immense iron pillars finished in bronze lend additional attraction and security to the room. Around these pillars there have been arranged numerous incandescent burners of oddly designed patterns and their rays glint among the highly polished contents of the cases. The show windows are not deep, but are uniform in their fronts with the other windows of the building and are highly ornate at the back in railings of twisted brass and bronze.

On the second floor are situated the wholesale show rooms and offices. Large upright standard cases extend the full length of the room down the center, while alcove cases, between which are arranged show tables, desks and chairs, line the sides and front. An elevator and broad staircase of iron and marble render the ascent more easy. Altogether there is not a more elegantly appointed house in the city.

### Lathes and Lathe Work.

BY THE MODEL WATCHMAKER.

IN FITTING up such a lathe as was partially described in our last article, it is of vital importance to make all the parts comparatively heavy to ensure stability and steadiness. But it is not intended to touch any of these parts to finish except for accuracy; but in this sense it is hard to discriminate, for accuracy is held by different kinds of mechanics to admit of great latitude; as, for instance, a country blacksmith would call measuring to a quarter of an inch close work. A carpenter would insist  $\frac{1}{32}$  of an inch was close work. A fair machinist would demand working to  $\frac{1}{100}$  of an inch; while some of our watch factory men would insist on  $\frac{1}{1000}$  of an inch and talk about  $\frac{1}{10000}$ . Accuracy to even the last mentioned figures is attainable even in such a lathe as we are describing; but there is another question arises; suppose we had such a lathe how many men are capable of working it so as to produce articles of such a degree of truth? To illustrate; if our ways as described in our last communication were finished in the best manner on a parallel grinder, it would be possible to produce very accurate work in skillful hands. But let us consider how inaccuracies in the lathe are going to affect the work produced. The truth of the ways would not materially affect the ability of the lathe to turn a piece round, but it would be important as regards turning cylindrical; as, for instance, we wished to turn a piece of steel 5 inches long and  $\frac{1}{2}$  an inch in diameter from end to end. Now if our ways are perfectly straight and our centers perfectly parallel to the ways, theoretically, our lathe must turn a perfect cylinder; but we find it will not do it; as a rule our piece will be found largest in the middle owing to the spring of the piece in the lathe by the action of the turning tool. To remedy this it is customary to shape the tool so as to cut a continuous chip. The shaping of the tool is intended to have the same effect as a graver has when pushed along and has no tendency to enter deeper into the plate or jump out. But owing to several contingencies this arrangement does not perfectly effect the desired



object. Among the contingencies are inequality in the density and hardness of the metal we are turning. At fig. 1 is shown a transverse section of the supposed piece we have in hand, *A* representing the piece to be turned, *B* the turning tool. Now, in considering the question of the effect of forces as factors involved in this problem, we will assume the cutting tool *B* encounters a hard spot at *d*, fig. 1. It is also assumed the tool is so shaped at the point as to only hold

hold that a continuous spiral equal in size of coil and pitch (by pitch, I mean the spiral appearing even like the threads of a well cut screw), being evidences of a tool cutting to the best possible advantage. Now, this is not true in theory as will be seen if we investigate the matter. We will first suppose our tool is applied as at *B*, fig. 3; here *A* represents a cylinder (like our spindle) in a lathe, the tool is pressed forward in the direction of the arrow, and the chip is curled in a circle as shown in fig. 1 without any tendency to form a spiral. Now, if the turning tool is given a lateral motion (feed) in the direction of the arrow *r*, the chip will still be curved but assume the spiral form. But if the tool was obliqued around so as to present the cutting angle as in the dotted line *n*, fig. 2, the chip would still be curved but not spiraled. The depth of the cut proportionate to the rate of advance in the feed are also factors to be considered, for by these two influences alone can the chip be made to spiral either to the right or left, that is if the tool is set oblique as at line *k*. These ideas and facts are brought to the reader's notice for the purpose of fixing his attention and inducing him to think and investigate for himself. Rapidity and correctness of execution can only come after a knowledge of the subject is in a degree mastered. A full firm chip, with a strong heavy lathe, cut by a tool set for its work by knowing and skillful hands, will produce superior work and in twice the quantity to one manipulated, no matter how carefully, by a person who never considered exactly how his machine done its work. The writer considers it essential for a man before he commences to build a machine to know perfectly for what purpose he is building it and the manner in which it is to operate.

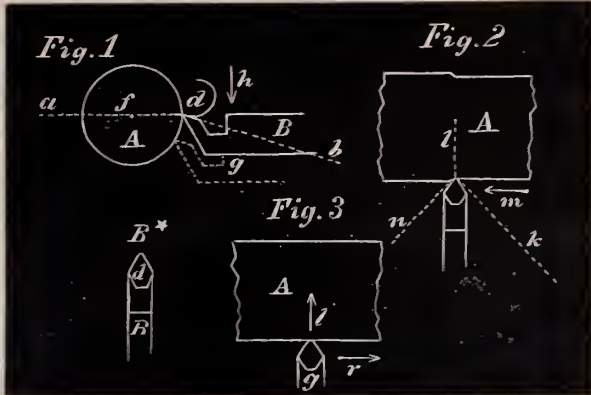

its position, that is, neither eat in or has a tendency to throw out as illustrated by the graver cutting above mentioned. Now, when the tool *B* encounters the hard spot at *d*, the first effect is to rise the center *f*, fig. 1, by springing the arbor we are turning. Let us consider what effect this will have on the tendency of the tool *B*. If the spot should be intensely hard so as to preclude cutting it completely, of course the spindle *A* will spring away from the tool. But in all ordinary lathe work the spot will only be a little harder—offering a trifle more resistance—the spindle *A* will rise a little and the tool be presented approximately as shown in the dotted lines at *g*. It is evident on inspection that the tool *B*, if presented to *A* as in the dotted outline at *g*, would have a tendency to eat into *A* precisely as a graver does if we elevate the handle. A study of these factors will soon convince a thinking workman of the difficulties of accurate turning. Still there is much to learn practically from these facts; as, for instance, by the mere manner in which we set our tool *B*, we can turn our spindle in hand either so it is smallest in the middle (considered longitudinally) or larger in the middle, or what is better, approximate to a true cylinder. But it is essential that all these principles involved should be properly understood and appreciated before a workman can become skillful. We will examine into the action of the cutting tool *B* a little further and see how the advance motion (feed) is going to affect it. The usual form of cutter for turning such cylindrical forms is what is known as a diamond tool, so named from the shape of the cutting point. Such a tool is shown in fig. 1 at *B* as seen in the direction of the axis of the lathe, and at *B\** it is shown as seen in the direction of the arrow *h*, fig. 1. The surface of the beveled point *d* is on a plane parallel to the axis of the lathe, but inclined to a radius of *A* as shown at the dotted line *b*. Now, really the beveled face of the tool *d* should be inclined to the axis of the lathe as shown at the dotted line *k*, fig. 2, which is a plan of the spindle *A* and tool *B* looking downward to fig. 1. If the cutting advance was all in the direction of the dotted line *l*, fig. 2, the form of the tool shown in fig. 1 would be right. But as the advance is in the direction of the arrow *m*, the cutting angle should affect the dotted line *k*. But in consideration of the fact that the cutting tool *B* passes (in the gradual reduction of *A*) back and forth cutting in each direction, a compromise is made and the tool is allowed to remain as shown in fig. 1, although the correct way would be to change the tool for each cut in accordance with the direction of the feed, with the faces of *d* lying alternately in the direction of the dotted lines *k n*, fig. 2. The best evidence that a tool is cutting correctly is a continuous chip of equal size coiling as shown in fig. 1 above *d* with no pronounced tendency to form a spiral. This last remark, I am well aware, is contrary to what is considered orthodox (if I may be allowed the term in connection with a mechanical idea) with machinists, as most of these artisans

### How to Make and Engrave Silver Bangles.

BY EXPERT.

AN ADDITION to our ability to cut bosses or beads by means of our pentagraph is shown in fig. 1. Every bright metal engraver knows how difficult it is to cut bright broad lines on a curve like the base of a cone, as say from *a* to *b*, fig. 2, especially if the curve is a convex one as shown. By means of the device shown in fig. 1 this can be accomplished perfectly. An arbor similar to the cutters formerly described is fitted to the crank *B*, and on the lower end of this arbor *d* is fitted an arm *g*; this arm has a slide *f* carrying a tool *h*. The arm *g* is merely screwed into the upright arbor *d* and secured by the addition of some soft solder. The arbor *d* is put into place from below when the crank *B* is put on and secured with a set screw *l*. The joint through which the arbor *d*

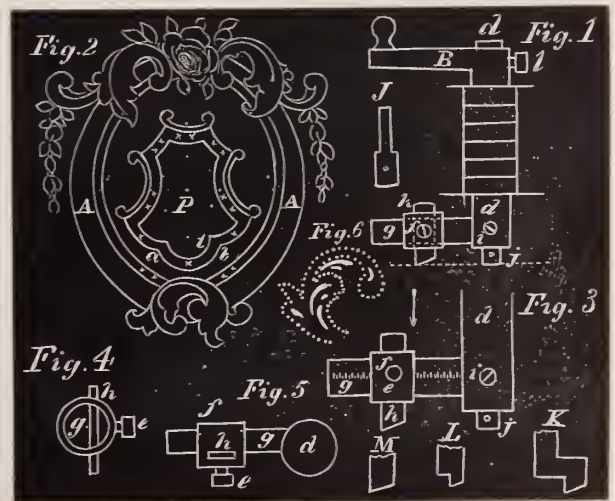

passes is the same as described in last article for the cutters for making beads; in fact, this arrangement is for beads—only larger ones—up to an inch and a quarter in diameter, or, as for that matter, to any size, except the parts should be larger and stronger. A vertical section of the arm and cutter is shown at fig. 4, and illustrates how the set screw *e* clamps and holds the cutter *h* against the

arm *g*. The arrangement of the slide *f* and bar *g* is also shown in fig. 5, which is a plan seen in the direction of the arrow above *h*. The slide *f* is a short piece of steel tube which has an internal diameter equal to the external diameter of the wire from which the arm *g* was made before it was flattened as shown in fig. 4. It will be seen in fig. 5 a mortise through the slide *f* in which the tool *h* goes. It will be seen that when the cutting tool *h* is in place that the flattened face of *g* prevents the slide *f* from turning, and the screw *e* holds the parts rigidly in place. The flat face of *g* can be graduated so as to form a curve of any given diameter. The cutting tools are simply flat pieces of sheet steel about  $\frac{1}{2}$  of an inch thick and  $\frac{1}{8}$  wide, whet beveled at the side as shown in fig. 3. As a usual thing the sizes of curves one wishes to cut with such an instrument will not be less than  $\frac{1}{4}$  of an inch, when the form of tool shown at *L* will answer. By means of a cutter shaped as shown at *K* any curve can be cut down to the size of the set screw head shown at *j*, fig. 3. At *M* is shown the cutter for most work. The screw *j* is shown separate at *J* and has the head quite long extending up into *d*. This screw should not be slotted but provided with two holes by which it can be turned. The hole in *d* in which this screw works should be drilled and tapped after the arm *g* is fitted and in place. A set screw shown at *i* keeps the screw *j* firm. This set screw is only slightly convex and polished on the head, and serves as a guide for depth to which the cutter penetrates. It may be urged against this arrangement that the screw head *j* will mark the job; it may very slightly, but if the cut is made with one sweep of the cutter it cannot be noticed, and usually the cut is only a part of a circle. The smooth round head of the screw *j* extends up into *d* above *i*, so the screw *i* only acts against the smooth part of *j*. Where such patterns as the one shown at fig. 2 have to be repeated, both the convex and the concave curves can be cut by only changing the tool as shown in fig. 3, from the position shown in the full to the dotted lines at *h* and moving the slide on the bar *g*. This moving can be quickly done when the bar *g* is graduated as shown. The effect being to produce a panel at *P* with a bevel edge more perfect than could be made with a graver guided by hand. This style of work can be also done with a properly constructed lathe, but such a lathe would be very expensive and much slower. The cuts should all be made with considerable pressure on the crank *B* producing a full clear incision with one cut. The design shown at fig. 2 is not selected on account of its superior elegance but rather to illustrate the scope of the instrument. Of course, the reader will understand that all the outside ornamentation is hand work, but he will also understand that if the inner curve at *A A* and the panel at *P* was established and cut by this device that the throwing in of the hand ornaments would occupy but a few minutes. By establishing points as spoken of above, I mean if we take our pentagraph as described in April number of this journal, and have pits or recesses in a pattern plate for the point *g* (April number) to go into, we could soon manipulate our cutter so as to produce all the machine work shown in fig. 2. Another method in which our pentagraph can be used to reproduce patterns of flowers and arabesque work in dots is very easily added. This style of work is well adapted for some kinds of silver plated ware. About the only additional expense is a small helix of insulated copper wire. In this day almost every jeweler possesses a battery of sufficient strength to work such a device. The essential features of the last mentioned attachment is a tracing point placed at *g* (April number), following a pattern and an indenting point which goes into the same joint used for the device shown in fig. 1 of the present issue. I shall only be able in this to give a general idea of the device, leaving the details for a subsequent article. The tracing point mentioned above is so arranged as to alternately break and complete the electric circuit and in this way control an electric magnetic device which operates a steel point or *stylus* which produces dots or indentations in the metal at perfectly even intervals as illustrated at fig. 6. A scroll or spray of flowers outlined in this way, heightened by a few judicious bright cuts has a very beautiful

effect and gives the appearance of a great deal of labor, and it also adds a very desirable spice of variety. A few words may not be amiss especially to those dealers who have not a large stock of goods and depend to a great extent on their skill. The rage for silver goods, especially in the bangle way, has not reached its climax; but even the large manufacturers have fallen into the rut of sameness, bright cutting and matting, alternated with matting and bright cutting, and samples and specimens of all degrees of elegance is in abundance. And now is the time for skill to add variety and range to goods shown more than the quantity. In this way the very best class of customers can be reached, and it is about the only way a small stock can be held in competition with a large one; for it is a fact too patent to admit of discussion that four-fifths of the human family will go where they can have the best chance to select for their money. Consequently, skill must come forward with novelties in workmanship and design if he intends to get his share of public favor. And in this way he can do it. We are now just commencing a rage for antique (so called) goods. Some of these articles are exquisitely pretty and artistic, and methods for their production will be discussed in subsequent articles. To enable the reader to unmistakably distinguish which parts of the cuts are made with the pentagraph attachment illustrated, I would say the space between the parallel lines at *t* and *b* shows the width of the beveled cut, and the parts marked with a small x denotes convex curve cutting and two small x indicate concave cutting.

#### A New Method of Engraving Cameos and Intaglios,

*By which the Finer Effect of the Ancient Glyptic Art may be restored, with a Brief Resumé on the History of Gem Engraving.*

ALL TRUE lovers of the fine arts find the study of engraving on gems and other hard stones one of especial interest and value as being one of the evidences of an enlightened age and public prosperity, referring more than any other to an art of refined intellectual luxury, to which at times the vanety and luxury of the age gave the amplest encouragement, in a measure that has not been displayed for the last one hundred years. We find references to it in the Scriptures, Pliny and Theophrastus, and conjectures as to its origin and how it progressed have also been ably discussed in the works of Raspe, King, Billings and Mariette, and a host of other writers. I shall present only a few of these.

At first primæval man having learned to chip and shape his stone tools, and then to polish them, no doubt was often attracted by pretty pebbles, to which we have abundant testimony in the quartz crystals, ground fluorite and other like things found in the mounds. Drilling we have often seen where a core of a hard dolerite or granite could have been removed only with great patience by a hollow reed with sand as a cutting material. Gem engraving was surely suggested later on by the cutting at first in soft stones, after man had become so civilized as to require seals; and among even the very earliest of these we have characters that show a civilization above the Barbarian. The work of savage tribes, such as the jade figures of New Zealand and chalcedony ornaments from Brazil, far exceeded in skill and patience the last named work; but only civilization brought gems and engraved gems into use, possibly from necessity partly, but more from a desire for luxury; whereas the boring and shaping came from necessity only, with a desire to improve their general condition, and in America never led to anything like what could be called gem engraving.

It is possible that in the Eastern countries, owing to their advanced civilization, the diamond was known many centuries before the Christian era, and worked by them in a manner not very different from their present modes. They have at this time only a crude idea of polishing it, although it is cut into all manner of shapes, and often without any regard to faceting. It would follow

that, owing to its lack of color, the Europeans would have paid little attention to it, and that to them the carbuncle, carnelian, amethyst or banded agate would be of more value. Although not used in Europe for gem purposes, it may, nevertheless, have been used for points of tools and for polishing. As to no mention of its origin, ignorance on that question is not, perhaps, to be wondered at, when it is considered how few in this enlightened nineteenth century know where all the different gems come from.

After the hematite, various colored serpentines, limestones, marbles, stealite and lodestone had been used in the form of seals, scarabs and cylinders, and were engraved on. No doubt the discovery of corundum and emery, and their superior cutting power, gave them the means of scratching, drilling and engraving everything they would be likely to have found, except the corundum gems; and later on with the diamond and fragments set in a tool, or powder, it required only the encouragement to perfect gem engraving to the extent it reached.

Sirletti engraved chiefly in this way, and his gems passed for antiques.

Giovanni Pichler, the best engraver of his period, cut some gems with the diamond point merely to show that they could be executed in that way; and one cameo head especially was thought to have been an antique, having deceived the best judges of that day.

The myriads of antique gems are accounted for, as they were put to even more uses than we make of them at present, having been used not only for seals, rings, bracelets, ear rings, necklaces, buckles, clasps, girdles and sashes, but also to dock the gowns of the wealthy of both sexes, as well as the saddles and horse trappings of the warriors of their day.

The deterioration of much of the intaglio and cameo work may have been caused by the fact that competition is so active—the price having much to do with effecting sales; the principal object of the cutters being also to make the most attractive piece with the least outlay of work, all artistic feeling has been lost, and the profession has largely become one for mechanical work alone. Were the proper time allowed to all artists, more work would no doubt be produced that would be artistic and meritorious.

The following references to stone engraving are found in Holy Writ:

And thou shalt take two onyx-stones, and grave on them the names of the children of Israel.

Six of their names on one stone, and the other six names of the rest on the other stone, according to their birth.

With the work of an engraver in stone, like the engravings of a signet, shalt thou engrave the two stones with the names of the children of Israel: thou shalt make them to be set in ouches of gold.

And thou shalt put the two stones upon the shoulders of the ephod for stones of memorial unto the children of Israel: and Aaron shall bear these names before the Lord upon his two shoulders for a memorial.—[*Exodus* xxviii; 9 to 12.

And the stones shall be, with the names of the children of Israel, twelve, according to their names, like the engravings of a signet; every one with his name shall they be, according to the twelve tables.—[*Exodus* xxviii; 21.

And they wrought onyx-stones in ouches of gold, graven as signets are graven, with the names of the children of Israel.

And the stones were according to the names of the children of Israel, twelve, according to their names, like the engravings of a signet, every one with his name, according to the twelve tribes.—[*Exodus* xxxix; 6 and 14.

At the meeting, April 24th, 1883, of the Anthropological Society of England and Great Britain (see *Journal* of same, August, 1883), Mr. W. M. St. Petrie describes and delineates a series of cuttings and drillings—some of the latter from .8 to 1½ inches in diameter—in dolerite, basalt and granite, the entire core still filling the cavity in some cases, and attributes this cutting to the use of a tool with a diamond set in the edge, and the different lines visible to the different rotations of the drill. The discussion of this paper says only the Brazilian carbonado could stand any such pressure, and with this the

Egyptians were not familiar. The interesting fact connected with them, therefore, is that some of these cuttings date from the 4th Dynasty (2400 years B. C.), and show a remarkable skill in the cutting of hard substances.

The lines on the sides were evidently caused by the cleaning out of the cavity or replacing the tool with new powder for cutting.

Theophrastus, in Book XII "of stones that are proper for engraving on," speaks of "some that no iron instrument will touch," and "others that are very difficultly or scarce at all cut by them." In Book XXX he also speaks of "an incombustible stone, the carbuncle, on which they engrave seals; this is from Carthage and Massilia." In Book XXXII, of "an incombustible stone sometimes regularly hexangular, also called the carbuncle." In Book XLIV, in speaking of the emerald, he says, "It is also good for the eyes, for which reason people carry about them seals engraved on it, so as to have them to look at. In Books L and LIV, he speaks of the lapis lyncurius, the hyaloides, the carbuncle, the omphax, crystal and amethyst, and says also that besides these there are many stones used for engraving on. In Book LXXII, speaking of the Armenian whetstone, he thinks it strange that it should take off a part of iron instruments, and yet the instrument may be made to cut the whetstone, although they will not cut the gems which are worked into seals, while the seals are worked with the same matter as the whetstones, or something not very unlike it.

Pliny, in XXXVI-10, says, "In polishing marble statues, and also engraving and filing down gems, the naxium long held the first rank. Thus are called the whetstones (côtes) produced in the Isle of Cyprus.

In Book XXXVII-32, he says, "The peridot is the only precious stone that yields to the file; all others are polished by means of naxium and whetstones."

In Book XXXVI-47, treating of the whetstones used for tools, he repeats these observations as to the naxium, and mentions the superiority of the Armenian. In Book XXXVI-9, he says, "For marble sawing, the best sand was imported from Ethiopia; the next quality from India." Evidently this sand was emery powder.

A. Raspe, in his "Introduction to Tassie's Gems," 1791, says, "With a sharp-pointed stone they might surely scratch straight lines upon the polished surface of those of a softer texture, nay, with such a diamond properly set in a handle, they might make such lines and dots upon the hardest. But is that the art of engraving? It is at best what some antiquarians have ventured to call engraving by the graver (gravure à trait), and that always consists of simple lines and hatchings (hachures). The hardness of the diamond and other hard stones was ascertained after long experiments in the use of powders and sharp points and the art of turning, and especially the drill and wheel must have been brought to some perfection before the lapidary work or real gem engraving could have been accomplished."

In his *Natural History of Gems* (p. 193), Rev. C. W. King says, "The Assyrian cylinders sufficiently explain Pliny's expression in regard to filing down gems, the round form having been produced by rubbing with edge of a fragment of emery, whereas at a more advanced period in the neatly made round indentations we perceive the application of a drill." "The lack of all really antique intaglio by the deep furrows upon them, which are only imperfectly concealed by the lustrous polish subsequently imparted show how the gems had been literally filed by rubbing with an emery stone." "The metal point (p. 198) took no part in the cutting of the intaglio, serving only as a medium in which the acuter particles imbedded themselves, thus bringing an infinite number of cutting points to bear on the gem; hence a bronze drill would cut faster than a steel one." (p. 195). "In addition to the straight cut produced by the emery, the ancients soon found the advantage to be derived from an instrument that could hollow out his figures in hemispherical indentations of the exact size required. The perforations through the length of the cylinders prove that as soon as they were used for signets the drill must have been known to them, this of metal and

not a stick, and turned by means of a bow and this was turned evenly to avoid the risk of splitting the cylinder. The ancient engraver brought his drill to bear on his work and this a filed surface, turning by means of a bow moved by the right hand while he directed his drill with the left; thus only was it possible to work on those enormous cameos which present to the modern eye difficulties almost insuperable by the modern process. More than one artist could have labored simultaneously upon the same sardonyx, the simple drill and bow requiring so little room for their application."

Dr. A. Billing in his Science of Gems, Jewels, Coins, etc., says: "Engraving with the diamond points was practised even after the invention of the engraving lathe, when some parts of the gems were executed by the diamond points, and others by the lathe and diamond dust."

From my first experience in the dental chair dates my impression that a modification of the machine used in tooth drilling would be a proper one for engraving and cutting on stones similar to cameos and intaglios. In the engraving lathe at present used the tool revolves on a horizontal shaft to which are attached the tools of different size and shape, the Italians and French using a screw thread, while the English make use of a lead head which is simply fastened in by the revolving of the wheel. Each class of workmen maintain that in their own method there is less vibration than in that of the others. A set of tools or drills often numbers over 100. The machine which I have here this evening is the S. S. White Improved Dental Engine, kindly loaned Messrs. Tiffany & Co. for experimental trials as to its adaptability to this new use. It is somewhat similar to the old Morrison engine and the new Johnston, all which are covered by many patents, and may be described as follows:

A driving wheel 11 inches in diameter is set in motion by a foot treadle, and from this wheel the power is conveyed by means of a cord of fiber or thin leather to a pulley head; to this is hinged a pivot rod and extending from it as a flexible arm, which conveys the power to the drill through a steel or iron head piece. The main advantage lies in the revolving point being allowed so much freedom of motion by the flexible wire arm that it can be placed in any position desired, and held in any position on the work instead of the work being held on it.

My suggestion lies really in any revolving tool that can be placed at will on the work in any desired position, and this can be attained by a flexible driver as in this machine. I would suggest the following improvements:

1st. The points or drills should be made of softer iron to hold the particles of diamond dust more readily.

2d. The tool should be arranged to work more steadily and thus overcome any possible jar in very fine work, although it has been used for drilling a series of holes in a metal plate, and no engraver with the old lathe could put them more closely together.

3d. The driving wheel should be made heavier and larger than the one in this machine to attain more power and a greater rate of speed.

4th. The wheel and treadle should be placed under a bench and the flexible arm passed through its center in front of the workman.

I would further suggest that with a machine of this kind for all rough grinding out or for some of the fine work, a diamond pointed tool be used such as the one patented by Mr. S. Dessau, of New York, the diamond being the amorphous carbonado; this would in all respects be a miniature rock drill.\*

\* This pointed drill was not likely to have been known to the ancients, carbonado being only of Brazilian origin.

I have no doubt but that with this tool, the diamond being properly secured, any stone softer than diamond could be engraved much more readily than with any known drill, and that for engraving on the diamond it could also possibly be used, since the amorphous diamond is really harder than the crystalline form of this mineral. As engraving on this gem has been much more in vogue of late than ever before, its use in this field also would be required. It would at least be of use in making the round scooped out furrow such as in ancient times were made by the bow drill, and afterward by the diamond or emery stone point, and then polished out by the finer particles of these minerals.

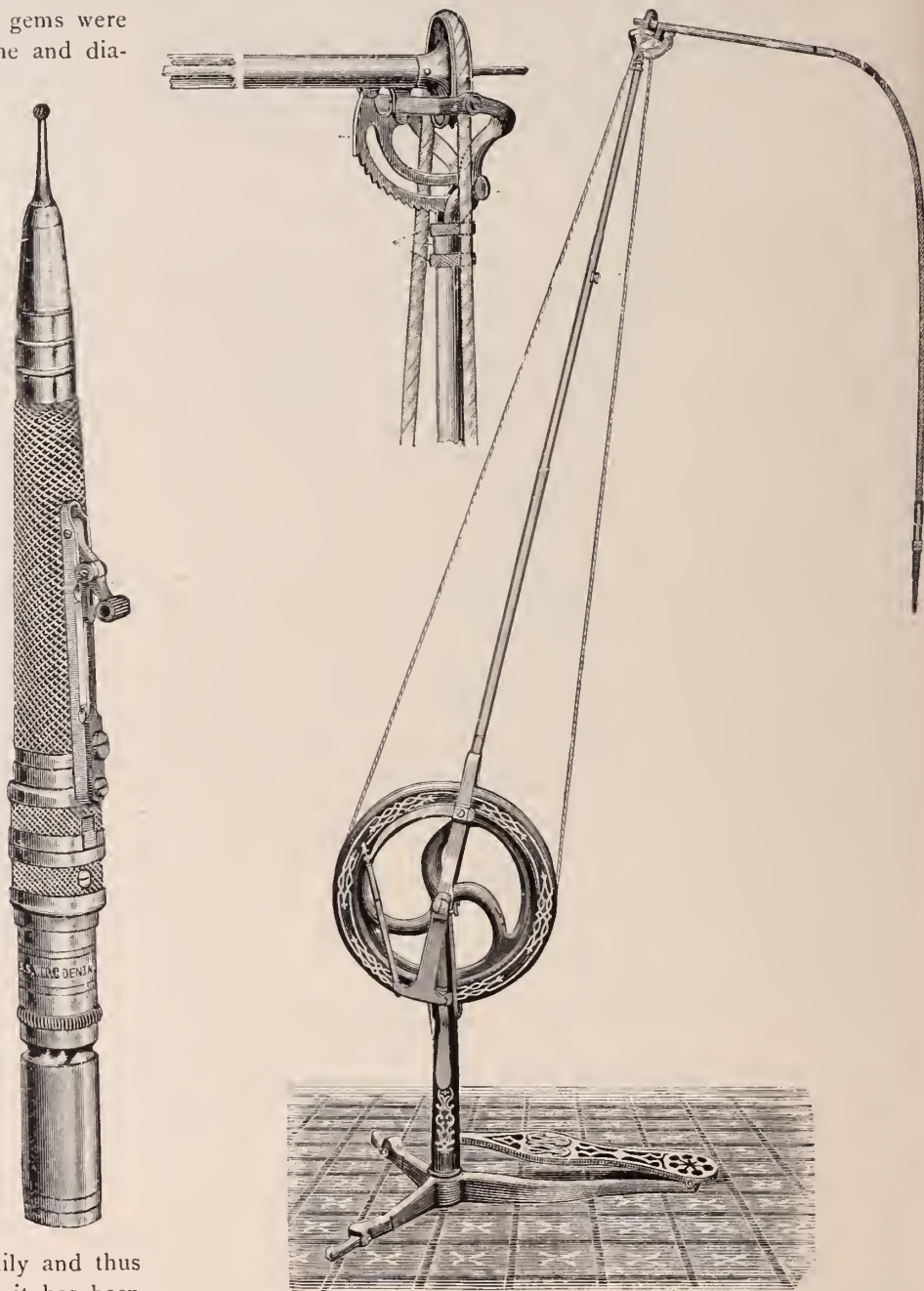

The great advantage, apparently, of this method over any other is that the very pulsation, as it were, of the artist will be conveyed to the drill, thus imparting to the stone whatever artistic feeling he may possess, instead of the mechanical unartistic effect so common with the work of the old machine.

By this method, should it be given a fair trial, not only will the style of work be likely to be greatly improved, but a rapidity of execution will also be attained that has never been accomplished by the old lathe machine even by the best workmen. Those who have always used the present engraving lathe will no doubt not take kindly to so great a change in their mode of working from which they will not depart unless they find that they cannot subsist by the old method, a very unlikely case. The only way, therefore, to properly introduce the machine will be to have beginners learn working

by this only, and rapid improvements would soon follow where a number of men work at any one form of machine. Who would think of a sculptor holding the statue against the chisel, or of a violinist rubbing the bow with the violin? And yet the present mode of work is quite correctly illustrated in these apparently extreme examples. The conveyance of the pulsation through such a machine as this is really the same as the inspiration which a musician or an artist conveys to his instrument, his brush or pencil; it is what he *feels*, and the graver cannot convey this pulsation with the old lathe.

[Copyright Secured.]

### The Cup—Its Art and Customs.

[BY JOHN W. MILES.]

*Continued from page 140.*

THE BANQUETS were conducted with considerable pomp, although amusements of various kinds were introduced, adding to the general enjoyment of the occasion. Mummers were brought in and wandering minstrels were ever welcome. Music was also an accompaniment of the feast, the songs usually extolling the deeds of some brave knight and his fortunes in love or adventure. Health drinking was attended with formality enforced with strictness and ceremony. Each person in turn rose and named some one (not present) to whom he individually drank and emptied his cup. "He that begins the health," we are told in a little book published about this time, "first uncovering his head he takes a full cup in his hand, and, setting his countenance with a grave aspect, he craves for audience; silence being once obtained he begins to breathe out the name peradventure of some honorable personage whose health is drunk to, and he that pledges must likewise off with his cap, kiss his fingers and bow himself in sign of a reverent acceptance. When the leader sees his follower thus prepared he sups up his broth, turns the bottom of the cup upwards, and, in ostentation of his dexterity, gives the cup a fillip to make it cry twango (*i. e.*, to make it ring). And thus the first scene is acted. The cup being newly replenished to the breadth of a hair, he that is the pledger must now begin his part, and thus it goes round throughout the whole company." In order to provide for fair drinking it was a rule that each person in turning up his cup should pour all that remained on his finger nail, and if it was sufficient to run off he was compelled to drink again. This was called *supernaculum* drinking. Pledging one another was a common practice. Master Stephen Perlin, a French physician, who visited England during the reign of Edward VI., writes his countrymen that "the English one with the other are joyous, and are very fond of music; likewise they are great drinkers. Now remember if you please that in this country they generally use vessels of silver when they drink wine, and they will say to you usually at table 'Goude chere,' and also they will say to you more than one hundred times 'Drind oui,' and you will reply to them in their language 'Iplaigne.' They drink their beer out of earthenware pots, of which the handles and the covers are of silver, etc." The doctor's English words are a little peculiar, but we can understand what he means.

The origin of "toasts" appears to have been a singular custom of placing large pieces of toast or roasted pippins in the beverages. Thus Earle Rochester writes:—

"Make it so large that, fill'd with sack  
Up to the swelling brim  
Vast toasts on the delicious lake  
Like ships at sea may swim."

The derivation of this custom is unknown, but the "Tatler" (24) gives a quaint story which, though rather an effect than a cause of the practice, will bear quoting in this connection. "It happened that on a public day a celebrated beauty of those times was in the Cross Bath and one of the crowd of her admirers took a glass of the water in which the fair one stood and drank her health to the com-

pany. There was in the place a gay fellow half fuddled who offered to jump in, and swore though he liked not the liquor he would have the toast. He was opposed in his resolution, yet this whim gave foundation to the present honor which is done to the lady we mention in our liquors, who has ever since been called a *toast*." The Wits chose a lady annually as the recipient of their toasts, writing her name with a diamond on a drinking glass; the signification of the diamond showing that her value was imaginary, and that of the glass to inform her that her condition was frail and depending on the hand that held her.

We come now to the 17th century, and we naturally find the early portion at least recording few changes. An English silver gilt cup of 1611, figure 52, exhibits two plain bands delicately engraved with



Silver Gilt Cup, 17th Century, Figure 52.

hunting scenes. It is a singular adaptation of the classic vase, the cover, stem and even the bowl itself closely imitating the Greek form. The leaven of art that began in Italy had permeated all the prominent countries of Europe, and although new designs rarely appear, the old were reproduced by the pupils and followers of the great artists. This did not long continue. The light and exquisite forms in all the grace of both simple and elaborate beauty gave way to heavy and coarse designs. Articles were valued more for the weight of metal contained in them than for the art displayed in the construction. Worth was estimated by the scales, and prices ruled by that standard. It was as if one were to buy paintings by the square yard. Rarely goldsmiths could be found still struggling for higher expression. Those of Augsburg maintained longest the renaissance influence. Cups with lobes similar to that in figure 44 still continued, and tankards in great variety of both form and decoration were produced, the latter often covered with a mass of engraved and *repoussé* work, figure 53. In fact the goldsmiths appear to have



Nuremberg Tankard, Figure 53.

devoted the greater part of their talents to the creation of tankards, especially in England. They were quite tall, some of them, and intended for either church or secular use, similar ornamentation being

used in both cases. One dating 1634, in the possession of the Corporation of Bristol, is a type of all, figure 54. Foilated arabesques of fruits and flowers fill the spaces between strap-work cartouches, which in turn contain the now familiar sea monsters in relief or *repoussé*. The cover matches. Neither the design nor workmanship display any advance upon the previous century. It was as if genius had exhausted itself and could no longer exhibit its power in the origination of beautiful forms. The history of cups, therefore, loses much of its artistic character and dwindles to a mere record of things



Tankard, English, A. D. 1634, Figure 54.

curious. Not that there was any lack of production or that articles of gold and silver were less used. On the contrary, the houses of the nobility and wealthy classes were filled with great quantities of silver plate, and a large revenue was derived from this source during the wars of Charles I. Heywood, in his *Philocothonista* (1635), says: "Of drinking cups, divers and sundry sorts, we have some of elme, some of box, some of maple, some of holly, etc.," and of plate he says, "Every tarvern can afford you flat bowles, French bowles, prounet cups, beare bowles, beakers; and private householders in the citie, when they make a feast to entertaine their friends, can furnish their cupboardes with flagons, tankards, beere cups, wine bowles, some white, some percell guilt, some guilt all over, some with covers, others without, of sundry shapes and qualities."

(To be Continued.)

## Computation of Time and Changes of Style in the Calendar.

Addressed to Students of History and Genealogy.

[BY SPENCER BONSALE.]

JULIAN AND GREGORIAN CALENDAR.

**M**ORE THAN one hundred and twenty-five years have elapsed since the British Government ordained that a change should be made in the calendar, in order to prevent further errors in the

chronological record of events, by the adoption of the Gregorian, or "New Style," of computing the length of the year, in place of the Julian, or "Old Style," then in use. This law applied to the American and all other colonies of the English Crown; yet there are but few persons, at the present time, who have a clear conception of the meaning of the above terms; and, as the subject has seldom been treated, in the works of reference commonly used, in the manner it deserves, mistakes are frequently made, even by literary men, when writing of past events.

It is unnecessary to enter into an examination of the various calendars that have been in vogue from time immemorial; therefore, I will confine myself to the two now in use by Christian nations.

The solar or tropical year is that period which corresponds to the sun's revolution in the ecliptic from any equinox or solstice to the same again. If the civil year corresponds with the solar, the seasons of the year will always occur at the same period. But prior to the Christian era, the Roman pontiffs, from self-interested motives, added to or took from the year capriciously, so as to lengthen or shorten the period during which a magistrate remained in office, and by this means created such irregularity, that in the days of Julius Cæsar the spring season occurred in what the calendar called summer.

According to Censorinus, quoted by Dr. Smith in his *Dictionary of Greek and Roman Antiquities*, the confusion was at last carried so far that Caius Julius Cæsar, the Pontifex Maximus, in his third Consulate, with Lepidus for his colleague, inserted between the months of November and December two intercalary months, consisting, together, of 67 days, and to the month of February an intercalation of 23 days, which, added to the length of the previous year, 355 days, made the whole of *that* year 445 days, thus bringing the calendar to conform with the seasons. This year was called by Macrobius "the last year of confusion."

Cæsar now undertook the formation of a new calendar. With the assistance of Sosigenes, a famous Egyptian mathematician, he calculated the solar year, which he fixed at 365 days and 6 hours; and, to make allowance for the hours, he determined on the intercalation of one day in every four years, which, being a duplication of the 6th, before the Calends of March, was called the *Bissextile*, or *twice sixth*. That is, the day answering to the 24th of February was counted twice, both days having the same name, which also gives us our term of leap year, which leaps over, as it were, one day more as there are days in a common year.

This was the Julian method of computing time, the reckoning by which commenced in the 45th year B. C., and introduced our present arrangement of having three years of 365 days, followed by one of 366, dividing the year into months nearly as at present.

In A. D. 325, the first Ecumenical or General Council assembled at Nice, in Asia Minor, to deliberate and act on ecclesiastical matters. They composed the *Nicene Creed*, etc., etc., and fixed the days on which Easter and other movable feasts should be celebrated. At that date, the Vernal Equinox, the precise time when the days and nights are equal, fell on the 21st of March, although in the time of Julius Cæsar that event happened on the 25th. Not knowing that the error was in the calendar, but supposing the former date to be correct, and that there would be no variation from it, the Council decreed that Easter day should be "the first Sunday after the first full moon which happened next after the 21st of March. And if the full moon happens upon a Sunday, Easter day is the Sunday after." This rule is still in force.

The calendar of Julius Cæsar was found to be defective, for in the year 1582, the vernal equinox fell on the 11th, instead of the 21st of March. Pope Gregory XIII., assisted by several learned men, made a complete reformation of it. The *Encyclopædia Britannica* gives the name of the author of the system adopted as Aloysius Lilius, or Luigi Lilio Ghiraldi, a learned astronomer and physician of Naples.

The solar or tropical year is found by observation to consist of

365 days, 5 hours, 48 minutes, and 46.14912\* seconds, which not being equal to the year of 365 days, 6 hours, upon which Julius Cæsar established the leap year (the difference, 11 minutes, 14 seconds, amounting in about 128 years to a whole day), Gregory, assuming his fixed point of departure, not A. D. 1, but the year of the Council of Nice, A. D. 325, decreed that *that* year, 1582, should consist of 355 days only (October 5th became October 15th), thus dropping 10 days. And to prevent further irregularity, it was determined that a year, ending a century, should not be a leap year, with the exception of that ending each fourth century. Thus 1700 and 1800 have not been leap years, nor will 1900 be so, but the year 2000 will be. That is, when a centesimal year is divisible by 400, without a remainder, it is a leap year, and when there is a remainder, the year consists of 365 days only. In this manner, three days are retrenched in 400 years, because the lapse of 11 minutes and 14 seconds makes three days in about that period. All other years in the century divisible by 4, without a remainder, are likewise leap years. The Bull which effected this change was issued February 24, 1582.

The year of the calendar is thus made, as nearly as possible, to correspond with the true solar year, and future errors in chronology will be avoided, as the difference will not amount to much more than a day in 3342 years, or until A. D. 3667, counting from the Council of Nice.

The Catholic nations, in general, adopted the *style* ordained by their sovereign pontiff,† but the greater part of the Protestants, with the exception of a portion of the Netherlands, were then too much inflamed against Catholicism, in all its relations, to receive even a purely scientific improvement from such a source. The Lutherans of Germany, Switzerland, and the remaining parts of the low Countries at length gave way in 1700, when it had become necessary to omit *eleven* instead of ten days, in consequence of their having made that year a leap year.

It was not until 1751, and after great inconvenience had been experienced for nearly two centuries from the difference of reckoning, that an act was passed (24 Geo. II. c. 23, 1751) for equalizing the style in Great Britain, Ireland, and the Colonies with that used in other countries of Europe. It was then enacted that eleven nominal days should be omitted; the last day of *Old Style* being Wednesday the 2d, and the first of *New Style* (the next day) Thursday the 14th, instead of the 3d of September, 1752, and the legal year, which had previously been held to begin with the 25th of March, was made to begin on the 1st of January. The Gregorian regulation of dropping one day in every hundredth year, except the fourth hundred, was also included.

The alteration was for a long time opposed by the prejudices of individuals; and even now, in some instances, in England, the old style is so pertinaciously adhered to, that rents are made payable on the old quarter days, instead of the new.

Assuming the calendar to have been correct at the time of the Council of Nice, the first centesimal year, A. D. 400, which occurred only seventy-five years later, should not have been made a leap year, but as it was, the first excess of one day took place. The following table, omitting the centuries 800, 1200, and 1600, which were properly leap years, will show the difference which must be allowed in the respective periods, for changing *Old Style* to *New Style*:—

|  |            |
|--|------------|
| From March 1st, A. D. 400 to March 1st, A. D. 500, | omit 1 day |
| “ “ “ “ 500 to “ “ “ 600,                          | “ 2 days   |
| “ “ “ “ 600 to “ “ “ 700,                          | “ 3 “      |
| “ “ “ “ 700 to “ “ “ 800,                          | “ 4 “      |
| “ “ “ “ 800 to “ “ “ 900,                          | “ 5 “      |
| “ “ “ “ 900 to “ “ “ 1000,                         | “ 6 “      |
| “ “ “ “ 1000 to “ “ “ 1100,                        | “ 7 “      |
| “ “ “ “ 1100 to “ “ “ 1200,                        | “ 8 “      |
| “ “ “ “ 1200 to “ “ “ 1300,                        | “ 9 “      |
| “ “ “ “ 1300 to “ “ “ 1400,                        | “ 10 “     |
| “ “ “ “ 1400 to “ “ “ 1500,                        | “ 11 “     |
| “ “ “ “ 1500 to Sept. 2d “ 1752,                   | “ 11 “     |

\* I am indebted to Professors Nourse and Hall, of the United States Naval Observatory, Washington, D. C., for the exact length of the solar or tropical year, which is given from the most reliable data, as 365.2422008 days = 365 d. 5 h. 48 min. 46.14912 sec. This varies a few seconds from previous calculations, affecting only the length of time when the difference will amount to a day.

† Chambers' Encyclopædia.

The change of *eleven* days in the last century, required to reduce old style to new, has been the cause of many mistakes, made by thoughtless persons, who apply that difference to all past time. All events require a correction, respective of the *time* of their occurrence. For example: Columbus discovered America on Friday, the 12th day of October, 1492, o. s., by the New Style this event happened on Friday, October 21, 1492, a difference of *nine* days only being made, as will be observed by reference to the table. Again, William Penn “arrived before the town of New Castle, in Delaware,” on Friday, October 27, 1682, o. s., which reduced to n. s. is Friday, November 6th, *ten* days being then the difference, and in the next century, to take a familiar example, Washington was born on Friday, the 11th of February, 1732, and, as all the world knows, we celebrate the anniversary of his birth on the 22d of February, in this case properly omitting *eleven* days, as required by the act of Parliament.

Russia, and the countries following the communion of the Greek Church, are now the only ones which adhere to the Old Style, an adherence which renders it necessary, when a letter is thence addressed to a person in another country, that the date should be given thus: April 1<sup>st</sup> or  $\frac{\text{June } 27}{\text{July } 9}$ , for it will be observed that the year 1800, not being a Gregorian leap year, has interjected another (or twelfth) day between old and new style. Earlier examples of double-dating may be found in the “Documents relating to the Colonial History of New York,” vol. III., thus 1<sup>st</sup> of 9<sup>ber</sup>, and  $\frac{13\text{th}}{2\text{d}}$  10<sup>ber</sup>, 1665, etc., etc. The months September, October, November and December, were frequently written 7<sup>ber</sup>, 8<sup>ber</sup>, 9<sup>ber</sup>, and 10<sup>ber</sup>, or in Roman numerals.

(To be Continued.)

## The History of Goldsmithing.

### I. ANTIQUITY.

WHENEVER the student is engaged in searching the pages of history to trace the origin of any art, whatever be its name, and running backward into the remotest ages, he will nearly always find its cradle in Egypt and the first indications thereof mentioned in the Holy Writ.

This is a well known fact, and thanks to the surprising discoveries daily made by our scientific men in that mysterious country, we are enabled to fix its chronology with great precision, almost up to the very date when the fiat went forth, “Let there be light, and there was light!” By reason of its peculiar climate and soil, Egypt, more effectually than any other country of the world, has been able to preserve intact up to our date its gigantic monuments, the precious relics of a civilization the beginning of which is lost in the night of time.

Each day some bold and intelligent explorer makes new discoveries, and unearths some treasure consisting of a multitude of objects which, after an interment of more than forty centuries, have been preserved to us in as good a condition as if they had been sepulchred only the previous evening.

At the Paris Exposition of 1867, the Egyptian section, filled with highly interesting objects, contained a glass case with the treasure then recently taken from the catacombs of the Queen Aah-hotep, wife of the last king of the sixteenth dynasty who lived in the seventeenth century before our era. Her tomb had contained a veritable museum of art—an endless variety of gold and silver trinkets. Beside the great number of articles for personal adornment, such as diadems, breast plate, chains, necklaces, bracelets, rings and armlets, it also contained several gold and silver hatchets, a large axe, poignards with gold blades, etc., a small bark wrought of solid gold, and of exquisite workmanship, mounted upon a four-wheeled running gear.

The bark is furnished with its crew and made of solid gold. The

oarsmen, twelve in number, are of solid silver. A small figure is seated in the center of the bark holding the hatchet and staff of authority. Another person stands in the bow in a kind of small cabin. The steersman at the stern handles a wide bladed oar. These last three figures are of gold. Both the bow and the stern of the bark gracefully curve upward and terminate in bunches of papyrus. The whole is mounted upon a chariot, the running gear of which is of wood; the wheels are of bronze.

It is known that the Egyptians believed in a future life, and this bark found in the tomb was evidently a symbol to insure the safe passage of her soul.

The great elegance and artistic execution sufficiently attest that this piece of workmanship was not the first essay of working in the precious metals. According to verified data, civilization, more especially that of the Egyptians, was at that time fully two thousand years old and ascended into the fourth dynasty. This is fully supported by the marvelous monuments found at Memphis.

The museum of the Louvre at Paris also lately received the addition of a very interesting group of gold, representing the trinity of the divine Osiris, Iris and Horus. The name of the king Osorkon II. is engraved on this group, which fixes the date at the tenth century before our era.

It may be well asked, where did the Egyptians obtain their education in the principles of this art so prodigiously old? The question will, perhaps, never be answered.

The oldest record which we have on the subject of goldsmithing is the ancient Testament, and the first mention remounts to the time of Moses. Everyone has read the chapter xxvi. of Exodus, in which are found with many details the instructions given by the Lord Himself to His servant respecting the construction of the holy ark. Above the ark, covered with sheets of gold, He ordered that a crown of the same metal be suspended, also that there be made a gift offering of the purest gold, for the exact record of which we refer the reader to the chapter quoted.

It will readily be acknowledged that the command given by the Most High concerning the construction of the ark could not have been either directed to or executed by a pastoral people or by poor fugitives momentarily encamped on the limits of the desert, and it would be necessary to believe in a miraculous intervention of Jehovah to give unto his people the skill of complying with his commandment; but we know that very close to the encampment of the Israelites, very close to Sinai, where Moses received the orders of the Most High, at a place at present called Oualy-Magarah, important gold mines existed, very anciently worked by the Egyptians who had also workshops there, the traces of which still exist.

Either the Israelites, at that time the masters of the country, expelled the Egyptian workmen to take possession of the workshops or else they forced the latter to work for them; it is most probable that they found at said place the most necessary resources to comply with the commandment of the Most High. It is beyond a doubt that the principal workmen belonged to the Jewish nation, and the Bible has preserved us the names of two of them, to wit: Besaleel and Aholiab.

Several ancient authors appear to think that also the golden calf was made in the shops of Oualy-Magarah, but this supposition cannot be supported by probable facts.

However, the people of God, at that time barely liberated from a slavery which, on a whole, had not been spent without teaching them valuable lessons, were still destined to see several centuries elapse before they had reached the apogee of their prosperity. Their arts finally shown in their full luster a thousand years before Christ, during the first part of Solomon's reign. The descriptions left us of the truly Oriental splendor of this monarch might, of good rights, appear to us to be fabulous, if, on the one hand, it had not been attested to by the Holy Writ, and, on the other hand, if we did not know from other examples with what profusion the precious metals were employed by all the Oriental princes of this remote epoch.

The Book of the Kings tells us that Solomon only drank out of the purest gold cups, and every vessel of the house of Mount Lebanon was also of gold and "not of silver," the sacred text remarks, because under his reign silver possessed but little value. He had made two hundred bucklers overlaid with sheets of gold, and the weight of a single one was estimated at six hundred ounces, and three hundred other bucklers of smaller dimensions. According to the text of the Book of Kings, his throne was of ivory ornamented with pale gold. This additional explanation shows that the processes of goldsmithing were already sufficiently advanced at this period that the goldsmiths could make use of differently colored gold.

But the most durable monument of the splendor of Solomon's reign was the famous temple of Jerusalem which he constructed according to the directions of King David, his father. Nothing could surpass its magnificence, for a full description of which we must also refer the readers of THE CIRCULAR to the Holy Writ.

Such a lavish display of wealth could not fail to excite the cupidity of man. It is the inevitable fate of all treasures to be pillaged sooner or later; only by being hidden can they hope for a length of time to escape man's rapacity. The treasures of the temple remained at Jerusalem for six centuries, in order to fall as booty into the hands of the soldiers of Titus who carried it to Rome.

The art and civilization of Tyre are so well known by the student of history that it is unnecessary to burthen our readers with a description, and it suffices to state that all the recent discoveries in the Orient prove incontestably that the art of goldsmithing had assumed vast proportions and can be traced from the present day of civilization to the early dawn of remote period, until the eye can discern nothing further in the obscurity of the night.

Undoubted traces of our art have been recorded in the prodigious cuneiform inscriptions of Assyria, which, as is generally known, are a recital of the pomp and honors of some sovereign of antique Syria, the enumeration of his victories, his acts of piety and his wealth. Many of these inscriptions have already been decyphered and translated either wholly or in part; to this number pertains the immense and magnificent inscription of Korsabad, known by the name of the "Songs of Sargon," at present in the Louvre of Paris.

The prince of this name lived in the eighth century before our era. His power was great, and by the very detailed account which he has left us of his reign we learn that his riches were immense, and that those of the princes whom he vanquished were not less wealthy. He himself tells us that he propitiated the wrath of the gods by immense votive offerings, heavy trinkets that he has lavished on his lieutenants, on his satraps, gold and silver, vases of gold and silver, precious stones, immense riches. And, in fact, it appears to have been easy for him to be prodigal to judge by the prodigious quantity of booty which he boasts to have received in his warlike expeditions. To simply mention an example: The King of Chaldea, Merodach Baladan, by reason of an unsuccessful battle with the former, was obliged to deliver as spoils of war his gold throne, tiara, scepter and parasol of the same metal, his silver chariot, beside endless number of gold trinkets of a considerable weight.

In another inscription recently decyphered, King Assurdanipal, recounting his second war against Ummaldas, mentions among the booty obtained of horses and mules, the harness of which was covered with gold and silver.

We have in the preceding pages given a cursory glance at the principal events mentioned in Holy Writ and profane works, deeming the synopsis necessary to begin our "History of Goldsmithing" with the remotest times. Much more could be mentioned—the accounts given by Herodotus, etc. It must be confessed that many of these ancient accounts appear to be fabulous, and we next pass into an examination of the written and fully authenticated history, beginning our account with

#### GREECE.

At the epoch of their war against the Persians, the splendors of



goldsmithing were well known to the Greeks. The most ancient records of their literature sufficiently attest that, at least, they were conversant with all its processes, and if the struggle for existence prevented them from following the peaceful pursuits of art, they bartered trinkets in their commerce with Asia. We refer the student to Homer in his description of the shield of Achilles, or in Hesioid to that of the armor of Hercules.

(To be continued.)

### The Jewelers' Security Alliance.

President, DAVID C. DODD, JR.

Vice-President, AUGUSTUS K. SLOAN.....Of Carter, Sloan & Co.

Treasurer, W. C. KIMBALL.....Of H. F. Barrows & Co.

Secretary, C. C. Champenois.....Of Champenois & Co

#### EXECUTIVE COMMITTEE.

C. G. ALFORD, *Chairman*.....Of C. G. Alford & Co.

C. B. BISHOP.....Of Carrow, Bishop & Co.

HENRY HAYES.....Of Wheeler, Parsons & Hayes.

J. B. BOWDEN.....Of J. B. Bowden & Co.

DAVID UNTERMAYER.....Of Keller & Untermeyer.

E. F. DORRANCE.....Of Dorrance & Brother.

P. O. Box 3277.

Room 2, 170 Broadway, New York.

HON. ALGERNON S. SULLIVAN, *Counsel.*

A meeting of the Executive Committee of the Jewelers' Security Alliance was held at the office of the Alliance on May 24th and on June 6th, 1884.

The resignation of Mr. H. W. Hiller as Secretary was received and accepted, and Mr. C. C. Champenois, of Champenois & Co., was elected Secretary for the ensuing year.

The following members were elected to act as members of an Advisory Board, namely:

D. C. Percival & Co., Boston, Mass.; S. E. Fisher & Co., North Attleboro, Mass.; Hennegen, Bates & Co., Baltimore, Md.; H. Muhrs' Sons, Philadelphia, Pa.; D. F. Conover & Co., Philadelphia, Pa.; Hodge, Slemmons & Co., Pittsburgh, Pa.; Sigler Bros. & Co., Cleveland, O.; Duhme & Co., Cincinnati, O.; C. H. Knights & Co., Chicago, Ill.; H. F. Kahn & Co., Chicago, Ill.; B. F. Norris & Co., Chicago, Ill.; L. Bauman Jewelry Co., St. Louis, Mo.; Chas. Downs, Providence, R. I.

The duties of the above being to keep applications on hand, furnish information, etc.

The following were admitted as members of the Alliance.

L. Bauman Jewelry Co., St. Louis, Mo.; A. L. Desbouillons, Savannah, Ga.; Duhme & Co., Cincinnati, O.; D. F. Fero, Corning, N. Y.; A. M. Hill, New Orleans, La.; S. P. Hamilton, Savannah, Ga.; E. H. Hobbs, Selma, Ala.; R. N. Aershfield, Leavenworth, Kan.; J. B. Hoecker, Brooklyn, N. Y.; John F. Jarvis & Son, Mt. Vernon, N. Y.; C. B. Jacquemin & Co., Council Bluffs, Ia.; C. H. Knights & Co., Chicago, Ill.; P. L. Miles & Co., Cleveland, O.; H. Mahler, Raleigh, N. C.; F. P. Nuse, Titusville, Pa.; Sigler Bros. & Co., Cleveland, O.; B. & C. B. Wilsey, Sandwich, Ill.

### The Jewelers' League.

President, GILBERT T. WOGLON.....Of Woglom & Miller.

First Vice-President, WM. C. KIMBALL.....Of H. F. Barrows & Co.

Second Vice-President, AUG. KURTZBORN.....Of L. Bauman Jewelry Co. St. Louis, Mo.

Third Vice-President, JAMES P. SNOW.....Of G. & S. Owen & Co.

Fourth Vice-President, HENRY HAYES.....Of Wheeler, Parsons & Hayes.

Secretary and Treasurer, WILLIAM L. SEXTON.....Of Sexton & Cole.

#### EXECUTIVE COMMITTEE.

ROBERT A. JOHNSON, *Chairman*.....Of Colby & Johnson.

SAMUEL W. SAXTON.....Of Saxton, Smith & Co.

CLEMENT B. BISHOP.....Of Carrow, Bishop & Co.

JOSEPH B. BOWDEN.....Of J. B. Bowden & Co.

GEORGE R. HOWE.....Of Carter, Sloan & Co.

CHARLES G. LEWIS.....Of Randel, Baremore & Billings.

THE JEWELERS' CIRCULAR is the exclusive official paper of the Jewelers' League, and has been selected for the publication of all matters of interest pertaining thereto. Letters or inquiries pertinent to its business or purposes, and which might interest the trade or inquirers, will herein be answered. Address *Jewelers' League, Box 3,444, P. O., New York*, or the office of THE CIRCULAR.

IN OUR December number, commenting on the extravagant expenditures of the scalping insurance associations, those that are managed by speculative ex-insurance agents and officials, we stated that

one of these associations, with an impressively high-sounding title, had, for the fiscal year ending December 31st, 1882, spent \$3.28 to place each single dollar in the hands of beneficiaries. One of these associations now raises the cry of "stop thief," and joins in a chase after the old line companies in order to show a possible contrast between the expenditures of the two classes of institutions. A journal published in the interest of the speculative association has taken the trouble to show from the reports of all the "old liners" for each year from 1863 to 1882 inclusive, that the companies received during 1882 nearly four thousand dollars (\$3,955.17) for each thousand paid to beneficiaries, while the mutual benefit and assessment societies combined averaged \$134.61 per thousand dollars of benefit. This comparison shows well for the speculative concern (which is classed with the mutual benefit societies), by using the known small expenses of our pure mutual benefit societies, in order to cut down the otherwise high average and then parade the low average in its favor.

We show here for the benefit of all concerned the difference between the economy of one and the extravagance of the other class as compiled from the last report of John A. McCall, Superintendent of Insurance Department of the State of New York:

| NAME OF ASSOCIATION.  | Am't paid to Beneficiaries. | Expense of Management. |
|---|-----------------------------|------------------------|
| American Co-operative Relief Association, Syracuse, N. Y.....           | \$ 28,241.25                | \$ 6,542.35            |
| Catholic Benevolent Legion, 26 Court St., Brooklyn, N. Y.....           | 19,686.09                   | 3,224.97               |
| Cincinnati Life Association, Cincinnati, Ohio.....                      | 21,539.63                   | 11,298.18              |
| Commercial Travelers' Association, Syracuse, N. Y..                     | 170,000.00                  | 7,448.39               |
| Jewelers' League, 170 Broadway, N. Y.....                               | 20,892.50                   | 2,917.14               |
| Masonic Guild and Mutual Benefit Association, 192 Broadway, N. Y.....   | 9,851.73                    | 5,822.99               |
| Massachusetts Benefit Association, Boston, Mass....                     | 191,000.00                  | 70,819.57              |
| Mercantile Benefit Association, 319 Broadway, N. Y.                     | 55,000.00                   | 8,457.68               |
| Mutual Aid and Accident Association, Rochester, N. Y.....               | 33,154.51                   | 17,444.20              |
| Mutual Relief Society, Rochester, N. Y.....                             | 128,530.36                  | 58,788.87              |
| Mutual Reserve Fund Life Association, 55 Liberty St., N. Y.....         | 301,425.00                  | 236,251.23             |
| New York National Mutual Aid Society, Rochester, N. Y.....              | 50,000.00                   | 22,073.57              |
| New York State Relief Association, Albany, N. Y..                       | 17,639.87                   | 6,768.86               |
| New York State Mutual Benefit Association, Syracuse, N. Y. ....         | 13,244.20                   | 12,512.58              |
| People's Benefit Association of the State of N. Y., Syracuse, N. Y..... | 33,948.12                   | 3,701.51               |

Comment is unnecessary except to call attention with pride to the fact that our own Jewelers' League transacted its business at smaller expense than any other association.

Since the founding of the League it has been the means of distributing over one hundred thousand dollars to widows and orphans of its members.

The League is now the possessor of permanent and contingent funds composed of the following named securities which were, much of them, purchased during the recent depression in prices of such securities, and reflect credit upon the Trustees for the good judgment used in selection and investment:

Five U. S. Government Bonds, maturing in the year 1907, denomination one thousand dollars each, bearing four per cent. interest.

One New York County gold bond, maturing in the year 1901, for three thousand dollars, six per cent. interest.

One New York City gold bond, maturing in 1901, for five hundred dollars, at six per cent. interest.

One U. S. Government Bond, coupon, maturing in 1904, denomination fifty dollars, at four per cent.

These, aggregating \$8,550 face value, are investments made in rigid adherence to the constitutional provisions, are now ticking away at interest in the safe deposit vaults of the Nassau Bank, can be removed only by the presence of three appointed trustees acting in unison, with the exception of the last named which is a donation, are all registered in the name of the Jewelers' League of the City of New York, and can be negotiated or sold only after certification by the President of the League. The safeguards thrown around the funds

of the League are in the same excellent business form which characterizes the entire management of the League, and which places the institution so high in the estimation of the trade and the public. The graceful allusion by President David C. Dodd, of the Jewelers' Security Alliance, to the Jewelers' League in the course of his address to the Alliance, appears to be appreciated by the officers and members of the League, and is in consonance with the sentiment of everyone who has observed its prudent management.

The Executive Committee are gratified by the indication of interest taken by the lay members in the progress and safety of the League, as evinced by occasional advice by letter as to the standing of applicants for membership, and it is the wish of the Committee to encourage that interest. All such communications will be treated in confidence for mutual benefit.

President Woglom desires us to repeat and re-enforce the injunction which has more than once appeared in this column, that members should as promptly as practicable after the decease of any beneficiary (whether it be the sole or partial beneficiary), notify the Executive Committee of such decease, and name another beneficiary on the printed forms which are furnished for the purpose. In order to save probable, nay, almost certain litigation, there should not appear on the records of the League the names of any but living, existing beneficiaries. Each member should immediately heed this injunction if he desires to have the League carry out his intentions as to his beneficiary or beneficiaries. They should be specifically named and living at the time of the death of the member.

A regular meeting of the Executive Committee was held on Friday evening, June 6th, in the new office of the League, No. 170 Broadway, corner of Maiden Lane. There were present President Woglom, Vice-Presidents Kimball and Snow, Secretary Sexton, Chairman Johnson and Committeemen Howe, Bowden, Bishop, Lewis and Saxton.

A balance of \$2,063.04 was shown in the general fund and a triple assessment in course of collection. Dr. E. A. Robertson was appointed medical examiner at Dayton, O.; five delinquent members were re-instated after furnishing satisfactory explanations; four requests were granted for change of beneficiaries, eight applicants were rejected, six were tabled for investigation of obscure replies, and the following 35 were admitted to membership:

E. Bloch, H. Ehrman, S. H. Fink, G. Green, T. Peiter, D. I. Reynolds, A. W. Woodhull, N. Y. City, N. Y.; P. W. Carter, Boston, Mass.; G. O. Hill, Taunton, Mass.; C. D. Rood, Springfield, Mass.; W. E. Keer, W. Link, J. C. F. Merz, Newark, N. J.; W. Mayhew, S. S. Woodbury, Philadelphia, Pa.; C. G. Weber, Pittsburg, Pa.; F. Morck, Warren, Pa.; H. C. Fravel, Luray, Va.; W. G. Bancroft, Columbus, Ohio; F. Bower, Chicago, Ill.; J. T. Buker, R. W. Skinner, Rockford, Ill.; H. B. Meader, Ravenswood, Ill.; H. B. Morgan, Lansing, Mich.; C. E. Abbott, Lake Geneva, Wis.; A. Michael, Green Bay, Wis.; J. Morganstern, St. Paul, Minn.; D. S. Jones, Independence, Iowa; H. K. Herbert, Iola, Kan.; A. Mandelberg, D. W. Van Cott, Omaha, Neb.; O. M. Cornitius, Brenham, Texas; W. B. Miller, Sacramento, Cal.; J. W. Blauer, R. Kocher, San Jose, Cal.

The comparatively few members who are dishonorably dropped from the roll is a matter of comment and congratulation, especially in view of the trying times through which we have, in some sections of our country, been recently passing. Those who are dropped become so through carelessness and indifference, rousing themselves when they are notified of the laws having been rigorously enforced, and then applying for a resumption of their privileges in the League.

The membership is now nearly 3,300.

### The Goldsmith.

[By JOHANNES PRETZLAFF, Dresden.]

*Continued from Page 155.*

**CONTACT SILVER-PLATING.**—1 part chloride of silver, 5 parts prussiate of potash, 5 parts carbonate of potash, 5 parts sal ammoniac, 2 parts purified table salt are boiled for 1 hour in about 50

parts of water, replacing the evaporated water; the silver-plating fluid is then left to stand for some time, the supernatant liquor decanted from the sediment and filtered. For use, the silver-plating fluid is heated and employed in the same manner as gilding.

**SILVER-PLATING BY RUBBING.**—A finely pulverized mixture of 10 parts chloride of silver, 10 parts table salt and 30 parts cream of tartar are moistened with water and rubbed on with a rag or cork. Or else a mixture of 1 part chloride of silver, 8 parts cream of tartar, 1 part table salt and 1 part alum; or, 1 part chloride of silver, 6 parts cream of tartar and 1 part calcined alum.

**FIRE GILDING AND SILVERING UPON STEEL AND IRON.**—The article to be gilt is "quicken" by rubbing sodium amalgam upon it; chloride of gold in concentrated solution is next quickly applied upon the amalgamated surface, and the quicksilver is permitted to evaporate upon the hearth. The article may in this manner be ornamented with sketches by painting the surface with the solution.

With silver-plating by fire the process is the same, only with this difference, that in place of chloride of gold chloride of silver is used.

**GALVANIC GOLD AND SILVER-PLATING UPON STEEL AND IRON.**—Steel and iron must be coppered before the galvanic gilding, and the simplest manner is by washing the article with sulphate of copper, dissolved in water. It is better, however, to copper it in the galvanic bath.

**GALVANIC COPPERING.**—The process for coating with copper by galvanism is the same as that of gilding, only instead of a gold solution a copper solution is placed in the clay cylinder.

Either sulphate of copper is dissolved in nitric acid and diluted largely with water, or else for 1 part of sulphate of copper dissolved in water, 8 parts of cyanide of potash and 100 parts water are taken.

**GALVANO-PLASTIC SILVER PRECIPITATE.**—The articles are first washed in a solution of nitrate of silver, so that a thin film forms over the entire surface. When the article is dry it is exposed to a current of sulphuretted hydrogen, whereby the produced coating is made conductive. When the article is then placed in a silver bath and connected with the galvanic battery, the silver precipitate will very firmly adhere to it.

Should the nitrate of silver not adhere to an article, cover its surface first with a solution of gum Arabic.

In this manner, also articles of stone, wood, horn, etc., may be coated with a galvano-plastic coating.

### ENAMELING.

When an enameler is convenient it is better to apply to him; this, however, cannot always be done, since they generally live only in large cities, and for obvious reasons a piece of work cannot always be sent to them. In such cases it is well to be able to help yourself and any skillful man will soon attain the necessary skill. We therefore desire to give a simple and practical description of the method.

The enamel is a glass that fuses at a lower degree of heat than the ordinary kind; it is manufactured in so many ways and of so many different compositions that it would lead us too far to enter into exhaustive details. Let us state only that the basis consists generally of silica (quartz powder or white sand), carbonate of soda and oxide of lead (minium of white lead), and the different colors are produced by metallic oxides, and, consequently, they are of a metallic nature.

The colors of the enamel are liable to change on silver, and on copper they will generally turn blackish and greenish around the edges; to prevent this, a ground of white enamel is put on first. The colors do not change on gold, wherefore it is suited best for the purpose; reddish gold is the handsomest of all alloys.

To prevent the chipping out of the alloy, always prepare a fresh alloy of gold to be of at least 14 karats. To prevent the chipping of the enamel on hollow articles, strengthen them from behind with so-called counter enamel.

After the pattern or sketch has been engraved upon the article, roughen the bottom of the design with lines to enable the enamel to adhere better. Appropriate additional lines may also be engraved that impart a nice shading underneath the transparent enamel, which is very effective, especially with fine silver. The article is then glow-heated feebly and boiled in a nitric acid pickle; the enamel is now reduced to powder by grinding in a dish, using a hard pestle (agate is best) for the purpose; the superfluous water is poured off and the enamel applied with a small tool with a broad end or a brush, spreading it very uniformly in the engraving or on the surface. When this has been done the water is drawn out as nearly as it can be done by gently applying blotting paper to it.

For want of an enameling furnace pick out two good pieces of charcoal, hollow out both of them in a manner similar to a smelting coal, and make a hole in front for blowing in the flame with the blowing pipe; burn out the hole well with the blow flame, blow out the ashes and make a frame of iron wire upon the lower coal, upon which is to rest the article to be enameled.

When the covering coal has then been placed on and the article gradually heated with the blowpipe and flame, apply a strong heat so that the enamel fuses nicely but not direct; let the flame play around the article. Oil lamps, etc., are not suitable for enameling, as they produce scot; a pure alcohol flame is the best.

When done the article is not at once withdrawn from the coals, but left to cool off gradually; if cooled too quickly the enamel would be apt to crack.

Should there be bad places enamel is applied to them and fused. If necessary, the enamel is finally filed smooth with a medium rough but sharp and wet file, and the file strokes are ground out with a stone.

The luster is restored to the enamel by the so-called luster fluxing, that is, the article after having been well cleaned and dried is again heated, but no more than is actually necessary. The luster may also be given to enamel by grinding with washed tripoli and water upon a basswood or lead disc in the turning tool.

**TO REMOVE ENAMEL.**—If enamel has to be removed from a piece of work, either on account of ill-success or other reason, put on a powder of equal parts saltpeter, table salt and alum, glow-heat the article and plunge in cold water.

**COLD ENAMEL.**—The so-called cold enamel is generally used for repairs. The different colors are either stirred in with copal varnish and a trace of oil of turpentine, or they are fused together with gum mastic and a trace of oil of spike. When using the former the surface is apt to settle down, and the latter method is in general to be preferred; a sufficient quantity is applied to the chipped-out place of the article; this is heated and the enamel permitted to run. After cooling the cold enamel is filed down even, and the luster is restored by rapidly drawing through a flame.

For black cold enamel gum mastic is melted with lamp black, which is easily obtained by permitting the flame of a wick dipped in linseed oil to smoke against a metallic plate.

White: With white lead or flake white.

Red: With carmine or vermilion.

Blue: With ultramarine or Prussian blue.

Green: With Swedish or Swinefurd green.

Brown: With umber.

Yellow: With ochre or chrome yellow.

Various other shades are produced by mixing.

**NIELLO.**—The mixing proportions of niello vary greatly without causing an essential difference. It consists of 2 parts fine silver, 4 parts pure copper, 6 parts lead, 18 parts sulphur and 4 parts sal ammoniac; or, 2 parts fine silver, 5 parts copper, 3 parts lead, 1 part borax and 24 parts sulphur; or, 1 part fine silver, 2 parts copper, 3 parts lead and 12 parts sulphur.

The silver and copper are first smelted together, the lead is then taken between the fire tongs and held suspended over the crucible until it has fused and dropped in; the mass is poured into another

crucible containing the powdered sulphur and sal ammoniac, re-melted another time with these ingredients, after which the mixture is granulated.

The mass is in an iron mortar reduced to powder, kneaded into a stiff paste with a weak sal ammoniac solution and smeared into the engraving, after which it is brought to fusion by heating the article in a manner similar as with enamel.

After the work has gradually cooled the niello surface is filed smooth, ground and polished.

This substance, although not so intensely black, resembles black enamel; no such exquisite trouble is necessary and it is of greater durability.

Niello is almost exclusively employed for silverware, and, as previously specified, the design is either engraved or pressed in.

**OXIDIZING THE SILVER.**—The frequently employed and falsely denominated "oxidizing" is performed by introducing the silver or silver-plated articles in a slightly heated bath containing a medium strong solution of potassium sulphide in water and a little spirits of hartshorn, or of very dilute ammonium sulphide. A film of sulphide of silver (not oxide) is thereby formed upon the surface of the article. The gray black color of the coating is intensified by polishing.

[THE END.]

---

## Proceedings of the Horological Club.

---

### A DISTINGUISHED BODY OF WATCH AND CLOCK MAKERS.

---

*One hundred and twenty-first discussion.—Communicated by the Secretary.*

---

[NOTICE.—Correspondents should write all letters intended for the Club separate from any other business matters, and headed "Secretary of the Horological Club." Direct the envelope to D. H. Hopkinson, Esq. Write only on one side of the paper, state the points briefly, mail as early as possible, as it must be received here *not later* than the eighth day of the month, in order to be discussed and reported in the CIRCULAR for the next month.

---

### ABOUT DANGER FROM TELEPHONE WIRES.

*Secretary of Horological Club:*

Will you please inform me if having a line or exchange lines of a Baxter Telephone Company running into a watchmaker's shop would have any effect on watches, that is, would it be liable to magnetize them? Also, is there power enough in it to attract lightning in time of a thunder storm so as to make it dangerous to persons in the room?

E. K. B.

Mr. Electrode replied that any wire leading into a house is liable to conduct lightning or currents of atmospheric electricity during storms. Whether it would be dangerous depends, of course, upon the strength of the current or discharge. Lives have been lost by such means, but not often. The more usual results are the causing of fires or damage to the instruments and contents of the rooms. It is customary in all telegraph offices and in most places having telephonic apparatus, to connect the wires to some sort of "lightning arrester" or device for leading off any excessive currents to the earth, and preventing them doing any damage to the apparatus. It is also well to disconnect the instruments from the line during storms. Before doing this, however, you should consult the superintendent of the line or exchange, as in some systems of telegraphy and telephony such a breaking of the circuit would disarrange the entire system. Any desired information upon such points can always be obtained from the superintendent, and there should be no interference with the line without his knowledge or consent.

As regards a wire magnetizing watches, a single wire carrying a telephonic current would *not* magnetize a watch. It is only where the wire is curled into the form of a ring or coil that it develops magnetism and can magnetize. It then becomes a magnet, temporarily, and is known as a colenoid. If there is a soft iron core within

the coil it is called an electro-magnet. The magnetism disappears when the current ceases. A magnetized piece of hardened steel is a permanent magnet, as is a piece of loadstone. Any form of magnet will magnetize, but a straight wire conducting a current does not magnetize, although it may disturb the running of a watch, especially if the balance or lever of the watch is already magnetized. All wires conducting currents should, therefore, be kept as far as possible from running watches. This is particularly necessary in the case of electric light wires as the currents are often of very high electro-motive force.

Any apparatus or machinery containing magnets should be located as far as possible from the watch rack, and the watch wearer should lay his watch aside when going near them as it may become magnetized at a distance of many feet from the machine. If a watch acts irregularly after such a visit it may be safely considered magnetized, and the workman should first apply the proper tools to determine that point. The most convenient way is to see if the suspected piece of steel (when clean and dry) will lift fine iron filings. The more filings adhere to it, the stronger its magnetism is.

#### HOROLOGICAL SCHOOLS IN SWITZERLAND.

##### *Secretary of Horological Club:*

Can any member of the Club or any of the readers of THE CIRCULAR give any information in regard to the Horological School at Geneva, Switzerland, or any other Horological School in that country? Please give an early reply. C. B.

None of the members had any definite knowledge concerning such schools. Mr. Uhrmacher said that some particulars had been published in THE CIRCULAR from time to time. There is generally some knowledge of the trade required to secure admission, and a prescribed course of instruction to be gone through with during which the student pays for his food and lodging, instruction, use of the tools, etc. Prices, course and other details are different at each place. The best and quickest way is to write direct, stating what you want and what you wish to know. Postage is cheap now-a-days and you can write to several places at small expense. Address "Director of Horological School" at Geneva. There is also a good school under the control of M. Grossmann, at Glashütte, Saxony, (Germany), and at other places. We would be pleased to hear from any of our readers who can give particulars.

#### LUCENE FOR CLEANING WATCHES.

##### *Secretary of Horological Club:*

I have noticed several articles in THE CIRCULAR on *Benzine for Cleaning Watches*. Refined benzine, deodorized, called *Lucene*, is the only article that should be used for cleaning watches. Use the peg freely by dipping in Lucene and reaming holes. Allow every part to remain in Lucene for some time except the balance and spring—say about five minutes for them—and then dip the tip of a fine brush in Lucene and proceed to clean the plates and train. Remove jewels and place them in a cup, also *springs, screws*, etc. Allow *jewels* and *spring* to dry on clean blotting paper or scratch pad paper. Dip the jewels 2 or 3 times and lay on paper as before, and then dip and place jewel between thumb and finger and strike it with a clean, dry, fine brush.

All Lucene comes with the name on the bottle. It can be had in quantity, but be sure you get a good article. I would advise using that which comes in bottles first as a test. Do not use alcohol with prepared chalk, as it is very apt to run into jewels and places where it will do harm. Use clear alcohol after the Lucene has evaporated and draw the brush over very fine chalk.

By cleaning mainspring in Lucene and not wiping, or opening, or spreading the spring you will have fewer springs break than cleaned with alcohol, as alcohol is the cause of more springs breaking than any one thing except spreading and wiping. LUCENE.

#### THE LAW GOVERNING WATCH REPAIRERS.

##### *Secretary of Horological Club:*

Can you give me information on the following points:

1. Is there any law as to the length of time a watchmaker shall keep a repaired watch if not called for, or is it optional with himself?
2. If not called for, is there any prescribed course he must pursue to get his charges out of it?

3. In case they should be stolen from him, is the repairer responsible for watches left with him?

4. How to get possession of a watch loaned to a customer if he does not call for his own left for repairs?

5. Do you know the process in watch factories for cleaning movements and if it is applicable to old as well as new movements? L.

Mr. Clerkenwell thought there was no law as to how long a repairer should keep a watch. As the warrantee began when the watch was ready and would run out in a year afterward, it would appear to be for the customer's interest to call for it soon. But if he had in his pocket a better watch than his own he might prefer to hold on to that. If that belongs to the repairer and was lent to the customer to be kept only till his own was ready, he is bound to return it when he is notified that his own is done. If he refuses to give it up when it is demanded from him he would probably be liable to arrest for stealing it. This, of course, would depend on the laws of each State and the understanding between the parties when he got it. The proper course is to inform him that his watch is ready for him and ask him for yours. If he refuses to give it up you should consult some competent lawyer before taking any further steps. And the same about collecting the charges. It would probably be safe to give notice that if the watch was not called for and charges paid within a reasonable time, say thirty days, you would sell it for the charges. But unless the customer agreed and consented to that, it would be best to consult a lawyer before proceeding to extremities.

As regards responsibilities, it would seem that the repairer ought not to be liable for watches stolen from him, provided he took proper and reasonable care to protect them. But all would depend on what was "proper care." If the watchmaker had an ordinarily good safe in which to put the watches at the proper time, locked the safe properly, guarded his store properly—and in all respects took the same proper care of them as he did of his own property, he probably would not be required to pay for them if the store was broken into and robbed—especially if he lost his own property at the same time. But in matters of law always consult a lawyer. Circumstances, slight in themselves, may alter the whole case. If any of our readers have had occasion to learn the law in such cases by experience, it would confer a favor on many persons if they would give us their experience. Nobody expects to be robbed, but everybody would like to know what their position would be in such a case. To render the statement of any value the circumstances should be fully explained.

The process used in factories for cleaning watch movements would be of little use to ordinary custom repairers, as it relates chiefly to the quick handling of large number of pieces. The best methods for repairers have been given frequently in our Proceedings.

##### *Secretary of Horological Club:*

Is not Mr. Electrode a little off his balance in the answer to my enquiry published in your last issue? I am not satisfied with the answer; evidently he is not conversant with watches or he would not write the editor of *The Journal* up as an ass, for if I mistake not I clipped the article from that western horological journal. Be that as it may, and even at the risk of being put among those familiar animals he is so well acquainted with, I beg leave to differ with him. We know very well that watches are affected by magnetism, also that wearing an electric belt on the person of the watch carrier will cause an accurately regulated watch to "run wild." Conversing with one of the best watchmakers in the city, a person who has charge of the largest repair department, he says: "I know of numerous cases where electric belts have caused great irregularity in the running of watches. Why," said he, "the Rev. ——— has a very fine Swiss watch that I have taken care of for the past ten years. Never had any trouble with it. After I cleaned it the last time I regulated it very close, gave it to the owner; he came in in a few days, the watch was 15 minutes out. I carried it; it ran within one second a day. He tried it again; the result was about the same as before. He came in with a friend who carried a watch running very close. I asked them if they would mind changing watches for a week. They said no. In a few days my Rev. customer came in. His friend's watch had varied about twenty minutes; his watch carried by his friend had varied 10 seconds. I then asked him if

he wore an electric garment of any kind; he said he did. I asked him if he could leave it off for three or four days; he said he would. The result was his watch ran as close as of old."

I have known of many cases where the case springs have been the means of irregular running of watches. One case in particular where a watch carried by a railroad conductor was made to run regularly by substituting composition springs. There are many cases where ladies' watches vary from the attraction of the steel in corsets. There is no delusion about the personal magnetism of persons affecting the running of watches."

If "Mr. Electrode" would take the trouble to interview the watchmakers of New York City he might come to the conclusion that all the "donkeys" are not west of the North River. Or let him interview the editor of THE JEWELERS' CIRCULAR, so ably edited by D. H. Hopkinson, Esq. I have a piece clipped from the New York Tribune. "Decidedly watches are queer things. They possess some unaccountable peculiarities," said D. H. Hopkinson of THE JEWELERS' CIRCULAR, seated in the easy chair of his editorial sanctuary. "For instance, some time about the beginning of last summer when there had been a succession of fine displays of the Aurora Borealis, it was estimated that in a single night in the city of New York the mainsprings of not less than three thousand watches broke. This estimate is based on actual enquiries. *Fine sensitive watches* (note, thou shallow Electrode) *are particularly liable to be affected by electrical atmospheric disturbances.*" \* \* \* "It is a fact," he says, "that since the introduction of the *electric light* a large number of watches, some of them *very fine ones* have become magnetized." \* \* \* How is it Mr. Electrode about "those referring to electricity were sheer nonsense." Where is the ass grazing now? On the western prairies or in sight of the City Hall of New York? But, then, why should I take up the club for the other fellow only for the good of the craft.

Electricity and magnetism are part and parcel of the same substance. The lightning strikes a person that carries a watch, the watch is magnetized. Put the watch on a horseshoe magnet and there is the same result. Expose it to the current of a dynamo machine or to the current transmitted into the *person* and you find it *affects* the watch. I have seen the remedy and it is not a humbug. I saw the same principle applied to the ship compass. I remember seeing a compass placed in an iron pot; before that it was irregular, after that it pointed to the true course. There has been invented in this city an electric shield that truly prevents any magnetism causing irregularity in the watch. Not only that but take a movement that will be so strongly magnetized that it will not make a "tick," put it in one of his shields and it goes off at once on time. That I have seen with *these eyes*. Mr. Electrode may be a fine gentleman, but I would suggest to him that he write a book, "What I do not Know About Electricity." PITMAN.

### Emery and Emery Wheels.

EMERY, emery wheels and emery grinding machines have assumed an important place in the working of metals for the last decade, and with the increasing lapse of time have become almost indispensable to the watchmaker; it may, therefore, be of interest to examine the subject somewhat closer.

With "emery" is understood a derivative of a very noble patriotic family of the mineral kingdom, named "corundum" by mineralogists. Chemically speaking, corundum or emery is nothing else than anhydrous alumina; it is distinguished above all other minerals by its hardness, ranking immediately after the diamond, and is, therefore, excellently suited to wear all other materials.

The raw material "emery" was already known to the ancient Greeks, who made use of it as a grinding and polishing agent. They named it for its source of provenance, the island Naxos or Naxium. During the centuries which separate us from the epoch of Greek culture, it was impossible to find a material which even approximately replaces the emery of Naxos. Its hardness, its sharpness, is unexcelled, and even if several inferior grades could be introduced in market by reason of their cheapness, the genuine Naxos emery assumes its undisputed rank immediately after the diamond. This emery costs at the place where found twice the price of the second grades, which are found in Anatolia and from there shipped to the European and American markets. The company of the Naxos

emery, the "Naxos Union of Frankfurt, a. M.," about ten years ago obtained from the general contractor of the Royal Greek government diggings in the island of Naxos, the monopoly of sale of the genuine Naxos emery. The company receives the raw material in the shape of blocks which are pulverized in their factories. From the coars and finer powder the wheels and stones are then manufactured by the employment of the highest permissible hydraulic pressure according to a partially patented process, and the composition of the wheels is as nearly as possible suited to the very varying purposes of grinding for which they are to serve.

Emery wheels are at present not alone used for grinding and working of objects that are not attacked by the ordinary sand grindstones or files, but they serve for all purposes of grinding without exception, and their application is constantly increasing. An emery wheel manufactured according to scientific principles is in its capacity proportioned to the old-fashioned sandstone as the locomotive is to the old mail coach, and an analysis of the two stones supports this great difference of quality.

The emery wheel consists of the sharp edged crystals of the Naxos emery—a mineral excelled in hardness only by the diamond, while a sand grindstone is made up of round, soft grains of sand, which, beside this, are frequently wanting in the necessary cohesion. Owing to this lack, they often have unduly hard and again soft places at the same time, which causes frequently a great expense of time and labor in dressing together with an unequal and premature wear.

For the above mentioned reasons, therefore, emery grindstones are used for cast and wrought iron, steel, copper, brass, German silver and numerous other metals and minerals which could formerly be reduced only with the file. It is used for grinding and sharpening knives as much as three yards in length, saws of all kinds and all other tools, and these grinding operations are performed in one-half the time formerly used with the old fashioned sand grindstone, and the saving in wages, time and files is so large that numerous industries were forced to adopt the emery wheel if for no other reason than to compete, after one establishment of the kind had introduced them, and by force of the above three items could for a time undersell its competitors.

These emery wheels are furnished in the most different sizes for dry as well as wet grinding.—[*Gewerbebl. f. d. Grossherzogth. Hessen.*]

### Collection of Antique Watches.

ENDEAVORS WERE made throughout Europe for several years past to collect all the old watches. Switzerland contains a highly interesting collection, and the German Museum at Nuremberg is lately making all efforts for the same purpose—from the Nuremberg egg down to the most modern improved marine chronometer. Mr. C. Saunier has tried to stimulate the French watchmakers into a like movement, without great success, however. A French collection should be very interesting, since the country does not alone possess a very ancient watch industry, but also by reason of the latter having stood under the tutelage of the kings and wealthy nobles, who ordered many a watch made according to some fanciful pattern, many of which are still owned by private individuals.

The French watchmakers' guild existed since the 15th century, and obtained its statutes in the year 1483, from Louis XI.; it was for a long time dependent upon the goldsmiths' guild, until on the 8th of May, 1643, the former were empowered to manufacture every kind of watch case, with the single proviso that they should stamp their names upon each case.

The Marquis Turgot possesses a highly interesting collection—among other specimens, also several of the "decimal watches," manufactured during the first revolution, when, according to an order of the Convention, the day was divided into 10 hours, each of which into 100 minutes, this, again, into 100 seconds.

### Method for Improving Depthing without Tight Bouchon.

AS FAR as I know it is customary whenever a depthing is either too deep or too shallow to tightly bush the corresponding hole, after which the depthing is correctly regulated in the depthing tool, and the depthing distance is then with the latter transported upon the plate or bridge.

May I be permitted to specify another method which I have successfully used for some time, in cases when it became necessary to effect only small displacements, and which renders one good services, besides demanding less time than for bushing tightly, a thing which, in our rushing age when time is money, is a thing of some importance.

As is known when bushing a hole, it is necessary to enlarge it. According to the ordinary manipulation of the broach the hole is enlarged all around; a hole, however, may also be broached in such a manner that it is only opened toward a certain side, and upon this is based my method. For this purpose I fasten a strip of brass in the vise, push a suitable broach through the corresponding hole, lay the plate or bridge upon the strip of brass thus that the broach at the place where the hole is not to be enlarged lies flat against it. When I now turn the broach and gently press against the object, I can widen the hole toward any optional side, after which I bush it with a drilled bouchon. If I wish to be very exact I place the depthing correct in the tool, strike the arc as is usual and broach the hole thus that the arc passes exactly through its center, after which I bush in the customary manner. With a little practice this method will be found preferable to the tight bushing; it is only necessary to pay attention to the pressing on of the broach, otherwise the breaking of the latter would make the job rather costly.— [F. P., in *Allg. Journ. d. Uhrm.*

### The Blow-pipe.

THE BLOW-PIPE, together with a few other simple instruments, has been in use for thousands of years; the Rhig-Veda of the Hindoos speaks of it as the earliest utensil known, and in the antique paintings and sculpture representing metal working, the blow-pipe is introduced, and its origin, now lost in the midst of antiquity, must be very ancient. In the paintings of Kourna, Thebes and elsewhere, they are represented, not only in the simplest form known to us, but with bulbs for condensing the moisture from the breath and other improvements which argue their use and gradual perfection anterior to the earliest times of which we have any record or remains. Its use in mineralogy in analyzing and determining the metals in ores is not so ancient and has been accredited to Antony Van Suab (1738), and to Cronstedt, a score of years later, but with doubtful justice. Devices for condensing the moisture from the breath and for the more convenient carriage in the pocket, etc., are about all the improvements that have been made in the blow-pipe proper from the earliest times. In the proper manipulation of this implement considerable skill is requisite in order that a steady stream of air may be given without intermission. To accomplish this, the operator intercepts his tongue between the roof of his mouth and end of his pipe between his lips while taking in a necessary breath, and at the same time forces out with his lips a steady current of air. If the flame produced be irregular and jagged in appearance, it will be found that the muzzle of the pipe is not in the proper shape, which should be round. Should the flame present the appearance of a ring, it indicates that the mouthpiece is too large. Under the proper circumstances the flame is in the form of a neat cone of a beautiful blue color. The heat produced is very intense. To further augment this, it is usual to place the object heated upon a bit of charcoal, when practicable, which reflects the heat thrown against it and also gives out the heat of its own combustion. Various appliances have been invented for increasing its effectiveness, the most notable of which is the oxy-hydrogen blow-pipe, an instrument for the purpose of burning oxygen and hydrogen gases in their equivalent

proportions, so as to get the greatest heat from the combination. Two volumes of hydrogen and one of oxygen form an exceedingly powerful explosive mixture, in consequence of their instantaneous union upon the application of sufficient heat, as the electric spark or a taper, the result being the formation of water. It was, therefore, early known to be dangerous to experiment with the mixed gases. In some instances, when the gases were contained in separate reservoirs and connected by tubes at their extremities they have become mingled in one of the reservoirs in consequence of a backward flow of the mixture, and serious accidents have occurred. The chief uses of the oxy-hydrogen blow-pipe are to fuse metals and to render lime incandescent in the Drummond light.

None of these appliances, however, fully comply with the demands of goldsmiths and metal workers generally, as the flame is not sufficiently under the control of the workman; they will do where a steady flame is required, but when it is now to be flaring, now contracted, they are useless, and until some inventor produces an instrument that combines the intrinsic merits of the original blow-pipe with the advantages offered by the various improvements, we fear that the old instrument will not and cannot be supplanted by any invention up to date.

### Bavarian Gold and Silver Work.

NO COUNTRY in the world was once so celebrated for its gold and silver works as Bavaria, as may be gathered from old writings descriptive of the silver art work which adorned the royal and public buildings in Augsburg, Nuremberg and Munich. So far back as the sixteenth century the Bavarian goldsmiths' work was preferred to that of the Italians, and at the same period the country was famed for its specialty in gold filigree work, then known as "Parisian wirework." After the Thirty Years' War, the technical and artistic skill of the goldsmiths pretty nearly disappeared, and at the present time the operations of the craft are mainly restricted to the putting together and construction of articles the component parts of which are constructed elsewhere. Exceptions must, however, be made in respect to certain manufactories where machinery is employed to turn out work of a more or less artistic character. The galvanic process has almost entirely superseded the older process of fire-gilding introduced into Geneva in 1840 by De la Rive, and generally adopted in the workshops there at that time. Of the 5,615 firms in the German Empire engaged in the gold, silver and jewelry manufacture in 1875, 610, giving employment to 1,223 persons, belonged to Bavaria. Most of the work is done by hand, there being only 3 establishments where machinery is employed, water power in 2, and steam machinery in the remaining one. Very little gold is found in Bavaria, but the sand of certain rivers yield a small quantity by careful washing; the value of the gold so obtained in 1880 amounting to 145 marks against 298 marks in 1879.

[Copyright Secured.]

### Letters to Watchmakers.

[By DR. LEONARD WALDO, Astronomer in charge of the Horological Bureau of the Yale College Observatory.]

VI.

### OBSERVING THE TIME. (Concluded.)

SINCE WRITING the last letter, John Bliss & Co., of New York, have very kindly sent me one of their small jewelers' transits for examination. I find it to be quite well made and adapted to its purpose, especially if sure observations are alone to be taken. It has a clear aperture of a little more than one inch, a focal length of nine inches, it magnifies between nine and ten diameters, is provided with a fairly good level, has its axis bored out and a diagonal reflector inserted in the middle so that a lamp on one side throws its light against the glass reticule on which the five lines are ruled, instead of the older and more easily broken spider lines. I find in using the instrument that the lines need to be a little coarser and blacker if the instrument is to be used for star observations. As at present constructed when the light reflected into the telescope at night is sufficiently bright to see the fine glass lines easily, it is so bright that only stars of the first or second magnitude can be observed. The base of the transit can be easily screwed firmly in place.

I have no intention of entering into the methods of getting time-

ordinarily employed by astronomers and involving both very nicely adjusted instruments and some calculation. The watchmaker who is interested in this work will find all he cares to know in the books I mentioned in my last letter. I want here to point out some of the practical conditions of determining time quickly to a reasonable degree of accuracy, say within one second.

Supposing a transit has been obtained, the first question is how to mount it. A choice of a site must be such that the North star is always visible, *i. e.*, any obstruction to the north ought not to rise above thirty degrees for the southern part of the United States. If a special pier is to be built for a transit instrument, the best way to do is to build it of brick, set it in Portland cement and cap it with a flat stone. The foundation for this pier should go three or four feet into the ground, and it is better to have it rest on sand or dirt than on solid rock. In the latter case every passing wagon transmits its vibrations to the instrument. If the transit is to stay in place, an easily removable box needs to be locked around it. A convenient way of doing this is to build a platform about eight feet square, surrounding the pier but not touching it, and having a tall square wooden box open at the bottom which when erect serves as a protection to pier and instrument, but when the latter is in use the box is laid on one side and becomes a combined seat and table.

A simpler form of pier which answers very well for small instruments consists of four scantlings, each about three or four inches square set in the ground and boxed together at the top. A piece of two inch planking makes a good top. A simpler form still is to fill a barrel with sand and use its top as the resting place of a smooth, flat stone.

In working with a small instrument it is better to stand up than to sit, and the height of the pier should be such that when the telescope points to the zenith the eye is conveniently placed for observing. A box used as a foot stool comes into use for low stars or the meridian mark, which for night use is best made by cutting a small round hole in a brass plate behind which a lamp is placed, and which can be either to the south or north of the transit. If it is within a hundred feet of the transit it can be rendered visible by having a little cap to slip over the transit object glass which has a simple uncorrected lens set in it of about the focal length that the meridian mark is distant from the transit. These long focussed lenses are not easy to get, however, and it is better to take a meridian mark so far distant that it can be seen without disturbing the focus of the transit instrument. Sometimes it is not easy to get a meridian mark north or south of the transit instrument, and in such cases a mirror is sometimes used into which the transit looks and which reflects a distant point in some other direction. The mirror in this case must be very firmly secured as the slightest change in its position is doubled in its effect on the view of the distant meridian mark because of the reflection.

In night observations the management of lights about the instrument is troublesome at first. The ordinary bull's-eye lantern is the best cheap light to be had, and nothing but the very best sperm oil burning through a comparatively loose wick ought to be used. Such conveniences as adjustable stands, so that the clock, note book, circle and transit axis reflector can be easily illuminated; screens for shading the observer when observing faint stars; easily accessible oilers for filling small lamps, etc., will suggest themselves to the watchmaker after a very short experience with observing stars at night. The first thing after the instrument is mounted, leveled and the center of the cross wires has been adjusted so that forming the instrument axis end for end in its Y supports the same object remains bisected, is to bring the transit into the meridian. About the only satisfactory way of doing this is by means of the pole star.

If the local sidereal time is known to within half a minute, all that it is necessary to do is to point the middle wire of the transit on the star when the sidereal time is the same as the star's right ascension. The star is then about a degree and a quarter above the pole of the heavens. Twelve hours from that time it is on the meridian again,

but is a degree and a quarter below the pole. In either case it is on the meridian. Now, the pole star moves so very slowly that in a half minute of time it will only move as much as would be equivalent of two-thirds of a second in the motion of a star at the equator. Supposing the instrument is as near the meridian as this, it will be now a very simple matter to obtain the time from the transit of a single star near the zenith.

Assuming that the instrument is always near the meridian and that it is kept leveled, all that it is necessary to do to obtain the time to quite within a second, even with very small instruments, is to observe a single star within three or four degrees of the zenith.

This is a much more elegant and accurate method than observing the sun, and I am quite sure that when the watchmaker has overcome the first difficulties of observing at night, that he will prefer this method to any other. Of course, it is necessary that the "American Ephemeris and Nautical Almanac," of which I have already spoken, should be at hand, and the watchmaker will quickly see how to get the sidereal time of any star's transit from the pages marked "Fixed Stars" which follow the list of "Fixed Stars." The places of these stars are given for every ten days and it will be quite sufficient to take a tenth of the difference between the changes for ten days as the change for one day. This will explain itself when the intending observer comes to look at his almanac.

It is a great convenience to have a list of stars to be used in this method already made up. I have, therefore, taken the stars between 34° and 46° north declination which are given in the almanac for 1877, and made the following list of them in which there is a blank column for "circle setting," to be filled up by the observer who puts here the reading of the circle on his instrument to find the star.

List of Zenith Stars for Time Observations.

| Star's Name.             | Magni-<br>tude. | Right<br>Ascension. |      | Decli-<br>nation. | Circle<br>Setting. |
|--------------------------|-----------------|---------------------|------|-------------------|--------------------|
|                          |                 | H.                  | M.   | N.                |                    |
| 22 Andromedae.....       | 5.3             | 0                   | 4.4  | 45° 27'           |                    |
| " ".....                 | 4.3             | 0                   | 12.4 | 36 10             |                    |
| " ".....                 | 4.0             | 0                   | 50.5 | 37 53             |                    |
| β ".....                 | 2.3             | 1                   | 3.4  | 35 41             |                    |
| " ".....                 | 4.0             | 1                   | 30.2 | 40 50             |                    |
| γ ".....                 | 2.3             | 1                   | 57.0 | 41 47             |                    |
| β Trianguli.....         | 3.0             | 2                   | 2.8  | 34 27             |                    |
| β Persei.....            | 2.7             | 3                   | 0.8  | 40 31             |                    |
| ε Persei.....            | 3.3             | 3                   | 50.2 | 39 41             |                    |
| μ Persei.....            | 6.0             | 4                   | 25.5 | 42 49             |                    |
| ζ Aurigae.....           | 4.0             | 4                   | 54.6 | 40 55             |                    |
| α Aurigae.....           | 1.0             | 5                   | 8.3  | 45 53             |                    |
| ν ".....                 | 4.0             | 5                   | 43.6 | 39 7              |                    |
| β ".....                 | 2.0             | 5                   | 51.2 | 44 56             |                    |
| θ ".....                 | 3.0             | 5                   | 52.0 | 37 12             |                    |
| ψ5 ".....                | 5.7             | 6                   | 58.6 | 43 11             |                    |
| θ Geminorum.....         | 3.3             | 6                   | 45.3 | 34 6              |                    |
| 63 Aurigae.....          | 5.0             | 7                   | 3.9  | 39 30             |                    |
| 26 Lynx.....             | 6.0             | 7                   | 46.5 | 47 51             |                    |
| α Lyncis.....            | 3.3             | 9                   | 14.2 | 34 52             |                    |
| 10 Leo Minoris.....      | 4.7             | 9                   | 27.3 | 36 54             |                    |
| 19 Leo Minoris.....      | 5.3             | 9                   | 50.8 | 41 36             |                    |
| λ Ursa Majoris.....      | 3.3             | 10                  | 10.3 | 43 29             |                    |
| 46 Leo Minoris.....      | 4.0             | 10                  | 47.0 | 34 49             |                    |
| ψ Ursa Majoris.....      | 3.3             | 11                  | 3.3  | 45 7              |                    |
| 2 Canum Venaticorum..... | 5.3             | 12                  | 10.5 | 41 17             |                    |
| β Canum Venaticorum..... | 4.3             | 12                  | 28.4 | 41 58             |                    |
| α ".....                 | 2.7             | 12                  | 50.8 | 38 56             |                    |
| 20 ".....                | 4.7             | 13                  | 12.5 | 41 10             |                    |
| B. A. C. 4536.....       | 5.0             | 13                  | 29.8 | 37 46             |                    |
| 33 Bootis.....           | 5.3             | 14                  | 34.6 | 44 54             |                    |
| β Bootis.....            | 3.0             | 14                  | 57.7 | 40 50             |                    |
| μ Bootis.....            | 4.0             | 15                  | 20.2 | 37 46             |                    |
| φ Herculis.....          | 4.0             | 16                  | 5.2  | 45 14             |                    |
| σ Coronae Borealis.....  | 5.7             | 16                  | 10.5 | 34 9              |                    |
| η Herculis.....          | 3.3             | 16                  | 39.0 | 39 8              |                    |
| π Herculis.....          | 3.0             | 17                  | 11.1 | 36 56             |                    |
| θ Herculis.....          | 4.0             | 17                  | 52.4 | 37 16             |                    |
| ε Lyrae.....             | 5.0             | 19                  | 3.3  | 35 55             |                    |
| θ Lyrae.....             | 4.3             | 19                  | 12.5 | 37 56             |                    |
| δ Cygni.....             | 2.7             | 19                  | 41.4 | 44 51             |                    |
| α Cygni.....             | 1.7             | 20                  | 37.6 | 44 53             |                    |
| ν Cygni.....             | 4.0             | 20                  | 53.0 | 40 44             |                    |
| 61' Cygni.....           | 5.0             | 21                  | 1.8  | 38 12             |                    |
| τ Cygni.....             | 4.0             | 21                  | 10.3 | 37 34             |                    |
| 74 Cygni.....            | 5.0             | 21                  | 32.4 | 39 54             |                    |
| 10 Lacertae.....         | 5.0             | 22                  | 34.2 | 38 28             |                    |
| α Andromedae.....        | 3.7             | 22                  | 56.7 | 41 43             |                    |
| λ ".....                 | 4.0             | 23                  | 32.0 | 45 51             |                    |

## Foreign Gossip.

IMPORT OF SWISS WATCHES DURING 1883.—The *Schweizerische Uhrmacher Zeitung* gives a tabular statement of the watches exported from Switzerland to the United States in 1883, footing up a total of francs 9,208,033 94 centimes, and divers other items of francs 127,159.10 centimes.

BIDS OPEN FOR RUBY MINES.—The ruby mines of Burmah, it seems, are open for tenders, as, according to the Rangoon papers, some French capitalists have offered the large sum of 300,000 rupees (1 rupee=about 54 cents) per annum for permission to work them; the Burmese Government, however, is said to have declined the offer, demanding an annual rent of 500,000 rupees for the monopoly.

DEATH OF A SCIENTIST.—The famous Cambridge (England), mathematician, Dr. Isaac Todhunter, M. A., T. R. S., died in the beginning of March. He was the son of a Dissenting minister at Rye, and after passing some years of his life as an usher in a school, he studied at St. John's College, Cambridge. He is the author of many educational series, and we suppose that his name is familiar in all countries and schools wherever the English language is spoken.

SAUCERS FOR GOBLETS.—A question was asked in the Berlin Art Society whether saucers for goblets could not be introduced; disagreeable exchanges of goblets frequently take place when gentlemen walk around and converse while drinking their after dinner wine. These saucers might be painted or otherwise decorated in such a manner that each gentleman would readily recognize his own, and there is no doubt but that they would soon be introduced into general usage.

TRAVELERS' TALES.—The inhabitants of Chiloë (southwestern coast of America), use a highly peculiar barometer, which has been named barometro Aurocans by the discoverer, the captain of an Italian corvette. This weather guage was recently described in the Linnean Society of New South Wales. It is the shell of a crawfish, an *Anomura*, probably of the species *Lithodes*. This shell is extraordinarily sensitive against changes of temperature; being almost white in dry weather, it becomes covered with small red spots on the approach of moist weather, and as soon as the rainy season occurs it becomes entirely red.

TOURMALINE.—This gem was named for Turamali, in Cingalese, where it is found, and also at Paris, Maine, and a few other spots; and when it first happened to be brought to Holland in 1702, it excited attention by the electric property that caused it to be called the ash burner. Of value, as it undoubtedly is, it is still found above the surface of the ground, like a pebble or an ancient chipped flint, at the places where found. Tradition says that a child, running after a naturalist who was crossing a field, showed him one she had chanced to pick up as long as his fingers and twice the thickness, which, with the proverbial disregard of science for anything but science, he bought for one dollar, although its actual value would have been a comfortable dowry for the little girl.

INTERCEPTING TELEGRAMS.—The *Invalide Russe* reports the invention by a Russian officer of sappers, Lieutenant Krudinow, of a portable apparatus for intercepting telegraphic and telephonic messages in war times. The apparatus is a small square box weighing a little over 4½ pounds. It contains mechanism for transcribing a telegram or making a telephonic message audible. At the top of the box is a small battery for returning false charges to the enemy. For sending ordinary telegrams the apparatus should be in the hands of a telegraphist. It is enough to send a man within the enemy's lines who would cut the telegraph wires and connect them with the apparatus, setting the mechanism going which unrolls the strip of paper. The telegraph then automatically transcribes the message on the paper which need only be sent to the nearest staff office to be decyphered. The apparatus has already been tried and found practicable.

DIALS.—The examiner of application for patents at Washington has rejected nearly all those which, since the adoption of the new "standard" time, have been presented with the idea of securing a monopoly of watch and clock dials with figures arranged to show the twenty-four hours in a convenient way. It appears that an old record exists in which it is stated that Prince Soltykoff possessed a watch made in 1547, which contained the twenty-four hours arranged in concentric circles.

A NEW DODGE.—A new device is resorted to by sharpers on the continent. A boy or a woman belonging to the "poor but honest" class, if possible, hobbles on crutches to the house door steps, rests for a few minutes and is so lucky as to find a diamond ring. She rings the door-bell, states her story, and, of course, the ring belongs to the house and was accidentally swept out by "that careless housemaid." The finder receives a reward of a few shillings for her honesty and hobbles off. Grand tableau when the diamond is found to be glass and the gold brass.

ASCERTAINING THE TIME IN CHINA.—The *Journal Suisse d'Horlogerie* says that when a Chinese farmer who cannot afford the luxury of a gold watch or a French ormulu clock wishes to ascertain the time of day, he simply gazes into the eye of his cat. He takes the animal, looks at its pupils and ascertains his chronometer time, although not at night, at least from early morning until obscurity, from the degree of their expansion. Every one knows that the pupil of the feline species contracts during the day and expands in obscurity; but it appears that these two operations progress so regularly during the hours of the day that an expert can ascertain the hour from them. The pupil is oval in the morning, having been round during the entire night; it decreases in size from morning till noon, at which time it is a straight line and gradually becomes oval again from noon till night.

IGNORING HOME INSTITUTIONS.—Our Swiss exchanges are most energetically "kicking" against the insult conferred on their very skillful home artists, as the Swiss government has not alone ordered its bank notes to be engraved and printed in England, but also the engraving of the steel matrixes for a new series of 20-franc pieces to be done outside of the country. According to several croaking journals of Switzerland, the *Imparcial* among them, THE JEWELERS' CIRCULAR is constantly belittling Swiss work and artisanship, and we therefore desire to call their very special attention to these our remarks, when we say it is our undivided opinion that there are but few countries which can seriously compete with Switzerland in this or any other branch of engraving, watchmaking, etc. Of course, we always except the United States; our superior capabilities being too well known to be placed for a moment in a doubtful position. There!

METRIC SYSTEM.—There is every probability that the metric system will not be introduced into England and the United States. Friends of the system have been agitating the subject in England for years without making any progress for the obvious reason that the English are too conservative a nation to lightly do away with a system that bears to them the imprint of a thousand years, and societies are being organized all over the island for retaining the old system. At a meeting of a society of this kind organized here in New York, a speaker quoted figures to prove that nearly one-half of the total wealth of the world was possessed by nations using the weights and measures in use among us. He also went to prove "that nations using our system carry half the tonnage of the world; that two-thirds of the commerce of the world is in their hands, and their trade is increasing in a ratio three times greater than that of any other nation." But whether he wished to draw the inference that this success was due to the fact of our using "pounds, ounces and grains" we could not understand. At any rate, the duodecimal system will always be preferred by uneducated people, because 12 and its half and quarter are full figures. 12, 6, 3, while the decimal at once almost enters into fractions; 10, 5, 2½, etc., or presupposes an education in decimals 1.0, 0.5, 0.01, etc.



## Workshop Notes.

**CARBOLIC ACID ON METAL CUTTING TOOLS.**—Carbolic acid is recommended for moistening the tools with which metals are worked. The efficiency of the grindstone is even said to be increased by the use of the acid. The dark and impure acid can be used for this purpose.

**GOLD-COLORED VARNISH.**—For preparing a gold-colored varnish pulverize 1 drachm of saffron and one-half a drachm of dragon's blood, and put them into 1 pint of spirits of wine. Add 2 ounces of gum shellac and 2 drachms of Soccotrine aloes. Dissolve the whole by gentle heat. Yellow painted work varnished with this mixture will appear almost equal to gold.

**RE-SHARPENING OLD FILES.**—First clean well with scratch brush, then with benzine; see that the file is thoroughly clean, then place it in a bath of the following solution: One part acid, five parts sulphuric acid. Let it remain for three or four days or until the edges of the file are fully restored. Wash thoroughly with water to remove the acid, when the file will cut as good as new.

**RE-LACQUERING BRASS ORNAMENTS.**—The following is a good method for re-lacquering brass ornaments: Wash the objects in a hot solution of potash (made pretty strong). When the lacquer is removed the articles should be washed and dried, then re-polished before lacquering; clean well and wipe with lime. Then, when free from rust or dirt, warm on a stove until just hot enough to hold, then lacquer with either brush or piece of raw cotton.

**RUSSIAN NIELLO.**—The composition of the Russian tula or niello silver has hitherto been kept secret to the *Berliner Tageblatt*. The firm of F. Zacher & Co., in Berlin, have discovered the method of manufacture and have made it in large quantities. It consists of nine parts silver, one part copper, one part lead, and one part bismuth, which are melted together and saturated with sulphur. This mixture produces the gorgeous blue which has often been erroneously spoken of as steel blue.

**BRITTLE GOLD.**—The goldsmith is often puzzled to soften gold so that it can be forged out thin without cracking and breaking. Some gold can be forged out easily while others is very hard and brittle, because the impurities or alloys, such as a little lead or zinc, tend to make it so. Melting over a stone coal fire would do the same. Gold should be melted over charcoal or coke, and, if of low grade, should not be exposed to the heat too long. If it has no "grain" melt again. If it does not take grain then melt again and add a little saltpeter, and, a little later, some borax. For ordinary meltings fuse with borax, stir well and add a little sal ammoniac just before pouring it out. In forging gold it must be annealed as often as it begins to get hard and brittle. Low grade gold needs annealing oftener than finer gold. Heat red hot and let cool without tempering.

**AN INDIAN BRONZE.**—The Hindoos possess a remarkable ability for making alloys of iron, copper, zinc and tin. Let us cite the Biddery; the alloy is called after the city where it is most prepared and found in all its purity. The eminent qualities of this alloy are that it is non-oxidizable in and even if the latter is charged with humidity, under the burning tropical sun. It is perfectly malleable and does not crack except, perhaps, by violent blows. Objects of art manufactured from this alloy are colored black by plunging them into a single solution of saltpeter and sal ammonia or sea salt and blue vitrol. One receipt for preparing the alloy reads as follows: 16 parts copper, 4 lead and 2 tin, melted together. Zinc is combined with this mixture in a proportion of 3 to 10. Doctor Hamilton gives another formula: Zinc, 126 parts; copper, 460; lead, 414; no tin. These ingredients are finely crushed and inclosed in a crucible with a mixture of beeswax and resin, to prevent calcination and to simply effect fusion. The fusing alloy is run into an earthen mold and shaped into the desired form. To give it a black color, a solution of sulphate of copper is used.

**MENDING VULCANITE CHAIRS.**—Watchmakers are often asked to mend the broken parts of vulcanite chairs. If an attempt is made to open them cold the links will, in nine cases out of ten, snap, especially stout ones; and if they do not break the ends spring open and will not again close. Heating by candle or fire will burn them, but if held over the chimney of a kerosene lamp, they will in a few seconds become so soft that you might bend them straight and shut them up again or close them as when new without injury to shape or polish. Horn or tortoise shell may be treated in the same manner.

**GALVANIC GOLD BATH.**—Mr. Rad, in *Le Monde de la Science*, gives the composition of a bath to be used at temperatures from 50° to 80° C. (122° to 176° F.) It consists of crystalline phosphate of soda, 60 parts; bi-sulphate of soda, 10 parts; cyanide of sodium, 1 part; chloride of gold, 2½ parts; distilled water, 1,000 parts. In order to prepare the bath the water is divided into three portions of 700, 150 and 150 respectively. The phosphate of soda is dissolved in the first lot, the chloride of gold in the second and the other ingredients in the third. The two first portions are gradually mixed together and the third is then slowly added. A platinum plate is used as anode.

**ACCIDENTS IN SMELTING.**—Most jewelers, at some time or other of their experience, have met with accidents in the smelting and pouring of their alloys. Such, for instance, as a pot cracking, the spilling or the upsetting of a portion of the metal from the crucible into the fire. The following mode of recovery of lost metal we have found the best and most practical in the workshop with the ordinary appliances usually at the command of jewelers and gold workers. Collect the whole of the burnt coke, ashes and other refuse used in the smelting operation, and first of all wash it several times with water to remove the dust and other extraneous matter, the sediment left behind is then well dried and pounded as fine as possible in a cast iron mortar; it is afterward put through a sieve as fine as is convenient to prevent the small particles of gold from going through the meshes with the powdered dust. The gold is now picked at this stage from the refuse in the sieve, and if there be any solid particles of refuse still unpounded it is put through the process again. It is very seldom that the whole of the gold can be collected when once spilled into the fire, but the larger portion of it can be recovered by these means. The other goes into the sweep to be treated by the refiner.

**TO ENHANCE THE APPEARANCE OF BRASS.**—The process for imparting to brass a handsome gold yellow color with either high luster or mat, is principally based upon the use of various pickles. The articles to be treated must previously be exposed to a red glow-heat and then carefully cleaned, which is best done in feeble hydrochloric water (about 1 part acid to 10 parts water). Next follows the first pickling in a wooden, lead-lined receptacle, which contains only a feebly effective pickle of nitric acid. When all spots have disappeared and all articles are of a uniform color, they are rinsed in clear water and preserved in dry sawdust for the next operation. If a gold yellow mat is to be produced, the pieces are entered with the adhering sawdust in a second stronger bath (1 part water to 2 parts nitric acid), in which they are left for a few minutes, until the at first effervescing fluid has calmed down and the froth upon the pieces has subsided again. When the pieces have assumed a uniform mat color they are immersed in concentrated muriatic acid, and at once rinsed in clear fresh water which must be renewed frequently. In order to be very certain they also can be dipped in a warm alkaline lye. After the acid has been thoroughly expelled, the articles are poured over with a boiling solution of 1 part tartaric acid in 30 parts water. They have now assumed a very handsome gold yellow color, and are dried in sawdust contained in a heated iron pan. The adhering sawdust is easily shaken off by placing the articles in a bag. They are next protected against tarnishing by being covered with a colored shellac varnish.

## Trade Gossip.

The firm of A. S. Herzog & Co. will be known hereafter as Herzog Bros.

R. H. Ramsgate has removed from No. 4 Liberty Place to No. 16 Maiden Lane.

G. F. Veith, of Oppenheimer Bros. & Veith, sailed for Europe in the *Ems* June 18.

Martin Marcus, representing I. Emrich, left for Europe June 4 on the *Elbe*, in the interests of the firm.

E. T. Franklin & Co. announce an extensive line of embossed inlaid gold center goods for the fall trade.

Geo. W. Ludwig & Co., of Chambersburg, Pa., have an attractive store and carry a large line of desirable goods.

L. L. Fischer, of W. F. Fischer & Bro., of Chattanooga, recently sailed for Europe, for a three months' pleasure trip.

Ellison & Vester, patentees of a novelty in bracelets, have issued a circular warning the trade against certain infringers of their patents.

C. A. Boynton, for many years with Bryant & Bentley, has left their employ and made an engagement with W. H. Payne & Co. to travel for them.

John Young's jewelry store at Tiffin, Ohio, was recently entered by burglars and the entire establishment cleaned out. Goods to the amount of \$3,800 were taken.

The wholesale jewelers of Chicago gave their employees an excursion recently to Highland Park. Otto Young and his corps of assistants made the affair an entire success.

Heeren Bros. & Co., of Pittsburgh, have just issued a voluminous illustrated catalogue of clocks, watches, bronzes, etc. They are general dealers and carry a large and varied stock.

W. E. White & Co. have introduced many new goods for the fall trade, and offer desirable novelties in lace pins, chain bracelets with gold edges, band and bangle bracelets, etc.

R. Henrich, whose "Acme" patent interchangeable seal ring for gentlemen, has recently brought out a similar ring for ladies, which will, no doubt, prove fully as popular as the gentleman's.

Fox, Bros. & Co., of Cincinnati, will carry this season a very large line of diamond goods specially imported by them. One member of the firm is now in Europe for the purpose of keeping the house supplied with attractive and desirable goods.

The Northwestern Watch Case Company, of Rockford, Ill., having been very successful in manufacturing their climax reversible case in silver, have commenced the production of the same in gold. These are also giving satisfaction to the trade.

G. K. Lansing, of the Astor House, so favorably known to jewelers who have received many courtesies at his hands, has leased the Brighton Beach Hotel, at Coney Island, where he will be happy to see his old friends and as many new ones as choose to call.

At Bingera, New South Wales, the discovery of a new diamond field has been reported, which promises to rival the Kimberley diamond deposits of South Africa. A considerable number of fine diamonds have been discovered within the last few months.

R. & L. Friedlander, dealers in watch materials, tools, optical goods, rolled and plated jewelry, etc., have an extensive assortment of goods in their line. They have issued a descriptive catalogue which will be found full of information and exceedingly useful.

Reed & Barton have removed from 686 Broadway to 37 Union Square, where, in addition to an unusually varied line of fine table ware, they offer many novelties in gold, oxidized silver, inlaid and appliqué work. Their new quarters are commodious, light, well ventilated and elegantly fitted up.

The death of Charles Michellier, business manager and buyer for the Paris house of S. Dessau, is announced, at the age of thirty-two years. The deceased leaves a widow and two children besides numerous friends, to mourn his loss. He was a man of sterling qualities and unblemished character.

Sidewalk vendors of cheap jewelry are so thick as to become a nuisance. It is surprising that in a civilized city like New York the police will permit the public thoroughfares to be occupied by peripatetic peddlers of almost everything that is salable, from stale fruit to paste diamonds. They are a public nuisance and should be squelched.

The Republicans have nominated their candidates and the Democrats are about to do so. This is the harvest time for the badge men, and good metallic portraits of the candidates will appear on every street corner, and customers can be accommodated in any style according to their political convictions.

W. H. Payne, for many years with the Fahys Watch Case Company, and Fred. D. Steck, formerly traveler for J. T. Scott & Co., have formed a partnership and will engage in the wholesale jewelry business under the firm name of W. H. Payne & Co. Their place of business is 191 Broadway corner of Dey street.

R. Ferris, a well-known jeweler of this city, died suddenly at his residence recently, of heart disease. The deceased had been in business in one store for over thirty years. Mr. Ferris was an excellent workman and a business man of strict integrity, who was greatly respected by all who knew him. He was in the 69th year of his age.

The store of Rice & Fellows, of Lawrence, Mass., was recently entered by burglars and robbed of rings, chains, gold pens, pencils, etc., to the amount of \$2,000. The thieves entered by the cellar and forcing a trap door in the floor of the store. The robbery is believed to have been done by a novice, as the most valuable portion of the stock of the firm was unmolested.

The President of the United States has appointed President Barnard, of Columbia College, and Commander W. T. Sampson, executive officer of the Naval Observatory, delegates to represent the United States in the international conference called to assemble October 1, at Washington, to decide upon a common prime meridian as a zero of longitude and standard for the regulation of time for all nations.

At the meeting of the New York Academy of Sciences, May 19th, Mr. G. F. Kunz exhibited a yellowish green cut gem of fluorite chlorophane from Hunter Co., Va., and remarked that although too soft for gem purposes, this stone was possibly the first gem cut that phosphoresced without any great heating. The gem was passed around in a vial of warm water, and in the dark showed a very plain pale green light.

The Jewelers' Safety Fund Society was organized June 19th, 1884, under a charter granted by the Legislature of the State of New York, heretofore printed in THE CIRCULAR. The following officers were elected: President, Henry Hayes; Vice-President, Samuel W. Saxton; Secretary and Treasurer, Ira Goddard. Executive Committee, Enos Richardson, Chas. G. Lewis, Wm. R. Alling, Sam'l C. Scott, Fred'k S. Douglas.

Jeanne Bros., who are the patentees of a new ear wire have issued a circular warning the trade against infringements. Jeanne Bros. sold the right to manufacture to several firms, but some of the eastern manufacturers do not think it worth while to pay for the right, and so have gone to manufacturing without permission. Jeanne Bros. propose to protect their licensees and will prosecute the pirates who are stealing their invention.

We have heretofore noted the fact that an international exhibition of gold and silversmiths' work, jewelry, bronzes, etc., is to be held at Neuremberg, from June 15 to September, 1885, under the auspices of the King of Bavaria. William Bardel, of the firm of Heller & Bardel, has been appointed Commissioner for the United States to interest American exhibitors in this exhibition. Any communications addressed to him will receive prompt attention.

At the annual meeting of the Wisconsin Retail Dealers' Protective Association, held at Madison, May 7, the following named gentlemen were elected officers for the ensuing year:—President, C. A. Estberg, Waukesha; 1st Vice President, F. Foote, Lake Mills; 2d Vice-President, G. Scherringer, Fond du Lac; Secretary and Treasurer, W. H. Thorp, Beaver Dam; Executive Committee, A. L. Howard, Beloit; E. P. Copp, Madison; O. R. Ryan, Reedsburg.

We direct attention to the illuminated advertisement accompanying this issue of THE CIRCULAR, of Howard & Son, manufacturers of the celebrated American Lever Button. This is a live, wide awake firm, that is constantly introducing new goods to the trade. Few new devices for the comfort and convenience of the public have been brought forward that have been more acceptable or more completely filled a "long felt want" than the adjustable sleeve buttons. So great is the demand for these that it has built up a new industry, in which several firms are engaged, giving employment to a large number of men and employing a large amount of capital. Among the various adjustable buttons in the market, none have achieved a greater popularity than those manufactured by the above-named firm.

The E. Howard Watch and Clock Company recently made for Leyson & Turck, of Butte City, an elaborate tower clock, to be placed in the new court house at that city. It was formally dedicated by the city authorities with proper ceremonies, much speech-making, and many compliments for the enterprising local dealers and manufacturers of the clock. Butte City is now all right, and can be depended upon to keep time with the tramp of progressive civilization.

Joseph Fahys & Co. have secured patents for a new screw dust proof watch case, which is applicable to either hunting or open face watches. They have also arranged with Robbins & Appleton to use so much of the patent owned by them, issued to E. C. Fitch, as is necessary to enable them to make these new cases without being called to account for infringements of the Fitch patent. The screw case is claimed to give absolute protection to the movement from dust and moisture.

Fowler Brothers, of Providence, who are the original and only patentees of English crape jewelry, have recently received a re-issue of their patent, and also another patent which extends the application of the original idea. This style of jewelry became very popular last year, and, as a consequence, was immediately infringed upon by other manufacturers. Fowler Bros. are now in a position to prosecute these infringers, and they issued a circular to the trade stating that they will do so immediately. It should be understood that dealers who sell pirated articles are equally liable with the manufacturers, and it behooves them to know what goods they are selling.

This is the season of catalogues, and manufacturers and jobbers are sending them out in quantities in anticipation of a lively fall trade. This is all right, and is a benefit to the retail trade provided it is done with proper precautions. We are in receipt of many complaints from dealers, who assert that large numbers of catalogues, with price lists, are sent out in unsealed envelopes, so that anyone into whose hands they may fall has a "dead give away" on the retailers. They also complain that many of these are sent to outsiders, and can be found in the hands of furnishing goods dealers, druggists, hardware merchants, etc., who are in the habit of selling jewelry. This is a most pernicious practice, destroying the trade of the retail dealers, and must inevitably react upon those who indulge in it. Dealers cannot be expected to see their trade stolen from them by the jobbers without a protest, and that protest will ultimately take a form that will command attention.

A crusade against piano-playing has begun in Berlin. The promoters of the crusade have circulated petitions for signature in all the residence portions of the city, and the petitions, which have a very large number of signers, have now been presented to the municipal and police authorities. They set forth that the constant and monotonous practicing of scales and exercises by piano pupils has become an intolerable nuisance, causing much suffering to invalids, aggravating all forms of nervous diseases and depreciating the value of real estate. They therefore claim that it is a proper subject for police regulation, and pray that a municipal ordinance be enacted restricting the time of piano playing and practicing to the hours between 11 A. M. and 12 noon, and between 8 and 11 P. M. In this country the love for instrumental music is constantly on the increase, and the demand for musical instruments of all kinds, from the squeaky accordion to a grand piano, was never so great as at present. Dealers who wish to diversify their stocks can scarcely do better than to add a line of musical instruments.

On June 13, there was held at Detroit, the annual convention of the Travelers' Protective Association, and business of importance to all travelers was transacted. The purpose of this organization is to make traveling easier, better and more economical for that large and important class of the community known as commercial travelers, whose business requires them to be "on the road" most of the time. From reports submitted to the convention, we learn that the association has a permanent committee on railroad policy, whose chairman reported negotiations with the railroads which he thought would result in travelers being able to obtain at reduced rates 5,000 mile tickets that would be good on all roads from Maine to California, until exhausted. Another committee reported the result of a conference with various senators relative to doing away with the licenses required for travelers. Other business of importance to traveling men was transacted. The association, now in its second year, numbers over 1,600, and efforts are being made to increase it to 5,000 or 10,000, in order that it may be more influential in securing the rights and protecting the interests of the class it represents. The jewelry trade would undoubtedly find itself benefitted by encouraging its travelers to become members.

A circular is circulating in the trade complaining of the methods adopted by manufacturers to dispose of their goods and calling upon jobbers to form protective unions in every city. The principal complaint is, that manufacturers, after selling to jobbers, cultivate the retail trade and thus fill the demand that the jobbers relied upon to dispose of their goods. This matter has been very thoroughly ventilated in THE CIRCULAR on frequent occasions. The grievance is undoubtedly a most serious one, but we do not believe it can be remedied by anonymous circulars. If prominent jobbers will identify themselves with a movement to secure reform in this matter some good might be done, but few persons will pay attention to an unsigned circular.

An individual calling himself C. B. Thompson, has been trying recently to swindle some members of the trade. His plan is to visit a store, make some purchases and pay cash, giving notice that on his arrival home he will probably order more goods. In a few days he sends an order, and if it is filled, that is the last heard of Thompson (with a "p") or the goods. Some years ago a person giving precisely the same name contrived to get some goods from the Howard Watch Company by precisely the same trick. A member of the company followed up the matter and finally had an interview with the individual. After the interview the alleged Thompson had occasion for the services of a dentist to replace two teeth that had been knocked out in the first round of the interview.

It is quite common to see an advertisement in a certain daily paper of some "lady" who wishes to borrow a few hundred dollars for a short time, for the use of which she will give a liberal bonus and deposit her diamonds as collateral. A case of this kind came up in the police court recently. A gentleman responded to such an advertisement, met the "lady" who stated that she had pawned her diamonds worth \$400 for \$100 but wanted \$300 more, for which she would "hypothecate" the pawn ticket and pay a bonus of \$80. The gentleman advanced the money, but when he went for the diamonds found that the \$100 for which they had been pawned represented their full value. The woman was arrested and required to give bail to answer. Greenhorns looking for big profits and "soft snaps" are very likely to be victimized, and if they succeed in "getting their bait back" may consider themselves fortunate.

Readers of THE CIRCULAR will remember the case of S. Rothschild, of Memphis, who was convicted of fraud in connection with his failure and sentenced to three years' imprisonment. He appealed to the Supreme Court which has sustained the judgment of the Criminal Court. It having come to the knowledge of the creditors who had been defrauded by Mr. Rothschild that a petition was being circulated asking the Governor to pardon him, a meeting was held in this city whereat a letter addressed to the Governor, protesting the pardoning of Mr. Rothschild, received the approval of a majority of all the creditors in numbers and amount involved. This letter has been sent to the Governor, and will, no doubt, influence his decision. Mr. Rothschild's offence was a most flagrant one and the sentiment of the trade is that an example should be made of him. Proceedings are pending to trace the goods that he had transferred to others before the failure. Since the above was in type we learn the Governor has granted Rothschild's pardon.

Charles A. Kortenhaus's action against the American Watch Company, at Waltham, Mass., to recover royalties on an improvement in stem-winding watches that he made, and which, he averred, the defendants have put to use, was non-suited last month by Judge Mitchell. Kortenhaus swore that he had submitted his invention to the company's inspection with a view of selling it. The company refused to purchase. Kortenhaus discovered afterward, he swore, that the company had adopted the improvement. He had made the fatal mistake of not having his improvement patented. The court, in dismissing his action, ruled that there was no right of property in an idea as an idea, and that it could only be made property by letters patent. The improvement is said to be so valuable that if Kortenhaus had won his suit his fortune would have been secured. The company's defense to his claim was that at the time the complainant submitted his idea to them they had already adopted substantially the same thing, and that on receiving his communication sent to him a perfected movement made in accordance with the idea he had conceived. It seemed to be a case of a simultaneous discovery by two persons of the same thing. Fortunately for the American Watch Company, it was able to show that it had made practical use of the idea before receiving any communication from the plaintiff or even being aware of his existence.

We would call attention to the advertisement of the Mutual Reserve Fund Life Association that appears on another page. This company is conducted on the assessment plan, similar to the Jewelers' League, the members paying their assessments as death claims arise. There are many members of the League who would like more insurance than they can obtain in that society, and there are others in the trade who are not in the League who need life insurance. The Mutual Reserve advertises insurance at much less than the rates of the regular companies, and announces a liberal surplus fund as a guarantee of its contracts.

A clever swindler has been victimizing the trade in St. Paul by the old confidence game, culminating in bogus checks. He represented himself to be a member of a well-known firm of iron and brass founders at La Crosse, Wis. He called on different members of the St. Paul trade and expressed a desire to purchase diamonds and jewelry, requesting that his selections be set aside for a day or two. In a few days came letters written on elegant lithographed letter heads of the La Crosse firm announcing that he would call for the goods on a certain day. At the appointed time he came and paid for the goods with lithographed checks bearing the name of the firm. The checks were always for a little more than the goods amounted to, so that the fellow not only got the goods but a small sum in cash in exchange for the checks that were found to be worthless. The dealers were victimized to the extent of several thousand dollars, all because the swindler had such a respectable appearance and was so smooth and affable in his manners. There are qualifications and characteristics that the most adroit knaves seek to cultivate. A good rule to adopt with strangers is "spot cash" or a certified check.

A young man with a large magnet was at work along the cross ties of the Sixth avenue elevated railway recently. Once in awhile he carefully brushed off the magnet and secured the particles attached. Then he went down beneath the railway and dragged the magnet in the gutter. He then went over to Broadway and dragged the magnet along for a whole block. After these trials he hung the magnet upon an iron pillar of the railway in the wind, examining it frequently. The young man was Mr. Joseph Metzler, of the *Scientific American* staff. He explained that he was determining the amount of iron dust from the elevated railways. This dust, he said, is the cause of many severe cases of eye troubles. The swift passing trains grind off showers of iron particles, which often fall or are blown into the eyes of pedestrians. The microscope shows that the particles are of innumerable shapes, and they usually have jagged fringes, and many of them have barbs like a fish hook. When lodged in the eye they cannot be attracted therefrom with a magnet, but a gouge-shaped instrument the size of a sewing needle had been devised for the purpose. The operator showed that in six feet of space under the elevated road more iron was attracted than on a whole block of Broadway, thus proving the responsibility of the railway. When the magnet was hung on the pillar it attracted much iron dust, showing that it floated constantly in the air. Along Sixth avenue the awnings are coated with iron dust. Shopkeepers complain that the iron will not wash out, but eats up the awnings.

The editor of an alleged trade paper published in Chicago takes occasion in his last issue to make an assault on the New York Jewelers' Club. Most of his statements are, to put it mildly, grossly erroneous—in fact, it would be a difficult thing to compress more misstatements into a similar space. He complains because the Club has been limited to the East and does not include the Western and Southern States. The New York Club was organized among New York Jewelers for social purposes, with the object of cultivating each others acquaintance more intimately; it was intended as a local affair entirely; as such it exchanged courtesies with a similar club organized for similar purposes in Providence. Both these clubs became popular in the trade, and that of Providence enlarged its field to include the jewelers of New England, changing its name to correspond; the New York Club, at a recent meeting, changed its by-laws so as to admit to membership any person engaged in the jewelry business regardless of locality. If anyone in the Western or Southern states desires to join they will be made welcome, but it is understood by everyone except the obtuse editor referred to that this is a social organization exclusively, and not intended to consider or act upon trade matters. The same individual asserts that the original members of the club have deserted it; six or eight members only have withdrawn, some having died, others removed to other cities and still others having gone out of business, but new members have joined to more than make up the withdrawals. Perhaps if the disgruntled individual referred to were appointed Director-General of the Club he would not make occasions to ventilate his dissatisfaction.

H. A. Brahe, of Augusta, Ga., announces that he has disposed of his stock, fixtures, assets, etc., to B. Von Hopffgarten for \$25,000, payment secured by notes and mortgage on stock and property purchased. Mr. Brahe estimates his liabilities at \$14,000, and proposes to turn over to J. E. Harpe and John Davidson sufficient of the notes of the purchaser thus secured to be held by them for the benefit of his creditors. Mr. Brahe states that the creditors will be more secure than before because of the mortgage on the stock.

July 1st is the date fixed upon for the annual re-union of the New York Jewelers' Club, and, as we are obliged to go to press several days in advance of that time, of course we can give no report of the festivities in this issue of THE CIRCULAR. Suffice it to say that the committee having the matter in charge made every arrangement to insure the complete success of the programme, and to secure the comfort and enjoyment of all in attendance. The programme contemplated the assembling of the New York and New England Clubs at the Astor House on the morning of the 1st of July; a parade down Broadway; embarkation on the Iron Steamboat Company's elegant steamer *Pegasus*, chartered for the occasion; a sail to points of interest about the harbor; and, finally landing the excursionists at Coney Island, where a banquet was provided at the Brighton Hotel. We can readily imagine that this programme was successfully carried out, and that fun and jovial, genial, refreshing relaxation and social enjoyment characterized the proceedings from first to last. There were plenty of witty speakers in the party to reply to any toasts that might accidentally be sprung upon them, and there were storytellers overflowing with anecdotes, original and aboriginal, and there were soloists, duetists and quartetteists prepared to inflict excruciating torture upon all listeners with their vocal gymnastics. We regret to state that no chaplain could be induced to accompany the excursion, but an accommodating caterer was engaged to provide mild spiritual consolation in a liquid form, which, mixed with ice and imbibed through a straw in limited quantities, was intended to carry peace and happiness to the souls of all who partook thereof. As all previous re-unions of the Club have been most enjoyable social events in the lives of the overworked members of the trade, affording them much needed recreation, there is every reason to believe that the festivities of 1884 were or will be equally successful.

The circular issued by the American Watch Company announcing that they would protect the retail trade from the disastrous results that might otherwise come to them in consequence of future cuts that may be made in the price of watch movements, has created a decided sensation in the trade. It guarantees the dealers against loss from any depreciation in the value of any American movements they may have on hand in case it should be found necessary for the Company to reduce its prices to meet competition that may be forced upon them. It is well known that the prices of some movements have already been reduced, and a further cut is imminent. When such reductions have been made heretofore, the manufacturers have protected the jobbers by allowing them a rebate for stock on hand, but retail dealers have been allowed to stand the brunt of the depreciation. The course pursued by the American Watch Company in guaranteeing a similar rebate to the retail dealer, makes a precedent the observance of which will be insisted upon in future. Manufacturers have too often stocked up the trade with their goods, and then, in order to force the sale of more, suddenly reduced the price, thus depreciating the value of those held by the retailers and the jobbers, and the former are entitled to fully as much protection against loss as the latter. When a manufacturer determines to undersell what have heretofore been his standard prices, he should be prepared to assume the cost such reduction will bring to the trade. This the American Watch Company announces it is prepared to do. It has not as yet found it necessary to cut its standard prices, but being apprehensive that the competition which it encounters may force it to do so, it warns the trade in advance that it is prepared to assume all the loss that may attend any reduction it may make. Dealers who have been loaded up with other movements and now find the prices cut under them, will fully appreciate the importance and fairness of the policy announced by the American Company. While we regret to see competition carried to the extent of breaking down established prices for standard goods, when manufacturers reach that point, justice and equity alike demand that they should protect from loss those who have, in good faith, bought their goods at the old prices. When a dealer who is stocked up with movements at old prices, finds that his competitor can go into the market and buy them at the new prices and sell them at retail at a profit for what his actually cost him, he is apt to feel that he has been badly treated. The precedent established in this respect by the American Watch Company will, we doubt not, be insisted upon by retail dealers hereafter.



Obituary.

D. H. HOPKINSON.

IT IS WITH the deepest sorrow that we have to announce to the jewelry trade the death of Mr. D. H. HOPKINSON, for so many years the sole proprietor and directing spirit of THE JEWELERS' CIRCULAR. His death occurred on Friday, July 25th, at his residence, No. 310 Clinton avenue, Brooklyn, in the forty-fourth year of his age. It has been Mr. HOPKINSON'S practice for several years to spend the month of June with three friends fishing in the wildernesses of Canada. This year the party consisted of Mr. HOPKINSON, EZRA C. FITCH, AUGUSTUS K. SLOAN and CHARLES SLOAN. They left this city May 28th, and a week later had disappeared, with their Indian guides, in the Canadian woods, and for the ensuing three weeks were lost to civilization. On their return Mr. HOPKINSON was taken ill at Bangor, and his companions report that he had complained of various ailments while on their excursion. At Bangor it was found necessary to summon a physician to prescribe for Mr. HOPKINSON, and he was joined there by his wife and daughter. The fever with which he was seized did not yield readily to treatment, and he was finally brought home to Brooklyn. While his sickness was pronounced to be a stubborn fever, little apprehension was felt at first by the physicians who attended him, but he gradually grew worse, and a complication of troubles set in, apparently affecting in turn every vital organ. His temperature ran up alarmingly high and then fell to a point which seemed to threaten instant dissolution, and for two weeks or more these violent fluctuations continued from day to day, baffling the skill of the several eminent physicians who were called to attend him. His strength was constantly failing, and finally that point was reached when all hope of his recovery was abandoned. Yet for many days more his strong will and splendid constitution kept up the fight with the dread

destroyer, till finally his strength was exhausted, and he found rest and peace in death.

“—like a clock worn out with eating time,  
The wheels of weary life at last stood still.”

At this moment, when the last form of this issue of THE CIRCULAR—to which Mr. HOPKINSON had devoted the best energies of his life—is waiting for the press, and while poignant grief fills the hearts of all who were associated with him, it is impossible to speak of him as his life, works and memory deserve. The heart overflows, language refuses to come at our bidding, and the ready pen hesitates as we reflect upon all that he was to us and to so many others, and realize that never again shall we hear his cheery voice, or see his loved form. But justice to his memory and to the readers of THE CIRCULAR demands that the record should be made.

D. H. HOPKINSON was born in Sheffield, England, in the year 1840. The family is one of prominence and influence in that section, but as he was a younger son he had his own way to make in the world, as in accordance with English law, the older son becomes the head of the family and succeeds to the estates. His proud spirit would not permit him to be a dependent upon an elder brother, so before reaching his majority he came to this country to seek his fortune. He brought with him intelligence, capacity, energy, and an indomitable determination to succeed, but only a few dollars capital. It was just at the breaking out of the civil war, and, his sympathies being all with the government, he accepted the first opportunity that offered to enter the government service. He had made the acquaintance of Mr. E. K. COOLEY, of Brooklyn, who was appointed an Acting Paymaster in the navy, and Mr. HOPKINSON, in April, 1861, at the first call for men, engaged himself as clerk to Mr. COOLEY. They were at once assigned to the steamer *Albatross*, Commander GEORGE H. PRENTISS, which vessel formed a part of the North Atlantic Squadron, and was engaged during the war in blockading southern ports. While Mr. HOPKINSON'S position did

not necessarily bring him in the line of active duty, he, nevertheless, was always a volunteer when any dangerous work was to be done, and in this way participated in several boat enterprises for "cutting out" blockade runners, resulting in serious engagements. His executive ability soon attracted the attention of the commander and he made him his confidential clerk in addition to his position as paymaster's clerk. While engaged in this work, Mr. HOPKINSON made lasting friends of the officers with whom he was brought in contact, some of whom were the companions of his late life, and were present at his funeral. They speak of him as having been the life of the ship, at all times overflowing with wit and humor, and contributing greatly to relieve the tedium of life at sea.

At the close of the war, Mr. HOPKINSON returned to New York and became identified with the business department of various publications, more notably with that of *The Evening Mail*. In this branch of business he developed great capacity and was highly successful. In 1869 he conceived the idea of establishing a journal in the interests of the watch making and jewelry industries, and THE JEWELERS' CIRCULAR was the result. It was a success from the very first issue, its high commercial tone and general character commending it to those interested in those trades. Subsequently he purchased a struggling little paper called *The Horological Review*, which he merged with THE CIRCULAR, hence the double title of this journal. What THE CIRCULAR has been to the interests it represents is well known to the trade. It was Mr. HOPKINSON's ambition to give it a high tone as a special journal, to make it instructive to those in the trade and to those about to enter it, and also to give such current news as might occur. He sought to inculcate a high sense of commercial honor and integrity in all business transactions, and was vigorous in denouncing shams and fraud. The soul of honor himself, he endeavored by his teachings to instil similar sentiments in the breasts of others. He was a vigorous champion of the right at all times, and no pecuniary temptation could swerve him one iota from this position. But THE CIRCULAR is so well known and was such a clear mirror of the character of its proprietor, that to comment further upon it would be superfluous.

In his private life Mr. HOPKINSON was one of the most genial, pleasant, companionable of men. The wit and humor that so endeared him to his naval companions remained with him through life. He was always cheerful and jovial, full of anecdote, quick at repartee and exceedingly original in his expressions. The humorous side of all things was the first to attract his attention, but while fond of fun and jokes, he never indulged his humor at the risk of wounding the feelings of another. He loved humor for humor's sake and not as a weapon to stab sensitiveness. He was of an exceedingly sympathetic temperament, and no appeal of distress was ever made to him in vain. His hand was always open to the poor, and he had many permanent pensioners upon his bounty. His charity was frequently abused, as he was well aware, but it never served to check

his benevolence. He had a lovely and happy home in Brooklyn; a wife whom he loved devotedly, and a daughter whom he worshipped. Of a rare domestic disposition, he was never happy away from business except in the company of his wife and daughter. To secure their comfort and happiness was his absorbing thought. The desolation caused in that once happy home by his death is too sacred to be further alluded to.

Although a young man, Mr. HOPKINSON always exercised an elevating and salutary influence upon his associates. High minded, noble, honorable, the soul of integrity himself, "with charity for all, with malice towards none," his personal characteristics made him cherished as a friend and admired as an acquaintance. Once to know him was to desire further intimacy, for his was a nature to command friendship, love and respect. With him a friend was a friend for life. Keen to detect the weaknesses and failings of his associates, he might chide or advise, but never ridicule or satirize them. To those who have been associated with him for many years in the editorial and business departments of THE CIRCULAR, he was more than an employer—he was a friend and a companion. By numerous and unexpected kindnesses he showed his constant thoughtfulness for those with whom he held intimate daily business relations, and bound them to him by personal regard and affection rather than by motives of interest. Did affliction or trouble come upon them he was first to offer sympathy and assistance. Did fortune favor them, none rejoiced more fully than he. In all business relations, no one could be more considerate. Full of resources himself, he was quick to act upon suggestions and to award the full meed of praise to him who made them. He was an indefatigable worker, at his desk early and late, and to this is probably to be attributed the disease which ended his life. Lack of out door exercise and confinement at his desk, undoubtedly planted the seeds of that malaria which assumed so malignant a form. Although of English birth and parentage, Mr. HOPKINSON was intensely American, of which his service in the navy was but a single illustration. After the war he obtained his naturalization papers and became a citizen of the country he loved so well, with all the rights and privileges of citizenship. His sentiments were those of pronounced loyalty to the country of his choice and he was as patriotic in every thought as though born to the soil.

Our chief is gone! and when this brief record of his earthly career shall reach the eye of the reader, the green sward of Greenwood will have closed over all that was earthly of him. But the spirit he possessed and the sentiments he inculcated will still live in the breasts of those who enjoyed his love and his friendship, and his memory will long be cherished by all who knew him.

"His life was gentle; and the elements  
So mixed in him that Nature might stand up  
And say to all the world, 'This was a man.'"



VOLUME XV.

NEW YORK, AUGUST, 1884.

No. 7.

## THE JEWELERS' CIRCULAR AND HOROLOGICAL REVIEW

*The recognized organ of the Trade, and the official representative of the  
Jewelers' League.*

A Monthly Journal devoted to the interests of Watchmakers, Jewelers, Silver-  
smiths, Electro-plate Manufacturers, and those engaged in the  
kindred branches of art industry.

### SUBSCRIPTION:

To All Parts of the United States and Canada,  
**\$2.00 Per Annum; Postage paid.**

To Great Britain, France, Switzerland, Germany, the West Indies, Mexico, the  
Republics of South America, and Australia, \$3.00 per annum. Postage paid.

*All communications should be addressed to D. H. HOPKINSON, 42 Nassau  
Street, New York. Advertising rates made known on application.*

### Commercial Honor.

THE BUSINESS experiences of the past few months serve to illustrate to what a low ebb commercial honor has fallen in this country. Had the high standard that formerly existed been steadfastly maintained, such wild, visionary and discreditable transactions as characterized the failure of Grant & Ward, and some other firms of speculators, could never have occurred. The public has been prompt enough to censure these men—some of whom are now in prison—but the public should beat its own breast and cry “my fault! my fault!” The fact that the public has so long tolerated speculative gambling, and worshipped as heroes the men who have made fortunes by transactions that should have consigned them to states prison, has made it possible for adventurers and swindlers to carry on their fraudulent operations. When we see men and women paying homage to wealth acquired by trickery that is no better than absolute robbery, it is not to be wondered at that the youth of the country becomes greedy for riches, and are ready to resort to any means to acquire them. When millionaires owe their fortunes to “watered stock,” and publicly boast of the railroads they have stolen from their honest stockholders; when fortunes have been made, and are flaunted defiantly in the face of the public, by adventurers who locate, buy and sell bogus mines; when men in business make their profit by adulterating their goods; and when the public sets up men like these as gods to be worshipped it is not surprising that robbery, embezzlement and all the crimes in the calendar are matters of daily occurrence, and that men occupying positions of trust are among the guilty ones. The motto which governs the actions of a large portion of the community embodies the advice given by the old lady to her son: “Get money; get it honestly if you can, but—get money.” The almighty dollar is the only thing they reverence, and by the accumulation of wealth, however the means employed, they expect to command the homage of their fellow-men and the blessings of their Creator.

There was a time when business men would sacrifice everything, even life itself, to maintain their commercial honor; when a merchant's word was as good as his bond, and when every representation he made had truth for its foundation. But those days have passed, and commercial honor, truth and integrity are now counted as relics of old fogyism. In their places we have “sharpness,” “cuteness” and “trickery.” The man who can make money is the one who commands the admiration, if not the respect, of the world. The jewelry trade is neither better nor worse in these respects than other business enterprises. It still numbers in its ranks some “old fogies” who still believe in commercial honor, but there are altogether too many of the other class, who act upon the idea that anything is permissible that puts money in their purses. The standard of quality has deteriorated with the standard of morality, and the country is flooded with every variety of goods for the integrity of which no honest man dare vouch. Debased gold masquerades as the genuine article, and ten karat goods are stamped and sold as fourteen or eighteen karats fine; cut glass and paste are sold for genuine diamonds, and “pinchbeck” has usurped the place of “sterling.” When our legislators have found it necessary to pass laws to prohibit the adulteration of necessary articles of food, which existing practices have rendered so common, it is not surprising that those articles of luxury that come under the head of jewelry should also be degraded in quality. All this is the result of the gradual corruption of the sense of commercial honor that should exist among the people. As citizens we do not condemn and abhor the men who are guilty of dishonorable practices, nor do we attempt to hold them to a strict accountability for the results of their crimes. Courts and juries have developed a wonderful degree of sympathy with criminals, and to such an extent has this been carried that it is found almost impossible to adequately punish even a murderer, while lesser criminals are apt to escape entirely. When a bank officer absconds with the money belonging to hundreds of depositors, the public does not experience a shock or unite in demanding that the guilty man shall be pursued and punished; on the contrary, the general verdict is: “Well, he was smart to get away.” The greatest decadence in commercial honor occurred during the war, which had a tendency to bring the rougher and more reckless element of our population conspicuously to the front, and to give places of trust and responsibility to adventurers. The government was a large purchaser of nearly everything our people had to sell, and the army contractor became an important personage. To swindle the government was regarded as a “smart” thing to do, and the men who made fortunes by sending “shoddy” clothing to the soldiers in the field received more honor than those who won the battles. After the war this rough and reckless element was again absorbed in civil life, and the moral tone of the community suffered in consequence.

Commercial honor is by no means dead—it exists in the breasts of the public to as great an extent, possibly, as ever before—but it lacks manifestation. Bold adventurers prey upon the community with the utmost audacity, and are permitted to go unpunished and unrebuked.

The moral sense, that should revolt at their deeds, has been blunted, and crime flourishes in consequence. Men tolerate in others what they would not be guilty of themselves, shutting their eyes to offences in the way of trade that would, but for their long familiarity with them, provoke their righteous indignation. It is not necessary to specify how this is illustrated in the jewelry trade, for examples will occur to every one who deals in jewelry. It would be a good thing if the old methods and habits could be restored, at least such parts of them as combined absolute honesty and integrity. Perhaps the day will come when commercial honor will come back with all its pristine simplicity and vigor, but it will take years of education to bring it about. Meantime every individual should do all in his power to inculcate better ideas of commercial integrity and common honesty to the rising generation than are at present popular.

---

### Business Failures.

IT WAS, of course, expected that the report of failures in the United States and Canada for the quarter ending with the 30th of June would show a very decided increase in the amount of liabilities, resulting from the disturbances in Wall street in the early part of May. We pointed out immediately after these occurrences that the trouble appeared, in the language of the medical reports concerning diseases, to have been to a considerable extent "localized," and that there was very little evidence of unsoundness throughout the country. This opinion is fully confirmed by the report of Messrs. R. G. Dun & Co.'s Mercantile Agency, covering the first six months of 1884.

According to this report, there was in that period an increase of 873 failures as compared with the first six months of 1883, or about 18 per cent. The total number was 5,510. The increase in the amount of liabilities was from \$66,000,000 to \$124,000,000, or 88 per cent. Of this increase of liabilities, however, \$48,000,000, or 83 per cent., are chargeable to the city of New York, and only \$18,000,000 to the remainder of the country. In other words, the increase of liabilities in the first half of 1884 over the first half of 1883, outside the city of New York, has been from \$55,000,000 to \$67,000,000, or only about 22 per cent., instead of the 88 per cent. which is shown with New York included. It must be remembered, also, that this is but a rough comparison. Only the amount of liabilities is given, or can be given. The result might be quite different could we know the net assets of the insolvents or the terms on which liquidation has been or is to be effected. There is little reason to doubt that with this more complete comparison, the extent to which this very great increase of liabilities shown in the reports has been caused by the recent troubles in Wall street would appear more marked than it now does. This conclusion is strengthened by the fact that in this city, where the difficulty has been most intense, the mercantile community, though it has unquestionably suffered, has added very little to the list of insolvents.

We have to repeat, therefore, what we have said heretofore, that the country is, on the whole, in a condition by no means discouraging. There is not much incentive to speculation; there is great reason to be confident of a fairly profitable general business. There is little inducement to put surplus profits in so-called securities. There is a fair inducement to put them into regular business channels with the expectation that they will yield reasonable returns. And it is worth while again to suggest that the "losses" involved in the decline of speculative securities on the Stock Exchange appear far greater than they really are, because, to a considerable extent, the wealth that has shrunk did not in fact exist. Men who thought that they were "worth" a great deal of money find that they are not; but it is not as if property had been burnt up or goods manufactured at a high cost had become unsalable except at very low prices. It is the tumbling of castles in the air, which

were never fit for habitation, and whose destruction leaves their fond owners as capable as ever of earning an honest living in legitimate ways. While it is true that there has been, as a result of the crash in Wall street, what is termed "a shrinkage of values" aggregating many millions of dollars, it should be remembered that these values were largely speculative, and were the creation of the gamblers who make a business of manipulating the stock market. The property on which these stocks were issued has suffered no depreciation in value, however the stocks themselves may have fluctuated. The man who bought railroad shares as a legitimate investment lost nothing, for the property still exists, and he has but to hold his stocks till the market improves to obtain all they are worth. If those gamblers, who buy and sell on speculation what they do not own, have got burned in these transactions, honest men will not regret it. Speculators who operate on "margins" do so without regard to the actual value of the property represented in the transaction, but depend for their profits upon the manipulations of the market by those interested. If every man who gambles in this manner should lose his "stake" every time it would be far better for legitimate business and for the country. It is a good sign that many men who lost in the recent crash have abandoned speculation for the future, and are putting the capital they have left into legitimate business enterprises. We hope to see before long some legislation that will tend to break up this speculation in fictitious values. Meantime business men should seek to discountenance it, and to imbue the rising generation with a better estimate of what constitutes mercantile honor.

---

### Pirates of Patents.

THERE HAS been a great amount of complaint of late regarding the pirating of patents by one manufacturer from another. Scarcely an issue of THE CIRCULAR appears that does not contain a warning from some manufacturer to the effect that certain goods that he has devised and obtained patents for are being made by others in utter disregard of his rights. The practice has become so common that the trade regards it as a matter of little importance, and manifests a readiness to buy of the pirate quite as freely as of the one who spent his time and money in developing the novelty. There must be a very small sense of honor or self-respect remaining in the man who will deliberately set to work to rob another of the fruits of his labor, and to profit by his skill and industry. Manufacturers spend large sums of money to keep the trade supplied with new and attractive designs in jewelry. Some of them keep artists and designers employed constantly in getting up novelties. When they succeed, patents are applied for, and the new design becomes as much the property of the patentee as does his house, his watch, or anything else for which he has paid. It is quite as much a robbery to appropriate the rights conveyed to him by his patent as it would be to steal his watch, or to sell his house and give a bogus title to it. Probably not one in a hundred of the patented designs in jewelry are successful; they do not hit the fancy of the trade, and fall dead, leaving the patentee out of pocket for the money paid for his patent and whatever goods he has made up, to say nothing of his time and trouble. Even the successful goods have but a limited run, for fashions change, and new things are constantly coming up. But it is only the successful designs that the patent pirates feel inclined to steal. A manufacturer may patent a dozen designs and only one prove successful; when a demand for this one has been created, he immediately finds that some of his unscrupulous competitors have filled the market with the same goods without saying so much as "by your leave." Sometimes the outraged patentee begins suit against the infringer, but the interminable delays of the law are such that his anger cools down before a trial is reached, the style of goods goes out of date, and he abandons the prosecution or compromises.



Instead of having reaped a fair remuneration for his invention, the chances are that he will find himself out of pocket.

It has become a common thing to scout at a patent, and to ridicule the idea that it covers a right to property, or gives the patentee any rights whatever that anyone else is bound to respect. This is an erroneous idea entirely, for a patent is property quite as fully as coats or boots, houses and lands. A man who would think it a great sin to steal your coat, will not hesitate, however, to rob you of your patent rights. The government of most countries has deemed it wise and prudent to encourage inventors by issuing to them patents for novel and useful ideas, which give them the exclusive privilege, for a certain term of years, of manufacturing and selling the article specified in the patent. Our government has followed the example of older nations in this respect, and it is because of the rights conferred by government patents that the United States has become famous throughout the world for the number of its inventors and the genius and skill they have exhibited. Their ingenuity has made life easier to every member of the community; no great enterprise exists in the country that does not bear evidence of the inventive genius of our people. It is eminently just that they should be protected in their labors, and, to their credit be it said, the courts almost invariably take this view of the case, sustaining the rights of the patentee against those who would rob him of the fruits of his labor. It is to the direct and personal interest of every individual that the rights conveyed by a patent should not be violated, for there is not one of us but enjoys, in some form, benefits for which we are indebted to inventors. Manufacturers especially should hold a patent as something almost sacred, for there are few, if any, that have not had their work made easier by machinery or devices which some inventor has patented. They should respect in others that which they may sometime possess themselves and be extremely jealous of. The jewelry trade is largely indebted to inventors, designers and artists for the excellence that has been attained in the manufacture of their goods. It ought to jealously guard the interests of inventors and accord the highest respect to a patent. To attempt to evade it, either by directly appropriating all that it specifies, or, by some quibble, to adapt what it covers to something slightly different, is no better than robbery, for by so doing the inventor is deprived of that which is absolutely his—the work of his brain. It is difficult to see how men who would scorn a thief or a robber, can reconcile it to their consciences to deliberately steal a patent—to make goods after a design that is the property of another, thereby depriving him of that which by right belong to him, the profits on the sales of the article patented. Such men certainly cannot expect to have the confidence or respect of their fellow-men.

OUR readers will remember the case of S. Rothschild, of Memphis, who failed some time since in a most disgraceful manner, and who was convicted of various offences in connection therewith, and sentenced to three years' imprisonment. He succeeded in carrying the case to a higher court and there the sentence was confirmed. A petition for his pardon was then presented to the Governor of the state, on the plea that his health was such that his life would be endangered by imprisonment. This petition was, we understand, urged upon the Governor by influential politicians, and a pardon was granted to Mr. Rothschild. As soon as the creditors who had been defrauded learned that the petition for pardon was being circulated, a remonstrance was signed by a majority in numbers and amount of the creditors and sent to the Governor. This arrived too late, however, for in his haste to oblige his political friends, the Governor had already signed the pardon. Suits are still pending against some of the persons to whom Rothschild is believed to have transferred some of his stock on the eve of his failure. It seems like a travesty of justice when the Governor of a State has the power to set

aside so righteous a sentence as this was, especially after it had been confirmed by an appellate court. It is in substance offering a premium for the repetition of such offences as Rothschild was convicted of committing. Common courtesy would have dictated that his victims be accorded a hearing before he was turned loose again upon the community.

THE APPEARANCE of cholera in various cities of France, where it has been attended with exceedingly fatal results, has naturally excited considerable apprehension. In these days of rapid international transportation it would require but a brief space of time to disseminate the disease throughout the civilized world. The fact that it follows the regular lines of travel and commerce, being conveyed in clothing, goods, etc., and that it is raging in the most populous cities of France, renders it almost certain that it will appear in other countries. The authorities of England have already adopted precautionary measures, and our own health officers are also on the alert. On another page we present some suggestions made by the State Board of Health as to the means to be adopted to prevent the disease gaining a foothold this side the ocean. Cleanliness, moderation in eating and drinking, and the best sanitary precautions are essential to the preservation of health when cholera rages. It behooves every individual to take proper care of himself and to keep his system in such condition that it will be able to resist disease of whatever nature. Cholera is better understood now than it was when it visited us before, and medical men feel greater confidence in their ability to cope with it, but "an ounce of prevention is worth a pound of cure," and it is better to take care of ones self than to trust to the doctors. The epidemic will, no doubt, interfere with the plans of some members of the trade who are now abroad on business and pleasure trips, but if they return in health and safety they can afford to forego some of the pleasures to be found in the French capital.

SUBSCRIBERS to THE CIRCULAR who desire to have the address of their paper changed, will oblige us if they will, when ordering the change, name the place to which it is now sent as well as the place where they desire it to be sent in future. To show the confusion the neglect to do this makes, let us illustrate: John Smith writes, "please send my paper to Peoria in future." There are twenty-seven John Smiths on our subscription books, and the question arises, which one is going to honor Peoria with his presence in future, and which John Smith's paper shall we send there? Please be explicit in all orders.

#### The Improving Business Aspect.

THE IMPROVED feeling in financial circles here can scarcely fail to have an early response from other commercial and business centers; for whatever may be said of Wall street in other respects, there is no question that the prevailing feeling there, whatever it may be, is a tolerably accurate gauge of the business pulse throughout the country. In this instance, however, it is not certain that the common experience is reversed, and that Wall street now is but responding to the improved conditions with which the country itself may be felicitated. Abundant harvests can be safely expected, which implies a continuance of cheap food at home with a large surplus for export, which means in turn increased traffic for the railroads, and a new lease of prosperity for the various important interests with which they are associated. The farmers, consequently, are in good position to enlarge their purchases for the fall and winter, and as stocks of goods at the leading distributing points are far from excessive, it will not

be long before the markets at the sources of supply will experience healthful activity. This, in turn, will help the manufacturers, many of whom are still in the slough of despond. The iron trade, and its wide circle of dependent and interdependent industries, if without special activity, is in good shape for returning improvement, and the fact that the anthracite coal combination, after a season of prolonged restriction, have put up their prices this month, is an indication that they at least are confidently looking forward to a strong market; for that matter, an increased demand is already reported. In some portions of the country we have still a faint echo of workingmen's strikes, but this amounts to little, in presence of the fact which cannot be gainsaid that the laboring classes to-day almost everywhere are fairly employed, and if wages have been reduced there has been an offsetting advantage in lower prices for the necessaries of life. Nor has the commercial position many weak spots. Merchants continue to sail close to the wind, but their exemption from disaster during the recent financial storm in the street is proof positive that they have a firm anchorage, and are in good shape to avail themselves of the favoring breezes which must come with the turn of the tide. The excitement incident to a Presidential election is always more or less a disturbing influence; but, as this campaign promises to be singularly free from irritating issues, we are disposed to think it concerns the politicians more directly than the people. Trade will not be materially affected by it, and, no matter which party wins, we may solace ourselves with the traditional reflection that the "country is safe."

Our exchanges from different sections of the country confirm this hopeful view of the trade prospects. "For the next few days," says the *Chicago Times*, "a dull time may be expected in dry goods, clothing, hardware, groceries, drugs, etc., but if the southwestern crops turn out as abundant as they promise a revival of trade with that section will set in during the latter part of July that will improve the business situation wonderfully. Northwestern trade always begins much later, owing to the fact that the harvests are later than in southern latitudes, and it is too early to speak with confidence of the fall trade with that portion of the country. At present, however, the outlook is exceedingly good."

The *St. Paul Press-Pioneer* says: "Money matters are in a very satisfactory condition in the Northwest, and the banks of St. Paul and Minneapolis are exceptionally strong. Wholesale trade is rather quiet, but not duller than usual at this season. Dry goods are in fair request, and there has been considerable personal buying during the past week. Other lines report a steady business. Collections are good in most lines, and in some cases much better than usual."

*St. Louis Globe-Democrat*: "In most lines of trade there is the dullness incident to midsummer, to harvest time and the half-yearly settlements. The gathering and attending of crops always induces quietude in trade centers. An exception is found in the case of groceries, as in this line country dealers are taking supplies to feed the harvesters."

*Charleston (S. C.) News*: "A substantial improvement in the general condition of the State is exhibited by the small number of failures and the trifling embarrassments which have followed the short crops of last year. In spite of the stringency of the money market, caused by the failures in New York and elsewhere, South Carolina has kept the even tenor of her way, and is in position to enjoy to the utmost the blessings of favorable seasons."

The *New Orleans Price-Current*, after saying a reaction from the recent depression is at length discernible, adds: "Money circles show signs of improvement, and though loans are not plentiful and rates are still high, small demands are being more readily accommodated. The improvement is necessarily slow, as is to be expected, for, however sudden and erratic disaster may be, recuperation is uniformly slow and monotonous."

*Baltimore American*: "Aside from the development of a more hopeful feeling, the general trade movement is one of quietude. The entire country would appear to be waiting for the subsidence of what

has been aptly termed the rich men's panic in Wall street, and until this has been accomplished the present quiet condition of business affairs is likely to continue. To sum the matter, the country was never before so rich and so full of material wealth; the essential elements for renewed commercial activity are at hand, and there is only lacking the vitalizing force of perfect confidence in the integrity each of the other."

The Canadians also are beginning to turn the corner of the "hard times," crediting the following optimistic view of the situation from the *Montreal Herald*:

"Harvesting operations have already begun in some localities, so that before many weeks have elapsed all will be housed. The prospect is bright. Buying has been on a small scale for some time. 'Cut your coat according to your cloth' has been the axiom of the day, and while traders have been extremely cautious in the selection of their customers, the customers have been equally cautious not to purchase more than was actually needed to carry them along. In this way stocks have been kept low and debts have been avoided, so that whenever circumstances will enable buyers to come freely into the market, they will not be kept back from purchasing by any consideration such as even a partial stock on hand."

[Copyright Secured.]

### The Cup—Its Art and Customs.

[BY JOHN W. MILES.]

*Continued from page 182.*

AMONG THE curious shapes were standing cups in the form of a gourd, which were quite popular before the close of Elizabeth's reign. One of silver parcel gilt, at Broderers' Hall, London, figure 55, rests upon a stem in imitation of the trunk of a tree with lopped branches. The cup is ornamented with fruits, flowers and winged figures in *repoussé*, and the finial of the cover is a bunch of enameled flowers. Sometimes the stems represented the stalks of



*Gourd Cup, A. D. 1611, Figure 55.*

the gourd or melon, and the German work of this style had also the figure of a man chopping at them with an axe. Quaint cups were also produced in the shape of birds or animals, the heads serving for the cover, which, when removed, revealed a drinking vessel. Of these cups the Pea-hen cup gives a good idea, figure 56. It was

presented to the Skinners Company of London by the widow of a Mr. Peacock. The "Cockayne" cups were of this style.



*Pea-hen Cup, Figure 56.*

A favorite cup in France, Germany and England was the "wager cup" one being illustrated in figure 57. It was a double cup, the lower part serving in that capacity by reversing the piece. Sometimes the pail carried on the head of the woman was so fixed on a swivel that the uninitiated, when attempting to drink, invariably received its contents on their neck or chest. It reminds one of the porcelain Chinese "Cup of Tantalus," which is so arranged with a concealed syphon that the expectant drinker is deluged before the cup reaches his lips. Another fashion of cups in the shape of wind mills were in use by both the Germans and French, and sometimes assumed the character of "wager" cups. The one illustrated in figure 58 is French. It is of silver and belongs to the 16th century. By blowing into the little tube at the right the wings of the mill revolved and the number of revolutions was indicated upon the dial. The person who could cause, in this manner, the greatest number of revolutions was entitled to the wine, which was served in the lower part by reversing the cup.

We have traced the cup through many centuries of time and through a great variety of styles, and the writer desires to express here his obligations to Messrs. W. J. Cripps, John H. Pollen, Henry B. Wheatley, Philip H. Delamotte and many others for much valuable information, and to their several publishers for electrotypes of many of the illustrations, without which the different styles would have been very difficult to explain.

Art is a story that may be told imperfectly or perfectly; in serious or grotesque humor; in plain prose or majestic poem; and the excellence and mode of its expression determines its rank. In this sense it applies to everything made by the hand of man. But there is yet another law that determines the material by which thought shall be expressed and what may or may not be used, and this law requires that articles of gold or silver should be in beautiful forms. Not that other materials should not also exhibit beauty, but that the noble metals particularly should be so wrought. There is a beauty in the metals themselves, whether with a burnished or dead surface,



*Wager Cup, Figure 57.*

that is possessed by no other material, and their cleanliness and adaptability for various purposes of use or ornament especially designates them as mediums of sentiment. When, therefore, design carries no nobler and purer thought than vulgar display, or is made up of parts thrown together in an incongruous medley, it is debased and the metal is debased with it; but when it answers its full purpose and becomes a living page of expressive feeling nothing is more richly beautiful and true. The cups selected to illustrate the art of the various nations are all of the best that have been preserved, and hence may be accepted as the highest stage of the art of their period. From them one can understand a great part of the life of those who produced them. They tell their own story, and if many, or all, of the forms are familiar to us we must not forget that to the artist who first produced them they were original. Upon them the artist of to-day depends for inspiration, and the combinations which he may be able to weave out of the various styles are artistic or not as they may be harmonious or inharmonious. Under present conditions it is vain to hope for any thorough and positive originality in design. There may be innumerable combinations, good, bad and indifferent, but there can be no pure invention until universal culture creates a

demand sufficiently strong to not only stimulate genius but also amply reward it. There are signs that such a day is approaching,

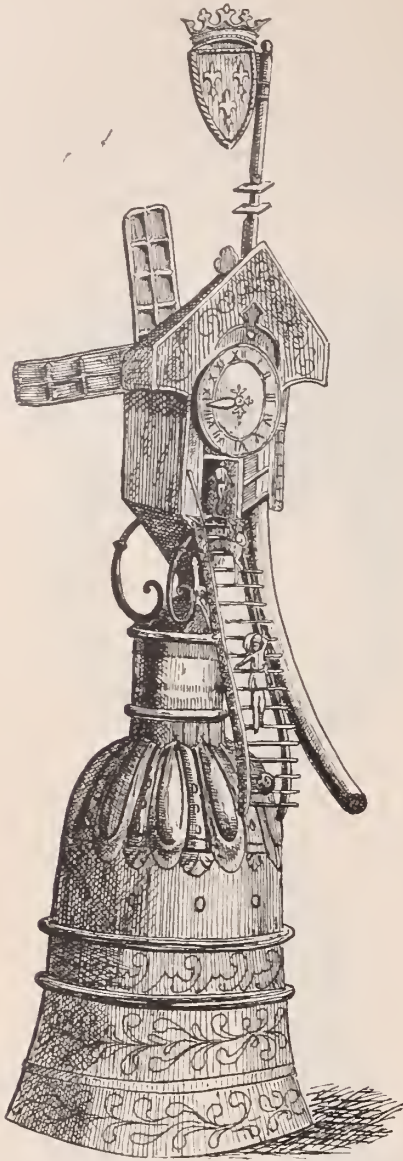

Wind Mill Cup, Figure 58.

and that among the numerous things of value America has given to the world shall be included a beautiful American Art.

[THE END.]

### The Tourbillon Escapement.

**S**PEAKING OF the tourbillon, M. Grossmann says that it is not by any means a distinct escapement, but only the peculiar arrangement of one; in consequence of this disposition the latter revolves with all its parts as a whole around the stationary fourth wheel, and the axis of the fourth pinion is also that of the balance.

The tourbillon is one of the felicitous conceptions of the illustrious Abraham Bréguet, who by this arrangement sought to render the rate of the watch independent from the disturbing influence exerted upon it by a non-equipoised balance. This arrangement can consequently be employed only for watches, as other kinds of escapements do not require it by reason of their fixed position. The introduction of the tourbillon in watches, however, is extremely difficult and tedious, and escapements arranged in this manner are very dear and rare.

The ordinary running work cannot be used for the purpose without making several small changes. The second wheel and pinion are to be taken out; the latter one is replaced by another one of the same size, but with longer staff, and it must in the dephing tool be

placed as near as possible to the center of the plate, without exposing it to immediate contact with the barrel tothing.

This pinion is with its lower pivot placed in the plate, while a collet is fastened upon the upper end of the arbor, which receives no pivot. This collet, which carries the entire escapement frame, must have a surface about 5 or 6 millimeters above the upper plate, upon which the frame is fitted.

We next come to this frame. I have always made it of German silver, partly for the sake of good appearance, partly, however, on account of the hardness and elasticity of this metal. Without desiring to establish standard proportions, I annex those generally used by me.

|   |              |      |
|---|--------------|------|
| Diameter of plates.....                 | millimeters, | 68.0 |
| Thickness ".....                        | "            | 1.1  |
| Height of pillars.....                  | "            | 9.5  |
| Diameter of balance.....                | "            | 49.0 |
| Thickness ".....                        | "            | 2.6  |
| Breadth of rim of balance.....          | "            | 4.2  |
| Diameter of scape wheel (15 teeth)..... | "            | 24.9 |
| " roller.....                           | "            | 11.3 |
| Distance of wheel from balance.....     | "            | 17.5 |
| Height of scape wheel bridge.....       | "            | 5.0  |

Although I said above that any optional escapement may be arranged as tourbillon, still, in the majority of cases the chronometer escapement is used most for the purpose, as the entire arrangement does not admit of a mediocre or an inferior workmanship. I have found that the German chronometer escapement is best adapted, as only a small length is necessary for the detent piece, while the detent spring must always be of a certain appropriate length.

The frame plates must be exactly true, and the lower plate is with its center hole fitted upon a strong pivot, which is turned on to the pinion, so that it projects above the collet face. After the plate has been truly fastened in this manner, it is fastened to the collet by means of two good foot pins and three screws. The aforesaid pivot is then turned away, so that nothing of the pinion arbor projects beyond the collet face.

Next center and fasten in the same manner a short arbor with collet to the outer side of the upper plate, and also turn the pivot away, which has served for centering. We now have a frame, for which the second pinion of the running work serves as axis, and which revolves upon this. The axis must be disconnected within the frame, because the balance staff is to be mounted exactly in the direction of this axis. The jewel holes and cap jewels of the balance are set in the holes of the two plates which previously served for their being centered, so that the cap jewels do not protrude to the outside. This done, the scape wheel and other parts of the escapement are mounted in the usual manner, and their arbors are turned in. The scape pinion must project to the lower side of the frame, and a bridge, 4 mm. high, must therefore be located for it.

It is necessary next to truly center and screw on a collet 3 mm. thick upon the upper plate of the running work frame, which carries the wheel, which is also to be centered to the exactest in the axis of the scape frame.

I have used a 10-leaf pinion as scape pinion, and given 75 teeth to the wheel for this pinion. But the sizes of wheel and pinion must be arranged thus that the dephing distance coincides very exactly with the distance from the scape wheel to the balance. This has been given above at 17.5 mm. According to this, the sizes for wheel and pinion can easily be found.

The collet which carries the fixed wheel, is made of such a size that only a little of the tooth circumference of the wheel reaches beyond it.

After all this has been done, efforts must be directed toward making the frame for the escapement as light as possible, to be done by cutting away all the superfluity of metal from the plates, wherever it is not actually necessary. For this purpose both plates are cut out

very delicately, and beside the rim and shanks, only enough of metal necessary for the fastening of the bridges, etc., is left standing.

It is moreover necessary to establish an exact equipoise of the frame, including all parts pertaining into it—as carefully as is done with a balance.

A pivot is turned to the upper short arbor, and the pinion with escapement frame, the lower pivot of which runs in the lower plate of the large frame, is also located above in a bridge of suitable height and size, and provided with caps to lessen friction.

From this arrangement results the following operation: The power of the mainspring, transmitted to the second pinion, propels this, and with it the escapement frame fastened upon it, around its axis. The axis of the escapement frame hereby describes a circle, the radius of which is 17.5 mm. But as the stationary wheel has been screwed upon the plate of the large frame concentric with this circle, and as the upper motion radius is equal to the depth distance for this wheel and the scape pinion, the motion of the scape pinion around the stationary wheel produces exactly the same revolution of the scape pinion and wheel as when the depth occurs under ordinary conditions. The performance of the escapement, however, within its frame, in all respects takes place in the known manner.

Different views may be entertained on the practicability of an escapement arranged in this manner for the purposes of an exact measurement of time, in accordance with whether the subject is reviewed from a theoretical or practical standpoint.

Let us at first state that in a watch with tourbillon a noticeable overpoise of the balance even is without essential influence on the rate of the watch, when in a vertical position, because the position of the heavy point of the balance changes constantly. On the other hand, however, the entire frame, together with its contents, will have to be carefully brought into equipoise. Beside this, it is also doubtful whether anyone would execute a work demanding such an extraordinary degree of exactness as the tourbillon, and would then neglect to equipoise the balance—a labor performed even in the most inferior grades of watches.

Again, it lies in the nature of things that a watch with tourbillon must be large and thick, and that, in spite of this, it offers as little space as a medium-sized ladies' watch for the location of the operating parts of the escapement.

It is unnecessary to state the advantages and disadvantages of the tourbillon escapement. To sum up, they are constructed only in Switzerland, by the most skillful watchmakers; they are extremely delicate, costly, and easily damaged, while repairs on them are very costly.

In 1879, of 128 watches of precision submitted to the astronomical bureau in Neuchatel for observation, there were four with tourbillon, equalling in exactness those with spring escapement, and excelling those with detent.

The cause of their exact rate may chiefly be sought in the preciseness of their execution, but since they require so great a precision of construction, they will never seriously enter into everyday use.

### Computation of Time and Changes of Style in the Calendar.

Addressed to Students of History and Genealogy.

[BY SPENCER BONSALL.]

Continued from page 183.

#### CALENDAR OF THE "SOCIETY OF FRIENDS."

THE numerical designation of the months used by the Society of Friends did not originate with them. In the calendar of Julius Cæsar the months were not only named, but were also numbered, thus:—

- |           |            |               |               |
|-----------|------------|---------------|---------------|
| 1. March. | 4. June.   | 7. September. | 10. December. |
| 2. April. | 5. July.   | 8. October.   | 11. January.  |
| 3. May.   | 6. August. | 9. November.  | 12. February. |

We find in early records, long before the advent of the Society of Friends, that dates were frequently given, in which the numbers of the month only was used, in accordance with the above arrangement.\*

Soon after the arrival of William Penn in this country, numerous laws were enacted for the government of the Province. Among them was one relating to the days of the week and the months of the year, which is here given *verbatim* from the original MS. document, in possession of "The Historical Society of Pennsylvania," and which is entitled:—

"The great Law or the Body of Lawes of the Province of Pennsylvania and Territories thereunto belonging Past at an Assembly held at Chester (alias upland) the 7th day of y<sup>e</sup> 10th month, called December 1682."

The 35th section is as follows:—

"35. And Be it further enacted by the authority aforesaid that the dayes of the Week and y<sup>e</sup> months of the year shall be called as in Scripture, & not by Heathen names (as are vulgarly used) as the first Second and third days of y<sup>e</sup> Week and first second and third months of y<sup>e</sup> year and beginning with y<sup>e</sup> Day called Sunday and the month called March." †

At the time the English Government passed the act requiring a change from *old style* to new, it became necessary for the Society of Friends to take action on the subject, which they did in this manner:—

"Extracts from the Minutes of the Yearly Meeting held at Philadelphia for Pennsylvania & New Jersey from the 14th to the 18th day of the Seventh Month (inclusive), 1751.

"Began Business on the 17th, being the third day of the Week.

"Israel Pemberton, Caleb Cowpland, Ennion Williams, Daniel Smith, Ebenezer Hopkins, & Joseph Parker are appointed to adjust the Accounts, and report the state thereof to-morrow.

"On the 18th . . . . .

"The Clerk is directed with the Extracts of the Minutes of this Meeting to send copies of the written Epistle from the Yearly Meeting of London, this year, directed to the Quarterly & Monthly Meetings of Friends in general.

"Agreed, that Friends within the Compass of this Yearly Meeting should concur with the Minute of the Yearly Meeting in London concerning the Method of computing time as prescribed by a late Act of Parliament, which Minute is as follows, Viz:—

"Agreed, that, as by the late Act of Parliament for regulating the Commencement of the Year, it is ordered, that the first day of the Eleventh Month next, shall be deemed the first day of the Year 1752, and that the month called January shall be successively accounted the first month of the Year, and not the Month called March, as heretofore hath been our Method of Computing.

"That from and after the time above mentioned, the Eleventh

\* In the distribution of the days through the several months, Julius Cæsar adopted a simpler and more convenient arrangement than that which has since prevailed. He had ordered that the first, third, fifth, seventh, ninth and eleventh months, that is March, May, July, September, November and January should each have 31 days, and the other months 30, excepting the twelfth month, February, which in common years should have only 29, but every fourth year 30 days. This order was broken to gratify the vanity of Augustus, by giving the sixth month, bearing his name, as many days as July, which was named after the first Cæsar. A day was accordingly taken from February and given to August; and in order that three months of 31 days each might not come together, September and November were reduced to 30 days and 31 given to October and December.

† It would appear from this, as though the year was to have commenced on the 1st day of March, and it is so stated by Hazard, in a foot-note on page 57, vol. 1. of the "Minutes of the Provincial Council of Penna." That this was not the case, may be seen by reference to "Votes of the Assembly of Penna.," to the Journal of George Fox, founder of the Society of Friends, and to the writings of William Penn, where double dating is always used until the 25th of March, the commencement of another year.

month called January, shall thenceforward be deemed & reckoned the First month of every year, & to be so styled in all the Records & Writings of Friends, instead of computing from the month called March, according to our present Practice: And Friends are recommended to go on with the Names of the following months numerically according to our Practice from the beginning, so that the Months may be called & written as follows, That named January to be called and written the first month, and February to be called and written the Second Month, & so on. All other Methods of computing or calling the months unavoidably leading into Contradiction.

"And Whereas for the more regular computation of Time the same Act directs, that in the Month now called September, which will be in the year 1752 after the second day of the said month, Eleven nominal Days shall be omitted and that which would have been the third shall be reckoned & Esteemed the fourteenth day of the said month, & that which would otherwise have been the fourth day of the said month must be deemed the Fifteenth, & so on. It appears likewise necessary that Friends should conform themselves to this direction and omit the Eleven nominal days accordingly."

"Business being Ended, The Meeting adjourned to Burlington on the 24th day of the Ninth Month in the next Year according to this new Method of Computing of Time, which will be on the Second First day of the Week, in the month by Law called September.

Extracted & Examined  
by  
ISR. PEMBERTON,  
*Jun' Clk."*

According to both the Julian and Gregorian calendars, January has always been January, but to change the eleventh month to the first, and the twelfth to the second is making "confusion worse confounded," particularly to genealogists who wish to reduce dates of births and deaths from old style to new.

It may be difficult for some persons to understand the last paragraph of the preceding "Extracts," how the 24th of the Ninth Month (September) could be the Second First day of the week (Sunday) occurring in the month. It must be remembered, that the last day of Old Style was Wednesday, the 2d, and the first day of New Style, the next day, Thursday, the 14th of September (or Ninth Month), the change only affecting the numerical order of the days of the month, the names of the days of the week continuing as though no alteration had been made; consequently the first Sunday (or First day of the week) in the month happened on the 17th, and the second on the 24th; the month, by the dropping of 11 days, consisting of 19 days only.

#### ECCLESIASTICAL AND HISTORICAL YEAR.

In England, as early as the 7th century, the year began on the 25th of December, or Christmas day, and this date was used by most persons until the 13th century. But in the 12th century, the Anglican Church required that their year should commence on the 25th of March (Annunciation, or Lady-Day). This rule was adopted by the Civilians in the 14th century, and was adhered to until 1752. It was known as the Ecclesiastical, Legal, or Civil year. The 1st of January, however, has been considered as the beginning of the Historical year from the time of the Conquest, A. D. 1066, and in Scotland from A. D. 1600. This difference caused great practical inconvenience, and consequently double-dating was usually resorted to, for time between the 1st of January and the 25th of March, thus: February, or 12th mo. 6th 168 $\frac{1}{2}$ , or 1684-5, as we often find in old records. This date in New Style would correspond to February, or 2d month, 16th, 1685, the lower last figure representing the Historical year, according to our present mode of computation, commencing with the 1st of January; and the upper or first figure the Ecclesiastical or civil year, beginning with the 25th of March. Without this method of double-dating it would be difficult to know which year was intended, particularly for time between the 1st and 25th of March. There are instances, however, in which double-dating for

the above months was not used; in such cases the year, as given, must be taken as commencing on the 1st of January. This system was adopted, occasionally, in each country earlier than the Gregorian or New Style.

In changing the days of the month from old style to new, add to them the figures 9, 10, 11, or as the case may be in the respective periods of the preceding table; always remembering that in the numerical arrangement of the months, the First month represented March, and so on, previous to the year 1752 in Great Britain and her colonies.

It is, however, particularly recommended, that dates should not be changed, in any case, but that the letters O. S. be added, when necessary. This will relieve Historians, and others, from much perplexity, as they can make their own calculations †

#### DOMINICAL LETTERS.

It is sometimes of the greatest importance that we should know on what day of the week a certain event took place (or may happen in the future), or, having the day of the week, what day of the month will correspond to it. Numerous intricate methods of calculation have been suggested at various times for solving this difficulty. The use of the following table will save all that trouble and waste of time, and a few minutes' attention will make any person perfectly familiar with it.

The first seven letters of the alphabet, A, B, C, D, E, F, G, have been employed by chronologists to designate the several days of the week, the first letter standing for the first day of January, and so on, and since one of these letters must necessarily stand opposite to Sunday, it is called the Dominical or Sunday letter. When January begins on Sunday, the dominical letter for that year is A, and, as the common year consists of 52 weeks and 1 day, the year must begin and end on the same day of the week; and the next year must begin on Monday, therefore Sunday will be the seventh day, and the letter G will be the dominical letter. The third year will begin on Tuesday, and, as Sunday falls on the sixth day, F will be the dominical letter. Hence it follows that the dominical letters will succeed each other in a retrograde order, viz., G, F, E, D, C, B, A, and if there was no leap-year, the same day of the week would, in the course of seven years, return to the same days of the month. But since a leap-year contains 52 weeks and 2 days, any leap-year beginning on Sunday will end on Monday, and the following year will begin on Tuesday, the first Sunday of which must fall on the sixth day of January, to which the dominical letter F corresponds, and not G, as in common years. As the leap-year returns every fourth year, the regular succession of the dominical letter is interrupted. Its next recurrence can be found by dividing the year by 4 (see example below, with the dominical letter F; the lower figures representing the remainders), if there be no remainder, the interval to the next year will be 6 years; if 2 remain it will be 11 years; if 1 remain it will be 6 years, and if 3 remain the interval will be 5 years.

|         |          |         |         |         |          |         |        |
|---------|----------|---------|---------|---------|----------|---------|--------|
| GF.     | F.       | F.      | F.      | GF.     | F.       | F.      | F.     |
| 1844+6= | 1850+11= | 1861+6= | 1867+5= | 1872+6= | 1878+11= | 1889+6= | 1895+5 |
| 0       | 2        | 1       | 3       | 0       | 2        | 1       | 3      |

The cycle of recurrence is, therefore, 6, 11, 6, 5, except as modified by the centesimal years.

I have been thus explicit, as I cannot find that any writer has mentioned the above fact. They all appear to be unanimous in the statement, that the Solar Cycle, a period of 28 years, is the *only* time when the same days of the week will correspond to the same days of the month. Previous to the change of style in 1752, 28 years always

† A work entitled "Memorials of John Bartram and Humphrey Marshall," Philadelphia, 1849, furnishes a case in point. It is devoted almost exclusively to a correspondence between members of the Society of Friends, in the early part of the last century, who used the numerical order of dating, beginning the year with the 1st month, or March. The editor has changed this, by naming the first month January, and consequently has dated a greater part of the letters two months before they were written, and births and deaths two months before they occurred. This is certainly a new style, and not uncommon among our younger genealogists.

elapsed between any two leap years having the same dominical letters, but since that time the rule will answer only for the leap-years of each century separately.

Immediately above, or preceding every leap-year in the table, there is a blank space, and in a line with it, under the century, will be found the dominical letter that must be used for the months of January and February, and in a line with the year, the letter to be used for the remainder of the leap-year; thus 1876 has B and A, 1880 D and C, 1884 F and E, etc. This, with the explanation at the top of the table, should enable anyone to prove its accuracy by

comparison with almanacs, either in the old or new style, or with books and newspapers. §

The year 1752, on account of the change of style, had three dominical letters. E from Wednesday, January 1st, to Saturday, February 29th; D from Sunday, March 1st, to Wednesday, September 2d; and A from Thursday, September 14th (when New Style was adopted), to close of the year.

§ A table similar to this, but not so extended, appeared in the N. E. Historical and Genealogical Register, vol. xx. 1866. It was communicated by Isaac J. Greenwood, of New York.

| Explanation.—Look for the Century, then to the right or left for the year, and in a line with the latter, directly under the Century, is the Dominical letter for the year. |    |    |    |    |    |    |    |  |  | CENTURIES. |      |      |      |      |      |      |           | Then in the Calendar, in the lower part of the table, find the day of the month, and in a line with it, under the given Dominical Letter, you have the day of the week; or <i>vice versa</i> . |        |    |    |    |    |    |  |  |  |  |
|---|----|----|----|----|----|----|----|--|--|------------|------|------|------|------|------|------|-----------|--|--------|----|----|----|----|----|--|--|--|--|
| YEARS.  |    |    |    |    |    |    |    |  |  | Old Style  | 0    | 100  | 200  | 300  | 400  | 500  | 600       | Old Style  | YEARS. |    |    |    |    |    |  |  |  |  |
|   |    |    |    |    |    |    |    |  |  |            | 700  | 800  | 900  | 1000 | 1100 | 1200 | 1300      |  |        |    |    |    |    |    |  |  |  |  |
|   |    |    |    |    |    |    |    |  |  | 1400       | 1500 | 1600 | 1700 |      |      |      | New Style |  |        |    |    |    |    |    |  |  |  |  |
|   |    |    |    |    |    |    |    |  |  | 1700       |      | 1800 |      | 1900 | 2000 |      |           |  |        |    |    |    |    |    |  |  |  |  |
|   |    |    |    |    |    |    |    |  |  | 2100       |      | 2200 |      | 2300 | 2400 |      |           |  |        |    |    |    |    |    |  |  |  |  |
|   |    |    |    |    |    |    |    |  |  | 2500       |      | 2600 |      | 2700 | 2800 |      |           |  |        |    |    |    |    |    |  |  |  |  |
| 0   | 6  | 17 | 23 | 28 | 34 | 40 | 45 |  |  | C          | D    | E    | F    | G    | A    | B    | 51        | 56   | 62     | 68 | 73 | 79 | 84 | 90 |  |  |  |  |
| 1   | 7  | 12 | 18 | 29 | 35 | 41 | 46 |  |  | B          | C    | D    | E    | F    | G    | A    | 52        | 57   | 63     | 69 | 74 | 80 | 85 | 91 |  |  |  |  |
| 2   |    | 13 | 19 | 24 | 30 | 36 | 42 |  |  | A          | B    | C    | D    | E    | F    | G    | 53        | 58   | 64     | 70 | 75 | 81 | 87 | 92 |  |  |  |  |
| 3   | 8  | 14 | 20 | 25 | 31 | 37 | 43 |  |  | G          | A    | B    | C    | D    | E    | F    | 54        | 59   | 65     | 71 | 76 | 82 | 88 | 93 |  |  |  |  |
| 4   | 9  | 15 | 21 | 26 | 32 | 38 | 44 |  |  | F          | G    | A    | B    | C    | D    | E    | 55        | 60   | 66     | 72 | 77 | 83 | 89 | 94 |  |  |  |  |
| 5   | 10 | 16 | 22 | 27 | 33 | 39 | 44 |  |  | E          | F    | G    | A    | B    | C    | D    |           | 61   | 67     | 73 | 78 | 84 | 89 | 95 |  |  |  |  |
| 5   | 11 |    |    |    |    |    |    |  |  | D          | E    | F    | G    | A    | B    | C    |           |  |        |    |    |    |    |    |  |  |  |  |

| MONTHS.                    |    |    |    |    |   |    |    |      |      | DOMINICAL LETTERS. |      |      |      |      |      |    |            | MONTHS. |    |    |    |                               |    |    |  |  |  |
|----------------------------|----|----|----|----|---|----|----|------|------|--------------------|------|------|------|------|------|----|------------|---------|----|----|----|-------------------------------|----|----|--|--|--|
| January 31.<br>October 31. |    |    |    |    | February 28.<br>March 31.<br>November 30. |    |    |      |      | A                  | B    | C    | D    | E    | F    | G  | August 31. |         |    |    |    | September 30.<br>December 31. |    |    |  |  |  |
| 1                          | 8  | 15 | 22 | 29 | 5   | 12 | 19 | 26   | S    | Sa.                | Fr.  | Th.  | Wed. | Tu.  | Mon. | 6  | 13         | 20      | 27 | 3  | 10 | 17                            | 24 | 31 |  |  |  |
| 2                          | 9  | 16 | 23 | 30 | 6   | 13 | 20 | 27   | Mon. | S                  | Sa.  | Fr.  | Th.  | Wed. | Tu.  | 7  | 14         | 21      | 28 | 4  | 11 | 18                            | 25 |    |  |  |  |
| 3                          | 10 | 17 | 24 | 31 | 7   | 14 | 21 | 28   | Tu.  | Mon.               | S    | Sa.  | Fr.  | Th.  | Wed. | 8  | 15         | 22      | 29 | 5  | 12 | 19                            | 26 |    |  |  |  |
| 4                          | 11 | 18 | 25 | 8  | 15  | 22 | 29 | Wed. | Tu.  | Mon.               | S    | Sa.  | Fr.  | Th.  | 9    | 16 | 23         | 30      | 6  | 13 | 20 | 27                            |    |    |  |  |  |
| 5                          | 12 | 19 | 26 | 9  | 16  | 23 | 30 | Th.  | Wed. | Tu.                | Mon. | S    | Sa.  | Fr.  | 10   | 17 | 24         | 31      | 7  | 14 | 21 | 28                            |    |    |  |  |  |
| 6                          | 13 | 20 | 27 | 10 | 17  | 24 | 31 | Fr.  | Th.  | Wed.               | Tu.  | Mon. | S    | Sa.  | 11   | 18 | 25         | 1       | 8  | 15 | 22 | 29                            |    |    |  |  |  |
| 7                          | 14 | 21 | 28 | 11 | 18  | 25 |    |      |      |                    |      |      |      |      | 12   | 19 | 26         | 2       | 9  | 16 | 23 | 30                            |    |    |  |  |  |

| April 30. |    |    |    |    | May 31. |    |     |      |      | A    | B   | C    | D    | E    | F    | G  | June 30. |    |    |    |    | July 31. |    |    |  |  |
|-----------|----|----|----|----|---------|----|-----|------|------|------|-----|------|------|------|------|----|----------|----|----|----|----|----------|----|----|--|--|
| 2         | 9  | 16 | 23 | 30 | 7       | 14 | 21  | 28   | S    | Sa.  | Fr. | Th.  | Wed. | Tu.  | Mon. | 4  | 11       | 18 | 25 | 2  | 9  | 16       | 23 | 30 |  |  |
| 3         | 10 | 17 | 24 | 8  | 15      | 22 | 29  | Mon. | S    | Sa.  | Fr. | Th.  | Wed. | Tu.  | 5    | 12 | 19       | 26 | 3  | 10 | 17 | 24       | 31 |    |  |  |
| 4         | 11 | 18 | 25 | 9  | 16      | 23 | 30  | Tu.  | Mon. | S    | Sa. | Fr.  | Th.  | Wed. | 6    | 13 | 20       | 27 | 4  | 11 | 18 | 25       |    |    |  |  |
| 5         | 12 | 19 | 26 | 10 | 17      | 24 | 31  | Wed. | Tu.  | Mon. | S   | Sa.  | Fr.  | Th.  | 7    | 14 | 21       | 28 | 5  | 12 | 19 | 26       |    |    |  |  |
| 6         | 13 | 20 | 27 | 11 | 18      | 25 |     |      |      |      |     |      |      |      | 8    | 15 | 22       | 29 | 6  | 13 | 20 | 27       |    |    |  |  |
| 7         | 14 | 21 | 28 | 12 | 19      | 26 | Th. | Wed. | Tu.  | Mon. | S   | Sa.  | Fr.  | 9    | 16   | 23 | 30       | 7  | 14 | 21 | 28 |          |    |    |  |  |
| 1         | 8  | 15 | 22 | 29 | 13      | 20 | 27  | Fr.  | Th.  | Wed. | Tu. | Mon. | S    | Sa.  | 10   | 17 | 24       | 1  | 8  | 15 | 22 | 29       |    |    |  |  |
|           |    |    |    |    |         |    |     |      |      |      |     |      |      |      | 11   | 18 | 25       | 2  | 9  | 16 | 23 | 30       |    |    |  |  |

(To be continued.)

Apertures of the Principal Telescopes.

WE BORROW the following remarks from an article in the *Revue Scientifique* on the progress of telescopes as regards size, in which it gives a list of large refracting telescopes, which we have corrected, down to 15 inch.

At the end of the 18th century Herschel gave a very great impulse to physical astronomy. His amazing manual dexterity, his activity, his patience, led to the great works which made of him one of the greatest minds that England ever possessed. Guinand and Franhofer led to the realization of large objectives by the progress they instituted in the manufacture of optical glass, while a mechanism of clockwork compelled the glasses and telescopes to follow the diurnal movement of the stars. All modern instruments are mounted in this manner. The tendency is toward enlargement, so that telescopes have reached such a size that some possess mirrors 1.20 meters in diameter (Paris and Melbourne), with refractors 0.65 meter aperture (Washington), of 0.75 meter, and even one meter in diameter. Is this mania for enlargement justified? Arago, when he asked from the Chamber the credit necessary for the construction of an objective of

0.38 meter, believed that, by raising the enlargement of the glasses to 6,000 times, objects upon the moon 20 meters in length or 2 meters in width should be seen, the causeway of a railroad, fortifications and monuments. The single difficulty in the way of realizing this hope lies in the deficient luminosity of the images. It is yet impossible to determine to what extent the increase of the optical power of a lens or of a telescope is more that compensated by the increase of spherical aberration, the difficulty of manipulation, the instability, and deficiency of light. To give a more exact conception of the fineness of details that are attained in a good instrument, we may recall that Schiaparelli, in his observations upon Mars, made at Milan, with a lens of Merz, of 0.218 meter aperture—Mars being distant 14 million leagues during the opposition of 1877—could distinguish a round spot 137 kilometers wide. From Mars an island such as Sicily, a lake of the size of Lake Ladoga or Tshad, could have been seen, a zone of 70 kilometers (1 kilometer = 1093.7 yards or 0.62138 mile) would have been visible, and Jutland, Cuba or Panama would have been seen. The lens at Washington, 0.65 meter, would show details but one-third the size, that is 44 to 24 kilometers; upon the

moon the lowest dimensions would be 315 meters in size, upon the sun 177 kilometers, upon Venus 36 kilometers, upon Jupiter 555 kilometers. Experience proves that the most useful aperture is from 0.38 meter to 0.40 meter.

The following is a table of instruments of which the greatest diameter is 0.92 meter. The number of lenses whose diameter is greater than 0.245 meter does not exceed 60.

| Observatory.                 | Aperture<br>in<br>Centimeters. | Maker.               |
|------------------------------|--------------------------------|----------------------|
| Lick, in California,         | 91.5                           | Clark & Son.         |
| Pulkowa,                     | 76.0                           | Clark & Son.         |
| Nice,                        | 76.0                           | Henry Bros.          |
| Paris,                       | 73.5                           | Martin.              |
| Vienna,                      | 68.5                           | Grubb, 1881.         |
| Washington,                  | 66.0                           | Clark, 1873.         |
| McCormick, Chicago,          | 66.0                           | Clark, 1879.         |
| Newald, Gateshead, England,  | 63.5                           | Cook & Son, 1868.    |
| Princeton, N. J.,            | 58.5                           | Clark, 1881.         |
| Strassburg,                  | 48.5                           | Merz & Mähler, 1879. |
| Milan,                       | 48.5                           | Merz, 1881.          |
| Dearborn, Chicago,           | 47.0                           | Clark, 1863.         |
| Vander Zee, Buffalo, N. Y.,  | 46.5                           | Fitz.                |
| Rochester,                   | 40.5                           | Clark, 1880.         |
| Madison,                     | 39.5                           | Clark, 1879.         |
| Dun Echt,                    | 39.5                           | Grubb, 1875.         |
| Royal Society (Dr. Huggins), | 39.5                           | Grubb.               |
| Pulkowa (smaller),           | 39.5                           | Merz & Mähler.       |
| Harvard College, Mass.,      | 39.5                           | Merz & Mähler.       |

The observatory at Lisbon has a telescope with an aperture of 14.8 in., and there is in course of construction (the above are not all quite finished) a telescope of 28 in. or 29 in. (71 to 74 centimeters) for Yale College, by Clark & Son.

### The Engraving of Gems.

THE ART of engraving gems is very old. Due to the extraordinary hardness and durability of these small works of art, thousands of years have passed by and left them unscathed, and they have been transmitted to us, materially aiding the student in his researches of the mythological and heroic ages. Chinese engravings represent characters which the present generation no longer understands, and thereby they become monuments of a prehistoric civilization. Egyptians, Babylonians, Greeks, Romans—in fact all ancient nations with whom we are acquainted—have, from the earliest time up to their decay, left to us a record of their rise and fall by means of these gems. Moses specifies what class of engraved gems the vestments of the high priests shall bear. Herodotus is the first author who mentions the name of an engraver of gems (Theodoros). Later engravers—for instance, Pyrgoteles, the favorite of Alexander the Great; Dioskurides, living in the time of Augustus, and several others—are better known. But it was not alone self-vanity that prompted the wearing of these engrossed stones as articles of personal adornment, nor the love of art to possess them, that caused them to be produced; it was rather the superstition that engraved stones possessed eminent secret virtues. They were worn as protectors against sickness, as intercessors with Deity, etc.—a superstition which was transplanted even into early Christendom, and combatted by the early bishops of the church. The art of gem engraving fell into complete decay with the fall of the Roman Empire, and continued to be practiced only in Byzantium until this city was taken by the Turks, when several of the gem engravers living there took refuge in Italy and transplanted the art to its shores, where, under the protection of several art-loving Popes and the Medicis, it soon began to flourish.

To the most excellent masterpieces of this kind belong the works

of the Pichlers, senior and junior, a family which in the eighteenth century emigrated from Tyrol and settled in Italy. Joseph II. ennobled the son, and his bust was placed in the Pantheon. King Frederick William III., of Prussia, endeavored to introduce the art in his kingdom. He caused a gem engraver—Calandrelli, of Rome—to settle in Berlin and to teach scholars, but the king remained to be the sole promoter, and the scheme met with no favor by the people. Calandrelli profited by the ignorance of the people, and through agents sold his products to the Royal Museum of Berlin as specimens of antique Greek engraving. It was no wonder, therefore, that the few scholars taught by him either left the art altogether, turned engraving into a trade vocation, or settled in foreign countries; and, beside the engraving of a seal or a coat of arms, little in this line is at present done in Prussia.

Much greater success than Calandrelli had at Berlin was met by another Italian in Paris, who settled here in the beginning of this century. He found very ready assistance in all circles, and a respectable number of scholars soon gathered around him. Under the reign of Napoleon III. there were several ateliers with from ninety to one hundred and twenty engravers, and, in all, there were several thousand artists working in this art branch in Paris, which had become the world's mart for these productions, while the export amounted to several millions of francs annually. The Ecole des Beaux Arts yearly turns out a respectable number of "medailleurs" and gem engravers, who receive their artistic training under the same conditions as painters and sculptors, and the *salon* every year exhibits a number of engravings of a rare artistic merit.

Germany also has two places where this art supports from three to four hundred followers. We speak of Idar and Oberstein, which, beside this, contain the largest jewel cutting establishments in the world. These artists are complete dependents upon Paris as the only market where they can dispose of their products, and for this reason they were compelled to obey the mandate of their Parisian customers not to expose their goods at Melbourne. It is rather singular that, although the Germans are the masters of the art, both at home and in Paris, a German, "Pichler," executed the best works in Italy, that many Germans in Paris have executed the best masterpieces there, and their works fill the *salon*. Nevertheless, the art is looked on as eminently French, and the productions of the Germans go into the world as French.

Together with many other erroneous beliefs, there is one which holds that, if a gem engraver of the present day has only approached the productions of antiquity, he is a master of his art. This is altogether untrue. There are only a few of the best Greek engravings, especially the larger portraits, heads, busts, etc., that may be called artistic. Technically considered, modern works are higher finished, because only the invention and use of the magnifying glass made the correct finishing, especially that of the smallest and most delicate pieces possible. Not one of the many antique gems contained in the European museums shows in its minor details the pronounced expression and correct finish of the modern gem cut since the seventeenth century. The ill success of Calandrelli, which is not sole of its kind in history, conclusively proves that there is a superabundance of false beliefs even in scientific circles, and that their so-called expert judgment is frequently influenced by prejudice; work is often pronounced to be bad because it is modern, and surpassingly beautiful because deemed to be antique.

Many antique engravings are known to us only through glass pastes. They are produced by running melted glass, of the color of a gem, over the plaster of paris impression of a gem. When cold, the glass is retouched and reduced into the shape of the original. These duplicates assume pretty sharp contours, and if carefully done they can barely be distinguished from real engraved gems; many frauds have been perpetrated with them; glass plates of barely any value have frequently been sold as genuine gems.

The student will sometimes see in scientific books that the ancients also engraved on glass. This is another erroneous belief, and gotten



up at first, perhaps, for the purposes of fraud and deception. No artist will make use of glass for artistic purposes of this nature; first, because it is cut with greater difficulty than a gem, and therefore would require a longer time; and, second, it cannot be used for sealing, because it heats at once and remains sticking to the wax.

## Practical Treatise on the Adjustment of a Four-Jewel Cylinder Watch.

[First-Prize Essay by HERMANN HORMANN.]

*Continued from page 170.*

255. After you are fully satisfied that the spring hooks in well, has at least five coils, and that it unwinds without friction, the male stop is mounted by winding the spring and leaving one-half coil, which, after mounting the stop, can no longer be wound, wherefore the spring, after running down, always remains wound one-half coil.

Brass wire is well suited for a fastening pin, because brass easily accommodates itself to the hole and therefore fits more firmly. It is put in from the side of the stop, with which it then, in winding, braces against the female stop, and it must on no side project beyond the male stop.

Should it be necessary that the pin has to be filed unduly thin, it is better to make a steel pin.

256. It should be remembered that parts like the barrel should never be brushed after they have been lubricated for the purpose of removing finger marks. The barrel is smeared up thereby and the gilding injured, so that another dismounting and cleansing of the parts become necessary. Should small spots have been caused by handling it is well to take a linen rag, free from fiber, lay it over the right forefinger, dip it in benzine and pass it over the offending places.

257. Next mount the barrel and screw down the bridge. Wind up the length of a few ratchet teeth and observe the vibrations of the balance in various positions. To enable you to observe it also on the opposite side, that is with the dial on top, hold the movement over a mirror. Should differences of rate become noticeable in this position, seek at once for the provocations and correct them. Oil is then applied to the upper fourth and third wheel hole, as well as to the three lower holes, and the movement is then fastened in the case.

258. After having slightly moistened the minute-wheel pin with the point of a pegwood the minute work is mounted. Should it be necessary to introduce a spreading spring underneath the dial, on account of giving sufficient shake to the hour wheel, it is never to be omitted, but the brass foil must be made as thin as possible.

259. After this it is necessary to press the seconds hand upon its pivot in order to examine whether it possibly will scrape upon the bottom of the sink with the end of its canon; if it does, shorten the canon.

The dial is then cleaned with a clean rag or silk paper, next mounted and fastened. Now clean the hands, mount the seconds hand first, paying attention that it moves free above the dial, and after this the hour and minute hands.

260. By a continued turning of the hands, especially above the little seconds dial, assure yourself that the three hands pass above each other with the required space, and, if necessary, bend them correspondingly. The point of the minute hand is always adapted to the shape of the crystal, and is invariably bent downward, so that it cannot scrape on the crystal; it is to be bent as soon as the movement is mounted in the case. Again examine that the little caps are not pressed aside by the dust cap.

After having cleaned the crystal within, removed all and any dust from the dial, closed the bezel and wound the watch set the hands by the regulator, and close the case to regulate the watch.

## CHAPTER XX.

### THE REGULATING.

261. In order to quickly regulate the watch, after having adjusted it, count its vibrations. It is necessary for this to know whether the watch has been arranged to make 18,000 beats per hour.

It is to be calculated in the following manner: Supposing that the center wheel has 64 teeth, the third wheel 60, the fourth wheel 60, the scape wheel 15; the number of wheel teeth are to be multiplied together, and then with 2, after which the sum is to be divided by the number of pinion leaves.

$$\frac{64 \times 60 \times 60 \times 15 \times 2}{8 \times 8 \times 6} = 18,000.$$

This result is divided by the minute.  $18,000 : 60 = 300$  vibrations, of which only the double vibrations are counted, or 150.

262. The watch is held against the ear while observing the seconds hand of the shop timepiece. As soon as its seconds hand points at 60 the counting of the vibrations of the watch is commenced, and continued until the seconds hand again arrives with the last pendulum beat at 60. If it was more than 150 the watch goes too fast, and the regulator has to be moved to "slow;" if, however, the number of beats is less, the regulator is advanced, and counting commenced anew. With very small differences great pains must be taken to correctly start and stop counting, and it is advisable to continue it for 2 or 3 minutes, until a difference is no longer noticed.

263. The seconds hand of the watch is then set with that of the regulator, after which the watch is laid on the bench. The adjuster can fully satisfy himself in the space of 12 minutes whether the watch differs. This difference in seconds in these 12 minutes amounts to as much as if the watch in 12 hours differed the same quantity in minutes. For instance, if this difference amounted to 2 seconds acceleration the difference in 12 hours is 2 minutes.

With watches without seconds hand a small dot is made upon the fourth wheel with a pointed tool, then move the wheel until the dot disappears underneath the scape wheel; wait until the seconds hand of the regulator points at 60 and let the former go. It is easy to estimate a difference of 5 seconds in 24 minutes in this manner.

264. The regulator index of a regulated watch must not be pushed beyond the bridge, and the most proper place would be at "slow," or a little more in the center. Should the index stand otherwise when the watch goes correct it is necessary to draw out, that is, lengthen the spring a little, if the watch gains, and in the contrary case the spring is to be shortened. No definite rules can be given, as one watch varies from the other in this particular.

Should, however, the regulator index stand at "fast," imagine a straight line, intersecting the jewel hole, to be drawn upon the lower side of the bridge, and starting from "slow." The space between this line and the index placed at "fast" must be imagined as transported in proportion upon the last coil, and this piece would have to be drawn through. When now the regulator is again moved to "fast" the watch will go right. It is necessary, however, to lay the balance spring in such a manner again that the last coil moves free between the curb pins, and the collet is truly centered over the jewel hole, so that the balance spring exerts no side pressure upon the pivots.

Should the watch lose very much, and the balance spring be a small one, it is advisable to correct it by breaking away a piece from the inner coil, which is far more effective than changes on the outer. In no case must such a quantity be broken away that there is an empty space around the collet, because such a balance spring would be unfit for close regulating. It is to be replaced by a new and more suitable one.

If, on the other hand, the watch gains so much that nothing more of the spring can be drawn out, it is too strong for the movement, and a weaker one must be put in.

265. A good assortment of springs is to be kept on hand, which are packed in separate packages according to size and strength.

First pick out an approximately correct size of spring, by taking

out one which it is believed might suit, push about one-fourth coil through the stud and lay it between the curb pins to see whether the inner coil lies exactly above the jewel hole.

If the spring is either too large or too small try another number until you have found one of fitting size. Next pay attention to the strength. For this purpose compare the new spring with the old one by seizing each one at the last coil and passing the first inner coil into the small notch of the cylinder and drawing it upward. The cone formed in this manner by the new spring must be a little longer than that of the old.

Having found the approximate strength fasten the inner coil with a little wax to the upper collet of the cylinder, with the tweezers seize the last coil of the spring, and while lightly resting the lower pivot upon a glass plate permit the balance to vibrate.

266. Count the vibrations, as was described in Art. 262, or hold a correctly going watch to the ear; of course it is to be one making the same number of beats per second, and you will ascertain with ease whether the beats of the watch will be in unison with those of the balance. If this is not the case, seize the balance spring either longer or shorter, in accordance with whether the balance vibrates too slow or too quick.

If you are unable to obtain the same number of beats with this spring take either a higher or a lower number, according to the difference, until you have found a suitable one. Having found it, put it in beat by seizing it with the tweezers forward or backward, and there where its vibrations concur with those of the standard watch or timepiece is the place where the spring must lie between the curb pins, after which it is fastened and the regulator is moved to "slow."

267. The pin used for fastening the last coil in the stud must be filed flat on the side turned to the spring, so that the blade of the latter be not pressed hollow on that side, whereby an exact regulating is rendered impossible, in case the balance spring would have to be lengthened. With a little practice a spring can be chosen in this manner which, in 24 hours, barely varies five minutes.

268. When the watch goes correct when laid flat proceed to regulate it in the positions.

It is not the purpose of this little treatise to enter into the details of close regulating, but simply to point out a few methods employed by many watchmakers for regulating watches for ordinary use, and which have been adopted as being practical.

269. When an ordinary cylinder watch has been regulated closely in a horizontal position, it is frequently the case that it differs when suspended, and goes too slow. The reason for this is generally that the friction of the pivots while the watch is lying is less than when the latter is suspended, which may also be due to a rough and thick jewel hole or oval pivots and holes. Beside this, the adhering of the oil to these fine parts is of great importance. This accelerating may be corrected by flattening or making flat altogether the cylinder pivot upon which the watch is supported in lying.

Should the watch gain nevertheless in lying it becomes necessary to mount other and thinner jewel holes, on the sides of which the pivots are exposed to less friction.

270. It is a rare case, perhaps, that a watchmaker will with an ordinary cylinder watch enter into such elaborate work, as the remuneration stands in no proportion to the trouble occasioned. It frequently happens that after a great expenditure of time and labor the watch cannot be closely regulated, and the last resource will be to destroy the equipoise of the balance.

If the watch goes exactly correct when lying and loses when suspended, take out a very little above from the balance there where it stands nearest to the stem when the spring and the balance are at rest, and do the same from below in case the watch should lose in lying. Take great care not to remove too much, otherwise it would become necessary to also remove a trifle from the other side, whereby the balance would be made unnecessarily light.

271. Although this method is rather questionable, because a watch

carried in the vest pocket frequently assumes other positions than that with the XII above; nevertheless I have obtained favorable results therewith. I regulated an ordinary cylinder watch in this manner and it goes so well that it does not vary 1 minute in two weeks.

It must ever be the watchmaker's chiefest aim to correct and improve the rate of every watch, not alone those of a costly kind, but even ordinary ones, because also this latter class of watches is grateful and will reward the pains bestowed upon them by going correct. The value of a watch consists simply and alone in its continued correct rate, not of its outward appearance.

[THE END.]

### The National Association of Commercial Travelers.

IN THE CIRCULAR of last month we called attention to the proceedings of a convention of commercial travelers held at Detroit. The chief business transacted was the adoption of a vigorous protest against the special licenses that some States require commercial travelers to take out, and a report of a committee upon the subject of railroad transportation. On July 8th a large representation of the members of the National Association of Commercial Travelers attended the annual meeting of that body held in Boston at the Merchants' Association rooms. Delegates were present from all over the country, even California being represented. President M. B. Cole, of the firm of Burrage, Cole & Weeks, of New York, occupied the chair, and Mr. J. Will Page, of Syracuse, acted as secretary. After some routine business had been disposed of, Mr. Thomas A. Young, of New York, reported for the Committee on Railroads progress, and predicted within a few months a wholly satisfactory arrangement between the roads and the travelers. He stated that in New York the Traders and Travelers' Union, with a capital of \$200,000 and a membership of the the most enterprising merchants of the metropolis, is co-operating with the Travelers' Association in its endeavors to get more satisfactory arrangements with the railroad companies.

Mr. James T. Eaton offered the following resolutions, which were adopted:—

*Whereas*, Certain cities and States in these United States have upon their statute books and are enforcing certain discriminating and excessive licenses and tax laws against commercial travelers from other States and cities; and

*Whereas*, It is clearly unconstitutional for any State or municipality to enforce said discriminating laws; therefore, be it

*Resolved*, That the National Association of Commercial Travelers of the United States do most earnestly protest against the passage or enforcement of any such laws.

*Resolved*, That so far as the exchange of produce, manufactured articles or merchandize is concerned between the different locations of these United States, we are most emphatically for free trade.

*Resolved*, That we cannot see the wheels of commerce clogged by these license and tax laws without putting ourselves on record as opposed to the whole system, and in order to work systematically for the abrogation of these said laws, be it resolved that a committee of three (to be called the Legislative Committee) be appointed by the convention, whose duty it shall be to communicate with the Senators and Representatives in Congress in reference to such legislation as the exigencies of the case require.

*Resolved*, That this committee be instructed to carry out such means for effecting legislation in the interests of commercial travelers as may seem to them best, and that the members of this association pledge themselves to assist and aid in all honorable measures which may be instituted by Boards of Trade, Chambers of Commerce, and similar bodies and associations looking to this end.

*Resolved*, That this Association strongly favors the bill introduced by the Hon. Mr. Brewer in this interest, and also the amendment to the District of Columbia Police bill introduced by the Hon. C. R. Skinner, of New York, and so ably assisted by the Hon. S. S. Cox and Frank Hiscock, of New York, and the Hon. J. S. Robinson, of Ohio.

The several associations of commercial travelers seem all to have the same objects in view, viz., the repeal of the obnoxious license laws in the different States, and the perfecting of arrangements with the various lines of transportation in accordance with which commercial travelers shall have special advantages over those who travel but seldom. The associations include in their membership many thousands of professional travelers in all lines of trade, and the objects for which they are striving should commend them to the members of the jewelry trade.

---

### How to Prevent Cholera.

THE STATE Board of Health considers the possibility and facilities for the introduction of cholera into this country too obvious to be disregarded, and therefore a memorandum on preventive measures against the disease has been issued. The history of former invasions of cholera, says the board, warrants the belief that its reappearance here is probable. Cholera, which in two months of midsummer in 1865 destroyed 80,000 lives in Egypt, reached France and Germany by September, and was discovered at the New York Quarantine as early as November. In the spring of 1866 it again threatened the United States. It lingered in the West, was returned to Governor's Island, and thence found a new departure in 1867, when it was terribly destructive in some sections. The outbreak in the Mississippi Valley in 1873 was traced to its introduction by way of New Orleans. The disease as reported in Southern Europe presents the same threatening aspects, thinks the board, as it did in August, 1865, when it was conveyed to our shores in a definite manner, and to about the same series of resting places and fatal points of outbreak that it now threatens to attack.

The facilities for the introduction of the disease have increased since 1865, but the means of exact sanitary knowledge and quarantine police for arresting and stamping out the transportable cause of it are also greater. No city which is fully prepared for the announcement that Asiatic cholera has come need be invaded by it if proper sanitary care is exercised. The floods throughout Europe and the United States, the attendant circumstances of the drying period, the increased immigration from the Mediterranean States to New York, and the destructive malignancy of the disease, all give a warning to be ready for Asiatic cholera.

There is, says the State Board, a specific infective cause of Asiatic cholera, called its contagium, by which it spreads as rapidly as the persons suffering, ever so lightly, from it go from place to place. In every country where the contagion exists it has ceased to be repropagated beyond the sanitary lines which separate the cleansed, drained and ventilated premises and well-conditioned inhabitants from the filthy, or where polluted food and water and harmful beverages prepare the system for the fatal operation of the poison. For cholera to be diffused from continent to continent it must have as factors for its cultivation a center of pollution for its cradle, a ship for its transport, and a number of towns prepared for its reception and development. Local conditions of danger—the sanitary neglects that have prepared for a lodgment and repropagation of the cholera in filthy places and sodden grounds—are found in every port, city, and village, and in many rural hamlets. The prevention of propagation is very difficult after the disease has obtained a foothold in any of the commercial centers. The presence of filth, stagnant pools, polluted water, and badly housed and imprudent people will invite cholera to hundreds of places in the State if it once appears in any port. "Now," says the board, "before the exotic infection has come, let all local Boards of Health and all householders lose no time in enforcing such thorough scavenging and cleansing, such cleansing of sewers, drains, and ditches, and such ventilating, drying, lime-washing, and disinfecting of cellars and all damp and unclean places that if cholera comes its infective germs shall find no soil or foul surface in which to propagate epidemically."

The contagion is not chiefly taken from the bodies of the sick, but the virus is proved to require the concurrence of attendant conditions of moisture and filth to produce any extended series of cases. One great source of danger is that the exotic germinal matter becomes not only infective of persons exposed to it by water or the atmosphere, but may, by its infinite rapidity of reproduction, under favoring conditions of foul air and filth, rapidly become epidemic within the limits of such impurity. Sanitary barriers must therefore be erected before cholera comes. As soon as found the disease must be treated by vigorous isolation and destructive disinfection.

Preventive sanitary measures consist in annihilating all local conditions which would harbor the disease. If the cholera germs find no breathing place in filthy condition of premises, air, or drinking water, there is no danger. The memorandum concludes: "Whenever cholera comes, as we hope it will not, a brief statement showing how to resist cholera and what to do in its presence will be immediately sent to all parts of the State through the local Boards of Health. It is now the duty of local sanitary authorities and all householders to inspect the premises within their jurisdiction and promptly cause the necessary sanitary improvements to be made. None of this work will be lost, even were cholera effectually arrested by the barriers of quarantine and disinfection at the ports it enters. The reasons for sanitary inspections and works are applicable to protect against infectious and epidemic diseases generally, and it is because in the midst of wet grounds and pools, filth sodden surfaces, foul sinks, and polluted drinking waters, cholera finds local conditions for its epidemics, that now the general duty is urged upon all sanitary authorities and householders to make careful sanitary inspections; to drain all stagnant pools and low grounds near dwellings; to clean all sewers and house drains; to cleanse and disinfect cellars, privies, and all filthy places, and examine and protect the purity of drinking water."

---

### How Antiquarians Decipher Illegible Writings and Fix Dates.

THE *Kunst und Gewerbe* reports a very interesting find, made a few years ago, in a stone quarry near the village Wittislingen, which lies close to an old Roman highway leading to a crossing of the River Danube. The treasure was found in a deep rock sepulchre, and was purchased by the National Museum at Munich. The *Allg. Zeitung*, which first reported the find, said that it is not alone the precious substance from which these pieces are manufactured, but also their ornamentation and inscription, together with the manner of interment of their possessors—their skeletons were found in the graves—that throw a highly interesting light on the state of the old German culture. The grave contained ornamental plates, rings, capsulas, large head of hair-pin, and ornamental pieces for books; girdle, dresses, and straps, all composed of fine gold and silver, and partly set with a scroll work of Zirconite (or hyacinth), together with a bronze vessel with handle, a shell, and many broken pieces of trinkets, household utensils, bronze and iron weapons, which have decayed with the lapse of years; beside this, was also found a fibula, or dress buckle, which, on account of its size and ornamentations, is perhaps the sole of its kind, and by its inscription solves a very interesting problem. It is perhaps the most interesting piece of personal trinkets that ever was unearthed from a grave of the ancient Germans. The main body is of silver, and upon its right side profusely adorned with gold, gold-plated scroll work and red jewels; upon its underside it bears the inscription, which is filled out with black enamel. How can the writing be interpreted, and what is the epoch of the fibula? These questions have excited the philologists at Munich, and it might be answered as follows: "Uffila vivat in Domino filix inocens funere capta quia vire dum potui fui fidelissima tua in Deo pio." Below it stands upon one side, "via fati," and upon the other "Digerig fet" (fecit). The engraver of this

name added the undeciphered letters, "s . . . o . . . m . . a (or d) . . . t (or f) . . e . . .," and filled the other empty spaces at random with a few signs similar to letters, as was frequently done at that time. Now, the word "fidclis" upon ancient Christian tombstones signifies the faith and piety in belief; "inocens," which occurs as frequently, and which is sometimes corrupted into "inox," a sinless life; "felix" corresponds to our blessed in the Lord; "funere raptus" or "captus" means "suddenly snatched away by death." Wherefore, the inscription upon the fibula, or dress-pin, in which the "vire" is palpably only a barbarian corruption of "vivere," can be interpreted as follows: "Uffila live blessed in the Lord! Sinless have I been snatched away by death; as long as I could live I was the most faithful; thy Tisa, in the Lord." The fibula was undoubtedly the costliest treasure of her house, and the widow, foreseeing her rapid death and reunion with her husband in the grave, ordered that her dearest treasure be inscribed accordingly, afterward to accompany her into the common grave. The engraver, Digerig, added his name and the superfluous admonition "the way of fate," together with the other letters. Perhaps he even formed a Græco-Latin word, "somate," in order to say, "Thus it goes in this life." The date of origin of this trinket, however, is first of all proved by the place of burial; this was a lonely grave, cut deep into the rock. If the neighborhood had been entirely Christian at that time, then the common churchyard would most assuredly have been used as place of burial. For this reason, the eighth or ninth century is decidedly too late. The style of ornamentation, as well of the fibula itself as of the other pieces, clearly pertains to the old Germanic time. In common with these, we find ox-head, projections and scroll work, with serpents' heads on the oldest utensils of this kind of Germanic times, specimens of which have been dug from the graves of the Visigothic King Theodorich, who fell in the great battle of the Huns, in the year 451, and of the Frankish King Chilperich, who was buried in 481 at Doornik (Tournay), and are given in Peigne de la Court's work on the place of the Attila battle. The ring with the head is similar to that of Chilperich; the ornamentation of the plate and capsula resemble Etruscan and Græco-Roman types. Most decisive of all for fixing the time is the lettering. This is entirely the same as has been found upon many Christian tombstones bearing Germanic masculine and feminine names. Their erection is generally placed into the time of the Merovingians. But when we compare the style of writing, as found in old documents of this age, the difference becomes visible at once. While the Merovingian round hand is ugly and interlaced, and the book writing rounds into "italics," the writing upon those tombstones retains the full vigor of the Roman squares, and the difference is still more pronounced in the vowels. Wherefore, the tombstones, the writing upon this fibula and its manufacture undoubtedly pertain to the third or fourth century, etc.

---

## The History of Goldsmithing.

*Continued from Page 185.*

TO THE former is devoted a large part of the eighteenth song of the Iliad. The infinite number of objects on the buckler, and figures moving thereon, according to Homer, have caused many critics to simply consider it a poetic fiction.

Whether it ever existed or not, the goldsmith has principally to do with the variety of metals—gold, silver, copper, iron, tin—which Homer says entered into the composition of the buckler. This presupposes an appreciation of contrast, a knowledge of alloys, and of soldering, engraving, and chasing. These the poet could not invent.

It is also unnecessary to enter into a detailed description given by Hesiod of the armor of Hercules; of the cuirass of gold of different colors, with shoulder-pieces of iron, a richly embellished iron helmet, thigh-pieces of brass, etc.

The fragments of ancient Greek writings that have come down to us contain many descriptions of goldsmiths' work. Before we pass on, we recall the place in the Odyssey where Helen receives of Alcandra, Queen of Thebes, a gold distaff and a silver sewing basket of the most beautiful workmanship.

If the Greeks were, more than anything else, an artistic people and lovers of the beautiful, they were also poets and lovers of the marvellous. They loved to throw the halo of a supernatural origin around everything, and their imagination transformed into demi-gods the first benefactors of the human race. They deified the man who taught them the cultivation of the ground, and him who taught them how to work the metals. To this desire may be traced the existence of the Dactyles, the Cabires, the Curetes, the Corybantes, the Telchines, etc., the mysterious adoration of which appears to have had its principal seat upon Samothracea. Considered in succession as magicians, as pontiffs, and finally as demi-gods, science recognizes in them, through the misty sanctity of the fable which enshrouds them, the first adepts of the metallurgical art. According to the ancient tradition, all proceeded from Rhea, the mother of the gods, and emanated in Phrygia from the holy mount Ida.

At Samos very anciently lived a succession of celebrated artists, whose names have descended to us: Rhæcus, next Telecles, his son, as well as his grandson, Theodore, the able goldsmith who chased, it is said, the vine of gold with grapes of jewels found by Cyrus in the treasury of Sardinia.

This Theodore, who lived about seven hundred years before our era, appears to have been a favorite goldsmith of Cræsus. Herodotus attributes to him a quantity of magnificent pieces of goldsmithing which this opulent and fastidious monarch offered to the Oracle of Delphi. An enumeration of these presents, as well as those which fell into the hands of the Persian king after the defeat of Cræsus, fully justifies us to assume the King of Lydia to have been the richest man. Superstitious as well as prodigal, he knew of no better means for rendering himself acceptable to the god of Delphi than by the vastness of his sacrifices and the sumptuousness of his offerings. Not content with immolating upon its altars more than three thousand animals of all sorts, and to also burn in his honor (the most foolish waste of all) gilt and silvered beds, purple vestments, vases of precious metal, Cræsus offered to the treasury of the temple four plinths of refined gold, of the weight of seventy-seven pounds; thirteen others of pale gold (or alloyed with silver) of the weight of ninety-four pounds each; a gold lion weighing three hundred pounds; another, a silver one of exquisite work, said to have been worked by the goldsmith Theodore; four maids of silver; two basins for sacrificial water, one of gold, the other of silver; a gold statue three cubits in height; silver plates, collars, belts, etc.

It may be estimated, by this single offering alone, how great a wealth was treasured up at Delphi at the moment of its greatest prosperity. But even these treasures, devoted to religious purposes, did not escape the common lot of all and remain sacred from the cupidity of man. The Greeks themselves, in spite of all the veneration they professed for this sanctuary, freely drew upon it in their public necessities, and considered them inexhaustible treasures. The Phocians, on the occasion of a war which they had to sustain against their neighbors, smelted a lot of sacred vessels of an intrinsic value of ten thousand talents (one talent—\$2,000), and it was subsequently still further reduced by pillage and arson.

The Greeks arrived by degrees to so high an eminence in civilization that they distanced all other countries in the harmony of form and workmanship of the objects constructed by them. No one pursued the culture of the beautiful farther than they, and to them pertains the honor of having conceived the most perfect types and to have been the first to establish immutable principles of art.

It is unnecessary to dwell at great length on the quasi-mythical character of Greek workmanship, much of which has simply been preserved to us by tradition, and therefore open to reasonable doubt. Phidias was reputed to have been the most celebrated Greek gold-

smith; he constructed for the Athenians a Minerva composed of gold, silver, and ivory. THE JEWELERS' CIRCULAR contained a description of this statue a year ago, and it is therefore unnecessary to repeat it here.

The reasonable doubts which we have expressed are particularly applicable to this statue. Our readers will remember that it was of colossal proportions—about twelve yards high. Its drapery was of gold, its nude portions of ivory, etc. Without at present taking into account the great value of the ivory employed, some writers aver that about forty, and other writers even say forty-four, talents of gold (the Æginetan talent was 95 lbs. avoirdupois, the Attic talent 57) were used. This is, to use an Americanism, rather "steep."

But whether true or false, the great value of the material employed gave rise to the accusations that Phidias had "filched," and the statue stood an excellent chance of being destroyed soon after having been erected. Pericles had, with his customary sagacity, foreseen this not unlikely turn of affairs, and counseled Phidias to construct the gold drapery in such a manner that it could be taken off, which piece of advice was not heeded by the latter, however. Pericles' forethought proved to be correct; the accusation was made, and only the offer of Phidias to dismantle the gold and have it weighed calmed the suspicion of the populace.

The year 448 before our era is generally supposed to be the period when the statue of Minerva was erected.

The original went the way of all valuable objects, but a copy, constructed according to ancient descriptions, was, in 1855, exhibited at the Paris Exposition. M. Quartermère, of Quincy, draughted it, and another wealthy archæologist, the Duke of Luynes, caused it to be constructed according to the design and ancient descriptions, on a smaller scale (three yards in place of twelve). Where the ancient texts could not serve as guide, the artist scrupulously adhered to the best models of the time. The face and form of the figure was borrowed from the celebrated cameo of Aspasia, in the Vienna Museum.

After these hasty glances into the misty and mystic obscurity of antiquity, we turn our attention to

## CHAPTER II.—IMPERIAL PERIOD.

### I. THE ROMAN EMPIRE.

We have arrived at a more definite period in history: at the epoch which separates the ancient from the modern world. A new era commences. We have nothing more to do with simple tradition. Many of the works of which we are to speak are preserved and speak for themselves.

The city of the seven hills, the colony of Romulus and Remus, had not alone maintained its power, but had also become embroiled in wars with every nation of the world known at that time, and exacted from them tributes and spoils of war, by which its citizens became enriched, and little by little absorbed the art and culture of Greece.

A certain show of republican severity was maintained during the direction of the consuls, but luxury ran mad under the reign of the first emperors. Gold and silver were lavished with a senseless profusion that can barely be imagined for decorating truly fairy-like palaces erected by surfeited tyrants and vain fools. Caligula appeared to have attained the limit of the possible. Nero, after the burning of Rome, distanced him. In his famous "House of Gold," the triple colonnades of which supported a building of about one mile in length, all the dishes and utensils used, even for trivial purposes, were made of gold, those destined for his use ornamented with jewels. The beams of the ceiling were gold plated. The baths were furnished with silver tubs, into which water flowed through faucets of the same metal.

But why enumerate all this senseless show of gold and silver. It is our purpose to write a history of goldsmithing, and verily the art of the goldsmith had descended into that of the blacksmith; to construct horse mangers and hay racks of gold, or shoe horses with

gold and silver, had most certainly nothing artistic about it, and we may sum up by simply stating that the luxury of Rome gradually spread to the rest of the world. Its generals and proconsuls, gorged with wealth and habituated to all the refineries of inflated opulence, carried with them a princely train, and were accompanied even in war by all the elements of this luxury. It is reasonable to suppose that at some time, by reason of a surprise or a route, all this wealth fell into the hands of the "barbarians;" at another time they had an opportunity for burying it, to hide it from the cupidity of the enemy. This occurred seldom, perhaps, but it explains the fact that vast treasures of Roman art are sometimes found in Europe.

The most important find of the nineteenth century, perhaps, was several years ago made in the vicinity of Hildesheim, in Hanover, Germany. This treasure, the principal pieces of which have already been reproduced in great number by molding and galvanoplastic, was composed of seventy pieces, and pertained both to the useful and ornamental; vessels both decorative and for drinking; table service; kitchen utensils; furniture, such as tripods, candlesticks, etc., all of them wrought in the style of the first century of our era. The majority of the vases, flat dishes, urns, and wash basins are objects of art remarkable both for their shapes and their decorations. To this especially belongs the beautiful patera (flat dish) represented in fig. 1. The style of this piece is so pure that it



FIG. 1.

appears almost impossible that it should not have been the reproduction of a Greek model of the best epoch. The student will plainly recognize the figure of Minerva, characterized by her attributes. Several German archæologists, however, contend that it is the personification of the divinity of the protecting goddess, called "Dea Roma."

Nearly all the pieces of the Hildesheim find are stamped with their weight. This was the custom of the period. The Romans, being a practical people, estimated silverware both by its artistic and its intrinsic value. No matter what might be the merits of the piece, it was sold by weight, to establish its standard. Pliny tells us of vases which amateurs paid for with five or six thousand sestertii (1 sestertius—2½ cents) per pound.

This stamping of the weight on the pieces of the goldsmith indicated something else; silver and gold ware at that time constituted wealth—a kind of savings bank—and it was easy at any time to procure money on these "collaterals."

Several other such finds have also been made in France, one of which—the gold patera of Rennes—is preserved in the cabinet of antiquities of the French National Library. Gold objects of this nature have always been rare. Pliny himself, after mentioning a number of famous goldsmiths of antiquity, states that they are celebrated for their chasings of silver, and is astonished that they never try their art on gold.

Apart from being very valuable, on account of its age, it may be pronounced a veritable *chef d'œuvre*. We can do no better than borrow the description of an eminent archæologist, and accompany our remarks by a representation from a photograph.

"The Jatera of Rennes," M. Chabouillet says, "is a dish of solid gold, manufactured with a hammer, decorated with a central bas-



FIG. 2.

relief, and a border of Roman medallions. The central portion represents a defiance between Bacchus and Hercules, or, rather, the triumph of wine over force. A border surrounds the principal portion, and completes the design of the composition. It is, *Bacchus triumphant over Hercules*. The principal medallion contains eight personages and one animal, while the border represents twenty-nine personages and five figures of animals. A laurel wreath surrounds the border.

(To be Continued.)

### Gossip From Providence.

PROVIDENCE, July 14, 1884.

The prevailing topic of conversation for the last two weeks in jewelry circles has been the cordial welcome and splendid entertainment of the New England Manufacturing Jewelers' Association by the New York Jewelers' Club, on the 1st inst. That the guests enjoyed themselves is to use a mild term, and the kindly feelings and friendly relations inaugurated on the occasion are likely to be productive of much good will, and to make more pleasant the business relations of many who met there. Business has opened up brisk in some lines of goods, and dull in others. As a general rule it may be said that manufacturers of plated goods, always excepting plated chain, are doing quite an average trade. The large button houses find their sales pretty equal to, if not ahead, of the corresponding period last year, and some of the manufacturers of specialties, such as badges, etc., are necessarily having quite a lively time in view of the Presidential election; but those who make gold goods report trade as extremely dull, and the outlook far from flattering. This applies specially to chain makers, both gold and plated. In the latter line competition is very severe, and a few days ago a member of a prominent house told me that he had positively declined to sell his goods at figures which were quoted, and preferred resting on his oars for the time being. The plated sets, etc., for this season's trade are many of them noticeable for their artistic design and superior finish, and quite justify the remark of a veteran maker: "It will soon be impossible to distinguish the difference between the gold and plated goods by a mere superficial examination." The indications are that credits will be handled more carefully this season than formerly. That many of the wholesale dealers are too much extended to render them a fair business risk is a fact well known to the majority of the trade, and this, coupled with extreme slowness in collections, certainly renders great caution necessary.

The monthly meeting of the New England Manufacturing Jewelers' Association was held in their rooms on the 5th inst. After the usual routine business had been gone through, the President, A. S. Potter, addressed the meeting in terms highly eulogistic of the manner in which the Association had been entertained by the New York Jewelers' Club, and, after similar remarks from various members, a resolution passing a hearty vote of thanks to the latter club was put to the meeting and carried amid hearty acclamation. It was announced by Mr. Dodge, of the Executive Committee, that the esteemed Secretary, Mr. John McCloy, was expected back from his bridal tour about the 14th inst. It was moved by Mr. Dodge, and seconded by Mr. O. C. Devereux, that a reception should be tendered him and his bride, at the rooms of the Association, on the evening of Saturday, July 19. The motion was carried unanimously, and a committee, consisting of the President, Secretary and Treasurer, was appointed to make the necessary arrangements.

By the way, I should like some psychological student to inform me if mendacity is contagious. The reason I ask is this: At the commencement of the present season a firm here hired a young man, whom I knew well, as a salesman. He was a very nice boy, parted his hair in the middle, shaved every morning, eschewed strong drinks and all the other temptations that so easily beset us. He was a prominent member of a Sunday school, and his veracity was unimpeachable. Well, a few short weeks ago he went to your city, hung out at the Hotel Astor, where the drummers love to congregate, and I presume got indoctrinated into their ways. Last week I met him, and the first thing I heard was: "You said I could not sell G. & M., didn't you?" "Yes," I replied, somewhat taken aback, "did you sell them?" "Well, I should smile," said he; "guess I did \$1270 net." "You don't say so." "Yes, upon my word it's true," said he. I believed the young man on account of his past record, and mentally predicted a great future for him, more especially as G. & M. were particularly hard men to sell to. Well, sir, that same afternoon I met that young man's employer and remarked, "I'm glad to learn you sold G. & M. a nice bill." "A nice bill!" was the reply, "Well, I'm glad your so easily satisfied; but if you call seventeen dollars and thirty cents a nice bill I don't." Alas, for that young man. *Sic transit gloria mundi.*

ASMODEUS.

### A German Branch of Industry Becoming Obsolete.

A GERMAN BRANCH of industry is, it appears, becoming obsolete by reason of the whims of fashion and unfavorable proportions: we refer to the agate cutting of Oberstein and Idar, in the Oldenburg principality of Birkenfeld. This and kindred branches of art industry flourished there some twenty-five years ago, and had gained a world's reputation. About 150 business men and 2,100 artisans were engaged in these arts, while numerous goldsmiths made the settings for rings, breastpins, etc., for the artistically cut and polished stones. As late as 1880 it was hoped that the time would return when the manufacture of ring stones, seal stones, and breastpin stones were a lucrative branch of industry, and the artistic productions of stone cutters were in demand and paid for at high prices. These hopes were fallacious, however, and in 1881 complaints were heard on all sides that the good days of agate cutting were past. This state of affairs is chiefly due to (1) change of fashion, (2) general state of impecuniosity in Europe, (3) overstocked American market, which latter is the chief provocative of European activity or dullness. European papers, day after day, burthen their columns with abuse of the "Yankees," whenever they manage to spell the word correctly; but as soon as these "Yankees" manufacture the article themselves or cease buying it, there is a general state of starvation in that particular branch in Europe. For affirmation we quote the Swiss watch and silk industry, Lyons silk industry, Elbeuf cloth industry, *ed id omne genus.*

## The Jewelers' Security Alliance.

President, DAVID C. DODD, JR.

Vice-President, AUGUSTUS K. SLOAN.....Of Carter, Sloan & Co.  
Treasurer, W. C. KIMBALL.....Of H. F. Barrows & Co.  
Secretary, C. C. Champenois.....Of Champenois & Co.

### EXECUTIVE COMMITTEE.

C. G. ALFORD, *Chairman*.....Of C. G. Alford & Co.  
C. B. BISHOP.....Of Carrow, Bishop & Co.  
HENRY HAYES.....Of Wheeler, Parsons & Hayes.  
J. B. BOWDEN.....Of J. B. Bowden & Co.  
DAVID UNTERMAYER.....Of Keller & Untermeyer.  
E. F. DORRANCE.....Of Dorrance & Brother.

P. O. Box 3277.

Room 2, 170 Broadway, New York.

HON. ALGERNON S. SULLIVAN, *Counsel.*

The following were admitted members of the Jewelers' Security Alliance at the meeting of the Executive Committee on July 8th, 1884:

A. Bahn, Austin, Tex.; H. F. Hahn & Co., Chicago, Ills.; J. C. Herkner, Grand Rapids, Mich.; C. F. Happel & Co., Chicago, Ills.; Chas. F. Irons, Providence, R. I.; Leyson & Turck, Butte, Mont.; C. R. Nichols, Fulton, N. Y.; J. P. Stevens & Co., Atlanta, Ga.

## The Jewelers' League.

President, GILBERT T. WOLOM.....Of Woglom & Miller.  
First Vice-President, WM. C. KIMBALL.....Of H. F. Barrows & Co.  
Second Vice-President, AUG. KURTZBORN.....Of L. Bauman Jewelry Co. St. Louis, Mo.  
Third Vice-President, JAMES P. SNOW.....Of G. & S. Owen & Co.  
Fourth Vice-President, HENRY HAYES.....Of Wheeler, Parsons & Hayes.  
Secretary and Treasurer, WILLIAM L. SEXTON.....Of Sexton & Cole.

### EXECUTIVE COMMITTEE.

ROBERT A. JOHNSON, *Chairman*.....Of Colby & Johnson.  
SAMUEL W. SAXTON.....Of Saxton, Smith & Co.  
CLEMENT B. BISHOP.....Of Carrow, Bishop & Co.  
JOSEPH B. BOWDEN.....Of J. B. Bowden & Co.  
GEORGE R. HOWE.....Of Carter, Sloan & Co.  
CHARLES G. LEWIS.....Of Randel, Baremore & Billings.

THE JEWELERS' CIRCULAR is the *exclusive* official paper of the Jewelers' League, and has been selected for the publication of all matters of interest pertaining thereto. Letters or inquiries pertinent to its business or purposes, and which might interest the trade or inquirers, will herein be answered. Address *Jewelers' League, Box 3,444, P. O., New York*, or the office of THE CIRCULAR.

THE LEAGUE has never held out inducements to join it, by claiming that a certain amount of benefit could be had by the payment of a certain sum per year; such statements might be made, based upon a former low death rate, which mislead to the presumption that the future will be as low as the past death rate. It has been invariably stated in its authorized utterances that the cost depends upon the number of deaths of its members, and that the rate must necessarily increase until the average mortuary rate is reached, when it will cost between \$50 and \$75 per annum; if the deaths should exceed  $1\frac{1}{4}$  per centum of the membership, the excess will be paid out of the contingent fund now accumulating for such contingency. Notwithstanding the absence of such specious inducements, as are offered by most of the societies, the freedom with which the privileges of membership in the League have been embraced by the members of the jewelry and kindred trades is very gratifying, and is evidence that the past, present and future of the League are generally well known, appreciated and anticipated. In a body of over 3,000 men, however, there are always a few of such as join without consideration of the responsibilities which must accompany, as the outcome of, the benefits in such organizations, and such men are apt to as thoughtlessly question the propriety of the wisest measures.

One member writes that from the language of the constitution but one assessment can be ordered at a time; that an assessment implies a limit of two dollars. This claim may be demonstrated as lacking breadth by reference to Art. II, Sec. 2, of the constitution:—"Any man of good moral character and good general health, not over forty-

five nor under twenty-one years of age, who is now, or has been for one year immediately prior to the date of his application, engaged in the jewelry or kindred trades, is eligible to membership in this League." If his premises are correct, just as surely the membership is limited to a single man, to "any man," a position as untenable as the claim that the scope of the language should be limited to one assessment, because the language is all in the singular number. On his membership certificate he will read that he is "subject to all the requirements and entitled to all the benefits." If entitled to the benefits he is subject to all the requirements. Now, as was tersely stated on a recent assessment notice, "the League has no discretion as to when a member or members shall die," and cannot devise means to control the fact nor the time of deaths; it must submit to the inevitable and conform to the provisions of Sec. 1, Art. VI., viz.: "Upon satisfactory proof of the death of any member, the League must pay a certain sum as therein provided;" if more than one death be proven at a time it must provide for plural deaths, and the only way to provide for them is to assess the members for them; the League is bound thus to do, and as the League is composed of nothing but its members, its members are bound thus to provide. The League is as a purse, no more can be taken out of it than is put into it; it does not and has not promised anything else. There are those that do, and men join them, such men as Jeremy Taylor had in mind when he wrote "men are apt to prefer a prosperous error to an afflicted truth." The League, however, is not afflicted except in the estimation of thoughtless members who cannot realize that it is worth what it costs to carry \$5,000 insurance.

The New York State Legislature, during its last session, enacted three laws which are of vital interest to members of our benevolent societies. One law exempts the reserve funds of such societies from taxation, and permits them, if they so wish, to deposit any amount of security with the Insurance Department; another compels all accident companies to pay the full amount of weekly indemnity, whether the member was in receipt of wages greater or less than the weekly indemnity insured for; another law exempts from attachment the amount paid to widows by such societies; this latter is in addition to a section of Chapter 175 of the Laws of 1883, which exempts from attachment the amount *to be* paid to a beneficiary, in other words the money or other benefit, charity, relief or aid cannot be attached nor diverted by any legal process from the purpose for which it is intended, either while in the keeping of the society nor after it reaches the beneficiary. New York State joins hands with our societies in protecting the unprotected, and 'tis well it is so, for, to use another Hibernianism, "What's all the wurruld to a man when his wife's a widdy?"

A special meeting of the Executive Committee was held in the office, No. 170 Broadway, on June 23d, at which were present President Woglom, Vice-President Kimball, Secretary Sexton, Messrs. Johnson, Lewis and Bowden. Proofs of the deaths of James A. Clancy of Selma, Ala., and Henry H. Eaton of Nashua, N. H., were presented, and, being found in proper form, an assessment of four dollars was ordered, notice of which was sent to the members on June 28th.

The regular meeting day of the Committee occurring on the National holiday, it was voted to adjourn to July 11th, and on that day a meeting was held, at which Vice-President Kimball, Secretary Sexton, and Messrs. Johnson, Bowden and Lewis attended. Five changes of beneficiary were granted, eleven delinquents were reinstated, one application was rejected, ten were tabled for investigation, and the following 23 applicants were admitted:

D. Rosenheim, W. S. Richardson, F. H. Richardson, E. E. Egler, N. Y. City; C. B. Helfenstein, Brooklyn, N. Y.; A. Roseman, Elmira, N. Y.; J. N. Price, C. J. King, Philadelphia, Pa.; J. A. Mitsch, Allegheny, Pa.; J. F. Sumner, Boston, Mass.; T. Latkowski, No. Attleboro, Mass.; H. H. Thompson, Brattleboro, Vt.; J. Koebler, Cleveland, O.; J. J. B. Barnes, Louisville, Ky.; E. Aschaffenburg, New Orleans, La.; L. L. Fischer, Chattanooga, Tenn.; E. L. Crane,

Humboldt, Neb.; C. J. Noack, Sacramento, Cal.; G. P. Rose, Jr., Dubuque, Iowa; J. H. Copeland, D. Copeland, Marshall, Texas; W. Timms, Cleburne, Texas; J. A. Martin, Paris, Texas.

Since writing the statement in the first paragraph with reference to the future mortality rate in the League, we have received some interesting statistics published in a recent number of the *Guardian*, of Boston. It appears that, taking all the life insurance companies that have existed in this country, and are still existing, and for each year of their existence, from the 1st to the 41st, aggregating their death losses, also the mean amount at risk, and deducing therefrom the death cost for each succeeding year, the first year shows a cost per \$1,000 of \$3.66, increasing with more or less regularity until it reaches \$15.28 per \$1,000, in the 41st year. Dividing the business of the whole number into periods of ten years each, we find that in the first decade the death cost for each \$1,000 of insurance was \$8.16; in the second, \$10.11; in the third, \$12.05; and in the fourth, \$14.01. Now apply this ratio directly to the amount of benefit paid by the League, \$5,000, and, from the fullest and most authentic statistics obtainable with reference to life insurance in this country, we may premise, without fear of contradiction, that for the first, second, third and fourth decades of the League's existence the death cost will be respectively, \$40.80, \$50.55, \$60.25 and \$70.05 per annum, an average of \$54.33. We are therefore justified in repeating our assertion in *THE JEWELERS' CIRCULAR* of November, 1883, quoted approvingly by the League in its assessment notice number 29, that "every year during which the members are assessed less than \$50 each for the current year they should feel happy in the possession of a 'bargain' by reason of their membership in the Jewelers' League."

---

### Proceedings of the Horological Club.

---

#### A DISTINGUISHED BODY OF WATCH AND CLOCK MAKERS.

*One hundred and twenty-second discussion.—Communicated by the Secretary.*

[NOTICE.—Correspondents should write all letters intended for the Club separate from any other business matters, and headed "Secretary of the Horological Club." Direct the envelope to D. H. Hopkinson, Esq. Write only on one side of the paper, state the points briefly, mail as early as possible, as it must be received here not later than the eighth day of the month, in order to be discussed and reported in the *CIRCULAR* for the next month.

---

#### BOOKS ON GILDING AND ENGRAVING.

##### *Secretary of Horological Club:*

I would like to make a few inquiries in regard to gilding, etc. Is there any book that I can get that will give me the desired information, or is it published in any number of *THE JEWELERS' CIRCULAR*? Also a book on general engraving, monograms, etc.? Will you answer by letter or through *THE CIRCULAR*?  
A. W. V.

Mr. Clerkenwell said that there were a number of books on gold and silver plating, but they were of little use to the watch repairer. One of the best was "Watt's Electro Metallurgy." Another was "Gee's Gold Worker." A good deal has been published in *THE CIRCULAR* from one to three years back, and the back numbers of *THE CIRCULAR* would probably give as much reliable information as could be got anywhere.

As for engraving, there is no work published on the subject. A valuable series of articles was published in *THE CIRCULAR* by "Expert" about three years ago. There are two or three books giving collections of monograms, etc. They are frequently advertised in *THE CIRCULAR* with price, etc. Any of above can be had at *THE CIRCULAR* office, or from Henry Cary Baird, Philadelphia.

#### BROKEN MAINSPRINGS.

##### *Secretary of Horological Club:*

I replaced a broken mainspring for one of my customers last week. The old one was broken into thirty-two pieces. Can the Club tell me why so many pieces? They were broken in straight lines from

the arbor to two or three outside coils. My customer says it was not broken while winding. The spring was put in the watch (which is an Ellery) by a traveling tinker, who used oil by the quart. I enclose the pieces for the Club to examine.  
W. E. W.

Mr. McFuzee said that such cases were not at all rare. Sometimes the number of pieces is even greater than that. Why they break in that way is not clear. It is supposed that for some reason the different coils are all under strain at the same place—as by a very long hook in the barrel arbor causing all the coils to bend over it when wound up tight—and that when one breaks the shock at once causes all to break in the same line. If they all fly outward alike, the break will open, and the ends of the pieces will all be in a line from the center. The width of the opening will depend on how much larger a circle the pieces now occupy than they did when they broke—the difference will be the amount that the ends spread apart.

#### ABOUT HOROLOGICAL SCHOOLS AGAIN.

##### *Secretary of Horological Club:*

Will any member of Club or reader of *CIRCULAR* give their opinion and advice concerning the advisability and benefits to a young man of attending a horological school, and the address or any information concerning any such school that they may have knowledge of, and oblige one who is interested?  
S. S.

Mr. Uhrmacher said that there were several good horological schools abroad. Mr. Morritz Grossmann, of Glashutte, Saxony, published a statement of the terms and requirements of the school under his charge in *THE CIRCULAR* some months ago. His school is the one best known in this country. Mr. S. can reach others by writing to "The Director of the Horological School," at Geneva, Locle, and Chaux-de-Fonds. As to the advisability, etc., he could only say that if one means to learn the trade at all it is advisable to learn it well. He did not consider it a very promising trade for a young man to learn, but if his tastes inclined strongly to it, and he was resolved to be as good as the best, he should avail himself of every opportunity to improve and learn, and a few years at one of these schools is probably one of the quickest and best ways to become practically skillful.

#### PROTECTING WATCHES FROM MAGNETISM.

Mr. Electrode said the members would recollect that some time ago he had commented upon a so-called "Magnetic Arrester," and had declared that there was no such thing, that no substance was known which could stop magnetism, etc. The newspaper clipping which furnished the matter for those remarks was incomplete, and gave no description of the "arrester." He had since received a circular issued by Giles, Bro. & Co., of Chicago, with a description of the device manufactured and sold by them for protecting watches from magnetism, and had carefully read the same, but there was not a word about stopping magnetism. Hence he concluded that that expression was simply the idea of our friend Pitman, who sent us the clipping for notice. The device does not arrest or stop magnetism. It is a modification of the soft iron cases or shields which were sold at the Vienna Electrical Exposition for protecting watches from magnetism. Those shields enclosed the watches, and when the magnetic lines of force met the shields they were continued *through the iron* to the other side of the shields, instead of through the movement. Pure soft iron offers the least resistance to the magnetic influence of any substance known, and almost infinitely less than air. Hence, when the lines of force meet the iron on one side of the shield, instead of leaving the iron and continuing through more or less air to the other side of the shield (or going through the movement) they *follow the iron* to the other side of the shield, and then continue on till they reach the other pole of the magnet, which is the source of these magnetic lines of force. That is to say, the iron offers the lines of force an easier path *around* the movement than they would find in going *through* the movement, and in that way it protects the movement from the magnetic influence. The shields do not stop magnetism, nor *can* they do that. They simply induce the magnetism to occupy the iron of the shield instead of extending directly through



the movement. He hoped this explanation would be so full that even those who are not electricians could understand *how* the watch is protected from magnetism.

He was sorry to see that the circular still contained the nonsense about the compensation balance forming "a sort of mild battery," the hair spring "attracting" and conducting the current, "magnetic currents," etc., etc. There is no such thing as "magnetic currents." The disturbing force is magnetism, which is supposed to polarize the space between the poles of the magnet, and which is represented by "lines of force" in that space. When these lines of force are once formed, so long as the space remains polarized there is no change of condition or position, and, therefore, *no* "current." The lines of force simply represent the *direction* of the magnetic influence, or attraction and repulsion. He thought it would be well for the gentlemen to employ Prof. Elisha Gray or some other competent electrician to re-write their circular, and weed out these absurd and meaningless expressions, and get it technically correct. Those who wished to know more about the true nature of the injurious effects produced by electricity and magnetism upon watches would find his former remarks upon this subject in our Proceedings for June, and he would not repeat them here.

Having thus disposed of the *theory* of the subject, he would now return to the device employed by Messrs. Giles, Bro. & Co. to accomplish their purpose. The circular says:

"This Anti-Magnetic Shield is warranted to protect a watch from any magnetic influence it would be subjected to in actual use, and is made on purely scientific principles, and only accomplished after many tedious and expensive experiments. It is composed of pure gold and copper, and decarbonized steel of the finest quality, so arranged as to obtain the results required. The decarbonized steel is the greatest absorbent of the magnetic current known to science. Copper is one of the best conductors, and gold offers scarcely any resistance and is used as a diffusing agent, hence the result of absorbing, conducting and diffusing the magnetic influence before it reaches the watch movement."

Now, as a matter of fact, copper and gold are good conductors of electricity, but, as regards protecting the watch from magnetism, they have nothing whatever to do with it. Whatever virtue the device has resides exclusively in the "decarbonized steel," and the copper and gold might as well be in the gentlemen's pockets for all the good they do around the watch. Hence the talk about their "absorbing, conducting and diffusing the magnetic influence" is blank nonsense. If they would say that they are used to cover the steel, protect it from rusting, and make it look like a gold case—that would be the truth, as well as good common sense, and a good idea. It would, in fact, be something akin to an idea which he (Mr. E.) had invented a number of years ago for protecting watches from magnetism, viz.: A case which was in appearance precisely like any watch case, but which really consisted of pure iron, covered over with gold, silver or even nickel to give it a good appearance—that is, it was a filled case, in which the filling consisted of pure iron. He had tried, a year or two ago, to get some of our "enterprising" case makers of New York and elsewhere to take hold of them, but without success. He hoped by the time Giles, Bro. & Co. had made a few hundred thousand dollars by being wide awake and supplying a great public want that these "enterprising" case manufacturing companies would begin to get their eyes opened far enough to see a good thing when it was urged upon them. It is a good thing to be cautious, but it may not be a good thing to be blind. However, tastes differ sometimes.

He hoped Messrs. Giles, Bro. & Co. would perceive that his strictures were directed only at the errors and unscientific statements of their circular. As for the device itself, it is a good one, which will protect the watch if properly applied. The whole movement is surrounded with "decarbonized steel,"—the "shield" covering the sides and back, and a thin plate of the same material being inserted under the dial to protect the front. The different parts of the device are very ingeniously arranged together. He was glad to see that *some-*

*body* had enterprise enough to take the field and supply an article which is urgently needed, but he also regretted that they should block their own efforts by circulating among the trade publications containing statements and expressions which were positively exasperating to one having any knowledge of electricity and magnetism. If they would get some electrical expert to weed out these excrescences from their circular, and make it technically true and correct, he would "shake hands across the bloody chasm" and wish them all possible success in introducing their Anti-Magnetic Shield.

Owing to the excessive heat the Club now adjourned till next month.

## Sight.

### WHAT THE OPTICIAN SHOULD KNOW ABOUT OPTICS.

Based upon an extensive hospital experience in Austria, Germany, England and New York. By C. A. BUCKLIN, M. D., New York. Author of Detection and Correction of Visual Imperfections, Cause and Cure of Cross Eyes, Effects of Color on Distance, and Monograph on Astigmatism.

*Continued from page 116.*

#### A QUESTION IN OPTICS.

*To the Editor of the Jewelers' Circular:*

Will your optical editor please tell me through THE CIRCULAR as to what is the trouble with my eyes. For reading and working at the bench I require No. 30 convex glasses; for looking about the room and at objects five to eight yards, see clearly without any glasses; while to look at objects twenty to forty yards off I require No. 36 concave, or near-sight lenses.

Have sold glasses for twenty-five years, but the saying, "Physician heal thyself," will not answer in my case; and if not too much trouble would be pleased to have the opinion of your optician. Aged 47; have worked at watch work nearly twenty-eight years; never required any spectacles until a year ago. Yours respectfully,  
W. P. L.

You are  $\frac{3}{8}$  near-sighted. This amount of near-sight will only make vision at five yards appear indistinct when the pupils are large. The above being true, you are using at your working distance, at the age of 47, a magnifying power equal to convex No. 16 $\frac{1}{2}$ ,  $\frac{1}{8}$  of which is represented by the glass you wear, and  $\frac{1}{8}$  of which is represented by your "myopia."

The ball of your eye is too long to receive distinct images from very distant objects, and your power of accommodating has been weakened by age, perhaps assisted somewhat by the too early use of convex lenses.

Your experience, however, will not be found to be an exception to that of other persons of your age who are slightly near-sighted.

The above is what I believe to be the condition.

Cataract in its earliest stages occasionally gives rise to trouble closely resembling that which you describe. This is due to the slight myopia produced by the swelling of the lens.

I also refer you to page 39, "Detection and Correction of Visual Imperfections," for a description of false near-sightedness, which, in exceptional cases, will explain the trouble you complain of.

#### CURABLE AND INCURABLE BLINDNESS.

I am energetically collecting information for statistics showing how many curable blind persons there are who are completely ignorant of the fact that their sight is not hopelessly lost. I also desire to know as many as possible who are incurably blind, that I may have statistics showing how great a per cent. of these persons have unnecessarily become blind. If any of the readers of THE CIRCULAR will answer the inquiries below regarding any blind person they may know, I will be very grateful for the information, and will inform them, if desired, whether the sight can be restored or not.

Please state name, age, address.

At how many feet light from a candle can be distinguished in a dark room with each eye.

At how many inches can each eye distinguish fingers with the back to the light of the window.

Is the "cornea" clear? Is milky spot seen deep in pupil?

Have eyes ever been injured?

Were they ever red or painful?

### Jewelers' Day.

THE SOCIAL element in the jewelry trade finds various modes of expression, but no method adopted is conducive to keener enjoyment than that which has for several years been followed by the New England Manufacturing Jewelers' Club and the Jewelers' Club of New York. Both these clubs had their origin in the great national game of base ball. Providence formed a ball club composed of young men in the trade, and New York had a similar association. One challenged the other to play a match game, which challenge being accepted, the other members of the trade naturally championed the play of their local clubs. For several years these games were played, first in one city and then the other, and as local pride became interested, the clubs naturally grew in membership and importance. It was soon ascertained that these organizations were worthier of something better than a game of ball, and that by enlarging their sphere of usefulness they could be made a medium for receiving and extending social courtesies, for obtaining relaxation and enjoyment, and for affording opportunities for men engaged in the same line of business to become better acquainted with each other, thus doing away with some petty jealousies and cultivating the better side of men's natures. So the Providence Club was expanded to the New England Club, and the New York organization so enlarged its by-laws as to admit to membership any reputable person connected with the jewelry trade, regardless of location. The interchange of hospitalities between the two cities of New York and Providence has been continued, but more rational amusement has superseded the game of base ball.

This year the New York Club entertained the New England Club on July 1st. As that was the day of the publication of THE CIRCULAR last month, we could do no more than note the fact that the arrangements for the festivities were completed, and of such a nature as to insure a most enjoyable re-union. The event fully justified our prediction. As early as six o'clock the members of the reception committee of the New York Club began to assemble at the Astor House, but not being used to such early rising, and the atmosphere being a little hazy, they were very much discouraged, thinking it was going to be a stormy day. That they were not familiar with early morning weather in New York was soon evident, for the sun came out at the usual hour bright and clear, and in a short time made everything hot and sultry. By half-past six a liberal number of the club had assembled, and, at the word of command, formed in column, headed by the Seventh Regiment Band, and marched to the foot of Warren street to receive their guests. Here, on the steamboat *Massachusetts*, they found the members of the New England Club, to the number of 150, accompanied by an excellent band. After the customary salutations, line was formed and the two clubs returned to the Astor House, where breakfast had been prepared for the party. Ample justice was done to this matutinal repast, after which an hour was devoted to informal conversation, and then the order was again given to "fall in." The line being formed once more, each member of the two clubs was presented with a neat cane, the gift of the New York Club. The entire party, hosts and guests numbered something over 400 persons, and they made a very handsome appearance as they marched down Broadway. The members of the New England Club wore straw hats with a black band, and old gold gloves, while the New York Club wore straw hats with blue bands, and drab gloves. With their neat canes and smiling countenances, they were as jolly a looking procession as ever charged down Broadway.

Arriving at Pier 1, the party embarked on the iron steamboat *Cygnus*, which had been chartered to take them on an excursion down the bay. Such baggage, band equipments, etc., as the guests had brought with them, had been transferred to the steamer by the United States Express Company, that sent a wagon for them, the four horses and wagon being decorated with flags and bunting. The trip down the bay was one of thorough enjoyment; the boat is large and comfortable, and every convenience for the entertainment of the party had been made by a thoughtful and efficient committee. While the weather was oppressively hot in the city, the excursionists had the benefit of a refreshing sea breeze, and were as cool and self-possessed as so many commercial travelers. Various points of interest in the harbor were visited, the two bands discoursed delightful music, and quartettes and solos by the members of the clubs contributed to the enjoyment of the occasion. After three hours of sailing the boat touched at the Iron Pier, Coney Island, where the excursionists landed and proceeded to the Brighton Hotel. Here "mine host" Lansing, knowing the nature of his guests, and being familiar with the appetites they carry about with them, had provided a bountiful dinner, even at the risk of bankrupting the culinary department of his establishment. Notwithstanding the facts that yearning stomachs urged them to charge upon the dining-room, they were persuaded to restrain their ardor for a few moments while Hatton, the photographer of New York, took a flying shot at them with his camera. The result was a very good picture of the two clubs and bands, looking very hungry. It needed no second summons to secure their attendance in the east dining-room, that had been reserved for their use. Here a delicious banquet was served in the elegant style that has made Lansing noted as a caterer. The menu was as follows:

#### MENU

##### CLAMS

Little Neck on shell

##### POTAGE

Consommé of chicken à la royal

##### POISSON

Baked bluefish with wine sauce

Sliced cucumbers

Potatoes hollandaise

##### KELEVE

Saddle of Canada mutton à la Soubise

String beans

Potatoes au gratin

##### ENTREE

Tenderloin of beef piqué à la Duxelles

Green peas

##### ROTI

Spring chicken farci

Salade de saison

##### DESSERT

Napolitaine ice cream

Assorted cakes

Fruit

Cheese

Café noir

July 1st, 1884

HOTEL BRIGHTON.

With the introduction of coffee and cigars began the "feast of reason and flow of soul." It was well known that quite a number of the party were loaded with speeches, and only waited an opportunity to fire them off at their innocent and unoffending companions. The opportunity had now come. President Ellison started the oratorical pyrotechnics by briefly and fittingly extending a cordial welcome to the visiting club. Mr. A. S. Potter, on behalf of the New England Club, replied in a complimentary manner, expressing the thanks of the club for the hospitalities they enjoyed so much. Then the mourning festivities began. T. L. Parker had a few words of condolence to offer the mourners, and was followed by R. A. Johnson in a few pathetic remarks that brought tears to the eyes of even the dumb waiter. Then Jacob Marx took a turn at the windmill, and even the ice pitchers wept at his eloquence. Then the New England Club took an innings, B. L. Hall at the bat, and he did some terrible execution—when he got through there wasn't a dry man in the room. The guests being proposed as a formal toast, Mr. D. J. Ayres responded in an eloquent manner. Several others made remarks, but they were generally addressed to the waiters in an undertone. The oratorical effervescence having been thus worked

off, the party broke up into groups and "took in Coney Island." They were welcomed everywhere, and were permitted to bathe in the ocean, to write their names on the sand, to hunt for clam shells on the beach, to run foot races on the Concourse, to wink at the pretty fortune teller, to ride in the merry go-rounds, and, in fact, to sport around like other reputable citizens or frolicsome children.

The excursionists re-embarked for New York about four o'clock, arriving in time to connect with the *Massachusetts* for Providence, by which many of the New England Club returned to their homes. As the steamer drew out of her dock she was saluted with rousing cheers from those on shore, which were heartily responded to by those on board.

The committee of the New York Club are entitled to great credit for the satisfactory manner in which Jewelers' Day was observed and enjoyed. They worked hard and without intermission, their labors not ending until the close of the trip. There were present as invited guests representatives of the trade from Chicago, Cincinnati, Philadelphia, St. Louis, Cleveland, Boston, etc. Representatives of the press were present from Providence, Attleboro, Pittsburgh, Chicago, St. Louis and New York.

The principal duties of the day devolved upon the Reception Committee, which was composed of the following named gentlemen: J. B. Bowden, Chairman; J. W. J. Pierson, J. T. Scott, Jr., H. Untermeyer, D. Keller, C. J. Fox, Kossuth Marx, L. Neresheimer, J. W. Steele, C. D. Marsh, C. C. Champenois, J. D. Yerrington, W. C. Kimball, Louis Kahn. The marshal was G. N. Fenn, and his aids were C. A. Boynton, E. Untermeyer, G. C. Booth, M. J. Lichtenburg.

The officers of the New York Club are: B. W. Ellison, President; S. P. Howard, 1st Vice-President; J. S. Cooley, 2d Vice-President; J. W. Senior, Secretary; J. G. Fuller, Treasurer. *Executive Committee*: T. L. Parker, Chairman; R. A. Johnson, Vice-Chairman; A. Pinover, F. H. Bliss, J. Marx, Wm. Bardel.

The officers of the New England Club are: A. S. Potter, President; W. H. Luther, R. S. Hamilton, E. A. Robinson, Vice-Presidents; John A. McCloy, Secretary; H. F. Carpenter, Treasurer. *Executive Committee*: O. T. Devereux, B. W. Dodge, F. T. Pierce.

The day was one long to be remembered, and tended to more closely cement the fraternal feelings existing between the two organizations. "May they live long and prosper."

### George Graham and his Watches.

UNDER the above title, we find a very characteristic anecdote of George Graham, the celebrated inventor of the anchor movement, in a German contemporary; whether true or not, at least it speaks of a man held in reverence by all watchmakers, and we therefore transfer it to the pages of THE CIRCULAR for what it is worth.

As is well known, Graham was a quaker. He one day sold a watch to a stranger, and guaranteed its correct rate. The purchaser said that he was on the eve of embarking for East India and desired to know how long he could depend on the good rate of the watch.

"My friend," said Graham, "I have constructed and regulated the watch myself; thee can wear it, whenever thee desires, and if thee comes after seven years and says that thy watch differed by five minutes, I will return thy money."

After the lapse of seven years, the purchaser really returned to the watchmaker, and said, with assumed sobriety, "Mr. Graham, I return you your watch."

"Ah, I remember," responded Graham; "let me see it; what objection has thee against it?"

"What objections I have against it? In the seven years that I owned it, it deviated more than five minutes."

"Well, I will return thy money—"

"How do you mean?"

"I will keep what I promised."

"Really?"

"I never speak otherwise."

"But I will not sell my watch," answered the owner, "and if you were to pay me ten times its value."

"And I," said Graham, "will not break my promise under any consideration. I promised to take back the watch for certain reasons. In consequence of this promise thee brings it back, and no power on earth can force me to break the contract."

And Graham kept his word, and the watch remained in his hands.

### A Rare Case for Spectacles.

THE LADY referred to in the following article having applied to Wm. J. Suttie, Optician, for an adjustment of spectacles to suit her defective vision, he found the case presented so many peculiar features that he referred her to Dr. Francis Valk, who makes the following report, which will be found interesting to all readers who have anything to do with fitting glasses for their customers:

Mrs. S., age 23, was sent to my office by Mr. Suttie, on November 9th, 1883, with the following history: She first went to school at the age of seven years, and *at that time*, when studying, would always place her books as far away from the eyes as possible, or stand away from the teacher, while the other scholars would be at the teacher's knee. This continued, and as she advanced in age, she would sew and read at arms length, so that her work would be constantly slipping off of her lap; she would try to bring the work or her book nearer, but vision would blur, and at once she was compelled to remove it.

She has never suffered with any of the acute diseases of childhood, as scarlatina or diphtheria, and only a slight attack of measles; while since then has always enjoyed excellent health.

The other members of her family have enjoyed good eyesight, except one sister, who has been troubled with a medium degree of hyperopic astigmatism, while her mother did not become presbyopic until she was fifty years of age. Mrs. S. can read for several hours steadily without any material fatigue, provided she holds the book at a distance of about two feet; and always prefers to read in a medium light, as a bright light is too dazzling. She has sometimes felt slight attacks of pain, referred to the ball of the eye, when reading for several hours, but did not consider that she had any particular trouble until she came to me with a slight attack of catarrhal conjunctivitis that yielded readily to proper treatment.

On ophthalmoscopic examination the media is clear, and the fundus appears perfectly normal, with a slight amount of hypermetropia, about 1 D. On testing her distant vision it was found to be:

$$V. R. E. = \frac{1}{6}.$$

$$V. L. E. = \frac{1}{6},$$

with a manifest hypermetropia in each eye of  $+\frac{1}{6}$ .

Her near point with No. 1 *Jaeger* was found at 20 inches, and the far point at 30 inches, in each eye; with a slight blurring of the vision in the right eye when reading very fine type.

She has homonymous diplopia at a distance of 16 feet, with a prism of  $12^\circ$  base upwards, placed before either eye, that is corrected with a prism of  $3^\circ$  base outwards; while the internal rectus can only overcome a prism of  $8^\circ$ , and the strength of the external rectus is represented by a prism of only  $5^\circ$ .

Her positive part of accommodation shows only  $\frac{1}{20}$ , and the negative part  $\frac{1}{6}$ , with the visual axis fixed at her near point of 20 inches; and her range or power of accommodation is only about  $\frac{1}{15}$ , with a region of 10 inches, which exists only at arms length, or at 20 to 30 inches.

She was placed under a four-grain solution of sulphate of atropia for four days, instilled three times a day, when the distant vision in each eye had fallen to  $\frac{1}{6}$ , and with a convex glass of 36 inches

focal distance was brought up to normal, or  $\frac{1}{6}$ , showing a *total hypermetropia* of  $+\frac{1}{3}$  in each eye.

In looking over this history and seeking for an explanation of the results contained therein, and endeavoring to arrive at a definite diagnosis, we are compelled to do so by exclusion, or by negative results, as, while the present symptoms would indicate the existence of partial paralysis of the ciliary muscle, or muscle of accommodation, we can find no cause in her past history for any such conclusion, as this condition has existed evidently since early childhood, when she was not afflicted with any disease to cause a condition of paralysis, and we must throw out that diagnosis.

I am inclined to think, that as we study the various phenomena presented by this case, that there is no pathological condition whatever existing; that when the visual axis is fixed on infinity her slight degree of hypermetropia is overcome by the action of the ciliary muscle, and we have vision  $=\frac{1}{6}$ , or normal; but when the vision is brought to a nearer point and divergent rays enter the eyes, the normal action of the ciliary muscle fails to respond, the vision becomes blurred, and No. 1 Jaeger test type can only be seen at arms length, or 20 to 30 inches; conclusively showing that there must be an almost *total absence* of any accommodative power. This is particularly shown in the right eye, from the fact that she frequently complains of a blurring of the vision of that eye, with dilatation of the pupil.

If we compare the results obtained in this case with those of the normal eyes, both as regards the *extrinsic* and *intrinsic* muscles of the eye, they will be found far below the standard, as the power of the external and internal recti, as shown by the test with prisms, is only about one-third of the strength of the normal extrinsic muscles. She can only fuse the images with a prism of  $8^\circ$  with the base outwards, and one of  $5^\circ$  with the base inwards, while the normal standard exists at about  $20^\circ$  for the internal rectus, and about  $12^\circ$  for the external rectus.

I should consider that this weak condition of the muscles of abduction and adduction of the eyes probably due to the fact that her near point is so far removed from the eyes that the muscles have had no stimulus to develop their contractile tissue to the normal strength and action.

As regards the intrinsic muscle, or the muscle of accommodation, all the tests to which it was subjected it failed to respond. Compare the positive and negative part of accommodation, or the relative range, and we find it only as 1 to 1; while in the normal eyes it should be as 2 to 3, and in my own eyes, with the visual axis fixed at the same angle, it exists as almost 1 to 2.

Also examine the binocular range of accommodation, and that falls to about  $\frac{1}{5}$ , very far below the normal range or power of  $\frac{1}{4}$ , showing that the accommodative power is almost nothing—a fact also well shown in the region of accommodation, existing at 20 to 30 inches, a region too far removed to be of any practical service whatever.

As it is a self-evident fact that in this case there is an almost entire absence of any accommodative power, it would be well to consider what are the essential elements concerned in that act?

The normal or emmetropic eye, when all its refractive elements are at rest, will so bend parallel rays of light, or rays from infinity, that they will exactly focus on the retina at the macula lutea, and there produce an exact inverted image of the object to which the visual axes are directed; but as this object is brought nearer to the eyes, the rays of light become more and more divergent and will focus behind the retina, producing on that sensitive layer of nerve cells, circles of diffusion, or blurred vision, provided the refractive media remains at rest and the refractive angle remains the same; but the inherent power of the eyes will abhor any blurred vision, just as "nature abhors a vacuum," so as the object is brought closer to the eyes the act of accommodation takes place, or, I may say, the power of the eye to adjust itself to vision at different distances, and so bend these divergent rays of light to exactly focus on the retina. To accomplish this act, the intrinsic muscle of the eye, or muscle of

accommodation, contracts, whereby the zone of zinn is relaxed, and the anterior capsule of the lens is pushed forward towards the anterior chamber by the elasticity of the crystalline lens; this increases its refractive power, so that it can exactly focus or bend any divergent rays of light that enter the eye from different distances.

This process has been proved and demonstrated beyond a doubt, and by this means we are enabled to see the smallest type when brought very close to the eye. But in this case we have a condition, first, of hypermetropia, or a congenital shortening of the eyeball, so that the ciliary muscle must contract, to focus parallel rays of light, and make distant vision perfect; but there her power practically stops, and we are compelled to conclude that the fault must lie in the diminished action of the ciliary muscle, or muscle of accommodation; and I should think there must be either a congenital deficiency of the fibers of that muscle, or a condition of muscular atrophy occurring in early childhood; hence the only diagnosis possible: an almost total deficiency of the accommodative power of the eyes, probably congenital.

The treatment or relief of this case requires very few words at my hands, as the conditions existing cannot be removed, but can be corrected by placing before the eyes a convex lens that will so bend divergent rays of light, when coming from a distance of about ten inches from the eyes, that they will exactly focus on the retina; or, in other words, apply power in front of the eyes to correct the deficiency of the accommodative muscle, and so render vision clear and distinct.

---

### Uncertainties of Diamond Mining.

WE SEE by our Amsterdam exchange, *De Diamant*, that there are blanks even in diamond digging. In its *Coursblad in the Kaapsche Diamantmijners Maatschappigen* it gives a list of twelve companies at the Kimberley Mines, only four of which paid dividends last year, the highest 15, the lowest 3. o. 4—but whether pounds, francs, marks or Japanese taels the paper does not state; presumably, pounds, being in the British possessions. De Beer's mine, with nine companies, has four dividend paying companies, the lowest with o. 2. o., the highest with o. 10. o.; Du Toit's Pan mine, twelve companies, two of which with "divis," one o. 3. o., the other o. 15. o.; Bultfontein mine, six companies, two pay dividends, viz., o. 4. o. and o. 10. o.; finally, the Jagersfontein mine, five companies, all of which are blanks.

Considering the vagueness of not alone this, but also various other European statistical exhibits, we are compelled to state as a well known fact that although America may learn lessons in the industrial branches from Europe, still, when the question concerns business, an American primary school boy can lay the European statistician in the shade. There is always a vagueness, a lack of precision about European statistics that leaves room for the reader's imagination. The very first act of the said schoolboy would have been to introduce somewhere in his tabular statement \$ cts., or £ s. d., as the case may be. It is one of the rarities of literature to see a really well prepared tabular statement coming from the continent.

---

### A New Automatic Striking Work.

[By ANDREAS GULBRANDSEN, of Hønefoss, Norway.]

THE present invention can be employed for all kinds of clocks, and is a great simplification of the striking works hitherto in vogue, as it is either continuously or at short intervals wound by one of the wheels of the minute or running works, so that the entire wheel work for the propulsion of the striking work is dispensed with.

In order to reduce to a minimum the loss of power experienced by the motion work for this purpose, I have entirely altered the con-

trivance actuating the hammer, and arranged it into a kind of escapement in such a way that it required less power, and beside this it is more easily constructed. For the same purpose the winding contrivance for the striking work has been arranged thus that the labor necessary for this is equally as possible divided over the twelve hours. A new way of unlocking is also introduced with the winding arrangement.

The new striking work is exhibited in three modifications in the accompanying cut. In all cases, the striking work is essentially composed of: the winding parts, the escapement regulating the action of the hammer, and the striking.

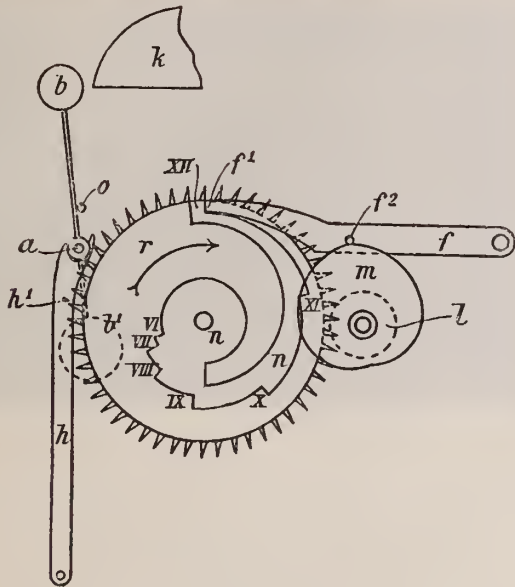

Fig. 1 a

Fig. 1a shows the most essential parts of the first modification of the striking parts; Fig. 1b, the escapement in an enlarged scale. The winding of the striking parts, effected by the pinion *l*, fig. 1c, sitting upon the center arbor, the leaves of which seize into those of the scape wheel *r*, and turn it to the left, contrary to the operation of a balance spring or weight connected with *r*, but not shown in the cut. Of the 14 leaves of the pinion, 2 have been filed away so that only 12 leaves remain, and the scape wheel, at each revolution of the pinion *l*, is turned by 13 teeth to the left. But as soon as at the end of each hour the notch of the pinion *l* is placed opposite to the escape wheel; this is removed out of depthing with the pinion *l* so that it can return freely to the right in the direction of the arrow,

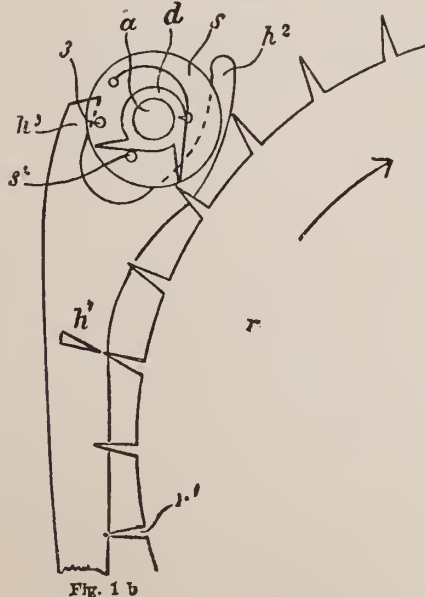

Fig. 1 b

fig. 1a, impelled by aforesaid spring or weight. During the latter motion now takes place the striking *a*; the escapement next to be

described, regulates not alone the revolution of the scape wheel, but also sets the hammer into activity, influenced by the latter. The hammer *b*, sitting upon the axis *a*, is placed out of balance by a



Fig. 1 c

counter weight *b*<sup>1</sup>, and by a weak spring, not represented in the figure, it is drawn to the right against the pin *o*. Upon the hammer axis *a*, sits loosely a pinion *d*, fig. 1b, with two oblique teeth, which is pressed by means of a small spring around to the left against the pin 3 of the disc *s* fastened upon the axis *a*. The axis *a* is also embraced by the two prongs *h*<sup>2</sup>, *h*<sup>3</sup>, of the lever *h*, provided with locking jewel *h*<sup>1</sup> and revolvable around its lower end, which on account of its breaking functions shall be called "brake;" the gong is finally marked with *k*. In the accompanying position of the striking parts the hammer has just now struck a blow and the small pin *s*<sup>2</sup>, at the further side of the disc *s*, has just now encountered the prong *h*<sup>3</sup>, and thereby moved the brake *h* to the left, so that the locking jewel *h*<sup>1</sup> has become unlocked and the scape wheel is free. The scape wheel turning to the right now seizes the first leaf of the pinion *d*, and the hammer axis and hammer swing thereby to the left. When the scape wheel seizes the second leaf of the pinion *d* the pin *s*<sup>2</sup> strikes against the prong *h*<sup>2</sup> of the brake, and thereby the locking jewels of the same, *h*<sup>1</sup>, moves in so far that the tooth *r*<sup>1</sup> of the scape wheel braces itself against the tooth *h*<sup>1</sup>. The scape wheel is hereby retained exactly at the spot where it is possible that the two leaves of the pinion *d* can pass by unhindered between two teeth of the scape wheel. On account of the impulse received from the scape wheel, the hammer is meanwhile at first turned sufficient to the left until the spring on its axis offers too much resistance, or until the tooth *s*<sup>2</sup> encounters the ends of the prong *h*<sup>3</sup>, whereupon it will, exactly like a balance, swing again to the right, again disengage the escapement by means of the pin *s*<sup>2</sup>, and finally strike a blow upon the gong *k*. The position of the parts is now again the same as at the beginning, and the escapement can again perform a new play and a fresh blow, which is repeated until the scape wheel is detained by the regulating mechanism.

In winding, the teeth of the scape wheel *r* must be able to pass by the pinion *d*, and for this reason the pinion *d* sits loose upon the hammer axis. The pinion *d* has, therefore, about the same action as a ratchet tooth, and may also be arranged in this manner, as will be specified further below. As will be seen with this motion work, one blow is struck upon the gong for each 2 teeth of the scape wheel. The contrivance serving for the regulating of the striking is arranged as follows: The sketch shows the position of the striking work when the clock has just struck 12. The drop *f* revolving around the right end rests with the tooth or pin *f*<sup>2</sup> upon the highest point of the heart-shaped regulating disc *m* sitting upon the hour axis, and strikes with its left end *f*<sup>1</sup> against step XII of the snail *n* which sits upon the scape wheel *r*; this disc is provided with 6 other steps marked with the figures XI. to VI., which are arranged in such a combination with the heart disc that by a one-twelfth revolution of the heart disc (corresponding to 1 hour), the end *f*<sup>1</sup> of the drop is placed exactly one step lower (or by the second revolution of the heart disc, higher), upon the disc *n*. Now, during the first hour the scape wheel is by the pinion *l* upon the center axis turned by 13 teeth to the left, while at the same time the tooth *f*<sup>2</sup> of the drop sinks so much that *f*<sup>1</sup> comes at even height with the step XI. Since now the distance of the steps XII. and XI. exactly correspond to 11 teeth of the scape wheel, it is evident that the scape wheel—in its unlocking and succeeding revolution to the right—can only revolve by 2 teeth, and that the clock, therefore, strikes 1. The distances of the following steps of the disc *n* now correspond either with 9, 7, 5, 3 and 1 teeth of the scape wheel *r*, so that the clock strikes in the subsequent unlockings of the striking

parts, 2, 3, 4, 5 and 6. The pin or tooth  $f^2$  of the drop now lies upon the lowest point of the heart disc, and  $f^1$  against step VI. of the disc  $n$ . By 7 o'clock the scape wheel has again turned by 13 teeth to the left; the end  $f^1$  of the drop, however, is raised again by one step by the heart disc, and pin  $f^2$  wherefore the scape wheel can now turn by 14 teeth to the right and the clock strikes 7. It will now easily be seen in what manner the clock strikes 8, 9, 10 to 12 in the course of the escaping hours as the succeeding distances of steps permit that the escape wheel can always turn by 2 more teeth than by the preceding full hour.

From the preceding will be seen that the scape wheel from 12 o'clock to 6 is turned  $6 \times 13 = 78$  teeth to the left, while the striking work in the same time only uses  $2 + 4 + 6 + 8 + 10 + 12 = 42$  teeth, that therefore the scape wheel was  $78 - 42 = 36$  teeth turned too much to the left. But these teeth are consumed again between the hours of 6 and 12, because for these hour strokes  $14 + 16 + 18 + 20 + 22 + 24 = 114$  teeth are necessary, while the scape wheel was wound only by 78, therefore,  $114 - 78 = 36$  too little.

For the striking, therefore, it is actually the same how many teeth the scape wheel has, and only from considerations of construction with regard to the arrangement of the steps of the disc  $n$ , is it desirable that the wheel have at least 36, that is,  $11 + 9 + 7 + 5 + 3 + 1$  teeth. For the sake of preventing, however, that the spring of the scape wheel by the forcible turning of the hands be wound too strong it is advisable to limit the winding, and this is easiest obtained by filing 2 teeth of the scape wheel somewhat thinner so that they are not seized by the pinion  $l$ , while they still are capable to set the hammer into activity. The scape wheel must then receive at least 51 teeth; because by 6 o'clock it has been turned by 36 teeth to the left, and at 7 o'clock by another 13, together 49, to which are to be added 2 teeth for filing.

In the preceding winding contrivance the labor expended has in a certain manner been equally distributed, because the scape wheel spring will in each hour be turned by 13 teeth, while the tension of this spring, however, increases a little between the hours of 12 and 6, but diminishes between 6 and 12.

(To be Continued.)

## Problems in the Detached Lever Escapement.

BY DETENT.

THE FRICTION which holds a canon pinion to the center arbor of a watch is not necessarily great, but it must be constant, so that at any position in which the hands are left there will be sufficient adhesion to carry them steadily forward. When the watch was new the friction extended the whole length of the canon pinion; and when it wore loose it is hardly possible to create any friction at one mere point which is going to be satisfactory, except we make the friction an elastic one, as is adopted by some of our American watch factories with their stem winders. In consideration of the fact that all of our full-plate American watches have canon pinions after the manner of the English, and the fault of loose pinions are so frequent, I feel justified in giving a method for remedying this defect perfectly. It takes a little time and some special tools, but there are few customers but are willing to pay for having the job well done, especially if it is explained to them that any method of makeshift only gives a temporary relief, and will ultimately injure seriously their watch. The plan I propose is one used by one of our largest watch factories, but the manner of accomplishing the job in the repair shop, I think, is original. But as it does the work effectually, it is of the least possible consequence where the idea originated. The plan is to cut away a portion of the canon pinion so that an elastic tongue or spring is formed, which presses with a constant force against the center arbor, sufficient to insure the regular going of the hands. To make the matter plain, at fig. 1 is shown a canon

pinion enlarged, the portion between  $g$  and  $f$  representing the cylindrical part on which the socket of the hour wheel goes;  $h$  the square to which the minute hand is fitted;  $j$  the pinion. The first thing to be done is to soften the canon pinion so it will be readily cut with a milling tool. There are several ways of doing this; first, by covering the pinion with castile soap and heating up to a red heat, letting it cool slowly with the soap protection; second, a small, thin wrought iron tube shaped as shown in longitudinal section at fig. 4. To make such a tube, take a piece of round iron known as brazier's rod, and drill a hole in one end large enough to receive any canon pinion; then tap a plug of iron into one end, as shown at  $l$ . To

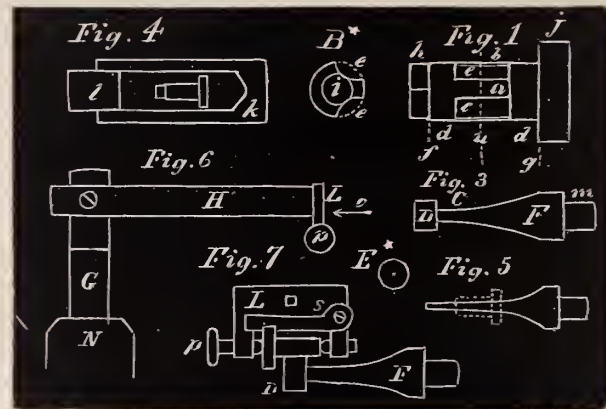

soften a pinion in this, put the pinion in as shown, and fill up the space with brass filings; screw in the plug  $l$ , and heat the whole up to a pale cherry red, covering the box or tube with a small piece of charcoal to aid in cooling off slow. After the tube is cold, take out the plug  $l$ , and the pinion will be found quite soft. After the pinion is put into shape (as we will shortly proceed to describe) it can again be packed into the tube, heated up to a red heat, and plunged into cold water (if in summer, ice water); when, on opening the box, the pinion will be found hard. It should now be annealed by heating with oil or bees-wax until either catches fire. The philosophy of this is: the tube  $k$  protects the pinion from all air, except what is mingled with the brass filings in the tube; but as brass oxidizes at a lower temperature than steel, the brass filings take up all the oxygen inside the tube, and the steel consequently prevented from even coloring to any extent. And in the hardening the chill of the cold water is imparted so quickly to the pinion as to harden it effectually. This system admits of many other applications for watchmakers' use. After the pinion is soft, we will proceed to get it in shape. The first special tool is a taper chuck to fit any live spindle lathe, or, in case you use bow lathe, a taper arbor to fit the hollow of the canon pinion. At fig. 5 is shown such a chuck, and, at the dotted outline the canon pinion. The use of such a chuck is to enable us to reduce the size of the canon pinion between the dotted lines  $d d$ , as shown at  $b$ , fig. 1. The next tool is a mill, shaped as shown at fig. 3, where  $m$  represents the end which screws into the spindle of your lathe, and  $D$  the mill. At  $E^*$  is shown an end view of the mill. By the word "mill" I mean, in this case, a steel cylinder about  $\frac{1}{10}$  of an inch long and  $\frac{1}{8}$  in diameter, cut into fine teeth in the direction of its axis. The neck of  $F$ , shown at  $C$ , is about  $\frac{1}{2}$  of an inch in diameter. The mill  $D$  would be best cut with a wheel-cutting engine, but it can be cut with a graver; the graver lines should be deep and well incised. The tool for holding the canon pinion is easily made, and is shown as seen in the direction of the spindle of the lathe at fig. 6. The piece  $G$  is a bit of wire just as large as will go into the hole where the lathe rest goes. One half of  $G$  is cut away to permit the bar  $H$  to be screwed to it by the screw  $n$ . The bar  $E$  is made of heavy (No. 10) brass, and about  $1\frac{1}{2}$  inches long; and has a cross-piece  $L$  secured to it for holding the pinion; this head or cross-piece is shown at fig. 7, as it seen in the direction of the arrow  $o$ , fig. 6. This head is shaped as shown at fig. 7, and would be best if made of steel and hardened. The canon pinion is held between two steel centers shown at  $p r$ .

The center at  $p$  is provided with screw and milled head, so that  $L$  will hold pinions at any length. The head  $L$  is provided with a latch  $s$ , which goes into the leaves of the pinion to hold it in any position. In fig. 1, at  $B^*$ , is shown a transverse section of the canon pinion on the dotted line  $u$ ; and at  $e e$  are shown the cuts or incisions made by the mill  $D$ ; these cuts extend into the hollow part of the pinion at  $i$ . Now, these two incisions would leave the bar  $a$ , fig. 1, extending from  $d$  to  $d$ ; and if this bar  $a$  is cut off at where the letter  $a$  is shown, the bar  $a$  can be bent inward and serve (after hardening and tempering) as an elastic spring to hold the canon pinion in place, and also producing a smooth, even tension for the canon pinion, which will never wear loose. We will suppose we have an English or American canon pinion which is too loose on the center arbor; we put it into our annealing box and soften it; we next slip it on the taper arbor shown at fig. 5, and reduce the size of the canon pinion as shown between the dotted lines  $d d$ , fig. 1. Next insert the pinion in between the centers  $p r$ , fig. 7; slip the latch  $s$  into one of the leaves of the pinion to prevent the pinion turning by the action of the mill  $D$ . Now insert the piece  $G$  into the tool post, and adjust the parts so the pinion will be presented to the mill or cutter  $D$ , so as to cut a recess, as shown at  $e$ , in the cross-section at  $B^*$ . After one recess is cut, lift the latch  $s$  and revolve the canon pinion about four of its leaves, securing it in position again with the latch  $s$ ; and cut another recess  $e$ . The tongs  $a$ , fig. 1, is cut loose at one end, as has been described, with a screw head file. After hardening and tempering, this friction will be found to be all one can desire.

THE TIME of the invention of wheel clocks moved by weights is uncertain. Some enthusiasts are found to assert that 220 before Christ such a clock was made—in the time of Archimedes—but there is no evidence to support such a belief. The first unquestionable fact that can be stated upon the subject, is that Pope Sylvester II. did construct a wheel clock with weights, at Magdeburg, in 996, and it is just possible that this was only a revival of an early invention, and that Boethius was the originator of the mechanical wheel clock in A. D. 510. One thing, however, is certain, namely, that clocks were in ordinary use in the monasteries of Europe in the eleventh century, and no doubt the monks, who had plenty of leisure and ample means for the cultivation of experimental science, perfected them, and in a large measure contributed to the perfection of their machinery as we know it. In 1370 a clock was made in France which was considered a marvel of accurate time keeping, and which may have had a pendulum, but we cannot find positive evidence of the discovery of the use of the pendulum until the days of Galileo, although ancient astronomers are said to have used them in computing the duration of the eclipses. From the date of Galileo's discovery to recent times constant improvements have been made in the science of horology until it has reached what we may call perfection.

The great contest of watches, or, more properly, of clocks, between Huygens and Dr. Hooke, in the seventeenth century, is a matter of history, as are also the discoveries to which they gave rise in regard to the elliptical shape of the earth; but, dismissing such deeply scientific problems, we will content ourselves with a glance at the introduction of the first watch, or portable clock. Edward VI. appears to have been the first Englishman to wear a watch, and this consisted of "onne larum gilt, with two plummets of lead;" that is to say, it was driven by weights. This is supposed to have been received by the king as a present from Nuremberg, and was playfully called a Nuremberg animated egg. The word "watch" was derived from an Anglo-Saxon word meaning to wake. The first portable time-piece of which we have any record was that of the Chinese pocket dial mounted upon the head of a cane or carried by a chain round

the neck. An Italian sonnet written by Gaspar Viconti, in 1490, makes mention of watches, and Shakespeare refers to one in "Twelfth Night," when he makes Malvolio say: "I frown a while, and perchance wind up my watch." Queen Elizabeth had a watch in shape exactly like a duck, with chased feathers, the lower part of which opened, and the face or dial was of silver, ornamented with a gilt design. The outer case was of brass, and that in its turn was covered with black leather ornamented with silver studs. Mary Queen of Scots gave a curious token of her affection to her faithful maid of honor, Mary Seaton, in the shape of a watch in the form of a skull, the dial occupying the place of the palate and the works that of the brains. The hours were marked in Roman letters. A bell in the hollow of the skull received the works and a hammer struck the hours. Striking watches were uncommon, and in the time of Louis XI. a stolen watch was discovered in possession of the thief by its striking. Guy Fawkes and his associates had a watch when they intended to blow up the Houses of Parliament, "to try conclusions for the long and short burning of the fusee." All these early watches had but one hand, and required winding up twice a day, until, in 1550, springs were substituted for weights.

### Lathes and Lathe Work.

BY THE MODEL WATCHMAKER.

WE WILL now consider the fitting up of our lathe heads. It is as well to call them heads, although they are both head and tail stocks, as the reader will remember. I described the manner in which the ways were to be fitted up in the June number of this journal, and since then I have written to several parties about the probable cost of fitting (planing and parallel grinding) such a set of ways, but up to the present writing have not received satisfactory figures, but will give them to my readers as soon as ascertained. In fig. 1, at  $A, B, C$ , are shown one of the heads in three positions;  $A$  being a side view as seen looking at right angles to the axis of the lathe.  $B$  is a view seen in the direction of arrow  $d$ .  $C$  is a view seen in the direction of the arrow  $f$ . The parts marked  $c c$ , diagram  $A$ , should be about one inch thick, and cast of the best soft gray iron. They will need no planing, but can be fitted up entirely by filing and scraping. The parts shown at  $g g$  are raised about one-eighth of an inch so as to facilitate fitting up, as these projections go against the upper face of the ways, and if they are an inch wide on their face they will permit the heads to be moved sufficiently to turn as taper as one will need often. We will first fit up the parts of our heads, which goes on the face of the ways. To do this we should provide a face plate for testing our work on. About the most convenient plate for such work is a piece of extra heavy plate glass,

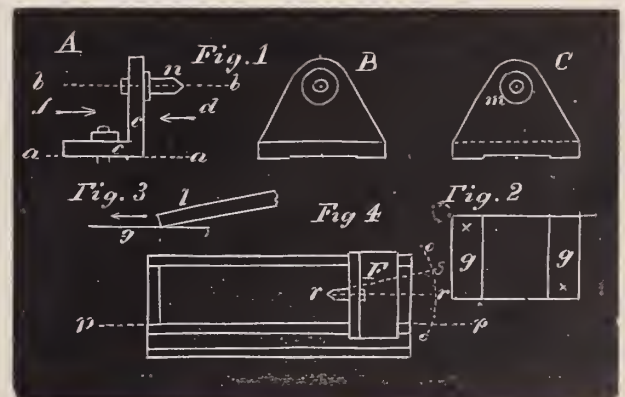

about 12 inches square. A very good test of the truth of the face of such a piece of glass, is to place it some distance from an object presenting a straight line, like the edge of a door casing; then removing the eye to a similar distance and see if the line or casing looks straight in the reflection; if it does, the surface is true; if, on the other hand, it distorts the object, it is untrue, and consequently unfit

for a test plate. Usually plate glass is quite true enough to answer. At fig. 2 is shown a bottom view of the head block, as if seen in direction of the arrow *i*, fig. 1. The test or face plate of glass just described should be ground or roughened by rubbing with emery and water, and a bit of the same plate glass three or four inches square. After the castings are made they should be *pickled* by rubbing or painting over them dilute solution of sulphuric acid and water (about  $\frac{1}{4}$  acid). The application can be made with a swab formed of a bit of cotton rag tied on a stick for a handle. It will require from 24 to 36 hours to loosen and remove the scale on the castings. The dilute acid should be applied every three or four hours until the scale sloughs; when the castings should be well washed with plenty of water and dried quickly to prevent rust. We commence the fitting by setting one of the head blocks on the face plate and ascertaining the highest parts which we are to start on to filing. It is to be supposed we have a good-sized vise and large course files (by a coarse file I mean, say a 12-inch bastard). At first it is easy enough to find the parts on which to begin filing, but after a little we shall have to have something to smear on our face plate so we can tell exactly where to file and scrape. We will now suppose we are nearly flat with the parts shown at *g g*, fig. 2. We next mix some red lead with olive or sperm oil and smear over the surface of our glass test plate. There does not need to be enough red lead and oil on the test plate to appear like a coat of paint, but only enough so you can see the color distinctly. We next apply the head block to the glass and gently rub it back and forth. We now turn it up, as shown in fig. 2, and find the parts marked with the crosses slightly stained; these indicate the marked parts as highest. These parts should be filed with judgment and tested repeatedly until the entire focus of *g g* are flat. After the parts are as true and flat as they can be filed, resort should be had to the machinist's scraper, as shown in fig. 3. Such a scraper is merely an old flat file ground smooth on each side, and the end ground exactly square, as shown at *l*. The right angle corners will cut as true and smooth as can be desired, testing with the face plate and scraping. There is no planer in existence which will plane as true as one can fit up with a file and scraper. The motion of scraping is indicated by the arrow in fig. 3; it is simply pushing the scraper forward, holding it at such an angle as will cause it to *bite*. The method of using is very simple, and a little practice after reading the above will enable any person to use one to advantage. The manner of sharpening is only to grind off the end again square until the angles are restored. At *m*, diagram *B*, is shown a circular ring which projects slightly beyond the general face; this is ultimately to be filed and scraped flat and at right angles to the line *a a*, diagram *A*. But, first, we will get our heads fitted. The second head (or tail stock) we will next fit up in the same way as the one just described. We have now our two heads fitted so they will rest on our ways without rocking. This feature is of greater importance than, at first thought, would seem possible; but a little thought will convince one that a head out of true on the lower surface, if clasped to the ways with considerable force, will have an appreciable effect on the truth of these ways. This will not be so apparent in the mere act of turning with the ordinary tool as it will in grinding or turning with a milling tool. I would beg to say to those persons who would be satisfied with a moderate degree of accuracy, that good gray cast iron ways, simply planed with a good metal planer, can be used to make tools of a great accuracy; as, for instance, a micrometric gauge, which will accurately measure  $\frac{1}{1000}$  of an inch. It must be borne in mind that the skillful man will produce work of superior excellence with tools of *known* defects, than an inferior workman can with tools of almost absolute perfection. And it is the writer's aim to instill into the minds of his readers principles rather than specific instructions. We have now our two head blocks, which sit steady on our ways in any position in which they may be placed. Our next effort should be to provide centers perfectly parallel to those ways; such a center is shown at *n*, diagram *A*; the axis of such center

should exactly coincide with the dotted line *b b*, which should be parallel to the plane of the surface of the ways. The surface of *m* should be at right angles to the line *b b*. These centers should also have their axis parallel to the guiding edges of the ways; as, for instance, the dotted line *r r*, which represents the axis of one of the centers, and the dotted line *p p*, the guiding edge of one of the ways. It will be seen that, as the lower part of heads are fitted with quite broad flat bearings on the ways, the heads can be shifted so as to change the direction of the axis, as, for instance, to the dotted line *s*. It is usual in slide rest lathes to let the head block (carrying the spindle) stand with its axis parallel to the ways, when we wish to turn taper and shift the tail block over; but in the lathe we have in consideration (and in others too, if it could be conveniently done) it will be our endeavor to keep the centers in line.

---

### Nickel in the United States.

ALTHOUGH nickel was discovered in Europe only in 1751 by Cronstadt, it has in China been in common use for over 2,000 years, as proven by old Indian and Persian coins. The majority of nickel articles, however, do not consist of pure metal but are alloys. The alloy ordinarily employed for coins contains about 23 per cent. nickel and 77 nickel copper. The production of pure metallic nickel and the art of working it are inventions of recent years.

Nickel ores are far more plentiful in the United States than is commonly believed. They are principally found mixed with chromic ores on the Pacific coast, more especially in Oregon. In the eastern states they are chiefly encountered in Litchfield County, Connecticut, the highlands of the Hudson of New York and New Jersey, and more especially in the vicinity of Lancaster Gap, in Pennsylvania. The latter region furnishes the greater portion of the nickel used in the United States. The ore contains from  $1\frac{1}{2}$  to 2 per cent. of pure metal. To concentrate it it is smelted together at the mine, whereby a concentrated ore, containing 10 per cent. and more of pure nickel is obtained. To the most important of these plants may be counted that of Mr. Joseph Wharton, who has in the last decade introduced various improvements in the manufacture and working of the metal, and whose very large establishments are located at Camden, N. J., in the vicinity of Philadelphia. From the time that electric nickel plating has been so universally employed, a large part of the ores are converted here into nickel salts and anodes. At an early day already Mr. Wharton endeavored to solve the question whether nickel might not also be produced in a pure metallic state, endowed with the requisite properties of being hammered and welded like iron. The preferable properties of nickel, its great firmness and capacity of resisting chemical influences were known a long time ago, but a method was still wanting to use them to advantage.

In order to investigate this matter fully, Wharton, by chemically reducing the oxide, produced a pure spongy nickel which he welded together at a red heat with a steam hammer. The product obtained in this manner was a malleable nickel. In 1873 he sent a few articles of nickel, produced in this manner, to the Vienna Exposition, and in 1876, to the Centennial Exposition, where, however, they remained almost unnoticed by the great public. The report of the Philadelphia Commission said: "A handsome collection of nickel ores from Lancaster Co., Pa., together with concentrated nickel ore, metallic nickel in grains and cubes, pieces of cast and wrought nickel, nickel magnets and nickel magnetic needles, cast cobalt, electroplatings with nickel and cobalt, salts and oxides of these two metals, all of which represents a noteworthy advance in the metallurgical treatment of these metals." Nor was due attention paid to these articles at the Paris Exposition of 1878, because they were placed in the shade by other nickel articles manufactured from better alloys, especially those of Christoffe, of St. Denis, near Paris, and of



Vivians, of Swansea, Sweden. Nevertheless, the gold medal was awarded to Mr. Wharton for his articles, being the only ones manufactured from the pure metal, which was at that time a great rarity.

The great advances made in the working of pure nickel are doubtlessly due to the method for making it malleable, and invented by Dr. Fleitmann, of Iserlohn, Westphalia. The pure metal, obtained by the ordinary process, is frequently full of cavities when cast, is hard and troublesome to work, which deteriorating properties are caused by a gas, very probably carbonic oxide gas, inclosed or dissolved in the metal. Dr. Fleitmann expels this gas by adding a little metallic magnesium to the fusing metal, which decomposes the carbonic oxide gas by the separation of graphite and thereby oxidizes to magnesia. This process takes place remarkably quick and almost a small explosion occurs. The magnesium must, therefore, only be added in small pieces while constantly stirring. One ounce of magnesium suffices for 60 pounds of nickel. It is undoubtedly true that malleable nickel has been obtained by another method before Dr. Fleitmann, still, this magnesium process is the most preferable.

The nickel obtained by this method is extremely tough, malleable and may be rolled into sheets and drawn into wires. Cast plates also may be rolled from it. The anodes for electro-plating are produced in this manner, and in the bath show a greater homogeneity than those that are simply cast. Sheet nickel of the thickness of a sheet of paper is at present rolled at Camden. The use of pure nickel, however, is not to be recommended in many cases, plating upon sheet iron being better. Fleitmann manufactures such plated sheet iron by welding thin sheet nickel upon the two sides of the previously cleansed and smoothed sheet iron, in which process 2 parts nickel are generally counted to 8 parts iron. The welding together, after heating, of the iron and nickel sheets is performed between rollers and a strong pressure. In order to protect the metal against oxidation in the heating and rolling, the plates are enveloped in a separate protection of sheet iron, which, of course, must not be welded on at the same time. The nickel welded upon the iron adheres excellently well, and since both metals possess nearly the same mechanical properties they may afterward be rolled out into still thinner sheets. These sheets are by Fleitmann also recommended for steam boilers. Nickel plated iron and steel wire is manufactured in the same manner. Both nickel plated sheet iron and wire will at a not distant day become an important article of use; the sheet iron will among other purposes be also much employed for cooking utensils; they will always have handsome surfaces, are harder, more durable and lighter than sheet tin, nor, when empty, are they given to melt similar to the latter.—[*Techniker*.

---

### The Cut in Watch Movements.

WE ANNOUNCED in THE CIRCULAR last month that a cut in the prices of watch movements was imminent, and that in anticipation thereof the Waltham Watch Company had issued a circular to the trade announcing that when the cut should be made they would protect all holders of their movements, whether jobbers or retailers, by allowing them a rebate on the goods they had on hand equal to the amount of the cut. The Elgin Company on the first of the month made an average reduction of ten per cent. on the price of their movements, and on the 15th the Waltham Company followed with even a more liberal reduction. The rebate promised by the latter company to retail dealers was something hitherto unknown, except in one instance of the Waltham Company rebating a special movement in 1876, and there were those in the trade who pretended to think that the Waltham Company would not redeem its promise in this respect. Their circulars of July 15th, however, which will be found on their advertising page in this issue, not only reaffirms that promise but directs dealers how to proceed to

recover the rebate allowed. The plan adopted is as simple as could be devised to secure safety to all parties concerned, and involves only a small amount of trouble to the dealer. The reduction announced and rebate allowed is as follows:

|                     |   |         |
|---------------------|---|---------|
| American Watch Co., | 16 size, nickel, 1st quality, S. W. . . . . | \$50.00 |
| Amn. Watch Co.,     | 16 size, nickel, 2d quality, S. W. . . . .  | 20.00   |
| Hillside,           | 14 size, gilt, 3 pairs, S. W. . . . .       | 3.25    |
| Hillside,           | 14 size, gilt, plain, S. W. . . . .         | 3.25    |
| Ellery,             | 18 size, gilt, 2 pairs, S. W. . . . .       | .75     |
| Ellery,             | 18 size, gilt, 2 pairs, Key. . . . .        | .20     |
| Sterling,           | 18 size, gilt, plain, S. W. . . . .         | 1.00    |
| Broadway,           | 18 size, gilt, plain, Key. . . . .          | 1.00    |

Nothing that has occurred in many years has given rise to so much comment in the trade as this action of the Waltham Company. Heretofore when a manufacturer has seen fit to reduce his prices, he has allowed a rebate to those jobbers who had a supply of his goods on hand, but the retailers who were stocked up with them had to stand the full effect of the cut himself or lose his customers. This worked a great hardship to the retail dealers, especially as to watch movements, for to make sure of these they are obliged to file their orders in advance and thus generally accumulate a liberal supply. If, after being stocked up, the retail dealer finds the prices knocked from under him, he has had no recourse but to pocket the loss. But in this instance the Waltham Company steps in and says: "Show me what your loss is in consequence of our reducing prices and we will make it good to you;" a precedent is thus established for securing equity and justice to the retail dealers, that they will, no doubt, insist upon being observed by all manufacturers in the future. It was a bold innovation for the Waltham Company to make, but once having resolved to meet the competition forced upon them, the Company determined to protect every one, jobber or retailer, who handles their goods. Whatever loss ensues in consequence of their reduction is thus assumed exclusively by this Company. Heretofore the dealer who carried a well selected stock of movements has been placed at a disadvantage whenever a reduction in price has been made, while the one who carried no stock could meet the demand by buying at the cut prices and so undersell the more careful dealer who kept his stock full. Thus the manufacturers were virtually cutting the throats of their best customers and giving the preference to those who do business on the hand-to-mouth principle. But under the new policy inaugurated by the Waltham Watch Company, the provident retailer, who carries a stock equal to the anticipated demand, is guaranteed against a cut-throat competition originated and encouraged by manufacturers. The retail dealers receive the same degree of protection that jobbers have heretofore enjoyed exclusively when prices have been reduced.

As we have stated in previous issues, we deprecate exceedingly a competition that necessitates any change in prices that have been fixed so long that they have become standard, familiar alike to all dealers and to the public. Abnormally low prices for goods of any description indicate an unhealthy condition of the market from some cause. There must be some reason not made public that induces the first break, and suspicion and curiosity are naturally aroused; the trade becomes unsettled and excited not knowing to what such cutting under may lead. If the breaking away from standard and remunerative prices is regarded as being in the interests of the trade it is a great mistake. Dealers seek to obtain a profit on their sales proportioned to the cost of the goods; it is almost like selling on commission; the lower the price at which goods are sold the less the amount of profit to the seller. A cut in prices like that just taken place in movements is soon known to the public and every purchaser demands the full benefit of the reduction; the dealer, in consequence, makes no profit by it; on the contrary, he is put to much trouble and annoyance for which he receives no compensation. Fair and honorable competition is good for trade, and it is also an assurance to the public that there can be no extortion; but that competition that upsets and unsettles standard prices, demoralizing trade

and introducing chaos where order reigned, works nothing but injury to all concerned. The company that has forced the present cut in the price of movements will be held to an accounting by the trade for the injury brought upon it.

---

### Luigi Galvani.

A PECULIAR feeling of awe takes possession of us as often as we read the name GALVANI, the discoverer of the universally-employed galvanic electricity, for which the world owes him recognition, although the discovery was made accidentally, and most strange to say he opposed the new doctrine of VOLTA, and denied with great obstinacy its truth. He is best known as a famous physician and anatomist, and was born at Bologna, Sept. 9, 1737. He evinced a strong desire at an early age to devote himself to a monastic life, and his studies in the University of Bologna were, with this view, chiefly directed to scholastic philosophy rather than to general science. Swayed, however, by the persuasion of his friends, he relinquished his intentions of entering the church and determined to follow the profession of medicine, selecting for special investigation the departments of physiology and comparative anatomy. At this time he enjoyed the benefit of studying under some of the most eminent medical professors of the day—Beccaria, Tacconi and Gallazzi, whose talented daughter he subsequently married. By his knowledge and ability he soon became so distinguished that in 1762 he was elected professor of anatomy in the institute of his native city. His writings are not numerous, but all contain valuable scientific matter.

Galvani owes to a purely casual discovery the wide celebrity attached to his name. Many versions of this circumstance have obtained credence; but the simple fact seems to be that his wife, a woman of penetrating intellect, happened one day to witness with surprise the convulsive muscular movements produced in a skinned frog by its inanimate body having been accidentally brought into contact with an adjoining electrical machine. She hastened to communicate the interesting phenomenon to her husband, who at once instituted a prolonged series of experiments. The savans of those days were busily engaged in trying to discover the "nerve fluidism" or "vital fluidity." He devotedly pursued his discovery with frog's legs, and a second accident in 1768 led him an essential step further. The legs, suspended on a copper rod, had been fastened to the iron rods of the balcony, and whenever the legs happened to touch the iron they became convulsed. Was not this the most undubitable proof of the existence of the "vital fluidity?" Volta, however, soon afterward demonstrated that the cause of the phenomenon was due to nothing else than the contact of the two metals, and that the product of this contact was nothing else than electricity. But Galvani adhered to his opinions; the idea of the "vital fluidity" was so strong within him that he instituted all manners of experiments to prove the correctness of his theories.

It is due to these experiments that Volta so completely formed the doctrine of the "contact electricity," and it is further due to them that Volta was led to the discovery of his Voltaic column. The two defended for a long time the correctness of their individual opinions.

But a heavy blow was in store for Galvani. The French Republic had extended its dominions also over Italy, and Galvani was summoned to take the oath of allegiance after the death of his wife. He refused and was deprived of all his public emoluments, whereupon he withdrew in poverty and deeply wounded in his pride into his brother's house, and slowly wasted away on a consuming fever. Afterward, but too late for him, the government of the republic, in recognition of his ability and merits, voted to restore him to his honors. He died in Bologna Dec. 4, 1798.

Although Galvani does not pertain to those ingenious men who have left to posterity an entire wide domain of science, nevertheless the honor belongs to him of having started two new branches of science. The Galvanic and physiological electricity trace their origin back to Galvani.

### Old Clocks.

THE OLD brass clocks went only 30 hours, and were set in motion by a weight attached to a chain which passed over a sheave having spikes in the groove which caught in the links of the chain and required to be drawn up every day. There was a counterpoise at the other end of the chain, and sometimes a single weight was contrived to serve both the going and the striking parts, and there was occasionally an alarm. On the introduction of the long pendulum clocks seem to have assumed a different character. Catgut was substituted for the chain, and barrels were introduced on which the catgut was wound up, and, a greater length of line being employed, clocks were made to go for eight days instead of 30 hours, and a chime of bells playing every quarter of an hour was often added; the weights and long pendulum hung down, and as there was danger of their action being interfered with, tall wooden cases were made to protect them, on the top of which the movement was placed. This was, I believe, the origin and date of the tall, upright clock cases, which were often made of ornamental woods and enriched with fine marquetry. I have one myself in an early marquetry case, made by Thomas Tompion, with a beautiful set of chimes, about 1690, and it is an admirable timekeeper though it has only the original iron wire for the pendulum rod; and similar instances are numerous. The earlier cases are made of oak and walnut, the mahogany cases being of the following century when that wood was introduced. The brass "button and pillar clocks" seem to have gone out of use about this time, and probably few were made at the end of the seventeenth century; but that will appear more clearly if I receive many communications from the owners of dated examples. With regard to the name of the brass clocks, I have heard them called very many years ago "button and pillar clocks." The meaning and origin of the name I cannot tell, unless it is derived from the pillars at the corners and the hook or button on which the clock may be hung up against the wall.—*Notes and Queries.*

---

### Ancient Ideas Respecting the Origin of Diamonds.

HAPPILY, THE march of civilization slowly but surely dispels with its refulgence the obscurity of bygone ages, and the wondrous fables once entertained by our forefathers, when viewed in the light of the present age, are really too ridiculous sometimes to have been seriously believed to be true by full-grown men of sound judgment. It is impossible for us to even approximately grasp the fullness of the density of ignorance that prevailed three or four centuries ago. These and many more such thoughts occurred to us in the perusal of an old work on precious stones, in which we found recorded with all apparent candor of truth, by one Nicolo Conti, the probable source of diamonds. He says that at Albenigaras, fifteen days north of Bijipur (Bajengalia), there is a mountain which produces diamonds. The method of obtaining them, which he describes on hearsay, is similar to that of the celebrated Arabic myth, which the travels of Sinbad the Sailor and of Marco Polo have made familiar to everyone. The diamonds are collected by throwing pieces of freshly slaughtered cow or buffalo meat into a valley inhabited by venomous reptiles, which pieces of meat, with diamonds sticking to them, were picked up by birds of prey and recovered from them by diamond hunters. Can stupidity go further?

In ancient times sacrifices were offered to the goddess of riches (in India), Ammavaru, and it is very probable that the pieces of meat cut from the victim were thrown about over the ground to serve as peace offering, and naturally were picked up and carried off by the birds. This must have served the fertile inventive mind for a basis concerning diamonds.

Foreign Gossip.

**BURMESE RUBY MINES FOR RENT.**—According to the Rangoon papers, a French mining company lately offered the large sum of 300,000 rupees per annum for permission to work the ruby mines of Burmah. The Burmese government, however, declined the offer, and demanded an annual rent of 500,000 rupees for the monopoly.

**INTERNATIONAL EXHIBITION.**—An international exhibition of metal work is to be held at Nuremberg next year. It will be held in the new museum building, and will contain specimens of the art of the silversmith and the worker in brass and copper, together with the machinery and appliances used in the making of jewelry and art metal work. The exhibition will be open from the middle of June to the end of September.

**TRANSITORY STATE.**—The German gold and silversmiths and jewelers are at present passing through the state of transition from "cheap and nasty," when everything sold at a penny a dozen, and the adjective "bad" was the positive form, to the present substantial, artistic productions. In this state of affairs it is hardly to be expected that the manufacturers of the better class of goods will realize much on their productions.

**SHARPENING FILES.**—The process of sharpening files by means of the sand-blast is exciting universal interest in Europe. Of course, it is next to impossible to re-sharpen old and worn files by this process, but it is said to be excellent for imparting an extra finish to new files, and those that have been sharpened originally in this manner can easily be retouched and sharpened twice or three times after becoming partially dull. Report has it that Krupp, in Essen, is making universal use of such files.

**CONVENIENT MIXTURE FOR PRODUCING COLD.**—In the coming piping hot times, when ice is at a premium, the owner of a parched throat will be gladdened by learning that he can prepare "ice-cold lemonade" by means of the mixture of equal parts of nitrate of ammonia, soda and water, which, it is said, produces a temperature of  $-23^{\circ}$  C., equal to  $-9.4^{\circ}$  Fahr. It has the following good qualities: It does not attack metallic vessels; it is cheap, and can be recovered by evaporating; only a small quantity of water is necessary, and it can therefore be evaporated the more quickly.

—Aluminum is at present employed as a decorative and protective coating for iron and steel against rust, and is highly recommended in place of the nickelizing, tinning or coppering. It is said that the aluminum coating leaves the sharpness of the form of the articles protected with it, adhere, with great tenacity, and that it can equally well be employed upon cast and wrought iron; it can both be ground and polished, and permit an elaboration with the graver. There are many other considerations why it should be preferred to the other metals customarily used, and the fact that aluminum is rather costly will be only a secondary consideration; the first question is its adaptability.

**GERMANY A SERIOUS RIVAL TO FRANCE.**—Germany has entered into a serious competitive strife with France for the leadership in arts and manufactures. A very large, in fact the second largest, carpet in the world, was some time ago ordered by and delivered to the King of Roumania, and he lately ordered an ornamented bronze mantelpiece in Germany (of the firm of P. Stotz, in Stuttgart). Two candelabra-like flower stands, with a plate above, an hour-glass, and two candlesticks, with various breaches, adorn the upper shelf. It is ready for shipment to Sinai, the royal summer palace. Experts pronounce the execution, in the style of the German Renaissance, to be faultless in every particular. This order is the more remarkable as Parisian bronze was hitherto accounted to be the best in Europe, and could base its proud preference on the skill of workmen who, for the last four hundred years, were the leaders of the world, and were backed by the assistance of the State and rich private individuals. Germany has all reasons to be proud of its successful rivalry with the *chef d'œuvres* of Barbedienne and other Parisian manufacturers of bronze.

**DEPRECIATION OF MANUFACTURING PROPERTY IN SHEFFIELD.**—It is a sad but true fact that the English manufacturing interest is going to the "demnition bow-wows." A striking instance of this fact was exhibited at Sheffield last month. The Midland Iron and Steel Works—formerly known as the Cardigan Works—with the file factory, boilers, steam hammers, train of rolls, and, indeed, the whole of the plant, was offered for the fourth time to public competition. The premises (a portion of which is let for about £220 per annum) are situated in the manufacturing quarter—Saville street East—and the land is held under a lease of ninety-six years, from 1863, at a ground rent of £43. In December, 1881, £3,600 was bid for the property, and it was understood that £4,000 could have been obtained for it; in 1882 the highest bid was £2,400; and in 1883 no offer could be obtained. In May, the auctioneer stated that he was about to sell the works absolutely without reserve. The bidding began at £500, and went up briskly to £1,750, at which figure it was knocked down to a party, an iron and steel merchant. The property was valued to the Twelfth Patriotic Building Society at £10,000, and it was mortgaged to the extent of £42,000. "Straws show," etc.

**CELEBRATED NEEDLES.**—The International Exhibition of Needle-work, which was opened on July 1, 1884, at the Crystal Palace, Sydenham, among other curiosities embraces two very interesting objects. One of them is the celebrated sewing needle presented last year, under peculiar circumstances, to the German Emperor. The old monarch visited the large needle factory of Kreuznach to become convinced what machinery, aided by human ingenuity and hands, can accomplish. He was shown a number of extra superfine needles, several thousands of which do not weigh one-half ounce, and he was astonished at the skill necessary to perforate these delicate pieces of human work. But he was destined to behold something more extraordinary. The driller, whose functions is to perforate these needles, solicited a hair from the Emperor's head. It was handed him, and he drilled with the greatest care an eye into it, threaded it, and handed the marvellous needle to the astonished Emperor. The second curiosity is the property of Queen Victoria. This needle was manufactured in the needle factory of Redditch, and represents the Trojan column in miniature. This diminutive needle contains passages from the life of the Queen, but so delicately engraven in relief and so small that a strong microscope is necessary to see them. Beside, this can be opened, and contains a number of finer needles, equally embellished, with relief representations of Her Majesty's life.

**THE TELEPHONE.**—According to a statement published some time ago by the "Compagnie Internationale des Téléphons," 161 cities of Europe have telephones, with 30,066 members; in Asia, 7, with 420; in Africa, 4, with 240; in America, 126, with 47,185, and in Australia, 5, with 897 members. First in rank, therefore, comes America, where to one city come 897 members, while the average figure in Europe is only 187. The 161 cities are divided as follows:—

| States.            | Towns. | Subscribers. |
|--------------------|--------|--------------|
| Germany .....      | 21     | 3,613        |
| Russia .....       | 6      | 1,351        |
| Norway .....       | 2      | 745          |
| Sweden .....       | 5      | 1,554        |
| Denmark.....       | 1      | 516          |
| Great Britain..... | 75     | 7,287        |
| Netherlands.....   | 4      | 1,340        |
| Belgium.....       | 6      | 1,941        |
| France.....        | 18     | 4,437        |
| Switzerland.....   | 2      | 825          |
| Spain .....        | 3      | ..           |
| Portugal.....      | 2      | 80           |
| Italy.....         | 13     | 5,507        |
| Austria.....       | 3      | 870          |

### Workshop Notes.

**TO TAKE SPOTS OFF GILDING.**—Boil common alum in soft, pure water and immerse the article in the solution, or rub the spot with it and dry with sawdust.

**BLACK VARNISH FOR IRON.**—Asphaltum, 1 pound; lamp black,  $\frac{1}{4}$  pound; resin,  $\frac{1}{2}$  pound; spirits of turpentine, 1 quart; linseed oil, just sufficient to rub up the lampblack with, before mixing it up with the other ingredients. Apply with a camel's hair brush.

**WHITE ENAMEL.**—There are many recipes for the making of cold white enamel; it is inseparable, however, from a yellowish sheen by taking simply white color and the usual ingredients. To obviate this, add an atom of black or blue, and the color will at once change to a lively, pure white.

**GILDING WITHOUT BATTERY.**—Articles which do not require much handling, may be quickly gilt without battery as follows: One part of chloride of gold and 4 parts cyanide of potash are dissolved in boiling distilled water, and the gilding fluid is ready; the articles are hung into this hot solution, tied by a fine copper wire to a strip of zinc, scratched clean, left in it for a few minutes, and they will be handsomely gilt.

**VARNISH FOR BRASS INSTRUMENTS.**—An excellent gold varnish for brass objects, surgical or optical instruments, etc., is prepared as follows: Gum lac, in grains, pulverized, 30 parts; dragon's blood, 1 part; red sanderswood, 1 part; pounded glass, 10 parts; strong alcohol, 600 parts; after sufficient maceration, filter. The powdered glass simply serves for accelerating the dissolving by interposing between the particles of gum lac and opal.

**TO RECOVER THE GOLD LOST IN COLORING.**—Dissolve a handful of sulphate of iron in boiling water, add this to your "color" water, it precipitates the small particles of gold. Now draw off the water, being very careful not to disturb the auriferous sediment at the bottom. You will now proceed to wash the sediment from all traces of acid with plenty of boiling water; it will require three or four separate washings, with sufficient time between each to allow the water to cool and the sediment to settle, before pouring the water off. Then dry in an iron vessel by the fire and finally fuse in a covered skittle pot with a flux as before directed.

**MAT BRUSHING.**—Very excellent results are obtained by running the fine wire matting brush at about 2,500 revolutions per minute, applying rain water or sour beer diluted with water at the place where the brush strikes the work; occasionally hold a piece of sandpaper to the brush. Should the points of the brush be too straight, let them strike over a piece of wire, but do not hook them too much, as this would prevent matting. Always preserve the brush in a good condition; should the wires become entangled or twist into knots, separate or cut them out. After the work is matted, take a soft hair brush and brush it in soap water, then rinse it in warm water charged with a small quantity of spirits of ammonia and caustic potash; immerse it in pure alcohol for a short time, and finally dry it in sawdust.

**ARTIFICIAL PEARLS.**—The following process for manufacturing artificial pearls is based on the property of logwood extract and bichromate of potash to form with gelatine a compound insoluble in water: 1. Dissolve in heat 1 part gelatine and 3 parts water; 2. Dissolve in heat 1 part logwood extract in 5 parts water. Mix the two solutions, pour off the excess of water, then mix 1 part of the logwood and gelatine mixtures with 2 parts water. Agitate until it dissolves, and add 8 parts of solution one, so as to have excess of gelatine. Evaporate till small pellicles are formed, then cast in the molds required. After one hour the casting is dipped in a bath containing 1 part of bichromate of potash to 30 parts water, where it is left for five minutes. Artificial pearl of a brilliant black is thus obtained, which is hard and insoluble.

**COLD SILVERING OF METALS.**—Mix 1 part of chloride of silver with 3 parts of pearlash,  $1\frac{1}{2}$  parts of common salt, and 1 part of whiting, and well rub the mixture on the surface of brass or copper (previously well cleaned), by means of soft leather, or a cork dipped in the powder. When properly silvered, the metal should be well washed in hot water, slightly alkalized, and then wiped dry.

**THE OIL STONE.**—Twenty years ago, the oil stone was found only on the joiner's bench, and possibly that of the machinist, and its sole use was the sharpening of the edges of tools. To-day its use has extended beyond this province of edging tools to that of grinding, reducing, finishing, in fact, invading the limits of the grindstone, emery, rotten stone, tripoli, and reaching almost to rouge. This stone, which is a slate brown in science as novaculite—from novacula, a razor,—is cut and dressed in hundreds of varying forms for different purposes. In any hardware or mechanic furnishing store it may be found in all manner of shapes under the name of "slips," adapted for tools of all forms. In dentists' supply stores it may be seen in twenty or more cylindrical and circular forms, and so minute as to be used at a rapid rate of revolution even between the teeth of dental suffering humanity. Some of these cylinders, ovoids, cones, and edged wheels are so minute that a pea looks large by their side; yet they are all veritable grindstones. In the manufacture and finishing of the metals, the oil stone, or novaculite, plays an important part. Our recent exactions as to fits and measures can hardly be filled except by the use of this stone, and it is in demand for truing turned surfaces and planed areas of iron and brass, slowly grinding down the imperfections left by the finish file and the corundum wheel. Recently its powder has largely usurped the place in mechanics' valuation of flour of emery or emery of the higher grades. It is found that a finish "for fit" can be readily obtained by its use in much less time than by the scraper; and that it does not leave embedded particles of quartz or corundum to keep up a perpetual wear. This material is not strictly an oil stone; it is amenable to all of these. Perhaps its best use is with water, especially when the stone is of the harder sort, as the Ouachita.

**GRINDSTONES AND EMERY FILES FOR METAL AND GLASS.**—The manufacture of artificial grindstones is a very simple process, as will be seen by the following: A sufficient quantity of emery powder or crushed quarry sand is stirred in melted shellac, until it is thick enough to be poured into forms. Round grindstones formed from this mass have the advantage that they will give off a heavy dust which falls down, but will not spread in the shop, a result which is not to be underestimated in a sanitary point of view. For the manufacture of large grindstones it is advisable to surround an iron drum, only about 1 inch thick, with this shellac and emery mass; smaller stones are manufactured of it entirely. This composition of shellac and emery may also be employed for further purposes, by not alone using it for grindstones but also for files and similar utensils of different kinds, that may be used with excellent success for the working of glass, brass, iron, steel, soft as well as hard. These files may be used both wet and dry, and in many cases with oil; they replace the usual emery sticks and emery wheels, and many times the costly fine steel files. They are effective upon glass and can be employed for mat filing, wearing down rims, corners, and grinding in holes. The mass of which such files consist is of a dark bluish green color and of a great hardness and firmness; if the substance is exposed to a sufficiently high temperature, it becomes soft and the well-known shellac odor becomes noticeable. It is not necessary to adhere very closely to the mixing proportions of 1 part shellac and 3 parts emery, as the shellac is only made use of for establishing the cohesion between the particles of emery, and therefore easy excess is injurious rather than useful. It will be necessary, rather, to pay attention to the coarseness of the grain; less shellac will be used for coarse than for fine emery, it must not be too fine, and a very uniform grain is very essential.

## Trade Gossip.

Mr. J. N. Miller left for Europe in the steamer *Arizona*, July 26.

The Waterbury Watch Co. will not close their factory this summer.

James Berkley will represent Le Boutillier & Co. on the road this fall.

Silver jewelry is now very popular and is made in a variety of designs.

C. Edgar Righter has withdrawn from the firm of D. F. Conover & Co., of Philadelphia.

Dominick & Haff announce their removal to their new offices, Broadway and 17th street.

Mr. A. Pinover returned July 11 from Europe, where he has been on business and pleasure combined.

The firm of S. Kohn & Co. has been dissolved by mutual consent, S. Kohn succeeding to the business.

E. E. Wilkinson, of Chicago, with the Seth Thomas Clock Co., was in New York recently on a wedding trip.

S. O. Merrill has removed from Morrison, Ills., to Clinton, Iowa, succeeding C. S. Raymond, of the latter place.

Woglom & Miller have received Letters Patent for a new sleeve button known as the "Perfect Sleeve Button."

Thos. Wilkinson, Jr., with Wm. Daue & Co., is now in Chicago visiting relatives. This is his first visit west in several years.

Will. A. Bryant will represent Bryant & Bentley on the road this season with a full line of new goods, succeeding C. A. Boynton.

Fowler Bros. have introduced many new goods this season in English crape stone, among them a very attractive line of bracelets.

Mr. J. M. Morrow, for many years the eastern representative of the Ills. Watch Co., severed his connection with that concern July 1st.

The jewelry store of J. M. Reynolds, at Gouverneur, St. Lawrence Co., N. Y., was burned out July 14. It is reported that nothing was saved.

The French Crown Diamonds are now exhibited to the public in the Salle des Etas at the Louvre. A republican people still delights in such emblems.

Mr. I. S. Lawrence, who has spent many years of his life in the jewelry trade, has been appointed the eastern and New York agent of the Ills. Watch Co.

Henriette Lehmann, wife of E. A. Lehmann, of the firm of Waterman & Lehmann, died July 17th after a long and painful illness at the age of 30 years, 4 months.

Mr. Herman Rypinsky who has long been a resident of Texas, has formed a co-partnership with a A. Friedenthal. The firm will be known as Friedenthal & Rypinsky.

Col. J. M. Rutherford, the able and efficient jewelry auctioneer, is meeting with his usual success this season. He has just had successful sales in Columbus, O., and Johnstown, Pa.

J. J. Cohn, No. 12 Maiden Lane, has procured a patent for a useful eye-glass holder which he calls the "Crown Spiral Eye-Glass Holder." It combines simplicity with convenience.

The Middletown Plate Co. have just issued a new illustrated catalogue which contains all their latest productions, among which are the Fluted designs, of which they were the pioneers.

Jacob N. Bonnet, of the firm of Mulford & Bonnet, returned from Europe in the *Aurania*. In addition to a full stock of diamonds he purchased many novelties in jewelry which they are now receiving.

There was no record last month of the finding of a large diamond or other precious stone in this country. "The times are sadly out of joint." Has the presidential canvass extinguished the champion diamond liar?

A clerk in the employ of Corey & Dorin, jewelers, of Brooklyn, recently robbed his employers of \$1,000 worth of property. He was arrested and pawn tickets for most of the stolen property was found in his possession.

Sumner Blackinton has just returned from an extended tour through Europe, and reports that he saw everything there was to be seen. On the same steamer was John A. McCloy and wife returning from their European bridal tour.

The Fulcrum sleeve button seems to overcome some of the annoyances of lever buttons, having a long post when open and a short one when closed. The attention of the trade is called to the advertisement in this number of THE CIRCULAR.

Street cars run by electricity in Cleveland is the latest development in this line. Various efforts to utilize this subtle force for carrying purposes have been made, but this is the first time a motor has been made open to public use. It is reported to be successful in every respect.

A well dressed man entered the jewelry store of Wm. Hallisey in this city, representing himself as Police Captain Riley, of Jersey City, at the same time making a demand for money. He was arrested and held for trial for attempting to obtain money under false pretenses.

A restaurant at Coney Island has a large placard on its piazza announcing "eighteen carrot vegetable soup." We are glad to know that "eighteen carrot" goods of any description can be obtained at Coney Island. Buyers from the country should make a note of the above.

There are indications that there will be many novel and attractive goods offered to fall buyers. Manufacturers are torturing their brains to get something new, and many of them declare that they "have got it this time." The trade announcements next month will be eagerly looked for by all dealers.

In the July issue of THE CIRCULAR there appeared an article entitled "A New Method of Engraving Cameos and Intaglios." This was a paper read before the New York Academy of Sciences May 25, by George F. Kunz, of this city. In making up our paper the credit was, by accident, omitted.

We have been shown a new watch case which will probably be put on the market soon. It is produced in various colors, onyx, agate and sard, by a process of enameling on nickel. The effect is very fine and the cases ought to be exceedingly popular. The finish is permanent and the enameling cannot be chipped or broken.

Leroy W. Fairchild exhibits in this number of THE CIRCULAR examples of some of his latest novelties in charms for this season which the trade cannot fail to appreciate. The "V" magic automatic cigar cutter is the best article of the kind yet introduced. These goods are all patented, and the demand for them indicates that they will become very popular.

Dr. Hirsch, the Director of the Neuchatel Observatory, in his report for 1883 says that in no previous year have so many watches or chronometers been received or so many certificates given. In 1882 the number of watches was 306, but this rose to 503 in 1883, of which 383 or 76 per cent. have received certificates. During the last five years the number of watches which have passed through the Observatory has more than tripled.

The cholera in France has induced many tourists to turn their faces homeward, and the incoming steamers are bringing back many who abandoned their prospective summer trips in anticipation that the disease would extend over Europe generally. There may be some compensation in this in the fact that if they had no opportunity to spend their money abroad they may be induced to drop more of it in the tills of our own merchants.

We observe that some of our prominent dry goods men, who have been feeling the pulse of trade, predict a good volume of business this fall, but think it will be about three weeks later than usual. This appears, also, to be the general impression in the jewelry trade. The crop prospects are all favorable, and there is apparently nothing to interfere with a prosperous season but the coming election, such events always tending to unsettle trade temporarily.

An association of jobbers has been formed in the west for protection. They have sent a circular to the eastern manufacturers who pretend to sell to the jobbing trade only, requesting them hereafter to sell their productions only to the legitimate wholesale jewelry trade. The organization is composed of the jobbers of Cincinnati, Chicago, Cleveland, St. Louis, Pittsburgh and Indianapolis, and the petition is now being circulated in Philadelphia, Boston and New York.

According to an exchange, another phenomenal diamond has fallen to the lot of a fortunate digger at the Kimberley mine, in South Africa. Its weight is 302 karats; but, unfortunately, it does not possess that purity of color, or rather absence of color, which is the first desideratum in a diamond. Its value is said to be about £3,000; whereas the far smaller Porter-Rhodes gem, found in the same mine about three years ago, was valued by its owner at £100,000.

During the past month many representatives of the jobbing trade of the West have been in New York making their usual Fall purchases. Cincinnati was represented by Messrs. A. Herman, S. Amburg, C. Oskamp, A. Y. Schwob, C. Duhme, A. Plant, L. Strauss. Chicago by H. F. Hahn, O. Sonnenschein, A. Hirsh, A. Shakman, C. H. Knights, C. Wallis, A. Shader, and Stein & Ellbogen. St. Louis by S. A. Rider, S. F. Myers, J. F. Leighton. Cleveland by L. M. Sigler, Bowler & Burdick, J. M. Chandler & Co.

Among the novelties of London jewelry are ornaments made of iron. Berlin once adopted the fashion, but it was during a moment of national pecuniary difficulty, when ladies patriotically brought their jewelry and precious stones to the mint as a gift to the country. The gallant country by and by gave them a pleasant surprise, by sending them fac similes of their jewelry in beautifully cast iron which bore stamped upon it the words, "I gave gold for iron." This iron jewelry is still a treasured heirloom in the aristocratic Prussian families.

Wm. M. Fisher has received his patent papers from Canada, for the new oval split ring for which he received a patent in the United States last March. He is also taking out patents in London, England. The goods are much stronger and better than the old round ones formerly in use, and if the sales for the last few months during the dull season which all manufacturers have experienced are any criterion for the future, he will, no doubt, have plenty to do in the split ring line, having sold over 75,000 in gold and silver so far this year.

Buerk's Watchman's Time Detector has achieved a great success in this country, O. E. Hausberg, the sole agent, having sold over 24,000 of them. This indicates that they give entire satisfaction. The latest improvement in them is the safety lock attachment, which effectively prevents any tampering with it. The case is dust-proof, the movements are very finely finished, having ruby jewels and lever escapement. They have given very high and satisfactory results through all the rigid tests to which they have been subjected, they are the smallest and simplest of the kind in the market.

The Mutual Reserve Fund Life Association, that insures lives on the assessment plan, has taken advantage of the law passed at the recent session of the legislature, and deposited with the Insurance Commissioner the sum of \$100,000 for the protection of its members and as a guarantee of the fulfillment of its contracts. This is the only assessment company in the country having such a deposit. If there are any members of the trade who desire more insurance of this kind than they can obtain in the Jewelers' League, they would do well to consult the representatives of the Mutual Reserve, of which Mr. E. B. Harper is president.

Instances of infringements of patents are of every day occurrence in the jewelry trade. W. H. Ball owns several valuable patents on different forms of jewelry. Recently several articles have been sent to him for repairs, on the supposition that they were of his manufacture. Examination showed that they were bare-faced infringements of his patents, made in the "cheap and nasty" style. Not only is he thus made to suffer by the absolute theft of his ideas, but the impression is conveyed that his goods are of inferior workmanship. In the editorial columns of this issue we have something to say regarding these pirates of patents which we commend to all manufacturers.

July 3d was the third anniversary of the formation of the Willemin Watch Case Company; the event was celebrated by an excursion and dinner at Rockaway, given by Mr. Willemin to the employees of the Company. About sixty persons enjoyed the excursion, and the excellent dinner at the Iron Pier Hotel was enlivened by appropriate speeches, singing, dancing, etc. At the conclusion of the feasts, the excursionists went sight seeing about this famous pleasure resort, and "took in" everything from one end of the beach to the other. The day was a most enjoyable one in every respect, and cannot fail to cement the good feeling that exists between employer and employed.

Among the new designs in jewels is seen a wild rose branch, the rose composed of pink tourmalines, the leaves of diamonds. Three lovely pansies are enameled in purple shades with a diamond in the heart, the long gold stems gracefully entwined together. A bunch of wild violets shows each flower flashing with a diamond dewdrop, and a trembling of diamond dew rests on a cluster of field flowers, a golden buttercup, corn flower and pale pink eglantine in enamel, the pistils powdered with dead gold. A large double Parma violet has intense purple petals that half hide a diamond. Rubies, diamonds and other stones broken into a thousand rays of brilliant light appear in a pin or pendant formed as a trefoil of an enormous tourmaline, a green tourmaline and a ruby sparkling with large diamonds.

According to the daily *Tribune*, D. A. Bowman, of the American Watch Company, thus discoursed to a reporter: "The watch manufacture is a delicate thing to tinker with. It is pretty well established now in this country, but when I was a journeyman I had to walk the streets every time Congress changed the tariff. There are not less than 10,000 people in the country directly dependent on this industry. It has been built up by American ingenuity. The ten thousand workmen here compete by means of machinery with 20,000 in Switzerland alone. Good workmen here can earn from \$18 to \$25 a week, while there they make from \$9 to \$12. I don't think any industry in the country is better established than watch manufacture is now, and I don't think any other trade would be more completely paralyzed, for the time at any rate, by free trade."

We have received the following letter from Mr. Haines, foreman of the finishing department of the Waltham Watch factory at Waltham, which explains itself: "In an item of the July number it is stated that our present stem setting (18 size movement) was a simultaneous discovery by two persons at the same time. This is incorrect, as I invented the same ten months prior to Kortenhaus on his own testimony at the trial in Philadelphia, which the American Watch Company were able to prove. I had my model there from which the present setting was made, and as soon as its success was assured I applied for a patent, which was some time before I knew of Kortenhaus. I would be pleased if you would make this correction and oblige me by a recognition of my invention in your valuable journal."  
H. M. HAINES."

"Notwithstanding the enormous increase in the number of miles of telegraph wire in this country during the past two or three years," says the New York *Electrical Review*, "the business keeps pace with the increased facilities, and promises to outgrow them. The fact is that the people are using the telegraph more and more every day. That the generation which looked upon it as a thing to be used only in emergencies is fast passing away, and that a younger set of men, who believe that time is money and that nothing is more expensive than delay, is fast coming to the front. As business increases it can be done more cheaply, and rates are lowered. This has the effect to still further increase it, and so it grows far more rapidly than the most sanguine telegraph men ever believed possible. We fully expect to see the volume of telegraph business in this country more than double in the next five years, and the estimates of those who are most familiar with telegraph figures fully warrant the expectation."

A man dressed in a blue flannel suit and wearing a policeman's shield went into the jewelry store of Louis B. Mayer, at No. 43 Fourth street, in the Eastern District of Brooklyn recently, and, saying he was from the Board of Health, asked to be shown the condition of the water pipes at the rear of the store. While Mr. Mayer was engaged showing the pipes another man entered the store, and, catching up a tray upon which were seven gold and four silver watches, dashed out again and escaped. The man who had come to examine the pipes also ran into the street. Mr. Mayer followed this man, and calling for help as he ran, a crowd soon gathered in the chase. The fugitive ran into the arms of a policeman. He gave his name as George Kramer, but refused absolutely to make any other statement in reference to himself. He had attached to his waistcoat what purported to be a shield of the New York Police Department bearing the number 610. No description of the man who took the watches could be furnished by the jeweler, who only knew that the thief ran down South Ninth street.

We have received a letter from a firm in Washington complaining of the treatment they had received from a house that makes a specialty of society emblems, badges, etc. It appears that a representative of these manufacturers called on the trade in Washington to solicit orders. Subsequently the firm referred to wrote them, enclosing money, asking for designs for a regatta badge. The manufacturers replied that they could not furnish them as they were negotiating with another person and had given him designs. This other person proved to be an outsider who was seeking the work purely on speculation. The jewelers succeeded in getting the order from the regatta committee but had to take it at net cost. Their complaint is that the manufacturers, after soliciting orders from the retail trade, give outsiders the same privileges and make them competitors. This is an abuse that THE CIRCULAR has frequently called attention to and condemned in no unmeasured terms. It is not likely to be remedied until retail dealers resolutely refuse to have anything to do with the men who thus deliberately seek to break down their trade.



VOLUME XV.

NEW YORK, SEPTEMBER, 1884.

No. 8.

## THE JEWELERS' CIRCULAR AND HOROLOGICAL REVIEW

*The recognized organ of the Trade, and the official representative of the  
Jewelers' League.*

A Monthly Journal devoted to the interests of Watchmakers, Jewelers, Silversmiths, Electro-plate Manufacturers, and those engaged in the kindred branches of art industry.

### SUBSCRIPTION:

To All Parts of the United States and Canada,  
**\$2.00 Per Annum; Postage paid.**

To Great Britain, France, Switzerland, Germany, the West Indies, Mexico, the Republics of South America, and Australia, \$3.00 per annum. Postage paid.

*All communications should be addressed to D. H. HOPKINSON, 42 Nassau Street, New York. Advertising rates made known on application.*

### Goods on Memorandum.

AS THE SEASON approaches for the beginning of the fall trade, and as manufacturers are getting their new styles into the hands of the jobbers, a few words relative to the abuse of the memorandum system that has grown up in the trade will be timely and pertinent. We have heretofore commented upon this growing evil, but our attention is directed to it again by the receipt of several letters from persons interested requesting us to appeal to the retail dealers to consider how seriously they embarrass those who are anxious to serve them by their extravagant requests for goods to be sent them on memorandum.

Probably few dealers comprehend how burdensome this practice has become, or to what extent that which was accorded them as a matter of courtesy and special privilege has grown into an abuse of magnificent proportions. The number of retail dealers in the country is legion, and it is fair to say that nine out of every ten order more or less goods to be sent them every year on memorandum. At first this privilege was cheerfully granted, as it was regarded as a means of aiding small dealers, who could not afford to carry large stocks of goods, and who might be able to secure desirable patrons by having a liberal variety of styles to show them. But what was once regarded as a special favor to them the dealers have come to look upon as their absolute right, and many of them now demand it in an imperious manner, and, if it is not accorded to them to the fullest extent, they threaten to withdraw their patronage from the house that attempts to restrain them in their abuse of courtesy. The extent to which this abuse is carried can be surmised by one who stops to consider the matter, when he thinks that of the many thousands of dealers in the country a majority of them require goods to be sent them on memorandum several times in the course of the year. Such a request must be complied with liberally or offence is taken, and, as a consequence, manufacturers and jobbers frequently have out on memorandum goods amounting in the aggregate to hundreds of thousands

of dollars in value. Consequently they are compelled virtually to carry four stocks of goods—one in the factory in process of manufacture; one in their home office; one in the hands of their travelers, and another loaned out on memorandum to retail dealers. This involves the employment of a large amount of capital that would otherwise be unnecessary, additional risk and much expense. Let us illustrate: At a small country place there is to be a country fair, which excites much interest, and merchants emulate each other in making a display of goods at the fair. The local dealers in jewelry want a liberal display of fresh goods, so they order from the various houses with which they deal, a large quantity of the newest and most attractive goods on memorandum. They are thus supplied with watches, cases, gold chain, jewelry of all kinds, including diamond goods, silver and plated ware, and, in short, a general assortment that will exceed in value their usual stock on hand. These goods are exhibited at the fair for a week, and subjected to not the most careful treatment, and then taken back to the store of the dealer. Having made such a conspicuous display at the fair, he is loth to expose the poverty of his own stock, by returning the borrowed goods immediately, so he retains them a month or more in defiance of frequent letters from the lenders requesting their return. Finally they are sent back, generally insecurely packed, and are found to have suffered serious injury during their absence. Gold cases are found to be scratched, chain is filled with dust and dirt, jewelry is broken from the cards, and in a variety of ways the goods show the effects of their unprofitable journey. As a consequence, they must be sent to the factory and refinished, the jewelry recarded, and various expenses incurred in restoring them to a marketable condition. In one case where local dealers were preparing for a fair, one firm in this city sent on memorandum to a single retailer fifty watches of various styles, in all varieties of cases, gold chain, jewelry, etc., aggregating \$6,000 in value. It was more than a month before they could get their goods back, and then they were accompanied by an impertinent letter, wherein the borrower expressed his opinion that the lender was "in a great hurry to get his goods," and intimated that he should bestow his patronage elsewhere in future. He failed to appreciate his obligation to the jobber, whose goods and capital had been loaned to him without cost for thirty days, and who had to pay all the expressage on the goods both ways, and finally to spend \$25 or \$30 to restore them to as good condition as they were when he loaned them.

Another dealer wrote to a house substantially as follows: "I have a customer for a complicated watch worth from \$400 to \$600. Send me some on memorandum." The goods were sent, and, after the lapse of a few weeks, were all returned, with the information that the prospective customer had moved away. The importer was required to pay the express charges both ways and the insurance on the goods, besides losing opportunities for selling them while they were gone. Such watches are of very delicate construction, and the shaking they get while in the hands of the express company is not calculated to improve them. When these watches were returned it was found

they had been improperly packed, and had rattled around in the boxes till the cases were rubbed to such an extent that the movements had to be taken out and the cases refinished, while the movements themselves had to undergo repairs. The importer estimated the actual cost to him of filling this memorandum order at \$50, in return for which he received not one cent. Importers of complicated watches do not carry great numbers of them in stock, and three or four such orders would exhaust their supply. In another instance, 47 gold cases, of the latest patterns, were sent to a dealer on memorandum, who finally returned all but one, and grumbled because a "greater variety" had not been sent him. Not a day passes but manufacturers and jobbers are required to send out valuable goods on memorandum, and some retail dealers rely almost exclusively upon memorandum goods to "liven up their stocks" and give a generally attractive appearance to their establishments. Many who thus obtain goods are not only impertinent in their manner of asking for them but they are careless of the property entrusted to them, do not offer to share the expense to which the lender is put, and, apparently, make little effort to dispose of the goods after they get them, but, having displayed them for a time for their special glorification, return the whole or the greater part of them without a word of thanks or recognition of the courtesy shown them. The abuse is especially felt in regard to diamond goods. So great has this burden become to the wholesale trade that manufacturers and jobbers feel compelled to place some restrictions upon it. The desire does not appear to be to abolish the memorandum business entirely, but to curtail its proportions considerably, and to require those who are exclusively benefitted by it to assume some portion of the responsibility and expense inevitably connected with it. It is the abuse of the practice that is protested against rather than the practice itself. If dealers realized the full extent of the inconvenience, to say nothing of the expense, the wholesale trade is subjected to in consequence of the extravagant memorandum orders they send in, we are certain they would be less exacting. No one of them stops to think that there are thousands of others making similar requests, and that if the wholesale trade undertakes to comply with them all the burden will be greater than they can carry. If the retail trade will be as light as possible in their requests for goods on memorandum, return promptly and in good order such as they do not care to keep, the wholesale trade will meet them in a liberal spirit and do their utmost to accommodate them.

---

### Spanish-American Markets.

**D**URING THE recent session of Congress an act was passed authorizing the appointment of a roving commission for the purpose of devising some means by which our people can cultivate "more intimate commercial relations" with South and Central America. In accordance therewith the President has, as it was intended that he should do, appointed certain politicians to do this international cultivation, and they have already started upon a picnic at the expense of the government. No one probably ever anticipated that a junketing party of this kind could do anything practically towards establishing "more intimate commercial relations" with the Southern end of this continent. They will go down there, have a good time, talk over with some of the natives some theoretical ideas on the subject of commerce, and then return home, submit a glowing theoretical report, draw their pay and sink once more into commercial insignificance. Commercial relations are not established by "High Joint Commissioners." They are the outgrowth of supply and demand, those two great factors that are all powerful in whatever relates to commerce or manufactures. What the people want in the way of material things they will have, and they will buy them where they can be obtained for the least money. There is no sentiment or politics in business. If our trans-atlantic competitors have the bulk of the South American trade, it is

because they can put down their goods there cheaper than we can, not because the South Americans have any greater affection for them. Give our merchants the same facilities for manufacturing and transporting our products that their competitors from over the ocean have and they will beat them in any country, for they have more enterprise and vim. Instead of sending out picnic commissioners on "fools' errands," Congress should give us such legislation as will remove some of the tariff restrictions imposed on the raw material used in our manufactures, and such of the obstacles in the navigation laws as effectually prohibit the building of American ships. Let Congress put our enterprising manufacturers and merchants on an equal footing with their competitors for the commerce of the world in procuring the material from which their specialties are made, and equal facilities for their transportation, and our commercial relations with South America, and the rest of the world, will speedily grow more intimate and more profitable.

The Republican candidates for President and Vice-President have, in accepting their nominations, dwelt upon the fact that the commerce of the country should be extended. This is a point upon which they will find themselves in accord with all business men; where they will find differences of opinion will be as to the political party and the methods to be used to secure the desired result. Whatever will secure new markets for the surplus productions of this country will add new impetus to industrial enterprise, give employment to idle capital and work to the great army of unemployed. To exchange the products of industry readily for money is prosperity, and this is what all are seeking. The several nations of South America stand in need of many things that are produced in the United States and in Europe, and that we have not had our fair share of their trade is due to the restrictions imposed upon commerce by our own laws and not because of any special enterprise on the part of our competitors. In alluding to the existing condition of affairs, Senator Logan, in his letter accepting the nomination for Vice-President, said: "Diplomacy and intrigue have done much more to wrest the commerce of Spanish America from the United States than has legitimate commercial competition. The best method to promote uninterrupted peace between one and all would lie in the meeting of a general conference or congress, whereby an agreement to submit all international differences to the peaceful decision of friendly arbitration might be reached." The sentiments here expressed are something of a popular delusion but they should not be shared by statesmen of intelligence. If our politicians think to obtain for us more "intimate commercial relations" with our South American neighbors by "diplomacy and intrigue," they will be apt to lead us a long and weary race for new markets. The Brazilians, Peruvians, the Chileans and Central Americans stand ready to buy of us whenever we can lay them down the goods on better terms than they can get elsewhere. They are not imbeciles to buy in the highest market for the sake of indulging a sentiment. "Diplomacy and intrigue" have no more effect upon supply and demand than they have upon the tides of the ocean. They may affect prices, but those who buy and sell are the ones who determine in what markets they will transact business, and with them it is a simple question of self interest. If the commission that has been sent to South America to lay the ground work for "more intimate commercial relations" with that section, will have the good sense to say to Congress, "the power to control those markets in the interests of our manufacturers rests with you," its junketing will not have been in vain.

There is no doubt but a large portion of the trade of Spanish-America that now goes to Europe ought to be controlled by our merchants; we hope it will be before many years have passed. Should our merchants ever be placed on a footing of equality with their trans-atlantic competitors, it will be worth millions of dollars to the jewelry trade of this country. The trade possesses manufacturing facilities in excess of the demand for their products, and new outlets for these would be a blessing. But these markets will never



be opened to us by the special efforts of either political party or by the stump speeches of candidates. What will accomplish it will be the influence of the American people brought to bear on Congress that will force their representatives, regardless of party, to unite in securing such modifications of our laws as will give American industry an equal chance with all competitors; "a fair field and no favors" is all that is required.

### The History of Goldsmithing.

*Continued from Page 212.*

**T**HE SIZE of the vessel is ten inches and it weighs three pounds. This admirable piece appears to have been manufactured in the first years of the third century, and it would be difficult to find another piece that could be at all compared with it.

As specimens of silversmithing of Roman origin, the Cabinet of Antiquities, among other pieces, possesses a magnificent collection of objects which were discovered some fifty years ago in a field near Bernay (department of the Eure), by a poor farmer who was cultivating his acres. The treasure does not consist of a few random pieces, but of more than sixty objects of silver, among them several statuettes, several of them of fifty-five pounds weight; vases, plates, and utensils of all kinds. It is generally believed that this treasure is a part of the possession of a temple of Mercury which once stood in this neighborhood.

One of the more important pieces of the find is the silver statuette of the god himself, of a height of twenty-two inches, and, as it is wrought of the solid metal, it is sole of its kind. Its style of execution is faulty, however.

Another statuette of the same god was found in fragments, and the pieces were very artistically joined together by a modern silversmith. The reconstructed figure, although smaller, is finished in a far better style than the former.

Another very remarkable feature of the treasure of Bernay is the collection of pateras and vases of different sorts.

Among the most remarkable vases must be mentioned a beautiful pair, of which we append the cut. They are in strict conformity with the severe rules of style, and an art connoisseur does not hesitate to place their manufacture to the dawn of the Roman Empire. The subjects are borrowed from the Trojan war. One of them represents, on one side, "Achilles weeping over the body of Patrocles," and the other "the recovery of the body of Hector," and on the neck of the vase "the raising of the palladium." The second vase shows on one side "Achilles dragging Hector's body behind his chariot," the other "the death of Achilles," and upon its neck "Ulysses and Dolore." The handles, which terminate in Medusa heads, are decorated with ornaments chased in the body. The vases are twelve inches high, and measure seventeen and a half inches in circumference.

To the same group belong two votive vases, representing bacchanalian subjects, chased upon small silver leaves. These two vases much resemble each other in their ornamentation and work, but differ essentially in shape. They belonged, doubtless, to the same votive offering, and, therefore, must be considered as contemporaries.

Several of the other pieces, vases, plates, cups, spatulas, etc., composing this treasure contain inscriptions, whereby archæologists are enabled to very closely approximate their age, and it is the general opinion that the oldest of these objects date from the first years of the Roman Empire, and the last ones belong at least to the third century of our era. These inscriptions are very interesting, because the oldest are Roman names, while the more recent ones are purely Gallic, an additional proof that during the first centuries Roman art had already spread in Gaul.

Roman art, however, did not last long, and many causes contribu-

ted to its downfall. An excess of luxury and of wealth invariably ends in deteriorating the purity of style. In order to satisfy the "bloated" aristocrats the artist is obliged to produce something extraordinary, to leave aside the severe forms of beauty and adapt them to the pampered taste of "mushroom" shoddyites. And no one can deny that this state of affairs was especially true for Rome. Hence the decay of its art and science.

But the art of goldsmithing was to be purified by another unlooked-for occurrence. Emperor Constantine had been converted to the Christian faith at the beginning of the fourth century, and, full of religious fervor, he founded Constantinople.



FIG. 3.

When Constantine embraced the new faith this was, so to say, still in its infancy, in its nascent state, and by his conversion it issued from the catacombs of Rome, where it had hitherto been ensconced, into the broad light of day, and occupied a place near the throne of a mighty emperor. It suddenly bounded from a retired simplicity into a state of sumptuousness. Constantine, who, by founding a new city on the ruins of Byzantium, simply believing to found a second capital, at once created a new empire and inaugurated a new civilization.

Rome, when Constantine bid it farewell, had no cause to complain of his niggardliness. Anastasius the bibliothecary informs us that alone among the several churches of the eternal city he caused to be distributed three or four thousand pounds of gold, and more than thirty thousand pounds of silver. Saint John of the Lateran received for its part one thousand and seventeen marcs of gold, partly consisting of a large lamp ornamented with dolphins, weighing twenty-five pounds; four votive crowns, of the weight of fifteen pounds each; seven plates, of thirty pounds; fifty chalices; two large vases, and an infinite variety of pieces of silversmithing. But the most important piece of this gift was a large ciborium or baldachin (cover for the altar), accompanied by eighteen colossal statues representing Jesus Christ, his apostles and angels. The same historian also men-

tions that Constantine placed a large cross of the weight of one hundred and fifty pounds upon the grave of St. Peter, and another similar one upon that of St. Paul.

This was the commencement of Christian goldsmithing.

But let us leave the Rome of the Cæsars to follow the fortunes of Constantine in his new capital. We will return after a time to the Rome of the Popes.

## 2. THE EMPIRE OF THE ORIENT.

It was not a small undertaking to found a new capital capable of being a rival to Rome. The student of history will be struck with the marvelous order adopted by Constantine to accomplish his ends. Barely a few years sufficed to construct the bastions of the city, and to erect edifices of all kinds that should contribute to the splendor of the city: an amphitheatre, a circus, a palace, markets, porticos, and last, but not by any means least, to erect and endow numerous new churches reared to a faith which the emperor himself substituted to that of the false gods.

Among the most magnificent and celebrated it is necessary to first cite the temple which he erected to Divine Wisdom (Saint Sophia), and the church of the Holy Apostles, which he chose for his sepulture. The choir of the latter was surrounded with bas-reliefs of bronze damasked with gold. At St. Sophia Constantine caused to be erected a magnificent column surmounted with a cross enriched with jewels, in the form of the supernatural cross that had appeared unto him in the heavens. Besides this, various gold crosses of the same form were erected in the throne salon of the imperial palace, and at several places in the city, at the Forum, the Philadelphion, etc. Finally this same miraculous sign was placed also upon the *labarum* (sacred standard) adopted by Constantine.

At the same time he regaled the churches of Asia, Antioch, Nicosia, Bethlehem, and the Holy Sepulchre of Jerusalem most munificently, presenting to them a number of pieces of goldsmithing of a great value.

Constantine, when alive, was the first emperor who wore a crown of gold decorated with pearls and jewelry, and, when dead, was the first who was buried in a coffin of gold.

His son Constance, less illustrious than the father, was not less lavish, however, nor was his munificence toward the churches less. The decoration of the church of St. Sophia was finished in a sumptuous manner during his reign, and still more so under that of Theodosius, the art of goldsmithing, as applied to profane as well as religious uses, was brought to a high state of perfection at Constantinople. According to contemporaneous historians, the city was overfilled with goldsmiths, whose sumptuous shops displayed objects of untold value, so that the austere John Chrysostomus, at that time patriarch of Constantinople, is forced to exclaim that there is more attention paid to the works of the goldsmith than to matters of religion.

The works of the goldsmith began to introduce itself into the details of wearing apparel, which at this epoch underwent a complete alteration, as can be seen from the beautiful plate,\* figure 4, found at Amendralejo, Spain, and which represents Theodosius seated between his two sons with whom he shared in the government of his empire.

To the diadem ornamented with pearls and jewels, which was first adopted by Constantine, his successors soon joined pendants attached by chains to the head hoop of the crown. To the simple toga, in which the Roman emperors clad themselves, they also added a long robe of silk of bright colors and woven with gold, and studded all over with the most precious of jewels.

Goldsmithing was most decidedly driven into a corner. Hereto-

\* This beautiful piece of goldsmithing of the fourth century is beyond a doubt of Byzantine workmanship. The Latin characters of the inscription only prove that it was destined for one of the western provinces of the Empire. Apart, even, from the style of the figures, the Greek characters (undoubtedly the private mark of the goldsmith), to be seen on the reverse of the plate, suffice to prove that it is the work of a Byzantine workman.

fore it had been able to manufacture something to the honor and glory of one of the thousand and one gods and goddesses, but when these were swept out of the field by Christianity its horizon was most woefully contracted, and attention was therefore bestowed upon erecting statues to the mighties of this world, and bronze being rather a cheap article, silver was frequently employed; for instance, a silver statue of the weight of seven thousand pounds was erected upon the Augusteum in memory of Theodosius the Great, and at various other cities throughout the empire colossal statues, always of silver, to Empress Eudoxia and her three daughters, were reared.

Justinian, a successor of Constantine, is considered to have been the greatest patron of the goldsmith. He may well be excused for his lavishness, because contemporaneous authors state that he found three hundred thousand pounds of gold in the imperial treasury on his accession to the throne.



FIG. 4.

The most celebrated monument of his age was the church of St. Sophia, which he rebuilt completely. Not alone had the primitive edifice, built perhaps with too great a haste by Constantine, become a prey to the flames, but also the new temple of Theodosius, built upon the ruin, was consumed in a like manner. Justinian resolved to reconstruct the edifice on a new plan, and make it fire-proof, and to him is due the magnificent construction, with numerous cupolas, still in existence, which has served since that time as prototype of Byzantine architecture.

It is useless for us to attempt to give a description of the edifice, as it is irrelevant to the purposes of THE JEWELERS' CIRCULAR, and we will merely confine our remarks to stating that this new religion, owing to the rapidity with which it had spread throughout all parts of the empire, necessarily imprinted on goldsmithing entirely new features. Everything was changed; everything was to be remodeled. The sacred vases were no longer the same, and had to be reconstructed in order to conform with the new order of things. The new styles of vessels, either for civil life or devoted to religious purposes, possessed a great deal of uniformity, and the ingenuity of the goldsmith had to be brought to bear to ornament them with chasing, engraving, enameling, incrustation, etc.

It is equally foreign to our history to quote all the reports of ancient authors, for instance, Bishop Luitprand, who had been an ambassador at Constantinople during a part of the tenth century. He records that in one room he saw eleven beds of gold; in another, the hall of the throne, twelve trees of gold, in which gold birds fluttered their wings, while two life-size gold lions lay before the throne, and at intervals roared and raised up on their feet, etc.

(To be Continued.)

## Jewels and Jewelry.

IT APPEARS that jewelry in some form or other has been in use from the earliest ages—from the time that Eve adorned her person with an apron of fig leaves, the brain of woman was busy devising means to improve and increase her charms; whether Eve wore any other jewelry we are not informed; whether she tried to further bring her husband under her control by trimming the aforesaid apron with shells from the sea or other ornament is still a problem, but that the earliest form of jewelry for the purpose of personal decoration was in the shape of fantastically shaped shells found in the bed of rivers, etc., there can be no doubt, and among savage tribes they are yet extensively used.

The terms Jewels and Jewelry, in their strict signification, are applied to precious stones set in gold and silver and worn as personal ornaments, but from general usage any article made from the precious metals is classed under the same heading. From the earliest ages, from the savage tribes to highly civilized nations, the taste for jewelry has characterized the human race. From the earliest times, ornaments for the person were among the first subjects for human ingenuity. Shells, dried berries, small perforated stones and feathers of various colors were combined to adorn the head, neck, arms, fingers and toes, while the cartilage of the nose as well as of the ears, was perforated for the suspension of ornaments, and while in the present enlightened age we may smile at the simplicity of these forms of jewelry, yet when the belle of one of those ancient savage tribes received from her lover a necklace of shells, dried berries, small perforated stones, feathers, etc., as a Christmas present, she knew they were all right, she did not have to endure the agony of mind, which modern belles have to endure, till they can run around to the nearest jeweler to find out whether they were genuine, and whether 14 or 18 karat fine.

But the use of the precious metals for jewelry is also of a very remote antiquity, undeniable proofs exist that the ancient nations had developed the art of goldsmithing to a very high degree of perfection. Finger rings were probably the first forms of jewelry made from the precious metals. The use of signet rings as symbols of great respect and authority is mentioned in various parts of the bible and it would seem as if they were only worn by kings, princes and people of high rank. They were sometimes wholly of metal but frequently the inscription was cut on a stone set in gold or silver. The impression from the signet ring of a monarch gave the force of royal decree to any instrument to which it was attached; hence the delivery or transfer of it gave the power of using the royal name and created the highest office in the state. In Genesis, chapter 41, we find that Joseph had conferred upon him the royal signet as an insignia of authority. Thus Ahasuerus transferred his authority to Haman. (Book of Esther.) In the tombs of the kings, in Egypt, have been found many specimens of the manufacture of jewelry by that ancient people, some 2,000 years before the Christian era, which show remarkable ingenuity and mastery of the art. They include hammered work, engraved and chased work, the evidence of soldering chains of fine gold wire, closely plaited and very flexible and of remarkably excellent workmanship. There is in South Kensington Museum an Egyptian Signet containing 20 pounds of gold. It consists of a massive ring  $\frac{1}{2}$ " in diameter, with an oblong crest; on one side was the name of a king, the successor of Amunoph III., 140 years B. C., on the other a lion, scorpion and crocodile. The Bible and many historians of the Greek speak of this rise of the art of goldsmithing among the old cultured nations. Solomon's Temple glittered in the pride of gold adornment; 666 hundredweights were used for its embellishment. Homer exalts the golden arm of Glaucus and the exquisite inlaid shield of Achilles. Semiramus caused gold and silver statues to be erected, and the greatest of all Greek artists, Phidias, was a goldsmith, who built temples and in them set statues of the gods in hitherto unknown perfection. In Sycion, Samos, Corinth and Athens most excellent goldsmiths manufactured those vessels, ornaments and masterpieces for which the Romans after-

ward paid incredible sums and which we marvel at to-day as the proof of the eminence of the art. The discoveries of Dr. Schlieman at Mayence and Hissarlik, supposed to be the site of ancient Troy, supplied numerous illustrations of the state of the art at the time of the Trojan war, about 1,200 years B. C. The objects found embraced most of the styles of personal ornaments still in use and gave evidence of singular skill and ingenuity in working the gold, and in combining the various parts of the article.

The goldsmith in his production characterized the grade of culture both of his people and age. During the flourishing period of Greece, we find the goldsmith's art upon the highest pinnacle; generally it descended commensurate with the increase of ignorance and wars, and finally the sun of culture sets behind them. Greek etruscan and early Roman ornaments of gold and of a date varying from 1,000 years to 100 B. C., have been found of a character which modern gold workers can by their best skill only rival, and hardly, if ever, surpass; while in later Rome, where the conception of the ideal languished and perished, in the viciousness of the emperors and the brutality of the people, the goldsmith finally becomes the panderer simply for the senseless, beautiful lavishness, and his art becomes nothing else than a more and more degenerating imitation of Greek works. To a certain degree this is true of the jewelers' art to-day. Hiliogabalus adorned his rooms with gold, only dined from gold plates, filled from massive silver vessels, which he presented to his companions while the hungry multitude stood before his palace crying for bread. He caused gold dust to be strewn in his path in order to show that as the first in Rome he could afford to waste its possession and its blood. But true art had no companionship for such senseless extravagance, and after a night of many centuries the spread of Christianity once more awakened the jewelers' art to some of its former glory.

From the 5th to the 8th centuries of the Christian Era, the Franks, the Anglo-Saxons and the Celts manufactured jewelry of distinguishing features. Proof exists that the Saxon jewelers and workers in gold and silver were eminent in their art in the reign of Alfred the Great, while the Celtic ornaments found in Scotland and Ireland were, some of them, hammered work with detail in *repoussé*, filled in with amber or rock crystal, not cut, as the art of cutting had not yet been introduced, but highly polished; others were of minute filigree and plated work in combination with niello and enamel. Of Mediæval Jewelry, from the 10th to the 13th century very little is known, and rings are the chief specimens yet existing, some of them very massive and elaborate. It is probable that during this time—the time of the Crusaders—wars engaged the attention of the people to such an extent that all the arts, except the art of war, had to suffer. But after this time a reaction again took place, and in the 14th, 15th and 16th centuries jewelry was worn with more luxury and extravagance than ever. Great prodigality had become customary among the courts of western Europe and among their noblemen in France, Spain, Germany and Italy. The elaborate display of personal ornamentation since the days of the crusades proclaimed the high self estimation entertained by the princes and knights, which was shared by the free and wealthy citizens of the country. Gold was the word; gold was desired by all. The goldsmith had good customers, and his work was the representation of the period. At first he laid more stress on the solidity of his wares, while gradually, when the people became more refined, he became more ambitious, stimulated by the growing culture and refined taste, of producing the most admirable masterpieces. Table service proclaimed the wealth of a family, together with gigantic beakers and drinking cups surfeit of ornamentation in attire, necklaces, rings and spangles. The knights were encased in gold and silver armors beautifully engraved with the most delicate interlacings of Arabesque or inlaid with gold. This prodigality in dishes and personal ornaments was fully sustained by the sumptuousness in eating and drinking. When Duke Charles the Bold, of Burgundy, in 1473, traveled to the diet at Trier, his suit consisted of 5,000 well armored and

mounted men. He himself was dressed in a gold dress studded with pearls valued at \$200,000. He invited the Emperor, Charles V.; and Hans Sachs, the chronicler of the festivity, says that at the dinner entertainment all the dishes were of silver and the beakers and cups were resplendent with jewels and pearls. Four courses were served, the first of which consisted of 14 the 2d of 12 and the 3d of 10 costly covers. For the fourth 30 gold vessels were served filled with spices and confectionery; the largest dish was estimated at about \$2,000. Berlepsch said that Elector Moritz caused 450 pounds of silver to be manufactured into dishes intended for the marriage of his son, the future King, August of Poland, with a princess of Denmark. King Sigismund of Poland and Sweden in 1606 presented to his bride a dinner set of pure ducat gold 22.6 karats, the cost of the manufacture alone of the water basin with water (for washing hands after meals) was valued at \$8,000. The attire of the bridal pair represented a value of \$700,000. The king wore fine diamonds estimated at \$1,000,000 in his diadem.

Berlepsch relates the almost incredible story that towards the end of the 16th century the prodigality in gold and silver vessels were so great in Spain that a man called himself poor if he did not possess at least 800 dishes of the noble metal. It is said that many households had as many as 1,200 dozen of heavy plates and 1,000 dishes. The treasures of the recently discovered America were utilized in this manner in European luxury. According to the chronicles of Sevilla the Spaniards brought 1,336,000,000 ounces of gold into Spain between the years 1519 and 1617. But as an offset to the luxury of Western Europe, all the arts had retrogressed so far in England that the Barons had not even tinware upon their tables, but drank out of wood or leather vessels, wherefore it was said out of irony that the English got drunk out of their boot shafts.

The goldsmiths of Western Europe, above all, the French, sought to commingle with this taste for luxury in dishes and excessive indecency, and combined their productions with voluptuous representations, especially their large drinking cups and goblets. Only to give one instance: Philip the Good of Burgundy caused a female statue of gold to be made from whose breasts issued the wine at table, and a young girl of enameled gold in nearly the posture of the Venus of the capitol, a fountain of the purest wine issuing from under her modestly folded hands. Finally the extreme to all this luxury was reached and it was resolved to counteract this senseless dissipation and luxury with extreme laws. The nobles had become impoverished thereby and they resolved in 1479, at the 28th great tournament held at Wurtzberg to adopt a sumptuary law by which all gold ornament, both in attire and armor, was prohibited; nor were the women excepted. Charles V. in 1530 issued a law forbidding country people from wearing any jewelry whatever; the citizens might wear a gold ring without jewel of the value of 5 or 6 florins (about 35c.) and their wives a girdle up to 10 florins; merchants' wives one of 10 florins; their daughters and unmarried ladies a head-dress of 10 florins; rich city councilors could sport a ring of 50 florins; noblemen could adorn themselves with a chain of 200 florins and real knights up to 400; counts and gentlemen might expend 500 florins therefor and their spouses as much as 600 florins. The goldsmiths were prohibited from employing the noble metals uselessly for articles of ornamentation, nor could they sell valuable articles to persons of low degree.

While these laws prevented the common people from wearing jewelry, the noblemen could obtain most anything from Nuremberg, Germany, which had become the rival of Florence in productions of art. Wenzel Jamtizer in Nuremberg and Benvenuto Cellini in Florence were the two masters of the art of goldsmithing in the 16th century; the former of the two finished works of so delicate a construction that when the breath was blown against a blade of grass made of gold it moved. Many of his works still exist in the art collections of Dresden, Berlin and Vienna. It was at this time that the art of goldsmithing reached its highest point of development; the goldsmiths of the Italian republics produced work with the use of

enamel, niello work and engraving in combination with skillful execution of the human figure and of animal life, producing effects which modern art is not likely to approach much less to rival. But since that time the causes which have led artisanship in all the trades to decline, through the introduction of the factory and machinery systems, has also had a demoralizing influence on the art of goldsmithing. The past century has not given birth to a master who could lay claim to an immortal name by reason of his artistic conception and skill. From the French Revolution, whose influence extended over the whole world, dates the decline of the art. The desire of the workingman of that period to equalize all class differences, the lowering of that social culture to the level upon which this equalization, this compensation, was to take place, was characterized by the gold trinket of that time. Those formerly debarred from wearing jewelry, either by laws as mentioned before or by poverty, now craved it, it being placed nearer their reach, and purchased that quality that could be furnished at a low price without artistic pretensions and as a cheap bauble. The main question was its gaudy appearance and its cheapness. The middle class citizen and the proud aristocrat who had become impoverished, but still desirous of retaining the ancient distinctions of their class, were satisfied more with the appearance than the real value of the trinket they wore, and the question with the goldsmith became not how much art and skill he could lavish upon it, but how cheaply he could make it. Solid silverware degraded more and more into sheet silver and engraving was superseded by stamps and dies. Chemistry, which once had conjured up all the lore of the secret arts in the manufacture of pure gold, now as diligently strove to undermine it by producing spurious gold and silver that would meet the common wants. To substitute gold by some other glitter and gloss, it furnished German silver, Britannia metal, brass, the art of gilding, electro and roll plating and many other devices to replace the noble metals. Such substitutes found a prodigious market, and, of course, all such things as art in manufacture disappeared. The goldsmith no longer engraved gold in self-conceived artistic designs, but delegated the task to the factory to pander to the low ideal and vulgar tastes of the multitude—to produce it with their presses, dies and stamps by the dozen. The markets of Paris flooded the world with these inartistic patterns and they found a ready sale. This degradation in the art of goldsmithing reached its lowest point about 20 years ago. It was brought about by natural causes. The four classes of the world were being released from the bondage of centuries and cheap jewelry was naturally patronized extensively by them. They had not the money nor the necessary taste to procure such elaborate specimens of art as the noblemen of former centuries, and among the wealthy the tendency had been to invest most of their money in precious stones instead of spending it on gold decorations. These two causes led to the deterioration of the art. Germany, which had led the world in art, then flooded the world with the most abominable trash from its Pforzheim manufacturers. Eight karat gold and filled with lead solder was the distinguishing feature of its manufacture. They flooded the American, Cuban and South American markets and helped to deprave the taste of the people. France sent a corresponding lot of jewelry throughout the world, and, while not being quite as bad as the German, yet they possessed the art of rolling out their gold so thin that their jewelry would scarcely bear looking at. The United States factories attempted to imitate them but failed because they could not work with such thin gold as the French. But a reformation began to pass through the art about 20 years ago, emanating from Italy and caused by the finds in Pompeii. The artistic shapes of these articles again attracted attention to antique styles and business found it pay to imitate them. Chased ornaments are again demanded, but while Pforzheim jewelry has almost disappeared from the market yet the prevailing absence of a well defined style of the 19th century is painfully apparent. The many expositions and world's fairs have glaringly established this truth, and a contrast between the old and

the new was very unfavorable to the latter. But we are evidently now in a transition period. The demands of the day are too great to return to the slow hand labor of the Etruscan, Louis, Rocco or any other style of the past centuries though first-class artists were in abundance. But the time will come when some Jamitzer or Cellini shall blend these styles with those of machinery and reduce them to a harmonious whole.

The great centers at the present time of European art are Paris, Vienna, London and Birmingham. Of these Paris takes the lead, having in 1876 about 900 manufacturers and selling goods to the amount of \$12,000,000 annually. They have a bureau there where all new jewelry is chemically tested with great care; 3 grades are allowed by law and are indicated by official stamps. The English have endeavored to secure a standard of quality for jewelry in what is known as the Hall Mark. This stamp has been recognized by law for over 400 years. It was established by the Goldsmith's Company, one of the 12 Livery Guilds or associations of tradesmen enjoying certain special rights in England under royal charters granted in the 14th or 15th centuries. It was chartered in 1327 by Edward III. It was invested in 1462 by Edward IV. with the privilege of inspecting and testing all gold and silverwares in the kingdom, with power to punish all offenders concerned in working adulterated gold or silver, and in 1505, Henry VII., they had additional power to compel the trade to bring their work to the Company's hall to be assayed and stamped, and gave the power forever when it was not standard to utterly condemn the same. This was the origin of the Hall Stamp and has been on the whole an effective protection to purchasers of these goods, and a movement is on foot among American manufacturers to introduce a similar stamp here.

In this country during the colonial period, the wearing of jewelry was discountenanced in New England and among the Friends of Pennsylvania and New Jersey, by whom, as well as by the Puritans, jewelry was regarded as one of the devices of Satan, and except what was brought from England by wealthy immigrants little was worn and there was no demand for its manufacture. In the last century there were a few gold and silversmiths in Boston, New York and Philadelphia who made to order only a few smaller articles of jewelry, such as making of guineas and dubloons into beads, finger-rings, watch seals or chains, but the making of jewelry in its variety and on a scale which could be called a manufacture, was not attempted until 10 years after the Independence of the colonies had been secured. The manufacture of jewelry was commenced at Newark, N. J., in 1790, by Epaphras Hinsdale on a small scale at first but with gradual developments till his death in 1810. He was succeeded by an ingenious mechanic named Taylor, who invented various machines for facilitating its manufacture. The manufacture at Providence, R. I., was begun in 1794 by Nehemiah Dodge, and in 1812, Marchais la Grave, a Frenchman, established the first shop in the city of New York, at 190 William street; he was the only manufacturing jeweler until 1821, when others appeared upon the scene. Jewelry manufactured in this country as well as in Europe may be classed under 4 heads: 1st. Articles in which gems form the chief part the gold work serving only as means to carry out the design. 2d. Those in which gold is the principal feature, the precious stones being subordinate and for the purpose of decoration. 3d. Those in which gold of various degrees of fineness is the material either hammered or struck from dies in *repoussé*, cast, engraved or chased, or left absolutely plain but highly polished. 4th. Filled or plated goods. The gold used in the first 3 classes is of fineness from 10 to 18 karats. The term karat is applied to the weight used in weighing precious stones, being equal to 4 grains Troy; applied to gold it means so many 24th of pure gold. Thus, gold of 18 karat contains 18 parts of pure gold and 6 parts alloy. The alloy is copper or silver and the tint of the gold will incline to red or to yellow as the proportions of the former or the latter are increased. Gold alloyed with a little cadmium gives a greenish tint. An addition of steel gives a gold of gray and by certain proportions a blue color. Pal-

adium gives a brown color, and by the employment of these alloys the goldsmith is placed in the position of manufacturing very handsome gold ornaments without the use of enamels or other colorants, by using an underlay of pure yellow or white gold as a backing of the colored gold. Other effects in colors are by applying the gold to different degrees of heat but these colors are not lasting. The process of producing Roman or colored gold, which is probably the only distinctively modern finish we have, is by alloying the gold with copper, and after the article to be colored is finished it is dipped for a few minutes in a solution of nitric acid which eats out the copper on the surface of the article, and leaves only the pure gold visible on the surface and leaves it of a beautiful yellow color. By constant wear the pure gold will wear off and the alloyed metal will come again to the surface ready to be re-colored once more. The hardness of gold is greatly dependent upon the amount of alloy. Pure gold is too soft to stand the wear; 18 karat is still very soft and is now used very little in the manufacture of jewelry excepting for plain rings and watch cases; 14 karat has been proved to be the best, the hardest and most durable of all alloys and is being almost universally used.

Filled goods were made in Providence very early in the history of the industry there. The pattern or face of the article was stamped out from very thin ribbons of gold of about 18 karat fineness, forming a shell which was filled with solder or pewter and a back of very inferior gold was soldered on completing the article. The thin shell under well cut dies was susceptible of very tasteful shaping and the fineness of the gold gave it a very beautiful surface so that filled jewelry found a ready sale. This method has, however, been almost entirely superseded by a process called roll plating. In this process an ingot of an alloy of copper and brass is made about 20" long, 3 wide and 1/2" thick. It is carefully dressed with a file to a perfectly even surface. A plate of gold 1/4th of the thickness of the ingot is laid upon it and brought into close contact with it by binding it with iron wire, a little of the saturated solution of borax being insinuated around the edges. It is then heated to the degree requisite for a complete adhesion of the metals, and so as not to produce an alloy by melting them this is the most important point in the whole process. When thus heated the ingot is rolled out into a sheet of the thinness required. This process is known as the English method as distinguished from the French method which consists in the application of gold or silver leaf to articles of brass, the union of the two metals being effected by heat and burnishing. Another method of gilding a baser metal was by covering the article with an amalgam of gold and mercury and then volatilizing the mercury. The method now used for depositing one metal upon the other, known as electro-plating, was discovered by W. H. Wollaston, a chemist of London, who coated copper with silver by means of the galvanic battery in 1801. This was only an experiment, however, but in 1837, Thomas Spencer, in Liverpool, and Prof. Jacobi, in St. Petersburg, each of them conducted a series of successful experiments; it was first used in this country in 1842.

(To be Continued.)

### The Story of a Watch.

ONE DAY I was passing through the Green Park. Let me recall that eventful day. I have been working hard all day to catch up lost time, am now walking slowly through the park, when a sight meets my eye which makes me forget fatigue and change my stroll into a sharp walk. A crowd. I am soon in it. What is the matter? Indeed! Then I must stop. One does not see a Sultan every day. This is something like. An Oriental potentate, in all his magnificence, is about to enter the palace of the great Queen upon whose dominions the sun never sets. Hark! Music! Here they come! Hurrah! A rush, a squeeze, a man pushes rudely against me; I glance around at him; he is working his way quickly through the crowd, very quickly. A

suspicion flashes upon me. One touch of my hand to my side makes it certainty. My watch is gone! I plunge fiercely after that man. I think of my wife's tears, of my own vexation; I think, with a tender regret, of winding up time; I feel like a father as I think of the times I have corrected my treasure by the church. I picture Blogg's pretended sympathy and secret glee. I imagine him flaunting his gold Geneva in my face, and myself without my good old forty guinea English lever to put him down with; and all because of that black whiskered vagabond now making his escape. These thoughts—the thoughts of a moment—give me the strength and energy of a lion. I dash and push and squeeze through the people, who give me no aid, but curse me volubly as I stamp on their toes and dig my elbows into their ribs. I make a clutch at him. Missed by a hair's breadth. Oh, if that man between us had been thin! Another attempt; I touch his coat. Once more—I have him! Oh, the ecstasy of that moment, mingled with the fear of his having passed the watch to a confederate! Before I can gasp out a word he turns half round, slips it into my hand, and as I place it in my pocket he makes off once more, this time unpursued, for I have regained my treasure and am satisfied. I do not venture to take it out of my pocket, but walk home at once, keeping my hand on the watch all the way. No one shall come near me till I reach home. I feel very hot, but at the same time a hero. Have I not had an adventure, and have I not come through it triumphantly? No tears now from my wife, no sneers from Blogg. How I shall enjoy winding my watch to-night! Its value is enhanced, it has a story! I wish I could go home on horseback or by steam. I am bursting to tell my wife all about it. At last I am home. I am sitting down. I begin my tale. I tell of the crowd, of the thief, of my loss. My wife tries to interrupt me, I won't allow it, I describe the deed, the chase, the capture, the restitution! I pause for my wife's word of admiration and congratulation, which I am sure will now follow. She says quietly: "My dear, you know you left in a hurry this morning. If you look on the mantelpiece you will see your watch, which you left at home." She was right. I have now two watches!—*London Society.*

### Why Business Men Fail.

LET ME give your readers, says a correspondent of the *United States Economist*, the benefit of the replies I have received from leading men of our country to the question, "What in your observation have been the chief causes of the numerous failures in life of business and professional men?"

Governor St. John answers: "Idleness, intemperance."

Alexander H. Stephens answered: "Want of punctuality, honesty, and truth."

Hon. Darwin R. James answers: "Incorrect views of the great end and aim of life. Men are not contented to live plain lives of integrity and uprightness. They want to get ahead too fast, and are led into temptation."

President Bartlett, of Dartmouth College, names as causes of failure: "Lack of principle, of fixed purpose, of perseverance."

President Eliot, of Harvard, replies: "Stupidity, laziness, rashness, and dishonesty."

Dr. H. M. Dexter, of the *Congregationalist*, answers: "1. Want of thoroughness of preparation. 2. Want of fixedness of purpose. 3. Want of faith in the inevitable triumph of right and truth."

Anthony Comstock's answers are: "Unholy living and dishonest practices, lust and intemperance, living beyond one's means."

Mr. H. E. Simmons, of the American Tract Society, replies: "Fast living, mental, spiritual, and bodily; lack of attention to the details of business."

General O. Howard answers in substance: "Breaking the divine laws of the body by vice, those of the mind by overwork and idleness, and those of the heart by making an idol of self."

Professor Homer B. Sprague, of Boston, answers: "1. Ill-health. 2. Mistake in the choice of employment. 3. Lack of persistent and protracted effort. 4. A low ideal, making success to consist in personal aggrandizement, rather than in the training and development of a true and noble character."

Dr. Lyman Abbott answers: "The combined spirit of laziness and self-conceit that makes a man unwilling to do anything unless he can choose just what he will do."

Judge A. W. Tenney, of Brooklyn, replies: "Outside of intemperance, failure to grasp and hold, scattering too much, want of integrity and promptness, unwillingness to achieve success by earning it in the old-fashioned way."

The attorney-general of a neighboring State replies: "Living beyond income, and speculating with borrowed funds; unwillingness to begin at the foot of the ladder and work up. Young men want to be masters at the start, and assume to know before they have learned." And another reason in the same line: "Desiring the success that another has, without being willing to work as that man does. Giving money-making a first place and right-doing a second place."

Judge Tourgee, author of "A Fool's Errand," considers the frequent cause of business collapse to be: "Trying to carry too big a load." As to others, he says: "I don't know about a professional man's failing, if he works, keeps sober, and sleeps at home. Lawyers, ministers, and doctors live on the sins of the people, and, of course, grow fat under reasonable exertion, unless the competition is too great. It requires real genius to fail in either of these walks of life."

Hon. Joseph Medill, ex-mayor of Chicago, answers: "Liquor drinking, gambling, reckless speculation, dishonesty, tricky conduct, cheating, idleness, shirking hard work, frivolous reading, lack of manhood in the battle of life, failure to improve opportunities."

Among the causes of failure given by my correspondents many may be classified under the general fault of wavering, such as "wavering purpose," "non-stick-to-it-iveness," "failure to grasp and hold," "scattering too much," "trying to do too many things, rather than stick to the one thing one knows most about." A young man spends seven years in a grocery store, and when he has just learned the business he concludes to go into dry goods. By failing to choose that first he has thrown away seven years' experience. Probably, after learning the dry goods business, he will conclude to become a watchmaker, and at last becomes a "jack-at-all-trades," good at none. A prominent merchant says: "Nearly all failures in legitimate business come from not serving an apprenticeship to it," that is, from leaving a business one knows for another which he does not understand.

Another cause of failure is the disposition to escape hard work, and get rich in haste—"desiring the success another man has, without being willing to work as that man does, and begin, as he did, at the foot of the ladder." How many who were in haste to get rich, to reap without patient industry in sowing, have learned the truth of the old proverb: "The more haste, the worse speed!"

### Computation of Time and Changes of Style in the Calendar.

*Addressed to Students of History and Genealogy.*

[BY SPENCER BONSALL.]

*Continued from page 205.*

IN THE preparation of this article it was necessary to consult a number of works of reference for the purpose of comparing the statements of the best authorities on the subject. Information of great importance, to the student of history, in fixing and verifying dates, was found scattered in the volumes consulted, and, for convenience of reference, the notes taken are now given in a more condensed form.

The "New Style" or Gregorian calendar was adopted generally in

Roman Catholic countries immediately after its promulgation, A. D. 1582. Most Protestant countries, however, continued for a longer or shorter period to use the "Old Style" or Julian calendar. It is necessary, therefore, in dealing critically with dates after 1582, to ascertain what "Style" was in use at the time and place in question. The following table, compiled principally from "L'Art de vérifier les Dates," by M. de Saint-Allais, Paris, 1818, "The Chronology of History," by Sir Harris Nicolas, K.C.M.G., London, 1852, and "Handy-Book of Rules and Tables for Verifying Dates with the Christian Era," etc., by John J. Bond, Assistant Keeper of the Public Records, London, 1869, will serve to show when the chief States of Europe adopted the "New Style." As Mr. Bond had peculiar facilities for procuring correct information regarding the changes in many of the countries, and as his book is the latest authority to which I have had access, I have, when any doubt existed, preferred his dates to those of others:

|  | Old Style ended on— | New Style began next day— |
|--|---------------------|---------------------------|
| In Spain, <sup>1</sup> Portugal, and the greater part of Italy, the same day as at Rome and Milan.   | Thu. 4 Oct. 1582    | Fri. 15 Oct. 1582         |
| In France <sup>2</sup> and Lorraine. <sup>3</sup>  | Sun. 9 Dec. 1582    | Mon. 20 Dec. 1582         |
| In Germany <sup>4</sup> and Switzerland <sup>5</sup> (by Roman Catholics).   |                     |                           |
| In Savoy. <sup>6</sup>   |                     |                           |
| In the Roman Catholic Netherlands, <sup>7</sup> viz., Brabant, Limbourg, Luxembourg, Gelderland (in part)— <i>Duchies</i> . Flanders, Artois, Hainault, Namur— <i>Countries</i> . Antwerp (called the <i>Marquisate of the Holy Empire</i> ). Malines— <i>Lordship</i> . | Fri. 21 Dec. 1582   | Sat. 1 Jan. 1583          |
| In the Protestant Netherlands, <sup>8</sup> Holland and Zealand, viz., Rotterdam, Amsterdam, Leyden, Delft, Haerlem, and the Hague.  |                     |                           |
| In Prussia <sup>9</sup> (date of introduction not fixed).  | .....               | ..... 1583                |
| In Poland. <sup>10</sup>   | Tue. 21 Dec. 1585   | Wed. 1 Jan. 1586          |
| In Hungary <sup>11</sup> (date of introduction not fixed).   | .....               | ..... 1587                |
| In Strasbourg. <sup>12</sup>   | Sat. 18 Feb. 1682   | Sun. 1 Mar. 1682          |
| In Denmark <sup>13</sup> and Protestant States of Germany. <sup>14</sup>   | Sun. 18 Feb. 1700   | Mon. 1 Mar. 1700          |
| In Overijssel <sup>15</sup> or Overijsel (date not fixed).   | .....               | ..... 1700                |
| In Gelderland <sup>16</sup> or Guelderland.  | Wed. 19 June, 1700  | Thu. 1 July, 1700         |
| In Utrecht. <sup>17</sup>  | Tue. 19 Nov. 1700   | Wed. 1 Dec. 1700          |
| In Friesland <sup>18</sup> or Vriesland.   | Fri. 20 Dec. 1700   | Sat. 1 Jan. 1701          |
| In Groningen <sup>19</sup> and Protestant parts of Switzerland <sup>20</sup>   | Tue. 31 Dec. 1700   | Wed. 12 Jan. 1701         |
| In Tuscany <sup>21</sup> (date of introduction not fixed).   | .....               | ..... 1751                |
| In Great Britain, <sup>22</sup> Ireland, and the Colonies.   | Wed. 2 Sept. 1752   | Thu. 14 Sept. 1752        |
| In Sweden. <sup>23</sup>   | Sun. 28 Feb. 1753   | Mon. 12 Mar. 1753         |

1 Spain, etc. Bull of Pope Gregory XIII., 24th Feb., 1582.  
 2 France. Pursuant to edict of Henry III., dated 3d Nov., 1582.  
 3 Lorraine. Orders of those who had the spiritual authority in the name of the Bishop, Charles de Lorraine, Nov. 24th, 1582. See *L'Art de vérifier les Dates*.  
 4 Germany. 5 Switzerland. 6 Savoy. Authority not given. See *Bond's Handy-Book*.  
 7 Roman Catholic Netherlands. Proclamation of the Court, 22d December, 1582.  
 8 Protestant Netherlands. By edict or *Plakaet* of 10 Dec., 1582 (entered in the *Great Plakaet boek*, I. 395, in the Record Office of the Hague), the introduction of the New Style was fixed for the 15th of December, 1582; but afterwards settled, by a resolution of the States of Holland, to begin on the 1st of January, 1583.  
 The other provinces only adopted the measure about the year 1700.  
 9 Prussia. "State Papers.—Prussian, 1586."  
 10 Poland. "State Papers, Cracow, 3 January, 1586, *Stylo novo*."

YEARS, MONTHS AND WEEKS.

YEAR (Mæso-Gothic, *jer*; Anglo-Saxon, *gear*; Dutch, *jarr*; Friesic, *jer*; German, *jahr*; Danish, *aar*; Swedish, *ar*; Icelandic, *ar*; Sanscrit, *jahran*, a course, or circle, to move in a circle).

Year, in the full extent of the word, is a system, or cycle of several months, usually twelve. Some writers define it as a period or space of time, measured by the revolution of some celestial body in its orbit. Thus the time in which the fixed stars make a revolution is called the great year; and the times in which Jupiter, Saturn, the Sun, Moon, etc. complete their courses, and return to the same point of the zodiac, are respectively called the years of Jupiter and Saturn, and the Solar and Lunar years, etc.\*

It is stated in Hutton's "Philosophical and Mathematical Dictionary" that a year, originally, denoted a revolution, and was not limited to that of the sun. Accordingly, we find by the oldest accounts, that people have, at different times, expressed other revolutions by it, particularly that of the moon; and, consequently, that the years of some accounts are to be reckoned only months, and sometimes periods of two, or three, or four months. This will assist us greatly in understanding the traditions that certain nations give of their own antiquity, and perhaps also of the great age of men. We read expressly in several of the old Greek writers, that the Egyptian year, at one period, was only a month; and we are also told that at other periods it was three months, or four months; and it is probable that the children of Israel followed the Egyptian mode of computing their years. The Egyptians boasted, nearly two thousand years ago, that they had historical records of events, happening forty-eight thousand years before that period. This statement was evidently intended to deceive the Greeks, with the design of making them believe that they, the Egyptians, were the most ancient nation, an ambition which the Chinese attempt, at present, to imitate, striving to impress us with the idea that they are the oldest people on the earth. Both the present and the early imposters have pretended to ancient observations of the heavenly bodies, and recounted eclipses,

11 Hungary. The Diet of Presburg, held in the presence of the Archduke Ernest, 1587.  
 12 Strasbourg. Through the exertions of M. de la Grange, intendant of Alsace, Feb. 5th, 1682. *L'Art de vérifier les Dates*.  
 13 Denmark. "State Papers, Copenhagen, 2d May, 1702, S. N." (*Stylo novo*).  
 14 Protestant States of Germany. On the 15th Nov., 1699, the old Calendar was universally abandoned within the empire; and a new one, framed by a celebrated mathematician named Weigel, was adopted, which differed only from the Gregorian as to the mode of fixing Easter and the Movable Feasts, so that it sometimes happened that the Protestants and Catholics celebrated that feast on a different day.  
 15 Overijssel (date of introduction not fixed). By resolution, dated 4 April, 1700.  
 16 Gelderland. In accordance with a resolution of the States, dated 26 May, 1700. (*Geld. Plakaet boek*, III: 27).  
 17 Utrecht. By the resolution dated 24 July, 1700. (*Utrecht Plakaet boek*, I. 457).  
 18 Friesland. By resolution dated 11 and 12 October, 1700.  
 19 Groningen. In consequence of a resolution of the States General, of 6 February, 1700.  
 20 Protestant parts of Switzerland refused the New Style until 1700, when Weigel's Calendar was received by those of the cantons of Zurich, Berne, Basle, and Schaffhausen, who commenced the year 1701 on the 12th Jan., N. S.  
 21 Tuscany. By the Emperor of Germany, as grand-duke of Tuscany. (*Genleman's Magazine*, vol. xxi. p. 93).  
 22 Great Britain, etc. Pursuant to Statute 24 Geo. II. c. 23, 1751.  
 23 By edict of the King 24th Feb., 1752. *L'Art de vérifier les Dates*.  
 \* Bond states that "The Gregorian or New Style was adopted gradually after 1696. The King of Sweden, fearing that striking off ten days at once might prove prejudicial to commercial transactions, adopted the New Style gradually, by making no Leap year after 1696 until 1744, by which plan 11 days were dropped. The eleven intermediate 'fourth years' having thus only 365 days each, made the year 1744 the same as other countries where the New Style had been adopted." According to this arrangement, New Style would have commenced on Tuesday, 1 March, 1740.  
 \* Ephraim Chambers' Cyclopædia, 1741.

in particular, to vouch for the truth of their statements. Since the time in which the solar year, or period of the earth's revolution round the sun, has been received, we may calculate with certainty; but, in regard to those remote ages, in which we do not precisely know what is meant by the term year, it is impossible to form any satisfactory conjecture of the duration of time, as computed by the ancients in their chronicles.

The Babylonians pretend to an antiquity of the same fabulous kind; they boast of forty-seven thousand years in which they had kept observations; but we may judge of these as of the others. The Egyptians speak of the stars having four times altered their courses in that period which they claim for their history, and that the sun set twice in the east. They were not such perfect astronomers but that, after a roundabout voyage, they might perhaps mistake the east for the west, when they came in again, particularly as the use of the mariner's compass was unknown to them.

The tropical or solar year, properly, and by way of eminence so called, is the space of time in which the sun moves through the twelve signs of the zodiac. This, by observations of the best modern astronomers, contains 365 d. 5 h. 48 m. 46.14912 seconds. The quantity assumed by the authors of the Gregorian calendar was 365 d. 5 h. 49 m., which corresponds exactly with the observations of Bianchini, and de La Hire, in the next century. In the civil, or popular account, the year contains 365 days, with an additional day every four years.

The excess of the solar year over 365 days has been given by different astronomers as follows:—

| Meton and Euctemon | 5th Century | B. C. | 6 h. 18 m. 57     | sec. |  |  |
|--------------------|-------------|-------|-------------------|------|--|--|
| Hipparchus         | - - 2d      | "     | 5 h. 55 m. 12     | "    |  |  |
| Sosigenes          | - - 1st     | "     | 6 h. 0 m. 0       | "    |  |  |
| Albatagnius        | - - 9th     | A. D. | 5 h. 46 m. 24     | "    |  |  |
| Alphonsine Tables  | - 13th      | "     | 5 h. 49 m. 16     | "    |  |  |
| Copernicus         | - - 16th    | "     | 5 h. 49 m. 6      | "    |  |  |
| Tycho Brahe        | - - "       | "     | 5 h. 48 m. 45.5   | "    |  |  |
| Kepler             | - - 17th    | "     | 5 h. 48 m. 57.65  | "    |  |  |
| Halley             | - - "       | "     | 5 h. 48 m. 54.691 | "    |  |  |
| Lalande            | - - 18th    | "     | 5 h. 48 m. 35.5   | "    |  |  |
| Delambre           | - - "       | "     | 5 h. 48 m. 51.6   | "    |  |  |
| Laplace            | - - "       | "     | 5 h. 48 m. 49.7   | "    |  |  |
| Hind, 1850         | - - 19th    | "     | 5 h. 48 m. 46.2   | "    |  |  |

MONTH (Gothic, *menath*; Anglo-Saxon, *monath*, from *mona*, the moon; German, *monat*; Dutch, *maand*; Danish, *maaned*; Swedish, *manad*).

The next convenient division of time, which is marked out by the revolutions of the heavenly bodies, is the month. The *astronomical* month is the period of time in which the moon performs a complete revolution round the heavens, and is either *periodical* or *synodical*. The *periodical* month is the time in which the moon moves from one point of the heavens to the same point again, and is equal to 27 d. 7 h. 43 m. 47 seconds; and the *synodical* month, or *lunation* as it is sometimes called, is that portion of time which elapses between two successive new moons, or between two successive conjunctions of the moon with the sun, and is equal to 29 d. 12 h. 44 m. 3.19 seconds. The *solar* month is that portion of time in which the sun moves through one entire sign of the zodiac, the mean quantity of which is 30 d. 10 h. 29 m. 3.84576 seconds, being the twelfth part of the solar year.

WEEK (Anglo-Saxon, *weoc*; Dutch, *week*; German, *woche*; Danish, *uge*; Swedish, *veck*).

The subdivision of the month into weeks is very ancient, and has been adopted by almost all nations, excepting the ancient Greeks, the inhabitants of the north of China, the Persians, and the Mexicans. It originated with the ancient Chaldeans, who gave the name of one of the seven planets to each hour of the day, and designated each day by the name of that planet which corresponded with the first hour of the day. In order to understand this, the order of the planets must be given upon the Ptolemaic system, that is, in the order of their distances from the earth, beginning with the most distant: Saturn, Jupiter, Mars, the Sun, Venus, Mercury, and the Moon.

Commencing with Saturn, on the first hour of the first day, and allotting to each hour a planet, in the order named, the first hour of the second day, it is found, would fall to the Sun; of the third day, to the Moon; of the fourth, to Mars; of the fifth, to Mercury; of the sixth, to Jupiter; and of the seventh, to Venus.†

The Latins adopted these designations in their names of the days of the week. They are to be found in old law books and MSS., and are still used by the learned professions throughout Europe.

Occasionally, the *signs only* of the planets were used, for the sake of brevity, particularly in diaries and journals. This is notably the case in the original MS. field-book of Mason and Dixon's survey of the boundary line between Pennsylvania and Maryland, 1763 to 1768, in possession of the Historical Society of Pennsylvania. In this book the name of each day of the week is represented by the sign, in addition to the usual dates, for a period of over four years. See, also, "Minutes of the Provincial Council of Pennsylvania," (Colonial Records) vol. ii., pages 90 to 96, etc., etc. In the latter part of vol. i., (same Records) the Latin names of the days were used.

Our Saxon ancestors, before their conversion to Christianity, named the seven days of the week from the sun and moon, and some of their deified heroes, to whom they were peculiarly consecrated, and representing the ancient gods and planets; which names we have received, and still retain.

| Latin.        | English.  | Anglo-Saxon. | Presided over by |
|---------------|-----------|--------------|------------------|
| Dies Saturni  | Saturday  | Sætern-dæg   | Saturn           |
| Dies Solis    | Sunday    | Sunnan-dæg   | The Sun          |
| Dies Lunæ     | Monday    | Monan-dæg    | The Moon         |
| Dies Martis   | Tuesday   | Tiwes-dæg    | Mars             |
| Dies Mercurii | Wednesday | Wodnes-dæg   | Mercury          |
| Dies Jovis    | Thursday  | Thors-dæg    | Jupiter          |
| Dies Veneris  | Friday    | Frigas-dæg   | Venus            |

In some ancient documents we find the equivalent terms, *Dies Sabbati* for Saturday, and *Dies Dominica* for Sunday. Tiw, Tyw, Tuisto or Tuesco, the Saxon Mars, or God of War. Woden or Odin, a Scandinavian chief or deity, the reputed author of magic, and the inventor of all the arts, and was thought to answer to the Mercury of the Greeks and Romans. Thor was the god of thunder, as well as the ancient Jove. Friga, Freya, or Freja was the Scandinavian Venus; she was the wife of Thor, and goddess of peace, fertility and riches.

This order of the days, first adopted by the Chaldeans, was preserved by the Mosaic law. The Christians, however, began their week on Sunday, and the Mahometans on Friday.

(To be Continued.)

### Transferring Paintings.

TO TRANSFER a painting from one canvas to another is not difficult. First paste several thicknesses of tissue paper on the face of the painting, after taking it from the frame. When it is dry the canvas is wet thoroughly, peel it from the back of the picture, leaving the painting fast to the tissue paper. After it dries again glue a new canvas to the back of the picture, and when it has dried for the fourth time I wet the tissue paper and peel it off. The picture is then ready for the usual cleansing and renovating processes. There are or were very many important paintings on wood, before they were transferred to canvas. When the wood is so old that the paint begins to flake off, from old age, then the only chance to save it from ruin is to transfer it to canvas. For this purpose paste the tissue paper on the face of the painting, and then turn it over and plane off the wood with a plane whose iron has a convex edge. When the wood is worked down thin use a chisel with a rounded edge, and when the white paint, which is usually the ground work of a picture, begins to appear I take off the last of the wood with pumice stone and a damp sponge.

† Edinburgh Encyclopædia.



## Views of Correspondents.

This department of THE CIRCULAR is open for communications relating to the jewelry trade, but the editor does not hold himself responsible for the sentiments expressed by contributors. We invite correspondence, but require that it shall be free from all personalities, and the writer's integrity guaranteed by the disclosure of his true name to the editor. Anonymous communications will not be noticed.

## WATCH CASES OF DEBASED QUALITY.

To the Editor of the Jewelers' Circular:

You have had much to say in your paper about jewelry of a degraded quality, but I don't see any condemnation in your columns of the swindle in watch cases. I have been buying cases of jobbing houses for years, and find it almost impossible to get a case that is actually what it is represented to be. Cases that come stamped 14-k. will not assay more than 10-k. or 12-k., while a large portion of the weight is made up of base metal. If you analyze a 50 pennyweight case you will find about 35 pennyweights of gold and 15 pennyweights of spring and base metal of which the shank is composed. If to this you add the swindle in the quality of the gold—12-k. cases sold for 14-k.—the steal becomes one of magnitude. I am informed, and my experience confirms the truth, of the statement that certain jobbers will contract with case makers for a lot of cases of 12-k. gold, but stipulate that they shall be stamped 14-k. The jobber pays for the making and then charges the dealer for 14-k. cases, including 12 or 15 pennyweights of base metal for which we pay as 14-k. gold. This more than pays him for the cost of manufacturing the cases. The only honest way to sell cases is to charge for the actual weight of the gold contained in them and the regular market price for making them. This steal in watch cases is one of the most outrageous we have to contend with, and we are entirely without redress. If you would devote some of your space to exposing this fraud you would be doing good service.

There is a lesser abuse in the sale of silver cases that ought also to be remedied. The price for silver cases is uniform, and it makes no difference in the price whether the case is a plain one or elaborately engraved. Now, the cost of engraving is something—say fifty cents or more a case—and the dealers who sell them ought to have the benefit of this difference. If I can sell more plain cases than engraved ones, why should I not have the extra profit that attaches to them? Or why should I be charged as much for a plain case as for one that costs more to make? The price of silver cases should be regulated by the plain ones, and any ornamentation charged for according to the labor put on it. Let us get down to first principles in this thing and buy and sell our goods for their actual value, and not palm off steel springs and white metal as gold and silver. If the jobbers referred to will deal honestly by us, and not swindle us both in weight and quality of cases, we can deal with the public with more assurance, and be able to guarantee our goods both as to quality and weight. Suppose you agitate this question freely in THE CIRCULAR and see if you cannot bring about a reform. You find a good many wind mills to fight, like Don Quixote, but here is something tangible for you to take hold of and something that will be of great benefit to all retail dealers.

## FAIR PLAY.

[If "Fair Play" will refer to his file of THE CIRCULAR he will observe that we have had considerable to say on this subject from time to time. He will also see that some months ago some of the case makers adopted a scale of prices based on the actual weight of gold in a case and the cost of making added. If he wants cases made on honor, he should address some of the manufacturers of established reputation and known integrity. There are, fortunately, still some whose stamp affixed to cases is as good a certificate of quality as the stamp of a government mint. The trouble is he has not applied to the right shop.—ED.]

To the Editor of the Jewelers' Circular:

DEAR SIR—We notice in your August number remarks by Mr. Electrode before the Horological Club, and have come to the con-

clusion that if Mr. E. had investigated the subject of magnetism a little more thoroughly he would be a little less positive in some of his assertions. It is a subject which but few understand or know anything about. We do know that we get certain results from certain given conditions.

Mr. E. admits that the watch is protected by our "shield," but his theory of "why and how" it is done is not quite correct. Magnetism is a condition caused by electricity and this magnetic condition induces certain electric currents; and it is the part of our invention to protect the watch movement against all these forces and conditions which is accomplished practically if not absolutely.

With all due deference to Mr. E.'s superior knowledge of all matters pertaining to a watch, we must say that when he speaks of some of the component parts of our invention as being superfluous he is invading grounds which he has not explored, and therefore "knows not whereof he speaks."

We will soon furnish Mr. E. with a full description of our theory proven by experiments and tests to be facts.

We appreciate Mr. E.'s desire to protect the "craft" from errors, and meanwhile are willing to "shake" across the bloody chasm and join forces in all good works for the benefit of the trade..

Yours truly,

GILES, BRO. & CO.

Chicago, Aug. 8, 1884.

## Albrecht Durer.

IN A FORMER volume of THE JEWELERS' CIRCULAR we spoke of Benvenuto Cellini and his works, saying that although born in Italy, he belonged to that class of illustrious men who pertain to no clime or country but are citizens of the world and born to be its teachers, and these remarks apply with equal force to Albrecht Dürer.

From the fourteenth century forward, the citizens of Europe began to disenthral themselves from the galling bondage of robber chiefs and barons. The free Hanseatic towns had entered into an alliance of defense and offense and hunted the latter in their castles; commerce began to revive and brought wealth, which, in turn, fostered trades and industries. In Germany as well as in Italy, Netherlands, Spain and France, the culture of the mediæval age was in full blossom at the close of the fourteenth century, and although the first-named country could not by far offer the inducements held out by the Pope, princes and nobles of Italy who had become rich in trading with the Orient, still it could pride itself on possessing many a skillful master of his art or trade, and the love of the beautiful rapidly permeated all grades of its society. Genius vied with each other in the production of artistic work. The humble citizen sought to acquire and possess the best handiwork of the artisan. The house became the castle, the holiest of the holy, of the burgher; he built it of oak and brick or stone that it should be strong to defy and successfully resist the assaults of man or time, and adorned it with quaint freizes, and mantelpieces, and chimneys, and door carvings that are even to-day the marvel of our highly cultured generation. Although the trade guilds had in former ages been conceived and organized in a narrow spirit, still they sought to inculcate laudable principles; resistance to tyrannical encroachments, the dissemination of trade knowledge and the preservation of an untarnished honor were their main objects.

This was especially true of the gold and silversmiths of that age. Their shops had from the thirteenth century forward been the resort of talented men. The former had steadily grown in importance and formed into rich and powerful guilds, and prelates, princes and nobles deemed it a mark of high honor to be admitted into them.

One of the most powerful as well as celebrated of the goldsmiths' guilds was that of the city of Nuremberg, Bavaria. This city had been the chief organizer and promoter of the Hanse, and grown rich

with the fruits of the great internal trade which it maintained between the traders of the east and the other European marts of commerce, and it ranked as the first city of Germany at the time when Albrecht Dürer was born within its walls—May 20, 1471, according to an entry in his father's diary, "on the day of St. Prudentius, on a Friday of the holy week."

Dürer was both the son and grandson of a goldsmith. His father had emigrated from Hungary and settled in Nuremberg in 1455, where he was esteemed to be one of the best workmen of the city. He married a goldsmith's daughter who bore him eighteen children, three of whom survived. Albrecht was the youngest.

According to his diary both his father and his mother were pious people; of his father he says in an entry: "His daily speech to us was that we should abound in love to God and act faithfully toward our neighbor;" and the entry about his mother shows Albrecht to have been a loving and dutiful son; he says: "My dear pious mother has born and raised eighteen children, has often had the pest and various other grave and painful sicknesses, has suffered great poverty, contumely, insult, frights and contentions; but she has never been vindictive; and she always punished me well when I had been derelict in duty, etc." His father, who perceived the natural talent of Albrecht, educated him carefully, taught him the rudiments of goldsmithing, and at fifteen the latter executed an excellent piece of work in chased silver representing the "Seven Falls of Christ"—in reference to the tradition that Christ fell seven times while bearing his cross to Mt. Calvary. Even as a child drawing was his delight, and he was wont to astonish by the exactness with which he drew parts of the human body and even whole figures, also lines and circles at the first stroke without ruler or compass. His father, therefore, bound him apprentice in 1486 to Michael Wohlgenuth, the chief Nuremberg artist, with whom Dürer served three years. From 1490 to 1494 he traveled in Germany and the Venetian states, and on his return his father "bargained" with Hans Frei, a skillful mechanic of Nuremberg, to give him to wife his daughter Agnes together with 200 gulden, who, although a beautiful woman, proved to be a perfect "she-devil." She embittered his whole course of life, and, as his life-long friend Pirkheimer asserts, hastened his death. The former powerful and jovial man, creditable witnesses say, was starved, oppressed, tyrannized, and his wife finally would no longer permit him any recreation. Prompted by the lowest avarice the quarrelsome wife refused him every expenditure of his earnings. Time has preserved her memory and will keep it alive to be handed down to posterity in company with her worthy sister Xantippe.

After receiving his diploma with all the honors and rights of a master, obtained for his famous drawing of Orpheus, he went to Venice in 1505, where he painted a picture of the martyrdom of St. Bartholomew and one of Adam and Eve, afterward bought for the gallery at Prague. He also visited Bologna where it is said he met with Raphael who esteemed him highly, and that each painted for the other his portrait. After this journey his fame spread widely, and the Emperor Maximilian appointed him court painter with an annuity of 100 florins; and Charles V. confirmed the same in a document still to be seen in the Nuremberg archives. In 1520 he visited the Netherlands with his wife and their maid servant, and they were splendidly entertained at Antwerp and Brugis by the painters, a costly dinner being served on vessels of silver, the whole party conducting them home late in the night by the light of many torches. His expenses were often defrayed at the inns, and he was escorted free from city to city. He says in his journal: "The people did obeisance unto me as if they were leading some great lord." At Antwerp he records: "I was now overcome by a strange sickness of which I never yet heard from any man." This was in 1521, and the "strange sickness"—no other than consumption—took yet seven years to consume his strong frame; he died in his native city April 6, 1528, in his 57th year.

Albrecht Dürer was a painter from love of the art. He was, so to say, a poet-painter, and, beside Hans Holbein, was the first and most genial painter of Germany—he was its Raphael. While this genius was in Italy overwhelmed with honors and wealth, Dürer enjoyed but little of this world's goods, and due to his unremitting diligence only was he enabled to bequeath at the time of his death a sum of 6,000 florins. The following anecdote illustrates the price he received for his pictures.

He painted an altar picture for a merchant, and was forced to ask 200 florins for it in place of the stipulated 130, because "he had been compelled to buy far more than 20 ducats' worth (1 ducat=9s. 4d. English) of the best ultramarine," beside this he had spent two years in place of thirteen months in painting it. He also asked (according to the custom of the time) a dress for his wife and two florins as gratification for his brother. But he informed the merchant in 1509, "Nobody shall any more prevail on me to limn a canvas with so much work. Another such a picture would reduce me to beggary. Of ordinary pictures I will paint so many in one year that no one shall believe that one man could have done it; but this kind of limning will not progress, and I will therefore stick to my engraving; if I had done so I would be one thousand florins better off."

All his works in painting, engraving, goldsmithing, etc., are preserved in European art galleries; very renowned pieces of his work are the rings he made for his intimate friend Martin Luther and Catharine v. Boren, with the description of which we will close our hasty sketch of this remarkable man.

One of these rings is a double hoop surmounted by a high conical box containing a ruby, the emblem of devoted love, and a hard, glittering diamond, the emblem of manly strength and faith. In the interior of the hoops are engraved the initials of the names of the affianced, C. v. B. and M. L. D. (Doctor), also the Biblical verse, "What God hath joined, let no man put asunder."

The other ring is far more artistic, and for so small an article a masterpiece of engraving. It consists of a broad main hoop of skeleton and raised work set with a glittering ruby, and of two side hoops richly ornamented with figures. These three hoops are firmly fixed together. The one-half of the main hoop represents a tree with branches which is transformed by a cross-bar underneath the ruby into a cross, upon which is seen in half curvature the form of the Crucified exquisitely worked even to the contortions of the muscles. At the foot of the tree, immediately beneath the feet of Christ, are the dice of the soldiers and the three nails. The other side of the main hoop carries the inscription of the cross, I. N. R. I., and a pillar bound round with ropes to recall the scourging of the Saviour. Upon the side hoops are the instruments of torture, spear, rod with sponge, scourge and the ladder leading up to the cross, sword and knife and the head of a soldier. In the interior of the ring are the full names, D. Martinus Lutherus, Catharina v. Boren, 13 Juni, 1525.

These masterpieces, priceless in several respects, of Dürer's art of goldsmithing, have long been separated and passed into foreign possession. In 1703, King August of Poland presented one of them to the Duke of Brunswick who bequeathed it together with Luther's ring of the dignity of Doctor to the University of Helmstädt. The other was offered for sale through a newspaper for 1,000 ducats, and was in the beginning of this century presented to the daughter of a wealthy family in Leipzig by her father-in-law. It is highly probable that it has remained in her or her heir's possession ever since.

It is not the task of THE JEWELERS' CIRCULAR to dwell at length upon and criticise his works. It is left to the intelligence of its readers; its province is simply to portray the lives and works of the great masters of the art for the admiration of succeeding generations of workmen, that they may every day more fully appreciate the depth of immortal Webster's remarks to a young law student who complained of the superabundance of lawyers: "There is always room higher up, young man."

## The Order to be Observed in Repairing Watches.

RICHARD TRUMPY, in a communication to the *Allg. Journal d. Uhrmacherkunst*, says "that time is money," and that this motto of our trans-atlantic brethren should be better heeded by our workmen who are engaged in the repairing of watches than they do at present.

After a long introduction and elucidation of the method he proposes for adjusting, repairing or cleaning a watch, he says that it need not be expected that he intends to publish a secret by which a watch can be made perfect in the twinkling of an eye, but that the entire secret consists simply in avoiding all superfluous handlings of the single parts of a watch for the purpose of observing its action. Let us suppose that our task is to adjust or repair an ordinary cylinder watch, and we would do as follows:

We take the watch in hand and open the hind cover. A glance is enough to tell us whether the winding square projects beyond the dust cap. Should this be the case, take a sharp shoulder file and file down the square until it is a trifle lower than the dust cap. The danger of breaking off the square need be anticipated only in the hands of a very unskillful person or by the use of a dull file. When this has been corrected, seize the setting square with a pair of tweezers and move it up and down, paying strict attention to the quantity of shake. Open the crystal and repeat the process. If there is too much shake now then the center staff touches the glass. If the proportions admit of it, after having removed the minute hand, file the center staff shorter (exactly in the same manner as was done formerly with the winding square).

Next see whether the moving parts in the case are entirely free, and that the dust cap joint do not press upon or displace the fourth wheel bridge. Next take down the dial, inspect the minute work depthing, see that the barrel cannot touch the latter; that the stop work, as well as the barrel square upon which the male stop sits, do not touch the dial and that no screw projects beyond the plate, or that the minute wheel pin do not stand above the latter. Take the movement out of the case. Observe the position of the barrel to the center wheel and take down the former. Then examine the escapement, closely inspect it for the purpose of finding defects, also observe the position of the balance spring, inspect the kind of motion of the regulator, and finally loosen the screw of the lower cap jewel to see whether the lower cylinder pivot sufficiently protrudes through the jewel hole.

Take down the cylinder, correct all the defects found in the escapement, lay the balance spring and again examine the vibrations of the escapement. Then take down the center and third wheels and investigate the depthing of the fourth wheel and scape pinion. When satisfied of its good condition, polish all the damaged and faulty pivots. Then, if it should be necessary, correct aforesaid depthing, after which mount the center wheel; see that it stand straight and next regulate the depthing of the center wheel and third pinion as well as that of the third wheel and fourth pinion. Then improve discovered defects of the barrel and finally observe its depthing with the center pinion.

Proceed to harden every soft screw, shorten those that are too long, round them, polish the setting square in case it should need it. The screws are best tempered in oil, and that which still adheres to them after they have been withdrawn is to be set ablaze until burned off. This gives them the right temper, and the grinding, for the purpose of annealing, is dispensed with. Then clean the watch. This is done by first placing the plate into the benzine jar, next the bridges, on top the wheels, escapement and other small parts. When withdrawn clean first the escapement, then the wheels and finally the plate.

When mounting, first return the fourth wheel, then the scape wheel, and after this the third and center wheels. Mount the center staff together with canon pinion, and examine whether the running work move free in all positions. Mount the cylinder and

finally the barrel. Repairs necessary to the case must be attended to before cleaning, after the parts have been placed in the benzine.

An adjustment or a repair performed according to this method can be made in about 6 hours by an average workman, and at the same time he can make corrections which might actually be considered superfluous, for instance, the grinding of the lower face of the bridge, etc.

## Problems in the Detached Lever Escapement.

BY DETENT.

WE WILL now pass to the consideration of the club tooth lever escapement: this form of escapement is now almost universally used, and will, therefore, require our most careful attention. In changing our model for this escapement we will only have to make a new scape wheel and pallets to study the action; the fork and roller action needing no alteration. As probably my readers are well aware the club tooth escapement is principally different from the ratchet tooth in having the action divided between the pallet and the tooth, both having inclined impulse faces. The club tooth having also an advantage in closer escaping as the back of the tooth being undercut thereby allowing the pallet to pass inward at the back of the tooth, giving from one-half to a full degree more impulse arc in the scape wheel action although no more in the pallet action. The action of this style of escapement is a little more complex and difficult to understand than the ratchet tooth, but is quite as easy to repair if once the principles are understood. The American and Swiss watches have almost universally this form of escapement, consequently four-fifths of the watches one has to repair is either of one or the other of these makes; it therefore behooves us to master the principles involved and fit ourselves with the best appliances for its correction and repair. The most American watch being provided with exposed pallets set in slots can be moved and manipulated until a near approximation of the correct action is obtained. This ease of change and adjustment being very nice for those who thoroughly understand the principles involved, is very vexatious to those who are so unfortunate as to lack this knowledge. After a brief investigation of the usual accidents to which the American form of this escapement is subject we will take up the Swiss and give the correct method of drawing and making this escapement. The reasons for proceeding in this way is the American scape wheels of all the factories are nearly duplicates of each other as also the pallet stones, consequently there are but few changes which need to be made except in setting the pallet stones. We will first give the method of setting the American pallets and then speak of the changes we are called upon to make with the Swiss. The American watches made by the several factories have different methods of arriving at similar results. One factory acting from their convictions assume they can overcome slight inaccuracies by one method, while another insists their system is the best. The writer does not propose to discuss this matter as it might be construed into a puff for one factory to the disparagement of another. The most frequent disarrangements to which the American lever is subject is the breaking or loss of the jewel pin, and the loosening and loss of a pallet stone. In putting in a jewel pin one should always remove the lever from the movement so as to get at the exact size of the fork, selecting a jewel pin which has only sufficient side shake to be safe. To set a jewel pin remove the hair spring and fill the hole where the jewel pin goes with cement drawn out into filaments about the size of a large bristle. Some little skill is required to do this expeditiously. The cement is made by mixing a little gum myrrh with the best gum shellac, and melting both together at the lowest temperature in which they will thoroughly unite. While the mass is warm it is drawn out into threads of near the size of the hole in the roller. Take the balance (with the hair spring removed) in a pair of tweezers and move it back and forth through the blaze of your alcohol lamp until hot

enough to melt the cement when you touch the jewel hole with one of the filaments and it will instantly be filled with cement; or a small piece of one of the cement threads can be broken off and inserted in the hole and melted. At any rate no great surplus of cement should be used as it not only makes a smeary unworkmanlike job but is liable to get into the passing hollow and interfere with the guard pin.

After the hole is filled, and while the roller is hot, insert the jewel pin with an extra pair of tweezers, being sure to keep the flat side of the jewel pin to the front and keeping the jewel pin upright. I do not suppose it is necessary to say do not heat your balance so as to change its color or burn the cement. In setting pallet stones the same kind of cement is used. Some persons use shellac dissolved in alcohol; this is not desirable, as it leaves the cement or shellac porous from the bubbles the alcohol forms when being driven off by heat. In order to get at the proper angle and position of a pallet stone, the fork should be put in the watch and the banking screws turned so the guard pin will just touch the roller; the balance should now be put in without the hair spring and revolved to see if it enters the fork properly, bending the guard pin if necessary until this result is obtained. With the fork and roller action in this condition the tooth should just reach the locking face of the pallet engaged. If now we remove the pallets and insert our pallet stone to be set, placing it as near in the correct position as we can judge trying it with the scape wheel to see if it is too close outside or inside. Next place it in the watch and see if a tooth resting against it (the new jewel) just rests on the locking face, see fig. 1. Now

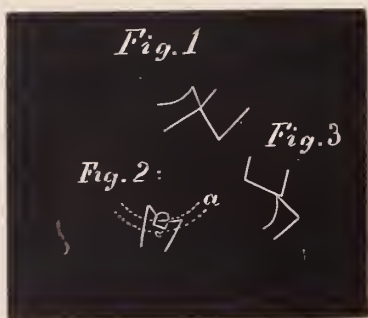

open the bankings until the tooth will escape, and it should be all right if the directions have been complied with. If, on the other hand, the pallet is in too far, the pallets should be removed and heated and the stone pushed back trying it again with the scape wheel to see if the teeth pass readily between the pallets inside and outside. To make the instructions still more explicit we will recapitulate. If the guard pin rests against the roller and the other parts of the escapement are all right, the following conditions will exist:

The jewel pin will enter the fork freely, see fig. 2, and the fork will pass over against the opposite banking pin where it will rest, but as both banking pins are too close the tooth which just touched on the locking face can not escape (see fig. 3), as both bankings are too close if they hold the guard pin against the roller. But remember the guard pin is in just the right place when if pressed against the roller it will barely permit the jewel pin to enter the fork (see dotted line *x*), and the pallet is in just the right position (as far as lock is concerned) if the guard pin is resting against the roller and the tooth engaging the pallet is as near leaving the locking face of the pallet as it can and not do so. But if on opening the bankings so as to remove the guard pin free of the roller the pallets will escape, and only a good, fine secure lock is obtained, we may feel sure that the pallet stone is properly set. The Swis club tooth escapement is not so easily managed as they are frequently, especially in the cheaper grades of movements, faulty, both in the pallets and in the teeth. In our next communication we will give the method of drawing a correct club tooth escapement and also point the best means of correcting the several faults.

## Gossip From Providence.

[From Our Own Correspondent.]

THE business outlook is far from satisfactory and the general opinion seems to be that there will be only a moderate fall trade. If anyone doubts the utility of advertising I should like to give them a practical illustration by taking them through the various jewelry factories here, for the only houses who are really busy just now are noted for their enterprise in this way, and include such firms as Howard & Son, Foster & Bailey, C. F. Irons and F. I. Marcy & Co. There is considerable feeling here on the subject of consigning goods. I understand that several of the New York wholesale houses are trying to make arrangements to get their goods in this way, and as might be expected the manufacturers do not favor such a plan. They argue that jewelry, especially plated jewelry differs from most other manufactured goods. Styles vary every season, and goods made in the spring are old-fashioned and unsalable at the end of the year. Again jewelry readily tarnishes, and all that is returned has to be cleaned and polished up at considerable trouble and expense. A manufacturer told me his experience in this respect the other day. In January and February, '83, he consigned to a large New York house a nice salable line of goods to the amount of \$4,000. In July of same year he let them have \$2,500 more, and in January, '84, they squared up their accounts, when he found they had sold \$1,780 and the balance was returned to him, and on this he says he could not realize more than 75 per cent. of cost of manufacture. He earnestly assured me that this was first and last deal in this way, and judging from the strong language he used I am inclined to believe the latter part of his assertion. On sound business principles I think the policy of consigning goods is indefensible and no fair thinking wholesaler can assert to the contrary, but like many other impositions the remedy lies in the hands of the manufacturers themselves.

Another bone of contention between manufacturers and their customers is the dating of bills ahead. It is quite a common thing for buyers when ordering goods, say in July and August, to stipulate that the bills shall be dated 1st October, and I have even heard of instances where the 1st of December has been insisted on. The object of this is, of course, to get two or three months extra credit and then claim the cash discount. But let us take cases where bills are not nominally paid in 30 days (and they are in the proportion of 6 to 1 of those that are), and see how the matter affects the manufacturer. A bill dated 1st October and sold on 4 months time falls due 1st February, and on or about that time the vendor generally gets a note at 4 months which will bring the time up to nearly 12 months before he gets his money, and he is lucky if he gets it all then. Now, under such conditions I put it to any reasonable person if it is to be wondered at that the manufacturers sore, and in some instances are inclined to sell direct to the retail trade. The jobbers in their own interests want to be careful how they force such issues on manufacturers, for they must bear in mind that the profits of the latter class are now cut down to a minimum.

The reception tendered to Mr. Jno. McCloy and his bride by the members of the N. E. M. J. A. came off at their rooms on the 19th ulto. with great *eclat*. There was a large gathering. The orchestra of the association played with good taste some very enjoyable selections, appropriately commencing with Mendelssohn's Wedding March. The President made an appropriate address, to which Mr. McCloy responded. During the evening refreshments were served, and the meeting did not break up till a late hour. The monthly meeting of the Association was announced for the 1st inst., but there not being sufficient members present to form a quorum, no business was transacted.

Mr. Bailey, of Foster & Bailey, has just returned from a tour in Europe and looks all the better for his vacation. Mr. S. C. Howard (Howard & Son), returned from a similar trip yesterday and is also improved in appearance. Amongst the western buyers who recently visited this market I noticed Messrs. Knights, Wallis and Liberman,

of Chicago, Mr. Newman, San Francisco, Mr. Baldwin, St. Jo, Mo., and Mr. Dahlheimer, Cincinnati.

Stone & Griffith, manufacturing jewelers, have dissolved, and A. C. Stone continues the business alone.

By the way, Mr. Editor, do you know what one hundredth plate is? I take it you do not, so I'll just give you the definition I got from a plater from whom I made an inquiry on the subject. He said: "Get an ounce of gold, dissolve it in about 40 gallons of liquid, get the whole boiling and hold the brass you want plated over the evaporating steam for about 30 seconds and that's one hundredth plate." Well, sir, the other day I happened to call on one of the manufacturers who use this quality of plate and he was loud in his denunciation of a rival house. "Do you know the Alaska Mfg. Co." said he. I replied in the affirmative. "Well," said he, "you should see what wretched stuff they make up; it won't stand acid. Why I designed a cat lace pin and they have stolen my design, and cut prices on me and make money just because they use such poor stuff. See here, this is my cat, that is theirs. Now, just try the acid on theirs." I did so and sure enough it boiled up nice and green. "There," said he, with the air of a martyr; "what did I tell you—just excuse me for a moment, I have to go into the shop." During his absence I tried the acid on his cat, and to my surprise it boiled up worse than the other. On his return I said: "Why, Mr. B., the acid turns your pin also," at the same time pointing out the spot. "Want to know," said he very slowly. "Why, it's them durned boys as will polish the stuff too hard, and its no use talking to them." ASMODEUS.

Providence, R. I., August 13th, 1884.

## Sight.

### WHAT THE OPTICIAN SHOULD KNOW ABOUT OPTICS.

Based upon an extensive hospital experience in Austria, Germany, England and New York. By C. A. BUCKLIN, M. D., New York. Author of Detection and Correction of Visual Imperfections, Cause and Cure of Cross Eyes, Effects of Color on Distance, and Monograph on Astigmatism.

*Continued from page 216.*

If our readers will carefully read and consider the following letter of enquiry they will see at once that the writer asks questions that every dealer in optical goods has at some time suggested to himself.

July 22d, 1884.

*To the Editor of the Jewelers' Circular:*

DEAR SIR—Will Dr. Bucklin inform me on the following points: I have Snellen's test type for testing the acuteness vision for distance and for near vision. The type for distance is graded as follows: 20, 30, 40, 50, 70, 100, 200. Is there a way when a person examined for myopia of hyperopia (as well as presbyopia) can be fitted the first time *about right* so as not to require the trial of but two or three pair of glasses, thereby saving considerable time to the optician and annoyance to the customer. I see that either by experiment or by some rule that presbyopia is fitted in that way, and would like to know what the rule or method is whereby we can find about the right number of glass either in presbyopia, myopia or hyperopia by referring the customer to Snellen's type for either near or distant vision, and when they declare they can see to a particular line. J. D. H.

In presbyopia, be it simple or combined with hyperopia or myopia, the near point of distinct vision, owing to stiffness of the lens, has been carried too far away to make reading in most cases comfortable and in other cases possible. Therefore, in correcting presbyopia, we have practically only this one difficulty to overcome.

We are obliged to so reduce the requirements of the accommodation by the use of simple convex lenses that, with the amount of accommodation the person still possesses, the reading is brought out clear at a distance sufficiently close to be comfortable.

Thus, for example, a man sixty years old who has not abused his eyes by using glasses which were too strong would probably require convex 16 to read with. Had he, however, previously had a hyper-

opia of  $\frac{1}{30}$ , at the age of sixty he would be wearing at least No. 12. The usual amount of presbyopia at the age of sixty being  $\frac{1}{16}$  and his hyperopia having been  $\frac{1}{30}$ , the lens required will be  $\frac{1}{16} + \frac{1}{30}$  = about No. 12. Had he previously been  $\frac{1}{30}$  near-sighted, which degree frequently exists without the knowledge of the person having it, he would have gone to the age of fifty five at least without any lenses for reading, and at sixty would only have required  $\frac{1}{16} - \frac{1}{30}$  = about convex No. 34.

Thus it will be seen at given ages the number of lenses required for reading vary greatly. Sometimes the lens becomes prematurely stiffened with age, other times the pupils are a little larger; but, whatever the cause may be, if the person be suffering from presbyopia, the lens required to eliminate this element of the case may be determined very closely by placing a card at the distance he should read with the print he desires to read; if he cannot read the print we can by actual experiment so grade the print by having lines of different size that when the finest line is found which he can comfortably read we can judge very closely as to the number required to read the fine print.

By this method we obtain about the lens required, although we never know how great an element hyperopia, myopia or other defects is in the case.

We can never judge from this test the lenses which would be required to make distant vision distinct.

*Snellen's test type* for distance are of no use without the assistance of test lenses for determining the lenses required to correct any visual defect; they are simply a graduated measure to tell how much a person can see either with or without lenses.

In presbyopia you bring the person to the actual test of seeing required objects at a required distance, and simply supply the amount of lens required ignoring all other existing conditions. In myopia and hyperopia requiring glasses for distant vision there are several conditions existing which complicate their correction. Thus if a person has a mild degree of myopia which enables him to see the XXX line of Snellen's test type at twenty feet, another person owing to a slightly larger pupil might not be able to see the L line.

The same would be true of hyperopia, to a less degree, however, than myopia. In hyperopia of an excessive degree the retina is frequently not as perfectly developed as in the normal eye or as in other eyes having the same degree of hyperopia; thus two persons having the same degree of hyperopia would not be able to see equally well owing to this cause.

In myopia the defect is usually developed by a gradual stretching of the eye-ball. Now, if the stretching takes place in the anterior part of the globe those parts of the retina used in seeing are left uninjured, and the acuteness of vision remains undisturbed. Should the eye-ball give, however, in its posterior portions during the stretching process which produces the myopia, those portions of the retina used in seeing frequently become so injured that vision is decidedly reduced from this cause; thus it is seen that from either of two common causes (a larger pupil or a stretched and injured retina), two persons having the same degree of myopia may not have the same acuteness of vision.

It is impossible to obtain the required lenses for these cases in any other way than testing with lenses till the best possible result has been obtained.

I refer you to February number of THE CIRCULAR for the most rapid manner of determining glass required.

July 22d, 1884.

*Secretary of Horological Club:*

Will you please put me on the track of a good book on the eye, and how to fit glasses perfectly. Also how to find the number of a double concave or near-sighted lens. W.

Every book on a technical subject requires much study and long deliberation over each subject. It cannot be read and digested after dinner. You must also put the ideas you obtain into actual practice as this is the only way of becoming sufficiently familiar with

them to have them of any practical use. Everything a man can possibly want can be found in a little book of seventy-five pages, called "Detection and Correction of Visual Imperfections." It is published by The Spencer Optical Mfg. Co., New York, and costs one dollar.

If you have not a focussing box you must take a convex lens of a given number and look through both lenses at a distant object; now shake the lenses slightly; if the observed object moves in the same direction your hand moves, the concave is stronger than the convex lens; you must continue to increase the convex lens till one is found which will cause the observed object to stand still when you observe it through both lenses and shake your hand. The number of this convex lens will also be the number of the concave or near-sighted lens.

If upon shaking both lenses observed objects had moved in an opposite direction from the movement of the hand, the convex lens would have been stronger than the concave and you should have sought a weaker convex lens till one was found that caused objects observed through the combination to remain stationary when the hand was shaken. I have always found that those who, after long experience, could tell the strength of a glass from looking through it very frequently make grave blunders. Professor Stilling, of Castle, Germany, always prided himself on his ability in this direction, but I have frequently seen him make a mistake of four numbers.

The introduction of a most perfect polariscopic pebble tester which can never get out of order or out of adjustment and which only costs one dollar and fifty cents is the latest and most interesting news I have for those readers of THE CIRCULAR interested in optical goods. The instrument is a finely finished nickel plated cylinder  $\frac{3}{4}$

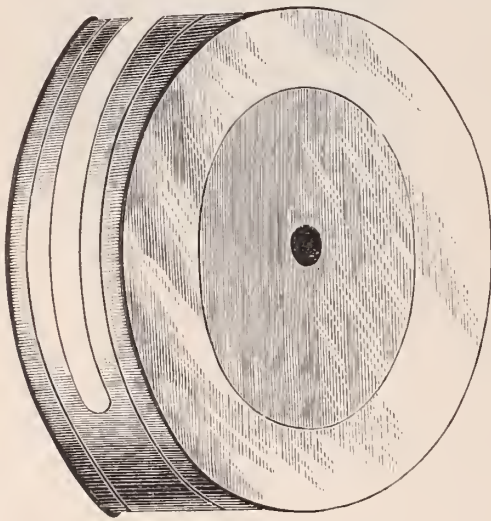

FIG. 1.

inch long and about one and one-fourth inches in diameter. The cylinder has a nicely finished slot in the side which will admit any lens to be examined. The instrument is grasped between the thumb and finger so that the finger always falls on the edge of the lens which is being examined.

This method I have found is the most convenient and removes from the instrument every possibility of its getting out of order. There is no form of spring for holding the lens in place which works so quickly with such perfect satisfaction and with so little danger of scratching the lens should it prove to be soft glass as the finger applied in the manner above described.

At each end of the cylinder there is a finely finished nicked head which fits with the greatest accuracy. Through each head there is an opening  $\frac{1}{8}$  of an inch in diameter; behind each opening within the instrument there is a piece of mineral which has a grain to it. Light coming from an object will pass through one of these pieces of mineral, but in coming through it is so acted upon by this first plate that if another plate is placed behind it with its grain at right angles to the grain of the first plate it is impossible for any light to get through.

The substance of which a pebble is made has a circular polarization; light after coming through the first plate is so twisted by a pebble that some of its rays fall in the plane of polarization of the second plate.

This is never true of any glass lens but is only true of pebble lenses. Consequently if a lens is placed in the instrument and light comes through you are certain that it is a pebble; and if light does not come through you are certain that it is glass.

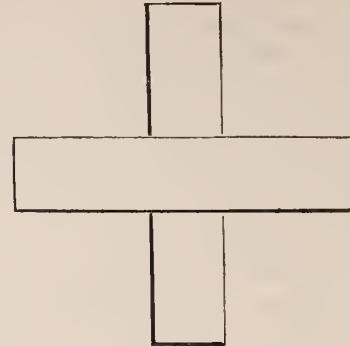

FIG. 2.

The above cut represents the plates of the pebble tester when they are adjusted; should the relative positions of the grain of the two plates be changed the sixty-fourth of an inch the adjustment of a pebble tester is destroyed, and it will allow light to come through whether the lens be *pebble*, *glass*, or there be no lens in the tester.

The instrument is very ornamental, and is so small that it can be readily carried in the vest pocket at all times. The plates in the instrument are of the best material that has ever been used for this purpose.

It has been the desire of the Spencer Optical Manufacturing Co. for some months to place in the hands of the trade a first-class pebble tester, which required no skill to adjust, and which, under no circumstances, could be made to lie. For example, Mr. Brown, who is a strictly honest dealer, makes a price for a pair of pebbles, and shows the person through a properly adjusted pebble tester the difference between a pebble and a glass lens. Mr. C., perhaps, is not a strictly honest dealer; he gives his pebble tester a slight shake which throws it out of adjustment; he puts in a glass lens through which the light will now come the same as it did through the pebble owing to the tester not being adjusted. Having deceived the customer as to the nature of the lens he offers for sale, Mr. C. can naturally make a better price for glass than Mr. B. can for pebble. There are very few honest men who know to what an alarming extent they are injured by this underhand manner of using adjustable pebble testers.

After having invested considerable money in this enterprise it was supposed that the project must be abandoned. Neither the English, German or French market could furnish the mineral in large quantities. No firm could be found who would part with any of it in the rough state. Those who would furnish it would only furnish very limited quantities of finished plates, and for such quality as we desired the best price we could get was seventy cents each or one dollar and forty for the stone plates for each machine.

It appears that in France at the present time they use inferior material, cut it very small and it is so full of fissures that to prevent it from falling to pieces they cement it to a piece of glass. Some of the material used has this peculiar optical property so poorly developed, that in order that the light may appear more perfectly excluded they mount the stones on dark glass.

It was an accident which enabled the Spencer Co. to furnish the trade with a pebble tester at the very cheap price of one dollar and fifty cents, which has stone plates without fissures of sufficient density to be worn as gems, and having this peculiar optical property so highly developed that without any artificial assistance two plates turned at right angles to the direction of their grain entirely exclude the passage of light.

This lot of mineral amounts to some fourteen pounds, is of a bright green color; it was mined in Brazil some seventy-five years ago. It was so perfect that it was supposed to have a gem value. After laying about Paris for many years the owners being unwilling to part with it only at a gem value, it was finally purchased by an American firm and brought to this city for the purpose of cutting gems from it. Had the color been that which was most in demand for gems each crystal would have brought an incredible price. The owner, after having it for many years, was tempted by a cash offer from Spencer & Co. to part with the lot.

I am informed by leading mineralogists that this collection is the only one known of which is so well fitted for the purpose of making polariscopes for testing pebbles. I do not think that any reasonable amount will enable this or any other firm to duplicate this lot of mineral in quality or quantity. It is therefore proposed to manufacture this limited amount of mineral into polariscopic pebble testers without any expectation of being able to continue their manufacture after the supply is exhausted.

There always has been a demand for pebble lenses. Business men are many of them willing to pay a good price for eye-glasses which they can wear on a hook without having the centers of the lenses become opaque from scratching.

There is a large demand for both glass and pebble lenses. I do not believe in encouraging the use of one or discouraging the use of another. Some persons will not scratch a glass lens; others engaged in certain kinds of business will scratch them in one week so they are not fit to use.

---

### An Elegant Catalogue.

ONE OF THE most elegant examples of the typographical art is exhibited in the new catalogue just issued by the Meriden Britannia Company. It is, rather, a supplemental catalogue, inasmuch as it contains only illustrations of their new goods provided for the fall trade of the present year; while for their older standard designs inquirers are referred to their more extended catalogue issued in 1882, which contained illustrations of all the numerous varieties and designs of goods made by the Company up to that time. The present supplemental catalogue is a work of art in itself, reflecting credit equally upon the enterprising company that provided the material, the engravers who made the illustrations and the printers who performed the mechanical part of the work. It comprises ninety pages somewhat larger than those of THE CIRCULAR, of illustrations, printed on heavy cream-tinted paper. The cover is of imitation alligator skin, on which is printed in bright gold letters the name of the company, its address, etc., which is handsomely set off by a gold border top and bottom. The first page of illustrations is a marvel of beauty. It represents a sideboard loaded with beautiful plated ware of new and exquisite designs, the whole being embossed and artistically colored in all the shades found in the various metals employed in the manufacture of the articles or by the artists in decorating them. The top piece, a statuette representing a mounted Indian in the act of killing a buffalo, stands out in bold relief in old silver, while on one side is a figured punch bowl in bright silver; opposite is a fruit dish in silver, gold lined, with applied decorations; in one corner at the base is a lamp in gold, copper and bronze, the glass globe handsomely painted, while on the opposite corner is a hammered silver pitcher with gold ornamentation; the center piece is a plaque with sconces having a frame of different colored gold, surrounding a picture of a bird and fruit; beneath this is a colored glass dish on an elegant silver and gold standard. The embossing process by means of which these various forms are made places them all in relief, while the natural manner in which so great a variety of color is imparted to them is something wonderful. There is also an illuminated page representing several pieces of silverware inlaid with gold and variously colored which is also very beautiful. The

remainder of the catalogue consists of wood cuts printed in black, representing a great variety of new patterns and designs in plated ware. The engraving of the cuts is excellent, all the elaborate details of the design in the original goods being accurately reproduced in the illustrations.

As an indication of the extent to which the art of silver plating has been applied, there are exhibited in this supplemental catalogue seventy-two separate and distinct articles of bric-à-brac, table ware, etc., while the illustrations of the different designs in which these articles are made are innumerable, and this catalogue embraces a small portion only of the wares made by this company. There seems to be no end to the articles that can be made in silver plate, while the means for its elaborate decoration are increasing every day. A glance through this new catalogue is sufficient to make an ordinary man envious, and to drive the average housekeeper out of her senses with a desire to secure the many beautiful and useful articles represented. Included in the work are a few pages of illustrations of Rogers Bros.' table ware, showing a great variety of their new patterns, among which is the Arcadian, that has proved to be so popular. This elaborate and artistic catalogue, a triumph of the printer's art, is a fair example of the enterprise and business tact that characterizes the Meriden Britannia Company. It is designed exclusively for the trade, and can only be obtained by those known to be engaged in the jewelry business.

---

### Proceedings of the Horological Club.

---

#### A DISTINGUISHED BODY OF WATCH AND CLOCK MAKERS.

---

*One hundred and twenty-third discussion.—Communicated by the Secretary.*

---

[NOTICE.—Correspondents should write all letters intended for the Club separate from any other business matters, and headed "Secretary of the Horological Club." Direct the envelope to D. H. Hopkinson, Esq. Write only on one side of the paper, state the points briefly, mail as early as possible, as it must be received here *not later* than the eighth day of the month, in order to be discussed and reported in the CIRCULAR for the next month.

---

#### DEATH OF MR. HOPKINSON.

The Chairman, in opening the meeting, expressed his gratification at the presence of all the members, and said: We are met to pay the last tribute of respect to our departed friend and benefactor, D. H. Hopkinson, whose death occurred since our last meeting.

Mr. Hopkinson was really the founder of the Club, and had never wearied in doing everything to help it along and to promote its efficiency and usefulness. To him is largely due whatever of good we have been able to accomplish during the ten or eleven years of our existence as an organized body, and we may reasonably hope that our influence has been productive of benefit to the trade. It would hardly be fitting to review the many improvements we have brought before the trade, the great amount of valuable information published, and the many good workers whose labors we have commended and encouraged, including Saunier, Grossmann, Smith, Sandoz, Excelsior and numerous others, but we may point with pride to our published Proceedings of one hundred and twenty-two meetings in THE CIRCULAR as evidence of what we have done for the trade—and all of which we offer as a memorial of the liberality and efforts of Mr. Hopkinson.

When the Club was started, THE CIRCULAR was a small 8-page journal, without cover and in newspaper form; but by the skill and good judgment of its conductor it has come to be acknowledged as the leading journal of our trades, both for valuable quality of matter and elegance of arrangement and appearance. We are glad to know that his journalistic enterprise not only gained him great credit here and abroad, but paid him handsomely in a pecuniary way, and we believe that it is the only horological publication that ever became permanently established on a paying basis—another testimonial to

his skill, tact and good judgment, in that he succeeded where others failed. What will be the future of THE CIRCULAR we do not know, but we sincerely hope that it may fall into earnest, competent and skillful hands, and that his successor may achieve as creditable and complete a success as did Mr. Hopkinson, and one which will be as full of advantage and satisfaction to the various crafts for which it is published.

As a business man his reputation was without a flaw. Always prompt, considerate and liberal, he was so good a judge of human nature that he was very rarely mistaken or deceived, and his few financial mishaps were more the result of adverse circumstances which could not have been foreseen than of any lack of judgment or foresight. His ways were gentlemanly and agreeable, and he was always pleasant, genial and friendly. We do not know that he had an enemy in the world, but every one spoke well of him and liked him. This is something that can rarely be said of any man, but we believe that it can be truly said of the late publisher of THE JEWELERS' CIRCULAR. If his successor is as fortunate he will be fortunate indeed.

Mr. Regulator, Mr. Waltham, Mr. Ruby Pin, Mr. Electrode and others added many earnest words of commendation, and related instances of his generosity and devotion to his friends.

The following letter from "Excelsior" was then read:

LETTER FROM EXCELSIOR.

*Secretary of Horological Club:*

I regret my inability to be present at your "memorial meeting," for Mr. Hopkinson was one of my oldest, best and most valued friends. Our confidential relations made me more intimately acquainted than would otherwise have been the case and enabled me to know him thoroughly. With that knowledge, I consider him one of the finest men I ever knew. He was honorable in all his dealings, true to his promises, faithful to his friends, and always ready to render them a service. An instance of this last named trait, and one which has a peculiarly touching interest for me since his death, is the fact that the last article he ever wrote was the editorial on "Excelsior," in the July CIRCULAR.

He was very fond of his home, and often spoke about the wife and daughter of whom he was so proud. His loss to them is that of a friend and protector such as few families ever have; to us, it is that of a friend whose place can never be filled; and to the trades for whose good he studied and labored so long and so well, it will be found, I fear, almost irreparable. They had too few workers for their elevation and advancement before, and the loss of a leader among them will be difficult to make good. Most assuredly there is no man in the entire trade whose death will be more widely and sincerely regretted by craftsmen of every branch, and to us who knew him personally and intimately it comes home like that of a near and dear relative. Let us do our own life work so thoroughly that we may be as deservedly and sincerely mourned as he when the inevitable fate shall come to each of us. "EXCELSIOR."

The Committee on Resolutions then reported that they had selected those submitted by "Excelsior," which were read as follows:

RESOLUTIONS OF RESPECT AND CONDOLENCE.

*Whereas*, it has pleased an overruling Providence to remove from among us our friend and associate, D. H. Hopkinson, late proprietor and editor of THE JEWELERS' CIRCULAR AND HOROLOGICAL REVIEW, therefore

*Resolved*, that as representatives of the watch, jewelry and various related branches of art and industry, we hereby express our sense of the great loss which our trades have sustained by his death. He was indefatigable in his efforts to improve the condition of the workmen and increase their knowledge of their trades, to advise the dealers and advocate a higher standard of taste and business methods, and in general to elevate the trades to that higher and more honorable level befitting their character and importance. His influence for good was great, and to no

one do we owe more gratitude than to him for the improved condition and standing in which we find them to-day.

*Resolved*, that as a business associate and a friend he had our entire confidence and respect, and that he was one of the very few men with whom it is possible to maintain business relations without rubbing off and destroying the tender bloom of friendship.

*Resolved*, that we offer our respectful sympathy to the bereaved widow and daughter in their affliction, and, while we cannot but admit that their grief has good cause, we would also assure them that he left them a spotless fame, a memory without flaw, which they may cherish with pride and affection throughout the years to come.

*Resolved*, that these resolutions be entered and printed in full in our Proceedings.

The resolutions were formally adopted by the Club, and as a mark of respect for the memory of their late patron and friend the meeting then adjourned.

---

### The Dennison Manufacturing Company.

WE HAVE received a copy of a new and elegant catalogue just issued by the above-named company. The front cover contains illustrations of their places of business in New York, Boston, Chicago, Philadelphia and St. Louis, while the back cover gives views of their several factories in Brooklyn, N. Y., Brunswick, Me. and Roxbury, Mass. They manufacture jewelers' findings, morocco, plush and velvet jewelry cases, paper boxes, morocco boxes, jewelry cards, tags, etc. The present catalogue is an exceedingly beautiful one, containing page after page of lithographic illustrations of every variety of jewel cases, representing them in all the gorgeous colors incident to plush, velvet, satin, silk and morocco. The coloring of these numerous illustrations is simply exquisite because so perfectly natural. In each instance the jewel case stands clearly before the eye, the inner lining of bright color in striking contrast to the less pronounced material of which the outside is made. On a single page are exhibited all the colors of the rainbow, and these lend their brightness to the interiors and exteriors of jewel cases of all shapes and sizes. Here a cherry silk lining forms a pleasant contrast to a green plush covering, and here is an orange plush covering is made brighter in contrast with a purple silk lining; old gold plush is set off with maroon silk, and purple is wedded to India red, while a delicate pink plush blushes beside dark green silk. Possibly we have not enumerated these combinations of colors precisely as they are in the catalogue, but that is not the fault of the artist, for he has certainly reproduced to the life the elegant effects in jewel cases for which the Dennison Company is famous. The catalogue contains also a list of other indispensable articles used in the trade with prices for same attached. It is a most useful catalogue for every dealer to have.

---

### How to Make and Engrave Silver Bangles.

BY EXPERT.

THE PENTAGRAPH stippling or dotting machine mentioned in my last communication is neither difficult or expensive to make, and, as suggested at that time, can be used to great advantage with bright cutting. The pentagraph used can be the same as the one already described, the dotting being done by means of an electromagnet; the electric communication is broken by a pattern. This pattern is engraved in heavy sheet zinc with indentations representing the dots made by the magnet. Such work looks well on bangles if the dots are made close together; this is, of course, regulated by the pattern and the proportion to which the pentagraph works—as,



for instance, the pentagraph works to  $\frac{1}{4}$ , if the dots in the pattern are  $\frac{1}{10}$  of an inch apart the dots in the work made by the magnet will be  $\frac{1}{40}$  of an inch; a very nice distance for large work like silver servers or large plated ware but too coarse for bangles. It would be well to change the proportions of the pentagraph from, say  $\frac{1}{4}$  to  $\frac{1}{8}$  as indicated at the dotted lines in fig. 1. There will be no essential change except to make the pieces  $b c$  proportionately shorter as the same joints can be used. It would be well to make new short pieces for  $b c$  so the machine can be restored to  $\frac{1}{4}$  scale readily. What would be best for persons who would use such a machine would be to have two sets of  $b c$  for the two scales. The tracing point situated at  $d$  serves the double purpose of following the design and of breaking and closing the circuit for every puncture in the pattern. I will first describe the manner of making the pattern and then tell how to use it. The design is first traced on the zinc plate and then cut with a large fish-belly graver (the cross section of such a graver is shown at  $D$ ); after a firm heavy line is established a series of heavy punctures are made at regular intervals; these serve to break the circuit as will be explained further along. These punctures are laid out by spacing with bow dividers set at say  $\frac{1}{10}$  of an inch which will give 80 to the inch in the copy; this is quite close enough for any purpose. The indentations are just pricked so as to be visible and then a punch is used to deepen the pits. It will require a little practice to get quite the right shape for the pits, and even then the shape and depth of the pits are modified by the size and form of the tracing point, but a few experiments will soon put one on the right track. The tracing point is fitted to the joint at  $a$  as described for

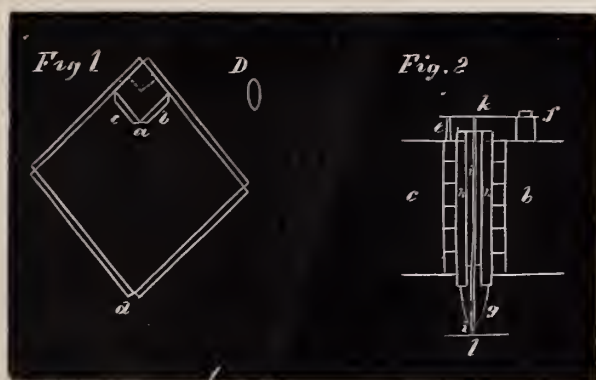

the cutters for making bosses, only the point is hollow and permits a needle to pass through which acts mechanically to break the circuit. A magnified vertical section of the tracing point is shown at fig. 2; it consists of a hollow tube  $h$  large enough to fit the joint with a steel plug screwed into the lower end as shown at  $g$ . The hollow in the tube  $h$  should be about  $\frac{1}{8}$  of an inch in diameter, and the hole through  $g$  for the needle  $i$  to pass through about  $\frac{1}{10}$  of an inch; this would make the hollow conical point of  $g$  about  $\frac{1}{40}$  at the point where it follows the lines in the pattern. The upper end of  $h$  can be bushed to fit the needle  $i$  and keep it steady. A stud  $f$  is attached to the joint to which is fastened a platinum spring  $k$ ; this spring  $k$  acts to force the needle  $i$  downward, and also acts as circuit closer when it is permitted to touch the platinum stud  $e$ . It will be seen on inspection that if something is pressed against  $i$  at  $l$  that the spring  $k$  will be lifted from  $e$  and the circuit broken. The action is briefly this: as the point  $g$  runs along the lines in the pattern, the shallow groove will press the needle upward and open the circuit by removing  $k$  from  $e$ , but when the point  $g$  comes to one of the pits punched in the pattern it will allow the fine point of  $i$  to drop into the pit, and  $k$  will touch  $e$  and the electric circuit is established, and a blow is given by the force of the magnet. Now, what we have to do is to arrange so the force of the magnet charged will produce the punctures in the work in hand. It is necessary to have the battery force sufficient to make the blow instantaneous or the work will be irregular. A few words about batteries may not be amiss. We have a great variety of batteries to choose from, but we must select one adapted to our wants; in the present case we want a current of what

is known as quantity, or, as some term it, dynamic force. Most jewelers know something about a battery and use one for gilding; but aside from putting the zincs and carbons in the solution they are comparatively ignorant. The best battery for such a purpose is the Grove, and even for gilding a Grove is superior, only keeping in mind that it is a very powerful battery, and for gilding small articles it is not policy to immerse all of either the zinc or platinum. In caring for a Grove battery it is necessary to keep the zincs amalgamated; this can be done by first brushing with a stiff brush and dilute sulphuric acid and quicksilver. After the zincs are once amalgamated if they are washed and set in water with a little quicksilver in the bottom of the dish in which the zinc can touch the quicksilver they will remain amalgamated. The principal object in amalgamating the zincs, is the acid does not dissolve or waste the zinc except the current is actually passing. A Grove battery has the outer cell filled with dilute sulphuric acid (about  $\frac{1}{10}$  acid), and inside the porous cell filled with nitric acid of full strength. When the battery is in operation the inner cell gives off strong nitrous acid fumes; this is of only slight inconvenience when one or two pairs of cells are used. The nitrous acid fumes can be avoided by shutting the battery up in a close box in which there is an aperture for the escape of gas, closing this aperture loosely with a lock of cotton wet with alcohol. About 24 or 36 hours constant use will exhaust the strength of the nitric acid in the inner cell, consequently it should be thrown out and fresh put in. The way to do, however, when a battery is not in constant use is to have a large mouthed bottle into which you empty the nitric acid from the inner cup, rinsing out the porous cup, leaving the dilute sulphuric acid in the outer cup. If the battery is to be used for coloring, *i. e.*, lightly gilding small articles of jewelry, only leave dilute acid enough to fill the outer cup, say one-third full. For such a stippling machine to work the magnet well we should have 3 Grove cups; now, on getting through with our work we take out the inner nitric acid cup and empty it as directed above, remove and wash the zincs, setting them into a dish of water with a little quicksilver on the bottom; we would now have three glass cups a trifle over half full of dilute acid. Suppose we wish to use a single cell of low power, we pour from one of our cups a portion of the dilute acid leaving enough so that when the zinc and porous cup is in to  $\frac{1}{4}$  fill the outer cup; now put in nitric acid enough in the inner cell to have the fluids in the two cells of the same height. Now, on immersing the platinum in the inner cup we have a battery of sufficient power to gild any article as large as a thimble, while a full cell will be ample for a cup or watch case. I have been led to speak of a battery to this length for the reason I believe that a Grove battery is even for ordinary jewelers' work, if properly understood, the best in use, all things considered. The arrangement of the magnets and stippling point must be reserved for our next.

## Lathes and Lathe Work.

BY THE MODEL WATCHMAKER.

IN THE description of our tool making lathe I shall endeavor to give the best manner of arranging the parts, and afterward point out how they may be varied without materially detracting from their accuracy. I spoke of lining up the centers in my last communication and will beg permission of the reader to continue the subject in this. I remarked in last article that it was the usual practice in lathe work when it was desired to turn taper, to shift the line of centers at one end as shown in fig. 2 at diagram  $B$ , from line  $g a$  to  $b a^2$ , and also indicated in fig. 1 by the lines  $h j$ . The cylindrical piece shown at  $e$ , fig. 2, will show the position of a piece to be turned taper. At diagram  $E$  is shown a magnified relation of the piece to be turned and the position of the conical center. At  $f$ , diagram  $F$ , is shown a dotted line which corresponds to the face of the end of the piece to be turned. Now, it will be seen that a section of the

cone  $F$  on the dotted line  $f$  cannot be round but shaped as shown at  $G$ . Working against this is a round hole slightly countersunk, or in other words, the round countersink in the end of the piece  $e$  is working or turning on an ellipse which precludes all steadiness. We can see from these illustrations and a little study of the subject that to secure steady and secure tracings that the axis of the two centers must be kept in line if we desire to do accurate work. We will now resume the practical part of fitting up the parts. In my last communication I described the method of trueing up the lower face of the head  $H$ , fig. 3, on the dotted line  $kl$  (which represents the upper surface of the ways); to get the face of one of these heads when the centers go at right angles a piece of plate glass can be laid on the ways and a try square used as shown at  $n, l$  representing the head and  $n$  the try square, and  $i$  the piece of plate glass. This method will secure the face of the head  $I$  being in a vertical plane and at right angles to the ways  $L R$ , fig. 4. We next come to lining up our centers; this can be done with sufficient accuracy by the following method: The heads  $I P$ , fig. 5, are held in place on the ways by the bolt  $p$  and nut  $r$  as shown in transverse section at diagram  $M^*$ ,  $s$  being a bar extending across the bottom of the ways. At diagram  $R^*$  is shown the bottom of one of the heads (sav  $P$ ), to

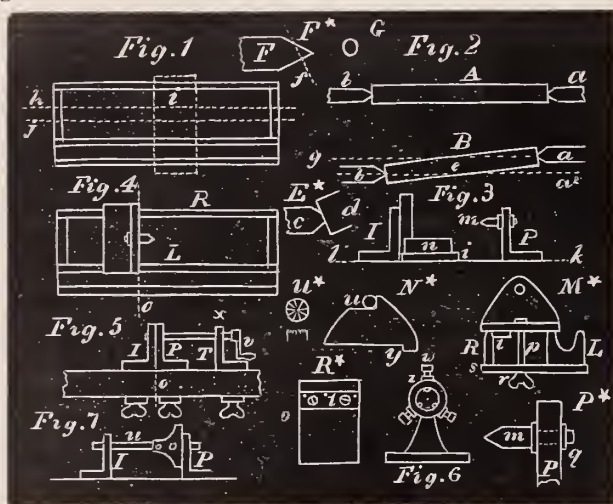

this is secured a guide piece  $t$  with two screws and three steady pins; this guide is intended to slide against the back way shown at  $R$ , fig. 4. Both heads are provided with such guides and serve to instantly place the lathe in condition to turn a perfect cylinder, *i. e.*, a piece of the same diameter from end to end. We next place our two heads face to face as shown at  $P I$ , fig. 5. In  $P$  is drilled a hole say  $\frac{1}{2}$  an inch in diameter where we want our center to be. We next drill a hole in  $I$  about  $\frac{1}{16}$  as near opposite to this hole as we can. We now provide a piece of round Stub's steel  $\frac{1}{2}$  inch in diameter to fit the hole in  $P$ . It is not particularly important that the hole in  $P$  or the rod  $u$  should be exactly  $\frac{1}{2}$  an inch but they should perfectly fit, *i. e.*, the rod  $u$  should exactly fit the hole in  $P$ . We now make a back rest for our lathe as shown at  $T$ , fig. 5. I have described such a back rest in former articles, but for those who have not such back numbers I will give the simplest form of back rest known to the writer and in some respects the best. This will be understood by inspection of figs. 5 and 6. Fig. 6 is an enlarged view seen in the direction of the axis of the lathe. The piece is cast very similar to the heads except it has a narrow neck above  $T$  as shown in fig. 6. The hole in the center should be about 1 inch in diameter (it would be well to make also a larger one 2 inches in diameter), provided with 3 screws as shown at  $w$ ; these screws have jam nuts shown at  $z$  to hold them firm in position. These screws are set at 120 degrees. The round rod  $u$  is placed as shown in fig. 5 and the back rest put in position. A templet is now made of sheet iron or zinc shaped as shown in diagram  $N^*$ . The notch at  $y$  going against the way  $R$ , fig. 4, and the notch at  $u$  defining the position of the rod  $u$  in fig. 5, when placed on a plane with the dotted  $o$ . It is, of course, understood, that the back rest is placed as near correct to start with as possible. By means of the screws  $w$  we

manipulate the rod so that the templet  $N$  can be placed on the dotted line  $o$  or immediately in front of  $T$ , and it indicates that the rod  $u$  is parallel to the ways. The end of the rod  $u$  is now filed into notches or teeth as shown in diagram  $U^*$  and hardened. Now, by means of the crank  $v$  we can by turning and pressing forward soon ream out the hole in  $I$  to exactly correspond to the hole in  $P$ . We can now separate the heads  $P I$ , and if the guide  $t$  on each rests against the inner edge of the way  $R$ , the center of the holes in  $P$  and  $I$  will be at equal distances from the ways. We will next provide centers for the heads  $P I$ . These we could have made with a good deal of propriety, but it has been the writer's aim to point out how such a lathe can be built (except planing and grinding the ways) independent of any outside help. We will want a piece of  $\frac{3}{8}$  steel rod for our centers, and as the holes in the heads are  $\frac{1}{2}$  inch we can leave a flange  $\frac{1}{16}$  of an inch to steady the centers. At diagram  $P^*$  is shown at  $m$  a center,  $P$  representing a vertical section of one of the heads; at  $q$  is shown a nut that draws the flange on  $c$  firmly against the face of the head. What is wanted, now we have the two holes in our heads, (these holes having their centers parallel to the ways), is to have the faces of the two heads exactly at right angles to the extended axis of the two holes. It is of great importance in fine lathe work that the centers should line; consequently we will dwell at some length on this point. If the face of the heads are dressed up first to the perpendicular line  $o$ , fig. 5, and then to the horizontal line  $o$ , fig. 4, the centers must line. The line  $o$ , fig. 5, is obtained as shown by a try square; the other is got by mounting a T-head on the bar or rod  $u$  as shown in fig. 1. The reader will see that the T-head is screwed to  $u$  with two screws, one of which acts as a set screw (working in a loose hole); the front edge of the T-head is pressed against  $P$  which has been trueed up with the try square as shown in fig. 3. Of course it is understood that the T-head is first tried and set when perpendicular as shown in fig. 7. By revolving the rod  $u$ , and filing and scraping we can make the faces of  $P I$  at right angles to the axis of the two heads. Now, by placing a temporary center in one of our heads we can, after our slide rest is made, proceed to turn and fit a set of good centers. A slide rest must first be provided with a transverse screw; this, as I remarked early in these papers, you will get some machinist to turn up for you; the size and shape we will give in our next.

## A Review of the Experiments of the Old Masters of Horology.

IT is the duty of every watchmaker of the present era, when he contemplates the perfection of the timepieces manufactured, to remember the grand old masters and predecessors of his art, who by force of reasoning, researches, experiments and trials, sought to find a grain of truth in the labyrinth of error, and he should make himself acquainted, at least in part, with the methods they discovered to enable him to construct a chronometer that shall not deviate more than the one-tenth part of a second in twenty-four hours. We will commence with the various rules on the

### I. REGULATOR.

It is known that the velocity of the balance vibrations depends upon the power of the balance spring, and that these vibrations increase in speed with the power of this spring and diminish with its decrease. The power of the balance spring depends upon the thickness, breadth, and length of its blade, or its coils. Supposing that the thickness and breadth of the blade be given, then the power varies according to the length of the latter, so that the spring gains in power when the blade is shortened, and *vice versa*, it becomes weak in the ratio of increase of the blade.

In order to produce a definite number of vibrations of the balance, a balance spring of an appropriate power must be used, which

approaches nearest to the required number of vibrations; but in order to produce the extremest point of uniformity, the regulator must be employed, which, by lengthening or shortening the outside coil of the spring, develops more or less power, according to requirement. In the following paragraphs we will seek to become better acquainted with the very simple mechanism of the regulator.

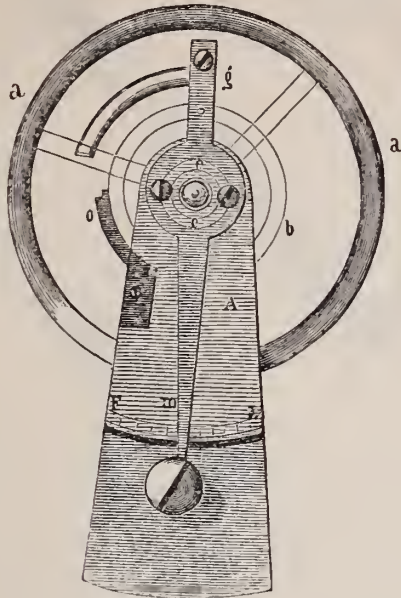

FIG. 1.

Fig. 1 represents the balance *a a*, with its balance spring *b*, the outer coil of which is, through *o*, fastened to the cock, while its innermost coil is fastened through the collet to the staff of the balance. On the bridge *A*, is the piece or button *e e*, which serves at the same time as the hole of the balance pivot. The piece *g m*, the regulator, is fitted with small friction upon this button, so that the end *m* can sweep through the arc from *F* to *L*, the other part *g* will in this manner follow a part of the outer coil of the balance spring. Two screws located on this button *e e* prevent with their heads the raising of the regulator, and they at the same time retain the bridge cap jewel in place, against which the end of the pivot runs. In fig. 2 we see the bridge from below and the balance spring in that position

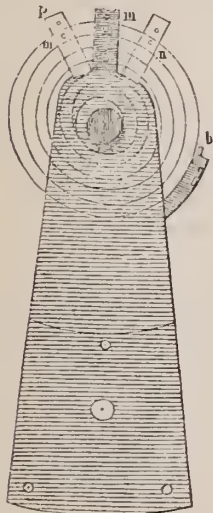

FIG. 2.

it would have if fastened to the balance or its staff; it shows the regulator arm with its two curb pins, *m* and *n*, which embrace the outer coil of the spring; this has only very little shake between the two pins which keep the part *b* of the balance spring from having free play during the vibrations of the balance spring, while the entire other part of the balance spring is active, when the balance is in motion. It will be seen thereby that when the regulator is moved towards *p*, the operating part of the spring is decreased, whereby this becomes stronger and vibrates quicker; if the operative part of the spring is lengthened, however, by pushing the regulator toward *b*, then the spring becomes weaker and its vibrations slower. A greater or smaller velocity may in this manner be given to the balance, according to the quantity necessary.

The two curb pins, therefore, are, as we have seen, only a little distant from each other. If this distance were large enough so that the balance spring blade could not touch these pins even during very large vibrations, it is plain that they would be useless, and their effect will increase with their close position. If we assume one of these pins to be movable, in order to increase or decrease the play of the spring blade, it is very plain that it would have an influence on the duration of the vibrations, and that the pins, by opening them,

would lessen the velocity of the balance, while if closing them, the vibrations would become quicker.

2. ON THE INFLUENCE OF HEAT AND COLD UPON THE BALANCE AND SPRING, BY JURGENSEN.

We have seen formerly how the isochronism of the pendulum oscillations is disturbed by the changes of the temperature; the isochronism of the vibrations of the balance is subject to a still higher degree to these disturbing causes. The changes of the pendulum are solely due to the expansion and contraction of the pendulum rod; but those of the balance are not alone caused by the expansion and contraction of the balance, but also by its influences upon the balance spring. Heat increases the size of the balance, lengthens the balance spring, and these two modifications united cause slower vibrations and the retardation of rate.\* These changes are very noticeable even in watches intended for everyday use, and these are the kind of timepieces that can be controlled by a compensation of the balance spring, because it could not be employed for marine timepieces and in no manner produce that uniformity demanded of this kind of mechanism. It becomes necessary, therefore, to use for them the most perfect kind of compensation, being that obtained by the balance itself.

a. SIMPLE COMPENSATION OF THE BALANCE SPRING.

In order to correctly understand the effects of the compensator employed upon the balance spring, it becomes necessary to have recourse to illustrations, showing what effect is produced by heat and cold upon two metallic rods, connected with each other in the manner shown in fig. 3: *A B* represents a composite rod, one side, *a a*, of which consists of brass and the other, *b b*, of steel, both metals being soldered together. When this composite rod is exposed to the influence of heat, the two metals will expand; but we know that brass expands more than steel, consequently the rod *a a* will elongate more than the rod *b b*, and bend the composite rod in a direction towards *D*, supposing the lower end *A* to be fixed and the upper end *B* movable. If, again, the rod is exposed to cold, the opposite will take place; *a a* will contract more than *b b*, and force *B* in a direction toward *C*. This motion of the composite rod is very noticeable; to ocularly observe it, it suffices to heat such a rod above the flame of an alcohol lamp, when this torsion can be easily noticed.



Next, let us suppose this composite rod to have the shape of *A B C D*, fig. 4, the outer part of steel the inner of brass. Let us then assume the part *B* to be fixed, then the part *A* will twist toward *C* by the operation of the heat, and thereby the part *D* will move toward *e*; but when the heat continues to operate upon the part *C D*, the effect will augment so that the entire motion of *D* becomes considerable, in ratio with the degree of heat to which *A B C D* is exposed. The direction of the motion of *D* when *A B C D* is exposed to cold is altogether opposed to that explained just now, and *D* moves in a direction toward *f*, or what is the same, approaches toward *B*, while heat removes *D* from *B*. Heat opens *A B C D*, cold closes it. From these statements we know that less shake between the curb pins causes quicker vibrations, and that, again, more shake lessens the speed of the vibrations, if the compensator *A B C D* is applied to the regulator, so that the part *B* is fastened

\* This was, of course, written at a time when the principles of isochronism were but imperfectly understood, and the masters of that day are fully excusable for entertaining such erroneous opinions, but no such forbearance is due to the watchmakers of the present time. It should be universally known among the craft everywhere that neither the increase or decrease in length, nor the effects of heat or cold have such influence as that spoken of in the above article, but retardation or acceleration by heat or cold are caused by the alteration of the crystalline structure of the spring; heat softens the steel and lessens its elasticity, cold draws its crystalline structure together and increases the latter.

with a screw and a foot upon the regulator, while part *D* remains movable it will be seen, by examining fig. 5, that the performance

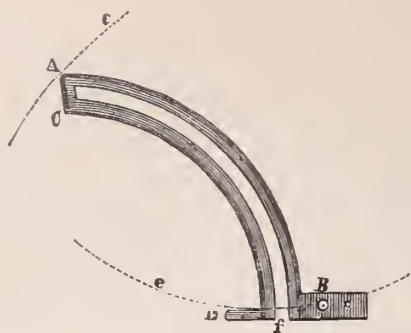

FIG. 4.

of the balance spring varies upon this compensator according to the influence of the temperature. In heat, *D* approaches the fixed pin, *c*, and the balance spring will have less freedom. In cold the opposite effect will take place and the spring have more freedom of action,

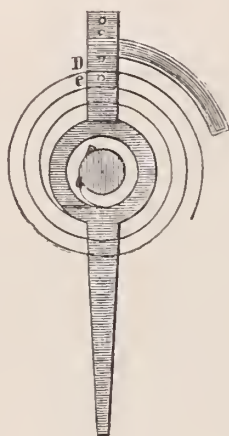

FIG. 5.

The operation of heat upon the balance and spring, which makes the vibrations of the balance slower, will be compensated by the closing of the pins, and the effect of cold, which increases the velocity of the vibrations, is also compensated by the opening of these pins. This compensator operates, as we have seen, in a very simple manner, and can successfully be used everywhere, whenever only an approximate correctness of rate is required from watches used in everyday life.

*b.* COMPENSATION BY THE BALANCE.

The most perfect kind of compensation is that obtained by the balance itself, and from this alone a correct rate can be expected in changeable temperature. The principle of compensation by the balance is very simple and ingenious, because the heat, which would decrease the speed of the balance vibrations, at the same time diminishes the balance diameter, so that the center of the oscillation approaches to the center of motion by that quantity necessary to produce a perfect compensation. Cold, however, would accelerate the vibrations, but, since the balance diameter augments at the same time, the center of oscillation sufficiently removes from the center of motion, so that a good compensation is again established.

Fig. 6 represents a compensation balance; *ea* and *eb* are the balance arms which carry the two arcs *ac* and *bd*, concentric to the balance axis, and at their ends are furnished with the weights *c* and *d*. The arcs *ac* and *bd* are composed of two metals of different dilatability, of which the inner one expands and contracts less in heat and cold than the outer. After remembering what has been heretofore said about the composite rods, it will be seen that heat causes the compensating weights *c* and *d* to approach to the center of the balance, while cold removes them, and owing to this motion we are able to compensate the effects of changes of temperature.

According to the greater or smaller length of the composite rods and the greater or smaller weight of the composite weights, the composition will be more or less strong. If the rods are of a small

length, then the weights *c* and *d* will in heat describe smaller and in cold larger arcs, and in this manner approach nearer to or remove from the balance center, which alters the center of oscillation essentially. Heavier weights, therefore, will produce a stronger compen-

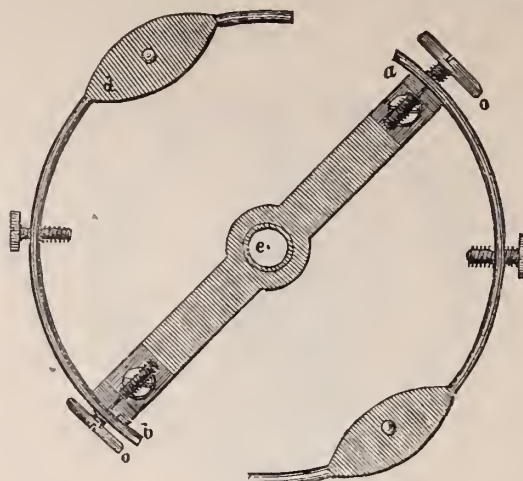

FIG. 6.

sation than lighter ones. It is plain, therefore, that the compensation can, according to necessity, be made more or less strong, and if, for instance, it was found that the compensation be too strong, it would only be necessary to move the weights *c* and *d* toward or from *a* and *b*. If, again, the compensation should be too weak, recourse could be had to removing *c* and *d* from *a* and *b*; should this not be sufficient, then the weights of the compensating bulks would have to be increased. The screws *a* and *b* or *oo*, which are fastened in the direction of the balance arms, serve for regulating the velocity of the latter; by moving them to the balance center the vibrations become more rapid, and removing them therefrom they will become slower. Fig. 7 shows the piece carrying the regulating screw, and fig. 8 gives



FIG. 7.



FIG. 8.

both the regulating screw and the piece. It is barely worth mentioning that both figures were considerably enlarged, on account of showing plainly the disposition of the parts.

This, therefore, are the means employed for compensating the injurious effects of the changes of temperature upon the regular rate of the watch. It is necessary to remark, however, that an exact compensation can be produced only after repeated trials, together with the strictest compliance with a number of minute details.

*c.* PRACTICAL EXECUTION OF THE COMPENSATING PARTS OF A BALANCE.

The compensating parts of a balance require a great exactness in their execution. The corresponding opposite parts must be strictly of the same size and weight, and the composite must be exactly concentric to the balance axis. They must also be truly of the same length, and the compensating weights are to be located in such a manner that the distance from the center of one weight must be from that of the other exactly the one-half of the circumference of the balance, or what is the same, these weights are to be placed exactly within one diameter of the balance. It is impossible without these provisions, that the balance preserve its equilibrium during the varying temperatures; because, if we suppose that the equilibrium has been established at mean temperature, then an inequality in the motion of the rods caused by a greater degree of heat or cold will move one of the compensating weights more to the center, or remove it therefrom, then the other one and the balance will no longer be in equipoise, which has a very injurious effect upon the rate of the watch, especially if intended to be worn, and consequently is kept in a vertical position.

As far as the choice of the metals of which the compensating balance is made is concerned, it is well to take two metals of very different degrees of dilatibility so that a sufficiency of counteraction of the two rods takes place, and producing the necessary compensation. Steel and brass are generally used, and by hardening the steel, the balance obtains more solidity, retains its shape better and is not so easily exposed to the danger of being bent. Other artisans of the trade construct the rods of platinum and brass, but this method, although very good, is not employed at present.

It is very important that the two metals forming the compensating rods be united very firmly, because in case that they should not adhere most perfectly, irregularities in their movements would take place and consequently in the rate of the watch. The method of fusing brass around steel is generally done in England; it is a good one, although equally as good is to solder the brass and steel together with silver solder; care is only necessary that the layer of solder uniting the two metals be equally thick everywhere around the circumference of the balance.

**The Jewelers' League.**

*President*, GILBERT T. WOGLON.....Of Woglom & Miller.  
*First Vice-President*, WM. C. KIMBALL.....Of H. F. Barrows & Co.  
*Second Vice-President*, AUG. KURTZEBORN.....Of L. Bauman Jewelry Co. St. Louis, Mo.  
*Third Vice-President*, JAMES P. SNOW.....Of G. & S. Owen & Co.  
*Fourth Vice-President*, HENRY HAYES.....Of Wheeler, Parsons & Hayes.  
*Secretary and Treasurer*, WILLIAM L. SEXTON.....Of Sexton & Cole.

**EXECUTIVE COMMITTEE.**

ROBERT A. JOHNSON, *Chairman*.....Of Colby & Johnson.  
 SAMUEL W. SAXTON.....Of Saxton, Smith & Co.  
 CLEMENT B. BISHOP.....Of Carrow, Bishop & Co.  
 JOSEPH B. BOWDEN.....Of J. B. Bowden & Co.  
 GEORGE R. HOWE.....Of Carter, Sloan & Co.  
 CHARLES G. LEWIS.....Of Randel, Baremore & Billings.

THE JEWELERS' CIRCULAR is the *exclusive* official paper of the Jewelers' League, and has been selected for the publication of all matters of interest pertaining thereto. Letters or inquiries pertinent to its business or purposes, and which might interest the trade or inquirers, will herein be answered. Address *Jewelers' League, Box 3,444, P. O., New York*, or the office of THE CIRCULAR.

At the regular meeting of the Executive Committee held Aug. 1st, 1884, there were present Vice-President Kimball, and Messrs. Johnson, Bowden, Howe and Sexton.

A double assessment was ordered on account of the deaths of H. W. Hurlburt, of Hartford, Conn., and George Frantz, of New Orleans, La.

- Two (2) members were reinstated.
- Seven (7) changes of beneficiaries were granted.
- Two (2) applications were rejected.
- Three (3) applications were referred.

The following twenty applicants were accepted:

M. L. Strasburger, H. H. L. Siebenerchen, F. H. Schultz, M. T. Rice, L. H. Cohn, New York City; F. S. Searles, Mt. Vernon, N. Y.; E. L. Heaton, Canton, N. Y.; F. Bauer, Pittsburg, Pa.; C. H. Barber, W. Philadelphia, Pa.; E. E. Parmelee, Meriden, Conn.; C. W. Hoyt, A. Clark, Stamford, Conn.; C. A. Ring, Waltham, Mass.; A. L. Lilienthal, Boston, Mass.; J. F. Teichner, Detroit, Mich.; T. J. Rodgers, New Orleans, La.; I. B. Callahan, Cincinnati, Ohio; J. H. Gilbert, Kansas City, Mo.; A. S. Bleyer, Central City, Neb.; J. F. Pietz, Fort Wayne, Ind.

The following resolution, out of respect to the memory of the late D. H. Hopkinson, was unanimously adopted:—

“It having been the edict of an omniscient Deity that our friend and brother D. H. Hopkinson should be removed by death from the fraternal, business and social circles of which he was such a useful member, we bow with resignation to the Divine will.

“Of our late associate we shall ever retain a pleasant memory.

As a member of our League he was active in any enterprise tending to promote its interests. In his capacity as editor of a widely known journal his pen was at all times ready and earnest in advocating the merits of the League in its benefactions to widows and orphans; in his business prompt, affable, considerate, kindly; in his social habits most genial, and painstaking in all the elements which tend toward an elevated, pure-minded plane of life.

“In this loss we have met with one which is well nigh irreparable; mourn it as we may, however, it can but appear as a contrast with that of his widow and child, with whom we join in sorrow and to whom we extend our heartfelt sympathy in their bereavement.”

**The Jewelers' Security Alliance.**

*President*, DAVID C. DODD, JR.

*Vice-President*, AUGUSTUS K. SLOAN.....Of Carter, Sloan & Co.  
*Treasurer*, W. C. KIMBALL.....Of H. F. Barrows & Co.  
*Secretary*, C. C. Champenois.....Of Champenois & Co.

**EXECUTIVE COMMITTEE.**

C. G. ALFORD, *Chairman*.....Of C. G. Alford & Co.  
 C. B. BISHOP.....Of Carrow, Bishop & Co.  
 HENRY HAYES.....Of Wheeler, Parsons & Hayes.  
 J. B. BOWDEN.....Of J. B. Bowden & Co.  
 DAVID UNTERMAYER.....Of Keller & Untermeyer.  
 E. F. DORRANCE.....Of Dorrance & Brother.

P. O. Box 3277.

Room 2, 170 Broadway, New York.

HON. ALGERNON S. SULLIVAN, *Counsel.*

THE REGULAR meeting of the Executive Committee was held at the office of the Alliance, 170 Broadway, on the 8th inst. There were present Messrs. Dodd, Sloan, Kimball, Alford, Bowden, Dorrance and Untermeyer.

The reports of Standing Committees were received and other routine business transacted. The quarterly report of the Treasurer was read, showing a steadily increasing general fund.

Action was also taken relative to the death of Mr. Hopkinson by the Chair appointing a Committee of Three, Messrs. Dodd, Sloan and Dorrance, to draft suitable resolutions to be tendered to Mrs. Hopkinson and placed on the records of the Alliance.

The following applicants were admitted to membership, viz.:

F. Kramer & Son, Baltimore, Md.; Geo. H. Morrill & Co., Boston, Mass.; Martin, Copeland & Co., New York City; Mason, Draper & Co., Attleboro Falls, Mass.; J. F. Pietz, Ft. Wayne, Ind.; Ernest Peschke, Macon, Ga.; Simons Bros., Columbus, O.; W. P. Sedgwick, Bath, N. Y.

NEW YORK, August 8th, 1884.

*Dear Madam:*

At a meeting of the Executive Committee of the Jewelers' Security Alliance, held at their room August 8th, a Resolution was adopted expressing the feelings of the Committee in view of the death of Mr. Hopkinson;

And a Committee was appointed to express to you our Sincere Sympathy in your great loss, feeling that we were not rudely trespassing upon the sacred precincts of your home, when we expressed our esteem and high regard for your deceased husband.

By his kind courtesy, his manly qualities, his high sense of honor, his interest in all that pertained to the welfare of the Jewelry Trade, he secured for himself the highest regard, not only of our Board, but of the entire Jewelry Trade.

Words but tamely express feelings on such an occasion, and we can only tender you our deep sympathy in this your irreparable loss.

Signed, { DAVID C. DODD, JR.  
 AUGUSTUS K. SLOAN.  
 E. F. DORRANCE.

## Review of the Different Gravity Escapements.

(Continued from May number.)

THE SCAPE WHEEL of the Dennison escapement is recently constructed with three, four, five and six prongs. The double three-pronged escapement, however, is used mostly, of which we add a sketch. Such an escapement is absolutely perfect for the larger kinds of steeple clocks, and on account of the larger number of prongs the wear and tear caused by hooks, etc., is here reduced to a minimum. The escapement itself consists of two separate three-pronged wheels, between which lie the arms  $m$  and  $n$ , and corresponding to this are also located the points of detent  $q$  and  $p$ , the shoulder  $q$  lies in front, and only operates upon the prongs  $A B C$ , while the shoulder  $p$  lies behind  $m$ , and only acts upon  $a b c$ . (C



does therefore not stand in contact with  $p$ , as would appear from the sketch.) Both detents are arranged in such a manner that the radii of the scape wheel form right angles with the arms  $m$  and  $n$ ;  $w w$  is the fly.

When the distance  $d$  of centers is a little smaller than  $2a$  ( $a$  is the length of tooth,) the points of contact of the scape wheel lie then truly in a hexagon; this is of no importance, however, but the reason why  $d$  is not exactly equal to  $2a$  in this case is because the axis of  $m$  and  $n$  are necessarily separated from each other, and the theoretical center, therefore, lies a little above the real.

The advantages of this escapement consist in that by the longer teeth and shorter arms  $m n$ , the resistance offered to the pendulum by pressure and friction is reduced and the drop of the arms is greater, and therefore their necessary effective weight becomes essentially smaller. This reduction of weight, or rather, diminution of the moment of inertia and of the blow upon the pendulum, or the friction upon its pivots is of the greatest importance, and much contributes to the constant operation of the pendulum. More recently, this double three-pronged escapement is also used for smaller clocks, and the six prongs are then made of wire, the elasticity of which is intended to prevent the blow upon the pendulum at each oscillation.

The pins for unlocking, close at the center of the scape wheel, are formed of a toothed wheel of six teeth, each second tooth of which is filed out.

*The four-pronged scape wheel.*—The same end, even if not as perfect, may also be obtained by a simple wheel with four prongs or teeth and eight unlocking pins, for the alternating forward and backward motion. The banking pins  $q$  and  $p$  are then also in different planes.

In this escapement the length of the scape wheel prongs and of the levers  $m n$  is not optional as is the case with the three-pronged, but it depends upon several geometrical axioms. If we designate with  $a$  the length of the teeth, and with  $d$  the distance of the theoretical center from the arms  $m n$ , we will find  $d = 2.6a$ , and  $p$  the distance from the lever center to the banking points equal to  $2.4a$  (with the

double three-pronged only  $1.73a$ ). The power necessary for a four-pronged scape wheel, therefore, is almost double as large as for a six-pronged, and smaller than for a three-pronged.

The four-pronged escape wheels as already said, operate perfect, although not as uniform as the double three-pronged in large clocks, which always contain a large quantity of superfluous power. The four-pronged escapement is employed for regulators, and the absolute weight of the levers is also lessened in them.

[THE END.]

## Advice to Watchmakers' Apprentices.

BY A MAN WHO HAS SPENT TWENTY YEARS AT THE BENCH.

AMONG THE old scraps of gold which accumulate in a jewelry store are many pieces which are more or less contaminated with soft solder, and as a very small amount of this material will render gold unfit to work, it stands one in hand to look out that none gets in with the scrap we melt. It is well to put all such bits as show any trace of this precious substance into a box by itself and treat it in the following manner: Take 4 ounces of muriatic acid and add  $\frac{1}{2}$  an ounce of crocus; put these two ingredients into a bottle and shake them well together. Put 1 ounce of this mixture into 4 ounces of boiling water in an ordinary tea cup; put the scrap gold contaminated with soft solder into the tea cup and keep the mixture hot over a lamp or gas jet and in a few minutes all the soft solder will be dissolved off leaving the scrap fit to be melted with other scrap gold. In a former article the writer gave a method of melting, and promised some future time to give additional methods for refining scrap and gold which worked badly. It is a business of a lifetime to be a proficient in gold melting, so many details have to be mastered; trifles in themselves but still going a long way in making up the sum of knowledge necessary to the gold worker. Economy is one essential thing in all jewelry repair shops. Save your scraps and filings; pick out all the scraps large enough to be picked up with the tweezers and put into your scrap to be melted. In regard to filings you should have a good-sized steel magnet to pass through your filings to remove all iron and steel filings and chips. The manner of using the magnet is to simply run the two poles of the magnet back and forth through the pan of the bench at which you work, brushing off the particles of iron as fast as they accumulate, letting the iron filing go into the sweep as they will mechanically carry away some gold. The sweepings of even a small place is far more valuable than most persons would imagine and should be carefully saved. The floor of a jewelry repair shop should be carefully laid to avoid cracks and corners. The best way if a floor is to be laid new is to have the plank of which the floor is to be laid well seasoned and quite narrow. After the floor is laid it should be well oiled with boiled linseed oil or painted with oil paint, and the cracks puttied with hard putty composed of white lead and coach varnish—the kind of coach varnish known as rubbing varnish—the puttying should be done after the oil is applied or the paint put on. The varnish putty is difficult to use as it dries very quickly; keep it under water except as fast as you use it. If you have an old floor full of cracks put sheet zinc over the whole floor where you work; let the sheets lap well, and if a hole wears through put a piece over it as soon as seen. A common soft wood floor will hold an unbelievable amount of scrap and filing to say nothing about the cracks. This is true also of oil cloth, and an old oil cloth which has been on the floor for any length of time should be burned and the ashes put into the sweepings. Scraps of paper and old match sticks lying on the floor should all go into the sweepings. These sweepings should be put in a tight box or barrel until enough have accumulated (say a barrel or two) to pay for burning. The way to burn sweepings is, if you use a stove clean it out when you are going to burn a lot of sweepings, and put the dirt with the scraps of paper in a little at a

time until all is reduced to ashes. A barrel of sweeping will be reduced in this way to two or three quarts; this reduction is another economy when you come to send it to the sweep smelters which it is better to do than to try and recover the precious metals it contains yourself. Such a melting furnace as the writer described in a former article is a good place to burn sweepings in. The residue of three or four barrels of sweeping can be put in an old paper flour sack, and the flour sack which will not permit a particle of anything it contains to escape can be put in a quite small box and shipped to your sweep smelter whom you will notify of the shipment and mention how you treated your sweep. After burning such a lot of sweepings you of course will be careful to remove every particle from the stove or furnace, as the gold being heavy will fall to the bottom. A person working gold or silver should brush his clothes and apron with a bristle clothes brush kept for this purpose before leaving his work. Filings can be treated as follows: It should be melted by itself with a flux composed of two parts of carbonate of potash (*sal tartar*), and one part of nitrate of potash (*saltpeter*). This flux will remove the iron and steel particles which escaped the magnet. The button of gold should be remelted with sal ammoniac and charcoal powder and cast in the ingot mould. If on attempting to roll it it cracks, it is a pretty sure indication that some lead or tin is present; but if the precaution given above is taken of treating the suspected scrap with the muriatic acid and crocus there is very little danger but the gold will come out in condition to roll and work well; but if it does crack remelt it with a flux of charcoal and corrosive sublimate, two parts (by weight) of charcoal to one of corrosive sublimate. This treatment will destroy the last trace of lead or tin. Sometimes one will get hold of old gold pens with iridium points; these points should be carefully removed as they are pernicious things to get into gold you have to work, being so hard that a file will not touch them, and they will also indent the hard steel rollers. If only one or two such points get into an ingot they should be instantly cut out with a small cold chisel. But if quite a number of such points should get into a lot of gold the way to proceed is to remelt the lot in a crucible which has a strongly marked hollow conical bottom. The heat should be raised (using fine charcoal as a flux) until the gold is rendered very fluid. The crucible should now be removed from the fire and allowed to cool. On removing the button from the crucible all the pen points will be found to have settled to the bottom of the crucible, and now are congregated at the very apex of the cone of the gold button. The reason for this is that iridium being heavier than gold (and not melting as easy), when the gold was in a melted state settled to the bottom. The part of the button containing the iridium points can now be cut off with a cold chisel and treated as follows: The gold can be dissolved in *aqua regia*—composed of two parts of muriatic acid to one of nitric acid; after the gold is dissolved the acid can be poured from the points (now visible and separated); to the gold solution add oxalic acid crystals until the brown deposit ceases; this brown deposit is pure gold and can be melted into a button with a blow pipe, using carbonate of potash as a flux.

#### Up and Down Indicator of the Mainspring.

M. AMEDEVILLE VALLET, says C. SAUNIER in the *Revue Chronométrique*, one of our deserving watchmakers of Bordeaux, lately sent to us a specimen of his new indicator to show the tension of the mainspring. It differs from that of Mr. Barthet in two particulars: 1. It is more simple; and, second, it utilizes the motions of the stop-work.

The following is the history that prompted the invention: A marine officer, who owned a fine watch, was constantly in doubt whether he had wound it or not. He inquired of M. Vallet whether a contrivance could be introduced that would indicate the state of

the spring's tension. The artisan went to work and devised the following:

He fastened a border upon the plate, to raise the dial, whereby the center rim of the case had to be made broader. Beside this, a hole was drilled through the dial, in the prolongation of the barrel.

After the parts had been prepared in this manner, he disposed the mechanism in the following manner:

The barrel cover *B B*, furnished with the ordinary stop-work (male and female stops), bears upon the female stop, firmly united with it and retained by the same screw, a toothed wheel *a*. Another wheel *b* depths into this wheel, similar to the minute canon. This wheel *b* revolves freely upon a pivot fixed in the barrel axis, and with gentle friction upon the male stop.

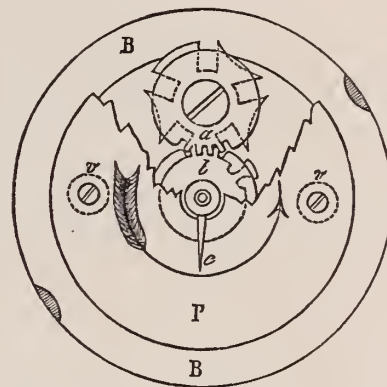

Over the whole is fixed to the barrel cover, upon two studs, shown in the dotted circles, by the screws *v v*, a disc *v P v*, perforated in the center to admit the canon of the wheel *b*. (This disc, which is supported upon the screw of the female stop, is broken away to exhibit the action of the pieces placed underneath).

The arrow, exhibited in the design, being traced upon the disc *v P v*, and a hand *c*, having been fitted upon the wheel canon *b*, it will at once be seen that as soon as the watch is wound the hand *c* of the wheel *b* will move toward the point of the arrow, and that when the axis has become immovable the barrel will move the hand *c* of the wheel *b* by means of the wheel *a* firmly united with the female stop, and move it toward the plumed end of the arrow.

This return motion is accomplished by divisions: The first must respond to the point of the arrow; the second to the base of its triangle; the third to the middle of the round and smooth arrow shaft; the fourth to the first plumes; and the fifth to the last; and, finally, the sixth (the spring is almost run down) to that position when the hand *c* stands at the extreme end of the arrow rod, which follows immediately after the plumed end (it has been forgotten by the engraver).

[It appears to us that a simple division in figures would be easier understood].

It is evident that before the arrow is drawn upon the disc *v P v*, to set the arrangement into motion, experiments must be instituted to establish the single points of the division.

#### The French Crown Jewels.

A EUROPEAN exchange—the *Gaulois*—contains some very interesting reminiscences, written by a French lady, who signs herself "Damed'Atours," prompted by the approaching sale of the French crown jewels. This time, it appears, they will be sold without reserve; although they were several times advertised to be sold, yet the dread that some plebeian democratic American—*ces sans culotte*—with more money than forefathers might be the purchaser, each time prevented them from being brought under the hammer; but times, especially in France, are hard, and money must be gotten somewhere, *cout qu'il cout*. But to return to the jewels.

The seven historical stones which were among the first diamonds

cut, and which were bought in Italy by Cardinal Mazarin whose name they still bear, formed part of the regalia in the reign of Louis XV. The collective value of these seven diamonds is estimated at \$1,300,000, but one of the seven is to be retained by the government, and this will considerably diminish the value of the six others. The only crown diamonds which Queen Marie Antoinette wore were the large acorn-shaped stones which she could arrange either as bracelets, necklaces or stomacher. She had some magnificent aigrettes and clasps, and a great many brooches for looping up her dresses, and diamond sprays; but these, like the splendid ear rings which she always wore, were her own property, and the greater portion was handed down to the Duchesse of Angauleme, the remainder being distributed among her friends. She did not like the diadem, and generally wore on state occasions the small crown which is placed at the back of the head. The Empress Josephine had a great fondness for colored stones, being of opinion that diamonds darkened her complexion; and as many of the ceremonies during the Empire took place in the daytime, she wore chiefly sapphires and rubies, which latter she styled the set off of brunettes (*le fard des brunes*). She often wore a row of flat pearls over the forehead. The Empress Marie Louise, being very fair, did not mind wearing diamonds, and she was also fond of sapphires; the splendid diadem of sapphires with the small crown of the same stones which are included in the projected sale, belonged to her. The Duchesse d'Angauleme wore the diamonds bequeathed to her by Marie Antoinette; and the Duchesse de Berry, who was renowned for her fair hair and shapely arms, wore her finest jewels mounted either as combs or bracelets—not the large combs and heavy bracelets of the First Empire, but smaller and more tasteful articles. Queen Marie Amélie, wife of Louis Philippe, sometimes wore in the form of a necklace, pearls belonging to the regalia; but she more frequently wore the sapphires and diamonds handed down by the Panthièvre family. Each princess of the Orleans family received at her marriage a full set of diamonds—diadem, necklace, ear rings, bracelets and sprays for the corsage, and was expected to wear them when presented at the Tuileries, those of the Duchesse d'Aumall being specially remarkable. The Duchesse de Montpensier received a very fine set of emeralds from the Spanish Court, which are now the property of her daughter, the Comtesse de Paris, and a curious story is told about them. A short time after his marriage, the Duc de Montpensier gave a large ball at Vincennes, and as the hairdresser had not arranged them in the duchesse's coiffure to his, the Duke's, liking, he took her hair down and arranged them according to his fancy, while the guests who had arrived first, were waiting for their host and hostess. The Empress Eugénie wore the crown jewels more frequently than any of her predecessors, and she completed the unequalled set of pearls, which, with its four necklaces, can be used as a stomacher or to garnish a train. The Empress, who for a long time would not wear any ornaments which increased the height of the forehead, had a very handsome Russian diadem which looks comparatively low on the forehead made for her. This diadem reversed makes a very pretty necklace. The Empress gradually got to like the higher setting diadems, and one which in later years she frequently wore is that of diamonds and turquoises which is included in the sale. She sold a short time ago a diadem of emeralds and brilliants which were her own property, and the so-called pigeon's-egg necklace of pearls which was bought by the late Madame de Paiva. Among the other pieces of jewelry mounted by her order is a large quantity of vine leaves and currants set in diamonds and very delicately wrought. This also will be sold.

#### A Stem Winder of the Last Century.

MANY WATCHMAKERS think that the stem winding arrangement, such as is ordinarily used at the present day, is a modern invention; nevertheless, every day brings additional proofs that the idea is far older than we are willing to give it credit for.

In the accompanying cut we give an interesting sketch of a stem winder used in an English watch, which was placed in our hands by our colleague M. P. Garnier. This watch is marked: "Frederic Kehlhoff, London, by his majesty's patent," and is recorded at London for the patent, in 1764; it is constructed in the style of Louis XV., without fusee, pin escapement, center seconds, with stop.

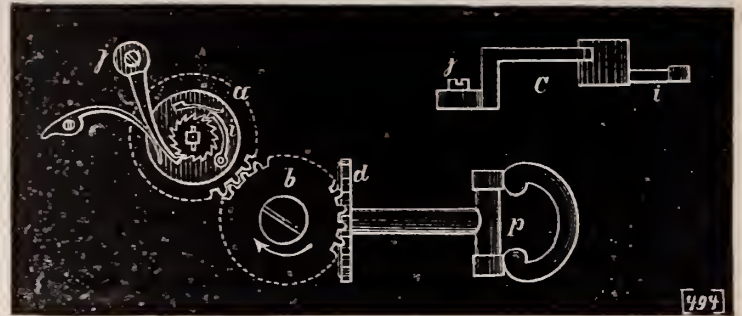

A single glance will inform the reader that by turning between the fingers the pendant *p* in an appropriate direction the wheel *d* will actuate the wheel *b*, which again causes to revolve wheel *a*, adjusted on the square of the barrel arbor. This last wheel, by its small click *i*, presses against a tooth of the ratchet, causes it to turn and winds the mainspring, while the large click *j*, whose center of motion is upon the plate, will prevent the ratchet from going back. At *C* is represented the development of the height proportions of the two clicks and ratchet. This part of the design shows that during the act of winding the watch the wheel *a* and its click pass under the large click at *C*.

When the watch has been wound the pendant is placed in a proper position by turning it in an opposite direction.—[C. SAUNIER, *Revue Chronométrique*.]

#### Rules of "Auld Lang Syne" for Owners of Watches.

[While hunting through our horological library we came across a French work, dated 1824, which contained the following set of rules to be observed by owners of watches]:

If the watchmaker is requested by a watch owner to furnish him with rules to be observed for the good care of his watch, let him do about as follows:

It is a main requirement for the preservation of the watch to always keep it clean. The dust is to be wiped off from the dial and out of the outer case, using a fine and clean linen or cotton handkerchief for the purpose, and from the corner and edges of the inner case rim it may be wiped away with a feather. Also for cleaning the key a feather is to be used; employ the plumed pointed end for the purpose or you may take a sharp piece of wood. Persons who are engaged in dusty or unclean avocations should not neglect to frequently clean their watches.

Dirt must never be permitted to collect to any excess in a watch nor must the oil be permitted to entirely dry up. When this happens the uniform rate is deteriorated, the pivots wear down, and the cylinders of cylinder watches wear out by the action of the scape wheel. It is advisable, therefore, to have a watch cleaned at least every three years and provided with new and good oil. Persons whose watch pocket is very hot must have their watches cleaned still more frequently because the oil dries quicker. This undue warmth may partly be guarded against by doubly lining the pocket. Inexperienced or ignorant persons in order to avoid paying the watchmaker for cleaning and repairing their timepiece often lubricate it themselves by supplying oil everywhere and in excessive quantities, as if they were greasing a door lock. This is decidedly injurious. Only the pivots and their holes must be lubricated, to be done with a small drop hanging to a fine wire as sharp as a needle.



Since humidity will cause metals to rust a watch should be kept as dry as possible. It should be opened only when required, least of all in dusty, smoky, damp places. Snuff takers should not take snuff when winding or opening their watch. \* \* \* \* It is well to wind the watch at the same hour every day, although this precaution is unnecessary when the fusee is truly made, since the watch must then go as correct in the first hour of its winding as in its last; it is but seldom, however, that we meet with a fusee so exact, and in the greater majority of cases we will find that the watch goes faster for the first hours than for the last. Such a watch can always be regulated in such a manner that the error will be compensated during the 24 hours; but if the watch were to be wound at different hours, then the compensation would no longer take place.

Neither is it advisable to wind the watch in very cold weather, because the mainspring snaps easily, nor should it be done on the street, so that no dust can enter, nor during walking, riding or driving, because the watch might be injured by the sudden jolts.

Many people believe that it is of advantage to let the spring run down at certain times so that it has the chance to stretch out and rest. This is a mistake. The spring cannot stretch out under these circumstances, and a watch that does not go is injured by reason of the rusting of the pivots and thickening of the oil. The rate of a watch that was not wound up for some time will always vary and must be regulated again. For these reasons it is also well to let a repeater strike sometimes to keep its repeating movement in order.

\* \* \* \* Many watchmakers will advise to keep the watch as near as possible in the same position, consequently a vertical one. According to others it is better to sometimes hang it up at night, and sometimes to keep it horizontal, changing sides; that is, at times with dial up and then again with dial down. If a watch hangs constantly there will be more wear on the lower sides of the pivot holes than at their end faces. If a watch is laid flat constantly, then the pivots will drill at their end faces and wear off visibly.

A watch must not be hung either on a window or a door that is continuously opened.

Its hands must never be moved with bare fingers but with the watch key which is to be placed upon the square of the canon pinion; it might happen that the hands are bent or broken with the fingers, beside this, the moisture of the latter would cause them to rust. It is not even advisable to turn the heads too often with the key, for instance, if it should have been forgotten to wind the watch, because the canon pinion becomes shaky thereby.

[And many other childish pieces of advice which a school boy of the present day would scoff at and consider insulting to his intelligence. We have learned various lessons since that time].

---

### Stage Diamonds.

[BY NYM CRINKLE.]

"Let me," said he, smilingly, "Rhea is going to have a dress of Spanish lace next season covered with the diamonds that she received from the Emperor of Russia, isn't she? She's going to wear it in her great role, eh?"

Such is the meagre but inflaming announcement that I have seen in the newspapers.

"Well," said he, "you ask Mr. Jimmy Morrissey to let you see the box that Mlle. Rhea's diamonds travel in when the campaign opens.

"Why the box? I don't want to see the box."

"Oh, yes you do. You want to look at it well and notice if it is made of mahogany, polished, with two heavy brass bands running round it with a crest engraved on them."

"And if I do notice all this?"

"Why then, you'll know that it's the regular old box and stock of diamonds that have been doing service for six or eight years. Let me see. The jewels started with Modjeska.

"See here," said he, seeing that I looked incredulous, "you don't mean to tell me that you are not up to the diamond dodge? Sit down there and I'll tell you something about it.

"In the first place, there are only two women familiar to American audiences who have got real diamonds enough to make an exhibition. One of them is Mme. Patti, the other is Mme. Janauschek, and they never do exhibit them.

"By the way, speaking of Janauschek, I see that the announcements of Ristori's coming are supplemented in one or two of the dramatic paragraphs with the additional intelligence that she is the greatest histrionic artist America has ever seen. That sounds very much as if America had never seen Rachel and hadn't got Janauschek yet. I wish you'd do me the favor to say that in my opinion Ristori never was and never will be as great an artist as Janauschek. She hasn't got the versatility, the emotion, the intensity or the power of Janauschek. Why, they played simultaneously here in 1866 and in the same roles, and if you go back to the criticisms of the *World* you will find that Janauschek walked away with the honors. Certainly nobody supposes that Ristori could play Hortense or Brunhilde, and after seeing Janauschek play Mr. Edwin Booth into the wings with her Lady Macbeth I don't think Ristori's artificial handling of that role would amount to much. But that isn't what I was going to tell you."

"No, it isn't! It was something about a mahogany box."

"Yes. Well, when Mr. H. J. Sargent started in the Modjeska season he had a countess on his hands who, so far as the theatrical business was concerned, was destitute of diamonds.

"She had some very fine jewels, as became a Polish nobleman's wife, but she wasn't going to have them trotted out. This annoyed Sargent, who knew perfectly well that in the Mississippi Valley there was an unassailable conviction that any foreign actress who had not received at least two diamond necklaces from the Emperor of Russia couldn't amount to much.

"One day when he had just got into—Buffalo, I think it was, to play that night, he saw in a jeweler's window a very showy necklace of stage diamonds. He went in and found that it had been made for Mary Anderson to wear in Pauline and she had refused to take it because her directions had not been followed with regard to the setting. 'How much do you want for it?' asked Sargent. 'Forty dollars,' said the jeweler. 'Give you thirty-five,' said Sargent. Then they compromised on thirty-seven.

"'Now, I want a box,' says the manager, and after running all over the town he got hold of a second-hand mahogany casket bound in brass. 'How long will it take you to polish this up and put two heavy handles on it?' he asked of the jeweler.

"'Have it done in an hour,' was the assurance of the obliging merchant.

In an hour Sargent was on his way to the theater with that box under his arm. He noticed with pensive care that the town had not thrilled much as yet under the flowing announcement that the Countess Bojenta would appear that night. Trade flowed on in its unbroken currents. Life was unperturbed. The great prosaic interests of the world did not appear to care whether Bojenta or Johannes had arrived.

"Mr. Sargent strode into the office of the theater. He was flushed and excited. 'Where's your safe?' he asked. They had not got any safe. He put the box down on the table and kept his hand on it. 'No safe!' he cried. 'What are you talking about? Do you know what's in that box? It's got jewelry in it worth \$50,000. I'm not going to take the responsibility of the thing any longer. Here, send to the police station. I must have a couple of men to watch it while I go to the bank.'

Then he got two officers to stay there and not take their eyes off the mahogany box, while he went off to the hotel and opened a bottle of wine. As he had shouted a good deal there was quite a group collected round the office. And in less than half an hour the Bojenta current began to stir along the sluggish street. He let it

work. When the two policemen were relieved the entire force knew of the Emperor of Russia's gift, and before 6 o'clock they had quadrupled the rumor by means of wives and sisters and sweet-hearts. At 8 o'clock there was only one person in that city who had not heard of the Emperor of Russia's gift.

"That person was the Countess Bojenta.

"The mahogany box worked so well that Sargent began to look upon it as a sort of Aladdin's lamp, and he rubbed it up every day and got a new idea.

"The first inspiration was to have it stolen. Hitherto only the policemen had made obeisance to it. Now the telegraph and the night editors fell down. The wires flashed it through sixteen States. The Emperor's diamond necklace was gone. A heavy reward was offered. It must have cost Sargent something to hire detectives to work up the case. I believe the *Bellefountain Bugle* published the original despatch of condolence from the Emperor of Russia.

"When the sympathy for Modjeska had become national, and there was some likelihood of the emotional women of the country making up a fund to replace her diamonds, a rash reporter forced an entrance to her boudoir one day when Sargent's back was turned, and found that her distress at the unparalleled loss was altogether disproportionate to the circumstances.

"An infamous and suborned press then began to give way to ignoble doubts about the robbery, and the *Bellefountain Bugle* even printed an editorial throwing suspicion not only on the Emperor's gift but upon the Emperor himself.

"Sargent was equal to the emergency. He took two of the most versatile and copious pressmen into his confidence. He pledged them to secrecy, that being the shortest cut to publicity. 'Now,' he said, 'I have a confession to make. I was so afraid that the Countess's jewels would be stolen that I had an imitation set made just like them for show purposes, and it was the imitation set that was stolen. The real gems are here.'

"With that he unlocked the safe and got out the mahogany box.

"'Gentlemen,' he observed, as he unlocked the box, 'you can examine those jewels. You can see for yourself whether they are of the first water. I'll send for an expert if you wish it.'

"The versatile and copious drew themselves up with dignity, 'As if,' they said, 'we are not experts enough to tell real gems like those from stage jewels!'

"This dodge worked very well for a few days. A new crop of stories broke out about the Emperor's necklace. But the original syndicate of night editors and local reporters who had sworn to the real robbery felt aggrieved. A committee waited on Mr. Sargent. 'See here,' said the spokesman, 'as we understand this thing, you agreed to have the real necklace stolen, not an imitation one. It's an outrage on the public and the press. You're a fraud.'

"'Go slow, my dear fellows,' said Sargent. 'I don't think you've got the thing right. If you will not give me away, I'll tell you. The fact is, I set that story going about the bogus necklace having been stolen, in hopes that it would reach the thieves and make them send back the real one. Of course, you saw the real necklace two months ago, and would know it if you saw it again.'

"The committee remarked that they should smile.

"'Very well,' said Sargent; 'here's the only necklace I've got now.'

"Then out came the mahogany box.

"'If you think that that is the genuine article, all I've got to say is, you are not up in stage jewels. If you'd like one of those pieces of glass as a souvenir, just pull it off.'

"The American press was pretty equally divided by this time on the question of the diamond necklace, and the American managers were getting to have a superstitious regard for Sargent and his box.

"But Sargent had got enough of it and he sold out the scheme to some other manager.

"I think it was six or eight months afterwards that Minnie Palmer lost her diamonds, and, meeting John Rodgers one day, he

began to tell me about it. 'The first thing the thieves took was a diamond necklace,' said he. 'But they left the casket.'

"Then out came the mahogany box.

"'John,' said I, 'I've seen that box before.'

"'Oh, well,' said he, 'I don't mind telling you privately that I had this made for show purposes'—

"John never got any further. We looked in each other's eyes and a dead silence reigned.

"Well, a year after, Kate Putnam began to be celebrated for her diamonds. I don't remember whether it was the Emperor of Russia or of Hayti who gave her a diamond necklace, but there was a great deal of anxiety observable in the press and the community for fear she'd be robbed; and Barron told me himself that the responsibility of it was undermining his health.

"'Let me see it,' I said.

"Then, by Jove, out came that mahogany box!

"'Never mind,' I said; 'you needn't open it. I've seen the necklace. The Emperor of Russia showed it to me before he presented it.'

"That ended Putnam.

"Well, the next one was Aimee. I suppose you know that Aimee at her last season in America, found it necessary to supplement her voice with a few diamond necklaces. I suppose Aimee had more Kohinoors than an Indian princess, and Grau asked me in one day to hear about it. 'Would you like to see some of the gems?'

"'Yes,' I said.

"By the eternal stones of Venice—out came that infernal mahogany box!

"'Look here, Grau,' said I, 'I can stand almost anything, but there's one thing that makes a fiend incarnate of me—it's a mahogany box. I'm surprised that you so far forget yourself.'

"He has never spoken to me since. Now, what I want you to do when you see Jimmy is to notice if the jewels that the Emperor of Russia gave Rhea are kept in a mahogany box, with two brass straps and a crest.'

"'I will.'"

---

### Superstitions Regarding Precious Stones.

A WRITER IN the July issue of the *London Jeweler and Metal Worker* contributes an interesting article relative to ancient and even modern superstitions regarding various precious stones. The writer had evidently ransacked numerous venerable authorities to obtain his information.

If any stone deserves worship for its beauty it is the opal; and, so rightly valued at its proper worth was the opal in olden days, that after ages admired the Roman senator who, when Marc Antony coveted his opal ring, went into voluntary exile, preferring to part with his country rather than his gem. Yet in these days there are numbers of people who will refuse the gift of an opal or sell any they may possess on account of its bad reputation as a bringer of bad luck and a dispeller of affection. Yet it was the reverse of an inauspicious stone in former days. According to Ohamakritus it was one of the stones that would insure the efficacy of prayer. According to Barquem the opal made the wearer lovable and conciliated love; it rejoiced the heart, preserved from poison and infection, dissipated melancholy and strengthened the sight. What, then, could be more desirable, either as a gift or a possession? Whence, then, arose the bad reputation of the opal?

Barbot, in his *Treatise on Precious Stones*, says that it is evidently due to its connection with the legend of Robert the Devil, without explaining further, while sometimes it is traced to the opal in Sir Walter Scott's *Anne of Gierstein*. It will be remembered that, in the weird tale of Anne's grandfather, the Persian lady whom he married possessed a marvellous opal, which, on the day of the christening of their child, when some holy water came in contact with it, first shot

out a brilliant spark, and was in the next instant "lightless and colorless as a common pebble." The Persian heroine fainted and died and was followed by her husband, Herman of Arnheim, three years afterward; and their granddaughter, referring to their history, said that she had heard of the opal growing pale, it being the nature of that noble stone to do so on the approach of poison, and Hermoine having been thought to have been poisoned by the jealous Baroness Steinfeld.

But it is evident that there is not enough in either of these tales to account for a total change of popular superstition, neither the legend of Robert the Devil nor of the Persian Hermoine having ever been sufficiently known to have had the slightest influence on common opinion. Till, therefore, some better explanation can be thought of, the wrong that is at present done to that fairest of all gems, the opal, must be set down as one of those freaks of superstition which is without justification or reason. But the superstition that yet lingers about the precious stones represents, happily, a fast diminishing quantity.

Who would think now of attributing to each stone a special influence over each month, and wearing, therefore, the sapphire in April, the agate in May, and so forth? Yet our ancestors did this, and even appropriated to twelve kinds of precious stones the twelve signs of the zodiac and the twelve apostles. Perhaps there was some pious intent in making the jasper the symbol of Saint Peter, the cysolite of Saint Matthew, or the uncertain beryl of the disbelieving Saint Thomas; but the modern spirit needs not these reminders, and their value at any time must have been very doubtful. But, smile as we may at the superstition that ruled in bygone times with regard to precious stones, we have to admit that it was not altogether without its brighter side. In the Dark Ages, for instance, it can have been no mean happiness to possess gems which, like the sapphire, ensured the fulfilment of prayer, or, like the diamond and amethyst, reduced war to a safe and pleasant pastime. What charm have we wherewith to face the perils and misfortunes of life comparable to the faith in their talisman which supported our ancestors?

---

### Obituary.

---

MONROE MARX.

MONROE MARX, junior partner in the firm of Kossuth Marx & Co., died at El Paso, Texas, Aug. 13th, 1884, after a brief illness. Mr. Marx was born in Syracuse, New York, April 28th, 1858, and graduated at the High School in that city at the age of fifteen. He then entered the office of M. H. Barber, a prominent insurance agent in Syracuse, where he remained over two years, his intelligence and capacity soon making him a trusted and confidential employee in the business and winning for him substantial advancement. He subsequently came to New York to engage in business with his brothers and became one of their representatives among their retail customers, traveling extensively in the west and southwestern section of the country. He was especially ambitious and successful in developing trade in new territory. On his usual southwestern trip at this season of the year he was overtaken by the disease that resulted in his death.

On the first of January last he was admitted to the firm as junior partner but continued to travel for the house. A telegram received by his brothers announced his illness at El Paso, and one of the employees was at once started for that city to care for him. On his arrival at St. Louis he was met by a dispatch announcing the death of Mr. Marx. He was sick only thirty-six hours, the doctors pronouncing his disease inflammation of the brain. His body was brought immediately to Syracuse for interment, his funeral being attended by many personal friends and business associates.

Monroe Marx was a young man of great energy and enterprise,

intelligent, ambitious and possessed of rare executive ability. He was quiet and gentlemanly in his deportment at all times, made friends readily and maintained their friendship permanently. There was something especially winning in his manners that tended to convert mere business acquaintances into personal friends almost immediately. He was a man of sterling integrity, extremely conscientious, painstaking and careful in all his transactions. His loss is a serious one to the firm of which he was a member and will be deeply mourned by all who knew him.

He was a member of the Jewelers' League and the New York Jewelers' Club.

---

JOHN S. BIRCH.

Mr. John S. Birch, of the firm of John S. Birch & Co., of this city, died July 26, of Bright's disease. He was known to the trade as the inventor and manufacturer of Birch's Patent Self-Adjusting and Adjustable Watch Keys, an ingenious device that has been very popular, and which brought to its inventor excellent pecuniary returns. Mr. Birch commenced business in this city in 1847 as a wholesale dealer in paper and paper hangings. He subsequently engaged in the manufacture of sewing silk, having a factory at Newark. He was also in the commission business, dealing in China and East India goods, and at another time in Japanese silks. As a merchant he met with severe reverses and was forced to give up business. Then he tried his fortunes in real estate and stock operations, but met with no better success. Being possessed of an inventive turn of mind, he devised and patented the Self-Adjusting Watch Key, which proved to be a success from the first and laid the foundation for his future prosperity. He was led on to make other inventions in other lines of industry, several of which proved to be useful and were well received. The only other devices of his known to the trade were his self-adjusting wrenches and key rings. Mr. Birch was a man of good intelligence, of indefatigable industry and unconquerable perseverance; he was kind and pleasant in his dealings with others, generous and charitable, and commanded the respect of all who knew him. Mr. Birch was 56 years of age, and left a widow but no children.

---

### Aristarchius Plumbago's Bicycle Watch Movement.

*To the Editor of the Jewelers' Circular.*

Through the columns of THE CIRCULAR the world has already been made aware of some of the beauties and important features of the bicycle movement, invented and patented by me. That conception or inspiration was borne in upon my gigantic intellect, as I have heretofore explained, while I was in temporary retirement through the machinations of over-zealous friends, in an asylum for erratic geniuses who are afflicted with an inordinate craving for things spiritual—in short, in an inebriate asylum. My brain reeled with excitement when I saw, in my mental laboratory, that it was possible to make a watch that would keep perfect time and serve a variety of other useful purposes, with only two wheels, a big one and a little one. In an excess of philanthropic benevolence I hastened to place before your many thousand readers the particulars of this creation of my superabundant intellect, and there is where I made my mistake. While this movement presented itself clearly to my mental vision, and there was painted upon the tissues of my brain the glowing panorama of the benefits that would come to the human race—of which I am No. 1—through the introduction of the bicycle movement, that movement had yet to be put in practical form and there was the rub. When I was released from surveillance I hastened to Chicago, where I knew business enterprise and unemployed capital existed in about equal proportions, determined to enlist both in the production of the greatest invention the world ever saw. Alas! to what bitter disappointment was I doomed! Enterprise I found most

certainly in unlimited quantities, and unemployed capital I heard of but could not grapple with. Like the small pox or the fever and ague I never could come into its actual presence, but learned that it was "just across the way" or "right round the corner;" whenever I put out my hand to clutch it, it melted away into air, into thin air like the baseless fabric of a vision. In short, the capital I required to develop my invention fought shy of me. I pursued it day and night but like the will-o'-the-wisp it eluded me, and led me into the quagmires of abject poverty and prospective starvation. Several persons, reputed to possess large amounts of unemployed capital, listened attentively to my eloquent descriptions of the bicycle movement; they showed apathy at first, then interest, and as my eloquence warmed with the theme, betrayed eager excitement. At the conclusion of my description they invariably said, "Show it to me." When informed that it existed only in my brain, and that I relied upon them for the means with which to clothe the child of my inspiration with visible shape and marketable form, they turned from me with averted eyes, and I am confident that I heard them make some remark about "crank." I hastened to explain that it was not a crank movement that I contemplated but a bicycle movement, but I could not prevail upon them to listen.

But light shone in upon me finally, and, as I wrote you, I made arrangements with a company that was about to erect factories at Stoneville for the manufacture of watches and jewelry, and supposed that the anserine fowl was suspended at the proper elevation. How easy it is to be mistaken. The Stoneville Company was full of promise, and promises was all I could get out of them. Supposing I had untold wealth at my command, I levied pecuniary contributions upon my friends to obtain my daily sustenance, and I am still indebted to them for the sums advanced. The Stoneville Company had no bottom; it was a visionary speculation inaugurated for the purpose of booming the town and selling corner lots of which the company owned many; in fact, they owned nothing but corner lots—they all cornered on a swamp that had no bottom but yielded an abundant crop of bull frogs and fever and ague. Thus was I deceived. Oh! it was cruel that I, Aristarchius Plumbago, public benefactor and professional philanthropist, should be deceived and defrauded by these guileless barbarians of the boundless prairie. But so it was, and the bicycle movement is as yet an airy nothing, floating in the innermost recesses of the brain of its great inventor whose name it shall yet make famous throughout the world. I can wait. I can illy afford to do so, but so long as kind friends continue their weekly contributions I shall rest quietly content for the appearance of that combination of enterprise and unemployed capital so necessary to my success, and for which my soul yearneth even as the soul of that Scripture fellow yearned seven years and more for his best girl.

But you have noted, of course, the consternation caused in the watchmaking industry of this country by the simple announcement of my bicycle movement. The great combinations of monopolists who are engaged in the manufacture of movements saw the announcement of my invention and read therein their doom. Their hearts quaked and their intangible legs trembled beneath their incorporeal bodies. They saw that the time had come when the price of movements would be brought so low that they could not compete in their production; when good, trusty, reliable bicycle movements in every imaginable form, and under every possible device would flood the market and drive them to the wall; they felt that the time was upon them when bicycle movements would be as common as wooden toothpicks in a cheap restaurant, and that they would have no hand in supplying this popular demand or in reaping the profits therefrom. They saw themselves dwarfing into insignificance and pecuniary impecuniosity, while the name of Aristarchius Plumbago, the blessed public benefactor, should wave from the tallest pinnacle in the temple of fame! They became demoralized and conjured among themselves how they should dispose of their stocks of movements on hand and save themselves from bankruptcy and ruin. The first thing to

be done was to stop the production, so factories were ordered to be closed, ostensibly for a summer vacation and cleaning up, workmen were discharged, the hum of busy machinery ceased to resound through the land. The factories that were filled with thousands of employees and abundant life and activity were stricken as if with palsy; the doors were locked and the shutters were put up; the sign "to rent" has not yet appeared upon them, but it is only a question of time when it will.

The next thing for these bloated monopolistic incorporeal incorporations to do was to get rid of the movements they had accumulated in anticipation of a continued demand. So they "put up a job"—to speak in popular parlance—on the trade to induce dealers to buy extensively. Emissaries were sent out to visit the dealers in every section and give them a quiet and confidential "tip" to the effect that they had private information that there were immense foreign orders for movements rolling in upon the watch companies, and that these were so great that it would take months to fill them; that in consequence there would be a scarcity of movements in this country; that the companies had grown so jealous of each other about these foreign orders that they were determined to underbid each other, and consequently there would soon be a cut in prices. The emissaries advised every dealer to buy up all the movements possible as soon as there was a break in prices. With such wild and delusive statements did the manufacturers seek to beguile the unwary dealers. Then came the other part of the programme; one company cut the price of its movements and advertised the fact liberally; then another followed with a reduction in price, and then another and another, till finally all of them had cut prices to a tremendous extent hoping thereby to get back at least the first cost of the movements. And all this was the result of the simple announcement that I was about to introduce my cheap but wholly reliable bicycle movement. If such demoralization followed the mere announcement of this greatest of modern discoveries, what will be the result when the movements are actually in the market? Why, these monopolies who have tried to act the part of the dog in the manger will find themselves, instead of respectable mastiffs, nothing but little skunks under the barn. Their efforts to save themselves are frantic but useless. By their own acts have they killed themselves.

But I made a mistake in announcing the bicycle movement before I was prepared to produce them in great quantities, and so take advantage of the popular tide in their favor. I should have waited, but my indiscretion in this respect has taught me to appreciate the truth of the remark that Napoleon made to Bismarck at the battle of Waterloo, "to rock the cradle when it is empty is injurious to the child." I should have waited till the child had assumed material shape and form. I want capital. A few millions of dollars advanced for the production of the bicycle movements will make the fortunes of those who contribute it. I am open to propositions, and hope to receive them speedily. Although at present in needy circumstances, I will not part with the control of the business. With my practical knowledge of mechanics, and my enlarged business ideas, I alone am a fortune to any who engage with me, and in addition I am willing to put into the business my incomparable inventions, including the bicycle movement, which is destined to revolutionize the watchmaking industry of the whole world. I appeal to enterprise and unemployed capital to come forward; I will meet them half way, and will guarantee that there are millions upon millions of dollars to be made. Unfortunately I cannot show a model of the bicycle movement, for the reason that the model makers to whom I have applied have ungenerously insinuated that a deposit would be required before they would do any work on my account, and my supply of deposits was exhausted. But the idea is perfected, and it is all mine. In the seething furnace of my brain I see the perfected bicycle movement as distinct and tangible to me as though made of brass or other base metal. Oh! why should civilization be forced to stay its progress for the lack of a few million dollars. I have my suspicions that the great monopoly watch companies are intriguing for my downfall, but

Aristarchus Plumbago, the great public benefactor, will rise above them all in defiance of their malignant detraction. Can you not send me a capitalist? It is not necessary that the millions of dollars alluded to should all be advanced at once. I tell you confidentially that for the present I could get along with the paltry sum of \$10. Do you know of anyone who will pay \$10 in cash for a half interest in the bicycle movement? If you do, give me his address; he's my mutton.

Yours expectantly,

ARISTARCHUS PLUMBAGO.

P. S.—I have just made an important discovery which will add another laurel to the crown which must eventually adorn my massive alabaster brow. I have discovered that the bicycle movement can be made with one wheel and two holes instead of two wheels and one hole. This will, of course, lessen the cost of production, for the holes can be made in sections and cut off to the requisite lengths. The profits will be proportionately greater. Oh! where! Oh! where! is that coming capitalist with a ten dollar note?

ARISTARCHUS P.

P. S. No. 2.—It has just dawned upon me that possibly I can dispense with one of the holes, and will now concentrate my intellect to solve this problem. Five dollars would aid me wonderfully at this critical moment. A wink is as good as a nod to a blind horse.

ARISTARCHUS P.

### Coloring and Polishing Brass Articles.

**I**N ORDER to prevent the constant oxidizing of brass articles, agents have for a long time been experimented with to protect the surface of these articles against the influence of the atmosphere, and the following method has been proposed as the most suitable and practicable one:

If brass is left for some time in moist sand it assumes a very handsome brown color, which, if polished with a dry brush, remains constant, and requires no cleaning or polishing. A darker or lighter green color may also be imparted if a thin layer of verdigris is created upon the surface by means of dilute acids, which are to be left on until dry. The antique appearance imparted to the brass in this manner is very handsome, and more or less durable. But it is not always possible, for want of time, to do this with each article, and a more rapid method for effecting the ends is therefore necessary, and the simplest way to do it is to cover the brass with a coating of varnish.

All the necessary work is to be done before the bronzing, and the brass annealed, dipped in old or dilute nitric acid until the scales can be loosened from the surface, which is then treated with sand and water and dried. The next step is to produce the desired bronze. Although this word actually signifies a brown color, being derived from the Italian word "bronzine," or, in English, "burned brown," it is rather loosely applied in the trades at present, and applied to all colors.

*Brown*, of all shades, is produced by immersion in a solution of nitrate or chloride of iron, whereby the strength of the bath determines the depth of the color.

*Violet* shades are obtained by immersing in a solution of chloride of antimony.

*Olive green*, if the surface is blackened by means of a solution of iron and arsenic in muriatic acid; it is then polished with a plumbago brush, and, when warm, coated with a lacquer composed of 1 part varnish lacquer, 4 parts turmeric, and 1 part gamboge.

A *steel gray* color is precipitated upon brass by means of a weak boiling solution of arsenic chloride. And a

*Blue* by an attentive treatment with a strong sulphide of soda.

*Black* is much used for optical instruments, and is produced by painting with a platinum solution or with chloride of gold mixed with nitrate of tin. The Japanese bronze their brass by boiling it in a solution of sulphate of copper, alum and verdigris.

The success in the art of bronzing chiefly depends upon circumstances, for instance, the temperature of the alloy or solution, the proportions and qualities of the material used for alloying, the proper moment at which the article is to be withdrawn, its drying and a hundred other minutiae of attention and manipulation require a skill only taught by experience.

If the brass is to receive no artificial color, but simply to be protected against tarnishing and oxidizing, it is to be lacquered after having been thoroughly cleansed. In order to prepare the brass for this coating it must be dipped, after having been annealed, and, as aforesaid, rinsed and washed, dipped either for a moment in pure commercial nitric acid and then washed in clean water and dried in sawdust, or immersed in a pickle of equal parts of nitric acid and water, until covered with a white coating of the appearance of curdled milk, when the article is taken out, rinsed in clean water and dried in sawdust. In the first case the brass becomes lustrous, in the latter it becomes mat, which is generally improved by smoothing and polishing the prominent places. The article is then dipped for a moment in nitric acid as found in commerce, and containing a little crude cream of tartar in order to preserve the color up to the moment of lacquering, and finally dried in warm sawdust. When prepared in such a manner the article is taken in hand to be lacquered, for which purpose it is first to be heated upon a hot plate to be lacquered afterward. For this purpose is used a simple alcohol varnish, consisting of 1 ounce shellac dissolved in 1 pint alcohol. To this simple varnish are afterward to be added the coloring substances, such as sanders wood, dragon's blood and annatto, which increase the luster of the color. In order to moderate the shading of the color, turmeric, gamboge, saffron, cape aloes and gum sandal are added. The first colors make the lacquer reddish, the second yellowish, while the two, when mixed, give a nice orange.

A good pale lacquer consists of 3 parts aloes and 1 part turmeric, to 1 part of the simple varnish. A gold lacquer is obtained by adding 4 parts dragon's blood and 1 part turmeric, to 1 part of the simple varnish, while a red lacquer is produced from 32 parts annatto and 8 parts dragon's blood, to 1 part of the varnish.

Lacquers are subject to chemical change by heat and light and therefore must be kept in a dark place. The vessels in which they are stored are generally of glass or clay, and the brushes with which they are applied must be camel hair and have no metallic parts about them.

### Agates and the Agate Industry.

**S**COTLAND, according to Professor Ruskin, is "itself one magnificent mineralogical specimen," and probably there is no similar area of the earth's surface from which so many mineral species have been obtained. These include a goodly number of the so-called "precious stones," as the topaz, the garnet, and such forms of silica as the cairngorm, bloodstone, jasper and agate. Scotland is famed for its agates, better known as "Scotch pebbles," which, although small compared with those found elsewhere, are yet unequaled in the variety and beauty of their colors. To the mineralogist, agates have the further attraction of being to some extent enigmas as regards their mode of formation. Professor Ruskin, in his recent paper to the Mineralogical Society, stated that the question of the production and painting of a Scottish pebble had been more or less the occupation of his best wits ever since childhood, yet he had not solved the problem. His advice, however, to the rising generation of mineralogists, that "a quick eye, a candid mind and an earnest heart were all the microscopes and laboratories they needed," raises the suspicion that the Professor's methods were defective. In the days when quick eyes were unaided by microscopes and laboratories, rock crystal was regarded as petrified ice, and agates were esteemed as an infallible specific in many diseases. Agates are found in trap and other ancient volcanic rocks where they lie like almonds in a cake. Their presence there is explained in the

following manner: When those palæozoic traps were molten lavas they were more or less saturated with steam, as many modern lavas are; and the expansion of this imprisoned vapor in the still plastic rock produced cavities throughout its mass, just as the gas generated by fermentation in bread gives rise to a cellular structure in the previously solid dough. Subsequently water, holding more or less carbonic acid in solution, filtered through the cellular trap rock and gradually dissolved out its silica, and this siliceous liquid entering the cavities, there deposited its mineral matter until these got filled up. Thus it is believed agates have come to be in those ancient trap rocks. The main difficulty lies in understanding the mode of entrance of the silica into the cavity so as to produce the concentric layers so characteristic of the agate. These in some cases are so fine that 100 of them may be counted in the space of a quarter of an inch. Dr. Reusch has shown how the agate structure may be strikingly reproduced artificially. He took an irregularly shaped cavity and introduced into it a thin cream of plaster of Paris, which, after shaking round, he poured out, thus leaving a thin coating of the material lining the interior. This was repeated with different colored creams of plaster until the entire cavity was filled up, and on cutting through the nodule thus formed the concentric layers of different colored plasters exactly reproduced the appearance of a banded agate. It is difficult, however, to see how such a process of rinsing the cavity with a solution of silica could have been effected in nature. Until lately the favorite theory was that the silica made its way into the hollow by a special opening termed the "point of infiltration;" the only argument, apparently, in favor of this view being the fact that many agates when cut show a channel somewhat resembling the neck of a bottle through which the agate-forming material was supposed to have flowed. On this theory, however, it is impossible to understand how the layers of silica should have been deposited of equal thickness all over the interior of the cavity as in most cases they are. The more generally accepted theory now is, that the solution of silica passed everywhere through the porous walls of the cavity by what is known as *osmosis*, and was thus deposited equally over its interior. A residual water gathered in the cavity, and as the latter got filled up with siliceous deposit, this water was gradually forced out through the so-called "point of infiltration," which thus formed a means, not of entrance, but of exit. "The point of infiltration," says Dr. Heddle, in a recent number of *Nature*, "instead of being at once filled up as would result from the inflow of coagulable silica, is in reality the last point filled up, being truly the point of escape; indeed, it frequently is not altogether filled up, remaining an open tube." The colors in different agate bands are due to the presence of oxides of iron and manganese, and partly also, it is supposed, to differences in rate of deposition; but why silica should deposit itself in one layer as chalcedony and in another as jasper, while in a third it is amethystine quartz, are points that still await explanation.

Scottish pebbles are found chiefly at Kinnoul Hill, near Perth, on the shore near Montrose, at Dungleigh, and at Burn Aune, near Galston, Ayrshire; but whether they occur on the shore or in river gravels they have been all previously washed out of trap rocks. The pebbles, cut by Edinburgh lapidaries, are used in the manufacture of Scottish jewelry. The chief seat of the agate industry of the world, however, is at Oberstein, in Rhenish Bavaria, where it has been carried on for centuries. It arose there naturally enough owing to the presence in the volcanic rocks of the neighborhood of abundance of fine agates; but it has continued and extended long after those rocks have ceased to yield, or at least to be mined for, the raw material of the industry. The agate quarries of Oberstein were abandoned owing to the discovery, fully half a century ago, of a rich supply of those stones in the river gravels of Uruguay. Some German workers in agate, who had emigrated to that region, noticed the courtyard of a farmhouse paved with pebbles that reminded them of the agates of their native Oberstein. Specimens were accordingly sent home and cut, and the surmise proved correct. Since that time

there has been a regular export of agate nodules from Uruguay to Oberstein, where they have long formed the staple material used in the agate mills. These "Brazilian agates," as they are called, when brought to Germany, are arranged in lots and sold by auction, stones of ordinary quality bringing, it is said, not more usually than 15s. per cwt. "German agates" are thus for the most part South American stones cut and polished at Oberstein. The extent of the industry has greatly increased with this accession of fresh material, and a few years ago there were no fewer than 153 agate mills working 724 grindstones, and giving employment altogether to about 3,000 persons. Cheapness of labor and a plentiful supply of water power have had much to do with the continuance of this industry at Oberstein. The labor is both ill-paid and severe. "The agate-worker," says Professor Rudler, who some years ago visited the mines and mills, "lies upon a low wooden grinding-stool, specially constructed to fit to the chest and abdomen, leaving the limbs free; the hands are engaged in holding and grinding the agate, whilst the feet are firmly pressed against short stakes or blocks of wood screwed into the floor; the reaction enabling the grinder to press the agate with much force against the moving millstone. The friction thus produced causes the agate to glow with a beautiful phosphorescent light, and red carnelians under this treatment look, it is said, as if they were red-hot. The millstones are of red sandstone, measure five feet in diameter, and generally make three revolutions per second. The finer agates are sliced by means of steel wheels and diamond or emery powder, but the coarser stones are simply chipped into shape and ground. Afterwards they are polished on rotating cylinders of wood or lead covered with moistened tripoli."

The ingenuity of the agate worker is not confined merely to cutting, carving and polishing his material into all manner of shapes. He has also succeeded in varying its color by artificial means. The layers composing an agate differ considerably in porosity, those that are transparent, for example, being less porous than opaque layers. Some, indeed, seem to be altogether impervious at ordinary temperature and pressure; and agate workers both at Oberstein and in India have availed themselves of this peculiarity in applying their staining processes. A suitable agate, after being thoroughly dried, is immersed in a mixture of honey and water or in olive oil, and is kept thus for at least three days exposed to a moderate heat. It is then washed, dried and put into a vessel containing enough of sulphuric acid to cover it. The vessel is thereafter exposed to a gentle heat for a varying number of hours, when the porous layers are found to have become much darker in color. The reason of this is that these layers, having become saturated with the syrup or oil, are acted upon by the sulphuric acid, which decomposes the sugary or oily constituent and forms in its place a deposit of carbon. It is in this way that banded agate is converted into the onyx with its black and white layers, used in the production of cameos and intaglios. Exposure to strong sunlight was long ago found to give a reddish tint to gray-colored agates, and this suggested the burning of such stones so as to convert them into carnelians. At Oberstein, likely stones for this purpose are first dried thoroughly, then saturated in sulphuric acid, and afterwards exposed in an earthenware crucible to a red heat. They are allowed to cool slowly and are then seen to be of a bright red color. Not content with imitating the rarer natural varieties of agate, such as onyx and carnelian, German manufacturers have taken to staining agates blue and all sorts of colors unknown in the natural stones. Aniline dyes, as unnatural as they are fugitive, have also been lately used for agate staining. It is possible that the stones themselves may yet be artificially produced—indeed, according to King, ("Natural History of Gems"), a Florentine anatomist long ago accomplished the feat, although unfortunately, the secret died with him. He is said to have petrified human viscera into real agates. "In the hospital of S. Spirito may be inspected still by the incredulous," says King, "a table-top made up of hearts, lungs, livers, etc., thus agatised into one large slab—meet board for a banquet of vampires!" Organic remains in agates are not unknown, for Bowerbank states that in the moss-agates of Oberstein he has found microscopic organisms; and Dr. Heddle that he has found undoubted organic remains of considerable size in agates from Ayrshire and other localities.

## Foreign Gossip.

PROGRESSIVE CIVILIZATION.—At a European scientific meeting a young lady read a paper "On the Blastophone of the Newt." After recovering our breath, we pause to ask, is civilization a failure?

HOME ELECTRICAL EXHIBITION.—Persons desiring to participate should remember that the International Electrical Exhibition will open at Philadelphia on September 2, and close on October 11.

ANOTHER EMINENT MAN GONE.—The demise is announced of Mr. A. S. Braithwaite, who, in conjunction with Mr. Ericson, designed the "Novelty," the locomotive which competed so closely with Stephenson's "Rocket" at the memorable trial in 1829. Mr. Braithwaite had been settled in New Zealand for many years, and died there recently, aged eighty-three.

MORE DIAMONDS.—At Bingera, New South Wales, the discovery of a new diamond field has been reported, which promises to rival the Kimberley diamond deposit of South Africa. A considerable number of fine diamonds have been discovered within the last few months. It is soon time that some poet will remodel Byron's celebrated line, "Thick as the leaves in Villambrosa." We tried it, but not being a poet, made several failures and gave it up in disgust.

"CARRYING COAL TO NEWCASTLE."—In former years it was often said by way of ridicule, of a man who did a gratuitous work, that he was "carrying coal to Newcastle," which was then the center of the English coal trade. This is about to become the sober truth, for we read in our English exchanges that the ship *Port Jackson* recently arrived at Liverpool from Sydney, New South Wales, with a cargo of 3,100 tons of Australian cannel coal for the Liverpool Gas Company.

MEETING OF GEOLOGISTS.—The International Geological Congress which has not met since the Bologna gathering in 1881, will hold a session next autumn in Berlin. The venerable Dr. Von Dechen has been appointed honorary president, while Professor Beyrich is the president of the organizing committee, and Dr. Hauchecorne the secretary. The meeting will extend from September 25 to 30, and will be followed by geological excursions from October 1 to 5. Arrangements of a very liberal character are being made for the reception of foreigners.

SPANISH EXPOSITION IN BERLIN.—It appears that the Prussian and Spanish governments have organized a mutual self-admiration society. A permanent exhibition of Spanish crude products is to be opened in Berlin, and a like one of ready German products will be opened in Madrid, to facilitate commercial intercourse between the two countries. This clear piece of policy was executed by the German Crown Prince during his recent visit to "El Rey Don Alphonso" of Spain, and is calculated to open a large market to Germany; beside this a commercial treaty has been effected between the two countries in which Germany is the favored nation.

CASTELLANI COLLECTION.—Very high prices were obtained for several lots at the twenty-one days' sale of the Castellani collection at Rome; thirty of the most valuable articles having been withdrawn, and those sold realized about \$140,000. A vase found in the Santa Maria Church at Capua, painted in various colors, brought \$5,000; a Greek mirror from Corinth, with bronze frame and figures of Venus and Cupid, \$770; a small statuette of an Etruscan warrior, a trifle above four inches in height, \$705, and a Diana in terra cotta, of a period a little later than Phidias, \$1,400. The terra cottas which the late Signor Castellani had purchased in Asia Minor realized the highest prices ever known; a figure of Victory, holding a gilt crown and a bouquet of flowers, was sold for \$1,240, and a Venus recumbent, for \$1,200. A large shrine made in the shape of a house, decorated with Limoges enamel, of the thirteenth century, by Raphael Grimaldi, was bought for the South Kensington Museum, of England, for \$5,100.

THE EXHIBITION AT PESTH.—We mentioned several months ago that an exhibition of goldsmith's work would be opened at Pesth, Hungary. Messrs. Franz and Karl Pulsky are the originators and promoters of this exhibition, and they have spared neither money nor trouble to make it a success. The imperial court, spiritual magnates, and wealthy abbey, temporal princes and magnates all were implored and offered their treasure, to adorn the exposition with the costliest and rarest works in their possession. It is said that there are mountains of gold and jewels exhibited, the commercial value of which is enormous, apart from the historical, artistical, and imaginary value.

A REMARKABLE FEAT IN TELEGRAPHY.—An achievement in telegraphy is reported by *The Telegraphist*, whose representative recently paid a visit to the offices of the Indo-European Telegraph Company, in Old Broad street, London, and was put into communication with the clerk in charge at Emden. After a few signals the line was opened to Odessa, and afterwards to Teheran. At the suggestion of the operator at Teheran, Keerachee was called, and the signals still found clear and good. Keerachee opened the line to Agra, and Agra switched on the line to Calcutta, and to the surprise of all concerned, the Calcutta operator asked, "Are you really London?" The signals were excellent and the speed no less than twelve words a minute. The total length was 7,000 miles of wire.

DISCOVERY OF A PYRAMID IN SONORA.—Our Mexican correspondent says that four leagues from Magdalena a pyramid has been discovered in the primeval forest. It measures 4,350 feet at base and 750 feet in altitude, which would make it to be twice as high as the pyramid of Cheops. A highway winds round about it and leads to the apex. The outer walls are carefully erected from large granite blocks. At a short distance is a hill of the same height, the surface of which is honeycombed with dwelling rooms dug into the rock. Hundreds of small rooms from 5 to 15 feet broad and 10 to 15 feet long are carefully excavated in the mountain-rock; they are generally eight feet high, with an entrance, but no window. The walls are covered with hieroglyphs and phantastical figures, and many stone tools lie about. It is supposed that these dwellings were built by the Mayos, an Indian tribe still in existence there, although it is only a surmise.

GARFIELD'S MONUMENT.—Professor Lenz, of Nuremberg, has obtained the order from San Francisco to cast the monument of President Garfield for this city. The model, made by the sculptor Happersberger, a native American at the time in Munich, represents the President in a standing position, with bared head, ("in simple citizen's dress," the German paper adds, perhaps in wonder that a President of the U. S. is not dressed up in the pomp and circumstance of office). The hands are lightly folded over each other, and the left clasps a document. The statue is 3½ meters high, and will stand upon a base of the same height. Upon the steps of the base sits a mourning female figure with a star diadem; its right hand seizes the sword, while the left deposits a wreath. On the sides of the base are to be introduced trophies of war and the American eagle. On the front side, underneath a large star, stands in large letters "GARFIELD."

THE PRESENT LINE OF VISIBILITY.—Although there is, perhaps, much to be desired in the improvement of microscopic objectives, we may still consider our present state quite an advanced one. Although the present theoretical limit of visibility is fixed at 146,528 lines to the inch, we need not be deterred from attempting to pass this point. The limit which was accepted some years ago as the true one, although considerably lower, was quietly ignored, as the angular aperture in objectives increased. It is only a few years ago that the majority of microscopists refused to believe that *A pellucida* which has about 100,000 lines to the inch, could be resolved, and now it is the work of beginners to do so. But supposing 146,528 lines to be the limit, it is evident that the one-eighth or one-tenth objective with a one-half inch eye-piece, is of amply sufficient magnifying power to make the lines visible to the eye, and there is therefore no need of using more. It is a good rule to follow, under all circumstances, not to use a greater power than is necessary to comfortably do the required work.

## Workshop Notes.

**TO MAKE GREEN GOLD.**—To make green gold, melt together nineteen grains of pure gold and five grains of pure silver. The metal thus prepared has a beautiful green shade.

**GOLD TINGE.**—A bright gold tinge may be given to silver by steeping it for a suitable length of time in a weak solution of sulphuric acid and water, strongly impregnated with iron rust.

**TO REMOVE GOLD.**—Gold is taken from silver by spreading over it a paste composed of pulverized sal ammoniac with aquafortis, and heating it till the matter smokes and is nearly dry, when the gold may be separated by rubbing with a scratch brush.

**TO RECOVER GOLD FROM GILT METAL.**—Take a solution of borax water, apply to the gilt surface, and sprinkle over it some finely powdered sulphur; make the article red hot and quench it in water; then scrape off the gold and recover it by means of lead.

**HOW TO MELT ALUMINUM.**—To melt alumina use a black lead crucible. Drive the alumina foil into an iron cone much the same shape as the bottom of the crucible, place the alumina in the crucible and cover with crude soda and charcoal pulverized together. Heat slowly.

**TO MAKE ALUMINUM GOLD.**—To make aluminum gold or bronze melt 90 parts copper with soda and borax for a flux, then add ten parts aluminum (all by weight) a little at a time by putting small pieces in a split stick of hard wood and pushing down to the bottom of the crucible. This mixture is of the color of gold, tough and malleable, and does not tarnish.

**FACETIOUS GOLD.**—It is averred that the following recipes will produce alloys of metals so nearly resembling genuine gold as to almost baffle goldsmiths without a resort to thorough tests. Fuse together with saltpeter, sal ammoniac and powdered charcoal, 4 parts platinum,  $2\frac{1}{2}$  parts pure copper, 1 part pure zinc, 2 parts block tin, and  $1\frac{1}{2}$  parts pure lead. Another good recipe calls for 2 parts platinum, 1 part silver and 3 parts copper.

**SILVEROID.**—Silveroid is the trade name given to a new, close-grained, brilliant white alloy, regarding the composition of which little is known beyond the fact that cadmium enters into it. It is intended to take the place of the brass, bronze and gun metal classes of alloys, and if all turns out to be true which is spoken in its favor it will soon do so, especially in the manufacture of articles which must be strong and capable of taking a fine polish.

**THE DIVISIONS OF TROY WEIGHT.**—Standard gold is compounded of 440 grains of fine gold and 40 grains (Troy weight) to the ounce of alloy; therefore, when you judge how much gold a piece of work will take, compound it to the standard weight by the following directions: *Assay weight*—The weight of gold is a pound, which is divided into 12 ounces; each ounce into 24 karats, each karat into 4 grains, and lastly, each grain into 4 quarts; then you see the assay quarter grain is in reality  $1\frac{1}{4}$  grains Troy.

**OLD RECIPE FOR COLORING BRASS.**—The *Neuste Erfahrungen und Erfindungen* reproduces an old recipe for the production of various colors on brass, but which we re-produce as it may be new to many of our readers: Dissolve 60 grains of bi-trartrate of potash in a liter of water, to which add 30 grams of protochloride of tin dissolved in a fifth of a liter of water, heat to boiling and permit the resulting precipitate to settle. The clear liquid is now to be poured under constant stirring into a solution of 180 grams of hyposulphate of soda in  $\frac{1}{4}$  liter of water and again heated to boiling, during which operation a quantity of sulphur will be separated. The resulting clear solution is now ready for use, and gives to brass articles suspended in it or when applied on the metallic surface according to the length of the exposure or the amount of the application, a great variety of shades of color. First follows a light color, then all shades successively from red, dark blue, light blue and finally brown. The sulphide of copper produces similar effects.

**MELTING AND REFINING.**—In melting brass gold, urge the fire to a great heat and stir the metal with the long stem of a tobacco pipe to prevent honeycombing. If steel or iron filings get into gold while melting, throw in a piece of sandiver the size of a common nut; it will attract the iron or steel from the gold into the flux, or sublimate of mercury will destroy the iron or steel. To cause gold to roll well melt with a good heat, add a tablespoonful of sal ammoniac and charcoal, equal quantities, both pulverized; stir up well, put on the cover for two minutes and pour.

**ALUMINUM SILVER.**—It is devoutly to be hoped that some practical way for obtaining aluminum cheap will soon be devised as this metal contains property highly valuable for articles which of rights should be light in weight. Octants and sextants of this alloy have been received with great favor by practical navigators. Those parts of such instruments which, if made with other metals, would weigh 4 pounds, will, when made of the above alloy, only weigh 1 pound. An excellent alloy aluminum silver is prepared by smelting together 1 part of silver with 3 or 4 parts of aluminum.

**ACID COLOR FOR 14-KARAT GOLD.**—Saltpeter, 4 parts; salt, 2 parts; muriatic acid, 3 parts. Put the first two in the pot and heat strongly; add a little water; let boil up, and when it becomes a thin paste add the muriatic acid; stir up and put in the work, taking care to completely submerge it in the color; let it boil two minutes, add as much water as you did before muriatic acid, make it boil quickly again for two minutes, take out the work, boil in hot water, then in another pot of hot water to which a few drops of muriatic acid have been added, rinse in hot water and dry as above.

**SOLDERING SILVER.**—The best solder for general purposes to be employed in soldering silver, consists of 19 parts (by weight) of silver, 10 parts of brass and 1 part of copper, carefully smelted together and well incorporated. To use this for fine work it should be reduced to powder by filing; the borax should be rubbed up on a slate with water to the consistency of cream. This cream should then with a fine brush be applied to the surfaces intended to be joined, between which the powdered solder (or pellet) is placed, and the whole supported on a block of charcoal to concentrate the heat. In the hands of a skillful workman the work can be done with such accuracy as to require no scraping or filing, it being necessary only to remove the borax when the soldering is complete, by immersing in jewelers' pickle.

**CARE OF WATCHMAKERS' BRUSHES.**—Watchmakers' brushes are a constant accompaniment to the watch bench; nothing except pliers, screwdrivers and tweezers being in more constant use; and how few use them properly, or rather, how few keep them in proper use. A soft brush for rough work is quite useless, a hard one for fine work is ruinous, and a dirty brush of either kind is a nuisance. The methods adopted for cleaning them are nearly as varied as the workmen that use them, and there are some who never even make the attempt. Some clean the brush with dry bread; some lay a piece of tissue or other paper across the wide open bench vise, the sharp corners formed by the jaws taking off on the paper a little of the dirt; others vigorously brush a piece of clean cork; and one man we knew who used his knuckles for the same purpose. All these various methods are imperfect while some of them can be called slovenly. The only good way to clean a brush is with soap and water—warm water, if convenient, being preferable. Wet two brushes, soap them and then rub them together in plenty of water and the job is done. The only objection to this way is the delay by drying; but this need not be, for six brushes assorted will give you three clean ones to use while the other three are drying; and the workman who cannot afford half a dozen had best seek some more lucrative occupation. More damage to the appearance of the movement is done by injudicious brushing than by any other means. The watch may not be injured in its quality as a timepiece, but it grows prematurely old in looks by such severe treatment.—[*Revue Chrono.*



## Trade Gossip.

D. L. Van Moppes arrived from Europe in the *L'Amérique* on August 18.

The gold edge bracelets, manufactured by W. E. White & Co., are very popular and having a large sale.

The firm of Martins & Tissot was dissolved by mutual consent, on August 9. H. Tissot will continue the business.

We are pleased to inform the many friends of George N. Fenn that he has completely recovered from his recent severe illness.

Edward Dreyfus, of Levy, Dreyfus & Co., has just returned from a four months' sojourn in Europe with his health completely restored.

In order to accommodate Eastern trade, the Excelsior Sign Co. have arranged with Cross & Beguelin to attend to all orders for their signs.

Mr. Henry Horwitz has arranged to travel for S. Dessau, importer of diamonds, and will hereafter have full charge of his diamond department.

C. S. Raymond has recently opened an attractive store at Omaha, which he has filled with an elegant assortment of attractive and desirable goods.

M. A. Myers, of S. F. Myers & Co., returned from Europe in the *Austral*, on August 16th. While abroad, he purchased many novelties for the Fall season.

The firm of Chester & Cornwell, Silver Cliff, Colorado, has been dissolved by mutual consent; E. P. Chester retiring, L. F. Cornwell continuing the business.

Samuel Perry, of the firm of Perry Brothers, has withdrawn from that firm, and formed a co-partnership under the firm name of Perry & Mead, 102 State street, Chicago.

E. Ira Richards & Co. are getting out their usual line of novelties this season, and are prepared to supply dealers with almost everything necessary for them to carry in stock.

J. M. Morrow, for many years with the Illinois Watch Co., has been appointed agent of the Hampden Watch Co., and opened an office in the Bryant Building, corner Liberty and Nassau streets.

George W. Pearce is traveling for the F. B. Rogers Silver Ware and Cutlery Co., of Boston, and attending to the requirements of the trade in New York, Boston, Philadelphia, Baltimore and Washington.

There are evidently two Charles Cook's in the jewelry trade; the one with F. M. Whiting & Co., is not the one with J. B. Mathewson & Co., and the one with J. B. M. & Co. is not the one with F. M. W. & Co.

Lestie Clime, a clerk of the Kirby House, was arrested recently, charged with systematic robbery of the guests of the hotel. It is alleged that Clime has been robbing traveling salesmen, principally jewelers, for years.

The hair spring stud index is the name of a new tool introduced to the trade by Joseph P. Wathier & Co. It is highly endorsed by practical watchmakers as a valuable tool for the bench and a great saving in the matter of time.

Chas. C. Haensler, of this city, has introduced some very attractive novelties in jewel cases, in velvet, plush, morocco, alligator skin, etc. He manufactures, also, show-case and sample trays for the trade, to which attention is invited.

Mrs. Mackay, it is said, gives away \$150,000 in charity every year. Her benevolence recently led to a pathetic appeal from some Parisian whose daughter was about to be married for any old diamonds or rubies she could spare.

The old-established house of Leroy W. Fairchild present again in this number of THE CIRCULAR more examples of novelties for the Fall season. The line including match boxes, cigar-cutters, charms, etc., are made in their usual attractive designs, and cannot fail to become very popular in the trade.

Henry Abbott has discontinued the manufacture of watch dials, having sold that branch of his business to Mr. Wm. Kirkpatrick, who will continue the business at No. 305 Pearl street. Mr. Abbott will continue the manufacture of the now very popular stem-winding attachments, the same as heretofore.

Edward Keeler, who was recently found guilty of blowing open the safe in the jewelry establishment of Elden B. Hayden, at No. 205 Fulton street, Brooklyn, and removing its entire contents, valued at \$5,000, has been sentenced to five year's imprisonment in the King's County penitentiary.

There are all sorts of clocks, but a new invention is badly needed—it is one that, instead of striking at 11 P. M., will pick up a dilatory lover and fire him out the front door. A clock of this description would make a fortune for the inventor, as there are probably a million of American fathers who would buy one.

An escapement for timepieces has been patented by Mr. August W. Kientoff, of Dallas, Ore. This invention relates to balance wheel or pendulum escapements, and provides a novel construction and arrangement of parts, making an escapement which can also be applied to a common toothed escapement wheel.

A stop watch has been patented by Mr. Samuel C. Scott, of Brooklyn, N. Y. The invention consists in an adjustable hollow arbor, attached to or a part of the arm of the lever for operating the chronograph mechanism of a watch movement, the arbor to receive the square winding arbor of the watch, the shoulder of which winding arbor operates the said lever.

A stem-holding device for watches has been patented by Mr. George T. Baughman, of Bellefontaine, O. The invention consists mainly of a collet or ring within the pendant, through which the stem, having an inner shoulder, is permitted to turn freely, the collet having one or more screws or pins arranged to enter the hole or holes in the pendant in which the ends of the bows fit.

A drummer representing a Philadelphia house, called upon the trade in Brenham, Texas, a few days ago, claiming to be an exclusive wholesale dealer in first class watches and jewelry. After finding that business was very dull, and failing to sell to the jewelers, he took his samples to a first-class dry-goods store and tried to retail any of his goods at wholesale figures to private parties.

In the August number of THE CIRCULAR, we stated that we had been shown an enameled nickel case, wherein various colors were harmoniously blended in different designs. This case is now offered to the trade by Joseph Fahys & Co. They have also arranged with Giles Brothers & Co. to attach their anti-magnetic shield to their dust-proof watch cases, and now offer them to the trade.

A stem-winding watch has been patented by Mr. George F. Johnson, of Aurora, Ill. The invention consists in a novel construction and combination especially of the setting lever and locking bar, and spring controlling the latter, whereby the spring operates to hold the setting lever in position, both when drawn out and pressed in, and prevents it when closed from dropping, and by striking the cover of the watch case, interfering with the closing of the case.

A fashion writer states that a revival emanating from the highest quarters is that of the locket or pendant worn at the throat with open dresses—one of the few ornaments suitable and becoming to all ages. Nothing unites richness and simplicity more than a glittering diamond pendant or cross depending from a narrow velvet neckband and worn with a clinging trained evening dress of pure white lace or tulle. One in black is equally effective.

A device for protecting balance wheels of watches has been patented by Mr. Everton J. Arrick, of McConnellsville, Ga. This invention is mainly designed for use in watch repairing, and consists in a flanged holder for balance wheels, which will admit of necessary work or repair without removing the staff from the wheel, and of the wheel being chucked in the lathe at either end of the staff, free from all risk of damage to the rim of the wheel while in the lathe.

The firm of A. Luthy & Co. have patented and introduced to the trade a new and handsome ornament for jewelry, in the way of a self-locking pin mounted in many unique designs, and styled the Claustra. The pin is on the principle of a jersey, having a stylish ornament on one end and a tip of neat design on the other, covering the point of the pin and at the same time locking it securely. The self-locking pin is susceptible of innumerable applications in jewelry.

A piece of work of unparalleled patience and ingenuity is reported from Karthaus in Bohemia, the wonderful workman being a youth in durance for five years for theft. He has turned his enforced leisure to use and manufactured a straw watch five centimetres in diameter by two in thickness. The works comprise a few bits of straw, some cotton, two needles and a pin, a small piece of paper forming a dial. It is said to go for six hours, and could be made to go twelve with a few improvements.

Messrs. L. Straus & Sons are sole agents in the United States for the New York & Rudolstadt Pottery Co., the largest factory devoted to the manufacture of bisque figures in the world. This factory, we are informed, employs a large corps of modellers, and by this means they are enabled to produce novelties in bisque figures and flowered goods and kindred art articles, in accordance with the demands of the market. Among their latest productions is the old Derby Decor, which is well known to lovers of art.

The new firm of Smith, Lesquereux & Co., manufacturers and dealers in optical goods, have appointed L. C. Fairchild & Co. as their New York agents. H. C. Lesquereux and W. H. Hurlburt have been for many years associated with the Burbank Manufacturing Company, and the new firm having bought the plant of the old company, they are identified with it in the same capacities as in the Burbank Company. They are live, energetic men who will push the business with characteristic vim, while Mr. Fairchild will second them with his usual ability.

Among the bone ornaments preserved in the Guildhall Museum, London, an armlet has lately been discovered engraved with incised Runic decorations. It was found in May, 1870, in Martins-le-Grand, and is said by the Scandinavian specialist, who detected it among the other specimens, to be unique of its kind. It has, in consequence, been placed separately in a glass case, above the Danish Runic Stone found in St. Paul's churchyard in 1852, to which it forms a fitting companion. Although Roman, Saxon, and even British remains are frequently met with in underground London, the relics of the Danish occupation of London are of very rare occurrence.

In our July number attention was directed to the operations of a person who sometimes goes by the name of C. B. Thompson, and hails from Bridgewater, Conn. He is in the habit of sending orders for goods to the trade, and when the goods are sent it is found exceedingly difficult to receive payment from Mr. Thompson. He recently wrote to John Frick & Co., ordering some goods, but Mr. Frick happened to recollect a transaction he had with a person of that name some time before, and instead of sending the goods, wrote him a letter recalling their former correspondence and suggesting that if he was the same individual, a remittance on account of "back dues" would be in order before he sent any more goods to the individual bearing the name of C. B. Thompson (without a "p").

The clock in Trinity Church tower in this city is the heaviest in America. The frame stands nine feet long, five feet high and three feet wide. The main wheels are thirty inches in diameter. There are three wheels in the time train, and three each in the strike and the chime. The winding wheels are formed of solid castings thirty inches in diameter and two inches thick, and are driven by a "pinion and arbor." On this arbor is placed a jack, or another wheel, pinion and crank, and it takes 850 turns of this crank to wind each weight up. It requires 700 feet of three-inch rope for the three cords, and over an hour for two men to wind the clock. The pendulum is eighteen feet long, and oscillates twenty-five times per minute. The dials are eight feet in diameter, although they look little more than half that size from Broadway. The three weights are about eight hundred, twelve hundred, and fifteen hundred pounds respectively. A large box is placed at the bottom of the well, that holds about a bale of cotton waste, so that if a chord should break the cotton would check the concussion.

Fred. A. Fiedler, the jeweler, Milton, Pa., has purchased an old, useful, ornamental and novel relic, in the form of a "Grandfather's Clock," evidently over one hundred years old. Matthias Fiedler, of Germany, is the maker. It is cased in very fine mahogany, and is nine feet high, twenty-seven inches wide at the top, and twenty-two inches wide by eighteen inches deep at the bottom. The movement is made entirely of brass and steel, and is a correct time keeper. In addition it denotes the day of the month. One of the most striking features of this clock is an oil painting above and at either side of the dial, representing William Tell, the Swiss patriot, making his escape from the boat as an Austrian prisoner, in the direction of Kiissnacht; he is in the attitude of leaping from a boat at "Tell's Rock" or "Leap." Above this handsome painting, in a triangular space, is the motto, "Hurrah for Liberty!" Just below, and on the right is represented the "Goddess of Liberty," being carried by the American eagle and shield in hand. On the left, Monarchy or Tyranny is represented by a king with a buckler in hand, and a lion at his feet. Between these representations of Tyranny and Liberty is the dial denoting the time of day and the day of the month.

How the hundredth part of a second is measured is told in the *Washington Post*. It says: "The chronograph, as its name implies, is a time-writer. Without it the division of time into the hundredth part of a second—a division so small that the mind can hardly appreciate it—would be impossible. It is a revolving cylinder, bearing a fountain pen attached to a magnet. As the pendulum of the clock swings its seconds, it sends the electric current to the magnet. The latter gives a nervous click, and the pen marks a small but distinct break on the paper. These breaks distinguish the seconds, and the space between them is measured by fine divisions on a slip of steel. A second in time, measured by space, is about as long as this: — — —."

The diamond beds of Bahia and Minas Geraes, in Brazil, are very similar in character, as regards the minerals composing them and their plateau form, or situation on water courses. A new bed has been recently opened on the Rio Pardo in Bahia, which presents some differences to those hitherto known in Brazil. The country around is low and marshy, and covered with forests. The working of these forests has led to the discovery of the diamonds, which are found in a white clay along with beds of decomposed leaves. The deposit appears of modern formation. The minerals of the clay accompanying the diamonds are, according to M. Gorceux, quartz, siliceous, monazite, zircon, disthene, staurolite, grenat almandine, corindon and some oxides of iron. There are no oxides of titanium, or tourmalines, as is frequently the case in diamond beds. The clay appears to be, from its character and situation, the debris of the granite mountains bordering on the Bahia coasts.

A curious point in diamond lore has just been established, to the delight of savants in Paris, where the exhibition of the crown jewels at the Louvre has made the subject very popular for the moment. It has long been laid down that the diamond has the power of retaining light, and of afterwards emitting it in the dark. The theory has been well buttressed by reasons; but the proof has not been easy of test. All, or nearly all, the great diamonds, such as the Kohinoor, the Regent, the Grand Mogul, cannot, for public reasons, be made the subject of experiment, and stones of a lesser size do not always give satisfactory results. Happily, a private individual, the owner of a gem of ninety-two karats, and estimated at a value of 300,000 f., has lent his diamond for scientific investigations. These have been most satisfactory, and the "phosphorescence" of the stone may be regarded as proved. The diamond was exposed for an hour to the direct action of the sun's rays and afterwards removed into a dark room. For more than twenty minutes afterwards it emitted a light, feeble indeed, but still sufficiently strong to make a sheet of white paper held near it quite visible in the dark. A similar result was arrived at by a very different experiment, and light was generated by rubbing the stone with a piece of hard flannel.

A pleasant event transpired in Providence recently, in the presentation of gold-headed ebony canes to George and Smith Owen, of the firm of G. & S. Owen & Co. The presentation was made to celebrate the fiftieth anniversary of the day when the Brothers associated themselves together in the jewelry business, and the fact that for fifty years they have conducted business harmoniously together. The canes were presented by their partners and bore the following inscriptions: "Presented to George and Smith Owen, from their partners, James P. Snow and Charles E. Westcott, as tokens of their high esteem and to commemorate the fiftieth anniversary of their establishment in business. 1834-1884." George and Smith Owen were born in Gloucester, R. I., the former in 1805 and the latter in 1809, and consequently they will be seventy-nine and seventy-five years of age respectively in September and November next. They subsequently removed to Providence, and George first learned his father's trade, subsequently entering the shop of Davis & Babbitt, jewelers, where he remained five or six years; while Smith learned the trade of jeweler and chaser of Mr. Joseph Veazie. Afterwards they became partners in the firm of Hunter, Owens & Co., but Mr. Hunter soon retired from the establishment and the business was continued under the firm name of G. & S. Owen. Later they admitted others to the firm, and the present members are Messrs. George Owen, Smith Owen, James P. Snow (admitted January 1st, 1872), and Charles E. Westcott (admitted January 1st, 1875). It is seldom in this country that business men are associated together for a term of half a century—exceeding, by considerable, the average business life of men—and should still continue in sufficiently good health to attend to business daily. A notable feature in connection with the firm is the extraordinary length of time some of their employees have remained with them, their terms of service varying from ten to forty years.



VOLUME XV.

NEW YORK, OCTOBER, 1884.

No. 9.

## THE JEWELERS' CIRCULAR AND HOROLOGICAL REVIEW

*The recognized organ of the Trade, and the official representative of the  
Jewelers' League.*

A Monthly Journal devoted to the interests of Watchmakers, Jewelers, Silversmiths, Electro-plate Manufacturers, and those engaged in the kindred branches of art industry.

### SUBSCRIPTION:

To All Parts of the United States and Canada,  
**\$2.00 Per Annum; Postage paid.**

To Great Britain, France, Switzerland, Germany, the West Indies, Mexico, the Republics of South America, and Australia, \$3.00 per annum. Postage paid.

*All communications should be addressed to THE JEWELERS' CIRCULAR PUBLISHING CO., 42 Nassau Street, New York.*

*Advertising rates made known on application.*

### The Circular—Its Future.

UPON THE death of our friend and leader, Mr. D. H. Hopkinson, in July last, the proprietorship of THE JEWELERS' CIRCULAR fell to his widow. Not feeling equal to the task of conducting the business herself, a company was formed under the title of THE JEWELERS' CIRCULAR PUBLISHING COMPANY, the object of which is to carry on the publication of this journal, and to issue from time to time such technical publications as may be deemed of interest to the trade or to any particular branch of it. Mrs. Hopkinson preserves a considerable interest in the company, while the direction of the business falls to the lot of gentlemen of proved experience and ability.

For the past sixteen years Mr. Hopkinson devoted the best of his life and thought—almost regardless of personal comfort and pecuniary outlay—to the firm establishment of this journal, and at his death its place was made, its connections were established and a trained corps of writers and business men were devoted to his service. Its policy was fixed, each department had its trained specialists. So well ordered and trained was this that the last three numbers have been regularly, and, we think, creditably issued while deprived of the assistance of the lamented chief.

The entire staff of contributors to the various literary departments of the paper who were associated with the late proprietor, and also every one of the gentlemen who aided him in the management of its business will continue in the service of the company. The publication of THE CIRCULAR will, therefore, be continued under substantially the same auspices as during the lifetime of Mr. Hopkinson.

A special technical magazine of this character necessarily requires the services of many writers, for no one man, however great his literary attainments and varied his study, can possibly be possessed of that technical knowledge that alone enables one to write intelligently upon the many branches of art that are comprised in the general

term, the jewelry trade. By way of illustration we may mention that in our columns there have appeared each month editorials upon current topics that engaged the attention of the trade; there have been special contributions upon silverware, upon ancient and modern art in jewelry, upon table ware, upon the manufacture of jewelry and almost every specialty in the trade, while "Excelsior," the well known practical horologist, has contributed many invaluable articles upon the subject of which he is the master. In addition, translators and technologists have made many important contributions to our columns. There are also the departments of "Trade Gossip," "Workshop Notes," "Foreign Gossip," etc., each of which requires careful editing. It will be seen then that a very considerable corps of writers and specialists has been at the service of THE CIRCULAR in the past, and, we are pleased to announce, will continue in the future as they have done to make this a thoroughly representative journal of the jewelry trade in all its branches.

While we are pleased to make this announcement as an assurance that THE CIRCULAR will maintain the high standard it has already achieved, we are sufficiently imbued with the progressive spirit of the age to induce us to enlarge the sphere of the journal's usefulness, and to make such improvements as will enable it to better serve the best interests of the trade. It is our intention that every branch of the business to which so many of the arts and sciences are tributary, shall have space devoted to it in our columns. Arrangements are already in progress having for their object the securing of special writers covering a wider range of topics than ever before; also for securing correspondents in the more prominent centers of trade who will keep our readers informed as to the current news of interest to them transpiring in these places. No sectional limitations shall hamper us, no local jealousies prejudice our utterances; THE CIRCULAR will recognize only the universality of the great industry it represents and champion every effort, wherever made, to enlarge its interests or better its condition. For many years this journal has maintained a high reputation for enterprise, fairness, independence and the taste and ability with which its contributors have treated the various technical subjects upon which they have written; a magazine so full of instruction should be in the hands of every person identified with the jewelry interest. It will be the special aim of the present managers to extend its circulation as much as possible, and thereby greatly increase its usefulness. The business of THE CIRCULAR imposed too large an amount of labor upon one man, and, in attempting to carry more than his share of the burden, the lamented founder of it undoubtedly shortened his life. This management will now be carried forward by several persons instead of one, but this new blood and this awakening and carrying out the new plan which the deceased designed executing we feel perfectly safe in promising that their enterprise and ability will make THE CIRCULAR more attractive and valuable than ever before, and of greater practical benefit to its many patrons.

In view of the fact that much interest, not to say anxiety, has been expressed in the trade as to the future of this journal, this much of an announcement regarding the future of the trade organ seemed proper.

### A Vicious Business Practice.

IT IS CUSTOMARY for a man in business to think, or at least to represent, that his is the worst line of business known, and that no other is so permeated with unbusinesslike and vicious practices. If he has opportunity, however, to look abroad among his neighbors and observe closely what they are doing, he will soon ascertain that his particular sphere of labor does not monopolize all the evils that afflict trade and commerce. In rare seasons of extraordinary prosperity, when everybody is overtaxed to fill orders, the evils of trade are comparatively few in number; but such seasons beget over-production and excessive competition, so that when the reaction comes, and stagnation takes the place of activity, merchants find themselves overstocked, and all sorts of means are resorted to in order to realize upon their stock on hand. Extraordinary inducements in the way of prices and credits are offered dealers in order to persuade them to select from the overstocked shelves, and every effort is made to shift this burden of over-production from one pair of shoulders to another. The manufacturer exhausts his eloquence upon the jobber and the jobber labors with the retail dealer. It is through over-production and too great competition that the evils so generally complained of have crept into our business methods. The jewelry trade is no greater sufferer by them than other mercantile lines of business, but they have become so pronounced that a reform in some of them seems to be a condition of future prosperity.

One of the worst of these evils is that of dating bills ahead, so as to surreptitiously give a creditor longer time on his purchases than is warranted by either the unwritten laws of business or proper regard for the creditor class. This practice has already worked serious disaster in the jewelry trade, and will do much more havoc unless put an end to. There are comparatively few houses that can afford to give such long credits as are secured by this means of dating bills ahead. They require all their capital in their business, and, to be successful, should be able to turn it over rapidly. When, however, what should be three and four months' credits are extended to six or eight months by this process of dating bills ahead, their capital is tied up and not available for current transactions. Let us illustrate: An out-of-town buyer comes here to make his purchases; if he is a retail dealer he goes to a jobber, but if a jobber he goes to a manufacturer, and agrees to buy goods provided his bill is dated ahead; suppose he buys on the 5th of September, his bill will be dated November 5, and he then gives a note at four months dated November 5; by this means he secures six months' credit with a four months' note, the seller losing the interest for two months. If the manufacturer or jobber does much of this business he will find himself soon loaded down with a lot of paper that he cannot negotiate. Most of the banks accommodate our business men by discounting their bills receivable when endorsed by the firm to whom they are drawn, but they cannot handle notes that are dated ahead and have not begun to run as against the maker. As a consequence those who require ready money are obliged to hawk their own paper through the streets or get note brokers to do it for them, and thus bring their credit under suspicion. When once afloat upon the sea of note discounting it is a hard matter to tell when to stop, and the victim is liable to go on till his outstanding notes are in excess of his visible assets. In short, he has resorted to that dangerous practice of over-certification that has brought so many banks to ruin. There is always the probability, too, that the debtor who has obtained six months' credit on a four months' note will want it renewed for four months longer, and in the end the seller finds that his bid of two months' credit without interest has resulted in tying up his capital for twelve or fourteen months.

This practice of dating ahead has grown to be very general in the jewelry trade, and is the result of too much competition. One firm makes this a bid to obtain custom, and is followed by the others who value present patronage more than true business principles. When once competition resorts to such unbusinesslike methods, there is no foretelling to what lengths it may not go. Credit is essential to the

prosperity of a country so new and so undeveloped, comparatively, as ours, but when credit is pushed beyond certain limitations it becomes dangerous. There is such a thing as too much credit and too great liberality in dispensing it. Many a man has been ruined and carried disaster to many besides himself, by having unlimited credit thrust upon him by over-zealous bidders for his patronage. It is a duty the creditor class owes to itself and to the public to see that credit, the keystone of business, is not abused. It is time to call a halt in this matter of promiscuous credits extended to unwarranted limits by the pernicious practice of dating bills ahead.

---

### The Business Outlook.

THE PRESENT business condition of the country presents some anomalies that are exceedingly difficult of explanation. Such of the crops as have been harvested have yielded most abundantly and all others promise to be equally prolific; everything necessary for the wants of the people exists in abundance, money is plentiful and all the conditions for general prosperity seem to be present. Yet the fact remains that for several months business has been exceedingly inactive; thousands of workmen in various lines of industry are lying idle, factories are operated on short time, and the "nimble sixpence" in trade has been extremely sluggish in its movements. Why this should be so is a problem political economists are striving in vain to solve. Abundant harvests are the best possible evidence that the country is rich, but producers seem disinclined to put this wealth, dug from our prolific soil, into circulation. The probable reason for this is the low prices that prevail for almost everything. The holders of our agricultural products, the producers themselves, are not inclined to part with their wealth at the prices offered. They have learned from previous experience to regard a bushel of wheat as worth to them a dollar, and they decline to sell when the price falls below that sum, as it has done this season; prices for other products are correspondingly low, and the farmers are holding on to their crops. Inactivity in the movement of the agricultural products of the country causes inactivity in all branches of productive industry, and, consequently, in all lines of business. But such a condition as at present exists is unnatural, and cannot long continue. A country having so much wealth in its agricultural productions, for which there is a reasonable demand, and having, also, an abundance of money with which to send these crops forward to supply the necessities of the world, should be at the height of business activity and commercial prosperity. Buyer and seller must eventually come together and agree upon an equitable price for this hoarded wealth in the hands of its producers, and when once the flood gates are opened and it begins to flow through the regular channels of commerce, a new impetus will be given to business of all kinds, and activity will usurp the place of stagnation.

In seeking for the moving cause of this deadlock between buyer and seller of the nation's products, we have but to turn our eyes to those great marts of trade, the Stock and Produce Exchanges, where speculation runs riot and gamblers hold the balance of power that controls business operations. By their wild and reckless dealings they have, within the past two years, reduced the market value of negotiable securities of various kinds by hundreds of millions of dollars in the aggregate; fortunes have been swept away in a few hours by this shrinkage of values, and the business community has been injured by so much as these annihilated values represented money that was invested in business. Add to the operations of the gamblers of the various exchanges, the dishonest transactions of a large number of trusted officers of financial institutions, and it is not to be wondered at that investors and the people have lost confidence and have called a halt in order that time may be secured to see where they stand. The prevailing spirit of gambling that seems to have seized upon almost every one is responsible for the hard

times of the past few months. This gambling is miscalled speculation, but it has no more the characteristics of legitimate business transactions than have the operations of the "faro dealer" or the "bunco steerer." The country is afflicted with "tickers" and "tape worms," that are to be found in almost all business houses, tempting their victims to risk their money in perilous ventures and eating away the substance of all who yield to their seductive influence. Every click of these pernicious machines sounds the knell that marks the financial death struggle of some victim. True and abiding prosperity will never come to our industrial and agricultural interests till this devil of speculation is driven out of the people. We have heretofore spoken strongly on this subject, and wish that every writer in the land would raise his voice in warning against it.

As a matter of course the jewelry trade suffers from the same conditions as other lines of business. Trade is dull, and it is folly to seek to disguise the fact. It would be useless for us to attempt to "bull" a "bear" market; the cry heard on every hand is in lamentation at the dullness of trade. There are more or less goods being sold, but the sales are not up to the anticipations of manufacturers and jobbers. Retail merchants are not buying extensively, and the orders of jobbers are governed by their prospective sales to the retail trade. All base their hopes upon the probable early movement of the crops, and their conversion into cash. Farmers cannot hold out forever against low prices, and when they once make up their minds that there will be no advance, or when buyers come to their terms, the money now lying idle will be brought into circulation, and trade will revive. As we have before said the condition is an anomalous one; the country teeming with wealth in its productions and also in money, and the two holding aloof from each other because speculative gambling has made them distrust each other. The demands of commerce will eventually break the deadlock, and business will resume its accustomed sway. This time is not far distant in the judgment of intelligent observers.

### Russian Art Work in Precious Metals.

THERE IS about to be added to the Metropolitan Museum of Art a most interesting collection of reproductions illustrative of ancient Russian art as applied to the precious metals. This collection consists of fac-simile reproductions of works of art that are treasured in the Kremlin at Moscow, and the Hermitage at St. Petersburg. Never before have the Russian authorities consented to have these works reproduced, but have jealously guarded them from the possibility of being copied by foreigners. When the Earl of Granville was prominent in the British Ministry, he used his influence, at the request of the Lords of the Committee on Education, to secure for them the privilege of copying for the Kensington Museum some of the works of art that are kept in the Russian art treasuries. After much trouble, he obtained the consent of the Emperor and the ecclesiastical authorities, and the result was that over three hundred pieces were reproduced by the electrolytic process. Three sets were made, one of which goes to the Kensington Museum, one to Cincinnati, while the third set was acquired by Mr. Henry G. Marquand, who presents it to the Metropolitan Museum of this city. The collection will be placed on exhibition in the course of a few weeks.

It is our privilege to present to the public a scholarly, illustrated description of this collection, prepared by Mr. John W. Miles, a gentleman well known for his artistic tastes, his love for the antique, and for his literary attainments. By permission of General di Cesnola, director of the museum, and of Mr. Marquand, the donor, Mr. Miles was enabled to make a careful study of this collection, and, as a result, he has prepared a description of it that will be treasured by all lovers of art. In this issue of THE JEWELERS' CIRCULAR will be found the first instalment of Mr. Miles' paper; it will run

through several numbers of our journal, and, when completed, will be the most finished and accurate description of these Russian reproductions that has been written. There will be several illustrations—some of them large and elaborate—with each instalment printed. It will be noted that we have copyrighted this article, which is done with the intention of publishing it in book form, in order that so valuable a document may be permanently preserved by those who are interested in art work of the character described.

### Gossip of the Month.

"FASHION is fickle" is an axiom so old and so trite that it is recognized as a truism. It may be added that fashion is queen in the jewelry business. Scarcely any other line of mercantile enterprise is subject to so many changes and fluctuations, brought about by the imperial mandates of this fickle queen, as the jewelry trade. Whatever she decrees is law and gospel to her devotees, and the jeweler is driven to his wits' end to keep pace with her demands. Jewelry that was all the rage one year is *passé* the next, and styles that were the fashion for a brief season must give way to new forms and designs. This is good for artists and designers, who are kept busy devising new styles, but it is rather hard on the manufacturer who is so often compelled to consign to the melting pot large quantities of goods that are out of date. But there is an old saying that fashions repeat themselves every seven years, so while the manufacturer may with profit melt over goods that are *passé*, he would do well to preserve his designs and his dies, for that fickle, coquette, fashion, may call them into service again. We will not vouch for the truth of the old saying referred to, but if fashions do not return every seven years they certainly do in time. A manufacturer recently remarked that "there is nothing new in the way of designs; the ancients covered the whole ground pretty much, and our most successful goods are reproductions of old designs, or are worked out of old combinations. As Shakespeare stole all the good things away from you 'literary fellers,' so those grand old goldsmiths of olden times left little for their successors to work out. The most profitable field of study for the designers of to-day is embraced in the art museums of the world, where examples of old gold and silver work are to be found. These combine exquisite beauty and splendid workmanship, offering opportunities for making beautiful combinations. Besides, ancient and classical designs in jewelry are in demand now, as it is the fashion, and fashion is the goddess whose slaves we are. Our American designers are full of originality in the production of special work to order, but these are not the taking goods in our ordinary mercantile transactions. We must make what the masses want, and not confine ourselves to the demands of the few who have artistic tastes and sufficient wealth to gratify them."

\* \*

\* \*

\* \*

SPEAKING of fashions, it was decreed some time ago that ladies should wear no gold jewelry, confining their personal decorations to precious stones. Those who could not afford these costly jewels eschewed jewelry—better to be without any ornaments than to plead poverty. This is the same principle that the man exhibited who refused to have his trousers mended, asserting that in the eyes of the multitude a hole might be the accident of a moment but a patch on his trousers indicated premeditated poverty. But the decree that banished gold jewelry has been revoked, and it is the fashion once more for ladies to appear in the street and the drawing-room with those golden articles of decoration that are so becoming. A modest brooch of classic design at the throat, with ear rings to match, are not only permitted in street and drawing-room costume, but are demanded by autocratic Dame Fashion; rings upon the fingers never

yielded their place entirely, and, even under the most rigorous dispensation were quietly tolerated; now they are fairly demanded; the watch, which was recently held in the belt by a ribbon matching the costume, may now be suspended from the neck by a "neat but not gaudy" gold chain, brought through at the front of the waist and holding the watch in the belt. In fact, gold jewelry is again the fashion with ladies; the dear creatures must have something to set off their many charms, and diamonds are too costly to be worn on every occasion. Besides, they offer too great a temptation to that numerous class of citizens who have no regard for that commandment which lays a positive prohibition upon stealing. Then, too, the ladies know that nothing calls attention to a pretty throat and neck or to their shell-like ears, like a bit of bright gold of some chaste and tasteful pattern. It was with feelings of deep regret that they laid aside, even for a brief period, these fascinating personal decorations, and now that they are once more permitted, our fair charmers have blossomed out fuller and sweeter than ever with their golden decorations. And well they may, for never before did they have such a rich variety to select from as is now temptingly spread out before them in the stores of the merchants. Our manufacturers apparently had a premonition of the demand that was to spring up—perhaps they have telephonic communication with Dame Fashion herself—and they have outdone themselves in producing new and attractive designs in gold goods, rich and sumptuous in their nature rather than large and showy. Well, let the ladies gratify their little vanity in personal decoration; it does them lots of good and injures no one. Then, too, the prettier they look the better we masculines like them.

\* \*

\* \*

\* \*

BUT WE masculines had better remove the beam from our own eyes before charging the ladies with vanity in the matter of personal decorations. Look at the ornaments fashion decrees us to wear: First, there is the inevitable and indispensable gold watch, sometimes two of them, the necessary gold chain with its pendant seal or locket, the scarf pin, the sleeve buttons (flop-overs), the collar and cuff buttons (also flop-overs), a possible diamond here or there, glove rings, with quaintly cut initials prominent, a tiny gold chain for the eye-glasses, or gold-bowed spectacles in place thereof, etc., etc. These for the average business man, but the possible lengths to which the "dude" may go in personal decoration no man can tell. Let him go; he needs much to make him tolerable. But, on the whole, the male specimen of the genus homo has little room for poking fun at his gentle sister on account of her desire to make her person attractive by the use of those numerous ornaments made ready for her by the goldsmiths. It is a question of fashion with both sexes, and it is difficult to decide which one is the more devout worshipper at the shrine of this changeable goddess.

\* \*

\* \*

\* \*

PASSING by the place of business of the New Haven Clock Company, in Park Place, a few days since, we noticed an oddity in the shape of a clock which had also attracted the attention of a number of passers-by. It is a small affair but difficult to describe. Outside of the case proper are two small, upright columns; projected from the top of the case is a straight piece which, for want of a better name, we may call a yard arm; suspended from the end of this by a thread is a small metallic ball; as the clock ticks this arm describes a half circle, throwing the suspended ball against the right hand column; then the thread winds around the column three or four times; then it unwinds itself; then it reverses the action and winds itself up again the other way; then it unwinds itself again, the yard arm is released, describes another half circle, comes slam bang against the left hand column, and there the little boomerang of a ball repeats the process of winding and unwinding around that col-

umn. Why it does it, nobody knows, but it does; and so that yard arm goes on describing half circles, slam banging and boomeranging first against one column and then another all day, and possibly all night. It is an eccentric contrivance and attracts scores of persons to the store. They say, too, that it keeps good time in spite of its proclivity to tangle itself up around lamp posts and other obstacles. By the way, the New Haven Company makes a most attractive display of clocks of all kinds, and the indications are that there is life and activity in that line of business at least.

\* \*

\* \*

\* \*

THIS gossip observes that there is a good deal of silver filigree work being worn now, especially by young ladies and misses. We are informed that large quantities of it are being sold to merchants from the interior where it has become very popular. There are some very handsome designs in this class of goods, while its gossamer-like appearance makes it very attractive.

\* \*

\* \*

\* \*

IN THE early days of September this vicinity was visited by a "heated term" of almost unprecedented length and severity. In the city the sun poured down its heated rays with prostrating intensity; the pavements almost glowing with fiery heat, while the solid walls of brick buildings that line the streets were charged with caloric to a degree that threatened immediate combustion, heating the little air that was stirring to an almost intolerable degree. Everybody that could do so fled to the mountains or the seaside, preferring to swelter and melt away in the open air, where there was plenty of room, to suffering cremation in the brick-bound city. Among those who flitted away were the members of the Horological Club, those venerable and expert horologists whose amiable discussions of technical questions have conveyed so much valuable information to our readers. The Chairman came down from the mountains for the express purpose of presiding at the monthly meeting; his costume consisted of a linen duster and two palm leaf fans. At the appointed hour he tapped the table with his gavel but none of his able associates appeared; of all that noble army he alone had courage to brave the dangers of the heated term. Perspiring at every pore, he gazed about him sadly; although nearly disintegrated by the heat, and almost emulating a late distinguished actor of Bowery fame, who used to advertise that he would "appear in several pieces," the Chairman decided that while there was a possibility of his being obliged to occupy all the chairs, there was not enough of him to constitute a quorum. So he adjourned himself for one month. The last seen of him he was evaporating in the direction of the Catskills on a cake of ice, his two palm leaf fans vainly striving to still further lower the temperature of his body.

\* \*

\* \*

\* \*

THERE IS nothing so good for trade as competition—except plenty of buyers and a flush money market. But competition should be confined to legitimate and honest limits. It is not legitimate competition when one seeks to build up his own business by tearing down that of another. Detraction and misrepresentation are not commendable business methods. Yet there are men in the trade and travelers on the road who are irresistibly impelled to discredit the productions of their competitors wherever they come in contact with them. If the goods show no fault in workmanship they invent them, inveigh against the quality of the gold in them and ridicule the style and design. These men seem to have been born with a chronic disposition to find fault; they would grumble if they were about to be hanged for persistent grumbling. A country dealer

recently caught one of these peripatetic fault-finders in his own trap. Before opening his own samples, the traveler looked over the stock in the dealer's show case, found fault with this thing and criticised that; wondered how this manufacturer dared to send out such goods and why the other one did not have some regard to styles. Presently he opened his own samples and began to extol the excellence of his goods. Then he and the dealer changed places, and the dealer became the grumbler and fault-finder. He criticised adversely everything shown him; he examined the workmanship with a magnifying glass and pointed out all sorts of defects; the styles were antediluvian and the designs were caricatures. For an hour the traveler listened while his goods were dissected and their imperfections distorted, till finally he became enraged and took his departure in haste, while the dealer quietly remarked as he chuckled to himself, "the adornment that suffices to decorate the anserine fowl of the female persuasion is a sufficient garniture for the male insect of the same species," which being translated into the vernacular implies that "what is sauce for the goose is sauce for the gander." Moral—detraction is a boomerang that is liable to re-act upon the proboscis of him who indulges in it.

\* \*

\* \*

\* \*

BUT commercial travelers are not, as a rule, given to making themselves obnoxious to their customers. On the contrary, they are, generally speaking, jovial, whole-souled, sharp, keen, wide-awake gentlemen, the trusted representatives of important interests, anxious to serve their customers and their employers fairly and honestly, and in as expeditious a manner as possible. The traveler is a sort of migratory shuttle-cock, batted about from pillar to post, always hurrying to catch a train and his mind filled with anxiety lest he should miss a connection. While preserving a calm and impassive exterior his soul is writhing in anguish lest the dilatoriness of his customer shall cause him to lose a train and so to miss his next day's appointments. He eats and sleeps as circumstances permit, never with regularity, and seldom satisfactorily; he is away from his family weeks at a time, and possibly, by missing his connections is also deprived of regular communication with them. His life is a hard one, and those whom he favors with calls should bear in mind the fact that to every commercial traveler "time is money." They are deserving of courteous and gentlemanly treatment at the hands of every customer. He may come down upon you at an inopportune moment when you do not desire any goods, or are, perhaps, especially busy; if so, it will take but a moment to state the facts courteously, and to show that while you recognize that he is a gentleman you are also one. We heard a traveler during the heated term indulging in some very heated language regarding a dealer on whom he had called, and who kept him waiting two hours before he would give him an audience. Meantime the dealer was in a back room getting his fishing tackle ready to go fishing next day (Sunday). As a consequence of the delay, the traveler was compelled to remain in that city over Sunday when he ought to have been in another place a hundred miles away. Politeness is indissolubly connected with the characteristics of a gentleman, and however much a gentleman may be annoyed, he never so far forgets himself as to be rude or boorish. Commercial travelers are an indispensable boon to the mercantile community, and, being gentlemen, are entitled to be treated with that respect and courtesy which make of business a pleasure.

\* \*

\* \*

\* \*

CASE makers complain of the demoralization that has fallen upon their business. This is not attributable especially to over-production but to unwise competition. Possibly if the production of cases could be suspended for a time the business would slough off its unbusinesslike methods, for when the demand for any class of

goods runs ahead of the supply they sell themselves, and it is not necessary to resort to unhealthy practices to get rid of them. But when supply and demand are evenly balanced, manufacturers become so afraid of being caught with a surplus stock that they cut prices, become reckless in their sales and so kill the goose that lays the golden egg. Prices for cases have become so demoralized that workmanship suffers, and the maker is fortunate if he can get back the price of the metal in his cases without any compensation for workmanship. In its present condition there is no profit in case making, and those in the business are complaining loudly of the situation. In many instances a reduction of prices means a degradation of quality; in regard to cases, various devices are resorted to by some makers to make their goods correspond to prices, and, by substituting base metal wherever possible to maintain the standard of weight, still making a saving on the precious metal employed. Steel is made to fill the space where the gold or silver is cut away, and heavy springs are introduced to compensate for the absence of the more valuable metals. So individual morals are corrupted in an effort to sell a dollar's value for seventy-five cents. It is singular that the good, practical, sensible men engaged in case making cannot come together and agree to abandon those unbusinesslike practices that are so injurious to them. It seems as though a little effort properly directed might so harmonize conflicting, or rather, competing elements as to do away with some of the evils complained of, and put the case making industry on a basis whereby those interested might fairly hope to get back at least a new dollar for every old one sent out. Half a dozen of the leading case makers might, by united action, revolutionize the trade in this respect.

\* \*

\* \*

\* \*

AN ENGLISH paper announces that the Scottish pearl seekers have met with unusual success this year, securing pearls in great numbers, some of which have been sold at high prices. Some of the rivers in the north of Scotland abound in pearl-bearing mussels, and this year has been unusually favorable to obtaining them, owing to the low stage of water in the rivers. As a consequence of these remarkably valuable "finds," the inhabitants along the banks of the river have abandoned their usual avocations and turned their attention to mussel hunting. It is feared that great injury has been inflicted upon the pearl industry of the future by the reckless destruction of mussels that has been caused by this rush of pearl seekers, who prosecute their work without regard to future production. A demand is made for some sort of legal protection for the incipient but possible pearl-bearing mussels.

\* \*

\* \*

\* \*

VERY elaborate and costly bric-à-brac cabinets adorn the residences of our wealthy citizens, but it is not alone the wealthy who delight in things of beauty and elegance. There are thousands of persons who cannot afford expensive cabinets who, nevertheless, derive pure and unalloyed happiness from the contemplation of a few valuable pieces of bric-à-brac of which they are the fortunate possessors. A lady friend of ours, who has a few choice pieces of old silverware, showing examples of rare workmanship, and some quaint specimens of ancient pottery (which, by the way, are to the modern eyes exceedingly ugly) has solved the difficulty of a cabinet without incurring the expense that lies in ebony cabinets elaborately carved. She has made some shelves of pine wood, and these she has covered with plush and hung on the walls or fitted into odd corners. On these she displays her treasures, and their artistic arrangement, the various cherished articles nestling in beds of soft plush, shows them to most excellent advantage. Heirlooms of old silver may be made to look very attractive in this manner, with a plush background to the shelves.

THERE were a good many buyers in the city last month from all sections of the country. Those that were here during the heated term were not in a humor to make purchases while the mercury was struggling among the nineties, and the heat was intense enough to blister the pavements, so they hied them to Coney Island, Long Branch, and other seaside places, where they were at least sure of spending a cool evening. It was a harvest time for summer resort landlords, without which their season's business would have been a failure. But the buyers turned up smiling when the "cold wave" reached here, and were all the more affable after their brief rest and recreation. Their purchases were only moderately liberal, but their orders were sufficient to wake up the street somewhat, and to give assurance that the fall trade will not be so bad as has been predicted. We do not claim to be the son of a prophet, nor the seventh son of a seventh son, but some months ago we ventured the prediction that when the trade has closed its books for the year, and the balance is struck, it will be found that the volume of business will show a fair average with that of the past five years, and this prediction we still adhere to. Perhaps the margin of profit may be reduced, but that is not our lookout; it is our business to do all we can to stimulate trade, and if the merchants do not make a fair profit on what comes to them, they cannot accuse us of having made their prices.

\* \*

\* \*

\* \*

DOING business for love is not a profitable operation, as the chain makers are beginning to find out. Like the case makers, the chain makers have been afflicted with unbusinesslike competition that has broken down prices till there is no profit in the business. At least, this is their complaint, and as it is general among them it is, no doubt, true. But who is to blame for this? We know that competitors in business always excuse themselves for cutting prices by saying: "Well, my rival did it first, and I had to follow him or lose my business." This never seemed to us a valid excuse for cutting prices so they would not cover the cost of production. When a man does that it is good policy to let him have the whole of the business—it will break him up all the sooner, and when he is gone the others can easily win back their customers. When a man finds that he cannot make a fair living profit on his productions, it is time he looked for other business, unless he is so infatuated with it and is so much of a philanthropist that he prefers to continue it for love. It is bad for all lines of business when any one industry fails to yield a fair and reasonable profit upon the capital, labor and ability invested in it. The country at large is never so strong and lusty as when all its business men are being adequately compensated for their labor and investments. The workmen are then properly rewarded and contentment reigns supreme. The chainmakers have made several efforts of late to organize for the purpose of correcting the abuses that exist in their business methods, but there is always a small minority who refuse to give in their allegiance to the organization, and the majority is afraid to go on and leave them on the outside. Every army has its corps of "bummers" and its bands of guerrillas, but while the army may be annoyed by their acts of brigandage, it moves right along upon its objective point, and swerves neither to the right nor left at the bidding of "bummers" or guerrillas. If the majority of the chain makers determine to organize to correct the evils that afflict their business, they are strong enough to carry out the measures they in their wisdom may determine upon. They can also carry the war into Africa, and force the guerrillas to lay down their arms and come into camp. Go for their business; retaliate; if necessary, undersell them with every customer they have, but maintain good faith with each other. There is a little story current that seems apropos to this advice. A young gentleman was walking out with his summer resort girl one evening, when suddenly she uttered a scream of terror, a look of horror settled

upon her features, and turning to her amazed companion, she exclaimed: "Run for help! Run for your life! Go quickly!" "What is the matter?" anxiously asked her companion. "Oh! hurry up! Go for some one, quick! There's a bug down my back!" shrieked the fair maiden. "Hadn't I better go for the bug!" murmured the sensible young man. The chain makers should ascertain what particular bug it is that is undermining their business and then "go for" that identical insect with all the energy they can command. The remedy is in their own hands, and it is useless to call on Jupiter for aid till they have first put their own shoulder to the wheel. In this country an honest majority, acting in good faith, can always win.

---

## Jewels and Jewelry.

*Continued from page 235.*

IN ORDER to give a proper idea of how jewelry is manufactured, probably the best way is to describe a large manufactory in Newark which I visited. In the basement are extensive store rooms for coal and coke; there are large rooms for the clothing of the male operatives, for they are required to change their clothing on entering the shop; and there are 2 rooms devoted to the saving of the immeasurably small particles of gold, which but for the closest scrutiny and care might be lost. In one of these rooms is a powerful grinding machine for reducing to dust all the sweepings, filings, the small pieces of gold detached from articles in process of manufacture, and all other waste solid substances collected from the work rooms from day to day. This is transferred to the amalgamator, a machine in which it is treated with mercury, to separate the gold as is done on a larger scale in mining. In another room is a series of filters through which is passed all the water from the sinks in which the employees wash at the close of each half day of labor, as also the water used for washing the towels and articles of clothing used only in the factory. Nothing is allowed to be taken from the building to be washed; the importance of this strict care is evinced by the fact that often the profits of a whole year's work consists in the value of these sweepings; there is a finishing room where all finished work is properly examined; in the vaults are stored the stock of metals, and on the same floor is the supply room where the metals are given out under a complete system, so that should an operator be inclined to dishonesty the temptation is precluded by the certainty of detection. In another room is the coloring room; in another the gold, silver and copper are melted and combined; for greater facility the metal is first granulated by melting and pouring slowly into water, the gold taking the form of small pieces of very irregular shape. There is a tool room where the dies are made and the remainder of the floor contains drop presses and rolling machines. The routine of work begins with melting and combining of metals, casting into ingots, subjecting it to powerful rolling machines, rolling it as fine as tissue paper if necessary. The next process, stamping, in which drop presses are used, develops the figure either in *repoussé* or relief, or gives the full outline and shape of the whole or part of any article, as a locket or the links of a chain. The various parts of a chain or other article are then put together with a rapidity which would astonish anybody not in the business. Engraving is the next operation. In articles in which the figure is wholly or in part of enamel, at first only the part of figure which is to be filled with enamel is engraved. This material, which has for its basis pure crystal glass or "frit," ground together with a fine oxide of lead and tin and variously colored by adding other substances, chiefly the oxides of different metals, is applied in the form of paste and then submitted to the action of heat, sufficient, without melting the gold, to form a close adherence between the enamel and the gold, and at the same time to vitrify the enamel so that it may have at once the hardness of crystal and its susceptibility to a high polish. The sur-



face of the enamel is then filed or ground down and the engraving of such parts of the figure as are not enameled is completed. The article is then polished and finished. In the manufacture of jewelry machinery supersedes hand labor to a less extent than in most other industries; used wherever desirable, it is rather to facilitate and supplement than to take the place of manual dexterity and skill. Automatic machinery is not used; at present  $\frac{9}{10}$  of all gold jewelry in the United States is manufactured in New York and Newark. Very little is imported, as American jewelry is superior in design to any other, and in solidity is probably only exceeded by English jewelry, whose patterns, however, are very inartistic and clumsy. The interior towns are supplied by means of commercial travelers who are continually scouring the country, carrying all their goods with them in values ranging from \$25,000 to \$100,000. So important has this industry become that every hotel contains a special safe for the accommodation of jewelry salesmen. In regard to the amount of jewelry manufactured annually in this country, no statistics are obtainable, but in 1880 the Director of the Mint endeavored to ascertain the amount of gold used in manufactories, and mailed circulars to every manufacturer in the United States requesting information as to the amount consumed, and although many failed to reply yet from returns received it appears that out of \$40,000,000 worth of gold and \$38,750,000 of silver taken out of the mines about \$5,500,000 worth of gold and \$500,000 worth of silver was consumed by jewelers. Taking the intrinsic value of the gold to be about  $\frac{1}{4}$  the value of the article when finished, we obtain a result of \$22,000,000 as the annual production of jewelry in the United States; adding 25 per cent. as the retail price we see that about \$30,000,000 are spent for gold jewelry alone not including precious stones. As fully 50 per cent. of this is spent by young men on their sweethearts in the shape of Christmas and betrothal presents, it will be seen how much it costs the American youth to love. If ice cream and theatre statistics could be added to this the result would be simply awful. It is the retail jewelry store which has a noble mission to perform in this world and the happiness of many a damsel is yearly owing to the jewelry salesman, who, by his eloquence and unselfish interest of her welfare, causes many a heartlessly economical lover to relax and invest a part of his savings to decorate his fair one who might otherwise have passed such a thing as jewelry in silent contempt. And so the cry of many a fair damsel is: "Long live the jewelry salesman."

As no paper on jewelry would be complete without a mention of the precious stones, I will pass briefly over the jewels used in its manufacture:

#### JEWELS.

To give a complete description of all the precious stones used in jewelry, together with their history, composition and characteristics would be an impossibility in the time allotted to me, and I will close with a brief description of those most generally used. The diamond is, of course, the stone of all stones. In regard to value, brilliancy, hardness and popularity it surpasses all the others. The base of the diamond is pure carbon, and they are found in crystalized shapes lying in the sand or imbedded in a matrix of quartz. The oldest diamond mines of the world are those of the East Indies which are now almost exhausted but from which some of the finest blue-white stones, called old mine stones, have been taken. The most diamonds are now taken from the South African mines, while the yield from the Brazilian mines has seriously diminished of late years, and unless some new fields are discovered or unless there is some truth in the story that diamonds are reproducing themselves in the older mines, there is danger that we may yet live to suffer from a diamond famine. In the East Indies they are found in a conglomerate of sandstone, consisting of quartz grains and disintegrated by the ferruginous sand. In the mountain chain Ralla-Nalla in Hindostan, the boulders and the sands of deserts and rivers yield diamonds mostly rounded or in granular form. The Island of Borneo also yields diamonds, and according to Jameson, diamonds

were found in the Indies in the coal formation. In Brazil they were discovered in 1728 by chance. After a few persons had gathered a great many rough diamonds and made a fortune out of their sale the government's attention was drawn to the matter, and in 1730 it was declared that all diamonds found there belong to the crown. In Russia the first diamond was discovered in July, 1829, by Humboldt, on the west side of the Ural Mountains. The washing establishments of the diamond in Brazil in the Tejuco district is conducted as follows: The waters of the small streams are diverted from their channels and the beds of those channels allowed to dry out, and the sediment consisting of a conglomerate of quartz pebbles kept together by oxide of iron is brought to one place for washing. There are benches of triangular form so as to keep 20 to 30 negroes busy; in the middle of this bench is a gutter with which is connected a trough and another gutter with a trough is joined further down. The negro who has collected in the dry season a large quantity of the sediment, is occupied in the rainy season in putting from 15 to 18 pounds at a time in the trough, spreading it there and allowing so much water to run over it until it runs off quite clear from the lower trough. He then begins to pick out the larger stones from the earthy part, then the smaller, until he comes to grains which he examines with the greatest care on account of the diamonds. As soon as a negro has found one he must make it known by clapping his hands, and the surveyor, who is seated on an elevated chair so he can oversee his work, takes and deposits it in a dish filled with water in which all those found during the day are collected; they are delivered twice a week to the government at Tejuco. The lines of the diamond district are guarded by sentinels who will not allow strangers to pass through without permission from the chief, and everybody must, on leaving the district, submit to a personal and strict examination and search by soldiers. All the diamonds produced are delivered up yearly to the government of Rio Janiero. In the years between 1772 and 1775, 5,000 negroes were employed and to-day they scarcely number 1,000. Their condition is pitiable; they receive a mere pittance for their work; they stand in water all day and in the mountainous regions are constantly exposed to the danger of being buried by the cavings of a bank. In order to encourage the negroes presents of tobacco, cloth, etc., are awarded according to the size of the diamond they find; the one who finds (for instance) a stone of 17 karats receives his entire liberty. Notwithstanding the most rigorous regulations and the most watchful attention of all the officers, the frauds in stolen diamonds are very considerable and it is estimated that the smuggling amounts to  $\frac{1}{3}$  the whole income. The smugglers, who are generally runaway slaves, examine the most remote parts of the district or steal the diamonds at night from the working establishments. Others, again, will take the stolen diamonds from the negroes and devise means of escaping with them, either in the soles of their boots or in hollow canes, etc., and it is a remarkable fact that all diamonds obtained from the smugglers are invariably larger and more beautiful than those to be obtained from the government. The thieves practice all manner of tricks even in presence of the surveyors. They conceal diamonds during the washing hours between the fingers, the toes, in the hair, ears, mouth, swallow them or throw them away with the other stones in order to pick them up at night, etc.

The diamonds, after being found in the mines, are sent from all parts of the world to Amsterdam and to Antwerp in Belgium, which are the great centers for diamond cutting; where the art of cutting it with its own powder was discovered by Lewis Van Berghen. The work of the lapidary is by no means insignificant, for in the way in which he cuts and finishes a stone a great part of its value depends. About  $\frac{1}{2}$  of the rough diamond is lost in cutting; the rough stone is usually cemented or sunk into a cup of molten lead at the end of a stick. It is then held over a revolving lead wheel which are fed with moistened diamond powder which imbeds itself into the metal until the upper side or table of the diamond is formed. The stone is then taken from the molten lead or cement and re-cemented at

another angle and again held over the wheel, and this operation is repeated until the stone is cut. But the mathematical accuracy of all the facets and sides that are obtained without the use of any measuring instrument whatever shows the skill and experience necessary to the diamond cutter. To show the amount lost in cutting I will here give the weight of some of the great diamonds before and after cutting:

|                          | When Rough.               | When Cut.                  | A Loss of.    |
|--------------------------|---------------------------|----------------------------|---------------|
| The Regent weighed . . . | 410 karats.               | 136 $\frac{1}{8}$ karats.  | $\frac{2}{3}$ |
| Grand Mogul " . . .      | 780 $\frac{1}{2}$ karats. | 279 $\frac{9}{16}$ karats. | $\frac{2}{3}$ |
| Kohinoor " . . .         | 186 $\frac{1}{2}$ karats. | 82 $\frac{1}{8}$ karats.   | $\frac{1}{2}$ |
| South Star " . . .       | 254 $\frac{1}{2}$ karats. | 124 $\frac{1}{8}$ karats.  | $\frac{1}{2}$ |

The color of the diamond takes in all the colors from white to black, the stones having a blue-white color being the most valuable, while the yellow ones are the cheapest; a blue stone being worth sometimes 5 times as much as a yellow stone of the same weight. The price of stones increases very rapidly in proportion to its weight. If a stone weighing 1 karat is worth \$100 per karat, a stone of the same quality weighing 2 karats is worth \$150 and weighing 3 karats \$200 per karat. Fine stones weighing over 6 karats a piece are comparatively rare. In the year 1871 precious stones to the value of \$2,346,732 were imported into the United States, and in 1880 the value of these imports was 6 $\frac{3}{4}$  millions. In 1881 gems to value of 8 $\frac{1}{2}$  millions passed through the Custom House and last year the amount was still greater. The New York market for jewels is to-day one of the greatest in the world; in no other country do working people own such valuable gems. Diamonds, rubies, cats'-eyes, sapphires, opals, onyxes, carbuncles and other valuable stones are now being sold at the rate of 6 to 1 as compared to the year 1871. There is to-day a finer selection of diamonds to be found in Maiden Lane and John street than in any other city of the world, and the retailer can buy them cheaper here than abroad; this is due to competition. The masses here purchase the jewels, while abroad the trade is confined to the wealthy and aristocratic. The American consumer of gems is more critical than the European, and while fine stones are eagerly bought up, poor ones are difficult to dispose of and find their way mostly to southern and eastern countries where the habit is to wear a great many precious stones without much regard to the quality.

The name diamond is derived from the Greek adamas, meaning invincible and referring to the hardness. The Syrians are said to have first known the diamond, and it was in early ages the subject of trade to the people of the East. The Carthagenians are said to have carried on their trade with the Etrurians who procured diamonds from the interior of Africa. Pliny mentions six species of diamonds, among which, however, the Indian are to be considered the true, in contradistinction to the quartz crystals which were likewise called diamonds in those times. The diamond was highly esteemed and many medicinal virtues were attributed to it, particularly against mania and as an antidote for poisons. It was then worn in the rough state. After the discovery in 1476 of cutting with its own powder, it was first cut in the table form with one row of facets on the surface. In 1520 the Rhomb cut was adopted and at last the form of brilliants (its present form) was invented in the reign of Louis XII. Cardinal Mazarin was the first who had diamonds polished in this form, some of which yet belong to the crown of France. The fact that the diamond was composed of carbon was first hinted at by Newton in 1675, and in 1694 the first trial was made at the Academy of Florence, the members of which volatilized diamonds within the focus of a mirror. Many experiments have been made to artificially produce diamonds, but it was not until 1880 that any faith was attached to these experiments, when, in that year, two Scotchmen, James McIrar in Glasgow and Mr. Hannay in London, succeeded in obtaining crystals similar to the diamond. Those of Mr. McIrar, however, were speedily proven not to be carbon, but a combination of silicic acids and many bases and therefore no diamonds; those of Mr. Hannay, however, were pro-

nounced real diamonds. The crystals were microscopically small worth from 1 to 2 fr. while 150 fr. was expended in the experiment, so as a practical measure the experiment was a failure; but there seems to be no reason to doubt that they were real diamonds.

From the diamond we pass to the ruby and sapphire which have the same composition but differ in color. The base of this group as well as of the emerald is alumina. Alumina, crystalized with iron rust, gives us the ruby; with other foreign substances we obtain the emerald, the white sapphire, the topaz, the amethyst, the indigo sapphire, the beryl, etc. The primitive form of these crystals is a six sided prisme, and nearly all of the rubies and sapphires are brought from India. Large stones are very rare and very high in price. A perfect ruby of 5 karats is worth 4 times as much as a diamond of the same weight, and I do not believe there is a 10 karat ruby in the United States. The largest ruby known is owned by the Shah of Persia and weighs 175 karats. There are 3 kinds of rubies, the Oriental ruby, the spinel ruby and the balas ruby; the first is the only true one. Sapphires are divided into Oriental sapphires, star sapphires and cats'-eyes. Star sapphires show a white light running in six rays resembling three white planes or stripes crossing themselves at one point. They are found in the colors of red, blue, yellow, etc. The stripes are caused by foreign substances or vacuities left between the molecules at the moment of crystalization. Cats'-eye sapphires are from Ceylon and has threads of white asbestos enclosed within it, and the light is reflected from these with intense brightness. When it is cut *en cabochon* a white band of light is seen floating in its interior which changes position as the gem passes before the eye; they are very rare and valuable. The sapphire was well known to the ancients and its name is taken from the Hebrew. Pliny gives a description of the star sapphire under the name of asteria. The finest ruby sapphire occurs in the Capelan mountains, near Syrian, a city of Pegu, in the kingdom of Ava. Large masses of blue sapphire of opaque color have been found in North Carolina, United States, and they are found in the sands of rivers or in boulders with garnets, zircons, kyanite and in basalt. Of topaz there are two varieties, the Oriental, of nearly pure alumina, and the occidental, which contains less than  $\frac{6}{10}$  of the subject. The true topaz is found in the Red Sea but is very difficult to get it. The cheaper topaz are found in Brazil, Mexico, Siberia and Saxony, and some have recently been discovered in Maine by Mr. Kunz, at one time a member of the chemistry class of this institute. Emerald, beryl and aquamarine are scientifically considered almost identical, but in commerce the value of the emerald is very much greater. The perfect emerald is one of the rarest and most exquisite of gems, but perfect emeralds are as scarce as hen's teeth. Its color is due to the presence, in combination with alumina, of a rather large quantity of oxide of chromium. Another gem has recently been discovered in North Carolina by Mr. Hidden, who also used to attend the Cooper Institute. It is similar to the emerald and far exceeds it in hardness and brilliancy; it is called Hiddenite after the discoverer, who is continuing explorations in the comparatively unexplored region of the United States, and who confidently expects to find diamonds and all the other gems in this country so as to render us independent of the markets of the old world. The beryl and the aquamarine have the general composition as the emerald but the oxide of chromium which distinguishes the last is replaced in them by oxide of iron. They are inferior gems and not very valuable. The aquamarine has little value as a gem yet it possesses the singular property of retaining its brilliancy by artificial light, while a magnificent blue sapphire which by day is dazzling, by night becomes dull and lifeless, while the cheap aquamarine shines with a brilliancy even more intense. The finest beryl known is in possession of Mr. Hope; it weighs more than 6 ounces and came from the East Indian mines. A magnificent beryl surmounts the globe in the royal crown of England.

The turquoise is another aluminous stone but only about half of its bulk is alumina. The blue color which makes it famous is

derived from a combination of phosphoric acid, copper, iron and water; it is abundant and though beautiful not costly. The occidental turquoise is a fossil ivory produced from the teeth of an extinct race of animals brought accidentally into contact with substances containing copper, which has been absorbed in quantities sufficient to color the entire mass. The turquoise stands alone among all the aluminum gems as having no electrical properties and no crystals.

The other stones used at the present day, such as pearls, coral, garnet, amethyst, onyx, cameo, intaglios, moss agate, etc., would require too much time to describe; so thanking you for the patience you have shown I must postpone the balance for some other time.

---

### The Hooking in of the Mainspring.

**M**ANY SPRINGS, says a contributor to a European horological paper, are broken owing to the hook in the barrel arbor being too long; therefore, this is a considerable item to be examined by the operator if he knows that a certain watch spring gets broken very often. Some of the closely made English watches, where a small barrel is used, frequently get their springs broken because the arbor hook stands too prominent. This hook should never be left longer than the thickness of the spring; this is quite sufficient to hold firmly, provided the hole in the spring is properly chamfered. The hole made in this end of the spring should be sufficiently large to allow the arbor hook plenty of room so that it will not raise or lower the center of the spring if the hook should be a little out of the center. In some of the flat Geneva watches, where a very thin spring is used, we have to be very careful in this particular; for, with such a thin—or low—spring, there is not the room to make the hole sufficiently large for the hook without making it a little weaker; or, if we are not careful, we are very liable to get the spring slightly ruptured in this part. Now, rather than run a risk of this kind, we had better stone off a part of the sides of the hook. Or, if the hook should be a little out of the center of the arbor we can then stone off one side only in order to bring the hole central.

When these little items are attended to we are not very likely to have the center of the spring chafing on the lid or bottom of the barrel unless the spring has not been properly finished, which is frequently the case with some of the cheap springs. Some of them have a rough burr on the edge which will often cause considerable trouble; for, in this instance, when the spring is nearly down and at its weakest point, it is then deprived of part of its strength by this chafing. Now, if the outside of the spring chafes, owing to getting in anyway bulged by riveting the hook on, this chafing is not so liable to affect the watch to such an extent, for, when this part of the spring is in action, there are more coils at work than when the spring is nearly exhausted; hence, its strength is better able to overcome the chafing. We see from this that the inner end of the spring should always be carefully examined; for we had better fit a spring that is a size too low than allow any chafing whatever.

---

### Clockmaking in the Black Forest.

**T**HE ROYAL Commission on Technical Education has published a report of their investigations, from which we make the following extract in reference to clockmaking in the Black Forest.

By means of lotteries and further grants, the Gewerbe-Halle was erected and opened in 1874, and the school was transferred to the new building, and was re-constituted and formally opened in June, 1877. The Government grant for this purpose was £650. The school is managed by a local council chosen from the surrounding districts, and consisting of eight persons. The annual budget is

£360, of which sum the Province of Freiburg contributes £25 and Villingen £50. The school is held in two small rooms, very ill-suited for the purpose, and a new building is in course of erection by the local Gewerbe-Verein (trade society) at a cost of from £1,250 to £1,500. There are at present eighteen pupils. Most of them are admitted free, and many are supported by exhibitions which are given by the neighboring towns, and may amount to £20 per annum. The school fee is £1 per annum. The students must have been previously engaged for at least two years in practical clockmaking before they can be admitted. The course lasts one year. In the morning they have theoretical studies, consisting of geometry, arithmetic, algebra, physics, mechanics, technology of watch and clockmaking, geometrical drawing, projection, technical drawing, bookkeeping and commercial arithmetic; together with thirty hours' practical work per week in the shops in the afternoon. The lathes and tools seem excellent of their kind, but the accommodation was very cramped.

By far the most important manufacture of the Black Forest is that of small carved clocks, many of them with musical accompaniments, known as cuckoo-clocks. In Triberg and a group of small towns and villages surrounding it, known as the clock country, 13,500 people, the population of upwards of ninety parishes, are engaged in clockmaking. We went to Schonach, a village in the hills above Triberg, where almost every cottage is the home of a clockmaker. The houses are large and substantially built. They are generally a considerable distance apart, and are surrounded with meadow-land and pastures. In addition to the home workers there are three or four small factories in which the wheels and other parts of clocks (Uhrenbestandtheile) are made. In one of these, visited by us, there were about five or six workmen employed and an apprentice. The power was derived from a small overshot wheel. There was a wire-cutting and straightening machine for preparing the pinions, a lathe for shouldering and tapering the pinions, some fine drills, a tooth-cutting machine, a shaping machine for the wheel teeth and a small press for driving on the bosses, etc. The machinery was ingenious and well adapted for its purpose. The rough castings made in the village were excellent. We were told that the men working piece work in the factories could earn from two to three marks per diem, though a very small proportion of the workmen earn the latter sum. In a second factory we visited subsequently, the movements made here were being fitted together and made into clocks. Carpenters were making the rough framework to contain the wheels, and others were preparing the varnished outer cases. The clock passed from hand to hand, one man adding the winding barrel, another the train of wheels, a third the escapement, and another placing the works into the case. The clocks were being packed up for sale in another part of the works. They seemed all pretty much of one pattern and of a very common description. The proprietor informed us that he produced clocks of exactly the same kind as those that were made in the cottages. They went mainly to various parts of Europe. None now go to England or to America. The Americans not only supply themselves with cheap clocks, but they have driven out the Black Forest maker from the English markets. The people employed at clockmaking live, we were told, very poorly—mainly on potatoes—though we saw soup and meat in some of the cottages. The cottages are very large; some of them contain as many as twelve families. Many of the people have only one or two rooms and a bit of land, probably about twenty perches, for which they pay from ten to fourteen marks rent per month. An old gentleman mowing in a very wet meadow was pointed out to us as the Bürgermeister of Schonach. We went into several of the cottages and saw the people at the work. The women were polishing the clock cases, and the men were making the wheel work. We were told here that an industrious worker at home could earn as much as a good workman in a factory. The water power is everywhere most ingeniously utilized, and the water itself is, as in many parts of England, employed for irrigation on the steep hill-sides.

The watchmakers' school of Paris is situated in the Faubourg du Temple, and when it was visited by the Royal Commissioners on Technical Education, it contained twenty-five pupils. The course extends over four years, the hours being from 8 A. M. to 7 P. M. in winter, and from 7 A. M. to 7 P. M. in summer, with an interval from 12 to 1.30 for meals and recreation. The theoretical instruction comprises French, the elements of mathematics, geometry and machine construction in their application to watch and clockmaking, the theory of the construction of watches, algebra, trigonometry, physics and chemistry, cosmography, bookkeeping and linear and industrial drawing. The practical instruction consists in the first year, of the use of tools and roughing-out work; in the second year, finishing; in the third year, escapements; and in the fourth year, regulating and repairs. The pupils, who must be fourteen years of age on admission, pay £12 per annum, and find their own small tools. For the support of the school, the "Syndicate" or Guild of Watchmakers annually contributes £560; the Government, £80; and the city of Paris, £40.

### How to Measure and Fit Spectacles.

EVERY JEWELRY store in the country is expected to carry a stock of spectacles and eye-glasses, and the question of measuring spectacle glasses, not only for old people, but for near-sighted people also, is one of weekly occurrence. It is not expected that every dealer in spectacles should be able to give a learned disquisition on optics, or diagnose every abnormal condition of the eye; but still there are certain things that every dealer who expects to suit his customers with suitable glasses should know.

He should know how to measure or obtain the focal distance of any convex or concave lens; he should also be able to determine the sum or difference of any combination of such lenses; and if the place to combine cylindrical or prismatic lenses with either of the above; but in all small places there is so little demand for either of the latter that it is hardly worth while to keep a stock of them on hand; and yet it would be well to *know when* a customer needs such glasses. If local resident dealers in spectacles knew more about this matter than they do, in fact knew what they *ought* to know, they could, if they wished, to a great extent break up the trade of itinerant swindling spectacle peddlers, who interfere no little with the legitimate trade of any regular dealer. These peddlers always sell inferior goods at exorbitant prices, and carry off a considerable sum of money from every town or city that they visit unless some one is prepared to show them up in their true light. I presume there is not a city or town in the United States but has been afflicted with these "Professors" just from "Vienna," "Berlin," "Munich," or some other European city, who has "just come to this country with the *only* spectacles that are or ever have been made upon truly scientific principles, approved by all the scientific men and crowned heads of Europe," etc. They manage to sell quite a number of spectacles in most every place they visit, and at from three to ten times their value.

We would suggest to those engaged in the trade that as soon as one of these "Dr. Eisenbarts" makes his appearance in a city, that the trade put a "stunning" advertisement in their local paper proposing to sell "spectacles at from one-half to one-fourth the price charged for the same quality of goods by itinerant peddlers." Something of this kind usually kills them off at once and their stay is very limited.

But let us come back to the main subject.

Probably every dealer knows how to measure a convex lens, but still there is no harm in stating that to do so a wall or partition furthest from some window, should be selected at a point near the counter shelf if possible, on which have a measure about sixty inches long, graduated in inches, counting *from* the wall; to measure

a convex lens hold it so that the light from the window will pass through it, and form an image of the window frame or some out-of-door object on the wall, moving the lens back and forth and near the measure until you find the point where the image is the most distinct; note the distance in inches the lens is from the wall, which will be the focal distance of the lens, whether it be a plano convex, double convex or concavo-convex, usually called periscopic convex. This is getting the focus by refraction.

A *concave* lens cannot by itself be measured by refraction of light, but it can be by *reflection*. To do so, hold the lens the same as you would a convex, but hold a white card or piece of paper between it and the light in such a position as will allow the light to pass over the card and fall upon the face of the lens, remembering that the angle of reflection is always equal to the angle of incidence, when an image of the window frame or other object will be reflected on the card, moving it back and forth until a distinct image is formed; note the distance the card is from the glass in inches and fractions of an inch; and if a plano-convex multiply this number by 4, and if a *double* concave multiply by 2, which gives you the focal distance or number of the lens. For instance, if a plano-convex lens showed the image of  $4\frac{1}{2}$  inches, it would be number 18; if a double concave showed the image at the same distance, it would be number 9.

There is another way to ascertain the focus of a concave lens, viz., by neutralization. For instance, an 18 convex will neutralize an 18 concave lens; if you look through the two when placed together, it will be the same as looking through a piece of plane or flat glass.

Some parties arrange every number of lens in their strips of wood, say about 6 or 8 lenses in each. Then to find the focus of a concave lens they find what number of convex will just neutralize the concave, so that the next number stronger or lower number will show a focus on the wall at same distance; this is the method usually adopted to ascertain the focus of a concave lens, especially the periscopic concave. This method is not generally accurate for the following reason: Suppose we have a number 16 convex and a number 18 concave; no image would be formed at any ordinary distance for measuring; but if we hold them at a distance of 144 inches a distinct image will be formed. It is only the numbers about which we can be certain in this way. But if a convex lens much stronger than the concave is used, we can get at the result more accurately and with the same facility. Let the numbers of all lenses be represented by vulgar fractions; the convex lens will always be designated by the + (plus) sign, and the concave by the - (minus) sign, and any one having a slight knowledge of algebra will be able to determine the number of any lens, either concave or convex, also the sum or difference of any combination of them.

To make this plain we will give a few examples, commencing with the convex:

A No. 10 and a No. 15, if placed together, would be the same as one lens No. 6; for  $\frac{1}{10} + \frac{1}{15}$  (by reducing to a common denominator)  $= \frac{3}{30} + \frac{2}{30} = \frac{5}{30} = \frac{1}{6}$ . Again let us suppose that a customer, who has had a cataract removed from his eyes, wants "cataract" glasses; we find that by putting on a pair of No. 5 and a pair of No. 8 he can see distinctly; then "cataract" glasses No. 3 would suit him as this would be the nearest number indicated by their combination, for  $\frac{1}{5} + \frac{1}{8} = \frac{8}{40} + \frac{5}{40} = \frac{13}{40} = \frac{1}{3.113}$ ; in other words,  $X = \frac{1}{5} + \frac{1}{8} = \frac{1}{3.113}$ .

Supposing we have an unknown concave lens and wish to get its focus; we test it with a No. 10 convex, for instance, and find that the two produce a focus on the wall at a distance of 30 inches; then we say  $X = \frac{1}{10} - \frac{1}{30} = \frac{3}{30} - \frac{1}{30} = \frac{2}{30} = \frac{1}{15}$ , consequently our concave lens is a No. 15. In this case the combination has taken a certain amount *from* the convex lens or reduced its value, so we must subtract the  $\frac{1}{30}$  from the  $\frac{1}{10}$ , both being positive or + numbers, for if we add  $-\frac{1}{30}$  to  $+\frac{1}{10}$  we have  $+\frac{1}{15}$ .

Suppose a near-sighted customer should try on a pair of No. 10 near-sighted or concave spectacles, which, with a pair of No. 15 convex, together just suited him; what number of concave spec-

tacles would suit him? We say  $X = -\frac{1}{10} + \frac{1}{15} = -\frac{3}{30} + \frac{2}{30} = -\frac{1}{30}$ ; in other words, No. 30 concave lenses would be required. Suppose that a No. 6 concave, with a No. 15 convex suited, then we have  $X = -\frac{1}{6} + \frac{1}{15} = \frac{1}{30} + \frac{2}{30} = \frac{3}{30} = \frac{1}{10}$ .

To find the focus of a combination of concave lenses, proceed the same as with convex lens. For example: A No. 8 concave and a No. 12 concave would be the same as a  $4\frac{2}{3}$  concave. We prove this by the following statement:  $X = -\frac{1}{8} + (-\frac{1}{12}) = -\frac{3}{24} + (-\frac{2}{24}) = -\frac{5}{24} = \frac{1}{4.8}$ , always reducing until the numerator is 1, when the denominator will show the number required.

We have endeavored to express ourself as intelligibly as possible and hope that the tyro optician will not be puzzled to understand us and focus his glasses.

---

### Some Famous Diamonds.

WHILE MUCH has been written and printed about the famous diamonds of the world, it still appears that too much cannot be said about them to satisfy the cravings of the public. When one cannot possess a thing it is some satisfaction to read about it. The following account of some of the most noted diamonds we find in a recent English journal. If it does not tell anything new about them it bears the impress of being historically correct, though the writer himself cannot vouch for that absolutely:

To the big diamonds of the world another has just been added. Advices from the Cape report that on March 27 last a digger was so fortunate as to find a rough diamond measuring nearly two inches in length and an inch and a quarter in diameter, and weighing no less than three hundred and two karats. "This," says Mr. Bryce-Wright, "is by far the largest precious stone yet discovered in South Africa, or, in fact, elsewhere, if we except the Pitt and the Mattam in their uncut state, and some diamonds of apocryphal history." It is a common fallacy to suppose that all the large diamonds existing in different parts of the globe are as well known and as capable of substantiation as pictures with an undoubted pedigree. Truth compels us to state that many of the so-called big diamonds known to history are little deserving of their reputation.

For instance, it is generally believed that the Braganza diamond—which is now included among the Portuguese State jewels—far exceeds all other gems in size, weight and value. The Braganza was found nearly a century and a half since in Brazil, a country which, rich as it undoubtedly is in precious stones of all kinds, has hitherto yielded but few large diamonds. "Brazil," says a recent writer of authority, "produces yearly from twenty-five to thirty thousand karats of diamonds, of which not more than nine thousand are capable of being cut, the rest being either very small or of very inferior quality." If the Braganza stone, which weighs nearly seventeen hundred karats, or about twelve ounces, and is as big as a large egg, were beyond all question a diamond, its commercial value would be simply incalculable. It has never been cut, however, and the Portuguese government, jealous of any possible damage to the national credit which might ensue, has always exhibited a reluctance to have "the Braganza" closely examined, or even handled, by experts. A widespread belief has therefore sprung up that, instead of being a diamond, it is only a white topaz.

Even the Mattam diamond, which has remained for the last century and a quarter in possession of the family of a Rajah in Borneo, where the stone was originally found, has not altogether escaped some invidious insinuations that it also is a topaz. Be the stone what it may, it has always been held in exceptional honor by its possessors for the time being as a talisman which brought them happiness, long life and good luck, just as the Kohinoor was always regarded, before the birth of the East India Company, as conferring upon its owner supremacy in Hindustan. No temptation—and many have been offered—has ever availed to induce the Rajah and

his successors to part with the Mattam diamond; and, although many fierce battles have been fought for its possession, it has never left the Rajah's family.

We come next to that magnificent stone called variously the Great Mogul and the Kohinoor, or "Mountain of Light," which, in 1850, became the Queen's property. Its reputed history might vie with that told by the young German baroness, in Sir Walter Scott's beautiful romance of "Anne of Geierstein," to Arthur Philipson, about that lustrous opal gem which turned pale on the approach of poison, and which an ancestor of the baroness won in battle from the Sultan of Trebizond. The history of the Kohinoor dates back vaguely to a period anterior to the birth of Christ, although nothing is known about it with positive certainty until it was owned in the fourteenth century by the Rajah of Malwa. From him it passed successively into the possession of the Bahmani, Khili, Lodi and Mogul kings until, in 1739, it came into the hands of Nadir Shah, the Persian, who gave it the name of "Mountain of Light." When Nadir Shah, at the head of his wild Tartars, burst over the blue mountains beyond the Indus, and descended upon Delhi, he demanded that everything in the treasury of the Mogul dynasty should be surrendered to him. The great-grandson of Aurengzebe, Mohammed Shah, valued the Kohinoor so highly, on the ground chiefly that it conferred supreme power and good fortune upon its temporary holder, that he kept the gem back from Nadir Shah by concealing it in his own turban. The story runs that a woman of his harem, who had received unworthy treatment from Mohammed, secretly apprised his conqueror where the jewel was hidden. The two rulers sat down together at a great feast held in Dehli, and, with protestations full of oriental insincerity, swore eternal friendship and love for each other. Suddenly Nadir Shah declared, to his mortified and dissimulating neighbor, that before the feast closed he must exchange turbans with him. Snatching off his own head-dress Nadir Shah gave it to his brother chief and possessed himself of the treasure. No sign of emotion or reluctance was exhibited by the subtle Eastern ruler, who trusted that the hidden jewel would escape detection, and that he should soon be able to regain possession of it. Scarcely had he entered his own tent when Nadir Shah searched his beaten enemy's turban, and within its folds he discovered that priceless gem, to which he instantly gave the name of "The Mountain of Light." He carried it back with him to Khorassan, investing it, in his delight, with all sorts of miraculous properties, but when he died his feeble son was unable to retain it. From him it passed to Ahmed, the founder of the Cabul dynasty, and it ultimately became the property of Shah Sujah, who, when driven out of Cabul and bereft of sight, took the gem with him, and clung to it with more tenacity than to his life. His wanderings brought him at last to Lahore, where he was the guest of Runjeet Singh, "the Lion of the Punjaub." A rumor reached Runjeet's ears that Shah Sujah carried the Kohinoor about his person, and he employed every device of menace, entreaty and cajolery to get hold of the precious treasure. For a long time he was unsuccessful, until, baffled in his efforts, he resolved to try his hand upon the Begum, who was Shah Sujah's wife. At length, on June 1, 1813, Shah Sujah resigned the glorious gem to his conqueror, avowing that it should alone belong to those who were triumphant over their enemies. Every means was used to induce Runjeet to bequeath it on his deathbed to the idol Juggernaut, but he preferred to hand it to his successor as the symbol of empire. When the Punjaub was annexed by the English government, the crown jewels at Lahore were taken from the Maharajah Dhuleep Singh, who was then a boy, and it was stipulated by the East India Company that the Kohinoor should be delivered to her Majesty. Lord Dalhousie sent two officers in charge of the gem to England, and on June 3, 1850, it passed into the possession of the future Empress of India. Those who remember the great exhibition of 1851 will recall the sensation which the Kohinoor created, and it was then valued at something like one hundred and fifty thousand pounds. It had, however,

been so unskillfully cut that Sir David Brewster recommended that Herr Voorsanger, an expert from Amsterdam, should be invited to England in order that he might cut out the flaws and reset it. On July 6 the Duke of Wellington placed the stone upon the cutting mill over which Herr Voorsanger presided, and its weight was decreased by the process from one hundred and eighty-six to one hundred and two karats.

It ranks in general estimation with the celebrated Pitt diamond, bought by the grandfather of the first Earl of Chatham from an Indian diamond merchant for twelve thousand five hundred pounds. From Governor Pitt it was bought for a fabulous sum—considerably more than one hundred thousand pounds—by the Regent-Duke of Orleans, and having experienced all sorts of vicissitudes during the French revolution, it passed into the hands of the Emperor Napoleon, who had it fixed in the hilt of his sword. Before it was cut it weighed more than four hundred karats, but it was reduced in the cutting mill to about one hundred and forty. As the greatest and most valuable gem among the crown jewels of France, it and the Kohinoor have always ranked among the most illustrious diamonds of the world.

Within the last few years South Africa has successfully asserted its claim to vie with Brazil, with Ceylon and with Australia as a producer of precious stones, and among famous gems the Dudley diamond and the Stewart diamond, both found at the Cape, have lately come into prominence. It may be that the great diamond, weighing, in the rough, more than three hundred karats, and just found in the Kimberley mines of South Africa, is destined, when it is brought under Mr. Bryce-Wright's inspection, to equal, even if it does not surpass, in value and luster, the Kohinoor and the Pitt.

South Africa is distinguished for the largeness of the diamonds already found among its mountains and in the beds of its rivers, and, although the market for small diamonds is said at this moment to have shared in the common depression of commerce all over the world, there is little probability that large stones of pure quality will ever lack a wealthy purchaser. It is a characteristic, for instance, of those few millionaires in the United States who, like Mr. W. H. Vanderbilt and Mr. Mackay, can afford to buy rare precious stones, that they are content with nothing but the purest and most costly gems. Anyhow, the arrival in England of the latest paragon from South Africa will be eagerly awaited by the large and increasing circle of diamond fanciers, who have made the English metropolis the greatest center and distributor of precious stones in the world.

## Computation of Time and Changes of Style in the Calendar.

Addressed to Students of History and Genealogy.

[BY SPENCER BONSALE.]

Continued from page 205.

### CALENDAR OF THE FRENCH REPUBLIC FROM 1792 TO 1806.

ALTHOUGH Encyclopædias and other works mention the French Republican Calendar, and in some cases attempt to give copies of it, I have yet to find, in the English language, a correct exemplar, or one that can be used for practical purposes. The Calendar here given may be relied on for perfect accuracy in every particular, as it has been prepared directly from the "Almanach National de France," and the "Gazette Nationale, ou Le Moniteur Universel."

The zeal for innovation which accompanied the French revolution induced the rulers to change their calendar along with their government. It was decreed by the National Convention, in the autumn of 1793, that the vulgar era should be abolished in all civil concerns; that the new French era should be reckoned from the foundation of the republic, September 22, 1792, of the vulgar era, on the day of the true autumnal equinox; that each year should begin on the midnight of the day on which the autumnal equinox falls; and that the

first year of the French republic had begun immediately after 12 o'clock P. M. of the 21st of September, 1792, and had terminated on the midnight between the 21st and 22d of September, 1793. In order to effect a correspondence between the seasons and the civil year, it was decreed that the fourth year of the republic should be the first sextile, or leap year, that a sixth complementary day should be added to it, and that it should terminate the first *Franciade*; that the sextile, or leap year, should take place every four years, and should mark the close of each *Franciade*; that the first, second, and third centesimal years, viz., 100, 200, and 300 of the republic, should be common, and that the fourth, viz., 400, should be sextile; and this should be the case every four centuries until the fortieth, which should terminate with a common year.

It was intended that the year should have been divided into ten parts, conformably to the decimal system; but, in taking the divisions of the months, the twelve revolutions of the moon round the earth made it absolutely necessary to admit twelve months. These were named after the seasons to which they belonged.

|        |             |                   |                             |          |
|--------|-------------|-------------------|-----------------------------|----------|
| Autumn | Vendémiaire | Vintage month     | September 22 to October 21, | 30 days. |
|        | Brumaire    | Foggy month       | October 22 to Nov. 20,      | 30 "     |
|        | Frimaire    | Frosty month      | November 21 to Dec. 20,     | 30 "     |
| Winter | Nivôse      | Snowy month       | December 21 to Jan. 19,     | 30 "     |
|        | Pluviôse    | Rainy month       | January 20 to Feb. 18,      | 30 "     |
|        | Ventôse     | Windy month       | February 19 to March 20,    | 30 "     |
| Spring | Germinal    | Germinating month | March 21 to April 19,       | 30 "     |
|        | Floréal     | Flowery month     | April 20 to May 19,         | 30 "     |
|        | Prairial    | Meadow month      | May 20 to June 18,          | 30 "     |
| Summer | Messidor    | Harvest month     | June 19 to July 18,         | 30 "     |
|        | Thermidor   | Hot month         | July 19 to August 17,       | 30 "     |
|        | Fructidor   | Fruit month       | August 18 to Sept. 16,      | 30 "     |

As the French months consisted of 30 days each, making in all 360 days, the remaining five days required to complete the year were called *complementary days* and *sans-culottides*. They were named as follows:

|             |                      |                          |
|-------------|----------------------|--------------------------|
| 1. Primedi  | Fête de la Vertu     | The Virtues, Sept. 17th. |
| 2. Duodi    | Fête du Génie        | Genius, " 18th.          |
| 3. Tridi    | Fête du Travail      | Labor, " 19th.           |
| 4. Quartidi | Fête de l'Opinion    | Opinion,* " 20th.        |
| 5. Quintidi | Fête des Récompenses | Rewards, " 21st.         |

The intercalary day of every fourth year was called *La sans-culottide*, and was to be the Festival of the Revolution, to be dedicated to a grand solemnity, in which the French should celebrate the period of their enfranchisement, and the institution of the Republic. The National oath, "To live free or die," was to be renewed.

Each day was divided according to the decimal system, into ten parts or hours, and these into ten others, and so on.

Each month was divided into three decades, each consisting of ten days; the names of which were taken from the Latin numerals. The first was called *Primedi*, 2d *Duodi*, 3d *Tridi*, 4th *Quartidi*, 5th *Quintidi*, 6th *Sextidi*, 7th *Septidi*, 8th *Octidi*, 9th *Nonidi*, and 10th *Décadi*. The last was the day of rest, and superseded the former Sunday.

This decimal arrangement did not appear to give general satisfaction, the French Republicans rarely adopting the new names of the days, in dating their letters, or in conversation, but using the number of the day of each month of their calendar. Thus: the 6th, 17th, 28th, or 30th Nivôse, the 9th Fructidor, the 12th Germinal, the 16th Frimaire, the 23d Prairial, etc. The system was abandoned, and religious worship restored after *Septidi*, † 27th Germinal, year X. (17th April, 1802), and the next day, Sunday, commenced with the usual names of the days of the week: *Dimanche*, *Lundi*, *Mardi*, *Mercredi*, *Jeudi*, *Vendredi*, and *Samedi*.

\* "This festival, absolutely original, and perfectly adapted to the French character, was to be a sort of political carnival of twenty-four hours, during which people should be allowed to say or to write with impunity, whatever they pleased concerning every public man. It was for opinion to do justice upon opinion itself; and it behooved all magistrates to defend themselves by their virtues against the truths and the calumnies of that day."—Thiers' *History of the French Revolution*.

† See *Gazette Nationale ou Le Moniteur Universel*, 18, 20 Germinal, year X. (8, 10 April, 1802) for act of the Corps-Législatif, and speech of Lucien Bonaparte.

This calendar existed until the 10th Nivôse, year XIV. (the 31st December, 1805). The next day, January 1, 1806, the Gregorian mode of computation was restored.

With the aid of the preceding and following tables, a complete calendar for any month, or year, of the French Republic can easily be constructed.

|                               |                                |
|-------------------------------|--------------------------------|
| From 22 Sept. 1792 } <b>I</b> | From 23 Sept. 1800 } <b>IX</b> |
| To 21 " 1793 } <b>II</b>      | To 22 " 1801 } <b>X</b>        |
| From 22 " 1793 } <b>III*</b>  | From 23 " 1802 } <b>XI*</b>    |
| To 21 " 1794 } <b>IV</b>      | To 22 " 1803 } <b>XII</b>      |
| From 22 " 1794 } <b>V</b>     | From 23 " 1804 } <b>XIII</b>   |
| To 21 " 1795 } <b>VI</b>      | To 22 " 1805 } <b>XIV</b>      |
| From 22 " 1795 } <b>VII*</b>  | To 31 Dec. 1805 }              |
| To 21 " 1796 } <b>VIII</b>    |                                |
| From 22 " 1796 }              |                                |
| To 21 " 1797 }                |                                |
| From 22 " 1797 }              |                                |
| To 21 " 1798 }                |                                |
| From 22 " 1798 }              |                                |
| To 21 " 1799 }                |                                |
| From 22 " 1799 }              |                                |
| To 21 " 1800 }                |                                |

\* Sextile or leap years.

The calendar, although reckoned from the 22d of September, 1792, was not introduced until the 8th of Brumaire, year II. (29th of October, 1793). See *Le Moniteur* of that date.

| Years of the Republic. |                        | IV. 1795-6.*           |                     | XII. 1803-4. |  |
|------------------------|------------------------|------------------------|---------------------|--------------|--|
| <b>I.</b> 1792-3       | <b>V.</b> 1796-7       | <b>VIII.</b> 1799-1800 | <b>XI.</b> 1802-3   |              |  |
| <b>II.</b> 1793-4      | <b>VI.</b> 1797-8      | <b>IX.</b> 1800-1      | <b>XIII.</b> 1804-5 |              |  |
| <b>III.</b> 1794-5     | <b>VII.</b> 1798-9     | <b>X.</b> 1801-2       | <b>XIV.</b> 1805    |              |  |
| 1 Vendémiaire 22 Sept. | 1 Vendémiaire 23 Sept. | 1 Vendémiaire 24 Sept. |                     |              |  |
| 9 " 30 "               | 8 " 30 "               | 7 " 30 "               |                     |              |  |
| 10 " 1 Oct.            | 9 " 1 Oct.             | 8 " 1 Oct.             |                     |              |  |
| 30 " 21 "              | 30 " 22 "              | 30 " 23 "              |                     |              |  |
| 1 Brumaire 22 "        | 1 Brumaire 23 "        | 1 Brumaire 24 "        |                     |              |  |
| 10 " 31 "              | 9 " 31 "               | 8 " 31 "               |                     |              |  |
| 11 " 1 Nov.            | 10 " 1 Nov.            | 9 " 1 Nov.             |                     |              |  |
| 30 " 20 "              | 30 " 21 "              | 30 " 22 "              |                     |              |  |
| 1 Frimaire 21 "        | 1 Frimaire 22 "        | 1 Frimaire 23 "        |                     |              |  |
| 10 " 30 "              | 9 " 30 "               | 8 " 30 "               |                     |              |  |
| 11 " 1 Dec.            | 10 " 1 Dec.            | 9 " 1 Dec.             |                     |              |  |
| 30 " 20 "              | 30 " 21 "              | 30 " 22 "              |                     |              |  |
| 1 Nivôse 21 "          | 1 Nivôse 22 "          | 1 Nivôse 23 "          |                     |              |  |
| 11 " 31 "              | 10 " 31 "              | 9 " 31 "               |                     |              |  |
| 12 " 1 Jan.            | 11 " 1 Jan.            | 10 " 1 Jan.            |                     |              |  |
| 30 " 19 "              | 30 " 20 "              | 30 " 21 "              |                     |              |  |
| 1 Pluviôse 20 "        | 1 Pluviôse 21 "        | 1 Pluviôse 22 "        |                     |              |  |
| 12 " 31 "              | 11 " 31 "              | 10 " 31 "              |                     |              |  |
| 13 " 1 Feb.            | 12 " 1 Feb.            | 13 " 1 Feb.            |                     |              |  |
| 30 " 18 "              | 30 " 19 "              | 30 " 20 "              |                     |              |  |
| 1 Ventôse 19 "         | 1 Ventôse 20 "         | 1 Ventôse 21 "         |                     |              |  |
| 10 " 28 "              | 9 " 28 "               | 9 " 29 "               |                     |              |  |
| 11 " 1 March           | 10 " 1 March           | 10 " 1 March           |                     |              |  |
| 30 " 20 "              | 30 " 21 "              | 30 " 21 "              |                     |              |  |
| 1 Germinal 21 "        | 1 Germinal 22 "        | 1 Germinal 22 "        |                     |              |  |
| 11 " 31 "              | 10 " 31 "              | 10 " 31 "              |                     |              |  |
| 12 " 1 April           | 11 " 1 April           | 11 " 1 April           |                     |              |  |
| 30 " 19 "              | 30 " 20 "              | 30 " 20 "              |                     |              |  |
| 1 Floréal 20 "         | 1 Floréal 21 "         | 1 Floréal 21 "         |                     |              |  |
| 11 " 30 "              | 10 " 30 "              | 10 " 30 "              |                     |              |  |
| 12 " 1 May             | 11 " 1 May             | 11 " 1 May             |                     |              |  |
| 30 " 19 "              | 30 " 20 "              | 30 " 20 "              |                     |              |  |
| 1 Prairial 20 "        | 1 Prairial 21 "        | 1 Prairial 21 "        |                     |              |  |
| 12 " 31 "              | 11 " 31 "              | 11 " 31 "              |                     |              |  |
| 13 " 1 June            | 12 " 1 June            | 12 " 1 June            |                     |              |  |
| 30 " 18 "              | 30 " 19 "              | 30 " 19 "              |                     |              |  |
| 1 Messidor 19 "        | 1 Messidor 20 "        | 1 Messidor 20 "        |                     |              |  |
| 12 " 30 "              | 11 " 30 "              | 11 " 30 "              |                     |              |  |
| 13 " 1 July            | 12 " 1 July            | 12 " 1 July            |                     |              |  |
| 30 " 18 "              | 30 " 19 "              | 30 " 19 "              |                     |              |  |
| 1 Thermidor 19 "       | 1 Thermidor 20 "       | 1 Thermidor 20 "       |                     |              |  |
| 13 " 31 "              | 12 " 31 "              | 12 " 31 "              |                     |              |  |
| 14 " 1 Aug.            | 13 " 1 Aug.            | 13 " 1 Aug.            |                     |              |  |
| 30 " 17 "              | 30 " 18 "              | 30 " 18 "              |                     |              |  |
| 1 Fructidor 18 "       | 1 Fructidor 19 "       | 1 Fructidor 19 "       |                     |              |  |
| 14 " 31 "              | 13 " 31 "              | 13 " 31 "              |                     |              |  |
| 15 " 1 Sept.           | 14 " 1 Sept.           | 14 " 1 Sept.           |                     |              |  |
| 30 " 16 "              | 30 " 17 "              | 30 " 17 "              |                     |              |  |

Complementary days.

|    |    |   |
|----|----|---|
| 1. | 17 | " |
| 2. | 18 | " |
| 3. | 19 | " |
| 4. | 20 | " |
| 5. | 21 | " |
| 6. | 22 | " |

Complementary days.

|    |    |   |
|----|----|---|
| 1. | 18 | " |
| 2. | 19 | " |
| 3. | 20 | " |
| 4. | 21 | " |
| 5. | 22 | " |
| 6. | 23 | " |

The 6th Complementary day was used only for the sextile years III., VII. and XI.

NOTES ON SUNDRY CALENDARS.

BY ALEXANDER WILCOCKS.

The very interesting article by Mr. Spencer Bonsall on "Changes of Style in the Calendar," rather piques the curiosity of students of history and genealogy as to the character of other calendars which have had, or may still have, existence.

On examining the fifty short chapters in which the subject of Calendars is treated by M. François Arago in his "Astronomie Populaire," one is rewarded by learning some valuable facts regarding them.

Perhaps the most interesting of the non-Christian Calendars described by him, because of its superior accuracy, was that of Persia.

The following is a translation of Mons. Arago's account of it as it appears in Chapter XIX., Book XXIII.:

THE PERSIAN YEAR IN THE ELEVENTH CENTURY.

The Persians had already adopted in the eleventh century an intercalation which brought their civil year very near to the astronomical one, and which maintained the equinoxes and the solstices upon the same days of the civil year.

It was thus constituted: Three ordinary years of 365 days were followed by a leap year of 366 days, and this period of four years was repeated seven times. This was succeeded by a period in which the leap year did not occur until after four ordinary years.

Let us ask what length of year ensues from this mode of intercalation? Here is the answer:—

The first seven periods form a total of 28 years, the eighth period comprises five years, making a total of 33 years.

Therefore, in 33 years the Persians intercalate 8 days. Hence the fractional part of the year beyond the 365 days may be expressed thus,

$$\frac{8 \text{ days}}{33} = 0.2424 \text{ days.}$$

|  |           |                             |
|--|-----------|-----------------------------|
| 10,000 years with the Persian mode of intercalation comprise | - - - - - | 3,652,424 <sup>ds</sup>     |
| 10,000 astronomical years comprise                           | - - - - - | 3,652,422 <sup>ds</sup> .64 |

The difference is only - - - - - 1<sup>dy</sup>.36

Between the civil year as amended by Gregory XIII.† and the astronomical year there is a difference of - - - - - 2<sup>ds</sup>.36

Thus it appears that the Persian mode of intercalation is superior in accuracy to the Gregorian Calendar now adopted by the greater part of Europe, and of the New World.

In his "History of the French Revolution," M. Thiers describes the twelve months into which the year was divided by the Directory. He also tells us of the complementary days, and the "sans culottides;" but about the manner in which the "Republican year" was made to keep pace with the astronomical year he says absolutely nothing.

More strange still than the above is the fact that while M. Arago describes with minuteness so many different calendars, upon the above interesting point in the Republican Calendar he says as little as does M. Thiers.

Upon one point only he enlarges, and thereon bases the reflection, that as the exact day on which the autumnal equinox occurs was to be calculated upon the longitude of the meridian of Paris, the founders of the Republican Calendar might have been assured that national jealousy would certainly prevent the people of other countries from adopting it.

In the "Atlas Universel d'Histoire et de Géographie," par M. N. Bouillet, under the head of "Chronologie," may be found a short but minute account of the Republican Calendar.

† *Astronomie Populaire*, vol. iv., p. 688.

\* For the year IV. of the Republic, after the 28th of February, use the first column under the year I., as 1796 was a Gregorian leap year. The 10th Ventôse was the 29th of February.

The following is a translation of the article:—

REPUBLICAN ERA.

This era, the most recent of all, is also that which has lasted the shortest time. Established in France by a decree of the Convention on the 5th October, 1793, it had a retroactive commencement from the 22d Sept., 1792.

As precedently, the ordinary years were to contain 365 days, those which contained 366 days were to be called *sextiles* (and not *bisextiles*). The difference consisted solely in the mode of intercalation.

It was ordered that the year 3 should be sextile, that from this epoch each fourth year should be sextile until the year 15; after which a 366th day should not be added till the year 20.

This sequence was to be repeated until the years 48 and 53 of the era. Thereafter a cycle of 33 years should be conformed to, in which every fourth year a sixth day called *épagomène* (that is to say, intercalated) should be added, but in such a manner that after the seventh intercalation no addition should be made to the complementary days until the fifth year, when the 8th intercalation was to be made.

Special decrees in the years 1793 and 1794 abolished this mode of intercalation, and ordered that the first day of the year should always be that of the autumnal equinox, which was to be ascertained each year by astronomical calculations.

The duration of the Republican era was only 13 years and 100 days. By a *Senatus consultum* of the 22d Fructidor in the year 13, the conservative senate abolished this institution, and the 10th Nivôse of the year 14 was followed immediately by the 1st of January, 1806.

In the preparation of the article "Chronologie" in the "Atlas," from which the above is translated, the Collaborator of Mons. Bouillet was Mons. Caillet.

It will be observed that by the combined testimony of these two authorities, the mode of intercalation by which the Convention proposed to keep their civil year in coincidence with the astronomical year was absolutely identical with that adopted in Persia in the Eleventh Century.

Another calendar described in detail by M. Arago is that of the Christian Church. All are familiar with the mode in which the time for the celebration of Easter was determined at the Council of Nice.

M. Arago mentions a fact with which most persons are unacquainted, viz., that "the paschal moon is a conventional moon; and may arrive at its full one or two days before or after the true or mean astronomical moon."

"Hence ensue frequent reclamations of the public, being unaware that the time of Easter is based upon the phases of a fictitious or imaginary moon, and not upon those of the real moon." "Astronomers are, therefore, taxed with ignorance or carelessness for causing the celebration of Easter to take place a month after the proper time."

There are other calendars and sundry eras described by M. Arago which would repay perusal by those interested in such subjects.

The same is true of the subject of Chronology as treated in the "Atlas d'Histoire et de Géographie."

[THE END.]

### To Prevent Watches from being Magnetized.

AN INTERESTING article in the July number of the London *Horological Journal*, written by Mr. Thos. D. Wright, relates how he made watches that were proof against magnetism. We extract as follows:

In consequence of the great advance in electrical pursuits during the last few years, involving the use of dynamo machines and other powerful magnetic appliances, considerable inconvenience has been caused by the liability of the ordinary watch to become magnetized; and a consequent demand, which will probably grow, for watches

unaffected in their timekeeping properties by magnetic influences. Even when the tedious process of demagnetizing has been thoroughly successful, the cure is not of much use to the watch as usually made, because it may be as bad as ever the next day, if brought too near a powerful magnet.

As I have had to make some watches during the last two or three years which should be proof against magnetism, so far as their timekeeping was concerned, it may interest some of your readers to know how far the attempts were successful, and how the desired result was obtained. In making such a watch, we must assume that it will be subjected to such powerful magnetic attraction that every particle of steel in it becomes a permanent magnet. We have next to consider how far each of such parts so magnetized will affect the time. This, perhaps, could only be determined by experiment. I concluded—and the result justified these conclusions—that the motion of the arbors and pinions was really so slow that it would not matter how much they were magnetized. I was afraid of the escape pinion, which has an appreciable radius, and moves much faster than the others; but although I have found in each case that it had become powerfully magnetized, I could not detect that it had the slightest effect on the time.

I had heard of brass mainsprings being used, but I neither feared nor found any inconvenience from using the ordinary steel mainspring. The only parts to which attention need be paid are the escapement, the balance, and the balance spring. The first one I made had pallets, lever, and roller of brass. The pallet maker complained that he could not polish the pallet stones well, as the brass seemed to mingle with the polishing stuff, and prevent him from getting necessary smoothness. The latter ones, therefore, have been made of aluminium bronze, which has proved to be better than brass in many ways for each of these pieces; the balances in each case have been ordinary gold ones; the balance springs have been Paillard's palladium springs, as sold by Messrs. Haswell. It is also advisable not to use steel hands, *especially the seconds hand*.

These watches have been submitted to severe tests; have been saturated with magnetism; have been placed on a dynamo for hours, and between the poles of a powerful electro-magnet without any apparent alteration in their vibration, and without any alteration in their rate, either while they were undergoing the tests or after they had been removed from the machine. Although it is quite possible that a current might be used strong enough to stop them, I do not think that it would have any permanent effect, but that the watch would resume its original rate directly it was removed from the influence of the current. The stud, index, jewel settings, and screws have been made of brass, but I do not think this was really necessary, except for appearance; steel ones would probably have no sensible effect. As I found that the palladium springs had a rather greater temperature error than the steel ones, I made some attempts at compensation, but hitherto without success.

### Chinese Children and their Diamonds.

DURING THE morning four children of a rich Chinese merchant, attended by a train of Chinese and Malay servants, came to see Mrs. Shaw. There were a boy and a girl of 5 and 6 years and two younger children. A little description of their appearance reads like fiction. The girl wore a yellow petticoat of treble satin, (mandarin yellow), with broad box-plaits in front and behind, exquisitely embroidered with flowers in shades of blue silk, with narrow box-plaits between, with a trail of blue silk flowers on each. Over this there was a short robe of crimson brocaded silk, with a broad border of cream-white satin, with the same exquisite floral embroidery in shades of blue silk. Above this was a tippet of three rows of embroidered lozenge-shaped "tabs" of satin. The child wore a crown on her head, the basis of which was black vel-



vet. At the top was an aigrette of diamonds of the purest water, the center one as large as a sixpenny piece. Solitaires flashing blue flames blazed all over the cap, and the front was ornamented with a dragon in fine filigree work in red Malay gold set with diamonds. I fear to be thought guilty of exaggeration when I write that this child wore seven necklaces, all of gorgeous beauty. The stones were all cut in facets at the back, and highly polished, and their beauty was enhanced by the good taste and skillful workmanship of the setting. The first necklace was of diamonds set as roses and crescents, some of them very large, and all of great brilliancy; the second of emeralds, a few of which were as large as acorns, but spoiled by being pierced; the third of pearls set whole; the fourth of hollow filigree beads in red, burned gold; the fifth of sapphires and diamonds; the sixth a number of finely-worked chains of gold, with a pendant of a gold filigree fish, set with diamonds; the seventh, what they all wear, a massive gold chain, which looked heavy enough even by itself to weigh down the fragile little wearer, from which depended a gold shield, on which the Chinese characters forming the child's name were raised in rubies, with fishes and flowers in diamonds around it; at the back a god in rubies, similarly surrounded. Magnificent diamond ear rings and heavy gold bracelets completed the display, and all this weight of splendor, valued at the very least at \$40,000, was carried by a frail human mite barely four feet high, with a powdered face, gentle, pensive expression, and quiet grace of manner, who came forward and most winsomely shook hands with us, as did the other grave, gentle mites. They were also loaded with gold and diamonds. Some sugar-plums fell on the floor, and as the eldest girl stooped to pick them up diamond solitaires fell out of her hair, which were gathered up by her attendants as if they were used to such occurrences. Whenever she moved her diamonds flashed, scintillated, and gave forth their blue light. Then came the children of the richest Chinaman in Malacca, but the little creatures were motherless, and mourning for a mother lasts three years, so they were dressed in plain blue and white, and as ornaments wore only very beautiful sapphires and diamonds set in silver.—*The Golden Chersonese—Miss I. L. Bird.*

### Precious Metals in Architecture.

THE Decorative Treatment of Metals in Architecture was the title of a lecture recently delivered in Boston, by Mr. George H. Birch, A. R. I. B. Having explained that he should treat his subject from an art, and not from a constructional, point of view, the lecturer alluded to the immense importance of the metals to man, asking the audience to transport themselves in imagination to the primitive ages, when metallic currency was not, and consider to what straits they would be reduced when chipping the primeval flint or scraping the pre-historic bone. Co-existent with the first germs of civilization, the use of the metals had expanded with its growth, and, from the cradle to the grave, man was absolutely dependent upon the metals for existence. Numberless generations had passed away, but the metals which they fashioned for use or adornment might still exist, albeit melted, remelted and reformed, divided and dispersed infinitesimally, and might continue in existence for countless ages to come.

Taking up, in the first place, the employment of the precious metals, gold and silver, in connection with architecture, we found in Egyptian hieroglyphics many references to their use. The *stèle* of Hatharsa of the twelfth dynasty stated that he compelled chiefs "to wash gold," and on the tablet of Nebuian, in the reign of Thothmes III., we read that, as high priest of Osiris, "I dedicated numerous works in the house of my father, Osiris, of silver and gold. . . . I was called to the house of gold. . . . I made to thee a secret chapel of stone, the bolts on it of brass covered with gold." And in other passages of the same record we were informed that the folding-doors

and the tablets of the temple of Khonsa, in Thebes, were plated with gold, and that the hinges of the gates were of silver, with coverings of gold, while the columns, the cornices and lintels of other temples were referred to as of sandstone, plated with pure gold. Egyptian architecture at the present day showed little trace of any metallic adornment, nor was its use at any time so prevalent there as with the Assyrian, Chaldean, Babylonian, Medo-Persian, and other Semitic races. Gilding was applied by the Egyptians, not as by us, in sheets beaten to an infinitesimal density, but in strips of considerable thickness, as might be seen by an inspection of some of the mummy-cases in the British Museum and the Louvre. In Egypt, sculpture and painting were profusely employed, to the exclusion of other forms of decoration; but many of the obelisks were decorated with gold, both the pyramidon and base being gilded, and they were often surmounted by a disc of gold. The gold mines of Midian were extensively worked by the Egyptians. Captain Burton discovered the cartouche of Rameses III. in some of the disused workings, and the cartouche of a much earlier King Kheper-teara in the Sinaitic peninsula.

The great Assyrian empire was remarkable for its use of the precious metals as architectural adornments. Herodotus told us that the temple built by Nebuchadnezzar at Borsuppa consisted of several stories, diminishing in size, the outer walls of two of these stages being covered with gold and silver respectively; and that at Agbatana, the capital of the Medo-Persian empire, the king's palace had wooden beams, ceilings and pillars covered with plates of gold and silver, and was roofed with silver tiles, and the latter statement was confirmed by Polybius. The temple at Babylon, called by Herodotus that of Jupiter Belus, was also said to be richly decorated with gold.

In the case of the contemporary kingdom of Israel, we knew from the Bible the extensive use made by that purely Semitic race of the precious metals; it being recorded that in the days of Solomon gold was nothing accounted of, and silver in Jerusalem was as the stones of the streets. Even from the time when the children of Israel were journeying in the wilderness they employed the precious metals "borrowed" from the Egyptians in making the sockets, rings, and capitals of the Tabernacle, the columns being overlaid with pure gold—possibly a hyperbolic way of describing plain gilding—and the candle-stick, lamps, and altar of incense being of pure gold. Four hundred and eighty years afterwards a wonderful temple was built by Solomon, of which the chief adornments were metallic. Indeed, one modern manufacturer had gravely attempted to prove that the temple was entirely made of metal, and that no stone was used except for the foundations, basing his belief on the well-known verse (1 Kings, vi. 7) which stated that there was neither hammer nor axe, nor any tool of iron heard in the house while it was building, so that all the parts must have been put together with screws! One might with equal reason start the theory that it was entirely of cedar or other wood, and quote the same chapter as an authority, "as there was no stone seen." Josephus' description of the Temple, although mainly derived from the First Book of Kings, was interesting, as it was interwoven with other traditions; and after allowing for the unintentional love of hyperbole natural to Oriental nations, it was seen that this Temple must have been resplendent with the precious metals, and an object of admiration, wonder and cupidity to other nations. The description of Solomon's palace having roof and walls adorned with gold, gave an accurate idea of those palaces unearthed by Layard at Ninevah and Khorsabad, even to the sculptured lining slabs and ivory thrones. In the biblical account mention was made of Hiram, King of Tyre, who assisted Solomon, especially in making the metal ornaments for which the Jews seemed to have had little aptitude, and from Menander we learned that Hiram also dedicated a golden pillar in the temple of Jupiter at Tyre, and rebuilt the temples of Hercules and Astarte.

The lecturer next referred to the poems of Homer, written apparently about eleven centuries before the Christian era. Homer

described, in language almost sublime, various palaces and halls, such as those he must have seen or heard of, and while affording no idea of their architectural style, he dwelt much upon the golden doors and the silver ornaments, graphically portraying such a wealth of metallic splendor that, to borrow a phrase of his own, his descriptions "poured along like a fire that swept the whole earth before it." In illustration of this vivid imagery, Mr. Birch quoted from Pope's version the well-known descriptions of the Palace of Alcinoüs, and the Hall of Menelaus in Sparta. Doubts had been thrown on the existence of the Homeric heroes, but Dr. Schliemann's discoveries at Mycenæ, Orchomenos, and Hissarlik, of tombs containing immense stores of gold buried with ancient warriors, was striking testimony in confirmation of the poet's story. In a lesser degree we found the same in the tombs of the primitive inhabitants of Italy, the Etruscans, pointing to a common origin, perhaps Pelasgic. Turning back to Greece, we were tempted to ask, as we gazed upon the ruins of the Parthenon or the Athenian Acropolis, could there possibly have been room for any decoration in this temple beyond the perfect symmetry of its own faultless proportion? The answer must be in the affirmative. Not only was color applied, as we saw, beyond power of dispute, in the sculptures by Phidias, now in the British Museum, but metallic decoration also lent its aid in adding to a beauty almost perfect in itself. On the Parthenon were still visible the holes for clamps in the architrave, and circular stains upon the marble, showing that under each of the metopes was suspended a gilded shield, and smaller holes under the triglyphs indicated that inscriptions in gilded letters formerly existed between each. These had been supposed to indicate the votive offerings of shields taken by Alexander from the Persians, and given by him to the Parthenon; but the lecturer believed they formed part of the original design. The acroteria which decorated the mounts and corners of the pediments were also of gilded metal, and the railings or grilles between the columns and the antæ were likewise gilded. Passing within, the most prominent object was the chryselephantine statue by Phidias, in which the glittering golden raiment and crested helm contrasted with the soft creamy beauty of ivory flesh. We knew that the temples of Jupiter at Olympia, and of Apollo at Delphi were also full to overflowing with the votive offerings of generations. The inner sanctuary of Herod's Temple at Jerusalem was decorated with a golden vine; indeed, so immense was the quantity of gold in this temple that after the destruction of Jerusalem gold was sold in Syria, by the soldiers of Titus, for half its value.

Passing on to Imperial Rome, one was almost bewildered by the many examples of the employment of the precious metals in the adornment of its edifices, such as the Golden House of Nero, the gilded Capitol, the Temple of Ceres, and the gilded statues and trophies of the Ulphian Basilica. In the New Rome, on the banks of the Bosphorus, the same traditions as to the use of the precious metals were maintained. The Church of St. Sophia must, in the days of its first magnificence, have been refulgent with the precious metals; apart from the universal use of gold and silver mosaics in its dome and vaults, the columns of the ciborium and the baldachino over the altar were formed of silver-gilt; the sculptured lilies and fruits which adorned it, and the cross which surmounted it, were of solid gold; and of gold were also the solea and ambones. At the Church of the Resurrection, in the same city, the under side of its wooden vault was covered with plates of gold by Basil, the Macedonian. In the Church of St. Demetrius, at Thessalonica, A.D. 458, there was a ciborium of silver, and the shrine of the saint was hexagonal; both the six columns and the walls being of silver, covered with incised ornament, and the circular cover and the sphere and cross above were also of silver. This seemed to have been the prototype of many of the gorgeous shrines of Mediæval churches. The three immense basilicas at Rome:—St. Peter, St. John Lateran, and St. Paul-without-the-Walls, were rich in the precious metals. In some of the Italian churches, and also in Spain and Germany, were still preserved magnificent altar-pieces of silver-gilt, called *pala d'oro*.

In St. Mark's, Venice, was a superb specimen which was uncovered on great festivals; it was of Byzantine workmanship, and richly jeweled; it was made in 976 by order of the Doge Pietro Orseolo, but was much altered by successive Doges. St. Ambrose's Church, Milan, possessed one of the richest in Christendom, and slightly earlier (A.D. 835) than the Venetian one. The front was of gold, and the sides and back of silver; it was richly enameled and set with jewels. The name of the artist had been preserved, Wolvernus. In the Duomo at Monza, was an altar-frontal silver-gilt, of the tenth century, and at Citta di Castello, a silver altar-piece of the twelfth century. A magnificent *pala d'oro*, formerly in the Cathedral of Bale, now formed one of the chief treasures of the museum at the Hôtel Cluny, Paris. It was given to the cathedral by the Emperor, Henry III., about the commencement of the eleventh century, and, although betraying Greek influence, was probably of Lombardice, and not Byzantine workmanship. It was of solid gold, on a foundation of cedar, and was remarkable for the life-like energy of the figures in high relief, and exquisite workmanship of the foliage, animals, and filigree enrichments. The tomb of St. Margaret, in the church of the same name at Cortona, was of the thirteenth century, and had a silver front. At Florence, in the Opera del Duomo, was preserved a silver retable beautifully enameled; it was five feet high, fifteen feet long, and was divided into twelve compartments, and in the center was a figure of St. John. Begun in 1366, it was not finished till 1477, and Ghiberti, Orcagna, Verrochio, and other artists worked upon it. In the present day gold and silver were far too precious to be used except in ordinary currency; in Europe alone it was estimated that these metals were employed for this purpose to the extent of over two thousand billion sterling—or in small objects of use or ornament.

---

### The Tempering and Annealing of Steel.

WE COLLECT under this title the results of experiences, says the *Journal Suisse d'Horlogerie*, which we have gathered on the method of tempering and annealing steel, and of the agents proper to be used for this purpose. We first have the composition of the mixture of M. Raoul, of Paris, for hardening his world-renowned files:

- 906 grams mutton suet, not prepared, but simply cut in pieces.
- 906 grams bacon.
- 56 grams pulverized white arsenic.

This mixture, cut into an iron pot, is left to boil until a handful of freshly-gathered hawkweed (*hieracium piloselle*) which has been placed with the mixture near the fire, has curled up and swims on the surface of the fluid, which proves that the entire humidity has disappeared.

This work as well as the hardening of the files must be performed under the flue of a smithy, in order to avoid as much as possible the arsenious vapors; besides this, the workman must close very effectively both mouth and nostrils, so as not to breathe these noxious emanations.

After repeated experiments with English files of every size and sort, chosen from among the best and hardest, all were attacked by the Raoul's files, and the superiority of the latter is thereby established.

When tempering razors and cutting instruments, it is necessary to thoroughly free the steel from the crust formed by forging; by this precautionary rule a very high degree of temper can be imparted, and that with a degree of heat inferior to that necessary if said rule had not been observed, because the hardening operates stronger and more uniformly on the bright steel than on the crust.

The following process, which has been acknowledged to be the

best for hardening cutting tools by a skillful workman of Sheffield, is described as follows by his employer, M. Stoddard: Since said workman has mixed leather cuttings among his charcoal, he has not had a single crack in his razors, while he often had them formerly.

The cause of these cracks, which frequently appear upon the surface of hardened bodies, may be explained in the following manner:

It is known that soft steel increases its volume when it is hardened, and it is easy to arrive at the conclusion that the steel is less dense in proportion as it approaches the condition of iron. If, therefore, a piece of steel is heated in the open fire and an air current is passed over it, then the outer part of the metal, in consequence of its decarburization partakes less of the nature of steel than formerly; thence follows that the interior part of the article, compared to the outer, becomes too large, and the workman is consequently exposed to the danger to see it burst. But when the piece is surrounded with a mixture suitable for effecting cementation, or exposed to a fire, which may also operate with a steel-forming effect, containing animal charcoal, then the opposite phenomenon will result. The outer part, instead of being decarbonized by the fire, becomes richer in carbon than the inner portion; in consequence of which, in place of cracking during the cooling, it will become harder and more dense.

The cracks which often appear when steel is dipped into water, do not always seem to be due to a simple decarburization of the surface, but they may be owing to the sudden contraction which the latter experiences; while the interior portion remains expanded by the heat, and retains its increase of volume for another moment, after the exterior has been brought in contact with the water.

The above described method may be followed for the hardening of stamps and matrices, similar as for dies, but remembering their fragility and delicacy, they are to be annealed pale yellow, even violet.

We have received valuable data from one of our subscribers, who is an adept in hardening and annealing steel, and they confirm to a certain extent the foregoing remarks.

When punches are to be hardened, which are for the purpose of being driven in steel matrices, they must be heated until annealed blue, then rub them with the fatty part of a beef sinew, until covered with a thick coat, which excludes the air from the steel, and conveys to it carbon, instead of withdrawing it. For the same purpose, either small pieces of carpet or wool are to be laid upon the fire. The gases covering the body are permitted to develop fully, and when it has become sufficiently cherry-red, it is dipped into old water, which has previously been boiled and cooled again.

The punches are pickled by dropping upon their surface a drop of muriatic acid; they are then rubbed off with a brush, washed, and anointed with fat. When fairly clean and without flaws, they are annealed pale yellow, and they then possess sufficient hardness to be driven cold into softened steel.

For the purpose of softening the steel, a well-closing little sheet-iron box is necessary; upon its bottom is spread a good layer of charcoal dust, which should not be too fine, however; an occasional little piece is advantageous, as it facilitates the circulation of the gases; upon this stratum is laid the steel, which again is covered with coal dust. The box is then wrapped around with strong iron wire, and again enveloped in coal dust; it is now heated for at least two hours in a furnace fed with charcoal. Great care is to be exercised not to have any coke in the coal, because this contains sulphur, which would harden the steel. After the lapse of this time cease feeding the fire, and let it cool off slowly by excluding air, which might penetrate into the box. This gradual cooling and protection against contact with the atmosphere softens the steel.

It is easy to see whether the process has been successful; it can be recognized by the outward color of the punches; when worked, they will remain white, and when unworked, they will be of a gray color, and be soft under the file.

## Gossip From Providence.

[From Our Own Correspondent.]

**B**USINESS here continues very dull. The majority of the factories are running only eight hours a day, and with about half the usual number of hands at that. As a natural consequence there are many working jewelers out of employment. A gentleman who recently advertised for a coachman told me last week that among the applications he received for the position, nine were from jewelers. The reports from travelers on the road are also very discouraging. The jobbers, they say, will buy only in the merest sample lines, and in many instances decline even to look at goods. If sales be bad, collections are a great deal worse. The leading houses say that they never experienced such a hard time in this respect, and many of the smaller and weaker concerns are in consequence very much cramped.

My prognostication as to credit in a former letter is fully borne out by existing conditions. The best firms are exercising great caution in filling orders, and if there be any cause for suspicion they decline to sell save for cash. The recent failures in the trade, coupled with the bad showing made to the creditors, has caused much unfavorable comment, and tends largely to augment the existing feeling of despondency and suspicion. How to prevent the recurrences of these financial fiascos is a problem much under discussion at the present time. The remedy appears to me very simple provided that unanimity of action can be obtained. Let the New England Manufacturing Jewelers' Association take the matter up and appoint a committee to investigate all cases of failure in which members are interested, and where there is fair cause to suspect fraud or unfair dealing, let them black-list the party so suspected, and let it be binding upon the members of the association not to sell any person or firm so black-listed even for cash. This course would drive out of business all the dishonest harpies who prey upon the manufacturers, would inaugurate a new field of usefulness for the association, largely increase its membership, and give the best class of the wholesale dealers a better chance. Nothing in my opinion can be more unfair than when a man fails, (preferring "His sisters, his cousins, and his aunts" to the extent of all his available assets), to accept a compromise of from 10 per cent. to 25 per cent., and then go on selling him again. How can the honest wholesale dealer expect to compete successfully with a man who can afford to sell say at 50 per cent. less than he can? This is a matter for serious consideration, and the sooner some stringent action is taken the better it will be both for manufacturers and jobbers.

The following circular has been printed and circulated extensively among the manufacturers here:

### TO THE JOBBING JEWELERS.

THE OTHER SIDE.

*Editors Watchmaker and Metalworker:*

The article in your July number headed "Very Important" appears to me to be clear off. The jobbers have no reason to complain of the Eastern manufacturers selling to retail trade, as they have brought this state of affairs about themselves, and in this way:

1st. They come into the market, look over the different lines, get prices, and go from one manufacturer to the other quoting each other's prices, or a little less than the irprices, in order to beat them down.

2d. When they have bought their goods, and the bill has run from six to nine months, they will send their note at from three to six months in payment, not forgetting to deduct the cash discount.

3d. At the end of the season, if they have a few goods left in stock which they don't wish to carry another season, back they go to the manufacturer.

Now, the manufacturers have got tired of this kind of business, and unless the jobbers change their way of dealing with them, in a few years there will be no jobbers, as each year the manufacturers grow more and more determined not to be bulldozed. If the jobbers want the manufacturers to let the retail trade alone, they must give us a fair profit and fair dealing.

A MANUFACTURER.

Providence, R. I.

The usual monthly meeting of the New England Manufacturing Jewelers' Association was held at their rooms on Saturday, Sept. 6, 1884. The President, Mr. Potter, called the meeting to order at 8 P. M. The records of the last meeting were read by the Secretary, and approved. An Entertainment Committee made up of the following gentlemen was appointed for the coming season: Messrs. O. C. Devereux, W. Dodge, F. Pearce, H. F. Carpenter and J. S. Haskell. There was no other business transacted. ASMODEUS. Providence, R. I., Sept. 15, 1884.

## A Review of the Experiments of the Old Masters of Horology.

*Continued from page 251.*

WE NEXT quote the opinions of another celebrated master of horology, Mr. J. H. Martens, on the manufacture of a compensation balance, which we borrow from his excellent work: "The escapements of higher horology." Martens at first contradicts the assertions of Mr. Jürgensen, and says:

In the construction of compensation balances two methods are made use of for joining the two metals of which the compensating rim is to be formed. The first consists in soldering together the brass and steel with silver solder, and the second by melting the brass around the steel. The first method is not by any means practical, since in the soldering of an object like the present, the solder will not divide equally because the brass ring, which is at first to be forced around the steel, will expand far more by the heat necessary for the process than the steel, and when said brass ring cools more solder will remain upon one side than upon the other. Furthermore, spots will be found in the hoop where the brass and steel have not become intimately united by the silver solder, which defect becomes visible, especially when the brass is to be hardened by hammering. The method, by which the brass is melted around the steel is preferable, and I will therefore explain the latter.

First glow-heat the steel and let it cool slowly; then file one side flat and cement the piece to a chuck of the lathe, turn it in the shape shown in fig. 10; at the same time drill a hole in the center, and in order to have it very true turn it out to a fitting size. The lower rim, shown in fig. 10, which remains standing, is to be left 0.2 mm. thick. In order to ascertain the exact size for the high part, it is necessary to first establish the diameter of the balance, that is, that of the rim, and the thickness of the latter. When the diameter and the height of the balance have been definitely established, the thickness and size of the rim is to be ascertained, to be done as follows:

Let us assume, for instance, that a balance of 20 mm. diameter is to be made, then the thickness of the rim to the diameter of the balance is proportioned as 0.3 is to 10; consequently the thickness of the rim will have to be 0.6 mm., with a diameter of balance of 20 mm. This thickness is for the two metals (steel and brass), and it is necessary next to divide it properly for both, which we do according to the following rules:

We assume the entire thickness of the rim =  $\frac{5}{8}$ , of which we take  $\frac{2}{5}$  for the steel and  $\frac{3}{5}$  for the brass, and the latter having a rim of 0.6 mm. thick must be 0.36 mm. We next must deduct the height intended for the screws from the diameter of the balance. When, for instance, the height of the screws for this size of balance (20 mm.) is to be 1.2 mm., then this number taken twice = 2.4 mm., to be deducted from the diameter (= 20 mm.), and there remains 17.6 mm. for the exterior diameter of the rim. From this we deduct the quantity for the brass parts 0.36 mm. twice (= 0.72 mm.), and we

find for the steel a diameter of = 16.88 mm. After having turned the elevated part of the steel exactly according to these proportions, and a little higher than the balance is to be, take the blank from the lathe and clean off any adhering cement. Next make the preparations necessary for casting. For this purpose prepare a sheet iron hoop about twice the height of the turned steel blank and sufficiently large to embrace it entirely, then fasten it with soft binding wire around the blank. See fig. 11, in which the hoop is marked with *g*.

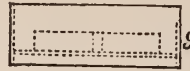

FIG. 11.

In order to protect the hole from being filled with the melted brass, tightly drive in a basswood plug. This basswood will be charred into a hard coal by the fusing metal and prevent it from running into the hole. In place of wood equal parts of pulverized graphite and slate, kneaded with water into a thick paste, may be used and pressed tightly into the hole. For greater security make still another elevation of this paste above the hole and let it stand out a little all around, and press it firm all around upon the blank. Next prepare a similar paste of clay and water, and lute the lower face thus that even the smallest openings are closed between hoop and blank and let everything dry slowly. This mold is laid upon a metal sheet and slightly heated above an alcohol flame; then moisten the interior with water in which borax has been dissolved, using a small brush or feather for the purpose; let the borax effervesce by the heat, and be careful to have especially the circumference of the blank, with which the brass is to unite, uniformly coated with the borax. Having advanced so far with your preparations, fill in the entire space up to the upper edge of the hoop with powdered borax, (which, however, must previously be melted in a crucible to prevent too violent an effervescence), place a sufficient quantity of small pieces of fine brass upon the borax, expose the whole to a proper heat so that the brass comes into the rough fusion and runs around the rim of the steel blank and intimately unites with it.

The heat necessary for fusing may also be produced between two large pieces of charcoal, with an alcohol flame and a blowpipe.

It stands to reason that for a large balance the heat produced in this manner is not sufficient, and in this case make a well drawing fire and place the mold upon a firm underlay of stone or iron. When using such a fire, however, great attention is to be paid that the heat does not become too strong either upon one side or the other, because the steel might easily be burned thereby. When the fusion has been effected let everything cool well, clean off the adhering borax, file off the hoop and again cement the piece with its lower surface to the chuck, turn down the brass level to the upper face of the steel, turn the blank over on the other side and cement it with the turned-down face to the chuck. Next turn off sufficient of the lower face to lay bare the brass, and at the same time turn away from the brass rim so much that it remains three times as thick as it is to be when ready. Now, glow-heat the blank cautiously and let it cool off slowly. When cold hammer the brass carefully with very regular taps upon the high edge of the balance. When the blank has been treated twice all around in this manner, file off the brass that spread over the sides and anneal the blank blue. Again hammer the brass in the same manner once more but be careful to do it uniformly all around, and that the blows do not penetrate into the steel so as not to alter its roundness. When the brass has been hammered into about one-half of its original thickness, and if no open flaws have been revealed during the operation between steel and brass, that portion of the latter which spread over the sides is to be filed away, and the blank is to be again annealed blue.

Cement the blank again to the lathe chuck and turn it down to the size required for the balance, that is, that it will be of the correct diameter after the brass has been ground off smooth. Next proceed to the turning out in the steel, in which operation both rim and bottom have to be left a little thicker than they are to be in a ready condition (the bottom for a balance of 20 mm. diameter has to have a thickness of 0.4 mm.) When the turning out is finished

from one side, or, should the shape of the balance under manipulation require it, from both sides, grind them out first with a round disc of soft steel and fine emery and oil, until all turning marks have disappeared, and next with a full hard disc and oilstone powder moistened with oil until the bottom is ground entirely smooth. The first disc of those used must be much smaller than the inner space of the turning out of the balance, and be filed flat very often because the face will become untrue in grinding. The second disc, however, which must be hard, is only to be a trifle smaller than the inner turning out. When the height of the rim has been set in order, the holes for the screws are to be drilled in. For this purpose a chuck must have been made for the lathe, the spindle of which is provided with a graduation as shown in fig. 12. In this chuck is fastened a

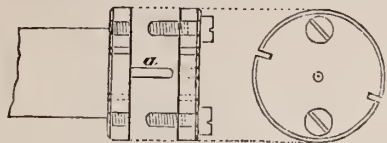

FIG. 12.

pin *a*, which is turned off truly and of sufficient thickness that it fits full tight in the balance hole. Now, upon this pin *a* the balance (in the bottom of which two holes are to be drilled for the screws of the covering plate of the chuck), is to be mounted and fastened by means of the covering plate and the two screws. (The chuck must be a little smaller in diameter than the size intended for the balance). Next, the rim is to be laid off for the screw holes and the holes drilled. For want of a graduated scale on the lathe the division has to be made on a cutter and rounder or other contrivance provided with a graduation. The arms are next to be made and the screw threads cut into the holes. If weights are to be made for the regulating of the compensation, then upon the lower high edge a part of the rim, on each side between the arms, is to be provided with a division. When this has been done a boxwood chuck is to be made for the latter, as shown in fig. 13. Into this chuck is turned a sink of the size of the balance, and of such a depth that when the balance is pressed in the one-half or one-third of its height projects beyond the chuck, as will be seen by the same figure. The arms are then again to be ground with a hardened flat steel disc and finely powdered oilstone, carefully keeping the disc flat so that the arms will not lose their flatness. When satisfied that the arms are duly flat and ground smooth, take good strong elderberry pith, cut one end flat, put a little oilstone powder and oil on it and apply the pith very flat upon the arms, but let the balance in this work revolve only a few times while moving the elderberry pith slowly to and fro. A very handsome mat white finish is produced hereby. Progressing, chamfer the sharp edges of the rim, polish them, and grind also the face of the high edge with a glass plate and finely-ground oilstone. But if the surface is to be polished it is effected best by means of a sheet of tin upon which a little fine rouge is put. When the work has advanced this far, take the balance out of the wooden chuck, clean it carefully and again fasten it in the chuck (fig. 12), next grind the rim above with a tin file and finely-scraped waterstone and oil, and if it is to be polished on top, clean it first very carefully and polish it next with a well rubbed burnishing steel, exercising great care when bearing upon the latter.

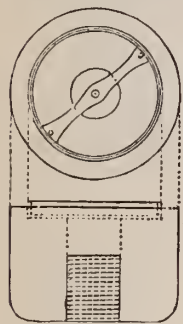

FIG. 13.

After burnishing, take a fraise and open the rim on two places in the vicinity of the arms (the two notches in fig. 12 cut into the chuck are made for this purpose), chamfer the two edges of the cut and make the rim truly round. In this operation only plyers with wood-lined jaws must be employed, so as not to injure the brass part of the rim.

The regulating screws are to be made next. The necessary little steel screws upon which they are to be fastened are screwed from

the inside into the rim, and the regulating screws screwed upon these. It has previously been mentioned that these regulating screws must always move with hard friction upon the small steel screws, and it is advisable, therefore, to cut them open on one side and to press them together a little. The weights that are to be used for the regulating of the composition, are also made now in the following manner:

After filing flat the pieces to be used for this purpose on their end, take a sheet of brass 2 or 3 mm. thick, and with compasses strike upon it a circle of the size described by the wings of the balance; solder the pieces with tin upon the plate so that the center of the pieces comes exactly above the circle, cement the piece on a lathe chuck, and finally turn in a groove of the size of the wings. When this has been done, turn the pieces both inside and outside so that they are of an equal thickness, take down the plate from the chuck, and unsolder the pieces, after which you may give them any shape you desire. Before finishing them altogether examine them as to their equipoise, adjust this and then finish them, after which they are to be fastened upon the balance wings with little screws.

Figs. 14, 15 and 16 is a compensation balance taken from the said work of Martens. The first two are top and bottom views, the

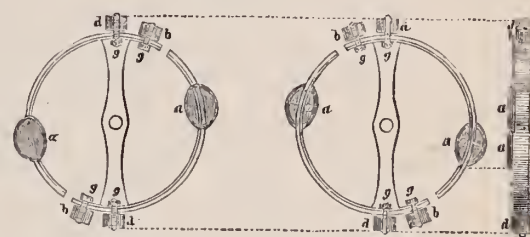

FIG. 14.

FIG. 15.

FIG. 16.

third is a side view. The weights *a* are those used for the regulating of the compensation; *b* and *d* are the screws for more closely regulating the vibrations of the balance, which are movable, and fastened in such a manner that they fit tight to prevent them from being displaced by the vibrations of the balance. When the balance vibrates slowly they approach its center; when rapidly, they remove from it.

*d.* LOSEBY'S COMPENSATED CHRONOMETER BALANCE.

Loseby specified as defect of the ordinary compensated balance that even if a chronometer has been perfectly regulated to the extremest changes of temperature it is nevertheless very difficult to obtain a correct rate for the intermediate degrees of temperatures, because the elasticity of the balance spring decreases at a ratio greater than the effect produced by the less metallic compensation strip composing the balance, and he believes to have successfully corrected this defect by the introduction of carved glass tubes filled with mercury and attached to the balance, which are constructed in such a manner that while the mercury expands by reason of change of temperature, the quicksilver, and consequently also the point of vibration, will in a gradually increasing degree approach to the balance axis.

Fig. 17 gives the surface view, fig. 18 the side view of such a com-

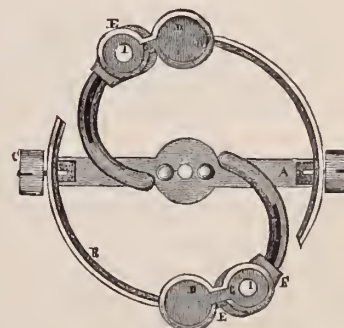

FIG. 17.

pensated balance. With the balance arm *A* are united, by the regulating screws *C C*, the bi-metallic compensated ring pieces *B B*; *D D* are the weights for regulating the ordinary compensation, *E E*

the glass compensation tubes added by Loseby; *FF* and *GG* are the parts through which these tubes are fastened to the balance.



FIG. 18.

The screws *II* serve for connecting the parts *F* and *G*; these screws also permit the adjustment of the auxiliary compensation by turning inward or outward the tubes.

(To be continued.)

### The Jewelers' Security Alliance.

President, DAVID C. DODD, JR.

Vice-President, AUGUSTUS K. SLOAN.....Of Carter, Sloan & Co.  
Treasurer, W. C. KIMBALL.....Of H. F. Barrows & Co.  
Secretary, C. C. Champenois.....Of Champenois & Co.

#### EXECUTIVE COMMITTEE.

C. G. ALFORD, *Chairman*.....Of C. G. Alford & Co.  
C. B. BISHOP.....Of Carrow, Bishop & Co.  
HENRY HAYES.....Of Wheeler, Parsons & Hayes.  
J. B. BOWDEN.....Of J. B. Bowden & Co.  
DAVID UNTERMAYER.....Of Keller & Untermeyer.  
E. F. DORRANCE.....Of Dorrance & Brother.

P. O. Box 3277.

Room 2, 170 Broadway, New York.

HON. ALGERNON S. SULLIVAN, *Counsel*.

AT A MEETING of the Executive Committee held at the office of the Alliance, 170 Broadway, on the 12th inst., the following applicants were admitted to membership, viz.:

N. J. Battershell, Heyworth, Ill.; Bullard Bros., St. Paul, Minn.; S. H. Dodge, Ypsilanti, Mich.; Henry Greenman, Richfield Springs, N. Y.; J. Gansl, Tuscaloosa, Ala.; S. Hecht, Wichita, Kansas; C. Hulse & Son, Goshen, N. Y.; Everett Lane, Gloucester, Mass.; A. G. Page, Jr., Bath, Me.; A. Shire, Paris, Ky.

### The Jewelers' League.

President, GILBERT T. WOGLOM.....Of Woglom & Miller.  
First Vice-President, WM. C. KIMBALL.....Of H. F. Barrows & Co.  
Second Vice-President, AUG. KURTZBORN.....Of L. Bauman Jewelry Co. St. Louis, Mo.  
Third Vice-President, JAMES P. SNOW.....Of G. & S. Owen & Co.  
Fourth Vice-President, HENRY HAYES.....Of Wheeler, Parsons & Hayes.  
Secretary and Treasurer, WILLIAM L. SEXTON.....Of Sexton & Cole.

#### EXECUTIVE COMMITTEE.

ROBERT A. JOHNSON, *Chairman*.....Of Colby & Johnson.  
SAMUEL W. SAXTON.....Of Saxton, Smith & Co.  
CLEMENT B. BISHOP.....Of Carrow, Bishop & Co.  
JOSEPH B. BOWDEN.....Of J. B. Bowden & Co.  
GEORGE R. HOWE.....Of Carter, Sloan & Co.  
CHARLES G. LEWIS.....Of Randel, Baremore & Billings.

THE JEWELERS' CIRCULAR is the *exclusive* official paper of the Jewelers' League, and has been selected for the publication of all matters of interest pertaining thereto. Letters or inquiries pertinent to its business or purposes, and which might interest the trade or inquirers, will herein be answered. Address *Jewelers' League*, Box 3,444, P. O., New York, or the office of THE CIRCULAR.

THE REGULAR meeting of the Executive Committee was held on Sept. 5th, 1884. There were present Vice-President Kimball and Messrs. R. A. Johnson, (Chairman), G. R. Howe, J. B. Bowden, C. G. Lewis and W. L. Sexton.

Owing to the deaths of P. J. Elinquist, Morris, Minnesota, Monroe Marx, New York City, F. A. Cady, Charleston, S. C., E. D. Rhodes, North Attleboro, Mass., D. H. Hopkinson, Brooklyn, N. Y., an assessment of \$10 was ordered.

There is but one other death known of, that of Philip Nast, of Nast & Greensweig, N. Y. City. The proof of his death not yet

being presented, it was impossible to include it in the present assessment.

There were 14 changes of beneficiaries granted.

Nine applications were referred for correction.

One application was rejected.

The following 18 applicants were admitted to membership:

N. D. Prentiss, H. W. Souade, F. J. Bejborn, New York City, N. Y.; J. O. Thurston, Brooklyn, N. Y.; J. F. Jarvis, Jr., Mt. Vernon, N. Y.; J. W. Forsinger, E. E. Wilkinson, Chicago, Ill.; A. T. Westlake, Springfield, Ill.; F. G. Thearle, Englewood, Ill.; E. DeF. Wilkinson, Providence, R. I.; E. G. Pearson, Boston, Mass.; F. Scott, Carthage, Mo.; S. Joseph, Des Moines, Iowa; H. F. Schmidt, Terre Haute, Ind.; R. J. Tafel, Louisville, Ky.; F. R. Herz, Virginia, Nev.; W. Thoustrup, San Francisco, Cal.; H. T. Hollingworth, Santa Ana, Cal.

### Advice to Watchmakers' Apprentices.

BY A MAN WHO HAS SPENT TWENTY YEARS AT THE BENCH.

IN MY last communication I gave some hints in regard to economizing the sweepings, and gave directions for burning the sweepings to diminish the bulk; I ought to have added that the fire should be a smouldering one, with as little direct draft as possible, as a strong flame has a tendency to carry more or less gold up the chimney. The safest and most economical method is to put the sweep into an iron pot, with an iron cover, and put the pot into the furnace and burn the contents out by a slow combustion. But, if the process is conducted as directed in last article with the precaution of making the combustion as slow as possible, very little gold will be lost. The acids used in coloring and pickling should not be thrown away until treated to recover the gold. All wet coloring acids and muriatic acid pickle after using should be thrown into a stoneware jar and when nearly full treated as follows: A saturated solution of green copperas (*proto-sulphate of iron*), in the proportion of 8 oz. of hot water to 1 oz. of the sulphate. In getting the sulphate it is best to get such as is used for medicinal and chemical purposes, as it is essential to be pure; also avoid all such pieces as are air slacked or present the look of rusty iron; such pieces are chemically changed to such an extent as to be deliterious to the process. The solution of sulphate should be added to the acids in the stoneware vessel until it fails to produce any effect. Allow the precipitate to settle (after stirring well) when the acid can be poured off. The precipitate is nearly pure gold, and if of sufficient quantity can be directly recovered by melting with a strong flux. By a strong flux I mean one which will resist a high temperature, as the complete reduction of the gold will require intense heat. After the precipitate is thoroughly dried, to every 4 oz. of precipitate add 2 oz. of sal tartar (*carbonate of potash*), 1 oz. of common salt, 1 oz. of green glass (any glass which contains no lead). All the ingredients should be reduced to a fine powder and well mixed, when it can be put in a crucible. While the melting is going on a little saltpeter can be added occasionally to aid the process. But in small quantities the precipitate can be thrown into the burnt sweep; as also the old sulphuric acid pickle used in jobbing. The true course to pursue as far as scouring is concerned, is to look sharp to all the filings of gold on plated jobs. There is more gold wasted here than in any part of the job shop. And as I remarked in a former communication, the gold derived from filings seldom or never works well; and for this reason it is best to melt it into a button, so as to get at the fineness and sell it to the refiner. The best course to pursue with filings ("*lemel*," it is termed), is to first pass it through a fine sieve to remove all pieces of gold of any size; these should be put in with the scrap. After all the coarse particles of gold and silver are removed, the magnet should again be employed to remove any iron or steel particles which may remain. In refining and melting filings, for every 12 oz. of filing take 2 oz. of sal tartar

(carbonate of potash) 1 oz. of common salt. Mix the filings and flux together well, and put them into a crucible and cover the mixture with common salt. The crucible should now be put into the furnace and a continual high melting heat kept up for 30 or 40 minutes, adding a little saltpeter from time to time. Care must be taken to add the saltpeter sparingly as it may cause the mixture to rise and flow over. A little very dry common salt if added, as indications of rising too high occur, will check it. I will now give a few hints about enameling. This beautiful art is an immense addition to the splendor of gold goods, but I would premise by saying that enameling is a trade by itself, and it is hardly to be hoped that in the sense in which these articles are written that a man could practice the jewelers' art and the enamellers' both in a high degree of excellence. It is quite easy for a jeweler who is at all skillful with the graver to prepare his work so that all the enamer has to do is to fill in the cutting, leaving it for him (the jeweler) to finish by grinding and polishing. We will first discuss the manner of engraving for enameling. The *rationale* of the process is that a sink or recess is made in the gold or other metal to be enameled of sufficient depth and form to contain a layer of colored glass, which will polish off and leave a surface exactly corresponding with the surface of the gold. Suppose we have an initial we wish to enamel. By means of flat bottom gravers we cut away the gold to such a depth as will enable us to fill the recessed attic with enamel. A good deal of judgment is required in the engraving so as to get the best results. We will first speak of enameling done with opaque colors. The engraving should be of sufficient depth to ensure a firm coating, yet the cutting should not be carried to a depth sufficient to weaken the metal or to form pools as it were of glass. The cutting should be of equal depth throughout; generally  $\frac{1}{100}$  of an inch will be about right. The edges of the recess should be as near vertical as possible. An illustration is given at Fig. 1 of an initial say of white



enamel; *b b* is a vertical section of the letter on the line *a a*. This shows the broad lines or sinks of equal depth as well as of the hair line. On the line *d d* are shown a shallow gothic-shaped recess. The reader will see that this sort of recess would not enamel satisfactorily, as it is evident that the gold would show through the edge as at the dotted line *c*; and further, it is evident that when the surface comes to be ground and polished to finish the enamel, that the margin of the letter or other design would be irregular. Consequently all parts which are to show a bright metal surface should be cut so as to leave a sharp clear edge, even in small lines, as illustrated in fig. 2, which is copied directly from a fair specimen of Swiss (Geneva) enameling. This cut (fig. 2) gives a sample of encrusting with rose diamonds. It is difficult to give with a simple black and white engraving the effect of the colors and the diamonds. To describe it, the background to the extent of the dark space enclosed in the outer ring or line is a dark blue enamel, but sufficiently transparent to show a geometric lathe pattern through it. The bird was produced almost entirely of gold with diamonds set as shown, the lines in the wings were cut in and filled with the blue enamel of the ground, but looked quite black by contrast when in fine lines. The flowers below the bird were of white enamel, but with a bright gold line surrounding each petal.

Indeed the whole pattern or design was made out as if outlined with gold wire. The vine in front and over the bird was a bright gold line, and the three leaves were outlined with gold and filled with emerald green enamel. In engraving for this job, of course, all the parts which show black had to be recessed back evenly to the depth of about  $\frac{1}{100}$  of an inch, and filled in with the different enamels, and these enamels fused to make them flow. The filling must be in excess so that a smooth, even surface can be produced by polishing.

## The History of Goldsmithing.

*Continued from Page 232.*

THESE DIFFERENCES of taste were noticeable even in the works of the goldsmith. During the centuries of greatest sumptuousness, when the art of goldsmithing was at its height, gold and silver were hardly ever employed, except in a pure state, and fine stones were also added after a while to heighten both the effect and the value of the piece. But after a time this no longer satisfied the cravings after novelties of the Lower Empire—the goldsmith was required to produce something startling, and he had recourse to embellishing gold and silver surfaces with the brightest of colors, and in this manner he employed a device hitherto entirely unknown to his Greek and Roman predecessors. Not alone were jewels and fine stones employed in great profusion, together with pearls and cameos, but by this grasping after effects and novelty, the Byzantine goldsmith also discovered a means of enhancing the beauty of less costly surfaces with colored glass, and thus the first step toward the art of enameling was made.

The enamel first used by the Byzantines is nothing else than a glassy substance applied upon the surface of the metal, and fixed by means of fusion; the different colors are generally separated by a low partition, which style has retained its French name in all languages, to wit, *cloison*; *cloisonnage*; these partitions serve a double purpose. They separate the colors and clearly define the pattern. The colors of the Byzantine enamel generally are of great vivacity and have the further advantage of being perfectly inalterable.

It is, perhaps, useless to ask the question from whom did the Byzantines learn this industry? It was most probably an invention of their own, because it appears that it was unknown to the ancients, except a slight film which the latter applied in an adroit manner by means of the blow-pipe upon trinkets of personal adornment. The Byzantine art of enameling rapidly spread upon the continent, and it is most probable that it became universal in the time of Justinian, in the sixth century, in which opinion we are sustained by the following passage of a contemporaneous poet, Corippus, who celebrates the pomp and circumstance of the Imperial court:

“On a table covered with purple,” says our historian, “could be seen vessels of gold, the weight of which was greatly enhanced by the profusion of precious stones. The portrait of Justinian was painted upon all the pieces. . . .” And further on: “The Emperor had ordered that the history of his triumphs should be traced upon each piece of his dishes.”

And in effect, enameling, which can be used for the representation of all kinds of subjects, was a veritable branch of art painting in the hands of the goldsmith. Thus it came that during several centuries figures either sacred or profane, those of Christ and his holy mother, of the Evangelists, of the apostles and the principal saints of the Oriental Church, those of the Emperors, their wives or princes of the empire, were re-produced *ad infinitum*. As specimens of the paintings of this kind we give the accompanying, figure 9, of St. Procopius and St. George, taken from a small enameled plate in the art collection of St. Mark in Venice.

But the time arrived when the adoration of images, and shortly afterward the re-production of the human figure in all the ramifications of religious service was forbidden by the Church of the

Orient. This schism, known by the name of the schism of the *Iconoclastes*, and which lasted about a century, gave rise to rigorous prosecutions. It struck a severe blow to the art. Among other consequences it caused a large number of Byzantine artists to emigrate; they carried with them first into Italy, from there into the rest of Europe, the arts and industries of their country, of which they had hitherto enjoyed the monopoly.



FIG. 9.

It would disarrange the order of chronology, which we intend to observe in this History of Goldsmithing, were we to follow the fortunes simply of Byzantine goldsmithing. This much, however, we may add, that it continued to prosper even under the severe government of the *Iconoclastes*, and found powerful protectors

such as the Emperor Basil I., the Macedonian, in the ninth century, and, in the tenth, Constantine Porphyrogenitus, who is renowned as having himself been one of the foremost artists of his age.

In the foregoing pages we have sought to show that the art of the goldsmith descended from the earliest antiquity to later civilized nations; it remains for us next to inquire into the state in which it was developed among the barbarians. This will be the object of the following chapter.

#### b. GOLDSMITHING AMONG THE BARBARIANS.

The barbarians, in times of yore so often vanquished by Rome, took, in the first centuries of our era, a terrible revenge on what once was called the "Roman World."

Whence came they? No one can answer the question.

From the north and the east of Europe, from the extremes of Asia, issued an incessant avalanche of nomadic people, uniting and overrunning every country in Europe which might in the least tempt their cupidity. They were the Huns, the Vandals, the Goths, afterward divided into Ostrogoths and Visigoths; the Lombards, the Franks, the Saxons, the Burgundians, who issued from the forests of Germany; the Danes, the Normans, and other pirates of the North of whom innumerable hordes overran in turn, Gaul, Great Britain, Spain and even Italy, where they carried terror into Rome.

The barbarian state differs from the savage in that while with the latter there is an utter absence of every kind of civilization, the former generally has an incomplete state of civilization, although in keeping with his unbridled passions. The barbarians all understand how to work the metals, and principally how to manufacture arms and utensils from them. They also appreciate the bright side of wealth and luxury, and barbarian chiefs have their treasures which they carry with them. History informs us of lengthy journeys in which the early Romans engaged, and we have seen what treasures their victorious generals brought back from countries that were called barbarian. These countries, it is true, generally stood in commercial relations with others farther advanced than theirs, such as Greece, Asia Minor, and afterwards the Orient, the latter of which was itself repeatedly called on to wrestle with the barbarians, and to protect itself against their inroads by paying tribute or making presents.

The treasures of the barbarians were thus composed in part of the fruit of their rapine, in part of objects of art which had more or less benevolently been offered to them by other names except the title of tribute, while still another part was the product of their own industry.

The most ancient remains of their goldsmithing is to be found in Russia, in the Museum of the Hermitage. Russia appears to have been the veritable cradle whence all these hordes issued, and it has for years collected with great assiduity all the antique objects manufactured by those barbarian nations. It has formed two distinct collections, that of the Antiquities of the Cimmerian Bosphorus, and the Scythian Collection, which already possess hundreds of trinkets and vases, or other objects of goldsmithing in solid gold dating from remote periods.

Among the latter we must particularly mention two pieces of a great intrinsic worth, and perhaps of a still greater artistic value; we append the description of a Roumanian archæologist, Mr. A. Odobesco:

One of them, figure 10, is a diadem or crown, a kind of a royal

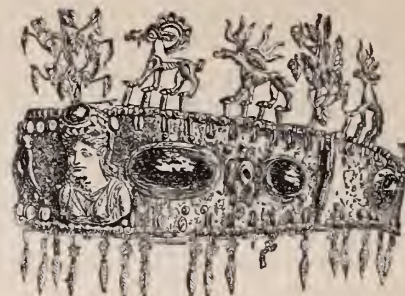

FIG. 10.

insignia of the greatest richness. It was found at Novo-Tcherkask, on the banks of the Don, and made of very pure gold, ornamented with pearls, and a superb cameo of Greek workmanship. It would have made the center piece of the diadem, although it has been disposed of simply as an auxiliary.

The other object, preserved at the Museum of the Hermitage, is also wrought of very pure gold incrustated with garnets. It is an enormous fibula in the shape of a sparrowhawk, which holds a bunch of leaves in one of its claws.

Immediately after the find of this treasure of the goldsmith's work another discovery of great importance was made by some farmers who were engaged in plowing their land in one of the Danubian Provinces, near the city of Petrossa, in Wallachia—in this mountainous country once completely overrun by the Goths, who themselves were afterward expelled again by the irresistible invasion of the Huns. How, when or by whom it was hidden will most probably remain a problem forever—perhaps on the eve of some great battle between the contending forces, and the owner doubtless fondly hoped that by to-morrow evening he would unearth it again. Fate had willed otherwise, however, and it was destined to be sepulchred for fourteen centuries.

The treasure, when found, consisted of twenty-two pieces, but unhappily the finders, impelled by sordid cupidity, smelted ten, wherefore only twelve remain, which have been exhibited in all the expositions of Europe, and are at present exhibited at Buda-Pesth, Hungary. Seven of the ornaments are set with garnets.

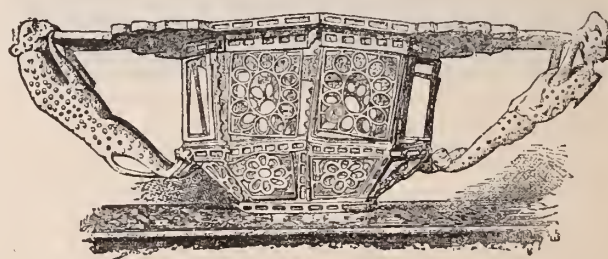

FIG. 11.

The first peculiarity that strikes our attention is that this treasure of Petrossa encloses neither arms nor pieces of armour, that none of the pieces partakes of Christian workmanship, and that at the same time very few of the pieces would serve for the uses of every-day life. On the contrary, all seemed to indicate that they may have served, a few of them, for instance, the fibulas, rings and collar-spangles, as ornament of a pontifical or princely costume; the others, jug, plate, patera and skillets, for drinking vessels or ceremonies of a belief anterior to the Christian. One of the rings bears a Runic inscription, and philologists have deciphered it as belonging to the worship of Odin, the principal god of the primitive population of Northern Europe. Now, it is known that the Goths, who took possession of the banks of the Danube in the first centuries of our era, had come precisely from these countries, and that they professed this religion up to the day of their conversion to the Christian faith,



which took place toward the end of the fourth century. We may, therefore, conclude that this Petrossa treasure is of Gothic origin, and that it belongs to the date just mentioned.

As is known, the Goths only remained two or three centuries upon the banks of the Danube. It would be comparatively easy to follow them in their new migrations, thanks to the finds of goldsmith's works of the same kind which have been made in several of the countries which they traversed. The Museum at Pesth has collected quite a goodly number of specimens. We find the art of goldsmithing, as practiced among them, plainest, however, in the countries where they settled permanently.

In the course of their migrations they sub-divided into several branches. Some invaded Italy, the others Southern France and Spain. The Franco-Hispanian branch, represented by the Visigoth monarchy, became of some importance and has left various pieces of goldsmith's work that speak of a high degree of civilization.

We are not confined to the simple recital of historians who speak of the vastness of the riches of that age or the value of the treasures gathered by the kings of the Visigoths. Many specimens have come down to us. The Cathedral of Oviedo, in Spain, possesses a very beautiful cross and several other objects of the work belonging to this age and nation, and in 1858 a very rich find of the crowns of Guarrazar was made which were sent to the Museum of Cluney.

This costly treasure is composed of eight magnificent votive golden crowns, ornamented with jewelry and crosses, all embellished with gems. To the lower part of the largest crown is suspended a series of golden letters incrustated with garnets, which letters, when joined together, compose the name of the Visigoth king Reccevinthus, who died in 672, and, very probably, there never was made a discovery of ancient gold articles that is so well authenticated as far as age is concerned.

Thus, by a curious chain of accidents, do we find the same style of goldsmith's work within the heart of Spain that we just now described as having been found on the banks of the Danube, and farther on we will find the traces in still other countries that were overrun by these conquering nomades, who are ordinarily styled "barbarians."

The principal part of the crown consists of a diadem or band with hinge and formed of two sheets of gold, one serving as lining to the other. Upon the outside sheet are set in three lines, thirty sapphires uncut, and as many more pearls of an enormous size, between which the goldsmith has cut out symmetric ornaments in form of palm leaves, the empty spaces having been filled in by lamellæ of garnets, the greater portion of which have fallen out. The upper and lower rim of the diadem are enriched with borders with regularly shaped ornaments, also cut out and studded with garnets and colored glass. Finally, to the lower border are hung by small chains a series of letters, all of which together form three words, "RECCEVINTHVS REX OFFERET." To each of these letters, very artistically wrought in gold with garnet incrustations, is again suspended a pale sapphire. The whole is pendant on a crystal button by four chains of very rich work. To the same button is also hung a very handsome cross of gold ornamented with pearls and sapphires, suspended in the center of the crown. It would be difficult to find a richer piece of work.



FIG. 12.

The other Visigothic crowns found at Guarrazar are far from being of the same importance. Three of them are rather remarkable for their shape. They are made somewhat in the style of cross-bar work, of solid gold, embellished with pearls and precious stones at each point of intersection, at the lower knobs are suspended drops.

In later excavations which the Spanish government caused to be made at the same place, other votive crowns were found, particularly that of the King Suinthila, all of which are kept at the *Armoria Real* of Madrid. With the exception of a few differences, these objects are all of the same pattern.



FIG. 13.

Let us continue to rapidly examine the principal remains of this Gothic goldsmithing, still existing in the other countries that were overrun by these hordes that came from the banks of the Danube or those of the Baltic.

At Ravenna, in Italy, where the second branch of the Goths, which for sake of distinction was called the Ostrogoth, founded its capital at the moment of its greatest power in the time of Theodoric, was found some ten years ago a broken piece of a golden armour, incrustated with garnet and *cloissonage* enamel work, the finest of the kind, perhaps, that ever was manufactured. It belonged most probably to a cuirass, and is at present preserved in the Museum of the city of Ravenna.

At the Cathedral of Monza, near Milan, are preserved other objects of the same nature emanating from the liberality of the Lombard king, Agilulphe, and his wife Theodelinde, other conquerors, both of German origin. We would especially mention a very precious Evangel, the magnificent gold covering of which, of goldsmith's work, is ornamented with cameos, pearls, precious stones, and surrounded by a border of garnets and colored glasses.

The ancient and celebrated abbey of St. Mauricius in Valois, established by the Burgundians, contains a priceless relic, the shrine of St. Mauricius, born 539, and executed Nov. 27, 602, ornamented

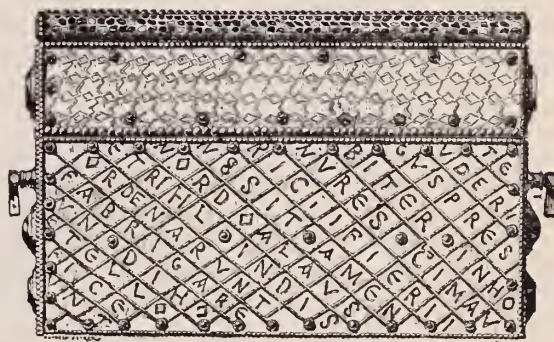

Shrine of St. Mauricius, Front Elevation, Figure 14.

with cameos, pearls and fine stones, in which we also meet again with the same style of jewelry work of garnet incrustation, and bearing both the name of the person who ordered it and of him who made it: Theodoric, Nordoalaus or Nordwald, etc.



Shrine of St. Mauricius, Side Elevation, Figure 15.

At Pouhans, in Champagne, France, in the vast plains where, in the fifth century, the Huns, conducted by Attila, and the Visigoths, under the command of Theodoric, met each other in battle array,

have repeatedly been found magnificent arms, enriched with goldsmith's work of *cloissonné* gold with garnet incrustations, and trinkets of the same work. These arms and trinkets, by the style of their ornamentation, entirely resemble the objects anteriorly found at Tournay in the tomb of Chilperic.

This discovery of the tomb of Chilperic, made in 1653, is the largest of the kind. The objects of which the treasure is composed, both by their intrinsic value and by the interesting epoch it recalls, is of an importance which immediately fixed the attention of the scientific world. They have since that epoch been carefully described, commented upon, and have ever since served as standards for establishing the date of a number of discoveries subsequently made. They are at present preserved at the Louvre, and consist principally of goldsmith's work; among them can be seen a sword hilt and scabbard ornament, a fibula, the buckle of a sword belt, a bracelet, the ornamental work of a purse and a large number of bees, all incrustated with garnets.

Other finds were also made in Britany, in a number of Anglo-Saxon graves, the specimens of which, gold trinkets incrustated with garnets, have been preserved in the art collections of Europe, both public and private; in England, London, Edinburg, Oxford, in the Mayer Gallery of Liverpool, etc.

We bring this chapter to a close with the statement that of the many finds throughout Europe, none antedates the period of the great people's migration.

(To be Continued.)

## Problems in the Detached Lever Escapement.

BY DETENT.

WE WILL now proceed to take up the so-called club tooth lever escapement. The great advantage of this style of lever escapement is its strength and ability to resist the "two" handed watchmaker; it also has an advantage in the form of the back of the tooth by which we can realize  $\frac{1}{2}$  a degree more impulse from the scape wheel, or even a full degree if the pallets are carefully made and set. A word of explanation. Some parties in noting my method of drawing the ratchet tooth lever escapement understood the description to say that the tooth only passed through 10 degrees of space for each escapement; this is a mistake, the tooth at every tick, or escape, passes through 12 degrees, 2 degrees being lost in drop, while 10 degrees of the advance of the scape wheel is directly applied as impulse to the pallet. But in the club tooth we can even in the commoner watches of this style realize  $10\frac{1}{2}$  degrees, while in a fine, carefully made escapement fully 11 degrees can be utilized. In the present illustration we use the pallets with equidistant locking faces. This arrangement is now generally adopted by the majority of makers of the club tooth lever escapement. There is a peculiarity about the escape wheel which should be particularly noticed, and this is, the escape wheel is larger than the nominal measurement. As, for instance, in the present instance we take (for our model) in our dividers  $2\frac{1}{2}$  inches and sweep on the sheet brass for our club tooth scape wheel a circle 5 inches in diameter (the cut is half size). But in reality the scape wheel is larger by the inclined face of the extremity of the tooth, which extends from the line circles *b* to *a*. This is because a portion of the impulse incline is on the tooth, instead of the impulse being derived entirely from the pallet as in the ratchet tooth escapement. In the present cut it is, of course, understood that only a portion of the scape wheel is shown. We sweep the circle *b b* 5 inches in diameter, as shown in fig. 1, and also sweep the segment shown in fig. 2, and divide it into degrees as has been described in a former communication. We next draw the line *c d*, and with our dividers take from the circle at fig. 2 30 degrees, and establish the lines *d e* and *d f*. We raise a perpendicular on these lines (see November, 1883, number of this

journal), and determine the location of the center of pallet action at *h*. We next sweep the circle *i i* from *h* as a center (it is, of course, understood that we use the  $2\frac{1}{2}$  inches used to sweep the circle *b b*, as the parent of all the measurements used in our delineations), and on this, from where the line *h g* crosses the circle *i i*, lay off  $2\frac{1}{2}$  degrees and draw the line *h j*; and next set your dividers on the center *d*, and through the intersection of the lines *h j* and *d f* sweep the circle *a a*; this line establishes the extreme points of the scape wheel teeth, and gives  $2\frac{1}{2}$  degrees of the 10 degrees of lever impulse action to the incline on the club teeth. In the present form the pallet action is divided so that  $2\frac{1}{2}$  degrees of the impulse is derived from the form of the tooth and 6 degrees from the pallet arm, with  $1\frac{1}{2}$  degrees lock. We next establish the width of the pallet arm. To do this we lay off 7 degrees (from the line *d f*) on the circle *b b*, and draw the line *d k*. We next set our dividers with one leg at *h*, and sweep the circles *l l* and *n n*, through where the lines *k d* and *f d* intersect the circle *b b*. Now it is evident that the inner and outer angles of the entrance pallet must be somewhere on these circles, no matter in what position the pallet stands. The

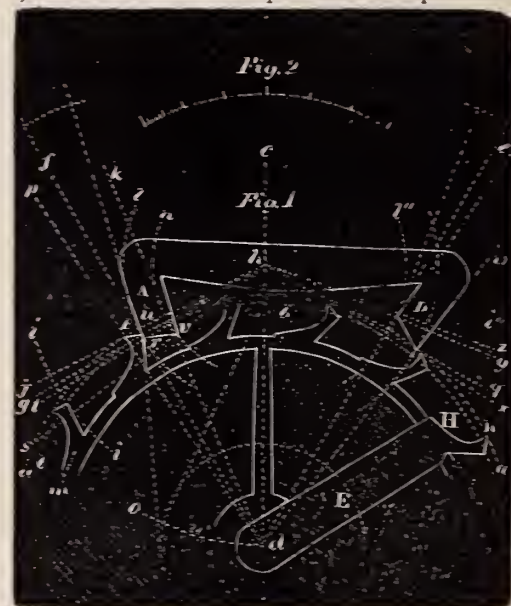

length of the tooth is established by taking one-half of the space from one tooth to another (12 degrees), and set it off on the line *c d* and sweep the circle *m*. The front of the club tooth has the same angle as the ratchet tooth (24 degrees) and is established in the same way, by sweeping the circle *o o*. To draw the incline plane of the tooth we lay off on the circle *b b*  $3\frac{1}{2}$  degrees and draw the line *d p*. Now draw the line at *r*, from the circles *a b* between the radial lines *f d* and *p d* as shown, and we define the impulse plane of the tooth at *B*. On the circle shown at *i i* we establish the extent of the pallet action. Now, it is evident that the angle at *v* of the pallet *A* (entrance pallet) when the tooth *B* escapes, will be swung around on the circle *n*, until the extremity of the tooth *B* will pass or escape from the pallet *A* on the circle *a*. To define the pallet action we lay off on the circle *i i*  $1\frac{1}{2}$  degrees for lock, and draw the line *h t*; this defines the lock. We next add 6 degrees more arc on the circle *i i*, and draw the line *h s*. Where this line (*h s*) crosses the circle *i i* is located the inner angle of the entrance pallet. By drawing a line from the intersection of the line *h t* with the circle *l l*, to the intersection of the line *h s* with the circle *n n*, we establish the face of the impulse plane of the entrance pallet *A*. The manner of laying off and delineating the locking face and general form of the pallets, except as described, is no way different from the method given for the ratchet tooth pallet. To delineate the exit pallet we continue the circle *l* until it again crosses the circle *b*, when it coincides with the line *d e*, from the intersection of *l* with *b*, we lay off on *b* 7 degrees to represent the width of the pallet and draw the line *d w*; we also draw from *h* through this intersection the line *h x*. We find the circle shown at *i*, continued at *i'*, on this we lay off from where *h x* intersects it  $2\frac{1}{2}$  degrees, to represent the impulse plane

of the tooth and draw the line  $h q''$ ; we next lay off 6 degrees on  $i''$  and draw  $h y$ ; we add  $1\frac{1}{2}$  degrees and draw the line  $h z$ . The 6 degrees just mentioned represents the impulse plane of the pallet, and the  $1\frac{1}{2}$  degrees the lock. It is evident as the pallets vibrate back and forth in their action that when the pallet  $D$  is engaged the line  $h z$  will occupy the position shown at  $h x$ . Consequently, to correctly delineate the locking face of the pallet  $D$ , we must raise a perpendicular to the line  $h z$ ; the manner of doing this has already been described. In making a model of such a scape wheel a piece of sheet brass large enough should be taken so the accessory lines can be carefully drawn. In laying out the teeth all that is necessary is to drill a hole in the sheet brass corresponding to  $d$  and carefully file out a piece shaped as shown at  $E$ , with the correct form of a tooth at one end as shown at  $H$ ; by putting a needle through a hole in the piece  $E$ , and a hole in the plate from which the wheel is to be cut,  $E$  can be used as a templet to mark around with a sharp point to get the exact form of each tooth. The manner of proceeding is to drill a hole at  $d$ , sweep the circles  $a m$ , sweeping  $a$  last, and while the dividers are still set for  $a$ , space it into 6 parts; divide these into 5 each; this will give 30 divisions; let the point of the movable tooth  $h$  be placed at every other space and mark out the teeth, when they can be sawn out. The arms and other parts are made as for the ratchet tooth wheel.

(Copyright, New York. All rights reserved.)

### Russian Reproductions

At the Metropolitan Museum of Art.

[BY JOHN W. MILES.]



A King's Bracelet, Figure 1.

NO PERIOD since the Renaissance has there existed a greater respect for the relics of past taste and skill than that which prevails to-day. The workmanship of hands that centuries ago mouldered into dust, the inspirations and sentiments that swayed the minds of artists long since at rest, and the implements, utensils and ornaments which were used by nations existing now only in history, bring to the modern world a vast amount of historical, moral and æsthetical instruction upon which we build our own superstructure of civilization, and out of which we weave our finest webs of artistic conceptions. From the noisome shades of crypt and tumulus the vase-recorded chronicles of antiquity spring again to life, touching those universal traits of nature which truly "makes the world akin," and teaching again and again the truth that whether in earthen sherd or creamy marble, in sun-baked clay or rusted bronze, in glass, or silver or gold, the soul of the artist cannot die, but forever lives to reveal its humanity to all succeeding generations of mankind. Every fragment, therefore, which bears upon it the impress of thought is of value, not alone to the antiquary but to all who delight in the self-interpreting language of art, and every effort to bring the people into closer connection with the treasures of antiquity accelerates the growth and power of native genius, yielding that subtle influence which, in both art and song, speaks from soul to soul without regard to time or season.

It is a matter, therefore, for more than usual congratulation that the Lords of the Committee of Council on Education in Great Britain succeeded four years ago, through Earl Granville, then Secretary of State for Foreign Affairs, in obtaining permission from the emperor, ecclesiastical authorities and numerous private owners, to re-produce in fac-simile those articles of plate which were known to be preserved in the Kremlin at Moscow, the Hermitage at St. Petersburg and other storehouses of art in Russia. The value of this achievement may be more fully appreciated if we remember the

national characteristic of exclusiveness which is so strongly developed in the Russian people. That inborn repugnance to any disclosure of their inner life, repelling investigations either with a calm taciturnity or with willful misrepresentations, has been in the past the plaint of very many ordinary travelers. Even the Marquis de Custine, who secured privileges of observation far exceeding anything before obtained, writes, as late as 1843, that "In Russia secrecy presides over everything; a silence that is superfluous insures the silence that is necessary; in short, the people are Chinese disguised; they do not like to avow their aversion to foreign observation, but if they dared to brave the reproach of barbarism as the true Chinese do, access to Petersburg would be as difficult for us as is the access to Peking." The collection which was secured by the Lords comprises three hundred and three pieces, all of which were reproduced by electrotypy and hence may be safely trusted as exact copies of the originals. Three sets of *replicas* only were made, one for the Museum at South Kensington, one has been taken for Cincinnati and the other enriches the exhibits of the Metropolitan Museum of Art in New York.

Being desirous of examining these objects, the writer during the early part of January, 1884, applied both to the director of the Museum, General L. P. Di Cesnola, and to the donor of the collection, Mr. Henry G. Marquand, receiving from these courteous gentlemen the kind permission of numerous private inspections with every facility at their command for an exhaustive study. In the pursuit of information regarding this collection the observation of the writer has been greatly assisted also, not only by the *carte blanche* so generously extended by the Museum authorities, but by the writings of other pens, notably that of the *Antiquites du Bosphore Cimmerien*, and *Comptes rendus de la Commission Archeologique de St. Petersburg*, from which has been gathered several illustrations without incurring the additional labor of original drawings. The writer would also state, lest the title of this essay should appear misleading, that a comparatively small portion (82) of the pieces are of pure Russian work, for although Russia has existed as a nation for over a thousand years, and although her vast domain occupies one-seventh of the territorial part of the earth's surface, she has given birth to very few artists in any of the higher branches. Semi-barbaric as a large proportion of her people are, nevertheless in her larger cities and towns there is a state of culture and refinement equal to anything in the west and which should produce its quota of assistance in art progress. Whether due to the form of government or to a national lethargy we must admit that so far Russia has given very little, proportionately, to the world of art. Quoting again from the Marquis de Custine: "Here the *artistes* obtain wealth but they do not draw inspiration; riches and elegance foster talents, but that which is yet more indispensable to them is the good taste and the freedom of public opinion. The Russians have not reached the point of civilization at which there is real enjoyment of the arts. At present their enthusiasm on these subjects is pure vanity; it is a pretense like their passion for classic architecture. Let these people look within themselves, let them listen to their primitive genius, and if they have received from Heaven a perception of the beauties of art they will give up copying in order to produce what God and nature expect from them." Certainly the advice of the Marquis has a clear ring to it, breathing a wise counsel that other nations than Russia need not hesitate to accept.

The fac-similes in the possession of the Museum include many objects executed by the artists of Italy, France, Germany, England and other countries, which were originally gifts to the Czar and other nobles, and types of the art work of the periods to which they belong and of the countries producing them. The most ancient among them all are those excavated from the antique tombs of Scythia, revealing not only the influence of the Grecian art but also workmanship purely Greek in design and execution. The sepulchres of the Scythians were among their most sacred possessions around which clustered those sentiments which nations less nomadic bestow upon home and fireside. When Darius, in his unsuccessful invasion

of their country, sent to inquire why they always fell back before his advance without giving battle, Indathyrus, their king, returned this reply: "This is the case with me, O Persian! I never yet fled from any man out of fear, neither before nor do I now so flee from thee; nor have I done anything different now from what I am wont to do even in time of peace; but why do I not forthwith fight thee I will now explain. We have no cities nor cultivated lands for which we are under any apprehension lest they should be taken or ravaged and therefore should hastily offer you battle. Yet, if it is by all means necessary to come to this at once, we have the sepulchres of our ancestors; come, find these, and attempt to disturb them, then you will know whether we will fight for our sepulchres or not; but before that unless we choose we will not engage with thee."\*

Out of the mouths of such grim store-houses the modern world gathers a large proportion of its facts regarding ancient history and ancient arts. The fictile-painted vases of the Greeks, the exquisitely cut gems and other rare exponents of an age brimming over with rich artistic conceptions, are treasures for which we are almost wholly indebted to early burial rites and the kind guardianship of mother earth.

Fac-similes of Greco-Scythian relics thus exhumed (of which we are somewhat familiar through books and illustrations) are now brought within reach, and will be soon placed on exhibition to the information of the people and the delight of admirers of art work in metal.

A reference to the initial letter of this chapter, figure 1, will give some idea of the rich artistic beauty of the ornaments worn by the Scythian kings. It represents one of two bracelets of gold exactly alike, each weighing  $41\frac{1}{2}$  zolotinks† and measuring 6 inches in diameter. Even amid all the other marvelously beautiful works of Grecian skill this merits especial admiration for exquisite taste and perfect execution. The massive rolling cable has its two ends terminating with Theban Spinxes,‡ a collar upon the neck and with the body fastened into a ferule of filigreed work having a border of blue enamel. A knot of gold thread similar to the band is held in the paws and joins the open ends. Other bracelets, with lions' heads or with mounted Scythians, are also in the collection, demonstrating the high excellence of the Grecian goldsmiths four and five centuries before our era.

Our next illustration, figure 2, is also a gold bracelet or armband, weighing  $25\frac{1}{2}$  zolotinks, and having a diameter of 7 inches and a width of about 1 inch. This was worn upon the right arm of the king below the elbow. It is formed of two plates of gold, one over the other, the outer or superior plate being worked in *repoussé*, representing two episodes in Greek mythology and dotted with the flower of the myosotis. The borders are narrow and filigreed.



A King's Bracelet,  
Figure 2.

The two subjects depicted upon this piece are among the most interesting of the heroic fables of Greece. Thetis in her struggles against Péleus, and E'os (Aurora) with Keph- alos, or, most probably, E'os carrying the body of her son Memnón who was killed under the walls of Troy. Of the first it will be remembered by the reader that Thetis, the most beautiful of all the Néréides, was loved and sought by both Zeus (Jupiter) and Poseidón (Neptune). Themis, however, having predicted that the son of Thetis would be a greater man than his sire the gods desisted, and desiring to reward the virtue of Péleus gave her to him in marriage. In order to escape from the misfortune of marrying a mortal, Thetis changed herself into all the forms, taking successively fire, water, a serpent and a lion, but Cheirón, becoming informed of the will of the gods, revealed to Péleus the means of winning her. The fruit of this union was the famous Achilleus (Achilles). Upon our bracelet Thetis is actively defending herself against the hero, who in turn is threatened by a lion—a symbol of the form taken by the goddess.

The second subject may have two significa-

tions, as I have stated, but it is most likely that it represents E'os and her son. Homer tells us that Memnón was of divine beauty. His father was Tithónos, son of Laomedón, king of Troy, and he himself fought upon that side during the siege, killing Antilochos. A combat with Achilleus over the body of Antilochos proved fatal to Memnón, when a truce was declared for restoring to his own people the body of the hero. Whether this is what the artist intended or whether he had in his mind the myth of E'os and Keph- alos, he had an opportunity for the most beautiful and delicate expression. In the latter he could depict the love of the lover in contrast with the love that subdues the woman; in the former the overwhelming love of the mother—both ideas being equally exquisite.

The design of the figures and draperies are in the grand style of the age of Phidias, and the piece was, without doubt, made at or near his epoch (5th century B. C.) Each scene is repeated five times around the outer circumference.

One of the most interesting pieces as regards association is a mask of gold weighing 62 zolotinks, from the tumulus in the neighborhood of Glinstche, a Tartar village which to-day adjoins the gates of Kertch, figure 3. This was found in 1837 by Mr. Aschik. In

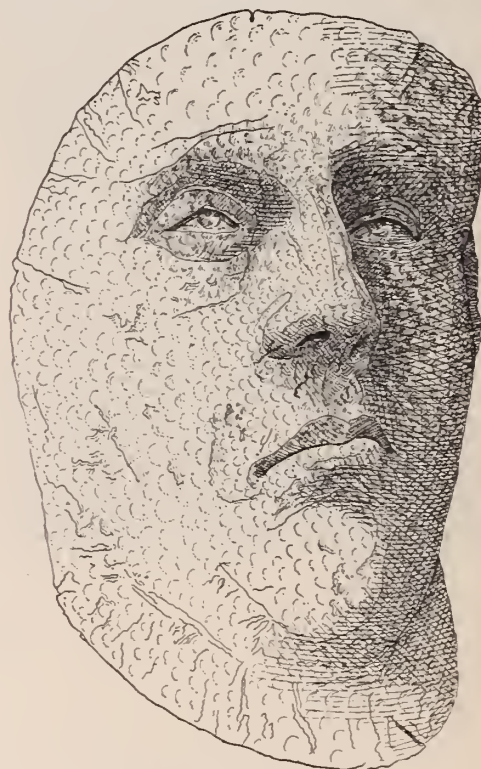

Gold Mask of a Queen, Figure 3.

excavating this tumulus Mr. Aschik discovered, at a depth of fourteen feet, a sarcophagus of marble having a cover in the semblance of a pediment and with acroteria at the sides like those often seen in ancient burials. The sarcophagus was buried in the earth of the tumulus itself. It contained the skeleton of a woman whose face was covered by a mask,§ and surmounted with a funeral crown. In his report of this discovery Mr. Aschik says: "My joy was mixed with surprise when upon removing the cover I found in the sarcophagus a skeleton with a golden face and a diadem upon the head and completely dressed. The robe of this queen was covered with golden ornaments; the stuff which covered the head and fell as far as the waist had retained its color. It was a woolen tissue with golden designs, but at the first contact with the air all the stuff fell

‡ The Theban (Thebes in Bœotia) Sphinx differed from the true Egyptian representation. The former had the head of a woman, body of a lion, and was winged; the latter the head of a man, body of a lion, and was without wings. Further, the Greeks gave the Sphinx any position, while with the Egyptians the figure was always carved lying down.

§ The ancients employed masks not only in the theatre but also in religious ceremonies, and in the festivals of certain divinities, such as Bacchus, Cybele, Isis, Syria, etc. The mask was first made from the bark of a tree, the wood covered with leather or woven stuff. In funerals they were used to cover or veil the face of the dead as a symbol of respect.

\* Herodotus, IV., 127.

† A zolotink is equal to about 4.266 grammes.

to dust and left only some golden spangles."|| We are already familiar with the fact of golden garments being made and worn by the ancients, but those which have been found are of wrought gold without any other material, and not woven into the texture of silk or other fabric as at the present day. The dress of this queen, therefore, could not have been like the one described by Pliny\* as worn by the younger Agrippina, wife of Claudius, but covered with small attached dots of gold forming little or no part of the stuff itself. Both the mask and the crown are judged to be of primitive workmanship, but the latter, not being included in this collection, I have no means of confirmation as to that. The mask certainly is crude in finish, which may have been due to the haste with which it was prepared, but it bears evidence of a bold, unhesitating hand and one thoroughly conversant with the work demanded. It was forged from the middle of a placque of gold and the marks of the hammer are quite distinct, although not quite so pronounced as might appear from the illustration. It is probable that the artist had a plaster cast of the face before him which was moulded immediately after death, and in the mask itself there are perceptible hollows in that portion of the eyes corresponding to the pupils, which a slight pressure easily indents at death. The artist probably finished his labor in one day in order that the face might be covered as soon as possible to hide the ravages of decay. The features of the mask would seem to indicate a woman of something over thirty years of age, and the name Rheseuporis, graven in dotted Greek letters upon a silver plate found in the tumulus, identifies her as the wife or favorite of a prince of that name—a name common to eight kings of the Bosphorus since Tiberias and before Constantine. This fixes the date at not later than about A. D. 212-229. The tumulus, which has been named that of the "Reine de la Masque" (Queen of the Mask) contained, also, two ear pendants with bezels of garnet very much damaged, a circle of gold matching two bracelets, three rings (one in massive gold), all in the positions, upon head, hands and arms of the skeleton, which they would naturally occupy in life. At the side of the skeleton there were found a plain pin of gold, a spindle, a bridle and a small satchel or purse, made of red leather and ornamented with the figure of a bird in black leather fastened on the outside. There were also two little fibulæ, one of gold and one of bronze, some beads of both glass and cornelian—probably forming originally a necklace—a golden flagon and several garnets mounted in bezels, a sort of medal, and lastly, about one hundred little stamped plates of gold, having been evidently strewn over the clothing of the queen. All these articles, found both within and without the sarcophagus, I have enumerated on the authority of *Antiquités du Bosphore Cimmerien* in order to give an idea of the rich store of antique objects which seem to fill all these excavated Scythian tombs. The lower part of the sarcophagus was hewn from a solid block, and to-day forms the basin of a fountain which exists in Tzarskaia-Pristane in Kertch.

In an Indian Lotah-shaped vase of electrum, figure 4, found in a tomb of the Koul-Oba, we have a representation of the features, dress and weapons of the Scythes in a scene evidently intended to perpetuate some warlike achievement of the king. The form of the vase is characterized by the graceful outline which was so strongly an attribute of the Greek workmanship, and in connection with the finished and harmonious details of the figures—some of which appear to be portraits from life—designates the piece as a product throughout of a Greek artist. The scene itself is situated in a plain covered

|| *Mon ravissement fut mêlé de surprise lorsque le couvercle enlevé je découvris dans le sarcophage un squelette à visage d'or un diadème sur la tête et complètement vêtu. Le vêtement de cette reine était tout parsemé d'ornements en or, l'étoffe dont était couverte la tête retombait jusqu'à la ceinture et avait conservé sa couleur. C'était un tissu de laine à dessins d'or mais au premier contact de l'air toute cette étoffe tomba en poussière et ne laissa que des paillettes d'or.*

\* *Nos vidimus Agrippinam Claudii principis edente eo navalis proelii spectaculum indutam paludamento auro textili sine alia materia.*—"We saw Agrippina, wife of the Emperor Claudius, at an exhibition of a naval battle dressed in a cloak of wrought gold without any other material."

with enameled flowers. The figures arranged in groups tell a continuous story. We have first the king sitting upon a hillock and leaning upon his lance listening intently to the relation which is being given by the person kneeling before him. It is evident that some great enterprise is about to be undertaken, and the narrator is reporting the position of the enemy, the plan of battle or other serious matters attending its execution. In the second group the king appears again, although, being wounded in the mouth, the likeness is less strikingly apparent owing to the expression of pain which distorts the features. In the third group his majesty has been wounded in the leg and himself directs the application of the bandages. The resemblance in these figures is remarkable, and, as Dubrux states that in the skeleton found there were two teeth missing and also



Vase from the Tomb of Koul-Oba, Figure 4.

evidence of some malady that swelled the lower jaw, the interpretation of the pictorially recorded story is quite probable. Dubrux also asserts in addition that the king's skeleton was that of a man of thirty or forty years of age, and measuring 6 feet 4 inches high. The figure bending the bow had also its significance (possibly a symbol of preparation for war), and the bow itself is of the Scythian form which, we are told, was crooked and something similar to the oldest Greek letter *sigma*. The true Grecian bow was almost entirely straight, being curved only at the tips. I know of but one instance where the Scythian bow is represented in the hands of a Grecian, which is a work wherein Appolo and Heracles are represented together, the latter carrying a bow of the Scythian form.

The vase was placed in the tomb of Koul-Oba near the feet of the queen—a precious souvenir of the king's exploits. Its form is not unfamiliar to modern art, and the decoration of the lower part especially is extensively used in designs of the present day. The ornamental band is evidently treated conventionally, but the costumes of the figures may, I think, be relied upon as exact portraits. Some portions of the armour we shall have occasion to refer to again later on.

We come now to another interesting piece from the same source, which is in silver and of a form similar to the *patera* or *cylix* of the Greeks, figure 5. There were two of these found absolutely alike



Cup from the Tomb of Koul-Oba, Figure 5.

and having the peculiarity of a loose disk fitting into the bottom of

the interior. In the shape of this cup—which is perfectly plain—we find that simple beauty which was always so strongly developed in the work of the Greek artists. It is thought to have been used as a drinking cup, and that when required the disk was placed in the interior, converting it into a vessel for pouring out libations to Appolo. The disk itself is a thin plate of silver engraved and gilded with a design representing Hélios, having rays surrounding his head and urging forward his four “dazzling white” steeds, *Eos*, *Æthón*, *Bronté* and *Astrapé*, with a whip which he holds in his right hand. The small portion of the earth which is given on the line of the horizon is sprayed with enameled flowers—an emblem of rejoicing at his appearance.

(To be continued.)

### Exhibition of the French Crown Diamonds.

FOR THE first time since the Paris Exposition of 1878 is an opportunity offered to the public to admire the French crown diamonds, and it is very probably also the last time; the idea of selling them and using the money for better purposes is daily considered more seriously under the republic.

In the large state *salon* of the Flora pavilion in the Louvre, has been built the handsome, but at the same time burglar and fire proof pavilion, which, propelled by a simple mechanism, sinks at night or at any threatening danger into the ground, together with all its precious contents. Treasures of modern goldsmithing, bronzes in the manufacture of which, as is well known, Paris stands unrivaled; watches, and other products of the finer art trades, fill the remaining space of the *salon*, because it was necessary to exhibit as much material as possible, the income being intended for the *écoles professionnelles du Syndicat*. It is barely worth mentioning that the crown diamonds are the center of attraction. Pillowed upon deep-red velvet cushions, every set has by itself been tastefully arranged upon one of the eight divisions of the pavilion—and indeed, the admirable stones show off to great advantage, with their unsurpassable iridescence, glowing in all the hues of the rainbow, and the eye does not tire in looking at them. An admirable spray of flowers, composed of thousands of diamonds of the collection, silently but impressively informs us that we are in the presence of baubles once worn by the queens and empresses of France;\* bedded above this field are arranged the largest diamonds, several of which bear a historical name. Surrounded by five brilliant stars in semi-circle reposes the gigantic “Regent” upon its pillow; farther below we see the “Mazarin;” to the right the oldest crown diamonds, which are characterized by their cutting; to the left a buckle of Cape diamonds with a yellowish tinge; tiaras, shoe buckles, rosettes and brooches are seen in large numbers; a four-string necklace composed wholly of brilliants; a pair of bracelets also of diamonds; simple hoops and diadems for the hair and brow; necklaces; large and small crowns studded with diamonds, adorn several other divisions, while rubies, sapphires and emeralds, interspersed between these matchless solitaires and master works of jewelry, heighten the effect of the latter.

Truly overpowering is the effect of a necklace composed of pear-shaped pearls and colored jewels, in the Oriental style of network.

\* The translator could do no less than quote the trite, but true, Biblical verse: “Better is a mess of herb in peace, than a stalled ox and hatred therewith,” when mustering the group of illustrious persons who wore these diamonds for the past one hundred and fifty years: Mazarin, who bought the largest, was hated and despised by the people; Louis XV. loaned them to his courtesans, Madame de Barry, etc.; Marie Antoinette was beheaded; Josephine divorced; Marie Louise returned in disgrace to Austria; Marie Amélie, wife of Louis Philippe, was driven from the country; Eugénie dethroned and driven from the country. Surely France has all reasons to alienate property with as black a history as its crown diamonds. Will the ill-luck that until now clung to them be transferred to the purchaser?

Much admired is also the marvellous pearl diadem with the alternating round and pear-shaped pearls; rosettes and buckles, single cords with pendant pearls and smooth, many-stringed necklaces belong to the ornament. Ten long strings of pearls nestle closely together, although each one represents a king's ransom. Pearls signify tears, and the last princely wearer of this *chef d'œuvre* of the art of the jeweler, the proud and beautiful Empress Eugénie, who wore the crown jewels so often to enhance her personal charms, was called on to verify the truth of this old saying.

Every ray of the sun falling upon this matchless collection of jewels, draws a flood of sparkling light from them, while the pearls glitter in their mat, mellow luster peculiar to them. The insignia of orders are grouped between two parade swords, and fill an entire division; large, flashing stars covered with brilliants, represent the main orders of Europe, together with the ribbon of the knighthood of the garter with its verse in brilliants, and the peculiar Asiatic order of the elephant. The body of the animal is enameled white, while colored jewels adorn the palankin upon its back.

And yet, what a contrast between the productions of the art of jewelry of a pampered age and the remarkably simple and sombre crowns of Charlemagne and Louis XV., which are kept in a glass case of the Apollo gallery of the Louvre, and still more so between the votive crowns of the Gothic kings, the treasure of Guarrazar in the Cheny Museum in Paris! It is a pity that these old treasures were not exhibited with the others, if for nothing else than contrast.

The public will also, upon the payment of a fee, be admitted two evenings per week, and the light of the 24 incandescent lamps of the pavilion will be flashed back with double their intensity from the thousands of facets of the crown jewels, and it is confidently expected that these evening exhibitions will be eminently successful.

When the student of French history dispassionately looks through its pages, it will be to him almost a matter of surprise that there should be any crown jewels at all in the *Garde-Meuble*, the vessel of the French state having been so terribly tossed about in tempests political during the last one hundred and ten years. The purchase of the Pitt diamond, only four years after the conclusion of the peace of Utrecht, when France was left bleeding at every pore, and with her finances to all appearance in a bankrupt condition owing to the war of succession, has often been quoted as a proof of her recuperative powers, and the comparative ease with which she can recover from seemingly overwhelming military and pecuniary reverses. On the other hand, the transaction might be cited as an illustration of the cynical indifference to the sufferings of an indigent people exhibited by the Regent d'Orleans in lavishing a huge sum of money, which would have given bread to thousands, on a trinket for the brow of a child still in the nursery. The transaction, notwithstanding, was quite in keeping with the traditions of splendidly overweening selfishness with which the idea of French royalty was then surrounded. What could be fitter than that the circlet of sovereignty with the Pitt diamond should adorn a royal little boy whose juvenile copy-books are yet preserved in the library of the hermitage at St. Petersburg—one of them being headed with the exemplary maxim: “Kings do as they please; their subjects obey them.” When the royal little boy was taking exercise with his nurse one afternoon, on the terrace at Versailles, a great noble of the court took the child in his arms, and, pointing to the great concourse of people in their holiday dress—it was a fete day—in the gardens, said: “Behold, my king! all those men, women and children, their money, their prosperity, their lives belong to you.”

Clearly, although France might be insolvent—and chronically insolvent she continued to be until the cataclysm of the revolution and the *assignat* system brought utter bankruptcy, from which she rose permanently refreshed by ruin—it was indispensable that the king, to whom more than thirty millions of people “belonged,” should have a crown worthy of his autocratic “supremacy.” It was the Sieur Rodé fils who made the last royal crown of the *ancien régime*. It weighed thirty-two ounces and contained two hundred

and seventy-three diamonds and sixty-four colored gems. The circlet of very thin beaten gold was adorned with brilliants, rubies, emeralds and sapphires; the branches or arches sprang from eight flowers de luce; the basis of the crest was a row of pearls between two rows of brilliants, surrounded by a double flower de luce, of which the pear-shaped summit was the "Beau Sancy," a rose diamond of two hundred and twenty grains. The inner cap or "calotte," of this gorgeous badge of sovereignty was of violet satin, embroidered with gold, and enriched with seventy-five diamonds. The crown royal, manufactured by the Sieur Rodé fils, exists at present only in the portfolio of the collector of old engravings. The portrait of this vanity of vanities was duly taken for the edification of posterity, but the bauble itself is clear gone—as completely vanished as the more renowned diamond necklace of notorious fame.

That famous, or rather infamous *Collier de la Reine* had its origin in a whim of Louis XV., who, in his infatuated dotage, wished to bestow on Madame de Barry the costliest set of diamonds that could be collected throughout Europe. Shameless as he was, he hesitated to present the "Regent" or the "Sancy" to his mistress, but otherwise the royal spendthrift gave *carte blanche* to the court jewelers, Böhmer and Bossange, who ransacked the diamond markets of the world to produce a necklace, which they valued at two millions of livres. How Louis XV. died from one of the most horrible forms of small pox; how Böhmer and Bossange, fallen into difficulties through their inordinate purchases of jewels, vainly strove to sell the necklace to the young Queen Marie Antoinette; and how they were ultimately swindled out of the precious necklace by the notorious Madame de la Motte and her associates, are matters of history. The diamond necklace disappeared piece-meal. Its counterfeit presentment is likewise extant in engravings, but the article itself is no more. It vanished. The Crown Royal of France was not long in following it; but, strangely enough, throughout all the vicissitudes of the revolution, and notwithstanding the terrible straits for money to which the successive Republican governments between 1791 and 1800 were reduced, the State never lost its hold on the "Pitt" and the "Sancy" diamonds. Indeed, in one sense the Republican rulers of France were conservators rather than destroyers. They melted down all the church bells to make "sous" of, and cast the lead of all the coffins in the royal tombhouse at St. Denis into bullets. They sowed potatoes and mangold-wurzel in the gardens of the Tuileries, and allowed the mob to demolish scores of castles and abbeys, but they did their best to preserve the furniture and ornaments of the royal palaces from annihilation, and between the cessation of the Reign of Terror and the termination of the rule of the Directory an immense collection of jewels, furniture, and objects of art were brought together. There were not enough gems, however, to furnish forth the diadem of a new monarch; and Napoleon I. was fain to entreat the well-known jeweler, M. Edmé-Champion, to give him credit for that Crown Imperial which, metaphorically, the Corsican "aventurier" confessed that he had "picked it out of the kennel." But the crown which had encircled the brow of a Bonaparte was deemed unworthy to press the forehead of a restored Bourbon. Louis XVIII., elected to be taken as crowned, and for the *sacre* of Charles X., a new crown was made. The jewels in it have long since been separated from the body of the diadem; and the "Regent" was displayed in an isolated state in the Paris Universal Exposition of 1878. Neither Louis Philippe nor Napoleon III. was ever crowned; and the contingency of any future head of the State in France requiring the services of a Sieur Rodé fils or of an Edmé-Champion, appears, to say the least, extremely problematical. Old crowns partake, to a considerable extent, of the nature of old clothes, and are not exempt from the same vicissitudes to which cast-off garments are liable. Still the "Regent" is worth more than a disused overcoat, and cannot so easily vanish into space.

## Palladium.

A VALUED correspondent to THE JEWELERS' CIRCULAR requested us some time ago to furnish him with full data concerning this metal; his request is complied with by the following, clipped from a European source:

This metal was discovered in 1803 by Dr. Wollaston ("Philosophical Transactions," 1804 and 1805). On adding bi-cyanuret of mercury dissolved in water to a neutral solution of the ore of platinum, either before or after the separation of that metal by muriate of ammonia, a yellowish-white flocculent precipitate is gradually deposited, which is cyanuret of palladium. When this compound is heated to redness, cyanogen is expelled and pure palladium remains. In order to obtain it in a malleable state, the metal should be heated with sulphur, and the resulting sulphuret purified by cupellation in an open crucible, with borax and a little niter. It is then roasted at a low red heat on a flat brick, and when reduced to a pasty consistence it is pressed into a square or oblong perfectly flat cake. It is again to be roasted very patiently, at a low red heat, until it becomes spongy on the surface, and when quite cold it is condensed by frequent tapplings with a light hammer. By alternate roastings and tapplings, the sulphur is burned off, and the metal sufficiently dense to be laminated. Thus prepared, it is rather brittle while hot, which Dr. Wollaston supposed to arise from a small remnant of sulphur ("Philosophical Transactions," p. 7).

Palladium resembles platinum in color and luster. It is ductile as well as malleable, and is considerably harder than platinum. Its specific gravity varies from 11.3 to 11.8 (Wollaston). For fusibility it is intermediate between gold and platinum, and is dissipated in sparks when intensely heated by the oxy-hydrogen blow-pipe. At a red heat in oxygen gas its surface acquires a fine blue color, owing to superficial oxidation, but the increase is so slight as not to be appreciated.

Palladium is oxidized and dissolved by nitric acid, and even the sulphuric and muriatic acids act upon it by the aid of heat, but its proper solvent is nitro-muriatic acid. Its oxide forms beautiful red-colored salts, from which metallic palladium is precipitated by proto-sulphate of iron, and all the metals described, excepting silver, gold and platinum.

It is only half as heavy as platinum, so that it is much better adapted for making very accurate balances and other philosophical apparatus, the graduated scales of astronomical instruments, etc. It destroys the color of gold, one part fused with six of gold forms a white alloy, which from its hardness and durability was, it is said, employed by Troughton for the graduated part of the mural circle for the Royal Observatory at Greenwich. It possesses little or no elasticity; it is a very bad conductor of heat and also less expansible. It may be alloyed with many metals—gold, silver, iron and steel. The alloy with iron is brittle, and in the proportion of one per cent. it is said to improve the quality of steel for certain cutting instruments.

A manufacturer has sent us a spring of, we believe, unalloyed palladium, and at once we are forced to say that we consider it an unfit material for the use of balance springs of chronometers; first, from its great weight, and, second, its behavior under the pliers. In attempting to curve it into figure, it is as dull and as inelastic as lead itself, and the curve falls down, nearly touching the second coil of the spring. Chronometer makers, as a rule, understand the nature of steel, and soon find out that some steel hardens at a much lower temperature than others, etc.; and on the other hand, if those springs advertised as palladium springs are alloyed, which they must be, they cannot be pure palladium springs, but an alloyed metal, containing palladium in more or less quantities. The alloy may be of nickel, or of steel, etc.; if it is alloyed with silver it becomes dental alloy. It will be the grand test to place them side by side with chronometers with steel springs on the public trials at the observatories, and if they give flattering results on their first trials it will take years to prove that they possess any superiority over the

steel springs, or are of a suitable material for the use of balance springs to chronometers.

The following results are obtained from an English firm, E. Dent & Co.: Mr. Dent says that palladium springs were first tried by his grandfather, E. J. Dent, who found that with a palladium spring of 11.34 inches long a chronometer with a glass balance took, for a change of temperature from 32° Fahr. to 100°, 2' 21" as against 6' 25" lost by a chronometer with the usual steel spring 11.04 inches long. Further, as regards the palladium spring, that of this amount —2' 21"—1' 48" is due to loss of elasticity, and 33" to increase of length, as against 5' 6" due to loss of elasticity in the use of the steel spring, and 1' 19" increase in length. It would appear in these experiments no allowance is made for the increase of the diameter of the balance; in the case of the experiments by Berthoud, with a brass balance and a steel spring in one of his marine watches in passing from 32° to 92° Fahr.:

|  | Sec.       |      |
|--|------------|------|
| Loss per diem by expansion of diameter of balance.....       | 62         |      |
| Ditto, by loss of spring's elastic force.....                | 312        |      |
| Ditto, by elongation of spring.....                          | 19         |      |
|  | Minutes, 6 | 23   |
|  | Min.       | Sec. |
| E. J. Dent's experiment with glass balance and steel spring, |            |      |
| loss per diem.....   | 5          | 6    |
| Loss of elasticity.....                                      |            |      |
| Ditto, increase of length.....                               | 1          | 19   |
|  | Minutes, 6 | 25   |
| With glass balance and palladium spring .....                | 1          | 48   |
| As due to loss of elasticity.....                            |            |      |
| Increase of length.....                                      |            | 33   |

Taken that the expansion of glass is equal in both instances in the disc of the balance used for these trials, it is difficult to ascertain the correctness of the trials. According to the tables of Lavoisier and Laplace the elongation of glass tube, when heated from 32° to 212°, was  $\frac{1}{248}$  of its length, while brass was  $\frac{1}{32}$  of its length. Knowing the elongation of any substance for a given number of degrees of the thermometer, its total increase in bulk may in general be calculated by trebling the number which expresses its increase in length; thus, if a tube of glass elongates  $\frac{1}{248}$  when heated from the freezing to the boiling point of water, its bulk increases  $\frac{3}{248}$  or  $\frac{1}{82.67}$  of its former bulk. But palladium springs were abandoned by Mr. Dent from some cause not stated; how the present alloyed palladium springs will succeed becomes a question for time to solve; but we fear that they will not sustain their elasticity for any length of time; in such a case, a constant losing on the rates of chronometers must ensue.

Another great objection is urged against them: their excessive trembling and quivering motion under the vibration of the balance; this would arise either from the non-elastic qualities of the metal, or from the want of ability to stand the torsion, so requisite a quality in the springs of chronometers.

#### A Bric-a-brac Hunter in Morocco.

A CORRESPONDENT of the *Mercury* of Leeds, England, has been bric-à-brac hunting in Morocco, and thus relates his experience:

The leather work for which Morocco has so long been famous will probably disappoint most persons who visit the country. The usual red and yellow Arab slippers are to be obtained here at a very cheap rate. The common ones cost two shillings a pair, which is about half the price charged in Tunis. For ladies' embroidered slippers any sum up to five dollars a pair may be paid. Perhaps the most useful form the leather works take is in the shape of covers for foot-stools, embroidered in gold and silver wire. These covers may be bought for eighteen pence each, and when they have been stuffed with wool or horse hair they make remarkably good and handsome footstools, which have the advantage of harmonizing well with the present fashions in furniture and house decoration. I have seen inferior specimens of these cushions offered for sale in England. I need hardly say at prices greatly in excess of that which I have named. It is impossible to resist the conclusion that a brisk trade in these leather covers might easily be organized between Morocco and England.

Another staple industry of the country is pottery. Before me, as I write, stands a collection of platters, vases, jugs, etc., brought from Tangier. The cost of the whole collection was probably less than thirty shillings, and yet it includes many remarkably fine specimens of the gorgeous Rabat ware, which forms so telling an ornament in a modern hall or in a room in which a little brilliant color is desirable, as well as several shapely pieces of the blue and white wares of Fez and Mekenes. There are, too, in this collection a number of the earthenware drums, or tomtoms, of which mention has been made in the course of my narrative, as well as some of the quaint lamps which are used in the interior of Morocco, and which surely furnish the very earliest and crudest form of the duplex flame.

Lastly, in connection with this question of bric-à-brac, something must be said about the painted woodwork from Tetuan, which is so popular in Moorish houses. It is quite possible that its brilliant colors and rich arabesque patterns may seem gaudy to the European eye. But, gaudy or not, the brackets and mirror frames which are sent out from Tetuan are often singularly beautiful, and deserve a place in any house where things which are rare and artistic are not cast aside merely because they happen to be unconventional.

I have said enough, I think, to satisfy the bric-à-brac hunter that he will find at least as much in Tangier to engage his attention as he will discover in the curio shops of Nice, or Naples, or Florence. He must, however, beware of the Oriental modes of doing business. There is only one thing of which he need not be afraid in Tangier, and that is of offering too small a sum for any article he wants to buy, when he begins his bargaining. One day a man who dealt in the matting of which I have spoken, and of whom I had purchased one or two pieces, came up to Bruzeaud's carrying a fresh piece on his shoulders. He spread it out upon the terrace for my inspection. "Very good!" said he. "Yes," said I; "but I don't want it; I have bought enough." "Very cheap!" he urged. "I don't want it," I answered. "Six shillings!" he cried; "worth ten shillings!" "Nonsense! I tell you I don't want it." "How much you give me?" he demanded next. "Sixpence," says I, in order to get rid of him. "Sixpence!" he laughed derisively. "No; five shillings." "Sixpence!" I repeated, doggedly. He laughed once more, rolled up the matting, hoisted it on his shoulder, and turned towards the steps leading from the terrace. Suddenly he paused, propped the roll of matting against a tree, and, coming up to me with outstretched hand, said quietly, "Very well, I take sixpence." He could not refuse money when it was offered to him, however trifling be the amount. I was so much ashamed of this transaction that I gave the fellow his sixpence and his roll of matting, which was twelve feet long by five wide.

#### Exposition of Goldsmithing at Nuremberg in 1885.

THE JEWELERS' CIRCULAR, sometime ago, spoke of the projected International Exposition of works of the precious metals and their alloys, to be held at Nuremberg, Bavaria, in 1885. The Presidency of the exposition was tendered to and accepted by the King Louis II., of Bavaria, and the various medals of merit are being struck at the royal mint.

Both the foreign and German Embassies and Consulates have enlisted in the promotion of the undertaking, and it is due to their exertions that quantities of East Indian work trinkets and ornaments of the Cabyls, specimens from the treasure of the Shah of Persia, etc., have been promised. The plan has met with the warmest approval in Spain and Portugal, and Japan has also given notification of its participation.

The historical department promises to be of a high interest, and many possessors of old and rare chef d'œuvres have promised to send theirs.

The buildings for the purpose are nearly finished and ready for apportionment, and everything that was suggested by experience to enhance the comfort of the exhibitors, and to place their goods in as favorable a light as possible, has been thought of and incorporated in the structure.

The government has signified its willingness that the goods will be admitted free of duty, and those not sold permitted to be withdrawn free of duty, and promises in all other respects to favor the best interests of the exhibitors to its utmost power.

We hope that America will be represented fully.



## How to Make and Engrave Silver Bangles.

BY EXPERT.

THE MANNER of breaking the electric circuit was sufficiently explained in our last, and now we will describe the arrangement of the magnets and such parts as are necessary to the production of the dots. As we recommended for such small work as a dime the changing of the pentagraph to  $\frac{1}{10}$  proportion, and as the bars of our pentagraph are 12 inches, one-tenth must be  $1\frac{1}{10}$  inches for the short bar; consequently our stippling arrangement can only rest on or be secured to one of the short bars and project backward over one of the main bars as shown at *a b*, fig. 1. There are many

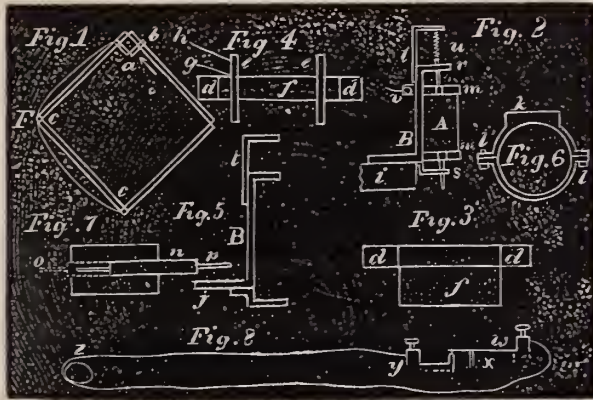

ways by which the stroke can be given, but it is of importance that the stroke be given as near instantaneous as possible in order to have the work look perfectly even. A good form for the arrangement of the stippling point is shown at fig. 2, which is an enlarged view seen in the direction of the arrow near *a*. It consists of a helix *A*, formed of insulated copper wire (No. 24). Insulated wire, as my readers are probably aware, is wire wound with some non-conducting substance like silk or cotton to prevent the coils of wire from coming in actual contact. Wire wound with silk is the best; it costs more but it is worth the difference. The helix should be about 2 inches long and be wound on a spindle  $\frac{3}{8}$  of an inch in diameter. There is some care necessary in making the helix and other working parts. To make the helix, take a piece of wire about 4 inches long and  $\frac{3}{8}$  in diameter, and wrap it with two turns of writing paper, glueing the turns down as you wrap it as shown in fig. 3, where *d* represents the spindle and *f* the paper. The spindle should not be wrapped so tight that it cannot be drawn easily out of the paper tube which the paper when dry forms. After the paper is dry two discs of thin wood should be slipped on the paper tube and glued fast as shown in fig. 4, where *f* represents the paper tube and *e e* the wooden discs. These discs are glued fast to the paper tube and form a spool on which the insulated wire is to be wound. In winding on the wire a small hole should be made in one of the discs, and the end of the wire should be allowed to protrude as shown at *g*, then go on with the winding as if you were winding thread on a spool, keeping the layers even until the spool is full. In the present case the first course or layer should be wound on so as to cover the paper tube (with the wire *d* inside it), evenly from disc to disc, when we should brush over the wire a coat of tolerably thick shellac varnish, made by dissolving shellac in alcohol. The coat of varnish should be allowed to dry perfectly, when you should try if the wire *d* can be removed. There is generally no trouble about getting the wire *d* out if care is taken when the paper *f* is put on. Go on winding a course of wire and varnishing with shellac until the spool is full. Heating the ends of *d* with the lamp will hasten the drying, but such heating is apt to make bubbles and lessen the stability of the helix. After the spool is full a hole near the outer edge of the disc should be made to permit the outer end of the wire to protrude as shown at *h*. We have now the helix made and the two ends of the insulated wire wove together so as to make connection. The ends of the wire when first wound should protrude about 3 inches. The wire *d* should now be withdrawn leaving

a hole through the center a trifle over a quarter of an inch in diameter. The ends of the paper tube should be cut away even to the discs, and the helix mounted as shown at *A* in fig. 2. The manner of mounting is to take a heavy piece of sheet brass—No. 8 or 10—about  $\frac{3}{4}$  of an inch wide and 4 inches long, and bend one inch of it at right angles, as shown at *B*, fig. 5, the part at *j* being secured to one of the short pins shown at *a*, fig. 1. The helix *A* is clamped to *B* by means of two open boxes as shown at fig. 6, when the part at *k* is flattened and screwed to the cock *B* with 2 screws. These boxes (fig. 6) are made in half and secured together with two screws shown at *l l*. These clamps or boxes are shown at *m m*, fig. 2, and serve to hold the helix *A* firmly in place. The principle on which the helix works is that if we take a helix, as shown in fig. 7, and connect the wires *g h* (which are the two ends of the wire forming the helix) to a battery, and insert a piece of iron wire as shown at *n*, we will find a strong tendency of the wire *n* to be drawn in until it assumes the position shown at the dotted lines *o*. Or, perhaps it will be better understood if I suppose a helix 2 inches long and a piece of iron wire as long as the helix, is inserted one inch in one end. Now the full magnetic tendency of the battery is exerted to draw the wire into the helix until the center of the wire corresponds to the center of the helix. In making one stippling machine we take advantage of this principle and insert in each end of *n* (the soft iron wire to be drawn in) two smaller wires to serve as guides to *n*, and let these wires pass through the guides *r s*, fig. 2, we have the elements of the stippler. A good deal of care must be used in fitting up the piece *n* and guide wires *o p*, to have them true so the iron wire *n* will vibrate back and forth in the helix without touching or causing unnecessary friction. Attached to the wire *p* is a very fine spiral spring, such as telegraphers use to draw back the armatures to the relay of their instruments. This spiral spring is shown at *u*, fig. 2, and serves to draw the iron wire *n* upward and retain it in position until the current of the battery is exerted, when the large iron wire *n* is drawn down into the helix so quickly and with such force as to indent the work in hand by the properly shaped point on *o*. The ends of the wires *g h* are attached to the usual clamp screws for attaching the connecting wires of the battery, one of which is shown at *v*, fig. 2. But such clamp screws are in too common use to need further notice. The reader will remember that I gave the method of breaking the battery current in the last communication. I will say a few words about conveying the current from the part of the apparatus by which the current is broken in following the pattern to where it does its work at the stippling device. By having a support for the wires extending from *b* to *c*, fig. 1, at *F*, all fear of having the wires in the way can be avoided. The flexibility of the wires will compensate for the joint at *F*, and if the support (at *F*) is of wood their is no need of the connecting wires being insulated. Of course it is understood that if uninsulated wires are used they must not touch one another. By varying the length of stroke and by the strength of the battery the dots can be given of any depth. At fig. 8 is given a *resuma* of the principle; *u* represents the breaking spring, *x* the tracing point, *y* the connection, *z* the stippler.

## Lathes and Lathe Work.

BY THE MODEL WATCHMAKER.

ABOUT THE next thing to do in constructing our lathe is to mount it on a suitable table or bench. And also provide ourselves with a foot wheel. This should be quite heavy, weighing at least 35 pounds. If a second-hand wheel can be obtained and used to advantage, all right; if not, a suitable wheel can generally be got of some of those persons who deal in agricultural implements. The wheel should be about 2 feet in diameter, and can be grooved in the outer rim for a round leather band or can be used for a flat belt. A flat faced pulley or wheel can be used by glueing on the iron first

paper and then a piece of leather belting as wide as the belt to be used. After it has dried on, trim off the edges so the leather will present a convex surface. The flat belt will not leave the leather, as all flat belts have a tendency to run to the largest part of a wheel or pulley. The wheel should now be mounted on our arbor with a suitable crank as shown in fig. 1, where  $A A$  represents the arbor and  $b$  the double crank. Such an arbor is simply a piece of  $1\frac{1}{4}$  inch square iron forged to the shape shown, with the part between the dotted lines rounded for the action of the pitman or connecting rod connecting it with the treadle. The crank shown at  $b$  should have a throw of 5 inches which is doubled by the treadle as will be subsequently shown. This arbor is squared off at the ends as shown at  $a a$ , and in the center of the end is drilled a hole  $\frac{1}{8}$  of an inch in diameter and  $\frac{3}{4}$  deep; these holes are to be countersunk and serve to receive the set screws  $e e$ . These set screws can be bought of any large hardware dealer, and are known to the trade as case-hardened set screws. The size wanted is  $\frac{5}{8}$  diameter, 3 inches long under the (square) head, and the kind known as No. 5, which number only indicates that the point is cone shaped. These set screws pass through the frame at  $d$ , and the cone points enter the holes in the ends of the arbor  $A$  and form very cheap and easy running bearings. Such an arbor with its crank any ordinary blacksmith can make as well as round up the part  $b$ . The arbor should be  $24\frac{1}{2}$  inches long. The bench on which the lathe sets should be 30 inches long by 24 wide, and made of hard wood 2 inches thick. The frame work at

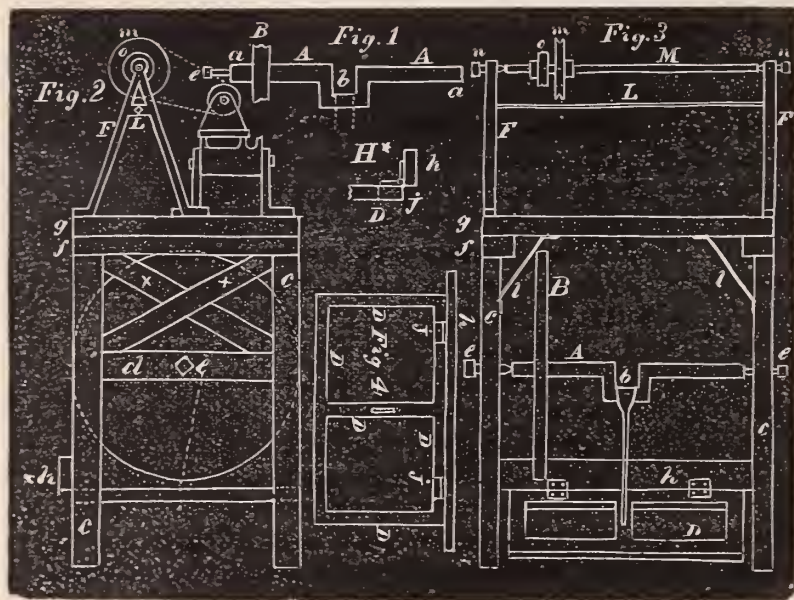

each end is indicated at fig. 2, where  $c c$  shows the upright supports made of hard wood joist 2x3 inches, as also the cross piece  $d$  which carries the set screw  $e$ . The cap piece  $f$  which joins  $c c$  is also 2x3 inches, but laid flatwise as shown in fig. 3. The bench should be 36 inches high to top off the 2 inch plank  $g$ . The treadle should be made of 5 pieces of hard wood (ash is preferable) tenoned together as shown at  $D D D D D$ , fig. 4; these pieces are  $1\frac{1}{2} \times 2$  inches, the 2 inch width extending horizontally. This gate treadle is hinged to a piece  $h$  extending from one frame to another as shown in fig. 3. The hinging is done with two heavy (4 inch) wrought iron butts as shown at  $j j$ , fig. 4. The piece  $h$  should be 8 inches above the floor, and the treadle  $D$  should not descend low enough to pinch one's toes. The manner of putting on the butts is shown in diagram  $H^*$ ; this enables us to have a free working joint. The bottom of the cross piece  $d$  should be  $10\frac{1}{2}$  inches above the floor, and at the center of this cross piece the set screw  $e$  should be placed for the arbor  $A$  to run on; thus the center of the arbor  $A$  will be 21 inches above the floor. These proportions are right for a wheel 2 feet in diameter. When I speak of the crank  $b$  having a throw of 5 inches, I mean the crank should be  $2\frac{1}{2}$  inches from the axis of the arbor to the axis of the wrist pin. This will cause the pitman or connecting rod to pass up and down 5 inches, and as this motion is doubled by the treadle gate it will cause the front of the treadle at  $k$  to move up and down 10 inches. The part of the arbor  $A$  where the wheel  $B$  goes can be rounded by forging or it could better be turned, but if carefully filed it will answer very well as the accuracy of the work produced

depends but little on this part. The balance wheel should be attached to the arbor  $A$  by a set screw or a key wedge. The pieces  $x x$  which serve as braces are 2 inches square. The braces  $l l$  are of iron and serve to strengthen the frame work. At fig. 2 is shown an end view of the lathe and table with countershaft supports. These end supports are of cast iron and are alike at each end, and are bolted to the plank  $g$  with small carriage bolts. Extending from  $F$  to  $F$ , fig. 3, is a rod  $L$  with a nut on each end which serves to keep  $F F$  from spreading by the action of the pointed set screws  $n n$  on which the countershaft  $M$  runs, the same as the driving axle  $A$ . The countershaft  $M$  is a piece of cold rolled shafting 1 inch in diameter and 24 inches long. On it are two pulleys, one 3 and the other 6 inches in diameter. These pulleys have hubs attached with set screws so the pulleys can be changed about. In fig. 3 the lathe is not shown as it would interfere with the view of the countershaft, but its position can readily be inferred from fig. 2 where an end view is given. In the cut the driving wheel  $B$  and pulley  $O$  are shown as for a flat belt, but on some accounts a round leather belt about  $\frac{3}{8}$  of an inch in diameter is to be preferred as it enables us to use the pulleys  $m o$  for different speeds. As, for instance, we let the band from the driving wheel  $B$  pass to the pulley  $m$  which is 6 inches in diameter. Now, of course, the countershaft  $M$  turns 4 times around for every time the wheel  $B$  turns once. If, on the other hand, we applied the band directly from  $B$  to  $o$ , which is three inches in diameter, we should have 8 times the speed of  $B$  by the countershaft  $M$ , and a band passed from  $m$  to the lathe an exalted speed would be obtained. The reader will see if one of the pulleys  $m$  or  $o$  was arranged for a flat belt such changes could not be effected. There is no doubt but a flat band has the most power, but a round band  $\frac{3}{8}$  inch diameter will convey all the power one can maintain for any length of time on the treadle. For turning any piece of steel or brass up to 1 inch in diameter, the 6 inch pulley  $m$  will give ample power; and for larger work a train of gear wheels extending from  $M$  to the lathe can be used. Such gear wheels can be made of cast zinc, as they are amply strong for such purposes, and if nicely made work very smoothly and with but little friction. We must now get up our slide rest, but first we must provide temporary centers for our heads to enable us to turn some which are true and reliable. The lathe can readily be made to cut the teeth in such zinc wheels as I mentioned. The wheels can be cast from a wood pattern molded in such sand as can be obtained from any foundry; full instructions will be given as the article progresses. It is to be noticed that fig. 4 is drawn to a smaller scale than the other figures, but all sizes are given in figures in the letter press.

### The Age of Inventions.

OUR NINETEENTH century, says the *Central Anzeiger*, is without a doubt the age of inventions, and the number of the latter is, perhaps, without an equal in the world's history. Of course, inventions for the benefit of the human race have been made ever since his creation, but when we look back simply for one hundred years, we must be astonished at the number of inventions made in so short a space of time, and how many of them date only since fifty years ago! The perfection of the locomotive and steamboat, telegraph, telephone, audiphone, electric light, sewing machine, photography, chromo-lithography, cylinder printing presses, elevators for high buildings, cotton gin, spinning machine, reaper and mower, steam threshing machine, steam fire engine, improvements in the manufacture of steel, dynamometry, the employment of anæsthetics to ease pain, and many more, pertain to this period. Various other important discoveries and inventions are in a nascent state. The use of coal gas and petroleum for heating and cooking is already a success, also the supplying of steam as motive power and for heating from central stations. The artificial preparation of butter is a notorious fact; flying through the air is a subject of experimenting, and the use of electric motive power is on the eve of being solved. Several problems of mechanics have until now evaded solution; but will they be more difficult to solve than the problem of the ocean cable, by means of which two persons separated by thousands of miles of ocean, converse with each other, or of photography, or of telephony? We employ chemical agents and freeze ice, which equals the best product of nature, in the torrid heat of midsummer. Our surgeons transplant the skin from the arm of one man into the face of another one; it adheres and becomes a part of his own body. We manufacture a mile of printing paper, swathe it around a spindle from which a printing press unrolls, prints, cuts, folds, counts, and in the course of time delivers, all counted, so many thousand of printed papers per hour.

Verily, our age is an age of inventions, and it would be foolhardy to draw the line between the possible and impossible.

## Foreign Gossip.

**PRESENTATION BOWL.**—A beautiful silver bowl, weighing about 7 pounds and richly chased, has been presented to Viscount Saver-nake on his coming of age. The bowl was manufactured by Elkington & Co.

**CORRECTION OF EARTH'S SURFACE.**—A proposal to construct a canal from the Atlantic, by the Gironde, past Toulouse, by Lang-guedoc, and joining the Mediterranean near Narbonne, is receiving a great deal of influential support.

**SOME CITY.**—A report was read at a late meeting of the Institute of Civil Engineers, in which the aggregate length of the streets of London was given at 1,966 miles, of which, excluding 248 miles in course of formation, 1,718 miles are thus maintained by various authorities.

**ENGLISH IMPORTATION OF WATCHES.**—During the month of June England imported 46,123 watches valued at £51,512, a large increase in number and value over the corresponding month of last year. For the first six months of this year there were 343,500 watches valued at £208,635, imported by England, of which number the United States sent 174,134 as against 157,641 sent the first six months of last year.

**PROTECTION AGAINST RUST.**—Dr. Beckers has invented a preservative against rust which is sold under the name of oil of caoutchouc, and which is said to have been introduced into general use by the German army. It is a varnish prepared by mechanical means which have hitherto been kept secret, but which result in so intimate a mixture of the oil and caoutchouc that the latter preserves all its elasticity and communicates it also to the oil. When rubbed by a flannel upon a metallic surface it dries slowly, forming a perfectly elastic, adhesive pellicle, which protects the metal from atmospheric influences.

**A STANDARD MICROMETER.**—A "standard" micrometer has been made for the American Society of Microscopists, by the U. S. Bureau of Weights and Measures. The scale is engraved on platinum-iridium, twenty per cent. iridium. The examination as to the correctness of this standard was carried on through seven months of last year by Prof. W. A. Rogers, of Harvard College Observatory, and it has now been accepted by the society. It is to be kept in approved safe deposit vaults, and not to pass out of the hands of the custodian except with the permission of the committee, president and secretary of the society, but other micrometers will be compared with the standard and the result certified to for a reasonable fee.

**WHERE DIAMONDS ARE FOUND.**—Until the South African mines were discovered the diamond was always found in sands and gravels, different from the mineral in which it was believed to be formed. At Griqualand West, however, the consolidated eruptive mud of the mines was believed by some to be the true matrix of the diamond; but opinions differed on the question, and arguments were found on both sides. M. Chaper, a French geologist, has, however, during a scientific mission to Hindostan, succeeded in finding the diamond in its mother rock. At Naizam, near Bellary, in the Madras Presidency, M. Chaper has found the diamond in a rose pegmatite, where it is associated with corundum. The tract of country is almost denuded of trees, bare and rocky, and the rains wasting the rock every year expose fresh diamonds in the soil. The rock is traversed by veins of feldspar and epidotiferous quartz. Here the diamond is always found associated with epidotiferous rose pegmatite. The diamond crystals observed are octahedral, but less distinct in line than the stones of South Africa, which seem to have been formed in a freer matrix. It follows from M. Chaper's discovery that diamonds may exist in all rocks arising from the destruction or erosion of pegmatite, for example, in quartzites with or without mica, clay, pudding stones, etc.

**TIME'S CHANGE.**—One of our home papers states that fifty years ago the English were so much astonished at the low price at which clocks were imported into the British Isles, that they seized a cargo of the clocks and sold them at auction, turning the proceeds over to the owner of the clocks. The profit on this transaction was so large that another cargo of clocks were sent to England forthwith. Again the prices fixed were low, and they were regarded as a deliberate undervaluation. The cargo was seized and sold as before much to the satisfaction of the owner of the clocks who made a great deal of money by it. A third cargo was soon sent with the expectation that it would be seized and sold in the same manner, but the English custom-house people had learned wisdom, and they allowed the Yankee clocks to pass in unmolested at the valuation fixed on them.

**CURIOSITY.**—A wealthy inhabitant of Vienna, Austria, had two "clocks of vitality" made, one for himself and the other for his wife. Beside the hours and minutes these clocks are provided with a certain kind of almanac which records the exact age of the parties. To these two clocks were added, in the course of time, four others for children born to them, which are provided in a like manner. The most remarkable feature of these mechanisms, however, is that while at the time of marriage the calendar hands indicated the husband's age to be 21, the wife's 17, the former is at present 51 years, 60 days and 8 hours, while the wife is 35 years, 9 days and 15 hours. Mathematicians and men "quick at figures," have for some time puzzled their brains how this difference could have arisen. Can it be possible that she sets back the hands occasionally? Avaunt, base suspicion.

**EIGHT DAY ALARM CLOCK.**—The specification of an English application for a patent for an alarm clock recites that the object is to provide alarm attachments for clocks, which will sound once each day for eight days with one winding up of the spring, and it consists in an eight day clock alarm constructed with a dial and cam connected with the clock work, and operating a lever connected by wires with an arm attached to the pallet of the alarm, and with a stop lever arranged to engage with stop pins attached to the pallet wheel, and provided with a follower to engage with a trip wheel connected with the main wheel driven by a spring. The cam revolves once in twelve hours, and the lever drops so as to release the pallet and allow the alarm to be sounded, while at the next revolution the alarm is prevented from sounding by the stop lever entering between the pins attached to the pallet wheel.

**THE THERMOMETER.**—Mr. R. H. Scott, President of the Royal Meteorological Society, London, has compiled some interesting notes on the history of the thermometer. The name of the actual inventor of the instrument is unknown, and the earliest mention of it as a scientific appliance then 50 years old was in a work by Dr. R. Fludd published in 1638. Bacon, who died in 1636, also takes notice of it. But the earliest thermometers were really sympiezometers, as the end of the tube was opened and plunged into water, which rose or fell in the tube as the air in the bulb was expanded or contracted. Pascal soon discovered that pressure as well as temperature affected such instruments. Simultaneously with them, however, thermometers with closed tubes were made in Florence, early specimens of which may be seen in the collection of the Florentine Academy. As to the instrument as it now exists Robert Hooke suggested the use of the freezing point; Halley, the boiling point and the substitution of mercury for spirit, and Newton, blood heat. Fahrenheit, although a German by birth, was a protégé of James I., and died in England. Réaumur's thermometer in its final form owes its origin to De Luc; and although the centigrade thermometer is almost universally attributed to Celsius, it was really invented by Linnæus. Celsius' instrument had its scale the reverse way, the boiling point being 0° and the freezing point 100°. Mr. Scott's paper concludes with a short account of the principal forms of the self-registering and self-recording thermometers.

## Workshop Notes.

**TO PART LEAD FROM GOLD.**—As lead melts at 617° F. and gold at 2,000° F., melting the lead and removing the gold would be the simple method for you to adopt for separating the two metals.

**TO BEND GLASS TUBES.**—Fill the tubes with finely-sifted sand, close both ends, and heat it over the flame of a Bunsen burner. It may thus be easily bent, without losing its roundness at the elbow.

**TO REMOVE GOLD.**—Gold is taken from the surface of silver by spreading over it a paste made of pulverized sal ammoniac with aquafortis, and heating it till the matter smokes and is nearly dry, when the gold may be separated by rubbing it with a scratch-brush.

**CLEANING GILT SURFACES.**—Gilt metallic surfaces are best cleaned with a solution of 30 grams (19 dwts. 7 grains) borax and 1 kilogram (32 ounces 3 dwts.) water; rub them gently with it, rinse with cold water, and dry with a soft linen cloth. Picture frames only bear pure water.

**TO CLEAN BRASS.**—The method prescribed for cleaning brass, and in use in all the U. S. arsenals, is claimed to be the best in the world. The plan is to make a mixture of one part common nitric acid and one-half part sulphuric acid in a stone jar, having also ready a pail of fresh water and a box of sawdust. The articles to be treated are dipped into the acid, then thrown into the water, and finally rubbed with sawdust. This immediately changes them into a brilliant color. If the brass has become greasy, it is first dipped in a strong solution of potash and soda in warm water; this cuts the grease, so that the acid has full power to act.

**SOFT-SOLDERING ARTICLES.**—Moisten the parts to be united with soldering fluid, then, having joined them together, lay a small piece of solder upon the joint, and hold over the lamp, or direct the blaze upon it with your blow-pipe, until fusion is apparent. Withdraw them from the blaze immediately, as too much heat will render the solder brittle and unsatisfactory. When the parts to be joined can be made to spring or press against each other, it is best to place a thin piece of solder between them before exposing to the lamp. When two smooth surfaces are to be soldered one upon the other, you may make an excellent job by moistening them with the fluid, and then having placed a sheet of tin-foil between them, holding them pressed together over your lamp till the foil melts. If the surfaces fit nicely, a joint may be made in this manner so close as almost to be imperceptible. The bright-looking lead, which comes as a lining of tea boxes, is better than tin-foil.

**ACID-COLORING SOLID GOLD.**—Saltpeter, 2 parts; salt, 1 part; muriatic acid, 1 part. Put saltpeter and salt into the coloring pot, and heat it without water, then add hot water sufficient to produce a thick paste, let it boil, add the muriatic acid and stir it up well. As soon as the brown vapor arises, plunge in the work quickly, being careful to submerge it completely (since the vapor will affect the work if exposed to it). Let the work boil over a quick and lively fire (and preserve it during the whole process) for about three minutes, stirring it about constantly, taking care not to let any part of it come to the surface of the liquid. Then rinse the work in a light pickle, and thereupon plunge it into hot water. Quick and careful handling in dipping in and taking out the work is important. This done, the acid color should be thinned by adding hot water, or one-half old color, which is preferable. Submerge the work again, let it boil two minutes, and should some pieces require it, such should boil one minute longer. Now boil the work in a pickle, two thimblefuls of muriatic acid to one gallon of water, then again in a pickle containing only a few drops of acid, then dry off the work carefully in hot sawdust. Remember that work not properly dried will draw spots.

**CLEANSING MAT GOLD.**—Take 80 grams chloride of lime, 80 gr. of bi-carbonate of soda, and 20 gr. table salt; pour over this about 3 liters distilled water, and fill in bottles, to be kept well corked. For use, lay the dirty articles into a dish, pour over the well shaken fluid, let it submerge them, leave them in it for a short time, and in extra cases when very dirty warm them a little. Next wash the articles, rinse them in alcohol, dry them in sawdust, and they will appear like new. The fluid is of no further use.

**TO PERFORATE GLASS.**—To perforate glass by electricity, Fayes (*Chemiker Zeitung*) makes a sheet of hard India rubber, 18 centimeters long and 12 cm. broad, for a battery of 12 cm. spark, runs a brass wire through it, and fastens it with a screw. The wire end he moistens by a few drops of olive oil, places the glass plate upon it, and passes the current conduit of the outer pole over the glass. The spark is then permitted to pass through the glass. By drawing the glass plate slowly over the caoutchouc, many small, closely situated together, are obtained, and the glass may be broken in their direction.

**COLORING GOLD AS IN ETRUSCAN JEWELRY.**—There are various methods for coloring gold as in Etruscan jewelry; in fact, every jeweler has a method of his own. The following, however, has been successfully used for some years, and has given general satisfaction: 2½ ounces crocus, 2 ounces yellow ochre, 1½ ounces verdigris, 1½ ounces copperas, ½ ounce white vitriol, ¼ ounce borax. All these ingredients are to be reduced in a mortar to an impalpable powder and intimately mixed with 5 ounces yellow beeswax; or, 20 dwts. saltpeter, 20 dwts. common salt, 2½ dwts. copperas, 2½ dwts. white vitriol, 2½ dwts. alum. The ingredients are to be put into an old crucible, and set over the fire, and the articles to be colored boiled in it until on trial they are found to have acquired the desired color. The beautiful satin finish is given to the class of goods called Roman gold by carefully brushing the dead gold surface with a scratch-brush made from spun glass.

**ACID COLORING.**—There are two processes for coloring similar in purpose and effect; the oldest is called dry coloring, because the chemicals used are solids, namely saltpeter, alum and salt; but acid coloring has come into more general use on account of its being easier to manage and of the wider range of qualities of gold which can be submitted to the process. The purpose is simply to remove from the surface of the gold all alloy, so as to leave a coating of pure gold of rich yellow color, which is very finely frosted, to obtain which, with perfect equality, it is necessary to have the surface smooth, then anneal and boil out in pickle, made of nitric acid and water; lastly, annealing black, before dipping in the color. A good formula for coloring mixture: Saltpeter, 9 ounces 12 dwts.; salt, 4 ounces 16 dwts.; muriatic acid, 6½ ounces. The effect on the article is necessarily to reduce the weight, therefore the quicker it is done the better, and, if the gold be properly alloyed, 1½ minutes is sufficient time to expose them to the action of the mixture, which must boil up till it fills a No. 10 black lead crucible. In all acid colored work there is between the body of gold and the outside color a brown coat of partially colored material, and if the work is left too long in the mixture the coat is much thickened, and the fine color may be easily peeled off, especially if the gold be too low in quality. The finest color and best surface may be obtained on about 15-karat gold, but the range is from 12 to 20 karats, and to be successful the operator needs considerable practice. Before using a crucible it is necessary to have it well annealed, as accidents are thereby avoided. To prevent a change in the color of goods after coloring, it is well to wash them in ammonia, which will neutralize any salts that remains in the somewhat porous surface, and if the articles are scratch-brushed, which slightly brightens them, they are less liable to soil. It is best not to give the ammonia bath till after brushing, following with a good wash in hot water and drying in hot sawdust.

## Trade Gossip.

L. F. Cahn, of this city, has opened a branch office at 67 and 69 Washington street, Chicago.

I. N. Miller, of the firm of Miller Bros., has just returned from a trip to Europe very much improved in health.

Louis Neresheimer, of the firm of E. August Neresheimer & Co., sailed for Europe in the steamer *Fulda*, Sept. 10.

C. N. Thorpe, of The Keystone Watch Case Co., left for Europe during the past month. His stay abroad will be a limited one.

Mr. G. Willemin sailed for Europe in the *Canada* Sept. 24. He has been closely confined to business for several years and goes abroad for his health.

Giles, Bro. & Co., Chicago, have perfected machinery for de-magnetizing watches and tools, which, it is claimed, works to perfection—doing its work well and quickly.

Comparatively few failures occurred in the jewelry trade during the summer months, an indication that the merchants have put their business in such condition that even dull times do not bring disaster.

Moses Kahn, of the firm of L. & M. Kahn, returned from an extended trip through Europe with a well selected stock of diamonds, watches and other desirable goods purchased by him while abroad for the fall trade.

The firm of Mussina Bros., Williamsport, Pa., has been dissolved, Sylvester Mussina continuing at the old stand. Wood Mussina has formed a co-partnership with I. E. Bowers, under the firm name of I. E. Bowers & Co.

Keller & Untermeyer are circulating in the trade an elegant lithographic advertisement illustrative of their specialty, which is highly ornamented watch cases. The picture is suitably framed, and, being printed in several colors, makes a most attractive advertisement.

Buyers who have been abroad this season are now returning with liberal supplies of European novelties. They were not in the least frightened by the cholera nor intimidated by the war in Egypt, neither did the French complications in China disturb their equanimity.

A plaque has been patented by Stella A. Jackson, of New York city. It is of glass, with a transparent spot in the center on which to mount a picture, the remainder of the plaque being frosted or made in imitation of porcelain by grinding, or by grinding and painting.

The trade is warned against an alleged watchmaker who goes by the name of Harry Hirsch. He has been operating in the interior of this State, claiming to have worked in Switzerland and England. He has an impediment in his speech, and has victimized a number of dealers by various petty tricks.

The collar button lately patented by Messrs. Krementz & Co., is claimed to have unusual strength in consequence of its being made from a single piece of gold without solder. The illustration given in their advertisement conveys an excellent idea of this new device, which promises to become popular.

Frank Aenzen, a clerk for Black, Starr & Frost, jewelers, at Fifth avenue and Twenty-eighth street, was held for examination recently in the Jefferson Market Police Court. When arrested pawn-tickets representing twenty gold watches were found on him. He had obtained over \$1,000 on the watches.

Louis Seyforth, an alleged watchmaker, recently went from this city to Utica, where he entered the employment of P. Taylor. He worked a short time and finally decamped with several hundred dollars worth of diamonds and watches belonging to Mr. Taylor. He was subsequently arrested in Canada.

Mr. Martin Marcus, of J. Emrich, returned from an extended trip abroad, Sept. 15th. While in Europe Mr. M. perfected arrangements to manufacture their own garnet jewelry in Prague. He brought out many novelties for the holiday season, among which are tiger claws mounted which are now so popular in Europe.

C. C. Offerman, for many years traveling salesman for L. A. Kotzow & Co., and for the past two years with Martin Copeland & Co., has severed his connection with the latter house and made an engagement with William Smith & Co., whose chains he will exhibit on the road hereafter. He is well known in the trade and makes friends wherever he goes.

A. & J. Plaut, of Cincinnati, carry a complete line of American movements and cases, and are prepared to fill orders on short notice. They also have in stock all the latest novelties and attractive goods in the jewelry line. This firm makes a specialty of emblems for fraternal and trade organizations, and make to order anything that may be desired of this nature, or in the way of prizes and trophies.

F. Krober is introducing some novelties in clocks for the holidays. There are many elegant designs in plush velvet, and ornamental cases of every description in a great variety of forms, including ink stands, toilette sets, etc., suitable for Christmas presents. The demand for ornamental goods, combining utility with artistic designs, is growing every year, and enterprising manufacturers spare no effort to keep pace with it.

At the New Jersey State Fair a few weeks ago, the crowd was thoroughly "worked" by industrious pickpockets, and, as a consequence, the loss of a large number of watches and chains, diamond pins and other articles of personal adornment was reported. There seems to be an organized gang of pickpockets that go about from one fair to another seeking victims. Local papers should warn the public to look out for them.

The importation of diamonds for the American market has been quite large this season, the buyers for American houses have scoured Europe in search of desirable goods in this line. Some of the settings this year are very attractive, combining artistic designs with fine, delicate workmanship that produce most desirable effects. Buyers this fall have splendid assortments of diamond goods from which to make their selections.

J. T. Scott & Co., agents in this country for the Roskopf Watch and Triumph-Roskopf, keep also a full line of American movements and cases, as well as a complete stock of desirable goods of all kinds. They keep up with the times in all novelties produced by the manufacturers. Their facilities for transacting business were greatly improved by their change of quarters this spring, and all orders are filled with the utmost promptness.

O. Johanson has devised a novel charm made from coin of the realm or any other realm. He splits the coin and then pivots them together with an invisible pivot; a portion of the metal inside is removed, making a receptacle for a portrait. Just now these are being utilized for campaign purposes, the candidates of either party being carried in miniature inside a ten cent piece or a quarter of a dollar. When closed the charm looks like an ordinary coin.

Lincoln, Bacon & Co. have just obtained a patent for an adjustable slide clasp for their roller chain gold bracelets. The trouble with the slide fastenings generally used for such bracelets is that they wear the edges of the chain. By the new device the chain is clasped tightly in an adjustable clasp, by means of which the bracelet can be lengthened or shortened to fit any arm. The clasp is variously ornamented and makes a handsome and desirable finish for the bracelet. It is entirely new, and has already given evidence that it will become popular.

The Chicago papers announce the failure of Henry G. Moorhead a jeweler doing business at No. 211 Madison street, for about \$1,720. He made an assignment for the benefit of his creditors to Joseph D. Hubbard, and soon after confessions of judgment were entered against him in the Superior Court in favor of Charlotte M. Moorhead for \$1,126; Alice Brown, \$429; and John Moorhead, \$165. According to the schedule filed by Moorhead his liabilities amount to \$6,070, while his assets, consisting of stock and book accounts, are valued at \$5,600.

Peripatetic peddlers of campaign medals, presenting the pictures of the various Presidential candidates, are to be met with on every corner, in the street cars and on the ferryboats. They are made by the million, sold at a low price, and the wonder is what becomes of them all. The various news companies have been handling them extensively this year, sending them in quantities to every newsdealer in the land. It is seldom anyone is seen wearing them in the street, so it is presumed that they appear principally in processions and "wigwam" meetings.

On October 1, Mr. Gustave Walter retired from the firm of Albert Berger & Co., with which he has been prominently identified for twenty years. "Gus," as he is familiarly called, entered the house of Albert Berger & Co. in 1864 as a clerk, was promoted to manager of the business and finally was admitted to partnership, continuing as business manager. His retirement is in consequence of new business arrangements he has in contemplation, of which the trade will be duly advised through these columns. He will take with him the best wishes of the trade in whatever line of business he may engage.

The show windows of the jewelers have, for the past few weeks, been a great source of attraction to passers-by. They are filled with new and attractive goods of every variety, rich in material and workmanship. Retail dealers report an increasing demand for gold goods for ladies' wear, these articles of personal adornment being once more in fashion. Novel designs in pins, ear rings, bracelets, etc., are to be met with on every hand, and it is not surprising that the ladies are captivated by them.

Mr. George F. Kunz, with Tiffany & Co., whose contributions upon various precious stones have appeared in THE CIRCULAR, is preparing a monograph on the American pearl. He proposes to give its history, describe where it is found and its peculiarities, whether due to locality or other causes; also to give estimates as to the production and value of those secured. Any person in possession of information on the subject will confer a favor on Mr. Kunz by forwarding it to him as early as possible.

An Atlanta paper contains a lengthy description of the jewelry establishment of J. P. Stevens & Co., of that city. It occupies four floors, the first and second as salesrooms, the third as jewelry factory and the fourth as watch factory. Every modern appliance is employed for facilitating operations in their business, and the most perfect system used in each department. The paper speaks in highly complimentary terms of the enterprise of the firm that has succeeded in building up so important an industry in the south.

Among the interested visitors to the Electrical Exhibition at Philadelphia, we noted the names of a number of gentlemen who have achieved distinction in the science of horology. Their studies have, naturally, led them to experimenting more or less with electric forces, and more than one of them has attained rank among the prominent electricians of the day. Our old friend and well known contributor "Excelsior" is one of these. He has already obtained several patents for electrical inventions of utility, and is pushing experiments with others with unflagging application. Professor Leonard Waldo, of the Yale Observatory, who is also a familiar contributor to the columns of THE CIRCULAR, is also well up in electrical science, and was chosen on some of the Committees of Awards at the Exhibition. Electricity will, in the future, play a more important part in horology and kindred sciences than it has heretofore.

The fifty-third exhibition of the American Institute opened Sept. 24, and will continue open until Nov. 29, and possibly longer. These exhibitions are doing magnificent work for manufacturers and merchants, affording them an opportunity to bring their goods before the eyes of thousands of interested persons. The manufacturers and merchants of New York are becoming alive to the fact that the energies of rival cities are attracting wholesale and retail trade to them. Chicago, Cincinnati, St. Louis, Louisville, Boston, Philadelphia and New Orleans have each done more by their respective exhibitions to secure enlarged trade than has been attempted by New York citizens. The managers of the American Institute Fair have during half a century offered to New York citizens the opportunity of taking the lead in all things pertaining to the methods and merits of annual expositions. They have encouraged American inventors, stimulated improvements in American manufactures, and afforded instruction to hundreds of thousands whose eyes and brains have been educated by the fifty-two expositions of human progress which have been held under their auspices. These exhibitions should be more generally utilized by the trade in this city.

The firm of Wm. Kendrick's Sons, Louisville, were recently swindled out of a pair of diamond ear rings valued at \$1,500, by the same means recently employed to defraud dealers in St. Paul and other western cities. A young man entered the store and introduced himself as Wm. Larr, Jr., a member of a distilling firm in good standing at Lexington. He looked at clocks, diamonds, etc., and left, saying he would order when he reached home. A day or two later a letter was received by the jewelers, written on a beautiful lithographed letterhead of the distilling firm, enclosing its check in payment of a clock. Soon after the young man appeared, inquired if his letter had been received, and again took a look at the diamonds. He finally decided to take the ear rings, provided the firm would accept a draft on his house in Lexington. This was agreed to, the jewelers having ascertained that the distilling firm was in good financial standing, and the diamonds were delivered. It soon got noised about that the young man had been buying furniture and other goods in the same way, and a telegram to Lexington brought the information that there was no such person as Wm. Larr, Jr. Meantime the imposter had left and no trace of him has been discovered. Moral—transactions with strangers should be on a cash basis.

J. T. Bonestell, of the firm of Levison Bros., of San Francisco, was in the city during the past month, on his annual pilgrimage to the city of ideas and business enterprise. The genial manners of Mr. Bonestell are well known to the trade, and he is as popular as he well can be. Of course, he was eagerly sought for by those having new styles of goods, for he is known to be a liberal but discriminating buyer. After business hours, and when every store and office was closed, Mr. Bonestell recreated at Coney Island, Long Branch and other watering places where youth and beauty congregate. He was entirely at home in such society, and after an evening at the seaside felt sufficiently recuperated to continue his business next day. He lost no time while here, either in his business transactions or in the enjoyment of the social side of New York life. Mr. Herman Levison, who has just returned from Europe after three years' absence, joined Mr. Bonestell in this city, and they returned together to San Francisco. Mr. L. was much improved in health by his trip abroad.

The following we clip from a Chicago paper, which shows that Chicago lawyers at least are very wide awake: The Chicago creditors of the collapsed jewelry firm of S. Friedman & Co., who failed recently, are said to be secure in their claims against the firm at all events, owing to the clever ruse of Jacob Newman, one of the attorneys. Friedman had a large clothing house at Minneapolis, and early Saturday morning Mr. Newman started for St. Paul, while his partner, Mr. Moses, entered the confessions of judgment here and prepared for a levy. At 10 o'clock Monday morning, Mr. Newman had engaged 60 men and 20 American Express wagons in St. Paul, and with them proceeded to Friedman's store, of which he had the key. In about an hour he had loaded up all of the \$40,000 worth of stock, and transferred it to a special train of three freight cars and a caboose of the Rock Island road, chartered at a cost of \$1,500. The engineer was directed to run to Chicago at the rate of 45 miles an hour, stopping at no county seats. At 6.30 this morning the train arrived at Blue Island, just inside the county line, when Mr. Newman found Deputy Sheriff Burke waiting to levy on the goods. It was a sharp trick.

The Tenth Annual Meeting of the New York Jewelers' Association was held at their rooms, 692 Broadway, on Tuesday, Sept. 9. The following officers were elected: Wm. R. Alling, President; Geo. C. White, Jr., Vice-President; A. K. Sloan, Treasurer. The Executive Committee re-appointed H. Olmstead, Secretary, a position he has occupied since April, 1878. The Executive Committee consists of the following named gentlemen: F. S. Douglas, Alfred H. Smith, E. Holbrook, C. H. Brahe, D. F. Appleton. The Finance Committee is: C. G. Lewis, J. A. Riley, L. L. Woolley, D. C. Dodd, Jr., B. K. Knapp. Membership Committee: F. H. Richardson, J. C. Aikin, W. S. Hedges, J. D. Lyon, J. G. Bacon. The Committee appointed to prepare a letter of condolence to be presented to the widow of the late D. H. Hopkinson, reported having sent the following:

NEW YORK, September, 3d, 1884.

*Dear Madam:*—By request of the members of the New York Jewelers' Association, at their annual meeting held September 2d, 1884, we beg leave to express to you their heartfelt sorrow and sympathy in this, the hour of your supreme affliction.

Mr. Hopkinson, although not a member of our association, was well known and highly esteemed by us all.

It was the privilege of some of our members to be on close personal and social intimacy with your late husband. To them his death will leave behind it a more poignant sorrow, but all of us will mourn his loss, and remember those gentle ways and kindly manners that made him so many friends.

In the prime of life, in the vigor of his early manhood, with, as it would seem, a long life of happiness and usefulness before him, with his life work well laid out yet hardly commenced, "God's finger touched him and he slept."

We are taught to believe and we do know, that sorrow like yours sooner or later must come to all, and is ordered for the best by Him who guideth all things, and "not even a sparrow falleth to the ground without His knowledge," so may our Heavenly Father be your constant companion and friend, direct you in all your ways, shed light upon your pathway in life, and as you bear the cross so shall you wear the crown, and gain "the golden key that opens the palace of eternity."

With our kind personal regards, we remain, dear madam,

Truly your friends,

THOMAS G. BROWN,  
A. K. SLOAN.



THE  
JEWELERS' CIRCULAR AND HOROLOGICAL REVIEW

*The recognized organ of the Trade, and the official representative of the  
Jewelers' League.*

A Monthly Journal devoted to the interests of Watchmakers, Jewelers, Silversmiths, Electro-plate Manufacturers, and those engaged in the kindred branches of art industry.

SUBSCRIPTION:

To All Parts of the United States and Canada,

**\$2.00 Per Annum; Postage paid.**

To Great Britain, France, Switzerland, Germany, the West Indies, Mexico, the Republics of South America, and Australia, \$3.00 per annum. Postage paid.

All communications should be addressed to SETH W. HALE, President, THE JEWELERS' CIRCULAR PUBLISHING CO., 42 Nassau Street, New York.

Advertising rates made known on application.

The Business Outlook Improving.

AS THIS number of THE CIRCULAR meets the eye of the reader the presidential campaign will be virtually closed. Election day is at hand, and the winner of the prize for which the two great political parties of the country have been contending for months will be awarded to one or other of the contestants. It will be a great relief to every one when the result is definitely announced, for this has been one of the most disreputable presidential contests ever known. From its earliest stages it has been characterized by disgraceful scandals and personal abuse of candidates and their adherents to an extent seldom equaled. The result of such a contest is to excite violent partisanship, and to gradually draw into the political maelstrom all classes of citizens, to unsettle business of all kinds and to produce a feeling of unrest and uncertainty. While this is always the case in a presidential election year, it has been especially so on this occasion because of the bitterness evoked by the personal nature of the contest, to which was added the disheartening effects of the Wall street failures early in the season.

But during all the excitement of the political campaign, and the dullness that pervaded all branches of business, there has been the utmost confidence that the fall trade would be all the better for the summer's stagnation; that when the election should be over business would resume activity, and business men would be all the more

energetic and all the more determined to take advantage of the favorable conditions that pervade the country. In our issue for October we alluded to the anomaly presented by the situation at that time, the crops having yielded abundant harvests, but business being dull because prices were so low that producers would not sell their crops, while money was abundant and buyers anxious to purchase. We predicted that this deadlock would soon be broken and that the crops would begin to move, stimulating business enterprise in all directions. Our prediction bids fair to be realized even sooner than we expected, for early in October there was a marked advance in the price of some of our agricultural products, corn, for instance, going up several cents a bushel in the Chicago market; wheat also had an upward tendency, as did most other staples. The effect was to bring out the harvests, and to put money into circulation. All kinds of trade felt the improvement, and toward the latter part of the month transactions in the principal trade centers became quite lively. The jewelry trade caught its fair share of the new impetus thus given to business, buyers were more numerous and a better feeling generally prevailed. There were many representatives of the trade in New York from all sections of the country, and their unanimously expressed opinion was that when the election was fairly over there would be a marked improvement in trade, and that the volume of business transacted between now and the holidays would compare favorably with that of any one of the previous five years. We observe, too, that this opinion regarding improvement in business after election is shared in by those journals especially devoted to the commercial interests of the country, and these give statistics showing the abundance of the harvest and the favorable conditions for trade that exist in the country. They attribute the dullness of the summer trade to the election excitement, but show that in previous presidential years the business of the summer and early fall was light, but was fully compensated for by the increased activity after election. This they think will be the case this year.

To sum up—the situation is decidedly more promising than it was a month ago; the political campaign is near its close; the deadlock that existed between the producers of our agricultural wealth and those who handle it have been partly, if not entirely broken by an advance in prices that has induced farmers to sell a portion of their crops, and grain is now coming forward liberally; money that has been lying idle in the banks is finding its way into circulation, and everybody is feeling better and richer in consequence. In reply to the salutation with which we greet everybody, "how's trade," we now receive the reply almost universally, "picking up," instead of the doleful announcement that it is "dead" that has greeted us for a few months past. We note, too, an increase in the number of express wagons that visit Maiden Lane and vicinity daily, collecting packages from the trade for shipment to fill orders from the country, which is the best evidence we can have that the retail dealers are reaping the benefit of the increased circulation of money, and are giving the jobbers an opportunity to share their good fortune. The indications now are that November and December will be excellent

months for the trade, and that the transactions between now and Christmas will tend greatly to bring up the average of the year's business to that of previous years.

### Diversity of Interests in the Trade.

THE JEWELRY trade may properly be divided into three distinct classes—manufacturers, jobbers and retail dealers. According to tradition, the lines of demarkation between these classes were formerly broad and distinct, each confining itself within the limitations fixed by custom, and not seeking to invade the province of the others. But customs change, and the complaint is now general that the barriers that once sufficed to keep these classes of trade apart are now being broken down and trodden under foot. The legitimate function of the manufacturer is to produce such goods as the market requires; of the jobber, to receive these goods in bulk and distribute them among the thousands of retail dealers; and of the latter, to sell them directly to the consumer. Each class is necessary to the other, and its operations do not necessarily conflict with its fellows. Manufacturers cannot readily reach all of the thousands of retail dealers located in all sections of the country; if they could, they could not afford to go into all the details necessary to conducting a limited amount of business with each. The intervention of the jobbers is, therefore, a necessity. These are located in the various commercial cities, and come in direct contact with the retail trade that is tributary to such cities. Catering to a limited extent of country, each jobber can supply the retail trade within his district with comparatively little trouble, and each constitutes in effect a branch house for the manufacturer. The retail dealer is in closer communion with the jobber located in his vicinity than he can hope to be with the distant manufacturer; his trade is sought by the jobber, and from him he can order goods when he wants them with a certainty of receiving them promptly and in such quantities as he may require. The jobber being near at hand, he relieves the retail dealer of the necessity of carrying a large stock of goods, which might go out of style before he could sell them, and affords him an opportunity to keep himself supplied with the freshest goods and the latest novelties. He is thus in position to suit the wants of his customers with alacrity, and, what is greatly to the purpose, without the employment of a large amount of capital. When these natural limitations are observed, trade runs smoothly; the manufacturer is not burdened with a multiplicity of customers and a confusion of accounts, but confines his dealings to the jobbers, who become his distributing agents, placing his goods in the hands of the great army of retailers, who are the only ones who should come in direct contact with the consumers.

But, as we have said, complaints are heard on every side that the traditionary laws of trade are being violated by each one of the three classes; the retailers complain that the jobbers seek to trade directly with the consumer; the jobbers complain that the manufacturers sell to retail dealers, and both allege that manufacturers also cultivate too intimate relations with the customers who should be the patrons of the retail dealers; the manufacturers complain—well, their complaint is a general one, and relates to the unbusinesslike habits of the trade in general and the jobbers in particular. Efforts have been made by the different interests mentioned to rectify the abuses of which they complain; the retailers have undertaken to proscribe the jobbers who sell to consumers, and the jobbers have threatened to have no dealings with the manufacturers who supply retail dealers without their intervention. Still another complaint charges jobbers and manufacturers alike with selling goods to merchants who are not in the trade, thus inducing them to enter into competition with the retailers for the patronage of the consumers.

That these complaints are founded in fact, every one familiar with existing business conditions can testify. When an evil exists it is

best to acknowledge it, seek for its cause, and try to discover a remedy. The primary cause of the troubles referred to, as well as many others, is undue competition. The business, in all its branches, is overdone; like "gold diggings" that have yielded profitably, it swarms with "prospectors," who delve in every crevice, wash down every embankment, crowd and jostle each other upon every stream, till the yield of profit is so diffused among the many who claim a share of it that none are satisfied, while many are driven to desperate means to maintain themselves. As the consumption of goods produced by manufacturers is limited, and the number of producers too great, the competition among them to dispose of their goods leads to the adoption of unbusinesslike methods to accomplish the object. They overstock the jobber if possible, and then some of them seek the retailers who should be the patrons of the jobber. The jobber, in turn, stocks up the retailer, and then undermines him in his own locality by stealing his retail trade away from him. Competition, too, induces the manufacturer and jobber to sell to the outside merchants, and thus competition begets competition, to the injury of all interested. This excessive competition can only be cured by restricting the credit system, which, in the jewelry trade, has long since passed the bounds of prudence. It requires so little capital to obtain a large credit in the trade that every Tom, Dick and Harry is inclined to set up as a jeweler, regardless of his business qualifications. He has everything to gain and nothing to lose, for if he fails his creditors will compromise for a few cents on the dollar and give him credit for more goods with which to make a fresh start. He thus comes into the market with a stock of goods that has cost him little or nothing, and is able to undersell his competitors, who are expected to pay dollar for dollar. If credits in the trade were subjected to reasonable restrictions there would be far less ruinous competition.

As to restoring trade to the traditionary channels, it is doubtful if that can ever be done. Like the Mississippi river in a heavy freshet, under the stimulus of excessive competition trade has broken down the barriers, and will continue to flow through the courses it has made for itself. In this it is governed by the immutable laws of supply and demand. These provide that every man shall do the best he legitimately and honorably can for himself, and if he can make more money by ignoring the customs of his particular industry, he is going to laugh at custom and go for the dollars every time. The motto of most business men is "quick sales and small profits," and with most of them the quick sales is a matter of necessity, owing to their limited capital. To make money they must turn their capital over as often as possible, buying and selling as rapidly as opportunity can be made. To do this the manufacturer is tempted to reach out beyond the jobber, and the jobber to compete with the retailer, while the prudent public is always going to buy where it can buy cheapest. If the manufacturer can realize cash for his products sooner by selling to a drygoods merchant than he can by selling to the jewelry trade, he will sell to him regardless of the protests of the trade. He would, no doubt, prefer to keep within the trade, but if outsiders treat him better than the trade does his preferences will give way to his desire for ready cash. So it is with the jobber—wherever he can realize a dollar the quickest there he is going for it, whether it be in the store of a gents' furnishing goods merchant, the study of a clergyman or the office of a lawyer. And these individuals will buy of him in preference to patronizing the retail dealer if they can save anything by doing so, precisely as the jeweler will buy his boots of a drygoods merchant in preference to the boot and shoe dealer if he can get them at a less price. Sentiment and tradition have nothing to do with business; dollars and cents have the innings and will make the score every time.

It is useless to kick against the pricks or to quarrel with accomplished facts. The trade itself is responsible for the evils that afflict it. It has encouraged a credit system that has long been a burden and a reproach to it; it has fostered illegitimate competition till competition has turned to rend it; it has pitted class against class



and individuals against each other; in the effort to counteract these evils it has sacrificed something of its old-time honor by debasing quality to save cost; it has substituted in its practices the illegitimate for the legitimate. No one class is more responsible for this than another; the retailer, by demanding extended credit and unusual privileges, has exhausted the patience of the jobber; the jobber, by similar methods, has antagonized the manufacturer, and the latter, by ignoring custom, has offended both the other classes. The evils complained of may be lightened, but their entire eradication, if ever accomplished, will be a work of time. As a beginning of the work of reform, the entire credit system should be revised, so that a person engaged in the business shall furnish at least a portion of the capital he works on and not rely entirely upon the creditor class for it. This would reduce competition decidedly and be a very great encouragement to that large and honorable class of merchants whose ambition it is to pay dollar for dollar. The retailers should aim to become better merchants, to supply each his market with such goods as sell readily, to diversify his stock accordingly, to buy on short time and meet his obligations promptly. When he treats the jobber as well as outsiders do, the jobber will be able to deal in a more businesslike manner with the manufacturer, and all will be less inclined to cut each others' throats. Each class has its rights as well as its grievances, and while the latter are so freely ventilated the former should be respected.

In this connection we desire to say that it is and always has been the purpose of THE CIRCULAR to represent every branch of the jewelry trade. It has no particular interests to serve, but seeks the good of the trade in general. To this end our columns are always open to correspondents to discuss any phase of the business, within reasonable editorial restrictions, and we cordially invite communications as well on the mercantile as the technical features of the business. Manufacturers, jobbers, retail merchants and all others interested are invited to a free expression of opinion in our columns.

---

### Free Trade and Protection.

THIS IS A question that interests every laboring man in this country, whether he follows the plow or works at the bench making watches or repairing jewelry. It is simply the question whether the laws of this country shall be made to protect him in the fruits of his industry, or whether he shall be placed in direct competition with the pauper labor of Europe. As this is now one of the great political questions of the day, and as Congress will be asked this winter to modify the tariff on imported goods, every man should be prepared to discuss the subject intelligently, and to use his influence to secure proper and reasonable protection to American industry. Mr. Robert P. Potter recently delivered an interesting lecture in Boston entitled "Protection and Free Trade To-day," which has since been published in pamphlet form by James R. Osgood & Co. of that city. We extract from it as follows:

"The abandonment of protection will in no way help the farmer, as the free-traders claim. It will stop immigration, and hence lessen the ever-increasing demand for food at home, while it will leave him in a much worse position than he now is in, in the matter of Indian and Russian competition. In the words of Judge Kelley, of Pennsylvania:

"The primary want of the American farmer is a quick, remunerative home market. When our mills, forges, furnaces and factories were busy and our operatives were well paid, we consumed nine-tenths of all the cereals we could grow; but with idleness prevailing in industrial centers, with the reduction of wages and the power to consume, and with great branches of industry expelled from the country, we cannot look to an increase in the home demand or the maintenance of past prices."

"How does this question affect the men and women engaged in

manufacturing, mechanical and mining industries and transportation in the United States? The time has come for this army of 4,400,000 persons to examine free trade and protection for themselves. Our imported manufactured goods come chiefly from Great Britain, France, Germany, Austria, Italy, Spain, Portugal, Belgium, Holland and Scandinavia. In these countries over 31,000,000 men and women are engaged in manufacturing and mining pursuits. The average annual income of these millions is less than \$4 a week, or \$200 a year. Unless they emigrate to the United States, they have no hope to rise from the condition to which they were born.

"The official returns of these countries bring out the astonishing fact that over 8,000,000 persons, a number exceeding one-fourth of the industrial population, are returned as paupers, and that annually the taxpayers, already burdened with the immense cost of imperial armies, have to pay the enormous sum of \$150,000,000 to prevent these people from dying of starvation. Of this amount of free trade Great Britain alone contributes over one-third, or \$50,200,000. So terrible has the fight for existence become in these countries, that every year thousands who can scrape together a few dollars leave their homes in the old world and cast their lot with us on this side of the Atlantic. From the British Isles alone during the last ten years have come 1,333,247, and from the other nations of Europe 2,359,468, making a total of 3,892,715, equaling almost, in point of number, the population of Holland. With the same environments, with the same institutions to bring out their higher manhood, the citizens of the republic extend a welcome hand to this tremendous army of emigrants.

"But we are not ready to extend this same privilege of competition to those who still remain in other nations; to men who are living in different surroundings, who have not been educated up to the plane of the American workman, but who are content to slave on through life as their ancestors have done before them; who are chained to the forge, the mine, the loom and the despotic ruler, without hope and without future. Yet this is what free trade, or the de-nationalization of the United States, demands of the American workmen. To support this demand the workingman is made the victim of the most extravagant statements; he is told that the purchasing power of his wages will increase the moment he begins to compete even-handed with the 30,000,000 poorly paid workers of Europe. He is told the 'pauper labor cry' is a myth, and yet before him troops the gaunt host of 8,000,000 men and women dependent on charity. With wages varying from 50 to 150 per cent. higher in the United States than in Europe, the workingman pays less for his necessaries of life.

"Our experience vindicates the policy of protection; its strength lies in the prosperity it has given the nation; in the great industrial cities it has built up; in the prosperous and diversified industries it has founded; in the profitable home market it has given our farmers; in the varied employment it has given the men and youths of the country; in the homes and profitable work it has offered our kin beyond the sea.

"The cause of protection is the people's cause; it affects the vast masses of the people, and they must and will understand it. It cannot alone be studied in the lecture room. It can be studied in the light of the experiences of other nations, and in the experience of our own country.

"I cannot do better than quote from Mr. Ellis Robert's recent lectures before Cornell University, as he makes this point remarkably clear. He said: 'Beef, pork and poultry are cheaper with us, and so, the country through, are tea, coffee, and even sugar at retail. The Liverpool market fixes the price, not of grain in general, as is often said, but of our surplus. Our own price determines whether there will be any surplus or not. The American buys his cotton fabrics as cheaply as anybody. Anything made of wood which is higher here than elsewhere must be a curiosity or something which takes value from age. We are constantly exporting leather and many of its products. In many of the products of iron we excel

other nations, and in steel we are at the forefront. In iron our progress is the most rapid. Many of our tools are cheaper than the English. Tea and coffee are sold in this country cheaper than anywhere in Europe, and certainly much more so than under the heavy British duties. Sugar pays a very high duty in the United States, and yet such are the facilities for refining here that our retail prices are as low as those of Britain. At an equal distance from the mines coal is sold as cheaply in this country as in Britain. The most careful study will prove that all articles of prime necessity, including food in the essential varieties and the comforts of life, are cheaper here, not only in their relation to wages, but in money, than in any other country.

"When a family starts to set up a home in this country, it will find that for furniture and cutlery and the miscellaneous articles necessary, it will be charged as low rates as in any part of Britain or Europe. Plain pottery is as cheap, glassware twenty per cent. cheaper, coarse carpets and blankets are as cheap here as elsewhere. A like equipment for a house is to be bought for as little here as in Britain. The savings here on food will pay for the small share of the earnings appropriated to silks and woollens, of which the prices are higher. Rent is not more here than in Britain or Europe under like conditions, though our people demand better accommodation and naturally have to pay for it. Our studies show that for three-fourths of the usual expenditures of a family, the prices are in favor of the United States. The money cost is actually less here than in the land of lower wages, and with like comforts the expense is, on the whole, lower in this country. Even the exceptional articles tend downward in the United States as nowhere else."

#### AVERAGE WAGES HERE AND IN GREAT BRITAIN.

"Below I print what Mr. Carroll D. Wright, of the Bureau of Statistics of Massachusetts, calls the general average weekly wages paid to all employees in Massachusetts and Great Britain in 1883:

| INDUSTRIES.  | GENERAL AVERAGE WEEKLY WAGES PAID TO ALL EMPLOYEES. |               |
|--|---|---------------|
|  | Massachusetts.                                      | Gt. Britain.* |
| Agricultural implements.....                                   | \$10.25   | \$8.85        |
| Artisans' tools.....   | 11.80   | 4.89          |
| Boots and shoes.....   | 11.63   | 4.37          |
| Brick.....   | 8.63  | 4.16          |
| Building trades.....   | 14.99   | 7.21          |
| Carpetings.....  | 6.08  | 4.11          |
| Carriages and wagons.....                                      | 13.80   | 4.89          |
| Clothing.....  | 10.01   | 6.71          |
| Cotton goods.....  | 6.45  | 4.66          |
| Flax and jute goods.....                                       | 6.46  | 2.84          |
| Food preparations.....   | 9.81  | 2.72          |
| Furniture.....   | 11.04   | 7.96          |
| Glass.....   | 12.28   | 6.94          |
| Hats—fur, wool and silk.....                                   | 11.01   | 5.51          |
| Hosiery.....   | 6.49  | 4.67          |
| Liquors—malt and distilled.....                                | 12.87   | 12.66         |
| Machines and machinery.....                                    | 11.75   | 6.93          |
| Metals and metallic goods.....                                 | 11.25   | 7.40          |
| Printing and publishing.....                                   | 11.37   | 5.52          |
| Printing, dyeing, bleaching and finishing cotton textiles..... | 8.67  | 4.94          |
| Stone.....   | 14.39   | 8.58          |
| Wooden goods.....  | 12.19   | 5.67          |
| Woolen goods.....  | 6.90  | 4.86          |
| Worsted goods.....   | 7.32  | 3.60          |
| All industries.....  | \$10.31   | \$5.86        |

\* "Average" instead of "high" wages rate for Great Britain.

the wages in Massachusetts thus being nearly double the average weekly wages paid in the same industries and to the same class of employees in Great Britain."

#### Dry Rot in Business.

IT IS AN old saying that he who does not go forward goes backward, and, in this age of progress and enterprise, the saying is particularly applicable to business houses. The age is a progressive one, and he who would be successful must keep pace with it. Business methods are constantly changing, new ideas are introduced and enterprise takes on new forms frequently. It does not do to stand still or seek to rest on the laurels acquired in former years. The youth and energy of the country are alive and pushing, eagerly seeking business opportunities, and they are sure to crowd in wherever they see any indication of a willingness to falter in the race for business. The course is "free for all," and those possessed of the most aggressive and staying qualities will win the prize.

There are houses in the jewelry trade from which the spirit of enterprise seems to have departed. The names at the head of them are widely known and highly honored; in years past the men themselves were representatives of the energy and activity for which the jewelry trade is noted; every avenue of trade was canvassed by them, and no opportunity was lost for making custom and swelling the volume of business; they were keen, active, wide awake and fully alive to the requirements of the business. But, as age crept over them, and they found themselves fairly supplied with this world's goods, they began to take life easier, to be less energetic, and to consult their ease and comfort more, trusting to the reputations they had established to keep up their prestige and maintain their standing in the trade. In short, dry rot has seized upon them and is sapping the foundations of their reputations and their business. Younger blood has entered the lists against them, and is crowding them to the wall, as they, in their younger days, crowded out the "old fogies" who preceded them. They are virtually laid upon the shelf, and have little influence upon the tides of business as they ebb and flow past them. Many a firm which, in the early days of THE CIRCULAR, was the pride of the trade, has yielded to the ravages of dry rot, and their places are now filled by younger and more vigorous men. Others still exist, but the work of decay is plainly visible and the inevitable is near at hand. Still other respected firms have saved themselves from this fate by a transfusion of blood, admitting to partnership the young and faithful men who have served them long and honorably. The venerated names of the founders of the business are retained as a trade mark as it were, but the business itself is in the hands of the younger men, whose energy is of the present generation and in keeping with the progressive spirit of the times. We know of a number of firms that have thus passed through several generations, the names of their founders being preserved in the person of a son or a grandson, the reputation acquired by the first of the name combining with the young blood of his successors to keep the house in the van of the fight for success. But those who have depended upon reputations acquired in other years and under other conditions, have lived to see their business dwindle away and to fall into the hands of more active competitors.

The only cure for dry rot is young blood—new, fresh and vigorous. The young man who has his fortune to make is worth a dozen old ones who have made the fight and *are satisfied with their achievements*. Success is a coquette, who must be wooed with vigor and pertinacity before she will surrender; nor is she content to linger long in the arms of anyone; she wants to be pursued with ardor, and gives her pursuer no time for rest or idleness; the moment he begins to express contentment with his achievements she flits away to one more ardent in his devotions. Although coy, she may be easily won, but will not come for simply calling.

"It will be seen from this table that the average wages to all employees for the twenty-four industries considered in Massachusetts was \$10.31 a week, while that for Great Britain is \$5.86 a week—

All of which means that the necessary elements to win success are persistent energy, intelligent activity and unslumbering enterprise. Youth possesses these qualifications to a greater degree than age, and when age finds itself falling behind in the competitive commercial race it should ally itself with youth, and thus combine youthful vigor with hard-earned experience. Let youth supply the steam and age serve as the safety valve; let youth pursue the coquettish maiden, success, while age directs him with the advice of experience. So may honored names be preserved in the trade, and houses that would otherwise crumble away with dry rot be maintained in a career of usefulness and honor from generation to generation. But he who folds his hands and bases his claims to recognition on *what he has been* rather than upon *what he is* will find himself stranded upon the shoals of neglect, while the busy tides of active commerce pass him by unnoticed. This is a progressive age, and he who halts goes back. Old fogyism and dry rot are synonymous terms in this connection, and must yield their places to youth, energy and enterprise.

for excess of baggage, and not be subjected to delays and annoyances every time they change from one road to another. These same organizations are also filing vigorous protests against the discriminating tax imposed in some States on the merchants of other States in the shape of a license fee for travelers. Such laws exist in several States, and various municipalities require travelers to take special licenses in addition to the State license. The Supreme Court of the United States has decided such laws to be unconstitutional, but the several States go on collecting the license fees just the same. It will be a good thing if the trade organizations referred to can bring about the reforms suggested. It is a matter in which the entire commercial community is interested, and the jewelry trade, that sends out so many travelers, should not be laggard in lending its influence to secure the action necessary. Many of the travelers are members of the organizations named, but the merchants themselves, who will reap the greatest benefit by the reforms proposed, should give cordial and substantial support.

\*  
\* \*\*  
\* \*\*  
\* \*

### Gossip of the Month.

PEOPLE speak about their eyes being fatigued, said a distinguished optician recently, meaning that the retina or seeing portion of the brain is fatigued, but such is not the case, as the retina hardly ever gets tired. The fatigue is in the inner and outer muscles attached to the eyeball and the muscle of accommodation, which surrounds the lens of the eye. When a near object is to be looked at, this muscle relaxes and allows the lens to thicken, increases its refractive power. The inner and outer muscle are used in covering the eye on the object to be looked at, the inner one being especially used when a near object is to be looked at. It is in the three muscles mentioned that the fatigue is felt, and relief is secured temporarily by closing the eyes or gazing at far distant objects. The usual indication of strain is a redness of the rim of the eyelid, betokening a congested state of the inner surface, accompanied with some pain. Rest is not the proper remedy for a fatigued eye, but the use of glasses of sufficient power to render unnecessary so much effort to accommodate the eye to vision. But glasses must be adjusted with judgment or more injury than benefit is likely to result from their use. All persons who sell optical goods should inform themselves as to their nature so as to avoid mistakes. The eye is an organ that cannot be trifled with, and eyesight is altogether too precious to be left to the mercy of ignorant and unskilled persons. At the first indication of trouble with the eyes an oculist should be consulted.

\*  
\* \*\*  
\* \*\*  
\* \*

COMMERCIAL travelers have long complained that the railroads do not extend to them the traveling facilities and accommodations they should do, but, in fact, discriminate against them in some instances. They are required to pay full tariff fares as passengers, and are charged full price for extra baggage, while a traveling theatrical troupe or a cheap minstrel show can get reduced fares and liberal terms regarding baggage. As commercial travelers are the best customers the railroads have, being persistent travelers in all seasons, they feel that they are entitled to some consideration at the hands of the railroad magnates. New York merchants affirm that they have been discriminated against especially by some of the western roads, which make special rates for travelers for western houses. There are several organizations among the travelers that, among other things, are trying to secure a reform in this matter. What they desire is the privilege of buying thousand or hundred mile tickets that will be good on any road in the country at commuted rates; also to have some arrangement whereby they can commute

THE jewelry trade puts up with the poorest accommodations, and the greatest amount of inconvenience and annoyance in consequence, of any of the great commercial industries we know of. For the value and quantity of goods handled they are the poorest housed of any merchants or manufacturers in New York. Maiden Lane is the center of the jewelry trade; thence it radiates into Nassau, John, Courtlandt and Liberty streets, finding lodgment also in Broadway within these boundaries. This is one of the oldest sections of the city, Maiden Lane having been a cow path in the days when the city scarcely extended above Bowling Green, and the old Dutch settlers played skittles on the Green and smoked their pipes in phlegmatic contentment. Some of the buildings now used by the trade in Maiden Lane have the appearance of having been erected in those primitive days, and been subjected to such modernization as they would admit of. They are, generally speaking, low, narrow, badly lighted and illy ventilated, and possess few of the conveniences usually found in modern mercantile establishments. One of the greatest deficiencies is in the matter of light, an element so essential to the proper display of jewelry. There is also a great scarcity of room, and two or three firms are found huddled into one small, uncomfortable room that is scarcely sufficient for one of them. The owners of these rickety old buildings evidently think them all that can be desired, judging from the amount of rent they charge the occupants. Knowing the great desire of the trade to keep together, and having learned that they will submit to almost any extortion and inconvenience rather than seek commodious quarters elsewhere, the landlords charge the jewelers two or three times as much rent as they could possibly obtain from other tenants. If the jewelry trade was to remove to other localities, the old buildings would soon give place to modern business structures, and moderate rentals be charged for better accommodations. There is a splendid opportunity here for some capitalist, or a syndicate of capitalists, to put up one or more elegant, commodious and attractive buildings in Maiden Lane—after the style of the Wells, the Morse or the Field buildings, which are designed expressly for offices—for the use of the jewelry trade. Such a structure, nine or ten stories high, abundantly supplied with elevators, so arranged that each suite of offices would be bountifully provided with air and light, would be a boon to the trade, and at least a ten or fifteen per cent. investment for the capitalists who might build it. There has long been talk in the trade of seeking other localities, and some of the firms have removed to the vicinity of Union Square, where they find better accommodations, but the majority is wedded to its present quarters, and cannot be induced to leave a section of the city that has been devoted to the jewelry interests since the days when the original Dutch settlers swapped baubles and trinkets with the Indians for furs and for the land they

stood on. A mammoth office building would solve the problem, giving hundreds of jewelers opportunity to become tenants, thereby exchanging their present insufficient offices for better ones, and still permitting them to wander in their familiar haunts. Experience with this class of buildings has demonstrated that access to the upper floors by elevators is not inconvenient, and that, as a matter of fact, the ninth and tenth story offices are the most desirable, being so far above the noise and din of the streets, removed from their dust and dirt, and accessible to the pure air that comes sweeping up from the South, being cooled and purified as it kisses the waters of the Bay. An elegant, large, high office building, running through from Maiden Lane to John street is what the trade needs, and if it does not get it before long there will be a scatteration that will bring confusion.

\* \*

\* \*

\* \*

ONE would scarcely think of looking in the daily reports of the Chicago corn market for matters of interest to jewelers, but in a dispatch to *The Tribune* of this city we read the following:

"Jim" Love's Kohinoor dazzled the eyes of the cash corn crowd early this morning, but did not, at first, inveigle any of its members into buying September of him at 72½ cents. The rays from Frank Crittenden's smaller diamond modestly flashed across the room. John R. Bensley tripped about the crowd, suggesting, by his agility and archness a "coyly, tenacious maiden."

If the "bulls and the bears" will only spend their money for diamonds and other articles of personal adornment, we shall not object to their accumulating those vast fortunes that are said to be picked up so easily in the "wheat pit" or the "petroleum ring." But we greatly fear that those brilliant diamonds only serve as additional lures to tempt the young and inexperienced into stock gambling, taking chances on "puts and calls," or otherwise indulging the gambling spirit that has taken such strong possession of our young men. When "Kohinoors" are exhibited on the shirt-fronts of those who take life so easily as brokers seem to, young men are apt to feel inclined to shirk true manly work, and tempt fortune by rash speculation in the hope that they, too, may sport "Kohinoors" and be called "Jim" in the daily papers.

\* \*

\* \*

\* \*

IT WAS with rare pleasure that we noted at various times during the summer, the arrest of several European pilgrims who had undertaken, on their return, to smuggle into the country silks, satins, laces, millinery goods, precious stones, jewelry, etc. We are always glad to hear of the arrest of smugglers, not only because they are violating the law and defrauding the revenue, but because those who are successful throw upon the market a lot of goods that can be sold at low prices, not having paid duty, and legitimate dealers who do pay duties are forced to sell at a sacrifice in order to compete with them. Our laws in regard to tourists bringing foreign goods here are liberal enough to cover all that a person requires for his own personal use, but are intended to prevent the introduction of goods for sale unless duties are paid. The astounding elasticity of conscience possessed by some persons when dealing with the government presents a curious phase of human nature. It is thought to be a "smart thing" to overreach government officers, transgress the laws of the land, and thereby perpetrate an injustice upon the great body of taxpayers; for those who do pay have to make up the deficiency caused by those who do not. Yet persons who claim to be upright business men and good Christians will not hesitate to do a little smuggling on their own account when opportunity presents. We were once on the dock when a steamship arrived from Europe, and were interested in an effusive greeting bestowed upon a bright, handsome young lady by the friends who were awaiting her arrival. She was evidently of good family, educated, refined, and a belle in the society in which

she moved. As the merry group passed out of the gateway, we overheard the newly-arrived young lady say in French to a friend: "I have twelve dozen gloves sewed in my bustle." Of course, the detective had not looked *there* for smuggled goods. Now, that young lady had committed a grave offense in smuggling dutiable goods into the country, and possibly added perjury, or at least falsehood, in declaring that she had none. Yet she thought it only a good joke, and expected congratulations on having evaded the vigilance of the customs officers. And, no doubt, she was congratulated, for the worst of this whole business is that public sentiment does not frown upon this sort of thing. If it did, and every law-breaker was not only punished but held up to public contempt, there would be fewer fractures of the statutes. As it is, it is the laws and the law-makers that are objects of contempt, and those who successfully defy them are regarded as "smart."

\* \*

\* \*

\* \*

THE novelties in the way of lace pins are innumerable; they take on as many forms and designs as the scarf pins for gentlemen, which embrace everything, from a realistic house fly to a running horse at full speed, a bicycle or a grand piano. The ladies, too, have taken to wearing gentlemen's scarf pins for lace pins; two of these are fastened together by a light chain, and then made to cross each other as they are pushed through the lace. These are considered quite "the thing," especially for young ladies, and as all ladies are young ladies, it follows logically that these pins are very much worn.

\* \*

\* \*

\* \*

SOME genius has been calculating values as related to human energy in various departments of life, and as a result of his research announces that the British Poet Laureate can take a worthless sheet of paper, and by writing a poem on it can make it worth \$65,000; that's genius. Vanderbilt can write a few words on a sheet of paper and make it worth \$5,000,000; that's capital. The United States can take an ounce and a quarter of gold and stamp on it an "eagle bird," and make it worth \$20; that's money. The mechanic can take the material worth \$5 and make it into a watch worth \$100; that's skill. The merchant can take an article worth 25 cents and sell it for \$1; that's business.

\* \*

\* \*

\* \*

AN editorial writer in the *Art Amateur*, who should know better, says: "Some time ago I called attention to a trick not uncommon in the American jewelry trade, of selling for a real diamond what actually consisted of a thin layer of diamond neatly attached to a body of mere glass—a dangerous trick, for the made-up stone tested in its setting would readily pass as genuine." If he had said that such spurious diamonds were sometimes worked off on greenhorns by "bunco steerers" and "sawdust swindlers," he might have been somewhere near right. But when he declares it to be "a trick not uncommon in the American jewelry trade," he does a gross injustice to a large body of honorable importers and merchants. Imitation diamonds and imitations of all other precious stones are certainly used to a great extent in the jewelry trade; they are as much a part of legitimate merchandise as the pure gems themselves; they enter largely into the manufacture of cheap jewelry, for which there is a regular and legitimate demand. But these imitation stones do not deceive anybody, nor are they intended to; they are bought and sold at their true value, and hold relatively the same position to real gems that chromos do to oil paintings. There is a demand for both precious stones and imitations, and the trade supplies the demand.

But the idea that the American jewelry trade ever attempts to palm off imitation diamonds for genuine is absurd; it couldn't if it would, and wouldn't if it could. No one could be imposed upon by them unless his verdancy was of a kind that would imperil his safety when an intelligent cow was in sight. Editors of respectable papers should have more sense than to give currency to such absurd statements containing reflections upon a large and honorable class of citizens.

\* \*

\* \*

\* \*

WIT AND humor are indigenous to the soil of this country. Every man and every woman enjoys fun, and most of them are wits in their own way. Our most quoted American authors are our humorists, and every generation gives birth to one or more "funny" men whose printed witticisms are read with avidity and repeated with pronounced gusto. The prominent magazines, art and literary papers, the religious press and even the daily journals devote more or less space to the sayings of our funny men. Being a hard worker, with little time for social enjoyment, pushing and driving from morning till night, the average business man has little time to indulge his fancy, and so the printed fun that can be grasped in a moment of leisure, tickles his imagination and makes him pleased with himself and all the world, at least for the time being. The humorist comes to him as a relief to his cares, and he thoroughly enjoys him. Following the example of nearly every literary and artistic publication, we introduce with this issue a humorous department into THE CIRCULAR, made up from clippings from our exchanges. We should be glad to receive original contributions to this department; there is fun enough going on in the trade to keep it well supplied if it could only be recorded. We trust our friends will remember us when they hear a good thing, and use our columns for communicating it to the rest of their friends in the trade.

\* \*

\* \*

\* \*

SOME time ago Messrs. Fowler Bros. obtained a patent for crape jewelry, the specifications covering a peculiar method whereby the appearance of crape is given to jet stones. This is applicable to many forms of goods, and, as a consequence, crape jewelry at once became popular. Like all other good things, the idea was immediately stolen by some of the pirates in the trade, and imitations were at once put on the market. Fowler Bros. find that in order to reap the benefits of this invention, for which they had received a patent, they must conduct a lengthy and costly litigation against the infringers, and suits are now pending in the courts. This is another illustration of the utter disregard some persons in the trade have for the laws of *meum* and *tuum*. A patent is property; it has a cash value to its owner, and is just as much entitled to respect as are the contents of his pocket book. By what species of reasoning a man can excuse himself for appropriating one while he would respect the other we cannot understand. It was most excellent authority that declared "thou shalt not steal," and that prohibition applies as well to one kind of property as another. The laws of the country while they do not attempt to regulate a man's conscience, are lax in regard to patent pirates. If a thief steals a pocket book, he can be, if captured, speedily consigned to State prison; but the patent thief can only be reached through long, vexatious and costly law suits, and then the result is far from satisfactory to the one who has been robbed. The jewelry trade is a great sufferer in this respect, and there should be an understanding among all reputable members of it that they will not buy goods of one who infringes upon the rights of another. A patent should be held to be *prima facie* proof of property rights in the thing patented, and a notification to the trade that imitations of patented goods are being made should be sufficient to prevent the trade buying of the infringers. Owners of patents,

however, owe it to themselves and to the public to prosecute to the bitter end every patent pirate who steals their ideas and imitates their goods.

\* \*

\* \*

\* \*

New and attractive designs in gold goods for personal adornment were never so plentiful nor so attractive as this season. The manufacturers are entitled to great credit for the new and desirable designs they have devised for all classes of goods. There are various combinations with different colored gold, wherein superior workmanship goes hand in hand with artistic conception, and the result is such elegant and tasteful jewelry as the finest lady in the land might covet. These articles do not need the addition of precious stones to make them attractive, but possess a beauty all their own. Brooches, ear rings, bracelets, locket, etc., are to be found in most attractive varieties, and are now much worn; chatelaines take on as many and as fanciful forms as do the ladies for whose adornment and convenience they are intended, while the variety of styles in ladies' cuff buttons are innumerable. A glance at the show windows of dealers who take their cues from prevailing fashions, is proof positive that gold jewelry is again the style.

\* \*

\* \*

\* \*

BUT there is a degree of luxury and elegance about jewelry into which precious stones enter that never grows old and is never fully satiated. Fashions may change in everything else, but precious gems are never *passé*; the forms in which they are worn are subject to changes, but the gems themselves are always fashionable. American ladies are more fastidious regarding them, however, than those of any other country. In Europe, diamonds are handed down for generations in the precise forms in which their original owners had them set, but here the setting is changed as frequently as the fashion in settings does or as the owners of the gems can afford it. But precious stones are for the wealthy, while chaste and artistic gold goods can be worn by every one, and, at the same time, there is the widest latitude in its selection for the display of the peculiar taste of the wearer. Both classes of jewelry are now much worn; each class has its place, and the jewelry trade is prepared to supply the most critical taste at the present time in either class.

\* \*

\* \*

\* \*

WITH all the abuses that are complained of by the jewelry trade, it is no worse off, if reports are to be depended upon, than other industries. Ask a dry goods dealer how trade is and he will respond "business is fair, but it is all cut to pieces;" the hardware men sing the same song; insurance companies vow they haven't made any money for five years because "rate cutting has knocked profits higher'n Beecher's Bible;" as to the job printing business, we know it is "cut all to pieces;" and so it is in regard to every industry whose special organs we find among our exchanges. The cause of all this is excessive competition, and this is what ails the jewelry business. "Competition is good for trade" within certain limitations; when it produces goods in excess of demand, competition is likely to result in unbusinesslike practices, the manufacturers adopting unusual methods to work off their goods. When a bad practice once becomes a custom it is difficult to enforce a remedy; nothing but a revolution can accomplish the work of reform. Such a revolution is produced either by a panic which consumes capital and so lessens competition, or by a season of prosperity which absorbs the surplus product and re-establishes the equilibrium between supply and demand. On the whole, the jewelry trade is no worse off than other industries, and those engaged in it had better "bear the ills

they have than fly to others they know not of." "A bird in the hand is worth three of a kind;" "an honest man gathers no moss;" "a rolling stone is the thief of time;" "the shoemaker sticks to his last," and other homely proverbs will suggest themselves to enforce our text, that there are many worse lines of business than the jewelry trade.

\* \*

\* \*

\* \*

THERE were an unusual large number of robberies of jewelry last month from individuals. If thieves really feel that they must have jewelry, it is pleasant to note that they are transferring their attentions from the trade to individual owners of it. For a long time the thieves victimized the dealers throughout the country, but last month they seemed to be devoting their time largely to robbing private owners of jewelry. This is good for trade, in a certain sense, creating a demand for more jewelry to supply the place of that which finds its way to the melting pot in the attics of the pawnbrokers. It is better for the trade and the public in general, however, when these depredators upon private property are captured and consigned to prison walls, as has been the case with several recently; the trade breathes freer whenever a thief is "sent up," for the chances are that he has raided some member of it at some time or was contemplating doing so. We noticed in the daily papers in one day last month accounts of four different robberies of jewelry, and in no instance was a dealer the victim, a circumstance so remarkable that it is deserving of being recorded.

\* \*

\* \*

\* \*

A FOREIGN exchange calls attention to a singular barometer said to have been discovered by some member of the Araucarian race, which inhabits the southernmost province of Chili. It consists, we are told, of the cast-off shell of a crab, which, from its curious application, is called the "Barometro Araucano." The dead shell is said to be extremely sensitive to atmospheric changes, remaining quite white in fair, dry weather, but indicating the approach of a moist atmosphere by the appearance of small red spots, which grow both in number and in size as the moisture in the air increases, until finally, with the actual occurrence of rain, the shell becomes entirely red, and remains so throughout the rainy season.

\* \*

\* \*

\* \*

EDWARDS, an authority on the subject, makes the statement that a few years ago the signet ring of the famous Turlough Lynnoch was found at Charlemont, in the county of Armagh, Ireland. It bears the bloody hand of the O'Neils, and initials T. O. The signet part of the ring is circular, and the whole of it is silver. O'Neils had been Kings of Ireland and were also Earls of Ulster. The symbol of the province of Ulster was a bloody hand. Fergus, the first King of Scotland, was descended from the O'Neils. King James the First made this bloody hand the distinguishing badge of a new order of baronets, and they were created to aid by service or money for forces in subduing the O'Neils.

\* \*

\* \*

\* \*

THE season of weddings is upon us, when the young of both sexes of the human family are seeking their mates. As a rule (having numerous exceptions) a person gets married but once in a lifetime, and regards that event as one to be commemorated as a red letter day in Ilfe's calendar. Custom has decided that presents of various kinds shall be showered upon the newly wedded couple by their

numerous friends, and, very naturally, the skill of gold and silver-smiths is taxed to bring forth articles of use and ornament that shall combine excellence of workmanship with artistic designs. Our workmen have proved equal to the occasion, and elegant goods of every description, suitable for wedding presents, may be found conspicuously displayed in the stores of our merchants. A glance at these is sufficient to tempt a man to propose forthwith to his regular-stand-by-girl in the hope that his friends will be liberal in sending in presents so attractive and that are "so handy to have in the house." We did think of enumerating some of the most attractive goods of this kind, but the list is so long that we have not space; and, besides, where all are so deserving of commendation it would be unfair to discriminate. To all who contemplate matrimony, or who are called upon to celebrate the marriage of friends, we can truly say you will be wise to visit those stores where gold and silver-ware form the staple articles of trade.

(Copyright, New York. All rights reserved.)

### Russian Reproductions

At the Metropolitan Museum of Art.

[BY JOHN W. MILES.]

Continued from Page 292.



Scythian Gold Ornament.

EVERAL OF the little gold ornaments that were attached to the garments of the Scythians will be found illustrated in initial letters during the progress of this description. Similar pieces are not known to exist elsewhere. They were made of thin plates of gold, and as many of them have been found precisely alike it is thought that they were produced by means of dies. A large number were unearthed at the tumulus of the Koul-Oba, lying in little heaps upon the ground beneath the nails upon which the clothing was suspended at the time of burial; the clothing itself, with the exception of some tangled masses of gold thread, having long since mouldered away. A great quantity was also found in the tomb of the "Reine de la Masque," of which mention has been made. Nineteen of these dress ornaments were selected for reproduction, and their *fac-similes* are in the museum collection.

Of the weapons carried by the Scythians, the lance and the bow were the most prominent, although a short sword was also used. For the latter a sheath of leather was provided, covered on its outer side with a thin placque of metal. For the common soldiers this placque was most probably of iron or bronze, but for the kings they were made of pure gold richly decorated. Two of these sheaths or scabbard covers are illustrated in figures 6 and 7. They are similar in shape and very handsomely worked in *repoussé*. That represented in figure 6, found at Koul-Oba, is 24 inches long. At the extreme tip of this piece is the mask of a lion followed by a species of leopard attacking an antelope or gazelle. Then comes a stag brought down by a lion and a griffin, and, in the separate section formed at its widest part, a hippocampus. Near the tip the word 'IOPNAXO (? Иорвашо) occurs in *repoussé* letters.

That the figures have a special and prominent significance cannot be doubted. The work is Greek, and Greek art, wherever applied, always had a meaning. It was not only made *by* a Grecian but it was also made *for* a Scythian, and this is plainly apparent from the character of the figures themselves. As the people of the United States have chosen for their emblem the eagle with extended wings, as the English have chosen the lion, and the Chinese the dragon, so also the ancient inhabitants of Panticapæum selected the griffin, those of the Caucasus the goat, of the Koudan the boar, of Cherson the stag and of Panagoria the lion. In the light of these facts the

sagacious interpretation of Dubois appears quite probable when he explains these scenes, so manifestly emblematic, by the theory that the griffin of Panticapæum and the lion of Panagoria throwing down the stag of Cherson was intended to symbolize the victories of a Leuconide over his enemies of the peninsular and the warrior people of the Caucasus. All of these animals appear more or less frequently, and the griffin especially is rarely forgotten. The name of ΠΟΡΝΑΧΟ which appears at the tip may, indeed, be that of the maker, but as we can hardly make a Greek name of it, it was more probably that of the person for whose use it was originally intended. Its period is that of the fourth century B. C.



Scythian Gold Sword Sheath,  
Figure 6.



Scythian Gold Sword Sheath,  
Figure 7.

The sheath covering illustrated in figure 7, although somewhat smaller (21 inches long) than the one we have been considering, is much the finer of the two, not only artistically but also in execution. It was found in the Nicopol tomb and belongs to the same age as the other. It is hardly possible, however, that it could have been made by the same hand, as it so far excels the plaque of Koul-Oba as the work of the master excels that of his pupil. The five scenes depicted upon the body of this piece are those of combats between Hellenes and barbarians—probably Scythians. The leaders of the two forces are at the widest part. From the dress, helmet and arms of the first figure there can be no doubt that it represents a Grecian, and, for the same reasons, we may safely class the second figure as a Scythian. The former wears a plumed helmet, a short corslet and over it a coat

of mail. Greaves are upon his legs and a short sword hangs at his side, suspended by a band passing over the right shoulder. As he presses eagerly upon the enemy, he turns to encourage and bring forward his troops, utterly unconscious of the Scythian leader stealing upon him with drawn sword. The sword here represented is such a one as might be carried in a sheath of the style of the plaque under discussion, the widest part covering the hilt and handle, and the blade resting beneath the narrow portion. No sheath, however, is seen upon the figure, nor any other weapon except a bow in the left hand. In the second group a Grecian is endeavoring to assist to his feet a wounded companion and at the same time shield him from the fierce attack of a barbarian. In the third scene the barbarian has fallen upon his knees but still defends himself with an axe, while a fellow warrior, mounted, is vainly striving to raise his horse who has stumbled. Two Grecians are given in the fourth scene, one of them apparently wounded and the other in surgical attendance upon him. The wound is evidently one requiring the use of both hands as the attendant is obliged to hold his knife in his teeth to leave his hands free. In the fifth scene the barbarian has been thrown from his horse and is being dragged rapidly over the ground by the bridle. He has no visible opponent, probably for lack of space, but a Grecian helmet is given as a suggestion of one. The whole series is bordered by a cable, outside of which are holes punctured for attachment to the leather scabbard. At the termination of the two ends of the cable are two griffins afrontes with a flower of the myosotis over each. The other compartment holds a large griffin devouring a stag, the head and horns only of the latter appearing to the view, and perhaps that was all that was left of him.

In the work upon this piece one is forcibly impressed with the exquisite tact of the artist in leaving the result of the different struggles undecided. No warrior among them all is wholly victorious, nor does it appear that either side are unequally represented in the quality of courage. It would scarcely be possible for the patriotism of a Greek artist to depict his own countrymen as otherwise than brave, neither would it be politic for him to portray the Scythians as vanquished, since the piece was made for a Scythian king. In leaving the award of glory an open question, the artist has displayed a *finesse* extremely delicate and sagacious. He has, however, complimented the Scythians in the griffin of Panticapæum, who is certainly having the best of it with the stag of Cherson, a subject conveying no dishonor to Greece. We may also observe with admiration the masterly manner with which the grouping is handled, in its accommodation to the space available. There is no diminution of size in the figures occupying the narrowest part, and, what is still more skillful, there is no lack of life and action at these points. Whether the scenes here given were intended as a record of some historical event, or whether the principal personages were meant to be portraits, we have no means of determining. However, the artistic character of the work renders it one of the most valuable of the few pieces belonging to the period which we possess, revealing alike the skill and imaginative genius of the Grecian goldsmith. It is a fitting introduction to the object which we are about to examine and which was probably executed by the same artist.

By referring to the scene depicted upon the vase of electrum, illustrated in figure 4, we will find suspended at the left side of the Scythian warriors a bow held in a case, which covers something more than half the weapon. This case, like the sheath for the sword, was made of leather, and had also an exterior plaque of metal in order to give it firmness. It had, besides, a smaller pocket for arrows, thus serving in the capacity of a quiver as well as a bow case. Among a people famous for excellence in archery, and depending upon the arrow more than upon any other weapon for success in war, we may well conceive that the bow case, or Goryt as it is called, was an object of more than usual importance. Next to his horse, the bow and its receptacle was a part of the Scythian himself, and an object of his most careful solicitude. It would be natural, therefore, that the Goryt should receive a large amount of that magnificent and ori-

entally elaborate ornamentation which prevailed in their horse accoutrements, and, in case of royalty, in their garments. We can see in the vase scene that, although ornamentation is applied nearly everywhere with luxuriant extravagance, the Goryt bears decorations equal to any other part of the equipment. It is a most remarkable example of this important piece which I illustrate in figure 8—a placque of gold weighing almost 44 zolotinks and measuring 18½ inches long and 11 inches wide at its widest part. It needs but a glance at the beautiful *repoussé* work upon this Goryt, to determine its date as that of the highest stage of Greek art—the age of Praxiteles. The rich Ionic ornaments, the serpents' tongues and prophylactic emblems, win our admiration in a no less degree than the two mythological scenes filling the main part of the surface. All means of identifying the artist who executed this wonderful work is, of course, beyond our reach. We can only judge of him by the character of the work itself, which seemingly proves beyond question that he was a Greek, and not only that, but also a Greek possessing the most elevated Attic culture, in combination with a perfect knowledge of Scythian customs. Hence we see upon the upper edge a stag, which has fallen a prey to a lion and a panther, another lion which is attacking a boar, a female panther tearing a deer, a lioness attacking a steer, and an incomplete animal which may have been intended for a dog. These are all in small proportions. Occupying a prominent and quite extensive space in the lower projecting part we find a group much larger and more carefully executed of a male and female griffin struggling with a panther. Even if the ingenious explanations of Dubois are incorrect, we certainly cannot dispute the griffin of Panticapaeum nor deny the almost invincible proof by which its prominence settles the destination of the piece as a decoration for the Goryt of a Scythian king. However, it is no part of my intention to discuss questions of more interest to the archeologist than to the goldsmith, and we will, therefore, at once review the principal scenes covering the larger portion of the placque. We will first, then, examine these groups as they are, after which I will give in full, without apology, the entire myth to which they refer, for I am quite sure, from a most careful investigation, that it will be found in few, if any, of the mythological works in the English language.

The lower scene is divided into two compartments by a curtain, on the left side of which are represented four female figures. There can be little doubt as to the principal personage in this group. She not only sits upon a seat more elaborate than those occupied by the two other sitting figures, but she also rests her hands upon the shoulders of her companions, as if rightfully claiming both their fealty and friendship. The position of the entire group is one of expectation, but on the face of the principal personage there is also an expression of sorrow and anxiety, not unmixed with fear. They are evidently awaiting the termination of some event that fills them with the deepest apprehension—an event depending upon the result of what is taking place on the other side of the curtain, and which directly and intimately concerns the principal person. That is the expression which the artist doubtless designed to give and certainly he has succeeded admirably.

Turning now to the companion picture we find here also the prominent figure clearly defined, although two others share that distinction in a slightly lesser degree. The bearded man sitting upon an elaborately worked chair, or throne, bears the expression in both face and posture of a calm attentive judge. The young man who has thrown his shield and arms upon the ground before him and allowed his garment to fall below his waist, is evidently conducting an investigation with an eagerness which belongs to youth and to a direct personal interest in the circumstances. In his left hand he holds a shallow casket from which he has removed the cover with his right hand. The bearded men on either side of him are probably members of a lower order. They are both supported upon crutches (in one the crutch is hidden by the drapery of his clothing, but the position of the body would require such a support and undoubtedly received it) and one having a cane in addition. They are being examined and

questioned by the young man regarding the contents of the casket. The remaining figure is of a woman carrying in her arms a babe which she has covered with a portion of her dress. Upon her face there is an expression of hesitancy and sorrow. The sorrow is of a less dignified character than that of the woman in the first group. There is less nobility about it and more evidences of a lack of will to patiently endure.

The scene in the upper picture is entire. There has been a conversation of some nature between the young man who is standing and the young woman who is endeavoring to run away. This conversation reached at last a point where the anger of the young man



Scythian Bow Case, Figure 8.

could no longer be restrained. He springs to his feet and drawing a short sword evidently intends the death of the woman, but is prevented by the man sitting by him who grasps his arm. The woman, with terror depicted upon every line of her face, attempts an escape, but is, in her turn, held captive by another woman occupying a part of the seat just vacated. The scene is intensely tragic and full of pathos. On the left are two more female figures witnesses of the exciting scene just mentioned. One of these holds to her breast a boy, who has fled to her affrighted at the impending deed of blood. Although a part of the group and attentive to the proceedings, they appear less actively interested in the result than might be expected,



but, as we shall see later on, this arrangement was a part of the sagacious plan of the artist. At the extreme left of the group a young man is teaching a boy the use of the bow, and both of them are utterly unconcerned with what is taking place in close proximity. Again, upon the right, we see a bearded man sitting, and hanging his head in evident sorrow. The expression of painful regret and grief, which veils his countenance, is most pathetic. In front of him, in a reclining position, is a young man, holding in his right hand a sheathed sword, to which is attached a ribbon band. His shield and armour lie upon the ground behind him. He, too, takes little interest in the tragic scene that is being enacted before his eyes.

Examining the piece still more closely we are compelled to arrive at the following conclusions:—the woman in the group of four females in the lower picture, and the woman flying for her life in the upper scene, are one and the same person; the judge who sits with his right arm resting upon the back of his chair, and the left arm over his head, can be no other than the sad-faced figure on the right in the upper group; the youth, who is holding the casket and seeking an explanation of its contents, is again seen in the upper representation with drawn sword and angry countenance, and the other women in the lower left hand group are all duplicated in the upper picture. The connection between the two is thus proven, and we may reasonably consider that the passionate occurrence of the upper scene is the direct result of the investigation taking place in the lower one. Having gotten from the piece something of what it itself teaches us, we may now apply the myth of which it is an illustration.

Alope, the beautiful daughter of Kerkyon, was loved by Poseidon (Neptune). In great fear lest the liaison should be discovered, Alope caused her babe to be exposed upon the mountains, where he was suckled and preserved by a mare. Soon after, the child was found by a shepherd, who took him, together with the raiment and jewelry found upon his person, to his own house, but afterwards gave him to a second shepherd, retaining, however, the valuable robes and ornaments. Upon this, a quarrel arose between them, as the second shepherd insisted that the articles should be delivered with the child, and the dispute at last grew so fierce that it was decided to leave the matter to the judgment of the king. Accordingly, this was done, but Kerkyon, when he saw the royal garments and other objects, recognized them as belonging to his daughter Alope. Hereupon, an investigation was instituted, which terminated in the confession of the nurse, who had exposed the babe. The judgment of the king decreed that the child should be again exposed, and some say, that he himself slew Alope, and others, that he pined away with grief at the disgrace which had fallen upon his name and family. By a fortunate reiteration, the mare again suckled the boy, and the same shepherd again found him. This singular repetition so strongly impressed the shepherd that he conceived for the child the paternity of a god, and reared him with all the respect due to a divine origin. The waif thus rescued was called Hippothoon (*ἵππος*—a horse, and *θετὸν*—adopted by) and figures much more prominently than his mother in Grecian mythology. It is evident that the artist of our placque accepted that rendering of the myth which records Kerkyon as being consumed with sorrow for the indiscretion of his daughter, and more especially since that interpretation agrees with the following conclusion of the legend, and with the illustrations given upon the Goryt. Theseus, himself a reputed son of Poseidon, included among his many wives and favorites the heroine of our story. It is most probable that this relationship existed shortly previous to the discovery of Alope's lack of faith, and that the appearance of the babe, with its attendant revelations, provoked a violent quarrel between them. If Kerkyon, who was a famous wrestler, was slain by Theseus, who was still more famous in that exercise, it must have been an event taking place subsequently to the occurrences which we have before us upon the placque. Accepting, therefore, as we must, the version of our artist, in order to understand the ideas which he has so exquisitely portrayed, the future fate of the principal personages can be briefly stated. Poseidon, whether jealous of the

attentions of Theseus or on account of her own request for succor, changed Alope into a spring, and a fountain, bearing her name, long existed in Greece. Pausanias, in his *Itinerary*, also describes a sepulchre erected to her memory, which he himself saw on the way from Eleusis to Megara. Hippothoon, having arrived at manhood, besought Theseus to restore to him the kingdom of his grandfather (Kerkyon), and the hero, in consideration of their relationship, complied with his request.

Without discussing too exhaustively the questions arising from this legend, that more particularly belong to the realm of the mythologist, such is the story which our artist has selected for his subject. That it was a subject fitly chosen we may well conceive, since Poseidon was the god of horses, and the Scythians were preeminently a nation of horsemen. Any myth, therefore, which in any manner referred to this god, could not be otherwise than acceptable to the people holding him in such high estimation, and, in selecting that of Alope, the artist has hit upon one of the most beautiful and tragically poetic of them all.

It needs no especial perspicacity to identify the figures upon our placque with the principal persons of the legend. The bearded man of sorrowful mein is Kerkyon, the young man with the open casket questioning the two disputing shepherds is Theseus, while the nurse, still holding the infant Hippothoon, either has confessed or is tormented with the growing necessity for doing so. The others may be classed as friends or near relatives of the chief personages and conversant with the dishonorable secret.

Aside from the perfect execution of the work, we must also admire the keen perception of the artist in the arrangement of the figures, and the delicacy with which he has expressed the ideas belonging to the myth. In the upper scene especially he has relieved the intense strain upon our sympathies, excited by the tragedy occurring in the central portion, by representing at either end scenes of a more calm and peaceful nature, which, though a part of the picture, soften the harshness of a tableaux which threatens to result in an appalling crime. I commend an examination of this piece to those who think that the term "fine art" should apply exclusively to the art of painting and the art of sculpture.

(To be Continued.)

### Changing of the Dials.

NOW that the question of standard time seems definitely settled, despite the defection of Louisville, the attention of railroad men and scientists, the two classes most concerned in the above reform, is turned toward the question of dial reform. Instead of our two divisions of twelve hours apiece, which now make up the day and night of twenty-four hours, the advisability of numbering the hours consecutively from one to twenty-four is being discussed. Already in many jewelers' windows may be seen watch faces provided with a double ring of figures, the inner one of which shows the figures 13 to 24. Though to some extent this meets the primary objection to the change of hours, namely, that the twelve hour watch movements would be rendered useless, it does not altogether work simply and satisfactorily. Another system has been invented by Dr. Whitney, a Philadelphia enthusiast. This needs a complete distribution of the figures on the dial, and in this particular only is bettered by the form above described, which can be adapted to any existing watch-face. According to the new method the figures 1 to 24 are arranged as it were upon an endless band which crosses on itself so that the figures 6 and 18 are in contact. Thus it will be seen that there is an outer rim with the figures 1, 2, 3, 4, 5, 18, 19, 20, 21, 22, 23, 24, and an inner rim with the figures 13, 14, 15, 16, 17, 6, 7, 8, 9, 10, 11, 12. The 13 of the inner rim is under the 1 of the outer rim, and the other numbers follow in the order given. Starting our twenty-four hours at midnight, one can use up half the

outer rim until the morning hour of the work-a-day world is reached. at six o'clock one can shift to the inner rim and use this throughout the day until the approach of dusk warns us that we have changed again on the outer rim, which is accordingly used until midnight. It may be remarked that the day would have to begin at midnight instead of in astronomical fashion at midday. Were this not the case it would be one day of the month in the morning and the next day in the afternoon.

This plan of arranging the dial has secured the warm commendation of Sanford Fleming, who was one of the chief movers in the introduction of the standard time system. There seems but little doubt that at the international convention shortly to be held the subject will receive full discussion, and it is hoped that the railroad companies will make the first move by adapting it on their timetables, thus doing away with the necessity of the awkward and puzzling "A. M." and "P. M." It has been suggested by the inventor of the above-described dial that to satisfy the conservative-minded ones who would still cling to the system of their forefathers and would affect to be puzzled by the new notation, the following plan should be adopted: A foot-note might be printed at the bottom of each page of the time-table: *Note:* For P. M. hours, read 12 less. Thus a time table would read: "Trains arrive: From Pittsburg, 6.10, 11.20, 19.30 and 22.20 daily. From Washington and Baltimore: 6.30, 6.40, 13.20, 15.40, 15.50, 17.30, 21.20, 22.20 and 22.35.

*Note:* For P. M. hours, read 12 less."

---

### Tortoise Shell.

THE horn-like epidermoid plates which cover the dorsal buckler or carapace of the sea tortoise, are in some species so fine and of such beautiful colors as to be employed for various purposes of art. It is only those, however, of the hawk bill (*Eretmochelys imbricata*) and caret species that possess any great trade value; the plates being stronger, thicker and clearer than in other species. There are usually thirteen plates on the carapace called, collectively in trade, "the head"—four on each side and five on the back, the last bent in the center. Of the side plates, the two middle are the most valuable, being the largest and thickest; those on the back and margin, known as the "hoofs" or "claws," are comparatively of less value. There are twenty-four marginal pieces, which are termed the "feet" or "noses." The *lamellæ* or plates vary in thickness from  $\frac{1}{8}$  to  $\frac{1}{4}$  of an inch, according to the age and size of the animal, and weigh collectively from 4 to 6 pounds or upward. In an animal of ordinary size, about 3 feet long and  $2\frac{1}{2}$  feet wide, the largest plates weigh about 9 ounces and measure about 13 by 8 inches, and are  $\frac{1}{4}$  of an inch thick in the middle.

Tortoise shell is usually detached from the carapace and bony framework by placing heat below, or sometimes by soaking it in boiling water. In the West Indies the plates or blades of tortoise shell are removed by burying the carapace in the ground or sand for ten or twelve days. When taken up the blades fall off, and the thirteen dorsal pieces are easily collected. A small hole is bored in each, so as to string them together, for no experienced buyer will purchase a case of tortoise shell unless the whole of the shell is thus presented. The "feet" or "noses" of the tortoise shell are chiefly in demand in China.

The blades of the hawk bill or imbricated turtle are very transparent, and more beautifully mottled than those of the caret turtle; the scales of the latter are thinner, and are not used for the same purposes, but employed for veneering and inlaying work. The shell of the hawk bill has a blackish-green color, with yellowish spots, while the color of the plates of the caret turtle is blackish, with irregular transparent spots of golden yellow and veined with red and white, or of a brownish-black of various shades. The plates of the green or edible turtle (*Chelonia mydas*) are thin and flexible, and of slight

manufacturing use. The scales of the loggerhead turtle (*Thalassochelys caouana*) are of a dark chestnut brown, very thin, and neither clear nor beautifully colored, hence they are of little value; but latterly some use appears to be made of them, for the English imports of turtle shell (as it is named in contradistinction to tortoise shell) have averaged in the last four or five years \$30,000 in value.

Tortoise shell is worked upon like horn, and is usually softened or rendered plastic by placing in boiling water containing a handful of salt to the quart; by this means it is rendered so soft that it can be pressed into moulds. The moulds employed are double, so as to contain the shell between them. When all is ready the mould is put into a press, and the upper half gently pressed down upon the shell. The whole is then put into boiling water, and as the shell becomes more and more softened the upper half of the mould is from time to time screwed down, until at length the shell is completely pressed into the lower mould, so that any devices that may have been engraved or embossed upon the two halves of the mould leave corresponding impressions upon the shell. When two pieces of tortoise shell are to be joined together the two edges are beveled off, so that one inclined edge may lie on the other. The edges are then scraped perfectly clean, contact with the fingers or any greasy substance being carefully guarded against. A piece of paper is then bound around the overlapped edges and fastened with a string. A pair of tongs or pincers are then heated and applied to the shell, one jaw above and the other beneath, by which the shell is grasped throughout the length of the seam or overlap. By holding it for some time in this position the heat of the iron softens the shell and causes the two pieces to unite or weld firmly. For modern uses thick tortoise shell is more valuable than thin. The uses of the article for ornament are varied, and the number of articles made from it are very numerous. Brown and light colored shell is imported from India and China to France for fans, the former costing \$6.25 per pound and the latter as much as \$20. In China and Japan very beautiful cups and saucers and fancy boxes are made from this material.

Tortoise shell has always been a favorite material for combs, but it is only in recent years that jewelry made from it has become fashionable in Europe and America. England imports annually large quantities of tortoise shell, and, according to Mr. P. L. Simmonds, from whose "Commercial Products of the Sea" these notes are borrowed, maintains the monopoly of this artistic material. The material is received from India, China, the Eastern Archipelago and Pacific Islands, Australia, the West Indies, South America and Africa.

---

### Some Facts About Amber.

THERE ARE in this city several houses that import amber extensively and work it up into various forms for commercial uses. Some of their productions are of a highly artistic nature and very valuable. There are amber enthusiasts, who revel in a peculiar piece of amber as a lover of precious stones gloats over a fine diamond. A reporter encountered one of these recently in the midst of his collection and elicited the following information regarding this beautiful substance:

"Yes," he said, "I have a special liking for amber, and I have just returned from a trip which I made to the amber district on the Baltic. All the amber of commerce comes from there now, although amber is found in many parts of the world—in China, in Japan, since recently in Patagonia, and from time to time in the United States. It is a peculiar fact that the amber found here and in Patagonia is particularly fine. It is of the transparent kind, or, as we say in commerce, clear amber, but it is much darker than the Baltic clear quality, of a reddish yellow, approaching the color of a fine Oriental topaz. Pieces of this fine quality have been found in Amboy, N. J. I was very much struck with one fact in East Prussia: All the amber that is found is in a vein of bluish green sand. I picked out a piece

myself, and showed it to a friend who knew something of mineralogy, and he pointed out to me fine particles of mica glittering in the sand which adhered to the piece, for I kept it unwashed on purpose. He said to me that he thought this sand was in reality decomposed aluminous clay. Now at Amboy there is, I understand, a large deposit of this clay which is used extensively in the potteries of Trenton. It may be that the pieces of amber found at Amboy were in a bed of this clay decomposed by the action of the sea in past ages. However that may be, it is certain that on the southern shores of the Baltic the men who worked for this amber by raking the seaweed after storms, long ago came to the conclusion that the precious article was rolled out by the tide from this peculiar bluish green sand. So they follow the veins of the sand and mine them regularly. The government assumes to own all the amber and farms the work out to one contractor, who pays 300 thalers each working day for the privilege of working it.

"I visited first the village of Palmricken, which is about three hours' ride by rail from Konigsberg. There were about 600 inhabitants who were supported entirely by amber mining. There was one central shaft which went down about 100 feet, and there were different galleries and cross-cuts, just like streets and cross streets. I think there must have been forty miles of them. The workmen dig into this sand, and fill small tram cars that hold about 500 pounds. These are run to the elevator and hoisted up by steam. The sand is then washed in a sluice just as in gold mining, the pieces of amber being stopped by nets of various meshes at different intervals. Then skilled workmen take the pieces and assort them according to size, shape and quality. Pieces containing foreign substances, so dear to the collector, are put on one side. At the first handling they are considered inferior until further examination shows the exact nature of the inclosed substance. Pieces that are cracked are of little value and generally go to the varnish maker. They could be utilized in a much more remunerative way, for a delicate perfume is made in Spain and Italy from this substance. But this is done nowhere else. I got Colgate to experiment with scraps from our workshop, but he did not succeed. Large pieces are much more valuable than small pieces. A lump of amber weighing a pound would bring \$50, while one weighing thirteen pounds would be worth \$5,000. There is in the National Mineralogical Museum at Berlin a piece weighing nearly fourteen pounds. The shape also is a consideration. An oblong piece is worth more than a round piece, and a well-shaped round piece is worth more than an ill-formed round piece.

"The cutting is chiefly done in Dantzig. Here this same man that contracts with the government has an army of work people. He has 500 men employed in one branch alone, making mouth-pieces, and 500 more employed on beads and jewelry for Russia alone. He takes their work for the whole year and disposes of the whole in a week in the great fair at Nijni Novgorod. Then he has many more workmen who manufacture beads for China, Japan, India, Turkey and Arabia.

"You must know that the two great divisions of amber are into clear and cloudy. Now it is a peculiar fact that the Americans agree with the Turks and Arabs and Persians in preferring the clouded, whereas Europeans esteem particularly the clear, and so do the Chinese and Japanese, and the non-Mohammedan inhabitants of India. A Mogul of Delhi will have his prayer beads clouded, and as red as he can get them. But the wives and daughters of Brahmins, Banians and Rajpoots will take nothing but the clear. They especially delight in cylinder ear rings an inch long and as thick as the middle finger, and have some superstitious idea that these prevent earache and headache. Such ornaments are light in spite of their size and do not pull the lobe of the ear down. The demand in the East is so great that it never has been supplied. In America the amber mouth-piece is the one article for which there is much inquiry. We are endeavoring to combine the two qualities in cameo-like ornaments, with a background of the clear, and a decoration in the cloudy cut in high relief. We cut medallion portraits, fruit, flowers, etc., and

unite the two with mastic. And we have many sets of amber jewelry that are really fascinating. But there is on the part of the public a liking for gold jewelry, and amber for personal decoration is the choice of a few very refined people. There is a lady in New Jersey, Mrs. E. A. Smith, who is a most passionate lover of amber. She has a set of beads which she wears over black velvet in a peculiar way. The beads are arranged in concentric curves so as to form a curious covering for the entire corsage, and the effect is said to be splendid. Her beads are all clouded. Mrs. A. T. Stewart has a complete set in tortoise shell and amber. She has also a collection of odd pieces, one of which, about the size of the palm of the hand, contains a small fish. It cost Mr. Stewart \$4,200. The Empress of Russia has a tea service of amber, twelve cups and saucers, milk jug, and sugar bowl. There are some ladies who buy amber articles of me who can hardly contain themselves when they hear of it. They would like to drink tea out of amber amazingly. I don't know whether it would communicate a delicately delicious flavor to the tea. It might; but then the Czarina has the finest tea in the world, sent specially as a present by the Imperial family of China. A German professor told me that there were Roman emperors who drank their wine out of amber cups, and that it was customary in Rome to reduce amber to a powder and mix it with beverages. I should think it would taste pretty much the same as copal gum.

"Now let me show you some of our odd pieces." The young man produced a cabinet and pulled out a number of drawers. "I told you that the assorters put on one side, as inferior, pieces containing foreign substances. When these have been washed and cleaned and cut it is often found that the object is of such a nature as to make a piece very valuable indeed. For instance, here is a piece with a small lizard; here is another with a scorpion. And a merchant in Hamburg has a piece containing a leaf that looks like an olive leaf. It is not curled up, but is flattened out as perfectly as it would be in a herbarium. He asks for it thirty thousand marks, or \$7,500."

---

### The Relation of Barrel and Spring.

THE question which often appears on the surface of the daily experience of watchmakers is: "How to select a spring to a given barrel, in strength and length, that will develop the greatest energy over the longest period?" In the inquiry for the best practical answer to this question, certain data have to be accepted as a unit.

In every barrel, the space or annulus contained between the barrel-arbor and rim of the barrel is the path over which the action of the spring occurs, and within certain limits we have the option to dispose of strength and length of this action. If we represent the available space as a sum which is made up of two factors, viz.: strength and length of spring, then it is evident that this sum, again, represents the work of the spring, which will be a constant quantity and equal to the energy with the period of rotation.

The caliber of a watch sets the limit to the rim of the barrel, and on the other side we have a boundary in the barrel-arbor. It has become quite an orthodox practice to make the barrel-arbor one-third of the barrel, regardless of the conditions of the spring. Nevertheless, the data of this measure rests on the "bending moment" of the spring, for which the diameter of the barrel has become an approximate substitute.

It is evident that the surface of the barrel-arbor forms a mold for the curve of the inmost surface of the nearest coil, whose outer surface, again, becomes the mold for the next, and so on. By an immeasurable difference, the radii of the adjacent surface of two coils are equal, and therefore, likewise, their circumferences; hence the variation in the measure of the circumferences is not between one coil and the next, but between the inner and the outer surfaces of the same coil. This difference is the measure of compression of

the inner surface and of the elongation of the outer of each coil. It can be shown that the measure of this compression and elongation is proportionate to the ratio of the difference of the circumferences is always constant for the same barrel, however we may vary the spring; whereas, by increasing the strength, we diminish the number of coils, and inversely we increase them by applying a thinner spring. But half the quotient of the difference of circumferences by the number of coils, divided by the length of each coil, is the line of the angle of deflection, from which it follows that the thicker the spring the greater the angle of deflection, and that the contrary is true in a thinner spring.

This angle of deflection is synonymous with the principle of the "bending moment" of the spring, which, again, may be represented by a statical couple, whose moments are the pressure and tension of the opposite surfaces into the thickness of the spring. Hence, for equal bending moments, a thinner spring will admit of a much greater angle of deflection than a thicker one, and therefore will admit of a smaller barrel-arbor.

Since the number of turns or angle of rotation of a barrel has become almost uniform in all modern watches, and the strength of the mainspring has a definite relation to this measure and the size of the barrel, the latter has become the convenient unit for the bending moment of the spring, which is determined by the diameter of the barrel-arbor.

It is unfortunate that the conditions of bending moment clash with the angle of rotation of the barrel. If we increase the thickness or strength of the spring we require more space, or a larger path for the action of the spring, but the principal of bending moments not only will not admit this increase, but for the sake of the durability of the spring, demands a barrel-arbor of larger diameter, and therefore curtails the space, and hence the number of barrel rotations. The dimensions of the barrel-arbor are therefore controlled by two conditions. No stronger spring than such a one whose bending moment is satisfied by a barrel-arbor whose diameter is one-third of the barrel could be used so as to get sufficient turns; and, on the other hand, few watches will admit of a spring that will warrant a departure, as a rule, in the other direction; therefore, without any further proof, we will take the diameter of the barrel-arbor in the general caliber of watches as one-third of the barrel rim (inside measure).

The question becomes now one of area, or space occupied by each coil of the spring, and appears somewhat paradoxical. If the mainspring is wound onto a spring winder whose diameter corresponds with that of the barrel-arbor, the number of rotations of the winder will equal the coils gathered up, conditional that the coils on the spring are not concentric with the center of the winder. Thus it will hold good, if the spring is straight or gathered up from a bobbin, but not when the spring is held by the hand and concentric with the winder. It is this latter condition which is identical with the spring in the barrel. If we make a slot in the rim of the barrel and gather the spring onto the arbor through this slot, we should find that the barrel-arbor would turn once for every coil it collects, but when the spring is gathered on to the arbor from the coils collected within the barrel we obtain a different result, and thus, though in the first case the number of coils on the arbor would represent the number of turns the arbor had made in turning, in the latter this assumption would be altogether misleading.

That this is so can be easily verified. If a barrel is very full, the number of coils collected on the arbor when wound up are proportioned to the length of the spring, but the number of rotations that the barrel-arbor has made in collecting them has become less as the number of coils increased.

Again, if the spring is shortened, we increase the number of rotations of the barrel-arbor as we diminish the number of coils we gather up. This increase progresses to a certain point, beyond which the decrease in the number of coils and rotations progresses in a parallel instead of an inverse ratio. It is evident, then, that what-

ever spring we use, there is a definite point in its length where we obtain the maximum number of rotations. In a given barrel and spring we have three quantities that determine the number of rotations, viz.: the area of the space, the strength of spring and its length. Starting with the first as a unit, we shall endeavor to determine the second when the first and third are given, and the third when the first and second are given, which will be an answer to the question heading this paper.

#### PROPOSITION A.

*In a given barrel, the number of rotations of the arbor in winding the spring, or of the barrel during its development, is proportionate to the difference of the diametrical measures of the area's covert, when the spring is wound up, and when it is down.*

In reality the spring forms a spiral, hence no one coil represents a perfect circle. If, however, we take the distance from the center to any point between any two coils as radius then the two radii into 3.1416 will give the accurate measure of a coil. Now it is evident, that the number of rotations of the arbor in winding the spring is equal to the sum of the differences of the circumferences of the coils when down, and when gathered onto the arbor. This can be verified by experiment. If a spring is put into a barrel that almost fills it, the arbor will make very few turns in winding the spring. This is due to the fact that as the coils that are to be gathered up lay very close to the surface they are to cover, the difference of their circumferences must be very small; hence, though we get a larger mass on to the arbor, the number of turns that it makes in gathering them is really less than with a shorter spring.

There is another condition which becomes a factor in diminishing the turns with a full barrel. As coil after coil is collected onto the arbor, they become part and parcel of the arbor, and thus the radius of the last turn gathered is to the following one as the radius of the barrel-arbor to the first coil. But the angle of rotation of the arbor in gathering a single coil is proportionate to the difference mentioned divided by the radius; hence, as in equal arcs, the angles vary inversely as the radii, it follows that at each coil the arbor must move through a smaller angle than it did in the preceding one. We see, therefore, that the angular motion of the spring is in an inverse ratio to the coils gathered.

It follows, therefore, that as we shorten the spring and diminish the number of coils, we increase the angular motion of the arbor-barrel. This holds good up to a certain point only. Suppose we apply a spring so short that it occupies one or two turns only when down, then, though the difference between the circumferences when reposing against the rim of the barrel and when coiled up is at maximum, yet their sum must necessarily be small; hence it is apparent that there is a limit in this direction, and that the length of the spring is also a factor in the barrel rotations.

We have shown that in starting with a full barrel, by gradually shortening the spring, we increase the angular motion of the arbor; and that there is a point somewhere in its length and if we shorten it beyond that point the angular motion of the arbor will again diminish. Now, if we can show also that the angular motion of the arbor or barrel in winding or unwinding a long or a short spring is in ratio of the diametrical or radial measure of the areas covered by the spring in both conditions, we shall have proved the proposition.

The respective areas covered by the spring are annuluses, and are always equal in surface measure; hence, it follows that as the diameters of this annulus diminish, the difference in their diameters or radii must increase and that when they increase the reverse will be true.

But we have to show that the differences of the radial measure of the areas covered by the spring is in every respect similar to the sum of the circumferential differences of the coils, and that hence both are in the same ratio to the motion of the arbor or barrel.

It can be shown that this difference is least with a full spring or with a short one, and greatest at some intermediate point.

We have already stated that the space covered by the spring when wound up or when down, is always equal, and that its form is called an annulus.

The area of an annulus is found by multiplying the sums of its diameters by their difference, and this into 0.7854.

Suppose the radius of a barrel (inside measure) is = 1, the radial measure of the spring is = 0.333, then the space covered by the spring, when down, is an annulus whose outside radius is = 1, and inside radius = 0.666;

$$\text{Hence half its area} = (1 + 0.666) \times (1 - 0.666) \times 0.7854.$$

Let the radius of the barrel-arbor = 0.333, then when the spring is wound up this will represent its inside radius, and its outer will be x. Then

$$(x + 0.333) \cdot (x - 0.333) \times 0.7854 = (1 + 0.666) \cdot (1 - 0.666) \times 0.7854;$$

therefore,

$$\begin{aligned} x^2 - 0.333^2 &= 1 - 0.666^2 \\ x^2 &= 0.5564 + 0.333^2 \\ x &= \sqrt{.667289} \\ x &= .816 \end{aligned}$$

and the difference in the radial measure

$$\begin{aligned} &= (.816 - .333) - .333 \\ &= .483 - .333 \\ &= .15 \end{aligned}$$

Let the spring, when down, cover one-half the barrel, then when it is wound up, we have

$$(x + .333) \cdot (x - .333) \times .7854 = (1 + .5) \times (1 - .5) \times .7854$$

therefore,

$$\begin{aligned} x &= \sqrt{.860889} \\ &= .927 \end{aligned}$$

and difference

$$\begin{aligned} &= (.927 - .333) - .5 \\ &= .594 - .5 \\ &= .094 \end{aligned}$$

Again, let the area covered by the unwound spring equal  $\frac{1}{8}$ , or .1666, thus:

$$(x + .333) \times (x - .333) \cdot 7854 = 1 + .8334 \times (1 - .8334) \times .7854;$$

therefore,

$$\begin{aligned} x &= \sqrt{.416333} \\ &= .645 \end{aligned}$$

and difference

$$\begin{aligned} &= (.645 - .333) - .1666 \\ &= .312 - .1666 \\ &= .1454 \end{aligned}$$

Thus we see that in either extreme case the difference in the diameters is least, and it can be shown, that at no ratio will it be greater than when the spring occupies .25 to .26 of the space. But this difference, divided by the thickness of the spring, gives the number of the rotations of the barrel arbor, hence the proposition at the head of this paper is proved.

PROPOSITION B.

*In a given barrel the unit for length and strength of the mainspring is the diameter of the barrel space.*

In a barrel whose radius is = 1, and the radial measure of the area covered by the spring when it is unwound = .25, the radius of the outside turn when wound up,

$$\begin{aligned} &= \sqrt{1 - .75^2 \times 333^2} \\ &= \sqrt{.547389} \\ &= .739 \end{aligned}$$

and as the variation in the radius would not change the ratio, it follows that for a barrel, whose diameter = 1, and therefore radius of space =  $\frac{1}{2}$ , the radius of the outer coil when wound up

$$\begin{aligned} &= .333 \\ &= .3695 \end{aligned}$$

Then the radial measure of the annulus, or area of the coils of the spring, which represents the rotation of the barrel or barrel-arbor

$$\begin{aligned} &= .3695 - (.333 + .25^2) \\ &= .3695 - .2915 \\ &= .078 \end{aligned}$$

It has to be remembered that this space represents an extra coil. Thus starting from the hook on the barrel-arbor, it will be noticed that when one coil is gathered up, the radial measure is equal to two coils, hence in any spiral the number of thicknesses is always one more than the number of coils. Hence if we require five rotations of the barrel or arbor, then it is evident that the measure of the thickness of six coils = .078 of the barrel unity, and therefore the thickness or strength of one coil

$$\begin{aligned} &= \frac{.078}{6} \\ &= .013 \end{aligned}$$

To find the length of a spring of this strength that shall make the given number of rotations, we have to proceed thus:

The radial measure of the annulus, covered by the whole spring, when wound up, is

$$\begin{aligned} &= .3695 - .333^2 \\ &= .203 \end{aligned}$$

Since .013 is the measure of the thickness of one coil, the number of coils represented by .203

$$\begin{aligned} &= \frac{.203}{.013} \\ &= 15\frac{1}{2} - 1 = 14\frac{1}{2} \end{aligned}$$

Therefore the length of the spring is obtained by multiplying the mean diameter of the annulus into the number of coils, and this into 3.1416.

$$\begin{aligned} &= 2 \times (.203 - .013) + .013 + \frac{.333}{4} \times 3.1416 \times 14.5 \\ &= 2 \times .19425 \times 3.1416 \times 14.5 \\ &= 17.6974 \end{aligned}$$

The mean diameter being increased by two thicknesses of spring becoming part and parcel of the barrel-arbor. Thus in a barrel whose inside diameter is = 1 inch, and if we use a spring whose thickness = .013 of an inch, and length = 17.6974, we obtain five turns of the barrel-arbor in winding the spring.

Now it is evident that if we vary the thickness of spring in the same ratio of the diameter of the barrel, we retain the same number of rotations of the barrel. Again, since the number of coils would remain constant, the only factor in the length which varies, is the mean diameter of the area covered by the spring, and this evidently varies in the same ratio as the diameter of the barrel, and, therefore, the length must also vary in the same ratio; hence the diameter of the barrel is the unit for length and strength to a given number of rotations of the barrel.

From this it follows that on the basis of the foregoing formulas tables can be constructed to barrel unity, giving length and number of turns when strength is known, and giving strength and length when the number of turns is given.—[J. HERMANN.

The Decoration of Clocks.

IF THE giving of such and such forms to the clocks which take a place in our dwellings is not a matter of indifference, and if good taste demands that their mounting should be varied to harmonize with the rooms in which they are to be placed, or to suit the taste of the person who has to use them, it is not less necessary to pay the same attention, to bestow the same delicate foresight on the construction of those monumental clocks which ornament the exteriors of public buildings. These have a value and a rôle so perfectly determined, they have in some way a social function so characteristic that it is very evident that architects have no right not to take into consideration how to make them suit the purpose for which they were intended. These clocks, in fact, dependent on the monument of

which they form a part, according to the town or the quarter where they sound the hour regularly, have they not a differing importance? Are they not charged, amid the feverish activity which carries away the inhabitants of a city, with regulating the course of the day's work, with indicating for each one his duty, the moment for business, and the moment for repose? Addressing themselves thus indiscriminately to everybody, rendering a service to everyone, especially in our modern cities where the value of time is so much insisted on, does it not follow that it is indispensable to well consider the situation which is best adapted to them, the form which they ought to affect, the architectural arrangement which shall be proper to one and not to others, so that they shall be plainly visible, and their decoration in accord with those general ideas which they are destined to evoke?

The Middle Ages and Renaissance understood so perfectly the function of public clocks that almost all those which were made during those epochs testify to the different preoccupations of those who constructed them. In the twelfth century, when striking clocks began to appear, there was introduced in their decoration a remarkable degree of fantasy, which was yet always logical. In the fourteenth century there were scarcely any cities in Italy, Germany or France where was not seen, either on a public house or on a church, a clock, a veritable *chef-d'œuvre*, which indicated clearly, by its happy forms and the vast dimensions of the dial, often decorated with painting, and by the pleasing ingenuity of the mechanism of the striking parts, the formal intention which had presided over its establishment. Each inhabitant could, from a distance, distinctly tell the hour.

The clock, provided with a complicated peal of bells which sent out its joyous chimes even to the depths of the most dingy dwellings, had its own personality, its own peculiar character, in which were incorporated and incarnated all the diversities of local character. The proverb to-day so much in vogue, which speaks of the love which one has for his clock-tower, does it not come from this, that this venerated clock-tower, ornamented with its ancient clock, records the sorrows and the joys of every hour of life?

Everybody has seen or heard of the celebrated clocks of the cathedrals at Lyons, Strasburg, Caen, Lille, Metz, Auxerre, Sens, Dijon, etc., which were embellished with puppets (*jacquemarts*) which struck the hour with hammers.

That at Strasburg is composed of

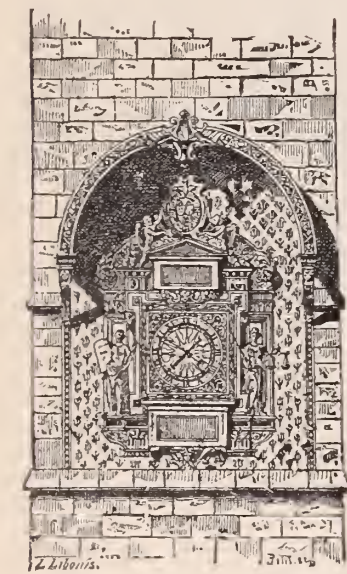

CLOCK ON PALAIS DE JUSTICE,  
PARIS.

a large wooden disc, on which were painted indications of the principal movable feasts. In the middle is a dial whose hands mark the movement of the sun, the moon, the hours and their subdivisions. It is crowned by a statuette of the Virgin, before which at noon come to prostrate themselves the Magi; a cock crows at the same time and flaps his wings, and a little peal of bells plays tunes at certain hours.

At Berne, in Switzerland, can be seen a clock whose movement is yet more peculiar. At each hour a cock crows, and a clown strikes with two hammers upon two bells, while a personage seated on a throne turns his head, opens his mouth, and with one hand waves a sceptre, and with the other an hour-glass as many times as the hammers strike. Before this king defile bears in every kind of position and costume.

At Lunden, Switzerland, there used to be a clock so artistically arranged that when the hour struck two knights encountered each other, and exchanged as many blows as there were hours to strike. Then a door opened, and at the back appeared a theatre, where the

Virgin Mary, seated on a throne and holding the infant Jesus in her arms, received the visit of the Magi, followed by a cavalcade. The kings prostrated themselves and offered their presents, two trumpets sounding during the ceremony, then the spectacle closed abruptly, and recommenced an hour afterward. We give here a fac-simile of a design composed by Nicolo dell' Abate for the sculptural decoration of the clock on the public palace at Bologna. The principal

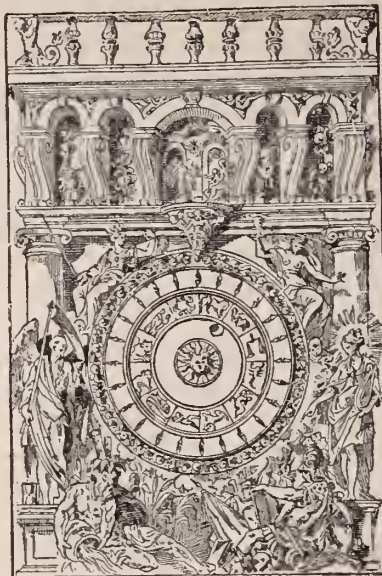

CLOCK AT BOLOGNA, DESIGNED BY  
NICOLO DELL' ABATE.

panel, included between two Ionic columns, shows the zodiac, surrounded by six allegorical figures—above, Justice and Faith, below them Apollo and Saturn standing, and below two reclining Rivers, doubtless the Reno and Felsina (Bologna). Behind the rivers are to be seen the two characteristic towers of Bologna, l'Asinelli and la Garisenda, and near the figure Felsina a shield bearing the device "*Liber-tas*." We could cite many other examples of such Italian clocks as perfectly equipped and as sumptuously constructed.

At Paris the monumental clock on the Palace of Justice, whose construction dates back to Charles V., and which, under Charles IX. and Henry III., was refurbished, repainted and frescoed, and then ornamented with figures by Germain Pilon, and restored by M. Duc in our own time, is one of the most ancient and most remarkable public clocks in France. Our architects may still seek inspiration from it as a model, excellent for its simplicity and the frankness of its conception, the harmony of its lines and its just proportions. Unfortunately, we have lost the *naïveté* of our forbears, and we can no longer recover their luminosity of invention, nor their love for the logical in the search of elegance. The new clock of the Hôtel de Ville, Paris, it must be allowed, has been treated by the eminent architect of this fine work with quite a special care. We willingly give him credit, for he has well understood the place which in buildings of this sort should be occupied by the instrument charged with



CLOCK, HOTEL DE VILLE, PARIS.

regulating the time, and indicating to the great masses the hours which go by. Situated in the middle of the façade, this clock forms in a certain sense in this vast monument a little building by itself, with its pediments, entablature, pilasters, its sub-basement harmonizing strictly with the general lines, and detaching its fine, rich *silhouette*, without disturbing the unity of the whole. At right and left of the dial, arranged in the break of the lower pediment, are two

standing statues, surrounded by infants and divers attributes. These represent Commerce and Industry. Then above, reclining on the consoles, are two figures seemingly personifying the Seine and Marne. Above the dial, in a panel between two pilasters, is the City of Paris, with proud and haughty mien, but who seems ill at ease in the position, for she seems imprisoned in her frame of stone. At the top of all is a triangular pediment, in the midst of which is the coat-of-arms of the city of Paris, surmounted at each side by two female figures, Vigilance and Prudence. It is the most finished morsel in the whole work, is delicate in execution, and elegant and pure in design, conceived in the sentiment of the Renaissance, and carried out with the delicacy of jewel-work. It is the work of a very able sculptor, M. Charles Gauthier, professor at the Ecole des Arts Décoratifs, and the author of several remarkable works; but there is a shadow over this picture, and it is here that presents itself the problem which we indicated at the outset. In the midst of these eleven figures magnificently mounted, in this monumental clock, what becomes of the dial, the principal motive about which all the rest should be but accessories? Alas, it disappears humbly and effaces itself before this richness, and it was with difficulty that one could from the ground see the hands, before the architect, in order to remedy this deplorable defect which he only detected after the work was done, attempted to increase their proportions, so that the mind was inevitably seized by the following dilemma: Either the architect had no intention of establishing there a clock, and therefore this minute dial is only an incomprehensible and useless ornament—a very rebus laid before the eyes of the passers; or, really intending to construct a clock, he has confounded the accessories with the principal, and has committed an unpardonable solecism by crushing the latter under the luxuriousness of the former.

Such is the criticism which has appeared to us worth making. It has already been made in the journal "*De l'Horlogerie*," by a clock-maker, who is likewise an artist, M. Gustav Sandos, whose judgment we find in perfect accord with ours.

To the foregoing criticisms he adds the following reflections, which may be held as excellent advice: "In our epoch," says he, "remarkable efforts are made to attenuate the coldness of stone by employing in construction marble, bronze and faience. It was a unique opportunity to introduce in the central portion a polychromatic decoration, which has been evidently sought by placing men-at-arms sparkling with gold upon the roof. This employment of color would certainly have been there more in place, and would have agreeably drawn the eye by breaking the monotony of the façade."

Surely those grave persons who to-day smile over the antique clocks with their chimes and puppets, whose mythical apparition rejoiced the hearts of our ancestors, cannot find fault that an attempt is made to enliven so monotonous an object as a dial. Art and science have not yet declared war, I imagine, and it is not forbidden to bestow a little grace and harmonious equilibrium upon our public clocks under pretext that these pretend to go with precision.—[VICTOR CHAMPIER in the *Revue des Arts Décoratifs*.

### The Regulating of Watches.

[By HERMANN GROSCH, in his *Praktisches Handbuch für Uhrmacher*.]

INTRODUCTION.—Although the subject of regulating watches will be considered by many as pretty well exhausted, in view of the great number of works existing on horology, and more especially the excellent work of Mr. C. Saunier, still I do not think that a simple article, written with the view of being understood by every reader, and containing the experience of many years, will fill the already full measure to overflowing. I am forced to confess, on the contrary, that this subject has always appeared to me as not being treated with due consideration; good regulators were very scarce years ago; there were a few at Geneva who made a great mystery of their art and taught

no apprentices; it was not much better in Paris; London possessed several good regulators, although, if we were to believe the statements of Mr. Glasgow, the very reverse was the fact. We record with great satisfaction that German watches, especially those of Mr. Lange, of Glashütte, show a closeness of regulating, which, as far as anchor watches are concerned, stands unexcelled.\* Total differences of only two seconds within four weeks, according to the certificates from the Leipzig Observatory are next to nothing, especially when we consider the severe tests to which watches are subjected at such places.

What constitutes the actual value of a watch in the eye of its possessor? The answer is simple: Its good rate; that the watch preserves its rate not alone in the different positions, but also in the different temperatures. Present your friend with a fine watch that has not been well regulated, and he will simply pronounce it to be of an inferior grade. Frequently, very severe remarks about watch-makers are made even by persons who ought to know better; who bought a fine grade watch which was not very closely regulated, and they were disappointed in its timekeeping qualities. That much of this disappointment is due to a wrong treatment at their hands is beyond question, but, after all, it is only too true that many watch-makers are perfectly in the dark on the subject of regulating watches, and a great service to horology would be rendered if some one were to teach an art of regulating, based upon substantial foundations and performed with convenient means. By "convenient means" we understand those by the use of which a continued correctness of rate is produced without the disagreeable necessity of taking down various parts, and continually disturbing the performance of the watch.

What are these means, and upon what principles are they based? Mr. M. Phillips, in his treatise on the balance spring, confirmed by his most ingenious reasonings the suppositions of Berthoud, the discovery of Breguet's over-coil spring and the observations of Moinet, etc., and arrived by power of his reasoning to the following results, which were heretofore merely suspected by former regulators and which have been fully confirmed by practice, to wit:

Isochronism, or the equal duration of the larger and smaller balance vibrations, can be established by the following conditions:

1. The center of gravity of the whole balance spring must be upon the balance staff.
2. The single coils of the balance spring must also during its activity, in other words, during the vibrations of the balance, be concentric to the center of the balance staff.
3. The balance pivots must, during the expansion of the spring, exert no pressure upon the sides of the hole.

These conditions are best complied with by a cylindrical spring, next by an over-coil or Breguet spring, and under certain conditions by a flat.

We will in the following article confine ourselves chiefly to the Breguet or over-coil spring; and we shall principally devote our attention to the regulating of finer grade watches, that is, those with compensated balance and over-coil spring, and finally add a few remarks on the regulating of inferior grade anchor and cylinder watches. [The author next speaks in terms of high encomium of the prize essay by Mr. Immisch: "Isochronism of the Balance Spring," although he urges several objections to different statements, as follows]:

We would say, however, that we do not unconditionally subscribe to everything recommended by the author; according to our experience we do not agree with him when he proposes the flattening, or worse yet, the grinding oblique of the pivot ends; regulating in hanging and lying is, after all, nothing else than the reduction to isochronism of the smaller and larger vibrations in these two different positions. When regulating in the vertical position many difficulties

\* The translator would state that this article was written *before* the sweeping triumphs of the AMERICAN WATCH, and he therefore translated these ebullitions of self-vanity together with the article.

are to be overcome in consequence of the pivot frictions; the vibrations are smaller and of greater duration while in a horizontal position, when the friction of the pivots is diminished larger vibrations, but of a shorter duration, occur. This is the most important and at the same time the most difficult point in regulating; according to our view, every friction is to be reduced as much as possible. By reason of the thickening of the oil, which unhappily takes place far too soon, the frictions are increased anyhow, and we therefore would recommend slightly rounded-off pivots, well polished, with edges well rounded-off, so that they do not scratch the finger nail; the best form is the conical, although the part moving in the jewel hole must be perfectly cylindrical, pass through the jewel hole, its end run against the cap jewel, and, in general, be not too thick, while at the same time not so weak that their breakage is to be feared at every concussion; the jewel holes must be of an olive shape and well polished, fit well to the pivots, at the same time permitting them due shake so that the balance vibrates as freely as possible.

As we chiefly write for the young beginner we would recommend that he first satisfy himself whether there are no defects that will render a regulating impossible; all the functions of the escapement must be in thorough working order; a defect, trifling in itself, may jeopardize the entire final result. One defect, which is generally found only in good watches, and consequently is often overlooked, consists in too great an exactness of the different parts of the escapement. The drop is frequently unequal or so scant that in certain cases it already suffices to remove the gilding from those places of the plate against which the fork, during its rests, applied itself, in order to correct it. So as to be very certain, let him pass through each single tooth of the wheel, by detaining the fork in this process with a pointed pegwood, and conducting it to both sides up to detent.

Satisfy yourself that all jewel holes are set straight, that no pinchings occur, and that all the holes of the center wheel are in order, as they are frequently neglected. The wheel must have sufficient shake, nor must the holes be too contracted, otherwise the oil will draw away from the pivots, after which they commence to wear each other and the rate of the watch suffers. It is barely worth mentioning that the depths must be inspected, also the barrel stop work and the development of the spring. It must be duly taken into account that every want of attention, every neglect, will eventually avenge itself; time is wasted uselessly, and the regulator retrogresses instead of progresses; unhappily, there are too many watches which are constitutionally very rebellious and inclined to backslidings.

Also satisfy yourself that the balance pivots are round; we have often found them oval on conical pivots. It is difficult to detect this defect, which produces the same effect as a balance out of poise, that is, it is absolutely impossible to establish an isochronism with them; there is no other remedy than to make a new staff, which, of course, is to be well hardened.

There are certain errors more readily detected by the ear than by the touch and sight; for this purpose wind the watch partially and listen, placing it in all possible positions. To these belongs a slight scraping of the ruby pin in the notch of the fork or on the guard pin, or on the prongs of the fork, the scraping of the balance spring or its bad developments, etc.

The balance, especially, demands all our attention; it must run perfectly straight and true, and be poised faultlessly exact. It will have happened to many a regulator that a watch which he regulated with great exactness, and the balance of which was truly round, was returned to him after a certain time because it no longer would keep correct time and could not be regulated, without any visible cause to produce it. When closely examined it was found that the balance had drawn out of true, in consequence of which the regulating had been destroyed. This may be owing to an imperfect and faulty homogeneity of the metals of the balance. To prevent another occurrence of this kind, heat the balance upon a flat metallic plate to about 70 degrees, let it cool, and then cautiously round it between the fingers; heat it again and continue the manipulation until a fur-

ther alteration will no longer occur, and you are certain that it will resume its exact round shape.

When on a hot summer day it becomes necessary to handle a balance repeatedly, which is necessary when turning a new staff, regulating the compensation or other work of the same nature, it is advisable to occasionally cool it off upon a cold metal plate; without this precaution it may happen that the balance rim will contract so that it alters its diameter in mean or low temperature, in consequence of which the regulating is disordered.

The size of the barrel cover has generally been accepted as indicative of the diameter of the balance, and half the breadth of the mainspring as the height of its rim. This rim is provided with from 12 to 16 gold screws. We must at this opportunity again highly recommend the balances of..... A highly original device and conscientious execution prevent the above mentioned two defects.. .. Beside this they are provided with fine slits for the regulating screws; as is well known a balance contains two or four screws for the sole purpose of shifting the center of vibration or gravity to a small degree, by being screwed in or out after the watch has been regulated with the balance spring, by means of which the last exact regulating is produced; where these screws are located in said balances, a longitudinal split has been made with a very thin fraise in the center of the balance rim, so that a springing screw hole is obtained. We have never, in the many years that we were engaged in regulating with these balances found a single instance confirming the objection that the regulating screws are prone to fall out, although we found this repeatedly in balances of English and Swiss manufacture.

If a watch advances in heat, it will be necessary to remove the screws or the balls upon the balance rim more toward the arms or the closed part of the rim. If a satisfactory compensation is not obtained thereby, cut or file a trifle from the rim at the place of the cut, make this wider and replace the wanting weight by two small screws placed opposite to each other.

(To be Continued.)

---



---

## Proceedings of the Horological Club.

---

### A DISTINGUISHED BODY OF WATCH AND CLOCK MAKERS.

*One hundred and twenty-fourth discussion.—Communicated by the Secretary.*

[NOTICE.—Correspondents should write all letters intended for the Club separate from any other business matters, and headed "Secretary of the Horological Club." Direct the envelope to D. H. Hopkinson, Esq. Write only on one side of the paper, state the points briefly, mail as early as possible, as it must be received here not later than the eighth day of the month, in order to be discussed and reported in the CIRCULAR for the next month.

---

### NEW ARITHMETICS AND NEW KINDS OF WEIGHTS.

#### *Secretary of Horological Club:*

By answering the following questions you will greatly oblige a young subscriber:

I have an arithmetic which says: 20 mites=1 grain; 20 grs.=1 pwt.; 20 pwts.=1 oz.; 12 ozs.=1 lb. Is it correct? If not, please give the correct table. The same book says: "The term karat is also applied to a weight of 3½ grs. Troy, used in weighing diamonds; it is divided into 4 parts called *grains*; 4 grs. Troy are thus equal to 5 grs. diamond weight." Is it right?

I have obtained a few numbers of THE CIRCULAR of 1882, and seen the Patent Report, which I think very interesting and instructive. Why is it not published now?

Can back numbers of THE CIRCULAR be obtained at the office?

J. B. S.

Mr. Clerkenwell thought he knew something about arithmetic, but he must acknowledge his ignorance of the "mite" as a weight. As to the table being correct, our correspondent did not state what was the system or name of the table. It evidently is not Troy, nor



Apothecary's, nor Avoirdupois, which comprise all the usual weights. There may be such a system in use somewhere, for some purpose, but he did not know of any such, and would like to know what the book called it; also the name of the book and how old it was.

As regards the statement about the diamond weights, a short calculation would show its incorrectness. If the karat is  $3\frac{1}{2}$  grains Troy, then 1 grain diamond weight would be one-fourth of that, or  $\frac{7}{8}$  of a grain Troy. On the other hand, if 4 grains Troy are equal to 5 grains diamond weight, then one grain diamond weight would be  $\frac{4}{5}$  of a Troy grain. There is quite a difference between  $\frac{7}{8}$  and  $\frac{4}{5}$ , according to common arithmetics, but perhaps this one can get around that by some new arithmetical discovery. By all means give us the name, etc. We live to learn, and if it is possible to convert  $\frac{7}{8}$  into  $\frac{4}{5}$ , we can extend it a little further and make 1 equal to 2, and so keep on stretching it out until we can convert *tuum* into *meum* and make our everlasting fortunes by it.

The back numbers of THE CIRCULAR, he believed, were exhausted up to quite a recent date, but odd numbers could probably be supplied for several years back. That could only be ascertained by naming the numbers wanted at the office.

#### WATCH REPAIRING—"TRAIN TESTER."

*Secretary of Horological Club:*

Your honorable body has favored me with some numbers of *The Metallurgist*, for which please accept my thanks until you are better paid. As your paper is the medium of correspondents who wish to contribute to the interest of our watchmakers at large, I take this opportunity to say that I have worked all my life at the watchmaker's business, and have felt that there was a great difficulty in discovering difficulties of watches that have worn themselves into a constitutional ailment, and the same with some of our cheap made new American watches. To illustrate: a workman must take a watch to pieces, look it all over and see what is to be seen, and clean and repair all that he can find wanting to be done to make the watch run. He then puts it up and still it fails to run. Again he takes it to pieces and looks more closely, then puts it up again to be disappointed. He then takes it down and tries the pivots and deepthing of all the wheels, puts up the job again; perhaps it may run and perhaps it won't turn a wheel. Now, I have invented a little device that I have used, which is of great worth to our trade. After I clean and repair a watch, I attach what I call a train tester that I attach to the movement, and it allows the watch to run the second wheel around once in 4 seconds, giving me the opportunity of seeing the train run in all its perfection; or, if it is imperfect, it will not operate the train tester, so that I am able to learn in two minutes what it will take two days to find out without this little device. Every watchmaker should have one, and I have shown it to two of our best workmen here; they think it is of great value to our trade. I think that there is money in it, to myself and all parties that are interested in laying it before the trade. When once seen it will be appreciated. I have not patented it yet but have taken steps to secure my rights, and I now wish to have some active party to become half owner with myself. Terms can be learned on application by letter. I will here state a case in which I have had the benefit of my invention, the train tester. A man brought in an Elgin watch, said he had carried for 20 years; it had always proved a faithful servant but now had stopped. I applied the train tester; it would not move. I took it to pieces, cleaned it, put it up. It would run a minute or so then stop. I attached the train tester; it would not move. I took it apart again and looked it all over, was about to put it up again for trial, when I noticed a faint mark on the end of the cogs of the barrel wheel. On examination I found that the 20 year winding had worn the barrel so that it inclined over toward the plate pillar, and rubbed against a little bead that was turned on the pillar for ornament, taking from the train the power due it from the mainspring. I filed off the little bead and put the watch together, attached the train tester; it works fine. I then completed the watch in case and it works well. I have written to B. F. Norris, of Chicago, offering to subject it to an investigating committee, if I can find the party that wishes to take out the patent complete, and complete the manufacturing of the device and lay it before the consumer. You are at liberty to publish this if you deem it of any interest to our trade. Address Box 478, San Diego, California.

J. H. TIBBITS, Watchmaker.

Mr. O'Lever said the device appeared to be something for moving the wheels without putting the watch all together. No doubt it

would be useful in many cases, and we publish Mr. Tibbit's letter in order to give him an opportunity to find a party to take hold of it.

But as for repeatedly taking a watch down and putting it up again before finding the trouble, that is something that a skillful workman seldom does—indeed, a good workman feels ashamed to have to take a watch apart even the second time, for he considers it a reflection upon his skill in examining watches for defects. In the case stated, a workman knowing that the watch had run twenty years should always expect to find the barrel worn and inclining more or less, and should give special attention to that part in the examination. As a rule, a good workman who examines a movement carefully and thoroughly, should be able to discover its faults the first time. There is, of course, a system or order in which the parts should be examined to economize time and labor, and all workmen would do well to study the remarkably full and valuable directions for examining the different kinds of watches given by "Excelsior" in his "Practical Hints on Watch Repairing," published in THE CIRCULAR a few years ago. Any one who follows them properly will seldom have to repeat the examination, but may feel confident that he can put the watch up and have it "stay fixed."

#### REMOVING SOFT SOLDER—OILING LEVER PALLETS.

*Secretary of Horological Club:*

What is there that will remove soft solder from cases, breast pins, etc., preparatory to hard soldering, and that will not interfere to any extent with the gold or silver, as you are probably aware of difficulty experienced with such articles that have been in the hands of some "botch," the Lord only knows of the thousands too many of such we have in "the land of the free." Would you advise not oiling pallets or scape teeth of lever watches. I customarily oil them slightly; had a P. S. B. as I believe in good order but which did not make a first-class motion as I thought, until I applied a trifle of oil to scapement.

S. R. T.

Mr. McFuzee replied that a method was published in our Proceedings a couple of years ago for removing solder by a chemical solution which dissolved the solder without affecting gold and silver. He did not remember the formula, but it was simple and cheap. Owing to recent business changes, moving, etc., our files of THE CIRCULAR are not accessible, and we cannot refer to them for the details. But very likely Mr. T. had the back numbers and could readily refer to them.

As for oiling the pallets of detached levers, it depends somewhat on circumstances. Very fine movements are supposed to be so highly finished as not to need oil there, which is held to be detrimental to fine timekeeping; but the more usual practice, especially with ordinary watches, is to oil them. They should not be smeared with oil so as to run up on the under side of the lever fork, or on the top of the escape wheel, as it will gather dirt and lead to sticking and clogging the wheel while passing near or under the fork. Only the pallet stones should be oiled and sparingly.

#### POLISHING STEEL.

*Secretary of Horological Club:*

Will you please tell me how to get a bright polish on steel, such as highly polished steel parts of watches? And what kind of steel should be employed, and where can it be bought?

At what speed should the polishing lathe be run for such work? By answering the above questions in THE CIRCULAR you will greatly oblige me.

B.

Mr. Uhrmacher said that the polish did not depend on the kind of steel used. Any good, close-grained steel would do. It should be properly hardened and tempered, and (after being brought as nearly as possible to its final shape by turning or otherwise), then ground with oilstone dust and oil till a fine gray surface is obtained. The polish is then put on with crocus and diamantine. Different kinds of "laps" are used by different workmen, the most common being soft iron, copper, tin, type metal and bell metal. The latter is generally preferred for small laps on account of its hardness, keeping its shape well. But type metal is also a very good material. Large type can be bought at any printing office very cheaply, after

being worn too much for printing from, and filed into shape. Bell metal slips can be obtained from any material dealer. The speed of the lathe should be quite rapid for polishing. But the chief requisite for obtaining a good polish is to have the surfaces truly plane or flat. An irregular surface can never have a perfect polish. All the corners should be cut clean and square, and the flats must extend to the very edges—if edges are rounded off it shows poor workmanship.

#### ISOCHRONAL HAIR SPRINGS.

##### *Secretary of Horological Club:*

Is there no hair spring that will not have to go through such a long process before it will be isochronal? It seems as if there might be something invented which would not require so much labor—something that would be isochronal naturally. Why not? I see that "Excelsior" has got up a new kind of spring. Is that naturally isochronal? How is it made? Has he introduced it into use yet? If he has I would like to know where I could get one to examine. By answering the above you will very much oblige an old subscriber.  
W. H.

Mr. Regulator replied there is no such spring now used, nor has any ever been made known unless "Excelsior's" new spring is of that kind, and his circular seemed to imply that it was. Nobody knows how it is made, as he says that he shall keep it secret until he finds some manufacturer who wants to buy such a spring. He evidently thinks that the best way to keep a secret is to keep it in his own head—in which he is probably not far out of the way. It will be a pity, though, if none of our makers should have enterprise and trade pride enough to secure and introduce it, for such a spring would inaugurate a new era in watchmaking. Only imagine even the cheapest watches having isochronal hair springs! Lever clocks fitted with them would be as good timekeepers as pendulum clocks, and would probably soon supersede them. It is to be hoped that he has found a purchaser, and that the springs are now being made and applied to use.

All springs thus far known require to be tested and adjusted till they are brought into such size, form and length, that their strength will increase and decrease in proper proportion as the balance vibrates and the coils open and close. They are then called isochronized or isochronal. That is what occupies so much time. It is a long and tedious process at the best, although it may be considerably shortened by following some system. The different methods of isochronizing are fully described in "Excelsior's" book, the "Practical Treatise on the Balance Spring," and a careful study of them until the reasons are fully understood will enable the adjuster to work intelligently and easily, and to perform the adjustment closely and with certainty. Even after springs have been properly adjusted, any change in their length, either by taking up or letting out, injures or destroys their isochronism.

But there does not appear to be any reason why a spring might not be devised which would have that property naturally, and which would not be affected by altering the length—if we only had "gumption" enough to do it. When somebody does find such a spring, it will very likely be so simple and easy that we shall all wonder why *we* could not have thought of that ourselves, and will want to kick ourselves for being so blank blank stupid as not to see it.

---

#### Our Providence Letter.

[FROM OUR SPECIAL CORRESPONDENT.]

THERE IS no improvement in trade, and the outlook continues gloomy. The general impression seems to be that there will be but little business done until after the New Year. The recent failures of S. Friedman & Co., of Chicago, and E. Dahlheimer, of Cincinnati, have caused much unfavorable comment, and are of a

nature that should serve as a warning to the trade. In the latter case the circumstances were of a peculiarly aggravated nature. Dahlheimer spent about a fortnight in this city and Attleboro during the month of July last, visited quite a number of houses, made extensive selections of goods, and in almost every case volunteered a full showing of his affairs. His apparent candor in this respect in several instances gained the confidence of parties who had no former dealings with him, and despite the cautions they received from the mercantile agency they shipped their goods. Dahlheimer seemed to possess a peculiar influence over those with whom he came in contact as the following incident will show. One of our manufacturers, a sharp, shrewd business man, called on him the day prior to his failure, and told him that he had been told he was in some financial trouble. Dahlheimer indignantly denied this, produced his books for his inspection, and his creditor left him fully believing him to be a much maligned man, and from the examination he made of the books was satisfied that he was in easy circumstances and worth from \$30,000 to \$35,000 over all liabilities. You may judge his surprise when he heard of his assignment on the following day. The local papers have had lengthy notices of this failure, and an indignation meeting of creditors was held at the office of Mr. Chas. S. Pine on the 8th ult. A general meeting of the trade to consider the subject of how to prevent failures of this class is announced to be held at the rooms of the New England Manufacturing Jewelers' Association on the 18th inst. It is hoped that an association may be formed that will eventually drive out of the trade all persons whose transactions are of a questionable nature. It is a duty the manufacturers owe to the honest dealer, and they seem fully determined to carry it through.

The monthly meeting of the New England Manufacturing Jewelers' Association was held at their rooms on the 4th inst., the President in the chair. The minutes of the previous meeting were read by the Secretary and approved. The Treasurer then read his statement, which was approved and put on file. An application from a social club was read for the use of the rooms of the Association for one night. Some discussion arose as to the desirability of such an innovation, and it was finally resolved to decline the proposal. Mr. McCloy spoke very feelingly of the death of Mr. Peck, an old and respected member of the Association, and it was moved and unanimously resolved that a floral tribute should be sent his family. It was also resolved that the Association should, in each case of the death of a member, send a like tribute of respect. The meeting then adjourned.

Messrs. Ellison & Vester are bringing out an entirely novel line of goods. I have seen some specimens, and I think they will command a large and ready sale.

The firm of A. Holt & Co., platers and manufacturing jewelers, have dissolved, Mr. Joseph Weaver selling out his interest to Mr. S. Field. The business will continue under the same style. Mr. Weaver is about to move to Attleboro, where he will make a line of plated chain. His friends here (and they are many), cordially wish him success in his undertaking.

At the meeting alluded to above, it is probable that the subject of forming a Jewelers' Board of Trade will be ventilated. The trade feels the pressure of the dull times, and seems convinced that some united action is necessary in their own interest.

I heard a good story of one of our manufacturers here the other day, who bears the reputation of being a persistent practical joker. It appears that he had had a number of pigs attacked with "staggers," and a neighbor of his being in similar trouble appealed to him as follows: "Say, B., what did you give your pigs when they had the staggers?" "Rum and rock salt," was the reply. "How much did you give them?" "Why as much as they would drink." Away went the neighbor to try the remedy. The following day he put in an appearance at B.'s office with a very elongated visage. "Didn't you tell me you gave your pigs rum and rock salt?" said he. "Yes,"

said B., "I did." "Well, I gave it to mine and they are all dead." "So are mine," said B. triumphantly. I have not heard that B has been asked for any further medical advice in the case of sick pigs. Providence, Oct. 14, 1884. ASMODEUS.

net, Zanesville, Ohio; W. E. Walton, Richmond, Mich.; C. Guerre, New Orleans, La.; F. A. Herbert, Garnett, Kansas; S. D. Cook, Denver, Col.; O. Winterhalter, Henderson, Texas; H. W. Wyman, Las Vegas, New Mexico; L. Strauss, Socono, New Mexico.

### The Jewelers' Security Alliance.

President, DAVID C. DODD, JR.

Vice-President, AUGUSTUS K. SLOAN.....Of Carter, Sloan & Co.  
Treasurer, W. C. KIMBALL.....Of H. F. Barrows & Co.  
Secretary, C. C. Champenois.....Of Champenois & Co.

#### EXECUTIVE COMMITTEE.

C. G. ALFORD, Chairman.....Of C. G. Alford & Co.  
C. B. BISHOP.....Of Carrow, Bishop & Co.  
HENRY HAYES.....Of Wheeler, Parsons & Hayes.  
J. B. BOWDEN.....Of J. B. Bowden & Co.  
DAVID UNTERMAYER.....Of Keller & Untermeyer.  
E. F. DORRANCE.....Of Dorrance & Brother.

P. O. Box 3277.

Room 2, 170 Broadway, New York.

HON. ALGERNON S. SULLIVAN, Counsel.

A SPECIAL MEETING of the Executive Committee was held at the office of the Alliance on the 15th inst., at which the following applicants were admitted to membership, namely:

Calvin Du Bois, Walton, N. Y.; D. C. Dusenbury, Middletown, N. Y.; J. H. Hutchinson, Portsmouth, N. H.; Geo. Howe & Co., Lynn, Mass.; David Prager, Fort Scott, Kansas; Geo. H. Wood, Lowell, Mass.

### The Jewelers' League.

President, GILBERT T. WOGLOM.....Of Woglom & Miller.  
First Vice-President, WM. C. KIMBALL.....Of H. F. Barrows & Co.  
Second Vice-President, AUG. KURTZEBORN.....Of L. Bauman Jewelry Co. St. Louis, Mo.  
Third Vice-President, JAMES P. SNOW.....Of G. & S. Owen & Co.  
Fourth Vice-President, HENRY HAYES.....Of Wheeler, Parsons & Hayes.  
Secretary and Treasurer, WILLIAM L. SEXTON.....Of Sexton & Cole.

#### EXECUTIVE COMMITTEE.

ROBERT A. JOHNSON, Chairman.....Of Colby & Johnson.  
SAMUEL W. SAXTON.....Of Saxton, Smith & Co.  
CLEMENT B. BISHOP.....Of Carrow, Bishop & Co.  
JOSEPH B. BOWDEN.....Of J. B. Bowden & Co.  
GEORGE R. HOWE.....Of Carter, Sloan & Co.  
CHARLES G. LEWIS.....Of Randel, Baremore & Billings.

THE JEWELERS' CIRCULAR is the exclusive official paper of the Jewelers' League, and has been selected for the publication of all matters of interest pertaining thereto. Letters or inquiries pertinent to its business or purposes, and which might interest the trade or inquirers, will herein be answered. Address Jewelers' League, Box 3,444, P. O., New York, or the office of THE CIRCULAR.

AT THE regular meeting of the Executive Committee held Oct. 3d, 1884, the following members were present: President Woglom and Messrs. Johnson, Lewis, Howe, Bowden, Saxton and Sexton.

In compliance with the wishes of many members of the League, an extension of the time was ordered, for the payment of assessments Nos. 36, 37, 38, 39 and 40, (\$10.00) closing Oct. 20th, 1884, for the period of one month (the extreme time allowed by the constitution.)

The above assessments will, therefore, close November 20th, 1884.

Treasurer reported balance in General Fund \$2,762.14.

Nine (9) changes of beneficiaries were granted.

Two (2) applications were rejected.

Six (6) applications were referred.

The following 20 applicants were accepted:

H. H. Horst, A. Lindo, I. Lindo, C. J. Shelton, New York City, N. Y.; F. J. Hutchinson, Hornellsville, N. Y.; F. Krementz, Newark, N. J.; S. H. Megie, Plainfield, N. J.; F. Schober, Philadelphia, Pa.; O. C. Boillotat, Milford, Pa.; E. B. Towle, Newburyport, Mass.; G. K. Ballentine, Grafton, W. Va.; W. S. Pyle, Dublin, Md.; F. F. Bon-

### Sight.

WHAT THE OPTICIAN SHOULD KNOW ABOUT OPTICS.

Based upon an extensive hospital experience in Austria, Germany, England and New York. By C. A. BUCKLIN, M. D., New York. Author of Detection and Correction of Visual Imperfections, Cause and Cure of Cross Eyes, Effects of Color on Distance, and Monograph on Astigmatism.

Continued from page 245.

MINDEN, Oct. 8th, 1884.

Dr. C. A. Bucklin:

DEAR SIR—I take advantage of your kind offer in THE JEWELERS' CIRCULAR AND HOROLOGICAL REVIEW, to ask you a few questions concerning a young man of this place.

Not long since this young man had a severe attack of fever, and, when convalescent, very imprudently injured his eyes by almost constant reading. As a consequence his eyesight is now—at the age of 27—like that of extreme age. Although the iris and cornea both appear perfectly clear, and even the muscles of accommodation seem, but slightly impaired, this young man cannot even recognize a familiar face at six feet distance, and no glasses in my assortment (which is small) seem to benefit him in the least. The best he can do with the test letters is to read very black inch letters at the normal distance—or 14 inches, and even these he does not see distinctly.

If you can benefit this young man's case in any way please let me know through THE JEWELERS' CIRCULAR as soon as possible.

Yours respectfully, EDWARD ETTER.

P. S.—Since writing the above I have ascertained that the young man can see best at 7 or 8 inches distance; at this distance he can read the printed address on the envelope of this letter. E. E.

The fact that one can read fine print at seven or eight inches only would appear to indicate excessive myopia (near-sight). It is, however, true, that persons having degrees of far-sight requiring convex glasses No. six will be able to read at seven inches by straining. Such a person sees very badly at a distance, and can only see near objects. The conclusion, therefore, is that he is myopic, which is wrong.

It is easily understood how a person having excessive myopia could have the above symptoms. A person having a high degree of astigmatism will frequently give the same history.

A person having BAD vision from any cause may give these symptoms.

This apparently unreasonable statement is explained in this way: The person seeing poorly finds by bringing the observed object very near he causes his accommodation to be forced to the highest point; by doing this his pupils are made to contract to the greatest possible extent; thus the indistinctness of the retinal image caused by the circles of diffusion resulting from the visual defect are in a large degree compensated for by a "pin hole" pupil.

The vision in such cases is also greatly improved by causing the patient to look through a pin hole in a card.

The only way to determine the cause of such symptoms is to exclude far-sight by the use of convex lenses; if all convex lenses make distant vision worse, far-sight does not exist. If concave lenses fail to improve distant vision, then you may conclude that no degree of myopia exists which can be corrected.

Having excluded far-sight and near-sight, you exclude astigmatism by calling the attention to a clock dial at some five or ten feet distance; if there are any two figures directly opposite of each other which are darker than the others you may safely conclude that the person has astigmatism. I suspect in this case excessive myopia, which has followed an inflammation of the sclerotic and choroid coats of the eye; these coats having become softened have allowed the eye-ball to stretch and become elongated, thus causing myopia.

Without some experimental data gained by the trial of concave

and convex lenses, I could not give any directions of a practical nature which would enable the enquirer to benefit his patient. Would, however, be pleased to hear more definitely from him.

The following letter is from a gentleman who never has had any previous experience in correcting astigmatic defects. He is miles from any reliable expert, and he has succeeded with the *Ophthalmoscopic Test Lenses* in making a young man see who was little better than blind, who probably never would have seen had not this gentleman had the courage to attack the subject of astigmatism.

WAPAKONETA, O., Oct. 16th, 1884.

Dr. Bucklin:

My astigmatic customer resides 14 miles distant, and only came to see me to-day, which explains the delay in answering your very kind and instructive letter of Oct. 3d.

My customer (a young man of 18 whose eyes were always as they are now) cannot see to read any of the letters on the visual test at 20 feet, and no plain convex or concave lenses will in the least improve his vision at that distance. The fan lines at a few feet distance show the horizontal lines heavy, and vertical lines appear pale and thin, and continue thus as far as he can see them (about 20 feet.)

*The Right Eye*—Convex cylindrical lense either 8+ or 10+, axis 90°, corrects the astigmatism, *i. e.*, make the fan lines appear normal and enable him to see the letters L on the visual test. The addition of plain convex lenses make vision worse, but for reading at 13 to 17 inches the addition of either 20 to 24 convex lense improves the vision at that distance.

*Left Eye*—Convex cylindrical lense 14+ to 18+ corrects the astigmatism, axis 110°, and enables him to see the block letters XL on visual test at 20 feet, and no combination will produce as clear a vision at 20 feet as the above. For reading at 13 to 17 inches the addition of a convex lense 10 to 12 improves the vision and enables him to see fine newspaper print.

My idea of the combination required for reading is:

*Right Eye* +10 concave, +24 convex, axis 90°.

*Left Eye* +14 concave, +12 convex, axis 110°.

Pupillary distance, 2 $\frac{5}{8}$  inches.

And for seeing at a distance to omit the convex combinations and use cylinders alone. I think he desires glasses for reading principally—but you can tell best which will do him the most good.

I have been a little diffusive in stating this case, but the work is new to me and I was anxious to cover all the points, which reminds me that I ought to tell that "he" can read ordinary print at 10 to 14 inches without glasses, but it is straining on him; convex lenses help him little or nothing. Very resp'y yours, HENRY MOSER.

Concave nor convex lenses not improving distant vision, we are forced to the conclusion that neither myopia nor far-sight exists. It is a case of simple astigmatism.

The age of the person being only 18 years, we would not suspect any reduction in the power of accommodation. The experiment of convex lenses improving vision at the reading distance, is evidence against our conclusion.

The last remark strengthens, however, our first conclusion. He can read at fourteen inches by straining; convex lenses do not help him. My conclusion is that he should have the cylindrical correction required. The axis of the lenses being plainly marked and they should be set in round frames, so that if the patient has deceived himself as to the proper axis it can readily be corrected by rotating the lenses in the frames.

He mentions the pupillary distance as 2 $\frac{5}{8}$  inches, which was measured by "The Pupillary Distance Measure."

This instrument consists of two disks with a fine slot through the middle of each. A lamp or object is observed with the left eye through the left disk; the other disk is cautiously slid inward till the object appears double and the pupillary distance is observed on the scale. If the two objects be exactly under each other or only lack two or three inches of being under each other the muscles of the eye may be said to have their normal relative strength.

The following case is very interesting: Mr. B. is a hypercritical optician, he has every possible optical appliance. He was induced to make a study of optics owing to his own troublesome vision; he had found and exactly measured a slight astigmatism which he had but still his eyes were very troublesome. He thought that the pupil-

lary distance measure was an entirely superfluous instrument. I directed his attention at a gas flame some ten feet distant through the *pupillary distance measure*, and the *lateral* distance between the two flames was some three or more feet; 8 of prism, base in, brought the flames together.

I gave him a pair of 36 convex with 4. of prism, for both eyes, bases in which made him very happy. He went home convinced that there was more common sense in that little instrument than he had been willing to believe.

It being necessary with these kind of lenses to grind the convex surface entirely on one side and the prism on the other, a curved or hollow appearance is frequently given to surfaces, which can only be overcome by carefully centering the lenses for the working distance.

There are many watchmakers who complain of the following difficulty: They have no trouble in writing or reading, but to use an eye-glass in their watch work causes them great fatigue. The difficulty is explained in the following way: Some have a slight myopic astigmatism which is increased sufficiently by glancing through the strong eye-glass, sufficiently to cause the vision to be indistinct. Others who have eyes which are perfectly normal have a conformation of the orbit which always causes an eye-glass, when seized by the orbicular muscle, to deviate considerably from the axis of vision, thus producing an astigmatic effect by directing the visual axis slantingly through the lense. These defects can be corrected by slightly changing the form of the lense holder or by the use of a cylindrical lense. These defects escape the attention of the most expert oculists, because when they test the vision for the distance it is found to be perfectly normal.

---

## A Review of the Experiments of the Old Masters of Horology.

*Continued from page 284.*

### 6. THE ISOCHRONISM OF THE BALANCE VIBRATIONS AND THE CYLINDRICAL BALANCE SPRING.

The arcs of vibration of the balance decrease in due ratio with the length of time that the watch has been running, because its frictions increase by the drying and thickening of the oil, in consequence of which the train cannot communicate its full force to the regulator, which will, beside this, meet with another and new resistance to its activity, the thickening of the oil at its own pivots. The jars which a watch experiences when worn, and which a chronometer suffers on board ship, also disturbs more or less their balance vibrations, and, consequently, more or less change the amplitudes of the latter. These changes of amplitude are very injurious to the regularity of rate of timepieces intended for the exact measurement of time. Two distinguished horologists, however, instituted experiments in the premises and discovered a way how to make of equal duration the large and the small vibrations of the balance—in other words, how to render them isochronous.

An appropriate isochronism of their balance vibrations is the chief requisite for the exact performance of chronometers. The two celebrated artists, to whom we owe the discovery of the isochronous motion of the balance spring, arrived at the same results by two different ways.

The method of Pierre LeRoy is the one most generally employed, and is based upon the observation that a very short spring, which is of a uniform thickness throughout its entire length, is in a far greater degree acted on by the balance vibrations than a longer one; the larger vibrations are therefore accomplished in a shorter time than the smaller. A very long spring, on the other hand, is acted on far less, or in a far smaller degree, than the former, and therefore the large vibrations require more time for being accomplished than the smaller. But between two extremes there is a medium in which the

large and the small arcs of vibration are of an equal duration; and practice has fully confirmed these truths.

Ferdinand Berthoud's method of rendering the balance spring isochronous is based upon a principle entirely different from the preceding; he produced isochronism with the shape of the spring, not with its length. Berthoud made the coils of the balance spring increasingly thinner, tapering them in progression with their distance from the center. A spring shorter than the one employed by LeRoy might thus be rendered isochronous by his method.

Both methods can be used to advantage, although that of LeRoy is preferable by reason of the greater convenience it offers to the watchmaker, as he can use a spring of uniform thickness of coil. It may occasionally happen, however, that he is forced to have recourse to Berthoud's method, if the available space in the watch should happen to be too scant to allow the employment of any other kind of spring; but he will be sure to meet with another very great difficulty of execution; the thickness of the spring must decrease in a very exact and thoroughly uniform progression.

We will at some future time come back to the subject of isochronism, when we intend to elucidate the medium most appropriate between the duration of large and small balance vibrations; experience teaches that in order to produce a regular rate of a chronometer for any length of time, it is best to deviate to a certain point from the principle of perfect isochronism.

Fig. 18 represents the shape of a balance spring for chronometers. It will be seen that this spring is cylindrical, because by this form the single coils are less exposed to disturbances, and they will not touch each other even by violent concussions. At the same time the watchmaker can with greater facility manufacture a spring of this shape than a flat one. (Although it appears that the spherical form allows the greatest elasticity to the spring, and permits the balance more freedom than any other). Either gold or steel can be used as material; when using steel, it may be hardened either by fire or by hammering. There is less danger of rendering the spring fragile by hardening it by pressing. Making the spring from steel is at the same time the most convenient and best way, as the flattened and hardened material of every diameter can readily be obtained anywhere. Jurgensen used 16 and 18 karat gold for many springs he manufactured, and he assures us that he always employed this metal with great satisfaction, as it assumes an elasticity which leaves nothing more to be desired, and is in no manner inferior to untempered steel. Although the manufacture of gold springs is connected with far greater difficulties, they possess one great advantage in that they are not attacked by rust, which will invariably occur sooner or later with chronometer steel springs.

When 18 karat gold has been alloyed with very pure copper, it will retain its elasticity completely.

It is next to impossible to determine beforehand the exact length of the balance spring, as its several proportions depend upon the size and weight of the balance, as well as upon the thickness of its pivots and shape of the holes. Approximately correct may be assumed the proportion, by considering the size, or the diameter of the cylindrical steel spring, as being equal to one-third of the balance diameter and making it of 8 or 9 coils. Should the watch or chronometer be unduly flat it becomes necessary to make it of less coils; in this case, however, the latter must be of a greater diameter, so that the length of the spring shall amount to fully the ninefold of the balance diameter. The flat or over-coil spring of Breguet is made of 10 or 11 coils, and its size is to be so that it measures from 1 to  $1\frac{1}{2}$  coils beyond the radius of the balance.

Experience teaches that with cylindrical balance springs, isochronism is more easily established than with flat springs, as the coils of the former lie at the same distance from the spring's center, and,

consequently, the motions of the coils will always remain equal among themselves. Breguet also tried to impart a greater isochronism to the flat balance spring by the ingenious disposition shown in fig. 19, and the eminent success he attained thereby is of very great importance, because of the tendency at present to manufacture flat timepieces, in which the cylindrical spring can no longer be employed. Breguet's disposition consists in bringing the outer coil back to the center, by which, beyond question, an excellent effect for the uniform flexion of the coils during the activity of the spring is produced.

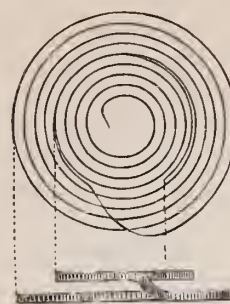

FIG. 19.

It is perhaps worthy of note that flat springs with a greater number of closely laid coils are more easily made isochronous than those of an equal length, the coils of which are more open, however, because the spring whose coil remains nearer to the center develops during its activity more uniformly in the flexion of its coils, than one whose coils are spread over a larger area.

In the representation of the cylindrical spring (fig. 18), *a* is the upper and *b* the lower end; it shows at the same time how the two ends must be curved toward their fastening points. The fastening of the ends of such a spring in the collet (of which fig. 20 gives both a side and an upper view), and in the stud (of which fig. 21 gives the same two views), must take place at the same distance from the center of the spring, as where the motive power exerts itself upon the lever of the balance. With the free chronometer escapement, therefore, the point of fastening the springs can be determined by the size of the roller.



FIG. 20.

An equality in the motion of the spring during its activity is produced thereby. Concerning this subject, Mr. Martens remarks, that attention must be paid to locate the ends to be fastened upon a line imagined as drawn to the center of the spring or else at right angles to each other. This is also applicable to flat springs, because such a position of the ends to each other materially facilitates regulating.



FIG. 21.

## 7. HOW TO MAKE A BALANCE SPRING ACCORDING TO MARTENS.

### a. Making a Cylindrical Spring.

As material for a cylindrical balance spring choose a smoothly drawn, highly polished, so-called spring wire, which can be purchased of every desired thickness, and make a cylinder of brass, the diameter of which is equal to one-third of that of the balance, and it is to be about twice as high as the balance spring is to be. Drill a hole near each end of the cylinder, cut in a screw thread and insert two screws. Then mount the cylinder upon a turning arbor in the lathe, and fasten the ends of two spring wires to the cylinder by means of one of the screws, firmly wind up the two wires side by side and fasten them with the other screw at the other end. It occasionally happens that the place in the timepiece is too contracted for the required number of coils of the balance spring, so that between them a space equal in thickness to one coil could be left. In this case it becomes necessary to take as companion wire a thinner one than that for the spring, and to wrap the two in the indicated manner upon the cylinder. When it is ascertained that the dispositions made will result in the height desired of the spring, we proceed to temper it as follows:

Tightly inclose the cylinder in a sheet iron box filled with fine charcoal dust, and heat it in a charcoal fire until satisfied that the inclosed cylinder is red hot; quickly open the box, take out the cylinder and expeditiously submerge it vertically in water. Then grind the coils clean on top, which can be done with soft wood and coarse rouge, polish them with finer rouge, take out the screws and take down the balance spring. Next grind and polish the coils interiorly with soft wood and rouge upon a cork, take another cylinder from the one upon which the spring was hardened; this

cylinder must be a trifle larger than the original one, place the spring upon it and expose the whole upon the bluing plate over a flame, until the spring is handsomely blue, after which let it cool.

After this has been done, the ends of the spring are to be reduced into their proper shape. For this is to be used a pair of pliers with a hollow and a raised jaw. Both jaws must be a little smaller than the arc of the bending which the spring is to receive. Place one of the spring ends to be bent into the pliers, and expose it over a flame until the jaws begin to turn blue; then let it cool off and the end of the spring will have received the requisite shape. Should the curvature be not yet as desired, the treatment is to be repeated. In the same manner treat the other end of the spring.

Balance springs manufactured in this manner are the best by all odds; a fairly serviceable spring can also be made by hardening the wire by drawing, after which it is to be nicely polished, wrapped upon the cylinder and blued. When working by this method, however, it is necessary to make the cylinder somewhat smaller than of rights it should be; the spring, after having been loosened, will to a certain degree uncoil; it is also necessary to examine after a time the rate of the timepiece for which such a spring is used, as the latter will gradually lose a little of its activity.

To sum up: A very careful treatment and skill in the work are indispensable conditions for the manufacture of a nice and truly cylindrical spring.

#### b. *Making the Curves of the Flat Spring.*

As the precise length of a balance spring cannot be determined beforehand, it is to be established by practical experiments. For this purpose bend, after you have reduced the spring to its approximate correct length, the outer coil upward, and place it in such a curve around the center of the spring as is required by the distance of the fastening point in the stud from the center, fasten it, mount it upon the balance and examine if the balance vibrates with the necessary speed. In case that you have not been successful, alter the length of the spring until the vibrations are approximately correct. Next, the curvature of the outer coil is to be made in accordance with the shape given in fig. 19. In order to bend this knee, take a pair of strong tweezers, place the spring upon an ivory or horn plate, seize the spring at the place where the curve is to be bent, and with a pair of pliers carefully draw the end straight upward. The first bend will thus be produced. Next seize the spring at the place where the second bending is to be made, and bend the end carefully downward. You now have made the knee. The other bend is to be made as sketched in fig. 19.

In order to attain a certain proficiency in bending a spring à la Breguet, it is advisable to practice beforehand with old springs; first attempts generally miscarry.

#### THE MOTIVE POWER.

##### *General Remarks on Motive Power According to Jurgensen.*

In order to restore the loss of power experienced by the pendulum of a clock, which loss is occasioned by friction and resistance of air, a periodically renewed quantity of power is imparted to the pendulum by a succession of wheels and pinions in increasing velocity through the escapement. This power must be sufficiently large to conquer the inertia of the train and friction so as to sustain the velocity of the motion required of the pendulum. It is only in rare instances that the quantity of motive power necessary for the propulsion of a clock can with precision be established by experiments. It is difficult to estimate the quantity of the friction of the wheel work, escapement, pendulum and the inertia of the train, and it is consequently still more difficult to calculate the power necessary for conquering them.

The motive power is generated either by means of specific gravity or by elasticity—that is, either by weight or by spring. Weights are used for stationary clocks; springs are employed for those exposed to jars. The former operate by a cord which is wrapped around a cylinder connected with the main wheel. The effect of a weight is

invariably the same, and the motive power generated with it must be considered as the most uniform, and therefore weights should always be preferred to springs whenever they can conveniently be employed. Of course, for watches, only springs can be employed; they operate upon the train either directly or by the interposition of a chain wheel—that is, a fusee.

(*To be continued.*)

## The History of Goldsmithing.

*Continued from page 288.*

THE PERIOD OF THE MEROVINGIANS AND CARLOVINGIANS. THE CENTURIES PRIOR TO THE YEAR 1,000.

### 1.—*Merovingian and Carolingian France.*

WHEN THE Frankish kings, the descendants of Mervig or Merovaens (who ruled about the middle of the 5th century), had taken full possession of the rich countries which they had conquered, and thereby outlined the primary foundations of the French monarchy, Gaul, which had for a long time been a Roman province, was already far from being in that state of barbarism in which Julius Cæsar had found it at the time of his conquest. Stimulated by the civilizing influence of the metropolis Rome, industry and the liberal arts had rapidly spread, and constituted what we to-day call the "Gallo-Roman" art.

Gaul had already its goldsmiths of renown. One of the most celebrated appears to have been a certain Mabuinus, who lived in the third century. Perpetuus, bishop of Tours, who died in the beginning of the next century, mentions him in his testament, as having constructed a large golden cross for his church.

Fifty or sixty years later, Childebert, having been victorious at the battle of Narbonne, seized a large and rich booty, from which we can see how wealthy even at this early time the churches of Gaul were in pieces of goldsmiths' work. The list of precious objects seized by Childebert mentions sixty chalices, fifteen patens, and twenty boxes for evangelists. We must remember, however, that the greater portion was of Visigothic workmanship, because Childebert was victorious over Amalarich, the king of the Visigoths, and this was doubtless the same treasure which Clovis found at Toulouse after having defeated Alarich.

The beautiful industry of goldsmithing appears to have been in great favor under the kings of the Merovingian dynasty. We find ample records of it from the sixth century forward—that is, from the century when the children of Clovis began to reign. Gregory of Tours states that during a visit which he paid to Chilperic, at his royal palace of Nogent, the king showed him a very handsome gold plate ornamented with jewelry, which had been wrought according to his directions; "I have caused this to be made," added Chilperic, "to enhance and to make renowned the nation of the Franks."

This example was followed by the majority of his followers. The bishops took a great pride in decorating their churches very sumptuously at their own expense, or, if too poor, they appealed to the piety and munificence of the princes, who generally responded with a donation of utensils and sacred vessels.

In this same sixth century, we hear of Syagrius, bishop of Autun, covering with gold and ornamenting with mosaics the eastern portion of his church, which was soon afterward imitated by Didier, bishop of Auxerre. This latter, a kinsman of Queen Brunehilde, and, through her, of the kings of France and Burgundy, appears to have been one of the wealthiest and most lavish of the prelates of his time. His wealth was so great, historians tell us, that there was not a church of any importance, either in Burgundy or in Aquitania, which had not received a donation from him. The objects of goldsmiths' work which he caused to be made for his own cathedral were as varied as they were beautiful. A very ancient manuscript, still preserved in the archives of Auxerre, contains a complete inventory. This docu-

ment is very precious on account of the details it contains of the sacerdotal furniture and vessels used at this period. Beside the chalices, lamps, covering of the altar and reliquaries, the use of which was just commencing, beside the plates, patens, basins, pans, and a variety of other sacred vessels, such as the *ichidaria* and the *schidones*, the nature and purposes of which are to us unknown, we read of buckets and vessels for washing, special vessels (*recentoria*) for wine, others for water (*bacchonica*), employed in the celebration of the holy mass, of salt cellars or vessels for blessing the salt, spoons for stirring the wine in the chalice, forks (in their literal sense), the use of which we do not at present know, down to foot-stools, of goldsmith work, and different kinds of gorget, which at that time pertained to the clerical costume.

Many of these objects were ornamented with figures in chasing; some were of niello, others engraved. According to the description just quoted, a large number represented temporal and even pagan subjects—sorcerers, Olympian gods, etc., and bearing Greek inscriptions. This would seem to indicate that they had not been manufactured for their present purposes, but were simply treasures hoarded by reason of their great value and beauty, although Gaul at that time possessed goldsmiths of eminence. We mentioned one, Mabuinus, who lived in the third century. In the sixth century we find Thorsomodus, whose name was engraven on a large silver plate, of the weight of twenty-seven pounds, which Queen Brunehilde offered as a present to St. Germain of Auxerre. Brunehilde also donated to the cathedral of this city a very beautiful chalice of onyx mounted in gold, which sufficiently attests the great estimation in which the workmanship of the goldsmith was held even at that time.

Limoges was at that time one of the towns of Gaul (or of France, as we shall hereafter call the country), where the working of the precious metals had attained to a high state of development. It possessed a mint, the striking of coins being at this time confided to the goldsmiths, the most ancient coiner, whose name has descended to us, was Abbon, although we know almost nothing of his works. St. Elias was his pupil, however, which honor sufficiently entitles him to be preserved from oblivion.

St. Elias, the illustrious canonized goldsmith, who, as such, has become the patron saint of the trade, was born at Limousin toward the end of the sixth century. Raised in the school of Abbon, he appears to have settled, while still young, in the north of France, where he wrought several noteworthy pieces of work. On account of his relationship Bobbon, the treasurer of King Clotaire II., recommended him to the king, by whom he was engaged as a coiner and for whom he manufactured various pieces of goldsmith work.

The favor which St. Elias enjoyed under Clotaire increased under the reign of the following king. Everyone is acquainted with the history of the famous chair ordered of the saint by King Dagobert. This chair was to be wrought entirely of gold, and ornamented with jewelry. According to the custom of the times, the king caused to be delivered to the saint the quantity of gold considered necessary for the work, and in due course of time the artist delivered the chair as ordered; the king was overjoyed at the exquisite workmanship, but still more so at the probity of the workman, who returned half the gold to the royal treasury, by which we are led to think that the kings of that epoch were not accustomed to be served with strict honesty, unless he founded this honesty largely on alloy.

There has been preserved for a long time at St. Denis a chair called Dagobert's chair, which it is said is the one manufactured by St. Elias. It is doubtful, however, whether it has descended to us.

Thenceforward the favor in which St. Elias was held knew no limits. The king, who had all confidence in him, made him his minister, and he was afterward appointed to an episcopate, the bishopric of Noyon, which he filled for many years.

All these dignities, however, did not prevent him from continuing his cherished pursuits of the art of goldsmithing, although he worked only for the church. None of his works authenticated as such have

come down to us, but we still possess the list as well as the description of the pieces manufactured by him.

St. Owen, who wrote a very interesting history of the life of the goldsmith saint of Limousin, mentions a number of articles which he wrought for the king—purses, belts and other personal ornaments, which he enriched with gold and jewels. Concerning his pieces for ecclesiastical purposes, St. Owen mentions among the most important the shrine, entirely covered with gold and jewels, which he made for St. Martin of Tours, also that of St. Denis, the first bishop of Paris, and other saints of the same diocese, to wit: Saints Severin, Geneva, Columbus; next, in other provinces, Saints Julien, Brice, Piat, Quentin, Lucius, Maximin and Lollien.

St. Elias also worked for the basilica of St. Denis, the favorite church of Dagobert, for which he made a gold cross of over five feet high, of exquisite work, and entirely covered with jewels, which was placed behind the main altar.

In the diocese of Limoges, Chatelard, who is reputed to have been born in the same place with St. Elias, boasted of possessing a chalice and a cross made by the latter. Various other churches also felt honored in possessing work by his hand, which, of course, has been swept away by the vicissitudes of over one thousand years; we can simply add a sketch of the cross said to have been manufactured by him, as being illustrative of the style of goldsmithing of the seventh century; it will be seen that it largely consists of filigree work.

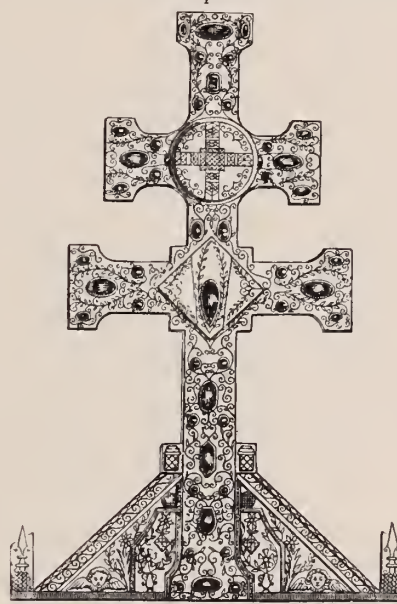

FIG. 16.

goldsmith, and refer the student of history to the chronicles of the bishops of Auxerre for full data on the subject. Coming down to the present day, the writer knows of several goldsmiths in Maiden Lane who should take pattern by their patron, St. Elias, and try to be canonized, although the biblical verse that it "is easier for a camel to pass through the eye of a needle," etc., prompts itself to him at this inopportune moment.

This leads us to the dawn of the Carolingian period. We would at once commence with the reign of Charlemagne if we had not, in a piece of work a little anterior to his reign, found a new process applied for the purpose of decorating certain pieces of goldsmiths' work.

We already mentioned, in a preceding number of *THE JEWELERS' CIRCULAR*, that the Byzantine goldsmiths had invented and with great skill practiced the art of enameling. It was but seldom that their enamels were applied immediately upon the body of the piece itself. It was often manufactured and mounted separately, set in little boxes, so that it might be used for decorating all kinds of work. They were thus used in the same manner as are to-day the ready-made jewel holes of a watch, and the Byzantine goldsmiths transacted quite a lucrative business with them. The goldsmiths of other countries, to whom the process of enameling appears to have been unknown, made use of them to embellish their work; this explains why we often find in antique work enamels evidently Byzantine, mounted on pieces of work wrought by western goldsmiths.

The earliest piece of enamel-ornamented work is a small reliquary of the eighth century, presented to the cathedral of Sion by one of

its bishops, who died in 790—the bishop Altheus, who is said to have



FIG. 17.—Front View.

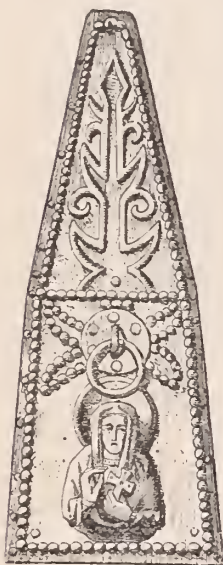

FIG. 17.—Side View.

been an uncle of Charlemagne. One of the faces of the reliquary, which we here reproduce, figure 17, represents the Holy Virgin and St. John, relief figures, accompanied by inscriptions in Roman letters. The opposite side has inserted three settings of *cloisonné* enamel, the larger two of which form irregular squares. The third is a small circular medallion. Nothing is more simple than the setting and the manner in which the boxes are applied upon the plane surface of the object.

The above described work, as far as beauty is concerned, contains nothing of interest to either the goldsmith or the designer. Each one of the larger two squares encloses two busts of saints, who are not distinguished by any attributes. All the description that can be given is that the

heads of the figures are surrounded by the saints' halo, and each figure carries a book in the folds of his habiliment, which might seem to indicate that they are to represent the four evangelists; the fifth figure closely resembles the other four, and is not any better characterized; all the five faces are void of expression; they consist of



FIG. 18.

white enamel, the features divided by the *cloisonné* lines; the nose is indicated by two simple lines of wire, without indicating the nostrils, the eyes are two small ovals of a darker enamel, and the student will at once perceive that he is examining a specimen belonging to the very infancy of the enamellers' art. We have mentioned it for the twofold reason, first, because its enamel belongs to the kind we spoke of above, and, second, it is a specimen when the art was in its childhood.

We will not tarry any longer, but at once hasten to that epoch when the rising sun of civilization began to throw its first rays athwart the sky hitherto obscured by the densest of nights. The colossus of those times, Charlemagne, the powerful, the extraordinary genius, has assumed the reins of government of the Western Empire, and is everywhere opening schools of learning, promoting art and science, and appears emulous to add the glories of civilization to those of his arms.

The art of goldsmithing was not neglected by him; one of his ordinances required that goldsmiths shall establish themselves in all the jurisdictions of his empire.

Although on ordinary occasions he affected a simplicity that almost amounted to shabbiness, as far as his own person was concerned, yet he thoroughly understood how to surround himself on solemn occasions with all the pomp and circumstance of rank. His historian, Eginhard, says that on such occasions he was wont to dress in the richest of costumes covered with gold and jewelry. Costly embroidery adorned his cloak, which was clasped over his breast with a gold buckle. On his head he carried a diadem set with emeralds, sapphires, agates and pearls. Even his buskins glittered with jewelry, and in his hand he carried a baton terminating in a gold apple exquisitely chased in lieu of a scepter.

The crown of Charlemagne, represented in the accompanying sketch, figure 19, and of which we gave a description in THE JEWELERS' CIRCULAR, Vol. XIII., is still preserved in the Imperial treas-



FIG. 19.

ury at Vienna, Austria; and its authenticity is beyond a doubt, although archeologists say that it has undergone several alterations at the hands of the various emperors who have worn it.

Also his sword is kept in a museum at Paris, although only the hilt and guard appear to be original.

If Charlemagne was imposing in his ceremonies, he was none the less so in the decoration of his numerous palaces, in which he collected the rarest and costliest objects. Particularly that of Aix-la-Chapelle, which he built to be his principal residence, he embellished in the handsomest manner. The columns, brought from Ravenna, were of the rarest marble, and the furniture of the most sumptuous kind that could be gotten at that time. Among other things there was a gold table, the leaf of which was divided into three circular compartments, representing the earth as it was known at that time, the motion of the stars, and of the planets. Two silver tables represented, one the plan of Rome, and the other that of Constantinople. Charlemagne, at his death, bequeathed the latter two to the church of St. Peter, in Rome, and to the cathedral at Ravenna. The gold table fell as heirloom to Louis le Débonnaire or the pious (778 to 840, son of Charlemagne by his third wife, Hildegarde), but after him his son Lothaire cut it up and presented the pieces to his followers.

Charlemagne made numerous donations of goldsmiths' work to the principal churches of his vast empire. An old tradition asserts that he presented to twenty-four different abbeys pieces consisting of the single letters of the alphabet. This tradition is not well proven; still, it would appear to be true, if we recall to mind several little circumstances, among which that an inventory of the treasury of the Holy Chapel of Paris, in 1480, mentions, without further explanations, two pieces of filigree in the form of M, ornamented with jewelry; a bull of the twelfth century fulminates excommunication



against the thieves who had robbed the abbey of Brioude of a reliquary in the shape of a C, and, finally, there is still preserved in the treasury of the ancient abbey of Conques (Aveyron) a reliquary resembling in shape the letter A, which has always been known by the name of Charlemagne's A.

Figure 20 represents the letter, and even if the resemblance should be purely accidental it represents at all events a very ancient piece



FIG. 20.

of goldsmithing. The lower traverse bar has been added subsequently, but the two principal limbs and the large boss uniting them are of undoubted Carolingian workmanship.

At his death it is said that Charlemagne desired that the treasures which he had accumulated should be divided among the twenty metropolis of his empire, but the church which he desired to enrich in preference to all others was that of Aix-la-Chapelle, which city was his favorite as well as his last residence, and the construction and decoration of its church was one of his cherished ideas. All its altars, all its interior walls, displayed a profusion of gold and silver, and it contained an unknown wealth of sacred vases, reliquaries, lamps, candelabras, sacerdotal vestments, etc. Precious little of all this is left to-day, as the church has been stripped repeatedly, together with every other species of wealth which it happened to possess at the time.

Charlemagne, in tenor with his wish, was, at Aix-la-Chapelle, placed in a vault constructed for this purpose under the dome of the new cathedral. His body, embalmed and arrayed in magnificent habiliments, and accompanied with all the attributes of his sovereign power, was set upon a throne of gold. A copy of the Evangels, magnificently bound, was placed upon his knees. His hand rested upon a scepter, and before him was suspended a golden shield.

So much wealth tempted the cupidity of his successors. Otho III. was the first to despoil the sepulchre, but he contented himself with taking the golden cross which the emperor wore suspended around the neck. The next grave robber was Frederic Barbarossa, who caused Charlemagne to be canonized at the same time; he thought undoubtedly that the latter, after having been pronounced a saint, should rest content with the boundless wealth of celestial glory, and he could therefore well dispense with the many valuable objects of mundane lucre which he had collected around him.

Goldsmithing continued to flourish under the successors of Charlemagne. Louis le Débonnaire in particular appears to have expended large sums for this purpose. All the historians of the time mention the great value of the treasures which he had amassed, and how he loved to display them on all occasions. He overwhelmed with presents Pope Stephen IV. and the Danish king Harold, who, together with his wife, was baptized after him. In the inventory of

presents, still preserved, we read of a diadem and a flexible belt ornamented with jewelry, a large collar, a hoop of gold twisted for the neck, bracelets, etc. Next, as equipments for battle, we find sword hilts of gold, silver and ivory, sword belts ornamented with precious stones, gold sword scabbards, etc.

Among the precious objects with which, at this epoch, the chapel of the emperors, kings and powerful vassals were ornamented, we frequently see mentioned altar reliquaries overlaid with sheets of gold or silver, crystal or enamel.

The altars thus mentioned were generally small portable ones, which the princes, who were at that time eternally embroiled in wars, carried with them in their campaigns, so that the chaplains might celebrate mass at any place where they would stop for the night. They were retained in use until the fourteenth century, and several of them are still in existence; a goodly number are found in Germany: in the cathedral of Bamberg, Triers, in the museums at Berlin, Darmstadt, Hanover; next in France, in the treasure of the church of Conques, which possesses two. One of them has all the appearance of being of Carolingian workmanship.

(To be Continued.)

## Regulations Governing the Issue of Certificates of Rates of Timepieces, after October 1st, 1884.

### I.—Classes of Certificates.

The following classes of certificates will be issued with timepieces which have been deposited at this observatory for trial:

The certificate will contain a detailed statement of the results obtained with each particular movement.

In describing the position of a movement, the term "Dial up" indicates that the plane of the dial is horizontal, and with the engraved side uppermost. "Dial vertical" indicates that the plane of the dial is vertical.

The temperature of the refrigerator is approximately 40° F., that of the oven is approximately 90° F., and the ordinary temperature ranges between 65° and 75° F.

1. Class A includes those certificates issued with pocket chronometers or watches which have been subjected while rating to the following variations of position and temperature:

| Period.  | Occurs during the days of the trial. | Position.                     | Temperature.  |
|----------|--------------------------------------|-------------------------------|---------------|
| First.   | 1st to 6th.                          | Dial Vertical, Pendant up.    | Ordinary.     |
| Second.  | 6th to 11th.                         | Dial Vertical, Pendant Right. | Ordinary.     |
| Third.   | 11th to 16th.                        | Dial Vertical, Pendant Left.  | Ordinary.     |
| Fourth.  | 16th to 22d.                         | Dial up.                      | Refrigerator. |
| Fifth.   | 22d to 28th.                         | Dial up.                      | Ordinary.     |
| Sixth.   | 28th to 34th.                        | Dial up.                      | Oven.         |
| Seventh. | 34th to 40th.                        | Dial down.                    | Ordinary.     |
| Eighth.  | 40th to 45th.                        | Dial Vertical, Pendant up.    | Ordinary.     |

The trial comprises forty-five days, during which the movement is rated in five positions during periods of five days each, and is exposed to cold, warm and average temperatures. In order that the movements may assume their new rates under changed conditions, the first day's rating in the 4th, 5th, 6th and 7th periods are not used in making up the record of a movement's performance.

2. Class B includes those certificates issued with pocket chronometers or watches which have been subjected while rating to the following variations of position and temperature:

| Period. | Occurs during the days of the trial. | Position.                  | Temperature.  |
|---------|--------------------------------------|----------------------------|---------------|
| First.  | 1st to 15th.                         | Dial Vertical, Pendant up. | Ordinary.     |
| Second. | 15th to 29th.                        | Dial up.                   | Ordinary.     |
| Third.  | 29th to 30th.                        | Dial up.                   | Refrigerator. |
| Fourth. | 30th to 31st.                        | Dial up.                   | Ordinary.     |
| Fifth.  | 31st to 32d.                         | Dial up.                   | Oven.         |

3. Class C includes those certificates issued with pocket chronometers or watches which have been subjected while rating to the following variations of position and temperature:

| Period. | Occurs during the days of the trial. | Position.                  | Temperature. |
|---------|--------------------------------------|----------------------------|--------------|
| First.  | 1st to 9th.                          | Dial Vertical, Pendant up. | Ordinary.    |
| Second. | 9th to 17th.                         | Dial up.                   | Ordinary.    |

Certificates of the classes A, B and C are issued in two grades. The ordinary certificate is issued when the observed ratings show that an excellence has been obtained which is within the limits assigned in the third column of the table following and the certificates have the words "especially good" attached to them by the officer signing the certificate, when a degree of excellence has been attained within the limits shown in the fourth column.

| Class. | Condition.  | Col. III.           | Col. IV.           |
|--------|---|---------------------|--------------------|
| A.     | When the mean difference of the daily rate under the same condition of temperature and position, and during the same period, does not exceed..... | 2 <sup>s</sup> .00  | 0 <sup>s</sup> .75 |
| B.     | do. do. ....  | 2 .00               | 0 75               |
| C.     | do. do. ....  | 2 .00               | 0 .75              |
| A.     | When the difference between the mean daily rate, Pendant up, differs from the mean daily rate, Dial up, by less than.....                         | 5 <sup>s</sup> .00  | 2 <sup>s</sup> .50 |
| B.     | do. do. ....  | 10 .06              | 5 .00              |
| C.     | do. do. ....  | 16 .10              | 5 .00              |
| A.     | When the difference between the mean daily rate, Pendant up, and the mean daily rate in any position except Dial up is greater than.....          | 10 <sup>s</sup> .00 | 5 <sup>s</sup> .00 |
| A.     | When the variation for 1° F. does not exceed  | 0 <sup>s</sup> .30  | 0 <sup>s</sup> .15 |
| B.     | do. do.   | 0 .30               | 0 .20              |

In addition to the above described certificates there will be furnished records of rate for any timepieces deposited at the Observatory for such a purpose. These records are meant to indicate the performance of timepieces, and may take any form the person desires who enters the timepieces, subject to the approval of the officer in charge. When such timepieces are box chronometers, and they have been rated for a minimum period of two months, and have been rated in the refrigerator and in the oven, and there has been no daily variation greater than 2<sup>s</sup>.0 or than 0<sup>s</sup>.3 for 1° F., certificates of the class D will be issued with them.

When such a timepiece is a clock, and it has been rated for a minimum period of three months at ordinary temperatures, and has been tested for compensation in temperature, and when the daily variation of rate has not exceeded 1<sup>s</sup>.0, except there has been an attendant variation of the barometer in its case as great as 0<sup>IN</sup>.70, and when the variation for 2° F. has not exceeded 0<sup>s</sup>.30, a certificate of the class E will be issued with it.

II.—Cost of Certificates.

| Designation.  | Observatory charge. | Remarks.  |
|---------------|---------------------|---|
| Certificates: |                     |   |
| Class A.      | \$7.50              | Discount of one-third when five movements are rated at the same time.       |
| Class B.      | 5.00                | do. do.   |
| Class C.      | 3.00                | do. do.   |
| Class D.      | 7.50                | do. do.   |
| Class E.      | 20.00               | An additional charge for clock mounting will be made depending on its cost. |
| Rate records. | Per diem, \$0.10    | An additional entrance fee of \$0.25 will be charged for each movement.     |

The Outlook at Trade Centers.

THE FOLLOWING extracts from our exchanges indicate the condition of business at different important trade centers. While these do not specially mention the condition of the jewelry

trade, they indicate an improvement in other branches of business, and a continued hopefulness on the part of merchants. The jewelry trade is dependent upon the prosperity of business in general, and the conditions prevailing in the leading industries furnishes "a pointer" by which the trade can be guided. The reports are, on the whole, of a favorable character.

*Philadelphia Record*.—"The business situation is about the same as during the early part of the month. Cooler weather has quickened the distribution of some lines of goods, but there has been no general nor noteworthy activity. A very conservative feeling prevails, and transactions in all departments are on a moderate scale proportioned to well assured requirements."

*Boston Commercial List*.—"The business situation has not improved in any important particular during the month. Nearly all branches report a slow and unsatisfactory movement, and there is little prospect of any permanent change for the better this season. Some people blame the very mild weather; others say that the political excitement is the principal cause. But we can see gleams of light in the distance. The process of liquidation and adjustment through which the business affairs of the country are now passing will place them on a healthy basis, and the recovery, when it does come, will be rapid and substantial. What is now most wanted is confidence."

*Chicago Times*.—"To a considerable extent merchants are living on hope, the current sales being a good deal behind last year. They know that, owing to the 'hand-to-mouth' manner of buying that has been pursued for a long time by western merchants, supplies nearly everywhere have become greatly reduced, and as soon as the weather becomes colder they are confident that a sharp demand for dry goods, clothing, hats and caps, boots, shoes and rubbers, etc., will spring up."

*Baltimore American*.—"In the home distributive trade some departments report a fair volume of business, and in several trade centers at the West the movement is said to be measurably active; but, it is constantly observed, the persistent adherence to the conservative methods of buying that provide for current wants only, which policy, while it may secure a steady outlet for supplies, yet deprives trade of all elasticity and 'chic.' The onus of carrying stock is thus thrown upon manufacturers and importers; but, all the same, consumption is and will be steadily maintained, the course of trade for nearly a year past showing that the actual consumption during that period of all food staples, groceries, dry goods and clothing has never been greater. The aggregate amount used up, therefore, will be as large as ever before."

*Montreal Gazette*.—"We find and cheerfully chronicle some improvement in general trade, which may be sustained during the remainder of the season. At all events, there is a fair volume of business compared with the earlier stages of the year, and it has a tendency to increase."

*Minneapolis Tribune*.—"Merchandise jobbing, as a whole, compares favorably with a year ago. Groceries sell very freely, but the hardware and dry goods departments, while not particularly disappointing, are not so active as at this time last year. Both of these latter have increased. The recent business has been fairly satisfactory in the movement of merchandise. Prices show little alteration."

*Savannah Morning News*.—"During the month business was fully as active as that previously reported. Collections continue slow, and this condition of affairs is beginning to be felt more severely in commercial circles. Trading in dry goods was not up to the previous sales. The continued mild weather, it is thought, is the chief cause. Prices are quite steady."

*Nashville American*.—"Trade during the past month has been moderately good. Considerable complaint continues to be made by jobbers of the difficulty in making collections. Cotton has begun to move only to a limited extent, and money matters are as yet strident in the country. When this trouble has been removed, as it will be soon, commerce will revive very rapidly."

*Detroit Free Press.*—"Collections have improved somewhat during the past two or three weeks. There is confidence, however, in the future, and, as much money is being paid out for wheat, in time it is sure to return through channels requiring it. The change in the weather and a certainty that a low thermometer will now prevail is received with much favor in most business circles. Distributors of dry goods, clothing, boots and shoes and leather are especially rejoicing at the change as sure to bring about a quickened movement of their goods, though no heavy demand for supplies is anticipated."

---

### Traders' and Travelers' Union.

THE ABOVE company, organized in the interests of New York city merchants, has been incorporated under the laws of this State, and is purely a business corporation purposing to unite the capital and patronage of the associate merchants for mutual protection and benefit. In brief, it designs upon the co-operative plan to obtain for its members favorable transportation and telegraph rates to secure them against undue exactions under the guise of license laws or otherwise, to procure and collect indemnity in case of fatal accident, to provide against injury to or loss of baggage, and generally to acquire, preserve and disseminate valuable business information, and adopt and enforce such measures as shall promote the prosperity of the company and of its members. Members are classified so that the benefits of such co-operation may be most equitably apportioned. The term of the Union's charter is twenty-five years. The Union combines some forty classes of trade; its board of directors representing many kinds of trade, to the end that the needs of each may be intelligently considered. Its policy will be to remedy the abuses to which its members are at present subjected, and to obtain the advantages named above by means of friendly negotiation; only when this method fails will resource be had to severe measures.

A circular issued by the company states: "It is also unnecessary to particularize the many grievances caused by unjust discrimination in *freight rates*, whereby other localities have been favored at the expense of New York. In the matter of *passenger rates* it is well known that traveling troupes of various kinds, even excursionists for short distances, obtain special rates, while the merchant, his traveling agents and his customers who furnish the bulk of freight and the larger percentage of travel, are treated with no such consideration. Reference is here made to the merchants of New York. The case is different in other localities. Western railroads co-operate with the merchants of western cities, and, by means of special rates, free passes and excursion trains, both are benefitted to the injury of the merchants of New York. The Union proposes to remedy this gross injustice.

"By a business combination that can turn its entire patronage into selected channels, special rates will also be obtained for its members with *express* and *telegraph* companies.

"Reduction in *baggage rates* is a positive necessity. The casual passenger must no longer be better treated than the constant commercial traveler.

"The Union further proposes to meet a long-felt want in case of *lost or destroyed baggage*. The forms of insurance hitherto obtainable provide for but a small percentage of the damage sustained by merchants and their travelers. Trunks and packages containing valuable samples and mercantile stock are exposed to the many risks of transportation with little or no remedy in case of injury or loss.

"A special feature proposed for the *traveling salesman* is to secure for his designated beneficiaries a reasonable amount, to be paid in the event of his *death by accident* while in the prosecution of his business.

"The Union proposes, moreover, by all legitimate means, to protect its members against imposition in the guise of *local license*

*laws*, rife in certain sections of the country. Relieving members of the annoyance and expense of defending themselves, singly, in case of unjust taxation, the Union will respond for them and protect them to the full extent.

"The capital stock of this company is owned and held exclusively by prominent mercantile houses of this city."

The large number of firms already associated with the Union include E. S. Jaffray & Co., George H. Clark & Co., P. Lorillard & Co., Lord & Taylor, Manhattan Cloak & Suit Co., and other houses. The officers are: Daniel C. Robbins, president; Robert F. Austin, vice-president; J. H. T. Martin, treasurer; and John V. Cheney, secretary. Further information will be given by Mr. J. V. Cheney, 287 Broadway.

---

### How Exact Time is Transmitted.

THE DETERMINATION and transmission of exact time forms, in a utilitarian sense, is an important part of the National Observatory work. It is interesting to observe the routine followed every day by the time officer. At 11 o'clock he enters the chronometer room and spends half an hour or more in comparing and winding the chronometers. Some of these are ready to go on sea voyages, while others must undergo a long period of correction. In the room are also two clocks, a mean time and a transmitting clock. The former is never corrected, and when the *Post* reporter visited the observatory it was nine and some hundredths seconds fast. It is never over thirty seconds out of the way. Once a year it is taken down and cleaned, but is never tinkered with or "regulated." Every day its error is closely calculated by the lieutenant in charge.

At 11.40 the error of the transmitting clock is obtained. This is done by recording on a chronograph both its beats and the beats of the mean time clock. If they do not register simultaneously the difference can be determined to the hundredth part of a second. The point of a lead pencil held just near enough to the pendulum of the transmitting clock to retard it, if it is fast, or accelerate it, if it is slow, enables the officer to make the difference between the clocks just equal to the error of the mean time clock, which will be shown on the tell-tale chronograph.

At 11.50 the officer signals to the watchman on the roof and he hoists the time ball.

At 11.56 the chronograph is connected with the mean time clock, and the clicking—each click represents a second—begins.

Half a minute later the officer turns a switch and the transmitting clock is ready to be connected with the outgoing wires.

At 11.56.44 the repeater switch, connecting these wires is closed, and the beat of the next second, the forty-fifth, goes out, the first signal that the hour of noon is approaching.

At 11.58.55 an automatic break arrangement causes the clock to cease transmitting the electric current, and for five seconds there are no beats. The next click begins the last minute before noon. This click is the signal for the watchman on the roof to slip a bolt through a ring, thus fastening the ball.

Ten seconds before 12 a final adjustment is made. There is a moment's silence—then a click as the second hand reaches sixty, and the ball on the dome has dropped and the hour of noon has been flashed across the land in every direction.

It used to be the custom for the time officer to listen for the click and then press a key. This has been abandoned, and now the signal flashes direct from the clock itself. There are several telegraph instruments connected with the clock, communicating with the several telegraph companies, the fire alarm bells, and by a private line with clocks in the War, State, and Navy Department, White House, National Museum, Clerk's office United States Senate, Government Printing Office, Interior and Post-Office Departments, City Post-Office, the Pension Office, Treasury Department, Attorney-General's office, and the headquarters of the Surgeon-General. The Signal Office also gets the correct time.—*Washington Post*.

## Current Humor.

---

"A little nonsense now and then  
Is relished by the wisest men."

---

## CURIOSITIES OF ENGLISH SCHOOLS.

The London *Times* says the following were recently among the written answers in examination on Scripture by her Majesty's inspector of schools:

"Who was Moses?" "He was an Egyptian. He lived in a bark maid of bullrushes, and he kept a golden carf and worshipt braizen snakes and he het nothin' but qwahles and manner for forty years. He war kort by the air of his 'ed while ridin under a bow of a tree, and he was killed by his son Abselon as he was hanging from the bow. His end was peace."

"What do you know of the patriarch Abraham?" "He was the father of Lot and had tew wives. One was called Hismale and tother Haygur. He kept wun at home and he hurried the tother into the desert, where she became a pillow of salt in the daytime and a pillow of fire at nite."

"Write an account of the Good Samaratin." "A certing man went down from Jer slam to Jerker and he feld among thawns and the thawns sprank up and chuked him. Whereupon he gave tuppins to the hoast and said tak care on him and put him on his hown hass. And he past bye on the hother side."

## JUDGING BY APPEARANCES.

Foreigner (at fashionable American watering place)—"I cannot see why such plain, humble-looking people as some of those you have here should be willing to come to a gay place like this or be able to pay the enormous prices you charge. I should think farmers would want to save their money to buy ploughs and hoes and such things." Hotel Clerk—"I do not notice any such people here as you describe." "Why, look at that old gentleman over there. Belongs in some small village, don't he—a mere nobody evidently." "That is a very eminent member of the Cabinet." "Bless my stars! Well, who is that distinguished looking personage in a dress suit looking out the window?" "That is the head waiter."

## KEEPING IN PRACTICE.

He was out back of the barn tickling a mule's heel with a straw. "Here, get away from that mule's heels. He'll kick you into kingdom come," said a passer. "You let me alone. I know my biz." The mule blazed away and landed the tickler across the barn-yard against the fence kerswat. "There, didn't I tell you?" "Well, what if you did?" said the tickler, gathering himself up and returning to his tickling only to be raised back with more force than before. "Well, you are an infernal idiot," said the passer, starting to go. "No I ain't, stranger. I do this every morning before there's going to be a game. You see, I am a base-ball umpire, and—" "Oh, ah, well, excuse me, sir."

## AN INTELLIGENT DOG.

"Talking about the sagacity of animals," said a well-known citizen, "here's a story, Mr. Idler, which illustrates the intellectual capacity of the dog. The late Judge Smalley, who was very fond of a fine dog, one day bought a splendid English bull-dog, which he placed in a kennel close to one occupied by a big Newfoundland that he owned. Mr. Bull-dog took a fancy to Mr. Newfoundland's house, and immediately proceeded to drive him out of it. A pitched battle ensued, in which the Newfoundland dog was beaten by a large majority. Now, at this time there was kept at the American hotel a gigantic mastiff—the biggest dog ever seen in these parts. It was a quiet, well-behaved animal, and had never been known to leave the

hotel premises. Well, one fine night Judge Smalley's entire household was awakened by the noise of a desperate dog-fight. There were barks and howls and yowls of every description. Lanterns were immediately lighted and an investigation was had, and what do you suppose we found? Well, sir, that Newfoundland had gone to the hotel, told the big mastiff of his ill-treatment, and persuaded him to go home with him and help him; and the mastiff and the Newfoundland had torn that bull-dog all to pieces. He was scattered all over an acre, and no single piece was big enough to weigh an ounce. I tell you, dogs can talk to each other, in their way, and this story proves it."—*Burlington Free Press*.

## AGRICULTURAL PAPERS.

Honest Farmer—"These here agricult'ral papers don't know nothing. Anybody might see they was edited by city chaps." Mrs. Honest Farmer—"What are they saying now?" Honest Farmer—"Why, this paper says that on wet days, when a farmer can't work in the field, he ought to mend the tools, oil the harness, and pick out the decayed fruit and vegetables in the cellar." Mrs. Honest Farmer—"Well, it seems to me that's purty sensible." Honest Farmer—"Sensible! Why, what on arth is the use of picking out decayed fruit and vegetables, when it is so wet that you can't take em to market?"

## A SHILLING'S WORTH.

A fellow who came by the railroad, being a stranger, strolled about for some time on the "outskirts" of a town in search of a barber. He finally discovered one, and requested the operator to take off a shilling's worth of hair. The barber trimmed his locks very neatly, soaped up the remainder very handsomely and then combed and brushed him till his head looked as if it belonged to some other person than himself.

"Are you done?" asked the stranger, as the barber removed the napkin from his neck.

"Yes, sir," said the barber with a polite bow.

"Are you certain that you took off a shilling's worth?"

"Yes, sir; there's a glass, you can look for yourself."

"Well," said the stranger, "if you think you have a shilling's worth off, I don't know as I have any use for it, I haven't got no change, so you may just take the hair for your trouble."

On hearing this the barber made a jump for the man, whereupon he made a jump for the door which not being bolted, he bolted himself.

## A COPIOUS LANGUAGE.

The copiousness of the English tongue, as well as the difficulty of acquiring the ability to use its immense vocabulary correctly, is well exhibited in the following array of synonymous words, which, if not new, is yet a capital illustration of the nice distinctions which characterize so many of our vocables. It is no wonder that we slip occasionally, even the wariest of us. A little girl was looking at the picture of a number of ships, when she exclaimed: "See what a flock of ships!" We corrected her by saying that a flock of ships is called a fleet, and that a fleet of sheep is called a flock. And here we would add for the benefit of the foreigner who is mastering the intricacies of our language in respect to nouns of multitude, that a flock of girls is called a bevy, that a bevy of wolves is called a pack, and that a pack of thieves is called a gang, and that a gang of angels is called a host, and a host of porpoises is called a shoal, and a shoal of buffalos a herd, and a herd of children is called a troop, and a troop of partridges is called a covey, and a covey of beauties is called a galaxy, and a galaxy of ruffians is called a horde, and a horde of rubbish is called a heap,

and a heap of oxen is called a drove, and a drove of blackguards is called a mob, and a mob of whales is called a school, and a school of worshipers is called a congregation, and a congregation of engineers is called a corps, and a corps of robbers is called a band, and a band of locusts is called a swarm, and a swarm of people is called a crowd, and a crowd of gentlemen is called the elite; and the elite of the city's thieves and rascals is called the most dangerous men in the community.

---

AN EXCELLENT REASON.

Old Uncle Ben, the veteran stage-driver, was an inveterate joker and was fond of practising his art upon his passengers who shared the driver's box with him. One day his horses were toiling along a lonely country road, and just at night they passed a solitary farm house a mile distant from any other and bearing an appearance of a lack of thrift.

"There," said Uncle Ben, pointing with his whip, "there's a woman been lying in that house for more than a fortnight, and she isn't buried yet."

"Dreadful," said a passenger. "The authorities ought to attend to it. Hasn't she any friends and why don't they bury her?"

"Got friends enough, but she ain't dead; she's as lively as a cricket."

---

HOW TO HANDLE A GUN.

The first thing you do when you go out gunning with another boy is to guard yourself against accident. The best way to do this is to shoot the other boy before he has time to load his gun. Then take both guns to the nearest creek and throw them in. Throw the powder and shot in after them. If you have any matches about your clothes throw them in also. Then start at once and go home as fast as ever you can. And if you are under eighteen years, young man, the chances are, even with these precautions, that you will get both legs and a section of your back filled to the brim with bird shot before you reach home.

"How?"

Goodness only knows how, my son, I don't. I have often wondered how it did happen, but I never could ascertain. I am not here to advance ingenious theories, but merely to state cold facts; and I know it to be a solemn truth that a boy, with a single barrel gun twice as long as himself, can manage somehow to shoot himself in more places at once than a man can with a seven-shooter revolver.

"And am I going to buy you a gun?" Yes, I am; some time in the long vacation, when time hangs heavily on my hands, and I think I would enjoy entertaining you by picking shot out of your legs with a nut pick.

"But you will be very careful with it?" So is a woman very careful with an umbrella, my son, and yet science is unable to account for the startling increase of one-eyed men every summer.

---

THE WIDOW'S INSURANCE.

One of the steamers plying between Detroit and Cleveland ran over a skiff one night and drowned its occupant. When he had been identified, an agent called upon his wife to see if a settlement could be effected. She was not in tears nor prostrate with grief. On the contrary, she was at the wash-tub and in good humor. When the matter was broached she said:

"Well, now, my husband took home the washings, brought in the coal, and was of use in several other ways, and his death is quite a loss to me."

"About what sum do you feel would make you good?" he asked.

"Now, then, be honest with me," she replied after taking a moment to think. "How much will a bang-up bridal tower from here to Niagara Falls and back cost?"

"Well, \$300 ought to put you through first-class, and give you three days at the Falls."

"Well, say \$350. That gives me money for new shoes and a bonnet, and I may want to dye my hair and buy some stockings."

The money was handed over and a receipt taken, and the "tower" took place the next week.

---

THE colored brother is a creature of imitative propensities. We have long known that he is ambitious to be a Mason or an Odd Fellow; that he joins a band of music or a military company; that he buys lottery tickets and speculates in graveyard insurance; that he goes to camp-meetings, and that he forms associations which require some knowledge of parliamentary rules. But we were not aware, until we learned it from the *Arkansaw Traveller*, that he has taken a hint from presidents of companies who believe in the assertion of the one-man power, and that he has improved on the absolutism of voting by proxy. Referring to a convention recently held in Little Rock, the *Traveller* relates that during a clamor for recognition the chairman said:

"Let de cheer—let de cheer rule on dat p'int. De cheer rules dat de two gennermen kain't talk at de same time. One gennerman mus' talk an' aiter he gits dun, de udder gennerman he kin talk."

"Who's got de flo'?" demanded a delegate.

"Neber mind who's got de flo'. Keep on axin' yer unpovermently questions an' yer see who'll hab de flo'—hab all ob it dat yer kin kiver. I takes dis heah mefod fur ter 'nounce myse'f de nominee fur county jedge. All in faber ob de measure will make it known by sayn' 'I,' an' dose opposed will please gin up dar seats ter pussons what's got more sense. De 'I's' hab it."

---

HOW HE OVERDID IT.

For once the superabundant life agent has overdone it, and allowed his vaulting ambition to overleap itself. Assure a man that he will live forever and he will be satisfied with that assurance, while it is another sort of assurance that the agent is anxious to dispose of. This is the way the *Philadelphia Call* puts it:

Insurance Agent—"It's all right. The doctor says you are the best risk he ever examined."

Citizen—"The best risk?"

"Yes; soundest constitution and perfect health, you know."

"Did he say that?"

"Yes, indeed. No trouble about your case. He said there was nothing to prevent you from living a hundred years."

"You don't mean it?"

"Honest truth. Come right around to my office and I'll fix up the papers at once."

"No, thank you; it wont pay. I'm too healthy."

---

A LAWYER BADLY SOLD.

He was so hopping mad about it that he had to swallow the lump in his throat three or four times before he could speak English. When the other had patted him on the back and led him around in a circle he began with:

"Of course, if I make a debt I expect to pay it."

"Of course."

"I'm worth \$30,000, and I don't owe \$200 in the world."

"Of course not."

"Well, I was sitting in the office about 11 o'clock this forenoon, when in came a stranger. He introduced himself and took a chair. I was smoking, and it was only courtesy to offer him a cigar. He said he had frequently heard my name mentioned, and I supposed he was some gentleman from the interior of the State who wanted my written legal opinion."

"Certainly; your luminous opinion."

"He seemed rather diffident and embarrassed, and as he had not made his wants known up to noon I invited him home with me to dinner. He readily accepted."

"I see."

"After dinner I showed him all over the house, played billiards with him for half an hour, and then brought him back to the office and gave him another fifteen cent cigar, and asked him to come to the point."

"And he came?"

"He did—bless him! He handed me a bill of fifty cents from a tin shop here in town for mending the wash boiler and putting a new nose on the tea-kettle."

WEALTH NO BARRIER TO SORROW.

He was a busy man and she was a society woman. One evening he suddenly looked up from his paper and said:

"By the way, didn't we have a baby in this house about the time Midland Broad-Gauge went up to ninety-eight?"

"Yes," she said, "Oscar was born the night of the Everingham reception."

"Boy, was it?" he said, with a show of interest. "I had forgotten; must be about seven months old by this time. Where is he?"

She touched a bell, the servant appeared, and she ordered Oscar to be brought into the presence of his sire. Instead of whom the weeping nurse appeared alone, and with many tears confessed that the infant Oscar had been kidnapped in the park six weeks before, and that the most careful search, aided by advertisements in the daily papers, had thus far failed to reveal his whereabouts. Thus we see that wealth is no barrier to sorrow, and even into the homes of the rich and the great trouble creeps with its stealthy tread and sometimes breaks up a whole evening of enjoyment.

IT WAS SIMPLY ABSENT-MINDEDNESS.

"Did you see the defendant drink?" asked the attorney of the witness.

"I did not," replied the witness.

"Why, then, do you think he was drunk?"

"Because he was on his way home from the convention and attempted to wind up the door-knob with his watch-key."

"Is that your only reason for swearing that the defendant was drunk?"

"Yes; but I think that is reason enough."

"Your honor, the court," said the lawyer, springing to his feet, "the witness is unable to distinguish between absent-mindedness and drunkenness. Such evidence as this is preposterous, and if entertained would convict all of us. Why, even the court would not escape. Your honor knows that the court last night bit the end of a cucumber pickle, stuck it in his mouth, scratched a tooth-pick on his pants, and tried to light it for a cigar. Of course, your honor was thinking of a case——"

"Yes," said the court, "I was thinking of a case—a case of beer. I was absent-minded. The case is dismissed."

SHE ASKED HIM GENTLY.

Young Wife—"My dear, you were the stroke oar at college, weren't you?"

Young Husband—"Yes, love."

"And a very prominent member of the gymnastic class?"

"I was the leader."

"And quite a hand at all athletic contests?"

"Quite a hand? My gracious! I was the champion walker, the best runner, the head man at lifting heavy weights, and as for carrying! why, I could shoulder a barrel of flour and——"

"Well, love, just please carry the baby a couple of blocks; I'm tired."

Sweepings.

A barefooted little boy stepped on a bee, and soon after said to his mother: "Ma, I didn't know that bees had splinters in their tails!"

A married woman said to her husband: "You have never taken me to the cemetery." "No, dear," replied he, "that is a pleasure I have yet in anticipation."

"Ain't that a lovely critter, Bill?" said Jerusha, as they stopped opposite the leopard's cage. "Wa'al, yes," said Bill; "but he is drefffully freckled, ain't he?"

"Waiter, I saw your thumb in this soup as you were bringing it to me!" "Oh, you're kind, I am sure, sir, but it's of no consequence. It wasn't hot enough to hurt much, sir."

They were sitting on the stoop, and as he patted her little cheek he asked, "Clarabel, what is the reason that your cheeks are so warm?" "I don't know," she answered, "unless it is that I haven't had any ice cream this evening."

A shrewd old lady cautioned her married daughter against worrying her husband too much, and concluded by saying: "My child, a man is like an egg. Kept in hot water a little while he may boil soft; but keep him there too long and he hardens."

New York millionaire—Are the girls locked up for the night wife?" "Yes." "Coachman chained?" "Yes." "Has the patent butcher catcher in the front yard been oiled so that it works well?" "Yes." "Well, we might as well chloroform the gardener and go to sleep."

Princess Beatrice—"Ma, there's a man at the door says he wants to buy Windsor Castle." Queen—"Mercy on us! Call the police. He must be a lunatic. There is not a man in England rich enough to buy Windsor Castle." Princess Beatrice—"But he is an American." Queen—"What is his business?" Princess—"He is a plumber." Queen—"Ask him in."

The other day a gentleman surprised a Boston lady who was saying to her baby, "On-ny, no-ny, e mussy tick out his little footsy tootsies." Just then she caught sight of her visitor, blushed and muttered: "No, no, you must not expose your pedal extremities by extending them beyond the protecting covering of the blanket, or you will lay your system open to attacks of catarrhal affection."

"Whar' ye bin?" he asked, as the other boy suddenly came round the corner. "To the doctor's!" "Fur yer mother?" "No—fur me." "What ails you?" "Tongue all coated—see there." "What does that mean?" "Heaps!" chuckled the other. "That means rhubarb to begin on, and loaf sugar, sweet cake, a velocipede, roller skates and a jack-knife before I get through! Don't you wish you were me?"

A gentleman and his wife, the latter with a six months' old infant in her arms, were about to enter the Austin Opera House to see the performance one night, when the doorkeeper suddenly said: "Beg pardon, ma'am, but you can't take infants inside." "Very well," said the lady, "so much the better for me. You just take care of the little fellow till the play is over—and, by the way, here's the milk bottle in case he should cry."

"Stop that car!" cried old Mr. Nosengale, chasing a flying car up the street, the car fresh as a daisy and Nosengale badly blown. "Stop that car!" he shouted, to a distant but fleet-limbed boy. "Certainly," shrieked back the obliging boy; "what shall I stop it with?" "Tell it to hold on," shouted the abandoned passenger. "Hold on to what?" yelled the boy. "Make it wait for me," puffed Nosengale. "You've got too much weight now," said the boy, "that's what's the trouble with you!" "Call the driver!" gasped the perspiring citizen, and as the car rounded the corner and passed out of sight, the mocking echo of the obliging answer came floating cheerily back—"All right! What shall I call him?"

## Foreign Gossip.

—Some idea of the difficulties in the way of making large telescopes may be had from the fact that there have been nineteen failures to cast the thirty-six inch glass for the large telescope to be mounted in California.

**THE STAFF OF LIFE.**—An extraordinary yield of wheat is recorded by Mr. Troyman, of Winchester, England, a single grain having produced 39 ears containing 2,800 grains. The three best ears had respectively 104, 103 and 101 grains.

**GOLD IN GREAT BRITAIN.**—Gold is still found in Great Britain, says an English exchange. In the year 1882, 226 ounces of the precious metal were produced from auriferous ore at a mine in Wales, the value of which at the average market price was £863.

**SALE OF ANTIQUITIES.**—At the auction sale of the collection Faw, in Paris, which was especially rich in articles of the fifteenth and sixteenth centuries, enormous prices were obtained. Among other articles of antiquity, were several German table clocks with horizontal dial and reliefs in gilt copper, which were sold at from 4,000 to 5,000 francs.

**INTERNATIONAL EXPOSITION AT NUREMBERG IN 1885.**—The Bavarian "Gewerbe-Museum" has projected an international exposition to be held in the famous old city of Nuremberg, in 1885, of gold and silversmiths' work, jewelry, bronzes and kindred articles, and, thanks to the vigorous support it is receiving on all sides, it promises to be a decided success.

**GUARD AGAINST PICKPOCKETS.**—A correspondent of the London *Times* recommends, among the many other devices suggested for baffling watch-pilfering pickpockets, a short piece of chain attached to the pendant and to the watch guard. This is at best but a clumsy contrivance, and far inferior to the turning pendant, a false pendant or collar, that encircles the true pendant and turns stiffly on it, friction tight, so that if any attempt is made to wrench the bow off, it simply slips around the pendant.

**WHIMS OF FASHION.**—The goddess of fashion, whether she be a myth or not, is at least one whose vagaries are very costly to the jewelry trade. No sooner has a manufacturer prepared some dies of long ear rings than it is decreed that short ones shall be worn. Therefore, with the best grace possible, the jeweler puts by his dies and stock of long ear rings and sets about producing some of the smaller pattern. Perhaps these have not had a very long run before an edict goes forth that only the very smallest of patterns are to be worn; and then comes the cutting of other dies and the putting aside of old ones, until eventually, when the manufacturer looks around his warehouse, he sees hundreds of dollars worth lying idle in dies that had to be discarded all through the changes of fashion.

**"TAKE YOUR BEARINGS!"**—In *Les Mondes* is described a very simple and convenient instrument, invented by Captain Bernauf, which will often be useful for sailors. When the ocean horizon is clouded, it is difficult to measure the altitude of a star. The difficulty is obviated by a circle of iron to which a small telescope is attached. Along the circle, in a groove, is placed a tube containing mercury. The metal occupies the lower part of the tube, and oscillates according to the positions which the circle takes in the hand of the observer, as it would do in the two branches of a U-tube. In every position, however, the straight line along the surfaces of the mercury in the two branches is horizontal. The observer takes the circle in his hand, directs the telescope toward the portion of the sky which he desires to explore, and when he holds the star in the field of vision, he immediately fixes the mercury in its place by touching a button which controls an ingenious mechanism. He has then only to read, on a graduated circle, the angle formed between the direction of the telescope and that of the horizontal line.

**TIMES CHANGE.**—The Hong Kong Observatory, which is to be devoted chiefly to magnetical and meteorological observations, is now in working order. It is situated opposite the city on a couple of low hills in the peninsula of Kaulung, about 300 feet from each other. The main building is 110 feet above mean sea level, and the magnetic hut is placed on the summit of the other hill. Meteorological observations are made the issue of a daily weather report, telegrams being received from Manila, Nagasaki and Wladivostock. The observatory has a mean time clock and a six foot time ball, which is stationed near the harbor and about a mile from the main building; a small transit instrument, provided with a level and a refractor on loan, has been promised by the astronomer royal of England.

—The Japanese native papers are crying out at the extinction of the lacquer industry of the country. The tree from which the lacquer is obtained is disappearing. Formerly, like the silkworm fields, it was protected by law. Each family of the upper classes was obliged to rear one hundred trees, the middle class seventy, and the lower classes forty. Since this law fell into desuetude, the cultivation of the lacquer tree has rapidly declined. The trees were cut down without care and none were planted to replace them, so that they have become exceedingly rare, while the price of the lacquer has enormously increased. Similar complaints, too, are heard of the process of disafforestation going on in Japan since the ancient law which required every one who cut down a tree to plant two in its place has been abolished.

**INTERNATIONAL EXHIBITION OF MUSIC, ETC.**—An international exhibition, devoted to inventions and music, is to be held at South Kensington, England, next year. In the division of inventions it will consist of apparatus, appliances, processes and products, invented or brought into use since 1862; and in that of music it will consist of instruments and appliances constructed or in use since 1800; of music, engraving and printing, and of historic collections. The forms of application for space must be sent in not later than the 1st of October next. For obvious reasons the "inventions" must be preferably illustrated by models, and only under exceptional circumstances can inventions be admitted which have been shown in previous exhibitions at South Kensington since 1880. Manufactured goods will not be shown unless accompanied by illustrations of the process of manufacture. No charge will be made for space, but exhibitors and their assistants will not be allowed to invite visitors to purchase goods. Motive power will be supplied free, but exhibitors will have to pay for any gas or water they may require. Properly carried out, this should be the most interesting exhibition of those held or suggested.

**REMARKABLE HISTORY OF A WATCH.**—In December, 1787, a party of fishermen engaged in fishing in the Thames, near Blackwall, caught a seawolf. They noticed that the fish appeared to be sick or on the point of dying, as it made no resistance when caught. When brought to the shore, killed and opened, a silver watch with chain, a garnet ring and shreds of gold lace were found in his stomach, and by the presence of the latter it was suspected that these articles had belonged to an officer who had fallen overboard and been devoured by the fish, which suspicion was soon found to be correct. The watch was marked within, "Henry Watson, London, No. 1369." Inquiries were instituted, and the books of Mr. Watson proved that the watch had been sold to a Mr. Thompson about two years ago; this gentleman, when called on, recognized it as one which he had presented to his son when starting on a voyage. Further inquiries also revealed that he had mysteriously disappeared from the ship during his watch. He had doubtless fallen overboard and been devoured by the fish which had feasted on the body, while the metallic portions proved too much for him. The officer had undoubtedly died with the quotation of Shakespeare, "Let me sit heavy on thy soul to-morrow."

## Workshop Notes.

**TO CLEAN FILES.**—Files may be readily cleaned of grease by holding them for a moment in a steam jet from a blow-off cock.

**SOLDERING FLUID.**—The *Scientific American* gives the following recipe for making a soldering fluid for soft soldering jewelry: Dissolve sheet zinc in muriatic acid until the acid will take up no more zinc. Turn off the clear liquid and dilute it with alcohol instead of water. When diluted with water it must retain acid enough to rust, but with alcohol the dilution can go on until the acid is not perceptible to the tongue.

**OLIVE-GREEN BRONZE.**—There are two methods for coloring brass a fine olive-green. 1. Dissolve 1 part of perchloride of iron and 2 parts of water together, and then dip the articles therein; you will get a pale or deep olive-green according to the time of immersion. Then wash, dry and brush. Or, 2. Paint the surface of the brass with a solution of iron and arsenic in nitric acid, polishing with a small quantity of lead glance, and, after heating, coat the whole with a varnish composed of 1 part varnish, 4 parts turmeric and 1 part gamboge.

**GILDING STEEL.**—Polished steel may be beautifully gilded by means of the ethereal solution of gold. Dissolve pure gold in aqua regia, evaporate gently to dryness so as to drive off the superfluous acid, re-dissolve in water and add three times its bulk in sulphuric ether. Allow to stand for twenty-four hours in a stoppered bottle, and the ethereal solution of gold will float at top. Polished steel dipped in this is at once beautifully gilded, and by tracing patterns on the surface of the metal with any kind of varnish, beautiful devices in plain metal and gilt will be produced. For other metals the electro process is best.

**COLORLESS VARNISH.**—A colorless varnish, suitable for optical instruments, prints, oil paintings and hard white wood, may be made by dissolving two and one-half ounces of shellac in a pint of rectified spirits of wine. To this, about five ounces of well burnt animal charcoal, which has recently been heated must be added, and the whole boiled for a few minutes. If, on filtering a small portion of the mixture through blotting paper it is not found to be perfectly colorless, more charcoal must be added until the desired result is obtained. When this has been achieved, the mixture is to be strained through a piece of silk and filtered through a blotting paper.

**TO SILVER GLASS.**—Dissolve 3 grains of ammoniacal nitrate of silver in 1 ounce distilled water, which solution must be rendered somewhat clouded by sufficient nitrate of silver and then filtered. Immediately before use mix 1 ounce of this solution with  $2\frac{1}{2}$  grains Rochelle salts. The glass to be silvered having been cleansed to its utmost, is placed into a suitable vessel, the bottom of which is provided with a few wax cones, thus raising the glass about one inch above the bottom, and the fluid is poured over it. The vessel is placed on the northern side of the house, or in a place with deadened light, and the silver precipitate will be sufficiently thick in two hours. It is taken out, washed and dried; if the glass with the silver pellicle is to be used as reflector or speculum, the coating must be protected by varnish.

**SOLDER FOR ALUMINUM.**—Col. Wm. Frischmuth says: The following recipes to solder aluminum have been tried by me and found practical. Take 10 parts silver, 10 parts copper, 20 parts aluminum, 60 parts tin, 30 parts zinc. The above solder is excellent for chains, etc., and can be used for the blowpipe operations. For a solder with the common soldering iron, take either 95 parts of tin, 5 parts of bismuth; or, 98 parts of tin and 2 parts of bismuth; also 99 parts of tin and 1 part of bismuth; the fuse to use in all cases is either paraffine, stearine, petrolatum, balsam copaiba, benzine. Articles so soldered must be cleaned well before soldering, and the parts to be soldered must be heated just enough to make the solder adhere to the parts to be soldered. These alloys of solders, as above stated, can be changed to suit the operator.

**GRINDING GLASSES.**—Provide two pieces of cork, one concave and one convex (which may be cut to shape after fitting to lathe). Take a copper cent or other suitable article and soft solder a screw to fit the lathe and then wax it to the cork; then get a twenty-five cent emery wheel, such as is used on sewing machines, and you have a complete outfit for cutting your watch glasses. Polish the edge on the zinc collar of the emery wheel, or use a piece of zinc to do it. The other cork should be waxed to a penny and centered. The spectacle lenses may be cut on the same emery wheel, if the wheel is attached to the lathe so as to revolve. Another method is to take a common piece of window glass (green glass is the best), and make a grindstone of that, using the flat surface to grind on. Cement it on a large chuck, the glass being from 2 to 2.5 inches in diameter.

**TO COLOR SOFT SOLDER.**—The following is a method for coloring soft solder so that when it is used for uniting brass the colors may be about the same: First prepare a saturated solution of sulphate of copper—blue stone—in water, and apply some of this on the end of a stick to the solder. On touching it then with an iron or steel wire it becomes coppered, and by repeating the experiment the deposit of copper may be made thicker and darker. To give the solder a yellow color, mix one part of a saturated solution of sulphate of zinc with two of sulphate of copper; apply this to the coppered spot and rub it with a zinc rod. The color can be still further improved by applying gilt powder and polishing. On gold jewelry or colored gold the solder is first coppered as above, then a thin coat of gum or isinglass solution is laid on and bronze powder dusted over it, making a surface which can be polished smooth and brilliant after the gum is dry.

**BRASS FINISHING BY ACIDS.**—Many articles of brass cannot readily be finished by the file or by abrading substances, owing to the intricacies of their surfaces. Especially is this true of brass castings of an ornamental character. But a most elegant finish can be obtained by means of acids, which may be protected, if desired, by means of lacquer or varnish; the acid finish, however, is generally preferred without the addition of a varnish. If the work to be finished is greasy, it should be cleaned by heating and dipping in acidulated water—vinegar and water or washing soda in water—and then in clear water. The finishing bath may be either nitric acid, two parts; water, one part; or one part sal ammoniac, one part sulphuric acid, one part nitric acid, one part water; all by measure, and the sal ammoniac to be dissolved in water until a saturated solution is obtained. The articles should not be allowed to remain in the acid more than ten seconds, then taken out, plunged into clear, cold water, then into hot soapy water, and dried in hot sawdust.

**ETCHING ON GLASS AND METAL.**—Glass is etched by means of hydrofluoric acid gas or liquid hydrofluoric acid, that is, a solution of the gas in water. The former in contact with glass produces a rough surface, as on ground glass, while the latter ordinarily leaves the surface clear. The gas is prepared by mixing together finely powdered fluor spar, calcium fluoride, three parts, and strong sulphuric acid, two parts, in a leaden dish and applying a very gentle heat. The plates to be etched may be placed over the dish. The operation should be conducted under a hood or in the open air, to avoid inhaling the pernicious fumes. The plates are prepared by cooling them while warm with wax or paraffine, through which to the surface of the glass the design is cut with suitable graving. In preparing the liquid acid, the mixture of spar and oil of vitriol is placed in a leaden or platinum retort which is heated, and the gas given off is conducted into a leaden bottle partly filled with water, which absorbs it. In contact with the flesh the acid produces stubborn sores. Metals are usually etched with dilute nitric acid, or nitre and sulphuric acid, or sulphate of copper and salt, or hydrochloric acid and chlorate of potash.



## Trade Gossip.

D. Des Mendes has just returned from Europe with a large stock of rough diamonds.

S. Dessau has just added a diamond cutting and polishing department to his diamond business.

Mr. C. A. Fowler, of Fowler Bros., was recently made the happy father of a boy. Congratulations are in order.

Albert E. Morlan, formerly of New Orleans, now United States Consul to Belire, was in the city during the past month.

J. G. Doty, formerly with Louis Strasburger & Co., has entered the employ of D. L. Van Moppes and will travel for them in future.

Mr. Addison Hubbard, of the firm of Cowell & Hubbard, of Cleveland, Ohio, recently spent several days in New York with his bride.

L. L. Schwob, of Brookhaven, Miss., recently departed from that town, leaving a goodly number of creditors to mourn his untimely departure.

F. I. Marcy & Co. have introduced this season a very attractive line of antique coin buttons with their acme lever attachment. These goods are made in sterling silver.

C. B. Burgess, a representative of the Whiting Manufacturing Co., purchased the first ticket at the new depot of the Cumberland Valley Railroad at Hagerstown, Md., October 4.

The brass band, composed of employees of the American Watch Company, entertained the good people of Waltham during the summer with open air concerts in the public parks.

Ladies' fob watchchains, in oxidized and bright silver, gold, or silver and gold combined, are about five inches long, and have a coin, ball or bell at one end. Some have a guard also.

A gentleman in Waltham has a field glass by which, on a clear day, the time given by the clock on the Providence depot in Boston can be plainly seen from the top of Prospect Hill.

Antique coin bangles, lacepins, watchfobs, etc., of oxidized silver are very popular. Many of the coins are made smooth on one side, and the monogram of the wearer engraved thereon.

D. C. Greenleaf, of Jacksonville, Florida, arrived home from Europe October 28. His partner, Mr. Crosby, met him in this city, and before going home they made liberal purchases here.

The business of the firm of J. S. Birch & Co., manufacturers of Birch's universal watch key, is to be continued under the same name, notwithstanding the recent death of the senior member of it.

Robert Nelson has removed from Dunkirk, N. Y., to Toledo, Ohio, where he has a store in the Chamber of Commerce building. He will carry on a general jobbing business in watches, tools, materials, etc.

Mr. L. B. Citroen died September 14 suddenly in Paris at the age of 43 years. He had been engaged in the diamond business in this city for twenty years and widely known and highly respected by the trade.

The annual report of the Yale College Observatory had not been made public at the hour of our going to press. Prof. Waldo writes that it has been unavoidably delayed, but will be ready in a very short time.

The Fredonia Watch Company is pushing its business with much enterprise and is selling many goods. Aikin & Lambert are the selling agents for these watches in the East, and Stein & Ellbogen have charge of the Western territory.

Stern & Stern have made special preparations for the holiday trade, and offer attractive lines of diamond jewelry, gold cases, movements, and novel and standard designs in gold jewelry of all kinds. They also carry a stock of rolled plate goods.

We have received a circular, dated at Boston, announcing that it is proposed to have an exhibition of American art products and manufactures in London, beginning in May of next year. The co-operation of leading American manufacturers is said to have been secured.

H. H. Kayton has accepted the agency for Miller's self-registering gage, for selecting or putting in cylinders, pinions, wheels, arbors, etc. It is claimed that it will save half the time ordinarily required for such work. It is a small, convenient tool, and has given satisfaction wherever used.

Bawo & Dotter announce a large stock of novelties for the holiday trade in the way of artistic pottery, plaques, bisque, parian ware, glass ware, cutlery, etc. These goods afford dealers an opportunity to diversify their stocks, making them attractive and introducing new lines.

E. R. Glover, salesman for A. Bernhard & Co., of this city, was recently taken sick at La Grange, Texas, and died at the hotel after a brief illness. He was attended by two physicians, and local dealers did all in their power for him. Mr. Glover was about twenty-five years of age, and had been a jewelry salesman for a number of years.

A spoon bowl has been patented by Mr. Henry Nickolds, Sr., of Taunton, Mass. The bowl of this spoon by this construction, instead of having a sharp edge, has its margin bent outward or extended in the manner of a flange, or made with what is styled a returned edge, so it will present a more smooth and agreeable surface to the upper lip.

Amasa Lyon, the well known manufacturer of umbrellas, parasols, etc., has a large stock of novelties in his line, embracing all the latest styles and fashions in umbrellas and parasols. He also has every variety of canes and cane heads that can be thought of. These goods are well calculated to attract custom, and are exceedingly appropriate for jewelers to carry in stock.

One Saturday noon last month an unknown man went into the office of Martin & Runyan, No. 102 Broadway, and asked to see a gold bar valued at \$500. Upon it being handed to him he dashed out of the office and ran rapidly up the steps leading from the pavement to the upper portion of the building, from whence he escaped to Pine street. The affair caused considerable excitement.

The jewelers of this city manifested much interest in the political campaign just closed, participating in various demonstrations on one side or the other. They were organized into Cleveland and Blaine clubs, the political sentiments being about equally divided. We heard of quite a number of bets being made during the excitement which is an indication that there is still some money in the jewelry business. As THE CIRCULAR is a non-partisan in politics, it hopes that all parties interested won their bets.

One of the handsomest advertisements issued this season has been got out by Fowler Bros., manufacturers of crape stone jewelry. It is a full length lithographic portrait of Christine Nielson, the famous opera singer, and is not only valuable for the richness and style of the colorings of the picture but also as a portrait of the lady. In her hand she carries a mourning handkerchief, on which appears the advertisement of the firm. The picture is a gem in its way, being both a good likeness and possessing much artistic merit.

Hodge, Slemmons & Co., of Pittsburg, have issued a very complete and comprehensive catalogue of tools, materials, optical goods and watchmakers' supplies, of all of which they carry full lines. The catalogue is profusely illustrated, showing the forms of all tools and appliances required in the watchmaking trade, styles of optical goods, watch material, etc., with prices. It is handsomely printed, and will prove an invaluable guide to persons desiring to purchase goods of this class. The firm also carry a full line of American movements, and a general stock of jewelry, clocks, silverware, etc.

A western paper tells of a watch that was lost in the fall of 1880 by a farmer while plowing. In the spring the field was harrowed and planted with corn, during the summer the corn was cultivated, and the next spring the field was again ploughed and sown with oats. That fall it was again ploughed and wheat was put in, and the next summer, while harvesting, the watch, which was lost three years before, was found in good condition. It was an open-face one and the glass was not even broken. It was wound up and it was found to run all right. The watch is still running and in good condition.

The Hanover Fire Insurance Company has issued a very handsome lithograph of the new building of the Mutual Life Insurance Company, in which the Hanover occupies conspicuous offices. The site of this building is historic ground, having been first occupied by a church in the early days of the settlement of the city and subsequently by the Post Office. It is now covered by one of the finest buildings to be found in the country. The Hanover is a prominent fire insurance company, doing a careful conservative business, and having an abundance of assets with which to meet its liabilities. It is noted for the prompt manner in which it settles its losses, and for liberality in dealing with its patrons.

At the time the Greely expedition was being fitted out, Lieutenant Greely obtained from the E. Howard Watch and Clock Company, at their Boston office, a watch for his own personal use. He selected one from their regular stock, and carried it through all his explorations and tribulations. On his return he voluntarily wrote to Mr. Albert Howard stating that the watch had given "extreme satisfaction." He says: "Three years' experience justify me in especially recommending such watches for field work in Arctic or other explorations where timepieces are subjected to remarkably rough treatment and extreme changes of temperature."

A guest of the New York hotel bought six rings, worth over \$600, from Tiffany & Co., on Thursday, and lost them on the way to the hotel. The hotel detective suspected two men of having them, and followed them into a bar room, where, over a schooner of beer and a cigar, he mentioned the missing rings. The men exchanged quick glances and retired to the rear of the room. They soon returned to Larkin and asked if he was the hotel detective. He said that he was, and added that they might as well hand over the package. After some hesitation they did so, upon the promise that he would not "give them away." They had picked it up in the street.

"Leisure Hours among the Gems," by Augustus C. Hamlin, a well known writer on precious stones, is the title of an interesting book just issued by James R. Osgood & Co. of Boston. The work is a description of some of the famous gems of the world, and contains, also, an account of various important "finds" of stones, and a general description of the character of the different varieties. The whole is written in a popular and pleasing style, containing much that is historical and much that is romantic in regard to the subject treated of. This work can be had at publishers' prices, by addressing The Jewelers' Circular Publishing Company. Price of single copies \$2.00.

Thieves entered the jewelry store of Leopold Michel at 112 Ewen street, Williamsburgh, recently, and carried away \$4,500 worth of jewelry from the show cases. Mr. Michel had a friend visiting him that evening, and he sat up somewhat later than usual. As the friend was leaving they went out to take a glass of beer, and Mr. Michel locked the shop door behind him. He believes he locked it carefully, but it is possible he shot the bolt before closing the door. Next morning the jeweler found that the shop door was ajar and the bolt of the lock was sprung as if someone had locked the door before closing it. There were no marks of forcible entry about the lock or the door. The thieves had opened a large glass showcase and had taken from it several hundred gold rings, a dozen gold watches, and two dozen silver watches, and other small articles, the whole valued at about \$4,500. In the same case they had overlooked a box containing \$2,200 worth of diamonds, a tray of gold watches, and other gold articles. They took a quantity of plated lockets and left those which were of gold. They also overlooked a much richer mine. In a corner of the shop was Mr. Michel's safe, and in it were \$12,000 worth of diamonds and jewelry. The safe doors were unlocked and could have been pulled open, as the lock was broken and it was impossible to work it. No clue to the thieves was found.

During the past month we have noticed the following jewelry merchants in this city making their fall purchases: Henry Ginder, of A. B. Griswold & Co., New Orleans, La.; James Allan, Charleston, S. C.; Mr. Thomas, of Carrington, Thomas & Co., Charleston, S. C.; M. Scoler, New Orleans, La.; Mr. Freeman, of Freeman & Crankshaw, Atlanta, Ga.; S. G. Brooks, Boston, Mass.; W. L. Kelley, New Bedford, Mass.; Edward Harris, of Harris & Shafer, Washington, D. C.; A. M. Hill, New Orleans, La.; C. L. Byrd, Memphis, Tenn.; T. G. Calvert, Lexington, Ky.; W. F. Fischer, Chatanooga, Tenn.; C. K. Giles, Chicago, Ills.; T. E. Thompson, Galveston, Texas; H. M. Ordway, Lowell, Mass.; J. M. Connell, Portsmouth, N. H.; J. E. Rood, Portsmouth, N. H.; Julian Gyot, Jefferson City, Mo.; D. R. Brown, Johnstown, N. Y.; Mr. Grant, of Brown & Grant, East Saginaw, Mich.; A. C. Wortley, Kalamazoo, Mich.; Mr. Jebb, of Jebb Bros., Jacksonville, Ills.; O. E. Curtis, Decatur, Ills.; H. A. Kingsbury, Norwich, Conn.; T. & E. Dickinson, Buffalo, N. Y.; T. H. Graham, Cleveland, O.; George Banks, of Bailey, Banks & Biddle, Phila., Pa.; Wm. G. Bailey, Helena, Montana; M. B. Wright, Kansas City, Mo.; Jacob Hammel, Syracuse, N. Y.; O. E. Zadek, Mobile, Ala.; Charles Thompson, of George R. Calhoun & Co., Nashville, Tenn.; S. L. Goldstein, Syracuse, N. Y.; L. S. Stowe, Springfield, Mass.; Mr. Hosley, of Woods & Hosley, Springfield, Mass.; E. T. Child, Hamilton, Bermuda; A. M. Bronson, Susquehanna, Pa.; G. H. Waldin, Burlington, Iowa; C. W. Carter, Norwich, Conn.; L. Braverman, San Francisco, Cal.; S. Nordlinger, Los Angeles, Cal.; A. C. Titcomb, San Francisco, Cal.

At a numerously attended meeting of the manufacturing jewelers of Providence and Attleboro, held at Providence, it was determined to organize a Jewelers' Board of Trade. This is deemed necessary in consequence of recent failures in the trade, whereby the manufacturers have been serious losers. At the preliminary meeting Mr. John A. McCloy called the meeting to order, and Mr. Dutee Wilcox was elected Chairman. Mr. McCloy was then appointed Secretary, and read the call for the meeting. Mr. Graham, of Dun's Mercantile Agency, read statistics respecting recent failures in the wholesale jewelry business, dividing them into three classes: First, honest failures; second, doubtful failures, and third, dishonest failures. Of the first, he said there were thirteen with liabilities amounting to \$745,751; of the second there were eleven with \$292,254 liabilities; of the last there were six with liabilities amounting to \$270,400. The total number of failures was thirty and the total number of liabilities \$1,308,405. The largest amount offered in compromise was 33 $\frac{1}{3}$  per cent., and the smallest 10 per cent. The following gentlemen were appointed a Committee to frame a Constitution and By-Laws, and to attend to other work necessary to the proposed organization; Mr. Dutee Wilcox, Chairman; Mr. H. Howard, Mr. George Briggs, Mr. Alfred S. Potter, of Providence, Mr. Everett Horton, Mr. S. E. Fisher, Mr. R. L. Sweet, of Attleboro. Mr. Howard read a paper containing some of his experience in the business and said that such an institution as that proposed should be founded on truth and honor. There is only one way to get this, he said, and that was by showing to men that they lose caste in the community if they misrepresent their neighbors. The Chairman of the Committee on Constitution and By-Laws reported that there was not a quorum of the committee present, so they were instructed to report at the next meeting and were empowered to engage the services of Mr. Graham as Secretary. On motion of Mr. B. W. Dodge, of the firm of Dodge, Platt & Co., the sense of the meeting was taken on the proposed permanent organization of a Board of Trade for manufacturing jewelers, and the motion was adopted unanimously. After a vote of thanks had been extended to Mr. McCloy for his efforts in behalf of the proposed organization, the meeting adjourned to Saturday, October 25.

A woman named Mrs. J. F. Heustis was arrested early in the month in Boston, on complaint of Mrs. Theresa Lynch, a dealer in diamonds, of this city. Mrs. Heustis is the widow of J. F. Heustis, who is reported to be the son of a Boston policeman and formerly a stock operator in this city. He and his wife lived in most extravagant style in this city and at Boston, patronizing the most fashionable hotels, driving elegant equipages, the lady blazing in diamonds, and she and her husband dressed in the extreme of fashion. Where the money came from to support this extravagance was a mystery to their friends. Mr. Heustis owned a beautiful country place at Marshfield, Mass., where he entertained his friends with princely hospitality. He always seemed to have plenty of money, was an occasional borrower, but paid promptly. A few months ago he died, and his widow soon after disappeared from New York, leaving many debts, of liberal amounts, unpaid. While here she formed the acquaintance with Mrs. Lynch, and seems to have been on friendly and social terms with her. It is reported that she frequently borrowed valuable diamonds of Mrs. Lynch and after wearing them would return them. In her complaint Mrs. Lynch avers that it is part of her business to loan diamonds, and claims that Mrs. Heustis represented that she was worth \$2,000,000. At different times, as set forth in the complaint, she obtained of Mrs. Lynch a diamond pin valued at \$2,000, two diamond rings worth \$900 and \$1,200, diamond ear rings worth \$1,500, a sapphire and diamond ring worth \$250, a gold watch valued at \$60, three diamond crescent pins and ear rings that cost \$1,600, a gentleman's repeating watch worth \$500, a nine-stone diamond pin worth \$2,500 and other jewelry, including a pin and ruby ring worth \$3,000. Some of this jewelry Mrs. Heustis borrowed "to show her husband." None of it did she ever return. The total amount of money held by Mrs. Heustis and belonging to Mrs. Lynch is placed at \$16,300. On this complaint Mrs. Heustis was arrested in Boston by detectives, who sought to bring her to New York, but were opposed by counsel for the prisoner. Her friends claim that Mr. Heustis was a man of property but lived beyond his means and so got into debt; that he bought the diamonds of Mrs. Lynch on credit and presented them to his wife. Mrs. Lynch will be remembered by readers of THE CIRCULAR as having figured in criminal proceedings relating to diamonds on several previous occasions. For a dealer in gems she is peculiarly unfortunate in encountering customers who get possession of her valuables without depositing their equivalent in cash. The case of Mrs. Heustis had not been disposed of as we go to press.



THE  
**JEWELERS' CIRCULAR AND HOROLOGICAL REVIEW**

*The recognized organ of the Trade, and the official representative of the Jewelers' League.*

A Monthly Journal devoted to the interests of Watchmakers, Jewelers, Silver-smiths, Electro-plate Manufacturers, and those engaged in the kindred branches of art industry.

SUBSCRIPTION:

To All Parts of the United States and Canada,  
**\$2.00 Per Annum; Postage paid.**

To Great Britain, France, Switzerland, Germany, the West Indies, Mexico, the Republics of South America, and Australia, \$3.00 per annum. Postage paid.

All communications should be addressed to SETH W. HALE, President, THE JEWELERS' CIRCULAR PUBLISHING CO., 42 Nassau Street, New York.

Advertising rates made known on application.

Congress and Commercial Interests.

AT THE TIME the November issue of THE CIRCULAR went to press, the great political parties of the country were engaged in a struggle for supremacy. The prize for which they contended was the presidency, and the administration of the government for the ensuing four years. For months politics claimed the attention of the people, and seldom has there been a presidential campaign that so interested and excited all classes as the one just terminated. During the canvass the commercial interests were made to play an important part; one of the issues much discussed—an issue upon which both parties are divided—was Free Trade vs. Protection. The discussion of this question, which promises to be a live and active one for a long time to come, served to draw our business men into an active participation in the campaign to an extent seldom equalled, and the merits of this very important subject were more fully and popularly discussed than ever before. As a manufacturing industry the jewelry trade is unquestionably large in favor of protection to our home industries, and desires a discriminating tariff that shall tax goods of foreign manufacture that enter into competition with our own industrial products; such a tariff as will enable our manufacturers to pay better wages to their workmen, and still compete with their foreign rivals in the markets of this country; also such discrimination in imposing duties as will admit free such raw material as enters into our manufactures. While our statesmen are busying themselves with schemes for extending our commerce with other nations, they should give some attention to the measures necessary to enable our manufacturers to compete in our own markets with the products of foreign cheap labor.

The November election did something more than determine the

question of presidential succession; in various districts members of Congress were chosen who will take their seats—or will be full-fledged members—on the fourth of March next. The present Congress will convene on the first of the present month, and the session will terminate with the inauguration of the new president, March 4th. As business men were so extensively drawn into an active participation in the canvass, it will be well for them to continue their interest in politics until various measures in the interests of trade and commerce are satisfactorily disposed of by Congress. The one of most vital importance is the amendments to the tariff which should be done in the interests of our productive industries. For several years this matter has been under discussion, and at each session of Congress apprehension has been felt lest something should be done prejudicial to American manufacturers—lest, in fact, the free trade element should prove strong enough to make such amendments to the tariff as would admit to the country the products of foreign cheap labor on such a basis that our manufacturers could not compete with them without cutting down the wages of their own workmen to starvation prices. So long as this agitation over the tariff is kept up, so long will it tend to check enterprise and demoralize trade. Capital is easily frightened, and nowhere is it more sensitive than when invested in manufacturing enterprises. The best interest of the commercial and manufacturing industries demand that the tariff question shall be disposed of definitely at an early day, and all the influence of our business men should be brought to bear on our representatives in Congress to secure this result.

One other thing demanded by the mercantile class is a national bankruptcy law. Last year Congress was urged to adopt such a measure, but it spent so much time in political wrangles that it failed to do so. The experience of the business community during the past year has served to strengthen the belief that a national bankruptcy law is an absolute necessity. The diverse State laws are so lax and so difficult of application that the creditor class is virtually at the mercy of swindlers and thieves, who deliberately lay their plans to obtain goods on credit, then fail, and trust to the imperfections of the State bankruptcy laws to get away with their plunder. The jewelry trade has been most seriously victimized of late by experiences of this kind. There is before Congress what is known as the Lowell bankruptcy bill; it was drafted by Judge Lowell, of Massachusetts, received the endorsement of most of the commercial exchanges of the country and of numerous trade organizations. The bill passed the Senate, and is now on the Speaker's table in the House in condition to be taken up at any time and pushed to a vote. If the commercial bodies of the country and business men in general desire this measure to become a law during the coming session of Congress, they should take steps to press it upon the attention of the House. It should be borne in mind that, allowing for the holiday recess, Congress will be in session but about two months and a half; that there will be an unusual rush of business and much political buncombe to be exploited; if anything is to be done with the bankruptcy bill the work should be commenced as soon as Congress

assembles. The various organizations in the jewelry trade should take an active part in this work, and, by pushing this bill to adoption, aid in securing some degree of protection from the swindlers who make failing a business. If there could be united action of the various organized bodies representing the interests of business men, it would have great weight with members of Congress; it would be a good thing for such organizations to appoint a committee to confer with the members from New York State and show them the importance of this measure; the committee should also go to Washington and improve every opportunity of forcing this matter upon the attention of members from other parts of the country.

The year 1883 showed a greater number of failures than any other year in our history except 1878, the total number being reported at 10,299, with aggregate liabilities amounting to \$175,968,000. This recently led the Chairman of the Special Committee of the Board of Trade and Transportation to the inference that "the majority of those who failed in 1883 were small dealers, who doubtless, in many instances, have been tempted to do so by the opportunities afforded by the exceeding loose State assignment laws, which may not be inappropriately termed, *acts to encourage frauds.*" One of the worst features of the State bankruptcy laws, and which should be specifically guarded against in any national law, is the facility afforded bankrupts for putting their property into the hands of convenient friends by making them preferred creditors. To what extent this swindle is on the increase is shown by the following exhibit of the failures of 1883 compared with those of the previous year:

|                     | Failures. | Gross Liabilities. | Actual Assets. | Specified Preferences. |
|---------------------|-----------|--------------------|----------------|------------------------|
| 1883.....           | 10,299    | \$175,968,000      | \$90,804,000   | \$9,685,568            |
| 1882..              | 7,635     | 93,238,936         | 47,469,674     | 4,919,823              |
| Excess in 1883..... | 2,664     | \$82,729,064       | \$43,334,326   | \$4,765,745            |

Here it is seen that the "preferences" in 1883 are almost double those of the year previous, demonstrating beyond dispute the increasing tendency to prefer personal friends, to the not infrequent cutting off of every *bona fide* creditor from a legitimate share in assets. The foregoing statistics do not include the amounts preferred under the guises of chattel and reality mortgages, confessed judgments, etc., given shortly prior to the assignment or failure; if these were added, the figures would reach startling proportions. The Board of Trade and Transportation, the Chamber of Commerce and other organizations of the kind have performed excellent work in exposing the glaring injustice of the system and awakening the public conscience—if we may so speak—to the fraudulent practices which are thus possible under the forms of law, and it is to be hoped the work will be unflinchingly pushed forward until success crowns their labors, and secures a national bankruptcy law based upon principles of equity. The jewelry trade should not be laggard in aiding this work.

#### How to Make Retail Stores Attractive.

THE RETAIL jewelry merchants continue to complain of the encroachments made upon their business by outside dealers—the fancy goods merchants, dry goods men, druggists, fancy bazaar keepers, etc.—who carry certain lines of jewelry which they use as a means of attracting custom and sell at low prices. We are requested to urge manufacturers and jobbers to cease selling goods to outsiders, and confine their transactions to the legitimate trade channels. THE CIRCULAR has, in the past, given much space to the discussion of this abuse that has grown up in the trade, and has pointed out its origin and suggested remedies, but we fear it has become so engrafted upon the business system that it never can be eradicated. The jewelry trade, like all other industrial and mercantile pursuits, is governed by the immutable laws of supply and demand; demand governs production, and from whatever direction

it comes, the producers will endeavor to meet it. They have their money invested in their business, and it is necessary to their financial success that they should sell their products as rapidly as possible and so keep their money turning over. It is with them precisely as it is with the retail merchants, who frequently take for their motto, "Quick sales and small profits." Business men, to whatever class they belong in trade, cannot afford to have their means tied up in dead stock; it is better to sell on a small margin of profit, re-invest and sell again, than to tie it up in goods and hold them for large profits. Indeed, we often find them selling at a sacrifice rather than carry stock that has not life enough in it to move itself. It is a fundamental principle in business to keep capital moving. To do this every good business man, be he a manufacturer, jobber or retail merchant, will sell his goods to the best customers he can find regardless of their relations to the trade. The manufacturer who has a large stock of goods on hand, is not going to hold them for jobbers in the trade to come along at their leisure and buy, when men in other lines of business are proffering him "cash on delivery" for them, and this is just what is being done in the jewelry trade. Those business men in whom the mercantile instinct is strong, have realized the fact that diversified stocks attract customers; hence the great bazaars in our large cities, where one can buy anything, from wedding rings to household furniture, including kitchen ranges, and the pots, pans and kettles necessary thereto. These men are merchants in the highest sense of the word; studying the wants of the public they aim to supply them fully; realizing the power of money they buy for cash, obtaining thereby bottom prices, and generally order large quantities, whereby they obtain the advantage of every possible discount allowed by the manufacturer; they sell for cash, realize a small profit and speedily have their funds in hand again for re-investment. Carrying a supply of almost everything the public wants, they make their stores attractive and so keep them crowded with customers. There are a dozen or more bazaars of this kind in New York, while every place of importance in the country has more or less of them. A. T. Stewart, who may be regarded as the pioneer in this class of business, was loudly condemned because, it was said, he absorbed the trade of innumerable small dealers. This was true, but he demonstrated that what might be a hardship for small dealers was his path to success. His immense fortune was accumulated because he had the true mercantile instincts largely developed, kept what the public wanted, bought for cash and sold at a small profit. It is not surprising that manufacturers and jobbers ignore trade limitations and cater to outside customers when these outsiders make it profitable for them to do so. All things being equal, they would, no doubt, prefer to sell through the trade, but as money is their object, they will supply the demand from whatever source it comes.

To meet this outside competition, retail jewelry merchants should imitate the successful merchants in other lines who are becoming their competitors. Diversify their stocks, supply the public wants and make their stores attractive. We do not mean to advise them to go into the hardware or furniture business or to handle an incongruous medley of goods, but to carry in stock those thousand and one things that are of kin to jewelry. Almost everything pertaining to art, as well as many that belong to the sciences, are appropriate adjuncts to a stock of jewelry, while many lines of ordinary merchandise can be successfully introduced. With the rage for art in all its forms that now exists, the jeweler would find a profit in carrying a line of artist supplies; these would naturally bring to him examples of drawing and painting for exhibition, adding to the attractiveness of his place of business. Very attractive goods in pottery and glassware are now to be seen everywhere, and, with the development of the pottery industry in this country, the demand for artistic examples of it is becoming widespread. To decorate china handsomely is the ambition of many ladies; why should not the jeweler afford them the materials and the facilities for doing it? Artistic stationery is also in great demand, and there is here much room for the display of taste in fine engraving and printing; as pens and

pencils constitute a part of every well selected stock of jewelry, the stationery should naturally go with it. Music is one of the sciences akin to art, and the material used in its production might well make an attractive feature in the stock of the jeweler. Musical instruments, in endless variety, are always in demand, and there is a fair profit in handling them. Of bric-à-brac there is no end, while the demand for it is so extensive that no lady is happy without various articles that come under this generic head, and "the children cry for it." In every community there are disciples of good old Isaac Walton, in whose eyes there is nothing so beautiful as a good supply of fishing tackle. Modern invention has produced some very attractive articles in this line which would prove tempting bait in a jeweler's show case. There are other varieties of sporting and athletic goods, lawn tennis, croquet, etc., which would help to introduce custom and add attractiveness to the store of the merchant.

We might continue this list indefinitely, mentioning many varieties of goods that would be entirely appropriate in a jewelry store, and that would tend to attract custom, but it is unnecessary. What we desire to convey is the idea that retail merchants should appropriate a leaf from the experience of others, and, by offering the public the means for supplying a fair share of its multifarious wants, attract to themselves a more liberal portion of its patronage. With a good stock of carefully selected jewelry on hand, they have laid the foundation on which to build up a business that shall include the sale of all kinds of goods that appeal, directly or indirectly, to the artistic tastes of the community in which they live. Let them make art bazaars of their business places, avoiding the incongruities that are to be found in the other class of bazaars we have alluded to, and provide a display of fine goods that shall appeal to the eye and gratify a taste for the beautiful. By this means they direct attention to their stock of jewelry, and will not need to fear competition from outsiders. Times have changed greatly in the past few years, and business methods have changed with them. Trade no longer flows through the channels prescribed for it by tradition, but, like the Mississippi river, breaks down all barriers and flows wherever it finds a convenient outlet. Those who would benefit by it must be prepared to take advantage of every change, and to conform their habits and practices to the new order of things. The manufacturer must produce what the public wants, and supply the demand through such agencies as he finds at hand, while he who seeks to live by buying and selling must cultivate his mercantile instincts to the highest degree and be prepared to meet competition on its own ground. We do not say that the new methods of doing business are better than the traditional ones that recognized the manufacturers, jobbers and retail merchants as three distinct classes, each having rights the others were bound to respect, we simply look at the situation as it exists to-day and speak accordingly. No one class is more responsible than another for the breaking down of trade barriers; this is due to increased competition solely in all branches of the trade; a competition that has forced it to broaden out and extend itself in such directions as it could find outlets.

---

### National Exhibitions.

THERE ARE in progress now, or are announced for the coming year, several exhibitions which, from the magnificent proportions of the preparations, are deemed worthy of being called national. The one now in progress at New Orleans is the outgrowth of an effort made several years ago to improve the cotton culture of this country. It was a fact lamented by political economists, that much ignorance prevailed among cotton growers as to the best methods of preparing their product for the market, and that, consequently, it deteriorated from twenty to fifty per cent. between the time it was picked and its advent in the factories where it was manufactured into various fabrics. It was thought a desirable thing to get up an exhibition whereat could be exhibited the improved machinery invented for handling cotton in its various stages, show the best

methods of handling and storing it, and, in fact, to bring producers, inventors and consumers together, where each could learn from the other something regarding the requirements of each. The scheme was a brilliant one, was successfully carried out and has already brought forth good fruit. What was originally designated a cotton exhibition, is now termed a "World's Industrial Exposition," or something similar, and appeals not only to the industries of this country but of other nations, to come forward and compare notes of progress made and results achieved. In two or three European countries similar exhibitions are proposed for next year, and the present outlook for their success is quite promising.

To what extent the gold and silversmiths' art, the watch and clock-making sciences, and the many other special industries in the jewelry business, will avail themselves of these opportunities to show the world what they are doing, we have no intimation; but, for the general welfare of the business, we trust they will make their best exhibits and attend them largely. We are thorough believers in the practical utility of these national and international industrial congresses. The Philadelphia exhibition of 1876 did more to stimulate invention and to encourage workmen than anything that has ever taken place in this country. It was a museum of natural and industrial curiosities, an art school and a grand international workshop combined. It is still referred to as one of the greatest events this country has ever witnessed, and the many thousands of persons who visited it still refer with pride and satisfaction to what they saw at the Philadelphia exhibition. Crowds of workmen in various callings attended to study their specialties, often being sent long distances at the expense of their employers. It was the grandest recognition of the achievements and power of labor that was ever made, and did more to educate our workmen and stimulate them to renewed efforts than would have come to them from years of hard plodding at the work bench or in the factory. The arts employed in the jewelry trade never appeared to better advantage than at the Philadelphia exhibition, and it was a proud day for our horologists, our watch-makers, gold and silversmiths, and our manufacturers of jewelry, when they could stand side by side with the workmen of Europe and show to the world that, while this nation is young in art work by comparison, it was equal to a comparative competition with those nations where the arts were old when our nation was born. That exhibition served to teach our own people that it was not necessary to go abroad when they wanted fine examples of work in the precious metals, and that the taste of our manufacturers in producing articles for personal adornment were far in advance of those of their European brethren. It would be a grand thing for the jewelry trade if there was a permanent exhibition of this kind in this country; it would serve the purpose, to a great extent, of an art school, and prove a valuable aid in developing our young workmen into artists in metal work.

But there is no permanent exhibition and no art school; in their absence the trade should take advantage of every opportunity offered to exhibit the products of their workshops, and thus sustain the good impression formed by the people at the Philadelphia exhibition. It is not always possible to get a competitive exhibition with European manufacturers, but it is a good thing to show our people what we ourselves are doing and the progress we are making in the arts and sciences. It will serve not only as a stimulus to better efforts on the part of artists and workmen, but will have a tendency to improve trade and put money in circulation. Why is it not feasible and desirable to have a gold and silversmiths' exhibition in this city every year?

---

### The Holiday Trade.

THE HOLIDAY trade has been better thus far than could reasonably have been expected earlier in the season. During the latter part of October there was a noticeable improvement in the

volume of business transacted, and during November it continued to swell until it became fairly brisk. From the expression of the buyers who were in the city, it is evident that a fair amount of business is anticipated by the retail trade to close the year. There is a better feeling pervading the business men in the rural districts; farmers have generally marketed their crops, and while they were somewhat disappointed as to the prices obtained, they nevertheless realized a fair profit, and were satisfied to put in circulation the money they received. Retail dealers have felt justified in ordering more liberally than they contemplated doing, and thus the jobbers' orders are more extensive than they promised to be. It may be said that business was fairly active during November, with a promise of its continuing so throughout the present month at least. Then comes, in the natural course of trade, a lull till spring, which time is taken advantage of by the houses in the trade to make up their books, take account of stock and get ready for the business of next year.

The temptation to buy holiday goods has been unusually great this year, for the prevalence of attractive and desirable goods, combining utility, novelty and excellent workmanship, has been universal. New designs in almost every class of goods is the rule; the public demands novelty, and the manufacturers meet them squarely and satisfactorily on that issue. Their artists and designers are kept busily at work all the time, and there is scarcely an article known to the trade that has not this year appeared in some new form, or that is not made novel by a new style of ornamentation. The most critical artistic taste is satisfied with the results, while to the uncritical eye the work seems perfection. In gold and silverware the number, variety and elegance of the articles offered has never been equalled, and in gold goods for personal ornaments, the forms, devices and styles defy enumeration, while for attractiveness they leave nothing to be desired. In diamond jewelry the variety of settings is endless, running from the very elaborate to severe plainness. In gems there can scarcely be said to be any fashion; once possessed of the gems themselves the owner can exercise his or her own taste as regards the form or style of setting. Yet many improvements have been made in these of late, all, of course, designed to show the gems to the best advantage. In every line of goods there is exhibited a spirit of progress, and each new article as it comes from the factory possesses attractions peculiarly its own. If, therefore, the holiday trade is not voluminous and profitable it will not be the fault of the manufacturers, for never before have they appeared with so tempting a display of goods. Up to the present writing the trade has been quite as good as was expected, and the outlook is promising for the present month.

---

## Gossip of the Month.

---

HAVING surreptitiously caught a glimpse of the editor's proofs this gossip observes that he asks, in another column of THE CIRCULAR, why it is not feasible and desirable to have an annual exhibition of the products of our gold and silversmiths, horologists, manufacturing jewelers, etc., embracing all those goods handled by the jewelry trade. As to the desirability of such an exhibition there can be no doubt, but on the question of practicability there will be variety of opinions. That the trade could make a most attractive exhibition, contributing thereby greatly to art study, and to stimulating artists and designers to more original and better work, cannot be denied; but will they do it? In answer to this steps in the selfishness of the individual, and he can see nothing beyond the present outlay; the dollar of immediate expense blinds him to prospective thousands. The individual argues: "I pay large rent for my show room, there all my goods can be seen at all times by whoever calls; why should I contribute of these to make an exhibition whereby my competitors will profit as much or more than I can; here I have a

permanent exhibition, and it is to this immediate spot that I desire to attract the public." This is arguing from a purely selfish and shortsighted standpoint. Thousands of persons will visit an exhibition where the combined products of many manufacturers can all be seen at once, who would not take the time to visit the many places of business of the individual manufacturers. Being at the exhibition, and being delighted with its magnitude and with the magnificence of its artistic exhibits, they would be tempted to buy liberally then and there; a lively interest in this branch of manufactures would also be excited, and they would be on the lookout for future developments. Such an exhibition, under proper management, would attract many thousands of visitors, could be made self-sustaining and would be the grandest showing of the progress made in the arts of metal working that could be devised. The annual exhibition of the American Institute has been of immense advantage to the hundreds of persons who take part therein each year, evidence of which is found in the number that exhibit and the many thousands of persons who go to see this heterogeneous collection of articles of use and value, comparatively few of which, however, appeal to the sense that admires that which is beautiful; every exhibition of paintings is largely attended, and it is conceded that they are necessary to the cultivation of the artistic perceptions of our people and to the success of the artists. Such a magnificent exhibition as could be made annually by the jewelry trade would command an attendance equal to those alluded to, and would serve, also, as an art school for both the general public and those within the trade. If the selfish interest of individuals will give way to a desire to promote the general welfare of the trade, such an exhibition annually of trade products would not only be feasible but highly beneficial, serving to stimulate a more active demand for goods, and to increase the public estimation of those industries that are capable of producing such artistic work.

\* \*

\* \*

\* \*

THE story is told of a young husband going home to his wife, wearing a careworn, discouraged look, and saying to her in doleful tones: "Julia, my dear, we are ruined." "Ruined, my love, what do you mean?" queried the sympathetic partner of all his joys and as few of his sorrows as possible. "I mean that I am ruined—can't pay my debts—have failed—am busted wide open." "Oh! George! how you frightened me—I thought something dreadful had happened," said his affectionate spouse. "But I'm so glad you have failed, George. That's just what I've been praying for." "Glad of it!" says George. "Glad I am ruined! Oh! you unfeeling woman!" "Of course I'm glad, George, for I'm sure you've made me a preferred creditor for \$100,000 or so, and now we can go to Europe and enjoy ourselves!" So wags the world. The preferred creditor dodge has enabled many a man to live in luxurious ease, snapping his fingers at those creditors whose claims against his estate were honest and legitimate. It seems as though we had heard of transactions, savoring of the nature of the above, in the jewelry trade, but perhaps we are mistaken. Anyhow, a reasonable and equitable national bankruptcy law would prevent any such occurrences in the future.

\* \*

\* \*

\* \*

THERE is room for the display of much artistic taste in displaying goods attractively and making them show for their full value. We have seen the show windows of some jewelers that were about as attractive as the windows of a junk shop; there were goods enough—too many, in fact—of excellent quality, but they had the appearance of having been pitched into the window with a barn shovel. No attempt was made at artistic arrangement, nothing done to attract attention to the merits of each particular article, but silverware,

watches, chains, bracelets, diamond goods and rolled plate all mixed in together, higglety-pigglety, on a foundation of pine boards covered with an old newspaper. Similar disorder characterized the show cases in the store, the glass of which was smouched and cracked and the metal work discolored and dirty. Dirt and disorder were in evidence everywhere, and the proprietor sat at his bench smoking an old foul pipe wondering why people did not come in to buy goods. The public was treating him with the same indifference with which he treated them—he took no pains to attract their attention and they were not attracted. In some of the large dry goods and fancy stores of this city men are employed at large salaries to “dress” the stores; they have the eyes of artists, and the good taste to so arrange the goods selected for display as to exhibit them to the best advantage, while each contributes something to creating a harmonious exhibit; the general effect—the *tout ensemble*—is pleasing to the eye and attracts customers. This last is the objective point; if the artistic display once induces a person to enter the store, the ingenuity of the salesman is relied upon to make him a customer. Some of the most attractive show windows in New York belong to the jewelers. They are kept supplied with fresh goods, frequent changes being made, and whatever is new and attractive is exhibited in such manner as to set off its beauties to the best advantage. There is seldom an over display, but the idea is to put forward a few things attractively. Fine goods, diamonds and other gems, are arranged on a back ground of dark velvet; draperies are frequently hung in the windows upon which various goods are displayed; vases, bisque figures, ornamental clocks, statuettes, examples of artistic pottery, are displayed frequently to give a finished setting to the jewelry and command attention. Crowds gather about these show windows, and during all the busy hours of the day, there is a constantly changing throng of curious persons gazing upon the varied attractions of the show windows. Many are induced to enter the store, and, finding the same desire to interest them displayed, they become purchasers. The public is a peculiar and sensitive creature; to get into his good graces he must be approached in a pleasant and agreeable manner, while he who would win favors from his majesty must cater to all his wants, peculiarities and eccentricities. The very best way to appeal to the public is through its universal appetite; the next best is to charm the eye; fascinate it with that which is beautiful and desirable and the way to the multitudinous pocketbook is materially shortened. There are art, skill and science in properly “dressing” a show window.

\* \*

\* \*

\* \*

THE Goddess of Fashion having decreed, as we have previously stated, that gold jewelry, as well as precious stones, may be worn by her votaries, a new impetus has been given to the production of stylish designs. Manufacturers vie with each other in making goods in endless variety, calculated to suit the varying taste of the public, and to satisfy the most fastidious critic. Never before were gold goods so attractive or so well adapted to the captivation of the feminine eye. It has long been a recognized fact in every well regulated newspaper office that a lady is the only competent person to write about fashions for ladies. In accordance with this idea we have engaged the services of a lady who is a well known fashion writer for the daily press, to furnish us with an article each month describing “Fashions in Jewelry.” She will visit the various houses in the trade from time to time for the purpose of ascertaining what new goods are being made to supply the demands of fashion. Her first contribution will be found in this issue, and a perusal of it will indicate to the retail trade some of the many styles of jewelry that are prized by the ladies of this vicinity. It is a matter of accident almost when the average fashion writer makes any allusion to jewelry, or to the new styles that are being constantly brought out at so much expenditure of time and money. They sometimes describe a party

costume or a wedding toilette, wherein various gems form a conspicuous feature, but they entirely omit to mention the styles of jewelry worn by ladies in their every day costumes, in the street, at home or at ordinary receptions. Now, every lady must have more or less jewelry for her ordinary every day adornment, and as there is the greatest latitude for selection among the endless productions of our manufacturers, it will be the purpose of our fashion writer to point out the beauties of the various articles to be found in this city, the head center of the jewelry trade, for the information and benefit of the ladies in particular and the retail trade in general. This new feature of THE CIRCULAR will be an important one to the trade, for we intend it to be so thorough that it will furnish the material for the fashion notes of most of the papers of the country, and fill a want in fashion intelligence that has never before been attempted. As the lady in charge of this department will call upon members of the trade from time to time, duly accredited from this office, any courtesies shown her will be appreciated by us.

\* \*

\* \*

\* \*

DURING the political canvass just ended, each party promised that, in the event of its being successful, there would be an immediate “business boom” that would bring prosperity to every one. Well, the contest is ended, the result is known, and we are all ready for the booming to begin. For the last month of the canvass business was almost suspended, and men, women and children became politicians for the time being, to the neglect of their legitimate occupations. Never before have we seen the jewelry trade so given over to the discussion of politics; but it was in the air, like an epidemic, and there was no escape from it. It is fortunate for the country that such political cyclones, so disastrous to business of all kinds, come but once in four years; it would be better if it was once in ten years. But now that the election is over, it is in order for every one to settle down to business, and so each in his own way contribute to the extent of his ability to the redemption of the party pledges. All that is wanted is a unanimous determination that times shall be better and they will be. The country is in a condition to command prosperity; our national affairs are in good shape; our granaries are filled with the abundance of the year's harvests; money is plentiful and eager for investment; all that is wanted is confidence in the future on the part of one and all. With our resources, business should be active, and we should be the most prosperous nation on earth, especially as we have been going through a period of liquidation that has squeezed the water out of all speculations and brought us to a basis of hard pan values. The election is behind us, and for the next four years, at least, we can devote ourselves to business exclusively. As Gen. Grant said to Gen. Sheridan just as they were getting out of the Wilderness, “Now is the time to push things.”

\* \*

\* \*

\* \*

WE FIND in a San Francisco paper the statement that in February last, the Mexican Government granted to a native company a concession for sixteen years to fish for pearls from Cape St. Lucas to the Colorado River. This concession was transferred last July to a San Francisco company, composed of one Mexican, Juan Hidalgo, and four Americans, G. W. Waltz, D. Samuels, R. E. Phillips and J. Jacobs. All are wealthy business men. They pay a royalty of \$10 a ton on pearl shells for three years, and \$15 for the remainder of the time. From pearls alone their revenue is estimated at a quarter of a million, and from shells \$150,000 a year. They also have power to arrest any one poaching on their preserves. We are not in favor generally of creating monopolies, but the pearl fisheries of the Mexican coast are likely to be more thoroughly worked by American enterprise than by the constitutionally tired Mexicans. If the new

arrangement succeeds in making pearls more plentiful, the jewelry trade will not complain even if a few American citizens do make money in the operation.

\*  
\*\*\*  
\*\*\*  
\*\*

AN arrangement of an important nature to foreign inventors and patentees has lately been entered into by the governments of Great Britain, France, Italy, Belgium, Spain, Holland, Portugal, Switzerland, Servia, Brazil, Guatemala, San Salvador, Ecuador and Tunis, for the formation of an "International Union for the Protection of Industrial Property," under the rules of which "the subjects or citizens of each of the contracting States shall enjoy, in all the other States of the Union, in everything that concerns patents for inventions, designs, models and trade marks, the same advantages that the law of these States accords to their own citizens, including the same protection, and the same legal remedy against persons infringing their rights, on the sole condition of submitting to the formalities and regulations which each State imposes on its own citizens." It was also made a part of the treaty that commercial names shall be protected in all States belonging to the Union, to the extent of seizing any goods imported into any of them under the counterfeited name of an established firm. An International Bureau is to be established under the protection of the Swiss Government, which will have general supervision of the management of industrial property, and is to collect and publish statistics, and answer questions submitted to it. Besides this International Bureau, each of the treaty States will establish a local Administration, which is to gather information for transmission to the central Bureau, and is to publish a periodical account of matters relating to the subject in each country. It is a matter of surprise that the United States Government, which is usually foremost in proposing international treaties, was not a party to the one referred to. As a consequence, inventors acquiring patents in this country, will not be permitted to share the advantages conferred by this union, but will be subject to all the patent laws of the different nations as heretofore. Perhaps the new administration will make application to be counted in on this Industrial Union scheme, but it is unfortunate that the government was not present by deputy to have a voice in the preliminary arrangements.

\*  
\*\*\*  
\*\*\*  
\*\*

It is wonderful what an endless variety there is in clocks, and also how low the price is for reliable timekeepers. For the matter of that, however, one can pay as high a price as he chooses for a clock and still get the worth of his money, for they come in all styles of "architecture," in all sorts of shapes, of all sizes, and ornamented in every possible style of decoration. There is a vast amount of capital invested in this country in the clock making industry, and nowhere are so many clocks used by the people. Our people are not satisfied unless they have a clock in nearly every room in the house—upstairs, down-stairs, and a particularly elegant one in my lady's chamber. There are parlor clocks, hall clocks, dining room clocks, boudoir clocks, chamber clocks, cuckoo clocks, grandfather clocks, carriage clocks, alarm clocks, kitchen clocks, and, we suppose, clocks for the cellar and clocks for the coal hole. However this may be, from the endless variety offered, embracing novelty of construction, elegance of material and workmanship, together with perfection as timekeepers, the intending purchaser cannot fail to be satisfied, whether he wishes a gorgeous and useful present for a bride or an alarm to waken the servant in time for breakfast. Clocks have taken on many artistic and fanciful forms especially for holiday presents, small movements being smuggled into designs where their presence would never be suspected but for the dial or the hands that point them out. Ornamental frames in plush or decorated by hand paint-

ing make fanciful clocks for odd places in interior decoration of houses, and constitute surprises when one comes upon them unexpectedly in stray nooks or corners. A vast amount of ingenuity, artistic and mechanical, is expended in getting up these novel designs, but in doing so successfully the manufacturers contrive to keep fully abreast of the times, and to contribute their share towards making this a progressive age.

\*  
\*\*\*  
\*\*\*  
\*\*

THE prime meridian conference that assembled in Washington Oct. 1, consisted of forty members representing twenty-four different governments, as follows: Austria-Hungary, Brazil, Colombia, Costa Rica, Denmark, France, Germany, Great Britain, Guatemala, Hawaii, Italy, Japan, Mexico, Netherlands, Paraguay, Russia, San Domingo, San Salvador, Spain, Sweden and Norway, Switzerland, Turkey, Venezuela and the United States. The conference was not as prompt to adopt the general meridian of Greenwich as had been expected, but a resolution to that effect was finally passed, and that meridian recommended to all governments for adoption, the representatives of twenty-one governments voting in favor of it, San Domingo against it, and France and Brazil abstaining from voting. The conference also resolved that longitude continue to be counted as at present in two directions, up to 180°, instead of in one direction up to 360°, as had been recommended by the Roman conference. Although the Greenwich meridian has long been the standard for four-fifths of the world's navigators and geographers, its adoption by all will be a common benefit. The ancient geographers drew the first meridian through Ferro, the westernmost of the Canary Islands, and this is yet followed to some extent. The French have also used the meridian of Paris, the Spaniards that of Madrid, while we have used both that of Greenwich and Washington.

\*  
\*\*\*  
\*\*\*  
\*\*

THE trade is constantly being victimized in various parts of the country by ingenious swindlers, who apparently sit up nights to devise new methods for overreaching the guileless and unsuspecting jeweler. The "tricks and the manners" of these swindlers are as varied as the individuals who perpetrate them. One of these most successful methods has been the bogus check dodge, the accomplished perpetrator first gaining the confidence of the dealer by representing himself as connected with some well known business house in good standing, writing to him on the letter heads of such house, and finally paying for the goods he orders with a check bearing the name of the house. It takes several days to lead up to this swindle, during which time the operator is winning the confidence of the dealer, and finally gets away with some valuable article of jewelry and a balance in cash between the value of the goods and the amount for which the bogus check is filled out. Another method is to send a messenger to the jeweler, asking that certain goods be sent to the house of some well known citizen from which a selection is to be made; the package is left as directed, when along comes the swindler and says the goods have been left by mistake, gets the package and makes off with it. These tricks have been played quite frequently of late, and with a degree of success that must be flattering to the swindlers. The only consolation the jewelers can have lies in the fact that merchants in other lines have been swindled in a similar manner. While it is true that "misery loves company," the fact that another has been robbed will not bring back the lost goods. Jewelers are particularly sought out by confidence men as victims, for the reason that the goods in which they deal make small packages, are easily got away with and are readily converted into cash. The old rule of law that every man is supposed to be innocent until he is proved guilty, ought to be reversed when a stranger enters a jewelry store. It is well to exercise the greatest degree of caution, and either



confine all transactions with strangers to a purely cash basis, or else require every individual to bring the strongest kind of credentials. No honest man will take offense at being required to identify himself, and if a stranger objects to doing so, that is an additional reason for suspecting him. A merchant should be as careful in letting goods go out of his possession as he would about trusting so much cash to another, yet many, fearing lest they should lose a sale, entrust hundreds of dollars worth of goods to men whom they would not loan five dollars under any consideration—to absolute strangers, in fact. This lack of caution and ordinary business prudence has cost the jewelry trade a vast amount of money. More danger is to be apprehended from the confidence men—the smooth, suave, pleasant spoken, well dressed stranger—than from the professional thief or burglar; one class can be provided against, but the man who is so frank and open in his address throws his intended victim off his guard at once. The trade would do well to devote a little more time to developing its bump of caution.

\* \*

\* \*

\* \*

QUITE a number of prominent dealers in this city have resolutely set their faces against that unbusinesslike and pernicious practice of dating bills ahead, thereby giving six months credit for a four months note. There never was any excuse for this practice obtaining a foothold in the trade; it was introduced first as a special accommodation to retail merchants, and as an inducement to them to buy goods more liberally, but finally became a recognized custom with some which the retail dealers were quick to take advantage of and insist upon. It only requires united effort on the part of a few of the more prominent houses to entirely do away with this evil which has no place in legitimate business, but is a positive injury to both buyer and seller. The retail trade can no longer count on this extra accommodation; instead they will be generally required to pay extra for extra long credit. Special discounts will be given them as an inducement to pay promptly, such discounts being less as the time of payment is extended. But the buyer who comes with cash in hand is the one who will get the greatest advantage in the trade, and is precisely the man all are looking for. The merchant who can place all his transactions on a cash basis will find that he has greatly increased his margin of profit.

\* \*

\* \*

\* \*

THE annual banquet of the Jewelers' Association, that took place at Delmonico's on the evening of November 13, was one of those enjoyable social events that occur in the trade but too seldom. There was a good dinner to satisfy the inner man, good wine to warm the cockles of his heart, good speeches to tickle his ear and excite his risibilities, and a good cigar to aid his digestion and sharpen his appreciation of the other blessings. Under such cheering and inspiring conditions the most frigid nature could not help but thaw and glow with genial warmth, responding heartily to the spirit of fraternization and brotherly regard that pervaded the atmosphere. Such social re-unions tend to soften the asperities of business competition, to smooth the pathway of our active, pushing lives, to broaden one's views and enlarge his humanity. "All work and no play makes Jack a dull boy;" the same rule applied to business men is apt to make them crusty, nervous, irritable and otherwise objectionable. The trouble with all our business men is that they take life too seriously, and give too little time to relaxation. Such events as the annual banquet of the Jewelers' Association are, therefore, to be hailed with delight, as affording each participant an opportunity to lay off his business mask and stand revealed before his fellows as a good-natured, whole-souled, sociable atom of humanity whom it is good to know. The banquet, like all its predecessors, was a most enjoyable

one, and in every way creditable to the Association and its guests, which means that the committee of arrangements did its work in a manner deserving of high commendation.

\* \*

\* \*

\* \*

WE ARE glad to learn that the memorandum nuisance is abating somewhat. As THE CIRCULAR has repeatedly in times past shown how burdensome to the jobbers and manufacturers is the practice of retail dealers demanding to have goods sent them on memorandum, we feel justified in claiming some credit for having contributed to reducing the magnitude of this evil. It is by no means entirely done away with—the custom is only scotched, not killed—but the demand for goods on memorandum is reported as being very much less than it was two years ago. While the jobbers are ready to do everything reasonable to promote the welfare of the retail merchants, the latter should exercise judgment and some degree of modesty when seeking favors. To respond to the unlimited demand formerly made upon the jobbers for goods on memorandum required them to keep on hand a large and unnecessary stock of goods, thus tying up capital that should have been employed in other directions. The return of most of these goods, insecurely packed and in a more or less damaged condition, was a matter that inflicted much needless expense upon the jobbers and manufacturers. Retail merchants are, at times, justified in requesting to have goods sent them on memorandum, but when they do so, they should, if unsold, return them promptly (charges paid), and see that they reach their owner in as good condition as they were when he loaned them. By the exercise of a little consideration in this matter, and seeking to make a practical application of the golden rule to each transaction, the retail dealers can reduce the proportions of the goods-on-memorandum evil to such an extent that it will no longer be a burden upon the jobbers and manufacturers.

\* \*

\* \*

\* \*

TRADE became quite active immediately after the election excitement was over, and our city merchants wore smiling countenances once again. In response to the universal inquiry, "how's trade?" came the invariable answer, "it's improving; nothing to complain of now." Coming down to particulars, the general report was that a good many buyers were in the city during the latter part of last month who ordered goods with a fair degree of liberality, while orders by mail contributed to make business fairly active. Before the election merchants in all lines acted as though they really put faith in the political buncombe belched forth by stump orators to the effect that if their opponents were successful the country would immediately go to everlasting smash and business be destroyed beyond the possibility of redemption. The funny part of it was that these assertions were made with the utmost gravity by Democrats and Republicans alike, and with such a degree of earnestness that it really seemed as though they believed them and expected others to. These blatant pothouse statesmen evidently forgot that there are nearly sixty millions of people in this country, all of them engaged in some kind of business, and that they are not made of that kind of stuff that would stand idly by and see their prospects ruined or the stability of our government threatened to please any little clique of politicians. The country has gone through perils to which the election of a president is but a flea-bite, and came out of them in good shape, improved financially and materially. This country is pretty securely anchored fore and aft, and it is not in the power of any captain to drive it from its moorings or imperil its safety. Those sixty million of people are going to have something to say when there are breakers ahead. But the atmosphere is clearer since the polls closed, and those who listened to such rambling talk have settled quietly back to their daily avocations, intent upon doing their share

towards "booming business," regardless of their ante-election party predilections. The holidays are upon us, and it is time every dealer had his stock in hand prepared to take advantage of the demand that always comes at this season. During the two weeks just passed more goods were sold than in the preceding two months, and dealers generally are well stocked for the holidays. Those who have postponed their orders should not delay longer; they have missed something already by not having the first pick of the holiday goods, but it is not too late to remedy the neglect if they now hurry forward their orders.

\*  
\* \*\*  
\* \*\*  
\* \*

THAT very useful and enterprising and altogether indispensable individual, the commercial traveler, appears to have fallen on hard lines in some of the Southern States, especially in Texas, where, as we are informed by the local papers, he is regarded as an elegant but expensive luxury. We own our inability to conceive how any enterprising merchant can justify this sentiment regarding the commercial traveler, in view of his position in its various relations to modern methods of transacting business. However that may be, the *Galveston News* states that "the leading wholesale houses of that city are withdrawing from service the greater portion of their traveling force, reducing expenses somewhat difficult to be borne in these times of business stringency." That journal also advocates doing away altogether with the travelers, alleging that they are far too expensive, eating up all the profits of trade, while the system itself is deprecated as "the outgrowth of ill-directed competition." Due notice is given that the merchants of Galveston "have definitely decided to do away with the drummer system, and will not in future compete for trade in this way." We predict, then, that the merchants of Galveston will find a material falling off in the volume of their trade, and that their more enterprising neighbors will reap the benefit of their apathy. The *New Orleans Times-Democrat*, in fact, says that the merchants of that city are not prepared to follow this example. The experience of New Orleans in the matter is thus stated: "This city found, some years ago, that its trade was suffering greatly from the invasion of the territory commercially belonging to it by drummers from Chicago, St. Louis and other points; and it saw the necessity of adopting the system for its protection. It has managed through it to secure considerable business in Texas of late years, and it is likely to do better than ever in that State if the merchants of Galveston and other towns cease to send out a traveling force." In these days of hurry and bustle, the commercial traveler is a power and an influence that cannot be ignored. He is a personal appeal, a substantial entity, to the retail trade, going out from the jobbers laden with examples of all that is choice, attractive and desirable in their stocks; he lays them down to the retail dealer without subjecting him to the loss of time or the expense that would be necessary if he went to hunt up the goods himself. He is, also, the medium of communication between the different classes in the trade, an encyclopædia of useful information, and a standard authority on styles, fashions, designs, etc. He is a living reality, capable of presenting, with eloquent tongue, the merits of the goods he exhibits. He is a walking advertisement, a peripatetic descriptive circular, having the advantage over printed ones that he cannot be readily thrown into the waste basket before imparting the information with which he is loaded. Under modern methods of doing business the commercial traveler cannot be ignored or safely dispensed with.

---

### Swiss Wood Carving.

THE LONDON *Times*, in a letter from one of its correspondents, referring to the removal of a number of Swiss carvers to the United States, says that they earn as much as eight dollars a day

—more than they can earn at home in a week. This turned into francs sounds a good deal, and is, indeed, an undeniably high wage, eight dollars a day being nearly 10 pounds a week, only a little less, says the writer, than the salary of the President of the Confederation. For all that, the *Berner Post* and other papers of the district are strongly of opinion that the wood carvers would do much better to stay at home. They say: "Do not be so selfish as to follow the example of the horologists of the Jura, and establish in America a new trade which will compete with one of our most important local industries. In the United States you will be far away from your native mountains, from the scenes which suggest and the objects which inspire. The only works of art you will see are statues of Washington and Lafayette, and though you may earn more money you will not be half as happy as you are at Brienz, and Meyringen and Interlaken. Stay at home, and instead of going to America let the Americans come to you and buy your chalets, your bears and your chamois, in the land where they are made."

How far these persuasions will be effective remains to be seen, but it is greatly to be feared that the inducement of 40 francs a day may prove more potent. On the other hand, the attachment of the Swiss to their homes has passed into a proverb; and although some of the watchmakers of the Jura have gone to America, the deftest of them, those who live in the valley of Lake Joux, resolutely refuse to leave their native mountains and abandon their traditional habits for all the inducements that foreign capital can offer.

Swiss wood carving is a much younger industry than Swiss watchmaking. It was introduced into the Bernese Oberland some fifty years ago by Christian Fischer, a self-taught peasant artist of Brienz. But he was more peasant than artist, detested working indoors, and his ambition did not extend beyond carving rings for table napkins, cutting wooden egg cups and adorning them with flowers. He was also a musician and village bone setter, and altogether a man of versatile genius. But his great merit was being the creator of a new industry, for though Fischer did no great doings himself, he put into practice a valuable idea and founded a school. Peter Baumann, of Grindelwald, and a man named Flenz belonging to the same country, improving on Fischer's idea, began the making of those charming Swiss chalets now so popular, and which it is now almost *de rigueur* for tourists in Switzerland to purchase. What was more natural than for these peasant artists to model, first of all their own picturesque houses with their overhanging roofs, their quaint galleries, their painted ornaments and carved figures brown with age, standing on a plinth of white stone, overshadowed with trees, within sound of a rushing torrent, and sheltered from avalanches and the north wind by the rocky rampart of some Alpine height?

Peter Baumann, who seems to have been more thrifty and steadfast than his predecessor, settled at Meyringen and taught his art to his three sons, one of whom, Andreas, became the *facile princeps* of wood carving. His work is deemed unapproachable, and his bouquets of roses still serve as models for aspiring sculptors. The success and celebrity acquired by the Baumanns caused the industry to spread, and wood carving soon became the winter occupation of every household in the vale of Hasli. But there was no regular market for their productions, their only customers were casual visitors, their only agents hotel porters and small shop keepers who took the lion's share of the profits. The trade wanted organizing, in fact, and after several tentative efforts in this direction, the Brothers Wirth established their extensive workshops, where several hundred sculptors of the Oberland now find regular employment. In this industry, as in almost every other, the best results are obtained by a division of labor. Every carver has his or her specialty. Some prefer to shape groups of animals, others like better plants and flowers, others again take to building miniature chalets and making curious caskets, and what they like the best is generally the best done. Elaborate artistic furniture is also made in great variety in the establishment of the Brothers Wirth. In 1862 the industry had become so important that the Cantonal Government deemed it expe-

dient to found a school of design at Brienz, which is maintained by the State, the communes and the fees of pupils, the last, however, being little more than nominal. In 1869 a master modeler, maintained in like manner, was appointed for the instruction of the carvers of Interlaken. The pay of a sculptor varies from two francs a day for beginners to five francs for the more expert, among whom is a large proportion of women, their natural tastefulness and deftness of touch making them formidable rivals to the men. Brienz is the headquarters and chief mart of the trade, which has entirely changed the character of the town, and gives it an appearance of prosperity that in former years was conspicuous by its absence. The number of male and female sculptors employed at Meyringen and Brienz amounts to 2,500, and their industry brings into the district some two million francs a year.

Successful enterprise is always a healthy and stimulating influence, and the success of wood carving at Brienz suggested the idea of making parqueterie and chalets at Interlaken. The former has already grown into a large business, the annual production of one establishment alone amounting to nearly 700,000 square feet of parqueterie, valued at half a million francs. Chalets are made for use, not for show, in parts, and, the parts being numbered and arranged to fit without trouble, a man may order a house by post, have it delivered by rail and enter into possession, all within a few weeks. Attempts have also been successfully made to turn to account the indigenous stone of the country—variegated marbles, which are found in great variety, as also a soft stone peculiar to the Oberland, which, while easily worked and susceptible of a high polish, acquires by exposure to the air an adamantine hardness, and has the further quality of being almost indestructible by fire.

### Advice to Watchmakers' Apprentices.

BY A MAN WHO HAS SPENT TWENTY YEARS AT THE BENCH.

THE ENGRAVING or cutting for enameling can be made to heighten and beautify the work very much, as, for instance, small sinks with a bright gold rim, if filled with transparent enamel, if properly cut, will, in a measure, imitate such stones as ruby or emerald. As at *a*, fig. 1, the three circles are to be filled with transparent red enamel; we do the cutting as shown at *A* in vertical section (enlarged); the dotted line *d* represents the finished surface of the enamel; the edges at *c c* show the bright gold surrounding each circle, and the conical shaped rise at *b* represents the bottom of the sink. Now, this part being slightly raised shines through the transparent enamel from two causes; first, the part *b* is polished and bright, and, from its shape, the highest part above *b* comes nearer to the surface, must enhance the brilliancy. The best of this class of effects are in transparent red and green enamels; still very fine effects like grapes can be obtained by using a half transparent purple enamel, and, in some instances, making the sink concave on the bottom as shown at *e*. For practicing, on fine close grained copper is, after gold, the best metal one can use. It must be carefully cleaned with acid and dried, after being cut, before the enamel is applied. Enamel, as we all know, is a kind of glass colored with different kinds of metallic oxides. The kind of glass used as the base of all enamels is called fritz; this fritz is simply a flux of soft glass ready to receive any color we may wish to add. It is made of different degrees of hardness, this hardness, as a rule, agreeing with the temperature at which the fritz or flux melts, it being easy to reduce the temperature at which the fritz melts by the addition of borax or sal-tartar. This reduction of the melting point generally keeping pace with the hardness of the enamel, and its power to resist the acids used in coloring it. The best method for the pupil who is ambitious in this way is to first learn to cut (engrave) and prepare his work properly for enameling, and then procure black enamel and learn to fill and fuse such patterns as are easily managed—like broad

incised lines such as are shown in fig. 2. Such lines are simply cut in with the graver, a flat bottom one shown (enlarged) in cross section at *D*. Black enamel can be bought in lumps of irregular shape of about the size of peas. This must be broken up still finer with a very hard steel hammer, when it is to be reduced to powder in an agate mortar. These mortars can be bought of almost any lapidary, and those with fewest dark lines are the best. The crushed enamel is ground to a powder with an agate pestle in this mortar; even the grinding of the enamel is attended with no small amount of manual dexterity. The motion given to the pestle is a sort of double rolling—a swinging around of the pestle at the same time the pestle is slightly revolved. The enamel should not be ground too fine, and the size of particles will depend on the job to be done a good deal. As, for instance, for lines at fig. 2 the particles should be about the size of o emery. The grinding should be continued until no particles remain in the mass larger than described. The mortar should be nearly filled with water, and, after agitating the particles, the water should be poured off to carry away the very fine particles. Now, fill in the lines as show white at fig. 2 with the paste of ground enamel and water. In large work a very soft towel or napkin is used to absorb the water. A quill, cut somewhat like a toothpick, will be about the most convenient spatula to fill in such lines. The lines must be filled more than full as the enamel sinks when fused, and generally has to be filled the second time if it is desired to polish off

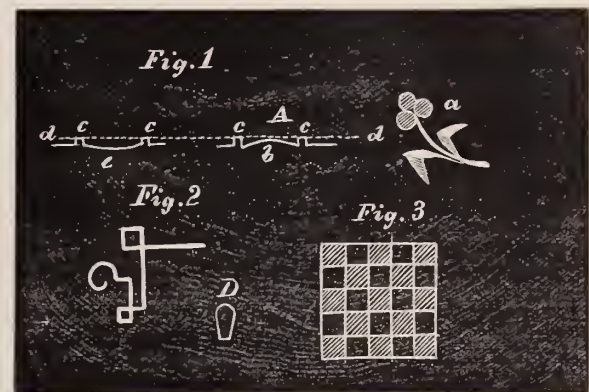

smooth and flat. In the majority of cases such black lines are left a little sunk, and the glass from the fusion is left undisturbed on the surface which is far enough below the metal to escape the action of finishing the gold surface. But for fine enameled work the enamel should rise above the gold and be ground off with fine emery and water, and a final polish given with a boxwood lap and putty powder (oxide of tin) and water. Such trifling work as shown in fig. 2 can be fired on a charcoal with the blow pipe. White enamel can be used in the same way only it is a little harder to grind and manage. A sort of checker board pattern of black and white squares, as shown at fig. 3, is a good specimen for a beginner, only stick to the black until you get to understand something about it. A margin of metal should surround each square, and the white squares should be enameled first, generally, although occasionally the reverse is the order of proceeding. As the writer hinted some time back, enameling is an art only to be acquired by patient practice under instruction if one desires to excel. But by cutting your own designs and getting them enameled you will strike the true economy, as some of our best enamelers are but sorry engravers. To any person who is bound to learn I would say, learn to cut as has been described, then take a few lessons of some enameled. An emery file made of very fine flour of emery and shellac melted together is the best to grind off the surface before the putty powder and water is used. We have several books which pretend to give instructions in enameling, among them "Gee's Gold Worker," and with all due deference to Mr. Gee's work, which in other respects is an admirable one, and should be in the hands of every working jeweler, I would say he gives very little that can be of use in enameling. Among the recipes are several kinds of fritz all correct and useful, but the reader must not imagine because he knows the composition he is going to get the results which he sees

others; or, to state it different, that he (the reader) is going to get the same results with the same material that a skillful enameler will with precisely the same material. For this reason, if no other, you prepare the work and let the enameler have the job he is almost sure to excel in. Colored enamels can be bought as well as black and white, and when used are to be ground in an agate mortar and treated as described for black enamel. Enameler's furnaces can be bought of any first-class material house, as well as the colored enamels ready to be ground as directed for the black. A job after it is filled with enamel should be dried slowly and not allowed to cool off before it is fired, *i. e.*, the enamel melted. The reader may think the writer is not very gracious in starting on a subject and then telling him that there is no hope of his mastering it. Now, I do not wish to be understood in this way. I merely wish to forewarn the reader that it is an art in which to excel he will meet with so many obstacles that it is safe to say that out of ten who will make the attempt nine will fail more or less. In my next communication I will give receipts and formulas from the very best authorities, with notes and corrections from my own experience. To illustrate: we have a recipe calling for sillicious sand; now all sand is more or less sillicious, but all sand will not answer as well; but if we know what we want we generally know when we get it; consequently if we try a given kind of sand and it does not give the desired result we know where the trouble is, and without changing the other ingredients simply try another specimen of sand.

### How to Make and Engrave Silver Bangles.

BY EXPERT.

THE INCREASING demand for silver goods induces me to give a few additional hints in regard to silver bangles and ornaments in the so-called antique styles. Monograms of letters cut in relief, and then oxidized, like the antique coins so much in vogue, is a desirable novelty. The method of cutting is quite different from ordinary engraving as also the effect. The manner of proceeding is to lay out the letters as usual (after facing off the coin—usually a quarter of a dollar), and then proceed to produce the letters in relief somewhat after the manner of the wood engravers. The designing or drawing of the letters will have to be changed a good deal from those to cut in the usual way. A little study of the effect to be produced in conjunction with practice will enable anything like a skillful engraver to catch the idea. We will suppose, for an illustration, we have the letters J. O. S. to combine in a monogram and cut in this way. I might as well say here this is no cheap style of bangle, but rather something new and nice, and when made is to be paid for. And if only a few are made and sold, still it adds to the dignity of the place where they are made, and appearances in this world is a great deal. The letters are designed a little broader on the face than where they are to be cut in in the usual manner, as shown in fig. 2, together with the border, shown at *a a*. We next, with a broad, flat-bottom graver, proceed to reduce all that portion of the quarter between the letters and the border. This is best done by *wriggling*, as it is termed, which is worked by holding the graver pretty well up as shown at fig. 3, where *d* represents the graver and *f* the job. This wriggling should be crossed and re-crossed until all the parts surrounding the letters are reduced below the face of the letters about  $\frac{1}{16}$  of an inch. The cutting should be done so as to make the reduction as near level as possible after the wriggling is done; by means of a coarse matting tool the surrounding surface should be brought up to a coarse stippled surface. Such a matting tool can be made by driving a center punch into the end of a piece of soft steel as shown at *D*. A little practice in making such a matting tool will enable one to produce a tool of superior excellence. There should be no burr raised by the center punch removed, as it all serves to enhance the irregularity of the matting. Any of the

coarser matting tools can be used, or a punch with a slightly convex face. Even the surface left by the wriggling, if skillfully managed, can be made to give a very fine effect. A great variety of finish can be given to the letters, but the management will be found quite different from the ordinary bright cut letter. Specific instruction can hardly be given, but the style of ornamentation for such letters will readily suggest itself. The main thing is to obtain a letter in strong relief, the mere working it into a rustic or other ornamentation is simple enough. In such matters I have found if the pupil has a vein of originality, the best way is to give the principles and he will soon strike out something better than if he tried to follow a routine. After the ground or surroundings of the monogram is sunk to sufficient depth, there can be letters or objects sunk still deeper into the surface; these are a little difficult to show in the cut, but a brief description, I think, will help us out. The letters of the monogram are left in relief; all the surrounding surface between the letters and the border are sunk to the depth of about  $\frac{1}{16}$  of an inch and matted; into this matted surface intaglio figures and letters can be cut still deeper. After the oxidizing these cut in designs will be still darker and add a great deal to the effect. The best tool for cutting in of such work is a round-bottom graver. The so-called oxidizing is really sulphurizing, as it is best done with a solution of liver of sulphur. A solution of one part of liver of sulphur and two parts of water will, in a few seconds, give the peculiar shade so much admired. Wash off the bangle with water, and, after it is dry, rub with a stiff brush and the extreme high portion will begin to brighten; now it is when the sunk letters and figures will begin to look to advantage. In fig. 1, the trident and fishes mean nothing, but are only put in to give an antique look to it. A solution of chloride of platinum will



give a fine steel gray to silver work of this kind, but there is nothing that will beat the solution of liver of sulphur. Bright cutting can be added after the oxidizing, and if it would only stay and stand as it looks when fresh cut it would be very desirable, but it very soon blackens and the trouble is it cannot be cleaned and restored. To make the leading or dominant letter full faced with a flat surface as shown at fig. 1 gives a very good effect, as it and the border soon wears bright and shows in strong contrast to the other letters, which have rough or tooled surfaces. Even the brushing with a stiff, hard brush brings out the relief. Bangles with relief letters of this kind can be set with small stones or half pearls, as nothing relieves such work more than an oxidized silver surface. Curious and original effects can be made by a combination of *repoussé* work let into a coin. I speak of this more as a curiosity than as a desirable or profitable product of the workshop. If we take a silver quarter dollar and turn it out on one side to the depth of two-thirds the thickness, as shown in vertical section at fig. 4. We next take a piece of thin sheet silver, a trifle too large to go into the recess shown at *n*, fig. 4. The piece of sheet silver should not be too thin for several reasons; first, it will not work as well, and next it should nearly fill up the turned in recess, only leaving a margin of coin to form a border, as shown at *n n*, diagram *F*. The disc of silver just

mentioned should be laid on a block of wood sawn off across the grain, and, by means of punches of different forms, the disc of metal *k*, fig. 5, is indented into the wood, care being taken not to break through the metal. This part of the work is merely a delicate *repoussé* work. I do not wish the reader to imagine that this is a coarse, clumsy art, for it is not. In the hands of a skillful artisan this process is capable of producing exquisite work. The outline should be made with a tracing point, when, by means of punches shaped like miniature cold chisels (both flat edged and concave) the outline must be followed. Of course the chisel shaped punches must be delicate enough so as not to break up the sharpness and perfection of the outline. We next by broader faced punches force the parts inside of the outline into high relief, as shown in fig. 6. After the relief is produced the edges is filed so it will merely fit into the recess shown in diagram *F* and in fig. The back of *k* should be filled in with soft solder so that the whole face of *k* can be gone over with punches from the face side after *k* is soldered into place. The finer and more delicate parts can be touched up with gravers of different forms, and if the joining at the border *n* is properly managed it will be very difficult to detect. The coin should be oxidized and given an extra hard rubbing with a stiff brush.

---

### Infringements of Patents.

IN A RECENT suit for infringement of patent, tried in the United States Circuit Court for the district of Indiana, Judge Woods charged the jury as follows:

In an action at law for infringement of a patent all parties who participate in the infringement are liable, although some are simply acting as officers of a corporation. All parties who participate in a tort or trespass are liable, and a man cannot retreat behind a corporation and escape liability for infringements in which he actively participates.

It is for the court, as a matter of law, to construe a patent, and for the jury, as a question of fact, to determine whether it has been infringed, and the amount of damages that should be allowed.

In an infringement suit the burden is on the plaintiff to show the amount of damages he has suffered; and if he furnishes reasonably satisfactory evidence on that subject, he is entitled to substantial damages; otherwise to nominal damages.

On the question of damages, it is competent for the patentee to prove the prices at which licenses were granted under the patent while it was in force; but in order to be competent evidence of value, the prices agreed upon must have been prices fixed with regard to the future use, when, there being no liability between the parties, they are presumed on both sides to have acted voluntarily, and therefore to have made up their minds deliberately as to what was a fair price. Such arrangements, licenses thus granted, fees thus fixed, are competent evidence to consider in determining what the actual value of an invention is and what the recovery ought to be for its use.

It is not competent for a patentee to prove the prices paid for infringements already perpetrated. Such settlements are not at all admissible on the subject of value.

The value of an invention for which an infringer is liable is the value at the time of the infringement. A man who has got a patent owns it as property, and if anybody sees fit to infringe it he is bound to pay for its fair value; and the fact that there is something else as good or better does not entirely destroy its value but may affect it.

The doctrine of a confusion of goods has no application to a suit for infringement of a patent, especially where there is only a confusion of bookkeeping and not a confusion of the articles themselves, the articles being incapable of mixture.

If a party shows an unwillingness to let the truth out, and keeps back facts and the means of getting at facts in his power, then the

jury is warranted in drawing the strongest possible inferences against him which may be drawn from the evidence actually given in favor of the other party; but if he comes forward with his books, furnishes all the evidence in his power and is fairly candid in the matter, no inferences should be drawn against him, except such as are fairly drawn from the evidence adduced.

Every one is bound to take notice of the existence of a patent and of the rights of parties under it. Like the record of a deed to real estate, the record of a patent at Washington is notice thereof to all the world.

---

### Ingenious Music Boxes

IN THIS land of abundant music, where every female child almost is taught to play the piano, and the very street arabs rejoice in mouth organs, it would hardly be thought that there could be much of a demand for music boxes. But there is, and our people are not only the largest purchasers of them, but pay the highest prices for fancy and intricate music boxes. A dealer in such musical instruments, exhibiting an elegant affair of the kind, encased in a handsome rosewood box, gave the following information regarding this branch of industry:

"That is undoubtedly," he said, "the most perfect mechanical music box in this country. It was made in our factory in Sainte Croix, Switzerland, under several recent patents, which make it much superior to instruments of this kind as ordinarily constructed. The price, too, is very low, only \$1,500. Is that the highest priced instrument we have? Yes. We do not keep higher priced instruments in stock. We only make them to order. We have got as high as \$6,000 for a box, but the music produced was not so perfect as this, because the instrument lacked the patented improvements which this has. This has a regular set of reeds, with a mechanical arrangement producing an almost perfect imitation of the human voice, together with bells, drums, castanets, and the harp, all of which are used with the finest orchestral effects. Besides, by means of interchangeable cylinders, the number of tunes may be increased to any extent the owner may desire, so that if he tires of one set of tunes, by a trifling expenditure he can get another—in fact as many additional sets as he chooses, embracing tunes of his own selection, or ours, whichever he may prefer. This box plays forty-eight airs without change of cylinder. Rather high priced music you think? Not at all when you come to consider the quality and amount of labor involved in the construction of these instruments, the mechanism of which is as intricate, in expensive boxes, as that of the watch. Indeed, about the same amount of mechanical skill is required in their construction as is needed in making and putting together the delicate machinery of a fine watch. Our different grades are the ordinary box, with no accompaniment, and those with bells, castanets, drums, zither, piccolo, etc., producing the finest results in expression and harmony. Indeed, the harmony produced by some of our expensive boxes reaches the sublime in point of musical expression.

"We employ in our factory in Switzerland about 800 skillful artisans. Our instruments are shipped to all parts of the world, the instruments playing the favorite airs of each country to which they are sent. We manufacture both small and large boxes. Prices range from a dollar up to \$6,000, or more if a purchaser desires. The musical mechanism of these boxes is also placed in many fancy articles made chiefly in France and Germany, such as albums, work boxes, cigar cases, writing desks, clocks, jewelry cases, etc. In clocks the air is played when the hour strikes. We place the mechanism also in chairs, which play when you sit down upon them, automatic figures, mechanical toys, etc. This mechanism, although requiring great skill in its construction, is simple in ordinary boxes. It consists of a brass roller with projecting points, a steel comb, the teeth of which give the sounds, a spring to give the revolving motion to the cylinder, and a fly wheel or fan to regulate the revolving

motion. The rough parts used in the construction of a music box, such as the bed plate, the blank roller, the mainspring, the comb, the running gear, etc., are made in large machine shops in Switzerland, which furnish these parts to all the box manufacturers there. There are only two of those shops that turn out really good works in the shape of rough parts. The music has first to be arranged for the boxes by thorough musical artists. The cylinder is then given to a person—generally a woman—who, with the aid of the written music and a very ingenious machine, marks the places on the cylinder where the points are to be inserted. Another person then drills all the little holes and another inserts the points. The cylinder is then filled with molten cement and then placed on a lathe and revolved very rapidly. The cement adheres to the inside surface holding the points, and is then allowed to cool. On another machine the points are filed down so as to be of equal length. While this is going on the comb is turned, the turner having first to file the teeth to give the proper flexibility. The tone is lowered by filing near the base, and heightened by filing near the point. The cylinder is set on the bed plate, and opposite to it the comb is fastened, so that the points of the cylinder and the teeth of the comb exactly meet. These are the main features of the ordinary mechanical music box. Of course, the construction and adjustment of the various accompaniments, etc., in the larger boxes are more complicated.

"We make large and expensive music boxes of various styles to order. One style resembles a handsome writing desk, inlaid with ornamental woods and having a desk attachment. Another style has the form of a side-board. It is made of ebony and has four panels of porcelain decorated with artistically painted flowers in gilt, bronze, and ordinary colors. The top is of plate glass, so that the works can be seen without opening the box. In fact, we make boxes to order in many novel and expensive styles. Of course, our trade is more largely with the wealthy classes, although the price of our cheaper productions bring them within the reach of the very poorest. A box which used to cost \$25 now costs only \$5. All of our music boxes are intended solely for private entertainment, the music produced by them being too soft to be used on public occasions."

---

### Travelers' Taxes.

A GENERAL WAR has been declared against the license taxes imposed on commercial travelers in certain Southern and Western sections of the country, and the prospects are that these taxes will soon be abolished. The following are some of the places where such licenses are imposed and the amounts exacted:

Beaufort, S. C., \$10 per week; Bennettsville, S. C., \$1 per day; Memphis, Tenn., \$10 per week, or \$25 per month; Mobile, Ala., \$3 per day; Augusta, Ga., \$3 per day; Natchez, Miss., \$2.50 per day; Jessup, Ga., \$5 per day; Georgetown, S. C., \$3 per day; Tucson, A. T., \$50 per three months; Orangeburg, S. C., \$2 per day; State of Virginia, \$75 per year; State of Nevada, \$100 per year; State of Texas, \$35 per year; New Mexico Territory, \$250 per year; Florence, S. C., formerly exacted one dollar per day, but the authorities have abolished the tax.

The Superior Court at Quebec, Canada, has decided that the tax imposed on commercial travelers by the city is illegal, and in a test case brought before it condemned the city to pay \$150 damages for arresting a traveler who displayed samples without first obtaining a license from the city corporation.

At the recent annual meeting of the National Association of Commercial Travelers, held in Boston, the following resolutions were adopted:

*Whereas*, Certain cities and States in these United States have upon their statute books and are enforcing certain discriminating and excessive licenses and tax laws against commercial travelers from other States and cities; and

*Whereas*, It is clearly unconstitutional for any State or municipality to enforce said discriminating laws; therefore, be it

*Resolved*, That the National Association of Commercial Travelers of the United States do most earnestly protest against the passage or enforcement of any such laws.

*Resolved*, That so far as the exchange of produce, manufactured articles or merchandise is concerned between the different locations of these United States, we are most emphatically for free trade.

*Resolved*, That we cannot see the wheels of commerce clogged by these license and tax laws without putting ourselves on record as opposed to the whole system, and in order to work systematically for the abrogation of these said laws, be it resolved that a committee of three (to be called the Legislative Committee) be appointed by the convention, whose duty it shall be to communicate with the Senators and Representatives in Congress in reference to such legislation as the exigencies of the case require.

*Resolved*, That this committee be instructed to carry out such means for effecting legislation in the interests of commercial travelers as may seem to them best, and that the members of this association pledge themselves to assist and aid in all honorable measures which may be instituted by Boards of Trade, Chambers of Commerce, and similar bodies or associations looking to this end.

*Resolved*, That this association strongly favors the bill introduced by the Hon. Mr. Brewer in this interest.

---

### Something About Cameos.

NEWSPAPER reporters are aware of the fact that the general public likes to read about anything pertaining to jewelry, so when news is slack they "interview" some one in the jewelry trade and faithfully report whatever he tells them. The following is from the *New York Tribune*:

"Well, there are few people who can afford to do that!" So thought a *Tribune* reporter as he watched a man in a little room overlooking upper Broadway, as he sat pounding up diamonds with a pestle and mortar. "That's not the only costly part of cameo making," said Mr. Zoellner, the artist, as he pounded away at the little uncut diamonds; "it takes eyesight, a great deal of time and patience and years of experience. Then the onyx stones, from which the cameos are made, cost considerable, sometimes as much as \$50. The choicest have a layer of cream-colored stone on a dark chocolate-colored base. But some people like the red, orange, black, or shell-pink stones just as well. You know they are found in the Uruguay Mountains and in Brazil. The onyx is a half-precious stone of the quartz family. It is taken to Europe and cut into oval or oblong shapes, and then I have to pay ten per cent. duty to get it through the Custom House."

The cutter of cameos turned to his lathe by the window and rubbing some of the diamond dust, which he had mixed with sperm oil, on the end of a small drill, began his work. He was making, for a cabinet piece, a large cameo, two by two and a half inches, one of the largest ever cut, of an old gentleman in Germany, whose portrait was placed before him. "I have 125 of these soft iron drills," said he; "they are made soft so as to catch the diamond dust, which is the only thing that will cut a cameo. A cameo is indestructible except you take a hammer and smash it. It is an old art and was practised by the Romans, Greeks and Egyptians. Dr. Schleichmann found some cameos in good preservation that were probably 3,000 years old. It takes several weeks to cut a large piece like this. Afterward it has to be polished with tripoli, first being smoothed with emery and oil, using the lead instruments similar to those for cutting. It is easier to cut a profile than a full face portrait. Some people prefer intaglios, in which the portrait is depressed instead of raised. They are made on sards and cornelians, the former being a dark, reddish brown and the latter a clear red. They are harder

to make than cameos. I have to keep taking impressions in wax of the work as I go on. I usually cut portraits from photographs, but sometimes have done them from life and even from casts of dead persons. I also cut fancy designs of all kinds for pins, lockets, etc. In the night I have a globe containing distilled water with a little sulphate of copper which concentrate the light of the lamp on my work."

Among the portraits cut by this artist are those of ex-President Hayes, Mrs. Hayes, William Cullen Bryant, J. S. T. Stranahan, the Rev. Dr. Buddington, Bayard Taylor, Peter Cooper and others. A large cameo copy of Gerome's "Cleopatra before Cæsar" is held by the artist at \$1,500.

And this paragraph we find in the Philadelphia *Times*:

"Cameos are cut in this country, as well as in Europe," said Mr. Isaacs, the Chestnut street jeweler. "The finest American work, which of course is not by any means equal to the best foreign work, is done in New York, and a little of it—a very little, by the way—in Philadelphia. That our people should turn out work equal to that of the best foreign artists is scarcely to be expected, since cameo-cutting was almost unknown here thirty years ago, whereas in Europe some families in Florence, Rome, Paris or Naples have pursued it as a calling for half a dozen generations. Cameos are not as extensively worn as formerly, these fashions come and go, but a great many persons still wear them because they are heirlooms or relics of some departed ancestor. A cameo is where the image on the stone is raised above the surface; where it is cut in the stone it is known as 'intaglio.' The stones generally used for this purpose are the onyx, sardonyx, bloodstone and agate. The latter is the hardest stone to cut. The onyx consists of several layers and the cameo is obtained by cutting the figure out of the upper layer, when it appears as a raised medallion upon the lower one. It is the easiest stone to work on. The art of ancient cameo-cutting was entirely lost during the Middle Ages, and only reappeared during the Renaissance. The Romans, in my opinion, excelled the Greeks in this branch of art; but the moderns have never approached the ancients in accuracy of design or finish. Look at this head of Augustus Cæsar, cut on a species of agate harder than any we know anything about. That sort of work could not be done now. It was found in Rome during some excavations made a few years ago near the Capitol, and though not much larger than a quarter of a dollar is worth \$75. The sunken portions of the face, the whites of the eyes, the hollows of the cheeks, are polished. That could not be done by any cameo-cutter alive to-day. It is positive proof that the cameo is an antique. The finest specimen of cameo-cutting in the world are the classic figures cut on what is known as the Mantuan vase in the Brunswick Museum. The base is cut out of a single agate and is seven inches high by two and a half in width."

---

### The Credit System throughout the World.

THE COMMERCIAL community recognize more and more the value of our consuls as promoters of American trade and commerce. The State Department has just issued a new volume of valuable information of which we give a synopsis.

The Board of Trade, of Scranton, Pa., having recently represented to the Department of State that reports on the system of credit which prevails in the several countries of the world would be greatly appreciated by the financial and industrial interests of the United States, the consuls of the United States were requested to prepare reports on that subject. These reports have been received at the State Department and published. Following are condensed statements from the principal consulates:

Consul General Stearns, at Montreal, Canada, says:—"The

experience of merchants and traders in this city and throughout the Dominion has been that the credit system is of great assistance in developing and sustaining all business enterprises. The average allowance to cash buyers, taking business all through, is five per cent. discount, thirty days being considered cash. The retail clothing stores, however, generally allow ten per cent., dry goods and fancy goods four to five per cent. and provisions two and a half per cent. But at retail stores buyers, if at all responsible, are encouraged to keep accounts and settle quarterly or half yearly."

David H. Strother, Consul General of the city of Mexico, says:—"It is generally considered that credit is essential to trade in Mexico, and that without it all the more extensive commercial transactions would cease, and the leading business establishments would be obliged to close their doors. Nearly all the great mercantile houses in Mexico city and State sell largely on credits of from four, six to eight months, and often for longer periods."

Consul Morrel, of San Jose, Costa Rica, says:—"Until lately importers obtained all the goods asked for in Europe on credits from six to twelve months, especially if the debtors agreed to consign coffee in payment in lieu of retaining bills; but several heavy failures of importers having occurred European credits have been greatly restricted."

Consul General Andrews, at Rio Janeiro, says:—"The long credit system of this country is a subject of frequent complaint in all business circles; the system has probably been caused, in a large degree, by the great extent of the country and the difficulties of communication. At least three-fourths of the volume of business will be on credit. With a capital of \$20,000 it is usual to be owing about \$100,000 or in that proportion."

The report from Buenos Ayers says that about seven-eighths of the business is done on credit in the Argentine Republic.

In Bermuda "fully four-fifths of all foreign products for domestic use are sold on credit. All time sales become due on the 30th of June when there is no agreement to the contrary." An effort is being made to abolish the system of long credits.

In Cuba the bulk of trade is based on credits. "The exporter of sugar and molasses, whose business reaches a volume during the year of many millions of dollars, may have a capital of from \$25,000 to \$50,000, but he relies on credits generously granted him by bankers of the United States and Europe. The wholesale provision dealer purchases his supplies at three, four, six and sometimes eight months' time. He in turn sells to the planter on credit, formerly on twelve months time, but now rarely more than one to three months are granted."

The reports from Europe are very lengthy. Consul Grinnel at Bradford says in part:—"Credit in the wholesale branch prevails to a very great extent in proportion to the volume of business transacted, varying in time from one to six months, the retail business being conducted mostly for cash and to considerable extent by cooperative stores. The losses in connection with the latter (the retail) when credit is given are considerable, in some cases amounting to five per cent. of the total sales; whereas in connection with the former (the wholesale) the losses incidental to business amount to probably no more than one to two per cent. Interest is also usually demanded on overdue accounts, the time allowed for payment being specified on the billheads. Credit is not extended by tradesmen to the laboring classes as readily as to persons in business, unless they are old and well known residents."

Consul Shaw, of Manchester, says:—"Borrowers who can show that they have made 'a good thing' by buying in a risking market are trusted all the more freely on that account."

Consul Piatt, at Cork, Ireland, says:—"Without credit this community, being almost entirely agricultural, could not exist, as the whole commercial structure rests on the produce of the land, and the tillers are generally poor, owing, as many claim, to the oppressive land system which has obtained for centuries in Ireland. It would

be impossible to develop the resources of the country without an extended system of credit."

In Scotland:—In large transactions common terms are cash in three months, with  $2\frac{1}{2}$  per cent. discount if paid at the end of the three months; but every trade or manufacture has its own terms. It is understood that no discount is allowed if the account be not duly paid.

The evils of credit are most conspicuous among the working classes and among that large part of the community who have no realized means or estate and who are dependent for their support on their daily labor.

Consul Harper, of Munich, says:—"Germany is not rich enough to do without credit. The credits are here longer than in France or England."

Consul General Bremer, at Berlin, says:—"The percentage of business done on credit is undoubtedly large."

At Dresden:—"Credit in the wholesale trade is absolutely necessary to stimulate and encourage business, and manufacturers are forced and obliged to extend long and often risky credits, as competition is so sharp among them and most companies are well supplied with capital sufficient to enable such extension and take such risks."

Adolph Stein, Vice Consul at Brussels, says:—"In Belgium, although relatively a rich country, there are no large associations of capitalists that do business, and most all tradesmen begin trade modestly and with little capital. Therefore, credit which is confidence in the solvability of a person, is indispensable for the success of trade. It might even be said that trade in this kingdom would be nearly impossible without credit."

Consul Frisbie, at Rheims, France, says:—"It is next to impossible to form any estimate of the proportion of cash transactions to the whole volume of business, but it may be taken for granted that the former are mainly confined to dealings in the prime necessities of life."

In Switzerland:—"The credit system in several branches of the business is largely in excess in proportion to the volume of business, while in reference to the manufacture and export of watches and of cheese the proportion is said to be a normal one."

In Italy:—"Credit, if given at all, is very limited, unless against good collateral securities. Advances and discounts in Florence last year, as made by six banking institutions, amounted to \$275,551,723.08."

In Portugal:—"Trade is mainly carried on by credits."

In Spain, Consul General Reed, at Madrid, says:—"The extent of credit in proportion to the amount of business transacted may be safely estimated at one-fifth of the same."

In Austria:—"The amount of credit given depends more on the commercial reputation of the individual than on the character of the business. Most of the small manufacturers depend almost entirely on borrowed capital or advances made on orders before the delivery of the goods, while for more extensive operations conducted by responsible parties credits are easily found, although generally at high rates, but if the borrowers are unknown or in great commercial straits, these rates become at once exorbitant and ruinous. It is estimated that in general the amount of credit so received may equal about seventy-five per cent. of the volume of business or interest involved."

Turkey:—"Credit is nearly universal for actual requirements of life, but colonials, imports and exports, generally demand credit. The exact proportion of credit to the volume of business is impossible to determine in a country where there are no statistics, but it certainly exceeds fifty per cent."

In Russia:—"From one-half to two-thirds of the business is done on credit. In some branches nearly the entire trade is done on credit, and generally speaking trade in Russia would be impossible without it."

(Copyright, New York. All rights reserved.)

## Russian Reproductions

At the Metropolitan Museum of Art.

[BY JOHN W. MILES.]

Continued from Page 311.



Assyrian Seal from a Scythian Tumulus.

URING THE continuation of this examination of these highly interesting pieces, I shall keep them as nearly as possible in chronological order. I illustrate, therefore, in figure 9, a curious covering for the tip of a quiver case, in electrum. Although a Scythian relic, since it was found in a Scythian tumulus, we can hardly ascribe it to any portion of the Scythian armour. As we have seen, the Scythian warriors provided a pocket for carrying their arrows, in the Goryt, and it is not likely that a second receptacle was used for those weapons, neither do we find in the representations of the Scyths any accoutrement that even resembles a quiver. It is not even probable that it was used by a Grecian, since the bow was not a Greek weapon and was rarely, if ever, used by them; the archers, which sometimes formed part of their armies, being recruited from the colonies bordering the Black Sea, and, without doubt, principally from the Scythian nation. I am of the opinion, therefore, that it belonged originally to a Persian, or perhaps even an Assyrian, and the latter appears more correct since among the numerous smaller objects found in the Scythian tombs was an Assyrian seal, which will be found illustrated in the initial letter of this chapter. That this seal was, even at the age of the tomb, an antiquity, I am inclined to believe. The Scythians were at one time (if we may believe Herodotus\*), the supreme rulers of all Asia, and this seal may have been one of the objects taken with them on their expulsion from Medea by the exasperated people of that country. The placque, however, is of a style of a much later date (fourth century, B. C.), and strongly characterized by Scythian sentiment. It is not at all unlikely that it may have been used by a Persian resident in Scythia, and it may even have been made by a Greek, under directions of the Scythian king, for an Assyrian or Persian favorite. Indeed the line of conjecture regarding its origin and destination may take a number of directions and still be wide of the truth. In an estimate of the things of antiquity, that which we know and that of which we are uncertain, bear a very unequal proportion—the latter having a tremendous majority.

As may be seen, the placque is of triangular shape and pierced with holes on the outer edge for attachment to the quiver. It is also bent into a concave form. Along the upper edge is a dentilated border, and just below a group of two animals has been stamped, probably with a die. One of these animals we have no difficulty in recognizing as of the roebuck species, but the other is partly that of a panther and partly fabulous. Four or five similar pieces have been uncovered by the spade.



Tip of Arrow Case, Figure 9.

A placque of gold, which by some is thought to be a shield covering, and by others a Phiale (*phiale omphalatos*), is, unfortunately, of so elaborate a character and worked so minutely that its illustration

\* Herodotus, IV., 1.



upon the small scale required for these pages would give too imperfect an idea of its ornamentation to warrant me in making the attempt. It is 9 inches in circumference, and the work is a mass of detail, resembling filigree in fineness. If it is a shield covering—as the twisted loops of metal, which appear at opposite points of its circumference, might imply\*—it is certainly a most remarkable instance of Oriental splendor. If it is a Phial, which we know was used for libations and ceremonial purposes, it is but another proof that the ancients devoted their highest skill and richest art to the service of the gods. At its center is a boss, which, from its appearance, would seem to have held some other attachment, now lost. In a circle surrounding the boss is a sort of zone, containing dolphins and other fishes of different sizes in great profusion. From this, in radiating curves to the circumference, are several divisions, holding at their terminations heads of the Medusa. Between these divisions we find the heads and faces of Scythians, bearded and with a menacing expression, wearing the pointed cap of their nation. Other spaces have boars' heads, and every conceivable point, where decoration could be artistically used, is occupied with chased or *repoussé* work. While there may be a doubt regarding the uses of this piece, there can be no hesitancy as to its artistic excellence, which is quite similar in style and character with some of the Etruscan monuments. However, it is a Greek work of the fourth century, B. C. It weighs 163½ zolotinks and is 21 karats fine.

We come now to a piece, the uses of which is not a matter of doubt, but which is of more than usual interest, by reason of its being the only one of the kind known in the noble metal. The *Pilos* (*Πίλος*—a metal cap), which is shown in figure 10, may not exhibit as much artistic beauty as some of the pieces previously illustrated, but while we have examples of these objects in iron, bronze and bronze gilded, this is the only one in massive gold. I think it will be found to be a fact that the helmets of the warriors were always made of metal. Many of them are of this form, and some of the Grecian helmets have also side pieces for the protection of the cheeks. These, however, are without the side plates, neither are they ever represented upon the coins nor the sepulchres, other than in the form of our illustration. The design of this *Pilos*, although fantastical, is somewhat upon the familiar Ionic order. The lower band is treated conventionally with leaf and flower work. Above this, a shell, from which rises large volutes, and this is three times repeated around the helmet. The gold has been beaten up to form the design, and the ground cut out, leaving it open worked.

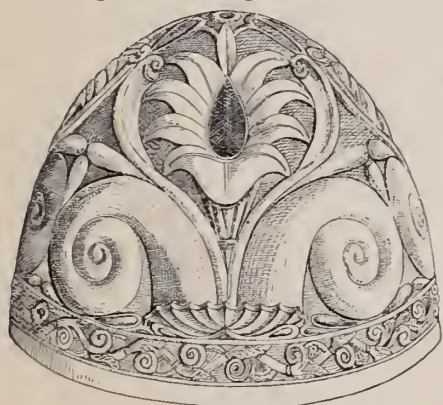

Massive Gold Helmet, Figure 10.

In measurement, the height and diameter are equal (7 inches). With this piece, I leave the section, already too much extended, which has been devoted exclusively to the Scythian and Greco-Scythian treasures. We have seen how a nation, barbarous by nature and tradition, assimilated to itself a culture and love for the beautiful, under the influence of a neighboring nation possessing both in the highest degree, and yet, although appreciating the art that flourished so luxuriously in Greece, developed no genius of her own. In these specimens of metal work we possess, therefore, illustrations of Greek art in three different materials, gold, silver and electrum, for it is scarcely possible that the Scythians who were, like the modern Tartars, nomadic by nature and training, gave birth to any artists capable of even correctly copying the Greek style. Other pieces of the collection exhibit the varying treatment of different workmen, who were doubtless barbarians, and who sought to reproduce or imitate the superior work of the Greeks, but meeting with

very imperfect success. It was hardly necessary, in view of the close proximity of Greece, for the Scythian kings to attempt the development of art under such unfavorable conditions as those surrounding their mode of life. I opine also, that in a nation holding its greatest wealth in cattle, there was little gold and silver, and that the rich stores which have been exhumed from their buried tombs, comprised perhaps nearly all of their possessions in this material.

Regarding the art exhibited in our illustrations, the indications tend to class many of them in what Winckelmann was pleased to term the "grand style" of Greek art, and the date of most of them, established by the inscriptions and coins found in their company, would perhaps place them nearer the age of Phidias than of Praxiteles. There is manifest in the decorations a severity of correctness as a leading *motif* which characterized the period of the earlier artist—a severity very much modified at a later age, when idealization, unfettered, rounded off the angles, and while clinging closely to truth, nevertheless rendered it subservient to beauty. We have few relics of Greek art in the precious metals, nor would these have been preserved had not the tombs been held so strongly sacred, and located at some distance from the ravaging cupidity of ancient armies and the insane destructiveness of the Iconoclasts.

We are not yet compelled to leave the classic shades of Greece. The famous cameo, which will be found pictured in figure 11, is



Cameo Portrait of Ptolemy II. and his Wife, Figure 11.

indeed, for many reasons, one of the most remarkable specimens of antique lithoglyptic work extant. It is an Oriental sardonyx of very large dimensions (6¾ inches long), and having three layers. The lowest *couche*, of a dark smoke color, is semi-transparent; the next is white on which the heads are cut, and the last is almost black and has been used by the artist for making the casque and ægis of the king. In the consideration of this gem, we may find four characteristics which establish its worth, aside from the value of the stone itself. First, its antiquity, having been executed in the third century, B. C.; second, its size; third, its importance as portraits of prominent historical personages, and, fourth, its art.

It will be remembered that Ptolemy Soter (Saviour) was one of the most cultured of the kings of Egypt. It was this sovereign that established the Museum and famous library of Alexandria. The

\* These loops, for some reason, do not appear in the reproduction.

destruction of the latter by fire was one of the most severe losses that the world ever knew, and one that scholars and historians bitterly regret to this day. How much of ancient learning, how much of instruction regarding the "lost arts," how much of priceless information bearing vital relations to the world's civilization, was devoured by the flames that turned to ashes 700,000 volumes of books, can never be known or fully realized.

Following in the footsteps of his father, Ptolemy II. continued the policy of toleration of the different religious beliefs, the cultivation of literature, of arts and of sciences. The salient features of his reign are too familiar for reiteration, but their importance to the world are of sufficient magnitude to create for his portrait an interest equal to that of any ancient ruler. That the head upon our cameo is a portrait cannot be doubted. A comparison with the coins and medals which were struck during his reign establishes that fact beyond question.\* The son of Soter is here represented in the flower of his youth. His cheeks are covered with a slight beard, and his beautiful hair—the praises of which were sung by a contemporaneous Greek poet—is raised above the forehead in a manner similar to that on the heads of Zeus, and falls in waves upon the neck. The divine ægis which covers his breast in lieu of a breast plate is woven in scales and garnished with serpents. Upon it we see also the mask of the Gorgan and yet another mask, bearded, which was without doubt that of Phobos, the god of terror, and which the Greeks believed to be the son and companion of Arés (Mars). Upon the skull of the casque is a large serpent with wings. It is the serpent of Déméter (Ceres)—a divinity that the Greeks of Alexandria confounded with the Isis of the Egyptians. The star Sothis (Sirius—the "dog star"), a star which was connected with that goddess of Memphis, is placed above the head of the serpent. The casque is encircled with a laurel wreath.

Ptolemy II. was twice married. His first wife was Arsinoe, the daughter of Lysimaque, the same Lysimaque who married the sister of Ptolemy also named Arsinoe. In connection with his physician, Chrysippe of Rhodes, Arsinoe conspired against the prince and was banished by his order to Coptos in upper Egypt. Afterwards Ptolemy contracted an incestuous marriage with his widowed sister Arsinoe—a custom frequently practiced by the Persian rulers of that epoch. This action is the one blot upon his character, but it appears that she not only made him a good wife and cared tenderly for her step-children, but she also became very prominently connected with the fortunes of the state and shared equally with her husband in the honors of his reign. By reason of this marriage Ptolemy was given the surname of Philadelphus (*nearly related*), and he is distinctively known under the two names to-day. From the youthful appearance of his head upon our cameo it is extremely doubtful if the female profile is that of Arsinoe, his wife and sister. Neither is it that of the famous Berenice, his mother, as may be proven by the coins of the period. We must, therefore, believe it to be that of Arsinoe, his first wife, and that the stone was cut before her conspiracy and banishment.

From the antique examples of the glyptic art which we possess, it appears that the ancients were more fond of cutting in intaglio than in cameo. This may have been due to the fact that the engraved stones were mostly used for seals, producing the relief in the impressions. Among the early Egyptians the art of carving in relief was either very imperfectly understood or prohibited by sacerdotal law. The effect of relief which is seen in their sculptured monuments was invariably produced by incised lines, and no part of the relief surface protrudes beyond the outer surroundings. With the Greeks, however, carving in relief attained a high state of perfection—a per-

\* We can hardly estimate the value of these ancient coins and medals to both history and art. In a late address, Mr. Algernon S. Sullivan stated that the Numismatic and Archeological Society of New York, of which he is a member, possessed a collection of coins from which a history of the world could be written if all the books extant were to be destroyed. Aside from the known high character of the speaker, such a statement is too broad and important to be made carelessly.

fection nowhere more beautifully illustrated than in our cameo. This stone was at one time in the possession of the Empress Josephine of France. It has been given, therefore, the name of the castle near Versailles to which she retired after her divorce from Napoleon, and is to-day known as the "Malmaison" cameo.

The silver pail pictured in figure 12 is antique Roman, but probably executed by a Grecian artist at a period still full of past traditions in the world of art. The style is that of the second century of our era. It was found in Moldavia on the right bank of the river Pruth in a village belonging to the district of Dorohoé. The height is 5½ *verschoks*\* and the weight 9 livres.† On the upper and lower rims are borders of flower scroll work between beaded edges. The handle is also beaded with beads diminishing in size from the center towards either end. The attachments of the handle are two flat, engraved and open-work pieces in the form of dolphins. The main beauty of this piece, however, lies in the mythological representations which fill the space between the two borders and which are worked in *repoussé*. They illustrate three different legends of Greek mythology, Hylas captured by the Nymphs, Daphné sued by Apolló and Léda with the swan.

Of Hylas it will be remembered that he was a youth very much beloved by Héraklés (Hercules) and was taken by him on the famous Argonautic expedition. On their way to Kolchis in search of the Golden Fleece, the Argó stopped at Mysia where Hylas left the company seeking for water. He found the spring, but as he was dipping his urn, the Nymphs, falling in love with the comely youth, seized and detained him. Answering his calls for succor, Polyphémos went with drawn sword to assist him, and meeting Héraklés on the way told him what had happened. The two heroes continued the unsuccessful search until the Argó put to sea and left them there.

The representations of the fable of Hylas which have been preserved are very limited in number. It seemed to exercise the talents of the ancient artists much less frequently than the other two myths upon our pail. Here the figure of Hylas in the midst of four of the Nymphs of the spring cannot be mistaken. He stands with crossed feet, and resting the left arm upon one of the urns belonging to the Nymphs. Upon his face there is an expression of affliction and chagrin. At the beginning of his captivity we are told that the young lad fell to tears, and the Nymphs, sinking upon their knees before him, sought to stimulate his courage and assuage his grief by loving words. It is evident that the artist has chosen a time when Hylas realizes that his escape has been interdicted, and the necessity of accepting his fate and remaining with the young girls has become apparent. He is not yet, however, wholly reconciled to these circumstances. The Nymph grasping his arm in a posture of solicitation meets with coldness and disdain. All of the Nymphs are nude and evidently engaged in bathing, being surrounded with water urns from which the water is pouring. Upon each arm—as indeed is the case with all the other female representations upon the pail—are two bracelets, and upon the neck a collar.

The second group, of Daphné and Apolló, shows the former close by a stream of water (probably the Ladon in Arcadia), and she is filling from it her water urn. She, also, is nude, in preparation for the ablutions of the toilette. The river is symbolized by a Nymph with her arm resting upon an urn of running water. Daphné, kneeling at the stream, has already filled her urn, when the god of music, bearing his symbol of the lyre and quiver and accompanied by a little Love with a flambeau, approaches. Alarmed at the sight, Daphné lets fall her urn and opposes with her right hand the advance of the eager god. In the hands of both Apolló and the Nymph we see branches of bay.

The Homeric Apolló was a god of remarkable purity. It was only when the pride of lineage tempted the heroes and heroic families to ascribe their origin to Olympos that Apolló was furnished with love adventures, but it appears that his wooings were habitually

\* 9½ inches, a *verschok* is equal to 4.445 centimetres.

† A *livre* is equal to 96 *zlotinks*.

unfortunate. According to Ovidius, his first love was Daphné, the daughter of Péneios. Apolló, elated with his victory over the Python, saw Erós (Cupid) bending his bow and laughed at the efforts of the puny god. Erós, indignant, shot him with one of his golden arrows of love, and at the same time wounded Daphné with one of his leaden shafts of aversion. Apolló saw her and became infatuated, while she, loving nothing but the chase, flies from him. The powers of his eloquence, possessions and rank were unable to

The ancient Greeks gave to their divinities without hesitation all the passions and foibles of humanity. Even Zeus (Jupiter), the god of gods, seems to have been credited with all the emotions and weaknesses of mortals, and hence did not escape the power of love. No one of his intrigues, however, is rendered under a more beautifully poetic form than that with Léda. Léda was already married when the all-powerful god sought her embrace. The terrible thunder and lightning which always surrounded him in his proper person



*A Silver Pail, Figure 12.*

overcome her aversion. Exhausted and nearly overtaken, the Nymph falls upon the banks of her father's stream calling upon Péneios for protection and a change of form. The river god complied, and, covering his daughter with bark and leaves, changed her into the bay tree, and this tree, as we know, was forever sacred to Apolló. The artist of our pail has chosen the moment immediately preceding the metamorphosis for his scene, and has expressed very delicately the ultimate fate of the Nymph by the branches of bay.

prevented his appearance to mankind except in some other form, and he therefore pressed his suit with the chaste Léda in the form of a swan. She, innocently admiring the bird, took it to her breast folding her mantle over it, when the god revealed himself. The fruit of this liaison was the marvelously beautiful Helené of Troy.

Such is the legend which our artist has selected for the third and last scene upon the pail. Like Daphné, Léda is disrobed and occupied with the toilette of the bath. Upon an elevation rests a

little vase filled, we may conjecture, with perfumes or ornaments. Standing upon the back of Erós the god approaches in the form of a swan, and the artist has chosen to represent Léda repulsing him with her hand. The little Erós is showing the young woman a globe, and, if this was intended by the artist to signify to her that the swan was not a simple bird but the god of the universe, it was a most exquisite idea.

The scenes and legends embodied in this piece may not be strictly in accordance with the modern code of ethics, but the art, in which is woven the mythic symbols of the Greek religious creed, is God-given. Could we but appreciate the intense fervor with which Greece (and Rome before her days of dissipation) worshipped the gods and all forms of beauty in art that visibly depicted them, we might recognize at sight the deeper meanings of cosmogony and morality which they symbolized.

(To be continued.)

---

## Proceedings of the Horological Club.

### A DISTINGUISHED BODY OF WATCH AND CLOCK MAKERS.

One hundred and twenty-fifth discussion.—Communicated by the Secretary.

[NOTICE.—Correspondents should write all letters intended for the Club separate from any other business matters, and headed "Secretary of the Horological Club." Direct the envelope to D. H. Hopkinson, Esq. Write only on one side of the paper, state the points briefly, mail as early as possible, as it must be received here not later than the eighth day of the month, in order to be discussed and reported in the CIRCULAR for the next month.

#### POLISHING GRAVERS.

Secretary of Horological Club:

Please inform me how engravers polish their gravers so as to make a clean burnished cut when engraving. I have been told several methods for polishing gravers but none of them seem to come up to just what I want. One way was to put diamantine on a piece of boxwood with alcohol, and after the graver was sharpened draw it over the boxwood. But that seems to take the sharp point off from the graver; the diamantine seems to stick to the point. Another way was to put rotten stone on a piece of sheet brass, and then apply the graver in the same way. But that doesn't seem to work right. I have often seen articles on engraving in THE CIRCULAR, so I take the liberty of writing to you knowing you to be posted on such matters. Hoping to hear from you soon, I remain,  
E. A.

Mr. Expert said the requisites for a smooth cut were a steady, even handling of the graver, holding at the right angle when making curves, and having the edges smooth, fine and sharp. There is no particular way for making them so. Probably it can be done by any of the methods recommended to you. Your trouble doubtless comes from not holding the graver firmly at the proper angle while giving it the final finish, resulting in *rounding off* the edge or points. The polishing must not be allowed to take away from the sharpness, but the faces must be as "square" to the very edges, when polished, as they were before. Possibly you polish *too much*, and the lost keenness is due to that. It is a little difficult to polish a piece perfectly flat, to the extreme edge, with no sign of rounding off, but if you cannot do that it will be better to leave the graver as it comes from a fine, flat oil stone, until practice enables you to get a *polished* flat as perfect as that.

#### CYANIDE OF POTASSIUM FOR CLEANING CLOCKS.

Secretary of Horological Club:

Will the Club please tell me whether or not it is injurious to use cyanide of potassium for cleaning clocks?  
S. W. R.

Mr. McFuzee replied that cyanide of potassium was not fit for "cleaning" clocks. Its use is for removing tarnish and stains and it should be employed after the "cleaning" or removal of the grease and dirt has been done; otherwise there will be a stain of different color at every spot of grease. The pieces should be left in the

cyanide solution only long enough to brighten them up, and they should then be thoroughly washed and rinsed in warm or hot water, for if the slightest bit of cyanide remains it is sure to rust all the steel works. It is difficult to remove it so thoroughly that no trace of it is left, and in most old established shops its use for cleaning is forbidden for that reason. Even the fumes from a dish of it will rust all the steel watch chains and other articles in the neighborhood. When cyanide is used at all it should be kept in the back shop away from the watches and other goods liable to be rusted by it, and the vessel containing it should be kept *tightly* closed. Any neglect on this point will cost you dearly.

It must also be remembered that this is a deadly poison, and not only must not be swallowed, but must not be allowed to get into any sore, cut or other abrasion of the skin. Even smelling of it will make some persons sick.

#### PROCESS OF CLEANING WATCHES IN WATCH FACTORIES.

Secretary of Horological Club:

In looking over the July number of your valuable journal, I find an inquiry from "L" as to "process of cleaning watches in watch factories." Having had some experience during 3 years' employment in the repairing department of one of the leading factories, I herein send you an account of the method there used.

The movement, when taken apart, was placed into a wooden box with separate apartment for plates, dial, each wheel, steel works, screws, etc., balance jewels taken out and all steel work taken off, then carried to a sink where it was dipped into solution of cyanide of potassium, then washed with warm water, soap and brush, then put into alcohol, then dried in boxwood sawdust. Steel works were washed in benzine and dried as before. Balance jewels were washed with alcohol, with stiff brush, and dried in a small chamois skin. The above method was used on both old and new movements, and I would say that I have continued the same plan in my regular business and find it works much better than by using chalk or any other preparation. Would also state that all balances should be trued and poised, hair spring trued and escapement adjusted.  
X. Q. Z.

Mr. Clerkenwell hoped our friend "Z." would write again and more fully. It was not quite clear from his letter whether he placed "all steel work" in the cyanide with the wheels, plates, etc. If so, it was at the risk of leaving some of the cyanide in the screw threads, etc., in which case it would be sure to cause rust of the steel parts. He says afterwards that the steel works were washed in benzine. Was that in place of washing with soap and water or afterwards? He says that balances should be poised, escapements adjusted, etc. He probably meant that it should be done before the cleaning, but does not say so. Why should a *wooden* box be used for dipping into the cyanide solution? It must soak up the solution, which could not be washed out of the wood, but would give off fumes continually to rust the steel work in its vicinity. If it has a separate compartment for each wheel, plates, etc., it must require a large dish of cyanide to dip it into. Does he use such for his private watch repairing business? We should be glad to hear further from him and more in detail, not only about cleaning but also the modes of repairing and other work with which he is familiar as followed in the watch factory. It would be of interest to all watchmakers, who might get valuable hints to follow in their repairing work.

#### WRITING ON WATCH REPAIRING.

Secretary of Horological Club:

I am writing a work on watch repairing, and, as it is my first attempt in that line, I would like to have the opinion of those that are versed in that line. I know of none better qualified in that respect than this honorable body, and knowing your desire to encourage even the humblest of your readers, without ridiculing their attempts, I have made so bold as to inquire of you, if I send on an unrevised and crude sample of my effort in that line, would you pass your judgment upon it and save me any more unnecessary trouble in finishing it? I have written it off-hand in a blank book for convenience, and if I thought it had any real merit I would take great pains with it. If it has not, I would cease at once and save myself valuable time, as I am a poor trade watch repairer and I could put it to better use. Of that, this right honorable body will be the judge.  
S. V. L.

Mr. Horologer said that he had examined the article sent in, and

was convinced that the writer was a good practical workman and understood the subject upon which he wrote. As he had stated that it was crude and unrevised, its literary style could not properly be criticised at this time. The statements or expressions are too general and vague, and the technical terms used are not sufficiently precise. One well acquainted with the subject would understand what was *meant*, but such articles are not intended for that class—only for those who do *not* know. They require to be expressed in language so clear and definite that even the tyro cannot fail to get its meaning, simply because it cannot mean anything else but what the writer intended. Writers seldom appreciate this point fully, unless it happens that they themselves have tried to obtain information from books upon some subject *they* did not understand, and found that the wording would admit of being construed in two or three different ways—and could not tell which would be correct. Generalities may do in oratory, theology or politics, but mechanical treatises cannot be too definite and exact. A most excellent example of clear and precise expression will be found in the famous "Practical Hints on Watch Repairing," by "Excelsior," published in THE CIRCULAR, and are worth studying.

As our friend says this is his first attempt, we would advise him not to undertake too much at first, but write awhile for practice. Let him write short articles upon subjects which he thoroughly understands practically, put them in the best shape he can, make them solid with facts and information and send them to THE CIRCULAR for publication from month to month. The publishers are always glad to receive worthy contributions, and he can soon tell whether writing is his *forte*. When his article is before him "in cold print," he will see it as others do. If it does not suit him he can make the next one better—or, if he cannot, he will see where his weakness is, and, bowing to the inevitable, give it up and devote his time to other pursuits. It is not every good workman who can make a good teacher or writer. But he should not be too easily discouraged. One cannot expect to be fully successful the first time. He must practice at writing the same as at working, and persevere till he succeeds. We hope Mr. L., and all others who are expert in any branch, will give the readers of THE CIRCULAR the benefit of their knowledge, and we shall heartily wish them the same success with the pen as they have had at the bench.

THE NEW STYLE ARITHMETIC.—DIAMOND WEIGHTS OR KARATS

Secretary of Horological Club:

In your interesting answer to my question in your November Proceedings, you ask for the name of the table, etc. I found the table in Orton's Lightning Calculator, by Hoy D. Orton; published by Collins, printer, 705 Jayne St., Philadelphia; copyrighted 1871. He calls it Troy Weight, and says: "By this weight, gold, silver, platina and precious stones, except diamonds, are estimated." (The table comes in here). "Any quantity of gold is supposed to be divided into 24 parts, called *karats*. If pure, it is said to be 24 karats fine; if there be 22 parts of pure gold and 2 parts alloy, it is said to be 22 karats fine. The standard of American coin is  $\frac{9}{10}$  pure gold and is worth \$20.67. What is called the *new standard*, used for watch cases, etc., is 18 karats fine." Then follows the remark about diamond weight. By giving the correct table for weighing diamonds, and its relation, if any, to Troy Weight, you will greatly oblige,

J. B. S.

Mr. Ruby Pin answered that the weight of diamonds is estimated in karats, so there is no occasion to go above that into any particular system of weights. It may be said, however, that the karat is Troy Weight, and the full table, including karats, would be as follows:

*Troy Weight.*

- 4 Grains. . . . . make 1 Karat.
- 24 Grains . . . . . " 1 Pennyweight.
- 20 Dwts. or 480 Grains. . . . . " 1 Ounce.
- 12 Ozs. or 5,760 Grains. . . . . " 1 Pound (lb).

In giving the weight of diamonds, we say it weighs so many karats or such a fraction of a karat, and do not express it either in grains or pennyweights.

In speaking of the fineness of gold, etc., it is usual, in order to

make a distinction between the terms for weight and for quality, to say "karats." He was not aware of any "new standard" of fineness. It is not customary to make watch cases finer than 18 karat, on account of the softness and poor wearing quality of gold finer than that. But that fact does not constitute it a "new standard" any more than 16 karat and 14 karat are "new standards," which they are not, although they are more used than 18 karat. The word karats means simply so many twenty-fourths, *i. e.*, 18 karat means that  $\frac{18}{24}$  of the weight is pure gold. But the word karat, as a weight, indicates an absolute an invariable quantity. The one is a positive weight, while the other merely means a certain *proportion* of whatever weight is spoken of.

So it appears that the new style of arithmetic is operated by "lightning." We might have known that there was something electric about it, for there was a sort of magnetic attraction which caused us to tackle to the idea by instinct. They say everything is going to be run by electricity, and we are glad to see that Mr. Orton has already got the arithmetic reconstructed on the electric system. We intend to adopt it at once as the basis of our financial operations. We cordially approve of the principle and shall hasten to put it in practice. First, we can make  $\frac{1}{2}$  equal to  $\frac{1}{3}$ , then 1 equal to 2, and finally we shall probably be able to add a cypher to the right hand figure without disturbing the equilibrium—then we are made. The whole thing is accomplished by lightning—which means like lightning—or "in a jiffy," as it were. But even suppose it takes as long as a second, we could make 60 turns to the minute, and allowing fifty or a hundred dollars at a clip, it would foot up to quite a respectable figure at the end of the day's work. By industry, perseverance and strict attention to business, together with close economy, frugality and saving, we might hope to realize a handsome competence by the time we were old enough to be laid on the shelf. All we need is to get started once and we are all right. If Mr. S., or any other man, will send us a copy of that invaluable work, we will give him the first \$5 we get out of it, and will bequeath him our seat in the Club when we retire. We also solemnly promise to furnish all the coal the Club requires, so the members will not have to go out so often between the acts to "get warm." This will save them a great deal of trouble and prevent their noses getting so red eating cloves. We hope some kind hearted gentleman will see the gravity of the situation and forward us a copy (post paid) before our next meeting. He will thereby confer a favor upon suffering humanity which can never be repaid, and the heirs to our fortunes shall rise up and call him blessed. N. B.—The number of members is thirteen and each would like a copy.

## Fashions in Jewelry.

### A Lady's Rambles Among the Jewelers.

THE severe simplicity that has characterized feminine attire in the world of fashion the last few years is a thing of the past. Neutral tints have faded before a galaxy of bright hues; soft clinging fabrics modeled to follow the outline of the figure, have given place to stately velvets and showy brocades fashioned over cushions and hoops; the gayest of plumage nods from the Frenchiest of French bonnets and jaunty hats. In a word, a revolution has taken place, quietly but surely, from "elegant simplicity" to "stylish elegance;" a distinction without a difference to most masculine minds, but every woman appreciates the absoluteness of the change. This change means more to the jewelry trade than a casual observer imagines; it means a revival of jewelry in the world of society. Ladies rarely do things by halves, especially in matters pertaining to dress. When that arbitrary mistress called "Fashion" decreed that it was commonplace, even vulgar, to wear long chains, heavy bracelets and

massive brooches, these adornments were banished with other condemned styles. No class of manufacturers appreciate more fully than do the jewelers how loyal the ladies were to the plain mode of dress. The restraint, however, is at last removed, for a redundant style has been introduced, not only by the manufacturers of fabrics and garnitures, but by the modistes, which require for its completeness the richness and glitter of gems and jewelry. Ever since fashion had a history, jewelry has followed as a necessary accessory to pronounced colors and voluminous draperies. The transition from almost no jewelry at all to jewelry *ad libitum* promises to be all the more speedy because every woman possesses an inborn love of finery, and the fact that she has been prohibited for a number of consecutive seasons from freely indulging this inherent taste, gives a keener zest for the revival. This revival, by the way, is being made with unique and beautiful designs, and unusually fine workmanship in all classes of jewelry.

\* \*

\* \*

\* \*

THE manufacturers and designers of gold jewelry have been peculiarly fortunate in the character of the new productions sent out to meet the incoming demand. The new patterns while decidedly unique, are, at the same time, graceful and simple in style. There is an absence of heavy, massive effects, and a decided tendency to association with gems, semi-precious stones, onyx and the like. Enamel has never been employed with more beautiful results than have been gained this season in the fashionable flower patterns where daisies, forget-me-nots, pansies, violets and other flowers are faithfully imitated in size, form and color. These flower patterns appear to decided advantage in the propitiatory "flower-pins," pretty little hybrids between the popular lace pin and the brooch. These flower pins, by the way, afford in their gold petals an appropriate resting place for diamonds and other gems. In illustration may be cited a cluster of daisies which gain the required yellow heart worn in nature by the insertion of a lemon-colored diamond set in the center of each; or, an apple blossom on whose blush-hued lines quiver diamonds like so many dew drops. Bracelets, which are gaining in popularity, are this season attractively made in gold wire or cord, terminating in a single gold flower or a cluster of blossoms with or without the sparkle of gems. Bangle bracelets, always in more or less demand, afford a popular design for the retail trade at large in the padlock pattern. In this the bracelet is a chain of gold, silver or onyx, as the wearer may desire, and fastened with a padlock of similar substance. The padlocks admit of a great diversity of finish, and many of them are incrustated with jewels.

\* \*

\* \*

\* \*

THE hammered or beaten surface in jewelry has been displaced by three styles of finish known as "nugget," "fiber" and "snowflake." The last mentioned is the newest, and all produce a rough surface. Lace pins, sleeve buttons, watch cases and other articles represent these several finishes as well as the plain Roman gold. Popular combinations are gold and platinum, and gold and silver. The former is much employed in gentlemen's fancy vest and the two-pocket chains, match safes, cigar cases, pencils and the like.

\* \*

\* \*

\* \*

THERE is no denying the fact that serious inroads have been made in the sales of the retail jewelry stores, by the tendency of the times towards diversity of stock in dry goods and fancy houses which carry, many of them, large lines of jewelry and silverware. Retail jewelers who have refused to meet the foe on their own ground, and confined their goods to spoons, forks, jewelry, watches and clocks, feel the

effects of the innovation most sorely, and are making complaints of the manufacturers who sell outside the regular trade. These complaints are of no avail; the goods have been made to sell, and when an order comes it will naturally be filled, whether it be from Macy's popular bazaar or Tiffany's world-famed establishment. The safety of each retail jeweler lies in keeping pace with the times, by meeting in his own stock the requirements of the present and growing demand for a diversity of goods. Jewelers who have added *objects d'art* and fantasies as a background and frame work to the legitimate stock of their trade have reported favorable results, and substantiate these reports by carrying more largely each season choice ceramics, artistic bronzes, brasses and other decorative articles. Quite new among specimens of choice pottery are vases and other small objects in Egyptian ware which affords unique effects as regards color and form. Royal Worcester, Crown Derby, Berlin and Vienna fancy goods are included in desirable importations. In Copeland ware come very attractive "creams and sugars" in silver plated stands. Bronzes and fine brasses afford the usual variety of articles; and objects of antique shape in old iron—a recent fancy—are having a run. Novelties in glassware include vases of artistic form and decoration in what is called the cameo glass. Silversmiths have added largely to the list of popular and artistic articles in way of all kinds of gift sets. Their catalogues out for autumn illustrate many novelties which city patrons are selecting from their stocks with a view to the holidays.

\* \*

\* \*

\* \*

THE "Queen" is the newest form of watch chain for ladies' wear, and it has been produced in such a variety of pattern and material as to insure a large patronage. This chain, as most readers are aware, is three or four inches in length and finished with a ball on one end and a swivel for the watch at the other. The watch is worn inside the dress bodice, and the weight of the ball balances and holds it in place. This ball is often made to divide in half in form of a locket or viniagrette. Sometimes a cube or three small balls take the place of the solitary large ball; again, the finish is fanciful, as a teapot of antique shape, or a rosebud. The "Queen" chains come in black onyx, also in silver and with enamel finish. Among oxidized silver chains are those terminating at one end with *fac similes* of ancient coins. These coins, by the way, differ from those introduced on the lace pins last season, in that they are finished on both sides. The fancy vest chain remains the standard watch chain for ladies; the new patterns are, for the most part, exceedingly dainty in design, and embrace both double and single chains. Enameled chains incrustated with gems or semi-precious stones are made to wear with watches similarly decorated; in this connection it may be explained that ladies' watches, as a rule, run in small sizes.

\* \*

\* \*

\* \*

NUMBERED with several articles in gold and silver jewelry, especially adapted for the holiday season, and commending themselves to every retail jeweler's stock by reason of their combination of beauty and utility, are button hooks, charm pencils, match safes, whistles, cigar cutters and bouquet pins. Among the newest designs in the first mentioned are solid gold and silver hooks that close like a knife blade, in an elaborately decorated handle, and others in cases with telescopic movements that produce much longer handles than have been previously made. The latter arrangement is especially recommended to stout people who find buttoning their shoes with a short hook a tedious operation. In pencils for charms the ingenuity of the designer has provided an exceedingly interesting collection. Little jugs, champagne bottles, kittens in a basket, lanterns, bells, balls and other fanciful articles shoot out a pencil point where least expected. Whistle charms used by ladies for the various purposes of arresting

the coachman's attention, calling a pet dog and the like, are this season introduced in gold and platinum with attractive effects. The same may be said for match safes and pencil cases, many of which are exceedingly beautiful. A new and pleasing pattern in these consists in alternate oval bands or rings of gold and platinum. Bouquet pins are out in several sizes to suit the sizes of bouquets worn; these have proven a great convenience and will be in demand so long as natural flowers are worn on the corsage.

\* \*

\* \*

\* \*

THE tiny ribbon pins that so suddenly appeared on every bow knot tied under a lady's chin, have proven such convenient affairs as to insure their reproduction for the fall and winter trade in a great diversity of designs. On these popular pins are represented flies, bees, spiders, dady-long-legs, darning needles and other small specimens from the insect family; also all the small flowers. Very often two of these pins are connected with a gold chain and worn as a neck pin. The newest popular design in gentlemen's scarf pins is the "knot," though star, claw-and-ball, crescent and flower patterns are all desirable.

\* \*

\* \*

\* \*

FINE black onyx jewelry is always more or less worn, and therefore always appears in new and desirable designs. It is *par excellence* the material most sought after by the middle-aged and ladies in mourning. Associated with pearls and diamonds it is attractive to a large class, being an admirable foil to the complexion, and therefore a becoming adornment. In black onyx, this season, are to be found all the new styles in watch chains, bracelets, ear rings, lace pins and other articles that have been produced in gold jewelry. In a word, it is difficult to name any style or ornament worn by ladies that cannot be found in black onyx. For mourning purposes the usual plain finish gives place, in many instances, to what is variously termed the dead satin and crape finish. Popular articles in black onyx jewelry are, at the present time, bracelets made in sectional pieces, and set with diamonds and pearls; shawl and lace pins in unique design; the queen chain and hoop ear rings, on the front edge of which appears a solitary pearl or diamond. An article in black onyx for which there is always a steady sale is the memorial or widow's locket. This is often made with an elaborate setting of pearls and diamonds; again, it is as plain as possible, to be worn suspended from a slender chain under the dress and quite out of sight.

\* \*

\* \*

\* \*

HERMATITE has this season been successfully introduced on lace pins, ear rings, scarf pins and other articles of gold jewelry. The spherical shapes of this mineral with every movement present varying shades of color in concentric bands, from very dark brown to black, after the manner of black pearls, which they closely resemble. These little balls are carefully mounted in clamp settings, the same as are diamonds and pearls, and afford novel and elegant ornaments at a comparatively small price. Hermatite jewelry promises to have a long and successful run, judging from the attention it is at present attracting.

\* \*

\* \*

\* \*

NO LADY, nowadays, considers her collection of accessories to the toilette complete without one or two scent bottles and viniagrettes. Indeed, to be *a la mode* she must have an assortment of receptacles for aromatic vinegars, atter of rose, eau de cologne and smelling

salts, for she wears one to church and another to the opera; to confuse these would be as disastrous as a transfer of prayer book and lorgnette. Conspicuous in this assortment is that cumbersome freak of fashion, the cut glass cologne bottle with gold or silver cap, measuring all the way from six or eight inches to a foot and a half in length. These monster bottles owe their speedily gained popularity in polite society to the fact that they are *outré* as regards both appearance and cost—a sure passport to a desirable class of patrons. A full dress toilette for the opera is not complete without one of these scent bottles, which is carried in a long plush bag drawn at the top on a cord with tassels. The newest models in these cologne bottles represent fish, snakes, horns and other irregular shapes; they are also manufactured in sterling silver and fine ceramics. Passing from one extreme to another, is the tiny glove viniagrette worn under the glove in the palm of the hand; for this style there is a large and steady sale. Other popular designs are the gold and silver viniagrettes suspended from a chain to be worn at the side, and the minute viniagrette charms for watch chains.

\* \*

\* \*

\* \*

THERE no longer remains any reason why everybody should not take note of time as it passes. The importers and manufacturers of dials and clocks have certainly afforded in their stocks this season a sufficient variety of timepieces to accommodate the most fastidious in regard to accurate timekeepers in decorative form, and the most impecunious as regards the cost of clocks. The flying pendulum clock is counted with novelties. The clocks with chimes and cathedral gong strikes are attracting universal attention. Just now jobbers are busy picking up odd things for the holiday trade in clocks in padlock form, owls, stars, scrolls, barrels and other queer shapes.

\* \*

\* \*

\* \*

FOR rare gems there is always a demand; this fluctuates, it is true, as money is more or less plentiful in the country, but it never ceases. Unlike other personal ornaments, therefore, precious stones are ever in fashion. The style of mounting them varies with recurring seasons, and the association of colors changes to satisfy certain requirements of fashion, but the jewels are worn, in one way or another, from year to year, no matter what form of bonnet or dress the Princess of Wales chances to render popular by her patronage. Perfect rubies, emeralds and diamonds of desirable size are becoming scarcer, and consequently more costly to the importers every year. As yet, this increase of value has not affected prices with retail buyers, who find them about the same as last season. Scarcity insures to fine gems a certain money value for all time to come, and renders them a safe investment even in "hard times." The owners of desirable jewels, therefore, enjoy the double satisfaction of possessing in snug, compact form, elegant ornaments and a little fortune. The present fashion in gems tends decidedly to an exhibition of the gems pure and simple; the setting being subordinate; indeed, when practicable, not showing at all. The intrinsic worth of an ornament is usually concentrated in one object, as a flawless diamond in the center of a pendant and worth \$10,000, suspended from a slender gold neck chain that did not cost over \$25. Fine gems for ladies wear, are, as a rule, set high with as little of the setting in view as is practicable. The pendant is a favorite form for wearing precious stones, the value—as has already been intimated—being chiefly concentrated in the center of the piece. These ornaments, by the by, are made in many instances to wear in a variety of ways, as a neck pin, a finish to a bracelet, or in a pin for the hair. There is a growing demand for pearl necklaces; in these ornaments the pearls are strung on silk threads like so many beads, presenting on the neck a simple strand of pearls. Single stone necklaces are also in favor;

those composed of small diamonds being specially sought after. In these the stones are mounted so that no gold is visible. Fine gems for gentlemen's wear, notably in rings, are embedded in a comparative massive setting. Small stones are also embedded with pleasing effect in the decoration of watches, lace pins, sleeve buttons and articles showing Indian chasing, rococo and other rough surface finish. The sapphire is at the present time one of the most popular of gems; this is largely due to the fact that they are exceedingly plentiful, and therefore correspondingly reasonable in cost. The favor with which colored gems is regarded the world over cannot be more significantly illustrated than was done the other day at a wedding in high life in England, where, contrary to all tradition, the bride wore colored jewels.

\* \*

\* \*

\* \*

MANUFACTURERS and importers, in the face of a doubtful season, have assumed large risks by putting on the market in all departments pertaining to ladies' attire, an attractive and extended line of novelties. The truth of this statement as regards dry goods and millinery is substantiated in the show windows, and on the tables and counters of our leading retail houses, where goods are displayed with a view to catching and holding the eye of every passer by. Many of these houses consider an attractive arrangement of stock of so much importance that they employ on large salaries men of artistic taste and quick perception, for the sole purpose of dressing their windows and cases. As a rule, it may be claimed that a profitable percentage of the number who pause before a show window to admire enter the house to buy. Now, the manufacturers and importers of gems, jewelry, silverware and *objects d'art*, are not at all behind hand in way of novelties, striking and beautiful, but the retail trade fails, in some instances, to make the best exhibit of these various articles. Gold and fancy jewelry, spoons, forks and gems crowded into one window, regardless of harmony in design, color or value, produce a chaotic picture as a whole, and lose individuality to the several departments represented. There are beautiful specimens in this mixed collection but their value is dwarfed by the near presence of numerous commonplace articles. The assistance to quick sales of attractive windows and show cases is second only to a clever salesman; the first arrests the customer, the second persuades him to empty his pocketbook. Without the arrest, the salesman—no matter how well versed in his business—has lost a golden opportunity.

\* \*

\* \*

\* \*

A RICH background of contrasting color, when judiciously selected, adds greatly to the effectiveness of both jewelry and silverware. A pretty plush or morocco case, with what is termed the popular trade, is an important factor in a sale. This is notably true with gift articles, such as holiday, birthday and anniversary presents. An article of comparatively small value even gains a decided importance with the average buyer when presented on a velvet cushion or satin lining. In this connection may be appropriately mentioned the pleasing variety of styles in new show cases, window trays, ring bars, cases for jewelry, silver and the like. In the celluloid cases have been gained exceedingly satisfactory results in ebony, tortoise shell, agate and other effects. Trays for rings have taken on fancy forms, such as scrolls, stars, horseshoes and crescents. Jewelry boxes and toilet cases in diversified patterns afford attractive articles for the retail jeweler's stock. So do the new escreteires containing wax tapers, tiny candlesticks of antique shape, a seal and sticks of colored

sealing wax. These escreteires promise to be popular holiday articles, for they not only meet the requirements of the present fancy for sealing with wax and stamping a letter, but are manufactured in a sufficient number of grades to give a wide range in prices.

ELSIE BEE.

### Tenth Annual Dinner of the New York Jewelers' Association.

THE ANNUAL dinner of the New York Jewelers' Association at Delmonico's in the fall of each year is regarded as one of the principal social events of the season. The Association is composed of the representative manufacturers in the trade, and the aggregation of wealth invested in manufacturing by its members is considerable, being greater probably than is represented in any other trade association in the country. On Thursday night, November 13, the tenth annual dinner of the Association was given at Delmonico's, and in all respects it was equal in elegance and brilliancy to any of the dinners in preceding years. In this re-union of practical business men who come together each year, and, throwing aside business rivalries and asperities, devote their attention for an evening to the cultivation of pleasanter relations, much substantial good results to the Association of Jewelers as an organization, to the members individually, and to the entire trade in general.

At half-past six a suite of Delmonico's best reception rooms was thrown open to receive the assembling jewelers and their invited guests. Among the guests who came were gentlemen distinguished in the judiciary, in government, at the bar and in literary and artistic pursuits. At seven o'clock the committee having the affair in charge escorted the banqueters into the dining hall. Within the banquet room all was a scene of exquisite brilliancy and magnificence. The decorations were elaborate, floral and silver embellishments in abundance beautified the five tables that were spread, four being at right angles to the fifth, which was elevated and occupied by the President of the Association and the speakers of the evening. From the balcony above familiar operatic airs were played by the band engaged by the Association, and floods of light from countless chandeliers and candelabra lent magnificent brilliancy to a fairy-like scene. Flags in variety were hung about the walls of the hall in artistic arrangement, with the national shield below each group of flags, and facing the entrance and directly over the head of the President was a handsome representation of the national emblem, presenting a towering and life-like spread eagle. Tropical palms of rare and superb variety were placed about in convenient corners, and delicate flowers and emblematical designs added charm to the banquet tables. Roses, chrysanthemums, pinks and a variety of other fragrant cut flowers pleased the eye of the diners and tended to increase the appetite for the substantial and delicacies about to be served. The flowers were provided by the Association, and not, as is customarily done, by Delmonico. The silver decorations on the tables attracted much attention and were very beautiful and elaborate. The metal was of the true quality, some of the pieces were valued at a thousand dollars a piece, and the entire decorations were furnished by the Gorham Manufacturing Company. The gentlemen having the affair in charge did themselves honor, and their efforts were fully rewarded by the effect. The urbane Secretary of the Association, Mr. H. Olmsted, was untiring in his efforts to assist in every possible way to make the dinner a success, and due appreciation was shown for his courtesies. The company were escorted to their seats, each one of which was designated by an artistic card bearing the occupant's name. The *menu* cards were backed on various colored grograin silks, with red, white and blue decorative ribbons; they were the most handsome *menus* the Association has had at any dinner. Before the dinner began, the President, Mr. W. R. Alling, called on Rev. J. H. Rylance, of St. Mark's Church, to invoke the blessing of



God, while the gentlemen present bowed their heads. The guests being seated the dinner was served. Following is the *menu*:

## MENU

|                                   |                                  |                      |
|-----------------------------------|----------------------------------|----------------------|
| Huitres                           |                                  |                      |
| POTAGES                           |                                  |                      |
| Consommé Deslignac                |                                  | Crème de volaille    |
| Olives                            | HORS D'ŒUVRE                     | Radis                |
|                                   | Bouchées à la Turbigo            |                      |
|                                   | POISSON                          |                      |
|                                   | Bass rayée à la Rouennaise       |                      |
|                                   | Ponime de terre à la Hanovrienne |                      |
|                                   | RELEVÉ                           |                      |
|                                   | Filet de bœuf à la Vendôme       |                      |
|                                   | Epinards à l'Espagnole           |                      |
|                                   | ENTREES                          |                      |
| Poulardes braisées à la Lyonnaise |                                  |                      |
| Petits pois Français              |                                  |                      |
| Côtelletes de grouses à la Segard |                                  |                      |
| Haricots verts panachés           |                                  |                      |
| Ris de reu au Chancelier          |                                  |                      |
| Choux-fleurs au gratin            |                                  |                      |
|                                   | SORBET                           |                      |
|                                   | à la Régence                     |                      |
|                                   | ROTI                             |                      |
| Perdreaux                         |                                  | Salad de laitue      |
|                                   | Extremets Sucrés                 |                      |
|                                   | Pouding à la Bagration           |                      |
| Gelée pistaches, Orientale        |                                  | Meringues à la crème |
|                                   | DESSERT                          |                      |
| Glaces Napolitaine                |                                  | Biscuit Rivoli       |
| Fruits                            | Petits fours                     | Cafe                 |
|                                   | VINS                             |                      |
| Haut Sauterne                     | Sherry                           | Pontet Canet         |
| Cliquot sec.                      |                                  | Pommard              |

Le 13 November, 1884

DELMONICOS.

The following named gentlemen were the guests invited by the Association and who responded to the toasts, their names being given in the order in which they sat from right to left, the President occupying the presiding chair in the center of the line:

## ASSOCIATION GUESTS.

Hon. Chauncey M. Depew, Chief Justice Noah Davis, Mayor Low, President W. R. Alling, Rev. J. H. Rylance, D. D., Colonel Charles H. Gibson, Hon. Algernon S. Sullivan, and J. Seaver Page, Esq.

The following is a complete list of the members of the Association and the guests of members that were present at the banquet:

## MEMBERS AND GUESTS.

*From New York*—A. Carter, Jr., H. S. Cozzens, J. S. Franklin, Geo. R. Howe, C. E. Hastings, Geo. B. Jaques, Thos. Le Boutillier, B. H. Knapp, J. H. Johnston, J. C. Aikin, Jos. Fahys, J. F. Chatellier, Jas. Hedges, Geo. A. French, J. C. Mount, H. C. Ostrander, J. P. Snow, J. B. Bowden, J. R. Greason, W. H. Atwater, Geo. S. Brown, A. J. G. Hodenpyl, Geo. H. Hodenpyl, L. L. Woolley, E. J. Scofield, S. E. Thomas, W. T. Woodruff, C. H. Brahe, N. H. White, C. G. Alford, Wm. R. Alling, W. B. Kerr, Jno. D. Alling, F. S. Douglas, Alfred H. Smith, Geo. M. Hard, W. B. Durand, C. F. Greene, Thos. G. Brown, Horace S. Woodbury, Louis C. Nash, Wm. F. Michael, Andrew C. Craig, Jr., H. B. Beach, C. E. Breckinridge, D. C. Dodd, Jr., Chas. Fellows, J. T. Scott, B. K. Hills, Irving Smith, W. G. Appleton, D. F. Appleton, Geo. Wilkinson, W. C. Spencer, E. Holbrook, J. W. Beacham, Geo. C. White, Jr., R. N. Petersen, G. T. Woglom, Mr. Newell, L. B. Haff, H. B. Dominick, Hiram W. Brown, A. Dominick, S. W. Hale, H. Olmsted, S. S. Battin, Jr. *From Washington*—M. W. Galt, H. Semken. *From Philadelphia*—Geo. W. Banks, O. S. Hamrick, C. Weaver, J. A. Caldwell. *From New Haven*—Gen. Geo. H. Ford, A. O. Jennings, F. B. Jennings, W. H. Stevens, M. Jennings. *From Boston*—Geo. H. Richards, Jr., Mr. Low, of Shreve, Crump & Low. *From Providence*—Henry Tilden, Jr., H. B. Houston, Geo. H. Houghton. *From Other Cities*—S. B. Sandford, Troy; J. G. Bacon, Meriden; J. H. Hart, Brooklyn; F. M. Lewis, J. S. MacDonald, Baltimore; A. O. Headley, Newark.

The viands and wine accompaniments were discussed from seven to about nine o'clock, when coffee and cigars were served and the toast speeches began.

Following was the address of President W. R. Alling to the Association:

## ADDRESS OF PRESIDENT ALLING.

*Fellow Members of the New York Jewelers' Association:*

You did me the honor two months ago to elect me your President, and, as I have not seen many of you since that time, I wish to return my thanks for the honor conferred on one so unworthy to occupy the highest place in our trade.

I wish to congratulate you on this, our 10th annual dinner, and hope you and our guests have enjoyed the good things Delmonico has provided, and are in a happy state of mind to listen to the brilliant speeches from some of our friends on my right and left.

The 10th anniversary is generally known as the tin wedding. But as tin would be out of place in this assemblage of dealers in diamonds, watches and costly goods, one of our members has kindly decorated our tables with some of the most artistic silverware manufactured.

Now, I am not going to detain you with any review or statistics of our Association, but merely to allude to our continued prosperity, and to congratulate you on the fact that death has not entered our number during the past year, and although these cannot be called prosperous times, still we have seen much worse, and have every reason to be thankful that we can again meet and exchange pleasant greetings with old and new friends.

I cannot make any lengthy speech this evening, as you all know speech-making is not my forte, and I would only be consuming the time that would be occupied by such orators as grace this table.

In the early part of the day preceding the evening of the banquet President Alling unfortunately was prostrated by sickness, an attack of acute dyspepsia. He recovered sufficiently toward evening to be induced to attend the dinner and occupy the President's chair at the table, but as the evening progressed his condition again grew worse, and, finding himself unable to enter heartily into the festivities of the evening, he decided to retire, and, later, to go home, notwithstanding the urgent effort of his fellow members and friends to persuade him to stay, a feeling which afterward gave way to genuine sympathy for the sickness of their President.

At a little after nine o'clock, one of the old Presidents, Mr. D. F. Appleton, who had been requested to take Mr. Alling's place, rapping his gavel on the table, called the assemblage to silence. He then addressed the company:

## INTRODUCTORY REMARKS OF MR. APPLETON.

*Gentlemen:*

I am very sorry to say that the President, Mr. Alling, is indisposed, and I am requested by the Vice-President of the Association to take his place here temporarily. I sincerely hope that he will soon be able to resume his place here.

I find on Mr. Alling's memorandum that the first regular toast of the evening is,

*"The President of the United States,"*

and I ask you to fill your glasses and drink to the health of the President of the United States, (Cries from the audience: "Who is the President of the United States?") the Honorable Chester A. Arthur. Your President has made a memorandum to call on the Honorable Chauncey M. Depew to respond to this toast.

Mr. Depew spoke as follows:

## ADDRESS OF CHAUNCEY M. DEPEW.

*Mr. President and Gentlemen:*

About thirty minutes since the President of the Association came to me and stated that neither the President of the United States was here, nor the Mayor of the city of New York, who had promised to respond if the President could not, and asked me to respond for the President or the Mayor. I said yes, if wanted to respond to one of these toasts I would prefer to speak for the Mayor of this city. With that peculiarity in the jeweler mind which makes the ordinary practitioner in that business go contrary to what anybody else wants, he immediately appointed me to the other place. Now I have been speaking on the President of the United States for about six months, and it occurred to me, when he arbitrarily made that decision, that he wanted that speech that I have been delivering during the recent campaign. I could condense it into two hours and a half, but I do not propose to deliver it to-night. (Sighs throughout the room). Your sighs of relief gratify me. The question naturally recurs to me which president am I to respond for. (Laughter). I certainly cannot meet this question, with Sulli-

van present, with all the fairness and judicial discrimination that the case demands; and I think that there is no one probably in this community to whom the Jewelers' Association are under greater obligations in this presidential subject than they are to Sullivan. I do not mean that Sullivan's efforts elected Cleveland, (Loud applause and three cheers for Cleveland) but what I do mean is this: On the Thursday night following the election there appeared in the Democratic newspapers of the city of New York a call for the Cleveland and Hendricks clubs to meet at Wall street the next day for the purpose of hanging the newspapers that claimed Blaine's election. (Laughter). Mr. Sullivan prevented that riot by remarking to his assembled associates that while it may be proper to hang a candidate who had violated his sworn duty, to hang a newspaper man who was printing the facts as he heard them was something in his judgment that the present condition of the Democratic party could not stand. (Laughter). Now, as all rioters, after hanging the people they have in view, immediately proceed to loot the jewelers' houses and the silversmiths' quarters, the fact that a jewelry establishment remains in the city of New York is due to Sullivan, and hereafter, when any of us purchase any of your manufactures, we expect to see on the bottom of it "S. S.," "Savior Sullivan." (Laughter and applause).

Now there is a peculiarity about dinners of this character that the first one is always the best and is looked back to with more eagerness, for the reason that the narrow range of the topics that can best be discussed cause a repetition of the same illustrations year after year, and there is a peculiarity about the human mind, even the jeweler mind, that the best things said, after a while, fail the appetite, and I know of nothing that has such longevity as an apt application that is always applicable. I remember when Chicago was burned down, at the first public meeting some distinguished man made a reputation by speaking of "the Phœnix rising from her own ashes." It was a happy thought. While it occurred to him, it occurred to every other man in the United States, but he had the first chance to get it off. Every other orator thereafter got it off, not knowing that it had been repeated before, until, when any one went to Chicago thereafter, his friends had to advise him not to mention the Phœnix, unless he wished to be assisted to climb the golden stairs.

While the jewelers are, so far as I know, a pious people, I know, however, that whatever their presidential candidates were, none of them were for St. John, because I have been flooded with every liquor known to the still to-night and Apollinaris I could not get. (Laughter).

But to return to what I was remarking, the sacred gentleman who wrote the beautiful sentiment about the golden stairs must have been a jeweler, because every jeweler I have ever met managed somehow or other to make a delicate allusion to his place of business. (Laughter). I said to the gentleman beside me to-night: "This is a beautiful dinner, and I never saw anything more handsome than these table decorations." He said: "Yes, the Gorham manufactory contributed these things. Each of them are worth a thousand dollars. The trade are always pleased to have them upon the table, and they are recognized universally as the very best evidence of the jewelers' art in the world." I said: "My dear friend, who are you?" He said: "I am the agent of the company." (Laughter and applause. The joke was at the expense of Mr. Holbrook, the agent of the Gorham Company, who was present and occupied a seat at one of the lower tables and who had not been near Mr. Depew's seat).

Well, now, gentlemen, in all seriousness, there is only one organization that I know of that is free of this constant recourse to the same topics, and that is the New England Society, of which my friend, Appleton, is one of the distinguished officers, and the reason for this is that the New England sons claim that all there is in this world come from them, so that there is nothing in the broad range of human achievement that the New England Society cannot talk about with propriety. (Laughter).

We have, in this presidential election, some of us been frightfully disappointed and some of us have been pleased. Both parties claim that the election has settled everything, and each have their own view of what has been settled. One party thinks it has settled the country so decisively that it will never rise, (Laughter) and the other party thinks it has settled the country for a glorious future. (Laughter and applause). There is one thing which it has settled, and that is a question that has agitated the public mind for the last twenty-five years, and it is now settled beyond dispute forever, and that is the propriety of the clergyman interfering with politics. (Loud applause and laughter). It has settled another question. There is no surer, bolder and sharper man than the political manager. But this election has settled the question that there is one thing the political manager does not understand, and that is, the effect of the Delmonico dinner. (Continued laughter).

But to be serious again, I have the profoundest faith in the elasticity and growth and future strength and power of the American people and the American Republic. While I firmly believe that they would be better and stronger and more gloriously great under a Republican dispensation, still I have the profoundest faith that they can stand whatever the other fellows believe in. And from my standpoint, speaking for the President of the United States, and on this question now agitating the public mind—from my standpoint, I desire to say that if Governor Cleveland should be declared President of the United States, as I think he will be, (Applause) I can submit to the inevitable with great grace. He has before him a quarter of a century of Republican Presidents. If he is equal to the poorest of them he will receive my respect; (Laughter) if he is equal to the best of them he shall have my support. (Applause).

But I remember, gentlemen, you are gathered here to-night as the Jewelers' Association. When I was in London last summer I went into a street of old London two hundred and fifty years ago, and the most interesting part of what I saw were the various guilds practicing their business in the uniform of the dress occasions of the guilds of olden period. I inquired into these guilds and I found that the jewelers' guilds of to-day have not a single old jeweler in them. They have all become peers, British lords. I know of no House of Lords in this country except the jewelers. (Laughter). I would like to know what profession we have that represents the tempter of womankind better than the jewelers of this country. (Laughter). We lawyers make it our business to study human nature for the purpose of capturing, by the manner in which we present our case, the jury and the court. But we yield, in our knowledge of human nature, to the ordinary jeweler. The manner in which an ordinary jeweler will hold up, before a lady he knows can pay for it, a diamond necklace, surpasses anything in the knowledge of human nature. The manner in which an ordinary jeweler will take—and the extraordinary ones can do anything—I am now speaking of the ordinary common kind—there are none of those here to-night—the manner in which the ordinary jeweler will take a parvenu who has just struck a fortune and who is in search of wonderful things, present to him the evidence of antique art in his establishment, and make him believe that, by the proper amount of purchases, he cannot but gratify his natural taste for the beautiful, surpasses anything in the line of human capture that is known to those elements that prey upon the human kind. (Laughter).

And now, gentlemen, laying aside politics and laying aside the shop, I want to say, finally, that the world owes to you a debt which it is my part to stand here and voice. It is true that our profession gets out of you nothing that we do not pay for except this annual dinner (Laughter); but we have no grudge against you for that, and I want to say, in all seriousness, that there is nothing that is recognized in this world, at this day, more than the fact that the world is better now than it has been, and that civilization is more pronounced, and that blessings are more generally distributed, and all is due to the fact that the artistic mind has been so cultivated, that art has gone down to the lowest walks in life. There is in this country no house so plain, no cottage so simple, that you do not find on its exterior or in its interior some sort of artistic cultivation which elevates the man above the level of the brute and makes him a better citizen and tends to maintain a stronger government. There is no business that we have to deal with that so caters to the beauties of art that we meet with in the domestic uses than that of the jewelers. (Applause).

MR. APPLETON—I regret very much that Mr. Alling has not made his appearance. I find a memorandum made that the second toast is one to which you will listen with a great deal of pleasure and pride. The toast is:

*"The Mayor of New York; Chief of this Imperial City, second only in responsibility to the head of this nation."*

I know we will listen to this toast with gratification for the health of the gentleman who is toasted. The honored Mayor of the city is not present, and I think we ought to drink to his health as at the head of this city, which the toast calls for. We are very fond of this city, standing as she does grand and glorious in her imperial eminence above all other cities on this continent, and, progressing as she has, giving us certainty that she will, before long, be the chief commercial city of the world. I think we, as a trade association, ought to dwell more upon this subject and express oftener our pride in the grand city of New York. Fill your glasses and drink, gentlemen, to the health of the Mayor of New York, who is unavoidably absent to-night, I am told.

After the toast had been drunk Mr. Appleton continued:—Now we

cannot all live in New York, and that leads us to think of that city which is, in all respects excepting in its municipal organization, a part of the city of New York, and it is with great pleasure that I propose the health of the distinguished and honored Mayor of the city of Brooklyn, and I will ask you to drink to the health of Mayor Low, who is with us to-night. (Three cheers for Mayor Low were given).

Mayor Low responded to the toast as follows:

ADDRESS OF MAYOR SETH LOW.

*Mr. Chairman and Gentlemen:*

When I received your invitation to be present I had just read the address of James Russell Lowell upon the Democracy, wherein he stated that events had proved singularly regardful of the recognition of prophets, and I could not but think how fortunate it was that the brilliant anticipations of Colonel Sellers had not all been true. You will remember in one of those prophecies of Colonel Sellers he said that for a side speculation he proposed to invest in hogs, and that he and his friends would lock them up until hogs should be jewels. I do not know whether it was in anticipation of that prophecy that your craft has imitated the original animal and made him popular, but certainly I am glad that it was not true. I feel embarrassed, speaking for the city of Brooklyn, until I have heard what the Mayor of New York could say about your own city. The last time I had the pleasure of meeting him at a dinner he suggested that the city of Brooklyn should be joined to the first ward of New York, and I illustrated to him the terms upon which such a compact may be made. I pointed out to him that you never heard of the New York Bridge: it is always the Brooklyn Bridge. If the time ever comes when the two cities join, farewell to New York. Therefore, you can understand that there is a very slight step from such a subject to undertaking to say a word or two in regard to the city of which I am Mayor, and perhaps I ought to first illustrate the leading thought, in the terms of your trade. To my conception, New York is to Brooklyn as the pendant that hangs on the neck of some fair dame. (Applause). If you will look at the Bridge on any night and see the brilliancy of the lights, you will naturally conceive, I am sure, that something very brilliant must be the rare jewel that culminates the chain.

But, gentlemen, when you have responded to the toast of your city on every occasion through a single term, whatever ambition you may have to serve the city a second term, you certainly could wish that at public dinners that toast might be eliminated. (Laughter). I shall not, therefore, dilate on this subject this evening, for indeed, in attempting to do justice to the city of Brooklyn in a single evening would be an impossible task. On great occasions the city of Brooklyn speaks for herself. Nevertheless I do feel to-night like acknowledging the compliment that was implied by hailing us as a sister city, for in view of what took place last week we must be one of the graces. I believe there are three graces altogether: New York being one and Brooklyn the second, and I have a little doubt in my mind whether the third is Long Island City or Jersey City. (Laughter). I rather incline to the latter, partly because I believe the President of the Jewelers' Association is a Jerseyman.

I am not well enough up in the jewelers' art to make such touching allusions to what it can do, as the gentleman who responded to the toast of the President of the United States, but I am reminded of a singular mistake that Providence or some other cause has made when I reflect that Brooklyn is the headquarters admittedly of the sugar industry, of the oil industry and of other businesses, and I have wondered why it is that the jewelers' art does not also find its home in Brooklyn. I only know, though, that we have the heart of the trade there, (Laughter and applause) and I suppose that we ought not to begrudge to the city of New York the head, or even the city of Newark where, I understand, the real head for the moment does reside. (Laughter). I thank you, gentlemen, cordially for your courtesy and for your dinner, and I wish to the Jewelers' Association all prosperity.

MR. APPLETON—Gentlemen, I ask you to give your intention to the next regular toast:

*"Our Western States."*

This will be responded to by a western man who was born and bread in the Hoosier State, and I will be very glad to follow the suggestions made on this memorandum and call upon a very old friend of ours; we are always glad to see him; I refer to the Honorable Algernon S. Sullivan.

Mr. Sullivan was received with repeated cheers and spoke to the toast as follows:

ADDRESS OF ALGERNON S. SULLIVAN.

*Gentlemen:*

You must not take up too much of my time. I understand we have been allowed only seven minutes to speak, and Mr. Depew used up the time that was to be divided between the rest of us.

I want at once in responding to this toast, while Mr. Alling is absent from the room, to make a special response which I think that he had in view in framing that toast, and for which I am not sorry he intended to apply to me. I wish to speak to you as his neighbors in trade about him. Mr. Alling and I were born in the little Hoosier village, Madison, Indiana. I am one of those who always intend to carry a western heart until it is laid away cold, (Applause) and for one reason, and that is, that I wonder if there is a place in the world in which the attachments are more lasting than were the attachments that were formed between the boys who were schoolmates and friends in that region in which we were born, which was then more decidedly frontier than it is to-day at any points between here and the Pacific shore. I am glad to recall to-night the vision of the little square brick house at the end of what was called Main street in a little village, prettily situated at the end of a high hill, where she, whom everybody admired, whom everybody respected and loved for all the virtues that adorn womanhood, whom everybody esteemed for that which was a perfect example of the Christian widow, such qualities were associated with the name of Mrs. Alling, the mother of your President. (Applause). There is no tradition of that little town that is cherished with more pleasure than the recollection of that little home and the life of that pure widow, with her noble struggles to rear a large family of little children. That is the image of that little Alling home, and it was with great delight when I received this toast to know that it had been prompted by the friend of my boyhood. He has encouraged and cherished those principles taught him that make fine men and useful citizens. This is a tribute that has come from the heart of one who is happy and proud to speak of Mr. Alling as his life-long friend. (Applause).

The toasts that have been given has brought to mind necessarily again the subject which all of us have been so anxious to forget, and singularly enough the President and the Mayor came first in the arrangement of toasts, and you may not be able at once to see why and how, and it is my privilege to tell you. It has come about that every mayor now in the United States expects by natural progression to come next to the governorship and next to the Presidency, especially the reform mayors (Laughter at Mayor Low's expense); especially those who recognize thoroughly and believe in civil service reform, and especially those who have tact and a knowledge of human nature. Now, Mr. President and gentlemen, in referring to the presidential subject, it was just as well if my friend, Mr. Depew, had recognized that the real source of the exultation with some of us—what I believe after all is the sober satisfaction, and contentment, and placidity which is settling down upon all the community—is that there was a desire to have that which was promised—a redemption of promises to the country. Nothing that can be said on an occasion like this can be understood more than the views that within the limits of good taste and pleasantry serve to show good fellowship after a period of great excitement. One thing I say has been demonstrated, and that is, whatever has been promised must and will be fulfilled to the people of the United States or else they will know the reason why, and we understand now that whatever has been promised must be fulfilled, or else there will come wisely, and properly, and justly, a day of recompense and a day of change again. (Applause). For one I can say that if the promise be not fulfilled, if the hope be not realized, then it must not long be when the change shall come again. (Continued applause). Now, we all know that it is very easy to make promises, and a great many promises are made that after all are not made by those who have the intention or power to fulfill them. I am reminded while I say that about an anecdote told by a friend of mine who, having been a planter and owned a plantation, when slavery was abolished, called his slaves together and said to them: "Let us occupy this land together, cultivate it and divide the profits." He told me that one day going out from his house and passing down by a cabin toward the woods, when he came near to a lane, he saw a colored woman coming and carrying on her head what he thought was a bundle of firewood that sank her down under its weight. And just when he was about to meet her he saw another colored woman, and when the two girls came within reach, one said to the other: "Dam you nigger! who tole you to fetch dat iron frum de cabin." And the other retorted, "O, de Lord! woman, Massa Depew tole me." "Why, you fool nigger," said the first, "dun you know Massa Depew can't be trusted." (Laughter). Now, the lesson is, that we must have promises only from the mouths of those who can be relied upon.

The last time I saw the jewelers was not at dinner. I heard the reverend

neighbor on my right remark upon the very fine appearance of the jewelers here to-night. (Laughter). He, perhaps, did not have the pleasure of seeing them as I saw them last. Gilmore's band was at their head, and as they marched along in the great procession they were the admiration of all. Every window on Broadway was occupied by handsome women. Flags were flying and hands were clapping; and the best looking fellows, the most smiling, the most obstreperous and deliciously noisy section of the grand procession that moved up Broadway, New York, several days ago, was the jewelers. The coroners have been busy holding inquests ever since over the fair women that were smitten, and who could not get down to the street fast enough to where the jewelers were. (Laughter and applause). It seems to me in that procession on that bright afternoon that they were so numerous, and they were all carrying their consciences with them, and I never so frantically saluted by elevating my hat as I did on that occasion. (Applause).

I hope, gentlemen, that it will at some time be a pleasure to you as great as it has been to me to-night, to join in festive assemblies with your own trade or others, and that you will have the fortune of meeting with old friends so that everything shall recall to you the pleasant, the happy days of your boyhood as it has to me to-night.

MR. APPLETON—I find put down for the next regular toast the following:

*"Our Friends who have honored us with their presence this evening."*

It used to be said that you cannot get along without clergymen. Some of us have thought lately that we could have gotten along just as well without them, (Laughter) but we must consider that as something out of the ordinary course of things, and resume the old notion, especially as this evening we have with us one who is discreet as well as learned and eloquent, and I am sure, while he will instruct and entertain us, will not make any trouble. I have the pleasure of calling upon the Rev. Dr. Rylance. (Applause).

Dr. Rylance responded:

ADDRESS OF THE REV. J. H. RYLANCE, D. D.

*Mr. Chairman and Gentlemen:*

If the process of subtraction has been going on since Mr. Sullivan began there cannot be more than a few moments left for me to speak. I can only have about two minutes. It was I that uttered the reflection privately—it was I who made the observation as to the beautiful and healthy men before me. You cannot make much of men who are not physically strong. There must be health as a substratum for work.

When I received your invitation to come and be one of your company, I hesitated for a moment because I belong to the orthodox calling of my profession (though the *Saturday Review* has recently taken me to task because of my loose sentiments), but I am orthodox enough to have scruples about departing from apostolic revelation, and my orthodox instruction embraces this: that women should not decorate themselves with gold, and when I received your invitation and thought of this, I said to myself: How can parsons reconcile themselves with jewelers—reconcile the instructions of St. Peter with the temptations offered by jewelers for women to do this? Well, of course, I have managed to reason around that by remembering that historic christianity has a great deal that was time-serving; that is to say, things that were wise and prudent and fitted for the time and occasion. For you remember what restraints were placed on christian women in the early days of christianity. Long ago it was necessary for christian women to separate themselves visibly from the world; from all contact with the womanhood of that time, and you will see that there was good occasion for christian women to be advised thus visibly by these outward signs and tokens to separate themselves from the women at that time. But their christianity had to work its way in the world. It had to do a great deal of these things and so the time came afterward when it was safe and proper enough for a christian woman to deck herself with gold and fine wearing apparel. So I found no difficulty in coming before you to-night. I remember in that same Book of divine spiritual directions to which I have referred, there is one earlier than St. Peter spoken of, Bezaleel by name, who was divinely inspired to be a worker in fine gold. I believe that inspiration of Bezaleel was a divine inspiration, upon the principle that every good and perfect gift comes from the Lord, and Bezaleel's gift to work in precious metals was a divine gift. And you who have carried on that work have bettered civilization and have become benefactors of mankind. You have enabled husbands to make nice and pleasant presents to their wives, and you have beautified the homes of all of us and made life easier and brighter. (Applause.)

MR. APPLETON—My friends, the next regular toast that I think our President has designated is:

*"Our National Character."*

When I met Judge Davis here to-night first, I said that he seemed to occupy a sort of parental supervision over the New York Jewelers' Association. And I am sure that whatever position he does occupy, towards you all, it is one of kindly good feeling on his part, and I know that that is responded to on your part by affectionate regard and a very high respect for him individually and for the high official position which he holds. On this toast, "Our National Character," you will be very glad to hear from our old friend, the Honorable Noah Davis.

Judge Davis was received with applause and said:

ADDRESS OF CHIEF JUSTICE NOAH DAVIS.

*Mr. President and Gentlemen:*

I acknowledge that I am old but I am not old enough to occupy much of your time to-night. I have but one minute to speak according to the calendar of the reverend gentleman that has just sat down, and I shall spend but a very few moments in alluding to the text that has been given to me. Texts and toasts are fitly represented by those little signs that you see about the park: "Keep off the grass." No man at these assemblages is expected to speak of the subject given to him. The President told me that my subject should be the American citizen, and I have been contemplating that subject, when I have been suddenly capped and handicapped by another toast: The American Character. After the remarks of Mr. Depew, there is certainly very little opportunity for me to speak of the American character. Of the American citizen I could have said something, because I could have adopted Sam Slick's opinion, which he applied to society. He said society was like a barrel of meat; always bad at the top and bottom, but sweet in the middle. The American character is dependent upon the American citizenship, and American citizenship must depend upon the character of American citizens.

You have noticed that all the speakers so far have been depressed by the condition of things existing just at this moment. We have passed through the most extraordinary canvass that the country has ever witnessed—extraordinary in the manner in which it has been conducted, extraordinary in its personal assaults upon character, extraordinary in the abandonment of discussion of principle, and in the devotion of each party to an attempt to destroy, if possible, the character of its opponents. Now, to a stranger coming from the old world and coming in our midst, what an extraordinary spectacle this has been. If he were a wise man, if a philanthropist, if he were seeking to find here an elevated class of men, seeking to find those who have been made free and were equal to the great duties which were imposed upon them, what sort of an idea would he have of us? What would be his idea of American citizenship and American character. The great trouble with us is that we suffer our passions to carry away our judgments until we overleap our good judgment. We, most of us, know that we have not shown to the world that the American character is truly equal to the duties—the great and important duties and responsibilities that devolve upon it, by the fact that America alone chooses for itself, by the voice of its own people, not only its form of government, but all its citizens themselves who are supposed to be most able to carry on its government for them. Now with these few remarks I proceed to say that no one has any right to derive from the excitement of the hour any estimate whatever of the true American character. I will say this right here of the candidate I supported that I think that he has been most unjustly scandalized. I think that in the conduct of his canvass, during his entire progress through the country, in which he addressed his fellow-citizens in four hundred speeches, he has shown great ability to discuss principle and a desire to avoid personality, with careful discrimination that nothing be said of his opponent. I say that he has shown that capacity beyond that of any candidate whom I have ever known. (Applause). On the other hand, I will say here to-night of the other candidate who has been chosen by the voice of the people (Applause), he I have known longer than I have known Mr. Blaine; he I, as Presiding Judge in Western New York, admitted to the bar many years ago, and he I knew as a practicing lawyer in courts held by myself, and he I have known since I came to this city, but not intimately—that although there had been in his career an unfortunate lapse from virtue, though with that signal and unfortunate incident that has been talked about in a manner not creditable to any one—with that single exception his career has shown him to be a fair average sample of good American citizenship. (Repeated applause). In the high office which he now holds he has

exhibited a capacity which may be reasonably anticipated to make him a good and capable President of the United States. (Continued applause).

The present incumbent of that high office, our own fellow-citizen, General Arthur, who was appointed under circumstances most trying in character, a man of respectable character, by the nature of a firm desire to be just and do right and discharge the duties of any position to which he may be called; he has shown how such a man may grow in such a great place as the Presidency of the United States and fill that office with high honor and win the confidence and the respect of the whole country. (Applause).

If I had any wish in my heart in respect to Grover Cleveland, as sincerely as I believed that it was best that he should not be elected, I say if I have any thought or feeling in my heart against him, I hope it may be crushed out. I am willing to concede to him every possible opportunity for the fullest and fairest trial. I desire him, now that he is elected to the Presidency, to take his seat. May the day never come when the free North shall hesitate to see to it that the voice of the people, as expressed in favor of any nominee, shall be fully regarded by placing him in the office to which he is elected. (Applause, and "Three cheers for Grover Cleveland").

And now that the election is settled, and now that it is determined that Mr. Cleveland has been elected to the Presidency, we have but one duty before us. He ceases under our Constitution to be a President of a faction or of a party, and of any single portion of the people, for he becomes the President of the United States, representing in that high vocation all the people in the United States, independent of party attachments and party ties. (Applause). I desire, therefore, to express the hope that however we may have felt hitherto, however more ardently we may have desired Mr. Blaine to be President, every one of us, looking solely at results which have placed another there, should not hesitate, should not fail to give him that cordial and hearty support in obedience to the law and Constitution for the great and general interest of the country, that we would have given to our own candidate. And that is the true duty and should be the true nature of American citizens; that is, to obey the obligations imposed upon us by the community into which we have entered for the general and common good.

My fellow-citizens, you will pardon me for having made these allusions which may be regarded in some respects as political, but now, as the contest is over, that, according to the laws and forms of our written Constitution, by the voice of the majority of the people, a certain candidate has been selected for the Presidency, now, we have but one duty, and that duty is to uphold the Constitution and the laws, by yielding that measure of obedience and support to the President of the United States that we would want our candidate to have; that we would have demanded from our fellow-citizens if Mr. Blaine had been elected. I know that there is, on the part of many, great despondency, and it may be thought that it will be disastrous to business interests. That depends largely, not upon the President, but upon ourselves. (Applause). If we, who think that the country is likely to be injured by the change, as soon as the change has come, if we remember ourselves to perform our duty and lift up and elevate the country, place our shoulders under business, shaking off despondency and devote ourselves to the affairs of our private interests; if we do that, just as earnestly and as fully as if Mr. Blaine had been elected, you will see all clouds disappear from the horizon. The people of America are equal to meet and forget any disaster. No nation on earth has ever proved that, in such hours of triumph, after disaster as we, when war came upon us, when disaster after disaster befell us, when we of the North were struggling to maintain the Constitution and the government, when we were seeking, not mere triumphs of victory, but the re-establishment of the great and universal government given us by our fathers; what hours of despondency befell us then, at times when all seemed dark and dismal, and yet through all, the American people, the great people of the North, the common folk of the country, stood under the Constitution, bearing it upon their strong shoulders, bearing it from the field of blood to final victory, and restoring the nation to a power greater, more universally free by far than it had ever been before. The same spirit ought to animate us now. Let us not forget that we are alive, fellow Republicans; if we are disappointed in our hopes and wishes, we must remember that we are a part of the country still and be subject to its obligations and duties, and our aim should be to maintain America as pure and as free as ever before when its flag has flown in its greatest hour of trial. (Three cheers were given for Judge Davis and three cheers for Grover Cleveland, the next President of the United States).

MR. APPLETON—The next regular toast is:

*"The City of Brotherly Love."*

In introducing the next gentleman who is to respond to this toast, I will read what I find written on the memorandum of your President: "We have with us a guest, one of her representative men, who will speak for her, and in introducing him I ask to say, that although born in South Carolina and graduated at West Point, when the dark days of twenty odd years ago had fallen on our country, he never swerved from his allegiance, but fought through the whole conflict and now bears the honorable scars received in many battles, and still has vitality enough to answer when called on." I have now the pleasure of introducing to you Colonel Charles H. Gibson.

Colonel Gibson was welcomed with three chairs and responded as follows:

ADDRESS OF COLONEL CHARLES H. GIBSON.

*Mr. President and Gentlemen:*

If there be any truth in arithmetic there is no time left for me, and I am very glad of it. When I accepted the invitation of your society to dine with you, I had no idea that you intended to apply to me the principle of no song no supper, and for a very good dinner compel me, in grateful return, to give a very poor speech. On the contrary, your invitation aroused in me expectation or hopes—I cannot say expectation—what I now see are never to be realized. From my earliest childhood I have always looked upon the jewelers, and especially manufacturing jewelers, with feelings somewhat akin to awe and which I can now scarcely describe. To my youthful imagination they seemed to be the few, the privileged few, destined by benign fate to be the guardians of the whole world—to be the men who were to replace and perform the functions of the mighty magicians of old, to be able to call the pearl from the depth of the sea and the gem from the bowels of the earth; that their eyes first beheld, their hands first grasped, and, more particularly, distributed the priceless treasures of the land and sea. And so deeply was that impression imprinted on my mind, that when I sat down to-night I more than half expected that your President would offer me pearls with my oysters, sapphires with my soup, rubies with the roast and diamonds with the dessert. I had fondly dreamed that he would imitate that gorgeous East whose richest man poured on her kings barbaric pearls and gold, and I was waiting for the showers. If he had given to me that as an illustration, that as a beautiful illustration of brotherly love, my memory would have locked it up in the innermost cells of her heart and thrown away the key. But, alas! the baseless fabric of this vision, as like your once substantial dinner, faded and left not a rag behind, Shakespeare with variations. But that has nothing to do with my theme, and I will endeavor to liquidate the debt. I am called upon to respond to the toast of the City of Brotherly Love. It is a great misfortune that your President did not warn me in time that I should respond to this toast. Had I known before I left my home that such was to be the case, I would have provided myself with accurate copies of the original grant given by King Charles to William Penn, and with an accurate copy of all the records of the Historical Society of Pennsylvania, of which I have the honor to be a member, and with other incidental things regarding Philadelphia. Unfortunately I have not them with me, and my loss is your eternal gain, or words to that effect.

I have often thought that my venerable friend, William Penn, made a mistake, or at least was rather scant in liberality when he named the city of his finding. Mere brotherly love does not go far enough. It wants filling up and running out, so to speak, and had William only lived, I would have called that to his attention. But I think I can readily catch his idea in calling it the City of Brotherly Love—I can, as it were, penetrate the inner veil of his consciousness, as my friend Hamlet would say, and pluck out the heart of his history. The immense resources of William's intellect were concentrated upon traffic with the aborigines under that admirable rule of trade which prevails to the present day, and is known well to the manufacturing jewelers, to get all you can and give as little for it as possible in exchange. (Laughter). For the rich possessions of hill and valley, field and forest, William proposed to give to the Indians a few beads and baubles and other simple trifles, and a great deal of brotherly love—a sort of stock but little known to the benighted heathen, seldom quoted on the market. William passed it on them for its face value and the Indians were content for a while. It was as a memento of the successful dicker on his part, and all the profit lay on his side of the account and the loss on their side of the account, and he named his city Brotherly Love. He had a great deal of love for their lands and they had a great deal of love for him at that day. Now, what I want to draw your attention to is this: the inadequacy of the total brotherly love to Philadelphia. It would have struck any of you that sisterly love was a more valuable asset. Is there any one of you that has

not felt in his heart that fluttering produced by the rapture that he had love for some other brother's sister, and who, under the circumstances, could be satisfied if that other fellow's sister offered him in return only a brotherly love. I say the other fellow's sister could not give to this fellow a brotherly love, and, of course, the first fellow's sister did not want this other fellow's sister to give him even a sisterly love. The impression that I want to convey to your mind is simply this: that William Penn should have developed this idea of mine and incorporated it in the name of his city. The time is coming, and very soon, when women will be recognized and placed in the sphere to which she properly belongs, and Belva Lockwood has opened the way. And why not? What does not man owe to woman? In the beautiful language of the poet:

Who taught our infant lips to pray?  
 Who taught our infant feet to stray?  
 Who pulled us through the milky way?  
 Who spanked our bottom every day?  
 Further the poet does not say. (Laughter).

But it was woman, lovely woman. But this is wandering from my subject. My toast is the City of Brotherly Love. Philadelphia possesses many advantages never dreamed of by William Penn in his dreamiest dream, if I may be allowed the expression. Conveniently situated, midway between the cities of New York and Baltimore, she furnishes admirable shopping facilities for the residents of both of those cities, with stores whose magnificence William Penn never lived to realize. The Delaware river separates her from the opposite shores of new Spain, and furnishes an effectual barrier to the invasion of Jersey mosquitoes. (Laughter). The Schuylkill River furnishes her with an inexhaustible supply of water able and willing to cope with any East river or Hudson river for possessing micro. And I will leave it to any scientist to dwell upon the wealth of its infusoria in quality of richness.

Philadelphia is a city of homes, not the flats and sharps of New York, but houses complete in themselves from cellar to roof, from turret to foundation stone. She has homes for the rich and homes for the poor; aye, and for the criminal she has houses of refuge and correction. It was not of her, however, the sacred poet sang, "Hark, from the tomb a doleful sound," but of another American city well known to you. Our criminals walk in the best criminal circles. Our burglars burgle with elegance and despatch. Our pickpockets pick with politeness. Our policemen club with civility. Philadelphia has more pure politicians, more moral ministers, more quake in her Quakers—well, more in her than any other city within a radius of five miles. Hers is a realm of pure delight. Sorrow sits lightly upon her. There quietude prevails and not unseemly riot. Her matrons and maidens are virtuous. Her sires and scions are brimming over with love, a love that extends to her sisters, and her cousins, and her aunts. (Laughter). I do not know why I should dilate upon this theme. You would not have me tuck the robes or paint the lily. Suffice it for you to know that I reside in Philadelphia, and right here when I see before me some familiar Philadelphia faces, and some of them anxious to put in a word for their city, I want it distinctly understood in the presence of those gentlemen and in the presence of any representatives of the press who may be here, that by my speech to Philadelphia I am putting in a very strong bid for the mayoralty of that city. If I get to be mayor I will rest content. If chance will have me President, chance may elect me and that is all. (Laughter and applause).

MR. APPLETON—And now, gentlemen, the next regular toast, and I am sorry to say, the last, reads:

*"Art as exemplified in the various callings represented in our Association."*

And I have the pleasure and satisfaction of introducing to you to answer to this toast, Mr. J. Seaver Page.

Mr. Page was applauded as he arose, and responded to the toast as follows.

ADDRESS OF J. SEAVER PAGE.

*Mr. President and Gentlemen:*

You will admit that this is a very dangerous predicament that I find myself in. To make a speech to-night after you have heard such brilliant things from all quarters of the globe, and to find one's self here at last to go through and pick up the scraps is an undertaking that falls to my lot. I remember in "Patience," in a part of the opera, the æsthetic apostle sings "hollow! hollow! hollow!" and some one steps in and asks the pretty maiden "Are you hollow?" and she says, "No, I thank you, I have dined." That is my condition, and I find myself too full to get anything off. I could

wish myself in the condition of woman, wherein, this is required of an orator, viz., a quick conception and an easy deliverance, (Laughter) and I wish that I had that acquirement, because I never felt so anxious as I stand before cultivated and polished gentlemen without the slightest evidence of a speech in my head, and try to work one off before you.

I feel like the medical student who was asked by the professor: "Sir," said he, "suppose a man fell down a well ninety feet deep and fractured his collar bone, what treatment would you give?" "Why, bless my soul, I would go and get a few Irishmen and a load of stones and fill the well up." And that is the way that I feel now, ninety feet deep and the want of some Irishmen and a load of stones to cover me up. Or like the Irishman, who, walking along with a friend, saw a bull in a field and said: "Howld on, Jim, a minute, till I tackle the bull." The result was a very short story. He was very soon landed. But he jumped up after a while and said: "Well, begorra, I am glad that I had me laugh first." I feel to-night that I have had the laugh first, and it is a very difficult undertaking to make the last plunge.

You will allow me to-night to just use one little scrap from one of the speakers before me, wherein he alluded to the American character. If you have noticed, there is a very peculiar sandwich in the order of the speakers here to-night. For some reason we are in the order of Democratic and Republican following, and each somehow or other says something clever of the other side, and I cannot help saying something myself. There is one thing which strikes me very peculiarly, which I am glad to see, that whether Democratic or Republican, however trying, however exhausting this canvass, however it aroused the passions, here within five or seven days of election, and what is the result? You have heard one of the greatest, one of the most splendid of our orators speak here to-night. He spoke about our cause beautifully, and what have you seen? A perfect, quiet, beautiful acceptance of the result, and you will find in me one quite willing to second it. However earnest, however hearty, however eager I was that my candidate should be borne to the front, I am to-day just as hearty, and just as zealous in wishing all success and honor to the future President of the United States. (Cheers for Mr. Cleveland and Mr. Page). It is one of those phases of the American character which I feel is fitting and proper to call into service just now. I remember talking with an Englishman recently who was discussing the way we conduct our canvass over here. He said: "I am very much surprised how your people seem so ready to say ugly and unclever things about your candidates, and yet so anxious and eager to say good things about him after the election. In your country I have witnessed the grandest triumph on the part of politics. I have witnessed the most evenly balanced contest, and yet, within seven days of the contest, and all is peace and quietude. The people of a country that can so easily forget their trials and animosities have no doubt a great future, and I congratulate you, my dear fellow, upon this handsome phase of American character."

Now, gentlemen, I said that I had no speech, and indeed I have none. (Cries: "Keep right on." "Give us a recitation"). It is always so easy for one to fall into a recitation line, and as you all seem to be in good humor, where each and every one is accepted with that toleration and gracefulness, it will be my pleasure, after I have finished what I have to say, to give you a recitation. (Applause). I want to just carry a thought further, to say that there is one further lesson that we ought to hold uppermost just now. There is one thing that we cannot learn too often, namely, that after all, America depends upon our stalwart men for her success. There has been a very beautiful truth uttered by Goldsmith long years ago, and which looked, perhaps, into the future of England, but we will make the application ourselves:

"Ill fares the land, to hastening ills a prey,  
 Where wealth accumulates and men decay;  
 Princes may flourish and may fade,  
 A breath may make them, as a breath has made;  
 But a bold peasantry, when once destroyed,  
 Can never be supplied."

Though the clouds may lower, though we may have depression on hand at the moment, we may see our country like some "eternal sunshine settled on its head." And I may truly say that the lesson of the hour is that though the clouds may lower around us at the moment, I have great hope in the future of the country, for the sunshine may be shining on the top.

Now, gentlemen, I have spoken to you longer than I intended. (Cries to go on and for a recitation). If you will allow me just one more thought, for it occurs to me while I am standing here—will you allow me to say one thing slightly unpleasant. There is one thing that I think, perhaps, that I can bring home to you, that each and every one of you—and I address you purely as Americans—will feel a somewhat sense of humiliation to know

that it has not been carried out. I allude to the fact that at our doors is knocking for the moment a great Statue of Liberty, a Statue of Liberty that is offered by France. We are to-day celebrating the great battle of Monmouth, and the State of New Jersey is alive with excitement, and all its people are gathered about Freehold. The battle of Monmouth is upon our lips to-day. At this moment should not some patriotic sentiment cause a thrill to go through the American heart to the memory of the French people in that great struggle through which we passed? Is it necessary to bring up the sufferings of Valley Forge? Is it necessary to call to your attention the fact that in the hour of our greatest need the French people offered us arms? Is it necessary to call to you in this moment in words of patriotic appeal to stimulate you? Do we offer to them a statue? No, but the people that fought with us, that gave their lives for us and for the cause of liberty, have signaled that act by presenting you with a statue to decorate your New York harbor. And how do you Americans receive it? Coldly, blandly, indifferent. It is not anyone's duty, it is everyone's to be stirred up. It is not Democratic or Republican, but every one to be thrilled with an eager enthusiasm to do what he can to save the national disgrace—to save a blot upon the American character. The French people who have contributed to give it have not millions. It was not received from the rich men of France, but from the peasants and people of the provinces, this magnificent statue is knocking at your doors, begging you to receive it and present only the pedestal upon which to receive it. It is no tribute to American character to be thus indifferent. What has been done here to the memory of Lafayette? We have a statue placed here in our Union Square and on the right and on the left the two great apostles of liberty; on the left the statue of Washington—for him you cannot find marble and gold enough on which to write his name—and on the right the great defender of the cause of liberty, who gave his life for the Government, uttering those beautiful words, "with malice toward none, with charity to all." And in the center you have placed Lafayette, the great triumvirate of liberty, honoring him, as you do, as an American and a Frenchman. And yet when the cause of liberty presents you with a memorial statue and begs you to receive it, how do you do it? Ah! gentlemen, I am sorry to spoil this beautiful phase of American character, but I am reminded that it is high time that something should be done, and we must improve every opportunity to call Americans to account for their lack of patriotism in this respect. Let us see that we will have it no longer. Let us see that the memory of Lafayette and Rochambeau is still fresh, and we will do our part to save it from disgrace. A great Frenchman once said about certain wine: "You will find in this wine-growing district that there is a scum upon the surface of the wine, and there are dregs at the bottom, but in the great interior you will find the pure wine." And so I hope that in America, among the great middle men, among the heart of the people, you find the strength and the growth of the American Republic. And so I appeal to you to say let this utterance be prophetic that among the great middle men you do find the strength of the American Republic, and when you appeal to them that you will find them responsive to every patriotic duty. (Continued applause).

In response to the repeated calls of the audience Mr. Page then delivered an amusing dialect recitation about the "Fifteenth Annual Session of the Society for the Distribution of Blankets and Top-Boots to the Cannibal Islands."

Mr. George C. White, Jr., to whose place it properly fell to occupy the presiding chair in the absence of the President, but who, with characteristic modesty induced ex-President Appleton to take the President's place during the evening, arose, and having humorously alluded to the difficulties and trials involved in presiding over the Vice-President's table, proceeded to say:

ADDRESS OF VICE-PRESIDENT WHITE.

We have another toast which has been overlooked. We have to thank our able ex-President for having kindly taken the place to-night which Mr. Alling was so unfortunately obliged to vacate. You have heard from the clergy, you have heard from the bench, you have heard from the bar, you have heard from a twenty-four karat mayor, and you have heard from other gentlemen, but we have not heard anything from a President, although we have heard a great deal about Presidents. This is our tin wedding—our tenth anniversary. Our venerable ex-President, Mr. Baldwin, wrote us a very pretty note of regret, and I will ask you, gentlemen, to fill your glasses to our ex-Presidents, and I will ask our respected ex-President, Mr. Appleton, to dismiss us with his blessing, after which, to invite you all or as many of you as see fit, to sing "Auld Lang Syne," and to come here again one year from to-day. Always elected unanimously and no doubt about the returns. (Applause).

Ex-President Appleton responded:

ADDRESS OF EX-PRESIDENT DANIEL F. APPLETON.

*Gentlemen and Fellow Members of the New York Jewelers' Association:*

As I arise to resume the duties of presiding officer here, I am embarrassed and almost overwhelmed by the consciousness that I am under the eye of the gentleman who last took his seat, and remembering the model presiding officer which he has presented to us with so much ability, and so much grace, and so much to our entertainment. I am not the only ex-President here to-night, and I do not know why I should be called upon to answer to your toast. Your Vice-President, who should have filled this place to-night, has said that there was one of the toasts—the last toast—which I had overlooked. Your President overlooked the toast and overlooked me, for I had no notice of it. As an ex-President of this Association I have very little to say. I greet you, my old constituents, I thank you very much for responding to the call of your Vice-President, Mr. White. Long ago laid up on the shelf, I have but the pleasantest recollections of my associations with you as a member of this Association, as one connected with your business in active life, and as one having had many business relations with you, all perfectly satisfactory to you in every respect. I feel that I was honored as your President. But I was about to talk to you as Mr. Page described in his recitation of the Chairman of the Society for the Distribution of Blankets and Top-Boots to the Cannibal Islands. I thank you very much for the honor that you have given me, and I know that you all join with me in regretting the unfortunate occurrence that prevented your President being with us in the latter part of the evening. He is a gentleman whom you all know well. You chose him as your President, well knowing that in all respects in exercising supervision over all your affairs, he will acquit himself as well as, if not better, than his predecessors. I am quite sure that this illness of his is only temporary, and let us all hope that we shall see him better to-morrow, about his accustomed work. If anything else that I can say would express the regret which has placed me here, I would say that the Vice-President, Mr. White, was abundantly competent to fill this place, and should have filled it himself, but he declined to do so. May I not call upon Mr. David C. Dodd to make some remarks. (Applause).

Mr. Dodd's name was received with cheers and cries of "Dodd," "Dodd," and he responded as follows:

ADDRESS OF MR. DAVID C. DODD.

*Mr. President and Gentlemen:*

Now you are a pretty fine body of men, and I ask if it is fair and if it is honest, after listening for two hours or more to some of the most brilliant orators, to call upon me at this late hour to say a word as we are about to separate. (Laughter, and cries: "Perfectly honest," "Perfectly honest"). I think that it was one of the sweetest and best of Scotland's poets who said that man was made to mourn, and I thought, as we gathered here to-night, that I saw a tear in the eye of many of the members of our Association, meeting for the first time after the severe contest through which we have passed during the last few months, and yet I think that there is a hearty response on the part of every individual gathered here to-night—a hearty response, though it may be a little hard on the part of a great many of the American people, now that the battle has been fought and the question decided, to cheerfully, quietly and honorably submit to the decision of the American people.

I think that there is a sense of regret in the minds of the members present to-night in the fact that our esteemed President should be so afflicted by illness as to have been prevented to preside here on this occasion. To occupy the President's chair is a sort of test, I may say, to those who are not accustomed to meet with us around this social board—it is a sort of test as to the metal of the man, and we knew when we chose Mr. Alling as our President that he was fully competent to assume the responsibilities and meet the requirements of the Association. I know when I express this regret that I express simply the regret of every gentleman at these tables. (Applause). In a sense, we have lost our President through sickness, in another sense, some of us have lost our President for want of votes. (Laughter). In both cases, I suppose we submit to the overruling hand of Providence. But the nation and the Jewelers' Association will live, and I know that, as far as the President of this Association is concerned, the sentiment of his fellow members is that he shall preside here next year—we shall insist upon it on another occasion that he shall preside, and sick or well, we intend that he shall occupy the chair at our next annual dinner. (Applause). We are not usually in favor of third terms, and we elect some of our Presidents for two terms, but I think that we must have Mr. Alling for three terms so that we can insist that he shall occupy the chair at, at least, two annual dinners. No individual member can more sincerely be

trusted with the representation and honor of the Association to which we belong than Mr. Alling. We have listened with interest to the remarks of the gentleman who said this evening that he was long acquainted with Mr. Alling, and lived in the same town with him when they were boys in Indiana. Though I have not, perhaps, enjoyed so long an acquaintance with him, yet I have a right to say that among his friends, among those who know him well, there is no man more highly esteemed, and for whom a greater regard is entertained on the part of every business man with whom he comes in contact. (Applause). And in making these remarks, I do not intend by any means to detract in any sense from the ex-President, Mr. Appleton, who has presided, and who has so ably and so well represented him on this occasion. I think, sometimes, that we are a sort of mutual admiration society, but I know no other reason and no other measure of judgment that leads to this high opinion, which is entertained among the members of the Jewelers' Association for other members, than the simple fact that the rules of integrity and of business honor may be applied to them without fear of challenge or a question as to the result. And I know another thing. I know if you are not unanimous as to the remark I have just made, you are unanimous in the truth that you know where to go to get good dinners, and you know how to order them. Mr. President and gentlemen, I should not have trespassed on your time but for the simple purpose of paying a tribute to the President of our Association who has been compelled to absent himself, unfortunately, this evening. (Mr. Alling was here toasted, and three cheers were given him by the members). And finally, gentlemen, let us drink to the memory of one who has been with us on all former occasions of this sort, but whose face is missing to-night, whose familiar countenance we shall see no more. He was a warm friend of this Association and of its interests, and his genial face was known to us all. I propose that we drink in silence to the memory of Mr. Daniel H. Hopkinson, the late editor of THE JEWELERS' CIRCULAR.

After the toast had been drunk the company sang "Auld Lang Syne" in chorus, and was then dismissed.

Among the invited guests who were unable to be present at the annual dinner of the Association, letters of regret were received from the following named persons: Chester A. Arthur, President of the United States; Rev. John R. Paxton, Rev. William M. Taylor, Rev. John Hall, Rev. Robt. Collyer, Rev. Howard Crosby, Rev. Edward B. Coe, Rev. C. H. Parkhurst, Surrogate D. G. Rollins, Abram S. Hewitt, Judge Charles P. Daly, M. G. Baldwin, John R. Cravens, A. S. Keasby, Stewart L. Woodford, Otto Young, President of the Chicago Jewelers' Association; George Jones, Editor of the New York Times; Theodore Roosevelt, James H. Goldey and Rev. Winchester Donald.

### The Jewelers' League.

*President*, GILBERT T. WOGLOM.....Of Woglom & Miller.  
*First Vice-President*, WM. C. KIMBALL.....Of H. F. Barrows & Co.  
*Second Vice-President*, AUG. KURTZEBORN..Of L. Bauman Jewelry Co. St. Louis, Mo.  
*Third Vice-President*, JAMES P. SNOW.....Of G. & S. Owen & Co.  
*Fourth Vice-President*, HENRY HAYES.....Of Wheeler, Parsons & Hayes.  
*Secretary and Treasurer*, WILLIAM L. SEXTON.....Of Sexton & Cole.

#### EXECUTIVE COMMITTEE.

ROBERT A. JOHNSON, *Chairman*.....Of Colby & Johnson.  
 SAMUEL W. SAXTON.....Of Saxton, Smith & Co.  
 CLEMENT B. BISHOP.....Of Carrow, Bishop & Co.  
 JOSEPH B. BOWDEN.....Of J. B. Bowden & Co.  
 GEORGE R. HOWE.....Of Carter, Sloan & Co.  
 CHARLES G. LEWIS.....Of Randel, Baremore & Billings.

THE JEWELERS' CIRCULAR is the *exclusive* official paper of the Jewelers' League, and has been selected for the publication of all matters of interest pertaining thereto. Letters or inquiries pertinent to its business or purposes, and which might interest the trade or inquirers, will herein be answered. Address *Jewelers' League*, Box 3,444, P. O., New York, or the office of THE CIRCULAR.

At the regular monthly meeting of the Executive Committee of the Jewelers' League, held Nov. 7th, 1884, there were present Vice-Presidents Kimball and Snow, and Messrs. Johnson, Howe, Saxton, Bowden, Sexton and Dr. Wilbur.

Treasurer reported a balance in the General Fund of \$2,715.64.

One application was rejected.

Three were referred for investigation.

Six changes of beneficiary were granted.

The following 14 applicants were accepted:

P. Dunn, O. W. Maddaus, F. N. Reeve, C. H. Welch, N. Y. City, N. Y.; W. R. Barnes, Rochester, N. Y.; H. M. White, No. Attleboro, Mass.; J. J. Ehmann, T. H. Krementz, Newark, N. J.; C. F. Lauterbach, Petersburg, Va.; J. T. Gourley, Springfield, Ill.; S. B. Emmons, Mendon, Mich.; A. Travis, Jackson, Mich.; A. Eisenberg, M. Spiro, San Francisco, Cal.

There were also several notices of proposed changes in the Constitution to be acted upon at the Annual Meeting in January. These will be mentioned at length in our next month's paper.

### Our Providence Letter.

[FROM OUR SPECIAL CORRESPONDENT.]

**B**USINESS continues in a very depressed condition. There are not six factories in the city, to-day, working on full time, and there are none who employ their full complement of hands. This state of things bears heavily, not only on the manufacturers, but by reflex action, if I may use the expression, upon the whole of the business community. The manufacture of jewelry is the leading interest here, as the following statistics, which I have compiled from reliable data, will show :

There are 183 firms or individuals engaged in the business. They employ a capital of \$3,500,000, and give employment, when running on full time, to 7,000 persons, of whom one-fifth are females. The wages of the males range from \$4 to \$30, and the females from \$4 to \$10 per week. The aggregate amount of wages paid annually to these persons exceeds \$2,000,000. The production, when all the factories are in full operation, amounts to over \$6,000,000. Forty-seven firms manufacture gold goods, and the balance rolled gold and electro plate.

The glaring and unexpected failure of Dahlheimer alluded to in my last letter, has since been supplemented by those of Kopelowich Bros., of Syracuse, and Gowan H. Cragg, of New York City. It is some satisfaction, however, to know that these individuals have no prospect of getting a settlement, and stand a good chance of acquiring a practical insight into the working of some of our State institutions. An inspection of the books of one of these parties showed seven merchandise accounts aggregating about \$5,000 and purporting to have been settled a few weeks before failure, which on investigation showed that no such firms were, or (so far as could be ascertained) ever had been in existence.

The Jewelers' Board of Trade is now organized, and has published a Constitution and By-Laws. The officers consist of a President, two Vice-Presidents, Treasurer and Secretary, and the government is invested in a board of fifteen directors. Mr. Dooty Wilcox has been elected President, and Mr. Jno. McCloy, Treasurer. The Secretary is not as yet appointed. About fifty houses in Attleboro and here have signed the Constitution, but somehow or other things do not appear to work very smoothly; at all events but little progress towards getting into working order seems to have been made. Many of the old houses here have refrained from joining, because, as they say, they want to see clearly the line of action the Board of Directors will take, and also whom they will select as a secretary. The question of the secretaryship at the present time causes considerable feeling among those interested. The trade generally hold that on the ability of the secretary depends the existence, not to say the success, of the Board of Trade, and they are strongly in favor of employing some one thoroughly conversant with the trade and its credit, even if they have to pay a liberal salary for such services, while on the other hand some of the board of directors are understood to be in favor of employing a young, inexperienced man at a small salary. The folly of the latter course is so obvious that it



requires no comment, but I venture to prophesy that upon this issue depends the success or failure of the undertaking.

The firm of Godfrey & Gardiner dissolved by limitation on November 1st, and Mr. Gardiner retired. They are succeeded by Godfrey & Adams.

Hudson & Farnum are taking stock preparatory to a dissolution. Mr. Farnum will retire from the concern.

Mr. Keach, formerly of Keach & Price, has been appointed receiver for Lester & Chadwick, and will settle up their affairs.

The second concert of the season, given by the New England Manufacturing Jewelers' Association, is announced for the 29th inst. We notice that Mr. H. Holland, of Holland & Gosling, is billed to take part. Our friend Harry will find his efforts thoroughly appreciated by his Eastern friends.

ASMODEUS.

Providence, R. I., Nov. 15, 1884.

## A Review of the Experiments of the Old Masters of Horology.

*Continued from page 324.*

A TIMEPIECE with spring is frequently charged with such functions that the greatest uniformity of its motive power, and consequently its regularity of rate, becomes an indispensable condition, and in such a case it is absolutely necessary to employ a fusee. Nearly all chronometers are provided with such a contrivance, which, containing the principal wheel, transmits the power of the spring to the train. This fusee is in the shape of a truncated cone, and the spring imparts to its activity by means of a chain which winds and unwinds in a spiral-form groove cut upon the surface of the fusee. When the spring is wound it actuates upon the part of the fusee nearest to its axis, therefore, upon a short lever, gradually, however, as the spring, when uncoiling, loses its power or tension, it exerts its effects upon those parts of the fusee proportionally further removed from the axis, therefore, upon a longer lever. In this manner, it will be seen, that by duly making the shape of the fusee proportionate to the length of the operating lever and the decreasing power of the spring, it becomes possible to perfectly equalize the increasing loss of strength of the spring.

Experience has demonstrated, however, that it is not indispensably necessary to employ a fusee to make the rate of a good watch, for instance, a chronometer, uniform, and that the watchmaker can obtain very satisfactory results by employing the going barrel, which operates immediately upon the main pinion of the train. On account of its simplicity it offers great advantages, and the several defects almost impossible to be eradicated from the compound mechanism of the fusee and maintaining power, as well as the danger that the chain break, are thereby avoided.

It is possible to obtain an almost perfect uniformity with the help of going barrels, if the proportions of the watch are such that the barrel can be made as large as possible; because in this case it is possible to employ a very long spring with many coils around the core; if then only a few coils are used for the motion of the watch, it is obvious that the difference in the motive power, whether the watch is wound or whether it is run down, can never be very great, and, in proportion to the length of the mainspring, it is only very small. These long and flexible springs possess another advantage: They retain their elasticity better, and are less subject to breaking than strong and short springs, such as are generally used in watches with fusee. The latter property of a spring is very valuable, especially in chronometer, in which the breaking of the spring would be a serious detriment while on a voyage.

By the means indicated in the preceding it becomes possible to reduce the inequality in the motive power to a minimum quantity, although it will never be possible to eliminate it entirely. It is plain

that the spring must operate with more power when recently wound than when half way down, and that it diminishes in strength in ratio with the quantity it uncoils during the goings of the watch. This minute quantity of inequality in the motive power, however, has no influence upon the rate of a chronometer, if care is taken to render the balance spring isochronous, because the more or less large arcs of the balance vibrations will be performed in the same time and the rate of the watch will not be altered.

As far as the spring itself is concerned, it is essential that it be made of tough steel, not easily inclined to breaking and possessing the property of assuming a high degree of hardness, which is to be as uniform as possible. But this exertion of care lies with the manufacturer, and springs should be purchased only of parties who are willing to take the necessary care. Broad and feeble springs are preferable to narrow and strong, because the former are less subject to the danger of warping and wedging themselves in the barrel than narrow springs, and, consequently, they are less apt to rub against the bottom and cover of the barrel. It is also advisable to have the edges of the spring well rounded off and polished so as to lessen the friction in the barrel.

The spring must not rub during its unfolding in the barrel because this friction, which is not always equal, would continually alter the power of the spring; this is another point by which the manufacturer of springs can exhibit his skill.

We have seen some time ago that the isochronism of the balance spring can neutralize the effects of inequality of the propelling power of a watch. With astronomical clocks, this propelling power is always the same, but this invaluable property of the motive power does nevertheless not produce entirely the effects desired.

The frictions in a clock will augment after a time, be it either on account of the thickening of the oil or for other causes, and the restoring power periodically imparted to the pendulum will constantly diminish, and the oscillations of the pendulum become smaller in ratio with the increase of its frictions. The more or less large oscillations of a pendulum are not isochronous, and the small amplitudes will be accomplished in a shorter time than the large; consequently the pendulum oscillations will become faster in the same ratio as the restorative power imparted to the pendulum decreases, and the clock will gain.

This non-isochronism of the pendulum oscillations, therefore, is the reason that the unvarying uniformity of the motive power, obtained by the employment of weights, after all does not produce as much regularity as might be expected.

It would also be desirable that the quantity of the motive power of an astronomical clock could be increased in proportion with the resistance occasioned by the augmenting friction and thickening of the oil. In order to effect this, Jurgensen attached an empty cylinder to the running weight of his astronomical clocks, of the same size and form of the weight, into which he placed a grain of lead of suitable weight to increase the propelling power, for the purpose of sustaining the oscillations of the pendulum at the same amplitude.

It is requisite to provide an astronomical clock with a maintaining power for preserving its rate while it is being wound. This remark also applies to chronometers with fusee. We shall describe this mechanism farther on, and it would, therefore, be superfluous to enter into details at present. We will only state that the maintaining power causes a large increase of work, and that it is necessary to be very careful in making it if we wish to be correct in its functions.

When the going barrel is employed in chronometers in place of the fusee, the mechanism of the maintaining power is dispensed with, since a going barrel has the property of keeping the watch going while it is being wound. The endless cord formerly used might be employed in astronomical clocks, and the maintaining power for them would also be dispensed with in this manner.

It lies in the nature of the endless cord to keep the clock going while it is being wound. But it possesses many imperfections, and, in order to make the astronomical pendulum perfect, it is necessary

that the weight operate in the manner as indicated in the following, and that a maintaining power keep the clock in motion while it is being wound.

The following remarks on the above subject we condense from the work on horology, written in the French language, by the celebrated Mr. Jurgensen and issued in Copenhagen:



FIG. 22.

Fig. 22 shows a mainspring, as seen from above, and fig. 23 gives a side view. Fig. 24 represents the going barrel as contained in a watch without fusee. The outer end of the spring operates on a hook *a*, to which it is fastened by means of a square hole. Fig. 25 shows the barrel arbor, the ends of which move freely but without shake in the openings *c d* of the barrel. Fig. 26 shows the profile of the barrel, as well as the arbor,

which is fastened in the two plates; *b* is a ratchet or a steel wheel with inclined teeth, and *a* is a click bracing against the wheel teeth and thereby preventing its return motion. The click is by a spring

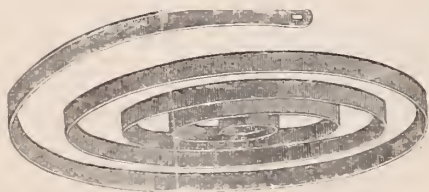

FIG. 23.

continuously pressed against the wheel; click, ratchet and spring are by themselves shown in figs. 27 and 28, and the several pieces together constitute the click work. The barrel is around its circumference provided with teeth, which

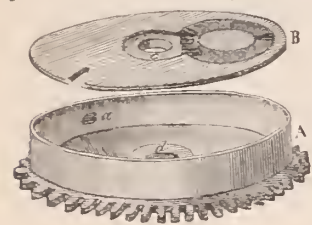

FIG. 24.

depth into the first pinion of the train. If we imagine the teeth of the barrel as retained by the just mentioned pinion, it will be seen that the spring can be wound, by revolving the arbor to the appropriate side, and that the spring will thereby coil around said arbor. The spring coiled in this manner will, by reason of its elasticity, seek to regain its

free condition, and it operates with its whole power on the barrel arbor as well as on the barrel itself. The arbor, which is prevented by the click work, remains motionless, and the whole power of the spring operates on the pinion depth into the barrel teeth, and communicates the power of the spring to the other wheel, as we shall see farther on.



FIG. 25.

Nor must the first coils of the spring act upon the train, because they exert a greater power than the last coils and the operation of the spring would thereby be made too irregular.

When we make the spring blade and the diameter of the barrel and barrel arbor of such a size that the spring, when wound, can be given seven coils, it suffices to protect it against breaking or yielding,



FIG. 26.

and to secure to it a satisfactory equality of power in its different

coils, by winding only five coils, so that two remain at rest; and again, of these five coils only two and one-half, or three at most, must act on the train. This is effected by a simple mechanism, to wit:



The stop work, which is contrived in such a manner that the male stop makes  $4\frac{3}{4}$  revolutions before the arbor comes to be stationary, because, by the first revolution of the male stop to the right, part 1 of the wheel advances by one tooth; by the second turn, part 2 advances; by the third, part 3; by the fourth, part 4; and before the fifth revolution is completed, the male stop remains on the outer circumference. If the female stop had one notch less, then the arbor could make only  $3\frac{3}{4}$  revolutions, and, if it had two notches less, then only  $2\frac{3}{4}$  revolutions. The number of these notches may therefore be increased or diminished at will, according to the number of revolutions which the barrel is intended to make. To prevent the feeblest two coils of the spring from operating on the train, the spring is wound two coils, after which the male stop is placed into action.

The danger that the spring lose its elasticity is lessened with the length and number of coils it makes in the barrel; because in such a condition more coils can be left at rest, and at the same time the spring can be wound sufficiently. The watchmaker must, therefore, try to make the barrel as large as possible. If we assume the barrel to be so large that the spring can make nine coils, and that at the same time two revolutions of the barrel suffice to sustain the going of the watch for the required length of time, it will be seen that the spring could be wound four turns, and that, together with the two revolutions necessary for the going of the watch, there would still be left three coils to serve as rest. In consequence of this arrangement the spring would actuate with an ever-equal power.

Going barrels are very suitable in watches for every day use, and although their springs do not act with the highest attainable regularity, still experience has demonstrated that these minute inequalities of power produce no irregularity of rate in watches with dead-beat escapement. Beside they possess the advantage that watches with such barrels when being wound keep on going, because, although the spring is wound at its inner end, it continues to act with its outer end on the barrel rim, and, therefore, it does not cease to exert its influence on the train.

It is indispensable that the spring be made of good steel, and that it be hardened as uniform as possible. It is also necessary that its blade be highly polished, in order to lessen the friction to which it is exposed when coiling or uncoiling. The spring must be uniformly broad and its edges be well rounded off, so that it neither injures the bottom nor the cover of the barrel, and that the friction becomes as gentle as possible. It is also advisable to use very broad springs, as this kind is less inclined to warp in the barrel than narrower ones, and, therefore, rub less on the bottom and cover of the barrel. The two ends of the spring must be annealed so that the holes can be more easily punched in them by which the spring is fastened, and to keep it from breaking at these places. In order to facilitate the fastening of the outer end in the barrel, and to avoid its bending at this place it is well to use a spring winder. When the spring is located in place, it must be slightly lubricated for the purpose of lessening the frictions of the coils.

A watch may be arranged in such a manner that in consequence of the peculiarity of the escapement, the greatest uniformity of the motive power becomes an essential factor in producing a regular rate. In chronometers, also, in whom even the most trifling sources of irregularity are to be avoided, uniformity of the motive power must be produced in the most careful manner. But to obtain that the operation upon the train become uniform, it is necessary to employ the fusee, bearing the first wheel for transporting the power of the spring upon the other portion of the train. This fusee has the form of a truncated cone, and the spring imparts to its effectiveness by means of a chain, which winds and unwinds in a spiral groove around the circumference of the fusee. When the spring is

wound, it actuates upon a part less distant from the axis of the fusee or upon a short lever; in the ratio, however, as the spring uncoils and loses its tension or power, it actuates upon a part farther removed from the axis of the fusee or upon a longer lever, so that if the fusee is constructed in correct proportions, a perfectly uniform action of the spring can be produced, even when it has almost lost its power.

Fig. 29 gives the upper view of the barrel which operates upon a fusee by means of a chain. *A* is the drum, *B* the fusee, *C* the chain

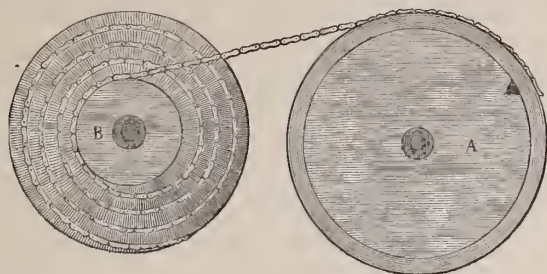

FIG. 29.

wrapped in the spiral groove around the fusee. Fig. 30 gives in profile the drum with the chain and fusee between the plates; *b b* is the barrel ratchet which is fastened upon its arbor, and *a* the click resisting the ratchet. This click work prevents the return motion of the arbor, and serves at the same time to coil the spring. The axis of the fusee ends in a square, as will be seen at *c*, and by means of

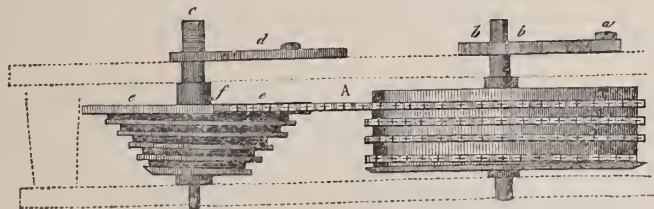

FIG. 30.

this square the fusee can be turned or the spring wound. The chain actuates upon the barrel through the hook seen in fig. 30, which is fastened in an opening at the circumference of the barrel; upon the fusee, however, by a hook which catches around a pin fastened in a notch in the first groove of the fusee. When the fusee is turned so that the chain unwinds from the barrel and winds upon the fusee the barrel revolves and the spring is wound, since the barrel arbor remains stationary (fig. 29). The fusee must be stopped, however, as soon as the whole length of the chain is wound upon it else it would break. This stoppage is effected by another very simple apparatus.

The fusee carries a wheel which seizes into the first pinion of the train, and thus communicates the power of the spring to the escapement as was said previously. This wheel will make as many revolutions as the chain has wraps around the fusee, and its motion will always be in the same direction. When the fusee is run down, that is, when the chain is run down, it must be wound again without disturbing the wheel. For this purpose a click work is located in the interior of the fusee which is arranged in such a manner that the spring may be wound without disturbing the wheel, and that after the winding of

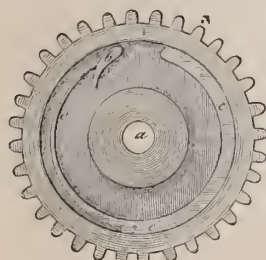

FIG. 31.

the spring the wheel follows the direction of the fusee. The click of this click work is fastened in a recess made into the fusee, and the click, together with the spring that presses it against the ratchet, are fastened to the wheel. Fig. 32 represents the fusee with the ratchet; *b* is the axis around which the wheel, fig. 31, moves freely but without shake; the spring *c c c* presses against the click *b*, which braces itself against the teeth of the ratchet. The wheel is very easily pressed against the fusee by a ferrule, which is mounted with

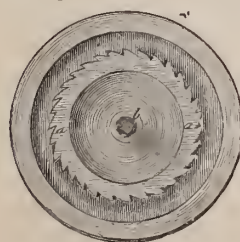

FIG. 32.

friction upon the arbor or axis of the fusee down into the recess made in the wheel.

The shape of the fusee depends upon the spring and cannot be determined beforehand; it is rather difficult to effect that the power of the spring operate with the greatest possible regularity upon the train, and it can only be produced by experiments. While the spring is being wound it cannot operate upon the train, and in order to overcome this defect, a mechanism is used, which, by means of a maintaining power, acts during the ineffectiveness of the spring. We shall describe this mechanism at a future time.

(To be Continued.)

## Workshop Notes.

—Pencil drawings may be preserved by pouring over them, when stretched upon the drawing board, a thin solution of gum arabic or the white of an egg dissolved in dilute ammonia water by agitation with broken glass.

COLORING JEWELRY BY GALVANISM.—Fr. Weil has exhibited to the French Academy various articles of jewelry, which were colored by metallic layers deposited by electro-chemical processes. The colors have a great artistic value, and are very durable, resisting friction, moisture, sulphuretted hydrogen, vapors of ordinary illuminating gas and the action of light. Edmond Becquerel recalled the experiments of his father, in coloring metals by means of thin layers of oxide of lead and oxide of iron. He obtained very brilliant shades of various colors, and he found by increasing the thickness of the layers he could effectually protect metals from rust.

WOODEN MIRROR.—A French journal describes the Rubemick process of metalizing wood, as follows: The wood is first immersed for three or four days, according to its permeability, in a caustic alkaline lye (calcareous soda), at a temperature of from 75 to 90 degrees. From thence it passes directly into a bath of hydrosulphite of calcium, to which is added, after 24 or 36 hours, a concentrated solution of sulphur in caustic potash. The duration of this bath is about 48 hours and its temperature is from 35 to 50 degrees. Finally the wood is immersed for 30 or 50 hours in a hot solution, 35 to 50 degrees, of acetate of lead. This process, as may be seen, is a long one, but the results are surprising. The wood, thus prepared, after having undergone a proper drying at a moderate temperature, acquires under a burnisher of hard wood a polished surface, and assumes a very brilliant metallic luster. This luster is still further increased if the surface of the wood be first rubbed with a piece of lead, tin or zinc, and be afterward polished with a glass or porcelain burnisher. The wood thus assumes the appearance of a true metallic mirror, and is very solid and resistant.

CUTTING GLASS.—The following directions for the old process of cutting glass with a red hot iron are sometimes sold to the unwary as a great secret. The method is very simple, and to those who have failed with the recipes usually published (strings with turpentine and set on fire, friction with strings), the results are rather surprising. There is no difficulty in cutting off broken flasks so as to make dishes, or to carry a cut spirally round a long bottle, so as to cut it into the form of a corkscrew; and when so cut glass exhibits considerable elasticity, and the spiral may be elongated like a ringlet. The process, as has been said, is very simple. The iron rod (a common poker answers very well) should be made somewhat pointed, and the line along which the cut is to be made should be marked by chalk, or by pasting a thin strip of paper alongside of it; then make a file crack to commence the cut; apply the hot iron and a crack will start, and this crack will follow the iron wherever the operator chooses to lead it. In this way jars are easily made from old bottles, and broken vessels of different kinds may be cut up into new forms. Flat glass may also be cut into the most intricate and elegant forms.

## Trade Gossip.

C. G. Alford, of C. G. Alford & Co., has just returned from California.

J. Eugene Robert and family returned Nov. 11, in the steamer *Normandie*, from a seven months' sojourn abroad.

Bradford & Troughton, manufacturing jewelers, of Providence, having resolved to discontinue business, have gone into voluntary liquidation.

A. K. Sloan, of the firm of Carter, Sloan & Co., accompanied by his wife, has gone to the Pacific coast on a business trip. He will spend the month of December in San Francisco.

Albert Lorsch, dealer in precious and imitation stones, has opened an office at No. 179 Broad street, Providence, and is prepared to supply the trade with everything desired in his line.

On Wednesday, Nov. 19, B. S. Freeman, Jr., was married at North Attleboro to Miss Myra A. Ballou. The newly wedded couple received the hearty congratulation of hosts of friends.

Desire Bournique, one of the oldest watch case manufacturers in this country, died Nov. 19, at his residence, Milford, Pa. He was fifty-one years of age, and highly esteemed in the trade.

The American Watch Company will exhibit a full line of their goods at the New Orleans Exposition. These will be displayed in a most attractive manner, and will, no doubt, form one of the most popular features of the exhibition.

The itinerant vendors of presidential medals, badges and charms have, happily for the community, turned their attention to other things, and now devote their attention to jumping jacks, woolly dogs and other instruments of baby torture included in the list of holiday toys.

The Philadelphia *Press* says that the new variety of smelling bottle which the ladies are carrying this year is one of great utility. When not in use for smelling it can be pressed into service as a pickle jar or a celery glass. Some of the better developed ones are used with due effect as umbrella rests.

The Travelers' Protective Association met at Louisville, November 15. Legislation looking to the protection of drummers' interests was discussed, and several hotels in various cities were ordered to be boycotted. The next convention of the association will be held at Philadelphia during the last three days of June, 1885.

One of the latest French clocks is made of brass in perfect imitation of a lighthouse, having a revolving top. On the revolving part are two dials, one marking the time and the other being a barometer; between these are two thermometers. As the lighthouse revolves, first one and then the other dial is brought into view. It is an elegant design and as useful as ornamental.

Following in the footsteps of the New York jewelers, who have formed a mutual security alliance for the purpose of bringing to justice the burglars who may rob their premises, the jewelers of Toronto, Montreal, Hamilton and other places in Canada have formed a similar association. Pinkerton's detectives will be employed should the store of any member of the association be burglarized.

Henry C. Haskell, of No. 12 John street, has introduced many attractive novelties for the holiday trade. Among these are rings of every description for gentlemen and ladies, including special lines of garnet, pearl, intaglio, cameo, tiger stones, etc. Also many novelties in sterling silver jewelry, which is now becoming very popular. These latter include bangle bracelets of every description, pins for monograms, sleeve buttons in antique and nugget finish, monogram coins, and various other attractive and desirable goods.

Joseph P. Wathier & Co., of Chicago, have found a large and unexpected demand for Wathier's Hair Spring Stud Index, which is conclusive proof that its merits are highly appreciated by the trade. This firm has increased its facilities for watch and jewelry repairing, and are prepared to do work of this kind for those in the trade who have more on hand than they can accomplish during the busy holiday season.

By imperial decree dated June 7, 1884, a trade mark law has been promulgated in Japan, the law going into force on the first of October. Persons who counterfeit registered trade marks and employ them, will be punished by imprisonment with hard labor for a term of not less than thirty days and not more than one year, in addition to a fine. A trade mark in Japan runs for 15 years. Nearly all classes of goods manufactured are included under this new act.

A new clock has been invented and is coming into use in Europe, which is warranted by its manufacturers to run for five years without either winding or regulation. The Belgian Government placed one in a railway station in 1881, sealed with the Government seal, and it has kept perfect time ever since. If these watchmakers keep on some of them will discover perpetual motion yet, and invent a clock that will run through all eternity without winding. Then what will become of Keely?

We have previously alluded to the fact that "Gus" Walter had severed his connection with the firm of Albert Berger & Co. for the purpose of engaging in other business. He has formed a company known as the T. A. Willson Optical Company, of which he is president. The company has taken offices at No. 14 Maiden Lane, and will be ready for business January first. Mr. Walter has an extensive acquaintance with the trade, and will undoubtedly make a success of the company, which will handle the optical goods bearing the name of T. A. Willson.

S. F. Myers & Co. have recently issued a very extensive illustrated catalogue which they call "The New York Jeweler and Trade Price List." It contains illustrations of almost everything known to the jewelry trade, and gives the list prices of the various manufacturers. A special discount sheet is sent out by them under separate cover to persons who are recognized as legitimate dealers, due care being taken that this does not fall into improper hands. The catalogue is an exceedingly comprehensive one, embracing pretty much everything in the line of jewelry, is handsomely printed, and may be had on application.

The Meriden Britannia Company has arranged to exhibit a full line of their elegant goods at the New Orleans exhibition. Frank E. Knight will be in charge of the exhibit, and ready to impart to visitors the fullest particulars regarding this industry and the great progress it has made in this country of late years. The Meriden is an enterprising company, and the large and complete exhibition of goods it will make on this occasion cannot fail to be a benefit to the entire trade. Perhaps the day will come when we shall have a permanent exhibition in this city of the exquisite workmanship of our gold and silversmiths, manufacturing jewelers and horologists.

A novelty in clocks that is attracting much attention is manufactured by the Wm. L. Gilbert Clock Company. It represents the old independence bell that adorns Independence Hall in Philadelphia. The bell has a rolling motion similar to the bell on a locomotive. It is fastened on the top of the clock by two hollow pillars, one on either side, through each of which pass a cord wound twice around the bell beam in opposite directions, so that when one unwinds the other winds up. One cord passes through each pillar and is fastened to the end of a small brass rod having a central axis and propelled by power transmitted by the alarm gear through a system of levers having a positive motion. This construction is very simple and easily repaired. The tone of the alarm is loud and clear and will run much longer than the old style.

F. I. Hurstenstein, a Connecticut farmer, recently lost a valuable ring in a singular manner. While talking politics in the street he emphasized an argument by swinging his arm vigorously in a downward direction, when off flew the ring. All search for it at the time proved unavailing, but it was finally found by a man named Webster in his wagon, which was standing opposite Randall's when the ring disappeared. The ring must have bounded from the bricks into Mr. Webster's open wagon and took a ride home with Mr. Webster.

The *Jeweler and Metalworker* of London calls attention to a beautiful jewel recently on exhibition in that city. It is a valuable sapphire with peal pendant, designed and made for a leading British official in the colony of Fiji. This beautiful work of art consists of a star of eight rays, the two larger of which terminate in single pearls of fine shape and unusual size and brilliancy; the others in a *Fleur-de-lis*, in the center of which is a pearl. In the centre of the star is a large fine brilliant sapphire, surrounded by upwards of forty beautifully shaped pearls.

Local shopping for the holidays has already begun, and the retail dealers are having quite a run of custom, which will increase in volume as Christmas gets nearer. Some special orders for elaborate presents have also been placed with manufacturers, and will result in their producing some elegant pieces of original and novel designs. It is getting to be quite "the thing" for wealthy persons who desire to make costly presents to their friends, to order something unique, made from a special design, which will not be duplicated. We commend this idea to our millionaire friends—it is a good thing to do and benefits trade.

An improvement in keyless watches, invented by a Mr. Hurle, of England, is thus described in *Invention*: "The winding stem is superseded by a simple winding wheel, projecting slightly from the rim of the watch, in order to be actuated by the pressure of the thumb. It is well known that in ordinary stem winding watches the movement is more or less cramped by the extent of room occupied by the winding arrangements, whereas in this new arrangement there is the same internal space for the movement as in the case of watches wound with the ordinary key. Our only fear is that dust might accumulate at the slight opening on the edge of the rim whence the winding wheel slightly projects."

Mr. Samuel Joel, of No. 223 Grand street, has recently patented and now offers to the trade a new tool for the use of diamond setters, manufacturing jewelers and polishers. It is designed to hold the setting securely while setting or polishing the stone that belongs to it. The tool consists of a cylindrical piece of metal which is perforated by slots; by turning a screw the points of the metal bar open or close; this is inserted inside the setting, and expanded till it clasps it tightly, thus enabling the workman to handle it in any way. It does away with the old process requiring the use of cement, wax or shellac, and is as convenient as it is useful. An illustration of this tool will be found on another page of this issue.

A firm of London jewelers thus explain how they were swindled: A man came into their establishment and selected an expensive gold watch, the best chain they had and the finest bracelet, the three articles amounting to £136. They were to be sent home to a large house in one of the best West-End squares at an appointed hour. Punctual to the time two of their assistants went with the goods, and were admitted by a servant and saw the victimizer, who took the articles out of the room "to show the lady." Their assistants felt at ease on account of the valuable articles in the room, it being the private house of a wealthy gentleman. They waited, as they thought, long enough, then rang the bell; a servant answered, and on enquiring where Mr. — was they were told he had been out some time. "Who was he?" they said. The servant replied, "He is our footman." The plan unrolled itself—the man had chosen the hour, told his fellow-servants that some friends of his own were coming, and had donned private clothes for the occasion instead of his usual livery.

Simon Dessau, the New York diamond importer, on the day after election commenced cutting a very large diamond, weighing 78 karats, which will weigh 40 to 50 karats when finished. It is without a flaw and will be worth \$40,000 to \$50,000 when cut. Mr. Dessau has named it "The Cleveland Gem," and as such promises to become historical, being the largest and most perfect gem ever cut on the American Continent. The stone was shown when partly finished to Gov. Cleveland, who was much pleased with the compliment. It will be sent to the New Orleans Exposition. This New World's Koh-i-noor was found at the Cape of Good Hope about eight years ago, and has been owned by English brokers until about two months ago, when Mr. Dessau bought it.

Burger & Co., No. 12 John street, sole importers of the celebrated Potter watches, have recently received an invoice of elegant chronographs, repeaters, etc., of the finest make. There are minute repeaters, five minute repeaters, five minute repeaters with one-fifth second chronographs, and plain watches of the highest order of excellence. Among these goods are some elaborate examples of the science of horology. For instance, one of them is a minute repeater whose face shows seconds, minutes, hours, the day of the week, the day of the month, the month of the year and the phases of the moon, the combination making a perpetual calendar. The moon phases are shown on a blue enameled ground, above which is a full moon in silver, surrounded by silver stars. The Potter watches are known throughout the world as excellent timekeepers, made on honor, and unexcelled in workmanship, while the quality of the gold in the cases is eighteen karats. Of course, watches of the high order of these command high prices, but if one wants an elegant and trustworthy watch, he expects to pay a fair price for it. In addition to these elaborate watches, Mr. Burger carries a full line of the Potter watches in lower grades, all of which are warranted to be reliable timekeepers. Nothing could be more suitable for a Christmas present than one of these fine gold watches.

Miss Caroline Schermerhorn Astor, daughter of William Astor, and great-grand-daughter of John Jacob Astor, was married November 18 to Marshall Orme Wilson, son of Richard T. Wilson. As the bride's presents were, as would naturally be supposed, exceedingly numerous and elegant, we append the published list as an indication of the great variety of articles provided by the trade for such occasions. Among the other gifts to the bride were diamonds from her mother, from her aunt and uncle, Mr. and Mrs. John Jacob Astor, from Mr. Wilson, Mrs. Delano, General Van Alen and others. Then there were several sets of silver spoons, knives and forks; a silver basket, a silver perfumery bottle, silver dishes, silver framed mirrors, silver *repoussé* back mirror, silver candlesticks, silver *repoussé* service five pieces, glass smelling bottle, gold lined syrup pitchers, a ruly pin, silver framed mirror, silver pitcher, hammered gold and silver punch bowl, gold lined silver spoons, silver necklace, gold and china clocks, silver smelling bottle, bronze pitcher, a silver group, hammered silver spoon holder, gold card receiver, gold inkstand with dragons, brass thermometer, silver sugar bowl, gold inkstand, silver finger bowl, silver-backed brushes and mirror, gold-lined punch bowl, solid silver tray with monogram, silver *repoussé* tea service in red morocco case, oval carved silver tray, silver oyster forks; knives, forks and spoons of gold in black morocco case lined with white satin; carved fan with gold ornamentation, cologne bottles, brass clock, antique card receiver, silver candlestick in *repoussé*, silver salt cellars, silver card case with porcelain bottom, silver cream jugs, silver spirit flask, chased silver tray, silver candleabra with candlesticks to match, more silver candlesticks, silver pitcher, a case of two dozen ice spoons in antique design, blue satin case of after-dinner coffee spoons; silver, gold lined, ice cream spoon; gold-lined salt cellars and gold tea spoons. There were many other beautiful and costly presents, but the above is a fair indication of what the jewelry trade did towards equipping the gentle bride for married life.

The Jewelers' Circular Publishing Company has just issued, in handsome book form, an authentic historical account of the Russian reproductions now on exhibition at the Metropolitan Art Museum. The work is profusely illustrated with engravings representing the various articles on exhibition. These are reproductions of art work in metal, the originals of which are jealously guarded in the art museums of Russia. It is only recently that permission could be obtained to copy them, and three sets of the reproductions only were permitted to be made. One of these is in the Kensington Museum, London, one here, and one in Cincinnati. They are perfect *fac similes* of the original pieces, and exhibit the form and designs of the various articles in perfect imitation of the various metals of which they are composed. The history and full description of these has been written by John W. Miles, the well-known antiquarian, and is published with the sanction and endorsement of the Managers of the Metropolitan Museum of Art. The book is interesting, not only as a description of the articles enumerated, but also because it gives us a glimpse of the social conditions existing at the time they were made. It is handsomely printed on fine paper from clear cut types, and is neatly and substantially bound. It will be sent postpaid to any address on receipt of the price, which is \$1. Address The Jewelers' Circular Publishing Company, 42 Nassau street, N. Y.

The following letter, which explains itself, we print as an act of justice to Messrs. Howard & Son:

Providence, R. I., November 8, 1884.

*Editor Jewelers' Circular, Dear Sir:*—On the day of the Cleveland Business Men's demonstration in New York, Saturday, November 1st, our New York office, which we share with a house of pronounced Blaine proclivities, was profusely decorated on the front with placards betraying hostility to the Cleveland movement in a manner which was insulting and indecent. Both members of our firm were away from New York at the time, and the action taken was without our consent or knowledge. Our clerks, who were responsible for the occurrence, were well aware that their employers were strongly in favor of Governor Cleveland, but we, being Democrats in the broadest sense of the word, made no effort to coerce or unduly influence the votes of any of our employees, among which there are fifty voters. Our liberal spirit was taken advantage of and we desire to apologize to the gentlemen composing that grand procession for the insult they suffered in our name. It will perhaps be said by some ill-natured persons that this declaration is made at a very late day, but those who know us will say that among those who were for Cleveland "first, last and all the time" are yours truly,

HOWARD & SON.

We notice that the fashion writers for the daily press are at last beginning to notice the revival of the demand for gold articles for feminine decoration. The following item we clip from a recent issue of the *New York World*: "Bangle bracelets are in style, the most fashionable design being that of a chain and padlock, with a tiny key attached. In cuff buttons there is a decided competition between what are known as the 'lever' and the 'propeller' locks. Both styles are convenient and easy of adjustment, even in the stiffest of cuffs. The all-gold lace pins this season show three styles of finish, known as the 'nugget,' the 'snowflake,' and the 'fiber.' These all give a rough surface. Which is most attractive is a question for each lady to decide, it being a matter of taste. Among the newest things in ladies watch chains are short light chains, three inches in length, with a ball at one end and a swivel for the watch at the other. This ball may prove on opening it a locket or vignette. Some patterns are varied by having gold cubes in place of the balls. Gold jewelry is not very much worn abroad at the present time, but has been revived here. The revival is a welcome one, bringing, as it does, a large number of artistic and original designs in lace, scarf and bonnet pins, bracelets, ear rings and other articles of personal adornment. It has been some years since gold jewelry has been largely worn, owing to the furore for gems, hence its reintroduction in dainty and attractive designs insures a prosperous run."

The *Diamond Fields Advertiser* tells the following whopper: Some few months ago, an overseer, reputed to be in the employ of the Central Diamond Mining Company, Kimberley Mine, managed by some means or other to pass through the searching house with a 457 karat, purer in quality and whiter even than the memorable Porter Rhodes. He was not long in making his "find" known to four noted illicit in camp, who joined together to become possessors of what they knew from long experience to be a thing of immense value, and each of them resolved to pay for the diamond the sum of £750, or altogether £3,000, naturally a very magnificent amount in the eyes of, perhaps, an impecunious servant. These illicit diamond buyers who secured the prize played at cards night and day to pass away the time, soothe their agitated nerves, and principally for the object of considering how the diamond could be smuggled out of Kimberley. The play at cards resulted in two of the four losing their interest altogether in it. The other two managed somehow to get it along with them, without molestation from nasty detectives, to Capetown, and there they sold it to a Capetown firm of illicit diamond buyers for the sum of £19,000, a happy sale to both buyer and seller, considering its immense value. A member of this firm went to England with the gem, and when its exceeding purity and sparkling brilliance became known in Hatton Garden, a great deal of excitement arose, especially among those who were in the secret. Some well known individuals, formerly of Kimberley, organized a syndicate of eight, who purchased the stone at the fabulous figure of £45,000, a ninth share of any increase in the price being still maintained—to this extent, that if the "beauty" realized more than the amount already named, a ninth part of that excess was to be paid to the colonial traders in stolen diamonds, who are in a large way of business in Capetown.

In our fashion article allusion is made to some new styles in pencils, pens, match safes, whistles, etc. Whoever wants to see these goods in endless profusion, and in the latest styles and designs, should drop into the place of business of Leroy W. Fairchild, No. 18 John street. Mr. Fairchild is one of the oldest gold pen makers in the country, and during his many years of invention and manufacture, he has acquired facilities for making goods of this kind that are possessed by no other manufacturer. Among the novelties he has brought out for the holiday trade are exquisite match safes and taper safes of gold and silver in combination, and in gold and platinum. They are of convenient size, strongly made and richly ornamented. They are not only substantial and ornamental, but exceedingly useful. He has also many novel designs in cigar cutters, whistles in every variety—in bottles, chamois horns, gold and silver, in various styles of workmanship, dog whistles, bicycle whistles, and whistles for every conceivable purpose. Glove and shoe buttoners for ladies and gentlemen are put up in a variety of attractive forms; one that is expressly popular is an ornamented gold case, like a pencil case, in which the button hook slides back and forth. In pencils the styles are endless, pencil points springing forth from the most unexpected places. For instance, a miniature champagne bottle in silver has a gold cork which pulls out, and a solid, practicable, pencil stands revealed; from a miniature cannon a spring projects a pencil. There are pencils in imitation of human figures, in acorns and in almost every conceivable form. Some of the cases are beautiful, enameled, others are made of gold and platinum, others with gold and silver in combination, all beautiful in form and workmanship. There are pens, too, of every form and style, with all sorts of holders, to suit every style of penmanship. Many of these things are intended to be worn as charms, others to carry in the pocket. For infinite variety of goods of this character, and for excellence of workmanship, Mr. Fairchild's stock is unexcelled. As he makes all these goods himself, and has obtained patents for many of them, he is prepared to warrant them in every particular.



VOLUME XV.

NEW YORK, JANUARY, 1885.

No. 12.

## THE JEWELERS' CIRCULAR AND HOROLOGICAL REVIEW

*The recognized organ of the Trade, and the official representative of the  
Jewelers' League.*

A Monthly Journal devoted to the interests of Watchmakers, Jewelers, Silver-  
smiths, Electro-plate Manufacturers, and those engaged in the  
kindred branches of art industry.

### SUBSCRIPTION:

To All Parts of the United States and Canada,  
**\$2.00 Per Annum; Postage paid.**

To Great Britain, France, Switzerland, Germany, the West Indies, Mexico, the  
Republics of South America, and Australia, \$3.00 per annum. Postage paid.

 All communications should be addressed to SETH W. HALE, President, THE  
JEWELERS' CIRCULAR PUBLISHING CO., 42 Nassau Street, New York.

 Advertising rates made known on application. 

### A Few Words About Ourselves.

THE PRESENT issue of THE JEWELERS' CIRCULAR brings to a close its fifteenth volume, and it will not, we trust, be deemed out of place if we here say a few words regarding the past and the future. For fifteen years THE CIRCULAR has been published in the interests of the jewelry trade, and we use the term "the trade" in its widest scope and signification, including all industries that are essential to the success of the jewelry business. Recognizing that each branch or department in the trade was a necessary factor, THE CIRCULAR has not sought to give prominence to one over another, or to make itself the organ of any particular element in the trade, or any clique or faction, but has always and steadfastly sought to promote the general good of all persons identified with the jewelry business. Manufacturers, jobbers and retailers have all had voice in our columns at all times, while editorially it has been our aim to advocate all things that were calculated to promote the welfare of the trade in its entirety. This was the purpose, faithfully carried out, of the founder of THE CIRCULAR, and this is the purpose of those who, upon his death, succeeded to the management of this journal. The career of THE CIRCULAR has been a phenomenal one. Started as a small, diminutive sheet, with but slight encouragement from the trade to begin with, it soon demonstrated its usefulness, and the fair and honorable manner in which it was conducted speedily won the confidence of the trade. As its circulation and influence increased, and as its patronage became more liberal, it grew in dimensions until it has come to be recognized as the handsomest journal in the world devoted to any special industry. It has always been the ambition of those in control of it to make THE CIRCULAR the representative journal of the trade, *par excellence*, and to

this end they were liberal in their expenditures to improve, not only its typographical appearance, but the character of its contents, thus giving to its patrons a generous return for the support they have accorded it. To this end the best writers on technical subjects were secured at great cost, and its columns have teemed with instructive articles that have since, compiled in more permanent form, become standard text books in the trade. A glance at the advertising pages of THE CIRCULAR show that it has numerous patrons, while a perusal of the reading matter pages will furnish convincing proof that its advertising receipts have been liberally expended in procuring desirable articles from the pens of experts in the various branches of the jewelry business. And we desire to say here that many of our contributors could not have been induced by a mere money consideration to prepare the scientific articles that have appeared over their names, but were impelled by a love for their particular specialty to put in print the result of their laborious researches. THE CIRCULAR offered them facilities for reaching a class of readers whose acquaintance they were desirous of making, and this, more than the compensation they received, prompted them to write for us. No other journal in the world, probably, could have tempted them, but ours was precisely the medium they desired for imparting their experiences to those who would appreciate them. Whoever has a complete file of THE CIRCULAR and will take the trouble to refer to it, will find that it is a regular encyclopædia of useful information regarding the jewelry trade, and kindred arts and sciences. It is by making a journal of this character that its proprietors have sought to give adequate return to its patrons for the liberal sums they have expended upon it in advertising—if they have been liberal we have sought to give them a *quid pro quo*, by making a representative journal second to no other in the land. Knowing as we do the aims, purposes, ambition and achievements of the founder of THE CIRCULAR, we are at liberty to claim for him that he amply fulfilled his promises to the trade, and gave more than value for every dollar he received on account of the journal he so ably conducted.

As to the future, it will be the ambition of the present proprietors of THE CIRCULAR to carry out the aims and objects for which it was established, by at all times catering to the best interests of the trade in all its branches and in all localities. Much space will be given in the future as in the past, to technical articles prepared by specialists in the various arts and sciences that are tributary to the jewelry trade. The science of horology will be discussed in its various phases by our well known contributor, "Excelsior," and others; special articles upon optics and optical goods, upon engraving, upon precious stones, upon gold and silversmithing and upon various other topics of interest, will be given from time to time; translations from well known foreign authors and scientists will form an important feature of our "make-up," while "Workshop Notes," "Foreign Gossip" and "Trade Gossip" will occupy conspicuous space in each issue. A department of "Fashion Gossip," prepared by a well known lady who contributes fashion articles to the daily press, is a new feature recently adopted, and in it will be treated the fashions

in jewelry from a lady's standpoint, with a view to keeping retail dealers and general readers informed regarding the new styles and novelties that are brought out from time to time—in short, it will be the writer's ambition to keep the public informed regarding what is attractive and popular among the goods that go to make up a jeweler's stock. In our editorial columns attention will be given to the changing commercial features of the business, and such matters of general interest to the trade as come up from time to time will be fully discussed from the impartial standpoint of the general good. Correspondence from the various trade centers, giving the outlook in the different prominent cities will also find space in our columns. But we do not desire to be too profuse in promises—the proof of the pudding is in the eating—but prefer that our work from month to month shall speak for itself. Suffice it to say, that neither labor nor expense will be spared in maintaining the high standard of THE CIRCULAR, and in making such improvements from time to time in its general character as the changing phases of the business or the exigencies of the times may demand. With these assurances we close volume XV., thanking our many friends for their courtesies in the past, and hoping they will continue with us for another year, at least, cheering us by their presence from month to month as we labor to promote their interests.

---

#### Abuse of Credit and Hard Times.

HE WOULD not be a faithful chronicler of passing events or true to his journalistic obligations, who would shut his eyes to the fact that the country is now, and has for the past two years, been struggling through a period of financial depression that has imposed heavy burdens upon all classes. It is fully three years since the business interests of the country entered upon a process of liquidation, but it was during the year just passed that the effects of this were felt with the greatest severity. It took several years to recover from the panic of 1873, but a period of prosperity followed, during which all lines of business thrived, new enterprises on a magnificent scale were projected, universal confidence in everything prevailed, and everybody seemed on the high road to that happiness that is engendered of wealth. So favorable did all the conditions seem, that men were tempted to launch out into the stream of speculation, and, as a natural result, the country soon became burdened with the old trouble that has led to every financial crisis we have passed through, inflation of all values, over-speculation and over-production. Property having an actual value was "boomed" to fabulous prices, while speculative enterprises were given a fictitious value, that there was no hope of realizing. Mythical railroads, beginning nowhere and ending in space, were projected by visionary schemers, bonded for fabulous sums, stock issued and sold on the exchanges to a credulous public; mining schemes that had no basis but in the imagination of their projectors, were similarly launched; there was nothing, apparently, that could be suggested that the public would not take hold of and pay its solid money for. Of course, this could not last; a reaction had to come that should bring business back to a basis of actual values. It came first with the bursting of the wild mining schemes, resulting in the closing of the New York Mining Exchange; this was soon followed by a tumble in speculative stocks of all kinds, many of which were eventually thrown out of the exchanges as absolutely worthless; valuable properties suffered in sympathy with the speculative ones, and stocks that were really paying liberal dividends fell below par; failures of banks and bankers necessarily accompanied this terrific shrinkage of values, and a panic of magnificent proportions was, for a time, imminent; it was only prevented by the fact that the period of liquidation had been an extended one, and the water had been pretty nearly squeezed out of all representatives of values. During this reactionary period capital became frightened, and banks and

bankers extremely conservative; money was plentiful but locked up safely in the banks, whence it could be obtained only on "gilt-edged collateral;" the financial institutions had a plethora of money, and soon began cutting down the rate of interest on deposits, or refusing to pay any because they could not make satisfactory investments, and the hard times became general. The shrinkage in values that has taken place in the past three years amounts to hundreds of millions of dollars, exceeding largely, it is said, the losses by the panic of 1873 and following years. While this shrinkage has not excited such a sudden general revolution as panics heretofore have, yet there is scarcely a person in the land that has not been affected by it to some extent. Business has become almost stagnant, manufacturers have been forced to limit their productions, thousands of working men have been thrown out of employment and distress and suffering have been everywhere apparent. To crown all came the presidential canvass, diverting many from their legitimate avocations and unsettling everybody, as such campaigns always do.

The cause leading to the over-inflation of the speculative bubble, resulting in subsequent financial depression and the present hard times, was the general abuse of the credit system which lies at the foundation of our business enterprises. Credit is a necessity in business, and when it is controlled by good judgment and wisdom it is a blessing to all classes; but when credit is abused and through it public confidence is destroyed, it becomes a curse, bringing ruin and disaster to thousands. It was by the abuse of credit that visionary railroad and mining schemes, and other purely speculative enterprises were "boomed" into public confidence; they had no substantial foundation of actual value to rest upon, but were conceived in fraud and brought forth in iniquity for the sole purpose of swindling the public. By misrepresentation they obtained credit with which to gain the confidence of the public and gather in its dollars. When these speculative bubbles were pricked there was a sudden collapse, and confidence received a shock that caused its withdrawal from legitimate as well as speculative enterprises and from business in general. If actual values formed the basis of credit in this country, such speculative bubbles could never be blown up to such magnificent proportions as they too frequently assume. When an existing railroad, having a legitimate business and good prospects for the future, asks for a loan, it has something substantial to offer as security; but when the prospectors of a scheme for a railroad that exists only on paper asks credit to the tune of millions of dollars, the general public has no business to meddle with it; capitalists and speculators may put their money in it if they choose, but men engaged in ordinary business should keep hands off, and until it has something tangible in the way of a road, its stock should never be listed on any of the exchanges or offered to the public. During the mining fever, men made a business of locating mines, buying a few acres of ground in some mining state, then forming stock companies with a fabulous capital—on paper—getting the stock listed on the exchange and selling it for what it would bring, thus realizing large sums on an investment of a few dollars for worthless land and paper on which to print the stock. The blind, unreasoning manner in which credit is given and fraudulent speculations encouraged, is responsible for these swindles, and is responsible, consequently, for the existing financial stringency and business depression.

The jewelry trade not only suffers in common with the general public from the popular abuse of the credit system, but it has grievances in connection therewith peculiar to itself. It has been frequently said that in no other line of business is credit given so unthinkingly, so extensively and with so little inquiry as in the jewelry trade. Recent disgraceful failures are proof of the truth of this assertion. Instances have recently occurred where dealers in small cities have obtained from \$30,000 to \$60,000 worth of goods on credit and failed within thirty days thereafter—or as soon as they could select their preferred creditors and make other arrangements for disposing of the goods. A little inquiry would have revealed the extent to which these men were buying goods, and also the fact that



half the amount would have been a liberal stock for their locality. The purchases they were making were evidence that fraud was intended, but no one took the trouble to make inquiries—all the men had to do was to order the goods and they got them. Probably they will compromise eventually for a few cents on the dollar, thus re-establishing their credit, resume business and repeat the failure dodge after a reasonable lapse of time. The number of retail dealers in the country runs well up into the thousands; probably the names of ten or fifteen thousand, perhaps more, could be obtained from the jobbers in this city; being thus known as dealers, any one of them could come East and obtain goods on credit to an almost unlimited extent; all that is necessary is a good plausible story, for there will be little inquiry into the truth of it. Matters have got to that point where it is scarcely necessary for a jobber or retail dealer to have any money invested in his business; a plausible tongue and unlimited cheek will get him all the goods he wants on credit; if he can sell them to advantage, well and good; if not, let him fail and make his own terms with his creditors. They take all the risk and he makes the profit, if there is any. If his paper is nearing maturity, and he has any scruples about failing, he has only to ask an extension to get all the time he wants. In fact, he can get an extension before he gets the goods, if he desires; he has only to ask to have his bills dated ahead to get six months credit on a four months note, subject to renewal when desired. Finally, as a last resort, failure and compromise are popular methods for getting the best of creditors.

This would seem to be a good time to reform the system of credits in the jewelry business. Owing to the depressed condition of business, there are probably fewer goods out unpaid for at the present time than usual; the times have been so unpromising that dealers have not been liberal buyers during the past year. When trade improves, as it soon must, it would be a good time for the creditor class to insist that buyers should be at least part owners of their stock; that they should have sufficient money of their own invested in their business to afford their creditors a tangible hold upon them; if they have confidence enough to put their own money into the business the jobbers can afford to take some risk, but it is too much to expect them to take it all. It would be well to institute more rigid inquiries relative to the standing, business habits and prospects of every one asking credit, and to be governed accordingly. Then the abuse of dating bills ahead should be abandoned; it is subversive of all business principles and should not be tolerated any longer. Let a four months note mean four months and not six months. These matters rest entirely in the hands of the manufacturers and jobbers; they have but to lay down the rules governing credits and dealers will make their calculations accordingly. Abuse of credit is the evil from which the country at large is suffering at present, and every business man owes a duty to himself and his fellows to do all in his power towards bringing about a reformation.

---

### The Outlook for Business.

THE HOLIDAY season has come and gone. It brought with it a fair amount of trade, but it came reluctantly, hanging off till the last moment, and contenting itself with as limited a volume as was consistent with the joyous season of the year. For a brief space, at least, there will be a lull, and manufacturers, jobbers and retail dealers will have abundant opportunity to take account of stock, post their books and figure up their profits on the year's business. If reports are true, they will not be burdened seriously with the wealth they have accumulated during the year, but, on the whole, business might have been much worse. The trade can congratulate itself that it has held its own, and, indeed, is a little better off than many other lines of industry. Failures in the trade during the year have been few compared to those that have occurred in other branches of business, and if fewer goods have been sold than usual,

there have been fewer made and there are less to carry over. A dull year was foreseen by most manufacturers and they governed themselves accordingly, reducing their product to what would suffice for a limited demand and lopping off their expenses proportionately. Probably not a dealer in the trade expected to do a large business during the year just passed, and therefore he is not disappointed. We have discussed at other times the causes that have existed for several years for the general depression of business, and at various times have commented upon the business situation as it appeared to us. We have never taken a lugubrious view of affairs, nor have we been unduly hopeful; while warning the trade against over-production and over-stocking, we have expressed the belief that, while trade would seem dull the business of the year would average fairly well. We cannot expect prosperity all the time; there will be good years and there will be bad years; the judicious man will so gauge his affairs that the average, year in and year out, will be in his favor. But if he makes money fast one year and spends it as fast as he makes it, he will be very apt to be badly squeezed when the bad years come. Life is made up of averages, and they are quite as well defined in business matters as elsewhere.

The signs of the times indicate a fair business year for 1885, and we shall be much mistaken if it is not a marked improvement over that of the year just closed. In the first place there has been a period of financial stringency extending over three years, which is about the limit of these hard times epochs that are of periodical occurrence. They are followed invariably by a healthy activity that is gradually stimulated to a speculative fever, then comes a panic. These are financial fluctuations that are very well defined, and we think we have reason to hope that the time for the reaction has come. It is always darkest just before dawn, so runs the proverb, and if this holds good in business matters, the dawn should be near at hand. The political barometer does not portend threatening weather, nor does it indicate any particular change. The excitement of the presidential canvass having died out, everybody accepts the result of the election with good grace, and expresses a willingness to aid the incoming administration in putting our national affairs upon such a basis as will improve the condition of the country and develop our commercial relations with other nations. It is not to be apprehended that the change from a Republican to a Democratic administration or *vice versa* can now or at any future time be attended with dire results—our nation is too firmly planted and the government too stable to admit of such a supposition. On the contrary, a change in our political rulers from time to time is likely to be a benefit than otherwise by bringing new men and new ideas to the front. Thus far the out-givings of President-elect Cleveland have been of the most pacific nature, and have won for him the commendation of even his political opponents. So this bugbear of a campaign lie, "that a change of administration was a threatened revolution," may be put aside as the ravings of men who had lost their mental equilibrium during the excitement of a political contest. So far as the political outlook is concerned, it promises well for the business interests of the country. Then the very fact of our having passed through a dull season is good reason for anticipating an improvement in business at an early day. Dealers who have been such modest buyers have been working off their old stock, and for several months have only ordered such new goods as the demand required. They are, as a consequence, reduced in stock, and will embrace the first favorable indication of a coming demand to lay in fresh supplies of new and attractive goods. Jobbers, too, have allowed their stocks to run down, and will watch keenly for a demand that will warrant them in replenishing. Manufacturers are in good condition to increase their product, having everything in readiness to manufacture standard goods and novelties as occasion may require. The trade, in fact, is not suffering from over-production or from being over-stocked, and any demand that may come will give an impetus to trade that will be felt by all. We do not anticipate that such demand will come to any great extent before the

middle of the year. Congress is in session, and that is always a wet blanket on business; then comes the inauguration in March, and, simultaneously, presidential cabinet making. When the President is fairly installed in office and the new heads of departments are warm in their seats, we may fairly anticipate that the country will settle down to business, and that the united efforts of business men will secure a return of public confidence, the one thing needful to insure industrial prosperity. We venture the opinion, therefore, that there will be an excellent fall trade, that it will set in early and be supplemented by an unusually active holiday trade for the season of 1885-6.

---

### A National Bankruptcy Law.

WE HAVE before urged upon the trade the importance of bringing to bear upon Congress all the influence it can command to secure the passage at this session of a national bankruptcy law. Ever since the repeal of the old one, business men have been seeking to secure the adoption of a new and improved law, free from the defects of the old one, that should make the forms of bankruptcy proceedings uniform in all the States. Two years ago Judge Lowell, of Massachusetts, prepared a bill that was submitted to the various commercial exchanges of the country and received their approval; last winter it was passed by the Senate, but in the House it was not reached before the adjournment. An attempt was made to take it up out of the regular order, but this required a two-third vote and it lacked a few of the requisite number. It now lies on the Speaker's table with little prospect of its being reached at this session unless the business men of the country raise a vigorous demand for it. The action of last winter showed that there was a small minority in the House opposed to the Lowell bill, but this opposition would, no doubt, yield to the demand of active business men. It is, as we understand, based upon the old doctrine of States' rights, which would concede to each State the right to regulate the business conditions of its own citizens; but trade and commerce recognize no State boundaries at present. In former days, before the introduction of railroads and telegraph lines, inter-state commerce was exceedingly limited, and State laws were sufficient for the regulation of all business transactions within their respective borders. But now the commerce between the States has assumed such vast proportions that the diverse State laws assuming to regulate it have become burdensome, and should be supplemented by national laws that secure uniformity of practice in all the States and Territories. Especially is this so in all matters pertaining to credits. The great bulk of business in this country is done on credit, and unless the creditor class is properly protected by laws that are universal in their application, there will come a restraint upon the system of credit that will prove a serious embarrassment to the debtor class. For the lack of a national bankruptcy law the man who sells goods on credit assumes risks that ought not to fall to him. To avoid them, he must be familiar with all the laws of all the States bearing on debtors and creditors, in order to know what means of redress they afford him in case his debtor endeavors to avoid his obligation. Usually the laws of each State give its own citizens some advantage over outside creditors, and provide some loophole for their escape. So clear has this been made to the creditor class that it is seldom one attempts to collect by legal means a debt due him from a citizen of another State in the courts of that State. He may embarrass him and force him to a compromise, but the debtor can lead him a long chase through the courts if he chooses to fight rather than to pay.

This is all wrong and a great embarrassment to business men. A man selling goods in New York to a citizen of Maine or Texas, ought to be assured that the same laws governing collections or providing for bankruptcy that are operative in New York will hold good in either of those States. A national bankruptcy law is a necessity in business, and no effort should be spared to secure one from the

present Congress. Efforts are being made by various boards of trade and commercial exchanges to concentrate the influence of business men upon Congress to secure a new bankruptcy law, and the jewelry trade, which is a great sufferer from the lack of such a law, should be prominent in appealing to Congress for the relief as such a bill would give. There is no time to lose if anything is to be done at this session of Congress, for there are but a few weeks before adjournment. So much business has accumulated, that if done at all, the bill will have to be taken up and passed out of its regular order. There should be active and vigorous work on the part of those interested.

---

## Gossip of the Month.

FAREWELL to the Old Year! Welcome to the New! While it is considered unwise and impolitic to speak disrespectfully of the bridge by whose aid we have crossed the stream in safety, yet we may, without impropriety, earnestly hope that the year 1885 will be a more prosperous business year than its immediate predecessor. Indications that it will be are to be found on every side. The country is in a state of peace, the harvests of the past year were bountiful, money is plentiful, speculation has largely lost its fascinations for the masses, and there everywhere seems to be a determination to settle down to the legitimate business of life. The great depreciation in securities of all kinds that has taken place in the past two years has left capitalists, banks and other monied institutions with millions of dollars on hand which they cannot invest advantageously; trust companies and banks have reduced their rate of interest on deposits, or foregone it entirely, till many a man who has acquired a competence has found the interest earnings of his capital insufficient to meet his expenses, and he has been forced to draw upon his principal to make up the deficiency. As a consequence of this condition of affairs, capitalists are looking eagerly for investments, and with the first symptom of a restoration of public confidence the money now locked up and earning nothing will be released and turned into the channels of business enterprise. As an indication that the business outlook is improving, we have observed, while crossing the ferry daily, that every steamship leaving this port goes out loaded clear down to the "Plimpsoll" line, while those arriving from abroad float high in the water, apparently having no cargoes whatever. Large shipments of gold from Europe to this country in payment for these heavy freights going abroad are matters of daily record in the financial columns of the daily papers. The balance of trade is, therefore, largely in our favor, a condition of affairs that is a material factor in our national prosperity, and is one of those straws that indicate that the commercial breezes are setting in our direction. The new year comes in under favorable auspices, and with a fair promise of a good business year.

\* \*

\* \*

\* \*

THE books for 1884 are now closed and the accounts are being made up. It would be useless to contend that it was a year of great prosperity, or that it was a satisfactory one to business men in general; but that it was such a disastrous year in the jewelry trade as the chronic growlers would have us believe we are not prepared to say. We do know that the general complaint for several months was that business was dull, and there is no gainsaying that statement, but we have become so used to hearing this complaint, even in prosperous years, that we now make a liberal discount. But amid the general outcry against dull times we have met a few manufacturers and jobbers who, when we asked "how is business?" invariably replied "we have nothing to complain of; there is no rush, but a fair average amount of orders." One of these, a manufacturer of

gold goods, told us a week ago that his firm was surprised at the total of their November business, the volume of which was fully equal to that of November a year ago. He said they had been pegging away, doing a little something every day, but continually thinking business was dull, till they came to foot up the month's transactions, when they found it was not \$1,000 below that of November, 1883. But there was less profit, because competition has been so great that prices could not be maintained. A gentleman identified with one of the large silverware houses told us substantially the same thing, and from these and other statements we reach the conclusion that the year's business, while not remarkably profitable, was not particularly disastrous in the jewelry trade.

\* \*

\* \*

\* \*

BUT there is one thing we believe must be accepted as a basis of business for a few years at least, and it is that, in all kinds of business, dealers must be content with a smaller margin of profit than they have been accustomed to. One effect of the liquidation the country has been passing through has been to break down prices. All our agricultural products are selling in the market at lower prices than have ruled in years before; all staple manufactured goods are away down in price; everything is at low ebb except the necessities of life—everything but that we eat and drink. All goods in the jewelry line have also been subjected to large reductions, and, as a consequence, the profit in making and handling them will be less. If manufacturers will keep this fact in mind, and regulate their expenses accordingly, they will still find their business a desirable one, but they will have to spend a few more years in business than they otherwise would. The worst feature of this phase of the business outlook is the effect it will have on the workingmen. Capital can always protect itself in some way, but the working class, that is dependent upon daily earnings, has no recourse but to accept such wages as the conditions of trade will warrant. Already, in many lines of industry, wages have been reduced from five to twenty per cent., and, in most instances, the working people, seeing the necessity for it, have readily acquiesced in the reduction, and in a few instances only have there been strikes. But the working classes have this to console them, that if they earn less it costs less to live, for there have been remarkable reductions in almost everything except, possibly, meats, butter, eggs, and some luxuries that we would all be better off without. The prospect, however, for steady employment for regular mechanics is considerably better now than it was six months ago, when many of the factories and mills were obliged to close. Some of these have resumed operations, and some that were running one or two days a week have doubled their working time or are running to their full capacity. In dull seasons the greatest forbearance between capital and labor is necessary, and if there is on both sides an intelligent comprehension of the situation and due consideration of the rights of each, the hardships inherent in the situation may be made lighter for all.

\* \*

\* \*

\* \*

THE number of failures last year was unusually large, as was to have been expected from the prevailing depression in business, but the number of failures in the jewelry trade was small in comparison to the whole. Of course there were a good many, and some most rascally ones, but the legitimate dealers, who were earnestly striving to do an honest business but failed in spite of their best efforts, were fewer than might reasonably have been expected. This may be taken as a sure sign that the retail trade throughout the country is in an excellent condition, that dealers are not overstocked with goods for which they owe jobbers and manufacturers, and that they, like business men in general, have been steadily liquidating their obliga-

tions. These are good indications, promising a liberal volume of business at such time as the demand may become more active. Thus the dull times have their compensations. One of the worst things that can happen to the trade is to have the retail dealers overstocked in a dull season; they are cramped and worried to meet maturing paper, and hampered by a stock of goods for which there is no demand, and which rapidly deteriorate on their hands, or is rendered *passé* by the introduction of new styles; then, when business becomes more active, the dealer feels that he must work off his old stock before ordering new goods, and so the burden falls back upon the shoulders of the jobber and manufacturer. The fact, however, that they have pulled through the hard times thus far with so few failures speaks volumes for their present condition and promises well for the future. For one to obtain a fair idea of the prospects for business, he must watch not only his own field of enterprise but all others. All lines of business are interdependent, and when the dry goods and hardware trades are active, the cotton and woolen mills fully employed, and other branches of business "booming," it may be taken for granted that the jewelry trade is not far behind. We observe by the commercial papers that a steady improvement has been going on for two months in the produce market; that dry goods are moving more readily; that the cotton and woolen mills are increasing their production regularly, and will soon be running to their full capacity; that the shipments of our agricultural products is increasing; and that, in fact, all branches of business are manifesting increased activity and are feeling hopeful. This means that some of the surplus money that has been tied up so long is finding opportunities for employment, and will soon be freely distributed among the masses. This is one of the first symptoms of a reaction that must always follow a period of stagnation. In the course of a few months we expect to see a largely increased activity in the jewelry trade.

\* \*

\* \*

\* \*

REPOUSSE brass work has become very popular in this country for decorative purposes since it has been taken up by amateurs. But in its artistic possibilities it can hardly equal hammered iron. The latter metal is too stubborn for manipulation by amateurs; but why should not the art be revived by the metal workers? In France, admirable results have been attained in this direction, including the production of the most delicate filigree jewelry. Our metal workers are largely employed in the production of artistic decorative work, and ornaments of all kinds, for parlors, club rooms, hotels, etc., furnish elegant exhibits of their skill. What they may yet be able to accomplish with iron remains to be seen.

\* \*

\* \*

\* \*

THE demand for electrical clocks is spreading, and we note that they have made their appearance in New Orleans and one or two other prominent cities. In New York there is a company duly chartered that makes a business of putting up these clocks, which are connected by wires with a central timepiece which, by means of electricity, marks the time on each clock with which it communicates. The gentleman who organized this company and furnishes it with brains, was the inventor of a fire alarm telegraph, and in developing a means of recording in the engine houses the number of any box from which an alarm might be sent, found that he could utilize his method for registering time upon any number of clock dials, hence the electrical clock company. By the same system he communicates messages from the occupants of rooms in hotels to the clerk in the office. Thus, if a lodger wants a pitcher of ice water, instead of ringing a bell, waiting for a waiter to climb up to his room, take his order, go for the water and return, he touches an electrical button, and instantaneously the fact is recorded in the office that "No. 1,001

wants ice water," and a waiter is dispatched with it. By touching another button he can summon the chambermaid, order fresh towels or intimate that it is time he was supplied with his matutinal cocktail. But the clock business pays the company best, and thus far its attention has been turned to their introduction rather than to the propounding of electrical conundrums to hotel clerks.

\* \*

\* \*

\* \*

SPEAKING of the fire alarm telegraph, doubtless manufacturers in the trade are vigorously importuned by agents of hand grenades for fire extinguishment. Don't buy them. They are a delusion and a snare. One bucket of water is worth more than a dozen of them, and one ordinary fire extinguisher worth more than a car load. The grenade is a glass bottle that contains a chemical compound for putting out fires. The theory of their use is that they are to be thrown at an incipient fire, and, on their breaking, the flames are instantly subdued. Very pretty in theory, but in practice they don't work. It requires an expert baseball pitcher to throw them successfully, half the bottles refuse to break, and others break when not wanted from the pressure of the chemicals inside, and when they do break and release the liquid it is no more effective than so much water. Then, too, fires have a bad habit of occurring where they cannot be reached conveniently, and you might throw grenades at them half a day without once hitting the flames. If you are thinking of buying grenades, our advice is—don't. Supply yourself with buckets of water at one-tenth the cost and see that they are kept filled.

\* \*

\* \*

\* \*

IT IS unfortunate that the United States is not a party to the dividing up of that portion of Africa explored by Stanley that the English, German and French governments propose to appropriate to themselves. They want it for colonizing purposes, and to afford an outlet for their surplus productions. What a glorious thing it would be for the jewelry trade if our government could get a slice of it. How those unclothed natives would rejoice in the gold bracelets, for instance, for their arms and legs that our factories could furnish; what a magnificent opportunity for supplying rings for the native fingers and noses, and jingling bells for their toeses, harpoons to fasten up their hair, and every variety of pin for holding up those garments so universally worn which supply the place of the triangular appendage usually accompanying civilized infants; what an outlet is here for those patent fasteners bearing the inscription "Baby Mine," "Mother's Pet," "Father's Joy;" and what a christianizing effect it would have to see a whole nation of savage blacks swaddled in breech cloths bearing such touching mottoes. And what a range there would be for the display of our home talent in adorning the dusky Eves of that far away land. Since jewelry has taken on so largely the forms of flowers and leaves, they could be supplied with anything in this line, from an apple blossom to a fig leaf. Here is an outlet for surplus production that seems to have been overlooked by the powers that be. Our claim to a part of this newly discovered territory is as good as that of either of the European powers, for was not Stanley formerly a reporter for the *Herald*? and was it not in that capacity that he first invaded Africa? The new administration should look into this matter, and, if our rights are being ignored, our fleet should be at once dispatched to the African coast with instructions to bombard the first village of mud huts that is sighted. Our commercial interests must be protected.

\* \*

\* \*

\* \*

FROM a paragraph that will be found in our department of "Trade Gossip" this month, it will be seen that several western railroads

have entered upon a high-handed course of discrimination against the commercial travelers for jewelry houses. Some half a dozen of them have combined in issuing a notice that they will not hereafter receive, check, store or in any manner assume any responsibility whatever for trunks, sample cases or packages carried by travelers in the jewelry interest. Agents of these roads are instructed to refuse to receive any baggage of this description. No reason for this outrage upon a legitimate class of business men is stated in connection with this order, but it is supposed to be based on the fact that the baggage of travelers for jewelry houses is unusually valuable, and that, in case of its loss, the companies have to pay for it. Well, why should they not pay for it? They are common carriers, and charge for the transportation of baggage in the price they receive for carrying its owner; for every trunk destroyed that they are required to pay for they are paid for transporting thousands on which they make a profit. Do they expect their business to be all profit, and never to incur contingent losses? Insurance companies insure property in large sums for very small premiums, and out of the aggregate sum thus collected by them they are enabled to pay such losses as occur. This is precisely the situation with the railroad companies; they have been taking the money of commercial travelers for years in small sums, and have made a fair profit in doing so; why should they "kick" when they are occasionally required to pay a loss, if they ever are? But, as common carriers, we doubt if they have the legal right to make this broad, arbitrary discrimination against a particular class of their patrons. We should like to see the matter tested in the courts, and hope some one who is injured by a refusal to accept his baggage will bring suit for damages. The effect of this order will be to cause travelers to send their baggage by express, entailing heavy cost and great loss of time. Carrying his baggage in the ordinary way, a traveler is often able to visit three or four places in a single day, for he can put his trunks on any train that passes; under the new order he must wait the convenience of the express company to deliver his baggage, and will seldom be able to visit more than one place a day, as the transportation of his baggage will depend upon the frequency with which express trains are run, usually one each way daily on the western roads. Thus he will have to pay express charges, extra hotel bills, and consume from a third to a half more time in making his trips. Some of the prominent firms in the trade have offered to waive all claims for damages if the order is rescinded, but it is reported that this offer has been declined, on the ground that such waiver would not be valid, the companies being responsible notwithstanding it under the laws relating to common carriers. This order may be enforced temporarily, but it certainly cannot be maintained for any length of time. Congress is now considering this subject of inter-state transportation, and eventually will pass such laws regarding it as will prevent such outrages as this being perpetrated upon an honorable class of business men. The Supreme Court of the United States has decided that a state has no right to discriminate against manufacturers or dealers from other states in favor of dealers within its own borders, and we do not question but the same court would give judgment for damages against any railroad that enforced an order of this character against a particular class of its patrons. We hope there is pluck and back bone enough in the trade to make a fight against this gross imposition.

\* \*

\* \*

\* \*

A MOVEMENT for the abolition of the duty on raw materials has been started by manufacturers in New York and vicinity, about fifty of whom recently organized an association and adopted a resolution demanding "the abolition of all duties on raw materials, in order that we may compete in home and foreign markets with other manufacturing nations not one of which taxes raw materials." The association is known as the Manufacturers' Tariff Reform League, and its members are wire, lead, woolen, sole leather, clothing, and other

manufacturers. The jewelry trade ought to be represented in this organization. If they are to compete in all parts of the world with foreign manufacturers they ought to be permitted to buy the material that enters into their products as reasonably as their competitors can—at least our own government should not impose extra burdens upon them.

\* \* \*

\* \* \*

\* \* \*

TRAVELERS returning from Europe are loud in their complaints at the delay and inconvenience to which they are subjected after reaching this port, in consequence of the regulations requiring all passengers to be landed at the new barge office instead of permitting the steamers to go directly to their docks. Passengers are taken off the steamer, with their baggage, by transfer boats run by contract, which are inadequate for the purpose. Sometimes, when two or three steamers arrive simultaneously, some of them are obliged to wait in the lower bay till a transfer boat is at liberty. The conveniences for handling baggage at the barge office are insufficient, and are in the hands of a local politician who is noted for looking out for number one. A committee of the Chamber of Commerce has recently reported that the new system is cumbersome, dilatory, of no advantage to the government, and imposes unnecessary hardships upon travelers. They recommend a return to the old system of landing passengers on the various docks of the steamship companies. The jewelry trade furnishes a greater number of foreign pilgrims than any other industry, and they are unanimous in condemning the present system of dealing with passengers on their arrival in this country.

\* \* \*

\* \* \*

\* \* \*

WE HAVE alluded heretofore to the desire expressed by some members of the trade for the formation of a Board of Trade. At various times this suggestion has been made and attempts to perfect such an organization have actually been entered upon, but success has not crowned these efforts. Such an organization, to be effective, should include in its membership a very large majority of the trade, and should have the power to formulate rules and regulations the observance of which should be imperative. But we greatly fear this never can be accomplished. There are too many incongruous elements in the trade, and interests of too great diversity to warrant the hope that such a degree of harmony could be secured as is necessary to the success of any organization of this character. The very character of the trade, including as it does so many of the arts, and such a variety of commercial interests, precludes the possibility of its ever delegating to a central organization the power to regulate the methods and means of transacting the business. It is only where there is a perfect unity of interests involved that such power can judiciously be conferred upon a representative body. In the jewelry trade the interests of manufacturers, jobbers and retail dealers are substantially identical, yet the attainment of the desired end is very largely a matter of individual judgment and decision. Certain general rules might be agreed upon for the guidance of manufacturers, others for jobbers and still others for retail dealers, but no code of business, morals or ethics can be laid down that will apply to all. The Jewelers' Association serves a good end because its membership is confined to those whose interests are so nearly identical that such rules as they have can be observed by all and are burdensome upon none. But this is not like a Board of Trade; it is more in the nature of a bureau of information, furnishing to its members important data for their guidance. Throw this open to the trade in general and its usefulness would be destroyed at once. Its field could, possibly, be enlarged somewhat with beneficial effect, but to make its membership too large would be to introduce incongruous elements, and make it cumbersome and unwieldy. There may come a time when organi-

zations of a commercial character may be desirable in the different well-defined branches of the trade, but a Board of Trade to represent all interests seems to be an impossibility.

\* \* \*

\* \* \*

\* \* \*

WE ARE informed that there is less desire than heretofore manifested by buyers to demand those special concessions that have been insisted upon by them in the past, and had grown to be serious evils. Fewer of them request to have their bills dated ahead, and less goods on memorandum are required. One jobber informed us recently that he had been obliged for years to carry from \$20,000 to \$30,000 worth of goods in excess of his ordinary requirements, simply to fill orders for goods on memorandum. Of late requests for such favors have fallen off fully one-half, but whether this is due to dull times or to the combined efforts of jobbers and retail merchants to make this burden as light as possible he was unable to say. As to dating bills ahead, many jobbers have determined not to do this in future on any account, preferring to sacrifice some patronage if necessary to continuing a practice that is as unwise as it is unbusinesslike. There is no reason why the jewelry trade should be burdened with practices so unwarranted any more than any other line of business, and it will be much better for it when it so reforms its system of credits as to do away with all abuses of this nature.

\* \* \*

\* \* \*

\* \* \*

WE DESIRE to direct the special attention of all lovers of artistic metal work to the very important and beautifully illustrated series of articles now being printed in our columns on the Russian Reproductions which are on exhibition at the Metropolitan Museum of Art. This is one of the most interesting collections of examples of ancient metal work ever brought to this country, and is attracting daily the attention and admiration of thousands of visitors to the museum. The articles descriptive of this collection were prepared especially for THE JEWELERS' CIRCULAR by John W. Miles, of the Meriden Britannia Company, the well known writer on antiquarian subjects, with the permission of General di Cesnola and the directors of the museum. It is the only authentic historical description of the collection that has been written, and as such is endorsed by the directors of the museum. The series of articles have been compiled in book form, neatly printed and bound, and are for sale at the museum by permission of those in charge. Copies of this work, which should be in the library of every student of art, may be had by addressing this office and enclosing one dollar.

(Copyright, New York. All rights reserved.)

Russian Reproductions

At the Metropolitan Museum of Art.

[BY JOHN W. MILES.]

Continued from Page 354.



LASSING\* together the few antique Roman pieces which I have selected from the Museum replicas, we may give our attention for a moment to the silver vase illustrated in figure 13, and with the full scenes, on a slightly smaller scale, in figure 14. This was found at the same time and in the same place with the silver pail which has been noticed. Its height is 10 vershoks and it weighs 12 livres. In consideration of its imposing character and the intrinsic value of its material it excels the silver pail, but, unfor-

\* The above initial is from the bible of Charles the Bald of France (ninth century). I have substituted, however, in place of the round ornament in the center one of the little plates of gold previously mentioned as serving for dress decorations among the Scythians. It represents two women dancing.

tunately, its artistic excellence is far inferior. The work upon it, although a mass of details and very elaborate, is coarse and poorly executed. It has, however, one remarkable characteristic in that it is, with the exception of the Centaurs and the small cylindrical neck, of one piece, which render the *repoussé* work upon it very extraordinary. The two Centaurs, which serve as handles and carry each an amphora-shaped vase, match the style of the piece perfectly and

in driving a stag and doe into a net guarded by a young boy. The latter personage is peculiarly dressed in a cowl which covers his head and shoulders somewhat like the *cucullus* which we see worn sometimes by the Persians. Upon the base is represented three marine monsters, the horse, the panther and the goat, each carrying a Nereid almost nude. One of the Nereids is engaged in arranging her hair, while the other two hold each a scarf distended by the wind.



Silver Vase, Figure 13.

were probably made by the same artist. They are not, however, a part of the vase, but simply attached or applied in a temporary manner. The small cylindrical neck, which forms the only opening, is ornamented with scales and has a boss similarly worked in foliage. The superior part of the vase offers the representation of a chase in two groups. In the first group we see a wild boar attacked by the hunters and three dogs, and in the second a hunter assisting his dog

Between two of these figures we see an open shell. The middle of the vase is very elaborately decorated with three groups depicting combats between Greeks and Amazons. The first is composed of two Amazons and one Greek. The latter person is on the point of piercing with his lance an Amazon who has fallen to the ground, while her companion, mounted, threatens the Greek warrior with a battle ax. In the second group we see another Amazon, also mount-

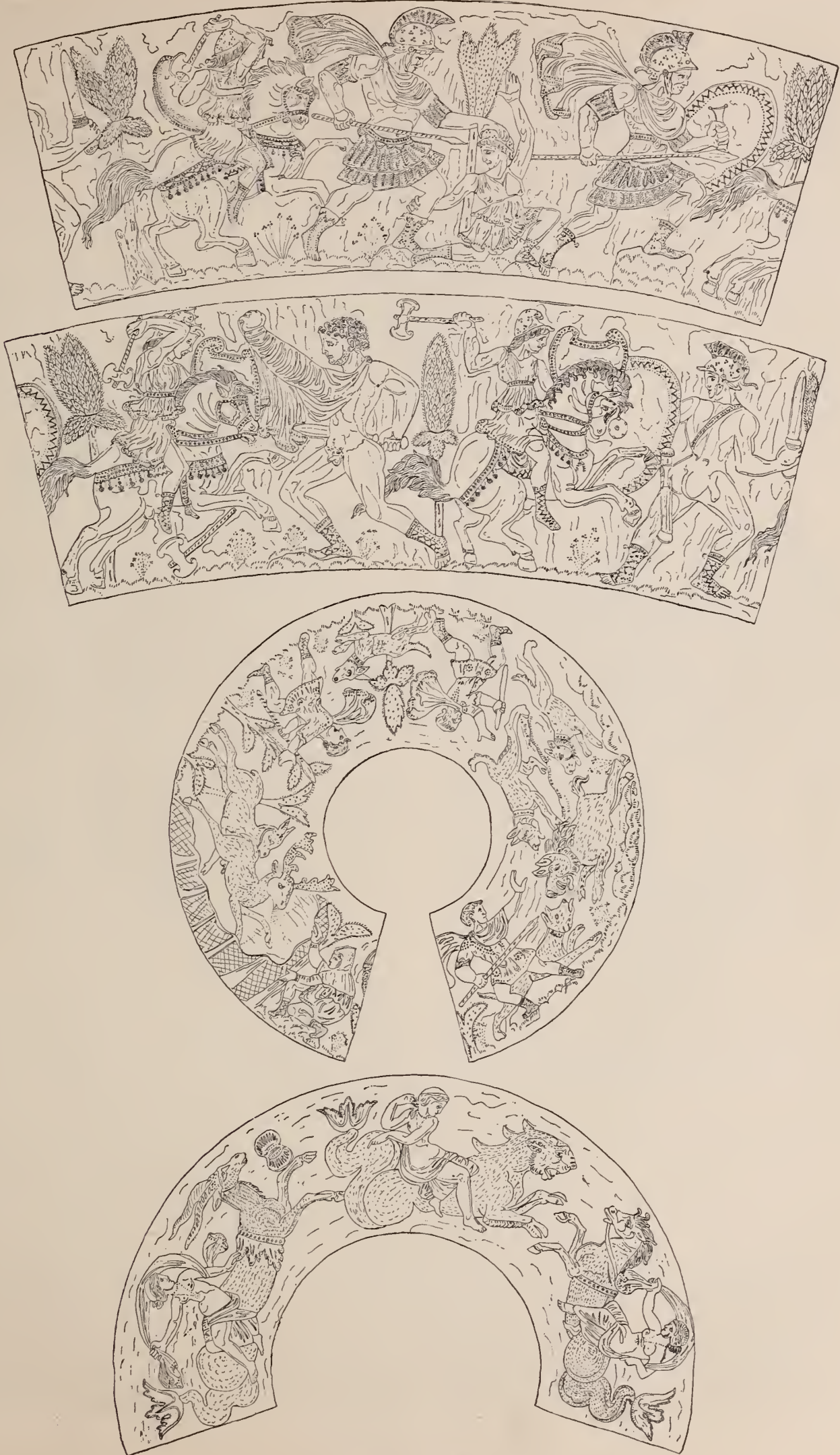

Detail of Vase. Figure 13.

ed, attacked by two Greeks, one of whom is completely armed and the other bearing only the *chlamys* and a sword. The third group, concluding the series, represents a mounted Amazon fighting a Greek foot warrior. The plain upon which these combats occur is strewn with flowers and trees resembling the cypress. The most noticeable point in these scenes is the highly ornamental character of the vestments worn by the combatants and the harness of the horses. These are very richly worked with most elaborate details.

The existence in ancient times of female warriors is no myth. We find such women among the early German tribes and still earlier among the Sauromatæ, one of the branches of the Scythian nation. The physical impossibility, however, of an exclusive race of women forever separated from the men, living more than a generation, renders it extremely doubtful that such a race ever existed, except in legendary lore. Accounts of them may be found scattered through the mythological tales of both Greece and Rome, but never in authentic history except as hearsay. The earliest historical record—that of Herodotus—is of this nature, and as it is a very pretty story it will bear quoting. Speaking of the different Scythian tribes, Herodotus says:

“Concerning the Sauromatæ, the following account is given: When the Grecians had fought with the Amazons (the Scythians call the Amazons *Aiorpata*, and this name in the Grecian language means manslayers, for they call *Aior* a man, and *Pata* to kill) the story goes, that the Greeks, having been victorious in the battle at the Thermodon, sailed away, taking with them in three ships as many Amazons as they had been able to take alive; but the Amazons attacking them out at sea cut the men to pieces. However, as they had no knowledge of navigation, nor any skill in the use of the rudder, sails or oars, when they had cut the men to pieces, they were carried by the waves and wind, and arrived at Cremni, on the lake Mæotis, but Cremni belongs to the territory of the free Scythians. Here the Amazons, landing from the vessels, marched to the inhabited parts and seized the first herd of horses they happened to fall in with, and, mounting on them, plundered the lands of the Scythians. The Scythians knew not what to make of the matter, for they were not acquainted either with their language, dress or nation, but wondered from whence they came. They conjectured that they were men of the same stature, they therefore gave them battle; but after the battle the Scythians got possession of the dead, and so discovered that they were women. On deliberation, therefore, they resolved on no account to kill them any more, but to send out to them the youngest of their own party, guessing a number equal to theirs; these were to encamp near them, and do the same as they did. Should the Amazons pursue them, they were not to fight, but fly; and when they halted were to come and encamp near them. The Scythians resolved on this, out of a desire to have children by these women. The young men, being despatched, did as they were ordered. When the Amazons found that they had not come to hurt them, they let them alone, and they drew one camp nearer to the other every day. The youths, as well as the Amazons, had nothing except their arms and horses, but obtained their subsistence in the same way as the Amazons did, by hunting and pillage.

\* \* \* \* \*  
\* \* \* \* \*

Afterwards, having joined their camps, they lived together, each having for his wife the person he first attached himself to. The men were not able to learn the language of the women, but the women soon attained that of the men. When, therefore, they understood one another, the men spoke to the Amazons as follows:

‘We have parents and possessions, let us then no longer lead this kind of life, but let us return to the bulk of our people and live with them; we will have you as our wives and no others.’

To this they answered:

‘We never could live with the women of your country, because we have not the same customs with them. We shoot with the bow, throw the javelin and ride on horseback, and have never learnt the employments of women. But your women do none of the things we have mentioned, but are engaged in women’s employments, remaining in their wagons, and do not go out to hunt, or anywhere else; we could not therefore consort with them. If, then, you desire to have us for your wives, and to prove yourselves honest men, go to your parents, claim your share of their property, then return, and let us live by ourselves.’

The youths yielded, and acted accordingly; but when they came back to the Amazons, having received what fell to their share of the possessions, the women spoke to them as follows:

‘Alarm and fear come upon us, when we consider that we must live in this country! In the first place, because we have deprived you of your parents, and, in the next, have committed great depredations in your territory. Since, therefore, you think us worthy to be your wives, do thus with us:—come, let us leave this country, and having crossed the river Tanais, let us settle there.’

The youths consented to this also. Accordingly, having crossed the Tanais, they advanced a journey of three days eastward from the Tannis, and three from the lake Mæotis northward, and having reached the country in which they are now settled, they took up their abode there. From that time the wives of the Sauromatæ retain their ancient mode of living, both going out on horseback to hunt with their husbands, and without their husbands, and joining in war and wearing the same dress as the men. The Sauromatæ use the Scythian language, speaking it corruptly from the first, since the Amazons never learned it correctly. Their rules respecting marriage are thus settled: No virgin is permitted to marry until she has killed an enemy; some of them therefore die of old age without being married, not being able to satisfy the law.”

Through such an account as this we can understand more fully the masculine nature of the warrior women in the scene upon our vase. In the mythological heroics we find them conquered by both Héraclés and Théseus, and various legends are given of their political condition and customs, among which that of cutting off the right breast in order to allow greater freedom in drawing the bow, was an invention of the Greeks, based upon the name of Amazon.

Concluding the consideration of the antique Roman work, we illustrate in figure 15 a shallow plate of silver having a low foot and chased in low relief with a hunting scene. It has a diameter of 11



Silver Plate, Figure 15.

inches. The intention of the artist in this scene is uncertain, but we may with confidence consider it as representative of some ancient myth and of none more probable than that of the Kalydonian hunt—a legend of great antiquity. In that case the two principal personages can be no others than Meleagros and Atalanté. The story of the Kalydonian hunt is repeatedly told in various forms upon the Grecian monuments, and the persons participating in that adventure were gradually augmented to include nearly all the national heroes, as the vanity of the different states of Greece prompted them in claiming for their especial celebrities the glory of every war and every expedition. Meleagros was the son of Æneus and Althæa. In offering sacrifices to the gods at the conclusion of the harvest, Æneus neglected Artemis (Diana), and that goddess, in revenge, sent a wild boar of immense size and strength to ravage the lands of Kalydon. It was to relieve the country of this pest that Meleagros invited all the heroes of Greece, including Atalanté, with whom he was in love. Atalanté was the daughter of Iasion and Klymene. Her father was very desirous of male offspring, and when she was born his chagrin was so great that he exposed her upon the mountains. There she was suckled by a bear, and afterwards found by some hunters who



named and reared her. She grew up very beautiful, very courageous, and passionately fond of the chase. Being afterwards recognized by her parents, her father wished her to marry, and she consented, on condition that her suitors should first race with her in the following manner: The suitor was to have the odds, and if she overtook him she was to kill him, but if not, then he should be rewarded with her hand. Many suitors had been sacrificed before Meilanión obtained from Aphrodité three golden apples and offered himself for the contest. In the trial Meilanión threw the apples on the ground as he ran, and Atalanté, stopping to gather them, lost the race. All this, however, must have been subsequent to the Kalydonian hunt.

At the hunt the hide of the boar was offered to whoever might kill him. Atalanté gave the first wound with an arrow, Amphiaraios shot him in the eye, and Meleagros, at last, ran him through the flanks and killed him, bestowing upon Atalanté the head and hide. Upon this the maternal uncles of Meleagros took the trophy from her, claiming that it fell to them if Meleagros resigned his claim to it, but Meleagros, enraged, killed them both, and restored the skin again to Atalanté. This action proved fatal to Meleagros, for it is stated that when he was seven days old the Moeræ (Fates) declared that when the billet which was burning upon the hearth should be consumed he would die. His mother snatched the stick from the flames and carefully preserved it. Now, however, giving away to resentment at the death of her brothers, she restored it again to the fire and, as it consumed, Meleagros wasted away and died. Repenting, when it was too late, Althæa put an end to her own life.

In the scene upon the plate we observe in the background a castle, strongly resembling the "Tower of the Winds" in Athens. The foreground holds two hunting dogs and a net; on the left is an assistant, represented as slightly bent over, as it was customary to picture the lower classes, and bringing in one of the victims of the chase; and in the center the principal figures with weapons and a horse. Beneath the plate there is an inscription of undeciphered Byzantine characters, which was stamped at some later date.

We turn now to a new field no less interesting and no less interwoven with historical reminiscences. Previous to the settlement of Greece, and contemporaneous with our earliest record of Egypt, there existed in the valley of the Euphrates and the Tigris a powerful nation claiming as their founder the mighty hunter Nimrod. The reïcs, which are constantly being uncovered by the spade in this territory, prove the magnificence of their cities and the strength of their arms. Their houses and palaces were embellished with a regal splendor compared with which all modern efforts sink into insignificance. The centuries of that period, so closely contiguous to the deluge, records for the inhabitants of south-western Asia those changes which perpetually signalize the history of man—the rise, the sovereignty and the overthrow of empires. The long line of Assyrian kings sat upon the conquered thrones of Chaldea, to be again succeeded by Median rulers, who, in turn, yielded to the more powerful and luxurious Babylonian monarchs. The accumulation of this extensive period of conquest and glory fell into the hands of the Persians and those great peoples and governments, which seem prehistoric, were absorbed into the greater and more powerful kingdom of Cyrus. One little state only repulsed the advancing hordes of Asiatics. Greece resisted successfully all attempts upon her freedom, and, eventually, proved the law that the tendency of empire is ever westward by subduing the orient. In 226 Artaxerxes Bebigan reclaimed the different Persian states and founded a dynasty that existed for 425 years, or until the invasion of the Mohammedans. This was the famous dynasty of the Sassanides.

If these brief historical facts appear out of place we must not forget that a magnificent original art requires for its foundation a magnificent people, and, even if art be not original, it must perforce embody some of the traditions of a past glory and exhale the fra-

grance of a brighter epoch. I have given it, however, more to recall the right of the Persians, under the Sassanide kings, to a rich legacy of past skill, and to locate the objects which are to be described. The discovery in a government of Russia so far north as Viatka, of a Sassanide plate of silver is an evidence of the existence of commercial relations extending over a wider territory than, in consideration of the early barbarism of Russia, might be expected. Yet such an object was found, and also others similar in the adjoining government of Perm. Of the first a copy is included in the collection we have been examining. The plate measures 10 inches in diameter, and the silver is of a very high standard. It is bordered with tressed work, and presents, in a center of burnished gold, the figure of a dragon, winged and bearded, and with a pendant tail. His paws are those of a griffin. Before his breast are stamped in relief two flower buds with the stems touching the circumference. The scales upon the body are indicated by dots or *pointille*. It was found by a peasant named Suzof, and was secured for the Russian government by M. Frontisky at the meagre price of 200 roubles (\$152.00). Its period is probably that of the 6th century of our era. With this we also notice a shallow bowl or plate of silver, partly gilt, which has a small circular foot, and appears to have been made of several pieces. Figure 16 is an illustration of it. The subject represents a hunter



Sassanide Silver Plate, Figure 16.

on horseback turning in his saddle, at full gallop, in the well-known manner of the Parthians, and directing an arrow at a lion, already wounded, who is reared upon his hind feet in a threatening posture. From the accoutrements and dress of both man and horse we may infer that the rider is intended for the Sassanide king. In the foreground is a boar, with an arrow in his side, entangled in a thicket. Below this is a conventional representation of water with two fishes and a goose.

The archeological value and interest which is attached to these Sassanide pieces is very great, but the arguments which prove them to be of Sassanide production are too extensive for review, even if the scope of this work permitted the digression. That the skillful artists of the East, from whom the Greeks derived the bulk of their knowledge regarding toreutic work, should have cast the shadow of their art over their descendants is not incredible, and from that shadow, faint though it be, we may gather some idea of that high excellence which, in earlier times, could teach the Greek.

(To be Continued.)

## The Jewelers' Security Alliance.

President, DAVID C. DODD, JR.

Vice-President, AUGUSTUS K. SLOAN.....Of Carter, Sloan & Co.  
 Treasurer, W. C. KIMBALL.....Of H. F. Barrows & Co.  
 Secretary, C. C. Champenois.....Of Champenois & Co.

## EXECUTIVE COMMITTEE.

C. G. ALFORD, *Chairman*.....Of C. G. Alford & Co.  
 C. B. BISHOP.....Of Carrow, Bishop & Co.  
 HENRY HAYES.....Of Wheeler, Parsons & Hayes.  
 J. B. BOWDEN.....Of J. B. Bowden & Co.  
 DAVID UNTERMAYER.....Of Keller & Untermeyer.  
 E. F. DORRANCE.....Of Dorrance & Brother.

P. O. Box 3277.

Room 2, 170 Broadway, New York.

HON. ALGERNON S. SULLIVAN, *Counsel*.

At a meeting of the Executive Committee of the Alliance held in November, on the 21st inst., and at a preceding special meeting, the following applicants were admitted to membership, viz.:

LeG. S. Strang, Amsterdam, N. Y.; E. H. Hohl, Mauch Chunk, Pa.; Jas. B. Hayden, Topeka, Kan.; John Marsh, Antwerp, N. Y.; Sandland, Capron & Co., No. Attleboro, Mass.; H. W. Graber, Brenham, Texas; H. J. Hallock, Wyalusing, Pa.; Ripley Howland Mfg. Co., New York City; H. C. Miller, Washington, N. J.; A. M. Fargeman, Fergus Falls, Minn.

## The History of Goldsmithing.

*Continued from page 327.*

THE CUSTOM of binding the Holy Books very sumptuously, and adorning their boards with ornaments of goldsmithing, gradually became more common. There are very ancient specimens of this kind extant. We have already mentioned the copy of the Gospels of Monza which dates from the eighth century. The Bibliothèque Nationale, of Paris, and the Louvre contain several other very beautiful specimens, several of which belong to the Carolingian period. A copy preserved in the Museum of the Louvre has, unhappily, been despoiled of one of its boards; the other is ornamented with a gold bas-relief, representing the angel and the holy women at the sepulchre of Christ. It is surrounded with a small border, and between two beaded lines are contained inscriptions in Greek letters, by which characteristics we are able to assert that it is of Byzantine origin. Another copy, still more interesting to us, because it is complete and of occidental workmanship, is known as the Bible of Charles the Bald. The manuscript is one of the most precious antique volumes which we possess, both by its own intrinsic worth and the beauty of its binding of goldsmith's work.

At the mention of the name Charles the Bald, we involuntarily remember the magnificent presents which he made to the church of St. Denis when he became its abbot, and among which figured in first line a gold triptych (which was afterward converted into an altar facing, enriched with so great a profusion of jewels that their simple enumeration occupied fourteen pages of the inventory of the abbey), next, a large reliquary, in the composition of which entered nineteen marks of gold and the weight of fourteen marks of precious stones; finally, the celebrated bacchic vase, still preserved in the Cabinet des Antiquities, Paris, by the name of the "Cup of the Ptolemies." The cup is antique, but its mounting is of Carolingian workmanship.

The abbey of St. Denis contained several workshops and a school where goldsmithing was taught—which shows the high esteem in which our art was held at that early age. The prelates and abbots of the monasteries rivaled in ostentation with the kings and princes. Among the former the bishops of Auxerre followed the precedents established by their predecessors. In the year 800, Bishop Aaron, who accompanied Charlemagne to Italy, raised above the main altar of his cathedral a ciborium of gold and silver in imitation of those he had seen in Rome. Alaguilelmus, who died in 828, presented to his church a large gold crucifix, had the altar surrounded with a railing

with silver bas-relief, and added to this ten large silver chandeliers and three crowns. After him, the Bishops Heribald and Vasa endowed their cathedral with a great number of holy vessels of gold and silver. Next, at Rheims, Archbishop Hincmar enclosed the relics of St. Remy in a shrine surrounded by twelve figures of bishops. At Angers, another bishop, the blessed Perpetuees, who died in 877, followed the example of St. Elias, and wrought with his own hand two shrines in the form of spirals or small churches, for enclosing relics. He is considered the first goldsmith who applied the process of casting in molds.

The abbots, on their part, were not to be outdone. While St. Denis overflowed with riches due to royal munificence, Angilbert, abbot of St. Riquier, the favorite of Charlemagne, undertook the reconstruction of his monastery, and decorated the holy place with an extreme sumptuousness. The altar was of rare marble with a facing of gold and silver, studded with jewels, and covered by a ciborium of the same precious materials, to which was suspended a crown and a gold cross. Six bronze columns, ornamented with gold and silver, formed a sort of lobby before the sanctuary, with a roof divided into seventeen arcades, between which were suspended silver vessels.

About the same time, Ansegises, abbot of St. Wandrille, enriched his abbey and that of Luxeuil with a number of holy vessels of a great value, among which must be mentioned a superb chalice ornamented with jewels, several silver chalices with figures in relief, and an altar facing of silver.

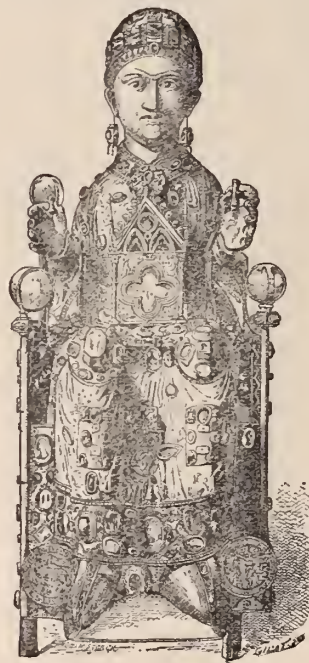

FIG. 21.

Begon, on his part, presented to the abbey of Conques, in Rouergue, numerous pieces of goldsmiths' work, a few of which, by strange fortune, have come down to us. M. Darcel attributes to him a gold statue of Sainte Foy, of the height of 34½ inches, which is certainly the most important part of the collection, as far as beauty of workmanship is concerned. Fig. 21 represents the statuette of the saint.

A long list of abbots and prelates, who contributed largely toward making goldsmithing one of the fine arts, might be given, but we forbear for fear of tiring the reader, and we close this chapter by mentioning the names of two Norman goldsmiths, by the name of Othon, one of which lived in the time of William the Conqueror and the other one in the next century. M. Labarte also gives the names of three French goldsmiths: Odulfus, monk of St. Riquier, Berhelinus and Bernuinus, canons of Sens; both are mentioned in the chronicles of this epoch.

## 2.—Italy and Germany from the Fifth to the Tenth Century.

Although since the withdrawal of Constantine, Rome had ceased to be the capital of the Empire, it still remained the seat of the Holy See, and was esteemed as the Holy City in the eyes of the Christian world.

To the vast riches, accumulated there by the emperors, began to be added those which, in the ardor of their new belief, were deposited at the feet of the successors of St. Peter by the princes recently converted to the Christian faith; and the popes, thus placed in possession of an immense wealth, speedily applied it for the benefit of the many churches that sprang up everywhere throughout the Eternal City. The goldsmith was called on to exert his imagination by devising designs for adorning these holy places, and fashion by his handicraft the holy vessels and emblems used in the various ramifications of religion.

Rome had not lost its artists, although the goldsmiths of the Oriental Empire proved to be dangerous rivals, and when, in 357, Constance took a fancy to visit the city abandoned by his father, the Romans caused him to make his entry into the city in a chariot overlaid with gold and glittering with jewels; about twenty years afterward, the Greek Emperor, Gratian, made the same tour with his wife, and, in commemoration of the event, the Romans erected statues of silver in their honor.

Rome, however, lavished the principal bulk of its treasures for the glory of the God of the Christians and the patron saints of the church.

In the fifth century, Pope St. Celestine presented a service of holy vessels, of goldsmiths' work, to the basilica of St. Julius, which he had erected; his successor, St. Sixtus, raised a statue to St. Laurentius, also a *bas-relief* of gold, of Our Lord Jesus Christ and His twelve apostles; soon after them, Saints Hilarius and Symmachus in the same manner enriched their churches with gifts of goldsmiths' work, the list of which has been preserved to us in the *Liber pontificatus*.

What remains of all this immense wealth? Alas, nothing, or almost nothing. Beside a few vases and a small chased silver trunk, pertaining to this epoch, and preserved in the Christian Museum of the Vatican, we actually possess nothing.

From the fifth to the eighth century Italy was so often pillaged, ravaged and sacked by the barbarians, who envied each other the possession of this beautiful country, that it is rather a marvel that anything wrought before their conquests should have had the good fortune to escape. A few of these barbarians were Christians, however, and while they pillaged the country with one hand, they donated new riches to the churches with the other. To this number pertained Theodorick, the king of the Goths, and several Lombard princes. On the other hand, many others were most justly entitled to the cognomen of the "Scourge of God," for instance, Attila, Genserich, the Huns, Vandals, Saracens, these merciless pagans who knew that they could not establish a dynasty that would last any length of time, and therefore mercilessly devastated, killed and burned whatever they could not carry off.

Vainly, during these dark centuries of misfortune, did several of the Roman Pontiffs essay to decorate their churches with works of art, none the less precious in workmanship than in material. Gregory the Great, at the end of the sixth century, caused a ciborium of silver to be raised above the large altar of St. Peter, and St. Serge, in the following century, erected a statue of gold to this saint; but these works simply proved to be a bait to attract the ruthless invaders.

The end of the eighth century, however, finally brought to unhappy Italy a period of rest—gladly would we have written of peace—but, alas, such a condition was unknown at that time, and art and science gradually began to revive. The name of Charlemagne caused the barbarians to retire in hot haste, and under his powerful protection the Church again began to be the promoter of arts and artistic productions.

The first care of the Popes was to hurriedly repair the churches, which had been repeatedly pillaged and wantonly destroyed during the last two or three centuries. From the middle of the century forward, Gregory III. devoted large sums to goldsmithing of sacred objects. His efforts, however, were completely eclipsed by the numberless presents to the churches of Rome by the Popes Adrian and Leo III., contemporaries of Charlemagne, the former dying in 795 and the latter in 816. Adrian used for the holy vessels and in the decoration of the church of St. Peter, five hundred and ninety-seven pounds of gold and one hundred and thirty-six pounds of silver, and the metallic value of the pieces of goldsmiths' work which Leo III. donated to the churches during his pontificate, footed up to a sum total of one thousand and seventy-five pounds of gold and twenty-four thousand seven hundred and forty pounds of silver. Anastasius the Bibliothecary, has left us the details of all this goldsmiths' work, in

which are mentioned forty-two statues of gold, one hundred and thirty chalices and fifteen gold crosses, forty-seven lamps of the same material, etc. It is true that Leo III., who was pontiff during the time of Charlemagne's greatest power, was cunning enough to secure the lion's share of the many gifts which this great emperor loved to make to religious institutions.

His two immediate successors, Stephen IV. and Pascal I., were also lovers of ostentation and pomp. Stephen, when he went to France to crown Louis le Débonnaire, carried with him from Italy a gold crown sparkling with jewels. Unhappily, he died the next year. Pascal I., who lived to enjoy a longer pontificate, caused many handsome pieces of goldsmiths' work to be made, and especially did he have covered with ciborium the principal altars of a number of churches.

If, however, the ninth century, and more especially its first half, had been a flourishing period for the arts both in Italy and France, the following century saw this prosperity decline with the decay of the might of the Carolingian race.

New invaders, the Saracens, had overrun Italy and carried ruin and pillage into the very walls of Rome. All its industries were paralyzed, goldsmithing, perhaps, more so than the others, and only one pope, Sergius III., attempted to worthily decorate again the despoiled walls of the churches of the Eternal City.

But Rome is not Italy. Even while the city staggers under this renewed load of misfortune, the cathedrals and abbeys of all those portions of the country not visited by the invaders, and which think that they can safely escape being plundered, decorate their churches out of daring. From the eighth to the tenth century, the celebrated abbey of Monte Cassino caused to have made a great many pieces of goldsmiths' work, chiefly under the administrations of the abbots Gisulphus (who died in 797), John (who died in 915), and Alegiran (who died in 945). Fortunatus, the patriarch of Grado (who died in 824), follows this example, and the Doge Orseolo ordains the construction of the great altar piece of St. Mark of Venice, known by the name of *Palu d'oro*, which is an incomparable specimen of goldsmith workmanship and left for future generations to finish.

It is true, however, that this *palu d'oro*, at least its more ancient portions, cannot be considered as a product of Italian industry; it is established beyond a doubt that Orseolo ordered its construction of Byzantine goldsmiths. Indeed, it bears all the characteristics of Byzantine workmanship of that age—so rich and delicate in tracery, so complete in all its minute details and exquisite *cloisonné* enamel.

Another altar piece of goldsmiths' work of the same kind, to be seen in the church of Torcello, was also the work of Byzantine artists.

The intimate commercial relations existing between Venice and the Empire of the Orient sufficiently explains the reason why the Venetians made use of the well known talent of the goldsmiths of Constantinople.

On the other hand, the heresy of the iconoclastes and the proscription of the worship of images, had driven a large number of Greek workmen out of the country into Italy, who, little by little, introduced new styles and new methods. Italy had always possessed its share of artists, but to judge by the speed with which they adopted the Greek methods, we are led to think that they must have considered them to be superior to their own.

In support of this hypothesis, we may cite the admirable facing of the altar of St. Ambrosius, at Milan, known by the name of *paliotto*. The erection of this piece of goldsmithing, one of the oldest, richest and handsomest in the world, dates to the year 850.

The names, both of the person who ordered and the artist who executed it, are known to us. The founder was Angilbert, Archbishop of Milan. The artist, whose name, as well as that of Angilbert, is inscribed upon one of the panels of the *paliotto*, was Volvinus—a name whose very sound is not Greek; and although the appearance of the *paliotto* inclines to the Greek style, as do also its enamellings, still, when we examine it closer we will perceive it to be

a corrupt Roman style, by the attitude of the figures, their habiliment, style of drapery, etc.

The number and minuteness of the details which enter into the composition of the *paliotto* of Milan, render it almost impossible to reproduce it in a satisfactory manner for the columns of THE JEWELERS' CIRCULAR, and we must content ourselves with singling out one medallion (and, as we believe, the most interesting one), in which the goldsmith represents himself at the feet of St. Ambrosius. The reader will see at the same time how the borders, which serve as frames to the medallions, are arranged alternately with bezels of enamels and precious stones. Pearls are also employed in profusion in the borders. The figures are chased; those of the anterior face upon sheets of gold, the others upon gilt sheets of silver.

Upon the anterior face we behold, in an almond-shaped border, the figure of Our Lord seated on his celestial throne in the center of a large cross, each of whose branches carries the attributes of one of the four evangelists. Between the branches of the cross are disposed in groups of three, the figures of the twelve apostles. On the two sides of this central part are represented in twelve square tablets (six on each side), the principal events of the life and passion of the Saviour.

The posterior face, as rich as the other, if not by reason of the material, at least by the beauty of its decoration, possesses to us a still greater interest. Twelve square tablets, arranged similar to those of the anterior face, represent incidents from the life of St.

Ambrosius. The central portion, formed of two shutters which open on hinges, is composed of four circular medallions. The upper ones represent the Archangel St. Michael and the Angel Gabriel; in one of the lower ones, Volvius has portrayed himself kneeling at the feet of St. Ambrosius, while the other one portrays the Archbishop Angilbert in the same attitude.



FIG. 22.

The narrow sides of the *paliotto*, those which cover the two ends of the altar, are almost square. Within this square is traced a large lozenge, from the center of which is raised a large cross, sown over with an infinite number of pearls and precious stones. The empty spaces left between the cross and the border of the lozenge inclose figures to the number of eight at each end, of saints most honored in Milan. Finally, eight other figures fill out the angles between the border of the lozenge and the altar piece itself. They are figures of angels carrying suitable attributes.

The richness and exquisiteness of the borders of the frames around the different groups and around the medallions, contribute to make the *paliotto*, perhaps, the rarest piece of workmanship of the early age. Gold, precious stones, pearls and emeralds are employed with such a profusion and harmony that the eye is, at the same time, dazzled and charmed.

To sum up; we do not hesitate to assert that the *paliotto* is the most admirable specimen extant of Christian goldsmithing anterior to the year 1,000.

Germany, however, also possessed its goldsmiths in all times, even the most remote. Tacitus himself speaks of vases of silver which the ancient Germans offered as presents to princes and ambassadors. Although little is known of their productions.

Concerning the goldsmithing of the Germans of the early age, the most ancient specimen known is a chalice from the time of Tassilo, Duke of Bavaria, whose name it bears. Tassilo lived in the eighth century.

In the last years of the next century, Emperor Arnulf, or Arnul-

phus, made very rich presents of goldsmithing to the church of St. Coneran at Ratisbon (Germ. REGENSBURG), and had plated with gold the main altar of this church; he also caused it to be covered with a ciborium which was supported upon eight columns.

It appears that the industry of goldsmithing was cultivated at a very remote period in certain abbeys of the Empire of Germany, chiefly at St. Gall, this celebrated monastery, the sanctuary of science as well as of piety, which still contains a library justly renowned for its rare and admirable manuscripts. Both arts and letters in it found their number of adherents, and many of its monks were goldsmiths. The most ancient one mentioned in its chronicles is Genrich, who lived in 823. At the end of the same and the beginning of the next century, we find another monk of the same community by the name of Tutilo, who wrought for the Abbot Salomon a large cross and an altar (which means the facing of an altar) of gold, set with precious stones. Later, in the tenth century, the altar received another gold facing by the Abbot Imsicon, who appears to have constructed it with his own hands.

The example of St. Gall found imitators. To mention only one instance: toward the end of the tenth century, the Abbot Wittego, or Witigo, of Reichenau near Constance, donated an altar facing to the church of this celebrated monastery.

It is a remarkable fact that only from this century forward do we find any mention in contemporaneous descriptions of goldsmithing of German origin, of the human figure being employed in their designs. To judge from contemporaneous writings and a few specimens descended to us, we are led to conclude that the Germans produced only mediocre work, and as a body were much inferior to French and Italian workmen.

Nor does goldsmithing at this period appear to have been farther advanced in England. We find that in the abbey Ely, an abbot by the name of Brithnodus caused to have made, toward the end of the tenth century, four statues of the Virgin of silver, and enriched with jewels. But a contemporaneous witness says that these statues were of wood, and simply overlaid with sheets of silver.

Thus we see that the art of goldsmithing in Europe was, at this period, still in the cradle, and in common with the greater number of the various other arts, it was to develop only after the dreaded period of the year 1,000 was passed.

(To be Continued.)

## Lathes and Lathe Work.

BY THE MODEL WATCHMAKER.

TO MAKE our lathe centers we should get a piece of round steel  $\frac{3}{4}$  of an inch in diameter and 5 inches long. This piece of steel should be annealed by putting into a charcoal box and heating. The manner of annealing in an iron box has been described, but for those who have not the back numbers of this journal I would say, for such a lathe one should have about 3 sizes of iron boxes made of heavy iron tubing. The largest about 3 inches in diameter and 10 inches long; the next smaller, 2 inches in diameter and 14 inches long; the smallest 1 inch in diameter and 6 inches long. One end of these are to be welded shut with a wrought iron plug, and the other with a loose-fitting plug. Such an annealing tube or box is shown in fig. 1, which shows a longitudinal section; *b b* representing the tube, *a* the loose plug, *d* the welded, in plug, and *c* the piece to be annealed. The space *e e* is filled in with fine charcoal. Such a box has the piece packed with fine charcoal as shown, and the top plug *a* plastered in with clay or whiting made into a thick paste. The box should be put in a coal fire—a wood fire will do—and heated evenly until red hot, at which temperature it should be maintained for an hour, when the box should be buried in hot ashes and left to cool off, which will take 12 hours if one of the larger boxes are used. Our piece of steel should be filed to a conical point at

each end as shown at fig. 2. The points  $f f$  should be as near round and conical as possible without taking too much care. We must now provide a hand rest for our lathe. The principal part of this is made of cast iron and shaped as shown in diagrams  $A^*$  and  $B^*$ , and consists of a flat part  $A$ ,  $2 \times 6$  inches and  $\frac{1}{2}$  an inch thick, with a cylindrical piece projecting upward to hold the tool rest. The piece  $B$  extends under the ways and the bolt  $C$  serves to clamp it in any position. In turning our centers we need no slide rest, but we need a temporary center in one of the heads. This will need only a countersink in the end for one of the conical points  $f$  to run into. It is essential, however, that this temporary center should be firm in the head. To secure this steadiness we will take a piece of round iron (or a short piece of the steel rod we bored out our heads with) half an inch in diameter and  $1\frac{1}{2}$  inches long; shape it as shown in diagram  $D^*$ . To explain the manner of doing this we will refer to diagram  $D^*$ , which is a transverse (horizontal) section of the head  $F$ , fig. 3, parallel to the ways  $E$ . This diagram is enlarged to show the parts. We flatten both sides of  $D$  for  $\frac{7}{8}$  of an inch as shown at  $j$ ; this flattening is to the depth of  $\frac{1}{8}$  of an inch on each side as shown. Now, if we make a washer shaped as shown in diagram  $D^{**}$

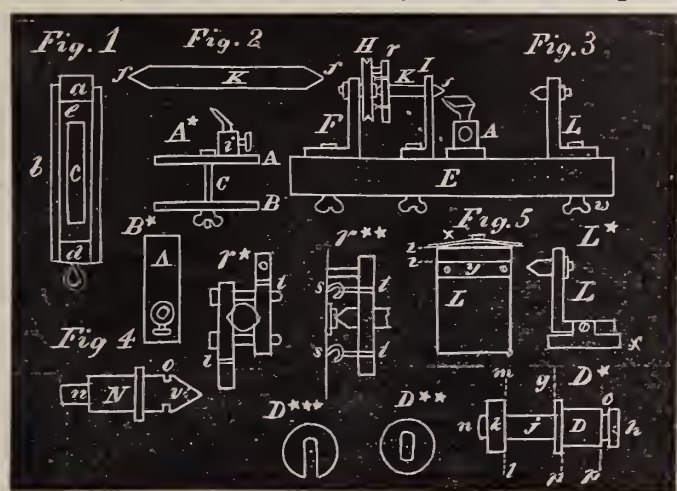

it will slip on  $D$  until the inner face is on the line  $g$ . The lines  $g$  and  $m$  represent the inner and outer surfaces of the head  $F$ . If, now, we round up the part of  $D$ , from  $l$  to  $n$ , to  $\frac{1}{4}$  of an inch and cut a screw on it, we can, by means of the nut  $k$ , draw the center  $D$  firm against the head  $F$ . One more addition to  $D$  and we have it complete; this addition consists in filing two notches in  $D$ , as shown at  $o o$ , in which we can slide a washer cut open on one side as shown at diagram  $D^{***}$ . The loose pulley  $H$ , fig. 3, will occupy the space between the dotted lines  $p p$ , diagram  $D^*$ . At  $h$  is drilled a countersink for one of the points  $f$  to go into. The loose pulley  $H$  has a hole in which the pin from the dog  $r$  enters. The peculiarity of the manner in which the work is held in the lathe and pressed against the center  $D$  is by having the dog  $r$  made as shown at diagram  $r^*$ , which is a view seen in the direction of the axis of the lathe, and diagram  $r^{**}$  is as if seen at right angles to the lathe axis. The dotted line in this diagram represents the side of the pulley  $H$ , and the hooks  $s s$  are inserted in the pulley and serve, by means of the elastic bands shown at  $t t$ , to hold the piece  $K$ , fig. 2, pressed into the center  $D$ . We insert the piece  $K$ , fig. 2, in the lathe as shown in fig. 3. Now, one end of  $K$  is inserted into the countersink of  $D$ , and the other just extends through the back rest  $I$ . It is easy now (motion being given to the loose pulley  $H$  by countershaft and foot wheel described in last communication) to turn the point  $f$ , extending through the back rest, to a nice conical point if the piece  $K$  is round. A word or two on getting a piece of round steel for these centers: round steel can generally be obtained up to one inch in diameter almost as round and true as if turned up in a lathe. If such can be got it is best to use it; if no larger than  $\frac{5}{8}$  is to be had it will answer. If the ordinary round steel can only be obtained, point it up as at  $f f$ , so as to have the piece ( $K$ ) run as near true as possible, and without any back rest put it between the two centers,

turn about  $\frac{1}{2}$  an inch of each end true and round. Now, by means of the back rest, working alternately on these trued-up places, turn up the cones into perfect form. Then again put the piece  $K$  between the double centers and proceed to turn with your hand tools until each end is as shown in fig. 4. The reason for changing about with the piece of ordinary round steel, is because the common kinds of round steel is not true enough to get good results with the back rest in turning up the cones. While the temporary points  $f f$  are sufficiently accurate to turn a piece on each end which will enable us with the back rest to turn nearly perfect cones. Fig. 4 only shows one center, the other is supposed to be severed at  $n$ ; the part at  $u$  being  $\frac{1}{4}$  of an inch in diameter and cut into a screw and provided with a nut as shown at  $k$ , diagram  $D^*$ . The part shown at  $N$  is not flattened as in the former center. It is well to have two sets of centers, one set as shown at fig. 4, and another set with hollow cones as indicated at the dotted outline at  $v$ . It is often convenient to use such hollow cone centers for pointed bits of wire one desires to turn. Clock-makers almost universally use pointed ends to their arbors and pinions. In many of the operations of turning, the use of a weight to steady the part (a slide rest, for instance), is better than to depend on the rigidity of the parts. It has undoubtedly suggested itself to the reader that such a lathe would be a little difficult to manage about taking up wear and end shake in a piece we were turning—to illustrate, suppose we have a rod in between the two centers, and the countersinks wear a little so that end shake exists. Now, in a lathe of the ordinary construction, it would be very easy to advance the back center, as this usually is forced forward with a screw. In the present case we have to move up one of the heads with its center. This can be done quite easy by loosening up one of the clamping screws—say at  $w$ , fig. 3—and pushing the head firmly against job to be turned, keeping the guide (which has been described in a former article) pressed against the ways. Another method by which this motion would be facilitated is by putting a spring on the back of the head (say  $L$ , fig. 3). At fig. 5 is shown the bottom of  $L$ , fig. 3, seen from below; here  $y$  represents the guide piece secured to  $L$ , and  $x$  the spring. The position of the way (the back one) is indicated by the dotted lines  $z z$ . Diagram  $L^*$  is a rear view of  $L$  seen from back of the ways, and shows the form of the spring  $x$ .

## Problems in the Detached Lever Escapement.

BY DETENT.

IN WRITING these articles the writer has tried to make them thoroughly practical in every sense, and now he proposes to give the actual use of the knowledge we should have gained. He would advise changing the working model to a club tooth (it needs only the scape wheel and pallets changed—the fork and roller actions are all right), and study the principles involved, moving the adjustable pallets about so as to get effects. Still I would warn the reader that the study is more obscure than in the ratchet tooth, because part of the power is derived from the pallets and part from the impulse face of the tooth. But one golden maxim will help the reader if he takes it as the basis of his study, to solve by patient thought and analysis most of the troubles he will have to overcome, it is this: *In a good sound lever escapement the tooth engaged should leave the locking face a little before the fork has advanced one-fourth of the way to the opposite bankings, but the tooth should not drop from or leave the impulse face until the fork almost (but not quite) touches the opposite banking. And the tooth just released should not drop or fall but a slight distance (2 or 2½ degrees).* If these conditions are strictly fulfilled there is but little—indeed nothing—can be done to improve the pallet action. If your watch does not have a good motion and your escapement in the condition described, look over the fork and roller, and if these are also all right the trouble is in the train. But with faults of depth and proportion of wheel to pinion the writer does not propose, at the

present, to meddle. I do not think I can do better to instruct the student than to give a portion of a letter from a young watchmaker to whom the writer had given (not regular) but occasional instructions. He writes: "I have a fair Swiss lever, full jeweled, and a tolerably well finished train; it has a short, straight line lever which seems to be of the proper length to suit the roller. The angles to the pallets seem to be all right, both impulse and locking, *but the teeth seem to drop away up the pallets*, yet there is no *slide* when the tooth escapes as the fork is over against the bank. I can take hold of the center wheel when the balance is out and reverse the power, and the fork and pallets will buzz backwards like fun. Yet when you take hold of the fork to unlock the escapement you'll have to move the fork half way over before it will unlock. Now, what am I to do with the thing? is the escapement too deep? if so, should I take off the pallets and file the holes and set them back—this would not do, I would still have the same slide. If I close the banks the fork is too long, and if I file off the guard for bank shake the jewel pin won't leave the fork, and if I file out the fork to free the jewel the thing won't go at all, *eh?* Now, please tell me what the trouble is, for the thing has next to no motion and *stops*." Here ends our young friend's letter, and he is in precisely the same fix that lots of my readers may or have been in. Now, if he had applied the rule given in italics above he would have found the *clue* if not the *key* to the mystery in the fact that the escapement did not unlock before the lever had passed one-fourth of the way over to the opposite bank. As he writes "when you take hold of the fork to unlock the escapement you must move it (the fork) half way over before it will unlock." Let us consider the situation; suppose we make a pair of pallets shaped as shown in fig. 1, *i. e.*, pallets with all locking face and no

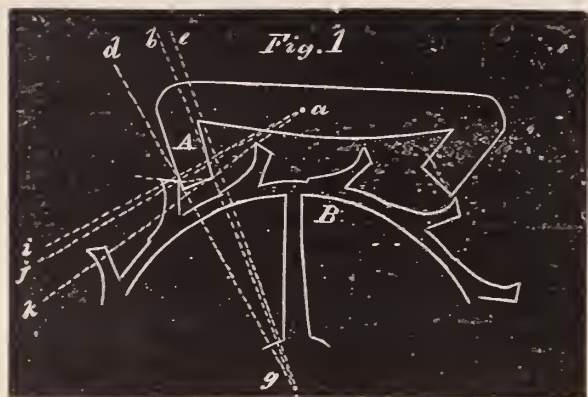

impulse, so that when the fork is moved over the tooth merely slides over the impulse face without imparting any accelerating influence to the pallets. Or they can be shaped so as to impart only a slight or indifferent impulse to the pallets. Now, this was precisely the case with the escapement the young man had in hand; the pallets had too much lock and not enough impulse. As this is a very common fault in Swiss anchor escapements we will give the subject careful attention. In a case of this kind we should proceed as follows: While the balance is still in put a light spring under the balance so as to hold it in any position; (I should have said, perhaps, try the balance for side shake to the pivots), and then put the tinsel or paper friction under the balance to hold it in any position—turn the balance so the jewel pin is well out of the fork, and with a fine, delicate pointed pair of tweezers test the bank shake, *i. e.*, see if the fork will make about  $\frac{1}{2}$  of its vibration before the guard point will strike the roller—do this on each side. Now, take out the balance for we have established the fact that our bank shake is all right; try the fork to see how far it has to be moved before the unlocking takes place. We see, as described in the extract from our friend's letter, that the fork passes nearly or quite half way to the opposite bank before the pallet engaged is unlocked. We next examine and see that the tooth falls after leaving the engaged pallet but about the right distance ( $1\frac{1}{2}^\circ$ ) before it is arrested by the next pallet. By this course we determine whether the pallet arm is deep enough; by this I mean we should ascertain whether even if the

impulse face should be of the correct form it would hold the tooth to its work until the desired amount of impulse is imparted to the pallet. This part of the subject is a little difficult to get the correct insight into, because some escapement makers divide the impulse up about equally between the pallet and the tooth, while some give the pallet the greatest amount of impulse. If the impulse is about equally divided the pallet *looks* thin; still, it will do its work. But if we apply the italicised rule above we shall be all right in either case. In fig. 1 at the dotted lines  $g d$ ,  $g b$  and  $g e$ , we are shown the correct angular motion of the scape wheel. At every escape or tick the scape wheel should pass through  $12^\circ$ , that is, from  $d$  to  $e$ , and the arc of motion from  $d$  to  $b$ ,  $10\frac{1}{2}^\circ$ , should be utilized as impulse, while  $1\frac{1}{2}^\circ$  from  $b$  to  $e$  is lost in so-called drop. Practically it makes but little difference how the  $10\frac{1}{2}^\circ$  are utilized, *i. e.*, whether  $7^\circ$  of impulse is derived from the pallets and  $3\frac{1}{2}^\circ$  from the tooth, or whether the impulse is equally divided between the tooth and the pallet. What to be looked after is the *drop* and see the tooth does not have to fall too far after it has ceased to act—as all this is lost. The eye will soon learn to judge if more than the necessary  $1\frac{1}{2}^\circ$  is lost in this way. It is probable that one pallet will have too much drop and the other be nearly or quite right. How to treat such inaccuracies will be described subsequently. But in regard to the error under consideration we will have to grind off our pallets so the impulse face will be capable of imparting its power to the balance. We shall have to defer the manner of proceeding of how to cut away the angle until our next; but the writer earnestly desires the pupil to study the problem considered in this communication. To make a sort of recapitulation: The arc embraced by the dotted lines (from the center of the scape wheel  $B$ ) at  $d b$ , represent the advance of the scape wheel, and all this advance should be utilized to propel the balance through the fork, and only the  $1\frac{1}{2}$  degrees between  $b c$  lost in drop. Of the pallet action its arc of motion is shown at dotted lines  $i j k$ , and all the 8 degrees between  $j$  and  $k$  should also be utilized; the arc between  $i$  and  $j$  represents the lock in this arc no power is lost except by friction as the scape wheel does not advance. The result to be accomplished is to utilize *all* the power for the balance which can be got from the angular motion of the scape wheel in its arc  $d b$ , through the pallets in their angular motion from  $j$  to  $k$ . This problem may seem a little dry and prosy, but I assure the reader that let him master it and acquire the technical skill to make the corrections, and he will laugh at any troubles the club tooth escapement may present to him.

### The Regulating of Watches.

[By HERMANN GROSCH, in his *Praktisches Handbuch für Uhrmacher*.]

*Continued from page 318.*

IF A WATCH loses in heat, move the turning screws or weights near the end of the rim closer to the notch, and if this change produces no satisfactory result, then replace the last pair of timing screws standing opposite to each other with platinum screws. This remedy is but seldom necessary, however, with the length of the balance spring at present employed. The proper way to do it is easily acquired by practice.

For adjusting in heat, the watchmaker requires a sheet-iron box, which is heated from below by an alcohol or gas flame and provided with several shelves inside, in which a thermometer, together with the watches, are located. The trials can be prosecuted from 95 to 112 and up to 22 degrees F., lasting each time for twelve hours.

For adjusting in cold in summer, he requires an ice box, the sides of which are stuffed with a non-conducting material; this box contains a strong sheet-zinc box which is filled with equal parts of cooking salt and ice; this, again, encloses another one, in which the watches to be tested, as well as a thermometer, are placed. Each of these tests is also continued for 12 hours at a time. More compli-

cated processes are necessary for producing lower degrees of cold. A very intense degree is produced by 10 parts ice, 4 parts salt, and of each 2 parts sal ammoniac and saltpeter. Timing below zero is but seldom resorted to.

Many a colleague of mine will have cracked his sly joke at my expense when he saw me put watches into the hot box; others have thought that the adjusting of the compensation was something very difficult—far more so than it really is; because, if we rightly consider the matter, we will see that no extra great amount of skill is required to shift a screw from one place to another. Care, of course, is necessary; such a balance wants to be handled gently. There is a certain kind of balances which are called compensated only by courtesy and are cut open, but an angel from heaven, even, would fail to obtain compensation and isochronism with them. In place of these wretched attempts, the Swiss manufacturers would do better to mount a simple steel or brass balance, and if they cannot leave such tomfoolery alone, they might at least desist from cutting such balances open. The sins of this nature committed in Switzerland surpasses all limits.

We finally arrive at the balance spring. There is not the least doubt that isochronism is with far greater difficulty obtained with a short balance spring than with a long one; the latter kind, if too long, are more dangerous for watches, because in consequence of the jars and blows to which they are exposed, they are apt to tangle and catch in the center wheel and regulator; beside this, an unduly long balance spring is too sensitive to concussions which injure the adjustment. Practice has established that 15 coils are suited best for an over-coil spring, the diameter of which may be equal to the radius of the balance. With this size it also becomes possible to use a nice, well hardened spring; it is a somewhat remarkable fact that I have generally found shorter springs not to be as well hardened as longer ones; I suppose that this may be due to a greater difficulty in their manufacture. Use them as broad as possible; they can be more easily manipulated, give better results and are more uniform in their performance than narrow springs, without being liable to cockle as the latter do.

The ear, even, will tell you how the spring performs; almost no sound is audible with a good, steady action, while the flat springs developing with irregularity, produce a peculiar hizzing, singing noise, easily recognized by experience, and which forebodes difficulties in adjusting. It may also be owing to an inequality in the thickness of the spring blade, single coils may be stronger or weaker than others; observe, therefore, the motions of the single coils attentively; such an inequality in the coils betrays itself by a peculiar trembling at the strongest and weakest places. Nothing can be done with such a spring, and it is best to throw it aside and take a new one.

An over-coil spring, in order to be called good, must not tremble, and when it has fifteen coils the eighth must appear to stand still. This is, perhaps, contrary to the opinion of many watchmakers, who demand a perfectly equable development throughout the entire length of the spring. The case is entirely different with a helical spring; a perfectly uniform development of all the coils of the spring must take place here, and this does really occur with every helical spring that was rendered isochronous, that is, by a proper bending of the terminal curves—a regular concentric increase or decrease in the size of the coils occurs with each vibration of the balance. Not so, however, with a flat over-coil spring; it is actuated throughout its whole length; but the first coil, lying nearest to the collet, is acted on far more than the second; this, again, moves more than the third, and so forth up to the eighth which, apparently, remains stationary, while again, the ninth coil moves, but less so than the tenth and so forth up to the fifteenth, which makes more of a motion than the fourteenth. Since at the moment of the greatest tension, when the motion of the balance has arrived at its extreme point, the eighth coil appears to stand still while the seventh and ninth move; it almost appears as if these two had approached to the eighth; this

appearance is repeated at every vibration, and is a good omen that isochronism is easily established with such a spring.

When a balance spring has not been put in yet, and it is necessary to make the terminal curves, I would advise to use for this purpose either strong steel pliers fastened in wood and which can be heated, or strong brass pliers; by the use of the latter there is less danger to injure the spring. Never bend much at a time, so that you do not overdo it, and are forced to bend back again; it is the same here as with bent pivots; if the steel was well annealed it is possible to again straighten a pivot that was not bent too much; but if you exceed the measure and are forced to bend back again, the consequence will be, in nine cases out of ten, that the pivot will break.

The knee is to be bent at a good distance from the place of fastening. I would recommend a gentle, gradual passing over into the upper coil, in place of the sharp knee so often found in Swiss watches; such an abrupt bending causes a greater or smaller disturbance in the molecular arrangement, especially with well hardened springs, which will have an injurious influence upon its capacity for adjustment. The portion of the spring bent up and again brought into parallelism with the lower flat part, is bent into a flat curve, which, when it has toward the center arrived upon the circle of the place of fastening, passes into a circle which coincides with the outer place of fastening in the stud and curb pins; this coil must be placed so that the regulator can be moved to and fro without the pins causing a displacement or a pressure upon one of its parts.

This circular bending is best performed with strong pliers specially adapted for this manipulation; one of its noses must be hollow, the other round and provided with wooden lining, between which the outermost coil of the spring, when it has been layered approximately, is pressed and heated. The rounding of the pliers must be somewhat smaller than required for the balance spring, because the latter always possesses a certain unconquerable elasticity.

The distance of the curb pins from each must not, under any consideration, be greater than twice the thickness of the spring blade. The center of the spring must exactly coincide with the center of the jewel hole.

The inner coil of the balance spring, around the collet, must be at a sufficient distance from the latter, so that there is no danger that it will either touch this or the place of fastening in the folding of the spring. This scraping, which betrays itself by a jerking similar to the cracking of a whip, would cause an acceleration of the large vibrations.

The kind of fastening is not by any means unimportant. If it were possible to make the fastening upon the collet vertical to the center it would be best, according to my opinion; this cannot be done, however, and we must follow the handed-down custom, but try to make the bend of this inner knee not round but as sharp on angles as possible—which must be done with hot pliers, and at once lay the first coil at the proper distance from the collet.

The ends of the balance spring are to be fastened with pins of hardened steel, whose sides, turned to the spring, are provided with flat faces; they possess the advantage that they can be taken out or inserted more conveniently.

Adjusting may be commenced next; the watch is permitted to go for 12 or 24 hours in one position, and we will suppose it to be the vertical; we note down the performance; it is next allowed to go for the same length of time in the horizontal position; we find that it has gained and note down its performance; and, lo, we are brought face to face with the mystery of isochronism. An adjuster who does nothing else than time watches and has a large supply of balance springs on hand, will not hesitate long in taking another spring, keeping the arc just taken down for another watch. We will try, however, to obtain our purpose with the spring in place.

First, draw through the piece still protruding through the stud so as to lengthen the spring; make the curve a little flatter or longer and compare again as before. If no improvement has been effected

by this manipulation we reverse the order, that is, we push the spring through a little more, of course beyond the first place of fastening, and shorten the curve. We then examine again.

An improvement will generally be produced by one of these manipulations, principally, however, by the change of the outer end curve. Should, in spite of this, a balance spring prove to be very obstinate, a last remedy may be employed by breaking a piece from the inner end and fastening the spring anew; it is necessary, therefore, when putting in a spring, not to leave the inner space empty so that use may be made of this last remedy; if it should become necessary when adjusting. When forced to employ this remedy break off only a little at a time.

It is quite an important matter in what angle the two places of fastening stand to each other; it is of advantage to let the inner fall in the center line of the outer curve, or to have the place of fastening at right angles to each other, although no fixed rules can for this be established, as all the other details of the watch, which are different with every one, are also to be taken into account, and the place most suitable has to be ascertained by experiments. Adjusting is a very difficult, vexatious and tedious art, and as much as \$30 are paid in Geneva for adjusting a first-class anchor movement in all positions and temperatures.

As far as my experience goes, isochronism can generally be obtained by treating balance springs in two different ways, viz., by altering the places of fastening and by flattening or rounding the curves.

In one case I was successful in obtaining isochronism by bending a serpent-like terminal curve, similar to the letter S, after I had vainly tried lengthening and shortening the spring. It will be seen, therefore, that under certain conditions, the place at which the spring is fastened, whereby it is given its tension and length, and upon which depends also its reduction into isochronism, can move within exceedingly narrow bounds. In this more had been lengthened and drawn in than could have been effected by the alteration of the curve.

Do not think, however, that isochronism can be obtained solely by the length of the spring; much also depends upon the mutual position of the places of fastening; upon this depends, first: To obtain the correct tension of the spring so that the large vibration arcs of the balance are performed in the same time, and to retain the correct places of fastening coinciding with the curve, which corresponds to this tension; and, secondly, to find the right point where, in a vertical position, in consequence of the contraction of the balance spring, the least pressure or the least friction of the pivots upon the sides of the jewel holes takes place. This point is very important; a diminished pressure makes the balance spring freer by small vibrations; by a larger pressure the balance spring cannot vanquish this friction, so that it is totally impossible to adjust in the different positions a watch with thick straight jewel holes. To make matters worse, these jewel holes are frequently set faulty, because the manufacturers, who use no olive-shaped jewel holes for the escapement holes, care little whether such holes are set oblique or straight.

For obtaining a good, durable adjustment, it is not a matter of unconcern what kind of motion the watch has, that is, how large the vibration arc of its balance is. If the parts of the watch, of the escapement, etc., are in order, and after having become satisfied by different tests, be it either by mounting a weaker mainspring or by winding or unwinding it, of the isochronism of the larger and smaller vibrations as well as in the different positions, it is best to reduce the vibrations of the balance to  $1\frac{1}{4}$  revolutions by mounting an appropriate mainspring. Ordinary anchor watches with flat spring also stand adjusting well with this motion.

We will mention still another peculiarity, the so-called "setting" of the balance spring, which becomes apparent especially in the most difficult and closest adjustments. The watches will retain their adjustment well for a few weeks, after which they will insensibly commence to accelerate, until finally, at about the end of a

year, they have attained the maximum; this is due to a molecular alteration of the steel in the balance spring, which will attain its limits only after a continued activity of the spring, when the watch will retain its adjustment to which it is subjected subsequently. I do not know whether balance springs, made from any other material beside steel, will show this peculiarity of accelerating.

If a complete isochronism could be established simply by the length of the balance spring, then the use of a flat spring would possess various advantages over an over-coil, because the latter is adjusted with far greater difficulty. I have often heard the assertion made that it was an easy matter to obtain isochronism with a flat spring, and it is indeed a matter of fact that a flat spring can be recommended to the watchmaker who is not initiated in the manipulations necessary for an over-coil spring. But in spite of this, I have not yet heard the assertion made by an adjuster, that is, an artisan who is exclusively engaged in timing the finer kinds of watches and marine chronometers—and it can be assumed that they possess a certain experience in their business—that a flat balance spring is preferable. It is beyond dispute that excellent results can be had also with a flat spring with one-half the difficulties of an over-coil, since it is necessary only with the former to operate without regard to the knee and the terminal curve, and it requires simply to draw in or lengthen out, whereby is finally found an approximately suitable place of fastening—and with the latter, the length is an important factor in establishing isochronism. When, however, the assertion is made by watchmakers who proclaim the advantages of the flat over the over-coil spring, the experienced man is really at a loss what to admit most—their inexperience or their cheek. When they thereby base their assertions upon the English watch with flat spring as support, and upon their fame of being closely adjusted, which, by the way, is much exaggerated, I am almost ready to assert that these acceptations are due either to national pride\* or still more upon hearsay and suppositions than upon proper experience. It is true that there are many closely adjusted English watches with flat spring, but this does not yet prove by any means that they are better regulated than good Swiss, French or German watches.

\* \* \* \* \*

But to return to the balance spring, of which there are three different kinds: the helical, generally used in chronometers, the over-coil or Breguet, in fine duplex and anchor watches, together with compensated balance, and third, the flat, less often employed for very close adjustments, but otherwise used in more current watches.

The helical spring unites all the requisite details with which to obtain isochronism.

The over-coil can be used for establishing isochronism, by closely keeping in view all the details necessary therefor, especially by a proper fastening and by an exact execution of the theoretically correct terminal coils.

The virtue of the flat spring for establishing isochronism is still a matter of dispute. While some declare it to be totally unfit, the contrary is proven by the close adjustment of the fine Patek anchor watches with flat spring. It is indisputable that in the hands of a skillful adjuster the over-coil spring renders the closest results obtainable; but a practice and experience of many years are necessary to do this, and unskillful hands, that attempt to meddle with such work only occasionally, can ruin the adjustment forever. A less expert but intelligent watchmaker can establish a fairly good isochronism with a well layered balance spring—one that is well suited, in point of length and thickness, to the balance and its number of vibrations. It is altogether impossible, however, to establish any rules whatever governing its length, thickness and number of coils.

\* I remember a resolution in the British Horological Institute, of Sept. 21, 1866, which was adopted unanimously, as follows: "The meeting is of the opinion that the special preference of the English watches consists in the fact that their escapement is of the best material and execution, and that up to date the English stand unapproached in this regard, and it is the sense of this meeting that these advantages be brought to the knowledge of the public."



This is proportioned to the existing power, kind of construction of the watch, size of arc of vibration, size and weight of balance, and can, according to circumstances, vary between 9 and 13 coils.

The anchor watch, which is the best for the ordinary every day's use, has to contend with the single defect that the friction of the escapement parts is proportionately large and must be overcome by the addition of oil. As soon as the oil commences to thicken the adjustment is often altered, and an early cleaning becomes necessary. Many shifts have been introduced to reduce these frictions to a minimum, by weakening the scape wheel points, rounding the pallets, etc., but in spite of this, the oil and dirt will always offer the greatest hindrances to a thorough and continued adjustment.

I would finally make a few remarks on cylinder watches. The opinion is frequently expressed, by otherwise capable watchmakers, that a mediocre cylinder watch is preferable to a mediocre anchor watch. I, for my part, prefer a mediocre anchor movement to a good cylinder, and I will say why. An anchor escapement, the single parts of which are suitably proportioned to each other, can always be adjusted more easily and for a greater length of time than a good cylinder escapement; the former is an escapement with free detent, the latter one with frictional detent, the friction of which will change unequally with time and give rise to most provocative disturbances. Nor is a compensated balance of any use in a cylinder watch, and next, the pressure exerted by the escape wheel upon the cylinder constantly presses the balance pivots to one side in the jewel holes; and the vibration of the balance, which is never detached, can never be as large as in anchor movements, etc. In consequence of these varying imperfections, we will find very great differences in cylinder watches, due to the influence of corporeal heat. If a cylinder watch is exposed to varying degrees of heat, a difference of rate of from 4 to 7 minutes can be found in temperature extremes of 30 degrees.

Every watchmaker can make this test and even more. A cylinder watch which performs well when worn by one person will fail to do so with another. The number of hours it is worn each day, whether the person moves much or not while wearing it, whether it is constantly worn in the same position and various other points must be duly considered in the adjustment of a cylinder watch. Long, irregular travel by rail, riding or an occasional non-wearing of the watch will produce irregularities. The layman, even, knows what a great difference upon the adjustment of such a watch is caused by the passing from one season into the other.

I beg to be excused from expressing my opinion of ladies' watches. Every watchmaker knows to his heart's content, or rather discontent, what an unpardonable treatment watches experience at the hand of ladies. Many of them consider them only an article of personal adornment or toy, which is hauled forth in a moment of whim or thrown aside, and then, if it does not go, the watchmaker is blamed.

The opinion that a watch should occasionally rest appears to be entertained by many; the watch is then not wound for several days, or, at least, permitted to run down; nothing is more erroneous than this. The regularity of the rate of a watch increases with the regularity with which it is wound every 24 hours; the more uniformly this is performed the more uniform its service and the more correctly it goes.

According to the kind of construction of a watch, the difficulties experienced in adjusting it in the positions augment or diminish, if the cylinder and scape wheel stand in straight line to the push-button, so that the wheel teeth exert a constant pressure upon the cylinder while the watch is hanging; the friction of the balance pivots on the sides of the jewel holes is smaller, and the watch may gain as much in a horizontal as in a vertical position. As a proof that the construction of a watch has much to do with the facility of regulating, it is simply necessary to bring it into some other position, say the VI above, and a considerable difference will be noticed.

I would advise to poise the balance exactly, to lay the balance spring well and to center it; if the watch advances more in lying

than in hanging, make a dot with a small round chamfer upon the upper half of the balance when the watch is suspended; but be careful to remove only a little at a time, so that it is not necessary to take away a quantity from the lower half for correction as the balance would become too light thereby. If, on the contrary, the watch advances more in lying than in hanging, take a bare trifle from the lower half. This remedy, of course, is only a make-shift, because when the watch is worn no care is taken to always keep the XII undeviatingly above; but, nevertheless, a sufficient degree of regularity can be produced hereby. It is advisable that the watchmaker request his customers to place their watches, when not wearing them, in the same position they assume in the pocket, that is, to hang them up.

Another point in the adjustment of a cylinder watch must be remembered: the influence of the heat of the body upon the rate, when wearing the watch; it is best to adjust it so that it will advance from 30 to 80 seconds in 24 hours, according to its kind.

I hope I have given a few data to beginners in the art of adjusting, and although I know that experienced timers will hardly have found anything new in my remarks, still, they will waste no time by reading them.

While recommending the prize essay of Mr. Immisch to the careful perusal of my friends, I will conclude by quoting from him:

"Regulating cannot be learned from books; practice and experience must contribute their part to enable the artisan to do his best in each case, and to obtain the best possible results from every watch."

[THE END.]

---



---

## Fashions in Jewelry.

---



---

### A Lady's Rambles Among the Jewelers.

THE season of 1884-85 will long be remembered by importers and producers of fine goods in all departments of manufacture, as "the rich man's poor year." In a word, unusual economy has marked a class of trade proverbial for its prodigality. With this state of affairs jewelers and silversmiths, whose stocks represent luxuries, expected almost no trade at all during the holiday season just passed, while, in point of fact, they had a relatively good one, by which is meant large sales as compared with luxurious and fancy goods in other lines of manufacture. The poor rich man, it is true, contented himself with spending hundreds of dollars where he was wont to spend thousands, but then there was a largely increased trade among many buyers who last season sought their Christmas presents outside of the jewelry stores. In a word, through all the unusual depression New York jewelers have had cause to realize the fact that the "boom" in jewelry across the seas has touched our shores. In New York city the wave is very perceptible, though in localities far removed from great business centers it is scarcely felt yet as a ripple.

\* \* \*

\* \* \*

\* \* \*

RETAIL houses that cater to the requirements of an exclusive fine trade feel the pulse of the people, perhaps, more correctly than any other class of jewelers, for their patrons are the ones after all who set and accept such fashions as a little later on have a run with what is termed the popular trade. Several members of leading up-town firms, in conversation with the fashion writer of THE CIRCULAR, have substantiated the statements made in this journal, that a revival of jewelry has come, and the only reason why a strong reaction in favor of jewelry did not take place this autumn is to be found in the finan-

cial condition of the country. Everything else favors it, and the authorities referred to look for a revival that will be felt from Maine to Texas not later than the fall of 1885.

\* \*

\* \*

\* \*

RETAIL dealers report a very material increase in the demand for all classes of jewelry, especially the beautiful flower patterns in gold jewelry, which this season have employed enamel and small gems in its ornamentation with such successful effects. There is a decided increase in the demand for bracelets and necklaces, two articles that have suffered much depression the past few years. In bracelets, while the newest patterns are flexible ones, such as the chain and link bracelets with and without gems, there is a popular run being made on bangle bracelets and the simple wire band bracelets with top finish of a flower pattern. Bracelets set with gems, by the way, show a decided tendency to Oriental taste in the association of many colored stones, and the elaboration of the gold bracelets. An importer for an up-town retail house, in connection with the subject of bracelets and chains, expressed himself as prepared to sell, one year from now, opera chains and broad band bracelets. This is possibly putting the matter too strongly, but there remains no doubt about bracelets and necklaces being in increased demand. A visit to any fashionable modiste's establishment will convince the most sceptical that these ornaments are required. With low-cut corsages and short elbow sleeves necklaces and bracelets must be worn.

\* \*

\* \*

\* \*

THE florists who reaped their golden harvests while the manufacturers of gold jewelry were most keenly feeling a depression in their business, are now complaining of the present style of corsage which prevents ladies from wearing the huge corsage bouquets that flourished at the balls and operas last winter. Colored gems, mounted in artistic settings, have taken the place of nature's ornaments, not only in the lady's corsage but in her hair, which last fact accounts for the demand for decorative hair pins. Among the very newest designs in these pins are knots and twists of gold mounted on tortoise shell pins. These knots are very effective, especially when studded with gems. Another favorite is represented in hairpins mounted with a flower piece imitating in its colored enamel a daisy, a rose, a rich hued pansy or a lily. When jewels are dropped in the heart of these flower pieces or glisten like dew drops in their leaves, the flower is set on a flexible stem so that it quivers with each movement of the wearer's head. In this connection may be mentioned, as a straw indicating which way the wind blows, the occasional appearance of back combs for the hair in beautifully wrought work.

\* \*

\* \*

\* \*

THE pendant is a popular ornament worn suspended from a gold chain or a necklace of single stones. It is also frequently worn at the throat as a pin; indeed, so popular has this habit become that many of the more enterprising retail houses are forcing quite a trade in pins, holding a middle ground between the favorite lace pin and the brooch. The flower pins first claimed this conservative place and are all the while gaining favor; and now comes the knot pin in a variety of graceful shapes and diversity of ornamentation. In illustration of the growth of these and other styles in conservative pins may be described one seen recently which certainly would not have been made without more or less faith in its success. The pin in question measured about one inch in length, was composed entirely of gems and simulated a fly. Two immense diamonds formed the body, one being of that peculiar green so highly esteemed by connoisseurs. The

wings were composed of brilliants and two rubies formed the eyes. Twenty-five hundred dollars had been put in this pin by a dealer who confidently expects the brooch next autumn, and had already found a sale for his hybrid pin. The advance of the shorter pin, it is believed, will affect but little, if any, the popularity of the lace pin, which is too convenient and practical an article to be banished. The same may be said of the little bonnet pins which ladies of means literally buy by the half dozen.

\* \*

\* \*

\* \*

IMPORTERS of colored stones, as well as the dealers who sell them to the retail trade, report these as more fashionable than ever, and likely to continue in demand with the present tendency to Oriental styles in jewelry. With the natural law of demand and supply, colored gems of fine quality, other points being equal, rank highest in price. The emerald, without a flaw, rarest of all, comes first, then the ruby of perfect tint, after which colored diamonds and pearls of desirable size and hue. In diamonds, colors much prized are a clear green and pink. The black pearl, when perfect, ranks first among pearls, generally speaking. All rare gems have advanced somewhat in value, while smaller stones and those imperfect in luster and color are decidedly cheaper. The sapphire, which a few years ago was comparatively rare and consequently high-priced, is at present a very popular stone, and this, too, at a cost reduced. The occasion of the change is the opening of new mines, which have thrown additional stones on the market. Fine opals are of rare occurrence, and there is a demand for these at good prices in spite of a foolish superstition that has, in times past, affected the popularity of this most beautiful and human of gems. The opal is usually associated with diamonds. Favorite associations in gems are diamonds and rubies, and pearls and diamonds. A necklace illustrating the latter, consists of small diamonds finished in front with three large colored pearls, one pink, one gray and one yellow, each pearl being surrounded with brilliants. In selecting opals it ought to be remembered that they vary as much in the display of brilliant colors as in their enduring qualities. The precious opals of Hungary stand first in the list, being harder as well as more brilliant than the Honduras opals. The former are usually of a bluish or yellowish white color, yellow by transmitted light, show a beautiful play of brilliant colors owing to minute fissures which refract the light. Care ought also to be exercised in the selection of sapphires. The desirable sapphire is of good color, highly transparent and brilliant. The blue sapphires of Ceylon have gained high reputation, and are, as a rule, the finest, though there are some excellent specimens in the market from the Burmah mines.

\* \*

\* \*

\* \*

THE fanciful origin and nature of jewels is an interesting study, and the magical quality ascribed to gems in the days of superstition and ignorance have followed the stones with a strange pertinacity up to the present time. Diamonds, called by the early Christians the "crystalized tears of angels," is the emblem of true happiness and purity; hence its preference for the engagement ring. Pearls, believed by the Russians to be drops of water that had been crystalized in the oyster, are emblems of innocence and modesty. The ruby, which in Burmah is thought to be a human soul in its last stage of transmigration before entering Buddha, is deemed a sacred stone which imbues the wearer with courage and noble instincts; an Oriental ruby, therefore, was early worn as a talisman. Opals, in ancient days, were regarded as royal gems, and attributed by the Greeks to be little fragments of the car of Pherbus or the sun. Originally this stone was accepted as a love gem which inspired hope and dissipated melancholy. Then followed the foolish superstition regarding its bringing ill-luck. This latter, fortunately, is dying out, and the old love gem with its incomparable beauty is again showing

its ever-shifting tints in rings, pendants and bracelets. The emerald, supposed to be far-reaching in its influence for good or for ill and ascribed to be the amulet of Venus, was thought to possess the power of making others love the wearer. Among highly moral stones rank the sapphires, which were early accepted as the jewel for the priests and saints to wear, the superstition being that the gems insured the fulfillment of prayers, preserved chastity and gave freedom from enchantment.

\*  
\* \*

\*  
\* \*

\*  
\* \*

THE holiday season brought about a number of cheering developments to the manufacturers of jewelry. It established the popularity of several new comers in way of adornments. Conspicuous among these is the Langtry chain in gold, silver and black jewelry, which many thought would prove only the fancy of a season or two. The leading retail houses of this city that have been interviewed on the subject of articles in jewelry which sold best during the holiday trade, with one accord report the Langtry chain, flower-pins and artistic designs in other short pins, chain and link bracelets and bangle bracelets, gold beads and silver jewelry in curio style as objects meeting an active demand.

\*  
\* \*

\*  
\* \*

\*  
\* \*

AN exceedingly fanciful pattern among flexible bracelets, by the way, borrows its design from the Langtry watch chain. It consists of four slender chains which fasten around the arm and drop in short lengths terminating with four gold balls. Another popular design is a gold wire bracelet with a top finish composed of a tiny pink shell on which rests a pearl. Beautifully tinted shells, decorated with pearls and diamonds, are also attractively employed on lace and scarf pins. Among new designs in bracelets is one representing a whip, the jeweled handle forming the top of the bracelet and the leash winding around the arm. There are also combination lock bracelets which open on the word "Hope" or "Love," and likely to prove popular as engagement tokens.

\*  
\* \*

\*  
\* \*

\*  
\* \*

MANUFACTURERS of all classes of jewelry who have kept pace with the progress of the times understand that a revival of jewelry and the growing tendency to Oriental tastes does not mean a return of the cumbersome and massive styles which went out when the "artistic craze" came in. People have advanced in their tastes in personal ornaments just as they have advanced in matters pertaining to household decoration, and the most popular articles to-day in gold jewelry owe their popularity to their graceful and beautiful patterns and the excellence of their workmanship. A pretty style of necklace that is gaining ground is made of arrow heads placed on a slender gold chain. The same idea is also carried out in bracelets and necklaces. If gold necklaces are to follow gold beads, as many believe, these must be produced in unique designs possessing artistic merit. The same may be said of the brooch for which there exists splendid possibilities in the near future.

\*  
\* \*

\*  
\* \*

\*  
\* \*

THE old saying as "untrustworthy as a lady's watch" has lost its significance in these days of correct timekeepers for everybody. Ladies' fine watches are now made with minute repeaters striking the hour, the quarters and the minutes. There are also perpetual calendar watches, with phases of the moon, showing also the days of the week, days of the month, and, in fact, the leap year, bringing out the

29th day of February. Ladies' watches range in sizes 10, 12, 13 and 14 line. Of late years the demand has been for watches in plain cases with monogram engraved thereon, and this style remains a popular one. There is also a demand for watches inlaid with diamonds and other precious stones; not in rose diamonds as heretofore, but brilliants, with the lid of the case pierced through, thereby introducing much more beautiful effects. Quite new are neat little watches with calendars that recall appointments made by forgetful ladies on certain days. A pretty little clock imported for the holiday trade and called the "Babé" is only two inches high, although an eight-day timekeeper. In form it follows an upright clock, the four sides or pane's being beautifully painted and otherwise decorated in gold and enamel.

\*  
\* \*

\*  
\* \*

\*  
\* \*

THE English crape stone jewelry, though of comparatively recent introduction, is already well known and popularly received by the retail trade of the country in mourning goods. As the name implies this jewelry presents a surface simulating that universal symbol of deep mourning, fine English crape, in hue, finish and sheen, and is sold on crape bordered cards. This jewelry is made in onyx and jet and is susceptible of elaboration in pattern and by the association of pearls. It presents several grades in quality thereby affording a popular grade in prices. There is manufactured a complete line of these goods, including lace pins, ear drops, bracelets, scarf pins, sleeve buttons and the like.

\*  
\* \*

\*  
\* \*

\*  
\* \*

THE great army of holiday shoppers did not all linger over the jewelers' show cases. Silversmiths deserved and gained a good trade. Retail dealers who were not well stocked with new styles in table ware and popular articles in fancy wares had only themselves to blame. Manufacturers prepared novelties in all departments of silver goods, and many of them were of such convenient and practical nature they could not fail to meet the requirements of a large class of holiday shoppers.

\*  
\* \*

\*  
\* \*

\*  
\* \*

IN sterling silver new tea sets show in their decoration a revival of the old English *repoussé* work, both with and without the oxidized finish. This oxidized *repoussé* work, it is thought, will take well, not only because it is decorative, but because of its enduring finish, which requires less care on the part of the housewife than some other styles, and grows more attractive with age. The fluted finish of Queen Anne's reign is also re-introduced in solid ware, where may be seen, too, an occasional example of the more ancient Indian chasing, and, now and then, specimens of Japanese decoration. The satin finish is still produced to meet the demand that remains for it. In presentation and fancy pieces, ornamentation occurs in applied work and the employment of gold and other metals. Popular articles in table ware are after-dinner coffee sets in Turkish and Moorish designs, and water pitchers modeled after classic shapes. These after-dinner coffee sets, with their tall, slender forms, are quite at variance with the low forms prevailing among most articles of silverware for the table. The present fashion admits of not more than three high pieces, and often only one is used. These are epergnes or fruit stands, and are placed in the center and at the ends of the table. These flower and fruit stands are often very decorative, being ornamented with applied work in fruit and flower designs. New patterns in spoon work are attracting attention, not only at home but abroad. In some of the more elaborate patterns the central figure in each spoon is unlike any of its fellows, presenting various phases of social

life in the times from which the designs were modeled. Children's sets, piece by piece tell, in illustrated story, the varied fortunes of Peter Piper and other nursery heroes.

\*  
\*\*\*  
\*\*\*  
\*\*

THE cosy English fashion of making tea on the table, which has gained some favor here, has brought out, both in sterling silver and fine plate, many beautiful designs in swinging kettles and caddies. This season comes, in this connection, the tea-ball, a Japanese idea. This ball is made of open silver work and hangs suspended from a silver chain; the tea is placed inside the ball, the ball dropped into the urn or kettle of boiling water where it remains until the tea is "steeped," when the ball is withdrawn, leaving the beverage quite free from leaves.

\*  
\*\*\*  
\*\*\*  
\*\*

IN FINE plate ware are to be found the prevailing low shapes and new style of finish that characterize the solid silverware. Indeed, it has become an undisputed fact that plated ware produced by leading manufacturers is not only marked by its excellent wearing qualities, but by good forms, new styles of finish and artistic ornamentation. The advance made by these manufacturers is briefly told in the fact that twenty-five years ago English manufacturers were depended upon in this country for fine plate goods, while now only an occasional piece of English ware is seen, and an export trade to markets formerly held by England is increasing each season. In silver plate ware the variety of finish gives a wide field for selection. In addition to the *repoussé* and fluted work, occurs the damascene engraving associated with fine die cut border. An attractive style of decoration, also new, is that of bright cut engraving on a satin finished surface. The satin finish, which remains popular, is often associated with the plain finish, the latter occurring on the parts exposed to most wear. Oxidizing and copper are much employed for the decoration of silverware, especially such articles as gift pieces, and flower and fruit stands.

\*  
\*\*\*  
\*\*\*  
\*\*

NOT only do the manufacturers of fine plate ware afford their patrons the choice of new forms and styles of decoration, but they produce all the classes of articles to be found in sterling ware. There are not only solid silver manicure sets, shoe lifts and buttons, brushes with solid silver backs and handles, shaving and toilet sets of pure silver, but in heavy plate as well, and showing the varied styles of finish. The articles here mentioned, by the by, were fairly popular ones with holiday patrons, and commend themselves as desirable additions to every retail dealer's stock. The same may be said for the very full and varied line of individual "peppers" and "salts," breakfast and other small casters.

\*  
\*\*\*  
\*\*\*  
\*\*

SOME of the most popular articles in silverware were the hardest to introduce. Every manufacturer will remember the brave struggle made with the public before the pickle stand, of English origin, gained a wide-spread recognition. To-day the retail dealers do not handle a more popular object, unless it be the necessary butter dish and cake basket. Cake baskets, by the by, should be in every jeweler's store, even though the town in which said store is located does not number more inhabitants than the fingers on one hand. Why it is remains a conundrum, but it is a fact that every country housewife covets a cake basket, and is not quite content with her table

ware until it embraces this article. The best styles in cake baskets, it may be explained in this connection, are the low shapes. Another article of practical nature difficult to introduce, but very popular now among the city folk, is the baking dish. Vegetable dishes are also in high favor. These dishes are not very ornamental, but when made of good plate are enduring, outlasting many sets of porcelain ones and proving cheaper in the long run. Of an economical nature, too, are the silver plate water pitchers, which last a life time, and lend attractiveness to the table with their beautiful finish and artistic forms. For water pitchers the demand is all the time increasing.

\*  
\*\*\*  
\*\*\*  
\*\*

EVERYBODY may not know the prominence which American cut glass has attained in the world of fashion. Dealers in choice china and glassware in this city are selling it to their most fastidious customers, who select it when lying side by side with that of English manufacture. Manufacturers of sterling silverware are very generally adopting it. A prominent manufacturer claims that the finest quality of American cut glass, which, it may be explained, is made in this State, gives equal satisfaction with the better grades of English glass, and is used in preference by him. Fine colored glass suited to toilet sets, vases and the like, our jewelers and silversmiths, however, are obliged to import. While on the subject of glassware it is only fair to add, that from Pittsburgh comes a remarkable quality of pressed glass closely imitating cut and engraved glass. The association of silver and glass is an important one, representing not only the usual table pieces, such as casters, epergnes, pickle and cheese dishes, and ice cream and confection plates, but decorative household articles like vases, toilet sets, perfumery bottles, liquor flasks and pungents.

\*  
\*\*\*  
\*\*\*  
\*\*

AMONG silver articles in jewelry that had a great run during the holiday season were silver lace pins in curio style. These reproduce in design antiques, such as old coins, bits of remarkable frieze and models from the British museums. All the antique styles show the oxidized or old silver finish which insures each piece growing more and more attractive with age. Silver Langtry chains also had a run, as did silver bracelets. Novelties in scarf pins showed small antique silver coins mounted in gold. Curiosities in way of silver match boxes and cigar cases are those covered with coins, oxidized so as to represent great age. A unique pin cushion designed for gentlemen's use, is composed of a tiny roll of blue or red velvet wrapped around with a split trade dollar. Another new pattern comes in form of an owl's head in silver with amber eyes. Match box, seen, represents a piece of Fabers' rubber, the wood part being of copper and the rubber portion of silver.

\*  
\*\*\*  
\*\*\*  
\*\*

THE individual "salts" and "peppers" which are out this season in a greater variety than ever, are having a run that reaches more homes, perhaps, than any other modern article of table ware. These goods represent such a wide range of prices that there remains no reason why every retail store, however small, should not possess a full stock of them. With this suggestion may be safely added another to out of town retail dealers. In buying any class of goods, however small in price, have a care to buy silver plate ware of trustworthy manufacturers only, even if you pay more for it. Articles put on the market without the stamp of a good house, mean that no one is willing to be responsible for their manufacture; certainly no dealer can afford to run the risk of selling such goods. Leading manufacturers are all plating on white metal and produce what is termed by some "quadruple plate," in reality a plate 20 per cent. purer than

the old triple plate, and representing the best quality made. One word more. Manufacturers each season incur heavy expense in bringing out new designs. The better class of people in your town, in these days of rapid transit and cheap rates, keep pace with the fashions and want the new things. If they do not find these new goods on the resident jeweler's shelves these jewelers do not get their money, but it goes to the nearest large city. A word to the wise is sufficient. Take advantage of the cheap rates yourself once a year, and through your own eyes learn what is going on among the leading manufacturers of jewelry and silverware.

ELSIE BEE.

### Pearl Fisheries on the Pacific Coast.

ABOUT 100 years ago Juan Oxio first called attention to the vast source of wealth concealed in the mud which lay at the bottom of the waves of the Gulf of California adjacent to the eastern coast of Lower California. He discovered there immense beds of the pearl oyster and realized great wealth. He fished principally for the black shell (Conchanacar), which is found in great quantities from San Sebastian Bay to the mouth of the Rio Colorado. After his death the industry was followed in a desultory fashion until about 1859. From that time till 1872 it was pursued in a more systematic manner, the trade, however, being practically monopolized by the agents of wealthy European houses, who established themselves on the lower peninsula, and purchased the pearls and shells on the ground as soon as removed from the water. About that time some of the merchants of La Paz discovered that they could deal directly with Paris, London and Hamburg, and save the profits of middlemen, and the European agents were, so to speak, starved out. Still the fishing was conducted on the old and time-honored system of using divers trained by long experience to remain perhaps two, or at most three, minutes under water.

In 1875 two schooners, each of about 200 tons, one from Australia, the other from England, went to these waters, liberally supplied with diving apparatus, helmets, rubber suits, hose and life lines, and thirteen boats and boats' crews to operate them. With the aid of these appliances they made a clear profit in six months of \$125,000. The merchants engaged in the fisheries purchased the diving apparatus from the schooners, and since that time the diver's helmet has driven the unfortunate individuals who made their living by holding their breath entirely out of the pearl-fishing fields of labor. But the advantages possessed by the pearl fishers of La Paz were advantages which might be shared in common with any other persons who could command the capital necessary to go into the same business. The idea of seeing strangers and aliens come in and scoop up from the bed of the gulf the wealth which they were beginning to regard as their inalienable inheritance was intolerable. But how to avoid it was the question. That conundrum was soon solved by the elevation to the Mexican Presidency of General Gonzales. That gentleman was applied to, and by "proper representations" his favorable consideration was secured and given to a plan by which, on the 28th of February, 1884, five concessions were granted to five gentlemen. The concessions give these gentlemen, their associates and assigns, the exclusive right and privilege of all shell fisheries in their respective zones for the period of sixteen years, paying therefor a royalty and export duty in full of all claims of the government, amounting altogether to \$10 a ton on all shells exported for the first three years, and \$15 a ton for the remaining thirteen years.

The holders of these concessions immediately consolidated their interests, as no doubt was the original intention, and dispatched Juan Hidalgo, armed with powers of attorney and all necessary credentials, to obtain the capital necessary to systematically work one of the most gigantic schemes of monopoly which the world has ever seen. Senor Hidalgo's efforts in San Francisco have been suc-

cessful, and in July last, under the modest title of the Mother-of-Pearl Shell Company, a corporation was formed under the laws of California, with Juan Hidalgo as President, George W. Watts (General Freight Agent of the Union Pacific Railway) as Secretary, and D. Samuels, R. E. Phillips and Julius Jacobs as directors, with a capital of \$500,000. It is hinted that in addition to the foregoing names a number of our prominent capitalists, among others ex-Governor Perkins, are interested as stockholders. As an evidence of the enormous profit to be made by this gigantic scheme, it may be mentioned that for the past two years the yield of the fisheries, conducted with four schooners and twenty boats, has been from \$200,000 to \$250,000 in pearls, and about 900 tons of shell, worth from £60 to £70—say £65 a ton, or \$292,500, making a gross yield of \$542,000 per annum.

The company has now four schooners on the fishing grounds, the *Porfirio Diaz*, the *Adriana*, the *Consuelo* and the *Paloma*. The fisheries are conducted as follows: Each vessel carries five boats, and each boat carries a crew of six men—a diver, two men to work the air pumps, one at the life line and two at the oars. The vessel having anchored on favorable grounds, the boats put off from the ship's side early in the morning. The diver is lowered and remains on the bottom for two or three hours at a time, and by 3 o'clock in the afternoon he has filled his iron basket with from seven hundred to two thousand shells. At that hour the shells are opened by the officers, who remove and retain in safe keeping the pearls, which are principally what are known as black pearls, of great rarity and value at present. The decks are then cleared up, and the shells consigned to the hold, and work discontinued for the remainder of the day. The pearls and shells are sold in the markets of London, Paris and Hamburg—principally London.

Preparations are being made by the company to send, as soon as possible, a large fleet of vessels, equipped with all the improvements in diving apparatus. As a further instance of the enormous powers conferred by the Gonzales Government on its favored monopolies, the holders of the concessions are authorized, without any process of law, by force of arms, if necessary, to arrest any person found fishing in the waters of the gulf without a permit or license from Senor Hidalgo, and his associates, or their assigns, and to seize their vessels and consign them to the Mexican authorities, to be dealt with according to Mexican law, and all custom-house officers on the gulf coast have been instructed to recognize the permits and licenses of the holders of concession, with the same effect as if issued from the fountain-head of the government.

### Proceedings of the Horological Club.

#### A DISTINGUISHED BODY OF WATCH AND CLOCK MAKERS.

*One hundred and twenty-sixth discussion.—Communicated by the Secretary.*

[NOTICE.—Correspondents should write all letters intended for the Club separate from any other business matters, and headed "Secretary of the Horological Club." Direct the envelope to D. H. Hopkinson, Esq. Write only on one side of the paper, state the points briefly, mail as early as possible, as it must be received here not later than the eighth day of the month, in order to be discussed and reported in the CIRCULAR for the next month.

#### WATCH CLEANING AS DONE IN WATCH FACTORIES.

*Secretary of Horological Club:*

I must beg pardon of "Mr. Clerkenwell" for not being more explicit in my last communication, but think he will excuse my shortcomings when I tell him it was my first attempt, and feared it would not find a place in your valuable journal.

In reply to his inquiries and criticisms I would say that this "wooden box" was for the purpose of holding the movement only, and was not to be "dipped;" and it was very convenient for keeping the different parts of the watch in such a manner as not to get as mixed as my communication appeared to be. I send you a rough

design of the aforesaid box, which I think will enable you to see more clearly what I wished to convey. I would also wish to say that steel works (except pinions) was not put into cyanide at all, but was washed in benzine and dried in sawdust; that the brass work was dipped into a weak solution of cyanide of potassium, not allowed to remain, then washed carefully and thoroughly in warm water with brush and soap, then put into alcohol and dried in sawdust. Balance was trued and poised, and the escapement adjusted before being cleaned. I believe a thorough understanding of escapements, etc., as very necessary, and is the most important part of watch repairing, for, unless the escapement is properly adjusted and the balance true and equally poised, it will be impossible for a watch to keep good time. It is not sufficient that the watch should run, but it must also keep correct time; and my experience in a job shop has been such as to lead me to believe that escapements are not understood by workmen as they should be. For those who might be interested, I would refer them to the design of escapement as published by The Fredonia Watch Co. as a study, and think that by understanding the same they will be more than repaid for their trouble. If they will understand the relations of the jewel pin to the size of slot in the fork, the guard pin to the roller, the banking to the lock, drop and slide of the pallet stones to the teeth of the scape wheel, and all other parts of the watch being equal as to correctness, I will guarantee that watch repairing will become more of a pleasure to them than it has ever been before.

These hints and suggestions without price or favor are given for what they are worth. No charge, and hope they are clear enough to set some one a thinking.  
X. Q. Z.

Mr. Clerkenwell replied, we are always glad to hear from our readers who have special information of any kind which will be interesting to the trade, whether it is obtained from sources not open to others or learned from their own experience or invention. Anything of the kind is sure of insertion in due time. Even when parties have new tools or attachments which they are manufacturing for sale, we are ready to publish descriptions with cuts if furnished us for that purpose. We would not, of course, insert advertisements of anything, but such information about the articles as will interest readers generally, we willingly give without charge. Whenever possible, a sample should be sent for examination to base the description upon. Let us hear from all who can tell us anything new.

It seems that the wooden box is not for dipping into the cyanide solution, but merely to hold the pieces before and after cleaning, having a place for each size of part. The object of cyanide is to remove stain and tarnish and give the pieces a bright fresh look. But great care must be used or it will take off the gilding entirely. Other cautions were given in the discussion in our Proceedings for December.

He agreed with Mr. Z. about the necessity of the watch repairer understanding escapements, etc., for no matter how clean and bright the movement may be, it cannot keep time unless it is mechanically correct. In fact, it is rather aggravating to have a watch look so awful nice when it is not worth a tinker's cuss for time. All repairing and correcting comes before cleaning, both in importance and in order of execution. Workmen who cannot repair a watch properly have no business to touch them for cleaning, for it is an imposition to clean them and leave them out of order. We hope Mr. Z. will give us items upon other matters of factory practice which are better or different from those usually followed by the trade.

#### BOOKS FOR WATCH REPAIRING.

##### *Secretary of Horological Club:*

Can any member of your honorable Club tell me where I can get a suitable book for recording the watches which we sell and repair.

A. W. JOHNSON.

Mr. Uhrmacher said that Mr. J. would find two or three fully described in our Proceedings in the back numbers of THE CIRCULAR, with methods of filling them out, etc., etc. He thought that it would pay the publishers of such works to keep a short advertisement in THE CIRCULAR as they are constantly wanted. The name and address of our correspondent are given in full, so that those who have such for sale may communicate directly with him. We will

also insert short notices of such in our Proceedings, if the publishers choose to furnish us the information.

#### EXCELSIOR'S TREATISE ON THE BALANCE SPRING.

##### *Secretary of Horological Club:*

I have lately been reading "Excelsior's" book on the balance spring, and there are some points in it which I do not understand and would like to have some member of the Club explain it.

On page 77, section 146, he describes how to make the curve for isochronizing the hair spring. Now, I do not see how the outer coil of the spring can be bent into the shape represented in fig. 7 without interfering with the other coils. Also I find it hard to tell the extent of vibration of a balance, as, for instance, in adjusting to positions he says that by watching the balance vibrate one can easily tell whether it will gain or lose in different positions. By explaining these the Club will greatly oblige  
J.

Mr. Isochronal replied that, in the case of a spiral or helical spring the coils would not touch, even if the outer one was bent in the center. When a terminal curve is formed on a flat spring, as in the Breguet form, the outer coil is raised up by an elbow or band, so that it lies *over* the other coil constituting the body of the spring.

To observe the extent of the vibration of the balance, run your eye around the rim and you will see some point, as a screw in the rim, a mark on it or the end of one of the balance arms, which can be distinctly observed when the balance stops and begins to turn the other way. Notice some stationary part that is exactly opposite or under that screw at the turning point of the vibration. Now, whenever that screw fails to reach that point or goes beyond it, you will see at once, and see how much it falls short or goes beyond it. By noticing how far the screw reaches in *both* directions, you have the extent of the vibration between those two points. If the screw reaches the same point from each direction, the vibration is "one turn." If it goes  $\frac{1}{8}$  of a turn further in each direction, that is  $1\frac{1}{4}$  turns; and if it falls short  $\frac{1}{8}$  of a turn both ways, the vibration is  $\frac{3}{4}$  of a turn. A little practice will enable you to notice the extent and variations, and to estimate the proportion of a turn.

#### THE BEST KIND OF OIL FOR FRENCH CLOCKS.

##### *Secretary of Horological Club:*

What is the best kind of oil for French clocks? One jobber wrote me clock oil, another wrote me watch oil. I refer the question to the honorable Club.  
E. K. B.

Mr. McFuzee said the proper kind of oil for clocks was clock oil. It was made, or should be so made, as to have more body than watch oil, which was thinner and better adapted for fine holes and slight pressure. The heavy pressure of clock pivots would be likely to force the thin watch oil entirely out from under it, and so defeat the object of oiling, which is to have a lubricating layer or film between the two solid surfaces.

As to the kind of clock oil, there are a number of good oils on the market. Moebius oil, sold by Keller & Co., 64 Nassau St., is highly spoken of, and the genuine Kelley's oils are known everywhere as good, and can be obtained from any respectable jobber. Only the best clock oil should be used on French clocks as they need something thin, but an oil really fit for watches would be too thin for clocks. Doubtless there are other oils as good as those named, but only such as are known to be good should be bought, whether for clocks or watches.

#### CURIOUS PHENOMENON IN WATCHES.—EXPLANATION WANTED.

##### *Secretary of Horological Club:*

As I have derived much information from your deliberations of late, I would like to further increase it by asking a few questions. A few days ago I took in a common cylinder movement to repair. After taking out the balance I wound the spring a little to see if the train would move, and if not, why. I found that the top jewel of the scape wheel was loose—in fact, so much so that it turned with the wheel, but to my surprise it turned in a *contrary direction*. At the risk of breaking a pivot, I wound the spring well up and found that the jewel increased its speed, but still moved in a contrary direction to the scape wheel. On taking out the barrel and moving the center wheel, I found that whatever way the wheel was made to

move, the jewel would go the other way. I would like to know what caused the seeming inconsistency.

I also send some specimens and questions for the *scientific member* of your honorable body. No. 1 is common enough, probably, as I have seen it in many different places. It is of all sizes and shapes, but always hollow; the inside being filled, when the rock has not been broken, with a red or yellow clay, which dissolves readily in water, which, on being decanted and evaporated, leaves a deposit perfectly free from sand or grit of any kind. To the outside of these hollow rocks are cemented innumerable large and small rocks like Nos. 2 and 3, etc. The surrounding earth is also filled with 2 and 3 of all colors and of different colors in the same piece. These are also found attached to the inside of the hollow rocks. So firmly are they fastened, both inside and out, that they cannot be detached without breaking the rock. The appearance of the No. 2 and 3, etc., would indicate the action of water, while it seems that nothing but heat could have so closely united two bodies of such seemingly different construction. The hollow rocks seem to have been forced into different shapes by some outside influence while in a plastic state and thus left to harden. Depressions on the outside have nearly all corresponding elevations on the inside surface. The strata is about two feet thick, resting on a soft sandstone rock in a yellow clay bed, about ten feet from the surface, where a wash has occurred in a hillside.

I would like to know the theory of the formation of these rocks, and the probable time it has taken.

S.

Mr. Ruby Pin, to whom this letter had been referred for reply, said he was unable to account for the reverse motion of the jewel. If what Mr. S. saw was not a reverse image reflected from the polished surface of the jewel, but there was really a reverse motion of the jewel, then it was a very curious phenomenon which he would have to leave to some one else to explain.

In reply to the other question, he believed that none of the members were acquainted with the science of rockology. He had asked a friend of his, and got an explanation so learned, profound and extended that it had quite upset him. He thought his brains were still a little muddled from the effects of such a deluge of scientific profundity, and about all he could remember of it was that the hollow rocks were of a chalky or limestone nature; that while soft they had either been expanded by liberation of carbonic acid gas from the carbonate of lime, or they had formed a sort of shell for some low order of primitive creature which had subsequently decayed, and all evidence of organic structure had disappeared. The other rocks were united to them by a clayey cement, by the action of water which had evaporated and firmly united them. They were subsequently washed down into beds or strata as found. They belonged to the silurian formation, which was of a comparatively recent date, say only five or six hundred thousand years ago, or such a matter—a mere trifle any way. In conclusion, he said he had manfully endeavored to accomplish the task imposed upon him, regardless of the risk to his mental solvency which he incurred thereby, but he threatened that a due regard for the interests of his family would compel him to resign his seat in the Club rather than again undergo such a trying ordeal.

Mr. Windbag, a new member, thought that the action of the jewel described by Mr. S. could easily be explained under the doctrine of the conservation of energy. No energy can be destroyed. It may disappear in the form in which it had before existed, but it was not annihilated—it had only changed its form, and an equivalent still existed in a different form of energy. As everybody knows, action and reaction are equal. So, when the kinetic energy revolved the wheel in one direction, as a result of its action, re-action would naturally tend to revolve the jewel at an equal speed in the opposite direction. As the jewel was free to move, in this case, the tendency was eventuated into an actuality. He saw nothing very wonderful about it. It was simply a beautiful illustration of the harmonious evolution of natural laws.

The other members blinked hard, but didn't quite seem to comprehend it. Mr. Ruby Pin showed signs of great mental agitation, and soon became quite incoherent in his remarks, declaring that he would move for Mr. Windbag's expulsion as an incendiary, and other

similar expressions indicating a disordered mind. His condition soon became so alarming that the Chairman sent a messenger around the corner for a pitcher of milk (at Mr. Windbag's expense), and the Club then adjourned in order to devote their entire attention to administering the soothing medicine to the sufferer. The Secretary is pleased to state that the medicine had the desired effect. Mr. Ruby Pin became reconciled to Mr. Windbag, and the members separated in a highly benevolent and Christian mood.

---

### Musical Boxes and their Manufacture.

A GENTLEMAN who recently visited Yverdon, Switzerland, where music boxes are extensively made, inspected the large factories of Messrs. Paillard & Co., and furnished an interesting account of his visit to the *Watchmaker, Jeweler and Silversmith* of London. We make the following synopsis of his letters:

I was first taken into the show room of instruments that were complete. The first musical box I examined had some special features well worthy of notice. Among others I may mention the size. It was unusually large; height, 4 ft.; length, 4 ft. 4 in.; breadth, 2 ft. 5 in. The style is that known as Louis XVI., which aims more at grandeur than solidity; there is a lightness and a delicacy in the design which makes it specially suited to the drawing-room. It was made of ebonized Spanish mahogany, profusely inlaid with figures of brass, ivory and mother-of-pearl, all of which were exquisitely engraved. The edges, escutcheons, feet, etc., were of solid cast brass, richly chased and water-gilt, and finally covered with a thin transparent lacquer which effectually prevents tarnish. The workmanship and beauty of finish were of the highest possible order, and it would be no exaggeration to say it would grace the best room in Marlborough House or Windsor Castle; but its chief glory is its music. I can feel its wondrous and ennobling power, and yet my pen is paralyzed and powerless when I try to describe it. It commenced by playing a simple yet plaintive air, and it produced a peculiar lingering effect similar to a band of music that is traveling, and eventually the tune is lost in the distance. And just when I thought the performance had ended, it suddenly burst forth with a volley of sweet thunder, and for a moment I feared that some of the machinery had given way, and the energy of the four great mainsprings that were driving it was about to work speedy destruction, but was soon reassured and again enraptured by the grand chorus which gradually became lower, and then lingered and at last died away; and I listened and listened, hoping to hear a repetition of the sublime harmony.

The playing this air occupied about fourteen minutes without any cessation, and this brings me to consider a new feature in musical boxes, the introduction of which is due to Messrs. Paillard & Co. An ordinary box with the largest cylinder made, diameter, 36 lines, or  $3\frac{1}{4}$  ins., playing at slow time, occupies about one minute and eight seconds to play each air. The mechanical combination employed by Messrs. Paillard & Co. for playing long pieces of music without intermission, consists of a duplex cylinder operating upon two separate combs. In the spaces between the wheels at each end of the cylinder will be found the ordinary arrangement by which the barrel is shifted for playing a fresh tune; but they do not operate simultaneously; the one at the extreme left operates first, and while this barrel has ceased to play and is being shifted for a fresh part of the air, the strain is continued by the barrel on the right hand; immediately the left hand barrel resumes playing, the right hand barrel is then shifted, and they accompany each other. Anything more simple or more mechanically perfect it would be difficult to conceive. The proprietor was kind enough to give me the history of this invention. It appears the first idea occurred to Mr. Amedée Paillard, in the year 1873, while employed in constructing a magnificent musical box for the Philadelphia Exhibition, valued at £1,200.

But the mechanism he suggested was perfected and simplified by a St. Croix workman—a Mr. Jeanrenaud, recently deceased, who sold his invention to the firm of Messrs. Paillard & Co.

When Sir Edmund Becket was designing the celebrated Westminster clock, he experienced what all makers of quarter clocks have experienced—a difficulty in getting machinery to chime the four quarters in equal periods of time. He found that the heavy bar in the first quarter greatly retarded the progress of the fly, and consequently it was played at very slow time; but the fly having to some extent got up speed, the second quarter was played in much less time; the third was quicker still; and the fourth so quick that it completely destroyed the effect. After trying several expedients, he at last adopted what Vullamy had long ago suggested, viz., to increase the size of the fly and its number of revolutions, and also increase the motive power until the desired result—perfect time—had been obtained. Sir Edmund has more than once acknowledged his indebtedness to Vullamy, so that the charge of plagiarism cannot be preferred. The mechanical principles which underlie the foregoing remarks on the fly is precisely what this firm have adopted in all their large musical boxes—abundance of power, with a very large fly measuring  $5\frac{1}{2}$  inches by  $2\frac{1}{2}$  inches. Instead of the old expanding fly they have introduced a new and very ingenious device, which consists of two wings joined together, and may be shifted from a vertical to a horizontal position for the purpose of regulating the time.

The enormous power required in their large boxes is obtained from four large barrels operating in one pinion; the diameter of each barrel is  $5\frac{1}{2}$  inches, and the width  $3\frac{1}{4}$  inches. The advantage of this combination is this: the main springs are all broad and thin, and on this account are not likely to break. I estimate their combined force at four hundred pounds, and though the power is so great, yet by the combination of levers attached to the barrels they may all be wound at once by a child.

The fly is in a vertical position for playing at slow time; but by moving the screw near the top pivot down the slot the wings take a horizontal position, which, in rotating, experiences little atmospheric resistance, and consequently increases the speed. The advantages of this arrangement over the old style are these: It is perfectly noiseless. The whizzing sound in the old fly often arises from the unequal positions of the wings, and forms a most unpleasant accompaniment, especially when the music is soft and smooth, and is more easily shifted, which is a great convenience to those who are not familiar with mechanical operations. It is made in a very fine press tool, out of one piece of sheet brass; so that its parts are few and cannot easily be broken. In its performance I could not detect the slightest hesitation even in the heaviest bar of music. By using this fly a musical box may be made absolutely perfect in time; so perfect, that the most accomplished performers, vocal or instrumental, cannot hope to rival it.

But while a musical box has many great advantages it has its weak points also. Hitherto it lacks expression. I shall be allowed to explain that this word expression is employed to represent, not the mere act or power of uttering articulate sounds, but rather the *manner* of doing it, so as to produce a striking effect and forcibly appeal to the feelings. As in reading and declamation an accent or emphasis is laid upon particular words and syllables, so a similar force of expression is given to certain notes in music. *Expression* constitutes one of the first requisites of a musical performer; and though attention to the rules of art may assist, yet, to give it due effect, much must depend upon feeling, taste and judgment. A master in music will sometimes give such terrible emphasis as to make us tremble at the performance of the "Dead March in Saul;" and it is also the same source which enraptures us with grateful assurance when we listen to the grand production of Haydn in his most beautiful anthem, "As pants the hart for cooling streams," and it is surprising to find how near to perfection are some of the instruments produced by this

firm. The same high commendation may be given for transposition of music; it is as correct as possible.

Time and space would fail me were I to attempt even to enumerate the volumes of music to be found in their library; it must suffice to state it contains the principal productions, sacred and secular, of the greatest masters of ancient and modern times. Here you will not only find the collection of Pope Gregory I., which it is well known contains the very tunes which Jesus sang, but you will also find the most recent air that is sung at the missionary meetings of Moody and Sankey. I was surprised to learn that no less than 6,000 pieces are in stock to select from.

In making a key-board, or comb, as it is sometimes called, no expense is spared by the proprietor in procuring the very best metal that can be obtained, and which experience has proved to be most suited for the purpose. It is that which is known as mild cast steel or spring steel. It is not so highly carbonized as that which is used for gravers and cutters. The workman no sooner takes the rough piece of metal in hand than he commences to examine it most carefully to see if there is any flaw or imperfection in it. The tests applied are such as these: First, the tensile strength is examined; if it shows a tendency to elongate and then return, as it were elastic, it is a good sign; a small piece of the metal is then broken of; if it shows signs of toughness and has to be bent backwards and forwards several times before it gives way, this is also a good sign; but if it should break easily it is at once rejected. The broken surfaces are then examined microscopically, and flaws in the metal, if any, are then easily detected. If on the broken surfaces large bright crystals appear, after showing but little strength in breaking, the metal is undoubtedly bad. The sound of the metal and continuation of the note is also a test. The workmen possess great skill in these preliminary operations. The pieces of metal are cut from the large sheets by shears, and always so cut that the teeth of the comb can be cut in the direction of the grain, *i. e.*, the direction in which the metal is rolled. It is then planished and annealed, being made red hot—a dark red, not white heat—and covered up in plenty of saw-dust so that no air can get to it, and allowed to cool gradually. The teeth are cut with great rapidity and exactness in an elaborate dividing engine worked by steam power. In the tuning of the key-board it is sometimes found, notwithstanding the care in the commencement, that one or two of the keys will show feebleness, and want power and volume of utterance; these keys are taken out and new ones replaced by the following process: A key is made the same shape and temper as the defective one, but on the under part a foot is formed. A slot is then filed out of the steel block of the key-board the exact size of the foot. The new key is then gently hammered into its place, care being taken in this operation to fix it in a line with the other keys. It is then soldered in its place with the ordinary soft solder and soldering spirits used by tinmen. In this operation it is necessary to use a very large soldering copper bit, weighing about seven or eight pounds; a smaller one will not retain sufficient heat to penetrate the key-board. When the key is well fixed, it is filed up perfectly level with the others, and tuned by filing it underneath. If it has been executed by a good workman no one can detect it. A premium is put upon workmen who show great cleverness in this kind of work, as they are generally drafted away to the London or New York depots for repairs, an extensive business of this kind being carried on at each of these houses in difficult repairs that the proprietors would be glad to get rid of, and they contemplate publishing an exhaustive treatise on this subject for the use of their customers.

---

#### Our Providence Letter.

[FROM OUR SPECIAL CORRESPONDENT.]

“WHAT is the prospect for the spring trade?” This is the query propounded by nearly every manufacturer one meets, and is about as knotty a question as could well be put.



There seems to be a somewhat better and more hopeful feeling springing up, and while the January buyers will probably limit their purchases to sample lines, it is likely that toward the end of February there will be some demand for goods, and that trade will steadily improve. I base this opinion upon reports upon other branches of trade from the South, West and North-West States. I had a long conversation with one of the largest cotton manufacturers in this State a few days ago. Speaking of mills shutting down, he said: "Although this may at the first glance appear a very disheartening feature, it is really a good thing. We are getting our stocks rapidly reduced, and in January will start in on full time with plenty of orders ahead. This renewed activity will cause a feeling of confidence all round, and will, I hope, produce a boom in business generally. It is much better to shut down altogether than to run along on half-time with half the usual number of hands. You may rest assured," said he in conclusion, "that the fall of 1885 will prove a pretty busy one for our manufacturers." The Jewelers' Board of Trade have elected Mr. George H. Slade for Secretary, at the liberal remuneration of \$750 per annum. Mr. Slade has not heretofore been connected with the jewelry business, but was employed in a hat store. A waggish manufacturer suggested that he was elected to the position on account of the *affinity* between the trades. Be this as it may, the action of the Board of Directors in the matter has been severely criticised. Parties who had signed the constitution are not inclined to pay their dues, and altogether the outlook of the Board is not very encouraging. In two recent failures, Simons & Wolff of Philadelphia, and M. Strouss of Chicago, members of the Board of Directors were sent out to investigate and take what action was necessary to protect the interest of creditors. In the former case Mr. McKinney succeeded in getting a stay of sale, but in the latter nothing has so far been accomplished. The stay of sale in the first instance will not, I think, be of the slightest benefit to the creditors, as the State laws of Pennsylvania present some peculiar features in this respect. The manufacturers are taxing their ingenuity to the utmost in getting up new designs for the spring trade. Ellison & Vester bid fair to head the list in the way of novelties. They have made up a very handsome line of mourning goods, the black being both in bright and dull colors. The process by which this result is achieved is said to be entirely new. William Butt & Co. have brought out a new patent lever button, and have, in addition, a line of lace pins in augmentation of their old staple line of bracelets. Mr. Charles F. Irons, whose premises were recently injured by fire, has rebuilt and refitted the whole of the upper story of his factory building, and has now one of the most convenient and best lighted workshops in this city. It may be said of him as of the fabled Phoenix, that he rises with renewed vigor from his own ashes. C. S. Pine & Co. have bought out the patent, tools, stock, etc., from the receiver for Lester & Chadwick, and will continue the manufacture of their bracelet. John McCloy is bringing out quite an extensive line of new goods. Mr. Charles Downs has got up a handsome medallion in honor of the New Orleans Exposition. On the one side is Commerce illuminating the world, and on the other the arms of New Orleans and Louisiana. C. Foster & Co. are also getting up an entirely new line of goods that are likely to have a ready sale. The usual monthly meeting of the New England Manufacturing Jewelers' Association was held at their rooms on the 6th inst. Mr. A. Potter, the President of the Association, was in the chair. The minutes of the previous meeting and the Treasurer's report were read and approved. Mr. Carpenter, the Secretary of the Music Committee, read a long and able report. At the conclusion of which he was, on the motion of the President, tendered a hearty vote of thanks. There was no new business before the meeting. A circular asking the manufacturers to sell only to legitimate jobbers, and signed by a large number of the wholesale houses throughout the country, has attracted considerable attention, and it will, perhaps, be well for the members of the Board of Trade to consider how far they were justified in allowing one of their number, at a recent meeting,

to state that he, in common with the greater portion of the Eastern manufacturers, sold all the retail trade he could, and on a motion made by him as to information to be given to customers, alter the term wholesale dealers, as originally set out in the by-laws, to dealers in jewelry. While the manufacturers undoubtedly have their grievances, it must in justice be confessed that the jobbers have theirs also, and their action in issuing this circular shows a friendly feeling and a disposition to do what is right and fair.  
Providence, R. I., December 17, 1884. ASMODEUS.

### The Jewelers' League.

*President*, GILBERT T. WOGLOM.....Of Woglom & Miller.  
*First Vice-President*, WM. C. KIMBALL.....Of H. F. Barrows & Co.  
*Second Vice-President*, AUG. KURTZBORN..Of L. Bauman Jewelry Co. St. Louis, Mo.  
*Third Vice-President*, JAMES P. SNOW.....Of G. & S. Owen & Co.  
*Fourth Vice-President*, HENRY HAYES.....Of Wheeler, Parsons & Hayes.  
*Secretary and Treasurer*, WILLIAM L. SEXTON.....Of Sexton & Cole.

#### EXECUTIVE COMMITTEE.

ROBERT A. JOHNSON, *Chairman*.....Of Colby & Johnson.  
SAMUEL W. SAXTON.....Of Saxton, Smith & Co.  
CLEMENT B. BISHOP.....Of Carrow, Bishop & Co.  
JOSEPH B. BOWDEN.....Of J. B. Bowden & Co.  
GEORGE R. HOWE.....Of Carter, Sloan & Co.  
CHARLES G. LEWIS.....Of Randel, Baremore & Billings.

THE JEWELERS' CIRCULAR is the *exclusive* official paper of the Jewelers' League, and has been selected for the publication of all matters of interest pertaining thereto. Letters or inquiries pertinent to its business or purposes, and which might interest the trade or inquirers, will herein be answered. Address *Jewelers' League, Box 3,444, P. O., New York*, or the office of THE CIRCULAR.

At the meeting of the Executive Committee held on Dec. 5th, there were present President Woglom, Vice-Presidents Kimball and Snow, Messrs. Johnson, Lewis, Howe, Bowden and Sexton.

Seven (7) changes of beneficiaries were granted.

Three (3) applications referred for investigation.

The following 12 applicants were admitted:

A. Dizerens, L. Stern, R. Sneider, N. Y. City; J. K. Stoddart, Philadelphia, Pa.; P. Geritz, Freeland, Pa.; G. E. Knapp, Boston, Mass.; C. A. Church, Amboy, Ill.; J. W. Good, Springfield, Ill.; J. M. Howe, Hopkinsville, Ky.; F. Trayer, New Orleans, La.; J. A. Montgomery, Los Angeles, Cal.; R. Beeston, London, Eng.

Notices of proposed amendments were received as follows:

By J. F. Minaldi: "To form a half-rate membership, with death benefit not to exceed \$2,500 and death assessment of one dollar."

Another member: "That all proposed amendments to Constitution be published and sent to each member not less than 15 days before the Annual Meeting.

The Secretary was authorized to hire Masonic Hall, cor. 23d St. and 6th Ave., for the Annual Meeting of the League, to be held on Tuesday evening, January 20th, 1885.

## Recent Patents.

The following list of patents relating to the jewelry interests, granted during the past month, is specially reported by FRANKLIN H. HOUGH, Solicitor of American and Foreign Patents, 617 Seventh Street, N. W., Washington, D. C.

*Issue of November 11th, 1884.*

No. 307,833—Chain-hook, Ornamental. C. F. Beyerle, Providence, R. I.

No. 307,869—Finger Ring. A. B. Place and J. B. Peterson, Providence, R. I.

No. 307,968—Watch Case. J. Macher, New York, N. Y.

No. 307,925—Watch Stop. E. J. A. Dupuis, assignor to P. A. Raymond, New York, N. Y.

*Issue of November 18th.*

No. 308,096—Watch, Mainspring Winder. A. F. Robbins, Orange, Mass.

No. 308,320—Watch Spring Holder. C. H. Morgan, E. J. Watson and H. W. Wilson, assignors to Washburn & Moen Manufacturing Company, Worcester, Mass.

*Issue of November 25th.*

No. 308,504—Jewelry, Ornamenting. C. J. Leyers, Newark, N. J.

No. 308,445—Watch Case Spring. C. W. Thiery, Boston, Mass.

No. 308,448—Watch Regulator. G. I. Tuttle, Aurora, Ill.

No. 308,489—Watch, Stem Winding and Setting Mechanism. H. M. Haines, Waltham, Mass.

*Issue of December 2d.*

No. 308,840—Watch, Dust Proof Box and Case combined. C. K. Giles, Chicago, Ill.

*Issue of December 9th.*

No. 309,018—Watch, Bow Fastening. B. A. Barnes, Oelwein, Iowa.

No. 309,158—Watch Case. D. O'Hara, Waltham, Mass.

---

### Cost of Obtaining Foreign Patents.

THE FOLLOWING information, supplied by Munn & Co.'s Patent Office, New York, will be of much interest to inventors desiring patents:

**GERMANY.**—The new Patent law, covering Prussia and all the German States, was put in operation July 1st, 1877. It was formerly necessary to take some twenty-one separate patents, costing several hundred dollars, to cover the same territory which is now protected by a single patent. A patent may be taken for one year or any other number up to fifteen years, by the payment of taxes annually, which are progressive in amount. Must be worked within three years. A patent may be claimed by the first applicant, but if the essential parts of the invention are taken from models or drawings of another person without the latter's consent, the former has no claim to the patent.

Inventions are examined and may be rejected for lack of novelty, or from having been introduced into the Realm before application for a patent was made. An appeal may be taken from the Examiner's decision to another tribunal, similar to the appeal provisions in the United States. Patents for additions, or improvements on inventions already patented, may be had.

The expense for a patent and first year's tax for a simple invention is \$100; when requiring elaborate drawings and a lengthy specification, a small sum in addition.

Patents cannot be obtained in Germany for inventions that have been previously patented in the United States. Therefore the application for the German patent should be made before the U. S. patent is actually issued.

**ITALY.**—The expense to apply for an Italian patent is \$100, which includes all fees for the first year. The patent is granted for fifteen years, subject to a small annual tax. Working must take place within one year. Italy covers a large extent of territory, has an enterprising population of twenty-seven millions, and is making rapid industrial progress.

**AUSTRIA.**—The expense to apply for a patent in Austria is one hundred dollars (\$100), which includes agency, government taxes and all costs for first year. The patent is granted for fifteen years, subject to a small annual tax. The invention must be worked within one year. The Austrian patent covers also Hungary, and includes a total population of forty millions.

**RUSSIA.**—Duration of patent, three, five or ten years. The terms cannot be extended. The invention must be worked in the empire during the first quarter of the period for which the patent has been granted. No annual taxes. The expense to apply is as follows:

|              |       |
|--------------|-------|
| 3 years..... | \$200 |
| 5 " .....    | 250   |
| 10 " .....   | 500   |

**BRAZIL.**—Under the new law recently passed, foreigners can obtain patents in Brazil on very favorable terms. The application must be filed within seven months from the date of the foreign patent. The patent is granted for fifteen years, subject to a small annual tax. Working must take place within three years from the date of the patent. The expense to apply for the patent is \$250, which includes our charges. The law opens a fine field for American inventions.

**TRADE-MARKS.**—Security for trade-marks can be secured by citizens of the United States in the following countries, at the prices annexed, which include both the government and agency fees: Canada, \$50; Great Britain, \$75; Belgium, \$75; France, \$75; Austria, \$75; Switzerland, \$75; Germany, \$100; and in nearly all other countries at same rates.

---

### Swiss Watches for the American Market.

THE DECLARED exports from the consular district of Basle during the fiscal year ending June 30, 1884, show that there has been a net decrease of \$470,612.72, or nearly 15 per cent., as compared with the preceding year. This decrease is chiefly attributable to the diminished exportation of watches and watch materials from the consular agency of Chaux de Fonds, which was \$500,000 less than during the preceding year. That this branch of exportation will continue to decline in consequence of the rapid development of the corresponding industry in the United States, until it ceases altogether, cannot be assumed with entire confidence. As is well known, the Swiss have once recovered their lost ground in this direction. Having seen their American market almost escape them after the Centennial Exhibition in 1876, they were able by the employment of the greatest energy, perseverance and skill to regain what they had lost, and even to increase their export of watches to a point never before reached. In 1882 the amount was \$2,268,731.79 from that district alone.

"This point," says Consul Gifford, "may never be reached again, but the Swiss will not surrender their American market without a renewed struggle. They will in this be seconded by many circumstances which are favorable to their supremacy in this branch of production. The principal advantage is the low rate of wages which must be accepted by men occupying the sterile valleys of the Jura, where agriculture is impossible, and where they have been from their childhood devoted to this one calling. They must make watches, if not for good wages, then for poor wages. It might be supposed that only the higher priced merchandise and timepieces of special construction and extraordinary precision could now find a sale in the United States, considering the immense numbers of low-priced articles produced by our manufacturers. But such is not the case. Very large shipments of so-called watches, invoiced as low as 10 francs each, and even lower, still go forward. A suspicion of gross undervaluation naturally arose under these circumstances; but a personal investigation and examination of the books and original accounts of manufacturers led to the conclusion that watches can be, and are, produced at these seemingly impossible prices. The declared exports also show a decline in the exportation of cheese and aniline colors to the United States during the fiscal year. This decline and the comparatively small increase in the value of the silk ribbons exported are probably to be regarded rather as incidental variations than as indications of a permanent tendency."

## Foreign Gossip.

**DEATH.**—The death is announced of M. Bourdon, the inventor of the metallic manometers, barometers and gauges that bear his name.

**PRECAUTIONS.**—A French paper affirms that the zealous officials of "El reg, Don Alfonso," fumigated a quantity of chloride of lime at the border quarantine station, Irun, according to rules laid down and provided, to keep out that naughty cholera.

**HONORS.**—The *Impartial* says that the committee of the horological school of Locle is soliciting donations from the inhabitants of the city and vicinity, for the purpose of erecting a monument to the lately deceased DANIEL HANS RICHARD, and that they are quite successful in their endeavors.

**STEADY INCREASE IN AUSTRALIAN GOLD DIGGING.**—Mr. G. W. Langtree, Acting Secretary for Mines in Victoria, reports the estimated quantity of gold raised in the quarter ending June 30, as 190,218 ounces, 3 pennyweights; and he gives the number of miners employed on the gold fields during that quarter as 29,075.

**EXPOSITION OF NUREMBERG.**—The exposition of goldsmiths' and jewelry work at Nuremberg promises to be a grand affair; all the art collections of Europe have promised to send their choicest treasures—of course, as loans—and it would well repay the trouble if some of our large manufacturers were to send their designers there to study these *chefs d'auvres* of past ages.

**EFFECTS OF DIFFERENT KINDS OF ILLUMINATIONS.**—The tallow candle is the most unhealthy kind of illumination, while the electric light is the best. The latter produces only one-thirteenth part of the heat generated by a tallow candle and emits no carbonic acid or water. One gas flame is said to vitiate the air of a room as much as six persons do with their corporeal exhalation and breath.

**TOPAZES.**—A remarkable discovery of topazes was made lately in New South Wales. A portion of a large, bluish-green crystal, of the weight of several pounds, was found in Mudjee and sent to the Colonial Museum. Several crystals of 2 to 3 inches were found in Uralia. One specimen of topaz, found in Gundagai, weighed more than 11 ounces, and another one, found in Gulgong, weighs 18 ounces.

**AUSTRALIAN GOLD DIGGINGS.**—Very little is heard at present of the Australian gold diggings, nevertheless there were in March, 1884, in Victoria, 30,474 diggers who made their living exclusively by gold digging. The gold dug in that country in the first quarter of this year was computed to be 181,011 ounces—which is considered a very fair yield. The districts of Sandhurst and Ballarat furnished the largest quantities—each one about 50,000 ounces.

**THE INTERNATIONAL POSTAL UNION.**—The *Union Postale*, the organ of the international bureau in Berne, Switzerland, says that on the 9th day of October last, ten years ago, the several representatives of the postal departments of Europe, the United States of America and Egypt, met in the Old Court house and established the first international postal union. It convened at the instigation of Germany, and before the end of a month the world saw an enterprise completed, the accomplishment of which had been doubted even by the majority of the most enthusiastic members. Great credit is due to the several representatives for their unanimity; the occasion, indeed, well permits us to become enthusiastic, because such a union stands sole of its kind in the history of nations, and so broadly is conceived the foundation of this international structure, that its roof will shelter all the civilized nations of the earth, while the possibility that even the greatest political revolutions can ever affect it appears to be entirely excluded. It is indeed an eternal monument erected to the glory of its constructors, and all those who in any manner participated in its establishment.

**GERMAN PEARL FISHERIES.**—The German pearl fisheries of Saxony and Bohemia, which were formerly very remunerative, are barely worth mentioning at present, as they are rapidly destroyed both by the natural cupidity of man and the filthiness of the streams. The department of the interior lately called the attention of the officials charged with the preservation of these grounds to existing laws, and exacts of them to energetically oppose the wholesale destruction.

**STANDARD MERIDIAN.**—It is rather to be deplored that the international conference for establishing the prime standard meridian has adjourned without coming to any agreement. The meridian of Greenwich being almost universally used in the civilized world, and the basis of nearly all the meridional calculations was proposed, but the French representation "kicked" against it, and, therefore, no satisfactory results were obtained. The world could not well get along without a body of scientific men, but it is rather sad to contemplate that each one of them has some pet theory of his own which he cherishes with all the love and devotion bestowed on a "hobby." When a lot of business men met in 1874 at Berne, and established the international postal union, the grandest piece of international fraternity, they transacted their business in a business-like manner; not so a body of savans, however; each one of them has some hypothetical theory, upon the recognition of which by all he bases his glory everlasting, and hence the difficulty of uniting them to act in harmony.

**THE HYDRAULIC CLOCK IN THE GARDEN OF THE TUILERIES.**—The visitors of the garden of the Tuileries lately pause before a timepiece of extraordinary dimensions, which has been erected upon a terrace at the water's edge. It consists of four columns, painted green, about 8½ yards high, while the dial, glittering in the tricolors of the "Grande Republic," surmounts the columns. The large hand, about 2 meters long, points out the date, while the small hand indicates the day of the week. Beside this the clock contains a smaller dial with hour and minute hands; the striking work tolls the hour on a bronze bell. The action of this "chronometric turbine" is as follows: At the foot is located a metallic drum through which runs a streamlet of water. The drum contains two small turbine wheels which are actuated by the running of the stream. The axes of the turbines, prolonged upward, end in endless screws by which the wheel work, provided with a fly, is propelled. It is obvious that the reservoir from which this stream of water is obtained must always stand at the same level, otherwise the hydraulic pressure would change.

**EXPOSITIONS WITHOUT END.**—In a preceding number of THE JEWELERS' CIRCULAR we called our age the age of expositions, and we were then only half informed of the various expositions going on at the time, and Europe is eminently the country in which these expositions are held. A bi-monthly journal, devoted to the subject of expositions, publishes in its "Contents" the following summary: International World's Exposition of London, 1884.—International Arboricultural Exposition at Edinburgh, 1884.—Industrial Exposition at Teplitz (Bohemia), July to September, 1884.—International Exposition of motors and technical machinery for small tradesmen at Vienna, from July to October, 1884.—Upper Austrian Industrial Exposition at Steyr, August to September, 1884.—International Exposition at Amsterdam, August to September, 1884.—Local Trades' Exposition at Murrhardt.—Electrical Exposition at Turin.—International Exposition of Works of the precious metals and alloys at Nuremberg, 1885.—World's Exposition at Antwerp, 1884.—Exposition of the French crown jewels at Paris.—Exposition of Oriental ceramics at Vienna, from August to November, 1884.—Summer Fruit Exhibition at Berlin, 1884.—German Dairy Exposition at Munich, October, 1884.—Technical, Industrial and Agricultural Exposition in Wels, September, 1884. This, we hope, is enough to satisfy the most fastidious.

## Workshop Notes.

**ENGRAVERS' CEMENT.**—Resin, 1 part; brick dust, 1 part; mix with heat.

**ENGRAVERS' BORDER WAX.**—Beeswax, 1 part; pitch, 2 parts; tallow, 1 part; mix.

**CEMENT FOR MARBLE.**—The following is a good recipe for preparing a cement that will unite marble, etc.: Melt together 8 parts resin and 1 part of wax, and mix the solution with 4 parts of Paris plaster.

**GERMAN SILVER.**—An excellent German silver is prepared by smelting in a crucible 55 parts copper, 23 nickel, 17 zinc, 3 iron and 2 tin. This composition is in every respect equal to silver in appearance, fully as hard and not as vitreous.

**LIQUID FOR CLEANING SILVER.**—The following solution will be found to produce a high brilliancy in silver work: Cream of tartar, 30 parts; sea salt, 30 parts; sulphate of alumina and potash, each 39 parts; water, 1,500 parts. Boil the article in this mixture.

**CLEANING SILVER FILIGREE WORK.**—Anneal your work over a Bunsen flame or with a blowpipe, then let go cold (and this is the secret of success), and then put in a pickle of sulphuric acid and water, not more than five drops to one ounce of water, and let your work remain in it for one hour. If not to satisfaction, repeat the process. This is undoubtedly the best process that can be used.

**ENAMELING ON BRASS AND GERMAN SILVER.**—The adhesion of enamel to brass and German silver, it is said, may be most perfectly effected by first engraving or pressing the design to be enameled into the alloy, and then coating the whole object, or only the depressed design, galvanically with copper. The enamel can be fused upon this surface as usual, and may then be bronzed, or silvered, or treated in any usual way.

**CHARCOAL.**—The charcoal used in soldering, nor, in fact, any other charcoal used by the goldsmiths, should not possess the evil habit of viciously snapping and cracking. Coal burned from oak, or any other coarse-grained wood, will snap and crack, while a close, fine-grained, soft wood coal will not. The underlay coal may have its snap taken out by being heated very hot in an oven or by blowing the flame with a blowpipe upon it.

**MIRROR-LIKE DESIGNS ON GLASS.**—An ingenious method of obtaining mirror-like designs on glass has been devised by Leclerc. The glass, having been silvered by the chemical process, is coated with a thin and uniform layer of sensitive bitumen, and this is exposed under a transparency, the next step being to wash away the unaltered bitumen with oil of turpentine, so as to leave the bitumen design on the silvered glass. The application of moderately strong nitric acid removes the silver, excepting where it has been protected by the bitumen, so that the metallic design shows like a mirror from the reverse side of the glass. The plate may be backed by paint or any other suitable material.

**COLORING METAL.**—Metalic objects may be colored by immersing them in a bath formed of 640 grains of lead acetate, dissolved in 3,450 grains of water, and warmed to from 38° to 90° Fahrenheit. This mixture gives a precipitate of lead in black flakes, and when the object is plunged into the bath the precipitate deposits on it. The color given depends on the thickness of the skin, and care should be taken to treat the object gradually, so as to get a uniform tint. Iron treated thus acquires a blueish aspect like steel; zinc, on the other hand, becomes brown. On using an equal quantity of sulphuric acid, instead of lead acetate, and warming a little more than in the first case, common bronze may be colored red or green, with a very durable skin. Imitations of marble are obtained by covering bronze objects warmed to 100° Fahrenheit, with a solution of lead, thickened with gum tragacanth, and afterwards submitting them to the action of the above mentioned precipitate of lead.

**TO SOLDER A STAY SPRING.**—Stay or lifting springs are often broken, and the watchmaker has frequently none of the right size nor the time to make a new one. In such a predicament he can mend the old one and have it just as good as new, by placing the broken parts together and binding them firmly to a piece of coal, then soldering them with 18-karat gold. It requires a strong heat and plenty of borax; then finish off, nicely harden and temper in the usual manner.

**TO CLEAN A MAINSPRING.**—The botch can never be recognized so quickly in the workshop as by the way he has for cleaning a mainspring. He will take hold of one end and pull the spring about half its length through a greasy rag, with a quick and jerky motion, to save time. This practice is calculated to break springs when nothing else will; and those treated in this manner will invariably break in a few days after, from the very fact that their molecularly was violently destroyed. Never draw the spring out of its coils; if it requires cleaning, lay it flat in your hand, then with a soft oiled rag wrapped around a pegwood, follow through all the intricacies of the coils, reverse the spring, and treat the other side in the same manner, and our word for it, the spring will not break, to the great aggravation of the watch owner.

**RAPID SILVERING.**—The watchmaker is occasionally called on to resilver old clock faces or other parts belonging to clocks. When the article is not exposed to handling the following recipe for silvering will be found to be very efficacious: Get one-quarter ounce of nitrate of silver, to be had at every drug store, dissolve in a teaspoonful of water, and then add one-quarter pound of cream of tartar and three-quarter pound of common table salt; thoroughly mix these ingredients together with a wooden stick, adding sufficient water to make a thick paste. Put this by in a glass-stoppered bottle for use as required, and it will keep any length of time. This is the silvering powder, and before applying it to the brass, this must be made quite clean and bright. Get a piece of chamois leather, and fold it up small enough to be handy; with this rub on the silver paste thoroughly all over, till by the appearance of the brass work you judge the silvering to be properly effected. Now wash the article quite clean, finally polishing off with a little whiting; this will finish, as far as the silvering process is concerned; but to make the coating last under atmospheric influences, it must be protected by a coat of varnish. Any colorless varnish will answer for this, which can be procured anywhere. Of course the more silver powder is rubbed on the thicker the coating, and it will stand good for years.

**ISOCRONISM.**—It will have happened to the repairer and adjuster that when a ruined or badly mounted balance and spring was straightened and set in order by him, the rate of the watch differed materially, and the spring had to be reset; a proof that a spring of equal length and thickness, but of another curve, requires another adjusting; the power of resistance or tension of the spring is virtually altered. Generally when a watch retards it is presumed that its spring is too weak, or, what is the same, too long, and every watchmaker knows that by further drawing through the spiral stud its vibrations are accelerated. The cause of the acceleration, however, does not lie in the immediate shortening and approach of its two ends, but in the alteration of its curves, whereby the proportion of the curve dimensions to the length, and thereby to the weight of the balance, becomes another, and favors a greater power of resistance. If the proportion of length alone were to decide, then the same quantity of shortening of the balance spring would produce the same effect, which, as everyone knows, is not so. By shortening the spring on its inner end, its power of resistance is sensibly augmented, because the operating power of the balance upon the spring is lessened by the change from the center of the inner curve. For this self-same reason the inner curve should be treated with all possible consideration.

## Trade Gossip.

The firm of Theuerner & Church, manufacturers of gold rings, was dissolved by mutual consent December 13. Mr. C. F. Church will continue the business.

A. J. Paillard, of the firm of M. J. Paillard & Co., who recently returned from Europe, has since been dangerously ill with pneumonia, but is now convalescent.

We are pleased to see that our friends, the Spencers, are making a success with their instrument for measuring the eye. This firm is entitled to credit for their efforts to bring optics up to a high standard.

The American Watch Company at Waltham has reduced the rent of the houses occupied by their workmen from 20 to 25 per cent. At the same time, the price of board at the boarding-houses controlled by the company has been materially reduced.

The American Watch Tool Company, of Waltham, was robbed by burglars on the night of Dec. 6, and a lot of tools, lathes, etc., were carried off. A description of the stolen property will be found in the advertising columns of this issue of THE CIRCULAR.

The 14 karat gold filled watch case, manufactured by the Dueber Watch Case Company, of Cincinnati, has met with much favor in the trade, and the company has had difficulty in keeping up with the demand. Those desiring them should place their orders promptly.

R. Henrich, manufacturer of seal and stone rings, has introduced this season a new line of ladies' rings in fanciful patterns, embracing turquoise, cat's-eyes, garnet, etc.; also new designs in self-sizing rings. Their initial rings include a great variety of styles and fancy designs.

The season of calendars is upon us, and we have received several of very handsome design from members of the trade. Among these are the tasteful ones issued by Foster & Bailey and William T. Smith. They are printed in subdued colors, and are very attractive without being gaudy.

The second thimble centenary has just been celebrated at Amsterdam. The first thimble was made in October, 1684, by a goldsmith, Van Benscholten, whose idea in the manufacture of the pretty conceit was to protect the fingers of his lady-love. The English were the first to adopt the new invention.

Koch & Dreyfus, of New Orleans, have issued a handsomely printed circular to the trade, announcing that they will take pleasure in securing suitable accommodation for such as contemplate visiting the Industrial Exposition, and extending any courtesies in their power. Their circular contains full statistical statements regarding the Exposition buildings, etc.

Mr. Clement L. Wragge has started a meteorological station on the summit of Mount Lofty, in connection with his Torrens Observatory at Sydney. He has placed self-registering instruments and a rain-gauge of an improved pattern on the summit, and appeals to the public who may visit the mountain to protect them, and so assist in promoting scientific research.

Hutchison & Huestis send out with this number of THE CIRCULAR an elegant New Year's Greeting to the trade, in the form of a lithographic page which cannot fail to catch the eye of every reader. This firm has acquired an enviable reputation for the manufacture of solid gold stone rings of every variety and style. They sell to jobbers exclusively, and their goods may be found everywhere.

As an indication of confidence in the business outlook, all the cotton factories at Augusta, Ga., have advanced the price of goods one-quarter of a cent per yard, and all the mills there are running on full time. The extensive carpet works of Alexander Smith's Sons, at Yonkers, N. Y., employing 2,000 hands, will soon start up. The cotton mills at Fall River, Biddeford, Lewiston and other localities are also about resuming operations.

In these days of many accidents every person should provide himself with an accident insurance policy. The United States Mutual Accident Company is conducted on the mutual plan, assessment being made on the members to pay liabilities. It costs only \$10 or \$12 a year to carry a policy insuring \$5,000 in case of death by accident, or \$25 indemnity in case of injury. This company has a surplus of \$30,000, and is strongly commended by prominent business men and by thousands to whom it has paid benefits.

Several of the daily papers recently stated that James Greeves, who was arrested for smuggling diamonds, was a member of the firm of John Bowden. There is but one firm in the city engaged in the jewelry business of that name, and that is J. B. Bowden & Co., the well known manufacturers of solid gold rings, at No. 1 Maiden Lane. Mr. Greeves was never a member of this firm nor in any way connected with it. The statement as published was calculated to do injustice to J. B. Bowden & Co., but the papers that printed it with so much alacrity, were extremely niggardly in making the desired correction.

The trade will be well represented at the World's Industrial Exposition at New Orleans. Owing to delay in getting goods into position, it is impossible at the time of our going to press to obtain a proper notice of the exhibits, but we hope to do so in our issue for next month. Among the exhibitors are the American Watch Company, the Meriden Britannia Company and various other large manufacturers. Leroy W. Fairchild, manufacturer of gold pens, pencils and fancy goods, has a full line of his products which have been arranged in a unique and attractive form. These goods will, no doubt, command much attention at the Exposition, as they are exceedingly popular in the trade.

Daring burglars robbed the store of Napoleon Lefebvre, which is just opposite the Central Police Station, in Montreal, on the night of Dec. 17. They gained an entrance through the fanlight, drilled the safe, smashed the combination lock and blasted their way to the inner strong box. They succeeded in walking away with \$10,000 of precious stones and jewelry, and \$8,000 in promissory notes. The stock in the show cases and elsewhere had been thoroughly overhauled by the thieves. The thieves are suspected to be a New York crowd that has been noticed here of late. This is the tenth or eleventh robbery that has occurred in as many weeks, and the worthlessness of policemen and detectives is spreading dismay among storekeepers.

Maier & Delkin, of Atlanta, Ga., were recently victimized by an adroit swindler. He offered some gold foil for sale, representing it to be the waste of china gilders. They assayed it, and finding it good offered \$70 for the lot. The man said he was not authorized to sell it for less than \$75, and, putting it in his pocket, was apparently about to depart, an offer of \$75 was made which he accepted, handed out the foil and departed with the cash. Subsequent examination showed that he had dexterously substituted a package of lead for the package of gold. They were made up alike and weighed precisely the same, but as the firm was busy, the package was not tested the second time it was presented. The trade is warned against this trick of the enemy.

With the first of the year, the T. A. Willson Optical Company, of which Gustave Walter is president, succeeded to the business of T. A. Willson & Co., of Reading, Pa., the celebrated makers of optical goods. Their offices are located at No. 14 and 16 Maiden Lane, and hereafter all goods will pass through the New York office. The company has added increased facilities to the formerly large factory of T. A. Willson, and will hereafter be able to fill all orders promptly and deal liberally with the trade. Mr. Walter is well and favorably known in the trade as an active, enterprising business man, while the T. A. Willson goods have achieved a wide celebrity. These consist of gold, silver, steel, nickel and nickel plated spectacles and eye-glasses, watch glasses, opera glasses, pebble and spectacle lenses, ground and unground, in fact, everything in the line of optical goods.

It has been known for some time that imitation American watches were being sold in Europe, in South America and some of the British Colonies. Messrs. Robbins & Appleton determined to ferret the matter out, and finally their agent succeeded in buying a gold and a silver watch from a Paris house. Legal proceedings were begun against the firm and judgment obtained. It was found that the watches were made in Switzerland, and bore the name of the American Watch Company, Waltham. In the issue of the *London Jeweler and Metal Worker*, Mr. Lewis Jacobs, "pawnbroker and jeweler, 102 Leather lane, Holborn Circus, E. C.," publishes an apology to the American Watch Company for having sold a bogus American watch "by inadvertence," and promises that he will not do so any more. The company is determined to break up this disreputable business if possible.

Mathey Bros. & Mathez have a full line of complicated watches, for which the demand in this country is constantly increasing. These include minute repeaters, which strike the hour, the quarter and the minute; five minute repeaters; split-second fly-back with minute indicator; minute chronographs; plain chronographs; calendar watches, which, in addition to making the time, show the phases of the moon, day of the week and month, and indicating leap year. They have, also, a watch in which all these special features are combined, constituting a most complicated and beautifully accurate example of horological skill and perfect workmanship. This firm also carries a full line of fine Swiss watches and ladies' watches in almost endless variety. Many of these are exquisitely ornamented with precious stones. They also exhibit a miniature clock, only two inches high, appropriately designated "Baby," which runs eight days and keeps excellent time. This firm is so well known in the trade that it needs no commendation at our hands.

Henry Boxhorn & Co., diamond dealers, of Paris, opened a branch office in this city some time ago, a son of the senior member of the firm having charge. As the business was not as profitable as anticipated, orders came to dispose of the stock. E. du Moulin, a friend of young Boxhorn, offered to assist him in disposing of the diamonds. He took a number on memorandum, and represented that he had disposed of them to certain commercial gentlemen who would pay for them in the regular course of business. In this way he is alleged to have secured about \$15,000 worth of diamonds, most of which he pawned and then departed for Canada. Lawyers traced him across the border, but could obtain no better offer than a settlement on the basis of 25 cents on the dollar. Some of the diamonds were recovered from the pawnshops, valued, it is said, at \$10,000. The lawyers employed in the case undertook to collect a bill of about \$2,000 from young Boxhorn, but when they overtook him in Chicago they found nothing to attach. It is supposed that he had what diamonds he had rescued safely deposited where neither thieves nor lawyers could reach them.

The general passenger and baggage agents of the Illinois Central, Minneapolis and St. Louis, St. Louis, Keokuk and Northwestern, Burlington, Rock Island, Kansas City, St. Joseph and Council Bluffs, Hannibal and St. Joe, Northwestern, Sioux City and Pacific, St. Paul, Omaha, Northern Pacific and Manitoba roads on the first of December issued the following notice to take effect at once: "The undersigned companies will not accept any responsibility whatever for the receiving, storage, checking or forwarding of sample trunks, cases or packages carried by jewelers or traveling agents for jewelry houses. From and after the date of this notice their agents will refuse to receive from jewelers or traveling agents for jewelry houses or other persons any sample trunk, case or package that they may know or have reason to believe contains jewelry or jewelers' samples, either for storage in their baggage room, for checking as baggage, or for transportation in the cars of these companies, nor will they take charge of such trunks, cases or packages in any manner whatever. Should such be tendered, they will state to persons making the tender that they cannot be accepted.

At the office of the New Haven Clock Company, in New Haven, there was recently shown a splendid clock just finished, designed for exhibition at the New Orleans Exposition. It was constructed specially with reference to exhibiting at the Exposition, and is probably the finest clock ever made in New England. It cost \$1,000. It stands nine and a half feet high. The case is built of the finest mahogany, with elegant decorative carvings, showing skillful handiwork, while the dial is of silver and gold finish. A door of beveled plate glass, with a light mahogany frame, opens to the dial, and a larger similar decorative door opens below to the weights. Beautifully finished Corinthian pillars flank the main body of the case, surmounted by elegantly carved architraves. The clock rests upon gilded ornamental pedals. The long pendulum beats seconds and the clock chimes the quarter hours either on a set of eight bells or on another known as the Westminster chimes, both sets being very musical and the effect most pleasing. For the first quarter four bells are struck, for the second eight, for the third twelve, the fourth sixteen, and the hour is announced upon a deep-sounding cathedral gong, musical yet solemn, as if the flight of time were a grave matter and no unconsidered trifle. The clock runs eight days and has attachments which shift the striking works to suit the varieties of bells.

James Smith, who speaks with an English accent, entered the jewelry store of Ferdinand Craft, at No. 427 Grand street, and asked to see some rings. A tray containing about seventy gold rings was set on the counter, and he placed two of them on his fingers. He then threw red pepper into Craft's face, and seizing the tray, attempted to carry it off. The proprietor grappled with him and the tray fell to the floor. The thief made an ineffectual effort to get out through a rear passage way. Two detectives soon arrived, and the thief was subdued after drawing a revolver and offering a stubborn resistance. At the Tombs, while the detectives were preparing affidavits against him, the prisoner put on an overcoat that was thrown over his arm, and then approached Officer Walsh at the wicket. He said that he was the complainant in a case of assault, and, pointing to a prisoner, said that he was the accused person. He expressed much surprise that the officer should doubt his word, and presented his card as an evidence of respectability. After consulting with the other officers the gatekeeper discovered that Smith was a prisoner on two charges. He was then placed at the bar, where he manifested much coolness, and said that he was perfectly justified in endeavoring to escape. He then pleaded guilty to charges of assault and attempted larceny. He was committed for trial in default of \$1,500 bail.

We have received complete advance sheets of the fourth annual report of Professor Leonard Waldo, Astronomer at the Observatory of Yale College. In our issue for December we published the large table showing the watch rating results for Class I. certificates, showing the observations made of thirty-nine different watches for forty-two days in five different positions and in the oven and the refrigerator. The complete report shows the observations made of watches receiving certificates in Classes II. and III. Professor Waldo doing excellent service in horology by the care and attention he is bestowing upon the watches submitted for rating. He says "There has been marked increase in the excellence of the movements submitted to our trials, which, so far as can be observed, is a direct result of the interest our work in this department has excited." In addition to the observations of clocks and watches, 6,390 thermometers were examined, 9 hydrometers and 2 barometers. Professor Waldo is endeavoring to establish in the bureau a clock of precision, as they are often required to give daily rates of timepieces when the weather is sometimes cloudy for several days in succession. To this end one of the clocks has been re-mounted in a heavy cast-iron case, and hung between two brick piers. Arrangements have been introduced in it for the control of the pressure and the chemical constitution of the enclosing medium in which the pendulum swings. The report will be found full of interest to makers of watches and students of the science of horology.

**INDEX TO**  
**VOLUME XV.**

*FEBRUARY.*

|   | PAGE. |
|---|-------|
| Abomination of Preferred Creditors, The.....                              | 1     |
| Adjustment of a Four-Jewel Cylinder Watch, Practical Treatise on the..... | 9     |
| African Diamonds, Production of.....                                      | 27    |
| American Gems and Precious Stones.....                                    | 8     |
| Among the Patents.....  | 27    |
| Ancient Art, Revival of.....  | 5     |
| Annual Meeting of the Jewelers' League, Seventh.....                      | 17    |
| Annual Proclamation, The.....   | 5     |
| Apprentice System, Decadence of the.....                                  | 2     |
| Art, Revival of Ancient.....  | 5     |
| Arts and Customs, The Cup—Its.....  | 5     |
| Association, The Chicago Jewelers'.....                                   | 27    |
| Business Changes.....   | 28    |
| Catalogue Nuisance, The.....  | 3     |
| Cause and Effect.....   | 3     |
| Changes, Business.....  | 28    |
| Chicago Jewelers' Association.....  | 27    |
| Compasses, Pocket.....  | 12    |
| Correspondents, Views of.....   | 24    |
| Crucibles, Recovering Silver from Cast Iron..                             | 28    |
| Creditors, The Abomination of Preferred.....                              | 1     |
| Cup, The—Its Arts and Customs.....  | 5     |
| Cylinder Watch, Practical Treatise on the Adjustment of a Four-Jewel..... | 7     |
| Decadence of the Apprentice System.....                                   | 2     |
| Detail, An Examination in.....  | 4     |
| Diamonds, Production of African.....                                      | 27    |
| Effect, Cause and.....  | 3     |
| Gems and Precious Stones, American.....                                   | 8     |
| Glashutte, The Horological School at.....                                 | 7     |
| Glass, Venetian.....  | 15    |
| Goldsmith, The.....   | 29    |
| Graduating Thermometers.....  | 13    |
| Hard Money is Made, How.....  | 14    |
| Horological School at Glashutte.....                                      | 7     |
| How Hard Money is Made.....   | 14    |
| Jewelers' League, Seventh Annual Meeting of the.....                      | 17    |
| Jewelers' League, The.....  | 20    |
| Jewelry.....  | 11    |
| Jewelers' Association, The Chicago.....                                   | 27    |
| League, The Jewelers'.....  | 20    |
| Letters to Watchmakers.....   | 25    |
| Meeting of the Jewelers' League, Seventh Annual.....                      | 17    |
| Money is Made, How Hard.....  | 14    |
| Nuisance, The Catalogue.....  | 3     |
| New York, Trade of.....   | 5     |
| Obituary, James B. Goldey.....  | 28    |
| Observation, Very True.....   | 4     |
| Old Silver Divested of Romance.....                                       | 14    |
| Patents, Among the.....   | 27    |
| Pocket Compasses.....   | 12    |
| Practical Treatise on the Adjustment of a Four-Jewel Cylinder Watch.....  | 9     |

|   | PAGE. |
|---|-------|
| Precious Stones, American Gems and.....                                   | 8     |
| Precious Stones, The Treatment and Working of.....                        | 15    |
| Preferred Creditors, The Abomination of.....                              | 1     |
| Proclamation, The Annual.....   | 5     |
| Production of African Diamonds.....                                       | 27    |
| Recovering Silver from Cast Iron Crucibles...                             | 28    |
| Revival of Ancient Art.....   | 5     |
| Romance, Old Silver Divested of.....                                      | 14    |
| School at Glashutte, The Horological.....                                 | 7     |
| Seventh Annual Meeting of the Jewelers' League.....                       | 17    |
| Sight.....  | 21    |
| Stones, American Gems and Precious.....                                   | 8     |
| Stones, The Treatment and Working of Precious.....                        | 16    |
| Tempus Edax Rerum.....  | 17    |
| Thermometers, Graduating.....   | 13    |
| Trade Gossip.....   | 31    |
| Trade of New York.....  | 5     |
| Treatise on the Adjustment of a Four-Jewel Cylinder Watch, Practical..... | 9     |
| Venetian Glass.....   | 15    |
| Very True Observation.....  | 4     |
| Views of Correspondents.....  | 24    |
| Watchmakers, Letters to.....  | 25    |
| Watch, Practical Treatise on the Adjustment of a Four-Jewel Cylinder..... | 9     |
| What is Going on in the World of Science...                               | 16    |
| Working of Precious Stones, The Treatment and.....                        | 15    |
| Workshop Notes.....   | 30    |
| World of Science, What is Going on in the...                              | 16    |

*MARCH.*

|   | PAGE. |
|---|-------|
| Adjustment of a Four-Jewel Cylinder Watch, Practical Treatise on the..... | 40    |
| Advice to Watchmakers' Apprentices.....                                   | 47    |
| American Gems and Precious Stones.....                                    | 42    |
| Arts and Customs, The Cup—Its.....  | 38    |
| Art Schools, Industrial.....  | 36    |
| Bangles, How to Make and Engrave Silver...                                | 47    |
| Bicycle Watch Movement, The New Electrical                                | 35    |
| Business Changes.....   | 62    |
| Buying Wedding Rings.....   | 47    |
| Changes, Business.....  | 62    |
| Clock Trains.....   | 52    |
| Club, Proceedings of the Horological.....                                 | 53    |
| Confidence Operator, A, in San Francisco...                               | 35    |
| Cup, The—Its Arts and Customs.....  | 38    |
| Cylinder Watch, Practical Treatise on the Adjustment of a Four-Jewel..... | 40    |
| Defects of the Duplex Escapement, A Few...                                | 51    |
| Deluge. The.....  | 58    |
| Detached Lever Escapement, Problems in the                                | 46    |
| Electrical Bicycle Watch Movement, The New                                | 35    |
| Electric Jewelry.....   | 39    |

|   | PAGE.  |
|---|--------|
| Electro Fire-Gilding and Silvering.....                                   | 50     |
| Engrave Silver Bangles, How to Make and...                                | 47     |
| Escapement, A Few Defects of the Duplex...                                | 51     |
| Escapement, Problems in the Detached Lever.                               | 46     |
| Fire-Gilding and Silvering, Electro.....                                  | 50     |
| Foreign Gossip.....   | 62     |
| Four-Jewel Cylinder Watch, Practical Treatise on the Adjustment of a..... | 40     |
| Fund Society, The Jewelers' Safety.....                                   | 61     |
| Gems and Precious Stones, American.....                                   | 42     |
| Gilding and Silvering, Electro Fire.....                                  | 50     |
| Goldsmith, The.....   | 44     |
| Gossip, Foreign.....  | 62     |
| Gossip, Trade.....  | 62, 64 |
| Graduating Marks on Glasses.....  | 51     |
| Horological Club, Proceedings of the.....                                 | 53     |
| Horological School.....   | 37     |
| How to Make and Engrave Silver Bangles...                                 | 47     |
| Industrial Art Schools.....   | 36     |
| Institute, Washington Branch, Naval.....                                  | 41     |
| Jewelers' League, The.....  | 37     |
| Jewelry Stores, Robberies of.....   | 36     |
| Jewelers' Safety Fund Society, The.....                                   | 61     |
| Lathes and Lathe Work.....  | 43     |
| League, The Jewelers'.....  | 37     |
| Letters to Watchmakers.....   | 55     |
| Make and Engrave Silver Bangles, How to...                                | 47     |
| Marks on Glasses, Graduating.....   | 51     |
| Microscopes.....  | 49     |
| Movement, The New Electrical Bicycle Watch                                | 35     |
| Naval Institute, Washington Branch.....                                   | 41     |
| Notes, Workshop.....  | 63     |
| Oils, A Word on Watch.....  | 60     |
| Patents and Pirates.....  | 33     |
| Peculiarities of Precious Stones.....                                     | 57     |
| Practical Treatise on the Adjustment of a Four-Jewel Cylinder Watch.....  | 40     |
| Precious Stones, American Gems and.....                                   | 42     |
| Problems in the Detached Lever Escapement.                                | 46     |
| Proceedings of the Horological Club.....                                  | 53     |
| Proxy, Voting by.....   | 34     |
| Rings, Buying Wedding.....  | 47     |
| Robberies of Jewelry Stores.....  | 36     |
| Safes, Unsafe.....  | 34     |
| Safety Fund Society, The Jewelers'.....                                   | 61     |
| School, Horological.....  | 37     |
| Schools, Industrial Art.....  | 36     |
| Sight.....  | 59     |
| Silver Bangles, How to Make and Engrave...                                | 47     |
| Silvering, Electro Fire-Gilding and.....                                  | 50     |
| Stones, American Gems and Precious.....                                   | 42     |
| Stores, Robberies of Jewelry.....   | 36     |
| Trade Gossip.....   | 62     |
| Trains, Clock.....  | 52     |
| Treatise on the Adjustment of a Four-Jewel Cylinder Watch, Practical..... | 40     |
| Unsafe Safes.....   | 34     |

# The Jewelers' Circular and Horological Review.

|   | PAGE. |
|---|-------|
| Voting by Proxy.....                        | 34    |
| Washington Branch, Naval Institute .....    | 41    |
| Watchmakers' Apprentices, Advice to.....    | 47    |
| Watchmakers, Letters to.....                | 55    |
| Watch Movement, The New Electrical Bicycle. | 35    |
| Watch Oils, A Word on.....                  | 60    |
| Wedding Rings, Buying.....                  | 47    |
| Workshop Notes .....                        | 63    |

## APRIL.

|  | PAGE.  |
|--|--------|
| Adjustment of a Four-Jewel Cylinder Watch,<br>Practical Treatise on the..... | 78     |
| Advice to Watchmakers' Apprentices.....                                      | 94     |
| Aristarchius Plumbago and his Bicycle Watch<br>Company.....                  | 69     |
| Arts and Customs, The Cup—Its.....   | 71     |
| Auction Plated Ware.....   | 67     |
| Auxiliary Compensation.....  | 85     |
| Bangles, How to Make and Engrave Silver...                                   | 89     |
| Barrel Arrangement for Clocks, A New.....                                    | 92     |
| Bric-à-Brac Collector, Whims of a.....                                       | 76     |
| Chicago Relief Fund, History of the.....                                     | 82     |
| Clocks, Electric.....  | 80     |
| Clock, A New Pendulum.....   | 77     |
| Club, Proceedings of the Horological.....                                    | 81     |
| Collector, Whims of a Bric-à-Brac.....                                       | 76     |
| Compensation, Auxiliary.....   | 85     |
| Correspondents, Views of .....   | 86     |
| Cup, The—Its Arts and Customs.....   | 71     |
| Detached Lever Escapement, Problems in the.                                  | 93     |
| Dial, A New Sun.....   | 78     |
| Diamond Fever, The.....  | 67     |
| Electric Clock.....  | 80     |
| Escapement, Problems in the Detached Lever.                                  | 93     |
| Fever, The Diamond.....  | 67     |
| Foreign Gossip.....  | 92     |
| Four-Jewel Cylinder Watch, Practical Treatise<br>on the Adjustment of a..... | 78     |
| Glasses, Size of Spectacle.....  | 91     |
| Goldsmith, The.....  | 75     |
| Gossip, Foreign.....   | 92     |
| Gossip, Trade.....   | 95     |
| Hereditary Short-Sightedness.....  | 91     |
| History of the Chicago Relief Fund.....                                      | 82     |
| Horological Club, Proceedings of the.....                                    | 81     |
| How to Make and Engrave Silver Bangles....                                   | 89     |
| Improved Regulator.....  | 92     |
| Institute, Washington Branch, Naval.....                                     | 73     |
| Jewelers' League, The.....   | 66, 68 |
| King, John W., Obituary.....   | 81     |
| Lathes and Lathe Work.....   | 86     |
| League, The Jewelers'.....   | 66, 68 |
| Leschot, Georges-Auguste.....  | 91     |
| Letters, Receipt of.....   | 68     |
| Letters to Watchmakers.....  | 83     |
| Lever Escapement, Problems in the Detached                                   | 93     |
| Make and Engrave Silver Bangles, How to...                                   | 89     |
| Manufacturers, Small.....  | 68     |
| Medical .....  | 94     |
| Naval Institute, Washington Branch.....                                      | 73     |
| New Barrel Arrangement for Clocks.....                                       | 92     |
| New Pendulum Clock, A.....   | 77     |
| New Sun Dial, A.....   | 78     |
| Obituary, Georges-Auguste Leschot.....                                       | 91     |
| Pendulum Clock, A New.....   | 77     |
| Plated Ware, Auction.....  | 67     |
| Practical Treatise on the Adjustment of a Four-<br>Jewel Cylinder Watch..... | 78     |
| Problems in the Detached Lever Escapement.                                   | 93     |
| Proceedings of the Horological Club.....                                     | 81     |
| Prospects of Trade, The.....   | 65     |
| Receipt of Letters.....  | 68     |
| Regulator, Improved.....   | 92     |
| Relief Fund, History of the Chicago.....                                     | 82     |
| Short-Sightedness, Hereditary.....   | 91     |
| Silver Bangles, How to Make and Engrave...                                   | 89     |
| Size of Spectacle Glasses .....  | 91     |

|  | PAGE. |
|--|-------|
| Small Manufacturers .....  | 68    |
| Sun Dial, A New.....   | 78    |
| Trade Gossip.....  | 95    |
| Trade, The Prospects of.....   | 65    |
| Trade Secrets .....  | 99    |
| Views of Correspondents.....   | 86    |
| Washington Branch, Naval Institute.....                                      | 73    |
| Watch Company, Aristarchius Plumbago and<br>his Bicycle.....                 | 69    |
| Watch, Practical Treatise on the Adjustment<br>of a Four-Jewel Cylinder..... | 78    |
| Watchmakers' Apprentices, Advice to.....                                     | 94    |
| Watchmakers, Letters to.....   | 83    |
| Whims of a Bric-à-Brac Collector.....  | 76    |

## MAY.

|   | PAGE. |
|---|-------|
| Adjustment of a Four-Jewel Cylinder Watch,<br>Practical Treatise on the .....             | 101   |
| Advice to Watchmakers' Apprentices.....   | 108   |
| Alliance, The Jeweler's Security.....   | 124   |
| American Gems.....  | 114   |
| Anchor Pallets, Tool for Retouching the.....  | 125   |
| Aristarchius Plumbago's Bicycle Watch Demag-<br>netizer.....                              | 104   |
| Articles, The Cleaning of Silver and Silver-<br>Plated .....                              | 127   |
| Arts and Customs, The Cup—Its.....  | 99    |
| Bad Effects of Speculation.....   | 97    |
| Bangles, How to Make and Engrave Silver...  | 110   |
| Brass, Coloring.....  | 128   |
| Brocot Escapement, The Roller or.....   | 124   |
| Carvers, Ingenious Wood.....  | 116   |
| Cheap Movements.....  | 98    |
| Cincinnati Relief Fund, The.....  | 119   |
| Cleaning of Silver and Silver-Plated Articles..   | 127   |
| Clock of Nuremberg, The Oldest.....   | 137   |
| Club, Proceedings of the Horological.....   | 112   |
| Coloring Brass.....   | 128   |
| Competition, Outside.....   | 99    |
| Competitive Prize for Excellence of their Com-<br>pensation in the Different Temperature. | 127   |
| Cup, The—Its Arts and Customs.....  | 99    |
| Cylinder Watch, Practical Treatise on the Ad-<br>justment of a Four-Jewel.....            | 101   |
| Detached Lever Escapement, Problems in the.   | 107   |
| Different Gravity Escapements, A Review of the  | 122   |
| Effects of Speculation, Bad.....  | 97    |
| Engrave Silver Bangles, How to Make and....   | 110   |
| Escapement, Problems in the Detached.....   | 107   |
| Escapements; A Review of the Different<br>Gravity.....                                    | 122   |
| Escapement, The Roller or Brocot.....   | 124   |
| Four-Jewel Cylinder Watch, Practical Treatise<br>on the Adjustment of a.....              | 101   |
| Fund, The Cincinnati Relief.....  | 119   |
| Gems, American.....   | 114   |
| Goldsmith, The.....   | 111   |
| Gossip, Trade.....  | 130   |
| Gravity Escapements, A Review of the Dif-<br>ferent.....                                  | 122   |
| History of Optical Instruments.....   | 126   |
| Horological Club, Proceedings of the.....   | 112   |
| How to Make and Engrave Silver Bangles....  | 110   |
| Ingenious Wood Carvers.....   | 116   |
| Instruments, History of Optical.....  | 126   |
| Insurance of Precious Stones.....   | 106   |
| Jewelers' League, The .....   | 116   |
| Jewelers' Security Alliance, The.....   | 124   |
| Lathes and Lathe Work.....  | 109   |
| League, The Jewelers'.....  | 116   |
| Letters to Watchmakers.....   | 118   |
| Lever Escapement, Problems in the Detached.   | 107   |
| Machine, New Stretching.....  | 128   |
| Make and Engrave Silver Bangles, How to...  | 110   |
| Microscopes.....  | 105   |
| Movements, Cheap .....  | 98    |
| National Robbery, Proposed.....   | 97    |
| New Stretching Machine.....   | 128   |

|  | PAGE. |
|--|-------|
| Notes, Workshop.....   | 129   |
| Oldest Clock of Nuremberg.....   | 117   |
| Opening the Regulator.....   | 128   |
| Optical Instruments, History of.....   | 126   |
| Outside Competition.....   | 99    |
| Plumbago's Bicycle Watch Demagnetizer,<br>Aristarchius.....                  | 104   |
| Practical Treatise on the Adjustment of a Four-<br>Jewel Cylinder Watch..... | 101   |
| Precious Stones, Insurance of.....   | 106   |
| Problems in the Detached Lever Escapement.                                   | 107   |
| Proceedings of the Horological Club.....                                     | 112   |
| Proposed National Robbery.....   | 97    |
| Regulator, Opening the.....  | 128   |
| Relief Fund, The Cincinnati.....   | 119   |
| Retouching the Anchor Pallets, Tool for.....                                 | 125   |
| Review of the Different Gravity Escapements..                                | 122   |
| Roller or Brocot Escapement, The.....  | 124   |
| Sailed for Europe.....   | 122   |
| Security Alliance, The Jewelers'.....  | 124   |
| Sight.....   | 115   |
| Silver and Silver-Plated Articles, The Clean-<br>ing of.....                 | 127   |
| Silver Bangles, How to make and Engrave...                                   | 110   |
| Speculation, Bad Effects of.....   | 97    |
| Stones, Insurance of Precious.....   | 106   |
| Stretching Machine, New.....   | 128   |
| Time and Timekeepers.....  | 120   |
| Tool for Retouching the Anchor Pallets.....                                  | 125   |
| Trade Gossip.....  | 130   |
| Treatise on the Adjustment of a Four-Jewel<br>Cylinder Watch, Practical..... | 101   |
| Watch Demagnetizer, Aristarchius Plumbago's<br>Bicycle.....                  | 104   |
| Watchmakers' Apprentices.....  | 108   |
| Watchmakers, Letters to.....   | 118   |
| Wood Carvers, Ingenious.....   | 116   |
| Workshop Notes.....  | 129   |

## JUNE.

|  | PAGE. |
|--|-------|
| Adjustment of a Four-Jewel Cylinder Watch,<br>Practical Treatise on the.....   | 151   |
| Advice to Watchmakers' Apprentices.....  | 160   |
| Alliance, Jewelers' Security.....  | 137   |
| Aristarchius Plumbago and his Bicycle Watch<br>Movement.....                   | 140   |
| Arts and Customs, The Cup—Its .....  | 138   |
| Balance Spring, Excelsior's.....   | 136   |
| Bangles, How to Make and Engrave Silver...                                     | 159   |
| Brass Plating, Electro.....  | 150   |
| Business, Gambling in.....   | 133   |
| Buyers Abroad.....   | 134   |
| Buyers, Peculiarities of.....  | 134   |
| Club, Proceedings of the Horological.....                                      | 147   |
| Commercial Travelers.....  | 135   |
| Cup—Its Arts and Customs, The.....   | 138   |
| Cylinder Watch, Practical Treatise on the Ad-<br>justment of a Four-Jewel..... | 151   |
| Detached Lever Escapement, Problems in the.                                    | 153   |
| Ear Piercer, Improved.....   | 149   |
| Engrave Silver Bangles, How to Make and...                                     | 159   |
| Electro-Brass Plating.....   | 150   |
| Escapement, Problems in the Detached Lever.                                    | 153   |
| Excelsior's Balance Spring.....  | 136   |
| Firm of Miller Bros.....   | 158   |
| Foreign Gossip.....  | 161   |
| Four-Jewel Cylinder Watch, Practical Treatise<br>on the Adjustment of a.....   | 151   |
| Gambling in Business.....  | 133   |
| Goldsmith, The.....  | 154   |
| Gorham Manufacturing Co.'s New Building...                                     | 155   |
| Gossip, Foreign.....   | 161   |
| Gossip, Trade.....   | 162   |
| Gravity upon the Pendulum, The Influence of.                                   | 143   |
| Horological Club, Proceedings of the.....                                      | 147   |
| How to Make and Engrave Silver Bangles....                                     | 159   |
| Improved Ear Piercers.....   | 149   |
| Influence of Gravity upon the Pendulum, The.                                   | 143   |



|  | PAGE. |
|--|-------|
| Invention of Scales .....  | 146   |
| Jewelers' League, The.....   | 136   |
| Jewelers' Security Alliance.....   | 137   |
| Lathes and Lathe Work.....   | 156   |
| League, The Jewelers'.....   | 136   |
| Letters to Watchmakers.....  | 157   |
| Lever Escapement, Problems in the Detached.....                          | 153   |
| Make and Engrave Silver Bangles, How to... ..                            | 159   |
| Miller Bros., Firm of.....   | 158   |
| Movement, Aristarchius Plumbago and his Bicycle Watch.....               | 140   |
| Naval Institute, Washington Branch.....                                  | 142   |
| New Building, The Gorham Manufacturing Co.'s.....                        | 155   |
| Nothing New under the Sun, There is.....                                 | 151   |
| Peculiarities of Buyers.....   | 134   |
| Pendulum, The Influence of Gravity upon the.....                         | 143   |
| Piercer, Improved Ear.....   | 149   |
| Plating, Electro-Brass.....  | 150   |
| Practical Science.....   | 144   |
| Practical Treatise on the Adjustment of a Four-Jewel Cylinder Watch..... | 151   |
| Problems in the Detached Lever Escapement.....                           | 153   |
| Proceedings of the Horological Club.....                                 | 147   |
| Retail Trade, The.....   | 135   |
| Scales, Invention of.....  | 146   |
| Science, Practical.....  | 144   |
| Security Alliance, Jewelers'.....  | 137   |
| Silver Bangles, How to Make and Engrave... ..                            | 159   |
| Spring, Excelsior's Balance.....   | 135   |
| There is Nothing New under the Sun.....                                  | 151   |
| Trade Gossip.....  | 162   |
| Trade, The Retail.....   | 135   |
| Travelers, Commercial.....   | 135   |
| Washington Branch, Naval Institute.....                                  | 140   |
| Watchmakers' Apprentices, Advice to.....                                 | 160   |
| Watchmakers, Letters to.....   | 157   |
| Watch Movement, Aristarchius Plumbago and his Bicycle.....               | 140   |

JULY.

|   | PAGE. |
|---|-------|
| Adjustment of a Four-Jewel Cylinder Watch, Practical Treatise on the..... | 168   |
| Advice to Watchmakers' Apprentices.....                                   | 174   |
| Alliance, The Jewelers' Security.....                                     | 185   |
| American Watches, Balloonatics and.....                                   | 175   |
| Antique Boom, The.....  | 174   |
| Antique Watches, Collection of.....                                       | 189   |
| Arts and Customs, The Cup—Its.....  | 181   |
| Balloonatics and American Watches.....                                    | 175   |
| Bangles, How to Make and Engrave Silver... ..                             | 177   |
| Bavarian Gold and Silver Work.....  | 190   |
| Blow pipe, The.....   | 190   |
| Boom, The Antique.....  | 174   |
| Bouchons, Method for Improving Depthing without Tight.....                | 190   |
| Camcos and Intaglios, A New Method of Engraving.....                      | 178   |
| Canes, Walking.....   | 170   |
| Club, Proceedings of the Horological.....                                 | 187   |
| Collection of Antique Watches.....  | 189   |
| Competition, Unwise.....  | 166   |
| Computation of Time and Changes of Style in the Calendar.....             | 182   |
| Cup—Its Arts and Customs, The.....  | 181   |
| Curse of Speculation, The.....  | 167   |
| Cylinder Watch, Practical Treatise on the Adjustment of a Four-Jewel..... | 168   |
| Detached Lever Escapement, Problems in the.....                           | 173   |
| Emery and Emery Wheels.....   | 189   |
| England, The Goldsmith's Guild of.....                                    | 171   |
| Engrave Silver Bangles, How to Make and... ..                             | 177   |
| Engraving Cameos and Intaglios, A New Method of.....                      | 178   |
| Escapement, Problems in the Detached Lever.....                           | 173   |
| Foreign Gossip.....   | 192   |
| Four-Jewel Cylinder Watch, Practical Treatise on the Adjustment of a..... | 168   |

AUGUST.

|   | PAGE. |
|---|-------|
| Address, Change of.....   | 199   |
| Adjustment of a Four-Jewel Cylinder Watch, Practical Treatise on the..... | 207   |
| Alliance, The Jewelers' Security.....                                     | 213   |
| Ancient Ideas Respecting the Origin of Diamonds.....                      | 224   |
| Apertures of the Principal Telescopes.....                                | 205   |
| Business Aspect, The Improving.....                                       | 199   |
| Business Failures.....  | 198   |
| Change of Address.....  | 199   |
| Cholera.....  | 199   |
| Cholera, How to Prevent.....  | 209   |
| Clocks, Invention of Wheel.....   | 221   |
| Clocks, Old.....  | 224   |
| Club Proceedings of the Horological.....                                  | 213   |
| Commercial Honor.....   | 197   |
| Commercial Travelers, The National Association of.....                    | 208   |
| Computation of Time and Changes of Style in the Calendar.....             | 203   |
| Cup—Its Art and Customs, The.....   | 200   |
| Cut in Watch Movements, The.....  | 223   |
| Cylinder Watch, Practical Treatise on the Adjustment of a Four-Jewel..... | 207   |
| Day, Jewelers'.....   | 216   |
| Detached Lever Escapement, Problems in the.....                           | 220   |
| Diamonds, Ancient Ideas Respecting the Origin of.....                     | 224   |
| Engraving of Gems, The.....   | 206   |
| Failure of S. M. Rothschild.....  | 199   |
| Failures, Business.....   | 198   |
| Foreign Gossip.....   | 225   |
| Galvani, Luigi.....   | 224   |
| George Graham and his Watches.....  | 217   |
| Gems, The Engraving of.....   | 206   |
| German Branch of Industry Becoming Obsolete, A.....                       | 212   |
| Goldsmithing, the History of.....   | 210   |
| Gossip, Foreign.....  | 225   |
| Gossip from Providence.....   | 212   |
| Gossip, Trade.....  | 227   |
| History of Goldsmithing, The.....   | 210   |
| Honor, Commercial.....  | 197   |
| Hopkinson, D. H., Obituary.....   | 195   |

|   | PAGE. |
|---|-------|
| Horological Club, Proceedings of the.....                                 | 214   |
| How Antiquarians Decipher Illegible Writings and Fix Dates.....           | 209   |
| How to Prevent Cholera.....   | 209   |
| Improving Business Aspects, The.....                                      | 199   |
| Industry Becoming Obsolete, A German Branch of.....                       | 212   |
| Invention of Wheel Clocks.....  | 221   |
| Jewelers' Day.....  | 216   |
| Jewelers' League, The.....  | 213   |
| Jewelers' Security Alliance.....  | 213   |
| Lathes and Lathe Work.....  | 221   |
| League, The Jewelers'.....  | 213   |
| Lever Escapement, Problems in the Detached.....                           | 220   |
| Luigi Galvani.....  | 224   |
| Movements, The Cut in Watch.....  | 223   |
| National Association of Commercial Travelers, The.....                    | 208   |
| Nickel in the United States.....  | 222   |
| Notes, Workshop.....  | 226   |
| Obituary, D. H. Hopkin on.....  | 195   |
| Old Clocks.....   | 224   |
| Pirates of Patents.....   | 198   |
| Practical Treatise on the Adjustment of a Four-Jewel Cylinder Watch.....  | 207   |
| Principal Telescopes, Apertures of the.....                               | 205   |
| Problems in the Detached Lever Escapement.....                            | 220   |
| Proceedings of the Horological Club.....                                  | 214   |
| Providence, Gossip from.....  | 212   |
| Rare Case for Spectacles, A.....  | 217   |
| Style in the Calendar, Computation of Time and Changes of.....            | 203   |
| Security Alliance, The Jewelers'.....                                     | 212   |
| Sight.....  | 215   |
| Spectacles, A Rare Case for.....  | 217   |
| Telescopes, Apertures of the Principal.....                               | 205   |
| Tourbillon Escapement, The.....   | 202   |
| Trade Gossip.....   | 227   |
| Treatise on the Adjustment of a Four-Jewel Cylinder Watch, Practical..... | 207   |
| United States, Nickel in the.....   | 222   |
| Watch Movements, The Cut in.....  | 223   |
| Wheel Clocks, The Invention of.....                                       | 221   |
| Workshop Notes.....   | 226   |

SEPTEMBER.

|  | PAGE. |
|--|-------|
| Advice to Watchmakers' Apprentices.....                          | 252   |
| Agates and the Agate Industry.....                               | 259   |
| Albrecht Durer.....  | 239   |
| Alliance, The Jewelers' Security.....                            | 251   |
| Aristarchius Plumbago's Bicycle Watch Movement.....              | 257   |
| Bangles, How to Make and Engrave Silver... ..                    | 246   |
| Birch, John S., Obituary.....                                    | 257   |
| Brass Articles, Coloring and Polishing.....                      | 259   |
| Catalogue, An Elegant.....                                       | 245   |
| Club, Proceedings of the Horological.....                        | 245   |
| Coloring and Polishing Brass Articles.....                       | 259   |
| Computation of Time and Changes of Style in the Calendar.....    | 236   |
| Correspondents, Views of.....                                    | 239   |
| Crown Jewels, The French.....                                    | 253   |
| Dennison Manufacturing Company, The.....                         | 246   |
| Detached Lever Escapement, Problems in the.....                  | 241   |
| Diamonds, Stage.....   | 255   |
| Different Gravity Escapements, Review of the.....                | 252   |
| Durer, Albrecht.....   | 239   |
| Elegant Catalogue, An.....                                       | 245   |
| Engrave Silver Bangles, How to Make and... ..                    | 246   |
| Escapement, Problems in the Detached Lever.....                  | 241   |
| Escapements, Review of the Different Gravity.....                | 252   |
| Experiments of the Old Masters of Horology, A Review of the..... | 248   |
| Foreign Gossip.....  | 261   |
| French Crown Jewels, The.....                                    | 253   |
| Goldsmithing, The History of.....                                | 231   |
| Goods on Memorandum.....   | 229   |
| Gossip, Foreign.....   | 261   |
| Gossip from Providence.....                                      | 242   |
| Gossip, Trade.....   | 263   |
| History of Goldsmithing, The.....                                | 231   |
| Horological Club, Proceedings of the.....                        | 245   |
| Horology, A Review of the Experiments of the Old Masters of..... | 248   |
| How to Make and Engrave Silver Bangles... ..                     | 246   |
| Indicator of the Mainspring, Up and Down... ..                   | 253   |
| Jewelers' League, The.....                                       | 251   |
| Jewelers' Security Alliance, The.....                            | 251   |
| Jewels and Jewelry.....  | 233   |
| Jewels, The French Crown.....                                    | 253   |
| Lathes and Lathe Work.....                                       | 247   |
| League, The Jewelers'.....                                       | 251   |
| Lever Escapement, Problems in the Detached.....                  | 241   |
| Mainspring, Up and Down Indicator of the... ..                   | 253   |
| Make and Engrave Silver Bangles, How to... ..                    | 246   |
| Manufacturing Company, The Dennison.....                         | 246   |

The Jewelers' Circular and Horological Review.

|   | PAGE. |
|---|-------|
| Market, Spanish-American                                    | 230   |
| Marx, Morocco—Ottavary                                      | 257   |
| Movement, Aristarchus Plumbago's Bicycle                    | 257   |
| Notes, Workshop   | 262   |
| Ottavary—John S. Birch                                      | 257   |
| Ottavary—Monroe Marx  | 257   |
| Old Masters of Horology, A Review of the Experiments of the | 248   |
| Order to be Observed in Repairing Watches, The              | 241   |
| Plumbago's Bicycle Watch Movement, Aristarchus              | 257   |
| Polishing Brass Articles, Coloring and                      | 259   |
| Precious Stones, Superstition Regarding                     | 256   |
| Problems in the Detached Lever Escapement                   | 241   |
| Proceedings of the Horological Club                         | 245   |
| Providence, Gossip from                                     | 242   |
| Repairing Watches, The Order to be Observed in              | 241   |
| Review of the Different Gravity Escapements                 | 252   |
| Review of the Experiments of the Old Masters of Horology    | 248   |
| Rules of Auld Lang Syne for Owners of Watches               | 254   |
| Security Alliance, The Jewelers'                            | 251   |
| Sight   | 243   |
| Silver Bangles, How to Make and Engrave                     | 246   |
| Spanish-American Market                                     | 230   |
| Stage Diamonds  | 255   |
| Stemwinder of the Last Century, A                           | 254   |
| Story of a Watch, The                                       | 235   |
| Style in the Calendar, Computation of time and Changes of   | 236   |
| Superstition Regarding Precious Stones                      | 256   |
| Trade Gossip  | 263   |
| Up and Down Indicator of the Mainspring                     | 253   |
| Views of Correspondents                                     | 239   |
| Watchmakers' Apprentices, Advice to                         | 252   |
| Watch Movement, Aristarchus Plumbago's Bicycle              | 257   |
| Workshop Notes  | 262   |
| Why Business Men Fail                                       | 236   |
| Years, Months and Weeks                                     | 237   |

OCTOBER.

|   | PAGE. |
|---|-------|
| Advice to Watchmakers' Apprentices                          | 284   |
| Age of Inventions, The                                      | 296   |
| Alliance, The Jewelers' Security                            | 284   |
| Annealing of Steel, The Tempering and                       | 280   |
| Architecture, Precious Metals in                            | 279   |
| Art Work in Precious Metals, Russian                        | 267   |
| Bangles, How to Make and Engrave Silver                     | 295   |
| Black Forest, Clockmaking in the                            | 273   |
| Bric-à-brac Hunter in Morocco, A                            | 294   |
| Business Outlook, The                                       | 266   |
| Business Practice, A Vicious                                | 266   |
| Chinese Children and their Diamonds                         | 275   |
| Circular—Its Future, The                                    | 265   |
| Clockmaking in the Black Forest                             | 273   |
| Computation of Time and Changes of Style in the Calendar    | 276   |
| Crown Diamonds, Exhibition of the French                    | 292   |
| Detached Lever Escapement, Problems in the                  | 288   |
| Diamonds, Chinese Children and their                        | 278   |
| Diamonds, Exhibition of the French Crown                    | 292   |
| Diamonds, Some Famous                                       | 275   |
| Engrave Silver Bangles, How to Make and                     | 295   |
| Escapement, Problems in the Detached Lever                  | 288   |
| Exhibition of the French Crown Diamonds                     | 292   |
| Experiments of the Old Masters of Horology, A Review of the | 282   |
| Exposition of Goldsmithing at Nuremberg in 1885             | 294   |
| Famous Diamonds, Some                                       | 275   |
| Foreign Gossip  | 297   |
| French Crown Diamonds, Exhibition of the                    | 292   |
| Goldsmithing, History of                                    | 285   |
| Gossip, Foreign   | 297   |
| Gossip from Providence                                      | 281   |
| Gossip of the Month   | 267   |
| Gossip, Trade   | 269   |
| History of Goldsmithing                                     | 285   |
| Hooking in of the Mainspring, The                           | 273   |
| Horology, A Review of the Experiments of the Old Masters of | 282   |
| How to Make and Engrave Silver Bangles                      | 295   |
| How to Measure and Fit Spectacle Glasses                    | 274   |
| Hunter in Morocco, A Bric-à-brac                            | 294   |
| Inventions, The Age of                                      | 296   |
| Jewelers' League, The                                       | 284   |
| Jewelers' Security Alliance, The                            | 284   |
| Jewels and Jewelry  | 270   |
| Lathes and Lathe Work                                       | 295   |
| League, The Jewelers'                                       | 284   |
| Lever Escapement, Problems in the Detached                  | 288   |

|   | PAGE. |
|---|-------|
| Magnetized, To Prevent Watches from Being                   | 278   |
| Mainspring, The Hooking in of the                           | 273   |
| Make and Engrave Silver Bangles, How to                     | 295   |
| Measure and Fit Spectacle Glasses, How to                   | 274   |
| Metals in Architecture, Precious                            | 279   |
| Metals, Russian Art Work in Precious                        | 267   |
| Morocco, A Bric-à-brac Hunter in                            | 294   |
| Notes, Workshop   | 298   |
| Nuremberg, Exposition of Goldsmithing at, in 1885           | 294   |
| Old Masters of Horology, A Review of the Experiments of the | 282   |
| Palladium   | 293   |
| Precious Metals in Architecture                             | 279   |
| Precious Metals, Russian Art Work in                        | 267   |
| Problems in the Detached Lever Escapement                   | 288   |
| Providence, Gossip from                                     | 281   |
| Review of the Experiments of the Old Masters of Horology, A | 282   |
| Russian Art Work in Precious Metals                         | 267   |
| Russian Reproductions                                       | 289   |
| Security Alliance, The Jewelers'                            | 284   |
| Silver Bangles, How to Make and Engrave                     | 295   |
| Some Famous Diamonds  | 275   |
| Spectacle Glasses, How to Measure and Fit                   | 274   |
| Style in the Calendar, Computation of Time and Changes of   | 276   |
| Tempering and Annealing of Steel, The                       | 280   |
| To Prevent Watches from Being Magnetized                    | 278   |
| Trade Gossip  | 299   |
| Vicious Business Practice, A                                | 266   |
| Watchmakers' Apprentices, Advice to                         | 284   |
| Workshop Notes  | 298   |

NOVEMBER.

|   | PAGE. |
|---|-------|
| Alliance, The Jewelers' Security                            | 321   |
| Amber, Some Facts about                                     | 312   |
| Barrel and Spring, The Relation of                          | 313   |
| Business, Dry Rot in  | 304   |
| Business Outlook Improving, The                             | 301   |
| Centers, The Outlook at Trade                               | 328   |
| Certificates of Rates, Regulations Governing the Issue of   | 327   |
| Changing of the Dials                                       | 311   |
| Clocks, The Decoration of                                   | 315   |
| Club, Proceedings of the Horological                        | 318   |
| Current Humor   | 330   |
| Decoration of Clocks, The                                   | 315   |
| Dials, Changing of the                                      | 311   |
| Diversity of Interests in the Trade                         | 302   |
| Dry Rot in Business   | 304   |
| Exact Time is Transmitted, How                              | 329   |
| Experiments of the Old Masters in Horology, A Review of the | 322   |
| Foreign Gossip  | 333   |
| Free Trade and Protection                                   | 303   |
| Goldsmithing, The History of                                | 334   |
| Gossip, Foreign   | 333   |
| Gossip of the Month   | 305   |
| Gossip, Trade   | 335   |
| History of Goldsmithing, The                                | 324   |
| Horological Club, Proceedings of the                        | 318   |
| Horology, A Review of the Experiments of the Old Masters of | 322   |
| How Exact Time is Transmitted                               | 329   |
| Humor, Current  | 330   |
| Improving, The Business Outlook                             | 301   |
| Interests in the Trade, Diversity of                        | 302   |
| Issue of Certificates of Rates, Regulations Governing the   | 324   |
| Jewelers' Security Alliance, The                            | 321   |
| Letters, Our Providence                                     | 320   |
| Notes, Workshop   | 334   |
| Old Masters of Horology, A Review of the Experiments of the | 322   |
| Our Providence Letter                                       | 320   |
| Outlook at Trade Centers, The                               | 328   |
| Proceedings of the Horological Club                         | 318   |
| Protection, Free Trade and                                  | 303   |
| Regulating of Watches, The                                  | 317   |
| Regulations Governing the Issue of Certificates of Rates    | 327   |
| Relation of Barrel and Spring, The                          | 313   |
| Review of the Experiments of the Old Masters of Horology, A | 322   |
| Russian Reproductions                                       | 308   |
| Security Alliance, The Jewelers'                            | 321   |
| Sight   | 321   |
| Some Facts about Amber                                      | 312   |
| Spring, The Relation of Barrel and                          | 313   |
| Sweepings   | 332   |
| Time is Transmitted, How Exact                              | 329   |
| Tortoise Shell  | 312   |
| Trade Centers, The Outlook at                               | 328   |
| Trade, Diversity of Interests in the                        | 302   |
| Trade Gossip  | 335   |

|                               | PAGE. |
|-------------------------------|-------|
| Traders' and Travelers' Union | 329   |
| Watches, The Regulating of    | 317   |
| Workshop Notes                | 334   |

DECEMBER.

|   | PAGE. |
|---|-------|
| Advice to Watchmakers' Apprentices                          | 345   |
| Annual Dinner, etc., Tenth                                  | 358   |
| Bangles, How to Make and Engrave Silver                     | 346   |
| Boxes, Ingenious Music                                      | 347   |
| Cameos, Something about                                     | 348   |
| Carving, Swiss Wood   | 344   |
| Club, Proceedings of the Horological                        | 354   |
| Congress and Commercial Interests                           | 337   |
| Credit System throughout the World, The                     | 349   |
| Dinner, etc., Tenth Annual                                  | 358   |
| Engrave Silver Bangles, How to Make and                     | 346   |
| Exhibitions, National                                       | 339   |
| Experiments of the Old Masters of Horology, A Review of the | 367   |
| Fashions in Jewelry   | 355   |
| Gossip of the Month   | 340   |
| Gossip, Trade   | 370   |
| Holiday Trade, The  | 339   |
| Horological Club, Proceedings of the                        | 354   |
| Horology, A Review of the Experiments of the Old Masters of | 367   |
| How to Make and Engrave Silver Bangles                      | 346   |
| How to make Retail Stores Attractive                        | 333   |
| Infringements of Patents                                    | 347   |
| Ingenious Music Boxes                                       | 347   |
| Jewelers' League, The                                       | 366   |
| Jewelry, Fashions in  | 355   |
| League, The Jewelers'                                       | 366   |
| Letter, Our Providence                                      | 366   |
| Make and Engrave Silver Bangles, How to                     | 346   |
| Music Boxes, Ingenious                                      | 347   |
| National Exhibitions  | 339   |
| Old Masters of Horology, A Review of the Experiments of the | 367   |
| Our Providence Letter                                       | 366   |
| Patents, Infringements of                                   | 347   |
| Proceedings of the Horological Club                         | 354   |
| Providence Letter, Our                                      | 366   |
| Review of the Experiments of the Old Masters of Horology, A | 367   |
| Russian Reproductions                                       | 359   |
| Silver Bangles, How to Make and Engrave                     | 346   |
| Something about Cameos                                      | 348   |
| Stores Attractive, How to Make Retail                       | 338   |
| Swiss Wood Carving  | 344   |
| Trade Gossip  | 370   |
| Trade, The Holiday  | 339   |
| Travelers' Taxes  | 348   |
| Watchmakers' Apprentices, Advice to                         | 345   |
| Wood Carving, Swiss   | 344   |
| Workshop Notes  | 369   |

JANUARY.

|  | PAGE. |
|--|-------|
| Abuse of Credit and Hard Times             | 374   |
| A Few Words About Ourselves                | 373   |
| A National Bankruptcy Law                  | 376   |
| Bankruptcy Law, A National                 | 376   |
| Business, The Outlook for                  | 375   |
| Cost of Obtaining Foreign Patents          | 400   |
| Credit and Hard Times, Abuse of            | 374   |
| Detached Lever Escapement, Problems in the | 387   |
| Fashions in Jewelry                        | 391   |
| Foreign Gossip                             | 401   |
| Foreign Patents, Cost of Obtaining         | 400   |
| Goldsmithing, The History of               | 384   |
| Gossip, Foreign                            | 401   |
| Gossip of the Month                        | 376   |
| Horological Club, Proceedings of the       | 395   |
| Jewelry, Fashions in                       | 391   |
| Lathes and Lathe Work                      | 386   |
| Musical Boxes and their Manufacture        | 397   |
| Notes, Workshop                            | 402   |
| Our Providence Letter                      | 398   |
| Ourselves, A Few Words About               | 373   |
| Patents, Recent                            | 399   |
| Pearl Fisheries on the Pacific Coast       | 395   |
| Problems in the Detached Lever Escapement  | 387   |
| Proceedings of the Horological Club        | 395   |
| Recent Patents                             | 399   |
| Reproductions, Russian                     | 379   |
| Swiss Watches for the American Market      | 400   |
| The American Market, Swiss Watches for     | 400   |
| The History of Goldsmithing                | 384   |
| The Jewelers' League                       | 399   |
| The Outlook for Business                   | 375   |
| The Pacific Coast, Pearl Fisheries on      | 395   |
| The Regulating of Watches                  | 388   |
| Trade Gossip                               | 403   |
| Watches, The Regulating of                 | 388   |
| Workshop Notes                             | 402   |

**SPECIAL NOTICES.**

**Notices under this Heading, not to exceed Six Lines, \$1.00 each insertion.**

Advertisers having letters addressed in care of this office, must inclose postage for answers forwarded.

**SHOW CASES**—For sale, three counter cases and four upright glass cases. Geo. W. Shiebler, 8 Liberty Place, N. Y.

**FOR SALE CHEAP**—A full set of electrotypes for a tool and material catalogue. C. W. Little, Wholesale Jeweler, Denver, Colo.

**WANTED**—A few Elgin movements No. 7, No. 6, No. 94. \$1.00 premium over the net retail price. Address D. H., care Jewelers' Circular.

**EDWARD P. FOX**—Manufacturer of Diamond Mountings and Rich Jewelry. Order work from design, and all kinds of Repairing a specialty. No. 17 Maiden Lane, N. Y.

**FACTORY TO LET**—22 x 45, with or without steam power. Excellent light, suitable for diamond cutting or manufacturing jeweler. Apply to F. Demmert & Son, 6 Maiden Lane, N. Y.

**WANTED**—A first-class foreign watchmaker, lately arrived, French, Swiss or Swede preferred. None but first-class need address. Jos. W. Forsyth, Jr., 70 N. Second street, Philadelphia, Pa.

**WANTED**—A situation by a practical watchmaker and engraver, is also a good salesman. A first-class workman in every respect. Best of recommendations given. Address M. B., care Jewelers' Circular.

**FOR SALE**—An old and well-established jewelry store in a large and thriving city in the state of Connecticut. Only moderate capital required. Inquire of Oppenheimer Bros. & Veith, 35 Maiden Lane, New York.

**WANTED**—A situation by a young man in the jewelry business who has had three years' experience at the business. The best of reference given. Address Frank S. McKee, 136 East Federal street, Youngstown, Ohio.

**FOR SALE**—Fourteen volumes of "The Jewelers' Circular," several volumes of "The Jewelers' Journal," and "Watchmaker and Metal Worker." I want a good, cheap Universal lathe. Address J. H. Bell, Tarrytown, N. C.

**MOSELEY & CO.** Elgin, Ill., manufacturers of the "Moseley" Lathe, with full line of fixtures and attachments. Designed especially for the watchmaker and repairer. Combining accuracy, durability, convenience and style.

**WANTED AT ONCE**—A good watchmaker. One who can make a sale when required. Must have good references, sober habits, and strictly honest. Will pay good wages and will give permanent situation. Address F. E. Hollar, Shippensburg, Pa.

**SITUATION** wanted by a young man with a good set of tools, American lathe, etc., as watchmaker, jeweler and engraver. Understands gold working and manufacturing, also fine monogram engraving. Address E. N. Graver, care Jewelers' Circular.

**FOR SALE**—A jewelry store on one of the leading avenues in Brooklyn, N. Y., doing a fair business and a good run of bench work. Satisfactory reasons given for disposing of the business. For particulars address S. T. Clinton, care Jewelers' Circular.

**A YOUNG MAN** who has had six years' experience in the diamond and jewelry trade, also experience in silver plate trade, desires a position with diamond jewelry or silverware house. Has traveled. Best of references. Address L. C., care Jewelers' Circular.

**WANTED**—Situation by a watchmaker of over fifteen years' experience. Can do all kind of watch and job work usually done. Or, will put my experience against capital and engage in the business in some good locality. Address J. F. B., Box 1605, Muskegon, Mich.

**FOR SALE**—The leading jewelry business in a live town of 12,000 inhabitants, doing a profitable business. Purchaser can buy all the stock, about \$4,500, or will keep part of the jewelry. Ill health and change of business a necessity. Address E., Box 771, Lima, Ohio.

**FOR SALE**—The leading jewelry store in Carlisle, Pa., a thriving town of 7,000 inhabitants. Store established over 40 years. Doing a good business and room for a large increase. Will sell with or without fixtures. Cash required about \$5,000. Address R. H. Conly, Carlisle, Pa.

**SITUATION** wanted at the bench and as salesman with an experienced workman to finish the trade. Those who can use a steady young man of 20 and three and a half years' experience in the trade, and can furnish satisfactory reference, address "E.," care Jewelers' Circular.

**GEORGE E. WILKINS**, manufacturer and importer of cutters for watchmakers' use, stem-winding cutters of all the different forms, rounding up cutters of the finest quality, also ratchet cutters. A large stock of second hand and new marine chronometers. No. 21 South Salina street, Syracuse, N. Y.

**WANTED**—In a first-class establishment in prominent city near New York, a jobbing jeweler and letter and monogram engraver, or a good salesman and engraver. Must be perfectly reliable in every way, strictly temperate and well recommended. Address, with references and wages desired, F. H. G., care Carter, Sloan & Co., 15 Maiden Lane, N. Y.

**FOR SALE**—A well-established jewelry business in a fine growing town of 1,800 inhabitants, situated in northern Iowa. County seat, two railroads, churches and schools. Stock invoices about \$1,500. Plenty work, and just the chance for a young man with a small capital. Address R. H. W., care Jewelers' Circular.

**FOR SALE**—An old-established jewelry business in central New York. Established over forty years, with a good reputation, in a thrifty town of 5,000 inhabitants, one of the very best locations. An opportunity for an enterprising man to make a success. Stock and fixtures \$6,000. Will sell any part of same to suit purchaser. For terms address Cross & Bequelin, 21 Maiden Lane, N. Y.

**FOR SALE**—An old-established jewelry business which the present owner started 30 years ago. Stock consists of diamonds, watches, clocks, jewelry, silver and plated ware, etc. to the amount of about \$15,000, all well selected and in good order. Store situated in a city of 60,000 inhabitants. Will sell on easy terms to a responsible purchaser. The strictest investigation is invited. Address A. B. C., care Jewelers' Circular.

**TO THE TRADE**—I make a specialty of supplying the Trade with stones for jobbing purposes. Parties having jewelry out of which the stones have been lost, sending their orders by mail or express, will have them promptly attended to. A large stock of cameos, pearls, turquoise, garnets, amethysts, doublets, foil backs, white and colored imitation stones on hand. All kinds of setting done for the Trade. W. Archibald, 73 Nassau street, New York.

**FOR SALE**—Stock and business (good will) of one of a few of the very best paying jewelry stores in southern Michigan, in one of the most growing and promising towns of the state. Six to eight thousand dollars, half cash, balance on time at low interest on well secured paper. No played out, busted up business, but a rare chance to step into a nice paying business, one that will bear the closest scrutiny. Last year's business the best in 20 years. Best of reasons for selling. Address X. Y. Z., care Jewelers' Circular.

**FOR SALE**—A fine jewelry store in a beautiful thriving western city of 32,000 inhabitants. Has been established 6 years. Fixtures black walnut, nearly new. Store front large plate glass, fine location, cheap rent. Would prefer to sell stock with fixtures, but will sell fixtures only if stock is not wanted. Would want purchaser to take all bulky goods, like clocks and hollow ware. It is an excellent chance for a practical workman. Fixtures would invoice about \$1,800. For further particulars address G. Q., care Jewelers' Circular.

**PATENT WATCH REGULATORS**—Having improved my patent regulators and making them under my own supervision, I now furnish 3 grades to fit all watches, one style fitting all bridge watches, either ladies' or gent's, Swiss or American. Two other sizes fit all full plate watches. Making 3 sizes in all, fit all watches in the market. Send for price list. Medium priced gold and roll gold jewelry a specialty, and at prices 20 per cent. below everybody. Send for selection package. Terms cash. Not over 30 days' time given under any consideration. Buying and selling for cash I can and will sell goods so low it will surprise you. J. A. Await, 177 Vine street, Cincinnati, O.

**FOR SALE**—The retail stock and fixtures of jewelry store located at 65 State street (Central Music Hall Building), Chicago. The best location and cheapest rent on the street, being located only five doors (on same block) from the great dry-goods house of Marshall, Field & Co. The reason for selling is we intend to go up-stairs for larger accommodations for our wholesale and manufacturing business. Amount to purchase from three to five thousand dollars worth. Will sell for part cash, balance secured. For a live man this is an opportunity to secure an established business seldom offered. Lease extends a year from next May. Call on or address R. D. Kirby, Manager, Chicago Jewelry Mfg. Co., 65 State street, Chicago.

**FOR SALE**—The business of the late John Chamberlain, of Greensboro, North Carolina. This prosperous, first-class jewelry and watch establishment, to a man with a proper knowledge of the business, is an extraordinary good chance. It is well-established and thoroughly known in all the adjacent manufacturing villages in the neighborhood, and bears an enviable reputation, especially its repairing department. It is now, and has been for years, returning a handsome income. The subscriber wishes to sell it without delay. In the meantime the stock will be kept complete, and every endeavor will be made to keep it up to the high standard of its former owner. Climate very healthy. For further particulars address Sarah Chamberlain, Administratrix, Greensboro, N. C.

**BUYERS' DIRECTORY.**

**NEW YORK.**

**Assayers and Sweep Smelters.**

**Wundoehl, H.**—Gold and Silver Refiner, Assayer and Sweep Smelter. 21 John Street, N. Y.

**Badges and Medals.**

**Stockwell & Newman**—19 John Street. Manufacturers of Badges, Medals and Presentation Pieces in Gold and Silver. Also Jewelry and Mounters of Diamonds. Designs supplied.

**Wilkinson, C. B.**—Manufacturing Jeweler, 8 John Street, N. Y. Medals, Badges and Masonic Jewelry a Specialty. Designs furnished free upon application.

**Band Rings.**

**Knapp, Charles**, 41 Maiden Lane, N. Y. Specialty: Superior Band Rings, also Ring Shanks & Heads for Seal and Diamond Rings.

**Black Onyx Jewelry.**

**Cox & Sedgwick**—Manufacturers of Black Onyx Jewelry, No. 26 John St. New York.  
**Lawson, Samuel**—No. 18 John Street. Manufacturer of Black Onyx Jewelry. Coral repaired for the trade. Goods sent on approval to responsible dealers.  
**Woglom & Miller**—Manufacturers of (exclusively) Black Onyx Jewelry, 32 & 34 John St., N. Y.

**Blue Enameled Lockets.**

**Bissinger, Philip & Co.**—Importers of Diamonds Pearls and Precious Stones. Agent for the Bohemian Garnet Goods. Blue Enameled Lockets, 22 John St., N. Y.  
**Hess & Schliesser**—Importers of Diamonds, Fine Jewelry and Novelties in French Goods. Specialties: Gold and Blue Enameled Lockets, Charms and Crosses. 25 Maiden Lane.

**Bohemian Garnet Jewelry.**

**Bissinger, Philip & Co.**—Importers of Diamonds, Pearls and Precious Stones. Sole Agent for the Bohemian Garnet Jewelry. Blue Enameled Lockets. 22 John St.

**Boxes, Wood Mailing and Nested.**

**Maine Manufacturing Co.**—Successors to Swift M'fg Co., makers of Wood Mailing and Nested Boxes for Mailing and Express purposes. J. Spencer Taylor, Agent, 13 Courtlandt St., N. Y.  
**Wiesbauer, J.**—Manufacturer of the Sliding Cover Wood Mailing Boxes. All Sizes Made to Order. Buffalo, N. Y.

**Clock Companies.**

**Ansonia Clock Co.**—Manufacturers of every description of Clocks. 11 to 21 Cliff street, New York.  
**Kroeber, F.**—Manufacturer and Dealer in American and French Clocks, No. 14 Cortlandt Street.  
**New Haven Clock Co.**—16 and 18 Park Place, N. Y.  
**Seth Thomas Clock Co.**—20 Murray Street, N. Y.  
**Waterbury Clock Co.**—M. Bailey, Treasurer, Manufs and Jobbers, No. 4 Cortland St., N. Y., and No. 197 State Street, Chicago.  
**Welch, E. N., Manufacturing Co.**—Manufacturers of American Clocks. No. 6 Warren St.  
**Wm. L. Gilbert Clock Co.**—No. 6 Murray Street, Manufacturers of Clocks. Factories, Winsted, Conn.  
**Yale Clock Co.**—Manufacturers of Novelties in Clocks, 52 Maiden Lane, N. Y.

**Cameo Cutters, Etc.**

**Peiter, Theodore**—Cameo and Intaglio Engraver. Patentee of the Cameo-Intaglio. No. 2 Bond Street, near Broadway, Room 4 New York.

**Charms & Gold Watch Keys.**

**Rupp & Held**—Manufacturing Jewelers, Charms and Gold Watch Keys, with French and English Ratchets, a specialty. 15 John St., N. Y.

**Crucibles.**

**Berge, J. & H.**—Established 1850. Importers of Sand Crucibles, Covers, Chemical Porcelain, Glassware, and Jewelers' and Assayers' Supplies, 95 John Street, N. Y.

**Cutlery.**

**Harrison Bros. & Howson**—Manufacturers of Fine Ivory and Pearl Table and Pocket Cutlery, Carvers in Cases; Nutpicks, Nuteracks and goods suitable for the jewelry trade. 126 Chambers Street. W. C. Burkinshaw, Sole Agent.

**Diamond Brokers.**

**Anderson, Otis**—Diamond Merchant and Broker, always ready to pay cash for bargains in Diamonds and Precious Stones, 4 & 6 John Street, N. Y.  
**Bernhardt, Richard**—Diamond Broker and Importer, 65 Nassau Street (Room 6), N. Y. Paris, 20, rue des Petites-écuries.

**Friend S. & Son**—Brokers and dealers in Diamonds  
33 John Street, cor. Nassau St. New York.

**Herbert, R. J.**—Diamond Broker and Dealer.  
26 Maiden Lane.

#### Diamond Importers.

**Bernhard, A. & Co.**—Importers of Diamonds and  
Manufacturers of First-class Diamond Jewelry,  
Diamond Settings for Manufacturing Jewelers.  
Catalogue of Designs for the Trade free of charge.  
No. 2 Maiden Lane, New York.

**Bissinger, Philip & Co.**—Importers of Diamonds,  
Pearls and Precious Stones. Agent for the Bohemian  
Garnet Goods. Blue Enameled Locketts.  
No. 22 John St., N. Y.

**Bruhl, D. & M.**—Established in 1848. 14 Maiden  
Lane, N. Y.; 111 Broad Street, Providence, R.  
I.; 14 Rue Bleue, Paris.

**Brunswick, S. & Co.**—Importers of Diamonds.  
17 Maiden Lane, New York. Paris, Rue Lafayette.  
Amsterdam, Damsstraat.

**Citroen, L. B., & Co.**—Diamonds. 21 John St.,  
N. Y. Cutting Works, 57 & 61 Rapenburger-  
straat, Amsterdam. House in Paris, 44 Rue  
Lafitte.

**Faulkenau, Oppenheimer & Co.**—Manufacturers.  
Diamonds and Diamond Jewelry. 40 Maiden  
Lane, N. Y.

**Fera, Henry**—Importer of Diamonds, and Manu-  
facturer of Fine Diamond Jewelry. 4 & 6 John  
Street, New York. Amsterdam, Holland, 23  
Loojersgracht.

**Fox, M. & Co.**—Importers of Diamonds, Rubies,  
Sapphires and Fancy Gems. No. 1 Maiden  
Lane, New York.

**Hedges, Wm. S. & Co.**—Importers of Diamonds  
No. 170 Broadway, corner Maiden Lane.

**Kuhn, Doerffinger, & Co.**—Manufacturing Jew-  
elers and Importers of Diamonds, 18 John street  
New York

**Leberthon, L. M.**—Importer of Diamonds and  
Manufacturer of Fine Jewelry. 14 John Street,  
N. Y.

**Neresheimer, E. Aug. & Co.**—Importer of Dia-  
monds, No. 21 Maiden Lane, New York.

**Randel, Baremore & Billings**—Importers of Dia-  
monds, corner Maiden Lane and Nassau St.

**Saril, S.**—Importer of Diamonds, 182 Broadway,  
N. Y. Branch of Vve. H. A. Marchand & Frères,  
47 Rue Le Peletier, Paris.

**Saunders & Ives.**—Importers of Diamonds and  
other Precious Stones. No. 26 Maiden Lane.

**Smith, Alfred H. & Co.**—Importers of Diamonds,  
No. 182 Broadway.

**Taylor & Brother.**—Importers of Diamonds  
and Diamond Jewelry. 676 Broadway.

**Wickham, D. H. & Co.**—Importer of Diamonds.  
No. 31 Holborn Viaduct, London, 24 Maiden  
Lane, New York.

**Wolf, G. A.**—Importer of Diamonds, Rubies,  
Sapphires, Pearls, and other Precious Stones,  
65 Maiden Lane, New York. 12 Rue de Chateau-  
dun, Paris.

#### Diamond Jewelry.

**Bornemann, Louis.**—Importer of Diamonds and  
Manufacturer of Rich Diamond Jewelry, 19 John  
Street, New York.

**Chalumeau, D.**—Diamond Jeweler and Manu-  
facturer of Mountings. Novelties and Artistic Jew-  
elry. No. 3 Maiden Lane, New York.

**Goldsmith, Ingomar & Co.**—Manufacturers of  
Diamond Mountings and Diamond Jewelry, 61  
Nassau Street, New York.

**Hartje, G. & F.**—Manufacturers of Diamond and  
Fine Jewelry, 39 Union Square, N. Y.

**Haug & Luthy.**—Manufacturers of Fine Diamond  
Mountings, etc. No. 130 Fulton St., N. Y.

**Heller & Baydel.**—Manufacturers of Diamond  
and Pearl Jewelry, and Dealers in Diamonds,  
Paris, No. 13 Rue de la Harpe.

**Jeanna Trubers.**—Manufacturers of Diamond  
Mountings, 1 Maiden Lane.

**Leber & Vorpahl.**—Manufacturers of Fine  
Diamond Mountings, Diamonds a specialty. 173  
Broadway, N. Y.

**Michel, Noth.**—Manufacturer of Diamond Jew-  
elry and Diamond Mountings—52 Maiden Lane,  
New York.

**Nissen, Ludwig & Co.**—Dealers in Diamonds and  
Diamond Jewelry. No. 51 Nassau Street, New  
York, near Maiden Lane.

**Rosswog, C. & Son**—Manufacturers of Rich Dia-  
mond Goods. Nos. 5 and 7 Maiden Lane, N. Y.

**Scheer, William**—Diamond Jeweler and Manu-  
facturer of Mountings, Novelties in Artistic Jew-  
elry, 859 Broadway, near 17th St., N. Y.

**Voelker, C. T.**—Manufacturer of 18-k. Diamond  
Mountings, Diamond Jewelry and Roller Chain  
Bracelets. 189 Broadway, New York.

**Waterman & Lehmann.**—Manufacturing Jewelers  
and Dealers in Diamonds. Diamond Work, and  
Fine fancy Rings a specialty, any piece of single  
work made to order. 37 Maiden Lane, N. Y.

#### Diamond and Pearl Setter, &c.

**Danziger, H.**—Diamond and Pearl Setter, 116  
Nassau Street, (Second Floor,) Room 6, N. Y.

#### Diamond Cutters.

**Levy, Herman.**—Importer, Cutter and Polisher of  
Diamonds. 105 Fulton Street, New York.

#### Dials, &c.

**Farnsworth, C. E. & Co.**—Successors to Jno. T.  
Gold, Manufacturers and Jobbers in Fine Watch  
Dials. 81 Nassau St., N. Y.

**New York Dial Co.**—Manufacturers of Fine  
Watch Dials. Henry Abbott, Agent, No. 7  
Maiden Lane, N. Y.

#### Enameled Clock Dials and Figures.

**Caeser Bros.**—Manufacturers of Enameled Clock  
Dials, also letters and numbers for signs. 230  
and 232 East 25th Street, New York.

#### Enamelers, Etc.

**Nutt, J. D.**—Enameler on Gold, Silver, and Cop-  
per. Linen finished Buttons and Studs. Enam-  
eling in colors. 32 and 34 John Street, New  
York.

**Orr, J. C.**—Enameler on Fine Jewelry. Enameled  
in Colors. Linen Finished Buttons and Studs.  
Band Bracelets. No. 75 Nassau Street, N. Y.

**Orr, William N.**—Enameler on Fine Jewelry.  
Masonic Jewels and Badges a specialty. Linen  
Finished Work. 79 Nassau Street, Room 18,  
New York.

#### Electroplaters, &c.

**Jeandheur, F. & Son.**—Gold and Silver Electro  
Platers & Fire Gilders, coloring Etruscan and  
Gold Jewelry a specialty. 125 Fulton St.

#### Engravers—Stone Seal, Etc.

**Fackner, Edward**—Carver, Engraver and Chaser  
on Jewelry and Pencil Cases, lettering, &c., 19  
John Street.

**Holland & Gosling**—Stone Seal Engravers.  
Precious Stones inlaid and encrusted with Dia-  
monds. No. 176 Broadway, New York, (fifth  
floor per elevator). Cameos cut and repaired.

**Knapp, Chas.** Engraver, Die Sinker & Stamper for  
Jewelry purposes. Ring Shanks & superior Band  
rings, 41 Maiden Lane, N. Y.

**Park, Wm.**—The Stone Seal Engraver. Arms,  
Crests, Monograms, etc., engraved on precious  
stones, 26 John Street, New York.

**Weston, James F.**—Stone Seal Engraver and  
incuster of Precious Stones. Coats of Arms,  
Masonic, Odd Fellows, and other devices en-  
graved. 32 John Street.

#### Fancy Goods, Clocks, Bronzes, Etc.

**Hinrichs, C. F. A.**—Importer of Fancy Goods,  
Glassware, China, Clocks, Bronzes, etc. 31 Park  
Place.

**Le Boutillier & Co.**—Importers of Fancy  
Goods, Clocks, Bronzes, &c., 3 Union Square.

**Straus, L. & Sons**—Importers of Potteries, Fai-  
ences, Bisque Figures, and Rich Fancy Goods  
especially adapted for the Jewelry Trade. 40,  
42 and 44 Warren Street, New York.

**Taylor & Bro.**—Importers of French Clocks,  
Bronzes, etc. 676 Broadway, N. Y.

**Young, J. M. & Co.**—Importers of Fine Parian,  
Lava, and Bisque Statuary, Bohemian, German  
and English Fancy Goods, 37 & 39 Murray St.,  
New York.

#### Gold and Silver Cane Heads.

**Cuppia, L. A.**—Importer of Filigree Jewelry and  
Manufacturer of Silver and Gold Cane Heads and  
Novelties in Silver and Gold Jewelry. 19 Union  
Square, N. Y.

**Simons, Bro. & Co.**—Manufacturers of Gold  
Headed Canes. 611 and 613 Sansom street,  
Philadelphia.

#### Gold and Silver Plating, Etc.

**Bantle, A.**—Gold, Silver and Electro-Plating, 130  
Fulton and 89 Nassau Streets, cor. Fulton Street,  
(Room 36), N. Y. Watch Case Polishing.

#### Gold Chains, Etc.

**Beck, J. & Son,** Manufacturers of Fine Gold  
Chains and Chain Bracelets, 10 Liberty Place,  
near Maiden Lane, N. Y.

**Carter, Sloan & Co.**—Manufacturers of Fine Gold  
Chain, 15 Maiden Lane, New York.

**Dorrance, Edge & Co.**—Manufacturers of the  
Celebrated Woven Fabric Gold Chain, No. 15  
John Street.

**Kaufmann Bros.**—Manufacturers of Gold Chains,  
and Chain Bracelets, 26 John Street; Factory,  
331 and 333 Bowery, N. Y.

**Kohn, Alois & Co.**—Manufacturers of Gold Chains.  
9 Maiden Lane, N. Y.

**Nordt, Charles.**—Successor to Nordt & Schlag,  
manufacturer of Gold Chains and Chain Brace-  
lets. Jobbing and Refilling Old Chains promptly  
attended to. No. 17 Maiden Lane, N. Y.

**Saxton, Smith & Co.**—Manufacturers of Fine  
Gold Chain, No. 14 John Street, N. Y.

**Schlag, Chas.**—Late Nordt & Schlag, Manu-  
facturer of Gold Chains, Chain Bracelets, and Fine  
Jewelry, 177 Broadway, N. Y.

**Smith, W. & Co.**—Manufacturers of Gold and  
Silver Chains, Jewelry, etc. No. 25 Maiden  
Lane, N. Y.

#### Gold Pens, Etc.

**Aikin, Lambert & Co.**—Manufacturers of Choice  
Gold Pens, Cases, Holders, Toothpicks, etc., 23  
Maiden Lane, N. Y.

**Faber, Eberhard.**—Manufacturer of 16-karat Gold  
Pens and Pencil Cases, Nos. 718 and 720 Broad-  
way, N. Y.

**Fairchild, Leroy W.**—Manufacturer of Gold  
Pens, Pencil Cases, Tooth Picks and Novelties in  
Charms. No. 18 John St., N. Y.

**Gerow, Joseph U.**—Manufacturer of Pencil and  
Pen Cases for the Jobbing Trade only. No. 44  
State Street, (near South Ferry,) Brooklyn, N. Y.

**Hicks, W. S.**—Established 1848. Manufacturer  
of Fine Gold Pens, Pencil Cases, Tooth Picks,  
and Charm Novelties of every description. No.  
20 Maiden Lane.

**Johnson, E. S. & Co.**—Manufacturers of Gold Pens,  
Pen Holders and Pencils. Cor. Maiden Lane  
and Nassau Street, New York.

**Ray Manufacturing Co.**—Gold Pens Manu-  
factured and Stamped for the Trade. Also Pencil  
and Pen Cases, Tooth-picks, etc. Office, Sales-  
rooms and Factories, 94 and 96 Nassau street,  
129, 131 and 133 Fulton street.

**Smith, H. M. & Co.**—Manufacturers of Gold Pens  
and Holders, Tooth Picks, Pencils, etc. Sole  
Manufacturers of Sprague's Patent Gold Foun-  
tain Pen. Importers of Nickel and Silver Watches.  
173 Broadway, New York.

#### Gold Rings.

**Barnet Bros. & Powell**—Manufacturers of Stone  
and Seal Rings, 15 John Street, New York.  
Factory, Newark, N. J.

**Bowden, J. B. & Co.**—Manufacturing Jeweler.—  
Solid Gold Rings a specialty, 1 Maiden Lane.

**Cable, Geo. W.**—Manufacturing Jeweler. Plain  
and Band Rings a Specialty. No. 104 Fulton  
Street, N. Y.

**Ely, W. H.**—Manufacturer of Solid Gold Rings of  
every description. No. 58 Nassau Street.

**Henrich, R.**—No. 35 Maiden Lane, Manu-  
facturer of Gold Rings; also Patentee and Manu-  
facturer of the Celebrated Self-Sizing Ring.

**Hutchison & Huestis**—Makers of Solid Gold  
Rings. Quality guaranteed. For the Jobbing  
Trade only. 106 Broadway, N. Y.

**Kroll, H.**—Manufacturing Jeweler. 78 Nassau Street, New York. Specialty: Solid Gold Stone Rings. All kinds of Fine Jewelry made to order, also Repairing for the Trade.

**Ostby & Barton**—Manufacturers of Plain and Engraved Solid Gold Band Rings. Office, 176 Broadway, N. Y. Factory, 80 Clifford Street, Providence, R. I.

**Peckham, Wm. H.**—Manufacturers of Solid Gold Seamless Rings, and Fancy Embossed Rings, Patent Spectacles, Jewelry, etc. No. 4 Liberty Place N. Y.

**Radler, K.**—Manufacturing Jeweler. Gold Rings and Lockets a specialty. No. 39 Maiden Lane, New York.

**Sauter, L.**—No. 1 Maiden Lane, New York, Manufacturer of Stone Rings of every description, as Diamond, Cameo, Onyx Turquoise, etc., Scarf Pins, Scarf Rings, Studs and Buttons.

**Shafer & Douglass.**—Manufacturers of all kinds of Seal, Stone, Turquoise, and fancy rings. No. 7 Maiden Lane, N. Y.

**Sinnock & Sherrill.**—Manufacturers of Stone Rings. No. 3 Maiden Lane, N. Y.

**Thuernert & Church**—Manufacturers of Fine Gold Rings. No. 9 Maiden Lane, N. Y.

**Wood, J. R.**—Gold Ring Manufacturer of 14 John Street, has assumed his son into partnership. The firm will now be J. R. Wood & Son.

#### Hair Jewelry.

**Moutoux, Wm. E. & Co.**—Manufacturers of Fine Hair Mountings in Gold. Grand catalogues for the trade. 81 Nassau St., Rooms 1 and 2. Finest work and lowest prices

**Sauter, L.**—Manufacturer of Fine Gold and Hair Jewelry and Device Work. Pattern Book sent on application. No. 1 Maiden Lane, N. Y.

**Schwencke O.**—Manufacturer of Fine Hair Jewelry Orders from the country promptly attended to. No. 43 Maiden Lane.

#### Jewelry Cases, Fancy Boxes, Etc.

**American Morocco Case Co.**—7 and 9 Bond St., N. Y., make a specialty of Rich Jewelry and Silverware Cases for the fine Retail Trade. Also Improved Trays for Watches, Rings, etc.

**Bleyler, A.**—Manufacturer of Jewelry and Silverware Boxes, Jewelers' Traveling Cases, etc. Trays for Show Cases and Trunks, Ladies' and Gent's Jewel, Glove and Handkerchief Boxes, &c., &c., 80 Nassau street, N. Y.

**Braun, Chr. E.**—Manufacturer of Fine Jewelry Boxes and Trays for Show Cases and Trunks. No. 62 Chatham Street, New York. Trays for Show Cases and Trunks a Specialty.

**Bricka, C. A.**—Manufacturer of Morocco Cases for Cutlery, Silverware, Jewelry, etc. Sample Cards and Rolls. Cases in Rosewood, Black Walnut, etc. 52 Nassau Street, New York.

**Dennison Mfg Co.**—Manufacturers of Morocco, Plush and Velvet Jewelry and Silverware cases. New York, Boston, Philadelphia, Chicago, Cincinnati and St. Louis.

**Ettlinger, L. & Sons.**—Manufacturers of Fine Cases for Jewelry, Watches and Silverware. Trays for Travelers and Show Cases. Cases to Order a Specialty. No. 80 Nassau St., N. Y.

**Haensler, Chas. C.**—Manufacturer of Fine Morocco Cases for Jewelry and Silverware. Toilet Boxes, etc. Trays for Show Cases and Windows. 14 John Street, New York.

**Jackson, S. C.**, 180 Broadway, N. Y., Manufacturer of Fine Cases for Jewelry, Silverware, &c.

**Kohn, Solomon & Co.**—Manufacturers of Fine Morocco Cases for Jewelry, Watches, etc. 43 Maiden Lane, New York.

**Lauten, Edw. A. & Co.**—No. 4 Great Jones St., Manufacturers of Fine Velvet, Brocade, Plush and Morocco Boxes, Patent Ring, Ear Ring and Gent's Scarf Pin Trays, Patent Watch and Bracelet Blocks, Window Decorations, etc.

**Metropolitan Fancy Box and Leather Goods Manufacturing**—Makers of Plush, Velvet, Satin and Leather Cases for Watches, Jewelry, Silverware, etc. 75 and 77 Nassau Street, N. Y.

**New England Morocco Case Co.**—Makers of Jewelry and Silverware Cases of every description. 220 Chapel Street, New Haven, Conn.

**New York Morocco Case Co.**—Cases for Jewelry, Watches, Silverware. Boxes and Trays for Jewelers' Travelers. Show Cases and Window Fittings. No. 69 Nassau Street, New York.

**Sauer & Schroeter**—Successors to Loehr & Koerner, Manufacturers of Morocco, Velvet, Satin, Jewelry, Watches and Silverware Cases, Jewel Work Boxes, etc., Fancy Trays and Store Fittings to order. 96 Liberty St.

**Schwarz, N.**—Manufacturer of fine Cases for Jewelry and Silverware, 866 Broadway, near 17th street, N. Y.

**Steinle, E.**—Manufacturer of Cases for Jewelry of all kinds. Also Cases for Mathematical and Surgical Instruments and for Trays for Travelers' Trunks, etc. 66 Nassau Street, N. Y.

**Welch & Miller**—169 Broadway. Manufacturers of fine Morocco, Velvet, Russia, Brocade and Plush Jewelry Cases. Trays of every description; Jeweler's Cotton and Twine.

**Wiggers & Froelich**—No. 60 Nassau street—Manufacturers of Cases for Jewelry, &c., of every description. Trays for Show-cases, Stands for Show-windows, etc.

#### Jewelers' Findings.

**Dennison Mfg Co.**—Paper Jewelry Boxes, cards, tags, pink and white cotton, etc. etc. New York, Boston, Chicago, Cincinnati, Philadelphia, St. Louis.

**Ettlinger, L. & Sons.**—Manufacturers of Jewelers' Paper Boxes and Findings. Morocco Paper, Satin or Plush Lined Wooden Corner Stops Jewelry and Silverware Boxes. 80 Nassau Street, New York.

**Lehmann, Ludwig**—Manufacturer of Jewelers' Findings. Specialty, Fine Paper Boxes for Jewelers and Silversmiths, 122 Fulton St., N.Y. City.

**Valfer, S. & Co.**—Manufacturers and Dealers in Jewelers' Boxes, Tags, Cards, Paper and Findings. Trays a specialty. Office and Salesroom, 66 Nassau street, New York.

#### Jewelry Manufacturers.

**Aikin, Lambert & Co.**—Manufacturers General stock of Reliable Jewelry, 23 Maiden Lane.

**Alling, Isaac A. & Co.**—Manufacturers of Fine Gold Jewelry. Sets, Lace Pins, Ear Rings, Studs, Collar Buttons and Scarf Pins. Specialties: Wire Bracelets, Bangles, American Lever Sleeve Buttons. Bryant Building, Nassau and Liberty Streets, N. Y. Factory, Newark, N. J.

**Ball, W. H.**—Manufacturer of Gold Jewelry. Bracelets and Bangles of all kinds a specialty. 9 John Street, N. Y.

**Barthman, Straat & Co.**—Manufacturers of Fine Jewelry. Roman Goods, Rings, Diamonds. No. 43 Maiden Lane.

**Bissinger, Philip & Co.**—Importers of Diamonds, Pearls and Precious Stones. Sole Agents for the Bohemian Garnet Jewelry, Blue Enameled Lockets. 22 John St., N. Y.

**Brown, Thos. G. & Sons**—Manfrs of Rich Jewelry Necklaces, Lockets, Bracelets, Sleeve Buttons, etc., 5 Bond Street, N. Y.

**Bryant & Bentley**—Manufacturing Jewelers. Rings a specialty. 12 Maiden Lane

**Carter, Sloan & Co.**—Manufacturing Jewelers, 15 Maiden Lane, New York.

**Champerois & Co.**—No. 5 Maiden Lane, manufacturers of Engraved and Enameled Gold goods, in Sets, Ear Knobs, Bracelets, Studs, Lace and Shawl Pins, Jet cluster and Onyx goods, also "Best Lever" Sleeve Buttons.

**Chatellier, Joseph F.**—Manufacturing Jeweler, No. 694 Broadway, N. Y.

**Churchill, Lewis & Co.**—Manufacturers of Fine Jewelry. 692 Broadway, cor. Fourth St., N. Y.

**Cook, George W.**—Manufacturer of Fine Jewelry and Lockets, 191 Broadway (over Mercantile Bank,) N. Y.

**Cottle S. Co.**—Manufacturers of Fine Jewelry. Waltham Building, 5 Bond Street, N. Y.

**Cox & Sedgwick**—Manufacturers of fine Onyx and Colored Jewelry. 26 John St., New York

**Day & Clark**—Manufacturers of Fine Jewelry, Lace Pins, Ear Rings, Studs, Lockets, &c., 10 Maiden Lane, New York.

**Geoffroy, Arthur R. & Co.**—Manufacturing Jewelers. Novelties in Diamond Goods. No. 23 Maiden Lane, N. Y.

**Greene Wm. C. & Co.**—Goldsmiths; Manufacturers of Rich Sets in Taper Wire Coral, Office, 193 Broadway,

**Griffith, H.**—Manufacturing Jeweler. Gold and Plated Jewelry. Scarf Pins a specialty. Nutry Alley, near Concord St., Brooklyn, N. Y.

**Groeschel & Rosman**—Manufacturers of Fine Jewelry. No. 27 John Street, N. Y.

**Hale, S. W. & Co.**—Manufacturers Rich Jewelry, Whiting Building, Broadway and 4th Street.

**Hartmann, P.**—Manufacturer & Importer of Fine Gold, Diamond, and Filigree Silver Jewelry, No. 36 Maiden Lane. P. O. Box 2,454.

**Hedges, A. J. & Co.**—Manufacturing Jewelers, 6 Maiden Lane.

**Henderson & Winter**—Jewelers, No. 15 Maiden Lane, New York. Specialties—Stone, Cameo, Onyx, Amethyst, Topaz, Pearl and Turquoise Rings.

**Howard & Scherrieble**—Manufacturers of the American Lever Sleeve Button. 178 Broadway.

**Hunt & Owen.**—Manufacturing Jewelers. Office 3 Maiden Lane.

**Kremetz & Co.**—Manufacturing Jewelers, No. 182 Broadway, N. Y.

**Kuhn, Doerflinger & Co.**—Manufacturers of Enamelled and Roman Band Bracelets, also Fine Lockets Pendants and Lace Pins. 18 John street.

**Miller Bros.**—Manufacturers of Fine Jewelry, Lockets, Sleeve Buttons, Studs, &c., 7 Maiden Lane, N. Y.

**Moore & Horton**—11 Maiden Lane, Manufacturing Jewelers, Rings, Studs, Collars and Sleeve Buttons, Pins, Ear-rings, &c.

**Muhr's, H., Sons.**—Manufacturing Jewelers. Solid Gold and Filled Rings a specialty. Also Manufacturers of the celebrated Crown Filled Watch Case. 16 Maiden Lane, N. Y.

**Owen, G. & S. & Co.**—Manufacturing Jewelers. Office, No. 3 Maiden Lane.

**Richardson, Enos & Co.**—Manufacturers of Fine Gold Jewelry, Gold Chains, Lockets, Crosses and Necklaces. Colored and Etruscan Work. No. 23 Maiden Lane, New York.

**Richardson, J. W. & Co.**—Manufacturers of Jewelry. Masonic and other Emblems. 196 Broadway, N. Y. Manufactory, Providence, R. I.

**Riley, J. A. & Co.**—Manufacturing Jewelers Etruscan Gold and Roman Bracelets, Lace Pins, Ear Rings, Scarf Pins, Brooch Pins, etc. Nos. 7 and 9 Bond Street, N. Y.

**Ripley, Howland & Co.**—Manufacturers of Fine Jewelry and Platinum Tipped Diamond Settings. No. 17 Maiden Lane, N. Y.

**Sauter, L.**—Manufacturer of Fine Jewelry, Solid Stone Rings and Studs a specialty. Jobbing for the trade. 1 Maiden Lane, New York.

**Schwencke, Wm.**—Manufacturing and Jobbing Jeweler. Repairing a specialty. Orders promptly attended to. No. 43 Maiden Lane, N. Y.

**Sexton & Cole**—Manufacturing Jewelers, Colored Gold and Onyx Goods a specialty. No. 30 Maiden Lane.

**Shafer & Douglas,** Manufacturing Jewelers—Roman Goods, Lace Pins, Cameo Sets, etc., Stone Rings, etc. No. 7 Maiden Lane, N. Y.

**Sheafer, W. H. & Co.**—Manufacturing Jewelers, Specialty Bangles and Bracelets, 15 John St., N.Y.

**Stites' Sons, E.**—Manufacturers of Fine Jewelry. No. 14 John Street, N. Y.

**Street, Geo. O. & Sons.**—Established 1837. Makers of Fine Jewelry, strictly first-class goods of our own make. No. 15 John Street, New York.

**Thoma, Ernest**—Manufacturer of Fine Jewelry, Sleeve Buttons, Rings, Ear-rings, &c. No. 173 Broadway, N. Y. Factory, Haelenack, N. I.

**Ward, Thos. M.**—Manufacturer of Fine Jewelry, Diamond Mountings a specialty. No. 25 John Street, N. Y.

**Wienhold, Joseph**—Manufacturer of Fine Jewelry Diamond Mountings a specialty. 24 John St.

**Wogom & Miller**—Manufacturers of Black Onyx Goods exclusively. 32 & 34 John Street, N. Y.

#### Jewelry—Rolled Plate.

**Blackinton, W. & S.**—Manufacturers of the W. & S. B. Rolled Plated Chains. No. 11 Maiden Lane.

**Frick, John & Co.**—Fine Rolled Plate Jewelry of all kinds. Repairing of every description. 21 and 23 Maiden Lane, N. Y.

**Mauran, J. T.**—Manufacturer of Fine Rolled Plate Jewelry, No. 15 Maiden Lane, N. Y.

**Richards, E. Ira & Co.**—Manufacturers of Fine Rolled Plate Jewelry, No. 200 Broadway, N. Y.,

**Jewelers' Tools, etc.**

- Fisher, James J.**—Dealer in Watchmakers' and Jewelers' Materials, Files, Tools, Silk Guards Spectacles, etc. 697 Broadway, N. Y.
- Friedenthal, A. & Co.**—Importers and jobbers of Watchmakers' and Jewelers' Tools, Materials, etc. 43 Maiden Lane, N. Y.
- Friedlander, R. & L.**—Importers of Watchmakers' Tools and Materials. 65 & 67 Nassau Street. Branch Office, 264 Bowery.
- Kurtz, F. P.**—Manufacturer of Jewelers Machinery, Tools, Rolling Mills, Presses, Polishing Lathes, &c. 97 Cliff St., N. Y.
- Levy, Dreyfus & Co.**—Importers and Jobbers of Watchmakers' and Jewelers' tools and materials of every description. 11 Maiden Lane, N. Y.
- Montgomery & Co.**—Importers of and Dealers in Manufacturing Jewelers' Tools and Materials of every description, 105 Fulton street, New York.
- Reichhelm & Koester.**—Importers of Jewelers' Tools, Files, etc. Manufacturers of Brushes and Buffing wheels; also Patent Gas Furnaces for Melting, Plating, Enamelling, Annealing, etc. 80 Nassau St., N. Y.

**Lapidaries.**

- Fox, M. & Co.**—Practical Lapidaries, No. 1 Maiden Lane, New York.
- Graham & Co.**—Practical Lapidaries, Cutters and Polishers of all kinds of Precious Stones. Miners' Relics Cut, Polished and Mounted. Miniature, Locket and Clock Glasses. 80 Nassau St., N. Y.
- Kordmann & Michel.**—Lapidaries. Dealers in Precious Stones. Cutting and Polishing Rubies, Sapphires and other Gems a specialty. Drilling done promptly. 59 Nassau St., N. Y.
- Korn, Ph.**—Lapidary. Importer of Precious and Imitation Stones, No. 63 Nassau street, between Maiden Lane and John street, New York.

**Masonic Jewelry.**

- Luther, John F.**—79 Nassau Street. Manufacturer of Fine Presentation Jewels for all Societies. Knights Templars, Crosses, Badges, &c.
- Popper, H.**—Manufacturer of Medals and Badges for Military, G. A. R., Shooting, Masonic, Odd Fellows, Knights of Pythias, etc. 91 Essex St., New York.
- Wilkinson, C. B.**—Manufacturing Jeweler, 8 John St., N. Y. Medals, Badges and Masonic Jewelry, a specialty. Designs furnished free upon application.

**Musical Instruments.**

- Stratton, Jno. F. & Co.**—Importers and Wholesale Dealers in all kinds of Musical Merchandise, Music Boxes, Musical Novelties, etc. 49 Maiden Lane, N. Y.

**Optical Goods.**

- Friedlander, R. & L.**—65 and 67 Nassau Street. Dealers in Optical Goods.

**Opticians.**

- Burbank Manf'g Co.**—Manufacturers of Spectacles and Eye Glasses of all descriptions, in gold, silver, etc., 14 Maiden Lane, N. Y.
- DuBois, Geo. W. & Co.**—Importers of Watches and Optical Goods. 36 Maiden Lane, N. Y.
- Kahn, Hanover & Co.**—Importers of Spectacles, Eye-Glasses and Optical Goods generally, and Scientific Instruments of every description. 32 Maiden Lane, New York.
- Levy, Dreyfus & Co.**—Importers of Spectacles and Eye Glasses and Optical Instruments of every description, No. 11 Maiden Lane, N. Y.
- Lorsch, Albert**—Manufacturer of the Patent Accommodating Spectacles and Eye Glasses in Gold, Silver and Steel, and other Optical Goods, 37 Maiden Lane, N. Y.
- Spencer Optical Manufacturing Co.**—Gold, Silver, Steel, Nickel and Plated Spectacles; Gold, Celluloid, Steel, Nickel and Rubber Eye Glass and Opera Glasses. 13 Maiden Lane, N. Y.

**Paper Boxes.**

- Waterbury Paper and Box Co.**, 27 to 35 Canal St., Waterbury, Conn., Manufacture Jewelers' and Silversmiths' Fine Paper Boxes. Quality guaranteed to be equal to the best made.

**Precious Stones, &c.**

- Bishop, Victor & Co.**—33 Maiden Lane, Importers of Precious Stones, Cameos, &c. Also Manufacturers of Coral Jewelry.
- Bissinger, Philip & Co.**—Importer of Diamonds, Pearls and Precious Stones. Agent for the Bohemian Garnet Goods. Blue Enamelled Locketts. No. 22 John St., N. Y.
- Breidenbach, R. A.**—Importer of Black Onyx, Cameos, Turquoise, Pearls, Sardonyx, Amethysts, Topaz, Garnets, Opals, Rubies, Sapphires, Cat's Eyes, Hematites, Brilliants, Doublets, etc. 85 Nassau St., N. Y.
- Daue, Wm. & Co.**—Importer of Precious and Imitation Stones. No. 202 Broadway New York.
- Fox, M. & Co.**—Importers of Diamonds and other Precious Stones, No. 1 Maiden Lane, N. Y.
- Gruet, Jules.**—Importer of all Grades of Real and Imitation Stones. 14 John St., N. Y.
- Guntzburger Bros.**—Manufacturers and importers of Precious Stones—Amethysts, Topaz, Cameos, Garnets, Imitation Diamonds, &c. No. 9 Maiden Lane.
- Hahn & Co.**—Importers of Precious Stones. Cameos, Onyx, Pearls, Intaglios, Amethysts, Garnets, etc. 64 Nassau Street, New York.
- Kahn, L. & M.**—Importers of precious and imitation stones. 10 Maiden Lane, N. Y.
- Kipling, E. E.**—Importer of Precious and Imitation Stones. Manufacturer of the Patent Foil Solid Metal Back Rhine Stone Brilliant. No. 6 Maiden Lane, N. Y.
- Kipling, R. A.**—Precious and Imitation Stones, No. 24 Maiden Lane, N. Y. Manufacturer Cameos, Agates, Onyx, Etc., Oberstein, Germany. Commission Merchant, 49 Rue De L'Echiquier, Paris.
- Lorsch, Albert**—Importer of Precious Stones, 37 Maiden Lane, N. Y.
- Tannenbaum, L. & Co.**—Importers of Diamonds and Precious Stones. Steam Lapidary Works. Oriental Stones Cut and Polished a specialty. 65 Nassau St., N. Y.

**Safes.**

- Butler, W. H.**—Fire and Burglar Proof Safes, 291 Broadway, N. Y.

**Silverware.**

- Gorham Manufacturing Co.**—Union Square.
- Knowles, J. B. & S. M.**—Manufacturers of Sterling Silverware, 20 Maiden Lane, N. Y. Factory, Providence, R. I.
- Shiebler, Geo. W.**—Manufacturer of Sterling Silverware. No. 8 Liberty Place, near Maiden Lane, N. Y.
- Whiting Manufacturing Co.**—Makers of Sterling Silver Ware. Broadway cor. 4th Street, N. Y.
- Wood & Hughes.**—Manufacturers of Fine Silverware. 16 John Street, N. Y.

**Silver Filigree Jewelry.**

- Cuppia, L. A.**—Manufacturer of Solid Silver Novelties, and Importer of Silver Filigree, 19 Union Square.
- Francesconi, Guido**—Importer of Silver Filigree Jewelry, 196 Broadway, New York.
- Hartmann, P.**—Manufacturer of Silver Filigree Jewelry. 36 Maiden Lane, N. Y.

**Silver Plated Ware.**

- Hartford Silver Plate Co.**—Manufacturers of Fine Electro-Plated Ware. Factory and Salesroom, 28 High Street, Hartford, Conn.
- Holmes, Booth & Haydens**—Manufacturers of Silver-Plated Ware. 47 Chambers Street.
- Manhattan Silver Plate Co.**—Manufacturers of Silver Plated Ware. Showrooms, 23 John St. Factory, 301 to 305 East 22d St., cor. 2d Ave. Address all communications to Factory.
- Middletown Plate Co.**—Manufacturers of Superior Electro-Plate. Factories, Middletown, Conn., salesroom, 13 John Street.
- Rogers & Bro**—Manufacturers of the finest quality of Electro-Plated Ware. 690 Broadway.
- Rogers, Smith & Co.**—Manufacturers of Fine Electro Plated Ware. No. 46 E. 14th St., N. Y.
- Simpson, Hall, Miller & Co.**—Manufacturers of fine Silver-Plated Ware. No. 36 E. 14th Street.

**Schade, Henry.**—Manufacturer of White Metal and Plated Ware. Nos. 56 & 58 Ainslie Street, Brooklyn, E. D., N. Y. Price list and catalogue furnished on application.

**The Derby Silver Co.**—Manufacturers of Finest Quadruple Silver Plated Ware, Birmingham, Conn. New York office, 25 Maiden Lane.

**Webster, E. G. & Bro.**—Manufacturers of Fine Silver-Plated Ware. Office and warerooms, 14 Maiden Lane, N. Y.

**Show Cases, Etc.**

**Smith, B. & W. B.**—Manufacturers of Patent Improved Dust Proof Show Cases, with Perpendicular Sliding Doors, No. 220 W. 29th St., N. Y.

**Spectacle Case Manufacturers.**

- Bertine, P. D.**—Manufacturer of Spectacle and Eye-Glass Cases. 139 William Street, near Fulton St., New York.
- Koenen, A. & Bro.**—Manufacturers of Leather Spectacle and Eye-Glass Cases for the Jobbing Trade only. 81 Nassau St., N. Y.

**Stem Winding Attachments.**

**Abbott, Henry** Maker of Stem Winding Attachments, No. 7 Maiden Lane, N. Y.

**Thermometers, Etc.**

**Tagliabue, Giuseppe.**—Manufacturer of Thermometers, Barometers and Hydrometers. Patentee and sole manufacturer of the U. S. Standard Hydrometer. 302 Pearl Street, near Beekman.

**Thimble Manufacturers.**

- Barker Manuf'g Co.**—Makers of Patent Graduated Thimbles, Stiffened Gold, Filled Gold and Rolled Gold, 36 Maiden Lane, N. Y. A. Lyons, Ag't. Factory, 129 Eddy St., Providence, R. I.
- Burbank Manuf'g Co.**—Manufacturers of Gold and Silver Thimbles, 14 Maiden Lane, N. Y.
- Ketcham & McDougall.**—Improved Gold and Silver Thimbles, Bryant Building, N. Y.
- Simons Bro. & Co.**—Manufacturers of Gold and Silver Thimbles. 611 and 613 Sansom Street, Philadelphia.
- Woglom & Miller.**—Sole Agents for the "Prime" Thimbles in Gold and Silver, manufactured by Ezra C. Prime. 34 John Street, N. Y.

**Trunks.**

**Crouch & Fitzgerald**—Manufacturers of Trunks and Articles for Travelers' use. 1 Cortlandt St., 556 Broadway, and 723 Sixth Ave., N. Y.

**Watch Companies.**

- American Watch Co.**—Robbins & Appleton, No. 5 Bond Street, N. Y.
- The E. Howard Watch and Clock Co.**—Cor. Maiden Lane and Nassau Street, N. Y.
- Waterbury Watch Co.**—Manufacturers of the Waterbury Watch. Factory, Waterbury. Office, 52 Maiden Lane, N. Y.

**Watch and Chronometer Jeweler.**

- Queen, James.**—Watch and Chronometer Jeweler and Pallet Maker, 78 Nassau Street, room 8. Pivots inserted in Pinions, Balance, Staffs, etc.
- Robert, Henry L.**—Practical Chronometer and Watch Jeweler, and Adjuster of all kinds of Escapements. 71 Nassau Street (Room No. 3). All kinds of Pallet and Hole Jewels for Chronometer Watches and Compasses done in the best manner.
- Wenstrom, John.**—Watch, Chronometer and Clock Jeweler, Jewel Gauges, Ruby and Sapphire Draw Plates; Diamond Charged Polishing Stones for Jewel Settings; Pivots inserted in Pinions, 2 Dutch Street, N. Y.

**Watch Importers, Etc.**

- Abry, Chas. Leo**—Importer and Manufacturer of Swiss Watches of all grades. 63 Nassau Street.
- Aikin, Lambert & Co.**—Importers of Watches. Sole Agents for Paul Breton & Chas. Latour, Geneva. A general line of reliable Swiss Watches, Watch Cases, etc. 23 Maiden Lane, N. Y.
- Bartens & Rice**—20 John Street, Importers of Watches and sole agents in the United States for the celebrated Nicole, Nielsen & Co. Watches.

**Cross & Beguelin.**—Importers of Watches, Watch Tools and Materials, dealers in American Watches, No. 21 Maiden Lane, N. Y.

**Droz, Henry E.**—Importer of Watches, and Watch Case Manufacturer. Agent for the "E. Perre-gaux" Watch, and jobber in American Watches No. 92 Fulton Street, N. Y.

**Freund Max & Co.**—Importers of Watches, Jew-elry and Precious Stones, 8 Maiden Lane, N. Y.

**Gagnebin, Chas.**—Importer of all kinds of Swiss, and Dealer in American Watches. 4 Maiden Lane, N. Y. Agent for Ulysse Breting's Fine Chronometers, Chronographs, Anchors, &c.

**Gallet, Julien.**—Importer of Watches. No. 1 Maiden Lane.

**Ginnel, Henry**—Importer of Watches, Tools and Materials, 31 Maiden Lane, N. Y. P. O. Box 2967

**Hyde's Sons, John E.**—Wholesale Commission Agents, only for Jules Jurgensen, of Copenhagen; Jules Monard, of Geneva; and for other makers of all qualities of Watches, 22 Maiden Lane.

**Keller, L. H. & Co.**—Successors to G. A. Hugue-nin, Importers of Fine Watch and French Clock Materials, No. 64 Nassau Street, N. Y.

**Mathey Bros. & Mathez.**—Importers of Fine Watches and Sole Agents for the H. L. Matile's Watches. No. 16 Maiden Lane.

**Robert, J. Eugene**—No. 30 Maiden Lane, New York. Agent for Louis Audemar's celebrated watches.

**Schumann, Chas. W.**—No. 24 John Street, New York. Importer of Fine Diamonds, Watches, etc. Sole Agent in the U. S. for the celebrated "Lange" Dresden Watch, also Sole Licensee for Trenor's Differential Dial.

**Schwob, Adolphe**—Manufacturer and Importer of Watches, 11 Maiden Lane, N. Y.

**Strasburger, Louis & Co.**—Importers and Makers of Watches of every description, 15 Maiden Lane.

#### Watch Cases.

**Dueber Watch Case Mfg Co.**—Manufacturers of Gold and Silver Watch Cases. Bryant Building, N. Y. Factory, Newport, Ky.

**Duhme & Co.**—Manufacturers of Gold and Silver Watch Cases. Carlisle Block, Fourth and Walnut Streets, Cincinnati.

**Fahys, Joseph**—Manufacturer of Watch Cases and Dealer in American Movements, 38 Maiden Lane.

**Glatz, Chas.**—Manufacturer of Silver Watch Cases. Bryant Building, cor. Nassau and Liberty Sts.

**Keller & Untermeyer.**—Manufacturers of Watch Cases with Raised Gold Ornaments. 9 Maiden Lane, N. Y.

**Ladd Watch Case Co.**—Manufacturers of the Ladd Patent Stiffened Gold Watch Cases, etc., 11 Maiden Lane, N. Y. Factory, 58 Eddy Street, Providence, R. I.

**The Brooklyn Watch Case Co.**—Manufacturers of the celebrated Eagle Case. 40 Maiden Lane.

**Willemin Watch Case Co.**—Makers of Gold Watch Cases. Raised Gold Ornamentation and Jurgensen style of Engine Turning. 109 Sands Street, Brooklyn, N. Y. 16 Maiden Lane, N. Y.

#### Watch and Chronometer Repairers.

**Cerf, B.**—Practical Watchmaker and Repairer, No. 10 John Street, N. Y. Repairing and adjusting of Fine Watches done for the trade. All kinds of escape and stem-winding wheels cut to order.

**Goepf, Frederick A.**—Practical Watchmaker. Repairing of every description for the Trade. 25 Maiden Lane, N. Y. In office of H. Garland, Engraver.

**Heinrich, H. H. & Co.**—Sole Manufacturers of H. H. Heinrich's Patent Auxiliary Balance, and Adjusters and Repairers of Fine Watches and Chronometers. 12 John Street, N. Y.

**La Croix, J. H.**—(Late with Benedict's Time,) Watch and Clock Maker, 21 John Street, N. Y. Clocks of every description Repaired for the Trade.

**Lesperance, Theo.**—Watchmaker and Wheel Cutter. Also Stoning Nickel Movements. No. 1 Maiden Lane, New York. With Julien Gallet.

**Ludeman, W. H.**—Chronometer and Watch Maker. Repairing of every description for the trade, 75 and 77 Nassau Street.

#### Watch Case Repairers.

**Feinier, Joseph A.**—Watch Case Maker and General Repairer. Specialty in fine Gold and Silver Cases. Jobbing promptly attended to. Nos. 4 and 6 John St., N. Y.

**Tarbox, Hiram**—Watch Case Repairing, Springing, Polishing and Engine Turning. 1874 North Fourth Avenue, bet. 176th and 177th Sts., N. Y. Express Packages should be sent to 92 Fulton Street.

#### Watch Glasses, Shades, Etc.

**Brown, Edwin H.**—No. 85 Nassau Street, Imported and Own Manufacture Watch Glasses, Flat, Flat Concave, Concave, Convex and fine Geneva's, Fine fitting solicited.

#### Watches, Diamonds and Jewelry.

**Alford, C. G. & Co.**—Manufacturers. General line fine and Reliable Goods. Specialties in Onyx Goods and Chain. 200 Broadway, New York.

**Cohn, J. J.**—Importer and Manufacturer of Whitby Jet, Rubber and Pearl goods. Gold and Rolled-plate Jewelry, etc. 12 Maiden Lane, New York.

**Durfey & Reynolds**—Successors to Durfey & Shiebler, Watches, Diamonds, Jewelry. No. 9 John Street, (up-stairs) New York.

**Friedman, Saml.**—Wholesale Dealer in Watches and Jewelry, 42 Maiden Lane, N. Y.

**Goddard, John M.**—Manufacturing Jeweler,— Seal Rings and Fine Locketts a specialty, No. 3 Maiden Lane, N. Y.

**Greason J. R. & Co.**—Successors to Arthur, Rum-rill & Co., 182 Broadway. Manufacturers of Fine Jewelry and Gold Chains, also Diamond Mount-ings.

**Haskell, H. C.**—Manufacturing Jeweler. Seal Rings a specialty. Special attention to Jobbing of every description. 12 John street.

**Herzog, Louis & Co.**—Importers of Watches, Dealers in Diamonds and Jewelry, 52 Maiden Lane, N. Y.

**Hirsch Bros.**—Dealers in Watches and Diamonds and Manufacturers of Jewelry, No. 23 Maiden Lane, N. Y.

**Jandorf, P. & Bro.**—Importers of Watches and Jewelry, 196 Broadway.

**Kennedy, Frank S.**—Manufacturer and Wholesale Dealer in Jewelry and Gold and Silver Thimbles. No. 13 Maiden Lane, New York.

**Lissauer & Sondheim**—Wholesale Jewelers and Jobbers in American Watches, No. 12 Maiden Lane, N. Y.

**Marx, Kossuth & Co.**—Importers of Watches and Dealers in Jewelry. 39 Maiden Lane, N. Y.

**Mayer, B.**—Manufacturer of Fine Jewelry, and Dealer in Watches, 71 Nassau street, cor. John street, New York.

**Myers, S. F. & Co.**—Manufacturing and Whole-sale Jewelers—all grades. Importers of Watches. Illustrated Catalogue to the trade. 179 Broad-way, N. Y.

**Oppenheimer Bros. & Veith,**—Dealers in Watches and Diamonds, and Manufacturing Jewelers, No. 35 Maiden Lane.

**Scott, J. T. & Co.**—Importers of Watches, and Manufacturers of Jewelry, and Jobbers of all Grades of American Watches, 11 Maiden Lane.

**Smith & Knapp**—Wholesale Dealers in American and Swiss Watches, Diamonds, Gold and Plated Jewelry and Gold Chain. 182 Broadway, N. Y.

**Steele, J. W.**—Successor to Brainerd, Steele & Co., Manufacturer of Fine Jewelry and Brainerd's Patent Locketts. No. 9 Maiden Lane, N. Y.

**Stern Brothers & Co.**—Importers of Swiss Watches and wholesale dealers in American Watches, &c., 39 Maiden Lane.

**Stern & Stern**—Dealers in Watches, Jewelry and Diamonds. No. 6 Maiden Lane, N. Y.

**Stites, D. H. & Son**—Manufacturers of Fine Jewelry, Rolled Plated Goods and Chains, Parisian Diamond Rings, Studs and Earrings a specialty. 41 Maiden Lane, N. Y.

**Strauss, Jacob.**—Full Line of Gold and Plated Jewelry, and Importer of Watches. 18 John Street, New York.

**Thrall, E. A.**—Wholesale Dealer in Watches and Jewelry. No. 1 Maiden Lane, N. Y.

**Trier Bros.**—Importers of Garnet, Whitby Jet and Amber Jewelry, Silk Guards, Opera, Field and Marine Glasses, Pearl Card Cases. Also a full line of Gold and Plated Jewelry. 15 Maiden Lane, N. Y.

**Wheeler, Parsons & Hays.**—Manufacturers of Fine Jewelry, Watch Cases, Gold Chains, &c. and Dealer in American and Swiss Watches, No. 2 Maiden Lane, N. Y.

**White, N. H.**—Jobber in American-Waltham Watches and Chronographs. Waltham make of 10-k., 14-k. and 18-k. Gold and Sterling Silver Cases; Filled Gold Cases. 11 Maiden Lane.

#### Watch Tools, etc.

**Keller, L. H. & Co.**—Importers of Watchmakers' and Jewelers' Tools, Materials, etc. 64 Nassau Street, N. Y.

**Zimmern, Henry**—Importer of Watch Materials, Tools, and Optical Goods, No. 8 Maiden Lane, (first floor.) Sole Agent for A. Hugenin & Gravier. Mainsprings, New York.

#### PHILADELPHIA

**Bennett, Jacob & Son,**—Diamond Setters and Manufacturing Jewelers, 925 Chestnut St.

**Bernard & Co.**—Manufacturers of Fine Roman and Etruscan Jewelry. Designs of every descrip-tion made to order, 123 & 125 South Eleventh Street, Philadelphia.

**Booz & Co.**—Manufacturers of Gold and Sil-ver Watch Cases and Jewelry, 108 South 8th St., Philadelphia.

**Conover David F. & Co.**—American Watches, Wholesale Salesroom, Southeast corner 7th and Chestnut Streets, Philadelphia.

**Herold, Chas P.**—Successor to Hildebrandt, Her-old & Co., Manufacturing Jeweler and Diamond Setter. Diamonds. 916 Chestnut Street.

**Krieder, Peter L.**—Manufacturer of Sterling Sil-ver Ware. 618 Chestnut Street, Philadelphia.

**McCall & Newman**—Manufacturing Jewelers. Makers of the Original Gold Crown Filled Rings. No. 625 Arch St., Philadelphia.

**Morgan & Headly.**—Manufacturing Jewelers. Cameo Sets, Gold Sets, Roman Locketts, Rings, Coral Sets and a general line of rich goods. Cor-ner 10th and Chestnut Streets, Philadelphia.

**Muhr's, H., Sons.**—Manufacturing Jewelers. Solid Gold and Filled Rings a specialty. 633 and 635 Chestnut Street, Philadelphia. 1½ Maiden Lane, New York.

**Peters, Reese S.**—Manufacturer of Patent Rolled Plate or Filled Watch Cases, Dealer in American Movements, 308 Chestnut Street, Philadelphia.

**Rosenthal, G. F. C.**—Manufacturing Jeweler and Diamond Setter. Engraving and Designing of Monograms a specialty. No. 917 Sansom Street.

**Scherr, L. A. & Co.**—Wholesale Dealers in Watches Silver-Plated Ware, Spectacles, Fancy Goods, Watch Materials. etc. 726 Chestnut Street,

**Sheaffer, W. H. & Co.**—Manufacturing Jewelers. Specialty: Band Bracelets. Factory, 612 and 614 Chestnut street, Philadelphia. Office, 15 John street, New York.

**Simons, Brother & Co.**—Manufacturers of Fine Jewelry, Canes, Thimbles, Chains. 611 and 613 Sansom Street.

#### CHICAGO.

**American Watch Company,**—of Waltham, Mass. No. 102 State Street, Chicago.

**Clapp & Davies**—Wholesale Jewelers, 63 and 65 Washington Street. Catalogue and price list issued to watchmakers and jewelers.

**Dennison Manufacturing Co.**—Manufacturers of Jewelers' Paper Boxes, Morocco Cases, Tags, Cards, Pink and White Cotton, Tissue Papers, Sealing Wax, &c., &c., 102 Madison St., Chicago. Boston, New York, St. Louis, and Philadelphia.

**Excelsior Sign Co.**—Manufacturers of (Grout's Excelsior) Iron Watch and Spectacle Signs. 124 Fifth Avenue, Chicago, Ills.

**Gilbert, Wm. L., Clock Co.**—Manufacturers of Clocks, Regulators, and Time Pieces, and Clock Material of every description, 54 and 56 Madison Street, Chicago.

**Giles, Bro. & Co.**—Manufacturers and Jobbers in Watches, all classes of Jewelry, Materials, Clocks, Silver Ware. &c. Illustrated catalogues furnished to dealers on application. 101 & 103 State St.

**Stein & Ellbogen**—Wholesale Dealers in Watches and Jewelry, 127 State Street, Chicago, Ill. Specialty, repairing for the trade.

**Wathier, Joseph P.**—Watchmakers and Jewelers for the trade, and Wholesale Dealers in Watch Materials, Tools, etc. 178 West Madison Street, Chicago, Ill. Send for price list.

**Wendell, Charles & Son**—Wholesale Watches, Jewelry, etc. 170 State street, Chicago.

### NEWARK.

**Baker & Co.**—Gold, Silver and Platinum Refiners, Assayers and Sweep Smelters. 408 New Jersey Railroad Avenue, cor. Murray St., Newark, N. J.

**Diefenthaler Bros. & O'Donnell**—Manufacturers of Fine Jewelry, Lace Pins, Ear Rings and Patent Spring Bangles a Specialty. 36 Crawford Street, Newark, N. J.

**English & Miller**—Manufacturers of Gold Jewelry, Diamond and Fancy Stone Rings, Roman Locketts, Bangle and Flexible Bracelets, Knife Edge Lace Pins and Sets, Scarf Pins and Link Buttons. 61 and 63 Hamilton St., Newark.

**Felger, F. & F.**—Manufacturing Jewelers. Specialties:—Roman Band Bracelets, Lace Pins, Scarf Pins, Ball and Fancy Ear Rings. No. 477 Washington Street, Newark, N. J.

**Fiedler, Herrman**—Successor to Kunze & Fiedler, Engraver, Die Sinker and Press Tool Maker, 363 Market Street, Opposite Pennsylvania R. R. Depot, Newark, N. J.

**Glorieux, W. L.**—Assayer, Refiner and Sweep Smelter. 13 and 15 Franklin Street, Newark, N. J.

**Hopper & Wilson**—Manufacturers of Fine Jewelry, No. 8 Maple Place, Rear 44 Green St., Newark, N. J.

**Hüger & Heitlinger**—Manufacturers to the Jobbing Trade only. Makers of Roman Stone, Engraved and Enameled Locketts, also Sets, Lace Pins and Ear Rings. Rear 477 Washington St.

**Krippendorf, C. & Schuller, F.**—Machinists and Jewelers' Tool Makers. 19 Greene Street, Newark, N. J. Rolls, Dies, Cutters, and Draw-plates of every Description made and repaired.

**Lelong, L. & Bro.**—Gold and Silver Refiners. Assayers and Sweep Smelters, Southwest corner of Halsey and Marshall Streets, Newark, N. J.

**Milne, Alex.**—Manufacturer of Stem-winding Watch Crowns. 19 Ward Street.

**Plumb & Marcus**—Manufacturers of Traveling and Marine Clocks, Electric Appliances. 289 Washington St., Newark, N. J.

**Regad, E. D.**—Lapidary. Specialty—Sardonyx, Black Onyx and Agates. 14 Oliver St., Newark.

### PROVIDENCE

**Arnold & Webster**—Manufacturers of Solid Gold Engraved Band Rings for the Jobbing Trade. 29 Point Street, Providence, R. I.

**Bradley, R. & Son**—Manufacturers of Solid Gold and Rolled Plate Jewelry. White Stone Goods a Specialty. 227 Eddy Street, Providence, R. I.

**Capron & Co.**—Manufacturers of Jewelry. Engraved Box Bracelets, Bangle Wire Bracelets, Original Lever Collar and Cuff Button. No. 407 Pine Street, Providence, R. I.

**Coombs & Tuttle**—Manufacturers of a large variety of Fine Bracelet and Eye-Glass Chain in Gold Plate and Silver, Spring Rings, Holders, Hooks, Snaps, etc. 35 Point St., Providence, R. I.

**Hamilton, William & Co.**—Manufacturers of Fine Rolled Plate Chains and Patent Band Bracelets. 116 Pine St., Providence, R. I.

**Hough, W. S., Jr., & Co.**—Manufacturers of the Hough, Jr., Rolled Plate Locketts, Charms and Pendants. For sale by all first-class Jobbers or Wholesale Jewelers in the United States and Canadas.

**Hutchison & Huestis**—Makers of Solid Gold Rings. Quality guaranteed. For the Jobbing Trade only. 185 Eddy Street, Providence, R. I.

**Irons, Chas. F.**—Manufacturer of Solid Gold Jewelry. Specialty. Emblems, Pins and Charms, Masonic, Odd Fellows, etc. 102 Friendship St.

**Pearce & Hoagland**—Manufacturers of Gold Pens, Holders, Pencils, Tooth Picks, etc. Also the Quill Reserve Tooth Pick. 29 Point Street, Providence, R. I.

**Pitts & Hicks**—Manufacturers of the Excelsior Button and Eclipse Lever Button, also a line of White Stone Gold Goods and a fine line of Lace Pins and Drops in Rolled Plate Goods, 120 Dorrance Street, Providence, R. I.

**Taylor, Geo. H. & Co.**—Watchmakers and Wholesale Dealers in Watches, Clocks, Watch and Clock Material, Tools, Spectacles, Eye Glasses, &c. Particular attention given to trade work. 136 Westminster Street (Room 1), Providence, R. I.

### PAWTUCKET.

**Draper, J. O. & Co.**—Manufacturers of Jewelers' Fig Soap, adapted for Washing Jewelry, Scratch Brushing and Drawing Wire. Pawtucket, R. I.

**Fuller, Geo. H. & Son**—Jewelers' Findings, Gold, Silver, Gold Plated and Fire Gilt. Pin Stems, Joints, Catches, Split Rings, Chain Hooks and Swivels, Ear Wires, Chain Bars, etc. 99 Exchange Street, Pawtucket, R. I.

### CINCINNATI.

**Hellebush, Clemens**—Manufacturer, Importer and Wholesale Dealer in everything required by the Jewelry Trade. 77 W. Fourth St., Cincinnati, O.

**Holland, John**—Manufacturer of Gold Pens, Pencils and Pencil Cases, Gold Toothpicks, etc. Nos. 19 and 21 W. 4th St., Cincinnati, Ohio.

**Lodwick & Nolting**—Wholesale Jewelers, S. W. cor. 4th & Walnut Streets, Cincinnati.

### BALTIMORE.

**Gruebel & Kesmodel**—Manufacturers of Fine Diamond Etruscan, Enameled, Plain and Rhine Stone Jewelry to order. Repairing a specialty. Orders by Mail solicited. 212 & 214 W. Baltimore St., Balto., Md.

### BOSTON.

**Boston Watch Case Co.**, makers of Watch Cases. Especial attention given to Repairing. 1, 3 & 5 Province Court, Boston, Mass.

**Boyce, E. J.**—Manufacturer of Solid Gold Jewelry. Rings a Specialty. 383 Washington St., Boston, Mass.

**Smith, Wm. A.**—Importer of Diamonds and Precious Stones. Diamonds mounted and unmounted and Diamond Mountings. 383 Washington St., Boston, Mass.

**Weber, H. & Co.**—Wholesale Jewelers, Importers and Jobbers of Fine Watch Materials, Jewelers' Findings, Tools, etc., Optical Goods and Silk Guards. Agents for Whitcomb, Standard and Stark's Lathes. 424 Washington St., Boston, Mass.

### BUFFALO.

**King & Eisele**—Manufacturers of Solid Gold Jewelry, and Agents for American and Foreign Watches; also Jobbers in Roll Plate Jewelry. Office and Salesrooms, 283 Main St. Factory, 2, 4, 6 and 8 Swan St.

**Oliver, W. W.**—Manufacturer of Hand and Power Rolling Mills for Jewelers and Silversmiths, 39 Clinton Street, Buffalo, N. Y.

### CLEVELAND.

**Chandler, J. M. & Co.**—Manufacturers of the Patent Embossed Bracelet and Jobbers in all kinds of Clocks, Watches, Jewelry, Tools, Materials, etc. 185 Superior St., Cleveland, O.

### LANCASTER.

**Bowman & Musser**—Jobbers in Watches, Clocks, Chains, Fine Tools and Materials. 20 East Chestnut Street, Lancaster, Pa.

### PITTSBURGH.

**Barrett, G. B. & Co.**—Importers and Wholesale Dealers in Watches, Diamonds, Jewelry, Clocks, Bronzes, Silver and Plated Ware, Watch Materials, &c., 238 & 240 Liberty St.

**Goddard, Hill & Co.**—Wholesale Dealers in American Watches, Jewelry, Silverware, Clocks, Materials, &c., 43 Fifth Avenue, Pittsburgh, Pa.

**Hodge, Slemmons & Co.**—Wholesale Dealers in American and Swiss Watches, Diamonds, Gold and Plated Jewelry, Clock Material, etc. No. 77 Fifth Ave., Pittsburg.

### NEW BEDFORD.

**Nye, W. F.**—Manufacturer of Watch, Clock and Chronometer Oils, New Bedford, Mass.

### CANADA.

**Ellis, P. W. & Co.**, No. 31 King street, East Toronto, Ontario, Manufacturing Jewelers, Watchmakers, importers and Jobbers of Watchmakers, and Jewelers' Tools, Materials, General Supplies and American Jewelry. Correspondence solicited with manufacturers of Novelties or specialties in American Tools and Jewelry.

GEO. W. DUBOIS.

F. N. NAUMAN.

## GEO. W. DUBOIS & CO.,

IMPORTERS OF

# Watches & Optical Goods.

ALL STYLES AND QUALITIES OF

SPECTACLES AND EYE-GLASSES.

## Longines' Watches and Movements,

The Watches in Gold, Silver and Nickel Cases of New and Handsome Patterns. The Movements fit 18 size Waltham Stem Winding Hunting Cases.

36 Maiden Lane, New York.

ORDERS BY MAIL RECEIVE PROMPT ATTENTION.

## BARNES' No. 4 LATHE,

For the Heavier Work of Jewelers.

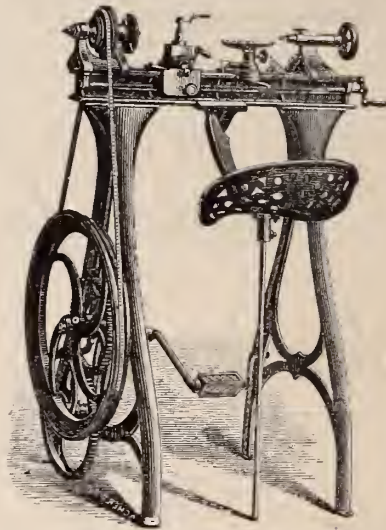

Barnes' Patent Foot and Steam Power Machinery. Complete outfits for Actual Workshop Business. Lathes for wood or metal. Circular Saws, Scroll Saws, Formers, Mortisers, Tenoners, etc., etc. Machines on trial if desired. Descriptive Catalogue and Price List Free.

W. F. & JOHN BARNES,  
2088 Main Street, ROCKFORD, ILL.



SOLID GOLD

AND

STONE INLAID

Cigar Cutter,

Pat'd Oct. 5, 1880.

J. WIENHOLD,

Manufacturer of FINE JEWELRY.  
DIAMOND MOUNTINGS A SPECIALTY,  
24 John St., N. Y. City,



# NEW YORK OPTICAL COMPANY,

OFFICE:

43 MAIDEN LANE, N. Y.

FACTORIES:

Cor. Jay & Plymouth Sts., Brooklyn.

MANUFACTURERS OF

## The Patent Eureka INTERCHANGEABLE

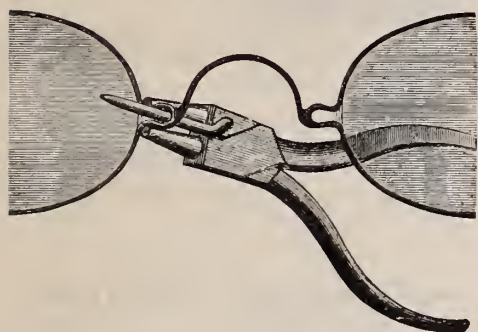

TO CLOSE LOOP OR PUT  
LENS IN FRAME.

## SPECTACLE

AND

## EYE-GLASS.

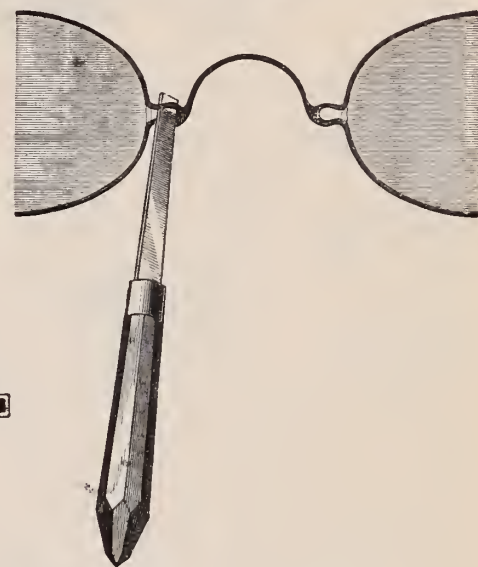

TO OPEN LOOP OR TAKE  
OUT LENSE.



IN GOLD, SILVER, GERMAN SILVER AND STEEL.

Completely INTERCHANGEABLE in all its parts.

# Beauty, Simplicity, Lightness and Strength!

*These Spectacles are absolutely interchangeable, and duplicate parts may be selected at hazard with a positive certainty of accurate adjustment.*

*The loops of the eye-frames can be enlarged or contracted at will, so that lenses of various sizes may be made to fit tightly in the same frame, thus securing an Interchange of Lenses.*

*The joints or end pieces are made of a slender solid piece of metal from one-quarter to one-half the usual size, and are so constructed that the Temples can be easily detached from one frame and freely adjusted to any other, thereby securing the Interchange of Temples.*

*Should the Temples become loose through wear, they may be easily tightened by the aid of a screw driver.*

## The Simplicity and Solidity of Construction, Lightness of Weight and Interchangeable Quality,

*render them exceedingly Desirable Goods for Dealers to handle, and certainly the most satisfactory to the general wearer, while the price cannot fail to attract the attention of Dealers.*

A Full and Complete Assortment of these Goods kept by the Jobbers.

# A NEW DEPARTURE.



## 14 KARAT GOLD CHAIN, SILVER LINED,

— MADE BY —

### A NEW PROCESS.

Guaranteed to wear as well as the best 14 karat Gold Chain made.  
Every Chain warranted to assay one-third ( $\frac{1}{3}$ ) its entire weight in gold.  
Each Chain stamped with registered trade mark:



*Showing the Relative Thickness*  
OF THE GOLD AND SILVER.



*Showing the Relative Thickness*  
OF THE GOLD AND SILVER.

Money refunded if test is unsatisfactory.

### KOSSUTH MARX & CO.,

Proprietors and Manufacturers,

39 Maiden Lane, New York.

In introducing our new Chain we aim to supply a want which we believe the Trade can place before the public in a legitimate manner without deception, and no detriment to the standard of the most scrupulous dealer.

We offer these goods strictly upon their merits, and give but a few reasons why they can take the place of the older styles of manufacture, viz.:

- 1st.—*In the make up there is no base metal, excepting such as is necessary in standard 14 karat.*
- 2d.—*It makes a larger and more showy appearance for its corresponding weight than the old standard.*
- 3d.—*The cost is materially reduced, bringing it within reach of a greater number who desire a good article.*
- 4th.—*It is a well known fact that the principal cause of wear in chain is the friction produced by its own weight, consequently, being light weight to the extent of a large percentage, their better wear is assured.*

By a strict adherence to quality we hope to create a popular demand for a meritorious article.

Send for selection package, as our travelers do not carry any in stock.

KOSSUTH MARX & Co.

ADOPTED AND IN USE BY  
**RANDEL, BAREMORE & BILLINGS,**  
 88 Nassau Street, N. Y.

THE TRADE SUPPLIED.  
 Descriptive Circulars Furnished  
 on Application to  
**George W. Washburn, Patentee,**  
 88 Nassau St.,  
 NEW YORK.

**SAFETY**  
**EAR FASTENING,**   
 Pat. May 10, '81—Oct. 11, '81.

**Jointed**  
**EAR WIRE**  
 AND  
**BAR BETWEEN CRAMPS**  
**OF SETTINGS.**   
 Patented March 1, 1881.

**TELESCOPIC**  
**SAFETY PIN CATCH,**   
 Pat. Sep. 20, '81—Jan. 10, '82.

**IMPORTANT TO THE TRADE!**

ESTABLISHED 1869.

**CHARLES REISS,**  
 Watch and Chronometer Maker.

Repairing for the Trade only. Send for Price List. Receive Jobs all over the U. S. by Mail or Express. Replace Broken Parts of Watches at Low Prices. Fine Repairing Establishment, and none but Experts employed.

**31 and 33 South Pearl Street,**  
**ALBANY, N. Y.**

**J. R. WOOD & SON,**  
 MANUFACTURERS OF

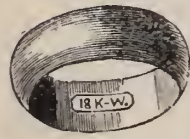

**Solid Gold Rings**  
 AND

**Diamond, Stone and Children's Rings,**  
**14 John Street, N. Y.**

No Goods Stamped Different from Quality.

**REUBEN HAINES,**  
**ANALYTICAL CHEMIST,**

**NO. 738 SANSOM ST.,**  
**PHILADELPHIA.**

Laboratory for Assay and Analysis of  
**GOLD AND SILVER ORES, LEAD, COPPER,**  
**ZINC, IRON, STEEL, COAL,**  
**WATER ANALYSIS.**



**BURGESS'**  
 Patent Portable Mechanical  
**BLOW-PIPE,**

Supersedes the Forge, Bellows and Mouth Blow-pipe, by saving time, labor, and breath, giving the gentlest flame or hottest blast without exertion.

PRICE, - - \$10.00.  
**J. ELLIOTT SHAW,**  
 154 South 4th Street, Philadelphia.

**John F. Stratton & Co.,**  
 No. 49 Maiden Lane, NEW YORK.  
 Importers and Wholesale Dealers in

**Violin Strings**  
 And all kinds of Musical Merchandise.

ALSO  
**Music Boxes, Musical Novelties, Ladies' Musical Work Boxes, Glove Boxes, Etc.**

SEND FOR DESCRIPTIVE CATALOGUE.

**P. JANDORF & BRO.,**  
**WATCHES & JEWELRY**

196 BROADWAY,

Bet. John & Fulton Sts., NEW YORK.

We Publish No Price Lists.

**Watchmakers' Slide Rests**  
 A SPECIALTY.

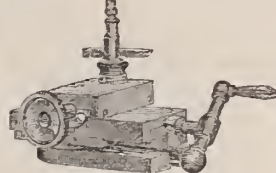

TWO STYLES,  
 PRICE,  
**\$10.00 & \$16.00.**

Warranted as good as the best. Sent C. O. D. on approval. Write for Illustrated Circular to the Manufacturer

**R. H. FRAZEE,**  
**TOLEDO, IOWA.**

**Washburn & Moen M'fg. Co.,**  
**WORCESTER, MASS.**

Manufacturers of Fine Watch Mainsprings for American, Swiss and English Watches, which, for Toughness, Elasticity and Finish, are Unequaled.

N. Y. Warehouse: **16 Cliff Street.** Chicago Warehouse: **107 to 109 Lake St.**

ESTABLISHED 1873.

**CHAS. P. HEROLD**  
 MANUFACTURER JEWELER  
**DIAMONDS**

916 CHESTNUT STREET UP STAIRS  
**PHILADELPHIA**

**H. WASELL,**  
**RUBBER STAMPS,**  
**BRASS STAMPS,**  
 Brushes, Inks, &c.  
 Stencil Plates,  
 Burning Brands,  
**SEALS & PRESSES,**  
 No. 7 North William St.  
 First house South of East River Bridge, N. Y.

**FINE STEEL STAMPS A SPECIALTY.**

**C. KNAPP,**  
 Manufacturer of  
**Superior Band**  
 and Children's  
**Stone & Fancy**  
**RINGS**



And Enameled Goods,  
**41 Maiden Lane,**  
**NEW YORK.**

**WILLIAM ERNST MOUTOUX,**  
 Leading Artist in Hair of the World

AND MANUFACTURER OF  
**GOLD AND HAIR JEWELRY,**  
 OFFICE AND FACTORY,  
**81 Nassau St., Rooms 1 & 2,**  
 BRANCH,

**18 Lawrence St. West of 126th,**  
**Mear Ninth Ave., NEW YORK.**

My New Catalogue of 1700 New Designs of Monuments with Weeping Willows, Wreaths, Bouquets, Crosses, Churches, Sceneries, Portraits, Pet Animals, Engravings of the Most Difficult Description, Etc. Wholesale prices for Hair Chain Braids in Assorted Colors, by the gross or dozen at half of book prices. Devices made at half of book prices if necessary. 15-5 per cent. cash discount on the prices of the old book.

**GEORGE UIBEL,**

MANUFACTURER OF  
**Sea Bean & Alligator Teeth**

—\*— JEWELRY —\*—

**142 Fulton St., N. Y.**

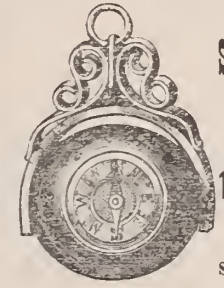

Send for Catalogue and Price List.

**DANGERFIELD'S**  
**IGNITING MATCH CASE**

The Celebrated SELF-IGNITING MATCH CASES, (with or without Cigar Clipping Attachment), pronounced the ACME of PERFECTION. No Gentleman or Lady can afford to be without one, it saves your clothes, walls and furniture. Many dangers and inconveniences are overcome. **Samples by Mail,** post paid to any part of the world, on receipt of price. **Solid NICKEL SILVER, 50c. XX TIN, 25c.** Prices, Discounts and Terms on application. Address **FRANCIS S. DANGERFIELD, Proprietor and Sole Manufacturer, Auburn, N. Y., U. S. A.**

PAT 1879, '80, & '81

MATCH CASE OPEN

# Spencer Optical Manuf'g Co.

ARE NOW MAKING MANY

**NEW**

AND

**Desirable Styles**

FOR THE

**Early Spring Trade.**



**Indestructible Celluloid Spectacles,**  
Our Gold Goods are Unsurpassed  
for Beauty, Durability  
and Finish.

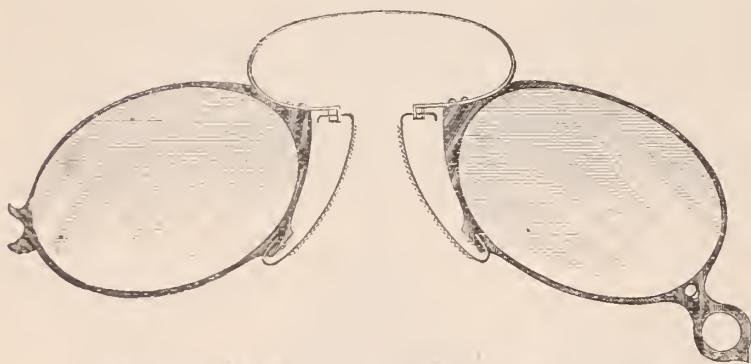

## CELLULOID SPECTACLES.

The very latest improvement, made in Shell and Amber Color; it has substantial advantages over all others, being strong, light and not subject to rust.

THE

## CELLULOID EYE-GLASS

has made its own reputation and is universally popular wherever introduced.

### BEWARE OF IMITATIONS.

We make a **SPECIALTY** in **SPECIAL GOODS** for the **FINE RETAIL TRADE**, which gives customers handling our goods **IMMENSE ADVANTAGE** over all others.

### QUALITY OF GOLD GUARANTEED.

We are importing large Invoices of Opera, Field and Marine Glasses in Staple and Novel Designs.

Catalogue sent on receipt of Business Card.

**Spencer Optical Manufacturing Co.,**  
13 MAIDEN LANE, NEW YORK.

Established 1853.

# L. H. KELLER & CO.

Successors to G. A. HUGUENIN,

IMPORTERS OF

WATCHMAKERS' and JEWELERS'

## TOOLS AND MATERIALS.

GENERAL AGENTS FOR

The Philadelphia Watch Company,

— AND —

American Watch Tool Co.,

MANUFACTURERS OF

## THE WHITCOMB LATHE.

SOLE AGENTS IN THE UNITED STATES FOR THE SALE OF

**LUTZ'S**

## CELEBRATED ROLL HARDENED HAIR SPRINGS, MOEBIUS OIL.

For Chronometers, Watches, Clocks, Telegraph Instruments and all other delicate machinery. Made from Pure Refined Neatsfoot Oil, and Warranted to Excel anything in the market as a Lubricator. **SAMPLES GRATIS.**

### OUR OWN GRADUATED

AND JURGENSEN RECOILING MAINSPRINGS, pronounced by all experts Superior to all. Sold in Separate Strengths or Force.

Extra Fine Pinions cut from Solid Steel Wire. Gauged Hole Jewels of First-class Workmanship. A Full Line of Materials, for the PATEK, PHILIPPE & CO. GENEVA WATCHES, and all other Celebrated Makers.

## THE BOLEY LATHES AND TOOLS,

Celebrated for their Practical, Substantial and Workmanlike Construction, Superior Design and Finish.

*Our aim is to furnish nothing but First-class Serviceable Goods, especially manufactured for the Consumer, and not solely for the Market, like the cheap trash advertised in highly illustrated catalogues with which the country is flooded.*

**TREATISE ON MODERN HOROLOGY IN THEORY AND PRACTICE.** By M. CLAUDIUS SAUNIER, Ex-Director of the School of Horology at Macon, France; Knight of the Legion of Honor, etc.; Hon. Sec. to the Paris Society of Horologists. Translated from the French by JULIEN TRIPPLIN, Besançon Watch Manufacturer, and EDWARD RIGG, M. A., Assayer in the Royal Mint, London.

This Work comprises 832 large octavo pages, with 78 wood cuts and 21 colored double-page copper-plate engravings. Bound in half calf, with an appropriate and handsome ornament in gold on front cover.

**Price, \$15.00.**

**THE WATCHMAKER'S HAND BOOK.** By the same author and translators. Intended as a companion to the Treatise. Bound in cloth.

**PRICE, \$4.00.**

**64 Nassau Street,**

NEAR MAIDEN LANE,

**NEW YORK.**

L. H. KELLER,  
EDWARD HUNZIKER, }  
P. J. BOESSE.

We do not publish Price Lists.

**SPECIAL NOTICES.****Notices under this Heading, not to exceed Six Lines, \$1.00 each insertion.**

Advertisers having letters addressed in care of this office, must inclose postage for answers forwarded.

**FOR SALE CHEAP**—A Herring safe, 5x8 by 4x4, at John A. Riley & Co.'s, 9 Bond St.

**WANTED**—A situation by a thoroughly competent watchmaker and engraver. Address Box 318, Syracuse, N. Y.

**FOR SALE**—Half interest in a well-established jewelry and tool and material jobbing business. Address S. C. care Circular.

**WANTED** to purchase, a good second-hand engraving machine. Address, giving price, name of maker, &c., to Engraver, care T. A. Beguella, 71 Nassau St., New York.

**WANTED**—A large second-hand Verge Lathe; length of bed, 9 to 12 inches; also watchmakers' cutting engine. Must be cheap. Address with price and description, P. O. Box 129, Batavia, Ohio.

**A GOOD WATCHMAKER**, jeweler and engraver, capable of doing first-class work in these branches, wishes a situation immediately. Address Geo. W. Wilson, Commercial Hotel, Columbus, Ohio.

**WANTED**—An experienced clock maker, one accustomed to new work preferred. None but good workmen need apply. Address or call D. Rousseau's Electrical Works, 135th street and 4th avenue, N. Y.

**WANTED**—By a first-class watchmaker and engraver a permanent situation with a good house. Have a complete set of the latest improved tools. Good reference furnished. Address A. B. C., care Jewelers' Circular.

**MOSELEY & CO.**, Elgin, Ill., manufacturers of the "Moseley" Lathe, with full line of fixtures and attachments. Designed especially for the watchmaker and repairer. Combining accuracy, durability, convenience and style.

**A FIRST-CLASS watchmaker** is desirous of securing an engagement by the 1st of May, town or country, 18 years' experience in London, Paris and New York. Thoroughly reliable in every way. Salary moderate. Address A. Long, 344 King street, Charleston, S. C.

**FOR SALE**—Jewelry and stationery store in live town of 5,000 inhabitants in western New York. Stock and fixtures invoice about \$5,000. Good location, trade and run of work; sales increasing and good reasons for selling. Address H. J. F., care Jewelers' Circular.

**WANTED**—A good paying established jewelry business in town or city of 5,000 to 15,000 inhabitants. Stock and fixtures in good shape. Must be in a location pleasant to reside in. Wish to invest from \$5,000 to \$6,000. Address J. Mainspring, care Jewelers' Circular.

**FOR SALE**—The leading jewelry store in Carlisle, Pa., a thriving town of 7,000 inhabitants. Store established over 40 years. Doing a good business and room for a large increase. Will sell with or without fixtures. Cash required about \$5,000. Address R. H. Conlyn, Carlisle, Pa.

**FOR SALE**—A well-paying jewelry business in a Texas town. Population 1,500. Three railroads. Good run of work and low rent. Nearest competition 25 miles. Stock and fixtures will invoice about \$3,000, but can be reduced. Address G. F. F., care Jewelers' Circular.

**WANTED**—A watchmaker competent to do best work in general repairing of watches. A fine light and well ventilated place for working; permanent situation to a suitable person, german preferred. Address, stating wages, reference, &c., Geo. F. Applegat, Watchmaker, Trenton, N. J.

**GEORGE E. WILKINS**, manufacturer and importer of cutters for watchmakers' use, stem-winding cutters of all the different forms, rounding up cutters of the finest quality, also ratchet cutters. A large stock of second hand and new marine chronometers. No. 21 South Salina street, Syracuse, N. Y.

**A YOUNG MAN** with seven years' experience in the jewelry business, acquainted with the trade on the road, and the New York City jobbing trade, desires a position with a first-class New York house, or would represent Providence manufacturer in New York City or on the road. L. C., Jewelers' Circular.

**WANTED**—Partner with three to four thousand dollars in an established wholesale and retail jewelry business in a good manufacturing town of 18,000 population in northeastern Ohio. A practical watchmaker preferred. If requested other arrangements can be made. Address Enterprise, care Jewelers' Circular.

**FOR SALE**—A well-established, first-class jewelry business in a leading mining town in Nevada. County seat. A good chance for a watchmaker. A well-assorted stock of fine watches, jewelry, silverware and clocks, optical goods, also very fine fixtures and large safe. For all particulars address P. Steler, Eureka, Nevada.

**I HAVE \$1,000 to \$20,000 to invest** in a good business, some branch of the watch, jewelry, silverware, clock or optical business preferred, as I am a practical watchmaker and have a good retail trade. No notice taken of communication unless full name and particulars are given. Address Post Office Box 2110, Philadelphia, Pa.

**FOR SALE CHEAP**—The entire stock and fixtures of a neat and well-appointed jewelry store situated in one of Pennsylvania's most flourishing towns. This is the best stand in the place, and to the right man will be sold on liberal inducements. Satisfactory reasons given for selling. For particulars call on or address S. B. Rinehart, Waynesboro, Pa.

**FOR SALE**—A well-established jewelry business in a town of 1200 inhabitants. Splendid schools, 1 university and 2 seminaries, all in flourishing conditions. Fine churches, &c. No opposition; good run of work; stock and fixtures invoice about \$3,000; best of reasons given for selling. For terms, &c. address P. O. Box 707, Granville, Licking Co., Ohio.

**FOR SALE** Rare opportunity. A first-class jewelry store in one of the best towns in Illinois of 7,000 inhabitants. County seat, three railroads, college and large manufactories. Doing a good business and will bear investigation. Good clean stock. Reason for selling poor health. If you mean business, address for particulars, A. J. Green, Monmouth, N. J.

**SITUATION WANTED**—By a Norwegian watchmaker to go to the Northwest, Minneapolis and St. Paul preferred. Has had 6 years' experience at the bench as watch repairer, and is familiar with repairing complicated watches and clocks. References from present employers, an old and reliable New York firm, where I have had charge of watch work for last two years. Address, with particulars, "Norwegian," care Jewelers' Circular.

**FOR SALE**—An old-established jewelry business which the present owner started 30 years ago. Stock consists of diamonds, watches, clocks, jewelry, silver and plated ware, etc. to the amount of about \$15,000, all well selected and in good order. Store situated in a city of 60,000 inhabitants. Will sell on easy terms to a responsible purchaser. The strictest investigation is invited. Address A. B. C., care Jewelers' Circular.

**TO THE TRADE**—I make a specialty of supplying the Trade with stones for jobbing purposes. Parties having jewelry out of which the stones have been lost, sending their orders by mail or express, will have them promptly attended to. A large stock of cameos, pearls, turquoise, garnets, amethysts, doublets, foil backs, white and colored imitation stones on hand. All kinds of setting done for the Trade. W. Archibald, 73 Nassau street, New York.

**FOR SALE**—One of the cleanest stocks and best locations in the U. S. for the size of the city. Stock and fixtures invoice about eight thousand. Has paid over seventy-five per cent. net profit each year for the last three years. Store is brick, iron columns, plate glass front and one of the neatest buildings and store fixtures in the state. Will sell store or rent it. Counters are low and cases high and all plate glass. Will sell tools and materials or without. Population thirty-five hundred. Two R. R., five churches, public schools, state agricultural college in flourishing condition, opera house, city fire department and water works, good hotels. Object of selling, simply this and nothing more: We have all the money we need and made every cent except twenty dollars, our original capital, right in this city and in this business in the last five years, and wish to retire from business. City in an agricultural part of the state and growing rapidly. No we do not wish to trade in for cats or dogs or real estate, but those having cash or bankable security and wishing to invest in the jewelry business will do well to investigate. None others need apply. Address E. W. Reed, Fort Collins, Colorado. Reference, Aikin, Lambert & Co., 23 Maiden Lane, N. Y.

**BUYERS' DIRECTORY.****NEW YORK.****Assayers and Sweep Smelters.**

**Wundoehl, H.**—Gold and Silver Refiner, Assayer and Sweep Smelter. 21 John Street, N. Y.

**Badges and Medals.**

**Stockwell & Newman**—19 John Street. Manufacturers of Badges, Medals and Presentation Pieces in Gold and Silver. Also Jewelry and Mounters of Diamonds. Designs supplied.

**Band Rings.**

**Knapp, Charles**, 41 Maiden Lane, N. Y. Specialty: Superior Band Rings, also Ring Shanks & Heads for Seal and Diamond Rings.

**Black Onyx Jewelry.**

**Cox & Sedgwick**—Manufacturers of Black Onyx Jewelry, No. 26 John St. New York.

**Lawson, Samuel**—No. 18 John Street. Manufacturer of Black Onyx Jewelry. Coral repaired for the trade. Goods sent on approval to responsible dealers.

**Woglom & Miller**—Manufacturers of (exclusively) Black Onyx Jewelry, 32 & 34 John St., N. Y.

**Blue Enameled Lockets.**

**Bissinger, Philip & Co.**—Importers of Diamonds, Pearls and Precious Stones. Agent for the Bohemian Garnet Goods. Blue Enameled Lockets, 22 John St., N. Y.

**Emrich, I.**—Importer of Blue Enameled Lockets, Ear Drops and all kinds of Enameled Jewelry; also Enamel for Manufacturing purposes. 66 Nassau St., N. Y.

**Hess & Schliesser**—Importers of Diamonds, Fine Jewelry and Novelties in French Goods. Specialties: Gold and Blue Enameled Lockets, Charms and Crosses. 25 Maiden Lane.

**Bohemian Garnet Jewelry.**

**Bissinger, Philip & Co.**—Importers of Diamonds, Pearls and Precious Stones. Sole Agent for the Bohemian Garnet Jewelry. Blue Enameled Lockets. 22 John St.

**Emrich, I.**—Importer of Half Pearls and Bohemian Garnet Jewelry. Designs made to order in our European Factory at moderate prices. 66 Nassau St., N. Y.

**Clock Companies.**

**Ansonia Clock Co.**—Manufacturers of every description of Clocks. 11 to 21 Cliff street, New York.

**Kroeber, F.**—Manufacturer and Dealer in American and French Clocks, No. 14 Cortlandt Street.

**New Haven Clock Co.**—16 and 18 Park Place, N. Y.

**Seth Thomas Clock Co.**—20 Murray Street, N. Y.

**Waterbury Clock Co.**—M. Bailey, Treasurer, Manufs and Jobbers, No. 4 Cortland St., N. Y., and No. 197 State Street, Chicago.

**Welch, E. N., Manufacturing Co.**—Manufacturers of American Clocks. No. 6 Warren St.

**Wm. L. Gilbert Clock Co.**—No. 6 Murray Street, Manufacturers of Clocks. Factories, Winsted, Conn.

**Cameo Cutters, Etc.**

**Feiter, Theodore**—Cameo and Intaglio Engraver. Patentee of the Cameo-Intaglio. No. 2 Bond Street, near Broadway, Room 4 New York.

**Charms & Gold Watch Keys.**

**Rupp & Held**,—Manufacturing Jewelers, Charms and Gold Watch Keys, with French and English Rachets, a specialty. 15 John St., N. Y.

**Crucibles.**

**Berge, J. & H.**—Established 1850 Importers of Sand Crucibles, Covers, Chemical Porcelain, Glassware, and Jewelers' and Assayers' Supplies 95 John Street, N. Y.

**Cutlery.**

**Harrison Bros. & Howson**,—Manufacturers of Fine Ivory and Pearl Table and Pocket Cutlery, Carvers in Cases; Nutpicks, Nutcracks and goods suitable for the jewelry trade. 126 Chambers Street. W. C. Burkinshaw, Sole Agent.

**Diamond Brokers.**

**Anderson, Otis**—Diamond Merchant and Broker, always ready to pay cash for bargains in Diamonds and Precious Stones, 4 & 6 John Street, N. Y.

**Bernhardt, Richard**—Diamond Broker and Importer, 65 Nassau Street (Room 6), N. Y. Paris, 20, rue des Petites-écuries.

**Friend S. & Son**—Brokers and dealers in Diamonds 33 John Street, cor. Nassau St. New York.

**Herbert, R. J.**—Diamond Broker and Dealer, 26 Maiden Lane.

**Diamond Importers.**

**Bernhard, A. & Co.**—Importers of Diamonds and Manufacturers of First-class Diamond Jewelry, Diamond Settings for Manufacturing Jewelers. Catalogue of Designs for the Trade free of charge. No. 2 Maiden Lane, New York.

**Bissinger, Philip & Co.**—Importers of Diamonds, Pearls and Precious Stones. Agent for the Bohemian Garnet Goods. Blue Enameled Lockets, No. 22 John St., N. Y.

**Bruhl, D. & M.**—Established in 1848. 14 Maiden Lane, N. Y.; 111 Broad Street, Providence, R. I.; 14 Rue Bleue, Paris.

**Brunswick, S. & Co.**—Importers of Diamonds, 17 Maiden Lane, New York. Paris, Rue Lafayette. Amsterdam, Damstraat.

**Citroen, L. B. & Co.**—Diamonds, 21 John St., N. Y. Cutting Works, 57 & 61 Rapenburgerstraat, Amsterdam. House in Paris, 44 Rue Laffite.

**Faulkenau, Oppenheimer & Co.**—Manufacturers. Diamonds and Diamond Jewelry. 40 Maiden Lane, N. Y.

**Fera, Henry**—Importer of Diamonds, and Manufacturer of Fine Diamond Jewelry. 4 & 6 John Street, New York. Amsterdam, Holland, 23 Loojersgracht.

**Fox, M. & Co.**—Importers of Diamonds, Rubies, Sapphires and Fancy Gems. No. 1 Maiden Lane, New York

**Hedges, Wm. S. & Co.**—Importers of Diamonds No. 170 Broadway, corner Maiden Lane.

**Henle Brothers**—Importers of and Wholesale Dealers in Diamonds only. No. 16 Maiden Lane, N. Y. Paris, 20 Rue Lafitte.

**Kuhn, Doerflinger, & Co.**—Manufacturing Jewelers and Importers of Diamonds, 18 John street New York

**Leberthon, L. M.**—Importer of Diamonds and Manufacturer of Fine Jewelry. 14 John Street, N. Y.

**Mulford & Bonnet**—No. 21 Maiden Lane, New York.

**Neresheimer, E. Aug. & Co.**—Importer of Diamonds. No. 21 Maiden Lane, New York.

**Randel, Baremore & Billings**—Importers of Diamonds, corner Maiden Lane and Nassau St.

**Saril, S.**—Importer of Diamonds, 182 Broadway, N. Y. Branch of Vve. H. A. Marchand & Frères, 47 Rue Le Pelletier, Paris.

**Saunders & Ives.**—Importers of Diamonds and other Precious Stones. No. 26 Maiden Lane.

**Smith, Alfred H. & Co.**—Importers of Diamonds, No. 182 Broadway.

**Tannenbaum, L. & Co.**—Importers of Diamonds and Precious Stones. Steam Lapidary Works. Oriental Stones Cut and Polished a specialty. 65 Nassau St., N. Y.

**Taylor & Brother.**—Importers of Diamonds and Diamond Jewelry. 676 Broadway.

**Wickham, D. H. & Co.**—Importer of Diamonds. No. 31 Holborn Viaduct, London, 24 Maiden Lane, New York.

**Wolff, G. A.**—Importer of Diamonds, Rubies, Sapphires, Pearls, and other Precious Stones, 65 Maiden Lane, New York. 12 Rue de Chateaudun, Paris.

#### Diamond Jewelry.

**Baldwin, Sexton & Peterson**—Importers of Diamonds and Manufacturers of Diamond Jewelry, 692 and 694 Broadway, N. Y.

**Bornemann, Louis.**—Importer of Diamonds and Manufacturer of Rich Diamond Jewelry, 19 John Street, New York.

**Chalumeau, D.**—Diamond Jeweler and Manufacturer of Mountings. Novelties and Artistic Jewelry. No. 3 Maiden Lane, New York.

**Goldsmith, Ingomar & Co.**—Manufacturers of Diamond Mountings and Diamond Jewelry, 61 Nassau Street, New York.

**Goldsmith & Co.**—Manufacturers of Fine Diamond Mountings and Diamond Jewelry. Lace Pins, Ear Rings and Rings a specialty. 49 Maiden Lane, N. Y.

**Hartje, G. & F.**—Manufacturers of Diamond and Fine Jewelry, 39 Union Square, N. Y.

**Haug, John**—Manufacturer of Fine Diamond Mountings, etc. No. 130 Fulton St., N. Y.

**H. lier & Bardel.**—Manufacturers of Diamond and Pearl Jewelry, and Dealers in Diamonds, Pearls, &c. 13 John Street.

**Jeanne Brothers.**—Manufacturers of Diamond Mountings & Rich Jewelry. 1 Maiden Lane.

**Lacroix & Verpillier.**—Manufacturers of Fine Gold Jewelry. Diamonds a specialty. 173 Broadway, N. Y.

**Luthy, A. & Co.**—Manufacturers of Fine Diamond Mountings, Lace Pins, Ear Rings, Rings, Knife Edge Bracelets, Hair Ornaments, etc., a Specialty. 35 Ann Street, corner Nassau Street, N. Y.

**Mitchell, Noah**—Manufacturer of Diamond Jewelry and Diamond Mountings. 52 Maiden Lane, New York.

**Nissen, Ludwig & Co.**—Dealers in Diamonds and Diamond Jewelry. No. 51 Nassau Street, New York, near Maiden Lane.

**Rosswog, C. & Son**—Manufacturers of Rich Diamond Goods. Nos. 5 and 7 Maiden Lane, N. Y.

**Scheer, William**—Diamond Jeweler and Manufacturer of Mountings, Novelties in Artistic Jewelry, 859 Broadway, near 17th St., N. Y.

**Stern, Louis**—Manufacturing Jeweler. Diamond Mountings a Specialty. 8 & 10 John St., N. Y.

**Voelker, C. T.**—Manufacturer of 18-k. Diamond Mountings, Diamond Jewelry and Roller Chain Bracelets. 189 Broadway, New York.

**Waterman & Lehmann.**—Manufacturing Jewelers and Dealers in Diamonds. Diamond Work, and Fine fancy Rings a specialty, any piece of single work made to order. 37 Maiden Lane, N. Y.

#### Diamond and Pearl Setter, & C.

**Danziger, H.**—Diamond and Pearl Setter, 116 Nassau Street, (Second Floor,) Room 6, N. Y.

#### Diamond Cutters.

**Levy, Herman.**—Importer, Cutter and Polisher of Diamonds. 105 Fulton Street, New York.

**Mendes, D. De S.**—Diamond Cutter and Polisher, 113 Nassau St., N. Y. Re-cutting, Repairing and Matching a Specialty.

#### Dials, & C.

**Farnsworth, C. E. & Co.**—Successors to Jno. T. Gold, Manufacturers and Jobbers in Fine Watch Dials. 81 Nassau St., N. Y.

**New York Dial Co.**—Manufacturers of Fine Watch Dials. Henry Abbott, Agent, No. 4 Maiden Lane, N. Y.

#### Enameled Clock Dials and Figures.

**Caeser Bros.**—Manufacturers of Enameled Clock Dials, also letters and numbers for signs. 230 and 232 East 25th Street, New York.

#### Enamelers, Etc.

**Nutt, J. D.**—Enameler on Gold, Silver, and Copper. Linen finished Buttons and Studs. Enameling in colors. 32 and 34 John Street, New York.

**Orr, J. C.**—Enameler on Fine Jewelry. Enameled in Colors. Linen Finished Buttons and Studs. Band Bracelets. No. 75 Nassau Street, N. Y.

**Orr, William N.**—Enameler on Fine Jewelry. Masonic Jewels and Badges a specialty. Linen Finished Work. 79 Nassau Street, Room 18, New York.

#### Engravers—Stone Seal, Etc.

**Fackner, Edward**—Carver, Engraver and Chaser on Jewelry and Pencil Cases, lettering, &c., 19 John Street.

**Holland & Gosling**—Stone Seal Engravers. Precious Stones inlaid and encrusted with Diamonds. No. 176 Broadway, New York, (fifth floor per elevator). Cameos cut and repaired.

**Knapp, Chas.** Engraver, Die Sinker & Stamper for Jewelry purposes. Ring Shanks & superior Band rings, 41 Maiden Lane, N. Y.

**Park, Wm.**—The Stone Seal Engraver. Arms, Crests, Monograms, etc., engraved on precious stones, 26 John Street, New York.

**Weston, James F.**—Stone Seal Engraver and in-cruster of Precious Stones. Coats of Arms, Masonic, Odd Fellows, and other devices engraved. 32 John Street.

#### Fancy Goods, Clocks, Bronzes, Etc.

**Hinrichs, C. F. A.**—Importer of Fancy Goods, Glassware, China, Clocks, Bronzes, etc. 31 Park Place.

**Le Boutillier & Co.**—Importers of Fancy Goods, Clocks, Bronzes, &c., 3 Union Square.

**Straus, L. & Sons**—Importers of Potteries, Faïences, Bisque Figures and Rich Fancy Goods especially adapted for the Jewelry Trade. 40, 42 and 44 Warren Street, New York.

**Taylor & Bro.**—Importers of French Clocks, Bronzes, etc. 676 Broadway, N. Y.

**Young, J. M. & Co.**—Importers of Fine Parian, Lava, and Bisque Statuary, Bohemian, German and English Fancy Goods, 37 & 39 Murray St., New York.

#### Gold and Silver Cane Heads.

**Cuppia, L. A.**—Importer of Filigree Jewelry and Manufacturer of Silver and Gold Cane Heads and Novelties in Silver and Gold Jewelry. 19 Union Square, N. Y.

**Simons, Bro. & Co.**—Manufacturers of Gold Headed Canes. 611 and 613 Sansom street, Philadelphia.

**Smith, Rest Fenner & Co.**—No. 701 Broadway, Makers of Fine Gold and Silver Headed Canes.

#### Gold and Silver Plating, Etc.

**Bantle, A.**—Gold, Silver and Electro-Plating, 130 Fulton and 89 Nassau Streets, cor. Fulton Street, (Room 36,) N. Y. Watch Case Polishing.

**Jeandheur, F. & Son.**—Gold and Silver Electro Platers & Fire Gilders, coloring Etruscan and Gold Jewelry a specialty. 125 Fulton St.

**Kless & Magrath**—Gold and Silver Electro-Platers. Coloring Etruscan and Gold Jewelry a Specialty. 89 Nassau Street, New York.

#### Gold Chains, Etc.

**Beck, J. & Son,** Manufacturers of Fine Gold Chains and Chain Bracelets, 10 Liberty Place, near Maiden Lane, N. Y.

**Carter, Sloan & Co.**—Manufacturers of Fine Gold Chain, 15 Maiden Lane, New York.

**Edge, W. C. & Co.**—Manufacturers of the Celebrated Woven Fabric Gold Chain, No. 15 John Street.

**Kaufmann Bros.**—Manufacturers of Gold Chains, and Chain Bracelets, 26 John Street; Factory, 331 and 333 Bowery, N. Y.

**Kohn, Alois & Co.**—Manufacturers of Gold Chains, 9 Maiden Lane, N. Y.

**Nordt, Charles.**—Successor to Nordt & Schlag, manufacturer of Gold Chains and Chain Bracelets. Jobbing and Refilling Old Chains promptly attended to. No. 17 Maiden Lane, N. Y.

**Saxton, Smith & Co.**—Manufacturers of Fine Gold Chain, No. 14 John Street, N. Y.

**Schlag, Chas.**—Late Nordt & Schlag, Manufacturer of Gold Chains, Chain Bracelets, and Fine Jewelry, 177 Broadway, N. Y. Repairing a Specialty.

**Smith, W. & Co.**—Manufacturers of Gold and Silver Chains, Jewelry, etc. No. 25 Maiden Lane, N. Y.

#### Gold Pens, Etc.

**Aikin, Lambert & Co.**—Manufacturers of Choice Gold Pens, Cases, Holders, Toothpicks, etc., 23 Maiden Lane, N. Y.

**Fairchild, Leroy W.**—Manufacturer of Gold Pens, Pencil Cases, Tooth Picks and Novelties in Charms. No. 18 John St., N. Y.

**Gerow, Joseph U.**—Manufacturer of Pencil and Pen Cases for the Jobbing Trade only. No. 44 State Street, (near South Ferry,) Brooklyn, N. Y.

**Hicks, W. S.**—Established 1848. Manufacturer of Fine Gold Pens, Pencil Cases, Tooth Picks, and Charm Novelties of every description. No. 20 Maiden Lane.

**Johnson, E. S. & Co.**—Manufacturers of Gold Pens, Pen Holders and Pencils. Cor. Maiden Lane and Nassau Street, New York.

**Ray Manufacturing Co.**—Gold Pens Manufactured and Stamped for the Trade. Also Pencil and Pen Cases, Tooth-picks, etc. Office, Sales-rooms and Factories, 94 and 96 Nassau street, 129, 131 and 133 Fulton street.

**Smith, H. M. & Co.**—Manufacturers of Gold Pens and Holders, Tooth Picks, Pencils, etc. Sole Manufacturers of Sprague's Patent Gold Fountain Pen. Importers of Nickel and Silver Watches. 173 Broadway, New York.

#### Gold Rings.

**Barnet Bros.**—Manufacturers of Stone and Seal Rings, 15 John Street, New York. Factory, Newark, N. J.

**Bowden, J. B. & Co.**—Manufacturing Jeweler.—Solid Gold Rings a specialty, 1 Maiden Lane.

**Dattelbaum & Friedman**—Manufacturers of Fine Cameo and Seal Rings, all kinds of Fancy Rings and Diamond Mountings. 10 Maiden Lane.

**Cable, Geo. W.**—Manufacturing Jeweler. Plain and Band Rings a Specialty. No. 104 Fulton Street, N. Y.

**Ely, W. H.**—Manufacturer of Solid Gold Rings of every description. No. 58 Nassau Street.

**Henrich, R.**—No. 35 Maiden Lane, Manufacturer of Gold Rings; also Patentee and Manufacturer of the Celebrated Self-Sizing Ring.

**Hutchison & Huestis**—Makers of Solid Gold Rings. Quality guaranteed. For the Jobbing Trade only. 196 Broadway, N. Y.

**Kroll, H.**—Manufacturing Jeweler. 78 Nassau Street, New York. Specialty: Solid Gold Stone Rings. All kinds of Fine Jewelry made to order, also Repairing for the Trade.

**Ostby & Barton**—Manufacturers of Plain and Engraved Solid Gold Band Rings. Office, 176 Broadway, N. Y. Factory, 80 Clifford Street, Providence, R. I.

**Peckham, Wm. H.**—Manufacturers of Solid Gold Seamless Rings, and Fancy Embossed Rings, Patent Spectacles, Jewelry, etc. No. 4 Liberty Place N. Y.

**Radler, K.**—Manufacturing Jeweler. Gold Rings and Lockets a specialty. No. 39 Maiden Lane, New York.

**Sauter, L.**—No. 1 Maiden Lane, New York, Manufacturer of Stone Rings of every description, as Diamond, Cameo, Onyx Turquoise, etc., Scarf Pins, Scarf Rings, Studs and Buttons.

**Shafer & Douglass.**—Manufacturers of all kinds of Seal, Stone, Turquoise, and fancy rings. No. 7 Maiden Lane, N. Y.

**Sinnock & Sherrill.**—Manufacturers of Stone Rings. No. 3 Maiden Lane, N. Y.

**Thuerner & Church**—Manufacturers of Fine Gold Rings. No. 9 Maiden Lane, N. Y.

**Wood, J. R.**—Gold Ring Manufacturer of 14 John Street, has assumed his son into partnership. The firm will now be J. R. Wood & Son.

#### Hair Jewelry.

**Moutoux, Wm. E. & Co.**—Manufacturers of Fine Hair Mountings in Gold. Gravel catalogues for the trade. 81 Nassau St., Rooms 1 and 2. Finest work and lowest prices.

**Sauter, L.**—Manufacturer of Fine Gold and Hair Jewelry and Device Work. Pattern Book sent on application. No. 1 Maiden Lane, N. Y.

**Schwencke O.**—Manufacturer of Fine Hair Jewelry Orders from the country promptly attended to. No. 43 Maiden Lane.

#### Jewelry Cases, Fancy Boxes, Etc.

**American Morocco Case Co.**—7 and 9 Bond St., N. Y., make a specialty of Rich Jewelry and Silverware Cases for the fine Retail Trade. Also Improved Trays for Watches, Rings, etc.

**Bayle & Fe's**—Manufacturers of Jewelry and Silverware Boxes, Jewelers' Traveling Cases, etc. Trays for Show Cases and Trunks, Ladies' and Gent's Jewel, &c., &c., 80 Nassau street, N. Y.

**Braun, Chr. E.**—Manufacturer of Fine Jewelry Boxes and Trays for Show Cases and Trunks. No. 62 Chatham Street, New York. Trays for Show Cases and Trunks a Specialty.

**Bricka, C. A.**—Manufacturer of Morocco Cases for Cutlery, Silverware, Jewelry, etc. Sample Cards and Rolls. Cases in Rosewood, Black Walnut, etc. 52 Nassau Street, New York.

**Dennison Mfg Co.**—Manufacturers of Morocco, Plush and Velvet Jewelry and Silverware cases. New York, Boston, Philadelphia, Chicago, Cincinnati and St. Louis.

**Ettlinger, L. & Sons.**—Manufacturers of Fine Cases for Jewelry, Watches and Silverware. Trays for Travelers and Show Cases. Cases to Order a Specialty. No. 80 Nassau St., N. Y.

**Haensler, Chas. C.**—Manufacturer of Fine Morocco Cases for Jewelry and Silverware, Toilet Boxes, etc. Trays for Show Cases and Windows. 14 John Street, New York.

**Hebbard & Brother**—Manufacturers of Jewelry and Silver Ware Cases, and Fancy Wood Chests for Tea Sets and Flat Ware, 2 Bond Street, near Broadway, New York.

**Jackson, S. C.**, 180 Broadway, N. Y., Manufacturer of Fine Cases for Jewelry, Silverware, &c.

**Kohn, Solomon & Co.**—Manufacturers of Fine Morocco Cases for Jewelry, Watches, etc. 43 Maiden Lane, New York.

**Lauten, Edw. A. & Co.**—No. 4 Great Jones St., Manufacturers of Fine Velvet, Brocade, Plush and Morocco Boxes, Patent Ring, Ear Ring and Gent's Scarf Pin Trays, Patent Watch and Bracelet Blocks, Window Decorations, etc.

**Metropolitan Fancy Box and Leather Goods Manufacturing**—Makers of Plush, Velvet, Satin and Leather Cases for Watches, Jewelry, Silverware, etc. 75 and 77 Nassau Street, N. Y.

**New England Morocco Case Co.**—Makers of Jewelry and Silverware Cases of every description. 220 Chapel Street, New Haven, Conn.

**New York Morocco Case Co.**—Cases for Jewelry, Watches, Silverware. Boxes and Trays for Jewelers' Travelers. Show Cases and Window Fittings. No. 69 Nassau Street, New York.

**Sauer & Schroeter**—Successors to Loehr & Koerner, Manufacturers of Morocco, Velvet, Satin, Jewelry, Watches and Silverware Cases, Jewel, Work Boxes, etc., Fancy Trays and Store Fittings to order. 96 Liberty St.

**Schwarz, N.**—Manufacturer of fine Cases for Jewelry and Silverware, 866 Broadway, near 17th street, N. Y.

**Welch & Miller**—169 Broadway. Manufacturers of fine Morocco, Velvet, Russia, Brocade and Plush Jewelry Cases. Trays of every description; Jeweler's Cotton and Twine.

**Wiggers & Froelick**—No. 60 Nassau street—Manufacturers of Cases for Jewelry, &c., of every description. Trays for Show-cases, Stands for Show-windows, etc.

#### Jewelers' Findings.

**Dennison Mfg Co.**—Paper Jewelry Boxes, cards, tags, pink and white cotton, etc. etc. New York, Boston, Chicago, Cincinnati, Philadelphia, St. Louis.

**Ettlinger, L. & Sons.**—Manufacturers of Jewelers' Paper Boxes and Findings. Morocco Paper, Satin or Plush Lined Wooden Corner Stops Jewelry and Silverware Boxes. 80 Nassau Street, New York.

**Lehmann, Ludwig**—Manufacturer of Jewelers' Findings. Specialty, Fine Paper Boxes for Jewelers and Silversmiths, 122 Fulton St., N. Y. City.

**Valfer, S. & Co.**—Manufacturers and Dealers in Jewelers' Boxes, Tags, Cards, Paper and Findings. Trays a specialty. Office and Salesroom, 66 Nassau street, New York.

#### Jewelry Manufacturers.

**Aikin, Lambert & Co.**—Manufacturers General stock of Reliable Jewelry, 23 Maiden Lane.

**Alling, Isaac A. & Co.**—Manufacturers of Fine Gold Jewelry. Sets, Lace Pins, Ear Rings, Studs, Collar Buttons and Scarf Pins. Specialties: Wire Bracelets, Bangles, American Lever Sleeve Buttons. Bryant Building, Nassau and Liberty Streets, N. Y. Factory, Newark, N. J.

**Alling & Co.**—Manufacturers of Fine Jewelry, No. 170 Broadway, corner Maiden Lane, New York. Manufactory, Newark, N. J.

**Baldwin, Sexton & Perterson**—Manufacturers of Rich Jewelry, 692 and 694 Broadway, N. Y.

**Ball, W. H.**—Manufacturer of Gold Jewelry. Bracelets and Bangles of all kinds a specialty. 9 John Street, N. Y.

**Barthman, Straat & Co.**—Manufacturers of Fine Jewelry. Roman Goods, Rings, Diamonds. No. 43 Maiden Lane.

**Bissinger, Philip & Co.**—Importers of Diamonds, Pearls and Precious Stones. Sole Agents for the Bohemian Garnet Jewelry, Blue Enameled Lockets. 22 John St., N. Y.

**Brown, Thos. G. & Sons**—Man'rs of Rich Jewelry Necklaces, Locketts, Bracelets, Sleeve Buttons, etc., 5 Bond Street, N. Y.

**Bryant & Bentley**—Manufacturing Jewelers. Rings a specialty. 12 Maiden Lane

**Carter, Sloan & Co.**—Manufacturing Jewelers, 15 Maiden Lane, New York.

**Champanois & Co.**—No. 5 Maiden Lane, manufacturers of Engraved and Enameled Gold goods, in Sets, Ear Knobs, Bracelets, Studs, Lace and Shawl Pins, Jet cluster and Onyx goods, also "Best Lever" Sleeve Buttons.

**Chatellier, Joseph F.**—Manufacturing Jeweler, No. 694 Broadway, N. Y.

**Churchill, Lewis & Co.**—Manufacturers of Fine Jewelry. 692 Broadway, cor. Fourth St., N. Y.

**Cook, George W.**—Manufacturer of Fine Jewelry and Locketts, 191 Broadway (over Mercantile Bank,) N. Y.

**Ootle S. Co.**—Manufacturers of Fine Jewelry. Waltham Building, 5 Bond Street, N. Y.

**Cox & Sedgwick**—Manufacturers of fine Onyx and Colored Jewelry. 26 John St., New York

**Day & Clark**—Manufacturers of Fine Jewelry, Lace Pins, Ear Rings, Studs, Locketts, &c., 10 Maiden Lane, New York.

**Geoffroy, Arthur R. & Co.**—Manufacturing Jewelers. Novelties in Diamond Goods. No. 23 Maiden Lane, N. Y.

**Greene Wm. C. & Co.**—Goldsmiths; Manufacturers of Rich Sets in Taper Wire Coral. Office, 192 Broadway.

**Griffith, H.**—Manufacturing Jeweler. Gold and Plated Jewelry. Scarf Pins a specialty. Nutry Alley, near Concord St., Brooklyn, N. Y.

**Groschel & Rcsman**—Manufacturers of Fine Jewelry. No. 27 John Street, N. Y.

**Hale, S. W. & Co.**—Manufacturers Rich Jewelry, Whiting Building, Broadway and 4th Street.

**Hartmann, P.**—Manufacturer & Importer of Fine Gold, Diamond, and Filigree Silver Jewelry, No. 36 Maiden Lane. P. O. Box 2,454.

**Hedges, A. J. & Co.**—Manufacturing Jewelers, 6 Maiden Lane.

**Henderson & Winter**—Jewelers, No. 15 Maiden Lane, New York. Specialties—Stone, Cameo, Onyx, Amethyst, Topaz, Pearl and Turquoise Rings.

**Hunt & Owen.**—Manufacturing Jewelers. Office 3 Maiden Lane.

**Kipper, Vogel & Co.**—Manufacturing Jewelers, 17 Maiden Lane, New York.

**Kremetz & Co.**—Manufacturing Jewelers, No. 182 Broadway, N. Y.

**Kuhn, Doerflinger & Co.**—Manufacturers of Enameled and Roman Band Bracelets, also Fine Locketts Pendants and Lace Pins. 18 John street.

**Miller Bros.**—Manufacturers of Fine Jewelry, Locketts, Sleeve Buttons, Studs, &c., 7 Maiden Lane, N. Y.

**Moore & Horton.**—11 Maiden Lane, Manufacturing Jewelers, Rings, Studs, Collars and Sleeve Buttons, Pins, Ear-rings, &c.

**Muhr's, H., Sons.**—Manufacturing Jewelers. Solid Gold and Filled Rings a specialty. Also Manufacturers of the celebrated Crown Filled Watch Case. 16 Maiden Lane, N. Y.

**Mulford & Bonnet**—No. 21 Maiden Lane, New York.

**Owen, G. & S. & Co.**—Manufacturing Jewelers. Office, No. 3 Maiden Lane.

**Richardson, Enos & Co.**—Manufacturers of Fine Gold Jewelry, Gold Chains, Locketts, Crosses and Necklaces. Colored and Etruscan Work. No. 23 Maiden Lane, New York.

**Richardson, J. W. & Co.**—Manufacturers of Jewelry, Masonic and other Emblems. 196 Broadway, N. Y. Manufactory, Providence, R. I.

**Riley, J. A. & Co.**—Manufacturing Jewelers Etruscan Gold and Roman Bracelets, Lace Pins, Ear Rings, Scarf Pins, Brooch Pins, etc. Nos. 7 and 9 Bond Street, N. Y.

**Ripley, Howland & Co.**—Manufacturers of Fine Jewelry and Platinum Tipped Diamond Settings. No. 17 Maiden Lane, N. Y.

**Sauter, L.**—Manufacturer of Fine Jewelry, Solid Stone Rings and Studs a specialty. Jobbing for the trade. 1 Maiden Lane, New York.

**Schwencke, Wm.**—Manufacturing and Jobbing Jeweler. Repairing a specialty. Orders promptly attended to. No. 43 Maiden Lane, N. Y.

**Sexton & Cole**—Manufacturing Jewelers, Colored Gold and Onyx Goods a specialty. No. 30 Maiden Lane.

**Sheaffer, W. H. & Co.**—Manufacturing Jewelers, Specialty Bangles and Bracelets, 15 John St., N. Y.

**Stites' Sons, E.**—Manufacturers of Fine Jewelry. No. 14 John Street, N. Y.

**Street, Geo. O. & Sons.**—Established 1837. Makers of Fine Jewelry, strictly first-class goods of our own make. No. 15 John Street, New York.

**Thoma, Ernest**—Manufacturer of Fine Jewelry, Sleeve Buttons, Rings, Ear-rings, &c. No. 173 Broadway, N. Y. Factory, Hackensack, N. I.

**Ward, Thos. M.**—Manufacturer of Fine Jewelry, Diamond Mountings a specialty. No. 25 John Street, N. Y.

**Wienhold, Joseph**—Manufacturer of Fine Jewelry Diamond Mountings a specialty. 24 John St.

**Woglom & Miller**—Manufacturers of Black Onyx Goods exclusively. 32 & 34 John Street, N. Y.

#### Jewelry—Rolled Plate.

**Blackinton, W. & S.**—Manufacturers of the W. & S. B. Rolled Plated Chains. No. 11 Maiden Lane.

**Frick, John & Co.**—Fine Rolled Plate Jewelry of all kinds. Repairing of every description. 21 and 23 Maiden Lane, N. Y.

**Mauran, J. T.**—Manufacturer of Fine Rolled Plate Jewelry, No. 15 Maiden Lane, N. Y.

**Richards, E. Ira & Co.**—Manufacturers of Fine Rolled Plate Jewelry, No. 200 Broadway, N. Y.

#### Jewelers' Tools, etc.

**Fisher, James J.**—Dealer in Watchmakers' and Jewelers' Materials, Files, Tools, Silk Guards Spectacles, etc. 697 Broadway, N. Y.

**Friedenthal, A. & Co.**—Importers and jobbers of Watchmakers' and Jewelers' Tools, Materials, etc. 43 Maiden Lane, N. Y.

**Friedlander, R. & L.**—Importers of Watchmakers' Tools and Materials. 65 & 67 Nassau Street. Branch Office, 264 Bowery.

**Kurtz, F. P.**—Manufacturer of Jewelers Machinery, Tools, Rolling Mills, Presses, Polishing Lathes, &c. 97 Cliff St., N. Y.

**Levy, Dreyfus & Co.**—Importers and Jobbers of Watchmakers' and Jewelers' tools and materials of every description. 11 Maiden Lane, N. Y.

**Montgomery & Co.**—Importers of and Dealers in Manufacturing Jewelers' Tools and Materials of every description, 105 Fulton street, New York.

**Reichhelm, E. P. & Co.**—Importers of Jewelers' Tools, Files, etc. Manufacturers of Brushes and Buffing wheels; also Patent Gas Furnaces for Melting, Plating, Enamelling, Annealing, etc. 80 Nassau St., N. Y.

#### Lapidaries.

**Fox, M. & Co.**—Practical Lapidaries, No. 1 Maiden Lane, New York.

**Graham & Co.**—Practical Lapidaries, Cutters and Polishers of all kinds of Precious Stones. Miners' Relics Cut, Polished and Mounted. Miniature, Locket and Clock Glasses. 80 Nassau St., N. Y.

**Kordmann & Michel.**—Lapidaries. Dealers in Precious Stones. Cutting and Polishing Rubies, Sapphires and other Gems a specialty. Drilling done promptly. 59 Nassau St., N. Y.

**Korn, Ph.**—Lapidary. Importer of Precious and Imitation Stones, No. 63 Nassau street, between Maiden Lane and John street, New York.

#### Masonic Jewelry.

**Luther, John F.**—79 Nassau Street. Manufacturer of Fine Presentation Jewels for all Societies. Knights Templars, Crosses, Badges, &c.

**Wilkinson, C. B.**—Manufacturing Jeweler, 8 John St., N. Y. Medals, Badges and Masonic Jewelry, a specialty. Designs furnished free upon application.

#### Musical Instruments.

**Stratton, Jno. F. & Co.**—Importers and Wholesale Dealers in all kinds of Musical Merchandise, Music Boxes, Musical Novelties, etc. 49 Maiden Lane, N. Y.

#### Optical Goods.

**Friedlander, R. & L.**—65 and 67 Nassau Street. Dealers in Optical Goods.

#### Opticians.

**Burbank Man'g Co.**—Manufacturers of Spectacles and Eye Glasses of all descriptions, in gold, silver, etc., 14 Maiden Lane, N. Y.

**DuBois, Geo. W. & Co.**—Importers of Watches and Optical Goods. 36 Maiden Lane, N. Y.

**Levy, Dreyfus & Co.**—Importers of Spectacles and Eye Glasses and Optical Instruments of every description, No. 11 Maiden Lane, N. Y.

**Lorsch, Albert.**—Manufacturer of the Patent Accommodating Spectacles and Eye Glasses in Gold, Silver and Steel, and other Optical Goods, 37 Maiden Lane, N. Y.

**Spencer Optical Manufacturing Co.**—Gold, Silver, Steel, Nickel and Plated Spectacles; Gold, Celluloid, Steel, Nickel and Rubber Eye Glass and Opera Glasses. 13 Maiden Lane, N. Y.

#### Paper Boxes.

**Waterbury Paper and Box Co.**, 27 to 35 Canal St., Waterbury, Conn., Manufacture Jewelers' and Silversmiths' Fine Paper Boxes. Quality guaranteed to be equal to the best made.

#### Precious Stones, &c.

**Bishop, Victor & Co.**—33 Maiden Lane, Importers of Precious Stones, Cameos, &c. Also Manufacturers of Coral Jewelry.

**Bissinger, Philip & Co.**—Importer of Diamonds, Pearls and Precious Stones. Agent for the Bohemian Garnet Goods. Blue Enamelled Locketts. No. 22 John St., N. Y.

**Briedenbach, R. A.**—Importer of Black Onyx, Diamonds, Pearls, Turquoise, Cameos, Sardonyx, Amethysts, Garnets, Topaz, Opals, Rubies, Sapphires, Hematite Balls, Foil Brilliants, Cat's-Eyes, Tiger Eyes, Doublets, Cabinet Specimens, etc. 85 Nassau Street, New York.

**Daue, Wm. & Co.**—Importer of Precious and Imitation Stones. No. 202 Broadway New York.

**Fox, M. & Co.**—Importers of Diamonds and other Precious Stones, No. 1 Maiden Lane, N. Y.

**Gruet, Jules.**—Importer of all Grades of Real and Imitation Stones. 14 John St., N. Y.

**Hahn & Co.**—Importers of Precious Stones, Cameos, Onyx, Pearls, Intaglios, Amethysts, Garnets, etc. 64 Nassau Street, New York.

**Kahn, L. & M. & Co.**—Importers of precious and imitation stones. 10 Maiden Lane, N. Y.

**Kipling, E. E.**—Importer of Precious and Imitation Stones. Manufacturer of the Patent Foil Solid Metal Back Rhine Stone Brilliant. No. 6 Maiden Lane, N. Y.

**Kipling, R. A.**—Precious and Imitation Stones, No. 24 Maiden Lane, N. Y. Manufacturer Cameos, Agates, Onyx, Etc., Oberstein, Germany. Commission Merchant, 49 Rue De L'Echiquier, Paris.

**Lorsch, Albert.**—Importer of Precious Stones, 37 Maiden Lane, N. Y.

**Stirn, Max & Bro.**—Importers of Black Onyx, Cameos, Turquoise, Half Pearls, Sardonyx, Amethysts, Topaz, Garnets, Opals, Rubies, Sapphires, Cat's-Eyes, and all other imitation stones, 3 Maiden Lane, New York.

#### Safes.

**Butler, W. H.**—Fire and Burglar Proof Safes, 291 Broadway, N. Y.

#### Silverware.

**Gorham Manufacturing Co.**—Union Square.

**Knowles, J. B. & S. M.**—Manufacturers of Sterling Silverware, 20 Maiden Lane, N. Y. Factory, Providence, R. I.

**Shiebler, Geo. W.**—Manufacturer of Sterling Silverware. No. 8 Liberty Place, near Maiden Lane, N. Y.

**Whiting Manufacturing Co.**—Makers of Sterling Silver Ware. Broadway cor. 4th Street, N. Y.

**Wood & Hughes.**—Manufacturers of Fine Silverware. 16 John Street, N. Y.

#### Silver Filigree Jewelry.

**Cuppia, L. A.**—Manufacturer of Solid Silver Novelties, and Importer of Silver Filigree, 19 Union Square.

**Francesconi, Guido.**—Importer of Silver Filigree Jewelry, 196 Broadway, New York.

**Hartmann, P.**—Manufacturer of Silver Filigree Jewelry. 36 Maiden Lane, N. Y.

#### Silver Plated Ware.

**Holmes, Booth & Haydens.**—Manufacturers of Silver-Plated Ware. 47 Chambers Street.

**Manhattan Silver Plate Co.**—Manufacturers of Silver Plated Ware. Showrooms, 23 John St. Factory, 301 to 305 East 22d St., cor. 2d Ave. Address all communications to Factory.

**Middletown Plate Co.**—Manufacturers of Superior Electro-Plate. Factories, Middletown, Conn., salesroom, 13 John Street.

**Rogers, Smith & Co.**—Manufacturers of Fine Electro Plated Ware. No. 46 E. 14th St., N. Y.

**Simpson, Hall, Miller & Co.**—Manufacturers of fine Silver-Plated Ware. No. 36 E. 14th Street.

**Schade, Henry.**—Manufacturer of White Metal and Plated Ware. Nos. 56 & 58 Ainslie Street, Brooklyn, E. D., N. Y. Price list and catalogue furnished on application.

**The Derby Silver Co.**—Manufacturers of Finest Quadruple Silver Plated Ware, Birmingham, Conn. New York office, 25 Maiden Lane.

**Webster, E. G. & Bro.**—Manufacturers of Fine Silver-Plated Ware. Office and warerooms, 14 Maiden Lane, N. Y.

#### Show Cases, Etc.

**Smith, B. & W. B.**—Manufacturers of Patent Improved Dust Proof Show Cases, with Perpendicular Sliding Doors. No. 220 W. 29th St., N. Y.

#### Spectacle Case Manufacturers.

**Bertine, P. D.**—Manufacturer of Spectacle and Eye-Glass Cases. 139 William Street, near Fulton St., New York.

**Koenen, A. & Bro.**—Manufacturers of Leather Spectacle and Eye-Glass Cases for the Jobbing Trade only. 81 Nassau St., N. Y.

#### Stem Winding Attachments.

**Abbott, Henry** Maker of Stem Winding Attachments, No. 4 Maiden Lane, N. Y.

#### Swivels and Spring Rings.

**Schwartz, V. & Co.**—Manufacturers of Gold Swivel and Chain Trimmings. 33 Barclay Street, New York.

#### Thermometers, Etc.

**Tagliabue, Giuseppe.**—Manufacturer of Thermometers, Barometers and Hydrometers. Patentee and sole manufacturer of the U. S. Standard Hydrometer. 302 Pearl Street, near Beekman.

#### Thimble Manufacturers.

**Burbank Manufg Co.**—Manufacturers of Gold and Silver Thimbles, 14 Maiden Lane, N. Y.

**Ketcham & McDougall.**—Improved Gold and Silver Thimbles, Bryant Building, N. Y.

**Simons Bro. & Co.**—Manufacturers of Gold and Silver Thimbles, 611 and 613 Sansom Street, Philadelphia.

**Woglom & Miller.**—Sole Agents for the "Prime" Thimbles in Gold and Silver, manufactured by Ezra C. Prime. 34 John Street, N. Y.

#### Trunks.

**Crouch & Fitzgerald.**—Manufacturers of Trunks and Articles for Travelers' use. 1 Cortlandt St., 556 Broadway, and 723 Sixth Ave., N. Y.

#### Watch Companies.

**American Watch Co.**—Robbins & Appleton, No. 5 Bond Street, N. Y.

**Illinois Watch Co.**—Springfield, Illinois. 21 Maiden Lane, N. Y. and 71 Washington Street, Chicago, Ills.

**The E. Howard Watch and Clock Co.**—Cor. Maiden Lane and Nassau Street, N. Y.

**Waterbury Watch Co.**—Manufacturers of the Waterbury Watch. Factory, Waterbury. Office, 52 Maiden Lane, N. Y.

#### Watch and Chronometer Jeweler.

**Queen, James.**—Watch and Chronometer Jeweler and Pallet Maker, 78 Nassau Street, room 8. Pivots inserted in Pinions, Balance, Staffs, etc.

**Robert, Henry L.**—Practical Chronometer and Watch Jeweler, and Adjuster of all kinds of Escapements. 71 Nassau Street (Room No. 3). All kinds of Pallet and Hole Jewels for Chronometer Watches and Compasses done in the best manner.

**Wennstrom, John.**—Watch, Chronometer and Clock Jeweling, Jewel Gauges, Ruby and Sapphire Draw Plates; Diamond Charged Polishing Stones for Jewel Settings; Pivots inserted in Pinions. 2 Dutch Street, N. Y.

#### Watch Importers, Etc.

**Abry, Chas. Leo.**—Importer and Manufacturer of Swiss Watches of all grades. 63 Nassau Street.

**Aikin, Lambert & Co.**—Importers of Watches. Sole Agents for Paul Breton & Chas. Latour, Geneva. A general line of reliable Swiss Watches, Watch Cases, etc. 23 Maiden Lane, N. Y.

**Bartens & Rice.**—20 John Street, Importers of Watches and sole agents in the United States for the celebrated Nicole, Nielsen & Co. Watches.

**Cross & Beguelin.**—Importers of Watches, Watch Tools and Materials, dealers in American Watches, No. 21 Maiden Lane, N. Y.

**Droz, Henry E.**—Importer of Watches, and Watch Case Manufacturer. Agent for the "E. Perre-gaux" Watch, and jobber in American Watches No. 92 Fulton Street, N. Y.

**Freund Max & Co.**—Importers of Watches, Jewelry and Precious Stones, 8 Maiden Lane, N. Y.



**Gagnebin, Chas.**—Importer of all kinds of Swiss, and Dealer in American Watches. 4 Maiden Lane, N. Y. Agent for Ulysse Breting's Fine Chronometers, Chronographs, Anchors, &c.

**Gallet, Julien.**—Importer of Watches. No. 1 Maiden Lane.

**Ginnel, Henry.**—Importer of Watches, Tools and Materials, 31 Maiden Lane, N. Y. P. O. Box 2967

**Hyde's Sons, John E.**—Wholesale Commission Agents, only for Jules Jurgensen, of Copenhagen; Jules Monard, of Geneva; and for other makers of all qualities of Watches, 22 Maiden Lane.

**Keller, L. H. & Co.**—Successors to G. A. Huguenin, Importers of Fine Watch and French Clock Materials, No. 64 Nassau Street, N. Y.

**Mathey Bros. & Mathez.**—Importers of Fine Watches and Sole Agents for the **H. L. Matile's** Watches. No. 16 Maiden Lane.

**Robert, J. Eugene.**—No. 30 Maiden Lane, New York. Agent for Louis Audemar's celebrated watches.

**Schumann, Chas. W.**—No. 24 John Street, New York. Importer of Fine Diamonds, Watches, etc. Sole Agent in the U. S. for the celebrated "Lange" Dresden Watch, also Sole Licensee for Trench's Differential Dial.

**Schwob, Adolphe.**—Manufacturer and Importer of Watches, 11 Maiden Lane, N. Y.

**Strasburger, Louis & Co.**—Importers and Makers of Watches of every description, 15 Maiden Lane.

#### Watch Cases.

**Dueber Watch Case Mfg Co.**—Manufacturers of Gold and Silver Watch Cases, Bryant Building, N. Y. Factory, Newport, Ky.

**Fahys, Joseph.**—Manufacturer of Watch Cases and Dealer in American Movements, 38 Maiden Lane.

**Glatz, Chas.**—Manufacturer of Silver Watch Cases, Bryant Building, cor. Nassau and Liberty Sts.

**Keller & Untermeyer.**—Manufacturers of Watch Cases with Raised Gold Ornaments, 9 Maiden Lane, N. Y.

**Ladd Watch Case Co.**—Manufacturers of the Ladd Patent Stiffened Gold Watch Cases, etc., 11 Maiden Lane, N. Y. Factory, 58 Eddy Street, Providence, R. I.

**Martins & Tissot.**—Manufacturers of Gold Watch Cases. No. 15 Maiden Lane, N. Y.

**The Brooklyn Watch Case Co.**—Manufacturers of the celebrated Eagle Case. 40 Maiden Lane.

**Willemin Watch Case Co.**—Makers of Gold Watch Cases. Raised Gold Ormentation and Jurgensen style of Engine Turning, 109 Sands Street, Brooklyn, N. Y. 16 Maiden Lane, N. Y.

#### Watch and Chronometer Repairers.

**Cerf, B.**—Practical Watchmaker and Repairer, No. 10 John Street, N. Y. Repairing and adjusting of Fine Watches done for the trade. All kinds of escape and stem-winding wheels cut to order.

**Goepf, Frederick A.**—Practical Watchmaker. Repairing of every description for the Trade. 25 Maiden Lane, N. Y. In office of H. Garland, Engraver.

**Heinrich, H. H. & Co.**—Sole Manufacturers of H. H. Heinrich's Patent Auxiliary Balance, and Adjusters and Repairers of Fine Watches and Chronometers. 12 John Street, N. Y.

**La Croix, J. H.**—(Late with Benedict's Time,) Watch and Clock Maker, 21 John Street, N. Y. Clocks of every description Repaired for the Trade.

**Lesperance, Theo.**—Watchmaker and Wheel Cutter. No. 1 Maiden Lane, New York. With Julien Gallet.

#### Watch Case Repairers.

**Feinier, Joseph A.**—Watch Case Maker and General Repairer. Specialty in fine Gold and Silver Cases. Jobbing promptly attended to. Nos. 4 and 6 John St., N. Y.

**Perret & Jardon.**—Watch Case and Spring Repairers. No. 80 Nassau St. (top floor), N. Y. Cases and Springs of all kinds neatly repaired.

**Tarbox, Hiram.**—Watch Case Repairing, Springing, Polishing and Engine Turning. 1874 North Fourth Avenue, bet. 176th and 177th Sts., N. Y. Express Packages should be sent to 92 Fulton Street.

#### Watch Glasses, Shades, Etc.

**Brown, Edwin H.**—No. 85 Nassau Street, Imported and Own Manufacture Watch Glasses, Flat, Flat Concave, Concave, Convex and fine Genevas, Fine fitting solicited.

#### Watches, Diamonds and Jewelry.

**Alford, C. G. & Co.**—Manufacturers. General line fine and Reliable Goods. Specialties in Onyx Goods and Chain. 200 Broadway, New York.

**Cohn, J. J.**—Importer and Manufacturer of Whitby Jet, Rubber and Pearl goods. Gold and Rolled-plate Jewelry, etc. 12 Maiden Lane, New York.

**Durfey & Reynolds.**—Successors to Durfey & Shiebler, Watches, Diamonds, Jewelry. No. 9 John Street, (up-stairs) New York.

**Friedman, Saml.**—Wholesale Dealer in Watches and Jewelry, 42 Maiden Lane, N. Y.

**Goddard, John M.**—Manufacturing Jeweler,—Seal Rings and Fine Lockets a specialty, No. 3 Maiden Lane, N. Y.

**Greason J. R. & Co.**—Successors to Arthur, Rumrill & Co., 182 Broadway. Manufacturers of Fine Jewelry and Gold Chains, also Diamond Mountings.

**Haskell, H. C.**—Manufacturing Jeweler. Seal Rings a specialty. Special attention to Jobbing of every description. 12 John street.

**Herzog, Louis & Co.**—Importers of Watches, Dealers in Diamonds and Jewelry, 52 Maiden Lane, N. Y.

**Hirsch Bros.**—Dealers in Watches and Diamonds and Manufacturers of Jewelry, No. 23 Maiden Lane, N. Y.

**Jandorf, P. & Bro.**—Importers of Watches and Jewelry, 196 Broadway.

**Kennedy, Frank S.**—Manufacturer and Wholesale Dealer in Jewelry and Gold and Silver Thimbles. No. 13 Maiden Lane, New York.

**Lissauer & Sondheim.**—Wholesale Jewelers and Jobbers in American Watches, No. 12 Maiden Lane, N. Y.

**Marx, Kossuth & Co.**—Importers of Watches and Dealers in Jewelry. 39 Maiden Lane, N. Y.

**May, Henry.**—Importer and Wholesale Dealer in Watches and Diamonds, and Manufacturing Jeweler. 19 John St., N. Y.

**Mayer, B.**—Manufacturer of Fine Jewelry, and Dealer in Watches, 71 Nassau street, cor. John street, New York.

**Myers, S. F. & Co.**—Manufacturing and Wholesale Jewelers—all grades. Importers of Watches. Illustrated Catalogue to the trade, 179 Broadway, N. Y.

**Oppenheimer Bros. & Veith.**—Dealers in Watches and Diamonds, and Manufacturing Jewelers, No. 35 Maiden Lane.

**Scott, J. T. & Co.**—Importers of Watches, and Manufacturers of Jewelry, and Jobbers of all Grades of American Watches, 4 Maiden Lane.

**Smith & Knapp.**—Wholesale Dealers in American and Swiss Watches, Diamonds, Gold and Plated Jewelry and Gold Chain. 182 Broadway, N. Y.

**Steele, J. W.**—Successor to Brainerd, Steele & Co., Manufacturer of Fine Jewelry and Brainerd's Patent Lockets. No. 9 Maiden Lane, N. Y.

**Stern Brothers & Co.**—Importers of Swiss Watches and wholesale dealers in American Watches, &c., 39 Maiden Lane.

**Stern & Stern.**—Dealers in Watches, Jewelry and Diamonds. No. 6 Maiden Lane, N. Y.

**Stites, D. H. & Son.**—Manufacturers of Fine Jewelry, Rolled Plated Goods and Chains, Parisian Diamond Rings, Studs and Earrings a specialty. 41 Maiden Lane, N. Y.

**Strauss, Jacob.**—Full Line of Gold and Plated Jewelry, and Importer of Watches. 18 John Street, New York.

**Thrall, E. A.**—Wholesale Dealer in Watches and Jewelry. No. 1 Maiden Lane, N. Y.

**Trier Bros.**—Importers of Gamet, Whitby Jet and Amber Jewelry, Silk Guards, Opera, Field and Marine Glasses, Pearl Card Cases. Also a full line of Gold and Plated Jewelry. 15 Maiden Lane, N. Y.

**Wheeler, Parsons & Hays.**—Manufacturers of Fine Jewelry, Watch Cases, Gold Chains, &c. and Dealer in American and Swiss Watches, No. 2 Maiden Lane, N. Y.

**White, N. H.**—Jobber in American-Waltham Watches and Chronographs. Waltham make of 10-k., 14-k. and 18-k. Gold and Sterling Silver Cases; Filled Gold Cases. 11 Maiden Lane.

#### Watch Tools, etc.

**Keller, L. H. & Co.**—Importers of Watchmakers' and Jewelers' Tools, Materials, etc. 64 Nassau Street, N. Y.

**Zimmern, Henry.**—Importer of Watch Materials, Tools, and Optical Goods, No. 8 Maiden Lane, (first floor.) Sole Agent for A. Hugenin & Gravier, Mainsprings, New York.

#### PHILADELPHIA

**Bennett, Jacob & Son.**—Diamond Setters and Manufacturing Jewelers, 925 Chestnut St.

**Bernard & Co.**—Manufacturers of Fine Roman and Etruscan Jewelry. Designs of every description made to order, 123 & 125 South Eleventh Street, Philadelphia.

**Booz & Co.**—Manufacturers of Gold and Silver Watch Cases and Jewelry, 108 South 8th St., Philadelphia.

**Conover David F. & Co.**—American Watches, Wholesale Salesroom, Southeast corner 7th and Chestnut Streets, Philadelphia.

**Herold, Chas P.**—Successor to Hildebrandt, Herold & Co., Manufacturing Jeweler and Diamond Setter. Diamonds. 916 Chestnut Street.

**Krieder, Peter L.**—Manufacturer of Sterling Silver Ware. 618 Chestnut Street, Philadelphia.

**McCall & Newman.**—Manufacturing Jewelers. Makers of the Original Gold Crown Filled Rings. No. 625 Arch St., Philadelphia.

**Morgan & Headly.**—Manufacturing Jewelers. Cameo Sets, Gold Sets, Roman Lockets, Rings, Coral Sets and a general line of rich goods. Corner 10th and Chestnut Streets, Philadelphia.

**Muhr's, H., Sons.**—Manufacturing Jewelers. Solid Gold and Filled Rings a specialty. 633 and 635 Chestnut Street, Philadelphia. 1½ Maiden Lane, New York.

**Peters, Reese S.**—Manufacturer of Patent Rolled Plate or Filled Watch Cases, Dealer in American Movements, 308 Chestnut Street, Philadelphia.

**Rosenthal, G. F. C.**—Manufacturing Jeweler and Diamond Setter. Engraving and Designing of Monograms a specialty. No. 917 Sansom Street.

**Scherr, L. A. & Co.**—Wholesale Dealers in Watches Silver-Plated Ware, Spectacles, Fancy Goods, Watch Materials, etc. 726 Chestnut Street.

**Sheafer, W. H. & Co.**—Manufacturing Jewelers. Specialty: Band Bracelets. Factory, 612 and 614 Chestnut street, Philadelphia. Office, 15 John street, New York.

**Simons, Brother & Co.**—Manufacturers of Fine Jewelry, Cans, Thimbles, Chains. 611 and 613 Sansom Street.

#### CHICAGO.

**American Watch Company.**—of Waltham, Mass. No. 102 State Street, Chicago.

**Clapp & Davies.**—Wholesale Jewelers, 63 and 65 Washington Street. Catalogue and price list issued to watchmakers and jewelers.

**Dennison Manufacturing Co.**—Manufacturers of Jewelers' Paper Boxes, Morocco Cases, Tags, Cards, Pink and White Cotton, Tissue Papers, Sealing Wax, &c., &c., 102 Madison St., Chicago. Boston, New York, St. Louis, and Philadelphia.

**Gilbert, Wm. L., Clock Co.**—Manufacturers of Clocks, Regulators, and Time Pieces, and Clock Material of every description, 54 and 56 Madison Street, Chicago.

**Giles, Bro. & Co.**—Manufacturers and Jobbers in Watches, all classes of Jewelry, Materials, Clocks, Silver Ware, &c. Illustrated catalogues furnished to dealers on application. 101 & 103 State St.

**Wathier, Joseph P.**—Watchmakers and Jewelers for the trade, and Wholesale Dealers in Watch Materials, Tools, etc. 178 West Madison Street, Chicago, Ill. Send for price list.

#### NEWARK.

**Baker & Co.**—Gold, Silver and Platinum Refiners, Assayers and Sweep Smelters. 408 New Jersey Railroad Avenue, cor. Murray St., Newark, N. J.

**Diefenthaler Bros. & O'Donnell.**—Manufacturers of Fine Jewelry, Lace Pins, Ear Rings and Patent Spring Bangles a Specialty. 36 Crawford Street, Newark, N. J.

**English & Miller**—Manufacturers of Gold Jewelry, Diamond and Fancy Stone Rings, Roman Lockets, Bangle and Flexible Bracelets, Knife Edge Lace Pins and Sets, Scarf Pins and Link Buttons. 61 and 63 Hamilton St., Newark.

**Felger, F. & F.**—Manufacturing Jewelers. Specialties:—Roman Band Bracelets, Lace Pins, Scarf Pins, Ball and Fancy Ear Rings. No. 477 Washington Street, Newark, N. J.

**Fiedler, Herrman**—Successor to Kunze & Fiedler, Engraver, Die Sinker and Press Tool Maker, 363 Market Street, Opposite Pennsylvania R. R. Depot, Newark, N. J.

**Glorieux, W. L.**—Assayer, Refiner and Sweep Smelter. 13 and 15 Franklin Street, Newark, N. J.

**Hopper & Wilson**—Manufacturers of Fine Jewelry, No. 8 Maple Place, Rear 44 Green St., Newark, N. J.

**Huger & Heitlinger**—Manufacturers to the Jobbing Trade only. Makers of Roman, Stone, Engraved and Enameled Lockets a specialty. Also Sleeve Buttons, Collar Buttons and Studs. 477 Washington Street, Newark, N. J.

**Krippendorf, C. & Schuller, F.**—Machinists and Jewelers' Tool Makers. 19 Greene Street, Newark, N. J. Rolls, Dies, Cutters, and Draw-plates of every Description made and repaired.

**Lelong, L. & Bro.**—Gold and Silver Refiners. Assayers and Sweep Smelters, Southwest corner of Halsey and Marshall Streets, Newark, N. J.

**Milne, Alex.**—Manufacturer of Stem-winding Watch Crowns. 19 Ward Street.

**Regad, E. D.**—Lapidary. Specialty—Sardonyx, Black Onyx and Agates. 14 Oliver St., Newark.

### PROVIDENCE

**Arnold & Webster**—Manufacturers of Solid Gold Engraved Band Rings for the Jobbing Trade. 29 Point Street, Providence, R. I.

**Bradley, R. & Son**—Manufacturers of Solid Gold and Rolled Plate Jewelry. White Stone Goods a Specialty. 227 Eddy Street, Providence, R. I.

**Capron & Co.**—Manufacturers of Jewelry. Engraved Box Bracelets, Bangle Wire Bracelets, Original Lever Collar and Cuff Button. No. 407 Pine Street, Providence, R. I.

**Coombs & Tuttle**—Manufacturers of a large variety of Fine Bracelet and Eye-Glass Chain in Gold Plate and Silver, Spring Rings, Holders, Hooks, Snaps, etc. 35 Point St., Providence, R. I.

**Hamilton, William & Co.**—Manufacturers of Fine Rolled Plated Chains and Patent Band Bracelets. 116 Pine St., Providence, R. I.

**Hough, W. S., Jr., & Co.**—Manufacturers of the Hough, Jr., Rolled Plate Lockets, Charms and Pendants. For sale by all first-class Jobbers or Wholesale Jewelers in the United States and Canadas.

**Hutchison & Huestis**—Makers of Solid Gold Rings. Quality guaranteed. For the Jobbing Trade only. 185 Eddy Street, Providence, R. I.

**Irons, Chas. F.**—Manufacturer of Solid Gold Jewelry. Specialty, Emblems, Pins and Charms, Masonic, Odd Fellows, etc. 102 Friendship St.

**Pitts & Hicks**—Manufacturers of the Excelsior Button and Eclipse Lever Button, also a line of White Stone Gold Goods and a fine line of Lace Pins and Drops in Rolled Plate Goods. 120 Dorrance Street, Providence, R. I.

**Taylor, Geo. H. & Co.**—Watchmakers and Wholesale Dealers in Watches, Clocks, Watch and Clock Material, Tools, Spectacles, Eye Glasses, &c. Particular attention given to trade work. 136 Westminster Street (Room 1), Providence, R. I.

### PAWTUCKET.

**Draper, J. O. & Co.**—Manufacturers of Jewelers' Fig Soap, adapted for Washing Jewelry, Scratch Brushing and Drawing Wire. Pawtucket, R. I.

**Fuller, Geo. H. & Son**—Jewelers' Findings, Gold, Silver, Gold Plated and Fire Gilt. Pin Stems, Joints, Catches, Split Rings, Chain Hooks and Swivels, Ear Wires, Chain Bars, etc. 99 Exchange Street, Pawtucket, R. I.

### CINCINNATI.

**Hellebush, Clemens**—Manufacturer, Importer and Wholesale Dealer in everything required by the Jewelry Trade. 77 W. Fourth St., Cincinnati, O.

**Holland, John**—Manufacturer of Gold Pens, Pencils and Pencil Cases, Gold Toothpicks, etc. Nos. 19 and 21 W. 4th St., Cincinnati, Ohio.

### BALTIMORE.

**Gruebel & Kesmodel**—Manufacturers of Fine Diamond Etruscan, Enameled, Plain and Rhine Stone Jewelry to order. Repairing a specialty. Orders by Mail solicited. 212 & 214 W. Baltimore St., Balto., Md.

### BOSTON.

**Boston Watch Case Co.**, makers of Watch Cases. Especial attention given to Repairing. 1, 3 & 5 Province Court, Boston, Mass.

**Boyce, E. J.**—Manufacturer of Solid Gold Jewelry. Rings a Specialty. 383 Washington St., Boston, Mass.

**Weber, H. & Co.**—Wholesale Jewelers, Importers and Jobbers of Fine Watch Materials, Jewelers' Findings, Tools, etc., Optical Goods and Silk Guards. Agents for Whitcomb, Standard and Stark's Lathes. 424 Washington St., Boston, Mass.

### BUFFALO.

**Oliver, W. W.**—Manufacturer of Hand and Power Rolling Mills for Jewelers and Silversmiths, 39 Clinton Street, Buffalo, N. Y.

### CLEVELAND.

**Chandler, J. M. & Co.**—Manufacturers of the Patent Embossed Bracelet and Jobbers in all kinds of Clocks, Watches, Jewelry, Tools, Materials, etc. 185 Superior St., Cleveland, O.

### LANCASTER.

**Bowman & Musser**—Jobbers in Watches, Clocks, Chains, Fine Tools and Materials. 20 East Chestnut Street, Lancaster, Pa.

### PITTSBURGH.

**Goddard, Hill & Co.**—Wholesale Dealers in American Watches, Jewelry, Silverware, Clocks, Materials, &c., 43 Fifth Avenue, Pittsburgh, Pa.

**Hodge, Slemmons & Co.**—Wholesale Dealers in American and Swiss Watches, Diamonds, Gold and Plated Jewelry, Clock Material, etc. No. 77 Fifth Ave., Pittsburg.

### NEW BEDFORD.

**Nye, W. F.**—Manufacturer of Watch, Clock and Chronometer Oils, New Bedford, Mass.

**Wheeler, G. B.**—Manufacturer of Watch and Chronometer Oils, New Bedford, Mass.

### WORCESTER.

**Washburn & Moyn Manufacturing Co.**—Makers of Fine Watch Mainsprings, Worcester, Mass. 16 Cliff Street, New York. 107 to 109 Lake Street, Chicago, Ill.

### ALBANY.

**Reiss, Chas.**—31 and 33 So. Pearl Street, Albany, N. Y. Importer of Watch Tools and Material; General Supply; Low Prices. Repairing for the Trade.

### CANADA.

**Ellis, P. W. & Co.**, No. 31 King street, East Toronto, Ontario, Manufacturing Jewelers, Watchmakers, importers and Jobbers of Watchmakers, and Jewelers' Tools, Materials, General Supplies and American Jewelry. Correspondence solicited with manufacturers of Novelties or specialties in American Tools and Jewelry.

GEO. W. DUBOIS.

F. N. NAUMAN.

## GEO. W. DUBOIS & CO.,

IMPORTERS OF

## Watches & Optical Goods.

ALL STYLES AND QUALITIES OF

SPECTACLES AND EYE-GLASSES.

## Longines' Watches and Movements,

The Watches in Gold, Silver and Nickel Cases of New and Handsome Patterns. The Movements fit 18 size Waltham Stem Winding Hunting Cases.

36 Maiden Lane, New York.

ORDERS BY MAIL RECEIVE PROMPT ATTENTION.

## BARNES' No. 4 LATHE, For the Heavier Work of Jewelers.

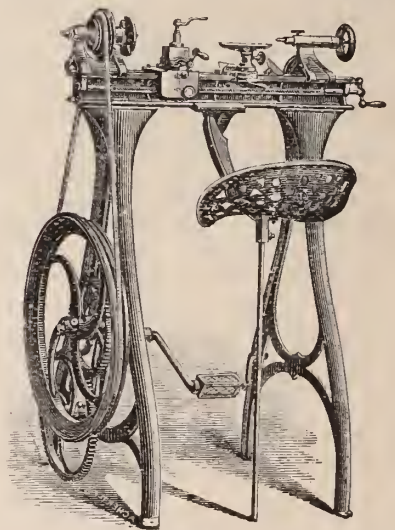

Barnes' Patent Foot and Steam Power Machinery. Complete outfits for Actual Workshop Business. Lathes for wood or metal. Circular Saws, Scroll Saws, Formers, Mortisers, Tenoners, etc., etc. Machines on trial if desired. Descriptive Catalogue and Price List Free.

W. F. & JOHN BARNES,  
2088 Main Street, ROCKFORD, ILL.

## EXCELSIOR'S

Practical Treatise

ON THE

## BALANCE SPRING

Including Making and Fitting Hair Springs, Regulating, etc.

Also containing the Adjustment of Watches and Chronometers for Isochronism, Positions, Heat and Cold and Rate.

PRICE, \$3.50.

D. H. HOPKINSON,  
42 Nassau Street, New York.

ADOPTED AND IN USE BY  
**RANDEL, BAREMORE & BILLINGS,**  
58 Nassau Street, N. Y.

THE TRADE SUPPLIED.  
Descriptive Circulars Furnished  
on Application to  
**George W. Washburn, Patentee,**  
58 Nassau St.,  
NEW YORK.

**SAFETY**  
**EAR FASTENING,**   
*Pat. May 10, '81—Oct. 11, '81.*

**Jointed**  
**EAR WIRE**  
AND  
**BAR BETWEEN CRAMPS**  
OF SETTINGS.   
*Patented March 1, 1881.*

**TELESCOPIC**  
**SAFETY PIN CATCH,**   
*Pat. Sep. 20, '81—Jan. 10, '82.*

**IMPORTANT TO THE TRADE!**

ESTABLISHED 1869.

**CHARLES REISS,**  
Watch and Chronometer Maker.

Repairing for the Trade only. Send for Price List. Receive Jobs all over the U. S. by Mail or Express. Replace Broken Parts of Watches at Low Prices. Fine Repairing Establishment, and none but Experts employed.

**31 and 33 South Pearl Street,**  
**ALBANY, N. Y.**

**OVERMEYER & RÜSBERG,**  
**REMSCHIED (Germany,)**

MANUFACTURERS OF

**Tools for Watchmakers, Jewelers, Mechanics,**  
ETC.

NEW PATENT

**PIN VISES**

**WITH SLIDE, Very Practical and Cheap.**

**REUBEN HAINES,**  
**ANALYTICAL CHEMIST,**  
No. 738 SANSOM ST.,  
PHILADELPHIA.

Laboratory for Assay and Analysis of  
GOLD AND SILVER ORES, LEAD, COPPER,  
ZINC, IRON, STEEL, COAL,  
WATER ANALYSIS.



**BURGESS'**  
Patent Portable Mechanical  
**BLOW-PIPE,**

Supersedes the Forge, Bellows and Mouth Blow-pipe, by saving time, labor, and breath, giving the gentlest flame or hottest blast without exertion.

PRICE, - - \$10.00.  
**J. ELLIOTT SHAW,**  
154 South 4th Street, Philadelphia.

**Washburn & Moen M'fg. Co.,**  
**WORCESTER, MASS.**

Manufacturers of Fine Watch Mainsprings for American, Swiss and English Watches, which, for Toughness, Elasticity and Finish, are Unequaled.

N. Y. Warehouse: **16 Cliff Street.** Chicago Warehouse: **107 to 109 Lake St.**

**P. JANDORF & BRO.,**  
**WATCHES & JEWELRY**

196 BROADWAY,

Bet. John & Fulton Sts., **NEW YORK.**

We Publish No Price Lists.

**Watchmakers' Slide Rests**  
A SPECIALTY.

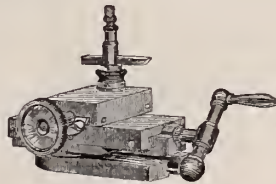

TWO STYLES,  
PRICE,  
**\$10.00 & \$16.00.**

Warranted as good as the best. Sent C. O. D. on approval. Write for Illustrated Circular to the Manufacturer

**R. H. FRAZEE,**  
**TOLEDO, IOWA.**

**EXCELSIOR'S**  
Practical Treatise  
ON THE  
**BALANCE SPRING**

Including Making and Fitting Hair Springs, Regulating, etc.

Also containing the Adjustment of Watches and Chronometers for Isochronism, Positions, Heat and Cold and Rate.

PRICE, \$3.50.

**D. H. HOPKINSON,**  
42 Nassau Street, New York

ESTABLISHED 1873

**CHAS. P. HEROLD**  
MANUFACTURER JEWELER  
**DIAMONDS**  
916 CHESTNUT STREET UP STAIRS  
PHILADELPHIA

**H. WASELL,**  
RUBBER STAMPS,  
BRASS STAMPS,  
Brushes, Inks, &c.  
Stencil Plates,  
**STEEL STAMPS.**  
Burning Brands,  
SEALS & PRESSES,  
No. 7 North William St.  
First house South of East River Bridge, N. Y.  
**FINE STEEL STAMPS A SPECIALTY.**

**C. KNAPP,**  
Manufacturer of  
Superior Band  
and Children's  
Stone & Fancy  
**RINGS**



And Enameled Goods,  
**41 Maiden Lane,**  
**NEW YORK.**

**BUERK'S WATCHMAN'S TIME DETECTOR.**

Safety Lock Attachment Pat. April 25, '82.

Used by all large manufacturing establishments, public buildings, warehouses, etc., to control watchmen. The simplest, strongest, cheapest and most complete of its kind made.

Price, with pouch, 400 paper dials, record book, and 12 different keys with chains for 12 stations.

**COMPLETE, \$50.00.**

**O. E. HAUSBURG,**  
71 NASSAU ST., Room 3,  
P. O. Box 1239, **NEW YORK.**

**GEORGE UIBEL,**

MANUFACTURER OF

Sea Bean & Alligator Teeth

JEWELRY

142 Fulton St., N. Y.



Send for Catalogue and Price List.

**EXCELSIOR'S**  
Practical Treatise  
ON THE  
**BALANCE SPRING,**

Including Making and Fitting Hair Springs, Regulating, etc.

Also containing the Adjustment of Watches and Chronometers for Isochronism, Positions, Heat and Cold and Rate.

PRICE, \$3.50.

**D. H. HOPKINSON,**  
42 Nassau Street, New York.

# Spencer Optical Manuf'g Co.

ARE NOW MAKING MANY

**NEW**

AND

**Desirable Styles**

FOR THE

**Early Spring Trade.**



**Indestructible Celluloid Spectacles,**  
Our Gold Goods are Unsurpassed  
for Beauty, Durability  
and Finish.

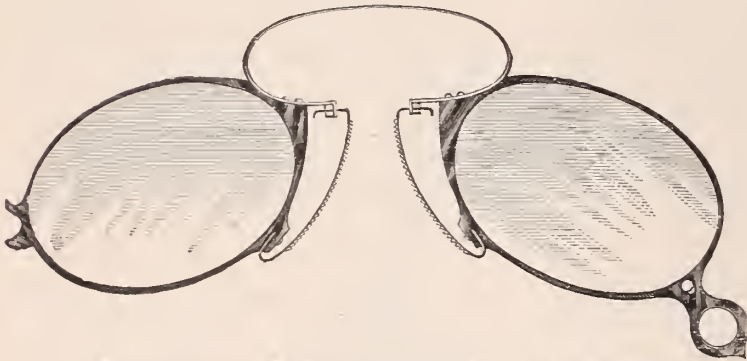

## CELLULOID SPECTACLES.

The very latest improvement, made in Shell and Amber Color; it has substantial advantages over all others, being strong, light and not subject to rust.

THE

## CELLULOID EYE-GLASS

has made its own reputation and is universally popular wherever introduced.

### BEWARE OF IMITATIONS.

We make a **SPECIALTY** in **SPECIAL GOODS** for the **FINE RETAIL TRADE**, which gives customers handling our goods **IMMENSE ADVANTAGE** over all others.

### QUALITY OF GOLD GUARANTEED.

We are importing large Invoices of Opera, Field and Marine Glasses in Staple and Novel Designs.

Catalogue sent on receipt of Business Card.

**Spencer Optical Manufacturing Co.,**  
13 MAIDEN LANE, NEW YORK.

Established 1853.

# L. H. KELLER & CO.

Successors to G. A. HUGUENIN,

IMPORTERS OF

WATCHMAKERS' and JEWELERS'

## TOOLS AND MATERIALS.

GENERAL AGENTS FOR

The Philadelphia Watch Company,

— AND —

American Watch Tool Co.,

MANUFACTURERS OF

## THE WHITCOMB LATHE.

SOLE AGENTS IN THE UNITED STATES FOR THE SALE OF

**LUTZ'S**

## CELEBRATED ROLL HARDENED HAIR SPRINGS, MOEBIUS OIL

For Chronometers, Watches, Clocks, Telegraph Instruments and all other delicate machinery. Made from Pure Refined Neatsfoot Oil, and Warranted to Excel anything in the market as a Lubricator. **SAMPLES GRATIS.**

### OUR OWN GRADUATED

AND JURGENSEN RECOILING MAINSPRINGS, pronounced by all experts Superior to all. Sold in Separate Strengths or Force.

Extra Fine Pinions cut from Solid Steel Wire. Gauged Hole Jewels of First-class Workmanship. A Full Line of Materials, for the PATEK, PHILIPPE & CO. GENEVA WATCHES, and all other Celebrated Makers.

### THE BOLEY LATHES AND TOOLS,

Celebrated for their Practical, Substantial and Workmanlike Construction, Superior Design and Finish.

*Our aim is to furnish nothing but First-class Serviceable Goods, especially manufactured for the Consumer, and not solely for the Market, like the cheap trash advertised in highly illustrated catalogues with which the country is flooded.*

**TREATISE ON MODERN HOROLOGY IN THEORY AND PRACTICE.** By M. CLAUDIUS SAUNIER, Ex-Director of the School of Horology at Macon, France; Knight of the Legion of Honor, etc.; Hon. Sec. to the Paris Society of Horologists. Translated from the French by JULIEN TRIPPLIN, Besançon Watch Manufacturer, and EDWARD RIGG, M. A., Assayer in the Royal Mint, London.

This Work comprises 832 large octavo pages, with 78 wood cuts and 21 colored double-page copper-plate engravings. Bound in half calf, with an appropriate and handsome ornament in gold on front cover.

**Price, \$15.00.**

**THE WATCHMAKER'S HAND BOOK.** By the same author and translators. Intended as a companion to the Treatise. Bound in cloth.

**PRICE, \$4.00.**

**64 Nassau Street,**

NEAR MAIDEN LANE,

**NEW YORK.**

L. H. KELLER,  
EDWARD HUNZIRER,  
F. J. BOESSE.

We do not publish Price Lists.

**SPECIAL NOTICES.**

**Notices under this heading, not to exceed Six Lines, \$1.00 each insertion.**

Advertisers having letters addressed in care of this office, must inclose postage for answers forwarded.

**FOR SALE**—One Wight engraving machine in good condition; price \$16. Address W. T. Sargent, Hentner, N. H.

**A FINE BLISS** transit instrument costing \$125 new, to sell or trade for an American lathe. Address C. B., care Jewelers' Circular.

**A FIRST-CLASS** jeweler and engraver can secure a permanent position by applying to Maier & Delkin, Atlanta, Ga. Must come well recommended.

**WANTED**—First-class watchmaker immediately, one who can do engraving preferred. Wages \$15 per week and steady employment. Address W. & S., care of Jewelers' Circular.

**WANTED**—By a first-class watchmaker a permanent situation; have had 15 years' experience; best of references furnished. Address to A. Y. M. F. C. B., care of Jewelers' Circular.

**SEND FOR** "How to Repair Music Boxes" with illustrated price list of material; price 25 cents. No watchmaker should be without it. Jacot, Juillerat & Co., 37 Maiden Lane, New York.

**FOR SALE**—A first-class jewelry store 20 miles from N. Y. city, is established and a good paying business. Reason death of proprietor. Address Tell A. Beguelin, 71 Nassau street, N. Y.

**READ—ACT**—If you want a good stock low, I mean low, in a good town in Virginia. I mean business. Stock reduced to suit purchaser. Write for particulars. L. B. J., care of Jewelers' Circular.

**WANTED**—A thoroughly competent watchmaker, one who can engrave preferred and competent to wait on customers; must be a first-class workman. Address Virginia, care Jewelers' Circular.

**FOR SALE**—A jewelry store doing a good business in a town of 1,800 inhabitants in northern Illinois. Stock will invoice \$2,700. Address N. Illinois, care C. H. Knights & Co., 125 State street, Chicago, Ill.

**WATCHMAKER'S LATHE FOR SALE**—A splendid nickel plated lathe with a full set of attachments, cost \$400; will sell at a great bargain. Address J. E. Stephens, Waltham, Mass. Box 80, So. Side.

**WANTED**—By a watchmaker a situation either in this city or country. Has had large experience in all branches of the business. 34 years of age, and is also a first-class salesman. Address L. H., care of this office.

**FOR SALE**—Stock and fixtures of a good paying jewelry business in live town in western New York. Good reasons for selling. Apply immediately as the chance is a good one. Address Seller, care Jewelers' Circular.

**WANTED**—Situation as watchmaker; have had 4 years' experience at the bench with a skilled workman; can furnish reference from late employer. Address stating particulars, Willing, care Jewelers' Circular.

**SITUATION WANTED**—A first-class watchmaker desires a permanent situation in the city or within 200 miles of it. 14 years' experience. Best of references. Wages from \$15 to \$20. Address H. Kallenberg, 518 Grand street.

**WANTED**—By a first-class jobber and salesman, a permanent situation; 10 years' experience. French clocks and musical instruments a specialty. Good reference furnished. Address Jobber, care Jewelers' Circular.

**MOSELEY & CO.**, Elgin, Ill., manufacturers of the "Moseley" Lathe, with full line of fixtures and attachments. Designed especially for the watchmaker and repairer. Combining accuracy, durability, convenience and style.

**TRADE LAND FOR JEWELRY**—640 acres of fine unimproved land, also several other tracts, 160 acres each near North Platte, Neb., on the U. P. R. R. Will trade all or any part for jewelry. A. M. Day, Wholesale Jeweler, Lincoln, Neb.

**FOR SALE**—One watchmaker's American lathe, 1 Swiss Universal lathe, 1 Swiss rounding up tool, all in perfect order. Photograph and prices will be sent to parties wanting to buy either tool. Address F., 2,595 Broadway, Cleveland, Ohio.

**WANTED**—By July 1st a good reliable watchmaker and when needed will act as salesman. Must be of sober and steady habits. Engraving and jobbing not required. State wages and reference. Address John H. Fearay, 729 Broad street, Augusta, Ga.

**FOR SALE**—At one-third of their original cost, one wheel cutting engine and rounding up tool combined, with full set of cutters and in first-class order, and one Swiss Universal lathe  $4\frac{1}{2}$  inch head. Address F. C. Ries, 103 Second street, Macon, Ga.

**FOR SALE**—Stock, fixtures, good will and lease of a well established jewelry store on a prominent retail street and opposite one of the best markets. Repairs average from \$25 to \$30 per week, and stock amounts to about \$2,000. A splendid chance for a good watchmaker, and satisfactory reasons for selling given. For particulars address H. L. Lemkuhl, 302 W. Howard street, Baltimore, Md.

**PARTNER WANTED**—A thorough watchmaker (German preferred) with \$600 can enter a good paying watch and jewelry business in Newark, N. J., as partner with privilege to buy same. Address with references Jewelry Store, 48 Market street, Newark, N. J.

**FOR RENT**—Desk and vault room in the Jewelers' Exchange Building, corner State and Washington streets, Chicago. Fire-proof building. Fire and burglar-proof vault. Suitable for manufacturing jewelers or importers office. Logan & Baro, 104 State St., Chicago.

**SITUATION** wanted by a young man nineteen years old who has worked at the bench over three years. Besides other bench work can do some plain and monogram engraving, also wait on customers. Can furnish best of references. Address B., care S. Lewenberg, Alpena, Mich.

**WANTED IMMEDIATELY**—A good workman on watches, jewelry, etc., capable of running a shop. Whole profit of repair business given to right party. Business established and constantly growing. Must give good reference and furnish tools. Address F. Keith, North Brookfield, N. Y.

**GEORGE E. WILKINS**, manufacturer and importer of cutters for watchmakers' use, stem-winding cutters of all the different forms, rounding up cutters of the finest quality, also ratchet cutters. A large stock of second hand and new marine chronometers. No. 21 South Salina street, Syracuse, N. Y.

**WANTED**—Young man who is a good jobber and has had some experience on watches. To a party anxious to finish the trade under 35 years' experience we can offer a good opportunity and permanent position when finished. Address at once with full particulars, Jno. Mitsch & Son, Allegheny, Pa.

**FOR SALE**—Jewelry store, stock and fixtures or fixtures only as may be desired, in a fine improved city of 10,000 inhabitants in western Pennsylvania. Store in a brick building and best location in town. Rent low. Fine plate glass show cases and good fire-proof safes. A splendid opportunity for a practical watchmaker with a capital of \$5,000. Good reasons for selling. Address F. P. Nuse, Titusville, Pa.

**FOR SALE**—An old-established jewelry business which the present owner started 30 years ago. Stock consists of diamonds, wafers, clocks, jewelry, silver and plated ware, etc. to the amount of about \$15,000, all well selected and in good order. Store situated in a city of 60,000 inhabitants. Will sell on easy terms to a responsible purchaser. The strictest investigation is invited. Address A. B. C., care Jewelers' Circular.

**INTERESTING FOR MANUFACTURERS OF CHARMS**—A patent right for sale. Or a capable man of honest and noble character with capital as partner wanted. For a quite new and useful charm which is patented in four countries. Already manufactured and sold in Germany with great success, and of no doubt it will make a great success in the United States. For further particulars, address Hohelsen's Patent Charm, care of Jewelers' Circular.

**TO THE TRADE**—I make a specialty of supplying the Trade with stones for jobbing purposes. Parties having jewelry out of which the stones have been lost, sending their orders by mail or express, will have them promptly attended to. A large stock of cameos, pearls, turquoise, garnets, amethysts, doubiets, foil backs, white and colored imitation stones on hand. All kinds of setting done for the Trade. W. Archibald, 73 Nassau street, New York.

**FOR SALE**—One of the cleanest stocks and best locations in the U. S. for the size of the city. Stock and fixtures invoice about eight thousand. Has paid over seventy-five per cent. net profit each year for the last three years. Store is brick, iron columns, plate glass front and one of the neatest buildings and store fixtures in the state. Will sell store or rent it. Counters are low and cases high and all plate glass. Will sell tools and materials or without. Population thirty-five hundred. Two R. R., five churches, public schools, state agricultural college in flourishing condition, opera house, city fire department and water works, good hotels. Object of selling, simply this and nothing more: We have all the money we need and made every cent except twenty dollars, our original capital, right in this city and in this business in the last five years, and wish to retire from business. City in an agricultural part of the state and growing rapidly. No we do not wish to trade it for cats or dogs or real estate, but those having cash or bankable security and wishing to invest in the jewelry business will do well to investigate. None others need apply. Address E. W. Reed, Fort Collins, Colorado. Reference, Alkin, Lambert & Co., 23 Maiden Lane, N. Y.

**BUYERS' DIRECTORY.****NEW YORK.****Assayers and Sweep Smelters.**

**Wundoehl, H.**—Gold and Silver Refiner, Assayer and Sweep Smelter. 21 John Street, N. Y.

**Badges and Medals.**

**Stockwell & Newman**—19 John Street. Manufacturers of Badges, Medals and Presentation Pieces in Gold and Silver. Also Jewelry and Mounters of Diamonds. Designs supplied.

**Band Rings.**

**Knapp, Charles**, 41 Maiden Lane, N. Y. Specialty: Superior Band Rings, also Ring Shanks & Leads for Seal and Diamond Rings.

**Black Onyx Jewelry.**

**Cox & Sedgwick**—Manufacturers of Black Onyx Jewelry, No. 26 John St. New York.

**Lawson, Samuel**—No. 18 John Street. Manufacturer of Black Onyx Jewelry. Coral repaired for the trade. Goods sent on approval to responsible dealers.

**Woglom & Miller**—Manufacturers of (exclusively) Black Onyx Jewelry, 32 & 34 John St., N. Y.

**Blue Enameled Lockets.**

**Bissinger, Philip & Co.**—Importers of Diamonds Pearls and Precious Stones. Agent for the Bohemian Garnet Goods. Blue Enameled Lockets, 22 John St., N. Y.

**Emrich, I.**—Importer of Blue Enameled Lockets, Ear Drops and all kinds of Enameled Jewelry; also Enamel for Manufacturing purposes. 66 Nassau St., N. Y.

**Hess & Schliesser**—Importers of Diamonds, Fine Jewelry and Novelties in French Goods. Specialties: Gold and Blue Enameled Lockets, Charms and Crosses. 25 Maiden Lane.

**Bohemian Garnet Jewelry.**

**Bissinger, Philip & Co.**—Importers of Diamonds, Pearls and Precious Stones. Sole Agent for the Bohemian Garnet Jewelry. Blue Enameled Lockets. 22 John St.

**Emrich, I.**—Importer of Half Pearls and Bohemian Garnet Jewelry. Designs made to order in our European Factory at moderate prices. 66 Nassau St., N. Y.

**Clock Companies.**

**Ansonia Clock Co.**—Manufacturers of every description of Clocks. 11 to 21 Cliff street, New York.

**Kroeber, F.**—Manufacturer and Dealer in American and French Clocks, No. 14 Cortlandt Street.

**New Haven Clock Co.**—16 and 18 Park Place, N. Y.

**Seth Thomas Clock Co.**—20 Murray Street, N. Y.

**Waterbury Clock Co.**—M. Bailey, Treasurer, Manuf and Jobbers, No. 4 Cortland St., N. Y., and No. 197 State Street, Chicago.

**Welch, E. N., Manufacturing Co.**—Manufacturers of American Clocks. No. 6 Warren St.

**Wm. L. Gilbert Clock Co.**—No. 6 Murray Street, Manufacturers of Clocks. Factories, Winsted, Conn.

**Cameo Cutters, Etc.**

**Peiter, Theodore**—Cameo and Intaglio Engraver. Patentee of the Cameo-Intaglio. No. 3 Maiden Lane, New York.

**Charms & Gold Watch Keys.**

**Rupp & Held**—Manufacturing Jewelers, Charms and Gold Watch Keys, with French and English Ratchets, a specialty. 15 John St., N. Y.

**Crucibles.**

**Berge, J. & H.**—Established 1850. Importers of Sand Crucibles, Covers, Chemical Porcelain, Glassware, and Jewelers' and Assayers' Supplies 95 John Street, N. Y.

**Cutlery.**

**Harrison Bros. & Howson**—Manufacturers of Fine Ivory and Pearl Table and Pocket Cutlery, Carvers in Cases; Nutpicks, Nutcracks and goods suitable for the jewelry trade. 126 Chambers Street. W. C. Burkinshaw, Sole Agent.

**Diamond Brokers.**

**Anderson, Otis**—Diamond Merchant and Broker, always ready to pay cash for bargains in Diamonds and Precious Stones, 4 & 6 John Street, N. Y.

**Bernhardt, Richard**—Diamond Broker and Importer, 65 Nassau Street (Room 6), N. Y. Paris, 20, rue des Petites-Écuries.

**Friend S. & Son**—Brokers and dealers in Diamonds 33 John Street, cor. Nassau St. New York.

**Herbert, R. J.**—Diamond Broker and Dealer, 26 Maiden Lane.

**Diamond Importers.**

**Bernhard, A. & Co.**—Importers of Diamonds and Manufacturers of First-class Diamond Jewelry, Diamond Settings for Manufacturing Jewelers. Catalogue of Designs for the Trade free of charge. No. 2 Maiden Lane, New York.

**Bissinger, Philip & Co.**—Importers of Diamonds, Pearls and Precious Stones. Agent for the Bohemian Garnet Goods. Blue Enameled Locketts. No. 22 John St., N. Y.

**Bruhl, D. & M.**—Established in 1843. 14 Maiden Lane, N. Y.; 111 Broad Street, Providence, R. I.; 14 Rue Bleue, Paris.

**Brunswick, S. & Co.**—Importers of Diamonds. 17 Maiden Lane, New York. Paris, Rue Lafayette. Amsterdam, Damsstraat.

**Citroen, L. B., & Co.**—Diamonds. 21 John St., N. Y. Cutting Works, 57 & 61 Rapenburgerstraat, Amsterdam. House in Paris, 44 Rue Laffitte.

**Faulkenau, Oppenheimer & Co.**—Manufacturers, Diamonds and Diamond Jewelry. 40 Maiden Lane, N. Y.

**Fera, Henry**—Importer of Diamonds, and Manufacturer of Fine Diamond Jewelry. 4 & 6 John Street, New York. Amsterdam, Holland, 23 Loojersgracht.

**Fox, M. & Co.**—Importers of Diamonds, Rubies, Sapphires and Fancy Gems. No. 1 Maiden Lane, New York

**Hedges, Wm. S. & Co.**—Importers of Diamonds No. 170 Broadway, corner Maiden Lane.

**Henle Brothers**—Importers of and Wholesale Dealers in Diamonds only. No. 16 Maiden Lane, N. Y. Paris, 20 Rue Laffitte.

**Kuhn, Doerflinger, & Co.**—Manufacturing Jewelers and Importers of Diamonds, 18 John street New York

**Leberthon, L. M.**—Importer of Diamonds and Manufacturer of Fine Jewelry. 14 John Street, N. Y.

**Neresheimer, E. Aug. & Co.**—Importer of Diamonds. No. 21 Maiden Lane, New York.

**Randel, Bairemore & Billings**—Importers of Diamonds, corner Maiden Lane and Nassau St.

**Saril, S.**—Importer of Diamonds, 182 Broadway, N. Y. Branch of Vve. H. A. Marchand & Frères, 47 Rue Le Peletier, Paris.

**Saunders & Ives.**—Importers of Diamonds and other Precious Stones. No. 26 Maiden Lane.

**Smith, Alfred H. & Co.**—Importers of Diamonds, No. 182 Broadway.

**Tannenbaum, L. & Co.**—Importers of Diamonds and Precious Stones. Steam Lapidary Works. Oriental Stones Cut and Polished a specialty. 65 Nassau St., N. Y.

**Taylor & Brother.**—Importers of Diamonds and Diamond Jewelry. 860 Broadway.

**Wickham, D. H. & Co.**—Importer of Diamonds. No. 31 Holborn Viaduct, London, 24 Maiden Lane, New York.

**Wolf, G. A.**—Importer of Diamonds, Rubies, Sapphires, Pearls, and other Precious Stones, 65 Maiden Lane, New York. 12 Rue de Chateaudun, Paris.

#### Diamond Jewelry.

**Baldwin, Sexton & Peterson**—Importers of Diamonds and Manufacturers of Diamond Jewelry, 692 and 694 Broadway, N. Y.

**Bornemann, Louis.**—Importer of Diamonds and Manufacturer of Rich Diamond Jewelry, 19 John Street, New York.

**Chalumeau, D.**—Diamond Jeweler and Manufacturer of Mountings. Novelties and Artistic Jewelry. No. 3 Maiden Lane, New York.

**Goldsmith, Ingomar & Co.**—Manufacturers of Diamond Mountings and Diamond Jewelry, 61 Nassau Street, New York.

**Goldsmith & Co.**—Manufacturers of Fine Diamond Mountings and Diamond Jewelry. Lace Pins, Ear Rings and Rings a specialty. 49 Maiden Lane, N. Y.

**Hartje, G. & F.**—Manufacturers of Diamond and Fine Jewelry, 39 Union Square, N. Y.

**Haug, John**—Manufacturer of Fine Diamond Mountings, etc. No. 130 Fulton St., N. Y.

**Heller & Bardel.**—Manufacturers of Diamond and Pearl Jewelry, and Dealers in Diamonds, Pearls, &c. 13 John Street.

**Jeanne Brothers.**—Manufacturers of Diamond Mountings & Rich Jewelry. 1 Maiden Lane.

**Lacroix & Verpillier.**—Manufacturers of Fine Gold Jewelry. Diamonds a specialty. 173 Broadway, N. Y.

**Luthy, A. & Co.**—Manufacturers of Fine Diamond Mountings, Lace Pins, Ear Rings, Rings, Knife Edge Bracelets, Hair Ornaments, etc., a Specialty. 35 Ann Street, corner Nassau Street, N. Y.

**Mitchell, Noah**—Manufacturer of Diamond Jewelry and Diamond Mountings. 52 Maiden Lane, New York.

**Nissen, Ludwig & Co.**—Dealers in Diamonds and Diamond Jewelry. No. 51 Nassau Street, New York, near Maiden Lane.

**Rosswog, C. & For.**—Manufacturers of Rich Diamond Goods. Nos. 5 and 7 Maiden Lane, N. Y.

**Scheer, William**—Diamond Jeweler and Manufacturer of Mountings, Novelties in Artistic Jewelry, 859 Broadway, near 17th St., N. Y.

**Stern, Louis**—Manufacturing Jeweler. Diamond Mountings a Specialty. 8 & 10 John St., N. Y.

**Voelker, C. T.**—Manufacturer of 18-k. Diamond Mountings, Diamond Jewelry and Roller Chain Bracelets. 15 Maiden Lane, New York.

**Waterman & Lehmann.**—Manufacturing Jewelers and Dealers in Diamonds. Diamond Work, and Fine fancy Rings a specialty, any piece of single work made to order. 37 Maiden Lane, N. Y.

#### Diamond and Pearl Setter, &c.

**Danziger, H.**—Diamond and Pearl Setter, 116 Nassau Street, (Second Floor,) Room 6, N. Y.

#### Diamond Cutters.

**Levy, Herman.**—Importer, Cutter and Polisher of Diamonds. 105 Fulton Street, New York.

**Mendes, D. De S.**—Diamond Cutter and Polisher, 113 Nassau St., N. Y. Re-cutting, Repairing and Matching a Specialty.

#### Dials, &c.

**Farnsworth, C. E. & Co.**—Successors to Jno. T. Gold, Manufacturers and Jobbers in Fine Watch Dials. 81 Nassau St., N. Y.

**New York Dial Co.**—Manufacturers of Fine Watch Dials. Henry Abbott, Agent, No. 4 Maiden Lane, N. Y.

#### Enameled Clock Dials and Figures.

**Caeser Bros.**—Manufacturers of Enameled Clock Dials, also letters and numbers for signs. 230 and 232 East 25th Street, New York.

#### Enamellers, Etc.

**Nutt, J. D.**—Enameler on Gold, Silver, and Copper. Linen finished Buttons and Studs. Enameling in colors. 32 and 34 John Street, New York.

**Orr, J. C.**—Enameler on Fine Jewelry. Enameled in Colors. Linen Finished Buttons and Studs. Band Bracelets. No. 75 Nassau Street, N. Y.

**Orr, William N.**—Enameler on Fine Jewelry. Masonic Jewels and Badges a specialty. Linen Finished Work. 79 Nassau Street, Room 18, New York.

#### Engravers—Stone Seal, Etc.

**Fackner, Edward**—Carver, Engraver and Chaser on Jewelry and Pencil Cases, lettering, &c., 19 John Street.

**Holland & Gosling**—Stone Seal Engravers. Precious Stones inlaid and encrusted with Diamonds. No. 176 Broadway, New York, (fifth floor per elevator). Cameos cut and repaired.

**Knapp, Chas.** Engraver, Die Sinker & Stamper for Jewelry purposes. Ring Shanks & superior Band rings, 41 Maiden Lane, N. Y.

**Park, Wm.**—The Stone Seal Engraver. Arms, Crests, Monograms, etc., engraved on precious stones. 26 John Street, New York.

**Weston, James F.**—Stone Seal Engraver and incruiter of Precious Stones. Coats of Arms, Masonic, Odd Fellows, and other devices engraved. 32 John Street.

#### Fancy Goods, Clocks, Bronzes, Etc.

**Hinrichs, C. F. A.**—Importer of Fancy Goods, Glassware, China, Clocks, Bronzes, etc. 31 Park Place.

**Le Boutillier & Co.**—Importers of Fancy Goods, Clocks, Bronzes, &c., 3 Union Square.

**Straus, L. & Sons**—Importers of Potteries, Faïences, Bisque Figures, and Rich Fancy Goods especially adapted for the Jewelry Trade. 40, 42 and 44 Warren Street, New York.

**Taylor & Bro.**—Importers of French Clocks, Bronzes, etc. 676 Broadway, N. Y.

**Young, J. M. & Co.**—Importers of Fine Parian, Lava, and Bisque Statuary, Bohemian, German and English Fancy Goods, 37 & 39 Murray St., New York.

#### Gold and Silver Cane Heads.

**Cuppia, L. A.**—Importer of Filigree Jewelry and Manufacturer of Silver and Gold Cane Heads and Novelties in Silver and Gold Jewelry. 19 Union Square, N. Y.

**Simons, Bro. & Co.**—Manufacturers of Gold Headed Canes. 611 and 613 Sansom street, Philadelphia.

**Smith, Rest Fenner & Co.**—No. 701 Broadway, Makers of Fine Gold and Silver Headed Canes.

#### Gold and Silver Plating, Etc.

**Bantle, A.**—Gold, Silver and Electro-Plating, 130 Fulton and 89 Nassau Streets, cor. Fulton Street, (Room 36,) N. Y. Watch Case Polishing.

**Jeantheur, F. & Son.**—Gold and Silver Electro Platers & Fire Gilders, coloring Etruscan and Gold Jewelry a specialty. 125 Fulton St.

**Klees & Magrath**—Gold and Silver Electro-Platers. Coloring Etruscan and Gold Jewelry a Specialty. 89 Nassau Street, New York.

#### Gold Chains, Etc.

**Beck, J. & Son.** Manufacturers of Fine Gold Chains and Chain Bracelets, 10 Liberty Place, near Maiden Lane, N. Y.

**Carter, Sloan & Co.**—Manufacturers of Fine Gold Chain, 15 Maiden Lane, New York.

**Edge, W. C. & Co.**—Manufacturers of the Celebrated Woven Fabric Gold Chain, No. 15 John Street.

**Kaufmann Bros.**—Manufacturers of Gold Chains, and Chain Bracelets, 26 John Street; Factory, 331 and 333 Bowery, N. Y.

**Kohn, Alois & Co.**—Manufacturers of Gold Chains. 9 Maiden Lane, N. Y.

**Saxton, Smith & Co.**—Manufacturers of Fine Gold Chain, No. 14 John Street, N. Y.

**Schlag, Chas.**—(Late Nordt & Schlag), Manufacturer of Gold Chains, Chain Bracelets and Fine Jewelry. 177 Broadway, New York. All kinds of Jobbing promptly attended to.

**Smith, W. & Co.**—Manufacturers of Gold and Silver Chains, Jewelry, etc. No. 25 Maiden Lane, N. Y.

#### Gold Pens, Etc.

**Aikin, Lambert & Co.**—Manufacturers of Choice Gold Pens, Cases, Holders, Toothpicks, etc., 23 Maiden Lane, N. Y.

**Fairchild, Leroy C. & Co.**—No. 10 Maiden Lane, New York. Manufacturers of Gold Pens, Pencils, etc.

**Fairchild, Leroy W.**—Manufacturer of Gold Pens, Pencil Cases, Tooth Picks and Novelties in Charms. No. 18 John St., N. Y.

**Gerow, Joseph U.**—Manufacturer of Pencil and Pen Cases for the Jobbing Trade only. No. 44 State Street, (near South Ferry,) Brooklyn, N. Y.

**Hicks, W. S.**—Established 1848. Manufacturer of Fine Gold Pens, Pencil Cases, Tooth Picks, and Charm Novelties of every description. No. 20 Maiden Lane.

**Johnson, E. S. & Co.**—Manufacturers of Gold Pens, Pen Holders and Pencils. Cor. Maiden Lane and Nassau Street, New York.

**Ray Manufacturing Co.**—Gold Pens Manufactured and Stamped for the Trade. Also Pencil and Pen Cases, Tooth-picks, etc. Office, Sales-rooms and Factories, 94 and 96 Nassau street, 129, 131 and 133 Fulton street.

**Smith, H. M. & Co.**—Manufacturers of Gold Pens and Holders, Tooth Picks, Pencils, etc. Sole Manufacturers of Sprague's Patent Gold Fountain Pen. Importers of Nickel and Silver Watches. 173 Broadway, New York.

#### Gold Rings.

**Barnet Bros.**—Manufacturers of Stone and Seal Rings, 15 John Street, New York. Factory, Newark, N. J.

**Bowden, J. B. & Co.**—Manufacturing Jeweler.—Solid Gold Rings a specialty, 1 Maiden Lane.

**Dattelbaum & Friedman**—Manufacturers of Fine Cameo and Seal Rings, all kinds of Fancy Rings and Diamond Mountings. 10 Maiden Lane.

**Cable, Geo. W.**—Manufacturing Jeweler. Plain and Band Rings a Specialty. No. 104 Fulton Street, N. Y.

**Ely, W. H.**—Manufacturer of Solid Gold Rings of every description. No. 58 Nassau Street.

**Henrich, R.**—No. 35 Maiden Lane, Manufacturer of Gold Rings; also Patentee and Manufacturer of the Celebrated Self-Sizing Ring.

**Hutchison & Huestis**—Makers of Solid Gold Rings. Quality guaranteed. For the Jobbing Trade only. 196 Broadway, N. Y.

**Kroll, H.**—Manufacturing Jeweler. 78 Nassau Street, New York. Specialty: Solid Gold Stone Rings. All kinds of Fine Jewelry made to order, also Repairing for the Trade.

**Ostby & Barton**—Manufacturers of Plain and Engraved Solid Gold Band Rings. Office, 176 Broadway, N. Y. Factory, 80 Clifford Street, Providence, R. I.

**Peckham, Wm. H.**—Manufacturers of Solid Gold Seamless Rings, and Fancy Embossed Rings, Patent Spectacles, Jewelry, etc. No. 4 Liberty Place N. Y.

**Radler, K.**—Manufacturing Jeweler. Gold Rings and Locketts a specialty. No. 39 Maiden Lane, New York.

**Sauter, L.**—No. 1 Maiden Lane, New York, Manufacturer of Stone Rings of every description, as Diamond, Cameo, Onyx Turquoise, etc., Scarf Pins, Scarf Rings, Studs and Buttons.

**Shafer & Douglass.**—Manufacturers of all kinds of Seal, Stone, Turquoise, and fancy rings. No. 7 Maiden Lane, N. Y.

**Thuerner & Church**—Manufacturers of Fine Gold Rings. No. 9 Maiden Lane, N. Y.

#### Hair Jewelry.

**Moutoux, Wm. E. & Co.**—Manufacturers of Fine Hair Mountings in Gold. Grand catalogues for the trade. 81 Nassau St., Rooms 1 and 2. Finest work and lowest prices

**Sauter, L.**—Manufacturer of Fine Gold and Hair Jewelry and Device Work. Pattern Book sent on application. No. 1 Maiden Lane, N. Y.

**Schwencke O.**—Manufacturer of Fine Hair Jewelry Orders from the country promptly attended to. No. 43 Maiden Lane.

#### Jewelry Cases, Fancy Boxes, Etc.

**American Morocco Case Co.**—7 and 9 Bond St., N. Y., make a specialty of Rich Jewelry and Silverware Cases for the fine Retail Trade. Also Improved Trays for Watches, Rings, etc.

**Bleyle & Fels**—Manufacturers of Jewelry and Silverware Boxes, Jewelers' Traveling Cases, etc. Trays for Show Cases and Trunks, Ladies' and Gent's Jewel, &c., &c., 80 Nassau street, N. Y.

**Braun, Chr. E.**—Manufacturer of Fine Jewelry Boxes and Trays for Show Cases and Trunks. No. 62 Chatham Street, New York. Trays for Show Cases and Trunks a Specialty.

**Bricka, C. A. & Co.**—Manufacturers of Morocco Cases for Cutlery, Silverware, Jewelry, etc. Sample Cards and Rolls. Cases in Rosewood, Black Walnut, etc. 52 Nassau Street, New York.

**Dennison Mfg Co.**—Manufacturers of Morocco, Plush and Velvet Jewelry and Silverware cases. New York, Boston, Philadelphia, Chicago, Cincinnati and St. Louis.

**Ettlinger, L. & Sons.**—Manufacturers of Fine Cases for Jewelry, Watches and Silverware. Trays for Travelers and Show Cases. Cases to Order a Specialty. No. 80 Nassau St., N. Y.

**Haensler, Chas. C.**—Manufacturer of Fine Morocco Cases for Jewelry and Silverware. Toilet Boxes, etc. Trays for Show Cases and Windows. 14 John Street, New York.

**Hebbard & Brother**—Manufacturers of Jewelry and Silver Ware Cases, and Fancy Wood Chests for Tea Sets and Flat Ware, 2 Bond Street, near Broadway, New York.

**Kohn, Solomon & Co.**—Manufacturers of Fine Morocco Cases for Jewelry, Watches, etc. 43 Maiden Lane, New York.

**Lauten, Edw. A. & Co.**—No. 4 Great Jones St., Manufacturers of Fine Velvet, Brocade, Plush and Morocco Boxes, Patent Ring, Ear Ring and Gent's Scarf Pin Trays, Patent Watch and Bracelet Blocks, Window Decorations, etc.

**Metropolitan Fancy Box and Leather Goods Manufacturer**—Makers of Plush, Velvet, Satin and Leather Cases for Watches, Jewelry, Silverware, etc. 75 and 77 Nassau Street, N. Y.

**New York Morocco Case Co.**—Cases for Jewelry, Watches, Silverware. Boxes and Trays for Jewelers' Travelers. Show Cases and Window Fittings. No. 69 Nassau Street, New York.

**Sauer & Schroeter**—Successors to Loehr & Koerner, Manufacturers of Morocco, Velvet, Satin, Jewelry, Watches and Silverware Cases, Jewel, Work Boxes, etc., Fancy Trays and Store Fittings to order. 96 Liberty St.

**Schwarz, N.**—Manufacturer of fine Cases for Jewelry and Silverware, 866 Broadway, near 17th street, N. Y.

**Welch & Miller**—169 Broadway. Manufacturers of fine Morocco, Velvet, Russia, Brocade and Plush Jewelry Cases. Trays of every description; Jeweler's Cotton and Twine.

**Wiggers & Froelick**—No. 60 Nassau street—Manufacturers of Cases for Jewelry, &c., of every description. Trays for Show-cases, Stands for Show-windows, etc.

#### Jewelers' Findings.

**Dennison Mfg Co.**—Paper Jewelry Boxes, cards, tags, pink and white cotton, etc. etc. New York, Boston, Chicago, Cincinnati, Philadelphia, St. Louis.

**Ettlinger, L. & Sons.**—Manufacturers of Jewelers' Paper Boxes and Findings. Morocco Paper, Satin or Plush Lined Wooden Corner Stops Jewelry and Silverware Boxes. 80 Nassau Street, New York.

**Valer, S. & Co.**—Manufacturers and Dealers in Jewelers' Boxes, Tags, Cards, Paper and Findings. Trays a specialty. Fancy Ornaments for Show Windows. 66 Nassau street, New York.

#### Jewelry Manufacturers.

**Aikin, Lambert & Co.**—Manufacturers General stock of Reliable Jewelry, 23 Maiden Lane.

**Alling, Isaac A. & Co.**—Manufacturers of Fine Gold Jewelry. Specialties: Wire Bracelets, Bangles, American Lever Sleeve Buttons. Bryant Building, Nassau and Liberty Streets, N. Y. Factory, Newark, N. J.

**Baldwin, Sexton & Perterson**—Manufacturers of Rich Jewelry, 692 and 694 Broadway, N. Y.

**Ball, W. H.**—Manufacturer of Gold Jewelry. Bracelets and Bangles of all kinds a specialty. 9 John Street, N. Y.

**Barthman, Straat & Co.**—Manufacturers of Fine Jewelry. Roman Goods, Rings, Diamonds. No. 43 Maiden Lane.

**Bissinger, Philip & Co.**—Importers of Diamonds, Pearls and Precious Stones. Sole Agents for the Bohemian Garnet Jewelry, Blue Enameled Lockets. 22 John St., N. Y.

**Brown, Thos. G. & Sons**—Manfr's of Rich Jewelry Necklaces, Locketts, Bracelets, Sleeve Buttons, etc., 860 Broadway, N. Y.

**Bryant & Bentley**—Manufacturing Jewelers. Rings a specialty. 12 Maiden Lane

**Carter, Sloan & Co.**—Manufacturing Jewelers, 15 Maiden Lane, New York.

**Champenois & Co.**—No. 5 Maiden Lane, manufacturers of Engraved and Enameled Gold goods, in Sets, Ear Knobs, Bracelets, Studs, Lace and Shawl Pins, Jet cluster and Onyx goods, also "Best Lever" Sleeve Buttons.

**Chatellier, Joseph F.**—Manufacturing Jeweler, No. 694 Broadway, N. Y.

**Churchill, Lewis & Co.**—Manufacturers of Fine Jewelry. 692 Broadway, cor. Fourth St., N. Y.

**Cook, George W.**—Manufacturer of Fine Jewelry and Locketts, 191 Broadway (over Mercantile Bank,) N. Y.

**Cottle S. Co.**—Manufacturers of Fine Jewelry. 860 Broadway, N. Y.

**Cox & Sedgwick**—Manufacturers of fine Onyx and Colored Jewelry. 26 John St., New York

**Day & Clark**—Manufacturers of Fine Jewelry, Lace Pins, Ear Rings, Studs, Locketts, &c., 10 Maiden Lane, New York.

**Geoffroy, Arthur R. & Co.**—Manufacturing Jewelers. Novelties in Diamond Goods. No. 23 Maiden Lane, N. Y.

**Greene Wm. C. & Co.**—Goldsmiths; Manufacturers of Rich Sets in Taper Wire Coral. Office, 192 Broadway.

**Griffith, H.**—Manufacturing Jeweler. Gold and Plated Jewelry. Scarf Pins a specialty. Nutry Alley, near Concord St., Brooklyn, N. Y.

**Groeschel & Rosman**—Manufacturers of Fine Jewelry. No. 27 John Street, N. Y.

**Hartmann, P.**—Manufacturer & Importer of Fine Gold, Diamond, and Filigree Silver Jewelry, No. 36 Maiden Lane. P. O. Box 2,454.

**Hedges, A. J. & Co.**—Manufacturing Jewelers, 6 Maiden Lane.

**Henderson & Winter**—Jewelers, No. 15 Maiden Lane, New York. Specialties—Stone, Cameo, Onyx, Amethyst, Topaz, Pearl and Turquoise Rings.

**Hunt & Owen.**—Manufacturing Jewelers. Office 3 Maiden Lane.

**Jandorf, P. & Bro.**—Manufacturing and Wholesale Jewelers—all grades. Prompt Attention to Orders. We issue no catalogue. 196 Broadway, N. Y.

**Kipper, Vogel & Co.**—Manufacturing Jewelers, 17 Maiden Lane, New York.

**Krementsz & Co.**—Manufacturing Jewelers, No. 182 Broadway, N. Y.

**Kuhn, Doerfinger & Co.**—Manufacturers of Enamelled and Roman Band Bracelets, also Fine Locketts Pendants and Lace Pins. 18 John street.

**Miller Bros.**—Manufacturers of Fine Jewelry, Locketts, Sleeve Buttons, Studs, &c., 7 Maiden Lane, N. Y.

**Moore & Horton.**—11 Maiden Lane, Manufacturing Jewelers, Rings, Studs, Collars and Sleeve Buttons, Pins, Ear-rings, &c.

**Muhr's, H., Sons.**—Manufacturing Jewelers. Solid Gold and Filled Rings a specialty. Also Manufacturers of the celebrated Crown Filled Watch Case. 16 Maiden Lane, N. Y.

**Mulford & Bonnet**—No. 21 Maiden Lane, New York.

**Owen, G. & S. & Co.**—Manufacturing Jewelers. Office, No. 3 Maiden Lane.

**Richardson, Enos & Co.**—Manufacturers of Fine Gold Jewelry, Gold Chains, Locketts, Crosses and Necklaces. Colored and Etruscan Work. No. 23 Maiden Lane, New York.

**Richardson, J. W. & Co.**—Manufacturers of Jewelry. Masonic and other Emblems. 196 Broadway, N. Y. Manufactory, Providence, R. I.

**Riley, J. A. & Co.**—Manufacturing Jewelers. Etruscan Gold and Roman Bracelets, Lace Pins, Ear Rings, Scarf Pins, Brooch Pins, etc. No. 860 Broadway, N. Y.

**Ripley, Howland & Co.**—Manufacturers of Fine Jewelry and Platinum Tipped Diamond Settings. No. 17 Maiden Lane, N. Y.

**Sauter, L.**—Manufacturer of Fine Jewelry, Solid Stone Rings and Studs a specialty. Jobbing for the trade. 1 Maiden Lane, New York.

**Schwencke, Wm.**—Manufacturing and Jobbing Jeweler. Repairing a specialty. Orders promptly attended to. No. 43 Maiden Lane, N. Y.

**Sexton & Cole**—Manufacturing Jewelers, Colored Gold and Onyx Goods a specialty. No. 30 Maiden Lane.

**Sheafer, W. H. & Co.**—Manufacturing Jewelers, Specialty Bangles and Bræclets, 15 John St., N. Y.

**Stites' Sons, E.**—Manufacturers of Fine Jewelry. No. 14 John Street, N. Y.

**Street, Geo. O. & Sons.**—Established 1837. Makers of Fine Jewelry, strictly first-class goods of our own make. No. 15 John Street, New York.

**Thoma, Ernest**—Manufacturer of Fine Jewelry, Sleeve Buttons, Rings, Ear-rings, &c. No. 173 Broadway, N. Y. Factory, Hackensack, N. I.

**Ward, Thos. M.**—Manufacturer of Fine Jewelry, Diamond Mountings a specialty. No. 25 John Street, N. Y.

**Wienhold, J.**—Manufacturer of Fine Jewelry. Diamond Mountings a Specialty. 24 John St.

**Woglom & Miller**—Manufacturers of Black Onyx Goods exclusively. 32 & 34 John Street, N. Y.

#### Jewelry—Rolled Plate.

**Blackinton, W. & S.**—Manufacturers of the W. & S. B. Rolled Plated Chains. No. 11 Maiden Lane.

**Frick, John & Co.**—Fine Rolled Plate Jewelry of all kinds. Repairing of every description. 21 and 23 Maiden Lane, N. Y.

**Mauran, J. T.**—Manufacturer of Fine Rolled Plate Jewelry, No. 15 Maiden Lane, N. Y.

**Richards, E. Ira & Co.**—Manufacturers of Fine Rolled Plate Jewelry, No. 200 Broadway, N. Y.

**Jewelers' Tools, etc.**

- Fisher, James J.**—Dealer in Watchmakers' and Jewelers' Materials, Files, Tools, Silk Guards Spectacles, etc. 697 Broadway, N. Y.
- Friedenthal, A. & Co.**—Importers and jobbers of Watchmakers' and Jewelers' Tools, Materials, etc. 43 Maiden Lane, N. Y.
- Friedlander, R. & L.**—Importers of Watchmakers' Tools and Materials. 65 & 67 Nassau Street. Branch Office, 264 Bowery.
- Kurtz, F. P.**—Manufacturer of Jewelers Machinery, Tools, Rolling Mills, Presses, Polishing Lathes, &c. 97 Cliff St., N. Y.
- Levy, Dreyfus & Co.**—Importers and Jobbers of Watchmakers' and Jewelers' tools and materials of every description. 11 Maiden Lane, N. Y.
- Montgomery & Co.**—Importers of and Dealers in Manufacturing Jewelers' Tools and Materials of every description, 105 Fulton street, New York.
- Reichhelm, E. P. & Co.**—Importers of Jewelers' Tools, Files, etc. Manufacturers of Brushes and Buffing wheels; also Patent Gas Furnaces for Melting, Plating, Enamelling, Annealing, etc. 80 Nassau St., N. Y.

**Lapidaries.**

- Fox, M. & Co.**—Practical Lapidaries, No. 1 Maiden Lane, New York.
- Graham & Co.**—Practical Lapidaries, Cutters and Polishers of all kinds of Precious Stones. Miners' Relics Cut, Polished and Mounted. Miniature, Locket and Clock Glasses. 80 Nassau St., N. Y.
- Kordmann & Michel.**—Lapidaries. Dealers in Precious Stones. Cutting and Polishing Rubies, Sapphires and other Gems a specialty. Drilling done promptly. 59 Nassau St., N. Y.
- Korn, Ph.**—Lapidary. Importer of Precious and Imitation Stones, No. 63 Nassau street, between Maiden Lane and John street, New York.

**Masonic Jewelry.**

- Luther, John F.**—79 Nassau Street. Manufacturer of Fine Presentation Jewels for all Societies. Knights Templars, Crosses, Badges, &c.
- Wilkinson, C. B.**—Manufacturing Jeweler, 8 John St., N. Y. Medals, Badges and Masonic Jewelry, a specialty. Designs furnished free upon application.

**Optical Goods.**

- Friedlander, R. & L.**—65 and 67 Nassau Street. Dealers in Optical Goods.

**Opticians.**

- Burbank Man'g Co.**—Manufacturers of Spectacles and Eye Glasses of all descriptions, in gold, silver, etc., 14 Maiden Lane, N. Y.
- DuBois, Geo. W. & Co.**—Importers of Watches and Optical Goods. 36 Maiden Lane, N. Y.
- Levy, Dreyfus & Co.**—Importers of Spectacles and Eye Glasses and Optical Instruments of every description, No. 11 Maiden Lane, N. Y.
- Lorsch, Albert**—Manufacturer of the Patent Accommodating Spectacles and Eye Glasses in Gold, Silver and Steel, and other Optical Goods, 37 Maiden Lane, N. Y.
- Spencer Optical Manufacturing Co.**—Gold, Silver, Steel, Nickel and Plated Spectacles; Gold, Celluloid, Steel, Nickel and Rubber Eye Glass and Opera Glasses. 13 Maiden Lane, N. Y.
- Todd, James W.**—No. 20 Maiden Lane, N. Y. Wholesale Dealer in Optical Goods.

**Paper Boxes.**

- Waterbury Paper and Box Co.**, 27 to 35 Canal St., Waterbury, Conn., Manufacture Jewelers' and Silversmiths' Fine Paper Boxes. Quality guaranteed to be equal to the best made.

**Precious Stones, &c.**

- Bishop, Victor & Co.**—33 Maiden Lane, Importers of Precious Stones, Cameos, &c. Also Manufacturers of Coral Jewelry.

**Bissinger, Philip & Co.**—Importer of Diamonds, Pearls and Precious Stones. Agent for the Bohemian Garnet Goods. Blue Enamelled Lockets. No. 22 John St., N. Y.

**Breidenbach, R. A.**—Importer of Black Onyx, Diamonds, Pearls, Turquoise, Cameos, Sardonyx, Amethysts, Garnets, Topaz, Opals, Rubies, Sapphires, Hematite Balls, Foil Brilliants, Cat's-Eyes, Tiger Eyes, Doublets, Cabinet Specimens, etc. 85 Nassau Street, New York.

**Daue, Wm. & Co.**—Importer of Precious and Imitation Stones. No. 202 Broadway New York.

**Fox, M. & Co.**—Importers of Diamonds and other Precious Stones, No. 1 Maiden Lane, N. Y.

**Gruet, Jules.**—Importer of all Grades of Real and Imitation Stones. 14 John St., N. Y.

**Hahn & Co.**—Importers of Precious Stones. Cameos, Onyx, Pearls, Intaglios, Amethysts, Garnets, etc. 64 Nassau Street, New York.

**Kahn, L. & M. & Co.**—Importers of precious and imitation stones. 10 Maiden Lane, N. Y.

**Kipling, E. E.**—Importer of Precious and Imitation Stones. Manufacturer of the Patent Foil Solid Metal Back Rhine Stone Brilliant. No. 6 Maiden Lane, N. Y.

**Kipling, R. A.**—Precious and Imitation Stones, No. 24 Maiden Lane, N. Y. Manufacturer Cameos, Agates, Onyx, Etc., Oberstein, Germany. Commission Merchant, 49 Rue De L'Echiquier, Paris.

**Lorsch, Albert**—Importer of Precious Stones, 37 Maiden Lane, N. Y.

**Stirn, Max & Bro.**—Importers of Black Onyx, Cameos, Turquoise, Half Pearls, Sardonyx, Amethysts, Topaz, Garnets, Opals, Rubies, Sapphires, Cat's-Eyes, and all other imitation stones, 3 Maiden Lane, New York.

**Safes.**

**Butler, W. H.**—Fire and Burglar Proof Safes, 291 Broadway, N. Y.

**Silverware.**

- Gorham Manufacturing Co.**—Union Square.
- Knowles, J. E. & S. M.**—Manufacturers of Sterling Silverware, 20 Maiden Lane, N. Y. Factory, Providence, R. I.
- Shiebler, Geo. W.**—Manufacturer of Sterling Silverware. No. 8 Liberty Place, near Maiden Lane, N. Y.
- Whiting Manufacturing Co.**—Makers of Sterling Silver Ware. Broadway cor, 4th Street, N. Y.
- Wood & Hughes.**—Manufacturers of Fine Silverware. 16 John Street, N. Y.

**Silver Filigree Jewelry.**

- Cuppia, L. A.**—Manufacturer of Solid Silver Novelties, and Importer of Silver Filigree, 19 Union Square.
- Francesconi, Guido**—Importer of Silver Filigree Jewelry, 196 Broadway, New York.
- Hartmann, P.**—Manufacturer of Silver Filigree Jewelry. 36 Maiden Lane, N. Y.

**Silver Plated Ware.**

- Manhattan Silver Plate Co.**—Manufacturers of Silver Plated Ware. Showrooms, 23 John St. Factory, 301 to 305 East 22d St., cor. 2d Ave. Address all communications to Factory.
- Middletown Plate Co.**—Manufacturers of Superior Electro-Plate. Factories, Middletown, Conn., salesroom, 13 John Street.
- Rogers, Smith & Co.**—Manufacturers of Fine Electro Plated Ware. No. 46 E. 14th St., N. Y.
- Simpson, Hall, Miller & Co.**—Manufacturers of fine Silver-Plated Ware. No. 36 E. 14th Street.
- Schade, Henry.**—Manufacturer of White Metal and Plated Ware. Nos. 56 & 58 Ainslie Street, Brooklyn, E. D., N. Y. Price list and catalogue furnished on application.
- The Derby Silver Co.**—Manufacturers of Finest Quadruple Silver Plated Ware, Birmingham, Conn. New York office, 25 Maiden Lane.
- Webster, E. G. & Bro.**—Manufacturers of Fine Silver-Plated Ware. Office and warerooms, 14 Maiden Lane, N. Y.

**Show Cases, Etc.**

**Smith, B. & W. B.**—Manufacturers of Patent Improved Dust Proof Show Cases, with Perpendicular Sliding Doors, No. 220 W. 29th St., N. Y.

**Spectacle Case Manufacturers.**

- Bertine, P. D.**—Manufacturer of Spectacle and Eye-Glass Cases. 139 William Street, near Fulton St., New York.
- Koenen, A. & Bro.**—Manufacturers of Leather Spectacle and Eye-Glass Cases for the Jobbing Trade only. 81 Nassau St., N. Y.

**Stem Winding Attachments.**

**Abbott, Henry** Maker of Stem Winding Attachments, No. 4 Maiden Lane, N. Y.

**Swivels and Spring Rings.**

**Schwartz, V. & Co.**—Manufacturers of Gold Swivel and Chain Trimmings. 33 Barclay Street, New York.

**Thermometers, Etc.**

**Tagliabue, Giuseppe.**—manufacturer of Thermometers, Barometers and Hydrometers. Patentee and sole manufacturer of the U. S. Standard Hydrometer. 302 Pearl Street, near Beekman.

**Thimble Manufacturers.**

- Burbank Manuf'g Co.**—Manufacturers of Gold and Silver Thimbles, 14 Maiden Lane, N. Y.
- Ketcham & McDougall.**—Improved Gold and Silver Thimbles, Bryant Building, N. Y.
- Simons Bro. & Co.**—Manufacturers of Gold and Silver Thimbles, 611 and 613 Sansom Street, Philadelphia.
- Woglom & Miller.**—Sole Agents for the "Prime" Thimbles in Gold and Silver, manufactured by Ezra C. Prime. 34 John Street, N. Y.

**Trunks.**

**Crouch & Fitzgerald**—Manufacturers of Trunks and Articles for Travelers' use. 1 Cortlandt St., 556 Broadway, and 723 Sixth Ave., N. Y.

**Watch Companies.**

- American Watch Co.**—Robbins & Appleton, No. 5 Bond Street, N. Y.
- Illinois Watch Co.**—Springfield, Illinois. 21 Maiden Lane, N. Y. and 71 Washington Street, Chicago, Ills.
- The E. Howard Watch and Clock Co.**—Cor. Maiden Lane and Nassau Street, N. Y.
- Waterbury Watch Co.**—Manufacturers of the Waterbury Watch. Factory, Waterbury. Office, 52 Maiden Lane, N. Y.

**Watch and Chronometer Jeweler.**

- Queen, James.**—Watch and Chronometer Jeweler and Pallet Maker, 78 Nassau Street, room 8. Pivots inserted in Pinions, Balance, Staffs, etc.
- Robert, Henry L.**—Practical Chronometer and Watch Jeweler and Adjuster. 71 Nassau Street. Pallet and Hole Jewels for Chronometer Watches done in the best manner.
- Wennstrom, John.**—Watch, Chronometer and Clock Jeweling, Jewel Gauges, Ruby and Sapphire Draw Plates; Diamond Charged Polishing Stones for Jewel Settings; Pivots inserted in Pinions. 2 Dutch Street, N. Y.

**Watch Importers, Etc.**

- Abry, Chas. Leo**—Importer and Manufacturer of Swiss Watches of all grades. 63 Nassau Street.
- Aikin, Lambert & Co.**—Importers of Watches. Sole Agents for Paul Breton & Chas. Latour, Geneva. A general line of reliable Swiss Watches, Watch Cases, etc. 23 Maiden Lane, N. Y.
- Bartens & Rice**—20 John Street, Importers of Watches and sole agents in the United States for the celebrated Nicole, Nielsen & Co. Watches.
- Cross & Beguelin.**—Importers of Watches, Watch Tools and Materials, dealers in American Watches, No. 21 Maiden Lane, N. Y.
- Droz, Henry E.**—Importer of Watches, and Watch Case Manufacturer. Agent for the "E. Perreux" Watch, and jobber in American Watches No. 92 Fulton Street, N. Y.
- Freund Max & Co.**—Importers of Watches, Jewelry and Precious Stones, 8 Maiden Lane, N. Y.



**Gagnebin, Chas.**—Importer of all kinds of Swiss, and Dealer in American Watches. 4 Maiden Lane, N. Y. Agent for Ulysse Breting's Fine Chronometers, Chronographs, Anchors, &c.

**Gallet, Julien.**—Importer of Watches. No. 1 Maiden Lane.

**Ginnel, Henry.**—Importer of Watches, Tools and Materials, 31 Maiden Lane, N. Y. P.O. Box 2967

**Hyde's Sons, John E.**—Wholesale Commission Agents, only for Jules Jurgensen, of Copenhagen; Jules Monard, of Geneva; and for other makers of all qualities of Watches, 22 Maiden Lane.

**Keller, L. H. & Co.**—Successors to G. A. Huguenin, Importers of Fine Watch and French Clock Materials, No. 64 Nassau Street, N. Y.

**Mathey Bros. & Mathez.**—Importers of Fine Watches and Sole Agents for the **H. L. Matile's** Watches. No. 16 Maiden Lane.

**Robert, J. Eugene.**—No. 30 Maiden Lane, New York. Agent for Louis Audemar's celebrated watches.

**Schumann, Chas. W.**—No. 24 John Street, New York. Importer of Fine Diamonds, Watches, etc. Sole Agent in the U. S. for the celebrated "Lange" Dresden Watch.

**Schwob, Adolphe.**—Manufacturer and Importer of Watches, 11 Maiden Lane, N. Y.

**Strasburger, Louis & Co.**—Importers and Makers of Watches of every description, 15 Maiden Lane.

#### Watch Cases.

**Dueber Watch Case Mfg Co.**—Manufacturers of Gold and Silver Watch Cases. Bryant Building, N. Y. Factory, Newport, Ky.

**Fahys, Joseph.**—Manufacturer of Watch Cases and Dealer in American Movements, 38 Maiden Lane.

**Glatz, Chas.**—Manufacturer of Silver Watch Cases. Bryant Building, cor. Nassau and Liberty Sts.

**Keller & Untermeyer.**—Manufacturers of Watch Cases with Raised Gold Ornaments. 9 Maiden Lane, N. Y.

**Ladd Watch Case Co.**—Manufacturers of the Ladd Patent Stiffened Gold Watch Cases, etc., 11 Maiden Lane, N. Y. Factory, 58 Eddy Street, Providence, R. I.

**Martins & Tissot.**—Manufacturers of Gold Watch Cases. No. 15 Maiden Lane, N. Y.

**The Brooklyn Watch Case Co.**—Manufacturers of the celebrated Eagle Case. 40 Maiden Lane.

**Willemin Watch Case Co.**—Makers of Gold Watch Cases. Raised Gold Ornamentation and Jurgensen style of Engine Turning. 109 Sands Street, Brooklyn, N. Y. 16 Maiden Lane, N. Y.

#### Watch and Chronometer Repairers.

**Cerf, B.**—Practical Watchmaker and Repairer, No. 10 John Street, N. Y. Repairing and adjusting of Fine Watches done for the trade. All kinds of escape and stem-winding wheels cut to order.

**Goepf, Frederick A.**—Practical Watchmaker. Repairing of every description for the Trade. 25 Maiden Lane, N. Y. In office of H. Garland, Engraver.

**Heinrich, H. H. & Co.**—Sole Manufacturers of H. H. Heinrich's Patent Auxiliary Balance, and Adjusters and Repairers of Fine Watches and Chronometers. 12 John Street, N. Y.

**La Croix, J. H.**—(Late with Benedict's Time,) Watch and Clock Maker, 21 John Street, N. Y. Clocks of every description Repaired for the Trade.

**Lesperance, Theo.**—Watchmaker and Wheel Cutter. No. 1 Maiden Lane, New York. With Julien Gallet.

#### Watch Case Repairers.

**Feinier, Joseph A.**—Watch Case Maker and General Repairer. Specialty in fine Gold and Silver Cases. Jobbing promptly attended to. Nos. 4 and 6 John St., N. Y.

**Perret & Jardon.**—Watch Case and Spring Repairers. No. 80 Nassau St. (top floor), N. Y. Cases and Springs of all kinds neatly repaired.

**Tarbox, Hiram.**—Watch Case Repairing, Springing, Polishing and Engine Turning. 1874 North Fourth Avenue, bet. 176th and 177th Sts., N. Y. Express Packages should be sent to 92 Fulton Street.

#### Watch Glasses, Shades, Etc.

**Brown, Edwin H.**—No. 85 Nassau Street, Imported and Own Manufacture Watch Glasses, Flat, Flat Concave, Concave, Convex and fine Genevas. Fine fitting solicited.

#### Watches, Diamonds and Jewelry.

**Alford, C. G. & Co.**—Manufacturers. General line fine and Reliable Goods. Specialties in Onyx Goods and Chain. 200 Broadway, New York.

**Cohn, J. J.**—Importer and Manufacturer of Whitby Jet, Rubber and Pearl goods. Gold and Rolled-plate Jewelry, etc. 12 Maiden Lane, New York.

**Durfey & Reynolds.**—Successors to Durfey & Shiebler, Watches, Diamonds, Jewelry. No. 9 John Street, (up-stairs) New York.

**Friedman, Saml.**—Wholesale Dealer in Watches and Jewelry, 42 Maiden Lane, N. Y.

**Goddard, John M.**—Manufacturing Jeweler, Seal Rings and Fine Lockets a specialty, No. 3 Maiden Lane, N. Y.

**Greason J. R. & Co.**—Successors to Arthur, Rumrill & Co., 182 Broadway. Manufacturers of Fine Jewelry and Gold Chains, also Diamond Mountings.

**Haskell, H. C.**—Manufacturing Jeweler. Seal Rings a specialty. Special attention to Jobbing of every description. 12 John Street.

**Herzog, Louis & Co.**—Importers of Watches, Dealers in Diamonds and Jewelry, 52 Maiden Lane, N. Y.

**Hirsch Bros.**—Dealers in Watches and Diamonds and Manufacturers of Jewelry, No. 23 Maiden Lane, N. Y.

**Jandorf, P. & Bro.**—Importers of Watches and Jewelry, 196 Broadway.

**Kennedy, Frank S.**—Manufacturer and Wholesale Dealer in Jewelry and Gold and Silver Thimbles. No. 13 Maiden Lane, New York.

**Lissauer & Sondheim.**—Wholesale Jewelers and Jobbers in American Watches, No. 12 Maiden Lane, N. Y.

**Marx, Kossuth & Co.**—Importers of Watches and Dealers in Jewelry. 39 Maiden Lane, N. Y.

**May, Henry.**—Importer and Wholesale Dealer in Watches and Diamonds, and Manufacturing Jeweler. 19 John St., N. Y.

**Mayer, B.**—Manufacturer of Fine Jewelry, and Dealer in Watches, 71 Nassau Street, cor. John Street, New York.

**Myers, S. F. & Co.**—Manufacturing and Wholesale Jewelers—all grades. Importers of Watches. Illustrated Catalogue to the trade. 179 Broadway, N. Y.

**Oppenheimer Bros. & Veith.**—Dealers in Watches and Diamonds, and Manufacturing Jewelers, No. 35 Maiden Lane.

**Scott, J. T. & Co.**—Importers of Watches, and Manufacturers of Jewelry, and Jobbers of all Grades of American Watches, 4 Maiden Lane.

**Smith & Knapp.**—Wholesale Dealers in American and Swiss Watches, Diamonds, Gold and Plated Jewelry and Gold Chain. 182 Broadway, N. Y.

**Steele, J. W.**—Successor to Brainerd, Steele & Co., Manufacturer of Fine Jewelry and Brainerd's Patent Lockets. No. 9 Maiden Lane, N. Y.

**Stern Brothers & Co.**—Importers of Swiss Watches and wholesale dealers in American Watches, &c., 39 Maiden Lane.

**Stern & Stern.**—Dealers in Watches, Jewelry and Diamonds. No. 6 Maiden Lane, N. Y.

**Stites, D. H. & Son.**—Manufacturers of Fine Jewelry, Rolled Plated Goods and Chains, Parisian Diamond Rings, Studs and Earrings a specialty. 41 Maiden Lane, N. Y.

**Strauss, Jacob.**—Full Line of Gold and Plated Jewelry, and Importer of Watches. 18 John Street, New York.

**Thrall, E. A.**—Wholesale Dealer in Watches and Jewelry. No. 1 Maiden Lane, N. Y.

**Trier Bros.**—Importers of Garnet, Whitby Jet and Amber Jewelry, Silk Guards, Opera, Field and Marine Glasses, Pearl Card Cases. Also a full line of Gold and Plated Jewelry. 15 Maiden Lane, N. Y.

**Wheeler, Parsons & Hays.**—Manufacturers of Fine Jewelry, Watch Cases, Gold Chains, &c. and Dealer in American and Swiss Watches, No. 2 Maiden Lane, N. Y.

**White, N. H.**—Jobber in American-Waltham Watches and Chronographs. Waltham make of 10-k., 14-k. and 18-k. Gold and Sterling Silver Cases; Filled Gold Cases. 11 Maiden Lane.

#### Watch Tools, etc.

**Keller, L. H. & Co.**—Importers of Watchmakers' and Jewelers' Tools, Materials, etc. 64 Nassau Street, N. Y.

**Zimmern, Henry.**—Importer of Watch Materials, Tools, and Optical Goods, No. 8 Maiden Lane, (first floor.) Sole Agent for A. Hugenin & Gravier. Mainsprings, New York.

#### PHILADELPHIA

**Bennett, Jacob & Son.**—Diamond Setters and Manufacturing Jewelers, 925 Chestnut St.

**Bernard & Co.**—Manufacturers of Fine Roman and Etruscan Jewelry. Designs of every description made to order, 123 & 125 South Eleventh Street, Philadelphia.

**Booz & Co.**—Makers of Fine Gold Watch Cases and Plain Gold Rings, also Dealers in all American Movements, Diamonds, Jewelry, etc. 108 South 8th Street, Philadelphia.

**Conover David F. & Co.**—American Watches, Wholesale Salesroom, Southeast corner 7th and Chestnut Streets, Philadelphia.

**Herold, Chas P.**—Successor to Hildebrandt, Herold & Co., Manufacturing Jeweler and Diamond Setter. Diamonds. 916 Chestnut Street.

**Krieder, Peter L.**—Manufacturer of Sterling Silver Ware. 618 Chestnut Street, Philadelphia.

**McCalk & Newman.**—Manufacturing Jewelers. Makers of the Original Gold Crown Filled Rings. No. 625 Arch St., Philadelphia.

**Morgan & Headly.**—Manufacturing Jewelers. Cameo Sets, Gold Sets, Roman Lockets, Rings, Coral Sets and a general line of rich goods. Corner 10th and Chestnut Streets, Philadelphia.

**Muhr's, H. Sons.**—Manufacturing Jewelers. Solid Gold and Filled Rings a specialty. 633 and 635 Chestnut Street, Philadelphia. 1½ Maiden Lane, New York.

**Peters, Reese S.**—Manufacturer of Patent Rolled Plate or Filled Watch Cases, Dealer in American Movements, 308 Chestnut Street, Philadelphia.

**Rosenthal, G. F. C.**—Manufacturing Jeweler and Diamond Setter. Engraving and Designing of Monograms a specialty. No. 917 Sansom Street.

**Scherr, L. A. & Co.**—Wholesale Dealers in Watches Silver-Plated Ware, Spectacles, Fancy Goods, Watch Materials, etc. 726 Chestnut Street.

**Sheafer, W. H. & Co.**—Manufacturing Jewelers. Specialty: Band Bracelets. Factory, 612 and 614 Chestnut Street, Philadelphia. Office, 15 John Street, New York.

**Simons, Brother & Co.**—Manufacturers of Fine Jewelry, Canes, Thimbles, Chains. 611 and 613 Sansom Street.

#### CHICAGO.

**American Watch Company.**—of Waltham, Mass. No. 102 State Street, Chicago.

**Clapp & Davies.**—Wholesale Jewelers, 63 and 65 Washington Street. Catalogue and price list issued to watchmakers and jewelers.

**Dennison Manufacturing Co.**—Manufacturers of Jewelers' Paper Boxes, Morocco Cases, Tags, Cards, Pink and White Cotton, Tissue Papers, Sealing Wax, &c., &c., 102 Madison St., Chicago. Boston, New York, St. Louis, and Philadelphia.

**Gilbert Wm. L., Clock Co.**—Manufacturers of Clocks, Regulators, and Time Pieces, and Clock Material of every description, 54 and 56 Madison Street, Chicago.

**Giles, Bro. & Co.**—Manufacturers and Jobbers in Watches, all classes of Jewelry, Materials, Clocks, Silver Ware, &c. Illustrated catalogues furnished to dealers on application. 101 & 103 State St.

#### NEWARK.

**Baker & Co.**—Gold, Silver and Platinum Refiners, Assayers and Sweep Smelters. 408 New Jersey Railroad Avenue, cor. Murray St., Newark, N. J.

**Diefenthaler Bros. & O'Donnell.**—Manufacturers of Fine Jewelry, Lace Pins, Ear Rings and Patent Spring Bangles a Specialty. 36 Crawford Street, Newark, N. J.

**English & Miller**—Manufacturers of Gold Jewelry, Diamond and Fancy Stone Rings, Roman Locketts, Bangle and Flexible Bracelets, Knife Edge Lace Pins and Sets, Scarf Pins and Link Buttons. 61 and 63 Hamilton St., Newark.

**Felger, F. & F.**—Manufacturing Jewelers. Specialties:—Roman Band Bracelets, Lace Pins, Scarf Pins, Ball and Fancy Ear Rings. No. 477 Washington Street, Newark, N. J.

**Fiedler, Herrman**—Successor to Kurze & Fiedler, Engraver, Die Sinker and Press Tool Maker, 363 Market Street, Opposite Pennsylvania R. R. Depot, Newark, N. J.

**Glorieux, W. L.**—Assayer, Refiner and Sweep Smelter. 13 and 15 Franklin Street, Newark, N. J.

**Hopper & Wilson**—Manufacturers of Fine Jewelry, No. 8 Maple Place, Rear 44 Green St., Newark, N. J.

**Huger & Heitlinger**—Manufacturers to the Jobbing Trade only. Makers of Roman, Stone, Engraved and Enameled Locketts a specialty. Also Sleeve Buttons, Collar Buttons and Studs. 477 Washington Street, Newark, N. J.

**Krippendorf, C. & Schuller, F.**—Machinists and Jewelers' Tool Makers. 19 Greene Street, Newark, N. J. Rolls, Dies, Cutters, and Drawplates of every Description made and repaired.

**Lelong, L. & Bro.**—Gold and Silver Refiners Assayers and Sweep Smelters, Southwest corner of Halsey and Marshall Streets, Newark, N. J.

**Milne, Alex.**—Manufacturer of Stem-winding Watch Crowns. 19 Ward Street.

**Regad, E. D.**—Lapidary. Specialty—Sardonyx, Black Onyx and Agates. 14 Oliver St., Newark.

### PROVIDENCE

**Arnold & Webster**—Manufacturers of Solid Gold Engraved Band Rings for the Jobbing Trade. 29 Point Street, Providence, R. I.

**Butts, Geo. F.**—Manufacturing Jeweler. Ladies' and Misses' Solid Gold Drops and Studs a Specialty. 119 Orange Street, Providence, R. I.

**Bradley, R. & Son**—Manufacturers of Solid Gold and Rolled Plate Jewelry. White Stone Goods a Specialty. 227 Eddy Street, Providence, R. I.

**Capron & Co.**—Manufacturers of Jewelry. Engraved Box Bracelets, Bangle Wire Bracelets, Original Lever Collar and Cuff Button. No. 407 Pine Street, Providence, R. I.

**Elmwood Paper Box Co.**—Makers of Jewelers' Cases, Trays, etc. Factory, 54 Greenwich St., Providence, R. I.

**Hamilton, William & Co.**—Manufacturers of Fine Rolled Plated Chains and Patent Band Bracelets. 116 Pine St., Providence, R. I.

**Hough, W. S., Jr., & Co.**—Manufacturers of the Hough, Jr., Rolled Plate Locketts, Charms and Pendants. For sale by all first-class Jobbers or Wholesale Jewelers in the United States and Canadas.

**Hutchison & Huestis**—Makers of Solid Gold Rings. Quality guaranteed. For the Jobbing Trade only. 185 Eddy Street, Providence, R. I.

**Irons, Chas. F.**—Manufacturer of Solid Gold Jewelry. Specialty, Emblems, Pins and Charms, Masonic, Odd Fellows, etc. 102 Friendship St.

**Pitts & Hicks**—Manufacturers of the Excelsior Button and Eclipse Lever Button, also a line of White Stone Gold Goods and a fine line of Lace Pins and Drops in Rolled Plate Goods. 120 Dorrance Street, Providence, R. I.

**Taylor, Geo. H. & Co.**—Watchmakers and Wholesale Dealers in Watches, Clocks, Watch and Clock Material, Tools, Spectacles, Eye Glasses, &c. Particular attention given to trade work. 136 Westminster Street (Room 1), Providence, R. I.

### PAWTUCKET.

**Fuller, Geo. H. & Son**—Jewelers' Findings, Gold, Silver, Gold Plated and Fire Gilt. Pin Stems, Joints, Catches, Split Rings, Chain Hooks and Swivels, Ear Wires, Chain Bars, etc. 99 Exchange Street, Pawtucket, R. I.

### CINCINNATI.

**Holland, John**—Manufacturer of Gold Pens, Pencils and Pencil Cases, Gold Toothpicks, etc. Nos. 19 and 21 W. 4th St., Cincinnati, Ohio.

### BOSTON.

**Boston Watch Case Co.**, makers of Watch Cases. Especial attention given to Repairing. 1, 3 & 5 Province Court, Boston, Mass.

**Boyce, E. J.**—Manufacturer of Solid Gold Jewelry. Rings a Specialty. 383 Washington St., Boston, Mass.

**Weber, H. & Co.**—Wholesale Jewelers, Importers and Jobbers of Fine Watch Materials, Jewelers' Findings, Tools, etc., Optical Goods and Silk Guards. Agents for Whitcomb, Standard and Stark's Lathes. 424 Washington St., Boston, Mass.

### BUFFALO.

**Oliver, W. W.**—Manufacturer of Hand and Power Rolling Mills for Jewelers and Silversmiths, 39 Clinton Street, Buffalo, N. Y.

### CLEVELAND.

**Chandler, J. M. & Co.**—Manufacturers of the Patent Embossed Bracelet and Jobbers in all kinds of Clocks, Watches, Jewelry, Tools, Materials, etc. 185 Superior St., Cleveland, O.

### LANCASTER.

**Bowman & Musser**—Jobbers in Watches, Clocks, Chains, Fine Tools and Materials. 20 East Chestnut Street, Lancaster, Pa.

### PITTSBURGH.

**Goddard, Hill & Co.**—Wholesale Dealers in American Watches, Jewelry, Silverware, Clocks, Materials, &c., 43 Fifth Avenue, Pittsburgh, Pa.

**Hodge, Slemmons & Co.**—Wholesale Dealers in American and Swiss Watches, Diamonds, Gold and Plated Jewelry, Clock Material, etc. No. 77 Fifth Ave., Pittsburg.

### NEW BEDFORD.

**Nye, W. F.**—Manufacturer of Watch, Clock and Chronometer Oils, New Bedford, Mass.

**Wheeler, G. B.**—Manufacturer of Watch and Chronometer Oils, New Bedford, Mass.

### WORCESTER.

**Washburn & Mo n Manufacturing Co.**—Makers of Fine Watch Mainsprings, Worcester, Mass. 16 Cliff Street, New York. 107 to 109 Lake Street, Chicago, Ill.

### WINCHESTER.

**Goodell & Winn**—Manufacturers of American Watch Hands, Winchester, Mass.

### ALBANY.

**Reiss, Chas.**—31 and 33 So. Pearl Street, Albany, N. Y. Importer of Watch Tools and Material; General Supply; Low Prices. Repairing for the Trade.

### CANADA.

**Ellis, P. W. & Co.**, No. 31 King street, East Toronto, Ontario, Manufacturing Jewelers, Watchmakers, Importers and Jobbers of Watchmakers, and Jewelers' Tools, Materials, General Supplies and American Jewelry. Correspondence solicited with manufacturers of Novelties or specialties in American Tools and Jewelry.

GEO. W. DUBOIS.

F. N. NAUMAN.

## GEO. W. DUBOIS & CO.,

IMPORTERS OF

## Watches & Optical Goods.

ALL STYLES AND QUALITIES OF

SPECTACLES AND EYE-GLASSES.

## Longines' Watches and Movements,

The Watches in Gold, Silver and Nickel Cases of New and Handsome Patterns. The Movements fit 18 size Waltham Stem Winding Hunting Cases.

36 Maiden Lane, New York.

ORDERS BY MAIL RECEIVE PROMPT ATTENTION.

## BARNES' No. 4 LATHE, For the Heavier Work of Jewelers.

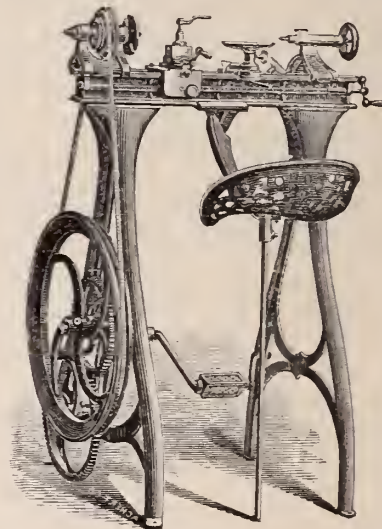

Barnes' Patent Foot and Steam Power Machinery. Complete outfits for Actual Workshop Business. Lathes for wood or metal. Circular Saws, Scrott Saws, Formers, Mortisers, Tenoners, etc., etc. Machines on trial if desired. Descriptive Catalogue and Price List Free.

W. F. & JOHN BARNES,  
2088 Main Street, ROCKFORD, ILL.

## EXCELSIOR'S

Practical Treatise

ON THE

## BALANCE SPRING

Including Making and Fitting Hair Springs, Regulating, etc.

Also containing the Adjustment of Watches and Chronometers for Isochronism, Positions, Heat and Cold and Rate.

PRICE, \$3.50.

D. H. HOPKINSON,  
42 Nassau Street, New York.

## SPECIAL NOTICES.

**Notices under this heading, not to exceed Six Lines, \$1.00 each insertion.**

Advertisers having letters addressed in care of this office, must inclose postage for answers forwarded.

WILL THE party who advertised in this column under the name of "Seller" send his name and address to this office.

WANTED AT ONCE—A thoroughly competent watchmaker and engraver combined. Freeman & Crankshaw, Atlanta, Ga.

A FINE BLISS transit instrument costing \$125 new, to sell or trade for an American lathe. Address C. R., care Jewelers' Circular.

AN EXCELLENT gas melting furnace for sale, with extra clay linings. Capacity, 400 dwts. Price \$25. Cost, \$30. Woglom & Miller, 34 John street, New York City.

FOR SALE—New flat rolling mills, rolls 5 inches long. Made by Lodge & Son. Cost \$250. Sell for \$225. Address J. L. Clark, Refiner, 823 Filbert street, Philadelphia, Pa.

SEND FOR "How to Repair Music Boxes" with illustrated price list of material; price 25 cents. No watchmaker should be without it. Jacot, Juillerat & Co., 37 Maiden Lane, New York.

WANTED—A good, competent and first-class jeweler and salesman to speak German. Answer, stating salary expected and giving good references. Address G. E. R., care Jewelers' Circular.

MOSELEY & CO., Elgin, Ill., manufacturers of the "Moseley" Lathe, with full line of fixtures and attachments. Designed especially for the watchmaker and repairer. Combining accuracy, durability, convenience and style.

ENGRAVER WANTED—Competent to act as salesman. Must be expert in monograms, also script lettering. Furnish best of references as to ability and integrity. Address, stating wages, George H. Ford, New Haven, Conn.

WANTED—A partner in the jewelry business in a western town of 15,000 inhabitants. Capital required \$5,000 to \$7,000. Must be young and a good business man. Address "Partner," care T. Kearney, 133 State street, Chicago.

WANTED—By July 1st a good reliable watchmaker and when needed will act as salesman. Must be of sober and steady habits. Engraving and jobbing not required. State wages and reference. Address John H. Fearey, 729 Broad street, Augusta, Ga.

FOR SALE—Oldest, leading and best paying jewelry store in best county in southern Michigan. Best location in town, long lease, low rent. Good excuse for selling. Inspection invited. \$3,000 to \$4,000 required. Address X Y Z, care Jewelers' Circular.

JEWELRY business in a mining town of 1,200 inhabitants. Established 15 years, no competition within 16 miles, for sale cheap. This is a splendid opportunity for any jeweler. Large run on repairing. Address immediately, C. Wiseman, East Brady, Pa.

FOR RENT—Desk and vault room in the Jewelers' Exchange Building, corner State and Washington streets, Chicago. Fire-proof building. Fire and burglar-proof vault. Suitable for manufacturing jewelers or importers office. Logan & Baro, 104 State st., Chicago.

FOR SALE—A first-class jewelry business in Los Angeles, the principal city of southern California. Stock can be "scaled" any where from \$2,500 to \$15,000. Inducements offered to the right party and liberal terms made. For particulars apply to Giles, Bro. & Co., Chicago.

FOR SALE—Stock and fixtures of leading jewelry store in a city of 8,000 inhabitants. One of the best locations in the southern part of Maine. Capital required from \$3,000 to \$6,000. Reason for selling poor health. Address, for particulars, W. L., care Jewelers' Circular.

FOR SALE—Rare opportunity—The entire stock and fixtures of an old and well established jewelry business. The best run of work in the upper part of 6th avenue, N. Y. City. Satisfactory reasons given for selling. For terms, etc. address to Henderson & Winter, 15 Maiden Lane, N. Y.

GEORGE E. WILKINS, manufacturer and importer of cutters for watchmakers' use, stem-winding cutters of all the different forms, rounding up cutters of the finest quality, also ratchet cutters. A large stock of second hand and new marine chronometers. No. 21 South Salina street, Syracuse, N. Y.

A WATCHMAKER, fully competent, wishes to change his present location about October 1st, 1884. Is 26 years of age and single, with 8 years' experience, has a complete set of tools, American lathe, etc. California or Texas preferred. Is at present with J. W. Forney, Steubenville, O. "Correspondence solicited.

FOR SALE—First-class jewelry store in town of 8,000 population and thickly settled country around. Leading store of the place in stock and trade. Will invoice stock and fixtures about \$5,000. Reasons for selling are not a practical jeweler and want to move west. Address C. C., care Jewelers' Circular.

A SITUATION with a first-class watchmaker is open to a young man of good character who has had several years' experience in watch work and wishes to improve his knowledge of repairing. Applicant must furnish own tools. Address, stating ability and amount of wages expected, South, care Jewelers' Circular.

FOR SALE—Stock, fixtures and tools of a profitable jewelry business. Fixtures and stock comparatively new, from \$5,000 to \$7,000; will reduce it to \$3,000. An old established business situated in a thriving southern town of 4,500 inhabitants. Satisfactory reasons for selling. This is a rare opportunity for a responsible man. Address W. B. P., care Jewelers' Circular.

FOR SALE—Stock of jewelry, watches and clocks in one of the most flourishing towns in Minnesota. Two railroads, population 5,000. Fixtures and stock in first-class condition. A good chance for an enterprising watchmaker. Must be sold before August 1st owing to outside business. Will dispose of above at a bargain. Terms easy. Address H. V. Birckett, Owatonna, Minn.

TO THE TRADE.—I make a specialty of supplying the Trade with stones for jobbing purposes. Parties having jewelry out of which the stones have been lost, sending their orders by mail or express, will have them promptly attended to. A large stock of cameos, pearls, turquoise, garnets, amethysts, doublets, foil backs, white and colored imitation stones on hand. All kinds of setting done for the Trade. W. Archibald, 73 Nassau street, New York.

FOR SALE—One of the cleanest stocks and best locations in the U. S. for the size of the city. Stock and fixtures invoice about eight thousand. Has paid over seventy-five per cent. net profit each year for the last three years. Store is brick, iron columns, plate glass front and one of the neatest buildings and store fixtures in the state. Will sell store or rent it. Counters are low and cases high and all plate glass. Will sell tools and materials or without. Population thirty-five hundred. Two R. R., five churches, public schools, state agricultural college in flourishing condition, opera house, city fire department and water works, good hotels. Object of selling, simply this and nothing more: We have all the money we need and made every cent except twenty dollars, our original capital, right in this city and in this business in the last five years, and wish to retire from business. City in an agricultural part of the state and growing rapidly. No we do not wish to trade it for cats or dogs or real estate, but those having cash or bankable security and wishing to invest in the jewelry business will do well to investigate. None others need apply. Address E. W. Reed, Fort Collins, Colorado. Reference, Alkin, Lambert & Co., 23 Maiden Lane, N. Y.

## BUYERS' DIRECTORY.

## NEW YORK.

## Assayers and Sweep Smelters.

Wundoehl, H.—Gold and Silver Refiner, Assayer and Sweep Smelter. 21 John Street, N. Y.

## Badges and Medals.

Stockwell & Newman—19 John Street. Manufacturers of Badges, Medals and Presentation Pieces in Gold and Silver. Also Jewelry and Mounters of Diamonds. Designs supplied.

## Band Rings.

Knapp, Charles, 41 Maiden Lane, N. Y. Specialty: Superior Band Rings, also Ring Shanks & Heads for Seal and Diamond Rings.

## Black Onyx Jewelry.

Cox & Sedgwick—Manufacturers of Black Onyx Jewelry, No. 26 John St. New York.

Lawson, Samuel—No. 18 John Street. Manufacturer of Black Onyx Jewelry. Coral repaired for the trade. Goods sent on approval to responsible dealers.

Woglom & Miller—Manufacturers of (exclusively) Black Onyx Jewelry, 32 & 34 John St., N. Y.

## Blue Enameled Locketts.

Bissinger, Philip & Co.—Importers of Diamonds Pearls and Precious Stones. Agent for the Bohemian Garnet Goods. Blue Enameled Locketts, 22 John St., N. Y.

Emrich, I.—Importer of Blue Enameled Locketts, Ear Drops and all kinds of Enameled Jewelry; also Enamel for Manufacturing purposes. 66 Nassau St., N. Y.

Hess & Schliesser—Importers of Diamonds, Fine Jewelry and Novelties in French Goods. Specialties: Gold and Blue Enameled Locketts, Charms and Crosses. 2 John Street.

## Bohemian Garnet Jewelry.

Bissinger, Philip & Co.—Importers of Diamonds, Pearls and Precious Stones. Sole Agent for the Bohemian Garnet Jewelry. Blue Enameled Locketts. 22 John St.

Emrich, I.—Importer of Half Pearls and Bohemian Garnet Jewelry. Designs made to order in our European Factory at moderate prices. 66 Nassau St., N. Y.

## Clock Companies.

Ansonia Clock Co.—Manufacturers of every description of Clocks. 11 to 21 Cliff street, New York.

Kroeber, F.—Manufacturer and Dealer in American and French Clocks, No. 14 Cortlandt Street.

New Haven Clock Co.—16 and 18 Park Place, N. Y.

Seth Thomas Clock Co.—20 Murray Street, N. Y.

Waterbury Clock Co.—M. Bailey, Treasurer, Manufs and Jobbers, No. 4 Cortlandt St., N. Y., and No. 197 State Street, Chicago.

Welch, E. N., Manufacturing Co.—Manufacturers of American Clocks. No. 6 Warren St.

Wm. L. Gilbert Clock Co.—No. 6 Murray Street, Manufacturers of Clocks. Factories, Winsted, Conn.

## Cameo Cutters, Etc.

Feiter, Theodore—Cameo and Intaglio Engraver. Patentee of the Cameo-Intaglio. No. 3 Maiden Lane, New York.

## Charms &amp; Gold Watch Keys.

Rupp & Held,—Manufacturing Jewelers, Charms and Gold Watch Keys, with French and English Rackets, a specialty. 15 John St., N. Y.

## Crucibles.

Berge, J. & H.—Established 1850. Importers of Sand Crucibles, Covers, Chemical Porcelain, Glassware, and Jewelers' and Assayers' Supplies. 95 John Street, N. Y.

## Cutlery.

Harrison Bros. & Howson,—Manufacturers of Fine Ivory and Pearl Table and Pocket Cutlery, Carvers in Cases; Nutpicks, Nutcracks and goods suitable for the jewelry trade. 126 Chambers Street. W. C. Burkinshaw, Sole Agent.

## Diamond Brokers.

Anderson, Otis—Diamond Merchant and Broker, always ready to pay cash for bargains in Diamonds and Precious Stones, 4 & 6 John Street, N. Y.

Bernhardt, Richard—Diamond Broker and Importer, 65 Nassau Street (Room 6), N. Y. Paris, 20, rue des Petites-écuries.

Friend S. & Son—Brokers and dealers in Diamonds 33 John Street, cor. Nassau St. New York.

Herbert, R. J.—Diamond Broker and Dealer, 26 Maiden Lane.

## Diamond Importers.

Bernhard, A. & Co.—Importers of Diamonds and Manufacturers of First-class Diamond Jewelry, Diamond Settings for Manufacturing Jewelers. Catalogue of Designs for the Trade free of charge. No. 2 Maiden Lane, New York.

Bissinger, Philip & Co.—Importers of Diamonds, Pearls and Precious Stones. Agent for the Bohemian Garnet Goods. Blue Enameled Locketts, No. 22 John St., N. Y.

Bruhl, D. & M.—Established in 1848. 14 Maiden Lane, N. Y.; 111 Broad Street, Providence, R. I.; 14 Rue Bleue, Paris.

Brunswick, S. & Co.—Importers of Diamonds, 17 Maiden Lane, New York. Paris, Rue Lafayette. Amsterdam, Damsstraat.

Citroen, L. B. & Co.—Diamonds. 21 John St., N. Y. Cutting Works, 57 & 61 Rapenburgerstraat, Amsterdam. House in Paris, 44 Rue Laffitte.

Faulkenau, Oppenheimer & Co.—Manufacturers. Diamonds and Diamond Jewelry. 40 Maiden Lane, N. Y.

**Fera, Henry**—Importer of Diamonds, and Manufacturer of Fine Diamond Jewelry. 4 & 6 John Street, New York. Amsterdam, Holland, 23 Loojersgracht.

**Fox, M. & Co.**—Importers of Diamonds, Rubies, Sapphires and Fancy Gems. No. 1 Maiden Lane, New York

**Hedges, Wm. S. & Co.**—Importers of Diamonds. No. 170 Broadway, corner Maiden Lane.

**Henle Brothers**—Importers of and Wholesale Dealers in Diamonds only. No. 16 Maiden Lane, N. Y. Paris, 20 Rue Laffitte.

**Kuhn, Doerflinger, & Co.**—Manufacturing Jewelers and Importers of Diamonds, 18 John Street New York

**Leberthon, L. M.**—Importer of Diamonds and Manufacturer of Fine Jewelry. 14 John Street, N. Y.

**Miller Bros.**—Importers of Diamonds and Manufacturers of Fine Diamond Jewelry and Mountings.

**Neresheimer, E. Aug. & Co.**—Importer of Diamonds. No. 21 Maiden Lane, New York.

**Randel, Baremore & Billings**—Importers of Diamonds, corner Maiden Lane and Nassau St.

**Saril, S.**—Importer of Diamonds, 182 Broadway, N. Y. Branch of Vve. H. A. Marchand & Frères, 47 Rue Le Peletier, Paris.

**Saunders & Ives.**—Importers of Diamonds and other Precious Stones. No. 26 Maiden Lane.

**Smith, Alfred H & Co.**—Importers of Diamonds, No. 182 Broadway.

**Tannenbaum, L. & Co.**—Importers of Diamonds and Precious Stones. Steam Lapidary Works. Oriental Stones Cut and Polished a specialty. 65 Nassau St., N. Y.

**Taylor & Brother.**—Importers of Diamonds and Diamond Jewelry. 860 Broadway.

**Wickham, D. H. & Co.**—Importer of Diamonds. No. 31 Holborn Viaduct, London, 24 Maiden Lane, New York.

**Wolf, G. A.**—Importer of Diamonds, Rubies, Sapphires, Pearls, and other Precious Stones, 65 Maiden Lane, New York. 12 Rue de Chateaudun, Paris.

#### Diamond Jewelry.

**Baldwin, Sexton & Peterson**—Importers of Diamonds and Manufacturers of Diamond Jewelry, 692 and 694 Broadway, N. Y.

**Bornemann, Louis.**—Importer of Diamonds and Manufacturer of Rich Diamond Jewelry, 19 John Street, New York.

**Chalumeau, D.**—Diamond Jeweler and Manufacturer of Mountings. Novelties and Artistic Jewelry. No. 3 Maiden Lane, New York.

**Goldsmith, Ingomar & Co.**—Manufacturers of Diamond Mountings and Diamond Jewelry, 61 Nassau Street, New York.

**Goldsmith & Co.**—Manufacturers of Fine Diamond Mountings and Diamond Jewelry. Lace Pins, Ear Rings and Rings a specialty. 49 Maiden Lane, N. Y.

**Hartje, G. & F.**—Manufacturers of Diamond and Fine Jewelry, 39 Union Square, N. Y.

**Haug, John**—Manufacturer of Fine Diamond Mountings, etc. No. 130 Fulton St., N. Y.

**Heller & Bardel.**—Manufacturers of Diamond and Pearl Jewelry, and Dealers in Diamonds, Pearls, &c. 13 John Street.

**Jeanne Brothers.**—Manufacturers of Diamond Mountings & Rich Jewelry. 1 Maiden Lane.

**Lacroix & Verpillier.**—Manufacturers of Fine Gold Jewelry. Diamonds a specialty. 173 Broadway, N. Y.

**Luthy, A. & Co.**—Manufacturers of Fine Diamond Mountings, Lace Pins, Ear Rings, Rings, Knife Edge Bracelets, Hair Ornaments, etc., a Specialty. 35 Ann Street, corner Nassau Street, N. Y.

**Mitchell, Noah**—Manufacturer of Diamond Jewelry and Diamond Mountings. 52 Maiden Lane, New York.

**Nissen, Ludwig & Co.**—Dealers in Diamonds and Diamond Jewelry. No. 51 Nassau Street, New York, near Maiden Lane.

**Rosswog, C. & Son**—Manufacturers of Rich Diamond Goods. Nos. 5 and 7 Maiden Lane, N. Y.

**Scheer, William**—Diamond Jeweler and Manufacturer of Mountings, Novelties in Artistic Jewelry, 859 Broadway, near 17th St., N. Y.

**Stern, Louis**—Manufacturing Jeweler. Diamond Mountings a Specialty. 8 & 10 John St., N. Y.

**Voelker, C. T.**—Manufacturer of 18-k. Diamond Mountings, Diamond Jewelry and Roller Chain Bracelets. 15 Maiden Lane, New York.

**Waterman & Lehmann.**—Manufacturing Jewelers and Dealers in Diamonds. Diamond Work, and Fine fancy Rings a specialty, any piece of single work made to order. 37 Maiden Lane, N. Y.

#### Diamond and Pearl Setter, &c.

**Danziger, H.**—Diamond and Pearl Setter, 116 Nassau Street, (Second Floor,) Room 6, N. Y.

#### Diamond Cutters.

**Levy, Herman.**—Importer, Cutter and Polisher of Diamonds. 105 Fulton Street, New York.

**Mendes, D. De S.**—Diamond Cutter and Polisher, 113 Nassau St., N. Y. Re-cutting, Repairing and Matching a Specialty.

#### Dials, &c.

**New York Dial Co.**—Manufacturers of Fine Watch Dials. Henry Abbott, Agent, No. 4 Maiden Lane, N. Y.

#### Enameled Clock Dials and Figures.

**Caeser Bros.**—Manufacturers of Enameled Clock Dials, also letters and numbers for signs. 230 and 232 East 25th Street, New York.

#### Enamelers, Etc.

**Nutt, J. D.**—Enameler on Gold, Silver, and Copper. Linen finished Buttons and Studs. Enameling in colors. 32 and 34 John Street, New York.

**Orr, J. C.**—Enameler on Fine Jewelry. Enameled in Colors. Linen Finished Buttons and Studs. Band Bracelets. No. 75 Nassau Street, N. Y.

**Orr, William N.**—Enameler on Fine Jewelry. Masonic Jewels and Badges a specialty. Linen Finished Work. 79 Nassau Street, Room 18, New York.

#### Engravers—Stone Seal, Etc.

**Fackner, Edward**—Carver, Engraver and Chaser on Jewelry and Pencil Cases, lettering, &c., 19 John Street.

**Holland & Gosling**—Stone Seal Engravers. Precious Stones inlaid and encrusted with Diamonds. No. 176 Broadway, New York, (fifth floor per elevator). Cameos cut and repaired.

**Knapp, Chas.** Engraver, Die Sinker & Stamper for Jewelry purposes. Ring Shanks & superior Band rings, 41 Maiden Lane, N. Y.

**Park, Wm.**—The Stone Seal Engraver. Arms, Crests, Monograms, etc., engraved on precious stones, 26 John Street, New York.

**Weston, James F.**—Stone Seal Engraver and incruiter of Precious Stones. Coats of Arms, Masonic, Odd Fellows, and other devices engraved. 32 John Street.

#### Fancy Goods, Clocks, Bronzes, Etc.

**Hinrichs, C. F. A.**—Importer of Fancy Goods, Glassware, China, Clocks, Bronzes, etc. 31 Park Place.

**Le Boutillier & Co.**—Importers of Fancy Goods, Clocks, Bronzes, &c., 33 West 23d Street.

**Straus, L. & Sons**—Importers of Potteries, Faïences, Bisque Figures and Rich Fancy Goods especially adapted for the Jewelry Trade. 40, 42 and 44 Warren Street, New York.

**Taylor & Bro.**—Importers of French Clocks, Bronzes, etc. 676 Broadway, N. Y.

**Young, J. M. & Co.**—Importers of Fine Parian, Lava, and Bisque Statuary, Bohemian, German and English Fancy Goods, 37 & 39 Murray St., New York.

#### Gold and Silver Cane Heads.

**Cuppia, L. A.**—Importer of Filigree Jewelry and Manufacturer of Silver and Gold Cane Heads and Novelties in Silver and Gold Jewelry. 19 Union Square, N. Y.

**Simons, Bro. & Co.**—Manufacturers of Gold Headed Canes. 611 and 613 Sansom street, Philadelphia.

**Smith, Rest Fenner & Co.**—No. 701 Broadway, Makers of Fine Gold and Silver Headed Canes.

#### Gold and Silver Plating, Etc.

**Bantle, A.**—Gold, Silver and Electro-Plating, 130 Fulton and 89 Nassau Streets, cor. Fulton Street, (Room 36,) N. Y. Watch Case Polishing.

**Jeandheur, F. & Son.**—Gold and Silver Electro Platers & Fire Gilders, coloring Etruscan and Gold Jewelry a specialty. 125 Fulton St.

**Klees & Magrath**—Gold and Silver Electro-Platers. Coloring Etruscan and Gold Jewelry a Specialty. 89 Nassau Street, New York.

#### Gold Chains, Etc.

**Beck, J. & Son**, Manufacturers of Fine Gold Chains and Chain Bracelets, 10 Liberty Place, near Maiden Lane, N. Y.

**Carter, Sloan & Co.**—Manufacturers of Fine Gold Chain, 15 Maiden Lane, New York.

**Edge, W. C. & Co.**—Manufacturers of the Celebrated Woven Fabric Gold Chain, No. 15 John Street.

**Kaufmann Bros.**—Manufacturers of Gold Chains, and Chain Bracelets, 12 First Street; Factory, 331 and 333 Bowery, N. Y.

**Kohn, Alois & Co.**—Manufacturers of Gold Chains, 9 Maiden Lane, N. Y.

**Saxton, Smith & Co.**—Manufacturers of Fine Gold Chain, No. 14 John Street, N. Y.

**Schlag, Chas.**—(Late Nordt & Schlag), Manufacturer of Gold Chains, Chain Bracelets and Fine Jewelry. 177 Broadway, New York. All kinds of Jobbing promptly attended to.

**Smith, W. & Co.**—Manufacturers of Gold and Silver Chains, Jewelry, etc. No. 25 Maiden Lane, N. Y.

#### Gold Pens, Etc.

**Aikin, Lambert & Co.**—Manufacturers of Choice Gold Pens, Cases, Holders, Toothpicks, etc., 23 Maiden Lane, N. Y.

**Fairchild, Leroy C. & Co.**—No. 10 Maiden Lane, New York. Manufacturers of Gold Pens, Pencils, etc.

**Fairchild, Leroy W.**—Manufacturer of Gold Pens, Pencil Cases, Tooth Picks and Novelties in Charms. No. 18 John St., N. Y.

**Foley, John**—Manufacturer of Fine Gold Pens, Pencils and Charms. 2 Astor House, N. Y.

**Gerow, Joseph U.**—Manufacturer of Pencil and Pen Cases for the Jobbing Trade only. No. 44 State Street, (near South Ferry,) Brooklyn, N. Y.

**Hicks, W. S.**—Established 1848. Manufacturer of Fine Gold Pens, Pencil Cases, Tooth Picks, and Charm Novelties of every description. No. 20 Maiden Lane.

**Johnson, E. S. & Co.**—Manufacturers of Gold Pens, Pen Holders and Pencils. Cor. Maiden Lane and Nassau Street, New York.

**Smith, H. M. & Co.**—Manufacturers of Gold Pens and Holders, Tooth Picks, Pencils, etc. Sole Manufacturers of Sprague's Patent Gold Fountain Pen. Importers of Nickel and Silver Watches. 173 Broadway, New York.

#### Gold Rings.

**Barnet Bros.**—Manufacturers of Stone and Seal Rings, 15 John Street, New York. Factory, Newark, N. J.

**Bowden, J. B. & Co.**—Manufacturing Jeweler.—Solid Gold Rings a specialty, 1 Maiden Lane.

**Dattelbaum & Friedman**—Manufacturers of Fine Cameo and Seal Rings, all kinds of Fancy Rings and Diamond Mountings. 10 Maiden Lane.

**Cable, Geo. W.**—Manufacturing Jeweler. Plain and Band Rings a Specialty. No. 52 Maiden Lane, N. Y.

**Ely, W. H.**—Manufacturer of Solid Gold Rings of every description. No. 58 Nassau Street.

**Henrich, R.**—No. 35 Maiden Lane, Manufacturer of Gold Rings; also Patentee and Manufacturer of the Celebrated Self-Sizing Ring

**Hutchison & Huestis**—Makers of Solid Gold Rings. Quality guaranteed. For the Jobbing Trade only. 196 Broadway, N. Y.

**Kroll, H.**—Manufacturing Jeweler. 78 Nassau Street, New York. Specialty: Solid Gold Stone Rings. All kinds of Fine Jewelry made to order, also Repairing for the Trade.

**Ostby & Barton**—Manufacturers of Plain and Engraved Solid Gold Band Rings. Office, 176 Broadway, N. Y. Factory, 80 Clifford Street, Providence, R. I.

**Peckham, Wm. H.**—Manufacturers of Solid Gold Seamless Rings. and Fancy Embossed Rings, Patent Spectacles, Jewelry, etc. No. 4 Liberty Place N. Y.

**Radler, K.**—Manufacturing Jeweler. Gold Rings and Locketts a specialty. No. 179 Broadway, New York.

**Sauter, L.**—No. 1 Maiden Lane, New York, Manufacturer of Stone Rings of every description, as Diamond, Cameo, Onyx Turquoise, etc., Scarf Pins, Scarf Rings, Studs and Buttons.

**Shafer & Douglass.**—Manufacturers of all kinds of Seal, Stone, Turquoise, and fancy rings. No. 7 Maiden Lane, N. Y.

**Thuerner & Church**—Manufacturers of Fine Gold Rings. No. 9 Maiden Lane, N. Y.

#### Hair Jewelry.

**Moutoux, Wm. E. & Co.**—Manufacturers of Fine Hair Mountings in Gold. Grand catalogues for the trade. 81 Nassau St., Rooms 1 and 2. Finest work and lowest prices

**Sauter, L.**—Manufacturer of Fine Gold and Hair Jewelry and Device Work. Pattern Book sent on application. No. 1 Maiden Lane, N. Y.

**Schwencke O.**—Manufacturer of Fine Hair Jewelry Orders from the country promptly attended to. No. 43 Maiden Lane.

#### Jewelry Cases, Fancy Boxes, Etc.

**American Morocco Case Co.**—7 and 9 Bond St., N. Y., make a specialty of Rich Jewelry and Silverware Cases for the fine Retail Trade. Also Improved Trays for Watches, Rings, etc.

**Braun, Chr. E.**—Manufacturer of Fine Jewelry Boxes and Trays for Show Cases and Trunks. No. 62 Chatham Street, New York. Trays for Show Cases and Trunks a Specialty.

**Bricka, C. A. & Co.**—Manufacturers of Morocco Cases for Cutlery, Silverware, Jewelry, etc. Sample Cards and Rolls. Cases in Rosewood, Black Walnut, etc. 52 Nassau Street, New York.

**Dennison Mfg Co.**—Manufacturers of Morocco, Plush and Velvet Jewelry and Silverware cases. New York, Boston, Philadelphia, Chicago, Cincinnati and St. Louis.

**Ettlinger, L. & Sons.**—Manufacturers of Fine Cases for Jewelry, Watches and Silverware. Trays for Travelers and Show Cases. Cases to Order a Specialty. No. 80 Nassau St., N. Y.

**Haensler, Chas. C.**—Manufacturer of Fine Morocco Cases for Jewelry and Silverware. Toilet Boxes, etc. Trays for Show Cases and Windows. 14 John Street, New York.

**Hebbard & Brother**—Manufacturers of Jewelry and Silver Ware Cases, and Fancy Wood Chests for Tea Sets and Flat Ware. 860 Broadway, New York.

**Kohn, Solomon & Co.**—Manufacturers of Fine Morocco Cases for Jewelry, Watches, etc. 43 Maiden Lane, New York.

**Lauten, Edw. A. & Co.**—No. 4 Great Jones St., Manufacturers of Fine Velvet, Brocade, Plush and Morocco Boxes, Patent Ring, Ear Ring and Gent's Scarf Pin Trays, Patent Watch and Bracelet Blocks, Window Decorations, etc.

**New York Morocco Case Co.**—Cases for Jewelry, Watches, Silverware. Boxes and Trays for Jewelers' Travelers. Show Cases and Window Fittings. No. 69 Nassau Street, New York.

**Sauer & Schroeter**—Successors to Loehr & Koerner, Manufacturers of Morocco, Velvet, Satin, Jewelry, Watches and Silverware Cases, Jewel, Work Boxes, etc., Fancy Trays and Store Fittings to order. 96 Liberty St.

**Schwarz, N.**—Manufacturer of fine Cases for Jewelry and Silverware, 866 Broadway, near 17th street, N. Y.

**Welch & Miller**—169 Broadway. Manufacturers of fine Morocco, Velvet, Russia, Brocade and Plush Jewelry Cases. Trays of every description; Jeweler's Cotton and Twine.

**Wiggers & Froelick**—No. 60 Nassau street—Manufacturers of Cases for Jewelry, &c., of every description. Trays for Show-cases, Stands for Show-windows, etc.

#### Jewelers' Findings.

**Dennison Mfg Co.**—Paper Jewelry Boxes, cards, tags, pink and white cotton, etc. etc. New York, Boston, Chicago, Cincinnati, Philadelphia, St. Louis.

**Ettlinger, L. & Sons.**—Manufacturers of Jewelers' Paper Boxes and Findings. Morocco Paper, Satin or Plush Lined Wooden Corner Stops Jewelry and Silverware Boxes. 80 Nassau Street, New York.

**Valfer, S. & Co.**—Manufacturers and Dealers in Jewelers' Boxes, Tags, Cards, Paper and Findings. Trays a specialty. Fancy Ornaments for Show Windows. 66 Nassau street, New York.

#### Jewelry Manufacturers.

**Aikin, Lambert & Co.**—Manufacturers General stock of Reliable Jewelry, 23 Maiden Lane.

**Alling, Isaac A. & Co.**—Manufacturers of Fine Gold Jewelry. Specialties: Wire Bracelets, Bangles, American Lever Sleeve Buttons. Bryant Building, Nassau and Liberty Streets, N. Y. Factory, Newark, N. J.

**Baldwin, Sexton & Perterson**—Manufacturers of Rich Jewelry, 692 and 694 Broadway, N. Y.

**Ball, W. H.**—Manufacturer of Gold Jewelry. Bracelets and Bangles of all kinds a specialty. 9 John Street, N. Y.

**Barthman, Straat & Co.**—Manufacturers of Fine Jewelry. Roman Goods, Rings, Diamonds. No. 43 Maiden Lane.

**Bissinger, Philip & Co.**—Importers of Diamonds, Pearls and Precious Stones. Sole Agents for the Bohemian Garnet Jewelry, Blue Enameled Locketts. 22 John St., N. Y.

**Brown, Thos. G. & Sons**—Manfr's of Rich Jewelry Necklaces, Locketts, Bracelets, Sleeve Buttons, etc., 860 Broadway, N. Y.

**Bryant & Bentley**—Manufacturing Jewelers. Rings a specialty. 12 Maiden Lane

**Carter, Sloan & Co.**—Manufacturing Jewelers, 15 Maiden Lane, New York.

**Champenois & Co.**—No. 5 Maiden Lane, manufacturers of Engraved and Enameled Gold goods, in Sets, Ear Knobs, Bracelets, Studs, Lace and Shawl Pins, Jet cluster and Onyx goods, also "Best Lever" Sleeve Buttons.

**Chatellier, Joseph F.**—Manufacturing Jeweler, No. 694 Broadway, N. Y.

**Churchill, Lewis & Co.**—Manufacturers of Fine Jewelry. 692 Broadway, cor. Fourth St., N. Y.

**Cook, George W.**—Manufacturer of Fine Jewelry and Locketts, 191 Broadway (over Mercantile Bank,) N. Y.

**Cottle S. Co.**—Manufacturers of Fine Jewelry. 860 Broadway, N. Y.

**Cox & Sedgwick**—Manufacturers of fine Onyx and Colored Jewelry. 26 John St., New York

**Day & Clark**—Manufacturers of Fine Jewelry, Lace Pins, Ear Rings, Studs, Locketts, &c., 10 Maiden Lane, New York.

**Geoffroy, Arthur R. & Co.**—Manufacturing Jewelers. Novelties in Diamond Goods. No. 23 Maiden Lane, N. Y.

**Greene Wm. C. & Co.**—Goldsmiths; Manufacturers of Rich Sets in Taper Wire Coral. Office, 192 Broadway.

**Griffith, H.**—Manufacturing Jeweler. Gold and Plated Jewelry. Scarf Pins a specialty. Nutry Alley, near Concord St., Brooklyn, N. Y.

**Groeschel & Rcsman**—Manufacturers of Fine Jewelry. No. 27 John Street, N. Y.

**Hartmann, P.**—Manufacturer & Importer of Fine Gold, Diamond, and Filigree Silver Jewelry, No. 36 Maiden Lane. P. O. Box 2,454.

**Hedges, A. J. & Co.**—Manufacturing Jewelers, 6 Maiden Lane.

**Henderson & Winter**—Jewelers, No. 15 Maiden Lane, New York. Specialties—Stone, Cameo, Onyx, Amethyst, Topaz, Pearl and Turquoise Rings.

**Hunt & Owen.**—Manufacturing Jewelers. Office 3 Maiden Lane.

**Jandorf, P. & Bro.**—Manufacturing and Wholesale Jewelers—all grades. Prompt Attention to Orders. We issue no catalogue. 196 Broadway, N. Y.

**Kipper, Vogel & Co.**—Manufacturing Jewelers, 17 Maiden Lane, New York.

**Kremenz & Co.**—Manufacturing Jewelers, No. 182 Broadway, N. Y.

**Kuhn, Doerflinger & Co.**—Manufacturers of Enameled and Roman Band Bracelets, also Fine Locketts Pendants and Lace Pins. 18 John street.

**Miller Bros.**—Manufacturers of Fine Jewelry, Diamond Goods, Sets, Lace Pins, Ear Rings, Scarf Pins, Sleeve Buttons, Studs, etc. 7 Maiden Lane, N. Y.

**Moore & Horton.**—11 Maiden Lane, Manufacturing Jewelers, Rings, Studs, Collars and Sleeve Buttons, Pins, Ear-rings, &c.

**Muhr's, H., Sons.**—Manufacturing Jewelers. Solid Gold and Filled Rings a specialty. Also Manufacturers of the celebrated Crown Filled Watch Case. 16 Maiden Lane, N. Y.

**Mulford & Bonnet**—No. 21 Maiden Lane, New York.

**Owen, G. & S. & Co.**—Manufacturing Jewelers. Office, No. 3 Maiden Lane.

**Richardson, Enos & Co.**—Manufacturers of Fine Gold Jewelry, Gold Chains, Locketts, Crosses and Necklaces. Colored and Etruscan Work. No. 23 Maiden Lane, New York.

**Richardson, J. W. & Co.**—Manufacturers of Jewelry. Masonic and other Emblems. 196 Broadway, N. Y. Manufactory, Providence, R. I.

**Riley, J. A. & Co.**—Manufacturing Jewelers. Etruscan Gold and Roman Bracelets, Lace Pins, Far Rings, Scarf Pins, Brooch Pins, etc. No. 860 Broadway, N. Y.

**Ripley, Howland & Co.**—Manufacturers of Fine Jewelry and Platinum Tipped Diamond Settings. No. 17 Maiden Lane, N. Y.

**Schwencke, Wm.**—Manufacturing and Jobbing Jeweler. Repairing a specialty. Orders promptly attended to. No. 43 Maiden Lane, N. Y.

**Sexton & Cole**—Manufacturing Jewelers, Colored Gold and Onyx Goods a specialty. No. 30 Maiden Lane.

**Sheafer, W. H. & Co.**—Manufacturing Jewelers, Specialty Bangles and Bracelets, 15 John St., N. Y.

**Stites' Sons, E.**—Manufacturers of Fine Jewelry. No. 14 John Street, N. Y.

**Street, Geo. O. & Sons.**—Established 1837. Makers of Fine Jewelry, strictly first-class goods of our own make. No. 15 John Street, New York.

**Thoma, Ernest**—Manufacturer of Fine Jewelry, Sleeve Buttons, Rings, Ear-rings, &c. No. 173 Broadway, N. Y. Factory, Hackensack, N. I.

**Ward, Thos. M.**—Manufacturer of Fine Jewelry, Diamond Mountings a specialty. No. 25 John Street, N. Y.

**Wienheim, J.**—Manufacturer of Fine Jewelry. Diamond Mountings a Specialty. 24 John St.

**Woglom & Miller**—Manufacturers of Black Onyx Goods exclusively. 32 & 34 John Street, N. Y.

#### Jewelry—Rolled Plate.

**Blackinton, W. & S.**—Manufacturers of the W. & S. B. Rolled Plated Chains. No. 11 Maiden Lane.

**Frick, John & Co.**—Fine Rolled Plate Jewelry of all kinds. Repairing of every description. 21 and 23 Maiden Lane, N. Y.

**Mauran, J. T.**—Manufacturer of Fine Rolled Plate Jewelry, No. 15 Maiden Lane, N. Y.

**Richards, E. Ira & Co.**—Manufacturers of Fine Rolled Plate Jewelry, No. 200 Broadway, N. Y.

**Jewelers' Tools, etc.**

- Fisher, James J.**—Dealer in Watchmakers' and Jewelers' Materials, Files, Tools, Silk Guards, Spectacles, etc. 695 and 697 Broadway, N. Y.
- Friedenthal, A. & Co.**—Importers and jobbers of Watchmakers' and Jewelers' Tools, Materials, etc. 43 Maiden Lane, N. Y.
- Friedlander, R. & L.**—Importers of Watchmakers' Tools and Materials. 65 & 67 Nassau Street. Branch Office, 264 Bowery.
- Koester, C. F.**—Importer and Manufacturer of Fine Tools, Files and Polishing Materials for Jewelers, Watch Case Makers, etc. 33 John St.
- Kurtz, F. P.**—Manufacturer of Jewelers Machinery, Tools, Rolling Mills, Presses, Polishing Lathes, &c. 97 Cliff St., N. Y.
- Levy, Dreyfus & Co.**—Importers and Jobbers of Watchmakers' and Jewelers tools and materials of every description. 11 Maiden Lane, N. Y.
- Reichhelm, E. P. & Co.**—Importers of Jewelers' Tools, Files, etc. Manufacturers of Brushes and Buffing wheels; also Patent Gas Furnaces for Melting, Plating, Enamelling, Annealing, etc. 80 Nassau St., N. Y.

**Lapidaries.**

- Fox, M. & Co.**—Practical Lapidaries, No. 1 Maiden Lane, New York.
- Graham & Co.**—Practical Lapidaries, Cutters and Polishers of all kinds of Precious Stones, Emeralds, Rubies, Sapphires, etc. Miner's Relics Cut, Polished and Mounted. Locket Glasses, 80 Nassau St., N. Y.
- Kordmann & Michel.**—Lapidaries. Dealers in Precious Stones. Cutting and Polishing Rubies, Sapphires and other Gems a specialty. Drilling done promptly. 59 Nassau St., N. Y.

**Masonic Jewelry.**

- Luther, John F.**—79 Nassau Street. Manufacturer of Fine Presentation Jewels for all Societies. Knights Templars, Crosses, Badges, &c.
- Wilkinson, C. B.**—Manufacturing Jeweler, 8 John St., N. Y. Medals, Badges and Masonic Jewelry, a specialty. Designs furnished free upon application.

**Optical Goods.**

- Friedlander, R. & L.**—65 and 67 Nassau Street. Dealers in Optical Goods.

**Opticians.**

- Burbank Manfg Co.**—Manufacturers of Spectacles and Eye Glasses of all descriptions, in gold, silver, etc., 14 Maiden Lane, N. Y.
- DuBois, Geo. W. & Co.**—Importers of Watches and Optical Goods. 36 Maiden Lane, N. Y.
- Levy, Dreyfus & Co.**—Importers of Spectacles and Eye Glasses and Optical Instruments of every description, No. 11 Maiden Lane, N. Y.
- Lorsch, Albert**—Manufacturer of the Patent Accommodating Spectacles and Eye Glasses in Gold, Silver and Steel, and other Optical Goods, 37 Maiden Lane, N. Y.
- Spencer Optical Manufacturing Co.**—Gold, Silver, Steel, Nickel and Plated Spectacles; Gold, Celluloid, Steel, Nickel and Rubber Eye Glass and Opera Glasses. 13 Maiden Lane, N. Y.
- Todd, James W.**—No. 20 Maiden Lane, N. Y. Wholesale Dealer in Optical Goods.

**Paper Boxes.**

- Waterbury Paper and Box Co.**, 27 to 35 Canal St., Waterbury, Conn., Manufacture Jewelers' and Silversmiths' Fine Paper Boxes. Quality guaranteed to be equal to the best made.

**Precious Stones, &c.**

- Bishop, Victor & Co.**—33 Maiden Lane, Importers of Precious Stones, Cameos, &c. Also Manufacturers of Coral Jewelry.

**Bissinger, Philip & Co.**—Importer of Diamonds, Pearls and Precious Stones. Agent for the Bohemian Garnet Goods. Blue Enameled Locket. No. 22 John St., N. Y.

**Breidenbach, R. A.**—Importer of Black Onyx, Diamonds, Pearls, Turquoise, Cameos, Sardonyx, Amethysts, Garnets, Topaz, Opals, Rubies, Sapphires, Hematite Balls, Foil Brilliants, Cat's-Eyes, Tiger Eyes, Doublets, Cabinet Specimens, etc. 85 Nassau Street, New York.

**Daue, Wm. & Co.**—Importer of Precious and Imitation Stones. No. 202 Broadway New York.

**Fox, M. & Co.**—Importers of Diamonds and other Precious Stones, No. 1 Maiden Lane, N. Y.

**Gruet, Jules.**—Importer of all Grades of Real and Imitation Stones. 14 John St., N. Y.

**Hahn & Co.**—Importers of Precious Stones, Cameos, Onyx, Pearls, Intaglios, Amethysts, Garnets, etc. 64 Nassau Street, New York.

**Kahn, L. & M. & Co.**—Importers of precious and imitation stones. 10 Maiden Lane, N. Y.

**Kipling, E. E.**—Importer of Precious and Imitation Stones. Manufacturer of the Patent Foil Solid Metal Back Rhine Stone Brilliant. No. 6 Maiden Lane, N. Y.

**Kipling, R. A.**—Precious and Imitation Stones, No. 24 Maiden Lane, N. Y. Manufacturer Cameos, Agates, Onyx, Etc., Oberstein, Germany. Commission Merchant, 49 Rue De L'Echiquier, Paris.

**Lorsch, Albert**—Importer of Precious Stones, 37 Maiden Lane, N. Y.

**Stirn, Max & Bro.**—Importers of Black Onyx, Cameos, Turquoise, Half Pearls, Sardonyx, Amethysts, Topaz, Garnets, Opals, Rubies, Sapphires, Cat's-Eyes, and all other imitation stones, 3 Maiden Lane, New York.

**Safes.**

**Butler, W. H.**—Fire and Burglar Proof Safes, 291 Broadway, N. Y.

**Silverware.**

- Gorham Manufacturing Co.**—Union Square.
- Knowles, J. B. & S. M.**—Manufacturers of Sterling Silverware, 20 Maiden Lane, N. Y. Factory, Providence, R. I.
- Shiebler, Geo. W.**—Manufacturer of Sterling Silverware. No. 8 Liberty Place, near Maiden Lane, N. Y.
- Whiting Manufacturing Co.**—Makers of Sterling Silver Ware. Broadway cor. 4th Street, N. Y.
- Wood & Hughes.**—Manufacturers of Fine Silverware. 16 John Street, N. Y.

**Silver Filigree Jewelry.**

- Cuppia, L. A.**—Manufacturer of Solid Silver Novelties, and Importer of Silver Filigree, 19 Union Square.
- Francesconi, Guido**—Importer of Silver Filigree Jewelry, 196 Broadway, New York.
- Hartmann, P.**—Manufacturer of Silver Filigree Jewelry. 36 Maiden Lane, N. Y.

**Silver Plated Ware.**

- Manhattan Silver Plate Co.**—Manufacturers of Silver Plated Ware. Showrooms, 23 John St. Factory, 301 to 305 East 22d St., cor. 2d Ave. Address all communications to Factory.
- Middletown Plate Co.**—Manufacturers of Superior Electro-Plate. Factories, Middletown, Conn., salesroom, 13 John Street.
- Rogers, Smith & Co.**—Manufacturers of Fine Electro Plated Ware. No. 46 E. 14th St., N. Y.
- Simpson, Hall, Miller & Co.**—Manufacturers of fine Silver-Plated Ware. No. 36 E. 14th Street.
- Schade, Henry.**—Manufacturer of White Metal and Plated Ware. Office, 26 John Street, N. Y. Price list and catalogue furnished on application.
- The Derby Silver Co.**—Manufacturers of Finest Quadruple Silver Plated Ware, Birmingham, Conn. New York office, 25 Maiden Lane.
- Webster, E. G. & Bro.**—Manufacturers of Fine Silver-Plated Ware. Office and warerooms, 14 Maiden Lane, N. Y.

**Show Cases, Etc.**

**Smith, B. & W. B.**—Manufacturers of Patent Improved Dust Proof Show Cases, with Perpendicular Sliding Doors, No. 220 W. 29th St., N. Y.

**Spectacle Case Manufacturers.**

- Bertine, P. D.**—Manufacturer of Spectacle and Eye-Glass Cases. 139 William Street, near Fulton St., New York.
- Koenen, A. & Bro.**—Manufacturers of Leather Spectacle and Eye-Glass Cases for the Jobbing Trade only. 81 Nassau St., N. Y.

**Stem Winding Attachments.**

**Abbott, Henry** Maker of Stem Winding Attachments, No. 4 Maiden Lane, N. Y.

**Swivels and Spring Rings.**

**Schwartz, V. & Co.**—Manufacturers of Gold Swivel and Chain Trimmings. 33 Barclay Street, New York.

**Thermometers, Etc.**

**Tagliabue, Giuseppe.**—manufacturer of Thermometers, Barometers and Hydrometers. Patentee and sole manufacturer of the U. S. Standard Hydrometer. 302 Pearl Street, near Beekman.

**Thimble Manufacturers.**

- Burbank Manufg Co.**—Manufacturers of Gold and Silver Thimbles, 14 Maiden Lane, N. Y.
- Ketcham & McDougall.**—Improved Gold and Silver Thimbles, Bryant Building, N. Y.
- Simons Bro. & Co.**—Manufacturers of Gold and Silver Thimbles, 611 and 613 Sansom Street, Philadelphia.
- Woglom & Miller.**—Sole Agents for the "Prime" Thimbles in Gold and Silver, manufactured by Ezra C. Prime. 34 John Street, N. Y.

**Trunks.**

**Crouch & Fitzgerald**—Manufacturers of Trunks and Articles for Travelers' use. 1 Cortlandt St., 556 Broadway, and 723 Sixth Ave., N. Y.

**Watch Companies.**

- American Watch Co.**—Robbins & Appleton, No. 5 Bond Street, N. Y.
- Illinois Watch Co.**—Springfield, Illinois. 21 Maiden Lane, N. Y. and 71 Washington Street, Chicago, Ills.
- The E. Howard Watch and Clock Co.**—Cor. Maiden Lane and Nassau Street, N. Y.
- Waterbury Watch Co.**—Manufacturers of the Waterbury Watch. Factory, Waterbury. Office, 52 Maiden Lane, N. Y.

**Watch and Chronometer Jeweler.**

- Queen, James.**—Watch and Chronometer Jeweler and Pallet Maker, 78 Nassau Street, room 8. Pivots inserted in Pinions, Balance, Staffs, etc.
- Robert, Henry L.**—Practical Chronometer and Watch Jeweler and Adjuster. 71 Nassau Street. Pallet and Hole Jewels for Chronometer Watches done in the best manner.
- Wennstrom, John.**—Watch, Chronometer and Clock Jeweling, Jewel Gauges, Ruby and Sapphire Draw Plates; Diamond Charged Polishing Stones for Jewel Settings; Pivots inserted in Pinions. 2 Dutch Street, N. Y.

**Watch Importers, Etc.**

- Abry, Chas. Leo**—Importer and Manufacturer of Swiss Watches of all grades. 63 Nassau Street.
- Aikin, Lambert & Co.**—Importers of Watches. Sole Agents for Paul Breton & Chas. Latour, Geneva. A general line of reliable Swiss Watches, Watch Cases, etc. 23 Maiden Lane, N. Y.
- Bartens & Rice**—20 John Street, Importers of Watches and sole agents in the United States for the celebrated Nicole, Nielsen & Co. Watches.
- Cross & Beguelin.**—Importers of Watches, Watch Tools and Materials, dealers in American Watches, No. 21 Maiden Lane, N. Y.
- Droz, Henry E.**—Importer of Watches, and Watch Case Manufacturer, Agent for the "E. Perregaux" Watch, and jobber in American Watches No. 92 Fulton Street, N. Y.
- Freund Max & Co.**—Importers of Watches, Jewelry and Precious Stones, 8 Maiden Lane, N. Y.

**Gagnebin, Chas.**—Importer of all kinds of Swiss, and Dealer in American Watches. 4 Maiden Lane, N. Y. Agent for Ulysse Breting's Fine Chronometers, Chronographs, Anchors, &c.

**Gallet, Julien.**—Importer of Watches. No. 1 Maiden Lane.

**Ginnel, Henry.**—Importer of Watches, Tools and Materials, 31 Maiden Lane, N. Y. P. O. Box 2967

**Hyde's Sons, John E.**—Wholesale Commission Agents, only for Jules Jurgensen, of Copenhagen; Jules Monard, of Geneva; and for other makers of all qualities of Watches, 22 Maiden Lane.

**Keller, L. H. & Co.**—Successors to G. A. Huguenin, Importers of Fine Watch and French Clock Materials, No. 64 Nassau Street, N. Y.

**Mathey Bros. & Mathez.**—Importers of Fine Watches and Sole Agents for the **H. L. Matile's** Watches. No. 16 Maiden Lane.

**Robert, J. Eugene.**—No. 30 Maiden Lane, New York. Agent for Louis Audemar's celebrated watches.

**Schumann, Chas. W.**—No. 24 John Street, New York. Importer of Fine Diamonds, Watches, etc. Sole Agent in the U. S. for the celebrated "Lange" Dresden Watch.

**Schwob, Adolphe.**—Manufacturer and Importer of Watches, 11 Maiden Lane, N. Y.

**Strasburger, Louis & Co.**—Importers and Makers of Watches of every description, 15 Maiden Lane.

#### Watch Cases.

**Dueber Watch Case Mfg Co.**—Manufacturers of Gold and Silver Watch Cases. Bryant Building, N. Y. Factory, Newport, Ky.

**Fahys, Joseph.**—Manufacturer of Watch Cases and Dealer in American Movements, 38 Maiden Lane.

**Glatz, Chas.**—Manufacturer of Silver Watch Cases. Bryant Building, cor. Nassau and Liberty Sts.

**Keller & Untermeyer.**—Manufacturers of Watch Cases with Raised Gold Ornaments. 9 Maiden Lane, N. Y.

**Ladd Watch Case Co.**—Manufacturers of the Ladd Patent Stiffened Gold Watch Cases, etc., 11 Maiden Lane, N. Y. Factory, 58 Eddy Street, Providence, R. I.

**Martins & Tissot.**—Manufacturers of Gold Watch Cases. No. 15 Maiden Lane, N. Y.

**The Brooklyn Watch Case Co.**—Manufacturers of the celebrated Eagle Case. 40 Maiden Lane.

**Willem Watch Case Co.**—Makers of Gold Watch Cases. Raised Gold Ornamentation and Jurgensen style of Engine Turning. 109 Sands Street, Brooklyn, N. Y. 16 Maiden Lane, N. Y.

#### Watch and Chronometer Repairers.

**Cerf, B.**—Practical Watchmaker and Repairer, No. 10 John Street, N. Y. Repairing and adjusting of Fine Watches done for the trade. All kinds of escape and stem-winding wheels cut to order.

**Goepf, Frederick A.**—Practical Watchmaker. Repairing of every description for the Trade. 25 Maiden Lane, N. Y. In office of H. Garland, Engraver.

**Heinrich, H. H. & Co.**—Sole Manufacturers of H. H. Heinrich's Patent Auxiliary Balance, and Adjusters and Repairers of Fine Watches and Chronometers. 18 John Street, N. Y.

**La Croix, J. H.**—(Late with Benedict's Time,) Watch and Clock Maker, 21 John Street, N. Y. Clocks of every description Repaired for the Trade.

**Lesperance, Theo.**—Watchmaker and Wheel Cutter. No. 1 Maiden Lane, New York. With Julien Gallet.

#### Watch Case Repairers.

**Feinier, Joseph A.**—Watch Case Maker and General Repairer. Specialty in fine Gold and Silver Cases. Jobbing promptly attended to. Nos. 4 and 6 John St., N. Y.

**Perret & Jardon.**—Watch Case and Spring Repairers. No. 80 Nassau St. (top floor), N. Y. Cases and Springs of all kinds neatly repaired.

**Tarbox, Hiram.**—Watch Case Repairing, Springing, Polishing and Engine Turning. 1874 North Fourth Avenue, bet. 176th and 177th Sts., N. Y. Express Packages should be sent to 92 Fulton Street.

#### Watch Glasses, Shades, Etc.

**Brown, Edwin H.**—No. 85 Nassau Street, Imported and Own Manufacture Watch Glasses, Flat, Flat Concave, Concave, Convex and fine Genevas. Fine fitting solicited.

#### Watches, Diamonds and Jewelry.

**Alford, C. G. & Co.**—Manufacturers. General line fine and Reliable Goods. Specialties in Onyx Goods and Chain. 200 Broadway, New York.

**Cohn, J. J.**—Importer and Manufacturer of Whitby Jet, Rubber and Pearl goods. Gold and Rolled-plate Jewelry, etc. 12 Maiden Lane, New York.

**Durfey & Reynolds.**—Successors to Durfey & Shiebler, Watches, Diamonds, Jewelry. No. 9 John Street, (up-stairs) New York.

**Friedman, Saml.**—Wholesale Dealer in Watches and Jewelry, 42 Maiden Lane, N. Y.

**Goddard, John M.**—Manufacturing Jeweler, — Seal Rings and Fine Locketts a specialty, No. 3 Maiden Lane, N. Y.

**Greason J. R. & Co.**—Successors to Arthur, Rumrill & Co., 182 Broadway. Manufacturers of Fine Jewelry and Gold Chains, also Diamond Mountings.

**Haskell, H. C.**—Manufacturing Jeweler. Seal Rings a specialty. Special attention to Jobbing of every description. 12 John street.

**Herzog, Louis & Co.**—Importers of Watches, Dealers in Diamonds and Jewelry, 52 Maiden Lane, N. Y.

**Hirsch Bros.**—Dealers in Watches and Diamonds and Manufacturers of Jewelry, No. 23 Maiden Lane, N. Y.

**Jandorf, P. & Bro.**—Importers of Watches and Jewelry, 196 Broadway.

**Kennedy, Frank S.**—Manufacturer and Wholesale Dealer in Jewelry and Gold and Silver Thimbles. No. 13 Maiden Lane, New York.

**Lissauer & Sondheim.**—Wholesale Jewelers and Jobbers in American Watches, No. 12 Maiden Lane, N. Y.

**Marx, Kossuth & Co.**—Importers of Watches and Dealers in Jewelry. 39 Maiden Lane, N. Y.

**May, Henry.**—Importer and Wholesale Dealer in Watches and Diamonds, and Manufacturing Jeweler. 19 John St., N. Y.

**Mayer, B.**—Manufacturer of Fine Jewelry, and Dealer in Watches, 71 Nassau street, cor. John street, New York.

**Myers, S. F. & Co.**—Manufacturing and Wholesale Jewelers—all grades. Importers of Watches. Illustrated Catalogue to the trade. 179 Broadway, N. Y.

**Oppenheimer Bros. & Veith.**—Dealers in Watches and Diamonds, and Manufacturing Jewelers, No. 35 Maiden Lane.

**Scott, J. T. & Co.**—Importers of Watches, and Manufacturers of Jewelry, and Jobbers of all Grades of American Watches, 4 Maiden Lane.

**Smith & Knapp.**—Wholesale Dealers in American and Swiss Watches, Diamonds, Gold and Plated Jewelry and Gold Chain. 182 Broadway, N. Y.

**Steele, J. W.**—Successor to Brainerd, Steele & Co., Manufacturer of Fine Jewelry and Brainerd's Patent Locketts. No. 9 Maiden Lane, N. Y.

**Stern Brothers & Co.**—Importers of Swiss Watches and wholesale dealers in American Watches, &c., 39 Maiden Lane.

**Stern & Stern.**—Dealers in Watches, Jewelry and Diamonds. No. 6 Maiden Lane, N. Y.

**Stites, D. H. & Son.**—Manufacturers of Fine Jewelry, Rolled Plated Goods and Chains, Parisian Diamond Rings, Studs and Earrings a specialty. 41 Maiden Lane, N. Y.

**Strauss, Jacob.**—Full Line of Gold and Plated Jewelry, and Importer of Watches. 18 John Street, New York.

**Thrall, E. A.**—Wholesale Dealer in Watches and Jewelry. No. 1 Maiden Lane, N. Y.

**Trier Bros.**—Importers of Garnet, Whitby Jet and Amber Jewelry, Silk Guards, Opera, Field and Marine Glasses, Pearl Card Cases. Also a full line of Gold and Plated Jewelry. 15 Maiden Lane, N. Y.

**Wheeler, Parsons & Hays.**—Manufacturers of Fine Jewelry, Watch Cases, Gold Chains, &c. and Dealer in American and Swiss Watches, No. 2 Maiden Lane, N. Y.

**White, N. H.**—Jobber in American-Waltham Watches and Chronographs. Waltham make of 10-k., 14-k. and 18-k. Gold and Sterling Silver Cases; Filled Gold Cases. 11 Maiden Lane.

#### Watch Tools, etc.

**Keller, L. H. & Co.**—Importers of Watchmakers' and Jewelers' Tools, Materials, etc. 64 Nassau Street, N. Y.

**Zimmern, Henry.**—Importer of Watch Materials, Tools, and Optical Goods, No. 8 Maiden Lane, (first floor.) Sole Agent for A. Huguenin & Gravier. Mainsprings, New York.

#### PHILADELPHIA

**Bennett, Jacob & Son.**—Diamond Setters and Manufacturing Jewelers, 925 Chestnut St.

**Bernard & Co.**—Manufacturers of Fine Roman and Etruscan Jewelry. Designs of every description made to order, 123 & 125 South Eleventh Street, Philadelphia.

**Booz & Co.**—Makers of Fine Gold Watch Cases and Plain Gold Rings, also Dealers in all American Movements, Diamonds, Jewelry, etc. 108 South 8th Street, Philadelphia.

**Conover David F. & Co.**—American Watches, Wholesale Salesroom, Southeast corner 7th and Chestnut Streets, Philadelphia.

**Herold, Chas P.**—Successor to Hildebrandt, Herold & Co., Manufacturing Jeweler and Diamond Setter. Diamonds. 916 Chestnut Street.

**Krieder, Peter L.**—Manufacturer of Sterling Silver Ware. 618 Chestnut Street, Philadelphia.

**McCall & Newman.**—Manufacturing Jewelers. Makers of the Original Gold Crown Filled Rings. No. 625 Arch St., Philadelphia.

**Morgan & Headly.**—Manufacturing Jewelers. Cameo Sets, Gold Sets, Roman Locketts, Rings, Coral Sets and a general line of rich goods. Corner 10th and Chestnut Streets, Philadelphia.

**Muhr's, H., Sons.**—Manufacturing Jewelers. Solid Gold and Filled Rings a specialty. 633 and 635 Chestnut Street, Philadelphia. 1 1/2 Maiden Lane, New York.

**Peters, Reese S.**—Manufacturer of Patent Rolled Plate or Filled Watch Cases, Dealer in American Movements, 308 Chestnut Street, Philadelphia.

**Rosenthal, G. F. C.**—Manufacturing Jeweler and Diamond Setter. Engraving and Designing of Monograms a specialty. No. 917 Sansom Street.

**Scherr, L. A. & Co.**—Wholesale Dealers in Watches Silver-Plated Ware, Spectacles, Fancy Goods, Watch Materials, etc. 726 Chestnut Street.

**Sheafer, W. H. & Co.**—Manufacturing Jewelers. Specialty: Band Bracelets. Factory, 612 and 614 Chestnut street, Philadelphia. Office, 15 John street, New York.

**Simons, Brother & Co.**—Manufacturers of Fine Jewelry, Canes, Thimbles, Chains. 611 and 613 Sansom Street.

#### CHICAGO.

**American Watch Company.**—of Waltham, Mass. No. 102 State Street, Chicago.

**Clapp & Davies.**—Wholesale Jewelers, 63 and 65 Washington Street. Catalogue and price list issued to watchmakers and jewelers.

**Dennison Manufacturing Co.**—Manufacturers of Jewelers' Paper Boxes, Morocco Cases, Tags, Cards, Pink and White Cotton, Tissue Papers, Sealing Wax, &c., &c., 102 Madison St., Chicago. Boston, New York, St. Louis, and Philadelphia.

**Gilbert, Wm. L., Clock Co.**—Manufacturers of Clocks, Regulators, and Time Pieces, and Clock Material of every description, 54 and 56 Madison Street, Chicago.

**Giles, Bro. & Co.**—Manufacturers and Jobbers in Watches, all classes of Jewelry, Materials, Clocks, Silver Ware, &c. Illustrated catalogues furnished to dealers on application. 101 & 103 State St.

#### NEWARK.

**Baker & Co.**—Gold, Silver and Platinum Refiners, Assayers and Sweep Smelters. 408 New Jersey Railroad Avenue, cor. Murray St., Newark, N. J.

**Diefenthaler Bros. & O'Donnell.**—Manufacturers of Fine Jewelry, Lace Pins, Ear Rings and Patent Spring Bangles a Specialty. 36 Crawford Street, Newark, N. J.

**English & Miller**—Manufacturers of Gold Jewelry, Diamond and Fancy Stone Rings, Roman Locketts, Bangle and Flexible Bracelets, Knife Edge Lace Pins and Sets, Scarf Pins and Link Buttons. 61 and 63 Hamilton St., Newark.

**Felger, F. & F.**—Manufacturing Jewelers. Specialties:—Roman Band Bracelets, Lace Pins, Scarf Pins, Ball and Fancy Ear Rings. No. 477 Washington Street, Newark, N. J.

**Fiedler, Herrman**—Successor to Kurze & Fiedler, Engraver, Die Sinker and Press Tool Maker, 363 Market Street, Opposite Pennsylvania R. R. Depot, Newark, N. J.

**Glorieux, W. L.**—Assayer, Refiner and Sweep Smelter. 13 and 15 Franklin Street, Newark, N. J.

**Hopper & Wilson**—Manufacturers of Fine Jewelry, No. 8 Maple Place, Rear 44 Green St., Newark, N. J.

**Huger & Heitlinger**—Manufacturers to the Jobbing Trade only. Makers of Roman, Stone, Engraved and Enameled Locketts a specialty. Also Sleeve Buttons, Collar Buttons and Studs. 477 Washington Street, Newark, N. J.

**Krippendorf, C. & Schuller, F.**—Machinists and Jewelers' Tool Makers. 19 Greene Street, Newark, N. J. Rolls, Dies, Cutters, and Drawplates of every Description made and repaired.

**Lelong, L. & Bro.**—Gold and Silver Refiners. Assayers and Sweep Smelters, Southwest corner of Halsey and Marshall Streets, Newark, N. J.

**Milne, Alex.**—Manufacturer of Stem-winding Watch Crowns. 19 Ward Street.

**Neslor & Co.**—Manufacturers of 18 Kt. Gold Filled Hoop Ear Rings, Plain, Facet and Engraved, all sizes. 36 Crawford St., Newark, N. J.

**Regad, E. D.**—Lapidary. Specialty—Sardonyx, Black Onyx and Agates. 14 Oliver St., Newark.

### PROVIDENCE

**Arnold & Webster**—Manufacturers of Solid Gold Engraved Band Rings for the Jobbing Trade. 29 Point Street, Providence, R. I.

**Butts, Geo. F.**—Manufacturing Jeweler. Ladies' and Misses' Solid Gold Drops and Studs a Specialty. 119 Orange Street, Providence, R. I.

**Bradley, R. & Son**—Manufacturers of Solid Gold and Rolled Plate Jewelry. White Stone Goods a Specialty. 227 Eddy Street, Providence, R. I.

**Capron & Co.**—Manufacturers of Jewelry. Engraved Box Bracelets, Bangle Wire Bracelets, Original Lever Collar and Cuff Button. No. 407 Pine Street, Providence, R. I.

**Elmwood Paper Box Co.**—Makers of Jewelers' Cases, Trays, etc. Factory, 54 Greenwich St., Providence, R. I.

**Hamilton, William & Co.**—Manufacturers of Fine Rolled Plated Chains and Patent Band Bracelets. 116 Pine St., Providence, R. I.

**Harring'on, J. C.**—Maker of Fine Gold Plated Jewelry. Specialties:—Oval Wire Bangles, Band Bracelets and the Victor Swivel. 129 Eddy St., Providence, R. I.

**Hough, W. S., Jr., & Co.**—Manufacturers of the Hough, Jr., Rolled Plate Locketts, Charms and Pendants. For sale by all first-class Jobbers or Wholesale Jewelers in the United States and Canadas.

**Hutchison & Huestis**—Makers of Solid Gold Rings. Quality guaranteed. For the Jobbing Trade only. 185 Eddy Street, Providence, R. I.

**Irons, Chas. F.**—Manufacturer of Solid Gold Jewelry. Specialty, Emblems, Pins and Charms, Masonic, Odd Fellows, etc. 102 Friendship St.

**Pitts & Hicks**—Manufacturers of the Excelsior Button and Eclipse Lever Button, also a line of White Stone Gold Goods and a fine line of Lace Pins and Drops in Rolled Plate Goods. 120 Dorrance Street, Providence, R. I.

**Taylor, Geo. H. & Co.**—Watchmakers and Wholesale Dealers in Watches, Clocks, Watch and Clock Material, Tools, Spectacles, Eye Glasses, &c. Particular attention given to trade work. 136 Westminster Street (Room 1), Providence, R. I.

### PAWTUCKET.

**Fuller, Geo. H. & Son**—Jewelers' Findings, Gold, Silver, Gold Plated and Fire Gilt. Pin Stems, Joints, Catches, Split Rings, Chain Hooks and Swivels, Ear Wires, Chain Bars, etc. 99 Exchange Street, Pawtucket, R. I.

### CINCINNATI.

**Holland, John**—Manufacturer of Gold Pens, Pencils and Pencil Cases, Gold Toothpicks, etc. Nos. 19 and 21 W. 4th St., Cincinnati, Ohio.

### BOSTON.

**Boston Watch Case Co.**, makers of Watch Cases. Especial attention given to Repairing. 1, 3 & 5 Province Court, Boston, Mass.

**Boyce, E. J.**—Manufacturer of Solid Gold Jewelry. Rings a Specialty. 383 Washington St., Boston, Mass.

**Weber, H. & Co.**—Wholesale Jewelers, Importers and Jobbers of Fine Watch Materials, Jewelers' Findings, Tools, etc., Optical Goods and Silk Guards. Agents for Whitcomb, Standard and Stark's Lathes. 424 Washington St., Boston, Mass.

### BUFFALO.

**Oliver, W. W.**—Manufacturer of Hand and Power Rolling Mills for Jewelers and Silversmiths, 39 Clinton Street, Buffalo, N. Y.

### CLEVELAND.

**Chandler, J. M. & Co.**—Manufacturers of the Patent Embossed Bracelet and Jobbers in all kinds of Clocks, Watches, Jewelry, Tools, Materials, etc. 185 Superior St., Cleveland, O.

### LANCASTER.

**Bowman & Musser**—Jobbers in Watches, Clocks, Chains, Fine Tools and Materials. 20 East Chestnut Street, Lancaster, Pa.

### PITTSBURGH.

**Goddard, Hill & Co.**—Wholesale Dealers in American Watches, Jewelry, Silverware, Clocks, Materials, &c., 43 Fifth Avenue, Pittsburgh, Pa.

**Hodge, Slemmons & Co.**—Wholesale Dealers in American and Swiss Watches, Diamonds, Gold and Plated Jewelry, Clock Material, etc. No. 77 Fifth Ave., Pittsburg.

### NEW BEDFORD.

**Nye, W. F.**—Manufacturer of Watch, Clock and Chronometer Oils, New Bedford, Mass.

**Wheeler, G. B.**—Manufacturer of Watch and Chronometer Oils, New Bedford, Mass.

### WORCESTER.

**Washburn & Moen Manufacturing Co.**—Makers of Fine Watch Mainsprings, Worcester, Mass. 16 Cliff Street, New York. 107 to 109 Lake Street, Chicago, Ill.

### WINCHESTER.

**Goodell & Winn**—Manufacturers of American Watch Hands, Winchester, Mass.

### ALBANY.

**Reiss, Chas.**—31 and 33 So. Pearl Street, Albany, N. Y. Importer of Watch Tools and Material; General Supply; Low Prices. Repairing for the Trade.

### CANADA.

**Ellis, P. W. & Co.**, No. 31 King street, East Toronto, Ontario, Manufacturing Jewelers, Watchmakers, importers and Jobbers of Watchmakers, and Jewelers' Tools, Materials, General Supplies and American Jewelry. Correspondence solicited with manufacturers of Novelties or specialties in American Tools and Jewelry.

GEO. W. DUBOIS.

F. N. NAUMAN.

## GEO. W. DUBOIS & CO.,

IMPORTERS OF

## Watches & Optical Goods.

ALL STYLES AND QUALITIES OF

SPECTACLES AND EYE-GLASSES.

Longines' Watches and Movements,

The Watches in Gold, Silver and Nickel Cases of New and Handsome Patterns. The Movements fit 18 size Waltham Stem Winding Hunting Cases.

36 Maiden Lane, New York.

ORDERS BY MAIL RECEIVE PROMPT ATTENTION.

## BARNES' No. 4 LATHE, For the Heavier Work of Jewelers.

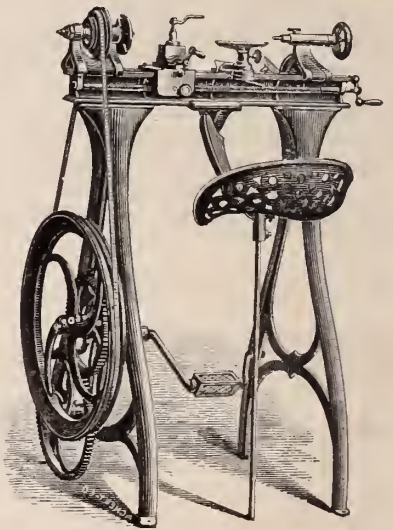

Barnes' Patent Foot and Steam Power Machinery. Complete outfits for Actual Workshop Business. Lathes for wood or metal. Circular Saws, Scroll Saws, Formers, Mortisers, Tenoners, etc., etc. Machines on trial if desired. Descriptive Catalogue and Price List Free.

W. F. & JOHN BARNES,  
2088 Main Street, ROCKFORD, ILL.

## EXCELSIOR'S

Practical Treatise

ON THE

## BALANCE SPRING

Including Making and Fitting Hair Springs, Regulating, etc.

Also containing the Adjustment of Watches and Chronometers for Isochronism, Position, Heat and Cold and Rate.

PRICE, \$3.50.

D. H. HOPKINSON,  
42 Nassau Street, New York.



**E. J. BOYCE,**

(Formerly Boyce & Wainwright.)

⇒ **MANUFACTURING JEWELER** ⇐

**SOLID GOLD RINGS A SPECIALTY.**

My **BAND RING** Specialties, for **PRICE, QUALITY** and **FINISH**, are not equaled by any in the Trade,

**383 WASHINGTON ST.,  
BOSTON, MASS.**

**S. DAVIDSON,**

IMPORTER OF

**DIAMONDS & WATCHES,**

MANUFACTURER OF

**DIAMOND JEWELRY,**

**No. 9 JOHN STREET,  
NEW YORK.**

Goods sent on selection to any part of the United States upon satisfactory reference.

Solid Gold Rings a Specialty.

**WM. H. ELY,**

**SOLID GOLD RINGS,**

MANUFACTURER.

Viz., Plain, Chased, Engraved, Enameled, Engine Turned, Shield and Scale. All qualities guaranteed. Orders Promptly Executed.

58 Nassau Street, New York.

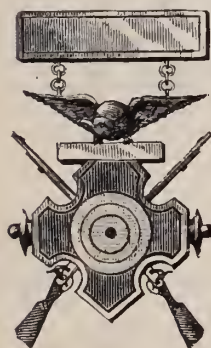

**C. B. WILKINSON,**  
Manufacturing Jeweler,

8 JOHN ST., N. Y.

Medals, Badges and Masonic Jewelry  
**A SPECIALTY.**

Designs furnished free upon application.

**H. WUNDOEHL,**

**GOLD & SILVER REFINER,**

Assayer and Sweep Smelter,

**21 JOHN ST.,**

Bet. Broadway & Nassau St., **NEW YORK.**

The highest price paid for Gold, Silver and Platinum.  
*Fine Gold, Silver and Copper always on hand.*

**Washburn & Moen M'fg. Co.,**

**WORCESTER, MASS.**

Manufacturers of Fine Watch Mainsprings for American, Swiss and English Watches, which, for Toughness, Elasticity and Finish, are Unequaled.

N. Y. Warehouse: Chicago Warehouse:  
**16 Cliff Street. 107 to 109 Lake St.**



**J. J. COHN,**

IMPORTER OF

↳ **WHITBY JET** ⌞

MANUFACTURER OF

**Gold & Rolled Plate Jewelry,**

Bracelets, Charms & Locketts a Specialty.

**12 MAIDEN LANE, N. Y.**

Goods Sent on Selection if Satisfactory References are Given.

**WM. SCHWENCKE,**

Manufacturing & Jobbing Jeweler,

**43 MAIDEN LANE, N. Y.**

Gives particular attention to the Repairing and Jobbing Department of the Jewelry Business. Prompt Attention, Moderate Prices and First-Class Workmanship Guaranteed to all. Country Orders Promptly attended to.

Also Proprietor of **Schwencke's Solution** for preserving the color of gold when passing through the fire. Superior to all others. **25c. a Bottle.**

**H. WASELL,**

**RUBBER STAMPS,  
BRASS STAMPS,  
Brushes, Inks, &c.**

Stencil Plates,



Burning Brands,

**SEALS & PRESSES,**

**No. 7 North William St.**

First house South of East River Bridge, N. Y.

**FINE STEEL STAMPS A SPECIALTY.**

**J. WIENHOLD,**

Manufacturer of Fine Jewelry.

**DIAMOND MOUNTINGS**

**A SPECIALTY.**

24 JOHN ST., N. Y. CITY.

**HIBBARD G. GILL,**

GOLD AND SILVER

**Watch Case Manufacturer,**

Dealer in Watches,

American Watch Movements Always on Hand.

**618 Chestnut Street,**

Fifth Floor.

PHILADELPHIA.

**HENRY TROEMNER,**

**710 Market Street,**

PHILADELPHIA.

Manufacturer of Fine Gold Scales,

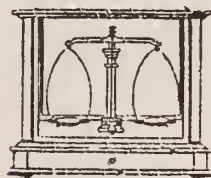

**DIAMOND SCALES,**

Bullion Balances and Weights, in use at all the U. S. Mints and Assay Offices.

PRICED CATALOGUE ON APPLICATION.

**JNO. F. LUTHER,**

MANUFACTURER OF



Masonic Jewelry.

**79 Nassau Street, N. Y.**

Illustrated Catalogue sent on application

ADOPTED AND IN USE BY  
**RANDEL, BAREMORE & BILLINGS,**  
 58 Nassau Street, N. Y.

THE TRADE SUPPLIED.  
 Descriptive Circulars furnished  
 on Application to  
**George W. Washburn, Patentee,**  
 58 NASSAU ST.,  
 NEW YORK

**SAFETY**  
**EAR FASTENING,**  
 Pat. May 10, '81—Oct. 11, '81.

**Jointed**  
**EAR WIRE**  
 AND  
**BAR BETWEEN CRAMPS**  
**OF SETTINGS.**  
 Patented March 1, 1881.

**TELESCOPIC**  
**SAFETY PIN CATCHER,**  
 Pat. Sep. 20, '81—Jan. 10, '82.



**IMPORTANT TO THE TRADE!**

ESTABLISHED 1869.

**CHARLES REISS,**  
 Watch and Chronometer Maker.

Repairing for the Trade only. Send for Price List. Receive Jobs all over the U. S. by Mail or Express. Replace Broken Parts of Watches at Low Prices. Fine Repairing Establishment, and none but Experts employed.

**31 and 33 South Pearl Street,**  
**ALBANY, N. Y.**

**REUBEN HAINES,**  
**ANALYTICAL CHEMIST,**  
 NO. 738 SANSOM ST.,  
 PHILADELPHIA.

Laboratory for Assay and Analysis of  
 GOLD AND SILVER ORES, LEAD, COPPER,  
 ZINC, IRON, STEEL, COAL,  
 WATER ANALYSIS.

**C. KNAPP,**  
 Manufacturer of  
 Superior Band  
 and Children's  
 Stone & Fancy  
**RINGS**  
 And Enameled Goods,  
 41 Maiden Lane,  
**NEW YORK.**



**BURGESS'**  
 Patent Portable Mechanical  
**BLOW-PIPE,**  
 Supersedes the Forge, Bellows  
 and Mouth Blow-pipe, by sav-  
 ing time, labor, and breath,  
 giving the gentlest flame or hot-  
 test blast without exertion.  
 PRICE, - - \$10.00.  
**J. ELLIOTT SHAW,**  
 154 South 4th Street, Philadelphia.



**BUERK'S WATCHMAN'S TIME DETECTOR.**



Safety Lock Attachment Patented  
 April 25, '82.

Used by all large manufacturing  
 establishments, public buildings,  
 warehouses, etc., to control watch-  
 men. The simplest, strongest,  
 cheapest and most complete of its  
 kind made.

Price, with pouch, 400 paper dials,  
 record book, and 12 different keys  
 with chains for 12 different stations,

**COMPLETE, \$50.00.**  
**O. E. HAUSBURG,**  
**71 NASSAU ST., Room 3,**  
 P. O. Box 1239, **NEW YORK.**

**Watchmakers' Slide Rests**  
 A SPECIALTY.

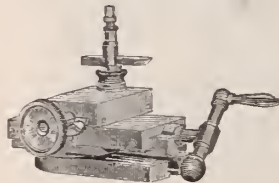

**TWO STYLES,**  
**PRICE,**  
**\$10.00 & \$16.00.**

Warranted as good as the best. Sent C. O. D. on approval  
 Write for Illustrated Circular to the Manufacturer

**R. H. FRAZEE,**  
**TOLEDO, IOWA.**

**EXCELSIOR'S**  
 Practical Treatise  
 ON THE  
**BALANCE SPRING**  
 Including Making and Fitting Hair Springs,  
 Regulating, etc.

Also containing the Adjustment of Watches  
 and Chronometers for Isochronism, Posi-  
 tions, Heat and Cold and Rate.

PRICE, \$3.50.

**D. H. HOPKINSON,**  
 42 Nassau Street, New York

**GEORGE UIBEL,**

MANUFACTURER OF

Sea Bean & Alligator Teeth

—\*JEWELRY\*—



142 Fulton St., N. Y.

Send for Catalogue and Price List.

ESTABLISHED 1873

**CHAS. P. HEROLD**  
 MANUFACTURER JEWELER  
**DIAMONDS**  
 916 CHESTNUT STREET UP STAIRS  
**PHILADELPHIA**



ESTABLISHED 1869.

The

Jewelers'

Circular

AND

Horological Review.

THE RECOGNIZED ORGAN  
 OF THE TRADE.

Subscription \$2.00 per Annum.

D. H. HOPKINSON,

Editor and Proprietor,

42 NASSAU STREET,

New York.



**EUREKA**  
PAT. OVAL SPLIT RINGS.

WM. M. FISHER & CO.,  
MANUFACTURERS OF  
**Gold & Silver Chains**  
AND  
**CHAIN TRIMMINGS,**  
Factory, 226 EDDY ST., PROVIDENCE, R. I.,  
Where all correspondence should be addressed.  
NEW YORK OFFICE, No. 13 JOHN STREET.

**EUREKA.**

We beg to call your attention to our new  
**Eureka Oval Split Rings,**  
Better Shape, More Easily Adjusted and Warranted  
**To Stand Fifty Per Cent.**  
*More Strain than Round Ones  
of same Size and Weight.*  
FOR SALE BY ALL JOBBERS.  
\*SEND ALONG YOUR ORDERS\*



**REST FENNER SMITH & CO.**  
MANUFACTURERS OF  
**FINE GOLD & SILVER HEADED  
CANES**

701 BROADWAY  
N.Y.

SPECIAL FACILITIES FOR FURNISHING  
INDIVIDUAL IDEAS, SYMBOLS, GRAFTS  
OR PROFESSIONS.  
SEND FOR ILLUSTRATED CATALOGUE.



**KEY**  
Patented Jan. 25, 1881.

**TAG**  
Patented Jan. 25, 1881.

**A. N. CLARK**  
PLAINVILLE,  
CONN.,  
Manufacturer of

**Watch Case Springs, Watchmakers' & Jewelers' Bench Tools,  
CROSBY'S JEWELING TOOLS, &c.**



**STOP IMPORTING KEYS!**  
For Low Price Key Use the  
**New Style Loop Key.**

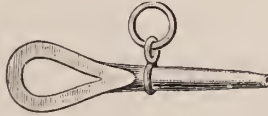

A plain Steel Key of good appearance, and excellent quality. It will not wear the pocket. It has a swivel, and is much better made than the imported plain steel or iron keys.

**PRICE PER CROSS, FINE NICKEL FINISH, \$2.25**  
Postage, 10 Cents Per Gross Additional.

This Key is good and cheap enough to become universal. Send business card for illustrated price list. Enclose three cent stamp for sample key.

SOLD BY JOBBERS IN WATCH MATERIALS AND NOTIONS.  
**A. N. CLARK, Plainville, Conn.**

**The Burbank Manufacturing Company**  
Manufacturers of **GOLD & SILVER**

**Thimbles,**  
GOLD SILVER, STEEL,  
RUBBER, And SHELL,

**BURBANKS PATENT.**  
**EYE GLASS**  
Self Adjusting.

**SPECTACLES AND EYE-GLASSES**



OF ALL DESCRIPTIONS.

**SOLID GOLD RINGS**  
**Office, 14 MAIDEN LANE. NEW YORK.**  
Manufactory, Springfield, Mass.

# Spencer Optical Manuf'g Co.

ARE NOW MAKING MANY

**NEW**

AND

**Desirable Styles**

FOR THE

**Early Spring Trade.**



*Indestructible Celluloid Spectacles,  
Our Gold Goods are Unsurpassed  
for Beauty, Durability  
and Finish.*

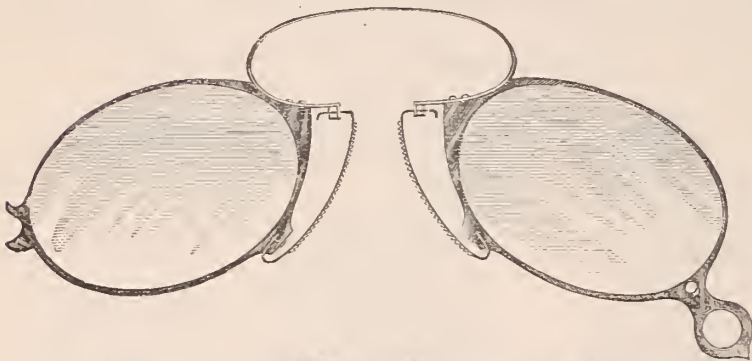

## CELLULOID SPECTACLES.

The very latest improvement, made in Shell and Amber Color; it has substantial advantages over all others, being strong, light and not subject to rust.

THE

## CELLULOID EYE-GLASS

has made its own reputation and is universally popular wherever introduced.

### BEWARE OF IMITATIONS.

We make a **SPECIALTY** in **SPECIAL GOODS** for the **FINE RETAIL TRADE**, which gives customers handling our goods **IMMENSE ADVANTAGE** over all others.

### QUALITY OF GOLD GUARANTEED.

We are importing large Invoices of Opera, Field and Marine Glasses in Staple and Novel Designs.

Catalogue sent on receipt of Business Card.

# Spencer Optical Manufacturing Co.,

13 MAIDEN LANE, NEW YORK.

Established 1853.

# L. H. KELLER & CO.

Successors to G. A. HUGUENIN,

IMPORTERS OF

WATCHMAKERS' and JEWELERS'

## TOOLS AND MATERIALS.

GENERAL AGENTS FOR

The Philadelphia Watch Company,

— AND —

American Watch Tool Co.,

MANUFACTURERS OF

## THE WHITCOMB LATHE.

SOLE AGENTS IN THE UNITED STATES FOR THE SALE OF

**LUTZ'S**

## CELEBRATED ROLL HARDENED HAIR SPRINGS, MOEBIUS OIL

For Chronometers, Watches, Clocks, Telegraph Instruments and all other delicate machinery. Made from Pure Refined Neatsfoot Oil, and Warranted to Excel anything in the market as a Lubricator. **SAMPLES GRATIS.**

### OUR OWN GRADUATED

AND JURGENSEN RECOILING MAINSPRINGS, pronounced by all experts Superior to all. Sold in Separate Strengths or Force.

Extra Fine Pinions cut from Solid Steel Wire. Gauged Hole Jewels of First-class Workmanship. A Full Line of Materials, for the PATEK, PHILIPPE & CO. GENEVA WATCHES, and all other Celebrated Makers.

### THE BOLEY LATHES AND TOOLS,

Celebrated for their Practical, Substantial and Workmanlike Construction, Superior Design and Finish.

*Our aim is to furnish nothing but First-class Serviceable Goods, especially manufactured for the Consumer, and not solely for the Market, like the cheap trash advertised in highly illustrated catalogues with which the country is flooded.*

**TREATISE ON MODERN HOROLOGY IN THEORY AND PRACTICE.** By M. CLAUDIUS SAUNIER, Ex-Director of the School of Horology at Macon, France; Knight of the Legion of Honor, etc.; Hon. Sec. to the Paris Society of Horologists. Translated from the French by JULIEN TRIPPLIN, Besançon Watch Manufacturer, and EDWARD RIGG, M. A., Assayer in the Royal Mint, London.

This Work comprises 832 large octavo pages, with 78 wood cuts and 21 colored double-page copper-plate engravings. Bound in half calf, with an appropriate and handsome ornament in gold on front cover.

**Price, \$15.00.**

**THE WATCHMAKER'S HAND BOOK.** By the same author and translators. Intended as a companion to the Treatise. Bound in cloth.

**PRICE, \$4.00.**

**64 Nassau Street,**

NEAR MAIDEN LANE,

**NEW YORK.**

L. H. KELLER,  
EDWARD HUNZIKER,  
F. J. BOESSE.

We do not publish Price Lists.

**SPECIAL NOTICES.**

**Notices under this heading, not to exceed Six Lines, \$1.00 each insertion.**

Advertisers having letters addressed in care of this office, must inclose postage for answers forwarded.

**WANTED.**—A first-class jeweler and engraver. Address, with references, J. P. Stevens & Co., Atlanta, Ga.

**WANTED.**—A salesman; must be an expert judge in diamonds; communications will be treated confidentially. Address Jewelers' Circular office.

**TRAVELING SALESMAN** open for engagement after the first of July; knows and has trade west to Utah; best of references. Address H. K., care of Circular.

**WANTED.**—A permanent position by a general jeweler, letter and monogram engraver, one who is accustomed to charge of job shop. Address H. H. A., care of Circular.

**A SALESMAN** of pleasant address is desirous of making an engagement with a manufacturer of silver plate goods, to travel south or west. Address Representative, care Jewelers' Circular.

**FOR SALE.**—A first-class jewelry store 20 miles from N. Y. city, is established and a good paying business. Reason on death of proprietor. Address Tell A. Beguelli, 71 Nassau Street, N. Y.

**WANTED.**—Situation by a practical watchmaker and jeweler. Have had 12 years' experience; speaks English and German; correspondence solicited. Address Watchmaker, 871 South High St., Columbus, Ohio.

**WANTED.**—A good watchmaker's lathe with fixtures, in exchange for a quarto job printing press (DeGENER make), complete, 16 fonts of type and 3 fonts of wood type, new. Address P. O. Box 384, Wallingford, Conn.

**FOR SALE.**—One-half interest in a first-class jewelry store in a city of 65,000 inhabitants; location best in the city; a rare chance for a man with cash to buy. Address F., care of Jewelers' Circular and Horological Review.

**WANTS.**—A young man desires a situation to work under instructions for about 6 months on watch work; has worked at the bench over 4 years and is a good jobber. Address Samuel King, P. O. Box 98, Harrisburg, Pa.

**MOSELEY & CO.**, Elgin, Ill., manufacturers of the "Moseley" Lathe, with full line of fixtures and attachments. Designed especially for the watchmaker and repairer. Combining accuracy, durability, convenience and style.

**WANTED.**—Situation by a young man of three years' experience at the bench and salesman, of good morals and strictly temperate; can give best of reference. Address Jos. C. Gibson, care of J. Irvin Bowers, Williamsport, Pa.

**WANTED.**—A partner in a well established jewelry business in a western city; must be an intelligent and practical young man. Capital required about \$5,000; best reference given and required. Address "Partner," care T. Kearney, 133 State St., Chicago, Ills.

**WATCHMAKERS AND JEWELERS.**—Do you ever burn or discolor coral, sea lufoid, or colored leaves on jewelry? buy Spickerman's blow pipe attachment, saves many times its cost to jeweler; fits any blow pipe. Price 35c. John Spickerman, Jefferson, N. Y.

**WANTED.**—Situation immediately by a fine and skillful watchmaker. Has one of the best sets of tools in the country, all nicked; accustomed to the fine work in city stores; first-class references; steady situation desired. Watchmaker, box 121, Minerva, Stark Co., O.

**FOR RENT.**—Desk and vault room in the Jewelers' Exchange Building, corner State and Washington streets, Chicago. Fire-proof building. Fire and burglar-proof vault. Suitable for manufacturing jewelers or importers office. Logau & Baro, 104 State St., Chicago.

**WANTED.**—About August 1st, a good watchmaker who is also a good salesman. A young man of good address preferred who is something of a musician. A long engagement; best of references required; nice town and nice store. Address J. R. Watts & Co., Ashland, Nebraska.

**GEORGE E. WILKINS**, manufacturer and importer of cutters for watchmakers' use, stem-winding cutters of all the different forms, rounding up cutters of the finest quality, also ratchet cutters. A large stock of second hand and new marine chronometers. No. 21 South Salina street, Syracuse, N. Y.

**FOR SALE.**—The leading jewelry store in a thriving town of 7,000 inhabitants; been established 40 years; doing a good business and room for a large increase; will sell for what stock will invoice; fixtures may be bought or rented; satisfactory reasons given for selling. Address R. H. Conlyn, Carlisle, Pa.

**A WATCHMAKER**, fully competent, wishes to change his present location about October 1st, 1884. Is 26 years of age and single, with 8 years' experience, has a complete set of tools, American lathe, etc. California or Texas preferred. Is at present with J. W. Forney, Steubenville, O. "Correspondence solicited.

**FOR SALE.**—First-class jewelry store in town of 8,000 population and thickly settled country around. Leading store of the place in stock and trade. Will invoice stock and fixtures about \$5,000. Reasons for selling are not a practical jeweler and want to move west. Address C. C., care Jewelers' Circular.

**A SITUATION** with a first-class watchmaker is open to a young man of good character who has had several years' experience in watch work and wishes to improve his knowledge of repairing. Applicant must furnish own tools. Address, stating ability and amount of wages expected, South, care Jewelers' Circular.

**FOR SALE.**—Stock, fixtures and tools of a profitable jewelry business. Fixtures and stock comparatively new, from \$5,000 to \$7,000, will reduce it to \$3,000. An old established business situated in a thriving southern town of 4,500 inhabitants. Satisfactory reasons for selling. This is a rare opportunity for a responsible man. Address W. B. P., care Jewelers' Circular.

**FOR SALE.**—Large Universal lathe (cord gear), very accurate and complete. Rounding up tool (cord gearing), cutters, &c. complete; both are Swiss make; 1 large lathe wheel brass boxing; 1 watchmaker's portable work bench (walnut), with veered trout, very nice and complete; been used one week only; must be sold to satisfy debt. Address, with stamp, Universal Lathe, care of this office.

**INTERESTING FOR MANUFACTURERS OF CHARMS.**—A patent right for sale. Or a capable man of honest and noble character with capital as partner wanted. For a quite new and useful charm which is patented in four countries. Already manufactured and sold in Germany with great success, and of no doubt it will make a great success in the United States. For further particulars, address Hohelsen's Patent Charm, care of Jewelers' Circular.

**TO THE TRADE.**—I make a specialty of supplying the Trade with stones for jobbing purposes. Parties having jewelry out of which the stones have been lost, sending their orders by mail or express, will have them promptly attended to. A large stock of cameos, pearls, turquoise, garnets, amethysts, doublets, foil backs, white and colored imitation stones on hand. All kinds of setting done for the Trade. W. Archibald, 73 Nassau street, New York.

**BUYERS' DIRECTORY.****NEW YORK.****Assayers and Sweep Smelters.**

**Wundoehl, H.**—Gold and Silver Refiner, Assayer and Sweep Smelter. 21 John Street, N. Y.

**Badges and Medals.**

**Stockwell & Newman**—19 John Street. Manufacturers of Badges, Medals and Presentation Pieces in Gold and Silver. Also Jewelry and Mounters of Diamonds. Designs supplied.

**Band Rings.**

**Knapp, Charles**, 41 Maiden Lane, N. Y. Specialty: Superior Band Rings, also Ring Shanks & Heads for Seal and Diamond Rings.

**Black Onyx Jewelry.**

**Cox & Sedgwick**—Manufacturers of Black Onyx Jewelry, No. 26 John St. New York.

**Lawson, Samuel**—No. 18 John Street. Manufacturer of Black Onyx Jewelry. Coral repaired for the trade. Goods sent on approval to responsible dealers.

**Woglom & Miller**—Manufacturers of (exclusively) Black Onyx Jewelry, 32 & 34 John St., N. Y.

**Blue Enameled Locketts.**

**Bissinger, Philip & Co.**—Importers of Diamonds, Pearls and Precious Stones. Agent for the Bohemian Garnet Goods. Blue Enameled Locketts, 22 John St., N. Y.

**Emrich, I.**—Importer of Blue Enameled Locketts, Ear Drops and all kinds of Enameled Jewelry; also Enamel for Manufacturing purposes. 66 Nassau St., N. Y.

**Hess & Schliesser**—Importers of Diamonds, Fine Jewelry and Novelties in French Goods. Specialties: Gold and Blue Enameled Locketts, Charms and Crosses. 2 John Street

**Bohemian Garnet Jewelry.**

**Bissinger, Philip & Co.**—Importers of Diamonds, Pearls and Precious Stones. Sole Agent for the Bohemian Garnet Jewelry. Blue Enameled Locketts. 22 John St.

**Emrich, I.**—Importer of Half Pearls and Bohemian Garnet Jewelry. Designs made to order in our European Factory at moderate prices. 66 Nassau St., N. Y.

**Clock Companies.**

**Ansonia Clock Co.**—Manufacturers of every description of Clocks. 11 to 21 Cliff street, New York.

**Kroeber, F.**—Manufacturer and Dealer in American and French Clocks, No. 14 Cortlandt Street.

**New Haven Clock Co.**—16 and 18 Park Place, N. Y.

**Seth Thomas Clock Co.**—20 Murray Street, N. Y.

**Waterbury Clock Co.**—M. Bailey, Treasurer, Manufs and Jobbers, No. 4 Cortland St., N. Y., and No. 197 State Street, Chicago.

**Welch, E. N., Manufacturing Co.**—Manufacturers of American Clocks. No. 6 Warren St.

**Wm. L. Gilbert Clock Co.**—No. 6 Murray Street, Manufacturers of Clocks. Factories, Winsted, Conn.

**Cameo Cutters, Etc.**

**Peiter, Theodore**—Cameo and Intaglio Engraver. Patentee of the Cameo-Intaglio. No. 3 Maiden Lane, New York.

**Charms & Cold Watch Keys.**

**Rupp & Held**—Manufacturing Jewelers, Charms and Gold Watch Keys, with French and English Ratchets, a specialty. 15 John St., N. Y.

**Crucibles.**

**Berge, J. & H.**—Established 1850. Importers of Sand Crucibles, Covers, Chemical Porcelain, Glassware, and Jewelers' and Assayers' Supplies. 95 John Street, N. Y.

**Cutlery.**

**Harrison Bros. & Howson**—Manufacturers of Fine Ivory and Pearl Table and Pocket Cutlery, Carvers in Cases; Nutpicks, Nutcrackers and goods suitable for the jewelry trade. 126 Chambers Street. W. C. Burkinshaw, Sole Agent.

**Diamond Brokers.**

**Anderson, Otis**—Diamond Merchant and Broker, always ready to pay cash for bargains in Diamonds and Precious Stones, 4 & 6 John Street, N. Y.

**Bernhardt, Richard**—Diamond Broker and Importer, 65 Nassau Street (Room 6), N. Y. Paris, 20, rue des Petites-écuries.

**Friend S. & Son**—Brokers and dealers in Diamonds 33 John Street, cor. Nassau St. New York.

**Herbert, R. J.**—Diamond Broker and Dealer. 26 Maiden Lane.

**Diamond Importers.**

**Bernhard, A. & Co.**—Importers of Diamonds and Manufacturers of First-class Diamond Jewelry, Diamond Settings for Manufacturing Jewelers. Catalogue of Designs for the Trade free of charge. No. 2 Maiden Lane, New York.

**Bissinger, Philip & Co.**—Importers of Diamonds, Pearls and Precious Stones. Agent for the Bohemian Garnet Goods. Blue Enameled Locketts. No. 22 John St., N. Y.

**Bruhl, D & M.**—Established in 1848. 14 Maiden Lane, N. Y.; 111 Broad Street, Providence, R. I.; 14 Rue Bleue, Paris.

**Brunswick, S. & Co.**—Importers of Diamonds, 17 Maiden Lane, New York. Paris, Rue Lafayette. Amsterdam, Damsstraat.

**Citroen, L. B., & Co.**—Diamonds. 21 John St., N. Y. Cutting Works, 57 & 61 Rapenburgerstraat, Amsterdam. House in Paris, 44 Rue Laffitte.

**Faulkenau, Oppenheimer & Co.**—Manufacturers. Diamonds and Diamond Jewelry. 40 Maiden Lane, N. Y.

**Fera, Henry**—Importer of Diamonds, and Manufacturer of Fine Diamond Jewelry. 4 & 6 John Street, New York. Amsterdam, Holland, 23 Loojersgracht.

**Fox, M. & Co.**—Importers of Diamonds, Rubies, Sapphires and Fancy Gems. No. 1 Maiden Lane, New York

**Hedges, Wm. S. & Co.**—Importers of Diamonds. No. 170 Broadway, corner Maiden Lane.

**Henle Brothers**—Importers of and Wholesale Dealers in Diamonds only. No. 16 Maiden Lane, N. Y. Paris, 20 Rue Laffitte.

**Kuhn, Doerflinger, & Co.**—Manufacturing Jewelers and Importers of Diamonds, 18 John street, New York

**Leberthon, L. M.**—Importer of Diamonds and Manufacturer of Fine Jewelry. 14 John Street, N. Y.

**Miller Bros.**—Importers of Diamonds and Manufacturers of Fine Diamond Jewelry and Mountings.

**Neresheimer, E. Aug. & Co.**—Importer of Diamonds. No. 21 Maiden Lane, New York.

**Randel, Baremore & Billings**—Importers of Diamonds, corner Maiden Lane and Nassau St.

**Saril, S.**—Importer of Diamonds, 182 Broadway, N. Y. Branch of Vve. H. A. Marchand & Frères, 47 Rue Le Peletier, Paris.

**Saunders & Ives.**—Importers of Diamonds and other Precious Stones. No. 26 Maiden Lane.

**Smith, Alfred H & Co.**—Importers of Diamonds, No. 182 Broadway.

**Tannenbaum, L. & Co.**—Importers of Diamonds and Precious Stones. Steam Lapidary Works. Oriental Stones Cut and Polished a specialty. 65 Nassau St., N. Y.

**Taylor & Brother.**—Importers of Diamonds and Diamond Jewelry. 860 Broadway.

**Wickham, D. H. & Co.**—Importer of Diamonds. No. 31 Holborn Viaduct, London, 24 Maiden Lane, New York.

**Wolff, G. A.**—Importer of Diamonds, Rubies, Sapphires, Pearls, and other Precious Stones, 65 Maiden Lane, New York. 12 Rue de Chateaudun, Paris.

#### Diamond Jewelry.

**Baldwin, Sexton & Peterson**—Importers of Diamonds and Manufacturers of Diamond Jewelry, 692 and 694 Broadway, N. Y.

**Bornemann, Louis.**—Importer of Diamonds and Manufacturer of Rich Diamond Jewelry, 19 John Street, New York.

**Chalumeau, D.**—Diamond Jeweler and Manufacturer of Mountings. Novelties and Artistic Jewelry. No. 3 Maiden Lane, New York.

**Goldsmith, Ingomar & Co.**—Manufacturers of Diamond Mountings and Diamond Jewelry, 61 Nassau Street, New York.

**Goldsmith & Co.**—Manufacturers of Fine Diamond Mountings and Diamond Jewelry. Lace Pins, Ear Rings and Kings a specialty. 49 Maiden Lane, N. Y.

**Hartje, G. & F.**—Manufacturers of Diamond and Fine Jewelry, 39 Union Square, N. Y.

**Haug, John**—Manufacturer of Fine Diamond Mountings, etc. No. 130 Fulton St., N. Y.

**Heller & Bardel.**—Manufacturers of Diamond and Pearl Jewelry, and Dealers in Diamonds, Pearls, &c. 13 John Street.

**Jeanne Brothers.**—Manufacturers of Diamond Mountings & Rich Jewelry. 1 Maiden Lane.

**Lacroix & Verpillier.**—Manufacturers of Fine Gold Jewelry. Diamonds a specialty. 173 Broadway, N. Y.

**Luthy, A. & Co.**—Manufacturers of Fine Diamond Mountings, Lace Pins, Ear Rings, Rings, Knife Edge Bracelets, Hair Ornaments, etc., a Specialty. 35 Ann Street, corner Nassau Street, N. Y.

**Mitchell, Noah**—Manufacturer of Diamond Jewelry and Diamond Mountings. 52 Maiden Lane, New York.

**Nissen, Ludwig & Co.**—Dealers in Diamonds and Diamond Jewelry. No. 51 Nassau Street, New York, near Maiden Lane.

**Rosswog, C. & Son**—Manufacturers of Rich Diamond Goods. Nos. 5 and 7 Maiden Lane, N. Y.

**Scheer, William**—Diamond Jeweler and Manufacturer of Mountings, Novelties in Artistic Jewelry, 859 Broadway, near 17th St., N. Y.

**Stern, Louis**—Manufacturing Jeweler. Diamond Mountings a Specialty. 8 & 10 John St., N. Y.

**Voelker, C. T.**—Manufacturer of 18-k. Diamond Mountings, Diamond Jewelry and Roller Chain Bracelets. 15 Maiden Lane, New York.

**Waterman & Lehmann.**—Manufacturing Jewelers and Dealers in Diamonds. Diamond Work, and Fine fancy Rings a specialty, any piece of single work made to order. 37 Maiden Lane, N. Y.

#### Diamond and Pearl Setter, &c.

**Danziger, H.**—Diamond and Pearl Setter, 116 Nassau Street, (Second Floor,) Room 6, N. Y.

#### Diamond Cutters.

**Levy, Herman.**—Importer, Cutter and Polisher of Diamonds. 105 Fulton Street, New York.

**Mendes, D. De S.**—Diamond Cutter and Polisher, 113 Nassau St., N. Y. Re-cutting, Repairing and Matching a Specialty.

**Ramsgate, Robert H.**—Diamond Cutter and Polisher; Matching and Repairing a specialty. 16 Maiden Lane, New York.

#### Dials, &c.

**New York Dial Co.**—Manufacturers of Fine Watch Dials. Henry Abbott, Agent, No. 4 Maiden Lane, N. Y.

#### Enameled Clock Dials and Figures.

**Caesar Bros.**—Manufacturers of Enameled Clock Dials, also letters and numbers for signs. 230 and 232 East 25th Street, New York.

#### Enamelers, Etc.

**Nutt, J. D.**—Enameler on Gold, Silver, and Copper. Linen finished Buttons and Studs. Enameling in colors. 32 and 34 John Street, New York.

**Orr, J. C.**—Enameler on Fine Jewelry. Enameled in Colors. Linen Finished Buttons and Studs. Band Bracelets. No. 75 Nassau Street, N. Y.

**Orr, William N.**—Enameler on Fine Jewelry. Masonic Jewels and Badges a specialty. Linen Finished Work. 79 Nassau Street, Room 18, New York.

#### Engravers—Stone Seal, Etc.

**Fackner, Edward**—Carver, Engraver and Chaser on Jewelry and Pencil Cases, lettering, &c., 19 John Street.

**Holland & Gosling**—Stone Seal Engravers. Precious Stones inlaid and encrusted with Diamonds. No. 176 Broadway, New York, (fifth floor per elevator). Cameos cut and repaired.

**Knapp, Chas.** Engraver, Die Sinker & Stamper for Jewelry purposes. Ring Shanks & superior Band rings, 41 Maiden Lane, N. Y.

**Park, Wm.**—The Stone Seal Engraver. Arms, Crests, Monograms, etc., engraved on precious stones, 26 John Street, New York.

**Weston, James F.**—Stone Seal Engraver and incruiter of Precious Stones. Coats of Arms, Masonic, Odd Fellows, and other devices engraved. 32 John Street.

#### Fancy Goods, Clocks, Bronzes, Etc.

**Hinrichs, C. F. A.**—Importer of Fancy Goods, Glassware, China, Clocks, Bronzes, etc. 31 Park Place.

**Le Boutillier & Co.**—Importers of Fancy Goods, Clocks, Bronzes, &c., 33 West 23d Street.

**Straus, L. & Sons**—Importers of Potteries, Faïences, Bisque Figures and Rich Fancy Goods especially adapted for the Jewelry Trade. 40, 42 and 44 Warren Street, New York.

**Taylor & Bro.**—Importers of French Clocks, Bronzes, etc. 676 Broadway, N. Y.

**Young, J. M. & Co.**—Importers of Fine Parian, Lava, and Bisque Statuary, Bohemian, German and English Fancy Goods, 37 & 39 Murray St., New York.

#### Gold and Silver Cane Heads.

**Cuppia, L. A.**—Importer of Filigree Jewelry and Manufacturer of Silver and Gold Cane Heads and Novelties in Silver and Gold Jewelry. 19 Union Square, N. Y.

**Simons, Bro. & Co.**—Manufacturers of Gold Headed Canes. 611 and 613 Sansom street, Philadelphia.

**Smith, Rest Fenner & Co.**—No. 701 Broadway, Makers of Fine Gold and Silver Headed Canes.

#### Gold and Silver Plating, Etc.

**Bantle, A.**—Gold, Silver and Electro-Plating, 130 Fulton and 89 Nassau Streets, cor. Fulton Street, (Room 36,) N. Y. Watch Case Polishing.

**Jeandheur, F. & Son.**—Gold and Silver Electro Platers & Fire Gilders, coloring Etruscan and Gold Jewelry a specialty. 125 Fulton St.

**Klees & Magrath**—Gold and Silver Electro-Platers. Coloring Etruscan and Gold Jewelry a Specialty. 89 Nassau Street, New York.

#### Gold Chains, Etc.

**Beck, J. & Son,** Manufacturers of Fine Gold Chains and Chain Bracelets, 10 Liberty Place, near Maiden Lane, N. Y.

**Carter, Sloan & Co.**—Manufacturers of Fine Gold Chain, 15 Maiden Lane, New York.

**Edge, W. C. & Co.**—Manufacturers of the Celebrated Woven Fabric Gold Chain, No. 15 John Street.

**Kaufmann Bros.**—Manufacturers of Gold Chains, and Chain Bracelets, 12 First Street; Factory, 331 and 333 Bowery, N. Y.

**Kohn, Alois & Co.**—Manufacturers of Gold Chains. 9 Maiden Lane, N. Y.

**Saxton, Smith & Co.**—Manufacturers of Fine Gold Chain, No. 14 John Street, N. Y.

**Schlag, Chas.**—(Late Nordt & Schlag), Manufacturer of Gold Chains, Chain Bracelets and Fine Jewelry. 177 Broadway, New York. All kinds of Jobbing promptly attended to.

**Smith, W. & Co.**—Manufacturers of Gold and Silver Chains, Jewelry, etc. No. 25 Maiden Lane, N. Y.

#### Gold Pens, Etc.

**Aikin, Lambert & Co.**—Manufacturers of Choice Gold Pens, Cases, Holders, Toothpicks, etc., 23 Maiden Lane, N. Y.

**Fairchild, Leroy C. & Co.**—No. 10 Maiden Lane, New York. Manufacturers of Gold Pens, Pencils, etc.

**Fairchild, Leroy W.**—Manufacturer of Gold Pens, Pencil Cases, Tooth Picks and Novelties in Charms. No. 18 John St., N. Y.

**Foley, John**—Manufacturer of Fine Gold Pens, Pencils and Charms. 2 Astor House, N. Y.

**Gerow, Joseph U.**—Manufacturer of Pencil and Pen Cases for the Jobbing Trade only. No. 44 State Street, (near South Ferry,) Brooklyn, N. Y.

**Hicks, W. S.**—Established 1848. Manufacturer of Fine Gold Pens, Pencil Cases, Tooth Picks, and Charm Novelties of every description. No. 20 Maiden Lane.

**Johnson, E. S. & Co.**—Manufacturers of Gold Pens, Pen Holders and Pencils. Cor. Maiden Lane and Nassau Street, New York.

**Smith, H. M. & Co.**—Manufacturers of Gold Pens and Holders, Tooth Picks, Pencils, etc. Sole Manufacturers of Sprague's Patent Gold Fountain Pen. Importers of Nickel and Silver Watches. 173 Broadway, New York.

#### Gold Rings.

**Barnet Bros.**—Manufacturers of Stone and Seal Rings, 15 John Street, New York. Factory, Newark, N. J.

**Bowden, J. B. & Co.**—Manufacturing Jeweler.—Solid Gold Rings a specialty, 1 Maiden Lane.

**Cable, Geo. W.**—Manufacturing Jeweler. Plain and Band Rings a Specialty. No. 52 Maiden Lane, N. Y.

**Dattelbaum & Friedman**—Manufacturers of Fine Cameo and Seal Rings, all kinds of Fancy Rings and Diamond Mountings. 10 Maiden Lane.

**Ely, W. H.**—Manufacturer of Solid Gold Rings of every description. No. 58 Nassau Street.

**Engelfried, Braun & Weidmann**—Manufacturing Jewelers, 123 Fulton Street corner Nassau, New York. Commercial Building, room 31. Rings a specialty.

**Henrich, R.**—No. 35 Maiden Lane, Manufacturer of Gold Rings; also Patentee and Manufacturer of the Celebrated Self-Sizing Ring

**Hutchison & Huestis**—Makers of Solid Gold Rings. Quality guaranteed. For the Jobbing Trade only. 196 Broadway, N. Y.

**Kroll, H.**—Manufacturing Jeweler. 78 Nassau Street, New York. Specialty: Solid Gold Stone Rings. All kinds of Fine Jewelry made to order, also Repairing for the Trade.

**Ostby & Barton**—Manufacturers of Plain and Engraved Solid Gold Band Rings. Office, 176 Broadway, N. Y. Factory, 80 Clifford Street, Providence, R. I.

**Peckham, Wm. H.**—Manufacturers of Solid Gold Seamless Rings, and Fancy Embossed Rings, Patent Spectacles, Jewelry, etc. No. 4 Liberty Place N. Y.

**Radler, K.**—Manufacturing Jeweler. Gold Rings and Locketts a specialty. No. 179 Broadway, New York.

**Sauter, L.**—No. 1 Maiden Lane, New York, Manufacturer of Stone Rings of every description, as Diamond, Cameo, Onyx Turquoise, etc., Scarf Pins, Scarf Rings, Studs and Buttons.

**Shafer & Douglass.**—Manufacturers of all kinds of Seal, Stone, Turquoise, and fancy rings. No. 7 Maiden Lane, N. Y.

**Thurner & Church**—Manufacturers of Fine Gold Rings. No. 9 Maiden Lane, N. Y.

#### Hair Jewelry.

**Moutoux, Wm. E. & Co.**—Manufacturers of Fine Hair Mountings in Gold. Grand catalogues for the trade. 81 Nassau St., Rooms 1 and 2. Finest work and lowest prices

**Sauter, L.**—Manufacturer of Fine Gold and Hair Jewelry and Device Work. Pattern Book sent on application. No. 1 Maiden Lane, N. Y.

**Schwencke O.**—Manufacturer of Fine Hair Jewelry Orders from the country promptly attended to. No. 43 Maiden Lane.

#### Jewelry Cases, Fancy Boxes, Etc.

**American Morocco Case Co.**—7 and 9 Bond St., N. Y., make a specialty of Rich Jewelry and Silverware Cases for the fine Retail Trade. Also Improved Trays for Watches, Rings, etc.

**Braun, Chr. E.**—Manufacturer of Fine Jewelry Boxes and Trays for Show Cases and Trunks. No. 62 Chatham Street, New York. Trays for Show Cases and Trunks a Specialty.

**Bricka, C. A. & Co.**—Manufacturers of Morocco Cases for Cutlery, Silverware, Jewelry, etc. Sample Cards and Rolls. Cases in Rosewood, Black Walnut, etc. 52 Nassau Street, New York.

**Dennison Mfg Co.**—Manufacturers of Morocco, Plush and Velvet Jewelry and Silverware cases. New York, Boston, Philadelphia, Chicago, Cincinnati and St. Louis.

**Haensler, Chas. C.**—Manufacturer of Fine Morocco Cases for Jewelry and Silverware. Toilet Boxes, etc. Trays for Show Cases and Windows. 14 John Street, New York.

**Hebbard & Brother**—Manufacturers of Jewelry and Silver Ware Cases, and Fancy Wood Chests for Tea Sets and Flat Ware. 860 Broadway, New York.

**Kohn, Solomon & Co.**—Manufacturers of Fine Morocco Cases for Jewelry, Watches, etc. 43 Maiden Lane, New York.

**Lauten, Edw. A. & Co.**—No. 4 Great Jones St., Manufacturers of Fine Velvet, Brocade, Plush and Morocco Boxes, Patent Ring, Ear Ring and Gent's Scarf Pin Trays, Patent Watch and Bracelet Blocks, Window Decorations, etc.

**New York Morocco Case Co.**—Cases for Jewelry, Watches, Silverware. Boxes and Trays for Jewelers' Travelers. Show Cases and Window Fittings. No. 69 Nassau Street, New York.

**Sauer & Schroeter**—Successors to Loehr & Koerner, Manufacturers of Morocco, Velvet, Satin, Jewelry, Watches and Silverware Cases, Jewel, Work Boxes, etc., Fancy Trays and Store Fittings to order. 96 Liberty St.

**Schwarz, N.**—Manufacturer of fine Cases for Jewelry and Silverware, 21 East 17th Street, New York.

**Welch & Miller**—169 Broadway. Manufacturers of fine Morocco, Velvet, Russia, Brocade and Plush Jewelry Cases. Trays of every description; Jeweler's Cotton and Twine.

**Wiggers & Froelick**—No. 60 Nassau street—Manufacturers of Cases for Jewelry, &c., of every description. Trays for Show-cases, Stands for Show-windows, etc.

#### Jewelers' Findings.

**Dennison Mfg Co.**—Paper Jewelry Boxes, cards, tags, pink and white cotton, etc. etc. New York, Boston, Chicago, Cincinnati, Philadelphia, St. Louis.

**Ettlinger, L., & Sons**—Makers of Cases and Paper Boxes of every description for Jewelers and Silversmiths. Fine Cases and Trays to order a specialty; also Cards, Tags, Cotton, Tissue Paper, &c. 80 Nassau St., N. Y.

**Valfer, S. & Co.**—Manufacturers and Dealers in Jewelers' Boxes, Tags, Cards, Paper and Findings. Trays a specialty. Fancy Ornaments for Show Windows. 66 Nassau street, New York.

#### Jewelry Manufacturers.

**Aikin, Lambert & Co.**—Manufacturers General stock of Reliable Jewelry, 23 Maiden Lane.

**Alling, Isaac A. & Co.**—Manufacturers of Fine Gold Jewelry. Specialties: Wire Bracelets, Bangles, American Lever Sleeve Buttons. Bryant Building, Nassau and Liberty Streets, N. Y. Factory, Newark, N. J.

**Baldwin, Sexton & Perterson**—Manufacturers of Rich Jewelry, 692 and 694 Broadway, N. Y.

**Ball, W. H.**—Manufacturer of Gold Jewelry. Bracelets and Bangles of all kinds a specialty. 9 John Street, N. Y.

**Barthman, Straat & Co.**—Manufacturers of Fine Jewelry. Roman Goods, Rings, Diamonds. No. 43 Maiden Lane.

**Bissinger, Philip & Co.**—Importers of Diamonds, Pearls and Precious Stones. Sole Agents for the Bohemian Garnet Jewelry, Blue Enameled Lockets. 22 John St., N. Y.

**Brown, Thos. G. & Sons**—Man'rs of Rich Jewelry Necklaces, Locketts, Bracelets, Sleeve Buttons, etc., 860 Broadway, N. Y.

**Bryant & Bentley**—Manufacturing Jewelers. Rings a specialty. 12 Maiden Lane

**Carter, Sloan & Co.**—Manufacturing Jewelers, 15 Maiden Lane, New York.

**Champencis & Co.**—No. 5 Maiden Lane, manufacturers of Engraved and Enameled Gold goods, in Sets, Ear Knobs, Bracelets, Studs, Lace and Shawl Pins, Jet cluster and Onyx goods, also "Best Lever" Sleeve Buttons.

**Chatelier, Joseph F.**—Manufacturing Jeweler, No. 694 Broadway, N. Y.

**Churchill, Lewis & Co.**—Manufacturers of Fine Jewelry. 692 Broadway, cor. Fourth St., N. Y.

**Cook, George W.**—Manufacturer of Fine Jewelry and Locketts, 191 Broadway (over Mercantile Bank,) N. Y.

**Cottle S. Co.**—Manufacturers of Fine Jewelry. 860 Broadway, N. Y.

**Cox & Sedgwick**—Manufacturers of fine Onyx and Colored Jewelry. 26 John St., New York

**Day & Clark**—Manufacturers of Fine Jewelry, Lace Pins, Ear Rings, Studs, Locketts, &c., 10 Maiden Lane, New York.

**Geoffroy, Arthur R. & Co.**—Manufacturing Jewelers. Novelties in Diamond Goods. No. 23 Maiden Lane, N. Y.

**Greene Wm. C. & Co.**—Goldsmiths; Manufacturers of Rich Sets in Taper Wire Coral. Office, 192 Broadway.

**Griffith, H.**—Manufacturing Jeweler. Gold and Plated Jewelry. Scarf Pins a specialty. Nutry Alley, near Concord St., Brooklyn, N. Y.

**Groeschel & Rosman**—Manufacturers of Fine Jewelry. No. 27 John Street, N. Y.

**Hartmann, P.**—Manufacturer & Importer of Fine Gold, Diamond, and Filigree Silver Jewelry, No. 36 Maiden Lane. P. O. Box 2,454.

**Hedges, A. J. & Co.**—Manufacturing Jewelers, 6 Maiden Lane.

**Henderson & Winter**—Jewelers, No. 15 Maiden Lane, New York. Specialties—Stone, Cameo, Onyx, Amethyst, Topaz, Pearl and Turquoise Rings.

**Hunt & Owen.**—Manufacturing Jewelers. Office 3 Maiden Lane.

**Jandorf, P. & Bro.**—Manufacturing and Wholesale Jewelers—all grades. Prompt Attention to Orders. We issue no catalogue. 196 Broadway, N. Y.

**Kipper, Vogel & Co.**—Manufacturing Jewelers, 17 Maiden Lane, New York.

**Kremetz & Co.**—Manufacturing Jewelers. No. 182 Broadway. N. Y.

**Kuhn, Doerflinger & Co.**—Manufacturers of Enameled and Roman Band Bracelets, also Fine Locketts Pendants and Lace Pins. 18 John street.

**Miller Bros.**—Manufacturers of Fine Jewelry, Diamond Goods, Sets, Lace Pins, Ear Rings, Scarf Pins, Sleeve Buttons, Studs, etc. 7 Maiden Lane, N. Y.

**Moore & Horton.**—11 Maiden Lane, Manufacturing Jewelers, Rings, Studs, Collars and Sleeve Buttons, Pins, Ear-rings, &c.

**Muhr's, H., Sons.**—Manufacturing Jewelers. Solid Gold and Filled Rings a specialty. Also Manufacturers of the celebrated Crown Filled Watch Case. 16 Maiden Lane, N. Y.

**Mulford & Bonnet**—No. 21 Maiden Lane, New York.

**Owen, G. & S. & Co.**—Manufacturing Jewelers. Office, No. 3 Maiden Lane.

**Richardson, Enos & Co.**—Manufacturers of Fine Gold Jewelry, Gold Chains, Locketts, Crosses and Necklaces. Colored and Etruscan Work. No. 23 Maiden Lane, New York.

**Richardson, J. W. & Co.**—Manufacturers of Jewelry. Masonic and other Emblems. 196 Broadway, N. Y. Manufactory, Providence, R. I.

**Riley, J. A. & Co.**—Manufacturing Jewelers. Etruscan Gold and Roman Bracelets, Lace Pins, Ear Rings, Scarf Pins, Brooch Pins, etc. No. 860 Broadway, N. Y.

**Ripley, Howland & Co.**—Manufacturers of Fine Jewelry and Platinum Tipped Diamond Settings. No. 17 Maiden Lane, N. Y.

**Schwencke, Wm.**—Manufacturing and Jobbing Jeweler. Repairing a specialty. Orders promptly attended to. No. 43 Maiden Lane, N. Y.

**Sexton & Cole**—Manufacturing Jewelers, Colored Gold and Onyx Goods a specialty. No. 30 Maiden Lane.

**Sheafer, W. H. & Co.**—Manufacturing Jewelers, Specialty Bangles and Bracelets, 15 John St., N. Y.

**Stites' Sons, E.**—Manufacturers of Fine Jewelry. No. 14 John Street, N. Y.

**Street, Geo. O. & Sons.**—Established 1837. Makers of Fine Jewelry, strictly first-class goods of our own make. No. 15 John Street, New York.

**Thoma, Ernest**—Manufacturer of Fine Jewelry, Sleeve Buttons, Rings, Ear-rings, &c. No. 173 Broadway, N. Y. Factory, Hackensack, N. J.

**Ward, Thos. M.**—Manufacturer of Fine Jewelry, Diamond Mountings a specialty. No. 25 John Street, N. Y.

**Wienhold, J.**—Manufacturer of Fine Jewelry. Diamond Mountings a Specialty. 24 John St.

**Woglom & Miller**—Manufacturers of Black Onyx Goods exclusively. 32 & 34 John Street, N. Y.

#### Jewelry—Rolled Plate.

**Blackinton, W. & S.**—Manufacturers of the W. & S. B. Rolled Plated Chains. No. 11 Maiden Lane.

**Frick, John & Co.**—Fine Rolled Plate Jewelry of all kinds. Repairing of every description. 21 and 23 Maiden Lane, N. Y.

**Mauran, J. T.**—Manufacturer of Fine Rolled Plate Jewelry, No. 15 Maiden Lane, N. Y.

**Richards, E. Ira & Co.**—Manufacturers of Fine Rolled Plate Jewelry, No. 200 Broadway, N. Y.

**Jewelers' Tools, etc.**

- Fisher, James J.**—Dealer in Watchmakers' and Jewelers' Materials, Files, Tools, Silk Guards, Spectacles, etc. 695 and 697 Broadway, N. Y.
- Friedenthal, A. & Co.**—Importers and jobbers of Watchmakers' and Jewelers' Tools, Materials, etc. 43 Maiden Lane, N. Y.
- Friedlander, R. & L.**—Importers of Watchmakers' Tools and Materials. 65 & 67 Nassau Street. Branch Office, 264 Bowery.
- Koester, C. F.**—Importer and Manufacturer of Fine Tools, Files and Polishing Materials for Jewelers, Watch Case Makers, etc. 33 John St.
- Kurtz, F. P.**—Manufacturer of Jewelers Machinery, Tools, Rolling Mills, Presses, Polishing Lathes, &c. 97 Cliff St., N. Y.
- Levy, Dreyfus & Co.**—Importers and Jobbers of Watchmakers' and Jewelers' tools and materials of every description. 11 Maiden Lane, N. Y.
- Reichhelm, E. P. & Co.**—Importers of Jewelers' Tools, Files, etc. Manufacturers of Brushes and Buffing wheels; also Patent Gas Furnaces for Melting, Plating, Enamelling, Annealing, etc. 80 Nassau St., N. Y.

**Lapidaries.**

- Fox, M. & Co.**—Practical Lapidaries, No. 1 Maiden Lane, New York.
- Graham & Co.**—Practical Lapidaries, Cutters and Polishers of all kinds of Precious Stones, Emeralds, Rubies, Sapphires, etc. Miner's Relics Cut, Polished and Mounted. Locket Glasses. 80 Nassau St., N. Y.
- Kordmann & Michel.**—Lapidaries. Dealers in Precious Stones. Cutting and Polishing Rubies, Sapphires and other Gems a specialty. Drilling done promptly. 59 Nassau St., N. Y.

**Masonic Jewelry.**

- Luther, John F.**—79 Nassau Street. Manufacturer of Fine Presentation Jewels for all Societies. Knights Templars, Crosses, Badges, &c.
- Wilkinson, C. B.**—Manufacturing Jeweler, 8 John St., N. Y. Medals, Badges and Masonic Jewelry, a specialty. Designs furnished free upon application.

**Optical Goods.**

- Friedlander, R. & L.**—65 and 67 Nassau Street. Dealers in Optical Goods.

**Opticians.**

- Burbank Man'g Co.**—Manufacturers of Spectacles and Eye Glasses of all descriptions, in gold, silver, etc., 14 Maiden Lane, N. Y.
- DuBois, Geo. W. & Co.**—Importers of Watches and Optical Goods. 36 Maiden Lane, N. Y.
- Levy, Dreyfus & Co.**—Importers of Spectacles and Eye Glasses and Optical Instruments of every description, No. 11 Maiden Lane, N. Y.
- Lorsch, Albert**—Manufacturer of the Patent Accommodating Spectacles and Eye Glasses in Gold, Silver and Steel, and other Optical Goods, 37 Maiden Lane, N. Y.
- Spencer Optical Manufacturing Co.**—Gold, Silver, Steel, Nickel and Plated Spectacles; Gold, Celluloid, Steel, Nickel and Rubber Eye Glass and Opera Glasses. 13 Maiden Lane, N. Y.
- Todd, James W.**—No. 20 Maiden Lane, N. Y. Wholesale Dealer in Optical Goods.

**Paper Boxes.**

- Waterbury Paper and Box Co.**, 27 to 35 Canal St., Waterbury, Conn., Manufacture Jewelers' and Silversmiths' Fine Paper Boxes. Quality guaranteed to be equal to the best made.

**Precious Stones, &c.**

- Bishop, Victor & Co.**—33 Maiden Lane, Importers of Precious Stones, Cameos, &c. Also Manufacturers of Coral Jewelry.

**Bissinger, Philip & Co.**—Importer of Diamonds, Pearls and Precious Stones. Agent for the Bohemian Garnet Goods. Blue Enamelled Locket. No. 22 John St., N. Y.

**Breidenbach, R. A.**—Importer of Black Onyx, Diamonds, Pearls, Turquoise, Carnos, Sardonyx, Amethysts, Garnets, Topaz, Opals, Rubies, Sapphires, Hematite Balls, Foil Brilliants, Cat's-Eyes, Tiger Eyes, Doublets, Cabinet Specimens, etc. 85 Nassau Street, New York.

**Daue, Wm. & Co.**—Importer of Precious and Imitation Stones. No. 202 Broadway New York.

**Fox, M. & Co.**—Importers of Diamonds and other Precious Stones, No. 1 Maiden Lane, N. Y.

**Gruet, Jules.**—Importer of all Grades of Real and Imitation Stones. 14 John St., N. Y.

**Hahn & Co.**—Importers of Precious Stones. Cameos, Onyx, Pearls, Intaglios, Amethysts, Garnets, etc. 64 Nassau Street, New York.

**Kahn, L. & M. & Co.**—Importers of precious and imitation stones. 10 Maiden Lane, N. Y.

**Kipling, E. E.**—Importer of Precious and Imitation Stones. Manufacturer of the Patent Foil Solid Metal Back Rhine Stone Brilliant. No. 6 Maiden Lane, N. Y.

**Kipling, R. A.**—Precious and Imitation Stones, No. 24 Maiden Lane, N. Y. Manufacturer Cameos, Agates, Onyx, Etc., Oberstein, Germany. Commission Merchant, 49 Rue De L'Echiquier, Paris.

**Lorsch, Albert**—Importer of Precious Stones, 37 Maiden Lane, N. Y.

**Stirn, Max & Bro.**—Importers of Black Onyx, Cameos, Turquoise, Half Pearls, Sardonyx, Amethysts, Topaz, Garnets, Opals, Rubies, Sapphires, Cat's-Eyes, and all other imitation stones, 3 Maiden Lane, New York.

**Safes.**

**Butler, W. H.**—Fire and Burglar Proof Safes, 291 Broadway, N. Y.

**Silverware.**

**Gorham Manufacturing Co.**—Union Square.

**Knowles, J. P. & S. M.**—Manufacturers of Sterling Silverware, 20 Maiden Lane, N. Y. Factory, Providence, R. I.

**Shiebler, Geo. W.**—Manufacturer of Sterling Silverware. No. 8 Liberty Place, near Maiden Lane, N. Y.

**Whiting Manufacturing Co.**—Makers of Sterling Silver Ware. Broadway cor. 4th Street, N. Y.

**Wood & Hughes.**—Manufacturers of Fine Silverware. 16 John Street, N. Y.

**Silver Filigree Jewelry.**

**Cuppia, L. A.**—Manufacturer of Solid Silver Novelties, and Importer of Silver Filigree, 19 Union Square.

**Francesconi, Guido**—Importer of Silver Filigree Jewelry, 196 Broadway, New York.

**Hartmann, P.**—Manufacturer of Silver Filigree Jewelry. 36 Maiden Lane, N. Y.

**Silver Plated Ware.**

**Manhattan Silver Plate Co.**—Manufacturers of Silver Plated Ware. Showrooms, 23 John St. Factory, 301 to 305 East 22d St., cor. 2d Ave. Address all communications to Factory.

**Middletown Plate Co.**—Manufacturers of Superior Electro-Plate. Factories, Middletown, Conn., salesroom, 13 John Street.

**Rogers, Smith & Co.**—Manufacturers of Fine Electro Plated Ware. No. 46 E. 14th St., N. Y.

**Simpson, Hall, Miller & Co.**—Manufacturers of fine Silver-Plated Ware. No. 36 E. 14th Street.

**Schade, Henry.**—Manufacturer of White Metal and Plated Ware. Office, 26 John Street, N. Y. Price list and catalogue furnished on application.

**The Derby Silver Co.**—Manufacturers of Finest Quadruple Silver Plated Ware, Birmingham, Conn. New York office, 25 Maiden Lane.

**Webster, E. G. & Bro.**—Manufacturers of Fine Silver-Plated Ware. Office and warerooms, 14 Maiden Lane, N. Y.

**Show Cases, Etc.**

**Smith, B. & W. B.**—Manufacturers of Patent Improved Dust Proof Show Cases, with Perpendicular Sliding Doors. No. 220 W. 29th St., N. Y.

**Spectacle Case Manufacturers.**

**Bertine, P. D.**—Manufacturer of Spectacle and Eye-Glass Cases. 139 William Street, near Fulton St., New York.

**Koenen, A. & Bro.**—Manufacturers of Leather Spectacle and Eye-Glass Cases for the Jobbing Trade only. 81 Nassau St., N. Y.

**Stem Winding Attachments.**

**Abbott, Henry** Maker of Stem Winding Attachments, No. 4 Maiden Lane, N. Y.

**Swivels and Spring Rings.**

**Schwartz, V. & Co.**—Manufacturers of Gold Swivel and Chain Trimmings. 33 Barclay Street, New York.

**Thermometers, Etc.**

**Tagliabue, Giuseppe.**—manufacturer of Thermometers, Barometers and Hydrometers. Patentee and sole manufacturer of the U. S. Standard Hydrometer. 302 Pearl Street, near Beekman.

**Thimble Manufacturers.**

**Burbank Manufg Co.**—Manufacturers of Gold and Silver Thimbles, 14 Maiden Lane, N. Y.

**Ketcham & McDougall.**—Improved Gold and Silver Thimbles, Bryant Building, N. Y.

**Simons Bro. & Co.**—Manufacturers of Gold and Silver Thimbles. 611 and 613 Sansom Street, Philadelphia.

**Woglom & Miller.**—Sole Agents for the "Prime" Thimbles in Gold and Silver, manufactured by Ezra C. Prime. 34 John Street, N. Y.

**Trunks.**

**Crouch & Fitzgerald**—Manufacturers of Trunks and Articles for Travelers' use. 1 Cortlandt St., 556 Broadway, and 723 Sixth Ave., N. Y.

**Watch Companies.**

**American Watch Co.**—Robbins & Appleton, No. 5 Bond Street, N. Y.

**Illinois Watch Co.**—Springfield, Illinois. 21 Maiden Lane, N. Y. and 71 Washington Street, Chicago, Ills.

**The E. Howard Watch and Clock Co.**—Cor. Maiden Lane and Nassau Street, N. Y.

**Waterbury Watch Co.**—Manufacturers of the Waterbury Watch. Factory, Waterbury. Office, 52 Maiden Lane, N. Y.

**Watch and Chronometer Jeweler.**

**Queen, James.**—Watch and Chronometer Jeweler and Pallet Maker, 78 Nassau Street, room 8. Pivots inserted in Pinions, Balance, Staffs, etc.

**Robert, Henry L.**—Practical Chronometer and Watch Jeweler and Adjuster. 71 Nassau Street. Pallet and Hole Jewels for Chronometer Watches done in the best manner.

**Wennstrom, John.**—Watch, Chronometer and Clock Jeweler, Jewel Gauges, Ruby and Sapphire Draw Plates; Diamond Charged Polishing Stones for Jewel Settings; Pivots inserted in Pinions. 2 Dutch Street, N. Y.

**Watch Importers, Etc.**

**Abry, Chas. Leo**—Importer and Manufacturer of Swiss Watches of all grades. 63 Nassau Street.

**Aikin, Lambert & Co.**—Importers of Watches. Sole Agents for Paul Breton & Chas. Latour, Geneva. A general line of reliable Swiss Watches, Watch Cases, etc. 23 Maiden Lane, N. Y.

**Bartens & Rice**—20 John Street, Importers of Watches and sole agents in the United States for the celebrated Nicolé, Nielsen & Co. Watches.

**Cross & Beguelin.**—Importers of Watches, Watch Tools and Materials, dealers in American Watches, No. 21 Maiden Lane, N. Y.

**Droz, Henry E.**—Importer of Watches, and Watch Case Manufacturer. Agent for the "E. Perre-gaux" Watch, and jobber in American Watches No. 92 Fulton Street, N. Y.

**Freund Max & Co.**—Importers of Watches, Jewelry and Precious Stones, 8 Maiden Lane, N. Y.



**Gagnebin, Chas.**—Importer of all kinds of Swiss, and Dealer in American Watches. 4 Maiden Lane, N. Y. Agent for Ulysse Breting's Fine Chronometers, Chronographs, Anchors, &c.

**Gallet, Julien.**—Importer of Watches. No. 1 Maiden Lane.

**Ginnel, Henry.**—Importer of Watches, Tools and Materials, 31 Maiden Lane, N. Y. P. O. Box 2967

**Hyde's Sons, John E.**—Wholesale Commission Agents, only for Jules Jurgensen, of Copenhagen; Jules Monard, of Geneva; and for other makers of all qualities of Watches, 22 Maiden Lane.

**Keller, L. H. & Co.**—Successors to G. A. Huguenin, Importers of Fine Watch and French Clock Materials, No. 64 Nassau Street, N. Y.

**Mathey Bros. & Mathez.**—Importers of Fine Watches and Sole Agents for the **H. L. Matile's** Watches. No. 16 Maiden Lane.

**Robert, J. Eugene.**—No. 30 Maiden Lane, New York. Agent for Louis Audemar's celebrated watches.

**Schumann, Chas. W.**—No. 24 John Street, New York. Importer of Fine Diamonds, Watches, etc. Sole Agent in the U. S. for the celebrated "Lange" Dresden Watch.

**Schwob, Adolphe.**—Manufacturer and Importer of Watches, 11 Maiden Lane, N. Y.

**Strasburger, Louis & Co.**—Importers and Makers of Watches of every description, 15 Maiden Lane.

#### Watch Cases.

**Dueber Watch Case Mfg Co.**—Manufacturers of Gold and Silver Watch Cases. Bryant Building, N. Y. Factory, Newport, Ky.

**Fahys, Joseph.**—Manufacturer of Watch Cases and Dealer in American Movements, 38 Maiden Lane.

**Glatz, Chas.**—Manufacturer of Silver Watch Cases. Bryant Building, cor. Nassau and Liberty Sts.

**Keller & Untermeyer.**—Manufacturers of Watch Cases with Raised Gold Ornaments. 9 Maiden Lane, N. Y.

**Ladd Watch Case Co.**—Manufacturers of the Ladd Patent Stiffened Gold Watch Cases, etc., 11 Maiden Lane, N. Y. Factory, 58 Eddy Street, Providence, R. I.

**Martins & Tissot.**—Manufacturers of Gold Watch Cases. No. 15 Maiden Lane, N. Y.

**The Brooklyn Watch Case Co.**—Manufacturers of the celebrated Eagle Case. 40 Maiden Lane.

**Willemin Watch Case Co.**—Makers of Gold Watch Cases. Raised Gold Ornamentation and Jurgensen style of Engine Turning. 109 Sands Street, Brooklyn, N. Y. 16 Maiden Lane, N. Y.

#### Watch and Chronometer Repairers.

**Cerf, B.**—Practical Watchmaker and Repairer, No. 10 John Street, N. Y. Repairing and adjusting of Fine Watches done for the trade. All kinds of escape and stem-winding wheels cut to order.

**Goepf, Frederick A.**—Practical Watchmaker. Repairing of every description for the Trade. 25 Maiden Lane, N. Y. In office of H. Garland, Engraver.

**Heinrich, H. H. & Co.**—Sole Manufacturers of H. H. Heinrich's Patent Auxiliary Balance, and Adjusters and Repairers of Fine Watches and Chronometers. 18 John Street, N. Y.

**La Croix, J. H.**—(Late with Benedict's Time.) Watch and Clock Maker, 21 John Street, N. Y. Clocks of every description Repaired for the Trade.

**Lesperance, Theo.**—Watchmaker and Wheel Cutter. No. 1 Maiden Lane, New York. With Julien Gallet.

#### Watch Case Repairers.

**Feinier, Joseph A.**—Watch Case Maker and General Repairer. Specialty in fine Gold and Silver Cases. Jobbing promptly attended to. Nos. 4 and 6 John St., N. Y.

**Perret & Jardon.**—Watch Case and Spring Repairers. No. 80 Nassau St. (top floor), N. Y. Cases and Springs of all kinds neatly repaired.

**Tarbox, Hiram.**—Watch Case Repairing, Springing, Polishing and Engine Turning. 1874 North Fourth Avenue, bet. 176th and 177th Sts., N. Y. Express Packages should be sent to 92 Fulton Street.

#### Watch Glasses, Shades, Etc.

**Brown, Edwin H.**—No. 85 Nassau Street, Imported and Own Manufacture Watch Glasses, Flat, Flat Concave, Concave, Convex and fine Genevas, Fine fitting solicited.

#### Watches, Diamonds and Jewelry.

**Alford, C. G. & Co.**—Manufacturers. General line fine and Reliable Goods, Specialties in Onyx Goods and Chain. 200 Broadway, New York.

**Cohn, J. J.**—Importer and Manufacturer of Whity Jet, Rubber and Pearl goods. Gold and Rolled-plate Jewelry, etc. 12 Maiden Lane, New York.

**Durfey & Reynolds.**—Successors to Durfey & Shiebler, Watches, Diamonds, Jewelry. No. 9 John Street, (up-stairs) New York.

**Friedman, Saml.**—Wholesale Dealer in Watches and Jewelry, 42 Maiden Lane, N. Y.

**Goddard, John M.**—Manufacturing Jeweler.—Seal Rings and Fine Locketts a specialty, No. 3 Maiden Lane, N. Y.

**Greason J. R. & Co.**—Successors to Arthur, Rumrill & Co., 182 Broadway. Manufacturers of Fine Jewelry and Gold Chains, also Diamond Mountings.

**Haskell, H. C.**—Manufacturing Jeweler. Seal Rings a specialty. Special attention to Jobbing of every description. 12 John street.

**Herzog, Louis & Co.**—Importers of Watches, Dealers in Diamonds and Jewelry, 52 Maiden Lane, N. Y.

**Hirsch Bros.**—Dealers in Watches and Diamonds and Manufacturers of Jewelry, No. 23 Maiden Lane, N. Y.

**Jandorf, P. & Bro.**—Importers of Watches and Jewelry, 196 Broadway.

**Kennedy, Frank S.**—Manufacturer and Wholesale Dealer in Jewelry and Gold and Silver Thimbles. No. 13 Maiden Lane, New York.

**Lissauer & Sondheim.**—Wholesale Jewelers and Jobbers in American Watches, No. 12 Maiden Lane, N. Y.

**Marx, Kossuth & Co.**—Importers of Watches and Dealers in Jewelry. 39 Maiden Lane, N. Y.

**May, Henry.**—Importer and Wholesale Dealer in Watches and Diamonds, and Manufacturing Jeweler. 19 John St., N. Y.

**Mayer, B.**—Manufacturer of Fine Jewelry, and Dealer in Watches, 71 Nassau street, cor. John street, New York.

**Myers, S. F. & Co.**—Manufacturing and Wholesale Jewelers—all grades. Importers of Watches. Illustrated Catalogue to the trade. 179 Broadway, N. Y.

**Oppenheimer Bros. & Veith.**—Dealers in Watches and Diamonds, and Manufacturing Jewelers, No. 35 Maiden Lane.

**Scott, J. T. & Co.**—Importers of Watches, and Manufacturers of Jewelry, and Jobbers of all Grades of American Watches, 4 Maiden Lane.

**Smith & Knapp.**—Wholesale Dealers in American and Swiss Watches, Diamonds, Gold and Plated Jewelry and Gold Chain. 182 Broadway, N. Y.

**Steele, J. W.**—Successor to Brainerd, Steele & Co., Manufacturer of Fine Jewelry and Brainerd's Patent Locketts. No. 9 Maiden Lane, N. Y.

**Stern Brothers & Co.**—Importers of Swiss Watches and wholesale dealers in American Watches, &c., 39 Maiden Lane.

**Stern & Stern.**—Dealers in Watches, Jewelry and Diamonds. No. 6 Maiden Lane, N. Y.

**Stites, D. H. & Son.**—Manufacturers of Fine Jewelry, Rolled Plated Goods and Chains, Parisian Diamond Rings, Studs and Earrings a specialty. 41 Maiden Lane, N. Y.

**Strauss, Jacob.**—Full Line of Gold and Plated Jewelry, and Importer of Watches. 18 John Street, New York.

**Thrall, E. A.**—Wholesale Dealer in Watches and Jewelry. No. 1 Maiden Lane, N. Y.

**Trier Bros.**—Importers of Garnet, Whity Jet and Amber Jewelry, Silk Guards, Opera, Field and Marine Glasses, Pearl Card Cases. Also a full line of Gold and Plated Jewelry. 15 Maiden Lane, N. Y.

**Wheeler, Parsons & Hays.**—Manufacturers of Fine Jewelry, Watch Cases, Gold Chains, &c. and Dealer in American and Swiss Watches, No. 2 Maiden Lane, N. Y.

**White, N. H.**—Jobber in American-Waltham Watches and Chronographs. Waltham make of 10-k., 14-k. and 18-k. Gold and Sterling Silver Cases; Filled Gold Cases. 11 Maiden Lane.

#### Watch Tools, etc.

**Keller, L. H. & Co.**—Importers of Watchmakers' and Jewelers' Tools, Materials, etc. 64 Nassau Street, N. Y.

**Zimmern, Henry.**—Importer of Watch Materials, Tools, and Optical Goods, No. 8 Maiden Lane, (first floor.) Sole Agent for A. Huguenin & Gravier. Mainsprings, New York.

#### PHILADELPHIA

**Bennett, Jacob & Son.**—Diamond Setters and Manufacturing Jewelers, 925 Chestnut St.

**Bernard & Co.**—Manufacturers of Fine Roman and Etruscan Jewelry. Designs of every description made to order, 123 & 125 South Eleventh Street, Philadelphia.

**Booz & Co.**—Makers of Fine Gold Watch Cases and Plain Gold Rings, also Dealers in all American Movements, Diamonds, Jewelry, etc. 108 South 8th Street, Philadelphia.

**Conover David F. & Co.**—American Watches, Wholesale Salesroom, Southeast corner 7th and Chestnut Streets, Philadelphia.

**Herold, Chas P.**—Successor to Hildebrandt, Herold & Co., Manufacturing Jeweler and Diamond Setter. Diamonds. 916 Chestnut Street.

**Krieder, Peter L.**—Manufacturer of Sterling Silver Ware. 618 Chestnut Street, Philadelphia.

**McCall & Newman.**—Manufacturing Jewelers. Makers of the Original Gold Crown Filled Rings. No. 625 Arch St., Philadelphia.

**Morgan & Headly.**—Manufacturing Jewelers. Cameo Sets, Gold Sets, Roman Locketts, Rings, Coral Sets and a general line of rich goods. Corner 10th and Chestnut Streets, Philadelphia.

**Muhr's, H., Sons.**—Manufacturing Jewelers. Solid Gold and Filled Rings a specialty. 633 and 635 Chestnut Street, Philadelphia. 1 1/2 Maiden Lane, New York.

**Peters, Reese S.**—Manufacturer of Patent Rolled Plate or Filled Watch Cases, Dealer in American Movements, 308 Chestnut Street, Philadelphia.

**Rosenthal, G. F. C.**—Manufacturing Jeweler and Diamond Setter. Engraving and Designing of Monograms a specialty. No. 917 Sansom Street.

**Scherr, L. A. & Co.**—Wholesale Dealers in Watches Silver-Plated Ware, Spectacles, Fancy Goods, Watch Materials, etc. 726 Chestnut Street.

**Sheafer, W. H. & Co.**—Manufacturing Jewelers. Specialty: Band Bracelets. Factory, 612 and 614 Chestnut street, Philadelphia. Office, 15 John street, New York.

**Simons, Brother & Co.**—Manufacturers of Fine Jewelry, Canes, Thimbles, Chains. 611 and 613 Sansom Street.

#### CHICAGO.

**American Watch Company.**—of Waltham, Mass. No. 102 State Street, Chicago.

**Clapp & Davies.**—Wholesale Jewelers, 63 and 65 Washington Street. Catalogue and price list issued to watchmakers and jewelers.

**Dennison Manufacturing Co.**—Manufacturers of Jewelers' Paper Boxes, Morocco Cases, Tags, Cards; Pink and White Cotton, Tissue Papers, Sealing Wax, &c., &c., 102 Madison St., Chicago. Boston, New York, St. Louis, and Philadelphia.

**Gilbert, Wm. L., Clock Co.**—Manufacturers of Clocks, Regulators, and Time Pieces, and Clock Material of every description, 54 and 56 Madison Street, Chicago.

**Giles, Bro. & Co.**—Manufacturers and Jobbers in Watches, all classes of Jewelry, Materials, Clocks, Silver Ware, &c. Illustrated catalogues furnished to dealers on application. 101 & 103 State St.

#### NEWARK.

**Baker & Co.**—Gold, Silver and Platinum Refiners, Assayers and Sweep Smelters. 408 New Jersey Railroad Avenue, cor. Murray St., Newark, N. J.

**Diefenthaler Bros. & O'Donnell.**—Manufacturers of Fine Jewelry, Lace Pins, Ear Rings and Patent Spring Bangles a Specialty. 36 Crawford Street, Newark, N. J.

**English & Miller**—Manufacturers of Gold Jewelry, Diamond and Fancy Stone Rings, Roman Lockets, Bangle and Flexible Bracelets, Knife Edge Lace Pins and Sets, Scarf Pins and Link Buttons. 61 and 63 Hamilton St., Newark.

**Felger, F. & F.**—Manufacturing Jewelers. Specialties:—Roman Band Bracelets, Lace Pins, Scarf Pins, Ball and Fancy Ear Rings. No. 477 Washington Street, Newark, N. J.

**Fiedler, Herrman**—Successor to Kunze & Fiedler, Engraver, Die Sinker and Press Tool Maker, 363 Market Street, Opposite Pennsylvania R. R. Depot, Newark, N. J.

**Glorieux, W. L.**—Assayer, Refiner and Sweep Smelter. 13 and 15 Franklin Street, Newark, N. J.

**Hopper & Wilson**—Manufacturers of Fine Jewelry, No. 8 Maple Place, Rear 44 Green St., Newark, N. J.

**Huger & Heitlinger**—Manufacturers to the Jobbing Trade only. Makers of Roman, Stone, Engraved and Enameled Lockets a specialty. Also Sleeve Buttons, Collar Buttons and Studs. 477 Washington Street, Newark, N. J.

**Krippendorf, C. & Schuller, F.**—Machinists and Jewelers' Tool Makers. 19 Greene Street, Newark, N. J. Rolls, Dies, Cutters, and Draw-plates of every Description made and repaired.

**Lelong, L. & Bro.**—Gold and Silver Refiners. Assayers and Sweep Smelters, Southwest corner of Halsey and Marshall Streets, Newark, N. J.

**Milne, Alex.**—Manufacturer of Stem-winding Watch Crowns. 19 Ward Street.

**Nesler & Co.**—Manufacturers of 18 Kt. Gold Filled Hoop Ear Rings, Plain, Facet and Engraved, all sizes. 36 Crawford St., Newark, N. J.

**Regad, E. D.**—Lapidary. Specialty—Sardonyx, Black Onyx and Agates. 14 Oliver St., Newark.

## PROVIDENCE

**Arnold & Webster**—Manufacturers of Solid Gold Engraved Band Rings for the Jobbing Trade. 29 Point Street, Providence, R. I.

**Butts, Geo. F.**—Manufacturing Jeweler. Ladies' and Misses' Solid Gold Drops and Studs a Specialty. 119 Orange Street, Providence, R. I.

**Bradley, R. & Son**—Manufacturers of Solid Gold and Rolled Plate Jewelry. White Stone Goods a Specialty. 227 Eddy Street, Providence, R. I.

**Capron & Co.**—Manufacturers of Jewelry. Engraved Box Bracelets, Bangle Wire Bracelets, Original Lever Collar and Cuff Button. No. 407 Pine Street, Providence, R. I.

**Elmwood Paper Box Co.**—Makers of Jewelers' Cases, Trays, etc. Factory, 54 Greenwich St., Providence, R. I.

**Hamilton, William & Co.**—Manufacturers of Fine Rolled Plated Chains and Patent Band Bracelets. 116 Pine St., Providence, R. I.

**Harrington, J. C.**—Maker of Fine Gold Plated Jewelry. Specialties:—Oval Wire Bangles, Band Bracelets and the Victor Swivel. 129 Eddy St., Providence, R. I.

**Hough, W. S., Jr., & Co.**—Manufacturers of the Hough, Jr., Rolled Plate Lockets, Charms and Pendants. For sale by all first-class Jobbers or Wholesale Jewelers in the United States and Canadas.

**Hutchison & Huestis**—Makers of Solid Gold Rings. Quality guaranteed. For the Jobbing Trade only. 185 Eddy Street, Providence, R. I.

**Irons, Chas. F.**—Manufacturer of Solid Gold Jewelry. Specialty, Emblems, Pins and Charms, Masonic, Odd Fellows, etc. 102 Friendship St.

**Pitts & Hicks**—Manufacturers of the Excelsior Button and Eclipse Lever Button, also a line of White Stone Gold Goods and a fine line of Lace Pins and Drops in Rolled Plate Goods. 120 Dorrance Street, Providence, R. I.

**Taylor, Geo. H. & Co.**—Watchmakers and Wholesale Dealers in Watches, Clocks, Watch and Clock Material, Tools, Spectacles, Eye Glasses, &c. Particular attention given to trade work. 136 Westminster Street (Room 1), Providence, R. I.

## PAWTUCKET.

**Fuller, Geo. H. & Son**—Jewelers' Findings, Gold, Silver, Gold Plated and Fire Gilt. Pin Stems, Joints, Catches, Split Rings, Chain Hooks and Swivels, Ear Wires, Chain Bars, etc. 99 Exchange Street, Pawtucket, R. I.

## CINCINNATI.

**Holland, John**—Manufacturer of Gold Pens, Pencils and Pencil Cases, Gold Toothpicks, etc. Nos. 19 and 21 W. 4th St., Cincinnati, Ohio.

**Lodwick & Nolting**—Wholesale Jewelers (exclusively), S. W. cor. Fourth and Walnut Streets, Cincinnati, Ohio.

## BOSTON.

**Boston Watch Case Co.**, makers of Watch Cases. Especial attention given to Repairing. 1, 3 & 5 Province Court, Boston, Mass.

**Boyce, E. J.**—Manufacturer of Solid Gold Jewelry. Rings a Specialty. 383 Washington St., Boston, Mass.

**Weber, H. & Co.**—Wholesale Jewelers, Importers and Jobbers of Fine Watch Materials, Jewelers' Findings, Tools, etc., Optical Goods and Silk Guards. Agents for Whitcomb, Standard and Stark's Lathes. 424 Washington St., Boston, Mass.

## BUFFALO.

**Oliver, W. W.**—Manufacturer of Hand and Power Rolling Mills for Jewelers and Silversmiths, 39 Clinton Street, Buffalo, N. Y.

## CLEVELAND.

**Chandler, J. M. & Co.**—Manufacturers of the Patent Embossed Bracelet and Jobbers in all kinds of Clocks, Watches, Jewelry, Tools, Materials, etc. 185 Superior St., Cleveland, O.

## LANCASTER.

**Bowman & Musser**—Jobbers in Watches, Clocks, Chains, Fine Tools and Materials. 20 East Chestnut Street, Lancaster, Pa.

## PITTSBURGH.

**Goddard, Hill & Co.**—Wholesale Dealers in American Watches, Jewelry, Silverware, Clocks, Materials, &c., 43 Fifth Avenue, Pittsburgh, Pa.

**Hodge, Slemmons & Co.**—Wholesale Dealers in American and Swiss Watches, Diamonds, Gold and Plated Jewelry, Clock Material, etc. No. 77 Fifth Ave., Pittsburgh.

## NEW BEDFORD.

**Nye, W. F.**—Manufacturer of Watch, Clock and Chronometer Oils, New Bedford, Mass.

**Wheeler, G. B.**—Manufacturer of Watch and Chronometer Oils, New Bedford, Mass.

## WORCESTER.

**Washburn & Moen Manufacturing Co.**—Makers of Fine Watch Mainsprings, Worcester, Mass. 16 Cliff Street, New York. 107 to 109 Lake Street, Chicago, Ill.

## WINCHESTER.

**Goodell & Winn**—Manufacturers of American Watch Hands, Winchester, Mass.

## ALBANY.

**Reiss, Chas.**—31 and 33 So. Pearl Street, Albany, N. Y. Importer of Watch Tools and Material; General Supply; Low Prices. Repairing for the Trade.

## CANADA.

**Ellis, P. W. & Co.**, No. 31 King street, East Toronto, Ontario, Manufacturing Jewelers, Watchmakers, importers and Jobbers of Watchmakers, and Jewelers' Tools, Materials, General Supplies and American Jewelry. Correspondence solicited with manufacturers of Novelties or specialties in American Tools and Jewelry.

GEO. W. DUBOIS.

F. N. NAUMAN.

## GEO. W. DUBOIS & CO.,

IMPORTERS OF

## Watches & Optical Goods.

ALL STYLES AND QUALITIES OF

### SPECTACLES AND EYE-GLASSES.

## Longines' Watches and Movements,

The Watches in Gold, Silver and Nickel Cases of New and Handsome Patterns. The Movements fit 18 size Waltham Stem Winding Hunting Cases.

36 Maiden Lane, New York.

ORDERS BY MAIL RECEIVE PROMPT ATTENTION.

## BARNES' No. 4 LATHE, For the Heavier Work of Jewelers.

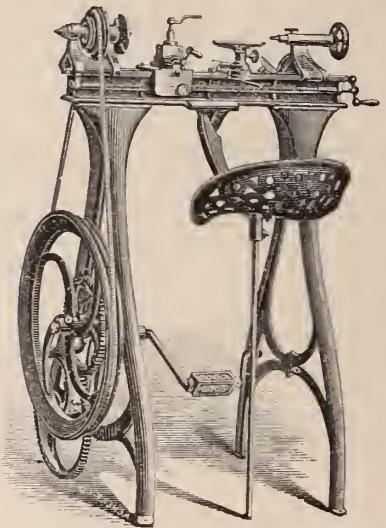

Barnes' Patent Foot and Steam Power Machinery. Complete outfits for Actual Workshop Business. Lathes for wood or metal. Circular Saws, Scroll Saws, Formers, Mortisers, Tenoners, etc., etc. Machines on trial if desired. Descriptive Catalogue and Price List Free.

W. F. & JOHN BARNES,  
2088 Main Street, ROCKFORD, ILL.

## EXCELSIOR'S

Practical Treatise

ON THE

## BALANCE SPRING

Including Making and Fitting Hair Springs, Regulating, etc.

Also containing the Adjustment of Watches and Chronometers for Isochronism, Positions, Heat and Cold and Rate.

PRICE, \$3.50.

D. H. HOPKINSON,

42 Nassau Street, New York.

**EUREKA**  
PAT. OVAL SPLIT RINGS.

WM. M. FISHER & CO.,  
MANUFACTURERS OF

Gold & Silver Chains  
AND  
CHAIN TRIMMINGS,

Factory, 226 EDDY ST., PROVIDENCE, R. I.,  
Where all correspondence should be addressed.

NEW YORK OFFICE, No. 13 JOHN STREET.

We beg to call your attention to our new  
**Eureka Oval Split Rings,**  
Better Shape, More Easily Adjusted and Warranted  
**To Stand Fifty Per Cent.**  
*More Strain than Round Ones  
of same Size and Weight.*

FOR SALE BY ALL JOBBERS.  
\*SEND ALONG YOUR ORDERS\*

**EUREKA.**

1  
2  
3  
4  
5  
6  
7  
8  
9

**REST FENNER SMITH & CO.**

MANUFACTURERS OF  
**FINE GOLD & SILVER HEADED  
CANES**

701 BROADWAY  
N.Y.

SPECIAL FACILITIES FOR FURNISHING  
INDIVIDUAL IDEAS SYMBOLS, GRAFTS  
OR PROFESSIONS.

SEND FOR ILLUSTRATED CATALOGUE.

**KEY**  
Patented Jan. 25,  
1881.

**TAG**  
Patented Jan. 25,  
1881.

**A. N. CLARK**  
PLAINVILLE,  
CONN.,  
Manufacturer of

Watch Case Springs, Watchmakers' & Jewelers' Bench Tools,  
**CROSBY'S JEWELING TOOLS, &c.**

**STOP IMPORTING KEYS!**  
For Low Price Key Use the  
**New Style Loop Key.**

A plain Steel Key of good appearance, and excellent quality. It will not wear the pocket. It has a swivel, and is much better made than the imported plain steel or iron keys.

**PRICE PER GROSS, FINE NICKEL FINISH, \$2.25**  
Postage, 10 Cents Per Gross Additional.

This Key is good and cheap enough to become universal. Send business card for illustrated price list. Enclose three cent stamp for sample key.

SOLD BY JOBBERS IN WATCH MATERIALS AND NOTIONS.  
**A. N. CLARK, Plainville, Conn.**

**The Burbank Manufacturing Company**  
Manufacturers of **GOLD & SILVER**

**Thimbles,**

**EYE GLASS**  
Self Adjusting.

**GOLD SILVER, STEEL, RUBBER, And SHELL,**

**SPECTACLES AND EYE-GLASSES**

**OF ALL DESCRIPTIONS.**

**SOLID GOLD RINGS**  
**Office, 14 MAIDEN LANE. NEW YORK.**  
Manufactory, Springfield, Mass.

# Spencer Optical Manuf'g Co.

ARE MAKING MANY  
**NEW AND DESIRABLE STYLES**  
 FOR THE  
**EARLY FALL TRADE.**  
**BETTER FINISH.**  
 PRICES THE LOWEST.

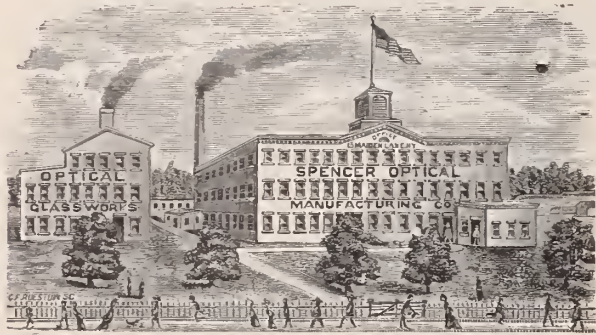

## INDESTRUCTIBLE CELLULOID SPECTACLES.

Our Gold Goods are Unsurpassed for  
**Beauty, Durability and Finish.**  
**QUALITY GUARANTEED.**

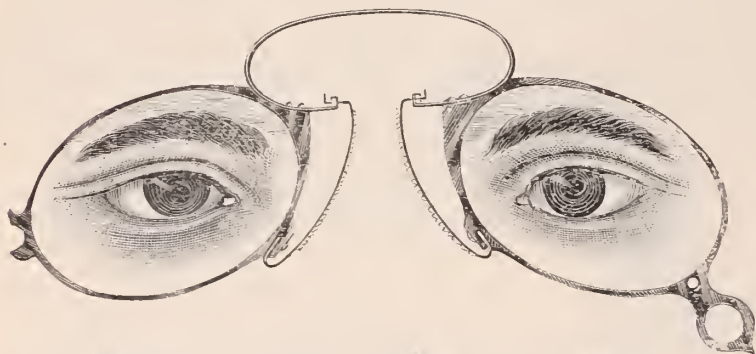

### CELLULOID SPECTACLES.

The very latest improvement, made in Shell and Amber Color; it has substantial advantages over all others, being strong, light and not subject to rust.

### THE CELLULOID EYE-GLASS

has made its own reputation and is universally popular wherever introduced.

**BEWARE OF IMITATIONS.**

If you wish a Specialty, call on us.

We make a **SPECIALTY** in **SPECIAL GOODS** for the **FINE RETAIL TRADE**, which gives customers handling our goods **IMMENSE ADVANTAGE** over all others.

**QUALITY OF GOLD GUARANTEED.**

We are importing large Invoices of Opera, Field and Marine Glasses in Staple and Novel Designs.

Catalogue sent on receipt of Business Card.

**Spencer Optical Manufacturing Co.,**  
 13 MAIDEN LANE, NEW YORK.

Established 1853.

# L. H. KELLER & CO.

Successors to G. A. HUGUENIN,

IMPORTERS OF

**WATCHMAKERS' and JEWELERS'**  
**TOOLS AND MATERIALS.**

GENERAL AGENTS FOR

The Philadelphia Watch Company,

— AND —

American Watch Tool Co.,

MANUFACTURERS OF

**THE WHITCOMB LATHE.**

SOLE AGENTS IN THE UNITED STATES FOR THE SALE OF

**LUTZ'S**  
**CELEBRATED ROLL HARDENED HAIR SPRINGS,**  
**MOEBIUS OIL**

For Chronometers, Watches, Clocks, Telegraph Instruments and all other delicate machinery. Made from Pure Refined Neatsfoot Oil, and Warranted to Excel anything in the market as a Lubricator. **SAMPLES GRATIS.**

**OUR OWN GRADUATED**

**AND JURGENSEN RECOILING MAINSPRINGS,** pronounced by all experts Superior to all. Sold in Separate Strengths or Force.

Extra Fine Pinions cut from Solid Steel Wire. Gauged Hole Jewels of First-class Workmanship. A Full Line of Materials, for the **PATEK, PHILIPPE & CO. GENEVA WATCHES,** and all other Celebrated Makers.

### THE BOLEY LATHES AND TOOLS,

Celebrated for their Practical, Substantial and Workmanlike Construction, Superior Design and Finish.

*Our aim is to furnish nothing but First-class Serviceable Goods, especially manufactured for the Consumer, and not solely for the Market, like the cheap trash advertised in highly illustrated catalogues with which the country is flooded.*

**TREATISE ON MODERN HOROLOGY IN THEORY AND PRACTICE.** By M. CLAUDIUS SAUNIER, Ex-Director of the School of Horology at Macon, France; Knight of the Legion of Honor, etc.; Hon. Sec. to the Paris Society of Horologists. Translated from the French by JULIEN TRIPPLIN, Besançon Watch Manufacturer, and EDWARD RIGG, M. A., Assayer in the Royal Mint, London.

This Work comprises 832 large octavo pages, with 78 wood cuts and 21 colored double-page copper-plate engravings. Bound in half calf, with an appropriate and handsome ornament in gold on front cover.

**Price, \$15.00.**

**THE WATCHMAKER'S HAND BOOK.** By the same author and translators. Intended as a companion to the Treatise. Bound in cloth.

**PRICE, \$4.00.**

**64 Nassau Street,**

NEAR MAIDEN LANE,

**NEW YORK.**

L. H. KELLER,  
 EDWARD HUNZIKER,  
 F. J. BOESSE.

We do not publish Price Lists.

**SPECIAL NOTICES.**

**Notices under this heading, not to exceed Six Lines, \$1.00 each insertion.**

Advertisers having letters addressed in care of this office, must inclose postage for answers forwarded.

**WANTED**—Salesman immediately, who is acquainted with eastern and near-by trade. Address M. C., care of Jewelers' Circular.

**SITUATION** wanted by a thoroughly competent watchmaker. Pennsylvania preferred. Those who want shop-boys need not address. watchmaker, care Jewelers' Circular.

**WANTED**—A permanent position by a general jeweler, letter and monogram engraver, one who is accustomed to charge of job shop. Address H. H. A., care of Circular.

**WANTED**—Situation by a good watch repairer. Best of reference and tools. First-class American lathe. Address A., care L. Balr, 121 E. Federal street, Youngstown, Ohio.

**WANTED**—By a young man, situation as watchmaker or salesman, is also a fair engraver. Can furnish the best references. Address H., Box 340, Matteawan, Dutchess Co., N. Y.

**A SALESMAN** of pleasant address is desirous of making an engagement with a manufacturer of silver plate goods, to travel south or west. Address Representative, care Jewelers' Circular.

**An experienced salesman** wishes to make an arrangement with a manufacturing jewelry or watch house. Can furnish best of references. For particulars address X. Y. Z., Jewelers' Circular.

**SITUATION** wanted by a competent watchmaker, engraver and jeweler. Has had six years' experience. Best of reference given. Would prefer Minneapolis or St. Paul. Address S. D. Elwood, Big Rapids, Mich.

**WANTED**—A situation by a practical watchmaker and engraver, is also a good salesman. A first-class workman in every respect. Best of recommendations given. Address A. K. Townsend, Norwalk, Ohio.

**FOR SALE**—Our branch jewelry store, "only jewelry store in the Arcade." Town of 32,000 inhabitants. Good trade established. Small capital required, as we will reduce stock to suit. Hofman & Co., Springfield, Ohio.

**FOR SALE**—Jewelry business in a good and growing town in Florida. \$2,000 required to buy the dwelling house and lot, store house and lot, safe, show cases and regulator. Address Jacob Strauss, 25 John street, New York.

**MOSELEY & CO.**, Elgin, Ill., manufacturers of the "Moseley" Lathe, with full line of fixtures and attachments. Designed especially for the watchmaker and repairer. Combining accuracy, durability, convenience and style.

**SITUATION** wanted by a first-class watchmaker, competent to take charge of repairing department and store if desired; temperate and industrious; N. Western city preferred; best of reference. Address, Geo. Davis, 17 S. Gay St., Baltimore, Md.

**FOR SALE**—A well located jewelry store in a thriving town in Minn.; has good run of trade and job work. Amount of stock about \$1,500. A good chance for a man to start into a paying business. Stock must be sold. Address, Call Box 113, Montevideo, Minn.

**FOR RENT**—Desk and vault room in the Jewelers' Exchange Building, corner State and Washington streets, Chicago. Fire-proof building. Fire and burglar-proof vault. Suitable for manufacturing jewelers or importers office. Logue & Bard, 104 State st., Chicago.

**FOR SALE**—Stock and fixtures of leading jewelry store in a city of 8,000 inhabitants. One of the best locations in the southern part of Maine. Capital required from \$5,000 to \$6,000. Reason for selling poor health. Address, for particulars, W. L., care Jewelers' Circular.

**FOR SALE**—A well-established jewelry business. Stock consists of watchmakers' tools and materials, watches, jewelry, clocks, spectacles, pocket books, stationery and toys, the whole worth about \$2,500. Best of reasons given for selling. Address E. L. F., care Jewelers' Circular.

**A YOUNG** man desires a situation in a first-class wholesale or retail jewelry house in or out of the city; has had 6 years' experience. Highest reference from former employers. Address, Salesman, care Mr. Henry Olmstead, Secretary Jewelers' Association, 694 Broadway, N. Y.

**GEORGE E. WILKINS**, manufacturer and importer of cutters for watchmakers' use, stem-winding cutters of all the different forms, rounding up cutters of the finest quality, also ratchet cutters. A large stock of second hand and new marine chronometers. No. 21 South Salina street, Syracuse, N. Y.

**A WATCHMAKER**, fully competent, wishes to change his present location about October 1st, 1884. Is 26 years of age and single, with 8 years' experience, has a complete set of tools, American lathe, etc. California or Texas preferred. Is at present with J. W. Forney, Steubenville, O. "Correspondence solicited.

**FOR SALE**—First-class jewelry store in town of 8,000 population and thickly settled country around. Leading store of the place in stock and trade. Will invoice stock and fixtures about \$5,000. Reasons for selling an not a practical jeweler and want to move west. Address C. C., care Jewelers' Circular.

**FACTORY** building to let, in part or whole. Situate 223 West 25th street, bet. 7th and 8th avenues. New building and well lighted. 5 story, 23x82. Arranged to suit tenant. Enquire of B. & W. B. Smith, 220 West 29th street, N. Y.

**FOR SALE**—At a bargain, in the best town in Maryland, a jewelry store, stock and fixtures. Established six years. Plenty of work. Stock between \$3,000 and \$5,000. Would be reduced if desired, and will be sold at a sacrifice. Correspondence solicited. Address G. R. Bowman, P. O. Box 402, Hagerstown, Md.

**WANTED**—Situation in some wholesale jewelry house as salesman, with chance to go on the road, by young man. Have had six years' bench work and salesman in jewelry store and clock house. Can give good Chicago and other references as to my honesty, integrity, &c. Address H. E. B., care Jewelers' Circular.

**FOR SALE**—An old-established jewelry store in a city of 30,000 inhabitants in central Penna. Stock will invoice about \$1,000. Good run of watch work. Splendid chance for an energetic workman without much capital. One of the best locations in the city. Reason for selling death of proprietor. For particulars address E. F. M., care Jewelers' Circular.

**FOR SALE**—Stock and fixtures of a well-established jewelry business. All the work one man can do. No competition. Best market on the D. & B. C. R. R., and in most prosperous farming section of the state. Only 3 miles from the famous summer resort Lake Orion. A rare chance for a man with \$3,000 cash. Could reduce stock if desired. Change of business reason for wanting to sell. Address W. H. Brownell, Oxford, Mich.

**INTERESTING FOR MANUFACTURERS OF CHARMS**—A patent right for sale. Or a capable man of honest and noble character with capital as partner wanted. For a quite new and useful charm which is patented in four countries. Already manufactured and sold in Germany with great success, and of no doubt it will make a great success in the United States. For further particulars, address Hohelsen's Patent Charm, care of Jewelers' Circular.

**TO THE TRADE**—I make a specialty of supplying the Trade with stones for jobbing purposes. Parties having jewelry out of which the stones have been lost, sending their orders by mail or express, will have them promptly attended to. A large stock of cameos, pearls, turquoise, garnets, amethysts, doublets, foil backs, white and colored imitation stones on hand. All kinds of setting done for the Trade. W. Archibald, 73 Nassau street, New York.

**ENGRAVERS ATTENTION**—1000 copies of any monogram or letter, printed on paper, can be transferred lastingly on metal, &c., so it can be engraved exactly like the copy, by a simple method. Engravers who find it difficult to mark out monograms and fancy letters correctly will appreciate this secret. Instructions how to do above and also receipts for the best hard and soft soldering fluids ever made, sent to any jeweler for \$1.00. Address C. C. Heckart, Springfield, Mo.

**FOR SALE**—A good paying jewelry business in a good live city in middle Nebraska. 3,500 inhabitants, 4 good railroads, county seat, and surrounded by a good farming country. Present stock about \$10,000, can be reduced to suit purchaser. A good run of work, enough for 2 men; good prices for everything, competition light, rent low, and the best location in the city; good, nice and clean stock, all staple. There was never a chance better than this for a man who wants to make money in the jewelry business, it will double discount any big city business with the same capital invested. Good reason given for selling out. For other information write to The Leading Jeweler, P. O. Box 99, Columbus, Nebraska. A man who has not got \$4,000 to \$5,000 need not reply.

**BUYERS' DIRECTORY.****NEW YORK.****Assayers and Sweep Smelters.**

**Wundoehl, H.**—Gold and Silver Refiner, Assayer and Sweep Smelter. 21 John Street, N. Y.

**Badges and Medals.**

**Stockwell & Newman**—19 John Street. Manufacturers of Badges, Medals and Presentation Pieces in Gold and Silver. Also Jewelry and Mounters of Diamonds. Designs supplied.

**Band Rings.**

**Knapp, Charles**, 41 Maiden Lane, N. Y. Specialty: Superior Band Rings, also Ring Shanks & Heads for Seal and Diamond Rings.

**Black Onyx Jewelry.**

**Cox & Sedgwick**—Manufacturers of Black Onyx Jewelry, No. 26 John St. New York.

**Lawson, Samuel**—No. 18 John Street. Manufacturer of Black Onyx Jewelry. Coral repaired for the trade. Goods sent on approval to responsible dealers.

**Woglom & Miller**—Manufacturers of (exclusively) Black Onyx Jewelry, 32 & 34 John St., N. Y.

**Blue Enameled Lockets.**

**Bissinger, Philip & Co.**—Importers of Diamonds, Pearls and Precious Stones. Agent for the Bohemian Garnet Goods. Blue Enameled Lockets. 22 John St., N. Y.

**Emrich, I.**—Importer of Blue Enameled Lockets, Ear Drops and all kinds of Enameled Jewelry; also Enamel for Manufacturing purposes. 66 Nassau St., N. Y.

**Hess & Schliesser**—Importers of Diamonds, Fine Jewelry and Novelties in French Goods. Specialties: Gold and Blue Enameled Lockets, Charms and Crosses. 2 John Street.

**Bohemian Garnet Jewelry.**

**Bissinger, Philip & Co.**—Importers of Diamonds, Pearls and Precious Stones. Sole Agent for the Bohemian Garnet Jewelry. Blue Enameled Lockets. 22 John St.

**Emrich, I.**—Importer of Half Pearls and Bohemian Garnet Jewelry. Designs made to order in our European Factory at moderate prices. 66 Nassau St., N. Y.

**Clock Companies.**

**Ansonia Clock Co.**—Manufacturers of every description of Clocks. 11 to 21 Cliff street, New York.

**E. Howard Watch and Clock Co.**—No. 29 Maiden Lane, New York, and 114 Tremont St., Boston.

**Kroeber, F.**—Manufacturer and Dealer in American and French Clocks, No. 14 Cortlandt Street.

**New Haven Clock Co.**—16 and 18 Park Place, N. Y.

**Seth Thomas Clock Co.**—20 Murray Street, N. Y.

**Waterbury Clock Co.**—Manufacturers, No. 10 Courtlandt St., N. Y. and No. 63 Washington St., Chicago, Ills.

**Welch, E. N., Manufacturing Co.**—Manufacturers of American Clocks. No. 6 Warren St.

**Wm. L. Gilbert Clock Co.**—No. 6 Murray Street, Manufacturers of Clocks. Factories, Winsted, Conn.

**Cameo Cutters, Etc.**

**Peiter, Theodore**—Cameo and Intaglio Engraver. Patentee of the Cameo-Intaglio. No. 3 Maiden Lane, New York.

**Charms & Gold Watch Keys.**

**Rupp & Held**—Manufacturing Jewelers, Charms and Gold Watch Keys, with French and English Rachets, a specialty. 15 John St., N. Y.

**Crucibles.**

**Berge, J. & H.**—Established 1850. Importers of Sand Crucibles, Covers, Chemical Porcelain, Glassware, and Jewelers' and Assayers' Supplies. 95 John Street, N. Y.

**Cutlery.**

**Harrison Bros. & Howson**—Manufacturers of Fine Ivory and Pearl Table and Pocket Cutlery, Carvers in Cases; Nutpicks, Nutcracks and goods suitable for the jewelry trade. 126 Chambers Street. W. C. Burkinshaw, Sole Agent.

**Diamond Brokers.**

**Anderson, Otis**—Diamond Merchant and Broker, always ready to pay cash for bargains in Diamonds and Precious Stones, 4 & 6 John Street, N. Y.

**Bernhardt, Richard**—Diamond Broker and Importer, 65 Nassau Street (Room 6), N. Y. Paris, 20, rue des Petites-Écuries.

**Friend S. & Son**—Brokers and dealers in Diamonds 33 John Street, cor. Nassau St. New York.

**Herbert, R. J.**—Diamond Broker and Dealer, 26 Maiden Lane.

**Diamond Importers.**

**Bernhard, A. & Co.**—Importers of Diamonds and Manufacturers of First-class Diamond Jewelry, Diamond Settings for Manufacturing Jewelers. Catalogue of Designs for the Trade free of charge. No. 2 Maiden Lane, New York.

**Bissinger, Philip & Co.**—Importers of Diamonds, Pearls and Precious Stones. Agent for the Bohemian Garnet Goods. Blue Enameled Lockets. No. 22 John St., N. Y.

**Bruhl, D. & M.**—Established in 1848. 14 Maiden Lane, N. Y.; 111 Broad Street, Providence, R. I.; 14 Rue Bleue, Paris.

**Brunswick, S. & Co.**—Importers of Diamonds. 17 Maiden Lane, New York. Paris, Rue Lafayette. Amsterdam, Damstraat.

**Citroen, L. B., & Co.**—Diamonds. 21 John St., N. Y. Cutting Works, 57 & 61 Rapenburgerstraat, Amsterdam. House in Paris, 44 Rue Laffitte.

**Faulkenau, Oppenheimer & Co.**—Manufacturers. Diamonds and Diamond Jewelry. 40 Maiden Lane, N. Y.

**Fera, Henry**—Importer of Diamonds, and Manufacturer of Fine Diamond Jewelry. 4 & 6 John Street, New York. Amsterdam, Holland, 23 Loojersgracht.

**Fox, M. & Co.**—Importers of Diamonds, Rubies, Sapphires and Fancy Gems. No. 1 Maiden Lane, New York

**Hedges, Wm. S. & Co.**—Importers of Diamonds. No. 170 Broadway, corner Maiden Lane.

**Henle Brothers**—Importers of and Wholesale Dealers in Diamonds only. No. 16 Maiden Lane, N. Y. Paris, 20 Rue Laffitte.

**Kuhn, Doerflinger, & Co.**—Manufacturing Jewellers and Importers of Diamonds, 18 John street, New York

**Leberthon, L. M.**—Importer of Diamonds and Manufacturer of Fine Jewelry. 14 John Street, N. Y.

**Miller Bros.**—Importers of Diamonds and Manufacturers of Fine Diamond Jewelry and Mountings.

**Mulford & Bonnet**—Diamond Importers, No. 21 Maiden Lane, N. Y. City.

**Neresheimer, E. Aug. & Co.**—Importer of Diamonds. No. 21 Maiden Lane, New York.

**Randel, Baremore & Billings**—Importers of Diamonds, corner Maiden Lane and Nassau St.

**Saril, S.**—Importer of Diamonds, 182 Broadway, N. Y. Branch of Vve. H. A. Marchand & Frères, 47 Rue Le Peletier, Paris.

**Saunders & Ives.**—Importers of Diamonds and other Precious Stones. No. 26 Maiden Lane.

**Smith, Alfred H. & Co.**—Importers of Diamonds, No. 182 Broadway.

**Tannenbaum, L. & Co.**—Importers of Diamonds and Precious Stones. Steam Lapidary Works. Oriental Stones Cut and Polished a specialty. 65 Nassau St., N. Y.

**Taylor & Brother.**—Importers of Diamonds and Diamond Jewelry. 860 Broadway.

**Wickham, D. H. & Co.**—Importer of Diamonds. No. 31 Holborn Viaduct, London, 24 Maiden Lane, New York.

**Wolff, G. A.**—Importer of Diamonds, Rubies, Sapphires, Pearls, and other Precious Stones, 65 Maiden Lane, New York. 12 Rue de Chateaudun, Paris.

#### Diamond Jewelry.

**Baldwin, Sexton & Peterson**—Importers of Diamonds and Manufacturers of Diamond Jewelry, 692 and 694 Broadway, N. Y.

**Bornemann, Louis.**—Importer of Diamonds and Manufacturer of Rich Diamond Jewelry, 19 John Street, New York.

**Chalumeau, D.**—Diamond Jeweler and Manufacturer of Mountings. Novelties and Artistic Jewelry. No. 3 Maiden Lane, New York.

**Goldsmith, Iogomar & Co.**—Manufacturers of Diamond Mountings and Diamond Jewelry, 61 Nassau Street, New York.

**Goldsmith & Co.**—Manufacturers of Fine Diamond Mountings and Diamond Jewelry. Lace Pins, Ear Rings and Rings a specialty. 49 Maiden Lane, N. Y.

**Hartje, G. & F.**—Manufacturers of Diamond and Fine Jewelry, 39 Union Square, N. Y.

**Haug, John**—Manufacturer of Fine Diamond Mountings, etc. No. 130 Fulton St., N. Y.

**Heller & Bardel.**—Manufacturers of Diamond and Pearl Jewelry, and Dealers in Diamonds, Pearls, &c. 13 John Street.

**Jeanne Brothers.**—Manufacturers of Diamond Mountings & Rich Jewelry. 1 Maiden Lane.

**Lacroix & Verpillier.**—Manufacturers of Fine Gold Jewelry. Diamonds a specialty. 173 Broadway, N. Y.

**Luthy, A. & Co.**—Manufacturers of Fine Diamond Mountings, Lace Pins, Ear Rings, Rings, Knife Edge Bracelets, Hair Ornaments, etc., a Specialty. 35 Ann Street, corner Nassau Street, N. Y.

**Mitchell, Noah**—Manufacturer of Diamond Jewelry and Diamond Mountings. 52 Maiden Lane, New York.

**Nissen, Ludwig & Co.**—Dealers in Diamonds and Manufacturers of Diamond Mountings. No. 51 Nassau Street, New York, near Maiden Lane.

**Rosswog, C. & Son**—Manufacturers of Rich Diamond Goods. Nos. 5 and 7 Maiden Lane, N. Y.

**Scheer, William**—Diamond Jeweler and Manufacturer of Mountings, Novelties in Artistic Jewelry, 21 East 17th St., N. Y.

**Stern, Louis**—Manufacturing Jeweler. Diamond Mountings a Specialty. 8 & 10 John St., N. Y.

**Voelker, C. T.**—Manufacturer of 18-k. Diamond Mountings, Diamond Jewelry and Roller Chain Bracelets. 15 Maiden Lane, New York.

**Waterman & Lehmann.**—Manufacturing Jewelers and Dealers in Diamonds. Diamond Work, and Fine fancy Rings a specialty, any piece of single work made to order. 37 Maiden Lane, N. Y.

#### Diamond and Pearl Setter, &c.

**Danziger, H.**—Diamond and Pearl Setter, 116 Nassau Street, (Second Floor,) Room 6, N. Y.

#### Diamond Cutters.

**Levy, Herman.**—Importer, Cutter and Polisher of Diamonds. 105 Fulton Street, New York.

**Mendes, D. De S.**—Diamond Cutter and Polisher, 113 Nassau St., N. Y. Re-cutting, Repairing and Matching a Specialty.

**Ramgate, Robert H.**—Diamond Cutter and Polisher; Matching and Repairing a specialty. 16 Maiden Lane, New York.

#### Dials, &c.

**New York Dial Co.**—Manufacturers of Fine Watch Dials. Henry Abbott, Agent, No. 4 Maiden Lane, N. Y.

#### Enameled Clock Dials and Figures.

**Caeser Bros.**—Manufacturers of Enameled Clock Dials, also letters and numbers for signs. 230 and 232 East 25th Street, New York.

#### Enamelers, Etc.

**Nutt, J. D.**—Enameler on Gold, Silver, and Copper. Linen finished Buttons and Studs. Enameling in colors. 32 and 34 John Street, New York.

**Orr, J. C.**—Enameler on Fine Jewelry. Enameled in Colors. Linen Finished Buttons and Studs. Band Bracelets. No. 75 Nassau Street, N. Y.

**Orr, William N.**—Enameler on Fine Jewelry. Masonic Jewels and Badges a specialty. Linen Finished Work. 79 Nassau Street, Room 18, New York.

#### Engravers—Stone Seal, Etc.

**Fackner, Edward**—Carver, Engraver and Chaser on Jewelry and Pencil Cases, lettering, &c., 19 John Street.

**Holland & Gosling**—Stone Seal Engravers. Precious Stones inlaid and encrusted with Diamonds. No. 176 Broadway, New York, (fifth floor per elevator). Cameos cut and repaired.

**Knapp, Chas.** Engraver, Die Sinker & Stamper for Jewelry purposes. Ring Shanks & superior Band Rings, 41 Maiden Lane, N. Y.

**Park, Wm.**—The Stone Seal Engraver. Arms, Crests, Monograms, etc., engraved on precious stones, 26 John Street, New York.

**Weston, James F.**—Stone Seal Engraver and inlaid of Precious Stones. Coats of Arms, Masonic, Odd Fellows, and other devices engraved. 32 John Street.

#### Fancy Goods, Clocks, Bronzes, Etc.

**Hinrichs, C. F. A.**—Importer of Fancy Goods, Glassware, China, Clocks, Bronzes, etc. 31 Park Place.

**Le Boutillier & Co.**—Importers of Fancy Goods, Clocks, Bronzes, &c., 33 West 23d Street.

**Straus, L. & Sons**—Importers of Potteries, Faïences, Bisque Figures, and Rich Fancy Goods especially adapted for the Jewelry Trade. 40, 42 and 44 Warren Street, New York.

**Taylor & Bro.**—Importers of French Clocks, Bronzes, etc. 676 Broadway, N. Y.

**Young, J. M. & Co.**—Importers of Fine Parian, Lava, and Bisque Statuary, Bohemian, German and English Fancy Goods, 37 & 39 Murray St., New York.

#### Gold and Silver Cane Heads.

**Cuppia, L. A.**—Importer of Filigree Jewelry and Manufacturer of Silver and Gold Cane Heads and Novelties in Silver and Gold Jewelry. 19 Union Square, N. Y.

**Simons, Bro. & Co.**—Manufacturers of Gold Headed Canes. 611 and 613 Sansom street, Philadelphia.

**Smith, Rest Fenner & Co.**—No. 701 Broadway, Makers of Fine Gold and Silver Headed Canes.

#### Gold and Silver Plating, Etc.

**Bantle, A.**—Gold, Silver and Electro-Plating, 130 Fulton and 89 Nassau Streets, cor. Fulton Street, (Room 36,) N. Y. Watch Case Polishing.

**Jeandheur, F. & Son.**—Gold and Silver Electro Platers & Fire Gilders, coloring Etruscan and Gold Jewelry a specialty. 125 Fulton St.

**Klees & Magrath**—Gold and Silver Electro-Platers. Coloring Etruscan and Gold Jewelry a Specialty. 89 Nassau Street, New York.

#### Gold Chains, Etc.

**Beck, J. & Son,** Manufacturers of Fine Gold Chains and Chain Bracelets, 10 Liberty Place, near Maiden Lane, N. Y.

**Carter, Sloan & Co.**—Manufacturers of Fine Gold Chain, 15 Maiden Lane, New York.

**Edge, W. C. & Co.**—Manufacturers of the Celebrated Woven Fabric Gold Chain, No. 15 John Street.

**Kaufmann Bros.**—Manufacturers of Gold Chains, and Chain Bracelets, 12 First Street; Factory, 331 and 333 Bowery, N. Y.

**Kohn, Alois & Co.**—Manufacturers of Gold Chains. 9 Maiden Lane, N. Y.

**Saxton, Smith & Co.**—Manufacturers of Fine Gold Chain, No. 14 John Street, N. Y.

**Schlag, Chas.**—(Late Nordt & Schlag), Manufacturer of Gold Chains, Chain Bracelets and Fine Jewelry. 177 Broadway, New York. All kinds of Jobbing promptly attended to.

**Smith, W. & Co.**—Manufacturers of Gold and Silver Chains, Jewelry, etc. No. 25 Maiden Lane, N. Y.

#### Gold Pens, Etc.

**Aikin, Lambert & Co.**—Manufacturers of Choice Gold Pens, Cases, Holders, Toothpicks, etc., 23 Maiden Lane, N. Y.

**Fairchild, Leroy C. & Co.**—No. 10 Maiden Lane, New York. Manufacturers of Gold Pens, Pencils, etc.

**Fairchild, Leroy W.**—Manufacturer of Gold Pens, Pencil Cases, Tooth Picks and Novelties in Charms. No. 18 John St., N. Y.

**Foley, John**—Manufacturer of Fine Gold Pens, Pencils and Charms. 2 Astor House, N. Y.

**Gerow, Joseph U.**—Manufacturer of Pencil and Pen Cases for the Jobbing Trade only. No. 44 State Street, (near South Ferry,) Brooklyn, N. Y.

**Hicks, W. S.**—Established 1848. Manufacturer of Fine Gold Pens, Pencil Cases, Tooth Picks, and Charm Novelties of every description. No. 20 Maiden Lane.

**Johnson, E. S. & Co.**—Manufacturers of Gold Pens, Pen Holders and Pencils. Cor. Maiden Lane and Nassau Street, New York.

**Smith, H. M. & Co.**—Manufacturers of Gold Pens and Holders, Tooth Picks, Pencils, etc. Sole Manufacturers of Sprague's Patent Gold Fountain Pen. Importers of Nickel and Silver Watches. 173 Broadway, New York.

#### Gold Rings.

**Barnet Bros.**—Manufacturers of Stone and Seal Rings, 15 John Street, New York. Factory, Newark, N. J.

**Bowden, J. B. & Co.**—Manufacturing Jeweler.—Solid Gold Rings a specialty, 1 Maiden Lane.

**Cable, Geo. W.**—Manufacturing Jeweler. Plain and Band Rings a Specialty. No. 52 Maiden Lane, N. Y.

**Dattelbaum & Friedman**—Manufacturers of Fine Cameo and Seal Rings, all kinds of Fancy Rings and Diamond Mountings. 10 Maiden Lane.

**Ely, W. H.**—Manufacturer of Solid Gold Rings of every description. No. 58 Nassau Street.

**Engelfried, Braun & Weidmann**—Manufacturing Jewelers, 128 Fulton Street corner Nassau, New York. Commercial Building, room 31. Rings a specialty.

**Henrich, R.**—No. 35 Maiden Lane, Manufacturer of Gold Rings; also Patentee and Manufacturer of the Celebrated Self-Sizing Ring

**Hutchison & Huestis**—Makers of Solid Gold Rings. Quality guaranteed. For the Jobbing Trade only. 196 Broadway, N. Y.

**Kroll, H.**—Manufacturing Jeweler. 78 Nassau Street, New York. Specialty: Solid Gold Stone Rings. All kinds of Fine Jewelry made to order, also Repairing for the Trade.

**Müller, H.**—111 Nassau St., N. Y., Manufacturer of Fancy and Seal Rings of every description. Plain Gold and Chased Band Rings in 10, 14 & 18 Kt.

**Ostby & Barton**—Manufacturers of Plain and Engraved Solid Gold Band Rings. Office, 176 Broadway, N. Y. Factory, 80 Clifford Street, Providence, R. I.

**Peckham, Wm. H.**—Manufacturers of Solid Gold Seamless Rings, and Fancy Embossed Rings, Patent Spectacles, Jewelry, etc. No. 4 Liberty Place N. Y.

**Radler, K.**—Manufacturing Jeweler. Gold Rings and Lockets a specialty. No. 179 Broadway, New York.

**Sauter, L.**—No. 1 Maiden Lane, New York, Manufacturer of Stone Rings of every description, as Diamond, Cameo, Onyx Turquoise, etc., Scarf Pins, Scarf Rings, Studs and Buttons.

**Shafer & Douglass.**—Manufacturers of all kinds of Seal, Stone, Turquoise, and fancy rings. No. 7 Maiden Lane, N. Y.

**Thuerner & Church**—Manufacturers of Fine Gold Rings. No. 9 Maiden Lane, N. Y.

**Hair Jewelry.**

**Moutoux, Wm. E. & Co.**—Manufacturers of Fine Hair Mountings in Gold. Grand catalogues for the trade. 81 Nassau St., Rooms 1 and 2. Finest work and lowest prices

**Sauter, L.**—Manufacturer of Fine Gold and Hair Jewelry and Device Work. Pattern Book sent on application. No. 1 Maiden Lane, N. Y.

**Schwencke O.**—Manufacturer of Fine Hair Jewelry Orders from the country promptly attended to. No. 43 Maiden Lane.

**Jewelry Cases, Fancy Boxes, Etc.**

**American Morocco Case Co.**—7 & 9 Bond St., N. Y., make a specialty of Rich Jewelry, Silverware Cases and Improved Trays for Watches, Rings, &c. Patent Watch Blocks to fit all sizes.

**Braun, Chr. E.**—Manufacturer of Fine Jewelry Boxes and Trays for Show Cases and Trunks. No. 62 Chatham Street, New York. Trays for Show Cases and Trunks a Specialty.

**Bricka, C. A. & Co.**—Manufacturers of Morocco Cases for Cutlery, Silverware, Jewelry, etc. Sample Cards and Rolls. Cases in Rosewood, Black Walnut, etc. 52 Nassau Street, New York.

**Dennison Mfg Co.**—Manufacturers of Morocco, Plush and Velvet Jewelry and Silverware cases. New York, Boston, Philadelphia, Chicago, Cincinnati and St. Louis.

**Haensler, Chas. C.**—Manufacturer of Fine Morocco Cases for Jewelry and Silverware. Toilet Boxes, etc. Trays for Show Cases and Windows. 14 John Street, New York.

**Hebbard & Brother**—Manufacturers of Jewelry and Silver Ware Cases, and Fancy Wood Chests for Tea Sets and Flat Ware. 860 Broadway, New York.

**Kohn, Solomon**—Manufacturer of Fine Morocco Cases for Jewelry, Watches, etc. 43 Maiden Lane, New York.

**Lauten, Edw. A. & Co.**—No. 4 Great Jones St., Manufacturers of Fine Velvet, Brocade, Plush and Morocco Boxes, Patent Ring, Ear Ring and Gent's Scarf Pin Trays, Patent Watch and Bracelet Blocks, Window Decorations, etc.

**Loehr & Koerner**—Manufacturers of Morocco, Velvet, Satin, Jewelry, Watches and Silverware Cases, Jewel, Work Boxes, etc., Fancy Trays and Store Fittings to order. 96 Liberty St.

**New York Morocco Case Co.**—Cases for Jewelry, Watches, Silverware. Boxes and Trays for Jewelers' Travelers. Show Cases and Window Fittings. No. 69 Nassau Street, New York.

**Schwarz, N.**—Manufacturer of fine Cases for Jewelry and Silverware. 866 Broadway, New York.

**Welch & Miller**—169 Broadway. Manufacturers of fine Morocco, Velvet, Russia, Brocade and Plush Jewelry Cases. Trays of every description; Jeweler's Cotton and Twine.

**Wiggers & Froelick**—No. 60 Nassau street—Manufacturers of Cases for Jewelry, &c., of every description. Trays for Show-cases, Stands for Show-windows, etc.

**Jewelers' Findings.**

**Dennison Mfg Co.**—Paper Jewelry Boxes, cards, tags, pink and white cotton, etc. etc. New York, Boston, Chicago, Cincinnati, Philadelphia, St. Louis.

**Ettlinger, L., & Sons**—Makers of Cases and Paper Boxes of every description for Jewelers and Silversmiths. Fine Cases and Trays to order a specialty; also Cards, Tags, Cotton, Tissue Paper, &c. 80 Nassau St., N. Y.

**Valier, S. & Co.**—Manufacturers and Dealers in Jewelers' Boxes, Tags, Cards, Paper and Findings. Trays a specialty. Fancy Ornaments for Show Windows. 66 Nassau street, New York.

**Jewelry Manufacturers.**

**Aikin, Lambert & Co.**—Manufacturers General stock of Reliable Jewelry, 23 Maiden Lane.

**Alling, Isaac A. & Co.**—Manufacturers of Fine Gold Jewelry. Specialties: Wire Bracelets, Bangles, American Lever Sleeve Buttons. Bryant Building, Nassau and Liberty Streets, N. Y. Factory, Newark, N. J.

**Baldwin, Sexton & Perterson**—Manufacturers of Rich Jewelry, 692 and 694 Broadway, N. Y.

**Ball, W. H.**—Manufacturer of Gold Jewelry. Bracelets and Bangles of all kinds a specialty. 9 John Street, N. Y.

**Barthman, Straat & Co.**—Manufacturers of Fine Jewelry. Roman Goods, Rings, Diamonds. No. 43 Maiden Lane.

**Bissinger, Philip & Co.**—Importers of Diamonds, Pearls and Precious Stones. Sole Agents for the Bohemian Garnet Jewelry, Blue Enameled Lockets. 22 John St., N. Y.

**Bonner & Abramovitz**—Manufacturers of Diamond Jewelry. Specialty, Ring Mountings. 128 Fulton Street, Room 30, New York.

**Brown, Thos. G. & Sons**—Mfrs of Rich Jewelry Necklaces, Lockets, Bracelets, Sleeve Buttons, etc., 860 Broadway, N. Y.

**Bryant & Bentley**—Manufacturing Jewelers. Rings a specialty. 12 Maiden Lane

**Carter, Sloan & Co.**—Manufacturing Jewelers, 15 Maiden Lane, New York.

**Champenois & Co.**—No. 5 Maiden Lane, manufacturers of Engraved and Enameled Gold goods, in Sets, Ear Knobs, Bracelets, Studs, Lace and Shawl Pins, Jet cluster and Onyx goods, also "Best Lever" Sleeve Buttons.

**Chatellier, Joseph F.**—Manufacturing Jeweler, No. 694 Broadway, N. Y.

**Churchill, Lewis & Co.**—Manufacturers of Fine Jewelry. 692 Broadway, cor. Fourth St., N. Y.

**Cook, George W.**—Manufacturer of Fine Jewelry and Lockets, 191 Broadway (over Mercantile Bank,) N. Y.

**Cottle S. Co.**—Manufacturers of Fine Jewelry. 860 Broadway, N. Y.

**Cox & Sedgwick**—Manufacturers of fine Onyx and Colored Jewelry. 26 John St., New York

**Day & Clark**—Manufacturers of Fine Jewelry, Lace Pins, Ear Rings, Studs, Lockets, &c., 10 Maiden Lane, New York.

**Geoffroy, Arthur R. & Co.**—Manufacturing Jewelers. Novelties in Diamond Goods. No. 23 Maiden Lane, N. Y.

**Greene Wm. C. & Co.**—Goldsmiths; Manufacturers of Rich Sets in Taper Wire Coral. Office, 192 Broadway.

**Griffith, H.**—Manufacturing Jeweler. Gold and Plated Jewelry. Scarf Pins a specialty. Nutry Alley, near Concord St., Brooklyn, N. Y.

**Groeschel & Rosman**—Manufacturers of Fine Jewelry. No. 27 John Street, N. Y.

**Hartmann, P.**—Manufacturer & Importer of Fine Gold, Diamond, and Filigree Silver Jewelry, No. 36 Maiden Lane. P. O. Box 2,454.

**Hedges, A. J. & Co.**—Manufacturing Jewelers, 6 Maiden Lane.

**Henderson & Winter**—Jewelers, No. 15 Maiden Lane, New York. Specialties—Stone, Cameo, Onyx, Amethyst, Topaz, Pearl and Turquoise Rings.

**Hunt & Owen.**—Manufacturing Jewelers. Office 3 Maiden Lane.

**Jandorf, P. & Bro.**—Manufacturing and Wholesale Jewelers—all grades. Prompt Attention to Orders. We issue no catalogue. 196 Broadway, N. Y.

**Kipper, Vogel & Co.**—Manufacturing Jewelers, 17 Maiden Lane, New York.

**Kremetz & Co.**—Manufacturing Jewelers. No. 182 Broadway. N. Y.

**Kuhn, Doerflinger & Co.**—Manufacturers of Enamelled and Roman Band Bracelets, also Fine Lockets Pendants and Lace Pins. 18 John street.

**Miller Bros.**—Manufacturers of Fine Jewelry, Diamond Goods, Sets, Lace Pins, Ear Rings, Scarf Pins, Sleeve Buttons, Studs, etc. 7 Maiden Lane, N. Y.

**Moore & Horton.**—11 Maiden Lane, Manufacturing Jewelers, Rings, Studs, Collars and Sleeve Buttons, Pins, Ear-rings, &c.

**Muhr's, H., Sons.**—Manufacturing Jewelers. Solid Gold and Filled Rings a specialty. Also Manufacturers of the celebrated Crown Filled Watch Case. 16 Maiden Lane, N. Y.

**Mulford & Bonnet**—No. 21 Maiden Lane, New York.

**Owen, G. & S. & Co.**—Manufacturing Jewelers. Office, No. 3 Maiden Lane.

**Richardson, Enos & Co.**—Manufacturers of Fine Gold Jewelry, Gold Chains, Lockets, Crosses and Necklaces. Colored and Etruscan Work. No. 23 Maiden Lane, New York.

**Richardson, J. W. & Co.**—Manufacturers of Jewelry. Masonic and other Emblems. 196 Broadway, N. Y. Manufactory, Providence, R. I.

**Riley, J. A. & Co.**—Manufacturing Jewelers. Etruscan Gold and Roman Bracelets, Lace Pins, Ear Rings, Scarf Pins, Brooch Pins, etc. No. 860 Broadway, N. Y.

**Ripley, Howland & Co.**—Manufacturers of Fine Jewelry and Platinum Tipped Diamond Settings. No. 17 Maiden Lane, N. Y.

**Schwencke, Wm.**—Manufacturing and Jobbing Jeweler. Repairing a specialty. Orders promptly attended to. No. 43 Maiden Lane, N. Y.

**Sexton & Cole**—Manufacturing Jewelers, Colored Gold and Onyx Goods a specialty. No. 30 Maiden Lane.

**Sheafer, W. H. & Co.**—Manufacturing Jewelers, Specialty Bangles and Bracelets, 15 John St., N. Y.

**Stites' Sons, E.**—Manufacturers of Fine Jewelry. No. 14 John Street, N. Y.

**Street, Geo. O. & Sons.**—Established 1837. Makers of Fine Jewelry, strictly first-class goods of our own make. No. 15 John Street, New York.

**Thoma, Ernest**—Manufacturer of Fine Jewelry, Sleeve Buttons, Rings, Ear-rings, &c. No. 173 Broadway, N. Y. Factory, Hackensack, N. J.

**Ward, Thos. M.**—Manufacturer of Fine Jewelry. Diamond Mountings a specialty. No. 25 John Street, N. Y.

**Wienhold, J.**—Manufacturer of Fine Jewelry. Diamond Mountings a Specialty. 24 John St.

**Woglom & Miller**—Manufacturers of Black Onyx Goods exclusively. 32 & 34 John Street, N. Y.

**Jewelry—Rolled Plate.**

**Blackinton, W. & S.**—Manufacturers of the W. & S. B. Rolled Plated Chains. No. 11 Maiden Lane.

**Frick, John & Co.**—Fine Rolled Plate Jewelry of all kinds. Repairing of every description. 21 and 23 Maiden Lane, N. Y.

**Mauran, J. T.**—Manufacturer of Fine Rolled Plate Jewelry, No. 15 Maiden Lane, N. Y.

**Richards, E. Ira & Co.**—Manufacturers of Fine Rolled Plate Jewelry, No. 200 Broadway, N. Y.

**Jewelers' Tools, etc.**

- Fisher, James J.**—Dealer in Watchmakers' and Jewelers' Materials, Files, Tools, Silk Guards, Spectacles, etc. 695 and 697 Broadway, N. Y.
- Friedenthal, A. & Co.**—Importers and jobbers of Watchmakers' and Jewelers' Tools, Materials, etc. 43 Maiden Lane, N. Y.
- Friedlander, R. & L.**—Importers of Watchmakers' Tools and Materials. 65 & 67 Nassau Street. Branch Office, 264 Bowery.
- Koester, C. F.**—Importer and Manufacturer of Fine Tools, Files and Polishing Materials for Jewelers, Watch Case Makers, etc. 33 John St.
- Kurtz, F. P.**—Manufacturer of Jewelers Machinery, Tools, Rolling Mills, Presses, Polishing Lathes, &c. 97 Cliff St., N. Y.
- Levy, Dreyfus & Co.**—Importers and Jobbers of Watchmakers' and Jewelers tools and materials of every description. 11 Maiden Lane, N. Y.
- Reichhelm, E. P. & Co.**—Importers of Jewelers' Tools, Files, etc. Manufacturers of Brushes and Buffing wheels; also Patent Gas Furnaces for Melting, Plating, Enamelling, Annealing, etc. 80 Nassau St., N. Y.

**Lapidaries.**

- Fox, M. & Co.**—Practical Lapidaries, No. 1 Maiden Lane, New York.
- Graham & Co.**—Practical Lapidaries, Cutters and Polishers of all kinds of Precious Stones, Emeralds, Rubies, Sapphires, etc. Miner's Relics Cut, Polished and Mounted. Locket Glasses, 80 Nassau St., N. Y.
- Kordmann & Michel.**—Lapidaries. Dealers in Precious Stones. Cutting and Polishing Rubies, Sapphires and other Gems a specialty. Drilling done promptly. 59 Nassau St., N. Y.

**Masonic Jewelry.**

- Luther, John F.**—79 Nassau Street. Manufacturer of Fine Presentation Jewels for all Societies. Knights Templars, Crosses, Badges, &c.
- Wilkinson, C. B.**—Manufacturing Jeweler, 8 John St., N. Y. Medals, Badges and Masonic Jewelry, a specialty. Designs furnished free upon application.

**Optical Goods.**

- Friedlander, R. & L.**—65 and 67 Nassau Street. Dealers in Optical Goods.

**Opticians.**

- Burbank Manfg Co.**—Manufacturers of Spectacles and Eye Glasses of all descriptions, in gold, silver, etc., 14 Maiden Lane, N. Y.
- DuBois, Geo. W. & Co.**—Importers of Watches and Optical Goods. 36 Maiden Lane, N. Y.
- Levy, Dreyfus & Co.**—Importers of Spectacles and Eye Glasses and Optical Instruments of every description, No. 11 Maiden Lane, N. Y.
- Lorsch, Albert**—Manufacturer of the Patent Accommodating Spectacles and Eye Glasses in Gold, Silver and Steel, and other Optical Goods, 37 Maiden Lane, N. Y.
- Spencer Optical Manufacturing Co.**—Gold, Silver, Steel, Nickel and Plated Spectacles; Gold, Celluloid, Steel, Nickel and Rubber Eye Glass and Opera Glasses. 13 Maiden Lane, N. Y.
- Todd, James W.**—No. 20 Maiden Lane, N. Y. Wholesale Dealer in Optical Goods.

**Paper Boxes.**

- Waterbury Paper and Box Co.**, 27 to 35 Canal St., Waterbury, Conn., Manufacture Jewelers' and Silversmiths' Fine Paper Boxes. Quality guaranteed to be equal to the best made.

**Polishers and Lappers.**

- Klees & Co.**—Late Abels, Polishers and Lappers of Fine Jewelry. 89 Nassau St., Room 17, N. Y.

**Precious Stones, &c.**

- Bishop, Victor & Co.**—33 Maiden Lane, Importers of Precious Stones, Cameos, &c. Also Manufacturers of Coral Jewelry.

**Bissinger, Philip & Co.**—Importer of Diamonds, Pearls and Precious Stones. Agent for the Bohemian Garnet Goods. Blue Enameled Locket. No. 22 John St., N. Y.

**Breidenbach, R. A.**—Importer of Black Onyx, Diamonds, Pearls, Turquoise, Cameos, Sardonyx, Amethysts, Garnets, Topaz, Opals, Rubies, Sapphires, Hematite Balls, Foil Brilliants, Cat's-Eyes, Tiger Eyes, Doublets, Cabinet Specimens, etc. 85 Nassau Street, New York.

**Daue, Wm. & Co.**—Importer of Precious and Imitation Stones. No. 202 Broadway New York.

**Fox, M. & Co.**—Importers of Diamonds and other Precious Stones, No. 1 Maiden Lane, N. Y.

**Gruet, Jules.**—Importer of all Grades of Real and Imitation Stones. 14 John St., N. Y.

**Hahn & Co.**—Importers of Precious Stones, Cameos, Onyx, Pearls, Intaglios, Amethysts, Garnets, etc. 64 Nassau Street, New York.

**Kahn, L. & M. & Co.**—Importers of precious and imitation stones. 10 Maiden Lane, N. Y.

**Kipling, E. E.**—Importer of Precious and Imitation Stones. Manufacturer of the Patent Foil Solid Metal Back Rhine Stone Brilliant. No. 6 Maiden Lane, N. Y.

**Kipling, R. A.**—Precious and Imitation Stones, No. 24 Maiden Lane, N. Y. Manufacturer Cameos, Agates, Onyx, Etc., Oberstein, Germany. Commission Merchant, 49 Rue De L'Echiquier, Paris.

**Lorsch, Albert**—Importer of Precious Stones, 37 Maiden Lane, N. Y.

**Stirn, Max & Bro.**—Importers of Black Onyx, Cameos, Turquoise, Half Pearls, Sardonyx, Amethysts, Topaz, Garnets, Opals, Rubies, Sapphires, Cat's-Eyes, and all other imitation stones, 3 Maiden Lane, New York.

**Safes.**

**Butler, W. H.**—Fire and Burglar Proof Safes, 291 Broadway, N. Y.

**Silverware.**

- Gorham Manufacturing Co.**—Union Square.
- Knowles, J. P. & S. M.**—Manufacturers of Sterling Silverware, 20 Maiden Lane, N. Y. Factory, Providence, R. I.
- Shiebler, Geo. W.**—Manufacturer of Sterling Silverware. No. 8 Liberty Place, near Maiden Lane, N. Y.
- Whiting Manufacturing Co.**—Makers of Sterling Silver Ware. Broadway cor, 4th Street, N. Y.
- Wood & Hughes.**—Manufacturers of Fine Silverware. 16 John Street, N. Y.

**Silver Filigree Jewelry.**

- Cuppia, L. A.**—Manufacturer of Solid Silver Novelties, and Importer of Silver Filigree, 19 Union Square.
- Francesconi, Guido**—Importer of Silver Filigree Jewelry, 196 Broadway, New York.
- Hartmann, P.**—Manufacturer of Silver Filigree Jewelry. 36 Maiden Lane, N. Y.

**Silver Plated Ware.**

- Manhattan Silver Plate Co.**—Manufacturers of Silver Plated Ware. Showrooms, 23 John St. Factory, 301 to 305 East 22d St., cor. 2d Ave. Address all communications to Factory.
- Middletown Plate Co.**—Manufacturers of Superior Electro-Plate. Factories, Middletown, Conn., salesroom, 13 John Street.
- Rogers, Smith & Co.**—Manufacturers of Fine Electro Plated Ware. No. 46 E. 14th St., N. Y.
- Simpson, Hall, Miller & Co.**—Manufacturers of fine Silver-Plated Ware. No. 36 E. 14th Street.
- Schade, Henry.**—Manufacturer of White Metal and Plated Ware. Office, 26 John Street, N. Y. Price list and catalogue furnished on application.
- The Derby Silver Co.**—Manufacturers of Finest Quadruple Silver Plated Ware, Birmingham, Conn. New York office, 25 Maiden Lane.
- Webster, E. G. & Bro.**—Manufacturers of Fine Silver-Plated Ware. Office and warerooms, 14 Maiden Lane, N. Y.

**Show Cases, Etc.**

**Smith, B. & W. B.**—Manufacturers of Patent Improved Dust Proof Show Cases, with Perpendicular Sliding Doors, No. 220 W. 29th St., N. Y.

**Spectacle Case Manufacturers.**

- Bertine, P. D.**—Manufacturer of Spectacle and Eye-Glass Cases. 139 William Street, near Fulton St., New York.
- Koenen, A. & Bro.**—Manufacturers of Leather Spectacle and Eye-Glass Cases for the Jobbing Trade only. 81 Nassau St., N. Y.

**Stem Winding Attachments.**

**Abbott, Henry** Maker of Stem Winding Attachments, No. 4 Maiden Lane, N. Y.

**Swivels and Spring Rings.**

**Schwartz, V. & Co.**—Manufacturers of Gold Swivel and Chain Trimmings. 33 Barclay Street, New York.

**Thermometers, Etc.**

**Tagliabue, Giuseppe.**—manufacturer of Thermometers, Barometers and Hydrometers. Patentee and sole manufacturer of the U. S. Standard Hydrometer. 302 Pearl Street, near Beekman.

**Thimble Manufacturers.**

- Burbank Manufg Co.**—Manufacturers of Gold and Silver Thimbles, 14 Maiden Lane, N. Y.
- Ketcham & McDougall.**—Improved Gold and Silver Thimbles, Bryant Building, N. Y.
- Simons Bro. & Co.**—Manufacturers of Gold and Silver Thimbles, 611 and 613 Sansom Street, Philadelphia.
- Woglom & Miller.**—Sole Agents for the "Prime" Thimbles in Gold and Silver, manufactured by Ezra C. Prime. 34 John Street, N. Y.

**Trunks.**

**Crouch & Fitzgerald**—Manufacturers of Trunks and Articles for Travelers' use. 1 Cortlandt St., 556 Broadway, and 723 Sixth Ave., N. Y.

**Watch Companies.**

- American Watch Co.**—Robbins & Appleton, No. 5 Bond Street, N. Y.
- Illinois Watch Co.**—Springfield, Illinois. 21 Maiden Lane, N. Y. and 71 Washington Street, Chicago, Ills.
- The E. Howard Watch and Clock Co.**—Cor. Maiden Lane and Nassau Street, N. Y.
- Waterbury Watch Co.**—Manufacturers of the Waterbury Watch. Factory, Waterbury. Office, 52 Maiden Lane, N. Y.

**Watch and Chronometer Jeweler.**

- Queen, James.**—Watch and Chronometer Jeweler and Pallet Maker, 78 Nassau Street, room 8. Pivots inserted in Pinions, Balance, Staffs, etc.
- Robert, Henry L.**—Practical Chronometer and Watch Jeweler and Adjuster. 71 Nassau Street. Pallet and Hole Jewels for Chronometer Watches done in the best manner.
- Wennstrom, John.**—Watch, Chronometer and Clock Jeweling, Jewel Gauges, Ruby and Sapphire Draw Plates; Diamond Charged Polishing Stones for Jewel Settings; Pivots inserted in Pinions. 2 Dutch Street, N. Y.

**Watch Importers, Etc.**

- Abry, Chas. Leo**—Importer and Manufacturer of Swiss Watches of all grades. 63 Nassau Street.
- Aikin, Lambert & Co.**—Importers of Watches. Sole Agents for Paul Breton & Chas. Latour, Geneva. A general line of reliable Swiss Watches, Watch Cases, etc. 23 Maiden Lane, N. Y.
- Bartens & Rice**—20 John Street, Importers of Watches and sole agents in the United States for the celebrated Nicole, Nielsen & Co. Watches.
- Cross & Beguelin.**—Importers of Watches, Watch Tools and Materials, dealers in American Watches, No. 21 Maiden Lane, N. Y.
- Droz, Henry E.**—Importer of Watches, and Watch Case Manufacturer. Agent for the "E. Perregaux" Watch, and jobber in American Watches No. 92 Fulton Street, N. Y.
- Freund Max & Co.**—Importers of Watches, Jewelry and Precious Stones, 8 Maiden Lane, N. Y.



**Gagnebin, Chas.**—Importer of all kinds of Swiss, and Dealer in American Watches. 4 Maiden Lane, N. Y. Agent for Ulysse Breting's Fine Chronometers, Chronographs, Anchors, &c.

**Gallet, Julien.**—Importer of Watches. No. 1 Maiden Lane.

**Ginnel, Henry.**—Importer of Watches, Tools and Materials, 31 Maiden Lane, N. Y. P. O. Box 2967

**Hyde's Sons, John E.**—Wholesale Commission Agents, only for Jules Jurgensen, of Copenhagen; Jules Monard, of Geneva; and for other makers of all qualities of Watches, 22 Maiden Lane.

**Keller, L. H. & Co.**—Successors to G. A. Huguenin, Importers of Fine Watch and French Clock Materials, No. 64 Nassau Street, N. Y.

**Mathey Bros. & Mathez.**—Importers of Fine Watches and Sole Agents for the H. L. Matile's Watches. No. 16 Maiden Lane.

**Robert, J. Eugene.**—No. 30 Maiden Lane, New York. Agent for Louis Audemar's celebrated watches.

**Schumann, Chas. W.**—No. 24 John Street, New York. Importer of Fine Diamonds, Watches, etc. Sole Agent in the U. S. for the celebrated "Lange" Dresden Watch.

**Schwob, Adolphe.**—Manufacturer and Importer of Watches, 11 Maiden Lane, N. Y.

**Strasburger, Louis & Co.**—Importers and Makers of Watches of every description, 15 Maiden Lane.

#### Watch Cases.

**Dueber Watch Case Mfg Co.**—Manufacturers of Gold and Silver Watch Cases. Bryant Building, N. Y. Factory, Newport, Ky.

**Fahys, Joseph.**—Manufacturer of Watch Cases and Dealer in American Movements, 38 Maiden Lane.

**Glatz, Chas.**—Manufacturer of Silver Watch Cases. Bryant Building, cor. Nassau and Liberty Sts.

**Keller & Untermeyer.**—Manufacturers of Watch Cases with Raised Gold Ornaments. 9 Maiden Lane, N. Y.

**Ladd Watch Case Co.**—Manufacturers of the Ladd Patent Stiffened Gold Watch Cases, etc., 11 Maiden Lane, N. Y. Factory, 58 Eddy Street, Providence, R. I.

**Martins & Tissot.**—Manufacturers of Gold Watch Cases. No. 15 Maiden Lane, N. Y.

**The Brooklyn Watch Case Co.**—Manufacturers of the celebrated Eagle Case. 40 Maiden Lane.

**Willemin Watch Case Co.**—Makers of Gold Watch Cases. Raised Gold Ornamentation and Jurgensen style of Engine Turning. 109 Sands Street, Brooklyn, N. Y. 16 Maiden Lane, N. Y.

#### Watch and Chronometer Repairers.

**Cerf, B.**—Practical Watchmaker and Repairer, No. 10 John Street, N. Y. Repairing and adjusting of Fine Watches done for the trade. All kinds of escape and stem-winding wheels cut to order.

**Goepp, Frederick A.**—Practical Watchmaker. Repairing of every description for the Trade. 25 Maiden Lane, N. Y. In office of H. Garland, Engraver.

**Heinrich, H. H. & Co.**—Sole Manufacturers of H. H. Heinrich's Patent Auxiliary Balance, and Adjusters and Repairers of Fine Watches and Chronometers. 18 John Street, N. Y.

**La Croix, J. H.**—(Late with Benedict's Time,) Watch and Clock Maker, 21 John Street, N. Y. Clocks of every description Repaired for the Trade.

**Lesperance, Theo.**—Watchmaker and Wheel Cutter. No. 1 Maiden Lane, New York. With Julien Gallet.

#### Watch Case Repairers.

**Feinier, Joseph A.**—Watch Case Maker and General Repairer. Specialty in fine Gold and Silver Cases. Jobbing promptly attended to. Nos. 4 and 6 John St., N. Y.

**Tarbox, Hiram.**—Watch Case Repairing, Springing, Polishing and Engine Turning. 1874 North Fourth Avenue, bet. 176th and 177th Sts., N. Y. Express Packages should be sent to 92 Fulton Street.

#### Watch Glasses, Shades, Etc.

**Brown, Edwin H.**—No. 85 Nassau Street, Imported and Own Manufacture Watch Glasses, Flat, Flat Concave, Concave, Convex and fine Genevas. Fine fitting solicited.

#### Watches, Diamonds and Jewelry.

**Alford, C. G. & Co.**—Manufacturers. General line fine and Reliable Goods, Specialties in Onyx Goods and Chain. 200 Broadway, New York.

**Cohn, J. J.**—Importer and Manufacturer of Whity Jet, Rubber and Pearl goods. Gold and Rolled-plate Jewelry, etc. 12 Maiden Lane, New York.

**Durfey & Reynolds.**—Successors to Durfey & Shiebler, Watches, Diamonds, Jewelry. No. 9 John Street, (up-stairs) New York.

**Friedman, Saml.**—Wholesale Dealer in Watches and Jewelry, 42 Maiden Lane, N. Y.

**Goddard, John M.**—Manufacturing Jeweler,—Seal Rings and Fine Locketts a specialty, No. 3 Maiden Lane, N. Y.

**Greason J. R. & Co.**—Successors to Arthur, Rumrill & Co., 182 Broadway. Manufacturers of Fine Jewelry and Gold Chains, also Diamond Mountings.

**Haskell, H. C.**—Manufacturing Jeweler. Seal Rings a specialty. Special attention to Jobbing of every description. 12 John street.

**Herzog, Louis & Co.**—Importers of Watches, Dealers in Diamonds and Jewelry, 52 Maiden Lane, N. Y.

**Hirsch Bros.**—Dealers in Watches and Diamonds and Manufacturers of Jewelry, No. 23 Maiden Lane, N. Y.

**Jandorf, P. & Bro.**—Importers of Watches and Jewelry, 196 Broadway.

**Kennedy, Frank S.**—Manufacturer and Wholesale Dealer in Jewelry and Gold and Silver Thimbles. No. 13 Maiden Lane, New York.

**Lissauer & Sondheim.**—Wholesale Jewelers and Jobbers in American Watches, No. 12 Maiden Lane, N. Y.

**Marx, Kossuth & Co.**—Importers of Watches and Dealers in Jewelry. 39 Maiden Lane, N. Y.

**May, Henry.**—Importer and Wholesale Dealer in Watches and Diamonds, and Manufacturing Jeweler. 19 John St., N. Y.

**Mayer, B.**—Manufacturer of Fine Jewelry, and Dealer in Watches, 71 Nassau street, cor. John street, New York.

**Myers, S. F. & Co.**—Manufacturing and Wholesale Jewelers—all grades. Importers of Watches. Illustrated Catalogue to the trade. 179 Broadway, N. Y.

**Oppenheimer Bros. & Veith.**—Dealers in Watches and Diamonds, and Manufacturing Jewelers, No. 35 Maiden Lane.

**Scott, J. T. & Co.**—Importers of Watches, and Manufacturers of Jewelry, and Jobbers of all Grades of American Watches, 4 Maiden Lane.

**Smith & Knapp.**—Wholesale Dealers in American and Swiss Watches, Diamonds, Gold and Plated Jewelry and Gold Chain. 182 Broadway, N. Y.

**Steele, J. W.**—Successor to Brainerd, Steele & Co., Manufacturer of Fine Jewelry and Brainerd's Patent Locketts. No. 9 Maiden Lane, N. Y.

**Stern Brothers & Co.**—Importers of Swiss Watches and wholesale dealers in American Watches, &c., 39 Maiden Lane.

**Stern & Stern.**—Dealers in Watches, Jewelry and Diamonds. No. 6 Maiden Lane, N. Y.

**Stites, D. H. & Son.**—Manufacturers of Fine Jewelry, Rolled Plated Goods and Chains, Parisian Diamond Rings, Studs and Earrings a specialty. 41 Maiden Lane, N. Y.

**Strauss, Jacob.**—Full Line of Gold and Plated Jewelry, and Importer of Watches. 18 John Street, New York.

**Thrall, E. A.**—Wholesale Dealer in Watches and Jewelry. No. 1 Maiden Lane, N. Y.

**Trier Bros.**—Importers of Garnet, Whity Jet and Amber Jewelry, Silk Guards, Opera, Field and Marine Glasses, Pearl Card Cases. Also a full line of Gold and Plated Jewelry. 15 Maiden Lane, N. Y.

**Wheeler, Parsons & Hays.**—Manufacturers of Fine Jewelry, Watch Cases, Gold Chains, &c. and Dealer in American and Swiss Watches, No. 2 Maiden Lane, N. Y.

**White, N. H.**—Jobber in American-Waltham Watches and Chronographs. Waltham make of 10-k., 14-k. and 18-k. Gold and Sterling Silver Cases; Filled Gold Cases. 11 Maiden Lane.

#### Watch Tools, etc.

**Keller, L. H. & Co.**—Importers of Watchmakers' and Jewelers' Tools, Materials, etc. 64 Nassau Street, N. Y.

**Zimmern, Henry.**—Importer of Watch Materials, Tools, and Optical Goods, No. 8 Maiden Lane, (first floor.) Sole Agent for A. Hugenin & Gravier. Mainsprings, New York.

#### PHILADELPHIA

**Bennett, Jacob & Son.**—Diamond Setters and Manufacturing Jewelers, 925 Chestnut St.

**Bernard & Co.**—Manufacturers of Fine Roman and Etruscan Jewelry. Designs of every description made to order, 123 & 125 South Eleventh Street, Philadelphia.

**Booz & Co.**—Makers of Fine Gold Watch Cases and Plain Gold Rings, also Dealers in all American Movements, Diamonds, Jewelry, etc. 108 South 8th Street, Philadelphia.

**Conover David F. & Co.**—American Watches, Wholesale Salesroom, Southeast corner 7th and Chestnut Streets, Philadelphia.

**Herold, Chas P.**—Successor to Hildebrandt, Herold & Co., Manufacturing Jeweler and Diamond Setter. Diamonds. 916 Chestnut Street.

**Krieder, Peter L.**—Manufacturer of Sterling Silver Ware. 618 Chestnut Street, Philadelphia.

**McCall & Newman.**—Manufacturing Jewelers. Makers of the Original Gold Crown Filled Rings. No. 625 Arch St., Philadelphia.

**Morgan & Headly.**—Manufacturing Jewelers. Cameo Sets, Gold Sets, Roman Locketts, Rings, Coral Sets and a general line of rich goods. Corner 10th and Chestnut Streets, Philadelphia.

**Muhr's, H. Sons.**—Manufacturing Jewelers. Solid Gold and Filled Rings a specialty. 633 and 635 Chestnut Street, Philadelphia. 1½ Maiden Lane, New York.

**Peters, Reese S.**—Manufacturer of Patent Rolled Plate or Filled Watch Cases, Dealer in American Movements, 308 Chestnut Street, Philadelphia.

**Rosenthal, G. F. C.**—Manufacturing Jeweler and Diamond Setter. Engraving and Designing of Monograms a specialty. No. 917 Sansom Street.

**Scherr, L. A. & Co.**—Wholesale Dealers in Watches Silver-Plated Ware, Spectacles, Fancy Goods, Watch Materials, etc. 726 Chestnut Street.

**Sheafer, W. H. & Co.**—Manufacturing Jewelers. Specialty: Band Brackets. Factory, 612 and 614 Chestnut street, Philadelphia. Office, 15 John street, New York.

**Simons, Brother & Co.**—Manufacturers of Fine Jewelry, Canes, Thimbles, Chains. 611 and 613 Sansom Street.

#### CHICAGO.

**American Watch Company.**—of Waltham, Mass. No. 102 State Street, Chicago.

**Clapp & Davies.**—Wholesale Jewelers, 63 and 65 Washington Street. Catalogue and price list issued to watchmakers and jewelers.

**Dennison Manufacturing Co.**—Manufacturers of Jewelers' Paper Boxes, Morocco Cases, Tags, Cards, Pink and White Cotton, Tissue Papers, Sealing Wax, &c., &c., 102 Madison St., Chicago. Boston, New York, St. Louis, and Philadelphia.

**Gilbert, Wm. L., Clock Co.**—Manufacturers of Clocks, Regulators, and Time Pieces, and Clock Material of every description, 54 and 56 Madison Street, Chicago.

**Giles, Bro. & Co.**—Manufacturers and Jobbers in Watches, all classes of Jewelry, Materials, Clocks, Silver Ware, &c. Illustrated catalogues furnished to dealers on application. 101 & 103 State St.

#### NEWARK.

**Baker & Co.**—Gold, Silver and Platinum Refiners Assayers and Sweep Smelters. 408 New Jersey Railroad Avenue, cor. Murray St., Newark, N. J.

**Diefenthaler Bros. & O'Donnell.**—Manufacturers of Fine Jewelry, Lace Pins, Ear Rings and Patent Spring Bangles a Specialty. 36 Crawford Street, Newark, N. J.

**English & Miller**—Manufacturers of Gold Jewelry, Diamond and Fancy Stone Rings, Roman Lockets, Bangle and Flexible Bracelets, Knife Edge Lace Pins and Sets, Scarf Pins and Link Buttons. 61 and 63 Hamilton St., Newark.

**Felger, F. & F.**—Manufacturing Jewelers. Specialties:—Roman Band Bracelets, Lace Pins, Scarf Pins, Ball and Fancy Ear Rings. No. 477 Washington Street, Newark, N. J.

**Fiedler, Herrman**—Successor to Kunze & Fiedler, Engraver, Die Sinker and Press Tool Maker, 363 Market Street, Opposite Pennsylvania R. R. Depot, Newark, N. J.

**Glorieux, W. L.**—Assayer, Refiner and Sweep Smelter. 13 and 15 Franklin Street, Newark, N. J.

**Hopper & Wilson**—Manufacturers of Fine Jewelry, No. 8 Maple Place, Rear 44 Green St., Newark, N. J.

**Huger & Heitlinger**—Manufacturers to the Jobbing Trade only. Makers of Roman, Stone, Engraved and Enameled Lockets a specialty. Also Sleeve Buttons, Collar Buttons and Studs. 477 Washington Street, Newark, N. J.

**Krippendorf, C. & Schuller, F.**—Machinists and Jewelers' Tool Makers. 19 Greene Street, Newark, N. J. Rolls, Dies, Cutters, and Draw-plates of every Description made and repaired.

**Lelong, L. & Bro.**—Gold and Silver Refiners Assayers and Sweep Smelters, Southwest corner of Halsey and Marshall Streets, Newark, N. J.

**Milne, Alex.**—Manufacturer of Stem-winding Watch Crowns. 19 Ward Street.

**Nesler & Co.**—Manufacturers of 18 Kt. Gold Filled Hoop Ear Rings, Plain, Facet and Engraved, all sizes. 36 Crawford St., Newark, N. J.

**Regad, E. D.**—Lapidary. Specialty—Sardonyx, Black Onyx and Agates. 14 Oliver St., Newark.

#### PROVIDENCE

**Arnold & Webster**—Manufacturers of Solid Gold Engraved Band Rings for the Jobbing Trade. 29 Point Street, Providence, R. I.

**Butts, Geo. F.**—Manufacturing Jeweler. Ladies' and Misses' Solid Gold Drops and Studs a Specialty. 119 Orange Street, Providence, R. I.

**Bradley, R. & Son**—Manufacturers of Solid Gold and Rolled Plate Jewelry. White Stone Goods a Specialty. 227 Eddy Street, Providence, R. I.

**Capron & Co.**—Manufacturers of Jewelry. Engraved Box Bracelets, Bangle Wire Bracelets, Original Lever Collar and Cuff Button. No. 407 Pine Street, Providence, R. I.

**Elmwood Paper Box Co.**—Makers of Jewelers' Cases, Trays, etc. Factory, 54 Greenwich St., Providence, R. I.

**Hamilton, William & Co.**—Manufacturers of Fine Rolled Plated Chains and Patent Band Bracelets. 116 Pine St., Providence, R. I.

**Harrington, J. C.**—Maker of Fine Gold Plated Jewelry. Specialties:—Oval Wire Bangles, Band Bracelets and the Victor Swivel. 129 Eddy St., Providence, R. I.

**Hough, W. S., Jr., & Co.**—Manufacturers of the Hough, Jr., Rolled Plate Lockets, Charms and Pendants. For sale by all first-class Jobbers or Wholesale Jewelers in the United States and Canadas.

**Hutchison & Huestis**—Makers of Solid Gold Rings. Quality guaranteed. For the Jobbing Trade only. 185 Eddy Street, Providence, R. I.

**Irons, Chas. F.**—Manufacturer of Solid Gold Jewelry. Specialty, Emblems, Pins and Charms, Masonic, Odd Fellows, etc. 102 Friendship St.

**Pitts & Hicks**—Manufacturers of the Excelsior Button and Eclipse Lever Button, also a line of White Stone Gold Goods and a fine line of Lace Pins and Drops in Rolled Plate Goods. 120 Dorrance Street, Providence, R. I.

**Taylor, Geo. H. & Co.**—Watchmakers and Wholesale Dealers in Watches, Clocks, Watch and Clock Material, Tools, Spectacles, Eye Glasses, &c. Particular attention given to trade work. 136 Westminster Street (Room 1), Providence, R. I.

#### PAWTUCKET.

**Fuller, Geo. H. & Son**—Jewelers' Findings, Gold, Silver, Gold Plated and Fire Gilt. Pin Stems, Joints, Catches, Split Rings, Chain Hooks and Swivels, Ear Wires, Chain Bars, etc. 99 Exchange Street, Pawtucket, R. I.

#### CINCINNATI.

**Holland, John**—Manufacturer of Gold Pens, Pencils and Pencil Cases, Gold Toothpicks, etc. Nos. 19 and 21 W. 4th St., Cincinnati, Ohio.

**Lodwick & Nolting**—Wholesale Jewelers (exclusively), S. W. cor. Fourth and Walnut Streets, Cincinnati, Ohio.

#### BOSTON.

**Boston Watch Case Co.**, makers of Watch Cases. Especial attention given to Repairing. 1, 3 & 5 Province Court, Boston, Mass.

**Boyce, E. J.**—Manufacturer of Solid Gold Jewelry. Rings a Specialty. 383 Washington St., Boston, Mass.

**Weber, H. & Co.**—Wholesale Jewelers, Importers and Jobbers of Fine Watch Materials, Jewelers' Findings, Tools, etc., Optical Goods and Silk Guards. Agents for Whitcomb, Standard and Stark's Lathes. 424 Washington St., Boston, Mass.

#### BUFFALO.

**Oliver, W. W.**—Manufacturer of Hand and Power Rolling Mills for Jewelers and Silversmiths, 39 Clinton Street, Buffalo, N. Y.

#### CLEVELAND.

**Chandler, J. M. & Co.**—Manufacturers of the Patent Embossed Bracelet and Jobbers in all kinds of Clocks, Watches, Jewelry, Tools, Materials, etc. 185 Superior St., Cleveland, O.

#### LANCASTER.

**Bowman & Musser**—Jobbers in Watches, Clocks, Chains, Fine Tools and Materials. 20 East Chestnut Street, Lancaster, Pa.

#### PITTSBURGH.

**Barrett, G. B., & Co.**—Wholesale Jewelers and Diamond Importers. We carry a line of everything required by the trade. Lowest prices guaranteed. 101 Fifth Avenue, Pittsburgh, Pa.

**Goddard, Hill & Co.**—Wholesale Dealers in American Watches, Jewelry, Silverware, Clocks, Materials, &c., 43 Fifth Avenue, Pittsburgh, Pa.

**Hodge, Slemmons & Co.**—Wholesale Dealers in American and Swiss Watches, Diamonds, Gold and Plated Jewelry, Clock Material, etc. No. 77 Fifth Ave., Pittsburg.

#### NEW BEDFORD.

**Nye, W. F.**—Manufacturer of Watch, Clock and Chronometer Oils, New Bedford, Mass.

**Wheeler, G. B.**—Manufacturer of Watch and Chronometer Oils, New Bedford, Mass.

#### WORCESTER.

**Washburn & Moen Manufacturing Co.**—Makers of Fine Watch Mainsprings, Worcester, Mass. 16 Cliff Street, New York. 107 to 109 Lake Street, Chicago, Ill.

#### WINCHESTER.

**Goodell & Winn**—Manufacturers of American Watch Hands, Winchester, Mass.

#### ALBANY.

**Reiss, Chas.**—31 and 33 So. Pearl Street, Albany, N. Y. Importer of Watch Tools and Material; General Supply; Low Prices. Repairing for the Trade.

#### KEOKUK, IOWA.

**Ayres, T. R. J., & Sons**—Wholesale Jewelers. Watches, Jewelry, Diamonds, Silverware, Clocks, Optical Goods, Tools, Material, &c. at lowest eastern prices. Correspondence solicited.

#### CANADA.

**Ellis, P. W. & Co.**, No. 31 King street, East Toronto, Ontario, Manufacturing Jewelers, Watchmakers, importers and Jobbers of Watchmakers, and Jewelers' Tools, Materials, General Supplies and American Jewelry. Correspondence solicited with manufacturers of Novelties or specialties in American Tools and Jewelry.

GEO. W. DUBOIS.

F. N. NAUMAN.

## GEO. W. DUBOIS & CO.,

IMPORTERS OF

# Watches & Optical Goods.

ALL STYLES AND QUALITIES OF

SPECTACLES AND EYE-GLASSES.

## Longines' Watches and Movements,

The Watches in Gold, Silver and Nickel Cases of New and Handsome Patterns. The Movements fit 18 size Waltham Stem Winding Hunting Cases.

36 Maiden Lane, New York.

ORDERS BY MAIL RECEIVE PROMPT ATTENTION.

## BARNES' No. 4 LATHE,

For the Heavier Work of Jewelers.

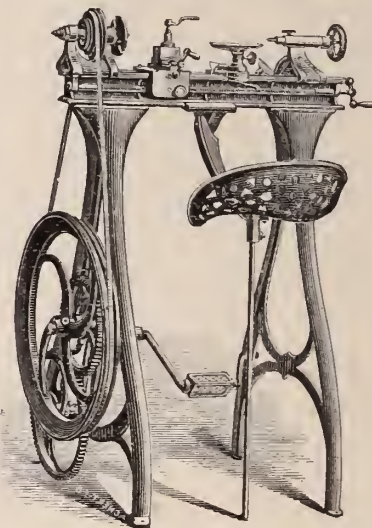

Barnes' Patent Foot and Steam Power Machinery. Complete outfits for Actual Workshop Business. Lathes for wood or metal. Circular Saws, Scroll Saws, Formers, Mortisers, Tenoners, etc. Machines on trial if desired. Descriptive Catalogue and Price List Free.

W. F. & JOHN BARNES,  
2088 Main Street, ROCKFORD, ILL.

## American Lens Mfg. Co.,

MANUFACTURERS OF

# Optical and Object Lenses

OF ALL KINDS.

KATONAH, N. Y.

Spectacle Lenses a Specialty.

**SPECIAL NOTICES.**

**Notices under this Heading, not to exceed Six Lines, \$1.00 each insertion.**

Advertisers having letters addressed in care of this office, must inclose postage for answers forwarded.

**FOR RENT**—Office room to rent at 19 John Street, Stockwell & Newman.

**WANTED**—To correspond with parties in want of watchmaker after Jan. 1st, 1885. B. Jewelers' Circular.

**WANTED**—Situation by a good watch repairer. Best of reference and tools. First-class American lathe. Address A., care John Carver, Chardon, O.

**WANTED**—A young man that has had about two years' experience at the bench and wants to finish the trade. Address Watchmaker, Jewelers' Circular.

**WANTED**—A good jobber and engraver to go to a town of 20,000 inhabitants in the west. Address, with references, Lyon & Hardy, 30 Maiden Lane, N. Y.

**WANTED**—A situation under a first-class workman to complete the jewelers' trade. Good reference given and required. Address J. C., care A. G. Tompkins, Manchester, Mich.

**WANTED**—A situation by a watchmaker and engraver; one who understands the jewelers' business in general; can give the best of references. Address M. W. H., Syracuse, N. Y.

**WATCH MATERIAL FOR SALE**—A large lot of well assorted material, formerly a part of a bankrupt jobber's stock. Cheap for cash if sold in one lot. Address Material, care Jewelers' Circular.

**WANTED**—Situation by a young man, good watchmaker and jobber. Can do letter engraving and competent to act as salesman when required. Address F. L. Reed, care Jewelers' Circular.

**FOR SALE**—Jewelry store in central New York; will net \$15,000 yearly profit on capital of \$1,000—rent cheap. A good chance for an active man. Address Dust Proof, care Jewelers' Circular.

**WANTED**—A situation under a competent watchmaker to finish trade, by a young man of two years' experience. Can give good references. Address E. S. E., No. 27 Boyle St., Allegheny, Pa.

**WANTED IMMEDIATELY**—A first-class watchmaker who can furnish tools and lathes. One who can engrave preferred, and act as salesman if required. Address C. F. Huntington, St. Albans, Vt.

**TO MANUFACTURERS**—An old traveler, with a large acquaintance, now traveling with a special line, desires to arrange to carry a line of novelties on commission. Address A. H. F., care of this office.

**\$2,000** will buy the fixtures, lease (expiring May 1st, 1885), and good will of an old established jewelry store on 6th Ave., N. Y. City. For particulars address to Henderson & Winter, 15 Maiden Lane, N. Y. City.

**WANTED**—The addresses of all traveling dealers in watch materials, etc., to introduce an easily selling and well paying novelty. Communications will oblige H. B., care Editor Jewelers' Circular, 42 Nassau St., N. Y.

**WANTED**—A jeweler who can engrave letters and monograms. A first-rate workman can obtain a good permanent situation in one of the largest southern cities. Apply to Wheeler, Parsons & Hayes, 2 Maiden Lane, N. Y.

**FACTORY building to let**, in part or whole. Situate 223 West 25th street, bet. 7th and 8th avenues. New building and well lighted. 5 story, 23x32. Arranged to suit tenant. Enquire of B. & W. B. Smith, 220 West 29th street, N. Y.

**1,280 ACRES** of Nebraska unimproved land that I want to trade for a general stock of jewelry, dry goods, boots and shoes, or clothing. Will trade all or any part. Address A. M. Day, Wholesale Jeweler, Lincoln, Neb.

**MOSELEY & CO.**, Elgin, Ill., manufacturers of the "Moseley" Lathe, with full line of fixtures and attachments. Designed especially for the watchmaker and repairer. Combining accuracy, durability, convenience and style.

**SITUATION WANTED** as watchmaker by a young man of 21. Four years' experience at watch and jewelry repairing. Can give good reference, and also act as salesman if required. Address Albert Rhein, Jackson, Mich.

**FOR SALE**—No. 1½ hard Whitcomb jewelers' lathe, only been used about one year. Have no use for it as I am out of the trade. Will give a bargain to anyone wishing one. As good as new. Geo. E. Cloyes, Kasson, Dodge Co., Minn.

**FOR SALE**—To close the estate, the stock and fixtures and good will of the old established jewelry store of the late Reed Ferris, at the corner of 5th Ave. and 22d street, N. Y. City. For particulars apply to M. A. Ferris, 237 5th Ave., N. Y. City.

**FOR RENT**—Desk and vault room in the Jewelers' Exchange Building, corner State and Washington streets, Chicago. Fire-proof building. Fire and burglar-proof vault. Suitable for manufacturing jewelers or importers office. Logue & Bard, 104 State St., Chicago.

**SITUATION WANTED** by a young man who has had three years' experience at watch, clock and jewelry repairing, and can engrave. Reference given from present employer. Can come Oct. 1st. Address watch-repairer, box 16, Mt. Morris, Ill. Co., N. Y. Correspondence solicited.

**GEORGE E. WILKINS**, manufacturer and importer of cutters for watchmakers' use, stem-winding cutters of all the different forms, rounding up cutters of the finest quality, also ratchet cutters. A large stock of second hand and new marine chronometers. No. 21 South Salina street, Syracuse, N. Y.

**FOR SALE**—First-class jewelry store in town of 6,000 population and thickly settled country around. Leading store of the place in stock and trade. Will invoice stock and fixtures about \$5,000. Reasons for selling am not a practical jeweler and want to move west. Address C. C., care Jewelers' Circular.

**FOR SALE**—At a bargain, in the best town in Maryland, a jewelry store, stock and fixtures. Established six years. Plenty of work. Stock between \$3,000 and \$5,000. Would be reduced if desired, and will be sold at a sacrifice. Correspondence solicited. Address G. R. Bowman, P. O. Box 402, Hagerstown, Md.

**FOR SALE**—One Bliss Transit, No. 10, perfect order and looks almost well as new; will be sold cheap; can be seen at Wm. Mones & Co., 706 Chestnut Street, Philadelphia, second floor. Also one No. 2 stark lathe, good order, and set of chucks, both sold for want of use. Address correspondence to box 65, Kennett Square, Pa.

**A FIRST-CLASS Watchmaker** with all references from New York and Brooklyn, wishes a good, reliable position west or south-west. Well posted in gaining bargains in jewelry, and a good judge of same; can be of great service to a good employer. Speaks English, German and Danish. Address James Cummins, 242 Clinton St., Brooklyn, N. Y.

**WANTED**—Situation by a good watchmaker, twenty-five years of age, with six years' experience, in some city where he can devote one year's time to fine repairing—chronometers, split seconds, etc. South or west preferred; salary not an object; good references given. None without such an opportunity need address P. O. Box 142, Stoughton, Mass.

**TUBING** of every description drawn to order at short notice. Gold pen, pen and pencil cases, novelties, tooth picks, at lower prices than can be purchased elsewhere. Sample line sent on approval to approved parties. Gold pens re-pointed, repaired, exchanged. Ray Manufacturing Company, salesroom and factories, 94 & 96 Nassau St. and 129, 131 and 133 Fulton St., New York.

**FOR SALE**—Stock and fixtures of a well-established jewelry business. All the work one man can do. No competition. Best market on the D. & B. C. R. R., and in most prosperous farming section of the state. Only 3 miles from the famous summer resort Lake Orion. A rare chance for a man with \$3,000 cash. Could reduce stock if desired. Change of business reason for wanting to sell. Address W. H. Brownell, Oxford, Mich.

**INTERESTING FOR MANUFACTURERS OF CHARMS**—A patent right for sale. Or a capable man of honest and noble character with capital as partner wanted. For a quite new and useful charm which is patented in four countries. Already manufactured and sold in Germany with great success, and of no doubt it will make a great success in the United States. For further particulars, address Hohelsen's Patent Charm, care of Jewelers' Circular.

**TO THE TRADE**—I make a specialty of supplying the Trade with stones for jobbing purposes. Parties having jewelry out of which the stones have been lost, sending their orders by mail or express, will have them promptly attended to. A large stock of cameos, pearls, turquoise, garnets, amethysts, doublets, foil backs, white and colored imitation stones on hand. All kinds of setting done for the Trade. W. Archibald, 73 Nassau street, New York.

**SITUATION WANTED** by competent salesman either to represent some house on road or as salesman to some large firm. Have had seven years' experience in jewelry business; thorough knowledge of repairing French clocks and some experience in repairing watches. Can furnish unexceptional references from my present employer and others as to my capabilities, character, etc. Address W. C. Shaw, care S. P. Hamilton, Bsq., Savannah, Ga.

**FOR SALE**—A good paying jewelry business in a good live city in middle Nebraska. 3,500 inhabitants, 4 good railroads, county seat, and surrounded by a good farming country. Present stock about \$10,000, can be reduced to suit purchaser. A good run of work, enough for 2 men; good prices for everything, competition light, rent low, and the best location in the city; good, nice and clean stock, all staple. There was never a chance better than this for a man who wants to make money in the jewelry business, it will double discount any big city business with the same capital invested. Good reason given for selling out. For other information write to The Leading Jeweler, P. O. Box 99, Columbus, Nebraska. A man who has not got \$4,000 to \$5,000 need not reply.

**FOR SALE**—A well established first-class jewelry store, in a town of over 4,000 inhabitants, situated in the northern part of South Carolina, right in sight of the Blue Ridge Mountains. Good society; good water (both freestone and mineral), and extremely healthful climate. Stock and fixtures will invoice about \$6,000. Will sell one-half if desired, or would prefer to sell one-half interest to a good practical business man as a partner. Handsome store rooms and best central business stand in the town. Large hall on second floor used for music department, and is furnished with pianos and organs in consignment. This house is well established and bears an excellent reputation. Reasons for wanting to make a change, am engaged in other business and need help to manage. Address J. W. McMillan, Spartanburg, S. C.

**ENGRAVERS ATTENTION**—1000 copies of any monogram or letter, printed on paper, can be transferred instantly on metal, &c., so it can be engraved exactly like the copy, by a simple method. Engravers who find it difficult to mark out monograms and fancy letters correctly will appreciate this secret. Instructions how to do above and also receipts for the best hard and soft soldering fluids ever made, sent to any jeweler for \$1.00. Address C. C. Heckart, Springfield, Mo.

**FOR SALE**—Stock of jewelry and musical goods in one of the best country seats in a town in northwestern Ind., established 5 years. Average run of bench work \$55.00 per month during the past year and sales in proportion. Will sell fixtures, including a Hall's fire and burglar proof safe and bulky goods, and reserve rest of stock if preferred. Special agent for the Rockford watches and King's spectacles. A rare chance for some one to step into a good paying business. Reason for selling is to get out of the business. Address W. J. F., care Jewelers' Circular.

**BUYERS' DIRECTORY.****NEW YORK.****Assayers and Sweep Smelters.**

**Wundoehl, H.**—Gold and Silver Refiner, Assayer and Sweep Smelter. 21 John Street, N. Y.

**Badges and Medals.**

**Stockwell & Newman**—19 John Street. Manufacturers of Badges, Medals and Presentation Pieces in Gold and Silver. Also Jewelry and Mounters of Diamonds. Designs supplied.

**Band Rings.**

**Knapp, Charles**, 41 Maiden Lane, N. Y. Specialty: Superior Band Rings, also Ring Shanks & Heads for Seal and Diamond Rings.

**Black Onyx Jewelry.**

**Cox & Sedgwick**—Manufacturers of Black Onyx Jewelry, No. 26 John St. New York.

**Lawson, Samuel**—No. 18 John Street. Manufacturer of Black Onyx Jewelry. Coral repaired for the trade. Goods sent on approval to responsible dealers.

**Woglom & Miller**—Manufacturers of (exclusively) Black Onyx Jewelry, 32 & 34 John St., N. Y.

**Blue Enameled Lockets.**

**Bissinger, Philip & Co.**—Importers of Diamonds, Pearls and Precious Stones. Agent for the Bohemian Garnet Goods. Blue Enameled Lockets. 22 John St., N. Y.

**Emrich, I.**—Importer of Blue Enameled Lockets, Ear Drops and all kinds of Enameled Jewelry; also Enamel for Manufacturing purposes. 66 Nassau St., N. Y.

**Hess & Schliesser**—Importers of Diamonds, Fine Jewelry and Novelties in French Goods. Specialties: Gold and Blue Enameled Lockets, Charms and Crosses. 2 John Street.

**Bohemian Garnet Jewelry.**

**Bissinger, Philip & Co.**—Importers of Diamonds, Pearls and Precious Stones. Sole Agent for the Bohemian Garnet Jewelry. Blue Enameled Lockets. 22 John St.

**Emrich, I.**—Importer of Half Pearls and Bohemian Garnet Jewelry. Designs made to order in our European Factory at moderate prices. 66 Nassau St., N. Y.

**Clock Companies.**

**Ansonia Clock Co.**—Manufacturers of every description of Clocks. 11 to 21 Cliff street, New York.

**E. Howard Watch and Clock Co.**—No. 29 Maiden Lane, New York, and 114 Tremont St., Boston.

**Kroeber, F.**—Manufacturer and Dealer in American and French Clocks, No. 14 Cortlandt Street.

**New Haven Clock Co.**—16 and 18 Park Place, N. Y.

**Seth Thomas Clock Co.**—20 Murray Street, N. Y.

**Waterbury Clock Co.**—Manufacturers, No. 10 Courtlandt St., N. Y. and No. 63 Washington St., Chicago, Ills.

**Welch, E. N., Manufacturing Co.**—Manufacturers of American Clocks. No. 6 Warren St.

**Wm. L. Gilbert Clock Co.**—No. 6 Murray Street, Manufacturers of Clocks. Factories, Winsted, Conn.

**Cameo Cutters, Etc.**

**Peiter, Theodore**—Cameo and Intaglio Engraver. Patentee of the Cameo-Intaglio. No. 3 Maiden Lane, New York.

**Charms & Gold Watch Keys.**

**Rupp & Held.**—Manufacturing Jewelers, Charms and Gold Watch Keys, with French and English Ratchets, a specialty. 15 John St., N. Y.

**Crucibles.**

**Berge, J. & H.**—Established 1850. Importers of Sand Crucibles, Covers, Chemical Porcelain, Glassware, and Jewelers' and Assayers' Supplies. 95 John Street, N. Y.

**Cutlery.**

**Harrison Bros. & Howson.**—Manufacturers of Fine Ivory and Pearl Table and Pocket Cutlery, Carvers in Cases; Nutpicks, Nutcracks and goods suitable for the jewelry trade. 126 Chambers Street. W. C. Burkinshaw, Sole Agent.

**Diamond Brokers.**

**Anderson, Otis.**—Diamond Merchant and Broker, always ready to pay cash for bargains in Diamonds and Precious Stones, 4 & 6 John Street, N. Y.

**Bernhardt, Richard.**—Diamond Broker and Importer, 65 Nassau Street (Room 6), N. Y. Paris, 20, rue des Petites-Écuries.

**Friend S. & Son.**—Brokers and dealers in Diamonds 33 John Street, cor. Nassau St. New York.

**Herbert, R. J.**—Diamond Broker and Dealer. 26 Maiden Lane.

**Diamond Importers.**

**Bernhard, A. & Co.**—Importers of Diamonds and Manufacturers of First-class Diamond Jewelry, Diamond Settings for Manufacturing Jewelers. Catalogue of Designs for the Trade free of charge. No. 2 Maiden Lane, New York.

**Bissinger, Philip & Co.**—Importers of Diamonds, Pearls and Precious Stones. Agent for the Bohemian Garnet Goods. Blue Enameled Locketts. No. 22 John St., N. Y.

**Bruhl, D. & M.**—Established in 1848. 14 Maiden Lane, N. Y.; 111 Broad Street, Providence, R. I.; 14 Rue Bleue, Paris.

**Brunswick, S. & Co.**—Importers of Diamonds. 17 Maiden Lane, New York. Paris, Rue Lafayette. Amsterdam, Damsstraat.

**Citroen, L. B., & Co.**—Diamonds. 21 John St., N. Y. Cutting Works, 57 & 61 Rapenburgerstraat, Amsterdam. House in Paris, 44 Rue Laffitte.

**Faulkenau, Oppenheimer & Co.**—Manufacturers. Diamonds and Diamond Jewelry. 40 Maiden Lane, N. Y.

**Fera, Henry.**—Importer of Diamonds, and Manufacturer of Fine Diamond Jewelry. 4 & 6 John Street, New York. Amsterdam, Holland, 23 Loojersgracht.

**Fox, M. & Co.**—Importers of Diamonds, Rubies, Sapphires and Fancy Gems. No. 1 Maiden Lane, New York.

**Hedges, Wm. S. & Co.**—Importers of Diamonds. No. 170 Broadway, corner Maiden Lane.

**Henle Brothers.**—Importers of and Wholesale Dealers in Diamonds only. No. 16 Maiden Lane, N. Y. Paris, 20 Rue Laffitte.

**Hessels, Anthony.**—Importer and Dealer in all kinds of Precious Stones. Diamond Cutters and Polishers. 45 John Street, N. Y.

**Kuhn, Doerflinger, & Co.**—Manufacturing Jewelers and Importers of Diamonds, 18 John street, New York

**Leberthon, L. M.**—Importer of Diamonds and Manufacturer of Fine Jewelry. 14 John Street, N. Y.

**Miller Bros.**—Importers of Diamonds and Manufacturers of Fine Diamond Jewelry and Mountings.

**Mulford & Bonnet.**—Diamond Importers, No. 21 Maiden Lane, N. Y. City.

**Neresheimer, E. Aug. & Co.**—Importer of Diamonds. No. 21 Maiden Lane, New York.

**Randel, Baremore & Billings.**—Importers of Diamonds, corner Maiden Lane and Nassau St.

**Saril, S.**—Importer of Diamonds, 182 Broadway, N. Y. Branch of Vve. H. A. Marchand & Frères, 47 Rue Le Peletier, Paris.

**Saunders & Ives.**—Importers of Diamonds and other Precious Stones. No. 26 Maiden Lane.

**Smith, Alfred H. & Co.**—Importers of Diamonds, No. 182 Broadway.

**Tannenbaum, L. & Co.**—Importers of Diamonds and Precious Stones. Steam Lapidary Works. Oriental Stones Cut and Polished a specialty. 65 Nassau St., N. Y.

**Taylor & Brother.**—Importers of Diamonds and Diamond Jewelry. 860 Broadway.

**Wickham, D. H. & Co.**—Importer of Diamonds. No. 31 Holborn Viaduct, London, 24 Maiden Lane, New York.

**Wolf, G. A.**—Importer of Diamonds, Rubies, Sapphires, Pearls, and other Precious Stones, 65 Maiden Lane, New York. 12 Rue de Chateaudun, Paris.

**Diamond Jewelry.**

**Baldwin, Sexton & Peterson.**—Importers of Diamonds and Manufacturers of Diamond Jewelry, 692 and 694 Broadway, N. Y.

**Bornemann, Louis.**—Importer of Diamonds and Manufacturer of Rich Diamond Jewelry, 19 John Street, New York.

**Chalumeau, D.**—Diamond Jeweler and Manufacturer of Mountings. Novelties and Artistic Jewelry. No. 3 Maiden Lane, New York.

**Goldsmith, Irgomar & Co.**—Manufacturers of Diamond Mountings and Diamond Jewelry, 61 Nassau Street, New York.

**Goldsmith & Co.**—Manufacturers of Fine Diamond Mountings and Diamond Jewelry. Lace Pins, Ear Rings and Rings a specialty. 49 Maiden Lane, N. Y.

**Hartje, G. & F.**—Manufacturers of Diamond and Fine Jewelry, 39 Union Square, N. Y.

**Haug, John.**—Manufacturer of Fine Diamond Mountings, etc. No. 130 Fulton St., N. Y.

**Heller & Bardel.**—Manufacturers of Diamond and Pearl Jewelry, and Dealers in Diamonds, Pearls, &c. 13 John Street.

**Jeanne Brothers.**—Manufacturers of Diamond Mountings & Rich Jewelry. 1 Maiden Lane.

**Lacroix & Verpillier.**—Manufacturers of Fine Gold Jewelry. Diamonds a specialty. 173 Broadway, N. Y.

**Luthy, A. & Co.**—Manufacturers of Fine Diamond Mountings, Lace Pins, Ear Rings, Rings, Knife Edge Bracelets, Hair Ornaments, etc., a Specialty. 35 Ann Street, corner Nassau Street, N. Y.

**Mitchell, Noah.**—Manufacturer of Diamond Jewelry and Diamond Mountings. 52 Maiden Lane, New York.

**Nissen, Ludwig & Co.**—Dealers in Diamonds and Manufacturers of Diamond Mountings. No. 51 Nassau Street, New York, near Maiden Lane.

**Rosswog, C. & Son.**—Manufacturers of Rich Diamond Goods. Nos. 5 and 7 Maiden Lane, N. Y.

**Scheer, William.**—Diamond Jeweler and Manufacturer of Mountings, Novelties in Artistic Jewelry, 21 East 17th St., N. Y.

**Stern, Louis.**—Manufacturing Jeweler. Diamond Mountings a Specialty. 8 & 10 John St., N. Y.

**Voelker, C. T.**—Manufacturer of 18-k. Diamond Mountings, Diamond Jewelry and Roller Chain Bracelets. 15 Maiden Lane, New York.

**Waterman & Lehmann.**—Manufacturing Jewelers and Dealers in Diamonds. Diamond Work, and Fine fancy Rings a specialty, any piece of single work made to order. 37 Maiden Lane, N. Y.

**Wienhold, J.**—Manufacturer of Fine Jewelry. Diamond Mountings a specialty. 24 John Street.

**Diamond Cutters.**

**Levy, Herman.**—Importer, Cutter and Polisher of Diamonds. 105 Fulton Street, New York.

**Mendes, D. De S.**—Diamond Cutter and Polisher, 113 Nassau St., N. Y. Re-cutting, Repairing and Matching a Specialty.

**Ramsgate, Robert H.**—Diamond Cutter and Polisher; Matching and Repairing a specialty. 16 Maiden Lane, New York.

**Dials, &c.**

**New York Dial Co.**—Manufacturers of Fine Watch Dials. Henry Abbott, Agent, No. 4 Maiden Lane, N. Y.

**Enameled Clock Dials and Figures.**

**Caeser Bros.**—Manufacturers of Enameled Clock Dials, also letters and numbers for signs. 230 and 232 East 25th Street, New York.

**Enamelers, Etc.**

**Nutt, J. D.**—Enameler on Gold, Silver, and Copper. Linen finished Buttons and Studs. Enameling in colors. 32 and 34 John Street, New York.

**Orr, J. C.**—Enameler on Fine Jewelry. Enameled in Colors. Linen Finished Buttons and Studs. Band Bracelets. No. 75 Nassau Street, N. Y.

**Orr, William N.**—Enameler on Fine Jewelry. Masonic Jewels and Badges a specialty. Linen Finished Work. 79 Nassau Street, Room 18, New York.

**Engravers—Stone Seal, Etc.**

**Fackner, Edward.**—Carver, Engraver and Chaser on Jewelry and Pencil Cases, lettering, &c., 19 John Street.

**Holland & Gosling.**—Stone Seal Engravers. Precious Stones inlaid and encrusted with Diamonds. No. 176 Broadway, New York, (fifth floor per elevator). Cameos cut and repaired.

**Knapp, Chas.**—Engraver, Die Sinker & Stamper for Jewelry purposes. Ring Shanks & superior Band rings, 41 Maiden Lane, N. Y.

**Park, Wm.**—The Stone Seal Engraver. Arms, Crests, Monograms, etc., engraved on precious stones. 26 John Street, New York.

**Weston, James F.**—Stone Seal Engraver and cruster of Precious Stones. Coats of Arms, Masonic, Odd Fellows, and other devices engraved. 32 John Street.

**Fancy Goods, Clocks, Bronzes, Etc.**

**Hinrichs, C. F. A.**—Importer of Fancy Goods, Glassware, China, Clocks, Bronzes, etc. 31 Park Place.

**Le Boutillier & Co.**—Importers of Fancy Goods, Clocks, Bronzes, &c., 33 West 23d Street.

**Straus, L. & Sons.**—Importers of Potteries, Faïences, Bisque Figures and Rich Fancy Goods especially adapted for the Jewelry Trade. 40, 42 and 44 Warren Street, New York.

**Taylor & Bro.**—Importers of French Clocks, Bronzes, etc. 676 Broadway, N. Y.

**Young, J. M. & Co.**—Importers of Fine Parian, Lava, and Bisque Statuary, Bohemian, German and English Fancy Goods, 37 & 39 Murray St., New York.

**Gold and Silver Cane Heads.**

**Cuppia, L. A.**—Importer of Filigree Jewelry and Manufacturer of Silver and Gold Cane Heads and Novelties in Silver and Gold Jewelry. 19 Union Square, N. Y.

**Simons, Bro. & Co.**—Manufacturers of Gold Headed Canes. 611 and 613 Sansom street, Philadelphia.

**Smith, Rest Fenner & Co.**—No. 701 Broadway, Makers of Fine Gold and Silver Headed Canes.

**Gold and Silver Plating, Etc.**

**Bantle, A.**—Gold, Silver and Electro-Plating, 130 Fulton and 89 Nassau Streets, cor. Fulton Street, (Room 36,) N. Y. Watch Case Polishing.

**Jeandheur, F. & Son.**—Gold and Silver Electro Platers & Fire Gilders, coloring Etruscan and Gold Jewelry a specialty. 125 Fulton St.

**Klees & Magrath.**—Gold and Silver Electro-Platers. Coloring Etruscan and Gold Jewelry a Specialty. 89 Nassau Street, New York.

**Gold Chains, Etc.**

**Beck, J. & Son.**—Manufacturers of Fine Gold Chains and Chain Bracelets, 10 Liberty Place, near Maiden Lane, N. Y.

**Carter, Sloan & Co.**—Manufacturers of Fine Gold Chain, 15 Maiden Lane, New York.

**Edge, W. C. & Co.**—Manufacturers of the Celebrated Woven Fabric Gold Chain, No. 15 John Street.

**Kaufmann Bros.**—Manufacturers of Gold Chains, and Chain Bracelets, 12 First Street; Factory, 331 and 333 Bowery, N. Y.

**Kohn, Alois & Co.**—Manufacturers of Gold Chains. 9 Maiden Lane, N. Y.

**Saxton, Smith & Co.**—Manufacturers of Fine Gold Chain, No. 14 John Street, N. Y.

**Schlag, Chas.**—(Late Nordt & Schlag), Manufacturer of Gold Chains, Chain Bracelets and Fine Jewelry. 177 Broadway, New York. All kinds of Jobbing promptly attended to.

**Smith, W. & Co.**—Manufacturers of Gold and Silver Chains, Jewelry, etc. No. 25 Maiden Lane, N. Y.

**Gold Pens, Etc.**

- Aikin, Lambert & Co.**—Manufacturers of Choice Gold Pens, Cases, Holders, Toothpicks, etc., 23 Maiden Lane, N. Y.
- Fairchild, Leroy C. & Co.**—No. 10 Maiden Lane, New York. Manufacturers of Gold Pens, Pencils, etc.
- Fairchild, Leroy W.**—Manufacturer of Gold Pens, Pencil Cases, Tooth Picks and Novelties in Charms. No. 18 John St., N. Y.
- Foley, John**—Manufacturer of Fine Gold Pens, Pencils and Charms. 2 Astor House, N. Y.
- Hicks, W. S.**—Established 1848. Manufacturer of Fine Gold Pens, Pencil Cases, Tooth Picks, and Charm Novelties of every description. No. 20 Maiden Lane.
- Johnson, E. S. & Co.**—Manufacturers of Gold Pens, Pen Holders and Pencils. Cor. Maiden Lane and Nassau Street, New York.
- Smith, H. M. & Co.**—Manufacturers of Gold Pens and Holders, Tooth Picks, Pencils, etc. Sole Manufacturers of Sprague's Patent Gold Fountain Pen. Importers of Nickel and Silver Watches. 173 Broadway, New York.

**Gold Rings.**

- Barnet Bros.**—Manufacturers of Stone and Seal Rings, 15 John Street, New York. Factory, Newark, N. J.
- Bowden, J. B. & Co.**—Manufacturing Jeweler.—Solid Gold Rings a specialty, 1 Maiden Lane.
- Cable, Geo. W.**—Manufacturing Jeweler. Plain and Band Rings a Specialty. No. 52 Maiden Lane, N. Y.
- Dattelbaum & Friedman**—Manufacturers of Fine Cameo and Seal Rings, all kinds of Fancy Rings and Diamond Mountings. 10 Maiden Lane.
- Ely, W. H.**—Manufacturer of Solid Gold Rings of every description. No. 58 Nassau Street.
- Engelfried, Braun & Weidmann**—Manufacturing Jewelers, 128 Fulton Street corner Nassau, New York. Commercial Building, room 31. Rings a specialty.
- Henrich, R.**—No. 35 Maiden Lane, Manufacturer of Gold Rings; also Patentee and Manufacturer of the Celebrated Self-Sizing Ring
- Hutchison & Huestis**—Makers of Solid Gold Rings. Quality guaranteed. For the Jobbing Trade only. 196 Broadway, N. Y.
- Kroll, H.**—Manufacturing Jeweler. 78 Nassau Street, New York. Specialty: Solid Gold Stone Rings. All kinds of Fine Jewelry made to order, also Repairing for the Trade.
- Müller, H.**—111 Nassau St., N. Y., Manufacturer of Fancy and Seal Rings of every description. Plain Gold and Chased Band Rings in 10, 14 & 18 Kt.
- Ostby & Barton**—Manufacturers of Plain and Engraved Solid Gold Band Rings. Office, 176 Broadway, N. Y. Factory, 80 Clifford Street, Providence, R. I.
- Peckham, Wm. H.**—Manufacturers of Solid Gold Seamless Rings and Fancy Embossed Rings, Patent Spectacles, Jewelry, etc. No. 4 Liberty Place N. Y.
- Radler, K.**—Manufacturing Jeweler. Gold Rings and Locketts a specialty. No. 179 Broadway, New York.
- Sauter, L.**—No. 1 Maiden Lane, New York, Manufacturer of Stone Rings of every description, as Diamond, Cameo, Onyx Turquoise, etc., Scarf Pins, Scarf Rings, Studs and Buttons.
- Shafer & Douglass.**—Manufacturers of all kinds of Seal, Stone, Turquoise, and fancy rings. No. 7 Maiden Lane, N. Y.
- Thurner & Church**—Manufacturers of Fine Gold Rings. No. 9 Maiden Lane, N. Y.

**Hair Jewelry.**

- Moutoux, Wm. E. & Co.**—Manufacturers of Fine Hair Mountings in Gold. Grand catalogues for the trade. 81 Nassau St., Rooms 1 and 2. Finest work and lowest prices
- Sauter, L.**—Manufacturer of Fine Gold and Hair Jewelry and Device Work. Pattern Book sent on application. No. 1 Maiden Lane, N. Y.
- Schwencke O.**—Manufacturer of Fine Hair Jewelry Orders from the country promptly attended to. No. 43 Maiden Lane.

**Jewelry Cases, Fancy Boxes, Etc.**

- American Morocco Case Co.**—7 & 9 Bond St., N. Y., make a specialty of Rich Jewelry, Silverware Cases and Improved Trays for Watches, Rings, &c. Patent Watch Blocks to fit all sizes.

- Braun, Chr. E.**—Manufacturer of Fine Jewelry Boxes and Trays for Show Cases and Trunks. No. 62 Chatham Street, New York. Trays for Show Cases and Trunks a Specialty.
- Bricka, C. A. & Co.**—Manufacturers of Morocco Cases for Cutlery, Silverware, Jewelry, etc. Sample Cards and Rolls. Cases in Rosewood, Black Walnut, etc. 52 Nassau Street, New York.
- Dennison Mfg Co.**—Manufacturers of Morocco, Plush and Velvet Jewelry and Silverware cases. New York, Boston, Philadelphia, Chicago, Cincinnati and St. Louis.
- Haensler, Chas. C.**—Manufacturer of Fine Morocco Cases for Jewelry and Silverware. Toilet Boxes, etc. Trays for Show Cases and Windows. 14 John Street, New York.
- Hebbard & Brother**—Manufacturers of Jewelry and Silver Ware Cases, and Fancy Wood Chests for Tea Sets and Flat Ware. 860 Broadway, New York.
- Kohn, Solomon**—Manufacturer of Fine Morocco Cases for Jewelry, Watches, etc. 43 Maiden Lane, New York.
- Lauten, Edw. A. & Co.**—No. 4 Great Jones St., Manufacturers of Fine Velvet, Brocade, Plush and Morocco Boxes, Patent Ring, Ear Ring and Gent's Scarf Pin Trays, Patent Watch and Bracelet Blocks, Window Decorations, etc.
- Loehr & Koerner**—Manufacturers of Morocco, Velvet, Satin, Jewelry, Watches and Silverware Cases, Jewel, Work Boxes, etc., Fancy Trays and Store Fittings to order. 96 Liberty St.
- New York Morocco Case Co.**—Cases for Jewelry, Watches, Silverware. Boxes and Trays for Jewelers' Travelers. Show Cases and Window Fittings. No. 69 Nassau Street, New York.
- Schwarz, N.**—Manufacturer of fine Cases for Jewelry and Silverware. 866 Broadway, New York.
- Welch & Miller**—169 Broadway. Manufacturers of fine Morocco, Velvet, Russia, Brocade and Plush Jewelry Cases. Trays of every description; Jeweler's Cotton and Twine.
- Wiggers & Froelick**—No. 60 Nassau street—Manufacturers of Cases for Jewelry, &c., of every description. Trays for Show-cases, Stands for Show-windows, etc.

**Jewelers' Findings.**

- Dennison Mfg Co.**—Paper Jewelry Boxes, cards, tags, pink and white cotton, etc. etc. New York, Boston, Chicago, Cincinnati, Philadelphia, St. Louis.
- Ettlinger, L. & Sons**—Makers of Cases and Paper Boxes of every description for Jewelers and Silversmiths. Fine Cases and Trays to order a specialty; also Cards, Tags, Cotton, Tissue Paper, &c. 80 Nassau St., N. Y.
- Valfer, S. & Co.**—Manufacturers and Dealers in Jewelers' Boxes, Tags, Cards, Paper and Findings. Trays a specialty. Fancy Ornaments for Show Windows. 66 Nassau street, New York.

**Jewelry Manufacturers.**

- Aikin, Lambert & Co.**—Manufacturers General stock of Reliable Jewelry, 23 Maiden Lane.
- Alling, Isaac A. & Co.**—Manufacturers of Fine Gold Jewelry. Specialties: Wire Bracelets, Bangles, American Lever Sleeve Buttons, Bryant Building, Nassau and Liberty Streets, N. Y. Factory, Newark, N. J.
- Baldwin, Sexton & Perterson**—Manufacturers of Rich Jewelry, 692 and 694 Broadway, N. Y.
- Ball, W. H. & Co.**—Manufacturers of Gold Jewelry. Bracelets and Bangles of all kinds a specialty. 9 John Street, N. Y.
- Barthman, Straat & Co.**—Manufacturers of Fine Jewelry. Roman Goods, Rings, Diamonds. No. 43 Maiden Lane.
- Bissinger, Philip & Co.**—Importers of Diamonds, Pearls and Precious Stones. Sole Agents for the Bohemian Garnet Jewelry, Blue Enameled Locketts. 22 John St., N. Y.
- Bonner & Abramovitz**—Manufacturers of Diamond Jewelry. Specialty, Ring Mountings. 128 Fulton Street, Room 30, New York.
- Brown, Thos. G. & Sons**—Man'rs of Rich Jewelry Necklaces, Locketts, Bracelets, Sleeve Buttons, etc., 860 Broadway, N. Y.
- Bryant & Bentley**—Manufacturing Jewelers. Rings a specialty. 12 Maiden Lane
- Carter, Sloan & Co.**—Manufacturing Jewelers, 15 Maiden Lane, New York.

- Champenois & Co.**—No. 5 Maiden Lane, manufacturers of Engraved and Enameled Gold goods, in Sets, Ear Knobs, Bracelets, Studs, Lace and Shawl Pins, Jet cluster and Onyx goods, also "Best Lever" Sleeve Buttons.
- Chatellier, Joseph F.**—Manufacturing Jeweler, No. 694 Broadway, N. Y.
- Churchill, Lewis & Co.**—Manufacturers of Fine Jewelry. 692 Broadway, cor. Fourth St., N. Y.
- Cook, George W.**—Manufacturer of Fine Jewelry and Locketts, 191 Broadway (over Mercantile Bank,) N. Y.
- Cottle S. Co.**—Manufacturers of Fine Jewelry. 860 Broadway, N. Y.
- Cox & Sedgwick**—Manufacturers of fine Onyx and Colored Jewelry. 26 John St., New York
- Day & Clark**—Manufacturers of Fine Jewelry, Lace Pins, Ear Rings, Studs, Locketts, &c., 10 Maiden Lane, New York.
- Geoffroy, Arthur R. & Co.**—Manufacturing Jewelers. Novelties in Diamond Goods. No. 23 Maiden Lane, N. Y.
- Greene Wm. C. & Co.**—Goldsmiths; Manufacturers of Rich Sets in Taper Wire Coral. Office, 192 Broadway.
- Griffith, H.**—Manufacturing Jeweler. Gold and Plated Jewelry. Scarf Pins a specialty. Nutry Alley, near Concord St., Brooklyn, N. Y.
- Groeschel & Rosman**—Manufacturers of Fine Jewelry. No. 27 John Street, N. Y.
- Hartmann, P.**—Manufacturer & Importer of Fine Gold, Diamond, and Filigree Silver Jewelry, No. 36 Maiden Lane. P. O. Box 2,454.
- Hedges, A. J. & Co.**—Manufacturing Jewelers, 6 Maiden Lane.
- Henderson & Winter**—Jewelers, No. 15 Maiden Lane, New York. Specialties—Stone, Cameo, Onyx, Amethyst, Topaz, Pearl and Turquoise Rings.
- Hunt & Owen.**—Manufacturing Jewelers. Office 3 Maiden Lane.
- Jandorf, P. & Bro.**—Manufacturing and Wholesale Jewelers—all grades. Prompt Attention to Orders. We issue no catalogue. 196 Broadway, N. Y.
- Kipper, Vogel & Co.**—Manufacturing Jewelers, 17 Maiden Lane, New York.
- Kremetz & Co.**—Manufacturing Jewelers, No. 182 Broadway, N. Y.
- Kuhn, Doerflinger & Co.**—Manufacturers of Enameled and Roman Band Bracelets, also Fine Locketts Pendants and Lace Pins. 18 John street.
- Miller Bros.**—Manufacturers of Fine Jewelry, Diamond Goods, Sets, Lace Pins, Ear Rings, Scarf Pins, Sleeve Buttons, Studs, etc. 7 Maiden Lane, N. Y.
- Moore & Horton.**—11 Maiden Lane, Manufacturing Jewelers, Rings, Studs, Collars and Sleeve Buttons, Pins, Ear-rings, &c.
- Muhr's, H., Sons.**—Manufacturing Jewelers. Solid Gold and Filled Rings a specialty. Also Manufacturers of the celebrated Crown Filled Watch Case. 16 Maiden Lane, N. Y.
- Mulford & Bonnet**—No. 21 Maiden Lane, New York.
- Owen, G. & S. & Co.**—Manufacturing Jewelers. Office, No. 3 Maiden Lane.
- Richardson, Enos & Co.**—Manufacturers of Fine Gold Jewelry, Gold Chains, Locketts, Crosses and Necklaces. Colored and Etruscan Work. No. 23 Maiden Lane, New York.
- Richardson, J. W. & Co.**—Manufacturers of Jewelry. Masonic and other Emblems. 196 Broadway, N. Y. Manufactory, Providence, R. I.
- Riley, J. A. & Co.**—Manufacturing Jewelers. Etruscan Gold and Roman Bracelets, Lace Pins, Ear Rings, Scarf Pins, Brooch Pins, etc. No. 860 Broadway, N. Y.
- Ripley, Howland & Co.**—Manufacturers of Fine Jewelry and Platinum Tipped Diamond Settings. No. 17 Maiden Lane, N. Y.
- Schwencke, Wm.**—Manufacturing and Jobbing Jeweler. Repairing a specialty. Orders promptly attended to. No. 43 Maiden Lane, N. Y.
- Sexton & Cole**—Manufacturing Jewelers, Colored Gold and Onyx Goods a specialty. No. 30 Maiden Lane.
- Sheafer, W. H. & Co.**—Manufacturing Jewelers, Specialty Bangles and Bracelets, 15 John St., N. Y.
- Stites' Sons, E.**—Manufacturers of Fine Jewelry. No. 14 John Street, N. Y.

**Street, Geo. O. & Sons.**—Established 1837. Makers of Fine Jewelry, strictly first-class goods of our own make. No. 15 John Street, New York.

**Thoma, Ernest**—Manufacturer of Fine Jewelry, Sleeve Buttons, Rings, Ear-rings, &c. No. 173 Broadway, N. Y. Factory, Hackensack, N. J.

**Ward, Thos. M.**—Manufacturer of Fine Jewelry. Diamond Mountings a specialty. No. 25 John Street, N. Y.

**Wienhold, J.**—Manufacturer of Fine Jewelry. Diamond Mountings a Specialty. 24 John St.

**Woglom & Miller**—Manufacturers of Black Onyx Goods exclusively. 32 & 34 John Street, N. Y.

#### Jewelry—Rolled Plate.

**Blackinton, W. & S.**—Manufacturers of the W. & S. B. Rolled Plated Chains. No. 11 Maiden Lane.

**Frick, John & Co.**—Fine Rolled Plate Jewelry of all kinds. Repairing of every description. 21 and 23 Maiden Lane, N. Y.

**Mauran, J. T.**—Manufacturer of Fine Rolled Plate Jewelry, No. 15 Maiden Lane, N. Y.

**Richards, E. Ira & Co.**—Manufacturers of Fine Rolled Plate Jewelry, No. 200 Broadway, N. Y.

#### Jewelers' Tools, etc.

**Fisher, James J.**—Dealer in Watchmakers' and Jewelers' Materials, Files, Tools, Silk Guards, Spectacles, etc. 695 and 697 Broadway, N. Y.

**Friedenthal, A. & Co.**—Importers and jobbers of Watchmakers' and Jewelers' Tools, Materials, etc. 43 Maiden Lane, N. Y.

**Friedlander, R. & L.**—Importers of Watchmakers' Tools and Materials. 65 & 67 Nassau Street. Branch Office, 264 Bowery.

**Koester, C. F.**—Importer and Manufacturer of Fine Tools, Files and Polishing Materials for Jewelers, Watch Case Makers, etc. 33 John St.

**Kurtz, F. P.**—Manufacturer of Jewelers Machinery, Tools, Rolling Mills, Presses, Polishing Lathes, &c. 97 Cliff St., N. Y.

**Levy, Dreyfus & Co.**—Importers and Jobbers of Watchmakers' and Jewelers tools and materials of every description. 11 Maiden Lane, N. Y.

**Reichhelm, E. P. & Co.**—Importers of Jewelers' Tools, Files, etc. Manufacturers of Brushes and Buffing wheels; also Patent Gas Furnaces for Melting, Plating, Enamelling, Annealing, etc. 80 Nassau St., N. Y.

#### Lapidaries.

**Fox, M. & Co.**—Practical Lapidaries, No. 1 Maiden Lane, New York.

**Graham & Co.**—Practical Lapidaries, Cutters and Polishers of all kinds of Precious Stones, Emeralds, Rubies, Sapphires, etc. Miner's Relics Cut, Polished and Mounted. Locket Glasses, 80 Nassau St., N. Y.

**Kordmann & Michel.**—Lapidaries. Dealers in Precious Stones. Cutting and Polishing Rubies, Sapphires and other Gems a specialty. Drilling done promptly. 59 Nassau St., N. Y.

#### Masonic Jewelry.

**Luther, John F.**—79 Nassau Street. Manufacturer of Fine Presentation Jewels for all Societies. Knights Templars, Crosses, Badges, &c.

**Wilkinson, C. B.**—Manufacturing Jeweler, 8 John St., N. Y. Medals, Badges and Masonic Jewelry, a specialty. Designs furnished free upon application.

#### Optical Goods.

**Friedlander, R. & L.**—65 and 67 Nassau Street. Dealers in Optical Goods.

#### Opticians.

**Burbank Manfg Co.**—Manufacturers of Spectacles and Eye Glasses of all descriptions, in gold, silver, etc., 14 Maiden Lane, N. Y.

**DuBois, Geo. W. & Co.**—Importers of Watches and Optical Goods. 36 Maiden Lane, N. Y.

**Levy, Dreyfus & Co.**—Importers of Spectacles and Eye Glasses and Optical Instruments of every description, No. 11 Maiden Lane, N. Y.

**Lorsch, Albert**—Manufacturer of the Patent Accommodating Spectacles and Eye Glasses in Gold, Silver and Steel, and other Optical Goods, 37 Maiden Lane, N. Y.

**Spencer Optical Manufacturing Co.**—Gold, Silver, Steel, Nickel and Plated Spectacles; Gold, Celluloid, Steel, Nickel and Rubber Eye Glass and Opera Glasses. 13 Maiden Lane, N. Y.

**Todd, James W.**—No. 20 Maiden Lane, N. Y. Wholesale Dealer in Optical Goods.

#### Paper Boxes.

**Waterbury Paper and Box Co.**, 27 to 35 Canal St., Waterbury, Conn., Manufacture Jewelers' and Silversmiths' Fine Paper Boxes. Quality guaranteed to be equal to the best made.

#### Polishers and Lappers.

**Klees & Co.**—Late Abels, Polishers and Lappers of Fine Jewelry. 89 Nassau St., Room 17, N. Y.

#### Precious Stones, &c.

**Bishop, Victor & Co.**—33 Maiden Lane, Importers of Precious Stones, Cameos, &c. Also Manufacturers of Coral Jewelry.

**Bissinger, Philip & Co.**—Importer of Diamonds, Pearls and Precious Stones. Agent for the Bohemian Garnet Goods. Blue Enameled Lockets. No. 22 John St., N. Y.

**Breidenbach, R. A.**—Importer of Black Onyx, Diamonds, Pearls, Turquoise, Cameos, Sardonyx, Amethysts, Garnets, Topaz, Opals, Rubies, Sapphires, Hematite Balls, Foil Brilliants, Cat's-Eyes, Tiger Eyes, Doublets, Cabinet Specimens, etc. 85 Nassau Street, New York.

**Daue, Wm. & Co.**—Importer of Precious and Imitation Stones. No. 20 Broadway New York.

**Fox, M. & Co.**—Importers of Diamonds and other Precious Stones, No. 1 Maiden Lane, N. Y.

**Gruet, Jules.**—Importer of all Grades of Real and Imitation Stones. 14 John St., N. Y.

**Hahn & Co.**—Importers of Precious Stones. Cameos, Onyx, Pearls, Intaglios, Amethysts, Garnets, etc. 64 Nassau Street, New York.

**Kahn, L. & M. & Co.**—Importers of precious and imitation stones. 10 Maiden Lane, N. Y.

**Kipling, E. E.**—Importer of Precious and Imitation Stones. Manufacturer of the Patent Foil Solid Metal Back Rhine Stone Brilliant. No. 6 Maiden Lane, N. Y.

**Kipling, R. A.**—Precious and Imitation Stones, No. 24 Maiden Lane, N. Y. Manufacturer Cameos, Agates, Onyx, Etc., Oberstein, Germany. Commission Merchant, 49 Rue De L'Echiquier, Paris.

**Lorsch, Albert**—Importer of Precious Stones, 37 Maiden Lane, N. Y.

**Stirn, Oppenheimer & Co.**—Importers of Black Onyx, Cameos, Turquoise, Sardonyx, Garnets, Rubies and all other Precious and Imitation Stones. German, French and Vienna Novelties. 3 Maiden Lane, N. Y.

#### Safes.

**Butler, W. H.**—Fire and Burglar Proof Safes, 291 Broadway, N. Y.

#### Silverware.

**Gorham Manufacturing Co.**—Union Square.

**Knowles, J. P. & S. M.**—Manufacturers of Sterling Silverware, 20 Maiden Lane, N. Y. Factory, Providence, R. I.

**Shiebler, Geo. W.**—Manufacturer of Sterling Silverware. No. 8 Liberty Place, near Maiden Lane, N. Y.

**Whiting Manufacturing Co.**—Makers of Sterling Silver Ware. Broadway cor. 4th Street, N. Y.

**Wood & Hughes.**—Manufacturers of Fine Silverware. 16 John Street, N. Y.

#### Silver Filigree Jewelry.

**Cuppia, L. A.**—Manufacturer of Solid Silver Novelties, and Importer of Silver Filigree, 19 Union Square.

**Francesconi, Guido**—Importer of Silver Filigree Jewelry, 196 Broadway, New York.

**Hartmann, P.**—Manufacturer of Silver Filigree Jewelry. 36 Maiden Lane, N. Y.

#### Silver Plated Ware.

**Manhattan Silver Plate Co.**—Manufacturers of Silver Plated Ware. Showrooms, 23 John St. Factory, 301 to 305 East 22d St., cor. 2d Ave. Address all communications to Factory.

**Middletown Plate Co.**—Manufacturers of Superior Electro-Plate. Factories, Middletown, Conn., salesroom, 13 John Street.

**Rogers, Smith & Co.**—Manufacturers of Fine Electro Plated Ware. No. 46 E. 14th St., N. Y.

**Rogers & Brother**—Manufacturers of Electro-Plated Flat and Hollow Ware. 690 Broadway, N. Y.

**Schade, Henry.**—Manufacturer of White Metal and Plated Ware. Office, 26 John Street, N. Y. Price list and catalogue furnished on application.

**Simpson, Hall, Miller & Co.**—Manufacturers of fine Silver-Plated Ware. No. 36 E. 14th Street.

**The Derby Silver Co.**—Manufacturers of Finest Quadruple Silver Plated Ware, Birmingham, Conn. New York office, 25 Maiden Lane.

**Webster, E. G. & Bro.**—Manufacturers of Fine Silver-Plated Ware. Office and warehouses, 14 Maiden Lane, N. Y.

#### Show Cases, Etc.

**Smith, B. & W. B.**—Manufacturers of Patent Improved Dust Proof Show Cases, with Perpendicular Sliding Doors, No. 220 W. 29th St., N. Y.

#### Spectacle Case Manufacturers.

**Bertine, P. D.**—Manufacturer of Spectacle and Eye-Glass Cases. 139 William Street, near Fulton St., New York.

**Koenen, A. & Bro.**—Manufacturers of Leather Spectacle and Eye-Glass Cases for the Jobbing Trade only. 81 Nassau St., N. Y.

**Spencer Optical Manufacturing Co.**—Manufacturers of Spectacle and Eye-Glass Cases. 13 Maiden Lane, N. Y.

#### Spectacle and Eye-Class Makers.

**Spencer Optical Manufacturing Co.**—Manufacturers of Spectacles and Eye-Glasses. 13 Maiden Lane, N. Y.

#### Stem Winding Attachments.

**Abbott, Henry** Maker of Stem Winding Attachments, No. 4 Maiden Lane, N. Y.

#### Swivels and Spring Rings.

**Schwartz, V. & Co.**—Manufacturers of Gold Swivel and Chain Trimmings. 33 Barclay Street, New York.

#### Thermometers, Etc.

**Tagliabue, Giuseppe.**—manufacturer of Thermometers, Barometers and Hydrometers. Patentee and sole manufacturer of the U. S. Standard Hydrometer. 302 Pearl Street, near Beekman.

#### Thimble Manufacturers.

**Burbank Manufg Co.**—Manufacturers of Gold and Silver Thimbles, 14 Maiden Lane, N. Y.

**Ketcham & McDougall.**—Improved Gold and Silver Thimbles, Bryant Building, N. Y.

**Simons Bro. & Co.**—Manufacturers of Gold and Silver Thimbles, 611 and 613 Sansom Street, Philadelphia.

**Woglom & Miller.**—Sole Agents for the "Prime" Thimbles in Gold and Silver, manufactured by Ezra C. Prime. 34 John Street, N. Y.

#### Trunks.

**Crouch & Fitzgerald**—Manufacturers of Trunks and Articles for Travelers' use. 1 Cortlandt St., 556 Broadway, and 723 Sixth Ave., N. Y.

#### Watch Companies.

**American Watch Co.**—Robbins & Appleton, No. 5 Bond Street, N. Y.

**Illinois Watch Co.**—Springfield, Illinois. 21 Maiden Lane, N. Y. and 71 Washington Street, Chicago, Ills.

**The E. Howard Watch and Clock Co.**—Cor. Maiden Lane and Nassau Street, N. Y.

**Waterbury Watch Co.**—Manufacturers of the Waterbury Watch. Factory, Waterbury. Office, 52 Maiden Lane, N. Y.

#### Watch and Chronometer Jewelers.

**Queen, James.**—Watch and Chronometer Jeweler and Pallet Maker, 78 Nassau Street, room 8. Pivots inserted in Pinions, Balance, Staffs, etc.

**Robert, Henry L.**—Practical Chronometer and Watch Jeweler and Adjuster. 71 Nassau Street. Pallet and Hole Jewels for Chronometer Watches done in the best manner.

**Wennstrom, John.**—Watch, Chronometer and Clock Jeweling, Jewel Gauges, Ruby and Sapphire Draw Plates; Diamond Charged Polishing Stones for Jewel Settings; Pivots inserted in Pinions. 2 Dutch Street, N. Y.

**Watch Importers, Etc.**

- Abry, Chas. Leo**—Importer and Manufacturer of Swiss Watches of all grades. 63 Nassau Street.
- Aikin, Lambert & Co.**—Importers of Watches, Sole Agents for Paul Breton & Chas. Latour, Geneva. A general line of reliable Swiss Watches, Watch Cases, etc. 23 Maiden Lane, N. Y.
- Bartens & Rice**—20 John Street, Importers of Watches and sole agents in the United States for the celebrated Nicole, Nielsen & Co. Watches.
- Cross & Beguelin.**—Importers of Watches, Watch Tools and Materials, dealers in American Watches, No. 21 Maiden Lane, N. Y.
- Droz, Henry E.**—Importer of Watches, and Watch Case Manufacturer. Agent for the "E. Perregaux" Watch, and jobber in American Watches No. 92 Fulton Street, N. Y.
- Freund Max & Co.**—Importers of Watches, Jewellery and Precious Stones, 8 Maiden Lane, N. Y.
- Gagnebin, Chas.**—Importer of all kinds of Swiss, and Dealer in American Watches. 4 Maiden Lane, N. Y. Agent for Ulysse Breting's Fine Chronometers, Chronographs, Anchors, &c.
- Gallet, Julien.**—Importer of Watches. No. 1 Maiden Lane.
- Ginnel, Henry**—Importer of Watches, Tools and Materials, 31 Maiden Lane, N. Y. P.O. Box 2967
- Hyde's Sons, John E.**—Wholesale Commission Agents, only for Jules Jurgensen, of Copenhagen; Jules Monard, of Geneva; and for other makers of all qualities of Watches, 22 Maiden Lane.
- Keller, L. H. & Co.**—Successors to G. A. Huguenin, Importers of Fine Watch and French Clock Materials, No. 64 Nassau Street, N. Y.
- Mathey Bros. & Mathez.**—Importers of Fine Watches and Sole Agents for the **H. L. Matile's** Watches. No. 16 Maiden Lane.

- Robert, J. Eugene**—No. 30 Maiden Lane, New York. Agent for Louis Audemar's celebrated watches.
- Schumann, Chas. W.**—No. 24 John Street, New York. Importer of Fine Diamonds, Watches, etc. Sole Agent in the U. S. for the celebrated "Lange" Dresden Watch.
- Schwob, Adolphe**—Manufacturer and Importer of Watches, 11 Maiden Lane, N. Y.
- Strasburger, Louis & Co.**—Importers and Makers of Watches of every description, 15 Maiden Lane.

**Watch Cases.**

- Dueber Watch Case Mfg Co.**—Manufacturers of Gold and Silver Watch Cases. Bryant Building, N. Y. Factory, Newport, Ky.
- Fahys, Joseph**—Manufacturer of Watch Cases and Dealer in American Movements, 38 Maiden Lane.
- Glatz, Chas.**—Manufacturer of Silver Watch Cases. Bryant Building, cor. Nassau and Liberty Sts.
- Keller & Untermeyer.**—Manufacturers of Watch Cases with Raised Gold Ornaments. 9 Maiden Lane, N. Y.
- Ladd Watch Case Co.**—Manufacturers of the Ladd Patent Stiffened Gold Watch Cases, etc., 11 Maiden Lane, N. Y. Factory, 58 Eddy Street, Providence, R. I.
- Martins & Tissot.**—Manufacturers of Gold Watch Cases. No. 15 Maiden Lane, N. Y.
- The Brooklyn Watch Case Co.**—Manufacturers of the celebrated Eagle Case. 40 Maiden Lane.
- Willemin Watch Case Co.**—Makers of Gold Watch Cases. Raised Gold Ornamentation and Jurgensen style of Engine Turning. 109 Sands Street, Brooklyn, N. Y. 16 Maiden Lane, N. Y.

**Watch and Chronometer Repairers.**

- Cerf, B.**—Practical Watchmaker and Repairer, No. 10 John Street, N. Y. Repairing and adjusting of Fine Watches done for the trade. All kinds of escape and stem-winding wheels cut to order.
- Goepf, Frederick A.**—Practical Watchmaker. Repairing of every description for the Trade. 25 Maiden Lane, N. Y. In office of H. Garland, Engraver.
- Heinrich, H. H. & Co.**—Sole Manufacturers of H. H. Heinrich's Patent Auxiliary Balance, and Adjusters and Repairers of Fine Watches and Chronometers. 18 John Street, N. Y.
- La Croix, J. H.**—(Late with Benedict's Time,) Watch and Clock Maker, 21 John Street, N. Y. Clocks of every description Repaired for the Trade.
- Lesperance, Theo.**—Watchmaker and Wheel Cutter. No. 1 Maiden Lane, New York. With Julien Gallet.

**Watch Case Repairers.**

- Feinier, Joseph A.**—Watch Case Maker and General Repairer. Specialty in fine Gold and Silver Cases. Jobbing promptly attended to. Nos. 4 and 6 John St., N. Y.
- Tarbox, Hiram**—Watch Case Repairing, Springing, Polishing and Engine Turning. 1874 North Fourth Avenue, bet. 176th and 177th Sts., N. Y. Express Packages should be sent to 92 Fulton Street.

**Watch Glasses, Shades, Etc.**

- Brown, Edwin H.**—No. 85 Nassau Street, Imported and Own Manufacture Watch Glasses, Flat, Flat Concave, Concave, Convex and fine Genevas. Fine fitting solicited.

**Watches, Diamonds and Jewelry.**

- Alford, C. G. & Co.**—Manufacturers. General line fine and Reliable Goods, Specialties in Onyx Goods and Chain. 200 Broadway, New York.
- Cohn, J. J.**—Importer and Manufacturer of Whitby Jet, Rubber and Pearl goods. Gold and Rolled-plate Jewelry, etc. 12 Maiden Lane, New York.
- Durfey & Reynolds**—Successors to Durfey & Shiebler, Watches, Diamonds, Jewelry. No. 9 John Street, (up-stairs) New York.
- Friedman, Saml.**—Wholesale Dealer in Watches and Jewelry, 42 Maiden Lane, N. Y.
- Goddard, John M.**—Manufacturing Jeweler, Seal Rings and Fine Lockets a specialty, No. 3 Maiden Lane, N. Y.
- Greason J. R. & Co.**—Successors to Arthur, Rumrill & Co., 182 Broadway. Manufacturers of Fine Jewelry and Gold Chains, also Diamond Mountings.
- Haskell, H. C.**—Manufacturing Jeweler. Seal Rings a specialty. Special attention to Jobbing of every description. 12 John street.
- Herzog, Louis & Co.**—Importers of Watches, Dealers in Diamonds and Jewelry, 52 Maiden Lane, N. Y.
- Hirsch Bros.**—Dealers in Watches and Diamonds and Manufacturers of Jewelry, No. 23 Maiden Lane, N. Y.

- Jandorf, P. & Bro.**—Importers of Watches and Jewelry, 106 Broadway.
- Kennedy, Frank S.**—Manufacturer and Wholesale Dealer in Jewelry and Gold and Silver Thimbles, No. 13 Maiden Lane, New York.
- Lissauer & Sondheim**—Wholesale Jewelers and Jobbers in American Watches, No. 12 Maiden Lane, N. Y.
- Marx, Kossuth & Co.**—Importers of Watches and Dealers in Jewelry. 39 Maiden Lane, N. Y.
- May, Henry**—Importer and Wholesale Dealer in Watches and Diamonds, and Manufacturing Jeweler. 19 John St., N. Y.
- Mayer, B.**—Manufacturer of Fine Jewelry, and Dealer in Watches, 71 Nassau street, cor. John street, New York.
- Myers, S. F. & Co.**—Manufacturing and Wholesale Jewelers—all grades. Importers of Watches. Illustrated Catalogue to the trade. 179 Broadway, N. Y.

- Oppenheimer Bros. & Veith.**—Dealers in Watches and Diamonds, and Manufacturing Jewelers, No. 35 Maiden Lane.
- Scott, J. T. & Co.**—Importers of Watches, and Manufacturers of Jewelry, and Jobbers of all Grades of American Watches, 4 Maiden Lane.
- Smith & Knapp**—Wholesale Dealers in American and Swiss Watches, Diamonds, Gold and Plated Jewelry and Gold Chain. 182 Broadway, N. Y.
- Steele, J. W.**—Successor to Brainerd, Steele & Co., Manufacturer of Fine Jewelry and Brainerd's Patent Lockets. No. 9 Maiden Lane, N. Y.
- Stern Brothers & Co.**—Importers of Swiss Watches and wholesale dealers in American Watches, &c., 39 Maiden Lane.
- Stern & Stern**—Dealers in Watches, Jewelry and Diamonds. No. 6 Maiden Lane, N. Y.
- Stites, D. H. & Son**—Manufacturers of Fine Jewelry, Rolled Plated Goods and Chains, Parisian Diamond Rings, Studs and Earrings a specialty. 41 Maiden Lane, N. Y.
- Strauss, Jacob.**—Full Line of Gold and Plated Jewelry, and Importer of Watches. 18 John Street, New York.
- Thrall, E. A.**—Wholesale Dealer in Watches and Jewelry. No. 1 Maiden Lane, N. Y.

**Trier Bros.**—Importers of Garnet, Whitby Jet and Amber Jewelry, Silk Guards, Opera, Field and Marine Glasses, Pearl Card Cases. Also a full line of Gold and Plated Jewelry. 15 Maiden Lane, N. Y.

**Wheeler, Parsons & Hays.**—Manufacturers of Fine Jewelry, Watch Cases, Gold Chains, &c. and Dealer in American and Swiss Watches, No. 2 Maiden Lane, N. Y.

**White, N. H.**—Jobber in American-Waltham Watches and Chronographs. Waltham make of 10-k., 14-k. and 18-k. Gold and Sterling Silver Cases; Filled Gold Cases. 11 Maiden Lane.

**Watch Tools, etc.**

- Keller, L. H. & Co.**—Importers of Watchmakers' and Jewelers' Tools, Materials, etc. 64 Nassau Street, N. Y.
- Zimmern, Henry**—Importer of Watch Materials, Tools, and Optical Goods, No. 8 Maiden Lane, (first floor.) Sole Agent for A. Hugenin & Gravier. Mainsprings, New York.

**PHILADELPHIA**

- Bennett, Jacob & Son.**—Diamond Setters and Manufacturing Jewelers, 925 Chestnut St.
- Bernard & Co.**—Manufacturers of Fine Roman and Etruscan Jewelry. Designs of every description made to order, 123 & 125 South Eleventh Street, Philadelphia.
- Booz & Co.**—Makers of Fine Gold Watch Cases and Plain Gold Rings, also Dealers in all American Movements, Diamonds, Jewelry, etc. 108 South 8th Street, Philadelphia.
- Conover David F. & Co.**—American Watches, Wholesale Salesroom, Southeast corner 7th and Chestnut Streets, Philadelphia.
- Herold, Chas P.**—Successor to Hildebrandt, Herold & Co., Manufacturing Jeweler and Diamond Setter. Diamonds. 916 Chestnut Street.
- Krieder, Peter L.**—Manufacturer of Sterling Silver Ware. 618 Chestnut Street, Philadelphia.
- McCall & Newman**—Manufacturing Jewelers. Makers of the Original Gold Crown Filled Rings. No. 625 Arch St., Philadelphia.
- Morgan & Headly.**—Manufacturing Jewelers. Cameo Sets, Gold Sets, Roman Lockets, Rings, Coral Sets and a general line of rich goods. Corner 10th and Chestnut Streets, Philadelphia.
- Muhr's, H. S. Sons.**—Manufacturing Jewelers. Solid Gold and Filled Rings a specialty. 633 and 635 Chestnut Street, Philadelphia. 1½ Maiden Lane, New York.
- Peters, Reese S.**—Manufacturer of Patent Rolled Plate or Filled Watch Cases, Dealer in American Movements, 308 Chestnut Street, Philadelphia.
- Rosenthal, G. F. C.**—Manufacturing Jeweler and Diamond Setter. Engraving and Designing of Monograms a specialty. No. 917 Sansom Street.
- Scherr, L. A. & Co.**—Wholesale Dealers in Watches Silver-Plated Ware, Spectacles, Fancy Goods, Watch Materials, etc. 726 Chestnut Street.
- Sheafer, W. H. & Co.**—Manufacturing Jewelers. Specialty: Band Bracelets. Factory, 612 and 614 Chestnut street, Philadelphia. Office, 15 John street, New York.
- Simons, Brother & Co.**—Manufacturers of Fine Jewelry, Canes, Thimbles, Chains. 611 and 613 Sansom Street.

**CHICAGO.**

- American Watch Company.**—of Waltham, Mass. No. 102 State Street, Chicago.
- Clapp & Davies.**—Wholesale Jewelers, 63 and 65 Washington Street. Catalogue and price list issued to watchmakers and jewelers.
- Dennison Manufacturing Co.**—Manufacturers of Jewelers' Paper Boxes, Morocco Cases, Tags, Cards, Pink and White Cotton, Tissue Papers, Sealing Wax, &c., &c., 102 Madison St., Chicago. Boston, New York, St. Louis, and Philadelphia.
- Gilbert, Wm. L., Clock Co.**—Manufacturers of Clocks, Regulators, and Time Pieces, and Clock Material of every description, 54 and 56 Madison Street, Chicago.
- Giles, Bro. & Co.**—Manufacturers and Jobbers in Watches, all classes of Jewelry, Materials, Clocks, Silver Ware, &c. Illustrated catalogues furnished to dealers on application. 101 & 103 State St.

**NEWARK.**

**Baker & Co.**—Gold, Silver and Platinum Refiners Assayers and Sweep Smelters. 408 New Jersey Railroad Avenue, cor. Murray St., Newark, N. J.

**Diefenthaler Bros. & O'Donnell**—Manufacturers of Fine Jewelry, Lace Pins, Ear Rings and Patent Spring Bangles a Specialty. 36 Crawford Street, Newark, N. J.

**Enlish & Miller**—Manufacturers of Gold Jewelry, Diamond and Fancy Stone Rings, Roman Lockets, Bangle and Flexible Bracelets, Knife Edge Lace Pins and Sets, Scarf Pins and Link Buttons. 61 and 63 Hamilton St., Newark.

**Felger, F. & F.**—Manufacturing Jewelers. Specialties:—Roman Band Bracelets, Lace Pins, Scarf Pins, Ball and Fancy Ear Rings. No. 477 Washington Street, Newark, N. J.

**Fiedler, Herrman**—Successor to Kunze & Fiedler, Engraver, Die Sinker and Press Tool Maker, 363 Market Street, Opposite Pennsylvania R. R. Depot, Newark, N. J.

**Glorieux, W. L.**—Assayer, Refiner and Sweep Smelter. 13 and 15 Franklin Street, Newark, N. J.

**Hopper & Wilson**—Manufacturers of Fine Jewelry, No. 8 Maple Place, Rear 44 Green St., Newark, N. J.

**Huger & Heitlinger**—Manufacturers to the Jobbing Trade only. Makers of Roman, Stone, Engraved and Enameled Lockets a specialty. Also Sleeve Buttons, Collar Buttons and Studs. 477 Washington Street, Newark, N. J.

**Krippendorf, C. & Schuller, F.**—Machinists and Jewelers' Tool Makers. 19 Greene Street, Newark, N. J. Rolls, Dies, Cutters, and Draw-plates of every Description made and repaired.

**Lelong, L. & Bro.**—Gold and Silver Refiners. Assayers and Sweep Smelters, Southwest corner of Halsey and Marshall Streets, Newark, N. J.

**Milne, Alex.**—Manufacturer of Stem-winding Watch Crowns. 19 Ward Street.

**Nesler & Co.**—Manufacturers of 18 Kt. Gold Filled Hoop Ear Rings, Plain, Facet and Engraved, all sizes. 36 Crawford St., Newark, N. J.

**Regad, E. D.**—Lapidary. Specialty—Sardonyx, Black Onyx and Agates. 14 Oliver St., Newark.

**PROVIDENCE**

**Arnold & Webster**—Manufacturers of Solid Gold Engraved Band Rings for the Jobbing Trade. 29 Point Street, Providence, R. I.

**Butts, Geo. F.**—Manufacturing Jeweler. Ladies' and Misses' Solid Gold Drops and Studs a Specialty. 119 Orange Street, Providence, R. I.

**Bradley, R. & Son**—Manufacturers of Solid Gold and Rolled Plate Jewelry. White Stone Goods a Specialty. 227 Eddy Street, Providence, R. I.

**Capron & Co.**—Manufacturers of Jewelry. Engraved Box Bracelets, Bangle Wire Bracelets, Original Lever Collar and Cuff Button. No. 407 Pine Street, Providence, R. I.

**Elmwood Paper Box Co.**—Makers of Jewelers' Cases, Trays, etc. Factory, 54 Greenwich St., Providence, R. I.

**Hamilton, William & Co.**—Manufacturers of Fine Rolled Plated Chains and Patent Band Bracelets. 116 Pine St., Providence, R. I.

**Harrington, J. C.**—Maker of Fine Gold Plated Jewelry. Specialties:—Oval Wire Bangles, Band Bracelets and the Victor Swivel. 129 Eddy St., Providence, R. I.

**Hough, W. S., Jr., & Co.**—Manufacturers of the Hough, Jr., Rolled Plate Lockets, Charms and Pendants. For sale by all first-class Jobbers or Wholesale Jewelers in the United States and Canadas.

**Hutchison & Huestis**—Makers of Solid Gold Rings. Quality guaranteed. For the Jobbing Trade only. 185 Eddy Street, Providence, R. I.

**Irons, Chas. F.**—Manufacturer of Solid Gold Jewelry. Specialty, Emblems, Pins and Charms, Masonic, Odd Fellows, etc. 102 Friendship St.

**Pitts & Hicks**—Manufacturers of the Excelsior Button and Eclipse Lever Button, also a line of White Stone Gold Goods and a fine line of Lace Pins and Drops in Rolled Plate Goods. 120 Dorrance Street, Providence, R. I.

**Taylor, Geo. H. & Co.**—Watchmakers and Wholesale Dealers in Watches, Clocks, Watch and Clock Material, Tools, Spectacles, Eye Glasses, &c. Particular attention given to trade work. 136 Westminster Street (Room 1), Providence, R. I.

**PAWTUCKET.**

**Fuller, Geo. H. & Son**—Jewelers' Findings, Gold, Silver, Gold Plated and Fire Gilt. Pin Stems, Joints, Catches, Split Rings, Chain Hooks and Swivels, Ear Wires, Chain Bars, etc. 99 Exchange Street, Pawtucket, R. I.

**CINCINNATI.**

**Holland, John**—Manufacturer of Gold Pens, Pencils and Pencil Cases, Gold Toothpicks, etc. Nos. 19 and 21 W. 4th St., Cincinnati, Ohio.

**Lodwick & Nolting**—Wholesale Jewelers (exclusively), S. W. cor. Fourth and Walnut Streets, Cincinnati, Ohio.

**BOSTON.**

**Boston Watch Case Co.**, makers of Watch Cases. Especial attention given to Repairing. 1, 3 & 5 Province Court, Boston, Mass.

**Boyce, E. J.**—Manufacturer of Solid Gold Jewelry. Rings a Specialty. 383 Washington St., Boston, Mass.

**Weber, H. & Co.**—Wholesale Jewelers, Importers and Jobbers of Fine Watch Materials, Jewelers' Findings, Tools, etc., Optical Goods and Silk Guards. Agents for Whitcomb, Standard and Stark's Lathes. 424 Washington St., Boston, Mass.

**BUFFALO.**

**Klein, E. F. O.**—Jobber in Watch Materials. Watches and Chronometers repaired and adjusted for the trade; also Gold and Silver Plating. Sample Bottle of "Magic Solution," for cleaning Watches, including receipt, to any address, on receipt of \$1.50. This is a great time-saver and does the finest work. No one will do without it if used once. 346 Broadway, Buffalo, N. Y.

**Oliver, W. W.**—Manufacturer of Hand and Power Rolling Mills for Jewelers and Silversmiths, 39 Clinton Street, Buffalo, N. Y.

**CLEVELAND.**

**Chandler, J. M. & Co.**—Manufacturers of the Patent Embossed Bracelet and Jobbers in all kinds of Clocks, Watches, Jewelry, Tools, Materials, etc. 185 Superior St., Cleveland, O.

**LANCASTER.**

**Powman & Musser**—Jobbers in Watches, Clocks, Chains, Fine Tools and Materials. 20 East Chestnut Street, Lancaster, Pa.

**PITTSBURGH.**

**Barrett, G. B., & Co.**—Wholesale Jewelers and Diamond Importers. We carry a line of everything required by the trade. Lowest prices guaranteed. 101 Fifth Avenue, Pittsburgh, Pa.

**Goddard, Hill & Co.**—Wholesale Dealers in American Watches, Jewelry, Silverware, Clocks, Materials, &c., 43 Fifth Avenue, Pittsburgh, Pa.

**Hodge, Slemmons & Co.**—Wholesale Dealers in American and Swiss Watches, Diamonds, Gold and Plated Jewelry, Clock Material, etc. No. 77 Fifth Ave., Pittsburg.

**NEW BEDFORD.**

**Nye, W. F.**—Manufacturer of Watch, Clock and Chronometer Oils, New Bedford, Mass.

**Wheeler, G. B.**—Manufacturer of Watch and Chronometer Oils, New Bedford, Mass.

**WORCESTER.**

**Washburn & Moen Manufacturing Co.**—Makers of Fine Watch Mainsprings, Worcester, Mass. 16 Cliff Street, New York. 107 to 109 Lake Street, Chicago, Ill.

**WINCHESTER.**

**Goodell & Winn**—Manufacturers of American Watch Hands, Winchester, Mass.

**ALBANY.**

**Reiss, Chas.**—31 and 33 So. Pearl Street, Albany, N. Y. Importer of Watch Tools and Material; General Supply; Low Prices. Repairing for the Trade.

**KEOKUK, IOWA.**

**Ayres, T. R. J., & Sons**—Wholesale Jewelers. Watches, Jewelry, Diamonds, Silverware, Clocks, Optical Goods, Tools, Material, &c, at lowest eastern prices. Correspondence solicited.

**CANADA.**

**Ellis, P. W. & Co.**, No. 31 King street, East Toronto, Ontario, Manufacturing Jewelers, Watchmakers, importers and Jobbers of Watchmakers, and Jewelers' Tools, Materials, General Supplies and American Jewelry. Correspondence solicited with manufacturers of Novelties or specialties in American Tools and Jewelry.

GEO. W. DUBOIS.

F. N. NAUMAN.

**GEO. W. DUBOIS & CO.,**

IMPORTERS OF

**Watches & Optical Goods.**

ALL STYLES AND QUALITIES OF

**SPECTACLES AND EYE-GLASSES.****Longines' Watches and Movements,**

The Watches in Gold, Silver and Nickel Cases of New and Handsome Patterns. The Movements fit 18 size Waltham Stem Winding Hunting Cases.

**36 Maiden Lane, New York.**

ORDERS BY MAIL RECEIVE PROMPT ATTENTION.

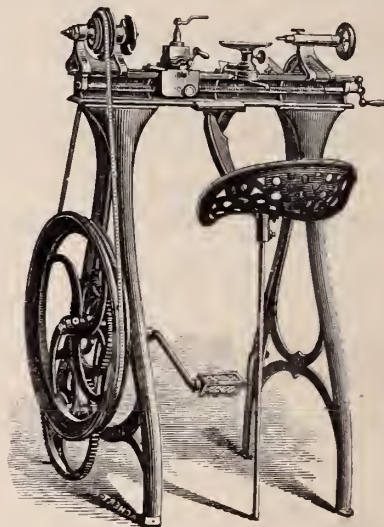
**BARNES' No. 4 LATHE,**  
For the Heavier Work of Jewelers.

Barnes' Patent Foot and Steam Power Machinery. Complete outfits for Actual Workshop Business. Lathes for wood or metal. Circular Saws, Scroll Saws, Formers, Mortisers, Tenoners, etc., etc. Machines on trial if desired. Descriptive Catalogue and Price List Free.

**W. F. & JOHN BARNES,**  
2088 Main Street, ROCKFORD, ILL.

**American Lens Mfg. Co.,**

MANUFACTURERS OF

**Optical and Object Lenses**

OF ALL KINDS.

**KATONAH, N. Y.**

Spectacle Lenses a Specialty.



**E. J. BOYCE,**

(Formerly Boyce & Wainwright,)

→ **MANUFACTURING & JEWELER** ←

*SOLID GOLD RINGS A SPECIALTY.*

My **BAND RING** Specialties, for **PRICE, QUALITY** and **FINISH**, are not equaled by any in the Trade,

**383 WASHINGTON ST.,**  
BOSTON, MASS.

**S. DAVIDSON,**

IMPORTER OF

**DIAMONDS & WATCHES,**

MANUFACTURER OF

*DIAMOND JEWELRY,*

**No. 9 JOHN STREET,**  
NEW YORK.

Goods sent on selection to any part of the United States upon satisfactory reference.

Solid Gold Rings a Specialty.

**WM. H. ELY,**

**SOLID GOLD RINGS,**  
MANUFACTURER.

Viz., Plain, Chased, Engraved, Enameled, Engine Turned, Shield and Scale. All qualities guaranteed. Orders Promptly Executed.

58 Nassau Street, New York.

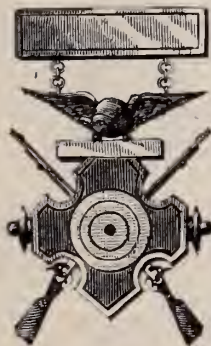

**C. B. WILKINSON,**

Manufacturing & Jeweler,

8 JOHN ST., N. Y.

Medals, Badges and Masonic Jewelry

**A SPECIALTY.**

Designs furnished free upon application.

**H. WUNDOEHL,**

**GOLD & SILVER REFINER,**

Assayer and Sweep Smelter,

**21 JOHN ST.,**

Bet. Broadway & Nassau St., **NEW YORK.**

The highest price paid for Gold, Silver and Platinum. *Fine Gold, Silver and Copper always on hand.*

**Washburn & Moen M'fg. Co.,**

**WORCESTER, MASS.**

Manufacturers of Fine Watch Mainsprings for American, Swiss and English Watches, which, for Toughness, Elasticity and Finish, are Unequaled.

N. Y. Warehouse: **16 Cliff Street.** Chicago Warehouse: **107 to 109 Lake St.**



**ELK SKIN BUFFS,**

The Very Best Polishing Material Known.

MANUFACTURED BY

**CHAS. A. WINSHIP,**

**200 Kinzie St., Chicago, Ills.**

Inside Buffs for Lathes.....20c. Each.  
Outside " " " .....25 to 35c. "  
Buff Sticks.....20c. "  
Ring Buffs.....25c. "

Samples sent Postpaid on receipt of price in Stamps, Postal Note or Money Order.

**BUERK'S WATCHMAN'S TIME DETECTOR.**



Safety Lock Attachment Patented April 25, '82.

Used by all large manufacturing establishments, public buildings, warehouses, etc., to control watchmen. The simplest, strongest, cheapest and most complete of its kind made.

Price, with pouch, 400 paper dials, record book, and 12 different keys with chains for 12 different stations,

**COMPLETE, \$50.00.**

**O. E. HAUSBURG,**

**71 NASSAU ST., Room 3,**

P. O. Box 1239, **NEW YORK.**

**H. WASELL,**

**RUBBER STAMPS,**

**BRASS STAMPS,**

Brushes, Inks, &c.

Stencil Plates,

Burning Brands,

**SEALS & PRESSES,**

**No. 7 North William St.**

First house South of East River Bridge, N. Y.

**FINE STEEL STAMPS A SPECIALTY.**

**J. WIENHOLD,**

Manufacturer of Fine Jewelry.

**DIAMOND MOUNTINGS**

**A SPECIALTY.**

24 JOHN ST., N. Y. CITY.

**HIBBARD G. GILL,**

**GOLD AND SILVER**

**Watch Case Manufacturer,**

Dealer in Watches,

American Watch Movements Always on Hand.

**618 Chestnut Street,**

Fifth Floor.

PHILADELPHIA.

**HENRY TROEMNER,**

**710 Market Street,**

PHILADELPHIA.

Manufacturer of Fine Gold Scales,

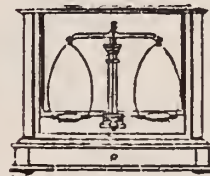

**DIAMOND SCALES,**

Bullion Balances and Weights, in use at all the U. S. Mints and Assay Offices.

PRICED CATALOGUE ON APPLICATION.

**JNO. F. LUTHER,**

MANUFACTURER OF

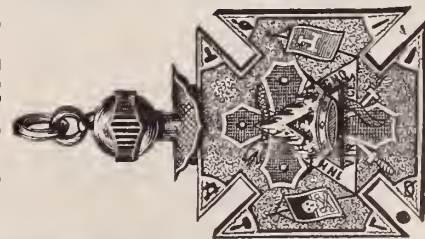

Masonic Jewelry.

**79 Nassau Street, N. Y.**

Illustrated Catalogue sent on application

ADOPTED AND IN USE BY  
**RANDEL, BAREMORE & BILLINGS,**  
58 Nassau Street, N. Y.

THE TRADE SUPPLIED.  
Descriptive Circulars Furnished  
on Application to  
**George W. Washburn, Patentee,**  
58 Nassau St.,  
NEW YORK.

**SAFETY**  
**EAR FASTENING,**   
*Pat. May 10, '81—Oct. 11, '81.*

**Jointed**  
**EAR WIRE**  
AND  
**BAR BETWEEN CRAMPS**  
**OF SETTINGS.**   
*Patented March 1, 1881.*

**TELESCOPIC**  
**SAFETY PIN CATCH,**   
*Pat. Sep. 20, '81—Jan. 10, '82.*

New \* York \* Morocco \* Case \* Co.

**CASES FOR**  
Jewelry, Silverware & Watches  
OF EVERY DESCRIPTION.  
Boxes and Trays for Jewelry Travelers,  
TRUNKS FITTED UP WITH TRAYS.  
Show Cases and Window Fittings  
a Specialty.  
No. 69 NASSAU STREET, NEW YORK.

**C. KNAPP,**  
Manufacturer of  
**Superior Band**  
and Children's  
**Stone & Fancy**  
**RINGS**  
And Enameled Goods,  
41 Maiden Lane,  
NEW YORK.



**ROBERT H. RAMSGATE,**  
16 MAIDEN LANE, N. Y.  
*Formerly 4 Liberty Place.*  
**DIAMOND CUTTER AND POLISHER.**  
Cutting from the Rough, Re-Cutting, Re-  
pairing and Matching.  
**Diamond Powder and Bortz always**  
**on hand.**  
Dealers will do well to get Estimates before going  
elsewhere.

ESTABLISHED 1873

**CHAS. P. HEROLD**  
MANUFACTURER JEWELER  
**DIAMONDS**  
916 CHESTNUT STREET, UP STAIRS  
PHILADELPHIA



**WATCHMAN'S IMPROVED**  
**TIME DETECTOR,**  
WITH SAFETY LOCK ATTACHMENT.

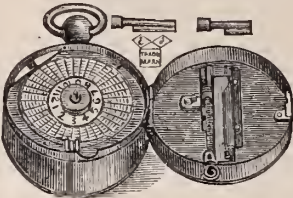

Patented 1875, 1876,  
1877, 1880, 1881, 1882.  
This instrument is  
supplied with 12 keys.  
Invaluable for all con-  
cerns employing  
watchmen. It contains  
all modern improve-  
ments, and is far supe-  
rior to the old style.  
1883—At the National  
Exposition for Rail-  
way Appliances at Chicago. The only Medal for the most  
complete and Perfect Instrument. P. O. Box 2875.  
Send for Circulars to

**E. IMHAUSER, 212 Broadway, New York.**

**SAMUEL EAKINS, Jr.,**  
PRACTICAL  
**Electro Gold and Silver Plater,**  
**618 CHESTNUT ST.,**  
3d Floor, Rooms 11 & 12. PHILADELPHIA.

**Repairing, Re-Plating and Gilding in the**  
**best manner.**  
Oxidizing, Platinizing and Coloring of Jewelry  
a Specialty

**EXCELSIOR'S**  
Practical Treatise  
ON THE  
**BALANCE SPRING**  
Including Making and Fitting Hair Springs,  
Regulating, etc.  
Also containing the Adjustment of Watches  
and Chronometers for Isochronism, Posi-  
tions, Heat and Cold and Rate.  
**PRICE, \$3.50.**

**D. H. HOPKINSON,**  
42 Nassau Street, New York.



ESTABLISHED 1869.

**The**  
**Jewelers'**  
**Circular**  
AND  
**Horological Review.**

THE RECOGNIZED ORGAN  
OF THE TRADE.

Subscription \$2.00 per Annum.

D. H. HOPKINSON,  
*Editor and Proprietor,*

42 NASSAU STREET,  
New York.



**WALKER & COMPANY**

**IMPORTERS OF DIAMONDS**

**AND MANUFACTURERS OF FINE JEWELRY.**

We have this season the Largest Assortment of

→ Diamonds, Diamond Mountings, and Initial and other Seal Rings →  
of every description ever introduced. Goods sent upon application to responsible dealers.  
Special Designs furnished at any time upon application, and Estimates given on the same.

**MALDEN MASS. N. Y.**



# Spencer Optical Manuf'g Co.

ARE MAKING MANY  
NEW AND DESIRABLE STYLES  
FOR THE  
EARLY FALL TRADE.  
BETTER FINISH.  
PRICES THE LOWEST.

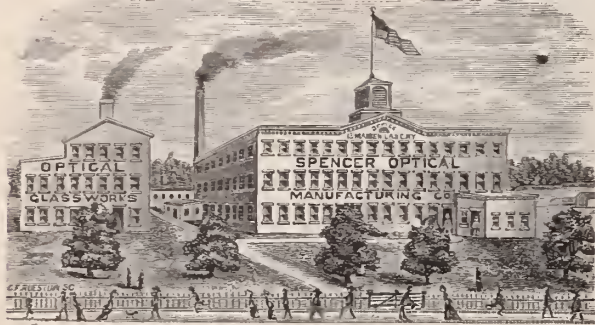

## Great Reductions in Rubber Eye-Glasses. GREAT REDUCTIONS ON PEBBLES.

The Most Perfect Pebble Tester ever made. Works Instantaneous.  
No directions required. Price, \$1.50- half the price of  
Common Imported Testers.

Our GOLD GOODS are Unsurpassed for  
**Beauty, Durability and Finish.**  
QUALITY GUARANTEED.

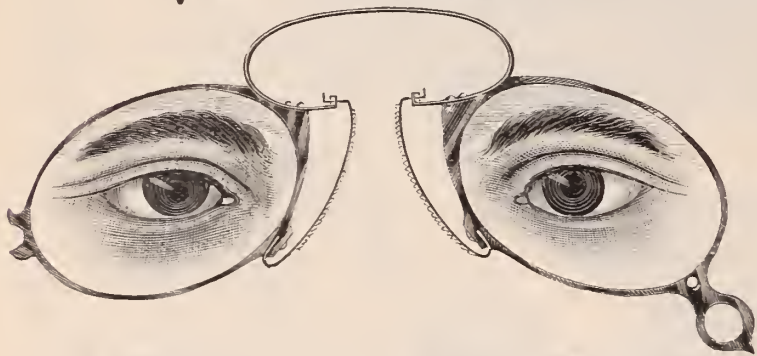

### CELLULOID SPECTACLES AND CELLULOID EYE-GLASSES

have made their own reputation and are universally popular wherever introduced.

**BEWARE OF IMITATIONS.**

If you wish a Specialty, call on us.

We make a SPECIALTY in SPECIAL GOODS for the FINE RETAIL TRADE, which gives customers handling our goods IMMENSE ADVANTAGE over all others, each dealer having a Specialty of his own, thereby destroying the ruinous competition which exists in many cities at the present day.

**QUALITY OF GOLD GUARANTEED.**

We are importing large Invoices of Opera, Field and Marine Glasses in Staple and Novel Designs.

Catalogue sent on receipt of Business Card.

**Spencer Optical Manufacturing Co.,**  
13 MAIDEN LANE, NEW YORK.

Established 1853.

# L. H. KELLER & CO.

Successors to G. A. HUGUENIN,

IMPORTERS OF

WATCHMAKERS' and JEWELERS'  
**TOOLS AND MATERIALS.**

GENERAL AGENTS FOR

The Philadelphia Watch Company,

— AND —

American Watch Tool Co.,

MANUFACTURERS OF

**THE WHITCOMB LATHE.**

SOLE AGENTS IN THE UNITED STATES FOR THE SALE OF

**LUTZ'S**  
**CELEBRATED ROLL HARDENED HAIR SPRINGS,**  
**MOEBIUS OIL**

For Chronometers, Watches, Clocks, Telegraph Instruments and all other delicate machinery. Made from Pure Refined Neatsfoot Oil, and Warranted to Excel anything in the market as a Lubricator. SAMPLES GRATIS.

**OUR OWN GRADUATED**  
AND JURGENSEN RECOILING MAINSPRINGS, pronounced by all experts Superior to all. Sold in Separate Strengths or Force.

Extra Fine Pinions cut from Solid Steel Wire. Gauged Hole Jewels of First-class Workmanship. A Full Line of Materials, for the PATEK, PHILIPPE & CO. GENEVA WATCHES, and all other Celebrated Makers.

### THE BOLEY LATHES AND TOOLS,

Celebrated for their Practical, Substantial and Workmanlike Construction, Superior Design and Finish.

*Our aim is to furnish nothing but First-class Serviceable Goods, especially manufactured for the Consumer, and not solely for the Market, like the cheap trash advertised in highly illustrated catalogues with which the country is flooded.*

**TREATISE ON MODERN HOROLOGY IN THEORY AND PRACTICE.** By M. CLAUDIUS SAUNIER, Ex-Director of the School of Horology at Macon, France; Knight of the Legion of Honor, etc.; Hon. Sec. to the Paris Society of Horologists. Translated from the French by JULIEN TRIPPLIN, Besançon Watch Manufacturer, and EDWARD RIGG, M. A., Assayer in the Royal Mint, London.

This Work comprises 832 large octavo pages, with 78 wood cuts and 21 colored double-page copper-plate engravings. Bound in half calf, with an appropriate and handsome ornament in gold on front cover.

**Price, \$15.00.**

**THE WATCHMAKER'S HAND BOOK.** By the same author and translators. Intended as a companion to the Treatise. Bound in cloth.

**PRICE, \$4.00.**

**64 Nassau Street,**

NEAR MAIDEN LANE,

**NEW YORK.**

L. H. KELLER,  
EDWARD HUNZIKER,  
F. J. BOESSE.

We do not publish Price Lists.

**SPECIAL NOTICES.****Notices under this heading, not to exceed Six Lines, \$1.00 each insertion.**

Advertisers having letters addressed in care of this office, must inclose postage for answers forwarded.

**WANTED**—A first-class jeweler and engraver. To a good man a permanent situation and good wages. Address Williams & Stevens, Macon, Ga.

**WANTED**—A first-class letter and monogram engraver immediately. Address, giving references, Merrick, Walsh & Phelps, Jewelers, St. Louis, Mo.

**WANTED**—Situation by a good watch repairer. Best of reference and tools. First-class American lathe. Address A., care John Carver, Chardon, O.

**A PRACTICAL WATCHMAKER**, with moderate means and fifteen years' business experience, would like to hear of a first-class business opportunity. Address Charles E. Lewis, Suspension Bridge, N. Y.

**WANTED**—A watchmaker, must give good references as to honesty, etc. State experience, age and salary wanted. A permanent situation to the right party. Address G. W. Pratt & Co., 14 John St., N. Y.

**WANTED**—A first-class watchmaker and engraver with the very best of references, to go to Jacksonville, Fla. A young or middle aged man preferred. Address H. B. Smith, P. O. Box 383, Jacksonville, Fla.

**WANTED**—The addresses of all traveling dealers in watch materials, etc., to introduce an easily selling and well paying novelty. Communications will oblige H. B., care Editor Jewelers' Circular, 42 Nassau St., N. Y.

**MOSELEY & CO.**, Elgin, Ill., manufacturers of the "Moseley" Lathe, with full line of fixtures and attachments. Designed especially for the watchmaker and repairer. Combining accuracy, durability, convenience and style.

**FOR SALE**—First-class watch repairing and jewelry business; 3 journeymen watchmakers constantly kept. First-class opening. For particulars apply with stamp to J. Anderson, 294 Queen St., West Toronto, Ontario, Canada.

**SITUATION WANTED**—As traveling salesman by a young man of some years' experience on the road. Smart and enterprising. Still with old house but desirous of making a change. Excellent references. M. L. S., Circular Office.

**WANTED**—SPENCER'S OPTHALMOSCOPE.  
FOR SALE—ENGRAVING MACHINE.  
**JOHN BLISS TRANSIT**, No. 8,  
Staking tool, 30 inch watch sign, wheel stretcher. Box 94, Nashville, Tenn.

**JEWELRY STORE FOR SALE**—Rare chance for either watchmaker or jeweler; business established nine years in one of the best locations in Brooklyn. Good reason for selling. Capital required, \$2,000. Address H, care Jewelers' Circular.

**EVERY WATCHMAKER** in the United States should know my valuable discovery. Over two thousand (2,000) sold during the past month. Send your address for particulars. J. B. Dale, Jeweler, P. O. Box 686, Edwardsville, Madison Co., Ill.

**TRAVELING SALESMAN** will be open for an engagement with a jewelry house or manufacturer after Oct 10th. Will travel on commission or salary until Jan. 1st, then if satisfactory will make engagement for the following year. O. E. A., care Jewelers' Circular.

**FOR RENT**—Desk and vault room in the Jewelers' Exchange Building, corner State and Washington streets, Chicago. Fire-proof building. Fire and burglar-proof vault. Suitable for manufacturing jewelers or importers office. Logue & Baro, 104 State St., Chicago.

**WANTED**—Situation as watchmaker by a sober young man with four and a half years' experience at the bench in a large establishment with a first-class workman. Can furnish best of references. Address stating particulars, Temperance, care Jewelers' Circular

**GEORGE E. WILKINS**, manufacturer and importer of cutters for watchmakers' use, stem-winding cutters of all the different forms, rounding up cutters of the finest quality, also ratchet cutters. A large stock of second hand and new marine chronometers. No. 21 South Salina street, Syracuse, N. Y.

**WANTED**—A partner who is a practical watchmaker and jeweler, and can furnish from 3 to \$4,000 to buy half interest in an old established jewelry business of 40 years, in a live southern town of 10,000 inhabitants. A rare chance for an energetic young man. Address Partner, care Jewelers' Circular.

**ELECTRO GILDER**, plater, nickeler, etc., thoroughly competent; managed department largest works in Europe. Expert in gilding every description. Undeniable character; 3 years with one firm in Canada. Will be open to re-engagement shortly. Address Electro, 46 Dover Court Road, Toronto, Ont., Canada.

**WANTED**—Situation by young man, Penna., who has had 10 years' experience in retail jewelry business, to take the road in the spring for some good house where good habits and strict attention to business will be appreciated. Reference or security to any amount furnished. Address Energy, care Circular.

**FOR SALE**—First-class jewelry store in town of 8,000 population and thickly settled country around. Leading store of the place in stock and trade. Will invoice stock and fixtures about \$5,000. Reasons for selling are not a practical jeweler and want to move west. Address C. C., care Jewelers' Circular.

**FOR SALE**—A good jewelry business in southern California, near Los Angeles, a town of 3,500 inhabitants, in a rich, growing section. Stock \$4,000, but could be reduced if necessary. Good run of bench work and sales good. For further particulars address Giles, Bro. & Co., Chicago, or H. T. Hollingsworth, Los Angeles, Cal.

**WANTED**—Every reader of this book to send for a sample package of my printed stationery, consisting of 100 envelopes, 100 note heads and 25 fine cards, all nicely printed, and sent post paid to any address for one dollar. Good stock and good work. Sure to suit. Send full address as follows: Ernest F. Robbins, Lock Box 24, Norwood, Mass.

**WANTED**—Two first-class watchmakers who have American lathe and tools of their own. We want men who have learned the trade and can do first-class work. Must thoroughly understand escapements and do staff and pivot work. We will give good wages and permanent situation to steady men who are skilled. Address at once, J. P. Stevens & Co., Atlanta, Ga.

**TUBING** of every description drawn to order at short notice. Gold pen, pen and pencil cases, novelties, tooth picks, at lower prices than can be purchased elsewhere. Sample line sent on approval to approved parties. Gold pens re-pointed, repaired, exchanged. Ray Manufacturing Company, salesroom and factories, 94 & 96 Nassau St. and 129, 131 and 133 Fulton St., New York.

**TIME IS MONEY**—An accurate, hard and highly finished balance staff made in one-half the average time; no dirt, no acid, grease, charcoal or extra tools used. My process is simple, clean and quick, and my own invention. Every watchmaker will see its merits at a glance and profit by its use. Send for receipt and testimonials. Price, \$1.00. F. C. Rice, 103 Second street, Macon, Ga.

**TO THE TRADE**.—I make a specialty of supplying the Trade with stones for jobbing purposes. Parties having jewelry out of which the stones have been lost, sending their orders by mail or express, will have them promptly attended to. A large stock of cameos, pearls, turquoise, garnets, amethysts, doublets, foil backs, white and colored imitation stones on hand. All kinds of setting done for the Trade. W. Archibald, 73 Nassau street, New York.

**FOR SALE**—My retail jewelry and music business, established in 1854. A splendid record; thirty years' successful business; 12 to \$15,000 stock, including fixtures, etc. Reason for selling, moving to Des Moines, where I can pay exclusive attention to my wholesale department. Also my residence and store-room for sale. A rare chance for a live party or parties. No charge for good-will. Possession given immediately. G. W. Marquardt, Iowa City.

**FOR SALE**—A good paying jewelry business in a good live city in middle Nebraska. 3,500 inhabitants, 4 good railroads, county seat, and surrounded by a good farming country. Present stock about \$10,000, can be reduced to suit purchaser. A good run of work, enough for 2 men; good prices for everything, competition light, rent low, and the best location in the city; good, nice and clean stock, all staple. There was never a chance better than this for a man who wants to make money in the jewelry business. It will double discount any big city business with the same capital invested. Good reason given for selling out. For other information write to The Leading Jeweler, P. O. Box 99, Columbus, Nebraska. A man who has not got \$4,000 to \$5,000 need not reply.

**BUYERS' DIRECTORY.****NEW YORK.****Assayers and Sweep Smelters.**

**Wundoehl, H.**—Gold and Silver Refiner, Assayer and Sweep Smelter. 21 John Street, N. Y.

**Badges and Medals.**

**Stockwell & Newman**—19 John Street. Manufacturers of Badges, Medals and Presentation Pieces in Gold and Silver. Also Jewelry and Mounters of Diamonds. Designs supplied.

**Band Rings.**

**Knapp, Charles**, 41 Maiden Lane, N. Y. Specialty: Superior Band Rings, also Ring Shanks & Heads for Seal and Diamond Rings.

**Black Onyx Jewelry.**

**Cox & Sedgwick**—Manufacturers of Black Onyx Jewelry, No. 26 John St. New York.

**Lawson, Samuel**—No. 18 John Street. Manufacturer of Black Onyx Jewelry. Coral repaired for the trade. Goods sent on approval to responsible dealers.

**Woglom & Miller**—Manufacturers of (exclusively) Black Onyx Jewelry, 32 & 34 John St., N. Y.

**Blue Enameled Lockets.**

**Bissinger, Philip & Co.**—Importers of Diamonds, Pearls and Precious Stones. Agent for the Bohemian Garnet Goods. Blue Enameled Lockets, 22 John St., N. Y.

**Emrich, I.**—Importer of Blue Enameled Lockets, Ear Drops and all kinds of Enameled Jewelry; also Enamel for Manufacturing purposes. 66 Nassau St., N. Y.

**Hess & Schliesser**—Importers of Diamonds, Fine Jewelry and Novelties in French Goods. Specialties: Gold and Blue Enameled Lockets, Charms and Crosses. 2 John Street.

**Bohemian Garnet Jewelry.**

**Bissinger, Philip & Co.**—Importers of Diamonds, Pearls and Precious Stones. Sole Agent for the Bohemian Garnet Jewelry. Blue Enameled Lockets. 22 John St.

**Emrich, I.**—Importer of Half Pearls and Bohemian Garnet Jewelry. Designs made to order in our European Factory at moderate prices. 66 Nassau St., N. Y.

**Clock Companies.**

**Ansonia Clock Co.**—Manufacturers of every description of Clocks. 11 to 21 Cliff street, New York.

**E. Howard Watch and Clock Co.**—No. 29 Maiden Lane, New York, and 114 Tremont St., Boston.

**Kroeber, F.**—Manufacturer and Dealer in American and French Clocks, No. 14 Cortlandt Street.

**Le Boutillier & Co.**—Importers and Jobbers in French Marble Clocks. 31 and 33 West 23d Street, N. Y.

**New Haven Clock Co.**—16 and 18 Park Place, N. Y.

**Seth Thomas Clock Co.**—20 Murray Street, N. Y.

**Waterbury Clock Co.**—Manufacturers, No. 10 Courtlandt St., N. Y. and No. 63 Washington St., Chicago, Ills.

**Welch, E. N., Manufacturing Co.**—Manufacturers of American Clocks. No. 6 Warren St.

**Wm. L. Gilbert Clock Co.**—No. 6 Murray Street, Manufacturers of Clocks. Factories, Winsted, Conn.

**Cameo Cutters, Etc.**

**Peiter, Theodore**—Cameo and Intaglio Engraver. Patentee of the Cameo-Intaglio. No. 3 Maiden Lane, New York.

**Charms & Gold Watch Keys.**

**Rupp & Held**—Manufacturing Jewelers, Charms and Gold Watch Keys, with French and English Rachets, a specialty. 15 John St., N. Y.

**Crucibles.**

**Berge, J. & H.**—Established 1850. Importers of Sand Crucibles, Covers, Chemical Porcelain, Glassware, and Jewelers' and Assayers' Supplies. 95 John Street, N. Y.

**Cutlery.**

**Harrison Bros. & Howson**—Manufacturers of Fine Ivory and Pearl Table and Pocket Cutlery, Carvers in Cases; Nutpicks, Nutcracks and goods suitable for the jewelry trade. 126 Chambers Street. W. C. Burkinshaw, Sole Agent.

**Diamond Brokers.**

**Anderson, Otis**—Diamond Merchant and Broker, always ready to pay cash for bargains in Diamonds and Precious Stones, 4 & 6 John Street, N. Y.

**Bernhardt, Richard**—Diamond Broker and Importer, 65 Nassau Street (Room 6), N. Y. Paris, 20, rue des Petites-écuries.

**Friend S. & Son**—Brokers and dealers in Diamonds 33 John Street, cor. Nassau St. New York.

**Herbert, R. J.**—Diamond Broker and Dealer. 26 Maiden Lane.

**Diamond Importers.**

**Anrich, E. L.**—Diamonds, 182 and 184 Broadway, cor. John St., N. Y. Cutting Establishment, 133 Water St.

**Bernhard, A. & Co.**—Importers of Diamonds and Manufacturers of First-class Diamond Jewelry, Diamond Settings for Manufacturing Jewelers. Catalogue of Designs for the Trade free of charge. No. 2 Maiden Lane, New York.

**Bissinger, Philip & Co.**—Importers of Diamonds, Pearls and Precious Stones. Agent for the Bohemian Garnet Goods. Blue Enameled Lockets. No. 22 John St., N. Y.

**Bruhl, D. & M.**—Established in 1848. 14 Maiden Lane, N. Y.; 111 Broad Street, Providence, R. I.; 14 Rue Bleue, Paris.

**Brunswick, S. & Co.**—Importers of Diamonds. 17 Maiden Lane, New York. Paris, Rue Lafayette. Amsterdam, Damstraat.

**Citroen, L. B., & Co.**—Diamonds. 21 John St., N. Y. Cutting Works, 57 & 61 Rapenburgerstraat, Amsterdam. House in Paris, 53 Rue de Chateaudun.

**Faulkenau, Oppenheimer & Co.**—Manufacturers. Diamonds and Diamond Jewelry. 40 Maiden Lane, N. Y.

**Fera, Henry**—Importer of Diamonds, and Manufacturer of Fine Diamond Jewelry. 4 & 6 John Street, New York. Amsterdam, Holland, 23 Loojersgracht.

**Fox, M. & Co.**—Importers of Diamonds, Rubies, Sapphires and Fancy Gems. No. 1 Maiden Lane, New York

**Hedges, Wm. S. & Co.**—Importers of Diamonds. No. 170 Broadway, corner Maiden Lane.

**Henle Brothers**—Importers of and Wholesale Dealers in Diamonds only. No. 16 Maiden Lane, N. Y. Paris, 20 Rue Laffitte.

**Hessels, Anthony**—Importer and Dealer in all kinds of Precious Stones. Diamond Cutters and Polishers. 45 John Street, N. Y.

**Kuhn, Doerflinger, & Co.**—Manufacturing Jewelers and Importers of Diamonds, 18 John street, New York

**Leberthon, L. M.**—Importer of Diamonds and Manufacturer of Fine Jewelry. 14 John Street, N. Y.

**Miller Bros.**—Importers of Diamonds and Manufacturers of Fine Diamond Jewelry and Mountings.

**Mulford & Bonnet**—Diamond Importers, No. 21 Maiden Lane, N. Y. City.

**Neresheimer, E. Aug. & Co.**—Importer of Diamonds. No. 21 Maiden Lane, New York.

**Randel, Baremore & Billings**—Importers of Diamonds, corner Maiden Lane and Nassau St.

**Saril, S.**—Importer of Diamonds, 182 Broadway, N. Y. Branch of Vve. H. A. Marchand & Frères, 47 Rue Le Peletier, Paris.

**Saunders & Ives.**—Importers of Diamonds and other Precious Stones. No. 26 Maiden Lane.

**Smith, Alfred H. & Co.**—Importers of Diamonds, No. 182 Broadway.

**Tannenbaum, L. & Co.**—Importers of Diamonds and Precious Stones. Steam Lapidary Works. Oriental Stones Cut and Polished a specialty. 65 Nassau St., N. Y.

**Taylor & Brother.**—Importers of Diamonds and Diamond Jewelry. 860 Broadway.

**Wickham, D. H. & Co.**—Importer of Diamonds. No. 31 Holborn Viaduct, London, 24 Maiden Lane, New York.

**Wolff, G. A.**—Importer of Diamonds, Rubies, Sapphires, Pearls, and other Precious Stones, 65 Maiden Lane, New York. 12 Rue de Chateaudun, Paris.

#### Diamond Jewelry.

**Baldwin, Sexton & Peterson**—Importers of Diamonds and Manufacturers of Diamond Jewelry, 602 and 604 Broadway, N. Y.

**Bornemann, Louis.**—Importer of Diamonds and Manufacturer of Rich Diamond Jewelry, 19 John Street, New York.

**Chalumeau, D.**—Diamond Jeweler and Manufacturer of Mountings. Novelties and Artistic Jewelry. No. 3 Maiden Lane, New York.

**Goldsmith, Ingomar & Co.**—Manufacturers of Diamond Mountings and Diamond Jewelry, 61 Nassau Street, New York.

**Goldsmith & Co.**—Manufacturers of Fine Diamond Mountings and Diamond Jewelry. Lace Pins, Ear Rings and Rings a specialty. 49 Maiden Lane, N. Y.

**Hartje, G. & F.**—Manufacturers of Diamond and Fine Jewelry, 39 Union Square, N. Y.

**Haug, John**—Manufacturer of Fine Diamond Mountings, etc. No. 130 Fulton St., N. Y.

**Heller & Bardel.**—Manufacturers of Diamond and Pearl Jewelry, and Dealers in Diamonds, Pearls, &c. 13 John Street.

**Jeanne Brothers.**—Manufacturers of Diamond Mountings & Rich Jewelry. 1 Maiden Lane.

**Lacroix & Verpillier.**—Manufacturers of Fine Gold Jewelry. Diamonds a specialty. 173 Broadway, N. Y.

**Luthy, A. & Co.**—Manufacturers of Fine Diamond Mountings, Lace Pins, Ear Rings, Rings, Knife Edge Bracelets, Hair Ornaments, etc., a Specialty. 35 Ann Street, corner Nassau Street, N. Y.

**Mitchell, Noah**—Manufacturer of Diamond Jewelry and Diamond Mountings. 52 Maiden Lane, New York.

**Nissen, Ludwig & Co.**—Dealers in Diamonds and Manufacturers of Diamond Mountings. No. 51 Nassau Street, New York, near Maiden Lane.

**Rosswog, C. & Son**—Manufacturers of Rich Diamond Goods. Nos. 5 and 7 Maiden Lane, N. Y.

**Voelker, C. T.**—Manufacturer of 18-k. Diamond Mountings, Diamond Jewelry and Roller Chain Bracelets. 15 Maiden Lane, New York.

**Waterman & Lehmann.**—Manufacturing Jewelers and Dealers in Diamonds. Diamond Work, and Fine fancy Rings a specialty, any piece of single work made to order. 37 Maiden Lane, N. Y.

**Wienhold, J.**—Manufacturer of Fine Jewelry. Diamond Mountings a specialty. 24 John Street.

#### Diamond Cutters.

**Levy, Herman.**—Importer, Cutter and Polisher of Diamonds. 105 Fulton Street, New York.

**Mendes, D. De S.**—Diamond Cutter and Polisher, 113 Nassau St., N. Y. Re-cutting, Repairing and Matching a Specialty.

**Ramsgate, Robert H.**—Diamond Cutter and Polisher; Matching and Repairing a specialty. 16 Maiden Lane, New York.

#### Dials, &c.

**New York Dial Co.**—Manufacturers of Fine Watch Dials. Henry Abbott, Agent, No. 4 Maiden Lane, N. Y.

#### Enameled Clock Dials and Figures.

**Caeser Bros.**—Manufacturers of Enameled Clock Dials, also letters and numbers for signs. 230 and 232 East 25th Street, New York.

#### Enamellers, Etc.

**Nutt, J. D.**—Enameler on Gold, Silver, and Copper. Linen finished Buttons and Studs. Enameling in colors. 32 and 34 John Street, New York.

**Orr, J. C.**—Enameler on Fine Jewelry. Enameled in Colors. Linen Finished Buttons and Studs. Band Bracelets. No. 75 Nassau Street, N. Y.

**Orr, William N.**—Enameler on Fine Jewelry. Masonic Jewels and Badges a specialty. Linen Finished Work. 79 Nassau Street, Room 18, New York.

#### Engravers—Stone Seal, Etc.

**Fackner, Edward**—Carver, Engraver and Chaser on Jewelry and Pencil Cases, lettering, &c., 19 John Street.

**Holland & Gosling**—Stone Seal Engravers. Precious Stones inlaid and encrusted with Diamonds. No. 176 Broadway, New York, (fifth floor per elevator). Cameos cut and repaired.

**Knapp, Chas.** Engraver, Die Sinker & Stamper for Jewelry purposes. Ring Shanks & superior Band rings, 41 Maiden Lane, N. Y.

**Park, Wm.**—The Stone Seal Engraver. Arms, Crests, Monograms, etc., engraved on precious stones, 26 John Street, New York.

**Weston, James F.**—Stone Seal Engraver and incruiter of Precious Stones. Coats of Arms, Masonic, Odd Fellows, and other devices engraved. 32 John Street.

#### Fancy Goods, Clocks, Bronzes, Etc.

**Hinrichs, C. F. A.**—Importer of Fancy Goods, Glassware, China, Clocks, Bronzes, etc. 31 Park Place.

**Le Boutillier & Co.**—Importers of Fancy Goods, Clocks, Bronzes, &c., 33 West 23d Street.

**Straus, L. & Sons**—Importers of Potteries, Faïences, Bisque Figures and Rich Fancy Goods especially adapted for the Jewelry Trade. 40, 42 and 44 Warren Street, New York.

**Taylor & Bro.**—Importers of French Clocks, Bronzes, etc. 676 Broadway, N. Y.

**Young, J. M. & Co.**—Importers of Fine Parian, Lava, and Bisque Statuary, Bohemian, German and English Fancy Goods, 37 & 39 Murray St., New York.

#### Gold and Silver Cane Heads.

**Cuppia, L. A.**—Importer of Filigree Jewelry and Manufacturer of Silver and Gold Cane Heads and Novelties in Silver and Gold Jewelry. 19 Union Square, N. Y.

**Locklin, F. P. & Bro.**—Manufacturers of Gold and Silver Headed Canes. 142 Fulton Street, N. Y.

**Simons, Bro. & Co.**—Manufacturers of Gold Headed Canes. 611 and 613 Sansom street, Philadelphia.

**Smith, Rest Fenner & Co.**—No. 701 Broadway, Makers of Fine Gold and Silver Headed Canes.

#### Gold and Silver Plating, Etc.

**Bantle, A.**—Gold, Silver and Electro-Plating, 130 Fulton and 89 Nassau Streets, cor. Fulton Street, (Room 36,) N. Y. Watch Case Polishing.

**Jeandheur, F. & Son.**—Gold and Silver Electro Platers & Fire Gilders, coloring Etruscan and Gold Jewelry a specialty. 125 Fulton St.

**Klees & Magrath**—Gold and Silver Electro-Platers. Coloring Etruscan and Gold Jewelry a Specialty. 89 Nassau Street, New York.

#### Gold Chains, Etc.

**Beck, J. & Son,** Manufacturers of Fine Gold Chains and Chain Bracelets, 10 Liberty Place, near Maiden Lane, N. Y.

**Carter, Sloan & Co.**—Manufacturers of Fine Gold Chain, 15 Maiden Lane, New York.

**Edge, W. C. & Co.**—Manufacturers of the Celebrated Woven Fabric Gold Chain, No. 15 John Street.

**Kaufmann Bros.**—Manufacturers of Gold Chains, and Chain Bracelets, 12 First Street; Factory, 331 and 333 Bowery, N. Y.

**Kohn, Alois & Co.**—Manufacturers of Gold Chains, 9 Maiden Lane, N. Y.

**Saxton, Smith & Co.**—Manufacturers of Fine Gold Chain, No. 14 John Street, N. Y.

**Schlag, Chas.**—(Late Nordt & Schlag), Manufacturer of Gold Chains, Chain Bracelets and Fine Jewelry. 177 Broadway, New York. All kinds of Jobbing promptly attended to.

**Smith, W. & Co.**—Manufacturers of Gold and Silver Chains, Jewelry, etc. No. 25 Maiden Lane, N. Y.

#### Gold Pens, Etc.

**Alkin, Lambert & Co.**—Manufacturers of Choice Gold Pens, Cases, Holders, Toothpicks, etc., 23 Maiden Lane, N. Y.

**Faber, Eberhard.**—Manufacturer of 16-karat Gold Pens and Pencil Cases. Nos. 718 and 720 Broadway, N. Y.

**Fairchild, Leroy C. & Co.**—No. 10 Maiden Lane, New York. Manufacturers of Gold Pens, Pencils, etc.

**Fairchild, Leroy W.**—Manufacturer of Gold Pens, Pencil Cases, Tooth Picks and Novelties in Charms. No. 18 John St., N. Y.

**Foley, John**—Manufacturer of Fine Gold Pens, Pencils and Charms. 2 Astor House, N. Y.

**Hicks, W. S.**—Established 1848. Manufacturer of Fine Gold Pens, Pencil Cases, Tooth Picks, and Charm Novelties of every description. No. 20 Maiden Lane.

**Johnson, E. S. & Co.**—Manufacturers of Gold Pens, Pen Holders and Pencils. Cor. Maiden Lane and Nassau Street, New York.

**Smith, H. M. & Co.**—Manufacturers of Gold Pens and Holders, Tooth Picks, Pencils, etc. Sole Manufacturers of Sprague's Patent Gold Fountain Pen. Importers of Nickel and Silver Watches. 173 Broadway, New York.

**Gold Rings.**

- Barnet Bros.**—Manufacturers of Stone and Seal Rings, 15 John Street, New York. Factory, Newark, N. J.
- Bowden, J. B. & Co.**—Manufacturing Jeweler.—Solid Gold Rings a specialty, 1 Maiden Lane.
- Cable, Geo. W.**—Manufacturing Jeweler. Plain and Band Rings a Specialty. No. 52 Maiden Lane, N. Y.
- Dattelbaum & Friedman**—Manufacturers of Fine Cameo and Seal Rings, all kinds of Fancy Rings and Diamond Mountings. 10 Maiden Lane.
- Ely, W. H.**—Manufacturer of Solid Gold Rings of every description. No. 58 Nassau Street.
- Engelfried, Braun & Weidmann**—Manufacturing Jewelers, 128 Fulton Street corner Nassau, New York. Commercial Building, room 31. Rings a specialty.
- Henrich, R.**—No. 35 Maiden Lane, Manufacturer of Gold Rings; also Patentee and Manufacturer of the Celebrated Self-Sizing Ring
- Hutchison & Huestis**—Makers of Solid Gold Rings. Quality guaranteed. For the Jobbing Trade only. 196 Broadway, N. Y.
- Kroll, H.**—Manufacturing Jeweler. 78 Nassau Street, New York. Specialty: Solid Gold Stone Rings. All kinds of Fine Jewelry made to order, also Repairing for the Trade.
- Müller, H.**—111 Nassau St., N. Y., Manufacturer of Fancy and Seal Rings of every description. Plain Gold and Chased Band Rings in 10, 14 & 18 Kt.
- Ostby & Barton**—Manufacturers of Plain and Engraved Solid Gold Band Rings. Office, 176 Broadway, N. Y. Factory, 80 Clifford Street, Providence, R. I.
- Peckham, Wm. H.**—Manufacturers of Solid Gold Seamless Rings, and Fancy Embossed Rings, Patent Spectacles, Jewelry, etc. No. 4 Liberty Place N. Y.
- Radler, K.**—Manufacturing Jeweler. Gold Rings and Locketts a specialty. No. 179 Broadway, New York.
- Sauter, L.**—No. 1 Maiden Lane, New York, Manufacturer of Stone Rings of every description, as Diamond, Cameo, Onyx Turquoise, etc., Scarf Pins, Scarf Rings, Studs and Buttons.
- Shafer & Douglass.**—Manufacturers of all kinds of Seal, Stone, Turquoise, and fancy rings. No. 7 Maiden Lane, N. Y.
- Thuerner & Church**—Manufacturers of Fine Gold Rings. No. 9 Maiden Lane, N. Y.

**Hair Jewelry.**

- Moutoux, Wm. E. & Co.**—Manufacturers of Fine Hair Mountings in Gold. Grand catalogues for the trade. 81 Nassau St., Rooms 1 and 2. Finest work and lowest prices
- Sauter, L.**—Manufacturer of Fine Gold and Hair Jewelry and Device Work. Pattern Book sent on application. No. 1 Maiden Lane, N. Y.
- Schwencke O.**—Manufacturer of Fine Hair Jewelry Orders from the country promptly attended to. No. 43 Maiden Lane.

**Jewelry Cases, Fancy Boxes, Etc.**

- American Morocco Case Co.**—7 & 9 Bond St., N. Y., make a specialty of Rich Jewelry, Silverware Cases and Improved Trays for Watches, Rings, &c. Patent Watch Blocks to fit all sizes.
- Braun, Chr. E.**—Manufacturer of Fine Jewelry Boxes and Trays for Show Cases and Trunks. No. 62 Chatham Street, New York. Trays for Show Cases and Trunks a Specialty.
- Bricka, C. A. & Co.**—Manufacturers of Morocco Cases for Cutlery, Silverware, Jewelry, etc. Sample Cards and Rolls. Cases in Rosewood, Black Walnut, etc. 52 Nassau Street, New York.
- Dannison Mfg Co.**—Manufacturers of Morocco, Plush and Velvet Jewelry and Silverware cases. New York, Boston, Philadelphia, Chicago, Cincinnati and St. Louis.
- Haensler, Chas. C.**—Manufacturer of Fine Morocco Cases for Jewelry and Silverware. Toilet Boxes, etc. Trays for Show Cases and Windows. 14 John Street, New York.

**Hebbard & Brother**—Manufacturers of Jewelry and Silver Ware Cases, and Fancy Wood Chests for Tea Sets and Flat Ware. 860 Broadway, New York.

**Kohn, Solomon**—Manufacturer of Fine Morocco Cases for Jewelry, Watches, etc. 43 Maiden Lane, New York.

**Lauten, Edw. A. & Co.**—No. 4 Great Jones St., Manufacturers of Fine Velvet, Brocade, Plush and Morocco Boxes, Patent Ring, Ear Ring and Gent's Scarf Pin Trays, Patent Watch and Bracelet Blocks, Window Decorations, etc.

**Loehr & Koerner**—Manufacturers of Morocco, Velvet, Satin, Jewelry, Watches and Silverware Cases, Jewel, Work Boxes, etc., Fancy Trays and Store Fittings to order. 96 Liberty St.

**New York Morocco Case Co.**—Cases for Jewelry, Watches, Silverware. Boxes and Trays for Jewelers' Travelers. Show Cases and Window Fittings. No. 69 Nassau Street, New York.

**Schwarz, N.**—Manufacturer of fine Cases for Jewelry and Silverware. 866 Broadway, New York.

**Welch & Miller**—169 Broadway. Manufacturers of fine Morocco, Velvet, Russia, Brocade and Plush Jewelry Cases. Trays of every description; Jeweler's Cotton and Twine.

**Wiggers & Froelick**—No. 60 Nassau street—Manufacturers of Cases for Jewelry, &c., of every description. Trays for Show-cases, Stands for Show-windows, etc.

**Jewelers' Findings.**

- Dennison Mfg Co.**—Paper Jewelry Boxes, cards, tags, pink and white cotton, etc. etc. New York, Boston, Chicago, Cincinnati, Philadelphia, St. Louis.
- Ettlinger, L., & Sons**—Makers of Cases and Paper Boxes of every description for Jewelers and Silversmiths. Fine Cases and Trays to order a specialty; also Cards, Tags, Cotton, Tissue Paper, &c. 80 Nassau St., N. Y.
- Lehmann, Ludwig.**—Manufacturer of Jewelers' Findings. 122 Fulton St., near Nassau, N. Y.
- Valfer, S. & Co.**—Manufacturers and Dealers in Jewelers' Boxes, Tags, Cards, Paper and Findings. Trays a specialty. Fancy Ornaments for Show Windows. 66 Nassau street, New York.

**Jewelry Manufacturers.**

- Aikin, Lambert & Co.**—Manufacturers General stock of Reliable Jewelry, 23 Maiden Lane.
- Alling, Isaac A. & Co.**—Manufacturers of Fine Gold Jewelry. Specialties: Wire Bracelets, Bangles, American Lever Sleeve Buttons. Bryant Building, Nassau and Liberty Streets, N. Y. Factory, Newark, N. J.
- Baldwin, Sexton & Peterson**—Manufacturers of Rich Jewelry, 692 and 694 Broadway, N. Y.
- Ball, W. H. & Co.**—Manufacturers of Gold Jewelry. Bracelets and Bangles of all kinds a specialty. 9 John Street, N. Y.
- Barthman, Straat & Co.**—Manufacturers of Fine Jewelry. Roman Goods, Rings, Diamonds. No. 43 Maiden Lane.
- Bissinger, Philip & Co.**—Importers of Diamonds, Pearls and Precious Stones. Sole Agents for the Bohemian Garnet Jewelry, Blue Enameled Lockets. 22 John St., N. Y.
- Bonner & Abramovitz**—Manufacturers of Diamond Jewelry. Specialty, Ring Mountings. 128 Fulton Street, Room 30, New York.
- Brown, Thos. G. & Sons**—Man'rs of Rich Jewelry Necklaces, Locketts, Bracelets, Sleeve Buttons, etc., 860 Broadway, N. Y.
- Bryant & Bentley**—Manufacturing Jewelers. Rings a specialty. 12 Maiden Lane
- Carter, Sloan & Co.**—Manufacturing Jewelers, 15 Maiden Lane, New York.
- Champenois & Co.**—No. 5 Maiden Lane, manufacturers of Engraved and Enameled Gold goods, in Sets, Ear Knobs, Bracelets, Studs, Lace and Shawl Pins, Jet cluster and Onyx goods, also "Best Lever" Sleeve Buttons.
- Chatellier, Joseph F.**—Manufacturing Jeweler, No. 694 Broadway, N. Y.

**Churchill, Lewis & Co.**—Manufacturers of Fine Jewelry. 692 Broadway, cor. Fourth St., N. Y.

**Cook, George W.**—Manufacturer of Fine Jewelry and Locketts, 191 Broadway (over Mercantile Bank,) N. Y.

**Cottle S. Co.**—Manufacturers of Fine Jewelry. 860 Broadway, N. Y.

**Cox & Sedgwick**—Manufacturers of fine Onyx and Colored Jewelry. 26 John St., New York

**Day & Clark**—Manufacturers of Fine Jewelry, Lace Pins, Ear Rings, Studs, Locketts, &c., 10 Maiden Lane, New York.

**Geoffroy, Arthur R. & Co.**—Manufacturing Jewelers. Novelties in Diamond Goods. No. 23 Maiden Lane, N. Y.

**Greene Wm. C. & Co.**—Goldsmiths; Manufacturers of Rich Sets in Taper Wire Coral. Office, 192 Broadway.

**Griffith, H.**—Manufacturing Jeweler. Gold and Plated Jewelry. Scarf Pins a specialty. Nutry Alley, near Concord St., Brooklyn, N. Y.

**Groeschel & Rosman**—Manufacturers of Fine Jewelry. No. 27 John Street, N. Y.

**Hartmann, P.**—Manufacturer & Importer of Fine Gold, Diamond, and Filigree Silver Jewelry, No. 36 Maiden Lane. P. O. Box 2,454.

**Hedges, A. J. & Co.**—Manufacturing Jewelers, 6 Maiden Lane.

**Henderson & Winter**—Jewelers, No. 15 Maiden Lane, New York. Specialties—Stone, Cameo, Onyx, Amethyst, Topaz, Pearl and Turquoise Rings.

**Hunt & Owen.**—Manufacturing Jewelers. Office 3 Maiden Lane.

**Jandorf, P. & Bro.**—Manufacturing and Wholesale Jewelers—all grades. Prompt Attention to Orders. We issue no catalogue. 196 Broadway, N. Y.

**Kipper, Vogel & Co.**—Manufacturing Jewelers, 17 Maiden Lane, New York.

**Krementz & Co.**—Manufacturing Jewelers, No. 182 Broadway, N. Y.

**Kuhn, Doerflinger & Co.**—Manufacturers of Enamelled and Roman Band Bracelets, also Fine Locketts Pendants and Lace Pins. 18 John street.

**Miller Bros.**—Manufacturers of Fine Jewelry, Diamond Goods, Sets, Lace Pins, Ear Rings, Scarf Pins, Sleeve Buttons, Studs, etc. 7 Maiden Lane, N. Y.

**Moore & Horton.**—11 Maiden Lane, Manufacturing Jewelers, Rings, Studs, Collars and Sleeve Buttons, Pins, Ear-rings, &c.

**Muhr's, H., Sons.**—Manufacturing Jewelers. Solid Gold and Filled Rings a specialty. Also Manufacturers of the celebrated Crown Filled Watch Case. 16 Maiden Lane, N. Y.

**Mulford & Bonnet**—No. 21 Maiden Lane, New York.

**Owen, G. & S. & Co.**—Manufacturing Jewelers. Office, No. 3 Maiden Lane.

**Richardson, Enos & Co.**—Manufacturers of Fine Gold Jewelry, Gold Chains, Locketts, Crosses and Necklaces. Colored and Etruscan Work. No. 23 Maiden Lane, New York.

**Richardson, J. W. & Co.**—Manufacturers of Jewelry. Masonic and other Emblems. 196 Broadway, N. Y. Manufactory, Providence, R. I.

**Riley, J. A. & Co.**—Manufacturing Jewelers. Etruscan Gold and Roman Bracelets, Lace Pins, Ear Rings, Scarf Pins, Brooch Pins, etc. No. 860 Broadway, N. Y.

**Ripley, Howland & Co.**—Manufacturers of Fine Jewelry and Platinum Tipped Diamond Settings. No. 17 Maiden Lane, N. Y.

**Schwencke, Wm.**—Manufacturing and Jobbing Jeweler. Repairing a specialty. Orders promptly attended to. No. 43 Maiden Lane, N. Y.

**Sexton & Cole**—Manufacturing Jewelers, Colored Gold and Onyx Goods a specialty. No. 30 Maiden Lane.

**Sheafer, W. H. & Co.**—Manufacturing Jewelers, Specialty Bangles and Bracelets, 15 John St., N. Y.

**Stites' Sons, E.**—Manufacturers of Fine Jewelry: No. 14 John Street, N. Y.

**Street, Geo. O. & Sons.**—Established 1837. Makers of Fine Jewelry, strictly first-class goods of our own make. No. 15 John Street, New York.

**Thoma, Ernest**—Manufacturer of Fine Jewelry, Sleeve Buttons, Rings, Ear-rings, &c. No. 173 Broadway, N. Y. Factory, Hackensack, N. J.

**Ward, Thos. M.**—Manufacturer of Fine Jewelry. Diamond Mountings a specialty. No. 25 John Street, N. Y.

**Wienhold, J.**—Manufacturer of Fine Jewelry. Diamond Mountings a Specialty. 24 John St.

**Woglom & Miller**—Manufacturers of Black Onyx Goods exclusively. 32 & 34 John Street, N. Y.

#### Jewelry—Rolled Plate.

**Blackinton, W. & S.**—Manufacturers of the W. & S. B. Rolled Plated Chains. No. 11 Maiden Lane.

**Frick, John & Co.**—Fine Rolled Plate Jewelry of all kinds. Repairing of every description. 21 and 23 Maiden Lane, N. Y.

**Mauran, J. T.**—Manufacturer of Fine Rolled Plate Jewelry, No. 15 Maiden Lane, N. Y.

**Richards, E. Ira & Co.**—Manufacturers of Fine Rolled Plate Jewelry, No. 200 Broadway, N. Y.

#### Jewelers' Tools, etc.

**Fisher, James J.**—Dealer in Watchmakers' and Jewelers' Materials, Files, Tools, Silk Guards, Spectacles, etc. 695 and 697 Broadway, N. Y.

**Friedenthal, A. & Co.**—Importers and jobbers of Watchmakers' and Jewelers' Tools, Materials, etc. 43 Maiden Lane, N. Y.

**Friedlander, R. & L.**—Importers of Watchmakers' Tools and Materials. 65 & 67 Nassau Street. Branch Office, 264 Bowery.

**Koester, C. F.**—Importer and Manufacturer of Fine Tools, Files and Polishing Materials for Jewelers, Watch Case Makers, etc. 33 John St.

**Kurtz, F. P.**—Manufacturer of Jewelers Machinery, Tools, Rolling Mills, Presses, Polishing Lathes, &c. 97 Cliff St., N. Y.

**Levy, Dreyfus & Co.**—Importers and Jobbers of Watchmakers' and Jewelers tools and materials of every description. 11 Maiden Lane, N. Y.

**Reichhelm, E. P. & Co.**—Importers of Jewelers' Tools, Files, etc. Manufacturers of Brushes and Buffing wheels; also Patent Gas Furnaces for Melting, Plating, Enamelling, Annealing, etc. 80 Nassau St., N. Y.

#### Lapidaries.

**Fox, M. & Co.**—Practical Lapidaries, No. 1 Maiden Lane, New York.

**Graham & Co.**—Practical Lapidaries, Cutters and Polishers of all kinds of Precious Stones, Emeralds, Rubies, Sapphires, etc. Miner's Relics Cut, Polished and Mounted. Locket Glasses, 80 Nassau St., N. Y.

**Kordmann & Michel.**—Lapidaries. Dealers in Precious Stones. Cutting and Polishing Rubies, Sapphires and other Gems a specialty. Drilling done promptly. 59 Nassau St., N. Y.

#### Masonic Jewelry.

**Luther, John F.**—79 Nassau Street. Manufacturer of Fine Presentation Jewels for all Societies. Knights Templars, Crosses, Badges, &c.

**Wilkinson, C. B.**—Manufacturing Jeweler, 8 John St., N. Y. Medals, Badges and Masonic Jewelry, a specialty. Designs furnished free upon application.

#### Musical Boxes.

**Pailiard, M. J. & Co.**—Manufacturers of Musical Boxes and Musical Novelties. Warerooms, 680 Broadway, N. Y.

#### Optical Goods.

**Friedlander, R. & L.**—65 and 67 Nassau Street. Dealers in Optical Goods.

**Spencer Optical Manufacturing Co.**—Manufacturers of Spectacles and Eye-Glasses. 13 Maiden Lane, N. Y.

#### Opticians.

**Burbank Man'g Co.**—Manufacturers of Spectacles and Eye Glasses of all descriptions, in gold, silver, etc., 14 Maiden Lane, N. Y.

**DaBois, Geo. W. & Co.**—Importers of Watches and Optical Goods. 36 Maiden Lane, N. Y.

**Levy, Dreyfus & Co.**—Importers of Spectacles and Eye Glasses and Optical Instruments of every description. No. 11 Maiden Lane, N. Y.

**Lorsch, Albert**—Manufacturer of the Patent Accommodating Spectacles and Eye Glasses in Gold, Silver and Steel, and other Optical Goods, 37 Maiden Lane, N. Y.

**Spencer Optical Manufacturing Co.**—Gold, Silver, Steel, Nickel and Plated Spectacles; Gold, Celluloid, Steel, Nickel and Rubber Eye Glass and Opera Glasses. 13 Maiden Lane, N. Y.

**Todd, James W.**—No. 20 Maiden Lane, N. Y. Wholesale Dealer in Optical Goods.

#### Paper Boxes.

**Lehmann, Ludwig.**—Manufacturer of Jewelers' Findings. 122 Fulton St., near Nassau, N. Y.

**Waterbury Paper and Box Co.**, 27 to 35 Canal St., Waterbury, Conn., Manufacture Jewelers' and Silversmiths' Fine Paper Boxes. Quality guaranteed to be equal to the best made.

#### Polishers and Lappers.

**Klees & Co.**—Late Abels, Polishers and Lappers of Fine Jewelry. 89 Nassau St., Room 17, N. Y.

#### Precious Stones, &c.

**Bishop, Victor & Co.**—33 Maiden Lane, Importers of Precious Stones, Cameos, &c. Also Manufacturers of Coral Jewelry.

**Bissinger, Philip & Co.**—Importer of Diamonds, Pearls and Precious Stones. Agent for the Bohemian Garnet Goods. Blue Enamelled Locket. No. 22 John St., N. Y.

**Breidenbach, R. A.**—Importer of Black Onyx, Diamonds, Pearls, Turquoise, Cameos, Sardonyx, Amethysts, Garnets, Topaz, Opals, Rubies, Sapphires, Hematite Balls, Foil Brilliants, Cat's-Eyes, Tiger Eyes, Doublets, Cabinet Specimens, etc. 85 Nassau Street, New York.

**Daue, Wm. & Co.**—Importer of Precious and Imitation Stones. No. 202 Broadway New York.

**Fox, M. & Co.**—Importers of Diamonds and other Precious Stones, No. 1 Maiden Lane, N. Y.

**Gruet, Jules.**—Importer of all Grades of Real and Imitation Stones. 14 John St., N. Y.

**Hahn & Co.**—Importers of Precious Stones, Cameos, Onyx, Pearls, Intaglios, Amethysts, Garnets, etc. 64 Nassau Street, New York.

**Kahn, L. & M. & Co.**—Importers of precious and imitation stones. 10 Maiden Lane, N. Y.

**Kipling, E. E.**—Importer of Precious and Imitation Stones. Manufacturer of the Patent Foil Solid Metal Back Rhine Stone Brilliant. No. 6 Maiden Lane, N. Y.

**Kipling, R. A.**—Precious and Imitation Stones, No. 24 Maiden Lane, N. Y. Manufacturer Cameos, Agates, Onyx, Etc., Oberstein, Germany. Commission Merchant, 49 Rue De L'Echiquier, Paris.

**Lorsch, Albert**—Importer of Precious Stones, 37 Maiden Lane, N. Y.

**Stirn, Oppenheimer & Co.**—Importers of Black Onyx, Cameos, Turquoise, Sardonyx, Garnets, Rubies and all other Precious and Imitation Stones. German, French and Vienna Novelties, 3 Maiden Lane, N. Y.

#### Safes.

**Butler, W. H.**—Fire and Burglar Proof Safes, 291 Broadway, N. Y.

#### Silverware.

**Gorham Manufacturing Co.**—Union Square.

**Knowles, J. B. & S. M.**—Manufacturers of Sterling Silverware, 20 Maiden Lane, N. Y. Factory, Providence, R. I.

**Shiebler, Geo. W.**—Manufacturer of Sterling Silverware. No. 8 Liberty Place, near Maiden Lane, N. Y.

**Whiting Manufacturing Co.**—Makers of Sterling Silver Ware. Broadway cor. 4th Street, N. Y.

**Wood & Hughes.**—Manufacturers of Fine Silverware. 16 John Street, N. Y.

#### Silver Filigree Jewelry.

**Cuppia, L. A.**—Manufacturer of Solid Silver Novelties, and Importer of Silver Filigree, 19 Union Square.

**Francesconi, Guido**—Importer of Silver Filigree Jewelry, 196 Broadway, New York.

**Hartmann, P.**—Manufacturer of Silver Filigree Jewelry. 36 Maiden Lane, N. Y.

#### Silver Plated Ware.

**Manhattan Silver Plate Co.**—Manufacturers of Silver Plated Ware. Showrooms, 23 John St. Factory, 301 to 305 East 22d St., cor. 2d Ave. Address all communications to Factory.

**Middletown Plate Co.**—Manufacturers of Superior Electro-Plate. Factories, Middletown, Conn., salesroom, 13 John Street.

**Rogers, Smith & Co.**—Manufacturers of Fine Electro Plated Ware. No. 46 E. 14th St., N. Y.

**Rogers & Brother**—Manufacturers of Electro-Plated Flat and Hollow Ware. 690 Broadway, N. Y.

**Schade, Henry.**—Manufacturer of White Metal and Plated Ware. Office, 26 John Street, N. Y. Price list and catalogue furnished on application.

**Simpson, Hall, Miller & Co.**—Manufacturers of fine Silver-Plated Ware. No. 36 E. 14th Street.

**The Derby Silver Co.**—Manufacturers of Finest Quadruple Silver Plated Ware, Birmingham, Conn. New York office, 25 Maiden Lane.

**Webster, E. G. & Bro.**—Manufacturers of Fine Silver-Plated Ware. Office and warerooms, 14 Maiden Lane, N. Y.

#### Show Cases, Etc.

**Smith, B. & W. B.**—Manufacturers of Patent Improved Dust Proof Show Cases, with Perpendicular Sliding Doors, No. 220 W. 29th St., N. Y.

#### Spectacle Case Manufacturers.

**Bertine, P. D.**—Manufacturer of Spectacle and Eye-Glass Cases, 139 William Street, near Fulton St., New York.

**Koenen, A. & Bro.**—Manufacturers of Leather Spectacle and Eye-Glass Cases for the Jobbing Trade only. 81 Nassau St., N. Y.

**Spencer Optical Manufacturing Co.**—Manufacturers of Spectacle and Eye-Glass Cases. 13 Maiden Lane, N. Y.

#### Stem Winding Attachments.

**Abbott, Henry** Maker of Stem Winding Attachments, No. 4 Maiden Lane, N. Y.

#### Swivels and Spring Rings.

**Schwartz, V. & Co.**—Manufacturers of Gold Swivel and Chain Trimmings. 33 Barclay Street, New York.

#### Thermometers, Etc.

**Tagliabue, Giuseppe.**—manufacturer of Thermometers, Barometers and Hydrometers. Patentee and sole manufacturer of the U. S. Standard Hydrometer. 302 Pearl Street, near Beekman.

#### Thimble Manufacturers.

**Burbank Manufg Co.**—Manufacturers of Gold and Silver Thimbles, 14 Maiden Lane, N. Y.

**Ketcham & McDougall.**—Improved Gold and Silver Thimbles, Bryant Building, N. Y.

**Simons Bro. & Co.**—Manufacturers of Gold and Silver Thimbles, 611 and 613 Sansom Street, Philadelphia.

**Woglom & Miller.**—Sole Agents for the "Prime" Thimbles in Gold and Silver, manufactured by Ezra C. Prime. 34 John Street, N. Y.

#### Trunks.

**Crouch & Fitzgerald**—Manufacturers of Trunks and Articles for Travelers' use. 1 Cortlandt St., 556 Broadway, and 723 Sixth Ave., N. Y.

#### Watch Companies.

**American Watch Co.**—Robbins & Appleton, No. 5 Bond Street, N. Y.

**Illinois Watch Co.**—Springfield, Illinois. 21 Maiden Lane, N. Y. and 71 Washington Street, Chicago, Ills.

**The E. Howard Watch and Clock Co.**—Cor. Maiden Lane and Nassau Street, N. Y.

**Waterbury Watch Co.**—Manufacturers of the Waterbury Watch. Factory, Waterbury. Office, 52 Maiden Lane, N. Y.

#### Watch and Chronometer Jewelers.

**Queen, James.**—Watch and Chronometer Jeweler and Pallet Maker, 78 Nassau Street, room 8. Pivots inserted in Pinions, Balance, Staffs, etc.

**Robert, Henry L.**—Practical Chronometer and Watch Jeweler and Adjuster. 71 Nassau Street. Pallet and Hole Jewels for Chronometer Watches done in the best manner.

**Wennstrom, John.**—Watch, Chronometer and Clock Jeweling, Jewel Gauges, Ruby and Sapphire Draw Plates; Diamond Charged Polishing Stones for Jewel Settings; Pivots inserted in Pinions, 2 Dutch Street, N. Y.



**Watch Importers, Etc.**

- Abry, Chas. Leo**—Importer and Manufacturer of Swiss Watches of all grades. 63 Nassau Street.
- Aikin, Lambert & Co.**—Importers of Watches. Sole Agents for Paul Breton & Chas. Latour, Geneva. A general line of reliable Swiss Watches, Watch Cases, etc. 23 Maiden Lane, N. Y.
- Bartens & Rice**—20 John Street, Importers of Watches and sole agents in the United States for the celebrated Nicole, Nielsen & Co. Watches.
- Cross & Beguelin.**—Importers of Watches, Watch Tools and Materials, dealers in American Watches, No. 21 Maiden Lane, N. Y.
- Droz, Henry E.**—Importer of Watches, and Watch Case Manufacturer. Agent for the "E. Perre- gaux" Watch, and jobber in American Watches No. 92 Fulton Street, N. Y.
- Freund Max & Co.**—Importers of Watches, Jew- elry and Precious Stones, 8 Maiden Lane, N. Y.
- Gagnebin, Chas.**—Importer of all kinds of Swiss, and Dealer in American Watches. 4 Maiden Lane, N. Y. Agent for Ulysse Breting's Fine Chronometers, Chronographs, Anchors, &c.
- Gallet, Julien.**—Importer of Watches. No. 1 Maiden Lane.
- Ginnel, Henry**—Importer of Watches, Tools and Materials, 31 Maiden Lane, N. Y. P.O. Box 2967
- Hyde's Sons, John E.**—Wholesale Commission Agents, only for Jules Jurgensen, of Copenhagen; Jules Monard, of Geneva; and for other makers of all qualities of Watches, 22 Maiden Lane.
- Keller, L. H. & Co.**—Successors to G. A. Hugue- nin, Importers of Fine Watch and French Clock Materials, No. 64 Nassau Street, N. Y.
- Mathey Bros. & Mathez.**—Importers of Fine Watches and Sole Agents for the **H. L. Matile's** Watches. No. 16 Maiden Lane.
- Robert, J. Eugene**—No. 30 Maiden Lane, New York. Agent for Louis Audemar's celebrated watches.
- Schumann, Chas. W.**—No. 24 John Street, New York. Importer of Fine Diamonds, Watches, etc. Sole Agent in the U. S. for the celebrated "Lange" Dresden Watch.
- Schwob, Adolphe**—Manufacturer and Importer of Watches, 5 Maiden Lane, N. Y.
- Strasburger, Louis & Co.**—Importers and Makers of Watches of every description, 15 Maiden Lane.

**Watch Cases.**

- Dueber Watch Case Mfg Co.**—Manufacturers of Gold and Silver Watch Cases. Bryant Building, N. Y. Factory, Newport, Ky.
- Fahys, Joseph**—Manufacturer of Watch Cases and Dealer in American Movements, 38 Maiden Lane.
- Glatz, Chas.**—Manufacturer of Silver Watch Cases. Bryant Building, cor. Nassau and Liberty Sts.
- Keller & Untermeyer.**—Manufacturers of Watch Cases with Raised Gold Ornaments. 9 Maiden Lane, N. Y.
- Ladd Watch Case Co.**—Manufacturers of the Ladd Patent Stiffened Gold Watch Cases, etc., 11 Maiden Lane, N. Y. Factory, 58 Eddy Street, Providence, R. I.
- Martins & Tissot**—Manufacturers of Gold Watch Cases. No. 15 Maiden Lane, N. Y.
- The Brooklyn Watch Case Co.**—Manufacturers of the celebrated Eagle Case. 40 Maiden Lane.
- Willemin Watch Case Co.**—Makers of Gold Watch Cases. Raised Gold Ornamentation and Jurgensen style of Engine Turning. 109 Sands Street, Brooklyn, N. Y. 16 Maiden Lane, N. Y.

**Watch and Chronometer Repairers.**

- Cerf, B.**—Practical Watchmaker and Repairer, No. 10 John Street, N. Y. Repairing and adjusting of Fine Watches done for the trade. All kinds of escape and stem-winding wheels cut to order.
- Goepf, Frederick A.**—Practical Watchmaker. Repairing of every description for the Trade. 25 Maiden Lane, N. Y. In office of H. Garland, Engraver.
- Heinrich, H. H. & Co.**—Sole Manufacturers of H. H. Heinrich's Patent Auxiliary Balance, and Adjusters and Repairers of Fine Watches and Chronometers. 18 John Street, N. Y.
- La Croix, J. H.**—(Late with Benedict's Time,) Watch and Clock Maker, 21 John Street, N. Y. Clocks of every description Repaired for the Trade.
- Lesperance, Theo.**—Watchmaker and Wheel Cut- ter. No. 1 Maiden Lane, New York. With Julien Gallet.

**Watch Case Repairers.**

- Feinier, Joseph A.**—Watch Case Maker and Gen- eral Repairer. Specialty in fine Gold and Silver Cases. Jobbing promptly attended to. Nos. 4 and 6 John St., N. Y.
- Tarbox, Hiram**—Watch Case Repairing, Springing, Polishing and Engine Turning. 1874 North Fourth Avenue, bet. 176th and 177th Sts., N. Y. Express Packages should be sent to 92 Fulton Street.

**Watch Glasses, Shades, Etc.**

- Brown, Edwin H.**—No. 85 Nassau Street, Imported and Own Manufacture Watch Glasses, Flat, Flat Concave, Concave, Convex and fine Genevas. Fine fitting solicited.

**Watches, Diamonds and Jewelry.**

- Alford, C. G. & Co.**—Manufacturers. General line fine and Reliable Goods. Specialties in Onyx Goods and Chain. 200 Broadway, New York.
- Cohn, J. J.**—Importer and Manufacturer of Whitby Jet, Rubber and Pearl goods. Gold and Rolled-plate Jewelry, etc. 12 Maiden Lane, New York.
- Durfey & Reynolds**—Successors to Durfey & Shiebler, Watches, Diamonds, Jewelry. No. 9 John Street, (up-stairs) New York.
- Friedman, Saml.**—Wholesale Dealer in Watches and Jewelry, 42 Maiden Lane, N. Y.
- Goddard, John M.**—Manufacturing Jeweler,— Seal Rings and Fine Lockets a specialty, No. 3 Maiden Lane, N. Y.
- Greason J. R. & Co.**—Successors to Arthur, Rum- rill & Co., 182 Broadway. Manufacturers of Fine Jewelry and Gold Chains, also Diamond Mount- ings.
- Haskell, H. C.**—Manufacturing Jeweler. Seal Rings a specialty. Special attention to Jobbing of every description. 12 John Street.
- Herzog, Louis & Co.**—Importers of Watches, Dealers in Diamonds and Jewelry, 52 Maiden Lane, N. Y.
- Hirsch Bros.**—Dealers in Watches and Diamonds and Manufacturers of Jewelry, No. 23 Maiden Lane, N. Y.
- Jandorf, P. & Bro.**—Importers of Watches and Jewelry, 196 Broadway.
- Kennedy, Frank S.**—Manufacturer and Wholesale Dealer in Jewelry and Gold and Silver Thimbles. No. 13 Maiden Lane, New York.
- Lissauer & Sondheim**—Wholesale Jewelers and Jobbers in American Watches, No. 12 Maiden Lane, N. Y.
- Marx, Kossuth & Co.**—Importers of Watches and Dealers in Jewelry. 39 Maiden Lane, N. Y.
- May, Henry**—Importer and Wholesale Dealer in Watches and Diamonds, and Manufacturing Jew- eler. 19 John St., N. Y.
- Mayer, B.**—Manufacturer of Fine Jewelry, and Dealer in Watches, 71 Nassau street, cor. John street, New York.
- Myers, S. F. & Co.**—Manufacturing and Whole- sale Jewelers—all grades. Importers of Watches. Illustrated Catalogue to the trade. 179 Broad- way, N. Y.
- Oppenheimer Bros. & Veith,**—Dealers in Watches and Diamonds, and Manufacturing Jewelers, No. 35 Maiden Lane.
- Scott, J. T. & Co.**—Importers of Watches, and Manufacturers of Jewelry, and Jobbers of all Grades of American Watches, 4 Maiden Lane.
- Smith & Knapp**—Wholesale Dealers in American and Swiss Watches, Diamonds, Gold and Plated Jewelry and Gold Chain. 182 Broadway, N. Y.
- Steele, J. W.**—Successor to Brainerd, Steele & Co., Manufacturer of Fine Jewelry and Brainerd's Patent Lockets. No. 9 Maiden Lane, N. Y.
- Stern Brothers & Co.**—Importers of Swiss Watches and wholesale dealers in American Watches, &c., 39 Maiden Lane.
- Stern & Stern**—Dealers in Watches, Jewelry and Diamonds. No. 6 Maiden Lane, N. Y.
- Stites, D. H. & Son**—Manufacturers of Fine Jewelry, Rolled Plated Goods and Chains, Parisian Diamond Rings, Studs and Earrings a specialty. 41 Maiden Lane, N. Y.
- Strauss, Jacob.**—Full Line of Gold and Plated Jewelry, and Importer of Watches. 18 John Street, New York.
- Thrall, E. A.**—Wholesale Dealer in Watches and Jewelry. No. 1 Maiden Lane, N. Y.

**Trier Bros.**—Importers of Garnet, Whitby Jet and Amber Jewelry, Silk Guards, Opera, Field and Marine Glasses, Pearl Card Cases. Also a full line of Gold and Plated Jewelry. 15 Maiden Lane, N. Y.

**Wheeler, Parsons & Hays.**—Manufacturers of Fine Jewelry, Watch Cases, Gold Chains, &c. and Dealer in American and Swiss Watches, No. 2 Maiden Lane, N. Y.

**White, N. H.**—Jobber in American-Waltham Watches and Chronographs. Waltham make of 10-k., 14-k. and 18-k. Gold and Sterling Silver Cases; Filled Gold Cases. 11 Maiden Lane.

**Watch Tools, etc.**

- Keller, L. H. & Co.**—Importers of Watchmakers' and Jewelers' Tools, Materials, etc. 64 Nassau Street, N. Y.
- Zimmern, Henry**—Importer of Watch Materials, Tools, and Optical Goods, No. 8 Maiden Lane, (first floor.) Sole Agent for A. Hugenin & Gravier. Mainsprings, New York.

**PHILADELPHIA**

- Bennett, Jacob & Son,**—Diamond Setters and Manufacturing Jewelers, 925 Chestnut St.
- Bernard & Co.**—Manufacturers of Fine Roman and Etruscan Jewelry. Designs of every descrip- tion made to order, 123 & 125 South Eleventh Street, Philadelphia.
- Booz & Co.**—Makers of Fine Gold Watch Cases and Plain Gold Rings, also Dealers in all Ameri- can Movements, Diamonds, Jewelry, etc. 108 South 8th Street, Philadelphia.
- Conover David F. & Co.**—American Watches, Wholesale Salesroom, Southeast corner 7th and Chestnut Streets, Philadelphia.
- Herold, Chas P.**—Successor to Hildebrandt, Her- old & Co., Manufacturing Jeweler and Diamond Setter. Diamonds. 916 Chestnut Street.
- Krieder, Peter L.**—Manufacturer of Sterling Sil- ver Ware. 618 Chestnut Street, Philadelphia.
- McCall & Newman**—Manufacturing Jewelers. Makers of the Original Gold Crown Filled Rings. No. 625 Arch St., Philadelphia.
- Morgan & Headly.**—Manufacturing Jewelers. Cameo Sets, Gold Sets, Roman Lockets, Rings, Coral Sets and a general line of rich goods. Cor- ner 10th and Chestnut Streets, Philadelphia.
- Muhr's, H. Sons,**—Manufacturing Jewelers. Solid Gold and Filled Rings a specialty. 633 and 635 Chestnut Street, Philadelphia. 1½ Maiden Lane, New York.
- Peters, Reese S.**—Manufacturer of Patent Rolled Plate or Filled Watch Cases, Dealer in American Movements, 308 Chestnut Street, Philadelphia.
- Rosenthal, G. F. C.**—Manufacturing Jeweler and Diamond Setter. Engraving and Designing of Monograms a specialty. No. 917 Sansom Street.
- Scherr, L. A. & Co.**—Wholesale Dealers in Watches Silver-Plated Ware, Spectacles, Fancy Goods, Watch Materials, etc. 726 Chestnut Street.
- Sheafer, W. H. & Co.**—Manufacturing Jewelers. Specialty: Band Bracelets. Factory, 612 and 614 Chestnut street, Philadelphia. Office, 15 John street, New York.
- Simons, Brother & Co.**—Manufacturers of Fine Jewelry, Canes, Thimbles, Chains. 611 and 613 Sansom Street.

**CHICAGO.**

- American Watch Company,**—of Waltham, Mass. No. 102 State Street, Chicago.
- Clapp & Davies**—Wholesale Jewelers, 63 and 65 Washington Street. Catalogue and price list issued to watchmakers and jewelers.
- Dennison Manufacturing Co.**—Manufacturers of Jewelers' Paper Boxes, Morocco Cases, Tags, Cards, Pink and White Cotton, Tissue Papers, Sealing Wax, &c., &c., 102 Madison St., Chicago. Boston, New York, St. Louis, and Philadelphia.
- Gilbert, Wm. L. Clock Co.**—Manufacturers of Clocks, Regulators, and Time Pieces, and Clock Material of every description, 54 and 56 Madison Street, Chicago.
- Giles, Bro. & Co.**—Manufacturers and Jobbers in Watches, all classes of Jewelry, Materials, Clocks, Silver Ware, &c. Illustrated catalogues furnished to dealers on application. 101 & 103 State St.

## NEWARK.

- Baker & Co.**—Gold, Silver and Platinum Refiners Assayers and Sweep Smelters. 408 New Jersey Railroad Avenue, cor. Murray St., Newark, N. J.
- Diefenthaler Bros. & O'Donnell**—Manufacturers of Fine Jewelry, Lace Pins, Ear Rings and Patent Spring Bangles a Specialty. 36 Crawford Street, Newark, N. J.
- English & Miller**—Manufacturers of Gold Jewelry, Diamond and Fancy Stone Rings, Roman Locketts, Bangle and Flexible Bracelets, Knife Edge Lace Pins and Sets, Scarf Pins and Link Buttons. 61 and 63 Hamilton St., Newark.
- Felger, F. & F.**—Manufacturing Jewelers. Specialties:—Roman Band Bracelets, Lace Pins, Scarf Pins, Ball and Fancy Ear Rings. No. 477 Washington Street, Newark, N. J.
- Fiedler, Herrman**—Successor to Kunze & Fiedler, Engraver, Die Sinker and Press Tool Maker, 363 Market Street, Opposite Pennsylvania R. R. Depot, Newark, N. J.
- Glorieux, W. L.**—Assayer, Refiner and Sweep Smelter. 13 and 15 Franklin Street, Newark, N. J.
- Hopper & Wilson**—Manufacturers of Fine Jewelry, No. 3 Maple Place, Rear 44 Green St., Newark, N. J.
- Hüger & Heitlinger**—Manufacturers to the Jobbing Trade only. Makers of Roman, Stone, Engraved and Enameled Locketts a specialty. Also Sleeve Buttons, Collar Buttons and Studs. 477 Washington Street, Newark, N. J.
- Krippendorf, C. & Schuller, F.**—Machinists and Jewelers' Tool Makers. 19 Greene Street, Newark, N. J. Rolls, Dies, Cutters, and Draw-plates of every Description made and repaired.
- Lelong, L. & Bro.**—Gold and Silver Refiners. Assayers and Sweep Smelters, Southwest corner of Halsey and Marshall Streets, Newark, N. J.
- Milne, Alex.**—Manufacturer of Stem-winding Watch Crowns. 19 Ward Street.
- Nesler & Co.**—Manufacturers of 18 Kt. Gold Filled Hoop Ear Rings, Plain, Facet and Engraved, all sizes. 36 Crawford St., Newark, N. J.
- Regad, E. D.**—Lapidary. Specialty—Sardonyx, Black Onyx and Agates. 14 Oliver St., Newark.

## PROVIDENCE

- Arnold & Webster**—Manufacturers of Solid Gold Engraved Band Rings for the Jobbing Trade. 29 Point Street, Providence, R. I.
- Butts, Geo. F.**—Manufacturing Jeweler. Ladies' and Misses' Solid Gold Drops and Studs a Specialty. 119 Orange Street, Providence, R. I.
- Bradley, R. & Son**—Manufacturers of Solid Gold and Rolled Plate Jewelry. White Stone Goods a Specialty. 227 Eddy Street, Providence, R. I.
- Capron & Co.**—Manufacturers of Jewelry. Engraved Box Bracelets, Bangle Wire Bracelets, Original Lever Collar and Cuff Button. No. 407 Pine Street, Providence, R. I.
- Elmwood Paper Box Co.**—Makers of Jewelers' Cases, Trays, etc. Factory, 54 Greenwich St., Providence, R. I.
- Hamilton, William & Co.**—Manufacturers of Fine Rolled Plated Chains and Patent Band Bracelets. 116 Pine St., Providence, R. I.
- Harrington, J. C.**—Maker of Fine Gold Plated Jewelry. Specialties:—Oval Wire Bangles, Band Bracelets and the Victor Swivel. 129 Eddy St., Providence, R. I.
- Hough, W. S., Jr., & Co.**—Manufacturers of the Hough, Jr., Rolled Plate Locketts, Charms and Pendants. For sale by all first-class Jobbers or Wholesale Jewelers in the United States and Canadas.
- Hutchison & Huestis**—Makers of Solid Gold Rings. Quality guaranteed. For the Jobbing Trade only. 185 Eddy Street, Providence, R. I.
- Irons, Chas. F.**—Manufacturer of Solid Gold Jewelry. Specialty. Emblems, Pins and Charms, Masonic, Odd Fellows, etc. 102 Friendship St.
- Pitts & Hicks**—Manufacturers of the Excelsior Button and Eclipse Lever Button, also a line of White Stone Gold Goods and a fine line of Lace Pins and Drops in Rolled Plate Goods. 120 Dorrance Street, Providence, R. I.
- Taylor, Geo. H. & Co.**—Watchmakers and Wholesale Dealers in Watches, Clocks, Watch and Clock Material, Tools, Spectacles, Eye Glasses, &c. Particular attention given to trade work. 136 Westminster Street (Room 1), Providence, R. I.

## PAWTUCKET.

- Fuller, Geo. H. & Son**—Jewelers' Findings, Gold, Silver, Gold Plated and Fire Gilt. Pin Stems, Joints, Catches, Split Rings, Chain Hooks and Swivels, Ear Wires, Chain Bars, etc. 99 Exchange Street, Pawtucket, R. I.

## CINCINNATI.

- Holland, John**—Manufacturer of Gold Pens, Pencils and Pencil Cases, Gold Toothpicks, etc. Nos. 19 and 21 W. 4th St., Cincinnati, Ohio.
- Lodwick & Nolting**—Wholesale Jewelers (exclusively), S. W. cor. Fourth and Walnut Streets, Cincinnati, Ohio.

## BOSTON.

- Boston Watch Case Co.**, makers of Watch Cases. Especial attention given to Repairing. 1, 3 & 5 Province Court, Boston, Mass.
- Boyce, E. J.**—Manufacturer of Solid Gold Jewelry. Rings a Specialty. 383 Washington St., Boston, Mass.
- Weber, H. & Co.**—Wholesale Jewelers, Importers and Jobbers of Fine Watch Materials, Jewelers' Findings, Tools, etc., Optical Goods and Silk Guards. Agents for Whitcomb, Standard and Stark's Lathes. 424 Washington St., Boston, Mass.

## BUFFALO.

- Klein, E. F. O.**—Jobber in Watch Materials. Watches and Chronometers repaired and adjusted for the trade; also Gold and Silver Plating. Sample Bottle of "Magic Solution," for cleaning Watches, including receipt, to any address, on receipt of \$1.50. This is a great time-saver and does the finest work. No one will do without it if used once. 346 Broadway, Buffalo, N. Y.
- Oliver, W. W.**—Manufacturer of Hand and Power Rolling Mills for Jewelers and Silversmiths, 39 Clinton Street, Buffalo, N. Y.

## CLEVELAND.

- Chandler, J. M. & Co.**—Manufacturers of the Patent Embossed Bracelet and Jobbers in all kinds of Clocks, Watches, Jewelry, Tools, Materials, etc. 185 Superior St., Cleveland, O.

## LANCASTER.

- Bowman & Musser**—Jobbers in Watches, Clocks, Chains, Fine Tools and Materials. 20 East Chestnut Street, Lancaster, Pa.

## PITTSBURGH.

- Barrett, G. B., & Co.**—Wholesale Jewelers and Diamond Importers. We carry a line of everything required by the trade. Lowest prices guaranteed. 101 Fifth Avenue, Pittsburgh, Pa.
- Goddard, Hill & Co.**—Wholesale Dealers in American Watches, Jewelry, Silverware, Clocks, Materials, &c., 43 Fifth Avenue, Pittsburgh, Pa.
- Hodge, Slemmons & Co.**—Wholesale Dealers in American and Swiss Watches, Diamonds, Gold and Plated Jewelry, Clock Material, etc. No. 77 Fifth Ave., Pittsburg.

## NEW BEDFORD.

- Nye, W. F.**—Manufacturer of Watch, Clock and Chronometer Oils, New Bedford, Mass.
- Wheeler, G. B.**—Manufacturer of Watch and Chronometer Oils, New Bedford, Mass.

## WORCESTER.

- Washburn & Moen Manufacturing Co.**—Makers of Fine Watch Mainsprings, Worcester, Mass. 16 Cliff Street, New York. 107 to 109 Lake Street, Chicago, Ill.

## WINCHESTER.

- Goodell & Winn**—Manufacturers of American Watch Hands, Winchester, Mass.

## ALBANY.

- Reiss, Chas.**—31 and 33 So. Pearl Street, Albany, N. Y. Importer of Watch Tools and Material; General Supply; Low Prices. Repairing for the Trade.

## KEOKUK, IOWA.

- Ayres, T. R. J., & Sons**—Wholesale Jewelers. Watches, Jewelry, Diamonds, Silverware, Clocks, Optical Goods, Tools, Material, &c, at lowest eastern prices. Correspondence solicited.

## CANADA.

- Ellis, P. W. & Co.**, No. 31 King street, East Toronto, Ontario, Manufacturing Jewelers, Watchmakers, importers and Jobbers of Watchmakers, and Jewelers' Tools, Materials, General Supplies and American Jewelry. Correspondence solicited with manufacturers of Novelties or specialties in American Tools and Jewelry.

GEO. W. DUBOIS.

F. N. NAUMAN.

## GEO. W. DUBOIS &amp; CO.,

IMPORTERS OF

## Watches &amp; Optical Goods.

ALL STYLES AND QUALITIES OF

SPECTACLES AND EYE-GLASSES.

## Longines' Watches and Movements,

The Watches in Gold, Silver and Nickel Cases of New and Handsome Patterns. The Movements fit 18 size Waltham Stem Winding Hunting Cases.

36 Maiden Lane, New York.

ORDERS BY MAIL RECEIVE PROMPT ATTENTION.

**BARNES'**  
**No. 4 LATHE,**  
For the Heavier Work of Jewelers.

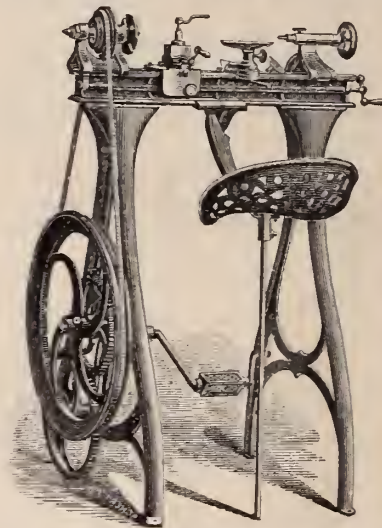

Barnes' Patent Foot and Steam Power Machinery. Complete outfits for Actual Workshop Business. Lathes for wood or metal. Circular Saws, Scroll Saws, Formers, Mortisers, Tenoners, etc., etc. Machines on trial if desired. Descriptive Catalogue and Price List Free.

**W. F. & JOHN BARNES,**  
2088 Main Street, ROCKFORD, ILL.

## American Lens Mfg. Co.,

MANUFACTURERS OF

## Optical and Object Lenses

OF ALL KINDS.

KATONAH, N. Y.

Spectacle Lenses a Specialty.

# AMERICAN WATCH TOOL CO., WALTHAM, MASS.

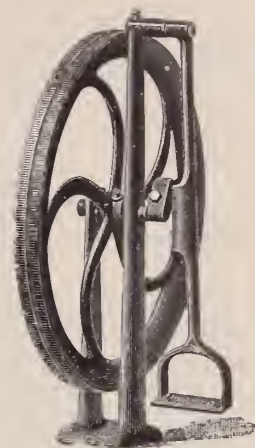
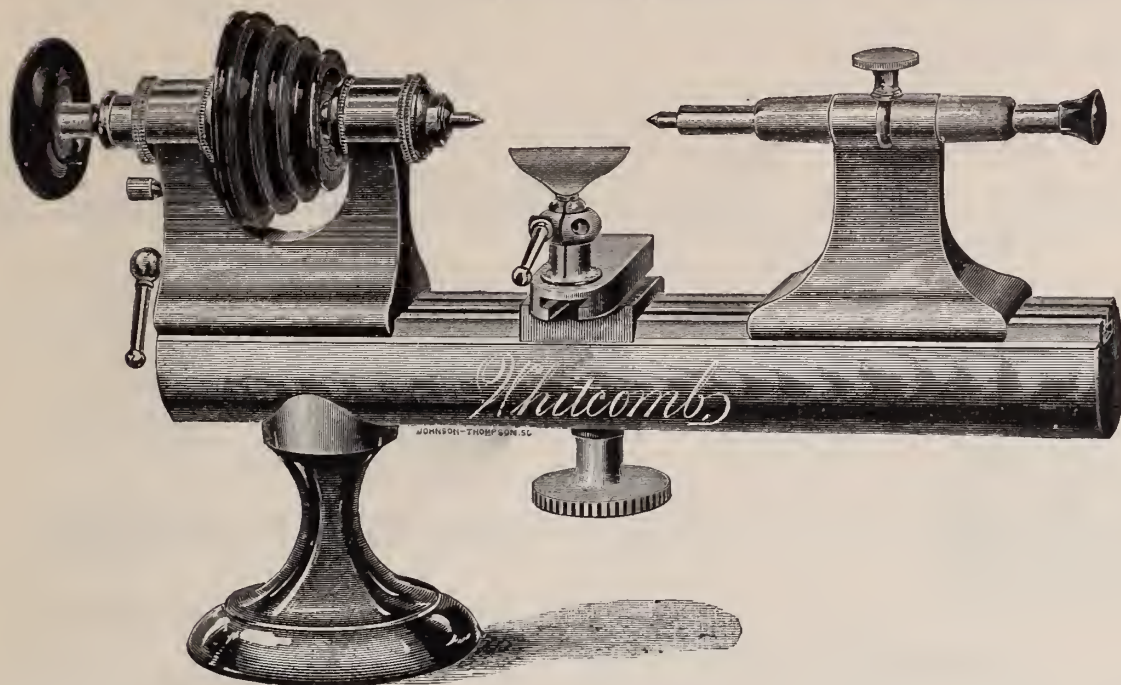

“Webster” Foot Wheel.

Combines all the Good Points  
of all others.

SEND FOR OUR CATALOGUE AND PRICE-LIST FOR 1884.

It tells you when all the Watch Companies were organized, Number of Employees, Capital, Etc., Etc.

WESTERN OFFICE, 31 WASHINGTON STREET, CHICAGO, ILLS.

## STANDARD DUST-PROOF WATCH KEYS.

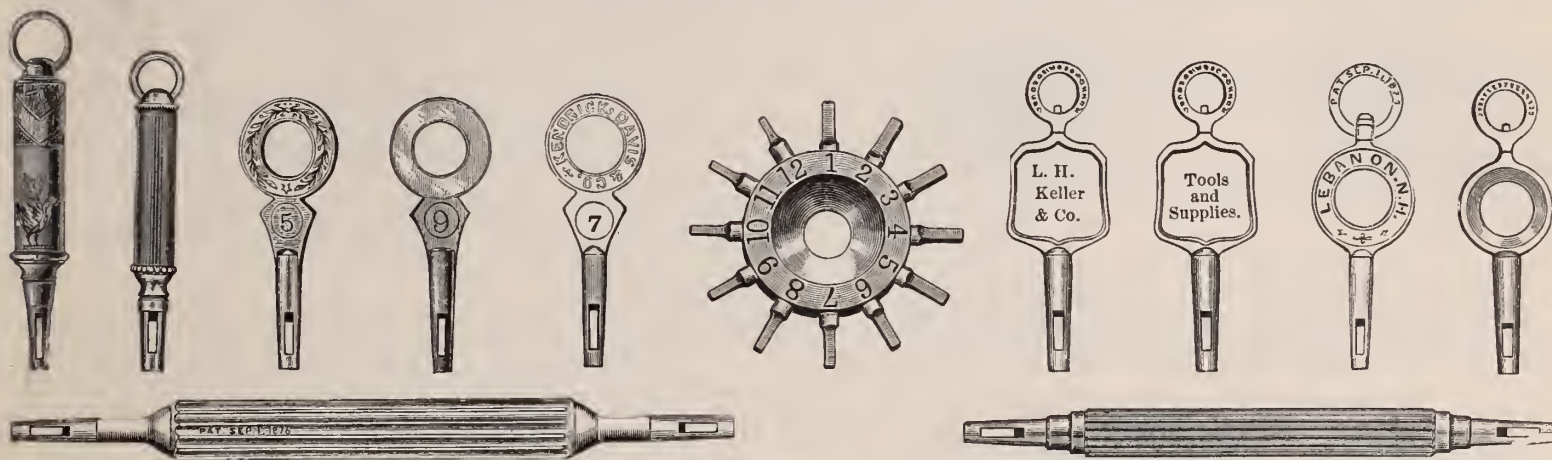

FOR SALE BY



THE TRADE.

# KENDRICK & DAVIS,

Sole Owners and Manufacturers, Lebanon, N. H.

ILLUSTRATED CATALOGUE and PRICE LIST SENT ON APPLICATION.

# Spencer Optical Manuf'g Co.

ARE MAKING MANY

**NEW AND DESIRABLE STYLES**

FOR THE

**EARLY FALL TRADE.**

**BETTER FINISH.**

**PRICES THE LOWEST.**

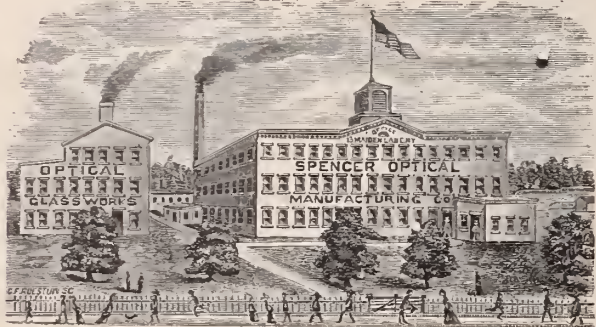

**Great Reductions in Rubber Eye-Glasses.**  
**GREAT REDUCTIONS ON PEBBLES.**

The Most Perfect Pebble Tester ever made. Works Instantaneous.  
No directions required. Price, \$1.50—half the price of  
Common Imported Testers.

Our GOLD GOODS are Unsurpassed for

**Beauty, Durability and Finish.**  
**QUALITY GUARANTEED.**

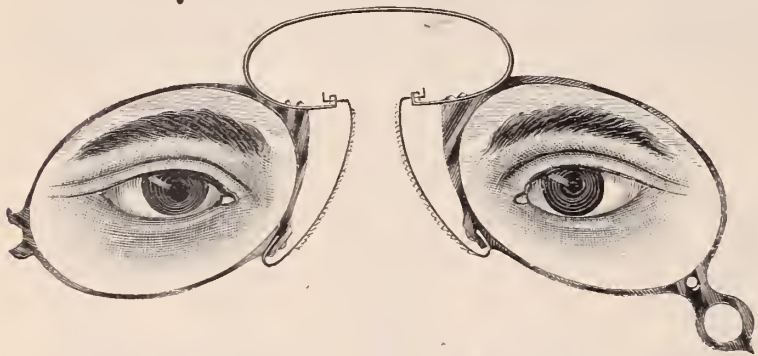

## CELLULOID SPECTACLES AND CELLULOID EYE-GLASSES

have made their own reputation and are universally popular wherever introduced.

**BEWARE OF IMITATIONS.**

If you wish a Specialty, call on us.

We make a **SPECIALTY** in **SPECIAL GOODS** for the **FINE RETAIL TRADE**, which gives customers handling our goods **IMMENSE ADVANTAGE** over all others, each dealer having a Specialty of his own, thereby destroying the ruinous competition which exists in many cities at the present day.

**QUALITY OF GOLD GUARANTEED.**

We are importing large Invoices of Opera, Field and Marine Glasses in Staple and Novel Designs.

Catalogue sent on receipt of Business Card.

**Spencer Optical Manufacturing Co.,**  
13 MAIDEN LANE, NEW YORK.

Established 1853.

# L. H. KELLER & CO.

Successors to G. A. HUGUENIN,

IMPORTERS OF

WATCHMAKERS' and JEWELERS'

**TOOLS AND MATERIALS.**

GENERAL AGENTS FOR

The Philadelphia Watch Company,

— AND —

American Watch Tool Co.,

MANUFACTURERS OF

**THE WHITCOMB LATHE.**

SOLE AGENTS IN THE UNITED STATES FOR THE SALE OF

**LUTZ'S**

**CELEBRATED ROLL HARDENED HAIR SPRINGS,**

**MOEBIUS OIL**

For Chronometers, Watches, Clocks, Telegraph Instruments and all other delicate machinery. Made from Pure Refined Neatsfoot Oil, and Warranted to Excel anything in the market as a Lubricator. **SAMPLES GRATIS.**

**OUR OWN GRADUATED**

AND JURGENSEN RECOILING MAINSPRINGS, pronounced by all experts Superior to all. Sold in Separate Strengths or Force.

Extra Fine Pinions cut from Solid Steel Wire. Gauged Hole Jewels of First-class Workmanship. A Full Line of Materials, for the PATEK, PHILIPPE & CO. GENEVA WATCHES, and all other Celebrated Makers.

**THE BOLEY LATHES AND TOOLS,**

Celebrated for their Practical, Substantial and Workmanlike Construction, Superior Design and Finish.

*Our aim is to furnish nothing but First-class Serviceable Goods, especially manufactured for the Consumer, and not solely for the Market, like the cheap trash advertised in highly illustrated catalogues with which the country is flooded.*

**TREATISE ON MODERN HOROLOGY IN THEORY AND PRACTICE.** By M. CLAUDIUS SAUNIER, Ex-Director of the School of Horology at Macon, France; Knight of the Legion of Honor, etc.; Hon. Sec. to the Paris Society of Horologists. Translated from the French by JULIEN TRIPPLIN, Besançon Watch Manufacturer, and EDWARD RIGG, M. A., Assayer in the Royal Mint, London.

This Work comprises 832 large octavo pages, with 78 wood cuts and 21 colored double-page copper-plate engravings. Bound in half calf, with an appropriate and handsome ornament in gold on front cover.

**Price, \$15.00.**

**THE WATCHMAKER'S HAND BOOK.** By the same author and translators. Intended as a companion to the Treatise. Bound in cloth.

**PRICE, \$4.00.**

**64 Nassau Street,**

NEAR MAIDEN LANE,

**NEW YORK.**

L. H. KELLER,  
EDWARD HUNZIKER,  
F. J. BOESSE.

We do not publish Price Lists.

**SPECIAL NOTICES.**

**Notices under this heading, not to exceed Six Lines, \$1.00 each insertion.**

Advertisers having letters addressed in care of this office, must inclose postage for answers forwarded.

**WANTED**—A good engraver and watchmaker. Address John Jones, care Jewelers' Circular, N. Y.

**WANTED**—For the first of December, a first-class watchmaker and jobber. Good references required. Apply to Savage & Lyman, Montreal, Canada.

**FOR SALE CHEAP**—8 silver plated frame show cases, 8 feet long, with tables and drawers complete. Inquire of Jaques & Marcus, 17th street and Broadway.

**OFFICES to LET** for wholesale jewelry business. Best location in the city, and magnificent light. Apply to Jaques & Marcus, N. W. cor. 17th street and Broadway.

**WANTED**—Situation to learn the watchmakers' trade. Age twenty (20) years. Can furnish first-class reference. Address Harry S. Banta, P. O. Box 14, Vevay, Ind.

**WANTED**—Situation by a young man as watchmaker and salesman, of best references. Have had four and a-half years' experience. Address E. S. K., care Jewelers' Circular.

**STOLEN**—A ladies' 8-size watch, Philadelphia movement, No. 4565, 14 karat gold cases, 23 dwt. Please look out for it and oblige, yours respectfully, Charles Petersen, Honesdale, Pa.

**TRAVELING SALESMAN** wants position. Young, enterprising and reliable. Excellent references. Still with old house but desires a change. Address H. W. W., care Jewelers' Circular.

**FOR SALE**—A good paying jewelry business. Good trade and run of jobbing established; a lively town. has four railroads. Stock can be reduced to \$3,000. Address Lock Box II, Cuba, N. Y.

**BOOK MARKS**—A novelty in advertising, designed and printed on silk and card, especially for the jewelry trade. Send your address for samples and prices to J. T. Little, Williamsport, Pa.

**FOR SALE CHEAP**—A Swiss Universal lathe, gear motion, slide rest, 3/4 inch plate, in good condition, with box complete. Price an object. Address Lathe, or call and see it. 28 Bond Street, N. Y.

**WANTED**—A situation by a young man in the jewelry business to finish the trade. Has had 2 years' experience at the bench. Best of references given. Address Frank S. McKee, 136 E. Fed. st., Youngstown, O.

**WANTED**—The addresses of all traveling dealers in watch materials, etc., to introduce an easily selling and well paying novelty. Communications will oblige H. B., care Editor Jewelers' Circular, 42 Nassau St., N. Y.

**WANTED**—Situation to finish my trade. Have had two years' experience in cleaning and repairing watches, clocks and jewelry. Satisfactory reference given. Address G. W. E., No. 113 Federal St., Allegheny, Pa.

**S. MILLARD**—Manufacturer of stem winding wheels. English, Swiss and American watches altered from key to stem winding. Watch wheels of all kinds made to order. No. 6 John street, N. Y.

**MOSELEY & CO.**, Elgin, Ill., manufacturers of the "Moseley" Lathe, with full line of fixtures and attachments. Designed especially for the watchmaker and repairer. Combining accuracy, durability, convenience and style.

**WANTED**—Position in wholesale house by young man of 21 years past, as traveling salesman or work in the house. Can give good references from my present employer. Have worked in retail store about 4 years. Address Charles, care Jewelers' Circular.

**WATCHMAKERS TAKE NOTICE**—Do not fail to send your address and get full particulars of my valuable discovery. Every watchmaker that has tried it is well satisfied. It saves time, money and labor. Address J. B. Dale, Box 686, Edwardsville, Madison Co. Ills.

**FOR RENT**—Desk and vault room in the Jewelers' Exchange Building, corner State and Washington streets, Chicago. Fire-proof building. Fire and burglar-proof vault. Suitable for manufacturing jewelers or importers office. Logue & Bard, 104 State st., Chicago.

**SITUATION WANTED** by man 30 years of age who thoroughly understands the manufacturing of jewelry. Have also worked in store. Can do general jobbing and repairing. Can also do some engraving and monograms. Best references. J. H. W. 227 West 125th street, N. Y.

**WANTED**—Position by young man with some years' experience with N. Y. city and vicinity trade; having been selling on commission and would like a salaried position, or a salable line with other goods on commission. Still with old house. Address J. G. B., care Jewelers' Circular.

**GEORGE E. WILKINS**, manufacturer and importer of cutters for watchmakers' use, stem-winding cutters of all the different forms, rounding up cutters of the finest quality, also ratchet cutters. A large stock of second hand and new marine chronometers. No. 21 South Salina street, Syracuse, N. Y.

**FOR SALE**—First-class jewelry store in town of 8,000 population and thickly settled country around. Leading store of the place in stock and trade. Will invoice stock and fixtures about \$5,000. Reasons for selling are not a practical jeweler and want to move west. Address C. C., care Jewelers' Circular.

**FOR SALE**—A small good paying jewelry store on Market street, Newark, N. J. Stock and fixtures worth \$1,500. Weekly sales, \$75 to \$100; repairing about \$15. Rent moderate. Cash money needed. \$500; balance can run one year. A rare chance for a good watchmaker. Address Jewelry Store, 48 Market street, Newark, N. J.

**STOLEN**—One 18 size Boss patent filled case 37,144 movement Elgin stem wind No 870407. B. J. Parver, Selma, Ala., engraved in case. One open face gold key wind, No. 56,847, Vacheron & Constantin. Enamelled in colors. A liberal reward will be paid for the recovery of the above. Address R. H. Mabry, Selma, Ala.

**TUBING** of every description drawn to order at short notice. Gold pen, pen and pencil cases, novelties, tooth picks, at lower prices than can be purchased elsewhere. Sample line sent on approval to approved parties. Gold pens re-pointed, repaired, exchanged. Ray Manufacturing Company, salesroom and factories, 94 & 96 Nassau St. and 129, 131 and 133 Fulton St., New York.

**FOR SALE**—The stock, fixtures, good will and lease of a well established jewelry store on a prominent retail street and opposite one of the best markets. Repairs average from \$25 to \$30 per week. Stock amounts to about \$1,500 but can be reduced to suit purchaser. A splendid chance for a good workman. Satisfactory reasons for selling given. For particulars address Henry L. Lemkuhl, 302 North Howard street, Baltimore, Md.

**A PAYING JEWELRY STORE FOR SALE** in Danville, Pa. The only store carrying stock in the town. Population 9,000. Large iron works supporting the town and in the heart of an agricultural district. No old stock, all clean and well selected. Work for two repairers. Best opening for anyone in the state. Established since 1870. Terms and reasons for selling made known to purchaser. Address Sparr's Jewelry Store, Danville, Pa.

**TO THE TRADE**—I make a specialty of supplying the Trade with stones for jobbing purposes. Parties having jewelry out of which the stones have been lost, sending their orders by mail or express, will have them promptly attended to. A large stock of cameos, pearls, turquoise, garnets, amethysts, doublets, foil backs, white and colored imitation stones on hand. All kinds of setting done for the Trade. W. Archibald, 73 Nassau street, New York.

**FOR SALE**—Stock and fixtures of leading jewelry store at South Bend, Ind. Will reduce stock to nearly any amount desired and give possession Dec. 1st, in time for the holiday trade. Have occupied store for ten years; business during that time has averaged \$1,000 monthly; labor about \$100 per month. Best advertised store in Co. and none in the land has a better reputation for honorable dealing. Refer to Mess. C. G. Alford & Co. and Mess. Marx & Weis of New York. Hight & Fairfield, South Bend, Ind.

**FOR SALE**—Jewelry stock, fixtures, &c., in city of Fort Worth, Texas, the best town in the state. Stock consists of watches, clocks, jewelry, silverware, &c. Goods new and fresh, all bought inside last 60 days at lowest cash prices. Good location as in city, and lease until Sept. 1st. Will sell entire stock and fixtures (with or without tools and material) at sacrifice for cash, or take part trade in good property at its cash value. Satisfactory reasons for selling. A big bargain to purchaser and most salable stock in Fort Worth. Finest fixtures in the state. Address R., P. O. Box 83, Fort Worth, Texas.

**FOR SALE**—A good paying jewelry business in a good live city in middle Nebraska. 3,500 inhabitants, 4 good railroads, county seat, and surrounded by a good farming country. Present stock about \$10,000, can be reduced to suit purchaser. A good run of work, enough for 2 men; good prices for everything, competition light, rent low, and the best location in the city; good, nice and clean stock, all staple. There was never a chance better than this for a man who wants to make money in the jewelry business. It will double discount any big city business with the same capital invested. Good reason given for selling out. For other information write to The Leading Jeweler, P. O. Box 99, Columbus, Nebraska. A man who has not got \$4,000 to \$5,000 need not reply.

**BUYERS' DIRECTORY.****NEW YORK.**

**Assayers and Sweep Smelters.**  
**Wundoehl, H.**—Gold and Silver Refiner, Assayer and Sweep Smelter. 21 John Street, N. Y.

**Badges and Medals.**

**Frick, John & Co.**—Makers of Medals and Badges of all kinds. Also Manufacturers of Jewelry. Dealers in Fine Rolled Plated Goods, etc. 23 Maiden Lane, N. Y.

**Stockwell & Newman**—19 John Street. Manufacturers of Badges, Medals and Presentation Pieces in Gold and Silver. Also Jewelry and Mounters of Diamonds. Designs supplied.

**Band Rings.**

**Knapp, Charles**, 41 Maiden Lane, N. Y. Specialty: Superior Band Rings, also Ring Shanks & Heads for Seal and Diamond Rings.

**Black Onyx Jewelry.**

**Cox & Sedgwick**—Manufacturers of Black Onyx Jewelry, No. 26 John St. New York.

**Lawson, Samuel**—No. 18 John Street. Manufacturer of Black Onyx Jewelry. Coral repaired for the trade. Goods sent on approval to responsible dealers.

**Woglom & Miller**—Manufacturers of (exclusively) Black Onyx Jewelry, 32 & 34 John St., N. Y.

**Blue Enameled Lockets.**

**Bissinger, Philip & Co.**—Importers of Diamonds, Pearls and Precious Stones. Agent for the Bohemian Garnet Goods. Blue Enameled Lockets. 22 John St., N. Y.

**Emrich, I.**—Importer of Blue Enameled Lockets, Ear Drops and all kinds of Enameled Jewelry; also Enamel for Manufacturing purposes. 66 Nassau St., N. Y.

**Bohemian Garnet Jewelry.**

**Bissinger, Philip & Co.**—Importers of Diamonds, Pearls and Precious Stones. Sole Agent for the Bohemian Garnet Jewelry. Blue Enameled Lockets. 22 John St.

**Emrich, I.**—Importer of Half Pearls and Bohemian Garnet Jewelry. Designs made to order in our European Factory at moderate prices. 66 Nassau St., N. Y.

**Clock Companies.**

**Ansonia Clock Co.**—Manufacturers of every description of Clocks. 11 to 21 Cliff street, New York.

**E. Howard Watch and Clock Co.**—No. 29 Maiden Lane, New York, and 114 Tremont St., Boston.

**Kroeber, F.**—Manufacturer and Dealer in American and French Clocks, No. 14 Cortlandt Street.

**Le Boutillier & Co.**—Importers and Jobbers in French Marble Clocks. 31 and 33 West 23d Street, N. Y.

**New Haven Clock Co.**—16 and 18 Park Place, N. Y.

**Seth Thomas Clock Co.**—20 Murray Street, N. Y.

**Waterbury Clock Co.**—Manufacturers, No. 10 Courtlandt St., N. Y. and No. 63 Washington St., Chicago, Ills.

**Welch, E. N., Manufacturing Co.**—Manufacturers of American Clocks. No. 6 Warren St.

**Wm. L. Gilbert Clock Co.**—No. 6 Murray Street, Manufacturers of Clocks. Factories, Winsted, Conn.

**Cameo Cutters, Etc.**

**Peiter, Theodore**—Cameo and Intaglio Engraver. Patentee of the Cameo-Intaglio. No. 3 Maiden Lane, New York.

**Charms & Gold Watch Keys.**

**Rupp & Held**—Manufacturing Jewelers, Charms and Gold Watch Keys, with French and English Ratchets, a specialty. 15 John St., N. Y.

**Chasers and Engravers.**

**Deming & Lincoln**—Chasers and Engravers. Fine Engraving of Plated Ware a Specialty. Chasing in all its branches. Moulds made for the trade. 73 Nassau Street, N. Y.

**Crucibles.**

**Berge, J. & H.**—Established 1850. Importers of Sand Crucibles, Covers, Chemical Porcelain, Glassware, and Jewelers' and Assayers' Supplies. 95 John Street, N. Y.

**Cutlery.**

**Harrison Bros. & Howson**—Manufacturers of Fine Ivory and Pearl Table and Pocket Cutlery, Carvers in Cases; Nutpicks, Nutcracks and goods suitable for the jewelry trade. 126 Chambers Street. W. C. Burkinshaw, Sole Agent.

**Diamond Brokers.**

**Anderson, Otis**—Diamond Merchant and Broker, always ready to pay cash for bargains in Diamonds and Precious Stones, 4 & 6 John Street, N. Y.

**Friend S. & Son**—Brokers and dealers in Diamonds 33 John Street, cor. Nassau St. New York.

**Herbert, R. J.**—Diamond Broker and Dealer. 26 Maiden Lane.

**Diamond Importers.**

- Anrich, E. L.**—Diamonds, 182 and 184 Broadway, cor. John St., N. Y. Cutting Establishment, 133 Water St.
- Bernhard, A. & Co.**—Importers of Diamonds and Manufacturers of First-class Diamond Jewelry, Diamond Settings for Manufacturing Jewelers. Catalogue of Designs for the Trade free of charge. No. 2 Maiden Lane, New York.
- Bissinger, Philip & Co.**—Importers of Diamonds, Pearls and Precious Stones. Agent for the Bohemian Garnet Goods. Blue Enamelled Lockets. No. 22 John St., N. Y.
- Bruhl, D. & M.**—Established in 1848. 14 Maiden Lane, N. Y.; 111 Broad Street, Providence, R. I.; 14 Rue Bleue, Paris.
- Brunswick, S. & Co.**—Importers of Diamonds. 17 Maiden Lane, New York. Paris, Rue Lafayette. Amsterdam, Damsiraat.
- Citroen, L. B., & Co.**—Diamonds. 21 John St., N. Y. Cutting Works, 57 & 61 Rapenburgerstraat, Amsterdam. House in Paris, 53 Rue de Chateaudun.
- Faulkenau, Oppenheimer & Co.**—Manufacturers. Diamonds and Diamond Jewelry. 40 Maiden Lane, N. Y.
- Fera, Henry**—Importer of Diamonds, and Manufacturer of Fine Diamond Jewelry. 4 & 6 John Street, New York. Amsterdam, Holland, 23 Loojersgracht.
- Fox, M. & Co.**—Importers of Diamonds, Rubies, Sapphires and Fancy Gems. No. 1 Maiden Lane, New York
- Hedges, Wm. S. & Co.**—Importers of Diamonds. No. 170 Broadway, corner Maiden Lane.
- Henle Brothers**—Importers of and Wholesale Dealers in Diamonds only. No. 16 Maiden Lane, N. Y. Paris, 20 Rue Laffitte.
- Hessels, Anthony**—Importer and Dealer in all kinds of Precious Stones. Diamond Cutters and Polishers. 45 John Street, N. Y.
- Kuhn, Doerflinger, & Co.**—Manufacturing Jewelers and Importers of Diamonds, 18 John street, New York
- Leberthon, L. M.**—Importer of Diamonds and Manufacturer of Fine Jewelry. 14 John Street, N. Y.
- Miller Bros.**—Importers of Diamonds and Manufacturers of Fine Diamond Jewelry and Mountings.
- Mulford & Bonnet**—Diamond Importers, No. 21 Maiden Lane, N. Y. City.
- Neresheimer, E. Aug. & Co.**—Importer of Diamonds. No. 21 Maiden Lane, New York.
- Randel, Baremore & Billings**—Importers of Diamonds, corner Maiden Lane and Nassau St.
- Saril, S.**—Importer of Diamonds, 182 Broadway, N. Y. Branch of Vve. H. A. Marchand & Frères, 47 Rue Le Peletier, Paris.
- Saunders & Ives.**—Importers of Diamonds and other Precious Stones. No. 26 Maiden Lane.
- Smith, Alfred H. & Co.**—Importers of Diamonds, No. 182 Broadway.
- Strauss, Jacob**—Importer of Diamonds and Dealer in Diamond Jewelry. 25 John Street.
- Tannenbaum, L. & Co.**—Importers of Diamonds and Precious Stones. Steam Lapidary Works. Oriental Stones Cut and Polished a specialty. 65 Nassau St., N. Y.
- Taylor & Brother.**—Importers of Diamonds and Diamond Jewelry. 860 Broadway.
- Wickham, D. H. & Co.**—Importer of Diamonds, No. 31 Holborn Viaduct, London, 24 Maiden Lane, New York.
- Wolff, G. A.**—Importer of Diamonds, Rubies, Sapphires, Pearls, and other Precious Stones, 65 Maiden Lane, New York. 12 Rue de Chateaudun, Paris.

**Diamond Jewelry.**

- Baldwin, Sexton & Peterson**—Importers of Diamonds and Manufacturers of Diamond Jewelry, 692 and 694 Broadway, N. Y.
- Bornemann, Louis.**—Importer of Diamonds and Manufacturer of Rich Diamond Jewelry, 19 John Street, New York.
- Chalumeau, D.**—Diamond Jeweler and Manufacturer of Mountings. Novelties and Artistic Jewelry. No. 3 Maiden Lane, New York.
- Goldsmith, Logomar & Co.**—Manufacturers of Diamond Mountings and Diamond Jewelry, 61 Nassau Street, New York.

- Goldsmith & Co.**—Manufacturers of Fine Diamond Mountings and Diamond Jewelry. Lace Pins, Ear Rings and Rings a specialty. 49 Maiden Lane, N. Y.
- Hartje, G. & F.**—Manufacturers of Diamond and Fine Jewelry, 39 Union Square, N. Y.
- Haug, John**—Manufacturer of Fine Diamond Mountings, etc. No. 130 Fulton St., N. Y.
- Heller & Bardel.**—Manufacturers of Diamond and Pearl Jewelry, and Dealers in Diamonds, Pearls, &c. 13 John Street.
- Jeanne Brothers.**—Manufacturers of Diamond Mountings & Rich Jewelry. 1 Maiden Lane.
- Lacroix & Verpillier.**—Manufacturers of Fine Gold Jewelry. Diamonds a specialty. 173 Broadway, N. Y.
- Luthy, A. & Co.**—Manufacturers of Fine Diamond Mountings, Lace Pins, Ear Rings, Rings, Knife Edge Bracelets, Hair Ornaments, etc., a Specialty. 35 Ann Street, corner Nassau Street, N. Y.
- Mitchell, Noah**—Manufacturer of Diamond Jewelry and Diamond Mountings. 52 Maiden Lane, New York.
- Nissen, Ludwig & Co.**—Dealers in Diamonds and Manufacturers of Diamond Mountings. No. 51 Nassau Street, New York, near Maiden Lane.
- Rosswog, C. & Son**—Manufacturers of Rich Diamond Goods. Nos. 5 and 7 Maiden Lane, N. Y.
- Stern & Karutz**—Manufacturers of Fine Diamond Mountings. Lace Pins, Ear Rings, Rings, Knife Edge Bracelets a Specialty. Orders by mail promptly attended to. 130 Fulton Street, Room 11, first floor, New York.
- Voelker, C. T.**—Manufacturer of 18-k. Diamond Mountings, Diamond Jewelry and Roller Chain Bracelets. 15 Maiden Lane, New York.
- Waterman & Lehmann.**—Manufacturing Jewelers and Dealers in Diamonds. Diamond Work, and Fine fancy Rings a specialty, any piece of single work made to order. 37 Maiden Lane, N. Y.
- Wienhold, J.**—Manufacturer of Fine Jewelry. Diamond Mountings a specialty. 24 John Street.

**Diamond Cutters.**

- Levy, Herman.**—Importer, Cutter and Polisher of Diamonds. 105 Fulton Street, New York.
- Mendes, D. De S.**—Diamond Cutter and Polisher, 113 Nassau St., N. Y. Re-cutting, Repairing and Matching a Specialty.
- Ramsgate, Robert H.**—Diamond Cutter and Polisher; Matching and Repairing a specialty. 16 Maiden Lane, New York.

**Dials, &c.**

- New York Dial Co.**—Manufacturers of Fine Watch Dials. Henry Abbott, Agent, No. 4 Maiden Lane, N. Y.

**Enameled Clock Dials and Figures.**

- Caeser Bros.**—Manufacturers of Enameled Clock Dials, also letters and numbers for signs. 230 and 232 East 25th Street, New York.

**Enamelers, Etc.**

- Nutt, J. D.**—Enameler on Gold, Silver, and Copper. Linen finished Buttons and Studs. Enameling in colors. 32 and 34 John Street, New York.
- Orr, J. C.**—Enameler on Fine Jewelry. Enameled in Colors. Linen Finished Buttons and Studs. Band Bracelets. No. 75 Nassau Street, N. Y.

**Engravers—Stone Seal, Etc.**

- Fackner, Edward**—Carver, Engraver and Chaser on Jewelry and Pencil Cases, lettering, &c., 19 John Street.
- Holland & Gosling**—Stone Seal Engravers. Precious Stones inlaid and encrusted with Diamonds. No. 176 Broadway, New York, (fifth floor per elevator). Cameos cut and repaired.
- Knapp, Chas.** Engraver, Die Sinker & Stamper for Jewelry purposes. Ring Shanks & superior Band rings, 41 Maiden Lane, N. Y.
- Park, Wm.**—The Stone Seal Engraver. Arms, Crests, Monograms, etc., engraved on precious stones, 26 John Street, New York.
- Weston, James F.**—Stone Seal Engraver and in-cruiter of Precious Stones. Coats of Arms, Masonic, Odd Fellows, and other devices engraved. 32 John Street,

**Fancy Goods, Clocks, Bronzes, Etc.**

- Hinrichs, C. F. A.**—Importer of Fancy Goods, Glassware, China, Clocks, Bronzes, etc. 31 Park Place.
- Le Boutillier & Co.**—Importers of Fancy Goods, Clocks, Bronzes, &c., 33 West 23d Street.
- Straus, L. & Sons**—Importers of Potteries, Faïences, Bisque Figures, and Rich Fancy Goods especially adapted for the Jewelry Trade. 40, 42 and 44 Warren Street, New York.
- Taylor & Bro.**—Importers of French Clocks, Bronzes, etc. 676 Broadway, N. Y.
- Young, J. M. & Co.**—Importers of Fine Parian, Lava, and Bisque Statuary, Bohemian, German and English Fancy Goods, 37 & 39 Murray St., New York.

**Gold and Silver Cane Heads.**

- Cuppia, L. A.**—Importer of Filigree Jewelry and Manufacturer of Silver and Gold Cane Heads and Novelties in Silver and Gold Jewelry. 19 Union Square, N. Y.
- Locklin, F. P. & Bro.**—Manufacturers of Gold and Silver Headed Canes. 142 Fulton Street, N. Y.
- Simons, Bro. & Co.**—Manufacturers of Gold Headed Canes. 611 and 613 Sansom street, Philadelphia.
- Smith, Rest Fenner & Co.**—No. 701 Broadway, Makers of Fine Gold and Silver Headed Canes.

**Gold and Silver Plating, Etc.**

- Bantle, A.**—Gold, Silver and Electro-Plating, 130 Fulton and 89 Nassau Streets, cor. Fulton Street, (Room 36,) N. Y. Watch Case Polishing.
- Jeandheur, F.**—Gold and Silver Electro Plater and Fire Gilder. Coloring Etruscan and Gold Jewelry a Specialty. 125 Fulton Street.
- Klees & Magrath**—Gold and Silver Electro-Platers. Coloring Etruscan and Gold Jewelry a Specialty. 89 Nassau Street, New York.

**Gold Chains, Etc.**

- Beck, J. & Son,** Manufacturers of Fine Gold Chains and Chain Bracelets, 10 Liberty Place, near Maiden Lane, N. Y.
- Carter, Sloan & Co.**—Manufacturers of Fine Gold Chain, 15 Maiden Lane, New York.
- Edge, W. C. & Co.**—Manufacturers of the Celebrated Woven Fabric Gold Chain, No. 15 John Street.
- Kaufmann Bros.**—Manufacturers of Gold Chains, and Chain Bracelets, 12 First Street; Factory, 331 and 333 Bowery, N. Y.
- Kohn, Alois & Co.**—Manufacturers of Gold Chains. 9 Maiden Lane, N. Y.
- Saxton, Smith & Co.**—Manufacturers of Fine Gold Chain, No. 14 John Street, N. Y.
- Schlag, Chas.**—(Late Nordt & Schlag), Manufacturer of Gold Chains, Chain Bracelets and Fine Jewelry. 177 Broadway, New York. All kinds of Jobbing promptly attended to.
- Smith, W. & Co.**—Manufacturers of Gold and Silver Chains, Jewelry, etc. No. 25 Maiden Lane, N. Y.

**Gold Pens, Etc.**

- Aikin, Lambert & Co.**—Manufacturers of Choice Gold Pens, Cases, Holders, Toothpicks, etc., 23 Maiden Lane, N. Y.
- Faber, Eberhard.**—Manufacturer of 16-karat Gold Pens and Pencil Cases. Nos. 718 and 720 Broadway, N. Y.
- Fairchild, Leroy C. & Co.**—No. 10 Maiden Lane, New York. Manufacturers of Gold Pens, Pencils, etc.
- Fairchild, Leroy W.**—Manufacturer of Gold Pens, Pencil Cases, Tooth Picks and Novelties in Charms. No. 18 John St., N. Y.
- Foley, John**—Manufacturer of Fine Gold Pens, Pencils and Charms. 2 Astor House, N. Y.
- Hicks, W. S.**—Established 1848. Manufacturer of Fine Gold Pens, Pencil Cases, Tooth Picks, and Charm Novelties of every description. No. 20 Maiden Lane.
- Johnson, E. S. & Co.**—Manufacturers of Gold Pens, Pen Holders and Pencils. Cor. Maiden Lane and Nassau Street, New York.
- Smith, H. M. & Co.**—Manufacturers of Gold Pens and Holders, Tooth Picks, Pencils, etc. Sole Manufacturers of Sprague's Patent Gold Fountain Pen. Importers of Nickel and Silver Watches. 173 Broadway, New York.

**Gold Rings.**

- Barnet Bros.**—Manufacturers of Stone and Seal Rings, 15 John Street, New York. Factory, Newark, N. J.
- Bowden, J. B. & Co.**—Manufacturing Jeweler.—Solid Gold Rings a specialty, 1 Maiden Lane.
- Cable, Geo. W.**—Manufacturing Jeweler. Plain and Band Rings a Specialty. No. 52 Maiden Lane, N. Y.
- Dattelbaum & Friedman**—Manufacturers of Fine Cameo and Seal Rings, all kinds of Fancy Rings and Diamond Mountings. 10 Maiden Lane.
- Ely, W. H.**—Manufacturer of Solid Gold Rings of every description. No. 58 Nassau Street.
- Engelfried, Braun & Weidmann**—Manufacturing Jewelers, 128 Fulton Street corner Nassau, New York. Commercial Building, room 31. Rings a specialty.
- Henrich, R.**—No. 35 Maiden Lane, Manufacturer of Gold Rings; also Patentee and Manufacturer of the Celebrated Self-Sizing Ring
- Hutchison & Huestis**—Makers of Solid Gold Rings. Quality guaranteed. For the Jobbing Trade only. 196 Broadway, N. Y.
- Kroll, H.**—Manufacturing Jeweler. 78 Nassau Street, New York. Specialty: Solid Gold Stone Rings. All kinds of Fine Jewelry made to order, also Repairing for the Trade.
- Müller, H.**—111 Nassau St., N. Y., Manufacturer of Fancy and Seal Rings of every description. Plain Gold and Chased Band Rings in 10, 14 & 18 Kt.
- Ostby & Barton**—Manufacturers of Plain and Engraved Solid Gold Band Rings. Office, 176 Broadway, N. Y. Factory, 80 Clifford Street, Providence, R. I.
- Peckham, Wm. H.**—Manufacturers of Solid Gold Seamless Rings, and Fancy Embossed Rings, Patent Spectacles, Jewelry, etc. No. 4 Liberty Place N. Y.
- Radler, K.**—Manufacturing Jeweler. Gold Rings and Locketts a specialty. No. 179 Broadway, New York.
- Sauter, L.**—No. 1 Maiden Lane, New York, Manufacturer of Stone Rings of every description, as Diamond, Cameo, Onyx Turquoise, etc., Scarf Pins, Scarf Rings, Studs and Buttons.
- Shafer & Douglass.**—Manufacturers of all kinds of Seal, Stone, Turquoise, and fancy rings. No. 7 Maiden Lane, N. Y.
- Thurner & Church**—Manufacturers of Fine Gold Rings. No. 9 Maiden Lane, N. Y.

**Hair Jewelry.**

- Moutoux, Wm. E. & Co.**—Manufacturers of Fine Hair Mountings in Gold. Grand catalogues for the trade. 81 Nassau St., Rooms 1 and 2. Finest work and lowest prices
- Sauter, L.**—Manufacturer of Fine Gold and Hair Jewelry and Device Work. Pattern Book sent on application. No. 1 Maiden Lane, N. Y.
- Schwencke O.**—Manufacturer of Fine Hair Jewelry Orders from the country promptly attended to. No. 43 Maiden Lane.

**Jewelry Cases, Fancy Boxes, Etc.**

- American Morocco Case Co.**—7 & 9 Bond St., N. Y., make a specialty of Rich Jewelry, Silverware Cases and Improved Trays for Watches, Rings, &c. Patent Watch Blocks to fit all sizes.
- Braun, Chr. E.**—Manufacturer of Fine Jewelry Boxes and Trays for Show Cases and Trunks. No. 62 Chatham Street, New York. Trays for Show Cases and Trunks a Specialty.
- Bricka & Warmers**—Manufacturers of Morocco Cases for Cutlery, Silverware, Jewelry, etc. Sample Cards and Rolls. Cases in Rosewood, Black Walnut, etc. 52 Nassau Street, New York.
- Dennison Mfg Co.**—Manufacturers of Morocco, Plush and Velvet Jewelry and Silverware cases. New York, Boston, Philadelphia, Chicago, Cincinnati and St. Louis.
- Haensler, Chas. C.**—Manufacturer of Fine Morocco Cases for Jewelry and Silverware. Toilet Boxes, etc. Trays for Show Cases and Windows. 14 John Street, New York.
- Hebbard & Brother**—Manufacturers of Jewelry and Silver Ware Cases, and Fancy Wood Chests for Tea Sets and Flat Ware. 860 Broadway, New York.
- Kohn, Solomon**—Manufacturer of Fine Morocco Cases for Jewelry, Watches, etc. 43 Maiden Lane, New York.

- Lauten, Edw. A. & Co.**—No. 4 Great Jones St., Manufacturers of Fine Velvet, Brocade, Plush and Morocco Boxes, Patent Ring, Ear Ring and Gent's Scarf Pin Trays, Patent Watch and Bracelet Blocks, Window Decorations, etc.
- Loehr & Koerner**—Manufacturers of Morocco, Velvet, Satin, Jewelry, Watches and Silverware Cases, Jewel, Work Boxes, etc., Fancy Trays and Store Fittings to order. 96 Liberty St.
- New York Morocco Case Co.**—Cases for Jewelry, Watches, Silverware. Boxes and Trays for Jewelers' Travelers. Show Cases and Window Fittings. No. 69 Nassau Street, New York.
- Schwarz, N.**—Manufacturer of fine Cases for Jewelry and Silverware. 866 Broadway, New York.
- Welch & Miller**—169 Broadway. Manufacturers of fine Morocco, Velvet, Russia, Brocade and Plush Jewelry Cases. Trays of every description; Jeweler's Cotton and Twine.
- Wiggers & Froelick**—No. 60 Nassau street—Manufacturers of Cases for Jewelry, &c., of every description. Trays for Show-cases, Stands for Show-windows, etc.

**Jewelers' Findings.**

- Dennison Mfg Co.**—Paper Jewelry Boxes, cards, tags, pink and white cotton, etc. etc. New York, Boston, Chicago, Cincinnati, Philadelphia, St. Louis.
- Ettlinger, L., & Sons**—Makers of Cases and Paper Boxes of every description for Jewelers and Silversmiths. Fine Cases and Trays to order a specialty; also Cards, Tags, Cotton, Tissue Paper, &c. 80 Nassau St., N. Y.
- Lehmann, Ludwig.**—Manufacturer of Jewelers' Findings. 122 Fulton St., near Nassau, N. Y.
- Valfer, S. & Co.**—Manufacturers and Dealers in Jewelers' Boxes, Tags, Cards, Paper and Findings. Trays a specialty. Fancy Ornaments for Show Windows. 66 Nassau street, New York.

**Jewelry Manufacturers.**

- Aikin, Lambert & Co.**—Manufacturers General stock of Reliable Jewelry, 23 Maiden Lane.
- Alling, Isaac A. & Co.**—Manufacturers of Fine Gold Jewelry. Specialties: Wire Bracelets, Bangles, American Lever Sleeve Buttons. Bryant Building, Nassau and Liberty Streets, N. Y. Factory, Newark, N. J.
- Baldwin, Sexton & Peterson**—Manufacturers of Rich Jewelry, 692 and 694 Broadway, N. Y.
- Ball, W. H. & Co.**—Manufacturers of Gold Jewelry. Bracelets and Bangles of all kinds a specialty. 9 John Street, N. Y.
- Barthman, Straat & Co.**—Manufacturers of Fine Jewelry. Roman Goods, Rings, Diamonds. No. 43 Maiden Lane.
- Bissinger, Philip & Co.**—Importers of Diamonds, Pearls and Precious Stones. Sole Agents for the Bohemian Garnet Jewelry, Blue Enameled Locketts. 22 John St., N. Y.
- Bonner & Abramovitz**—Manufacturers of Diamond Jewelry. Specialty, Ring Mountings. 128 Fulton Street, Room 30, New York.
- Brown, Thos. G. & Sons**—Man'rs of Rich Jewelry Necklaces, Locketts, Bracelets, Sleeve Buttons, etc., 860 Broadway, N. Y.
- Bryant & Bentley**—Manufacturing Jewelers. Rings a specialty. 12 Maiden Lane
- Carter, Sloan & Co.**—Manufacturing Jewelers, 15 Maiden Lane, New York.
- Champerois & Co.**—No. 5 Maiden Lane, manufacturers of Engraved and Enameled Gold goods, in Sets, Ear Knobs, Bracelets, Studs, Lace and Shawl Pins, Jet cluster and Onyx goods, also "Best Lever" Sleeve Buttons.
- Chatellier, Joseph F.**—Manufacturing Jeweler, No. 604 Broadway, N. Y.
- Churchill, Lewis & Co.**—Manufacturers of Fine Jewelry. 692 Broadway, cor. Fourth St., N. Y.
- Cook, George W.**—Manufacturer of Fine Jewelry and Locketts, 191 Broadway (over Mercantile Bank,) N. Y.
- Cottle S. Co.**—Manufacturers of Fine Jewelry. 860 Broadway, N. Y.
- Cox & Sedgwick**—Manufacturers of fine Onyx and Colored Jewelry. 26 John St., New York
- Day & Clark**—Manufacturers of Fine Jewelry, Lace Pins, Ear Rings, Studs, Locketts, &c., 10 Maiden Lane, New York.
- Geoffroy, Arthur R. & Co.**—Manufacturing Jewelers. Novelties in Diamond Goods. No. 23 Maiden Lane, N. Y.
- Greene Wm. C. & Co.**—Goldsmiths; Manufacturers of Rich Sets in Taper Wire Coral. Office, 192 Broadway.
- Griffith, H.**—Manufacturing Jeweler. Gold and Plated Jewelry. Scarf Pins a specialty. Nutty Alley, near Concord St., Brooklyn, N. Y.
- Groeschel & Resman**—Manufacturers of Fine Jewelry. No. 27 John Street, N. Y.
- Hartmann, P.**—Manufacturer & Importer of Fine Gold, Diamond, and Filigree Silver Jewelry, No. 36 Maiden Lane. P. O. Box 2,454.
- Hedges, A. J. & Co.**—Manufacturing Jewelers, 6 Maiden Lane.
- Henderson & Winter**—Jewelers, No. 15 Maiden Lane, New York. Specialties—Stone, Cameo, Onyx, Amethyst, Topaz, Pearl and Turquoise Rings.
- Hunt & Owen.**—Manufacturing Jewelers. Office 3 Maiden Lane.
- Jandorf, P. & Bro.**—Manufacturing and Wholesale Jewelers—all grades. Prompt Attention to Orders. We issue no catalogue. 196 Broadway, N. Y.
- Kipper, Vogel & Co.**—Manufacturing Jewelers, 17 Maiden Lane, New York.
- Kremetz & Co.**—Manufacturing Jewelers. No. 182 Broadway, N. Y.
- Kuhn, Doerflinger & Co.**—Manufacturers of Enameled and Roman Band Bracelets, also Fine Locketts Pendants and Lace Pins. 18 John street.
- Miller Bros.**—Manufacturers of Fine Jewelry, Diamond Goods, Sets, Lace Pins, Ear Rings, Scarf Pins, Sleeve Buttons, Studs, etc. 7 Maiden Lane, N. Y.
- Moore & Horton.**—11 Maiden Lane, Manufacturing Jewelers, Rings, Studs, Collars and Sleeve Buttons, Pins, Ear-rings, &c.
- Muhr's, H., Sons.**—Manufacturing Jewelers. Solid Gold and Filled Rings a specialty. Also Manufacturers of the celebrated Crown Filled Watch Case. 16 Maiden Lane, N. Y.
- Mulford & Bonnet**—No. 21 Maiden Lane, New York.
- Owen, G. & S. & Co.**—Manufacturing Jewelers. Office, No. 3 Maiden Lane.
- Richardson, Enos & Co.**—Manufacturers of Fine Gold Jewelry, Gold Chains, Locketts, Crosses and Necklaces. Colored and Etruscan Work. No. 23 Maiden Lane, New York.
- Richardson, J. W. & Co.**—Manufacturers of Jewelry. Masonic and other Emblems. 196 Broadway, N. Y. Manufactory, Providence, R. I.
- Riley, J. A. & Co.**—Manufacturing Jewelers. Etruscan Gold and Roman Bracelets, Lace Pins, Ear Rings, Scarf Pins, Brooch Pins, etc. No. 860 Broadway, N. Y.
- Ripley, Howland & Co.**—Manufacturers of Fine Jewelry and Platinum Tipped Diamond Settings. No. 17 Maiden Lane, N. Y.
- Schwencke, Wm.**—Manufacturing and Jobbing Jeweler. Repairing a specialty. Orders promptly attended to. No. 43 Maiden Lane, N. Y.
- Sexton & Cole**—Manufacturing Jewelers, Colored Gold and Onyx Goods a specialty. No. 30 Maiden Lane.
- Sheaffer, W. H. & Co.**—Manufacturing Jewelers, Specialty Bangles and Bracelets, 15 John St., N. Y.
- Stites' Sons, E.**—Manufacturers of Fine Jewelry. No. 14 John Street, N. Y.
- Street, Geo. O. & Sons.**—Established 1837. Makers of Fine Jewelry, strictly first-class goods of our own make. No. 15 John Street, New York.
- Thoma, Ernest**—Manufacturer of Fine Jewelry, Sleeve Buttons, Rings, Ear-rings, &c. No. 173 Broadway, N. Y. Factory, Hackensack, N. J.
- Ward, Thos. M.**—Manufacturer of Fine Jewelry, Diamond Mountings a specialty. No. 25 John Street, N. Y.
- Wienhold, J.**—Manufacturer of Fine Jewelry, Diamond Mountings a Specialty. 24 John St.
- Woglom & Miller**—Manufacturers of Black Onyx Goods exclusively. 32 & 34 John Street, N. Y.

**Jewelry—Rolled Plate.**

- Blackinton, W. & S.**—Manufacturers of the W. & S. B. Rolled Plated Chains. No. 11 Maiden Lane.
- Mauran, J. T.**—Manufacturer of Fine Rolled Plate Jewelry, No. 15 Maiden Lane, N. Y.
- Richards, E. Ira & Co.**—Manufacturers of Fine Rolled Plate Jewelry, No. 200 Broadway, N. Y.

**Jewelers' Tools, etc.**

- Fisher, James J.**—Dealer in Watchmakers' and Jewelers' Materials, Files, Tools, Silk Guards, Spectacles, etc. 695 and 697 Broadway, N. Y.
- Friedenthal, A. & Co.**—Importers and jobbers of Watchmakers' and Jewelers' Tools, Materials, etc. 43 Maiden Lane, N. Y.
- Friedlander, R. & L.**—Importers of Watchmakers' Tools and Materials. 65 & 67 Nassau Street. Branch Office, 264 Bowery.
- Koeser, C. F.**—Importer and Manufacturer of Fine Tools, Files and Polishing Materials for Jewelers, Watch Case Makers, etc. 33 John St.
- Kurtz, F. P.**—Manufacturer of Jewelers Machinery, Tools, Rolling Mills, Presses, Polishing Lathes, &c. 97 Cliff St., N. Y.
- Levy, Dreyfus & Co.**—Importers and Jobbers of Watchmakers' and Jewelers' tools and materials of every description. 11 Maiden Lane, N. Y.
- Reichhelm, E. P. & Co.**—Importers of Jewelers' Tools, Files, etc. Manufacturers of Brushes and Buffing wheels; also Patent Gas Furnaces for Melting, Plating, Enamelling, Annealing, etc. 80 Nassau St., N. Y.

**Lapidaries.**

- Fox, M. & Co.**—Practical Lapidaries, No. 1 Maiden Lane, New York.
- Graham & Co.**—Practical Lapidaries, Cutters and Polishers of all kinds of Precious Stones, Emeralds, Rubies, Sapphires, etc. Miner's Relics Cut, Polished and Mounted. Locket Glasses, 80 Nassau St., N. Y.
- Kordmann & Michel.**—Lapidaries. Dealers in Precious Stones. Cutting and Polishing Rubies, Sapphires and other Gems a specialty. Drilling done promptly. 59 Nassau St., N. Y.

**Masonic Jewelry.**

- Luther, John F.**—79 Nassau Street. Manufacturer of Fine Presentation Jewels for all Societies. Knights Templars, Crosses, Badges, &c.
- Wilkinson, C. B.**—Manufacturing Jeweler, 8 John St., N. Y. Medals, Badges and Masonic Jewelry, a specialty. Designs furnished free upon application.

**Musical Boxes.**

- Paillard, M. J. & Co.**—Manufacturers of Musical Boxes and Musical Novelties. Warerooms, 680 Broadway, N. Y.

**Optical Goods.**

- Friedlander, R. & L.**—65 and 67 Nassau Street. Dealers in Optical Goods.
- Spencer Optical Manufacturing Co.**—Manufacturers of Spectacles and Eye-Glasses. 13 Maiden Lane, N. Y.

**Opticians.**

- Burbank Manfg Co.**—Manufacturers of Spectacles and Eye Glasses of all descriptions, in gold, silver, etc., 14 Maiden Lane, N. Y.
- DuBois, Geo. W. & Co.**—Importers of Watches and Optical Goods. 36 Maiden Lane, N. Y.
- Levy, Dreyfus & Co.**—Importers of Spectacles and Eye Glasses and Optical Instruments of every description, No. 11 Maiden Lane, N. Y.
- Lorsch, Albert**—Manufacturer of the Patent Accommodating Spectacles and Eye Glasses in Gold, Silver and Steel, and other Optical Goods, 37 Maiden Lane, N. Y.
- Spencer Optical Manufacturing Co.**—Gold, Silver, Steel, Nickel and Plated Spectacles; Gold, Celluloid, Steel, Nickel and Rubber Eye Glass and Opera Glasses. 13 Maiden Lane, N. Y.
- Todd, James W.**—No. 20 Maiden Lane, N. Y. Wholesale Dealer in Optical Goods.

**Paper Boxes.**

- Lehmann, Ludwig.**—Manufacturer of Jewelers' Findings. 122 Fulton St., near Nassau, N. Y.
- Waterbury Paper and Box Co.,** 27 to 35 Canal St., Waterbury, Conn., Manufacture Jewelers' and Silversmiths' Fine Paper Boxes. Quality guaranteed to be equal to the best made.

**Polishers and Lappers.**

- Klees & Co.**—Late Abels, Polishers and Lappers of Fine Jewelry. 89 Nassau St., Room 17, N. Y.

**Precious Stones, &c.**

- Bishop, Victor & Co.**—33 Maiden Lane, Importers of Precious Stones, Cameos, &c. Also Manufacturers of Coral Jewelry.

**Bissinger, Philip & Co.**—Importer of Diamonds, Pearls and Precious Stones. Agent for the Bohemian Garnet Goods. Blue Enamelled Locket. No. 22 John St., N. Y.

**Breidenbach, R. A.**—Importer of Black Onyx, Diamonds, Pearls, Turquoise, Cameos, Sardonyx, Amethysts, Garnets, Topaz, Opals, Rubies, Sapphires, Hematite Balls, Foil Brilliants, Cat's-Eyes, Tiger Eyes, Doublets, Cabinet Specimens, etc. 85 Nassau Street, New York.

**Daue, Wm. & Co.**—Importer of Precious and Imitation Stones. No. 202 Broadway New York.

**Fox, M. & Co.**—Importers of Diamonds and other Precious Stones, No. 1 Maiden Lane, N. Y.

**Gruet, Jules.**—Importer of all Grades of Real and Imitation Stones. 14 John St., N. Y.

**Hahn & Co.**—Importers of Precious Stones, Cameos, Onyx, Pearls, Intaglios, Amethysts, Garnets, etc. 64 Nassau Street, New York.

**Kahn, L. & M. & Co.**—Importers of precious and imitation stones. 10 Maiden Lane, N. Y.

**Kipling, E. E.**—Importer of Precious and Imitation Stones. Manufacturer of the Patent Foil Solid Metal Back Rhine Stone Brilliant. No. 6 Maiden Lane, N. Y.

**Kipling, R. A.**—Precious and Imitation Stones, No. 24 Maiden Lane, N. Y. Manufacturer Cameos, Agates, Onyx, Etc., Oberstein, Germany. Commission Merchant, 49 Rue De L'Echiquier, Paris.

**Lorsch, Albert**—Importer of Precious Stones, 37 Maiden Lane, N. Y.

**Stirn, Oppenheimer & Co.**—Importers of Black Onyx, Cameos, Turquoise, Sardonyx, Garnets, Rubies and all other Precious and Imitation Stones. German, French and Vienna Novelties, 3 Maiden Lane, N. Y.

**Safes.**

**Butler, W. H.**—Fire and Burglar Proof Safes, 291 Broadway, N. Y.

**Silverware.**

**Gorham Manufacturing Co.**—Broadway and 19th Street.

**Knowles, J. P. & S. M.**—Manufacturers of Sterling Silverware, 20 Maiden Lane, N. Y. Factory, Providence, R. I.

**Shiebler, Geo. W.**—Manufacturer of Sterling Silverware. No. 8 Liberty Place, near Maiden Lane, N. Y.

**Whiting Manufacturing Co.**—Makers of Sterling Silver Ware. Broadway cor. 4th Street, N. Y.

**Wood & Hughes.**—Manufacturers of Fine Silverware. 16 John Street, N. Y.

**Silver Filigree Jewelry.**

**Cuppia, L. A.**—Manufacturer of Solid Silver Novelties, and Importer of Silver Filigree, 19 Union Square.

**Francesconi, Guido**—Importer of Silver Filigree Jewelry, 196 Broadway, New York.

**Hartmann, P.**—Manufacturer of Silver Filigree Jewelry. 36 Maiden Lane, N. Y.

**Silver Plated Ware.**

**Manhattan Silver Plate Co.**—Manufacturers of Silver Plated Ware. Showrooms, 23 John St. Factory, 301 to 305 East 22d St., cor. 2d Ave. Address all communications to Factory.

**Middletown Plate Co.**—Manufacturers of Superior Electro-Plate. Factories, Middletown, Conn., salesroom, 13 John Street.

**Rogers, Smith & Co.**—Manufacturers of Fine Electro Plated Ware. No. 46 E. 14th St., N. Y.

**Rogers & Brother**—Manufacturers of Electro-Plated Flat and Hollow Ware. 690 Broadway, N. Y.

**Schade, Henry.**—Manufacturer of White Metal and Plated Ware. Office, 26 John Street, N. Y. Price list and catalogue furnished on application.

**Simpson, Hall, Miller & Co.**—Manufacturers of fine Silver-Plated Ware. No. 36 E. 14th Street.

**The Derby Silver Co.**—Manufacturers of Finest Quadruple Silver Plated Ware. Birmingham, Conn. New York office, 25 Maiden Lane.

**Webster, E. G. & Bro.**—Manufacturers of Fine Silver-Plated Ware. Office and warerooms, 14 Maiden Lane, N. Y.

**Show Cases, Etc.**

**Smith, B. & W. B.**—Manufacturers of Patent Improved Dust Proof Show Cases, with Perpendicular Sliding Doors, No. 220 W. 29th St., N. Y.

**Spectacle Case Manufacturers.**

**Bertine, P. D.**—Manufacturer of Spectacle and Eye-Glass Cases. 139 William Street, near Fulton St., New York.

**Koenen, A. & Bro.**—Manufacturers of Leather Spectacle and Eye-Glass Cases for the Jobbing Trade only. 81 Nassau St., N. Y.

**Spencer Optical Manufacturing Co.**—Manufacturers of Spectacle and Eye-Glass Cases. 13 Maiden Lane, N. Y.

**Stem Winding Attachments.**

**Abbott, Henry** Maker of Stem Winding Attachments, No. 4 Maiden Lane, N. Y.

**Swivels and Spring Rings.**

**Schwartz, V. & Co.**—Manufacturers of Gold Swivel and Chain Trimmings. 33 Barclay Street, New York.

**Thermometers, Etc.**

**Tagliabue, Giuseppe.**—manufacturer of Thermometers, Barometers and Hydrometers. Patentee and sole manufacturer of the U. S. Standard Hydrometer. 302 Pearl Street, near Beekman.

**Thimble Manufacturers.**

**Burbank Manufg Co.**—Manufacturers of Gold and Silver Thimbles, 14 Maiden Lane, N. Y.

**Ketcham & McDougall.**—Improved Gold and Silver Thimbles, Bryant Building, N. Y.

**Simons Bro. & Co.**—Manufacturers of Gold and Silver Thimbles, 611 and 613 Sansom Street, Philadelphia.

**Woglom & Miller.**—Sole Agents for the "Prime" Thimbles in Gold and Silver, manufactured by Ezra C. Prime. 34 John Street, N. Y.

**Trunks.**

**Crouch & Fitzgerald**—Manufacturers of Trunks and Articles for Travelers' use. 1 Cortlandt St., 556 Broadway, and 723 Sixth Ave., N. Y.

**Watch Companies.**

**American Watch Co.**—Robbins & Appleton, No. 5 Bond Street, N. Y.

**Illinois Watch Co.**—Springfield, Illinois. 21 Maiden Lane, N. Y. and 71 Washington Street, Chicago, Ills.

**The E. Howard Watch and Clock Co.**—Cor. Maiden Lane and Nassau Street, N. Y.

**Waterbury Watch Co.**—Manufacturers of the Waterbury Watch. Factory, Waterbury. Office, 52 Maiden Lane, N. Y.

**Watch and Chronometer Jewelers.**

**Queen, James.**—Watch and Chronometer Jeweler and Pallet Maker, 78 Nassau Street, room 5. Pivots inserted in Pinions, Balance, Staffs, etc.

**Robert, Henry L.**—Practical Chronometer and Watch Jeweler and Adjuster. 71 Nassau Street. Pallet and Hole Jewels for Chronometer Watches done in the best manner.

**Wennstrom, John.**—Watch, Chronometer and Clock Jeweling, Jewel Gauges, Ruby and Sapphire Draw Plates; Diamond Charged Polishing Stones for Jewel Settings; Pivots inserted in Pinions. 2 Dutch Street, N. Y.

**Watch Importers, Etc.**

**Abry, Chas. Leo**—Importer and Manufacturer of Swiss Watches of all grades. 63 Nassau Street.

**Aikin, Lambert & Co.**—Importers of Watches. Sole Agents for Paul Breton & Chas. Latour, Geneva. A general line of reliable Swiss Watches, Watch Cases, etc. 23 Maiden Lane, N. Y.

**Bartens & Rice**—20 John Street, Importers of Watches and sole agents in the United States for the celebrated Nicole, Nielsen & Co. Watches.

**Cross & Beguelin.**—Importers of Watches, Watch Tools and Materials, dealers in American Watches, No. 21 Maiden Lane, N. Y.

**Droz, Henry E.**—Importer of Watches, and Watch Case Manufacturer. Agent for the "E. Perregaux" Watch, and jobber in American Watches No. 92 Fulton Street, N. Y.

**Freund Max & Co.**—Importers of Watches, Jewelry and Precious Stones, 8 Maiden Lane, N. Y.

**Gagnebin, Chas.**—Importer of all kinds of Swiss, and Dealer in American Watches. 4 Maiden Lane, N. Y. Agent for Ulysse Breting's Fine Chronometers, Chronographs, Anchors, &c.



**Gallet, Julien.**—Importer of Watches. No. 1 Maiden Lane.

**Ginnel, Henry**—Importer of Watches, Tools and Materials, 31 Maiden Lane, N. Y. P. O. Box 2967

**Hyde's Sons, John E.**—Wholesale Commission Agents, only for Jules Jurgensen, of Copenhagen; Jules Monard, of Geneva; and for other makers of all qualities of Watches, 22 Maiden Lane.

**Keller, L. H. & Co.**—Successors to G. A. Huguenin, Importers of Fine Watch and French Clock Materials, No. 64 Nassau Street, N. Y.

**Mathey Bros. & Mathez.**—Importers of Fine Watches and Sole Agents for the H. L. Matile's Watches. No. 16 Maiden Lane.

**Robert, J. Eugene**—No. 30 Maiden Lane, New York. Agent for Louis Audemar's celebrated watches.

**Schumann, Chas. W.**—No. 24 John Street, New York. Importer of Fine Diamonds, Watches, etc. Sole Agent in the U. S. for the celebrated "Lange" Dresden Watch.

**Schwob, Adolphe**—Manufacturer and Importer of Watches, 5 Maiden Lane, N. Y.

**Strasburger, Louis & Co.**—Importers and Makers of Watches of every description, 15 Maiden Lane.

#### Watch Cases.

**Dueber Watch Case Mfg Co.**—Manufacturers of Gold and Silver Watch Cases. Bryant Building, N. Y. Factory, Newport, Ky.

**Fahys, Joseph**—Manufacturer of Watch Cases and Dealer in American Movements, 38 Maiden Lane.

**Glatz, Chas.**—Manufacturer of Silver Watch Cases. Bryant Building, cor. Nassau and Liberty Sts.

**Keller & Untermeyer.**—Manufacturers of Watch Cases with Raised Gold Ornaments. 9 Maiden Lane, N. Y.

**Ladd Watch Case Co.**—Manufacturers of the Ladd Patent Stiffened Gold Watch Cases, etc., 11 Maiden Lane, N. Y. Factory, 58 Eddy Street, Providence, R. I.

**Martins & Tissot**—Manufacturers of Gold Watch Cases. No. 15 Maiden Lane, N. Y.

**The Brooklyn Watch Case Co.**—Manufacturers of the celebrated Eagle Case. 40 Maiden Lane.

**Willemin Watch Case Co.**—Makers of Gold Watch Cases. Raised Gold Ornamentation and Jurgensen style of Engine Turning. 109 Sands Street, Brooklyn, N. Y. 16 Maiden Lane, N. Y.

#### Watch and Chronometer Repairers.

**Cerf, B.**—Practical Watchmaker and Repairer, No. 10 John Street, N. Y. Repairing and adjusting of Fine Watches done for the trade. All kinds of escape and stem-winding wheels cut to order.

**Goepf, Frederick A.**—Practical Watchmaker. Repairing of every description for the Trade. 25 Maiden Lane, N. Y. In office of H. Garland, Engraver.

**Heinrich, H. H. & Co.**—Sole Manufacturers of H. H. Heinrich's Patent Auxiliary Balance, and Adjusters and Repairers of Fine Watches and Chronometers. 18 John Street, N. Y.

**La Croix, J. H.**—(Late with Benedict's Time.) Watch and Clock Maker, 21 John Street, N. Y. Clocks of every description Repaired for the Trade.

**Lesperance, Theo.**—Watchmaker and Wheel Cutter. No. 1 Maiden Lane, New York. With Julien Gallet.

#### Watch Case Repairers.

**Feinier, Joseph A.**—Watch Case Maker and General Repairer. Specialty in fine Gold and Silver Cases. Jobbing promptly attended to. Nos. 4 and 6 John St., N. Y.

**Tarbox, Hiram**—Watch Case Repairing, Springing, Polishing and Engine Turning. 1874 North Fourth Avenue, bet. 176th and 177th Sts., N. Y. Express Packages should be sent to 92 Fulton Street.

#### Watch Glasses, Shades, Etc.

**Brown, Edwin H.**—No. 85 Nassau Street, Imported and Own Manufacture Watch Glasses; Flat, Flat Concave, Concave, Convex and fine Genevas. Fine fitting solicited.

#### Watches, Diamonds and Jewelry.

**Alford, C. G. & Co.**—Manufacturers. General line fine and Reliable Goods. Specialties in Onyx Goods and Chain. 200 Broadway, New York.

**Cohn, J. J.**—Importer and Manufacturer of Whitby Jet, Rubber and Pearl goods. Gold and Rolled-plate Jewelry, etc. 12 Maiden Lane, New York.

**Durfey & Reynolds**—Successors to Durfey & Shiebler, Watches, Diamonds, Jewelry. No. 9 John Street, (up-stairs) New York.

**Goddard, John M.**—Manufacturing Jeweler,— Seal Rings and Fine Lockets a specialty, No. 3 Maiden Lane, N. Y.

**Greason J. R. & Co.**—Successors to Arthur, Rumrill & Co., 182 Broadway. Manufacturers of Fine Jewelry and Gold Chains, also Diamond Mountings.

**Haskell, H. C.**—Manufacturing Jeweler. Seal Rings a specialty. Special attention to Jobbing of every description. 12 John street.

**Herzog, Louis & Co.**—Importers of Watches, Dealers in Diamonds and Jewelry, 52 Maiden Lane, N. Y.

**Hirsch Bros.**—Dealers in Watches and Diamonds and Manufacturers of Jewelry, No. 23 Maiden Lane, N. Y.

**Jandorf, P. & Bro.**—Importers of Watches and Jewelry, 106 Broadway.

**Kennedy, Frank S.**—Manufacturer and Wholesale Dealer in Jewelry and Gold and Silver Thimbles. No. 13 Maiden Lane, New York.

**Lissauer & Sondheim**—Wholesale Jewelers and Jobbers in American Watches, No. 12 Maiden Lane, N. Y.

**Marx, Kossuth & Co.**—Importers of Watches and Dealers in Jewelry. 39 Maiden Lane, N. Y.

**May, Henry**—Importer and Wholesale Dealer in Watches and Diamonds, and Manufacturing Jeweler. 19 John St., N. Y.

**Mayer, B.**—Manufacturer of Fine Jewelry, and Dealer in Watches, 71 Nassau street, cor. John street, New York.

**Myers, S. F. & Co.**—Manufacturing and Wholesale Jewelers—all grades. Importers of Watches. Illustrated Catalogue to the trade. 179 Broadway, N. Y.

**Oppenheimer Bros. & Veith.**—Dealers in Watches and Diamonds, and Manufacturing Jewelers, No. 35 Maiden Lane.

**Scott, J. T. & Co.**—Importers of Watches, and Manufacturers of Jewelry, and Jobbers of all Grades of American Watches, 4 Maiden Lane.

**Smith & Knapp**—Wholesale Dealers in American and Swiss Watches, Diamonds, Gold and Plated Jewelry and Gold Chain. 182 Broadway, N. Y.

**Steele, J. W.**—Successor to Brainerd, Steele & Co., Manufacturer of Fine Jewelry and Brainerd's Patent Lockets. No. 9 Maiden Lane, N. Y.

**Stern Brothers & Co.**—Importers of Swiss Watches and wholesale dealers in American Watches, &c., 39 Maiden Lane.

**Stern & Stern**—Dealers in Watches, Jewelry and Diamonds. No. 6 Maiden Lane, N. Y.

**Stites, D. H. & Son**—Manufacturers of Fine Jewelry, Rolled Plated Goods and Chains, Parisian Diamond Rings, Studs and Earrings a specialty. 41 Maiden Lane, N. Y.

**Strauss, Jacob.**—Full Line of Gold and Plated Jewelry, and Importer of Watches. 18 John Street, New York.

**Thrall, E. A.**—Wholesale Dealer in Watches and Jewelry. No. 1 Maiden Lane, N. Y.

**Trier Bros.**—Importers of Garnet, Whitby Jet and Amber Jewelry, Silk Guards, Opera, Field and Marine Glasses, Pearl Card Cases. Also a full line of Gold and Plated Jewelry. 15 Maiden Lane, N. Y.

**Wheeler, Parsons & Hays.**—Manufacturers of Fine Jewelry, Watch Cases, Gold Chains, &c. and Dealer in American and Swiss Watches, No. 2 Maiden Lane, N. Y.

**White, N. H.**—Jobber in American-Waltham Watches and Chronographs. Waltham make of 10-k., 14-k. and 18-k. Gold and Sterling Silver Cases; Filled Gold Cases. 11 Maiden Lane.

#### Watch Tools, etc.

**Keller, L. H. & Co.**—Importers of Watchmakers' and Jewelers' Tools, Materials, etc. 64 Nassau Street, N. Y.

**Zimmern, Henry**—Importer of Watch Materials, Tools, and Optical Goods, No. 8 Maiden Lane, (first floor.) Sole Agent for A. Huguenin & Gravier. Mainsprings, New York.

### PHILADELPHIA

**Bennett, Jacob & Son.**—Diamond Setters and Manufacturing Jewelers, 925 Chestnut St.

**Bernard & Co.**—Manufacturers of Fine Roman and Etruscan Jewelry. Designs of every description made to order, 123 & 125 South Eleventh Street, Philadelphia.

**Booz & Co.**—Makers of Fine Gold Watch Cases and Plain Gold Rings, also Dealers in all American Movements, Diamonds, Jewelry, etc. 108 South 8th Street, Philadelphia.

**Conover David F. & Co.**—American Watches, Wholesale Salesroom, Southeast corner 7th and Chestnut Streets, Philadelphia.

**Herold, Chas P.**—Successor to Hildebrandt, Herold & Co., Manufacturing Jeweler and Diamond Setter. Diamonds. 916 Chestnut Street.

**Krieder, Peter L.**—Manufacturer of Sterling Silver Ware. 618 Chestnut Street, Philadelphia.

**McCall & Newman**—Manufacturing Jewelers. Makers of the Original Gold Crown Filled Rings. No. 625 Arch St., Philadelphia.

**Morgan & Headly.**—Manufacturing Jewelers. Cameo Sets, Gold Sets, Roman Lockets, Rings, Coral Sets and a general line of rich goods. Corner 10th and Chestnut Streets, Philadelphia.

**Muhr's, H., Sons.**—Manufacturing Jewelers. Solid Gold and Filled Rings a specialty. 633 and 635 Chestnut Street, Philadelphia. 14 Maiden Lane, New York.

**Peters, Reese S.**—Manufacturer of Patent Rolled Plate or Filled Watch Cases, Dealer in American Movements, 308 Chestnut Street, Philadelphia.

**Rosenthal, G. F. C.**—Manufacturing Jeweler and Diamond Setter. Engraving and Designing of Monograms a specialty. No. 917 Sansom Street.

**Scherr, L. A. & Co.**—Wholesale Dealers in Watches Silver-Plated Ware, Spectacles, Fancy Goods, Watch Materials, etc. 726 Chestnut Street.

**Shearer, W. H. & Co.**—Manufacturing Jewelers. Specialty: Band Bracelets. Factory, 612 and 614 Chestnut street, Philadelphia. Office, 15 John street, New York.

**Simons, Brother & Co.**—Manufacturers of Fine Jewelry, Canes, Thimbles, Chains. 611 and 613 Sansom Street.

### CHICAGO.

**American Watch Company**,—of Waltham, Mass. No. 102 State Street, Chicago.

**Clapp & Davies**—Wholesale Jewelers, 63 and 65 Washington Street. Catalogue and price list issued to watchmakers and jewelers.

**Dennison Manufacturing Co.**—Manufacturers of Jewelers' Paper Boxes, Morocco Cases, Tags, Cards, Pink and White Cotton, Tissue Papers, Sealing Wax, &c., &c., 102 Madison St., Chicago. Boston, New York, St. Louis, and Philadelphia.

**Gilbert, Wm. L., Clock Co.**—Manufacturers of Clocks, Regulators, and Time Pieces, and Clock Material of every description, 54 and 56 Madison Street, Chicago.

**Giles, Bro. & Co.**—Manufacturers and Jobbers in Watches, all classes of Jewelry, Materials, Clocks, Silver Ware, &c. Illustrated catalogues furnished to dealers on application. 101 & 103 State St.

### NEWARK.

**Baker & Co.**—Gold, Silver and Platinum Refiners Assayers and Sweep Smelters. 408 New Jersey Railroad Avenue, cor. Murray St., Newark, N. J.

**Diefenthaler Bros. & O'Donnell**—Manufacturers of Fine Jewelry, Lace Pins, Ear Rings and Patent Spring Bangles a Specialty. 36 Crawford Street, Newark, N. J.

**English & Miller**—Manufacturers of Gold Jewelry, Diamond and Fancy Stone Rings, Roman Lockets, Bangle and Flexible Bracelets, Knife Edge Lace Pins and Sets, Scarf Pins and Link Buttons. 61 and 63 Hamilton St., Newark.

**Felger, F. & F.**—Manufacturing Jewelers. Specialties:—Roman Band Bracelets, Lace Pins, Scarf Pins, Ball and Fancy Ear Rings. No. 477 Washington Street, Newark, N. J.

**Fiedler, Herrman**—Successor to Kunze & Fiedler, Engraver, Die Sinker and Press Tool Maker, 363 Market Street, Opposite Pennsylvania R. R. Depot, Newark, N. J.

**Glorieux, W. L.**—Assayer, Refiner and Sweep Smelter. 13 and 15 Franklin Street, Newark, N. J.

**Hopper & Wilson**—Manufacturers of Fine Jewelry, No. 8 Maple Place, Rear 44 Green St., Newark, N. J.

**Huger & Heitlinger**—Manufacturers to the Jobbing Trade only. Makers of Roman, Stone, Engraved and Enameled Lockets a specialty. Also Sleeve Buttons, Collar Buttons and Studs. 477 Washington Street, Newark, N. J.

**Krippendorf, C. & Schuller, F.**—Machinists and Jewelers' Tool Makers. 19 Greene Street, Newark, N. J. Rolls, Dies, Cutters, and Draw-plates of every Description made and repaired.

**Lelong, L. & Bro.**—Gold and Silver Refiners Assayers and Sweep Smelters, Southwest corner of Halsey and Marshall Streets, Newark, N. J.

**Milne, Alex.**—Manufacturer of Stem-winding Watch Crowns. 19 Ward Street.

**Nesher & Co.**—Manufacturers of 18 Kt. Gold Filled Hoop Ear Rings, Plain, Facet and Engraved, all sizes. 36 Crawford St., Newark, N. J.

**Regad, E. D.**—Lapidary. Specialty—Sardonyx, Black Onyx and Agates. 14 Oliver St., Newark.

## PROVIDENCE

**Arnold & Webster**—Manufacturers of Solid Gold Engraved Band Rings for the Jobbing Trade. 29 Point Street, Providence, R. I.

**Butts, Geo. F.**—Manufacturing Jeweler. Ladies' and Misses' Solid Gold Drops and Studs a Specialty. 119 Orange Street, Providence, R. I.

**Bradley, R. & Son**—Manufacturers of Solid Gold and Rolled Plate Jewelry. White Stone Goods a Specialty. 227 Eddy Street, Providence, R. I.

**Capron & Co.**—Manufacturers of Jewelry. Engraved Box Bracelets, Bangle Wire Bracelets, Original Lever Collar and Cuff Button. No. 407 Pine Street, Providence, R. I.

**Elmwood Paper Box Co.**—Makers of Jewelers' Cases, Trays, etc. Factory, 54 Greenwich St., Providence, R. I.

**Fry & Read**—Manufacturers of Sterling Silver and Gold Plated Jewelry. Antique Work a Specialty. 25 Potter Street, Providence, R. I.

**Hamilton, William & Co.**—Manufacturers of Fine Rolled Plated Chains and Patent Band Bracelets. 116 Pine St., Providence, R. I.

**Harrington, J. C.**—Maker of Fine Gold Plated Jewelry. Specialties:—Oval Wire Bangles, Band Bracelets and the Victor Swivel. 129 Eddy St., Providence, R. I.

**Hough, W. S., Jr., & Co.**—Manufacturers of the Hough, Jr., Rolled Plate Lockets, Charms and Pendants. For sale by all first-class Jobbers or Wholesale Jewelers in the United States and Canadas.

**Hutchison & Huestis**—Makers of Solid Gold Rings. Quality guaranteed. For the Jobbing Trade only. 185 Eddy Street, Providence, R. I.

**Irons, Chas. F.**—Manufacturer of Solid Gold Jewelry. Specialty, Emblems, Pins and Charms, Masonic, Odd Fellows, etc. 102 Friendship St.

**Pitts & Hicks**—Manufacturers of the Excelsior Button and Eclipse Lever Button, also a line of White Stone Gold Goods and a fine line of Lace Pins and Drops in Rolled Plate Goods. 120 Dorrance Street, Providence, R. I.

**Taylor, Geo. H. & Co.**—Watchmakers and Wholesale Dealers in Watches, Clocks, Watch and Clock Material, Tools, Spectacles, Eye Glasses, &c. Particular attention given to trade work. 136 Westminster Street (Room 1), Providence, R. I.

**Waite, Smith & Co.**—Manufacturers of Gold and Plated Jewelry. Gold Chain Trimmings a Specialty. Plated Stone Rings. White Stone Goods. 61 Peck Street, Providence, R. I.

## PAWTUCKET.

**Fuller, Geo. H. & Son**—Jewelers' Findings, Gold, Silver, Gold Plated and Fire Gilt. Pin Stems, Joints, Catches, Split Rings, Chain Hooks and Swivels, Ear Wires, Chain Bars, etc. 99 Exchange Street, Pawtucket, R. I.

## CINCINNATI.

**Holland, John**—Manufacturer of Gold Pens, Pencils and Pencil Cases, Gold Toothpicks, etc. Nos. 19 and 21 W. 4th St., Cincinnati, Ohio.

**Lodwick & Nolling**—Wholesale Jewelers (exclusively), S. W. cor. Fourth and Walnut Streets, Cincinnati, Ohio.

## BOSTON.

**Boston Watch Case Co.**, makers of Watch Cases. Especial attention given to Repairing. 1, 3 & 5 Province Court, Boston, Mass.

**Boyce, E. J.**—Manufacturer of Solid Gold Jewelry. Rings a Specialty. 383 Washington St., Boston, Mass.

**Thiery Watch Case Co.**—Sole Manufacturers in the United States of: Solid Nickel and Nickel Silver Cases. 309 Washington Street, Boston, Mass.

**Weber, H. & Co.**—Wholesale Jewelers, Importers and Jobbers of Fine Watch Materials, Jewelers' Findings, Tools, etc., Optical Goods and Silk Guards. Agents for Whitcomb, Standard and Stark's Lathes. 424 Washington St., Boston, Mass.

## BUFFALO.

**Klein, E. F. O.**—Jobber in Watch Materials. Watches and Chronometers repaired and adjusted for the trade; also Gold and Silver Plating. Sample Bottle of "Magic Solution," for cleaning Watches, including receipt, to any address, on receipt of \$1.50. This is a great time-saver and does the finest work. No one will do without it if used once. 346 Broadway, Buffalo, N. Y.

**Oliver, W. W.**—Manufacturer of Hand and Power Rolling Mills for Jewelers and Silversmiths, 39 Clinton Street, Buffalo, N. Y.

## CLEVELAND.

**Chandler, J. M. & Co.**—Manufacturers of the Patent Embossed Bracelet and Jobbers in all kinds of Clocks, Watches, Jewelry, Tools, Materials, etc. 185 Superior St., Cleveland, O.

## LANCASTER.

**Powman & Musser**—Jobbers in Watches, Clocks, Chains, Fine Tools and Materials. 20 East Chestnut Street, Lancaster, Pa.

## PITTSBURGH.

**Barrett, G. B., & Co.**—Wholesale Jewelers and Diamond Importers. We carry a line of everything required by the trade. Lowest prices guaranteed. 101 Fifth Avenue, Pittsburgh, Pa.

**Goddard, Hill & Co.**—Wholesale Dealers in American Watches, Jewelry, Silverware, Clocks, Materials, &c., 43 Fifth Avenue, Pittsburgh, Pa.

**Hodge, Slemmons & Co.**—Wholesale Dealers in American and Swiss Watches, Diamonds, Gold and Plated Jewelry, Clock Material, etc. No. 77 Fifth Ave., Pittsburgh.

## NEW BEDFORD.

**Nye, W. F.**—Manufacturer of Watch, Clock and Chronometer Oils, New Bedford, Mass.

**Wheeler, G. B.**—Manufacturer of Watch and Chronometer Oils, New Bedford, Mass.

## WORCESTER.

**Washburn & Moen Manufacturing Co.**—Makers of Fine Watch Mainsprings, Worcester, Mass. 16 Cliff Street, New York. 107 to 109 Lake Street, Chicago, Ill.

## WINCHESTER.

**Goodell & Winn**—Manufacturers of American Watch Hands, Winchester, Mass.

## ALBANY.

**Reiss, Chas.**—31 and 33 So. Pearl Street, Albany, N. Y. Importer of Watch Tools and Material; General Supply; Low Prices. Repairing for the Trade.

## KEOKUK, IOWA.

**Ayres, T. R. J., & Sons**—Wholesale Jewelers. Watches, Jewelry, Diamonds, Silverware, Clocks, Optical Goods, Tools, Material, &c. at lowest eastern prices. Correspondence solicited.

## CANADA.

**Ellis, P. W. & Co.**, No. 31 King street, East Toronto, Ontario, Manufacturing Jewelers, Watchmakers, importers and Jobbers of Watchmakers, and Jewelers' Tools, Materials, General Supplies and American Jewelry. Correspondence solicited with manufacturers of Novelties or specialties in American Tools and Jewelry.

GEO. W. DUBOIS.

F. N. NAUMAN.

## GEO. W. DUBOIS & CO.,

IMPORTERS OF

## Watches & Optical Goods.

ALL STYLES AND QUALITIES OF

SPECTACLES AND EYE-GLASSES.

## Longines' Watches and Movements,

The Watches in Gold, Silver and Nickel Cases of New and Handsome Patterns. The Movements fit 18 size Waltham Stem Winding Hunting Cases.

36 Maiden Lane, New York.

ORDERS BY MAIL RECEIVE PROMPT ATTENTION.

## BARNES' No. 4 LATHE, For the Heavier Work of Jewelers.

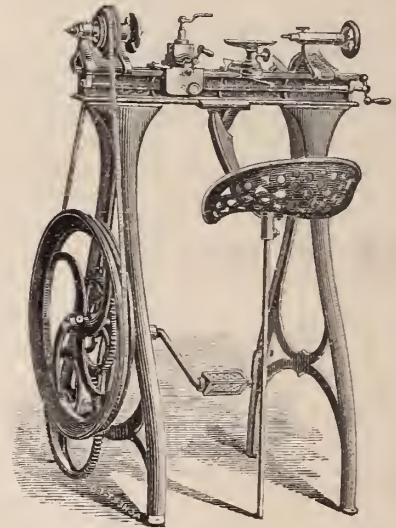

Barnes' Patent Foot and Steam Power Machinery. Complete outfits for Actual Workshop Business. Lathes for wood or metal. Circular Saws, Scroll Saws, Formers, Mortisers, Tenoners, etc., etc. Machines on trial if desired. Descriptive Catalogue and Price List Free.

W. F. & JOHN BARNES,  
2088 Main Street, ROCKFORD, ILL.

## American Lens Mfg. Co.,

MANUFACTURERS OF

## Optical and Object Lenses

OF ALL KINDS.

KATONAH, N. Y.

Spectacle Lenses a Specialty.

THE BEST!  THE STRONGEST!  
**COLLAR BUTTON,**

MADE FROM ONE PIECE OF GOLD WITHOUT SOLDER.

THREE SIZES, POLISHED OR ROMAN GOLD. LONG OR SHORT POSTS.  
 SET WITH DIAMOND, RUBY, PEARL OR TURQUOISE.



EAR STUDS WITH PATENT FASTENERS.

**KREMENTZ & CO.,**

MANUFACTURERS OF

**GOLD, PEARL AND DIAMOND JEWELRY,**  
 Nos. 182 and 184 BROADWAY,  
 Corner of John Street, NEW YORK.

(Elevator Entrance on John Street.)

FACTORY, NEWARK, N. J.

**S. DESSAU,**

IMPORTER OF ROUGH AND POLISHED

**DIAMONDS & PRECIOUS STONES**

DIAMOND CUTTING AND POLISHING WORKS AT No. 4 MAIDEN LANE, N. Y.

Paris House,  
 15 Rue de Chateaudun,  
 PARIS.

**TO THE TRADE.**

*I have established at the above address a Branch House, where will be found a full and complete stock of*

—❖— **Diamonds** —❖—

AND

**PRECIOUS STONES,**

*Single Stones, Matched Pairs, Loose Stones and Original Packages, and all goods of this character required by the Trade.*



*Matching, repairing and Repolishing for the Trade at greatly reduced prices by the finest workmen.*

Selection Packages sent upon Application with Satisfactory Reference.

*Carbon (Black Diamond), Bort and Diamond Powder always on hand.*

To the Editor of the Jewelers' Circular:

As my annual report has been delayed beyond the time of its appearance in preceding years, I send you a proof sheet of the watch CIRCULAR.

Yours truly,

ABSTRACT OF THE RESULTS OF THE TRIALS OF THE WATCH MOVEMENTS AT THE YALE COLLEGE OBSERVATORY DURING THE YEAR CLASS I. CER-

| Rank. | MAKER'S NAME.                       | Maker's Number. | Adjusted by               | Escapement.    | Spring.       | Mean Daily Rate | Mean daily variation. | Variation for 1° Fahr | Diff. before and after oven and refrigerator. | Diff. bet. Pendant up and Dial up. |
|-------|-------------------------------------|-----------------|---------------------------|----------------|---------------|-----------------|-----------------------|-----------------------|---|------------------------------------|
| 1     | American Watch Co., Waltham, Mass   | 1560072         | American Watch Co.....    | Lever.....     | Flat .....    | +3.27           | 0.38                  | 0.00                  | -0.59   | +0.41                              |
| 2     | Paul Breton, Geneva.....            | 12187           | H. H. Heinrich, N. Y....  | Lever.....     | Breguet. .... | -0.47           | 0.35                  | +0.04                 | -0.65   | +0.50                              |
| 3     | Karl Zimmerman, Liverpool. ....     | 15690           | H. H. Heinrich, N. Y....  | Lever, Fusee.  | Breguet. .... | +0.64           | 0.47                  | +0.03                 | -0.45   | -1.43                              |
| 4     | Karl Zimmerman, Liverpool.....      | 15682           | H. H. Heinrich, N. Y....  | Lever, † ..... | Breguet. ...  | -0.27           | 0.49                  | -0.012                | +0.28   | -1.81                              |
| 5     | J. Jurgensen, Copenhagen.....       | 10852           | M. Cooper .....           | Lever.....     | Breguet. .... | -2.64           | 0.44                  | -0.03                 | -0.47   | -5.80                              |
| 6     | American Watch Co., Waltham, Mass   | 1561793         | American Watch Co.....    | Lever.....     | Flat .....    | +1.80           | 0.52                  | -0.03                 | -0.77   | -0.19                              |
| 7     | American Watch Co., Waltham, Mass   | 1561690         | American Watch Co.....    | Lever.....     | Flat .....    | +2.60           | 0.60                  | +0.006                | +2.63   | +0.64                              |
| 8     | Albert H. Potter & Co., Geneva..... | 609             | Albert H. Potter & Co.... | Anchor .....   | Breguet. .... | -0.29           | 0.41                  | +0.10                 | -0.08   | +0.85                              |
| 9     | Karl Zimmerman, Liverpool....       | 15620           | Geo. E. Wilkins .....     | Lever.....     | Breguet. ..   | -3.44           | 0.52                  | -0.03                 | +0.30   | -5.03                              |
| 10    | Paul Breton, Geneva.....            | 12319           | H. H. Heinrich, N. Y....  | Lever.....     | Breguet. .... | +2.07           | 0.49                  | +0.04                 | -0.24   | +4.32                              |
| 11    | Edouard Richard, Locle.....         | 42940           | F. G. Crandale, N. Y....  | Lever.....     | Breguet. ...  | -2.25           | 0.74                  | +0.05                 | +0.49   | -0.61                              |
| 12    | American Watch Co., Waltham, Mass   | 1561695         | American Watch Co.....    | Lever.....     | Flat .....    | -1.06           | 0.40                  | +0.073                | -1.16   | -2.78                              |
| 13    | American Watch Co., Waltham, Mass   | 1561687         | American Watch Co.....    | Lever.....     | Flat .....    | -0.44           | 0.40                  | -0.094                | -0.17   | +1.63                              |
| 14    | W. G. Schoof.....                   | 6052            | Geo. E. Wilkins .....     | Schoof's Res.  | Breguet. .... | +0.85           | 0.74                  | +0.004                | +0.42   | -3.54                              |
| 15    | Paul Breton, Geneva.....            | 12078           | H. H. Heinrich, N. Y....  | Lever.....     | Breguet. .... | -0.68           | 0.60                  | -0.06                 | -1.06   | -1.22                              |
| 16    | American Watch Co., Waltham, Mass   | 999930          | American Watch Co.....    | Lever.....     | Breguet. .... | -0.05           | 0.53                  | -0.023                | +0.10   | -2.11                              |
| 17    | Paul Breton, Geneva.....            | 12178           | H. H. Heinrich, N. Y....  | Lever.....     | Breguet. .... | -1.37           | 0.72                  | -0.08                 | -0.65   | +2.16                              |
| 18    | Albert H. Potter & Co., Geneva..... | 612             | Albert H. Potter & Co.... | Anchor .....   | Breguet. .... | +0.73           | 0.49                  | -0.09                 | -0.35   | -0.05                              |
| 19    | Paul Breton, Geneva.....            | 12406           | H. H. Heinrich, N. Y....  | Lever.....     | Breguet. .... | —*              | 0.62                  | -0.01                 | -0.16   | +2.63                              |
| 20    | Edouard Richard, Locle.....         | 42941           | F. G. Crandale, N. Y....  | Lever.....     | Breguet. .... | -6.21           | 0.84                  | +0.07                 | -0.29   | +1.07                              |
| 21    | Paul Breton, Geneva.....            | 12180           | H. H. Heinrich, N. Y....  | Lever.....     | Breguet. .... | -6.76           | 0.76                  | -0.04                 | +1.28   | -3.64                              |
| 22    | Edouard Richard, Locle.....         | 16966           | F. G. Crandale, N. Y....  | Lever.....     | Breguet. .... | -2.71           | 0.56                  | +0.14                 | +1.11   | +2.57                              |
| 23    | Edouard Richard, Locle.....         | 16379           | F. G. Crandale, N. Y....  | Lever.....     | Breguet. .... | +5.04           | 0.89                  | +0.09                 | -0.64   | -1.18                              |
| 24    | Karl Zimmerman, Liverpool.....      | 15698           | Geo. E. Wilkins .....     | Lever.....     | Breguet. .... | +0.08           | 0.69                  | +0.003                | -0.04   | +2.54                              |
| 25    | American Watch Co., Waltham, Mass   | 871189          | American Watch Co.....    | Lever. ....    | Breguet. ...  | +1.04           | 0.41                  | -0.15                 | +0.26   | -1.27                              |
| 26    | Karl Zimmerman, Liverpool.....      | 357             | H. H. Heinrich, N. Y....  | Lever.....     | Breguet. .... | -0.54           | 0.64                  | +0.126                | +0.83   | -2.50                              |
| 27    | American Watch Co., Waltham, Mass   | 1427902         | American Watch Co.....    | Lever.....     | Flat .....    | -3.20           | 0.89                  | +0.042                | -1.47   | -2.96                              |
| 28    | American Watch Co., Waltham, Mass   | 871181          | American Watch Co. ....   | Lever.....     | Breguet. ...  | -0.39           | 0.82                  | -0.01                 | -1.24   | +5.49                              |
| 29    | Paul Breton, Geneva.....            | 12410           | H. H. Heinrich, N. Y....  | Lever.....     | Breguet. ...  | -0.66           | 0.54                  | +0.09                 | +0.32   | -9.16                              |
| 30    | Paul Breton, Geneva.....            | 12318           | H. H. Heinrich, N. Y....  | Lever.....     | Breguet. .... | -4.45           | 0.71                  | +0.033                | -0.34   | -7.31                              |
| 31    | American Watch Co., Waltham, Mass   | 1427914         | American Watch Co.....    | Lever... ..    | Breguet. .... | +0.44           | 0.79                  | +0.09                 | -0.87   | +0.07                              |
| 32    | Paul Breton, Geneva.....            | 12182           | H. H. Heinrich, N. Y....  | Lever.....     | Breguet. .... | -4.79           | 0.77                  | -0.07                 | +1.16   | -4.99                              |
| 33    | Edouard Richard, Locle.....         | 42950           | F. G. Crandale, N. Y....  | Lever.....     | Breguet. .... | -4.05           | 0.72                  | -0.11                 | +0.46   | +6.16                              |
| 34    | Edouard Richard, Locle.....         | 42951           | F. G. Crandale, N. Y....  | Lever.....     | Breguet. .... | +5.17           | 0.69                  | +0.09                 | +0.46   | +1.05                              |
| 35    | Paul Breton, Geneva.....            | 12179           | H. H. Heinrich, N. Y....  | Lever.....     | Breguet. .... | -1.92           | 0.82                  | -0.06                 | -0.18   | -3.87                              |
| 36    | Paul Breton, Geneva.....            | 12408           | H. H. Heinrich, N. Y....  | Lever.....     | Breguet. .... | -2.90           | 0.59                  | -0.13                 | +0.20   | -1.65                              |
| 37    | J. Jurgensen, Copenhagen.....       | 14026           | H. H. Heinrich, N. Y....  | Lever.....     | Breguet. ...  | —*              | 0.76                  | +0.09                 | +0.30   | -1.17                              |
| 38    | Edouard Richard, Locle.....         | 43001           | F. G. Crandale, N. Y....  | Lever.....     | Breguet. ...  | -1.64           | 0.79                  | +0.18                 | -1.05   | +1.71                              |
| 39    | Edouard Richard, Locle.....         | 42999           | F. G. Crandale, N. Y....  | Lever.....     | Breguet. ...  | +3.81           | 0.92                  | +0.22                 | -3.03   | -4.64                              |

\* Rate larger than 10<sup>s</sup>o.

Yale College Observatory.

YALE COLLEGE OBSERVATORY, NEW HAVEN, November 18th, 1884.  
 Rating results for the Class I. Certificates for the year ending June 1st, 1884, in the hope that it may reach you in time for this month's  
 LEONARD WALDO.

ENDING JUNE 1, 1884, OBSERVED FOR 42 DAYS, IN FIVE POSITIONS, AND IN THE OVEN AND REFRIGERATOR, AND WHICH RECEIVED CERTIFICATES.

| Diff. bet. Pendant up and Pendant right. | Diff. bet. Pendant up and Pendant left. | Diff. Dial up and Dial down. | Diff. first and last weeks. | Diff. bet. extremes of rate. | MARK COMPUTED FOR |           |             | TOTAL. | Recorded. | RECEIVED FROM                          |
|--|---|------------------------------|-----------------------------|------------------------------|-------------------|-----------|-------------|--------|-----------|--|
|  |   |                              |                             |                              | Daily Variation.  | Position. | Temperature |        |           |  |
| +0.83                                    | +0.68                                   | -1.38                        | +0.08                       | 4.4                          | 32.4              | 38.0      | 20.0        | 90.4   | 330       | The American Watch Co., Waltham, Mass. |
| +3.84                                    | +2.99                                   | +1.34                        | +0.50                       | 4.6                          | 33.0              | 34.9      | 17.3        | 85.2   | 320       | Aikin, Lambert & Co., New York.        |
| +0.15                                    | -1.43                                   | +2.76                        | -0.36                       | 5.0                          | 30.6              | 36.5      | 18.0        | 85.1   | 371       | H. H. Heinrich, New York.              |
| -1.67                                    | +1.23                                   | +2.39                        | -0.63                       | 4.0                          | 30.2              | 35.6      | 19.2        | 85.0   | 373       | H. H. Heinrich, New York.              |
| -3.35                                    | -3.00                                   | +1.35                        | -0.48                       | 7.6                          | 31.2              | 34.2      | 18.0        | 83.4   | 328       | J. R. Cramer, New Haven.               |
| -1.61                                    | -3.51                                   | -2.02                        | -2.90                       | 5.7                          | 29.6              | 35.5      | 18.0        | 83.1   | 340       | The American Watch Co., Waltham, Mass. |
| +0.91                                    | -2.24                                   | +2.17                        | +2.10                       | 5.2                          | 28.0              | 35.0      | 19.6        | 82.6   | 337       | The American Watch Co., Waltham, Mass. |
| +3.42                                    | +1.77                                   | -2.27                        | +0.22                       | 5.3                          | 31.8              | 35.4      | 13.3        | 80.5   | 366       | Burger & Co., New York.                |
| -4.87                                    | -2.37                                   | +0.16                        | +1.40                       | 10.6                         | 29.6              | 32.8      | 18.0        | 80.4   | 357       | Geo. E. Wilkins, Syracuse, N. Y.       |
| +8.49                                    | +4.74                                   | +0.47                        | -0.37                       | 10.2                         | 30.2              | 32.6      | 17.3        | 80.1   | 352       | Aikin, Lambert & Co., New York.        |
| -1.62                                    | -1.72                                   | -0.36                        | -0.75                       | 4.1                          | 25.2              | 37.8      | 16.7        | 79.7   | 383       | Mathey Bros. & Mathez, New York.       |
| -1.52                                    | +1.73                                   | -2.34                        | -2.90                       | 7.5                          | 32.0              | 32.3      | 15.1        | 79.4   | 338       | The American Watch Co., Waltham, Mass. |
| -1.37                                    | +1.53                                   | +2.95                        | -0.45                       | 9.1                          | 32.0              | 33.7      | 13.7        | 79.4   | 336       | The American Watch Co., Waltham, Mass. |
| +2.59                                    | +4.21                                   | +0.40                        | +2.49                       | 9.6                          | 25.2              | 33.8      | 19.7        | 78.7   | 363       | Geo. E. Wilkins, Syracuse, N. Y.       |
| -4.19                                    | -4.09                                   | -1.42                        | +0.06                       | 5.7                          | 28.0              | 34.0      | 16.0        | 78.0   | 317       | Aikin, Lambert & Co., New York.        |
| -0.23                                    | +3.62                                   | -8.83                        | -1.61                       | 10.4                         | 29.4              | 28.6      | 18.5        | 76.5   | 343       | The American Watch Co., Waltham, Mass. |
| +1.68                                    | +5.18                                   | -0.28                        | -0.87                       | 7.4                          | 25.6              | 35.2      | 14.7        | 75.5   | 318       | Aikin, Lambert & Co., New York.        |
| +6.12                                    | -0.83                                   | -3.47                        | +0.83                       | 8.0                          | 30.2              | 30.3      | 14.0        | 74.5   | 367       | Burger & Co., New York.                |
| -3.50                                    | +8.85                                   | +1.77                        | -1.58                       | 12.8                         | 27.0              | 26.4      | 19.6        | 73.6   | 322       | Aikin, Lambert & Co., New York.        |
| +3.84                                    | -0.01                                   | -0.07                        | +2.13                       | 7.1                          | 23.2              | 34.9      | 15.3        | 73.4   | 384       | Mathey Bros. & Mathez, New York.       |
| -6.72                                    | -1.87                                   | -2.03                        | +3.93                       | 12.5                         | 24.8              | 31.0      | 17.3        | 73.1   | 356       | Aikin, Lambert & Co., New York.        |
| +4.27                                    | +2.32                                   | -3.35                        | +2.76                       | 10.9                         | 28.8              | 33.4      | 10.7        | 72.9   | 351       | Mathey Bros. & Mathez, New York.       |
| -2.34                                    | -3.94                                   | +0.39                        | -1.36                       | 7.5                          | 22.2              | 36.1      | 14.0        | 72.3   | 385       | Mathey Bros. & Mathez, New York.       |
| -5.31                                    | -5.71                                   | +1.45                        | +1.43                       | 9.9                          | 26.2              | 26.1      | 19.8        | 72.1   | 372       | Geo. E. Wilkins, Syracuse, N. Y.       |
| +0.71                                    | +8.06                                   | +2.68                        | +0.79                       | 11.6                         | 31.8              | 30.0      | 10.0        | 71.8   | 342       | The American Watch Co., Waltham, Mass. |
| 0.00                                     | +2.60                                   | -1.40                        | +1.14                       | 8.4                          | 27.2              | 33.0      | 11.6        | 71.8   | 348       | H. H. Heinrich, New York.              |
| -0.27                                    | +0.43                                   | -2.41                        | -0.28                       | 8.5                          | 22.2              | 31.9      | 17.3        | 71.4   | 345       | The American Watch Co., Waltham, Mass. |
| -3.05                                    | -1.30                                   | -1.69                        | -3.13                       | 12.0                         | 23.6              | 28.3      | 19.3        | 71.2   | 346       | The American Watch Co., Waltham, Mass. |
| -9.61                                    | -9.66                                   | +0.35                        | 1.52                        | 11.9                         | 29.2              | 27.9      | 14.0        | 71.1   | 353       | Aikin, Lambert & Co., New York.        |
| +0.08                                    | +0.15                                   | +1.34                        | -1.91                       | 11.8                         | 25.8              | 27.1      | 17.8        | 70.7   | 351       | Aikin, Lambert & Co., New York.        |
| +0.31                                    | -6.04                                   | -0.46                        | -1.21                       | 11.7                         | 24.2              | 32.3      | 14.0        | 70.5   | 347       | The American Watch Co., Waltham, Mass. |
| -2.40                                    | -8.10                                   | -1.21                        | +0.09                       | 9.4                          | 24.6              | 29.9      | 15.3        | 69.8   | 350       | Aikin, Lambert & Co., New York.        |
| +5.91                                    | +7.11                                   | +1.70                        | -6.59                       | 13.7                         | 25.6              | 31.1      | 12.7        | 69.4   | 381       | Mathey, Bros. & Mathez, New York.      |
| +5.83                                    | -3.17                                   | +1.63                        | +1.71                       | 10.0                         | 26.2              | 28.6      | 14.0        | 69.4   | 382       | Mathey Bros. & Mathez, New York.       |
| +0.01                                    | -6.69                                   | -1.92                        | -4.81                       | 12.3                         | 23.6              | 29.5      | 16.0        | 69.1   | 319       | Aikin, Lambert & Co., New York.        |
| -6.39                                    | +1.61                                   | +4.36                        | +1.09                       | 9.9                          | 28.2              | 29.5      | 11.3        | 69.0   | 321       | Aikin, Lambert & Co., New York.        |
| -2.76                                    | -10.41                                  | -0.94                        | -4.86                       | 15.1                         | 24.8              | 28.6      | 14.0        | 67.4   | 327       | H. H. Heinrich, New York.              |
| +1.06                                    | +0.96                                   | +6.59                        | -0.09                       | 12.2                         | 24.2              | 30.5      | 8.0         | 62.7   | 378       | Mathey Bros. & Mathez, New York.       |
| +3.97                                    | 0.82                                    | +4.21                        | 9.87                        | 14.8                         | 21.6              | 28.3      | 5.3         | 55.2   | 380       | Mathey Bros. & Mathez, New York.       |

† Heinrich's Patent Auxiliary Balance.

# THE CLIMAX REVERSIBLE WATCH CASE,

MANUFACTURED BY THE

## Northwestern Watch Case Company, of Rockford, Illinois.

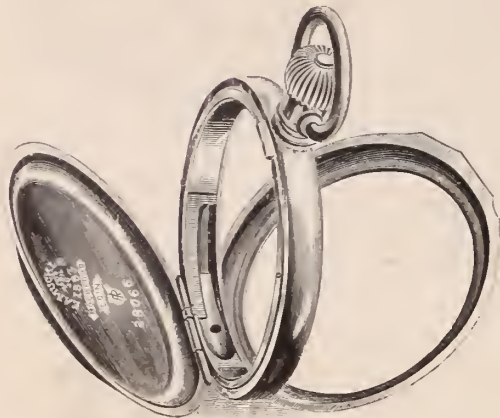

The outer case, in which the inner case containing movement is placed.

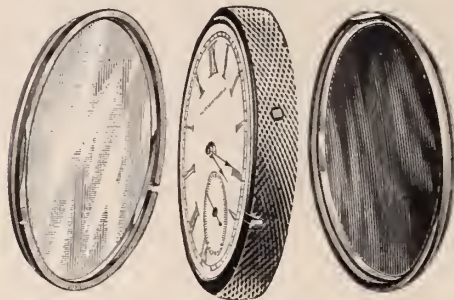

- (1) The bezel and glass which snaps on inside center over dial.
- (2) The inside center in which watch movement is fitted.
- (3) The cap which snaps on inside center over back of movement.



The two cases combined, and being changed from an Open Face to a Hunting Case.

A PERFECT DUST-PROOF WATCH CASE; STEM WINDING AND STEM SETTING; CHANGED FROM AN OPEN FACE TO A HUNTING CASE, OR FROM A HUNTING CASE TO AN OPEN FACE, WITHOUT THE TURN OF A SCREW.

Made in both Gold & Silver to fit all 18 Size American Stem Wind Movements, also the 16 Size Elgins.

**SOLD BY ALL WHOLESALE JEWELERS.**

### VERDICT OF THE TRADE IN THE CASE OF WATHIER'S

## PATENT SELF-ADJUSTING



## HAIR SPRING STUD INDEX

(PRICE, **\$1.25.**)

Confirms the fact that it is one of the most useful and convenient tools to the Watchmaker, and in view of its time-saving feature and absolute reliability as an indicator of the proper position of the Hair Spring Stud for the various makes of American watches, it is **valuable** to the most expert workman as it is **invaluable** to those who have more or less difficulty in putting watches in beat. We submit a few of the numerous testimonials received from leading Watchmakers:

Enclosed find \$1.25 for Index. We think it a good tool and worth many times its price to any jeweler.  
MENDOTA, Ill., July 9, 1884.  
H. MUNSON, Watchmaker and Jeweler.

Enclosed find draft for \$1.25 for Hair Spring Stud Index, with which we are more than satisfied. We can heartily recommend this tool to the trade. You could offer to refund the price to any one not fully satisfied, and we venture to say you would not be called upon to do so **in 20 years** by any honorable man. Hoping your invention will receive what it richly deserves, we are,  
YAKIMA, Wash. Ter., July 2, 1884.  
Yours respectfully, REDFIELD BROS.

I received your Hair Spring Stud Index by mail. Delayed to answer because I wanted to thoroughly test it before doing so, and it takes some time for the various makes of watches indicated on it to come in in the regular course of bench work. At first I thought I had no use for it, having worked at the bench over 40 years—from the old rack and pinion lever down. I have always been in the habit of testing each watch as regards its being in beat, and I thought I had no use for such a tool. But having tested it and found it always correct, I soon found that the saving of time makes it invaluable, even if there be no need of any help to put a watch in beat. As such a **timesaver it is valuable to the most expert workman, and it must be invaluable to the young workman** who distrusts his experience in regard to escapements, etc.  
RACINE, Wis., July 11, 1884.  
J. WATTS, Watchmaker and Jeweler.

Enclosed please find postal note for \$1.25 in payment of your Hair Spring Stud Index. Value of time saved by its use in a **single month** would more than pay its cost.  
SOUTH BEND, Ind., June 27, 1884.  
HIGHT & FAIRFIELD, Jewelers.

Please find enclosed P. O. order for \$1.25 for your Hair Spring Stud Index. I think your tool very practical and one which has been long needed.  
WELLINGTON, Kan., May 31, 1884.  
E. L. ROSER, Watchmaker and Jeweler.

Enclosed you will find postal note for \$1.25, amount for Hair Spring Stud Index. Your Hair Spring Stud Index is immense. I am glad you sent it. I would not take twenty times the amount of its cost and be compelled to do without one. It saves so much time and trouble, every watchmaker in the land ought to have one.  
THORNTOWN, Ind., June 27, 1884.

Your Hair Spring Stud Index received. You ask me to return it if not suitable. Well, I guess not. I know when I have got a good thing and calculate to keep it. It is the handiest little tool on my bench. Enclosed find M. O. for \$1.25.  
MARQUETTE, Mich., June 30, 1884.  
O. N. RIDGWAY, Jeweler and Optician.

Enclosed please find order for \$1.25 due for Hair Spring Stud Index. It is a very handy tool—one that every jeweler ought to have.  
LENA, Ill., July 1, 1884.  
A. P. PARSONS & Co., Watchmakers and Jewelers.

We think your Hair Spring Stud Index a useful tool.  
WALTHAM, Mass., June 6, 1884.  
AMERICAN WATCH TOOL CO., Per Webster.

I received your Hair Spring Stud Index and will say that I think it a very useful tool. Enclosed please find Postal note for same.  
ELKO, Nev., June 17, 1884.  
N. B. NYE, Watchmaker and Jeweler.

Enclosed find \$1.25 to pay for Hair Spring Stud Index. I am well pleased with the same.  
FORT ATKINSON, Wis., June 3, 1884.  
C. B. TOUSLEY, Watchmaker for the trade.

Enclosed find \$1.25 for your Hair Spring Stud Index received. Am much pleased with it.  
TECUMSEH, Neb., June 10, 1884.  
Wm. CONRAD, Jeweler.

For sale by all leading Jobbers. **Price, \$1.25.** Sent by mail on receipt of price, or address the patentees and manufacturers,

**JOS. P. WATHIER & CO.,**  
WATCHMAKERS FOR THE TRADE, 178 WEST MADISON ST., CHICAGO, ILL.



No. I.

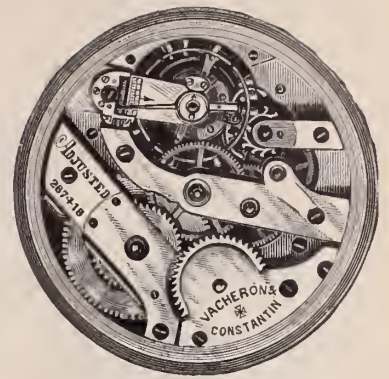

No. VIII.

ESTABLISHED 1810.

WATCH MANUFACTORY

OF

# VACHERON & CONSTANTIN, GENEVA.

TRADE MARK.



All these Celebrated Movements are made interchangeable, and to fit 14 and 18 Size Waltham and 16, 18 and 6 Size Elgin Cases.

TRADE MARK.



Also a Complete Assortment of Ladies' 12, 13 and 14 line Open Face and Hunting Watches.

Chronographs, Split Seconds, Minute and Five Minute Repeaters, in stock and made to order.

**CHAS. LEO ABRY,**

Sole Agent for United States and Canada,

**63 Nassau St., New York.**

P. O. Box 611.

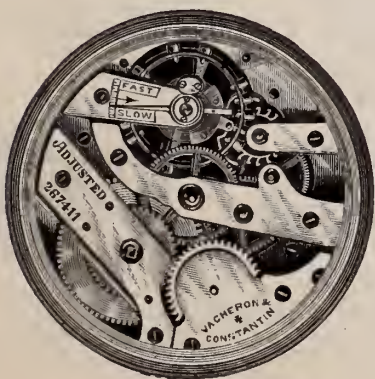

No. IX.

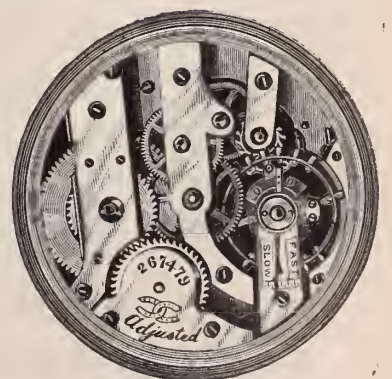

HORSE SHOE.

# The American Pebble Spectacles & Eye-Glasses

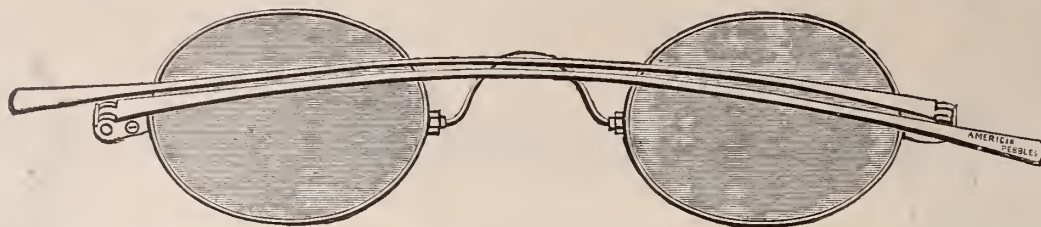

**The Most Popular and Easy Selling Optical Goods ever introduced.**

Agents wanted in every town and city to handle these goods, to whom we will give the control and offer special inducements. For all information apply to

**AMERICAN PEBBLE SPECTACLE CO., 66 Nassau Street, N. Y.**

NUREMBERG

1885.

Under the Patronage of H. M. King Louis II. of Bavaria.

## GREAT INTERNATIONAL EXHIBITION OF METAL WORK.

An International Competition will be opened for the design of the Exhibition Poster. Particulars of the Exhibition and Competition may be obtained from the "Bayrisches Gewerbemuseum," Nuremberg.

## "HELIOLA."

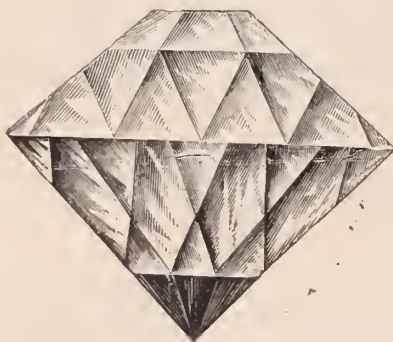

*We call the attention of the Trade to our celebrated Failed Stone, the "HELIOLA." These Stones have been used by first-class manufacturers for over a year and are the best in the market.*

*Ask your Jobber or Manufacturer for the "HELIOLA."*

*Respectfully,*

**L. & M. KAHN,**  
10 Maiden Lane, New York.

## R. HENRICH,

35 MAIDEN LANE,

NEW YORK.

**Manufacturing Jeweler.**

SPECIALTY:

**SEAL AND STONE RINGS.**

AND PATENTEE OF THE CELEBRATED SELF-SIZING AND ACME INITIAL RINGS.

Patented March 20, '83 and February 19, '84.

INITIAL RINGS made with and without the *Self-Sizing Attachment*.

I have introduced as a Novelty for this season the Ladies' Acme Changeable Initial Ring, (Pat. February 19, '84). The Trade will appreciate this new Ring, as it supplies a long-felt want.

**FOR SALE BY ALL JOBBERS.**



OPEN.



CLOSED.



# SOMETHING NEW!

## The Giles' Patent Anti-Magnetic Shield

NOW READY FOR THE MARKET.



The application of Anti-Magnetic Shields to pocket timepieces promises to be of very great importance to horologists and watchmakers; it will render operative the fine adjustments and mechanisms which hitherto have been made almost nil and inoperative on account of their susceptibility to the all-pervading magnetic influences. The advantages of magnetic-proof watches are many and very important.

- 1st. Protection against personal magnetism.
- 2d. Protection against electric currents which induce magnetism—magnetic belts and other personal electric appliances.
- 3d. Protection against magnetism caused by dynamo-machines, electric wires, the multiplied electric and magnetic devices of the present day, which places any one in daily danger of coming within their influence and having their watches affected thereby.
- 4th. A protection for railroad men, who are constantly under the influence of electricity and magnetism caused by the moving train.
- 5th. A protection for machinists, who are brought under the magnetic influence caused by the running machinery, belts, etc.
- 6th. Protection for breaking mainsprings caused by the so-called electric storms, or magnetic influences of the atmosphere.
- 7th. A dust-proof case keeps the watch in much better order, the oil fresh and clean, thereby reducing the friction, giving better time, and rendering the watch more durable.



SEND FOR DESCRIPTIVE CIRCULAR.

GILES, BRO. & CO., CHICAGO.

# THE HARTFORD SILVER PLATE COMPANY,

HARTFORD, CONN.,

## OFFER

New and Especially Desirable Patterns for the present season, both in Hollow and Flat Ware.

Our aim is to make only goods of the Highest Grade, both as to Design and Quality.

Buyers will find our wares such as they can recommend with confidence.

SALESROOMS AT

52 Park Place, New York,  
537 Market Street, San Francisco,  
And Hartford, Conn.,

Where all Communications should be Addressed.



No. 1263. TILTER.

Damascene Chased and Gold Lined, - - \$38.50

TO THE LEADING JEWELERS.

MILLER'S REVOLVING WATCH SIGNS.

We wish to call your attention to our **BIG WATCH SIGNS**, which are made of Galvanized Iron and Zinc, Painted and Gilded with the best Gold Leaf, and **Warranted in every respect.** We make them all sizes, the largest being 66 inches in diameter and 100 inches high; weight 86 pounds. They are so constructed as to revolve on a post, or swing on a rod from the building, and not blow down. These Watches are patented, and as we sell **only one of the large size in a town**, any enterprising jeweler can appreciate the advantage of an advertisement that his competitors cannot imitate. They are made in perfect proportions to a watch, being symmetrical and perfectly elegant, and the most attractive sign ever put up. To see it is to buy it. We never fail to sell it where we can show it to advantage. We call your attention to the importance of immediate thought and action, as your neighbor may order one ahead of you. Address all communications to

ED. C. MILLER, Bellefontaine, Ohio.



S. C. JACKSON,  
180 BROADWAY, N. Y.



NEW STYLES OF  
**FINE CASES,**  
(And also a Medium Quality on Hand)  
For Jewelry, Watches, Silverware, Etc.  
Specialty of Fine Rosewood, &c. Trays.  
Embroideries, Paintings, &c. from China, Japan, etc.

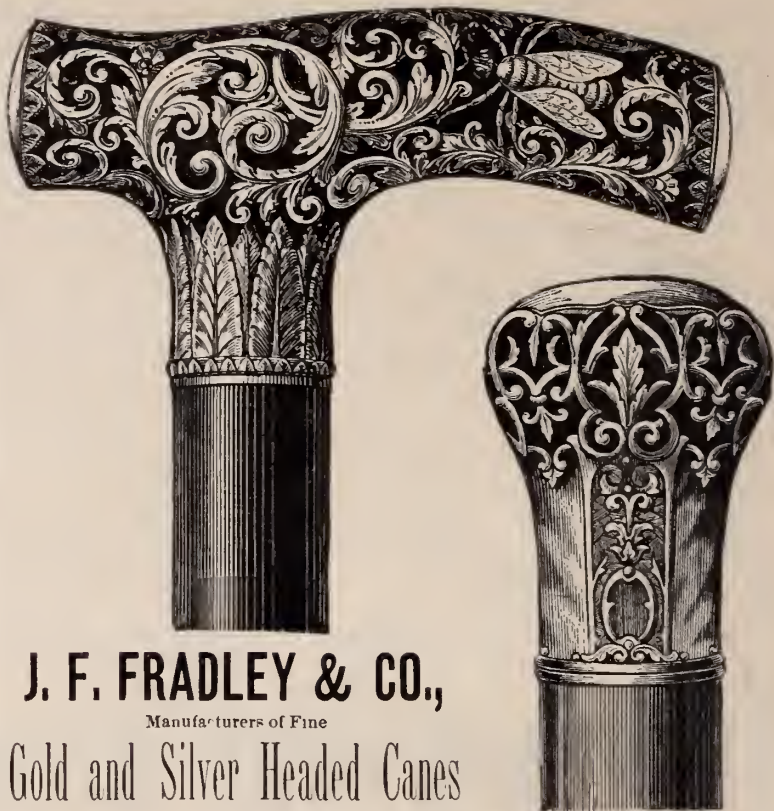

**J. F. FRADLEY & CO.,**  
Manufacturers of Fine  
Gold and Silver Headed Canes  
AND SPECIALTIES.  
**23 JOHN STREET, NEW YORK.**

Designs furnished for Presentation Canes. Our New Illustrated Catalogues containing many new designs will be ready August 1st and will be sent upon application.  
Special Inducements to the Jobbing Trade.

SEND FOR CIRCULAR.

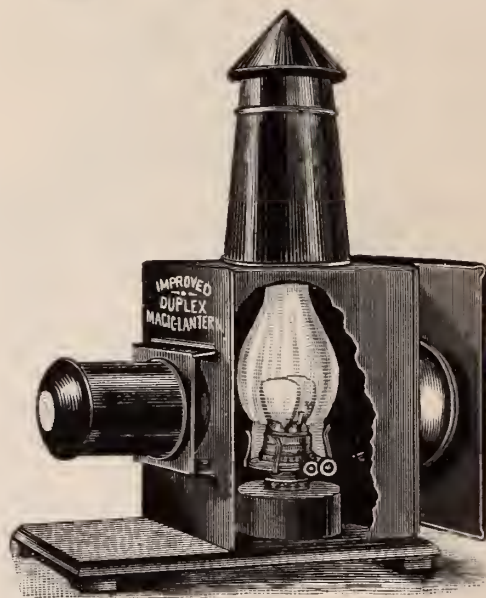

SEND FOR CIRCULAR.

**New Improved Duplex Magic Lantern,**  
MANUFACTURED BY  
**JOHN SCHEIDIG & CO.**  
IMPORTERS AND MANUFACTURERS OF  
Spectacles, Eye-Glasses, Opera, Field and Marine Glasses,  
**TELESCOPES, MAGIC LANTERNS,**  
AND OTHER OPTICAL AND MATHEMATICAL INSTRUMENTS,  
43 MAIDEN LANE,  
NEW YORK.

**SPECIAL NOTICES.**

**Notices under this Heading, not to exceed Six Lines, \$1.00 each insertion.**

Advertisers having letters addressed in care of this office, must inclose postage for answers forwarded.

**WANTED**—A situation by a first-class watchmaker; New York City preferred. Address J. W. S., care Jewelers' Circular.

**WANTED**—Curiosities in horology. Anything really curious, auclent or modern. Address with full description and price, Lock Box B., Waterbury, Conn.

**STEM-WINDING** wheels of all kinds, in stock and to order. Escape wheels, duplex, cylinder and chronometer. Chronograph stars. S. Millard, No. 6 John St., N. Y.

**FOR SALE**—A small jewelry store in the vicinity of New York. Stock and fixtures worth about \$1,000; may be reduced if desired. Address Th. S., care Jewelers' Circular.

**SITUATION** wanted by a watchmaker of 9 years' experience; can furnish first-class references; can accept at once. L. A. D., care Chapman, Jeweler, Oneonta, N. Y.

**WATCH** and jewelry repairing in all its branches. English watches altered from key to stem-winding; new principle; satisfaction guaranteed. S. Millard, No. 6 John St., N. Y.

**WANTED**—A good watchmaker and jeweler; to the right man a permanent situation will be given; must have good recommendations. Address F. E. Capewell, Tontingon, Conn.

**CANADIAN** watchmaker and jewelry jobber, and who is also a good salesman, has had 14 years' experience, desires a situation; best of references. Address Box 46, Galt, Ont., Canada.

**FOR SALE**—A jewelry store in the thriving village of Little Falls, N. Y. A good chance for a young man of energy and small capital. For particulars, address I. H. H. Vosburgh, Little Falls, N. Y.

**SITUATION WANTED**—After Jan. 1st by a fully competent watchmaker, who has had sixteen years' experience with the better class of trade. Address, stating salary, etc., A. J. Rowles, care Circular.

**WANTED**—A first-class watchmaker and engraver with the very best of reference to go to Pensacola, Fla. A single and middle aged man preferred; state price, etc. Address J. I. Stephens, Pensacola, Fla.

**WANTED**—The addresses of all traveling dealers in watch materials, etc., to introduce an easily selling and well paying novelty. Communications will oblige H. B., care Editor Jewelers' Circular, 42 Nassau St., N. Y.

**WANTED**—A situation to travel for a first-class jewelry house (watches and diamonds preferred), by a salesman well acquainted with the trade, gained by an experience of sixteen years. Address B., care Jewelers' Circular.

**MOSELEY & CO.**, Elgin, Ill., manufacturers of the "Moseley" Lathe, with full line of fixtures and attachments. Designed especially for the watchmaker and repairer. Combining accuracy, durability, convenience and style.

**A TRAVELING** salesman, 30 years of age, single, steady habits, 15 years' experience in the trade, will be open for an engagement with a watch and jewelry house or manufacturer after Jan. 1st. Address D. E. G., care Jewelers' Circular.

**TRAVELING** salesman wants position Jan. 1st; young and enterprising; has had 3 years' experience through middle and eastern States. Still with old concern, but would like to make new arrangements for the coming year. C. H. F., Jr., care Jewelers' Circular.

**WANTED**—Situation by a young man 27 years old, practical watchmaker, 5 years' experience. Has been in business for himself; would take charge and run business for small remuneration; prefer country town. Address Geo. Howard, 85 W. Railroad St., Syracuse, N. Y.

**WATCHMAKERS TAKE NOTICE**—Do not fail to send your address and get full particulars of my valuable discovery. Every watchmaker that has tried it is well satisfied. It saves time, money and labor. Address J. B. Dale, Box 656, Edwardsville, Madison Co. Ills.

**WANTED**—A practical jeweler to buy out a \$1,500 stock of jewelry in a new and flourishing town of about 1,000 inhabitants, situated at the junction of the N. Y. P. & O. and W. & L. E. R. Rds; no competition; terms very liberal. Address R. A. Bassett, Creston, Wayne Co., O.

**A TRAVELER** having a fair trade in stone rings in the east and west, and being with a house at present the sixth year, wishes a situation, with a specialty of rings, from 1st of January, 1885. Good references given. Please address J. H. Fink, care of S. Fink, 38 Eldridge St., New York.

**WANTED**—Situation by a watchmaker of 12 years' experience. Can do jewelry jobbing, and script and old English engraving. Have American lathe and fine set of tools; understand all fine and complicated watches; can give first-class references. Address M., care Jewelers' Circular.

**WANTED**—Watchmaker who can invest \$1,000 to \$1,500, to buy out a well established retail jewelry store in a good city in northeast part of Ohio. Present stock about \$5,000, but can be reduced to suit purchaser. Good reason given for selling out. Address Enterprise, care Jewelers' Circular.

**GEORGE E. WILKINS**, manufacturer and importer of cutters for watchmakers' use, stem-winding cutters of all the different forms, rounding up cutters of the finest quality, also ratchet cutters. A large stock of second hand and new marine chronometers. No. 21 South Salina street, Syracuse, N. Y.

**FOR SALE**—First-class jewelry store in town of 8,000 population and thickly settled country around. Leading store of the place in stock and trade. Will invoice stock and fixtures about \$5,000. Reasons for selling am not a practical jeweler and want to move west. Address C. C., care Jewelers' Circular.

**WANTED**—The address of some gentleman of means who would be willing to loan me \$2,000 or \$2,500 on the benefit (\$5,000) of my membership in the Jewelers' League. Or, I will make an outright sale of the same for a sum sufficient to start myself in a small business. Address Loan, care Jewelers' Circular.

**WANTED**—1st February or March, 1885, situation as watchmaker and engraver; 12 years' experience; can do all kinds of watch work; engrave monograms, script and Old English; first-class salesman and understands the business throughout; sober and industrious; first-class reference. Address K. H., care Jewelers' Circular.

**FOR SALE**—Old established jewelry business in town of 12,000 in eastern Pennsylvania. Stock small and clean; part cash and good security required for balance; fine chance for young man; death of owner only reason for selling. For particulars, apply to Mrs. Jos. G. Kelly, Lebanon, Pa., or McCarty & Hurlburt, 131 N. Second St., Philadelphia.

**TUBING** of every description drawn to order at short notice. Gold pen, pen and pencil cases, novelties, tooth picks, at lower prices than can be purchased elsewhere. Sample line sent on approval to approved parties. Gold pens re-pointed, repaired, exchanged. Ray Manufacturing Company, safes, room and factories, 94 & 96 Nassau St. and 129, 131 and 133 Fulton St., New York.

**A TRAVELING** salesman now engaged in selling jewelry for an eastern house wishes to make a change Jan. 1st. Have been with present house three years; am acquainted with the trade and have traveled in 17 States. Would accept situation with a first-class silverware company, clock company or jewelry house; manufacturer preferred. Address "Traveler," care Jewelers' Circular.

**FOR SALE**—Stock, fixtures, good will and lease, or will dispose of good will and lease of a jewelry store doing a large and profitable business. The present owner desires to make a change of climate on account of bad health; the store caters largely to country trade; passengers to boats and ferries pass the door constantly all days. We employ three men for watch work. Address X. Y. Z., care Jewelers' Circular.

**TO THE TRADE**—I make a specialty of supplying the Trade with stones for jobbing purposes. Parties having jewelry out of which the stones have been lost, sending their orders by mail or express, will have them promptly attended to. A large stock of cameos, pearls, turquoise, garnets, amethysts, doublets, foil backs, white and colored imitation stones on hand. All kinds of setting done for the Trade. W. Archibald, 73 Nassau street, New York.

**FOR SALE**—A first-class jewelry store in one of the best towns of Central Pennsylvania of over 2,000 inhabitants. Great manufacturing town and a large country trade; has a good run of bench work and doing a general good business. Store is located the best in town; plate glass front and finely furnished inside; dwelling under same roof; stock of fixtures will inventory about \$3,000; will sell to suit buyer, either the whole or part, or fixtures and material without stock. A long lease can be had for store room alone or for house and store room. Good reasons for selling. For particulars, address Boston Jackson, Watsonown, Pa.

**FOR SALE**—A good paying jewelry business in a good live city in middle Nebraska. 3,500 inhabitants, 4 good railroads, county seat, and surrounded by a good farming country. Present stock about \$10,000, can be reduced to suit purchaser. A good run of work, enough for 2 men; good prices for every thing, competition light, rent low, and the best location in the city; good, nice and clean stock, all staple. There was never a chance better than this for a man who wants to make money in the jewelry business, it will double discount any big city business with the same capital invested. Good reason given for selling out. For other information write to The Leading Jeweler, P. O. Box 99, Columbus, Nebraska. A man who has not got \$4,000 to \$5,000 need not reply.

**BUYERS' DIRECTORY.****NEW YORK.****Assayers and Sweep Smelters.**

**Wundoehl, H.**—Gold and Silver Refiner, Assayer and Sweep Smelter. 21 John Street, N. Y.

**Badges and Medals.**

**Frick, John & Co.**—Makers of Medals and Badges of all kinds. Also Manufacturers of Jewelry. Dealers in Fine Rolled Plated Goods, etc. 23 Maiden Lane, N. Y.

**Stockwell & Newman**—19 John Street. Manufacturers of Badges, Medals and Presentation Pieces in Gold and Silver. Also Jewelry and Mounters of Diamonds. Designs supplied,

**Band Rings.**

**Knapp, Charles**, 41 Maiden Lane, N. Y. Specialty: Superior Band Rings, also Ring Shanks & Heads for Seal and Diamond Rings.

**Black Onyx Jewelry.**

**Cox & Sedgwick**—Manufacturers of Black Onyx Jewelry, No. 26 John St. New York.

**Lawson, Samuel**—No. 13 John Street. Manufacturer of Black Onyx Jewelry. Coral repaired for the trade. Goods sent on approval to responsible dealers.

**Woglom & Miller**—Manufacturers of (exclusively) Black Onyx Jewelry, 32 & 34 John St., N. Y.

**Blue Enameled Lockets.**

**Bissinger, Philip & Co.**—Importers of Diamonds, Pearls and Precious Stones. Agent for the Bohemian Garnet Goods. Blue Enameled Lockets and Coral Goods. 22 John St., N. Y.

**Emrich, I.**—Importer of Blue Enameled Lockets, Ear Drops and all kinds of Enameled Jewelry; also Enamel for Manufacturing purposes. 66 Nassau St., N. Y.

**Bohemian Garnet Jewelry.**

**Bissinger, Philip & Co.**—Importers of Diamonds, Pearls and Precious Stones. Sole Agent for the Bohemian Garnet Jewelry. Blue Enameled Lockets and Coral Goods. 22 John St.

**Emrich, I.**—Importer of Half Pearls and Bohemian Garnet Jewelry. Designs made to order in our European Factory at moderate prices. 66 Nassau St., N. Y.

**Clock Companies.**

**Ansonia Clock Co.**—Manufacturers of every description of Clocks. 11 to 21 Cliff street, New York.

**E. Howard Watch and Clock Co.**—No. 29 Maiden Lane, New York, and 114 Tremont St., Boston.

**Kroeber, F.**—Manufacturer and Dealer in American and French Clocks, No. 14 Cortlandt Street.

**Le Boutillier & Co.**—Importers and Jobbers in French Marble Clocks. 31 and 33 West 23d Street, N. Y.

**New Haven Clock Co.**—16 and 18 Park Place, N. Y.

**Seth Thomas Clock Co.**—20 Murray Street, N. Y.

**Waterbury Clock Co.**—Manufacturers, No. 10 Courtlandt St., N. Y. and No. 63 Washington St., Chicago, Ills.

**Welch, E. N., Manufacturing Co.**—Manufacturers of American Clocks. No. 6 Warren St.

**Wm. L. Gilbert Clock Co.**—No. 6 Murray Street, Manufacturers of Clocks. Factories, Winsted, Conn.

**Cameo Cutters, Etc.**

**Peiter, Theodore**—Cameo and Intaglio Engraver. Patentee of the Cameo-Intaglio. No. 3 Maiden Lane, New York.

**Charms & Gold Watch Keys.**

**Rupp & Held**—Manufacturing Jewelers, Charms and Gold Watch Keys, with French and English Rachets, a specialty. 15 John St., N. Y.

**Chasers and Engravers.**

**Deming & Lincoln**—Chasers and Engravers. Fine Engraving of Plated Ware a Specialty. Chasing in all its branches. Moulds made for the trade. 73 Nassau Street, N. Y.

**Crucibles.**

**Berge, J. & H.**—Established 1850. Importers of Sand Crucibles, Covers, Chemical Porcelain, Glassware, and Jewelers' and Assayers' Supplies. 95 John Street, N. Y.

**Diamond Brokers.**

**Anderson, Otis**—Diamond Merchant and Broker, always ready to pay cash for bargains in Diamonds and Precious Stones, 4 & 6 John Street, N. Y.

**Friend S. & Son**—Brokers and dealers in Diamonds 33 John Street, cor. Nassau St. New York.

**Herbert, R. J.**—Diamond Broker and Dealer, 26 Maiden Lane.

**Diamond Importers.**

- Anrich, E. L.**—Diamonds, 182 and 184 Broadway, cor. John St. N. Y. Cutting Establishment, 133 Water St.
- Bernhard, A. & Co.**—Importers of Diamonds and Manufacturers of First-class Diamond Jewelry, Diamond Settings for Manufacturing Jewelers. Catalogue of Designs for the Trade free of charge. No. 2 Maiden Lane, New York.
- Bissinger, Philip & Co.**—Importers of Diamonds, Pearls and Precious Stones. Agent for the Bohemian Garnet Goods. Blue Enameled Lockets and Coral Goods. No. 22 John St., N. Y.
- Bruhl, D. & M.**—Established in 1848. 14 Maiden Lane, N. Y.; 111 Broad Street, Providence, R. I.; 14 Rue Bleue, Paris.
- Brunswick, S. & Co.**—Importers of Diamonds. 17 Maiden Lane, New York. Paris, Rue Lafayette. Amsterdam, Damsiraat.
- Citroen, L. B., & Co.**—Diamonds. 21 John St., N. Y. Cutting Works, 57 & 61 Rapenburgerstraat, Amsterdam. House in Paris, 53 Rue de Chateaudun.
- Faulkenau, Oppenheimer & Co.**—Manufacturers. Diamonds and Diamond Jewelry. 40 Maiden Lane, N. Y.
- Fera, Henry**—Importer of Diamonds, and Manufacturer of Fine Diamond Jewelry. 4 & 6 John Street, New York. Amsterdam, Holland, 23 Loojersgracht.
- Fox, M. & Co.**—Importers of Diamonds, Rubies, Sapphires and Fancy Gems. No. 1 Maiden Lane, New York
- Hedges, Wm. S. & Co.**—Importers of Diamonds. No. 170 Broadway, corner Maiden Lane.
- Henle Brothers**—Importers of and Wholesale Dealers in Diamonds only. No. 16 Maiden Lane, N. Y. Paris, 20 Rue Laffitte.
- Hessels, Anthony**—Importer and Dealer in all kinds of Precious Stones. Diamond Cutters and Polishers. 45 John Street, N. Y.
- Kuhn, Doerflinger, & Co.**—Manufacturing Jewelers and Importers of Diamonds, 18 John street, New York
- Leberthon, L. M.**—Importer of Diamonds and Manufacturer of Fine Jewelry. 14 John Street, N. Y.
- Miller Bros.**—Importers of Diamonds and Manufacturers of Fine Diamond Jewelry and Mountings.
- Mulford & Bonnet**—Diamond Importers, No. 21 Maiden Lane, N. Y. City.
- Neresheimer, E. Aug. & Co.**—Importer of Diamonds. No. 21 Maiden Lane, New York
- Randel, Baremore & Billings**—Importers of Diamonds, corner Maiden Lane and Nassau St.
- Saril, S.**—Importer of Diamonds, 182 Broadway, N. Y. Branch of Vve. H. A. Marchand & Frères, 47 Rue Le Peletier, Paris.
- Saunders & Ives.**—Importers of Diamonds and other Precious Stones. No. 26 Maiden Lane.
- Smith, Alfred H. & Co.**—Importers of Diamonds, No. 182 Broadway.
- Strauss, Jacob**—Importer of Diamonds and Dealer in Diamond Jewelry. 25 John Street.
- Tannenbaum, L. & Co.**—Importers of Diamonds and Precious Stones. Steam Lapidary Works. Oriental Stones Cut and Polished a specialty. 65 Nassau St., N. Y.
- Taylor & Brother.**—Importers of Diamonds and Diamond Jewelry. 860 Broadway.
- Wickham, D. H. & Co.**—Importer of Diamonds. No. 31 Holborn Viaduct, London, 24 Maiden Lane, New York.
- Wolff, G. A.**—Importer of Diamonds, Rubies, Sapphires, Pearls, and other Precious Stones, 65 Maiden Lane, New York. 12 Rue de Chateaudun, Paris.

**Diamond Jewelry.**

- Baldwin, Sexton & Peterson**—Importers of Diamonds and Manufacturers of Diamond Jewelry, 602 and 604 Broadway, N. Y.
- Bornemann, Louis.**—Importer of Diamonds and Manufacturer of Rich Diamond Jewelry, 19 John Street, New York.
- Chalumeau, D.**—Diamond Jeweler and Manufacturer of Mountings. Novelties and Artistic Jewelry. No. 3 Maiden Lane, New York.
- Goldsmith, Ingomar & Co.**—Manufacturers of Diamond Mountings and Diamond Jewelry, 61 Nassau Street, New York.

- Goldsmith & Co.**—Manufacturers of Fine Diamond Mountings and Diamond Jewelry. Lace Pins, Ear Rings and Rings a specialty. 49 Maiden Lane, N. Y.
- Hartje, G. & F.**—Manufacturers of Diamond and Fine Jewelry, 39 Union Square, N. Y.
- Haug, John**—Manufacturer of Fine Diamond Mountings, etc. No. 130 Fulton St., N. Y.
- Heller & Bardel.**—Manufacturers of Diamond and Pearl Jewelry, and Dealers in Diamonds, Pearls, &c. 13 John Street.
- Jeanne Brothers.**—Manufacturers of Diamond Mountings & Rich Jewelry. 1 Maiden Lane.
- Lacroix & Verpillier.**—Manufacturers of Fine Gold Jewelry. Diamonds a specialty. 173 Broadway, N. Y.
- Luthy, A. & Co.**—Manufacturers of Fine Diamond Mountings, Lace Pins, Ear Rings, Rings, Knife Edge Bracelets, Hair Ornaments, etc., a Specialty. 35 Ann Street, corner Nassau Street, N. Y.
- Mitchell, Noah**—Manufacturer of Diamond Jewelry and Diamond Mountings. 52 Maiden Lane, New York.
- Nissen, Ludwig & Co.**—Dealers in Diamonds and Manufacturers of Diamond Mountings. No. 51 Nassau Street, New York, near Maiden Lane.
- Rosswog, C. & Son**—Manufacturers of Rich Diamond Goods. Nos. 5 and 7 Maiden Lane, N. Y.
- Stern & Karutz**—Manufacturers of Fine Diamond Mountings. Lace Pins, Ear Rings, Rings, Knife Edge Bracelets a Specialty. Orders by mail promptly attended to. 130 Fulton Street, Room 11, first floor, New York.
- Voelker, C. T.**—Manufacturer of 18-k. Diamond Mountings, Diamond Jewelry and Roller Chain Bracelets. 15 Maiden Lane, New York.
- Waterman & Lehmann.**—Manufacturing Jewelers and Dealers in Diamonds. Diamond Work, and Fine fancy Rings a specialty, any piece of single work made to order. 37 Maiden Lane, N. Y.
- Wienhold, J.**—Manufacturer of Fine Jewelry. Diamond Mountings a specialty. 24 John Street.

**Diamond Cutters.**

- Levy, Herman.**—Importer, Cutter and Polisher of Diamonds. 105 Fulton Street, New York.
- Mendes, D. De S.**—Diamond Cutter and Polisher, 113 Nassau St., N. Y. Re-cutting, Repairing and Matching a Specialty.

**Enameled Clock Dials and Figures.**

- Caeser Bros.**—Manufacturers of Enameled Clock Dials, also letters and numbers for signs. 230 and 232 East 25th Street, New York.

**Enamelers, Etc.**

- Nutt, J. D.**—Enameler on Gold, Silver, and Copper. Linen finished Buttons and Studs. Enameling in colors. 32 and 34 John Street, New York.
- Orr, J. C.**—Enameler on Fine Jewelry. Enameled in Colors. Linen Finished Buttons and Studs. Band Bracelets. No. 75 Nassau Street, N. Y.

**Engravers—Stone Seal, Etc.**

- Fackner, Edward**—Carver, Engraver and Chaser on Jewelry and Pencil Cases, lettering, &c., 19 John Street.
- Holland & Gosling**—Stone Seal Engravers. Precious Stones inlaid and encrusted with Diamonds. No. 176 Broadway, New York, (fifth floor per elevator). Cameos cut and repaired.
- Knapp, Chas.** Engraver, Die Sinker & Stamper for Jewelry purposes. Ring Shanks & superior Band rings, 41 Maiden Lane, N. Y.
- Park, Wm.**—The Stone Seal Engraver. Arms, Crests, Monograms, etc., engraved on precious stones, 26 John Street, New York.
- Weston, James F.**—Stone Seal Engraver and incruiter of Precious Stones. Coats of Arms, Masonic, Odd Fellows, and other devices engraved. 32 John Street.

**Fancy Goods, Clocks, Bronzes, Etc.**

- Hinrichs, C. F. A.**—Importer of Fancy Goods, Glassware, China, Clocks, Bronzes, etc. 31 Park Place.
- Le Boutillier & Co.**—Importers of Fancy Goods, Clocks, Bronzes, &c., 33 West 23d Street.

**Straus, L. & Sons**—Importers of Potteries, Faïences, Bisque Figures. and Rich Fancy Goods especially adapted for the Jewelry Trade. 40, 42 and 44 Warren Street, New York.

**Taylor & Bro.**—Importers of French Clocks, Bronzes, etc. 676 Broadway, N. Y.

**Young, J. M. & Co.**—Importers of Fine Parian, Lava, and Bisque Statuary, Bohemian, German and English Fancy Goods, 37 & 39 Murray St., New York.

**Gold and Silver Cane Heads.**

- Cuppia, L. A.**—Importer of Filigree Jewelry and Manufacturer of Silver and Gold Cane Heads and Novelties in Silver and Gold Jewelry. 19 Union Square, N. Y.
- Locklin, F. P. & Ero.**—Manufacturers of Gold and Silver Headed Canes. 142 Fulton Street, N. Y.
- Simons, Bro. & Co.**—Manufacturers of Gold Headed Canes. 611 and 613 Sansom street, Philadelphia.
- Smith, Rest Fenner & Co.**—No. 701 Broadway, Makers of Fine Gold and Silver Headed Canes.

**Gold and Silver Plating, Etc.**

- Bantle, A.**—Gold, Silver and Electro-Plating, 130 Fulton and 89 Nassau Streets, cor. Fulton Street, (Room 36,) N. Y. Watch Case Polishing.
- Jehandheur, F.**—Gold and Silver Electro Plater and Fire Gilder. Coloring Etruscan and Gold Jewelry a Specialty. 125 Fulton Street.
- Klees & Magrath**—Gold and Silver Electro-Platers. Coloring Etruscan and Gold Jewelry a Specialty. 89 Nassau Street, New York.

**Gold Chains, Etc.**

- Beck, J. & Son,** Manufacturers of Fine Gold Chains and Chain Bracelets, 10 Liberty Place, near Maiden Lane, N. Y.
- Carter, Sloan & Co.**—Manufacturers of Fine Gold Chain, 15 Maiden Lane, New York.
- Edge, W. C. & Co.**—Manufacturers of the Celebrated Woven Fabric Gold Chain, No. 15 John Street.
- Kaufmann Bros.**—Manufacturers of Gold Chains, and Chain Bracelets, 12 First Street; Factory, 331 and 333 Bowery, N. Y.
- Kohn, Alois & Co.**—Manufacturers of Gold Chains. 9 Maiden Lane, N. Y.
- Saxton, Smith & Co.**—Manufacturers of Fine Gold Chain, No. 14 John Street, N. Y.
- Schlag, Chas.**—(Late Nordt & Schlag), Manufacturer of Gold Chains, Chain Bracelets and Fine Jewelry. 177 Broadway, New York. All kinds of Jobbing promptly attended to.
- Smith, W. & Co.**—Manufacturers of Gold and Silver Chains, Jewelry, etc. No. 25 Maiden Lane, N. Y.

**Gold Pens, Etc.**

- Aikin, Lambert & Co.**—Manufacturers of Choice Gold Pens, Cases, Holders, Toothpicks, etc., 23 Maiden Lane, N. Y.
- Faber, Eberhard.**—Manufacturer of 16-karat Gold Pens and Pencil Cases. Nos. 718 and 720 Broadway, N. Y.
- Fairchild, Leroy C. & Co.**—No. 10 Maiden Lane, New York. Manufacturers of Gold Pens, Pencils, etc.
- Fairchild, Leroy W.**—Manufacturer of Gold Pens, Pencil Cases, Tooth Picks and Novelties in Charms. No. 18 John St., N. Y.
- Foley, John**—Manufacturer of Fine Gold Pens, Pencils and Charms. 2 Astor House, N. Y.
- Hicks, W. S.**—Established 1848. Manufacturer of Fine Gold Pens, Pencil Cases, Tooth Picks, and Charm Novelties of every description. No. 20 Maiden Lane.
- Johnson, E. S. & Co.**—Manufacturers of Gold Pens, Pen Holders and Pencils. Cor. Maiden Lane and Nassau Street, New York.
- Smith, H. M. & Co.**—Manufacturers of Gold Pens and Holders, Tooth Picks, Pencils, etc. Sole Manufacturers of Sprague's Patent Gold Fountain Pen. Importers of Nickel and Silver Watches. 173 Broadway, New York.

**Gold Rings.**

- Barnet Bros.**—Manufacturers of Stone and Seal Rings, 15 John Street, New York. Factory, Newark, N. J.

**Bowden, J. B. & Co.**—Manufacturing Jeweler.—Solid Gold Rings a specialty, 1 Maiden Lane.

**Cable, Geo. W.**—Manufacturing Jeweler. Plain and Band Rings a Specialty. No. 52 Maiden Lane, N. Y.

**Dattelbaum & Friedman**—Manufacturers of Fine Cameo and Seal Rings, all kinds of Fancy Rings and Diamond Mountings. 10 Maiden Lane.

**Ely, W. H.**—Manufacturer of Solid Gold Rings of every description. No. 58 Nassau Street.

**Engelfried, Braun & Weidmann**—Manufacturing Jewelers, 128 Fulton Street corner Nassau, New York. Commercial Building, room 31. Rings a specialty.

**Henrich, R.**—No. 35 Maiden Lane, Manufacturer of Gold Rings; also Patentee and Manufacturer of the Celebrated Self-Sizing Ring

**Hutchison & Huestis**—Makers of Solid Gold Rings. Quality guaranteed. For the Jobbing Trade only. 196 Broadway, N. Y.

**Kroll, H.**—Manufacturing Jeweler. 78 Nassau Street, New York. Specialty: Solid Gold Stone Rings. All kinds of Fine Jewelry made to order, also Repairing for the Trade.

**Müller, H.**—111 Nassau St., N. Y., Manufacturer of Fancy and Seal Rings of every description. Plain Gold and Chased Band Rings in 10, 14 & 18 Kt.

**Ostby & Barton**—Manufacturers of Plain and Engraved Solid Gold Band Rings. Office, 176 Broadway, N. Y. Factory, 80 Clifford Street, Providence, R. I.

**Peckham, Wm. H.**—Manufacturers of Solid Gold Seamless Rings, and Fancy Embossed Rings, Patent Spectacles, Jewelry, etc. No. 4 Liberty Place N. Y.

**Radler, K.**—Manufacturing Jeweler. Gold Rings and Locketts a specialty. No. 179 Broadway, New York.

**Sauter, L.**—No. 1 Maiden Lane, New York, Manufacturer of Stone Rings of every description, as Diamond, Cameo, Onyx Turquoise, etc., Scarf Pins, Scarf Rings, Studs and Buttons.

**Shafer & Douglass.**—Manufacturers of all kinds of Seal, Stone, Turquoise, and fancy rings. No. 7 Maiden Lane, N. Y.

**Thuerner & Church**—Manufacturers of Fine Gold Rings. No. 9 Maiden Lane, N. Y.

#### Hair Jewelry.

**Moutoux, Wm. E. & Co.**—Manufacturers of Fine Hair Mountings in Gold. Grand catalogues for the trade. 81 Nassau St., Rooms 1 and 2. Finest work and lowest prices

**Sauter, L.**—Manufacturer of Fine Gold and Hair Jewelry and Device Work. Pattern Book sent on application. No. 1 Maiden Lane, N. Y.

**Schwencke O.**—Manufacturer of Fine Hair Jewelry Orders from the country promptly attended to. No. 43 Maiden Lane.

#### Initial and Monogram Jewelry.

**Miller Bros.**—Manufacturers of Sleeve Buttons, Studs, Collar Buttons, Lace Pins, Seals, Medallions, etc., Mounted with Old English, Block, Engraved, Rustic and Opalized Initials. Monograms to Order. 7 Maiden Lane.

#### Jewelry Cases, Fancy Boxes, Etc.

**American Morocco Case Co.**—7 & 9 Bond St., N. Y., make a specialty of Rich Jewelry, Silverware Cases and Improved Trays for Watches, Rings, &c. Patent Watch Blocks to fit all sizes.

**Braun, Chr. E.**—Manufacturer of Fine Jewelry Boxes and Trays for Show Cases and Trunks, No. 62 Chatham Street, New York. Trays for Show Cases and Trunks a Specialty.

**Bricka & Warmers**—Manufacturers of Morocco Cases for Cutlery, Silverware, Jewelry, etc. Sample Cards and Rolls. Cases in Rosewood, Black Walnut, etc. 52 Nassau Street, New York.

**Dennison Mfg Co.**—Manufacturers of Morocco, Plush and Velvet Jewelry and Silverware cases. New York, Boston, Philadelphia, Chicago, Cincinnati and St. Louis.

**Haensler, Chas. C.**—Manufacturer of Fine Morocco Cases for Jewelry and Silverware. Toilet Boxes, etc. Trays for Show Cases and Windows. 14 John Street, New York.

**Hebbard & Brother**—Manufacturers of Jewelry and Silver Ware Cases, and Fancy Wood Chests for Tea Sets and Flat Ware. 860 Broadway, New York.

**Jackson, S. C.**—Manufacturer of Fine Cases for Jewelry, Watches, Silverware, etc. 180 Broadway, N. Y.

**Kohn, Solomon**—Manufacturer of Fine Morocco Cases for Jewelry, Watches, etc. 43 Maiden Lane, New York.

**Lauten, Edw. A. & Co.**—No. 4 Great Jones St., Manufacturers of Fine Velvet, Brocade, Plush and Morocco Boxes, Patent Ring, Ear Ring and Gent's Scarf Pin Trays, Patent Watch and Bracelet Blocks, Window Decorations, etc.

**Loehr & Koerner**—Manufacturers of Morocco, Velvet, Satin, Jewelry, Watches and Silverware Cases, Jewel, Work Boxes, etc., Fancy Trays and Store Fittings to order. 96 Liberty St.

**New York Morocco Case Co.**—Cases for Jewelry, Watches, Silverware. Boxes and Trays for Jewelers' Travelers. Show Cases and Window Fittings. No. 69 Nassau Street, New York.

**Schwarz, N.**—Manufacturer of fine Cases for Jewelry and Silverware. 866 Broadway, New York.

**Welch & Miller**—169 Broadway. Manufacturers of fine Morocco, Velvet, Russia, Brocade and Plush Jewelry Cases. Trays of every description; Jeweler's Cotton and Twine.

**Wiggers & Froelick**—No. 60 Nassau street—Manufacturers of Cases for Jewelry, &c., of every description. Trays for Show-cases, Stands for Show-windows, etc.

#### Jewelers' Findings.

**Dennison Mfg Co.**—Paper Jewelry Boxes, cards, tags, pink and white cotton, etc. etc. New York, Boston, Chicago, Cincinnati, Philadelphia, St. Louis.

**Ettlinger, L., & Sons**—Makers of Cases and Paper Boxes of every description for Jewelers and Silversmiths. Fine Cases and Trays to order a specialty; also Cards, Tags, Cotton, Tissue Paper, &c. 80 Nassau St., N. Y.

**Lehmann, Ludwig.**—Manufacturer of Jewelers' Findings. 122 Fulton St., near Nassau, N. Y.

**Valer, S. & Co.**—Manufacturers and Dealers in Jewelers' Boxes, Tags, Cards, Paper and Findings. Trays a specialty. Fancy Ornaments for Show Windows. 66 Nassau street, New York.

#### Jewelry Manufacturers.

**Aikin, Lambert & Co.**—Manufacturers General stock of Reliable Jewelry, 23 Maiden Lane.

**Alling, Isaac A. & Co.**—Manufacturers of Fine Gold Jewelry. Specialties: Wire Bracelets, Bangles, American Lever Sleeve Buttons. Bryant Building, Nassau and Liberty Streets, N. Y. Factory, Newark, N. J.

**Baldwin, Sexton & Perterson**—Manufacturers of Rich Jewelry, 692 and 694 Broadway, N. Y.

**Ball, W. H. & Co.**—Manufacturers of Gold Jewelry. Bracelets and Bangles of all kinds a specialty. 9 John Street, N. Y.

**Bissinger, Philip & Co.**—Importers of Diamonds, Pearls and Precious Stones. Sole Agents for the Bohemian Garnet Jewelry, Blue Enameled Locketts and Coral Goods. 22 John St., N. Y.

**Bonner & Abramovitz**—Manufacturers of Diamond Jewelry. Specialty, Ring Mountings. 128 Fulton Street, Room 30, New York.

**Brown, Thos. G. & Sons**—Man'rs of Rich Jewelry Necklaces, Locketts, Bracelets, Sleeve Buttons, etc., 860 Broadway, N. Y.

**Bryant & Bentley**—Manufacturing Jewelers. Rings a specialty. 12 Maiden Lane

**Carter, Sloan & Co.**—Manufacturing Jewelers, 15 Maiden Lane, New York.

**Champanois & Co.**—No. 5 Maiden Lane, manufacturers of Engraved and Enameled Gold goods, in Sets, Ear Knobs, Bracelets, Studs, Lace and Shawl Pins, Jet cluster and Onyx goods, also "Best Lever" Sleeve Buttons.

**Chatellier, Joseph F.**—Manufacturing Jeweler, No. 694 Broadway, N. Y.

**Churchill, Lewis & Co.**—Manufacturers of Fine Jewelry. 692 Broadway, cor. Fourth St., N. Y.

**Cook, George W.**—Manufacturer of Fine Jewelry and Locketts, 191 Broadway (over Mercantile Bank,) N. Y.

**Cottle S. Co.**—Manufacturers of Fine Jewelry. 860 Broadway, N. Y.

**Cox & Sedgwick**—Manufacturers of fine Onyx and Colored Jewelry. 26 John St., New York

**Day & Clark**—Manufacturers of Fine Jewelry, Lace Pins, Ear Rings, Studs, Locketts, &c., 10 Maiden Lane, New York.

**Geoffroy, Arthur R. & Co.**—Manufacturing Jewelers. Novelties in Diamond Goods. No. 23 Maiden Lane, N. Y.

**Greene Wm. C. & Co.**—Goldsmiths; Manufacturers of Rich Sets in Taper Wire Coral. Office, 192 Broadway.

**Griffith, H.**—Manufacturing Jeweler. Gold and Plated Jewelry. Scarf Pins a specialty. Nutry Alley, near Concord St., Brooklyn, N. Y.

**Groschel & Rcsman**—Manufacturers of Fine Jewelry. No. 27 John Street, N. Y.

**Hartmann, P.**—Manufacturer & Importer of Fine Gold, Diamond, and Filigree Silver Jewelry, No. 36 Maiden Lane. P. O. Box 2,454.

**Hedges, A. J. & Co.**—Manufacturing Jewelers, 6 Maiden Lane.

**Henderson & Winter**—Jewelers, No. 15 Maiden Lane, New York. Specialties—Stone, Cameo, Onyx, Amethyst, Topaz, Pearl and Turquoise Rings.

**Jandorf, P. & Bro.**—Manufacturing and Wholesale Jewelers—all grades. Prompt Attention to Orders. We issue no catalogue. 196 Broadway, N. Y.

**Kipper, Vogel & Co.**—Manufacturing Jewelers, 17 Maiden Lane, New York.

**Kremetz & Co.**—Manufacturing Jewelers, No. 182 Broadway, N. Y.

**Kuhn, Doerflinger & Co.**—Manufacturers of Enameled and Roman Band Bracelets, also Fine Locketts Pendants and Lace Pins. 18 John street.

**Miller Bros.**—Manufacturers of Fine Jewelry, Diamond Goods, Sets, Lace Pins, Ear Rings, Scarf Pins, Sleeve Buttons, Studs, etc. 7 Maiden Lane, N. Y.

**Moore & Horton.**—11 Maiden Lane, Manufacturing Jewelers, Rings, Studs, Collars and Sleeve Buttons, Pins, Ear-rings, &c.

**Mulford & Bonnet**—No. 21 Maiden Lane, New York.

**Owen, G. & S. & Co.**—Manufacturing Jewelers. Office, No. 3 Maiden Lane.

**Richardson, Enos & Co.**—Manufacturers of Fine Gold Jewelry, Gold Chains, Locketts, Crosses and Necklaces. Colored and Etruscan Work. No. 23 Maiden Lane, New York.

**Richardson, J. W. & Co.**—Manufacturers of Jewelry. Masonic and other Emblems. 196 Broadway, N. Y. Manufactory, Providence, R. I.

**Riley, J. A. & Co.**—Manufacturing Jewelers. Etruscan Gold and Roman Bracelets, Lace Pins, Ear Rings, Scarf Pins, Brooch Pins, etc. No. 860 Broadway, N. Y.

**Ripley, Howland & Co.**—Manufacturers of Fine Jewelry and Platinum Tipped Diamond Settings. No. 17 Maiden Lane, N. Y.

**Schwencke, Wm.**—Manufacturing and Jobbing Jeweler. Repairing a specialty. Orders promptly attended to. No. 43 Maiden Lane, N. Y.

**Sexton & Cole**—Manufacturing Jewelers, Colored Gold and Onyx Goods a specialty. No. 30 Maiden Lane.

**Sheafer, W. H. & Co.**—Manufacturing Jewelers, Specialty Bangles and Bracelets, 15 John St., N. Y.

**Stites' Sons, E.**—Manufacturers of Fine Jewelry. No. 14 John Street, N. Y.

**Straat, E. A.**—Manufacturer of Fine Jewelry. Roman Goods, Rings, Diamonds. No. 43 Maiden Lane.

**Street, Geo. O. & Sons.**—Established 1837. Makers of Fine Jewelry, strictly first-class goods of our own make. No. 15 John Street, New York.

**Thoma, Ernest**—Manufacturer of Fine Jewelry, Sleeve Buttons, Rings, Ear-rings, &c. No. 173 Broadway, N. Y. Factory, Hackensack, N. J.

**Ward, Thos. M.**—Manufacturer of Fine Jewelry. Diamond Mountings a specialty. No. 25 John Street, N. Y.

**Wienhold, J.**—Manufacturer of Fine Jewelry. Diamond Mountings a Specialty. 24 John St.

**Woglom & Miller**—Manufacturers of Black Onyx Goods exclusively. 32 & 34 John Street, N. Y.

#### Jewelry—Rolled Plate.

**Blackinton, W. & S.**—Manufacturers of the W. & S. B. Rolled Plated Chains. No. 11 Maiden Lane.

**Mauran, J. T.**—Manufacturer of Fine Rolled Plate Jewelry, No. 15 Maiden Lane, N. Y.

**Richards, E. Ira & Co.**—Manufacturers of Fine Rolled Plate Jewelry, No. 200 Broadway, N. Y.

**Jewelers' Tools, etc.**

- Fisher, James J.**—Dealer in Watchmakers' and Jewelers' Materials, Files, Tools, Silk Guards, Spectacles, etc. 695 and 697 Broadway, N. Y.
- Friedenthal & Rypinski**—Importers and jobbers of Watchmakers' and Jewelers' Tools, Materials, etc. 43 Maiden Lane, N. Y.
- Friedlander, R. & L.**—Importers of Watchmakers' Tools and Materials. 65 & 67 Nassau Street. Branch Office, 264 Bowery.
- Koester, C. F.**—Importer and Manufacturer of Fine Tools, Files and Polishing Materials for Jewelers, Watch Case Makers, etc. 33 John St.
- Kurtz, F. P.**—Manufacturer of Jewelers Machinery, Tools, Rolling Mills, Presses, Polishing Lathes, &c. 97 Cliff St., N. Y.
- Levy, Dreyfus & Co.**—Importers and Jobbers of Watchmakers' and Jewelers' tools and materials of every description. 11 Maiden Lane, N. Y.
- Reichhelm, E. P. & Co.**—Importers of Jewelers' Tools, Files, etc. Manufacturers of Brushes and Buffing wheels; also Patent Gas Furnaces for Melting, Plating, Enamelling, Annealing, etc. 80 Nassau St., N. Y.

**Lapidaries.**

- Fox, M. & Co.**—Practical Lapidaries, No. 1 Maiden Lane, New York.
- Graham & Co.**—Practical Lapidaries, Cutters and Polishers of all kinds of Precious Stones, Emeralds, Rubies, Sapphires, etc. Miner's Relics Cut, Polished and Mounted. Locket Glasses. 80 Nassau St., N. Y.
- Kordmann & Michel.**—Lapidaries. Dealers in Precious Stones. Cutting and Polishing Rubies, Sapphires and other Gems a specialty. Drilling done promptly. 59 Nassau St., N. Y.

**Masonic Jewelry.**

- Luther, John F.**—79 Nassau Street. Manufacturer of Fine Presentation Jewels for all Societies. Knights Templars, Crosses, Badges, &c.
- Wilkinson, C. B.**—Manufacturing Jeweler, 8 John St., N. Y. Medals, Badges and Masonic Jewelry, a specialty. Designs furnished free upon application.

**Musical Boxes.**

- Paillard, M. J. & Co.**—Manufacturers of Musical Boxes and Musical Novelties. Warerooms, 680 Broadway, N. Y.

**Optical Goods.**

- Friedlander, R. & L.**—65 and 67 Nassau Street. Dealers in Optical Goods.
- Spencer Optical Manufacturing Co.**—Manufacturers of Spectacles and Eye-Glasses. 13 Maiden Lane, N. Y.

**Opticians.**

- Burbank Man'g Co.**—Manufacturers of Spectacles and Eye Glasses of all descriptions, in gold, silver, etc., 14 Maiden Lane, N. Y.
- DuBois, Geo. W. & Co.**—Importers of Watches and Optical Goods. 36 Maiden Lane, N. Y.
- Levy, Dreyfus & Co.**—Importers of Spectacles and Eye Glasses and Optical Instruments of every description, No. 11 Maiden Lane, N. Y.
- Lorsch, Albert**—Manufacturer of the Patent Accommodating Spectacles and Eye Glasses in Gold, Silver and Steel, and other Optical Goods, 37 Maiden Lane, N. Y.
- Spencer Optical Manufacturing Co.**—Gold, Silver, Steel, Nickel and Plated Spectacles; Gold, Celluloid, Steel, Nickel and Rubber Eye Glass and Opera Glasses. 13 Maiden Lane, N. Y.
- Todd, James W.**—No. 20 Maiden Lane, N. Y. Wholesale Dealer in Optical Goods.

**Paper Boxes.**

- Lehmann, Ludwig.**—Manufacturer of Jewelers' Findings. 122 Fulton St., near Nassau, N. Y.
- Waterbury Paper and Box Co.**, 27 to 35 Canal St., Waterbury, Conn., Manufacture Jewelers' and Silversmiths' Fine Paper Boxes. Quality guaranteed to be equal to the best made.

**Polishers and Lappers.**

- Klees & Co.**—Late Abels, Polishers and Lappers of Fine Jewelry. 89 Nassau St., Room 17, N. Y.

**Precious Stones, &c.**

- Bishop, Victor & Co.**—35 Maiden Lane, Importers of Precious Stones, Cameos, &c. Also Manufacturers of Coral Jewelry.

**Bissinger, Philip & Co.**—Importer of Diamonds, Pearls and Precious Stones. Agent for the Bohemian Garnet Goods. Blue Enameled Locketts and Coral Goods. No. 22 John St., N. Y.

**Breidenbach, R. A.**—Importer of Black Onyx, Diamonds, Pearls, Turquoise, Cameos, Sardonyx, Amethysts, Garnets, Topaz, Opals, Rubies, Sapphires, Hematite Balls, Foil Brilliants, Cat's-Eyes, Tiger Eyes, Doublets, Cabinet Specimens, etc. 85 Nassau Street, New York.

**Daue, Wm. & Co.**—Importer of Precious and Imitation Stones. No. 202 Broadway New York.

**Fox, M. & Co.**—Importers of Diamonds and other Precious Stones, No. 1 Maiden Lane, N. Y.

**Gruet, Jules.**—Importer of all Grades of Real and Imitation Stones. 14 John St., N. Y.

**Hahn & Co.**—Importers of Precious Stones, Cameos, Onyx, Pearls, Intaglios, Amethysts, Garnets, etc. 64 Nassau Street, New York.

**Kahn, L. & M. & Co.**—Importers of precious and imitation stones. 10 Maiden Lane, N. Y.

**Kipling, E. E.**—Importer of Precious and Imitation Stones. Manufacturer of the Patent Foil Solid Metal Back Rhine Stone Brilliant. No. 6 Maiden Lane, N. Y.

**Kipling, R. A.**—Precious and Imitation Stones, No. 24 Maiden Lane, N. Y. Manufacturer Cameos, Agates, Onyx, etc., Oberstein, Germany. Commission Merchant, 49 Rue De L'Echiquier, Paris.

**Lorsch, Albert**—Importer of Precious Stones, 37 Maiden Lane, N. Y.

**Stirn, Oppenheimer & Co.**—Importers of Black Onyx, Cameos, Turquoise, Sardonyx, Garnets, Rubies and all other Precious and Imitation Stones. German, French and Vienna Novelties. 3 Maiden Lane, N. Y.

**Safes.**

**Butler, W. H.**—Fire and Burglar Proof Safes, 291 Broadway, N. Y.

**Silverware.**

**Dominick & Haff**—Makers of Wares in Sterling Silver for the Trade only. Broadway and 17th Street, Union Square, New York.

**Gorham Manufacturing Co.**—Broadway and 19th Street.

**Knowles, J. E. & S. M.**—Manufacturers of Sterling Silverware, 20 Maiden Lane, N. Y. Factory, Providence, R. I.

**Shiebler, Geo. W.**—Manufacturer of Sterling Silverware. No. 8 Liberty Place, near Maiden Lane, N. Y.

**Whiting Manufacturing Co.**—Makers of Sterling Silver Ware. Broadway cor. 4th Street, N. Y.

**Wood & Hughes.**—Manufacturers of Fine Silverware. 16 John Street, N. Y.

**Silver Filigree Jewelry.**

**Cuppia, L. A.**—Manufacturer of Solid Silver Novelties, and Importer of Silver Filigree, 19 Union Square.

**Francesconi, Guido**—Importer of Silver Filigree Jewelry, 196 Broadway, New York.

**Hartmann, P.**—Manufacturer of Silver Filigree Jewelry. 36 Maiden Lane, N. Y.

**Silver Plated Ware.**

**Manhattan Silver Plate Co.**—Manufacturers of Silver Plated Ware. Showrooms, 23 John St. Factory, 301 to 305 East 22d St., cor. 2d Ave. Address all communications to Factory.

**Middletown Plate Co.**—Manufacturers of Superior Electro-Plate. Factories, Middletown, Conn., salesroom, 13 John Street.

**Rogers, Smith & Co.**—Manufacturers of Fine Electro Plated Ware. No. 46 E. 14th St., N. Y.

**Rogers & Brother**—Manufacturers of Electro-Plated Flat and Hollow Ware. 690 Broadway, N. Y.

**Schade, Henry.**—Manufacturer of White Metal and Plated Ware. Office, 26 John Street, N. Y. Price list and catalogue furnished on application.

**The Derby Silver Co.**—Manufacturers of Finest Quadruple Silver Plated Ware, Birmingham, Conn. New York office, 25 Maiden Lane.

**Webster, E. G. & Bro.**—Manufacturers of Fine Silver-Plated Ware. Office and warerooms, 14 Maiden Lane, N. Y.

**Show Cases, Etc.**

**Smith, B. & W. B.**—Manufacturers of Patent Improved Dust Proof Show Cases, with Perpendicular Sliding Doors, No. 220 W. 29th St., N. Y.

**Spectacle Case Manufacturers.**

**Bertine, P. D.**—Manufacturer of Spectacle and Eye-Glass Cases. 139 William Street, near Fulton St., New York.

**Koenen, A. & Bro.**—Manufacturers of Leather Spectacle and Eye-Glass Cases for the Jobbing Trade only. 81 Nassau St., N. Y.

**Spencer Optical Manufacturing Co.**—Manufacturers of Spectacle and Eye-Glass Cases. 13 Maiden Lane, N. Y.

**Stem Winding Attachments.**

**Abbott, Henry** Maker of Stem Winding Attachments, No. 4 Maiden Lane, N. Y.

**Swivels and Spring Rings.**

**Schwartz, V. & Co.**—Manufacturers of Gold Swivel and Chain Trimmings. 33 Barclay Street, New York.

**Thermometers, Etc.**

**Tagliabue, Giuseppe.**—manufacturer of Thermometers, Barometers and Hydrometers. Patentee and sole manufacturer of the U. S. Standard Hydrometer. 302 Pearl Street, near Beekman.

**Thimble Manufacturers.**

**Ketcham & McDougall.**—Improved Gold and Silver Thimbles, Bryant Building, N. Y.

**Simons Bro. & Co.**—Manufacturers of Gold and Silver Thimbles. 611 and 613 Sansom Street, Philadelphia.

**Woglom & Miller.**—Sole Agents for the "Prime" Thimbles in Gold and Silver, manufactured by Ezra C. Prime. 34 John Street, N. Y.

**Trunks.**

**Crouch & Fitzgerald**—Manufacturers of Trunks and Articles for Travelers' use. 1 Cortlandt St., 556 Broadway, and 723 Sixth Ave., N. Y.

**Watch Companies.**

**American Watch Co.**—Robbins & Appleton, No. 5 Bond Street, N. Y.

**The E. Howard Watch and Clock Co.**—Cor. Maiden Lane and Nassau Street, N. Y.

**Waterbury Watch Co.**—Manufacturers of the Waterbury Watch. Factory, Waterbury. Office, 52 Maiden Lane, N. Y.

**Watch and Chronometer Jewelers.**

**Queen, James.**—Watch and Chronometer Jeweler and Pallet Maker, 78 Nassau Street, room 8. Pivots inserted in Pinions, Balance, Staffs, etc.

**Robert, Henry L.**—Practical Chronometer and Watch Jeweler and Adjuster. 71 Nassau Street. Pallet and Hole Jewels for Chronometer Watches done in the best manner.

**Wennstrom, John.**—Watch, Chronometer and Clock Jeweling, Jewel Gauges, Ruby and Sapphire Draw Plates; Diamond Charged Polishing Stones for Jewel Settings; Pivots inserted in Pinions. 2 Dutch Street, N. Y.

**Watch Importers, Etc.**

**Abry, Chas. Leo**—Importer and Manufacturer of Swiss Watches of all grades. 63 Nassau Street.

**Aikin, Lambert & Co.**—Importers of Watches. Sole Agents for Paul Breton & Chas. Latour, Geneva. A general line of reliable Swiss Watches, Watch Cases, etc. 23 Maiden Lane, N. Y.

**Bartens & Rice**—20 John Street, Importers of Watches and sole agents in the United States for the celebrated Nicole, Nielsen & Co. Watches.

**Cross & Beguelin.**—Importers of Watches, Watch Tools and Materials, dealers in American Watches, No. 21 Maiden Lane, N. Y.

**Droz, Henry E.**—Importer of Watches, and Watch Case Manufacturer. Agent for the "E. Perregaux" Watch, and jobber in American Watches No. 92 Fulton Street, N. Y.

**Freund Max & Co.**—Importers of Watches, Jewelry and Precious Stones, 8 Maiden Lane, N. Y.

**Gagnebin, Chas.**—Importer of all kinds of Swiss, and Dealer in American Watches. 4 Maiden Lane, N. Y. Agent for Ulyse Breting's Fine Chronometers, Chronographs, Anchors, &c.

**Gallet, Julien.**—Importer of Watches. No. 1 Maiden Lane.

**Ginnel, Henry.**—Importer of Watches, Tools and Materials, 31 Maiden Lane, N. Y. P. O. Box 2967

**Hyde's Sons, John E.**—Wholesale Commission Agents, only for Jules Jurgensen, of Copenhagen; Jules Monard, of Geneva; and for other makers of all qualities of Watches, 22 Maiden Lane.

**Keller, L. H. & Co.**—Successors to G. A. Huguenin, Importers of Fine Watch and French Clock Materials, No. 64 Nassau Street, N. Y.

**Mathey Bros. & Mathez.**—Importers of Fine Watches and Sole Agents for the **H. L. Matile's** Watches. No. 16 Maiden Lane.

**Robert, J. Eugene.**—No. 30 Maiden Lane, New York. Agent for Louis Audemar's celebrated watches.

**Schumann, Chas. W.**—No. 24 John Street, New York. Importer of Fine Diamonds, Watches, etc. Sole Agent in the U. S. for the celebrated "Lange" Dresden Watch.

**Schwob, Adolphe.**—Manufacturer and Importer of Watches, 5 Maiden Lane, N. Y.

**Strasburger, Louis & Co.**—Importers and Makers of Watches of every description, 15 Maiden Lane.

#### Watch Cases.

**Dueber Watch Case Mfg Co.**—Manufacturers of Gold and Silver Watch Cases. Bryant Building, N. Y. Factory, Newport, Ky.

**Fahys, Joseph.**—Manufacturer of Watch Cases and Dealer in American Movements, 38 Maiden Lane.

**Keller & Untermeyer.**—Manufacturers of Watch Cases with Raised Gold Ornaments. 9 Maiden Lane, N. Y.

**Ladd Watch Case Co.**—Manufacturers of the Ladd Patent Stiffened Gold Watch Cases, etc., 11 Maiden Lane, N. Y. Factory, 58 Eddy Street, Providence, R. I.

**Tissot, H.**—Manufacturer of Gold Watch Cases. No. 15 Maiden Lane, N. Y.

**Willemin Watch Case Co.**—Makers of Gold Watch Cases. Raised Gold Ornamentation and Jurgensen style of Engine Turning. 109 Sands Street, Brooklyn, N. Y. 16 Maiden Lane, N. Y.

#### Watch and Chronometer Repairers.

**Cerf, B.**—Practical Watchmaker and Repairer, No. 10 John Street, N. Y. Repairing and adjusting of Fine Watches done for the trade. All kinds of escape and stem-winding wheels cut to order.

**Goepf, Frederick A.**—Practical Watchmaker. Repairing of every description for the Trade. 25 Maiden Lane, N. Y. In office of H. Garland, Engraver.

**Heinrich, H. H. & Co.**—Sole Manufacturers of H. H. Heinrich's Patent Auxiliary Balance, and Adjusters and Repairers of Fine Watches and Chronometers. 18 John Street, N. Y.

**La Croix, J. H.**—(Late with Benedict's Time.) Watch and Clock Maker, 21 John Street, N. Y. Clocks of every description Repaired for the Trade.

**Lesperance, Theo.**—Watchmaker and Wheel Cutter. No. 1 Maiden Lane, New York. With Julien Gallet.

#### Watch Case Repairers.

**Feinier, Joseph A.**—Watch Case Maker and General Repairer. Specialty in fine Gold and Silver Cases. Jobbing promptly attended to. Nos. 4 and 6 John St., N. Y.

**Tarbox, Hiram.**—Watch Case Repairing, Springing, Polishing and Engine Turning. 1874 North Fourth Avenue, bet. 176th and 177th Sts., N. Y. Express Packages should be sent to 92 Fulton Street.

#### Watch Classes, Shades, Etc.

**Brown, Edwin H.**—No. 85 Nassau Street, Imported and Own Manufacture Watch Glasses, Flat, Flat Concave, Concave, Convex and fine Genevas. Fine fitting solicited.

#### Watches, Diamonds and Jewelry.

**Alford, C. G. & Co.**—Manufacturers. General line fine and Reliable Goods. Specialties in Onyx Goods and Chain. 200 Broadway, New York.

**Bynner, T. B.**—Watches, Diamonds and Jewelry. Also a full line of best quality Roll Plated Jewelry. 908 Broadway, between 20th and 21st Streets, Continental Hotel, New York.

**Cohn, J. J.**—Importer and Manufacturer of Whitby Jet, Rubber and Pearl goods. Gold and Rolled-plate Jewelry, etc. 12 Maiden Lane, New York.

**Durfey & Reynolds.**—Successors to Durfey & Shiebler, Watches, Diamonds, Jewelry. No. 9 John Street, (up-stairs) New York.

**Goddard, John M.**—Manufacturing Jeweler.—Seal Rings and Fine Locketts a specialty, No. 3 Maiden Lane, N. Y.

**Greason J. R. & Co.**—Successors to Arthur, Rumlill & Co., 182 Broadway. Manufacturers of Fine Jewelry and Gold Chains, also Diamond Mountings.

**Haskell, H. C.**—Manufacturing Jeweler. Seal Rings a specialty. Special attention to Jobbing of every description. 12 John street.

**Herzog, Louis & Co.**—Importers of Watches, Dealers in Diamonds and Jewelry, 52 Maiden Lane, N. Y.

**Hirsch Bros.**—Dealers in Watches and Diamonds and Manufacturers of Jewelry, No. 23 Maiden Lane, N. Y.

**Jandorf, P. & Bro.**—Importers of Watches and Jewelry, 196 Broadway.

**Lissauer & Sondheim.**—Wholesale Jewelers and Jobbers in American Watches, No. 12 Maiden Lane, N. Y.

**Marx, Kossuth & Co.**—Importers of Watches and Dealers in Jewelry. 39 Maiden Lane, N. Y.

**May, Henry.**—Importer and Wholesale Dealer in Watches and Diamonds, and Manufacturing Jeweler. 19 John St., N. Y.

**Mayer, B.**—Manufacturer of Fine Jewelry, and Dealer in Watches, 71 Nassau street, cor. John street, New York.

**Myers, S. F. & Co.**—Manufacturing and Wholesale Jewelers—all grades. Importers of Watches. Illustrated Catalogue to the trade. 179 Broadway, N. Y.

**Oppenheimer Bros. & Veith.**—Dealers in Watches and Diamonds, and Manufacturing Jewelers, No. 35 Maiden Lane.

**Scott, J. T. & Co.**—Importers of Watches, and Manufacturers of Jewelry, and Jobbers of all Grades of American Watches, 4 Maiden Lane.

**Smith & Knapp.**—Wholesale Dealers in American and Swiss Watches, Diamonds, Gold and Plated Jewelry and Gold Chain. 182 Broadway, N. Y.

**Steele, J. W.**—Successor to Brainerd, Steele & Co., Manufacturer of Fine Jewelry and Brainerd's Patent Locketts. No. 9 Maiden Lane, N. Y.

**Stern & Stern.**—Dealers in Watches, Jewelry and Diamonds. No. 6 Maiden Lane, N. Y.

**Stites, D. H. & Son.**—Manufacturers of Fine Jewelry, Rolled Plated Goods and Chains, Parisian Diamond Rings, Studs and Earrings a specialty. 41 Maiden Lane, N. Y.

**Strauss, Jacob.**—Full Line of Gold and Plated Jewelry, and Importer of Watches. 18 John Street, New York.

**Thrall, E. A.**—Wholesale Dealer in Watches and Jewelry. No. 1 Maiden Lane, N. Y.

**Trier Bros.**—Importers of Garnet, Whitby Jet and Amber Jewelry, Silk Guards, Opera, Field and Marine Glasses, Pearl Card Cases. Also a full line of Gold and Plated Jewelry. 15 Maiden Lane, N. Y.

**Wheeler, Parsons & Hays.**—Manufacturers of Fine Jewelry, Watch Cases, Gold Chains, &c. and Dealer in American and Swiss Watches, No. 2 Maiden Lane, N. Y.

**White, N. H.**—Jobber in American-Waltham Watches and Chronographs. Waltham make of 10-k., 14-k. and 18-k. Gold and Sterling Silver Cases; Filled Gold Cases. 11 Maiden Lane.

#### Watch Tools, etc.

**Keller, L. H. & Co.**—Importers of Watchmakers' and Jewelers' Tools, Materials, etc. 64 Nassau Street, N. Y.

**Zimmern, Henry.**—Importer of Watch Materials, Tools, and Optical Goods, No. 8 Maiden Lane, (first floor.) Sole Agent for A. Huguenin & Gravier, Mainsprings, New York.

## PHILADELPHIA

**Bennett, Jacob & Son.**—Diamond Setters and Manufacturing Jewelers, 925 Chestnut St.

**Bernard & Co.**—Manufacturers of Fine Roman and Etruscan Jewelry. Designs of every description made to order, 123 & 125 South Eleventh Street, Philadelphia.

**Booz & Co.**—Makers of Fine Gold Watch Cases and Plain Gold Rings, also Dealers in all American Movements, Diamonds, Jewelry, etc. 108 South 8th Street, Philadelphia.

**Conover David F. & Co.**—American Watches, Wholesale Salesroom, Southeast corner 7th and Chestnut Streets, Philadelphia.

**Krieder, Peter L.**—Manufacturer of Sterling Silver Ware. 618 Chestnut Street, Philadelphia.

**McCall & Newman.**—Manufacturing Jewelers. Makers of the Original Gold Crown Filled Rings. No. 625 Arch St., Philadelphia.

**Morgan & Headly.**—Manufacturing Jewelers. Cameo Sets, Gold Sets, Roman Locketts, Rings, Coral Sets and a general line of rich goods. Corner 10th and Chestnut Streets, Philadelphia.

**Peters, Reese S.**—Manufacturer of Patent Rolled Plate or Filled Watch Cases, Dealer in American Movements, 308 Chestnut Street, Philadelphia.

**Rosenthal, G. F. C.**—Manufacturing Jeweler and Diamond Setter. Engraving and Designing of Monograms a specialty. No. 917 Sansom Street.

**Scherr, L. A. & Co.**—Wholesale Dealers in Watches Silver-Plated Ware, Spectacles, Fancy Goods, Watch Materials, etc. 726 Chestnut Street.

**Sheafer, W. H. & Co.**—Manufacturing Jewelers. Specialty: Band Bracelets. Factory, 612 and 614 Chestnut street, Philadelphia. Office, 15 John street, New York.

**Simons, Brother & Co.**—Manufacturers of Fine Jewelry, Canes, Thimbles, Chains. 611 and 613 Sansom Street.

## CHICAGO.

**American Watch Company.**—of Waltham, Mass. No. 102 State Street, Chicago.

**Clapp & Davies.**—Wholesale Jewelers, 63 and 65 Washington Street. Catalogue and price list issued to watchmakers and jewelers.

**Dennison Manufacturing Co.**—Manufacturers of Jewelers' Paper Boxes, Morocco Cases, Tags, Cards, Pink and White Cotton, Tissue Papers, Sealing Wax, &c., &c., 102 Madison St., Chicago. Boston, New York, St. Louis, and Philadelphia.

**Gilbert, Wm. L., Clock Co.**—Manufacturers of Clocks, Regulators, and Time Pieces, and Clock Material of every description, 54 and 56 Madison Street, Chicago.

**Giles, Bro. & Co.**—Manufacturers and Jobbers in Watches, all classes of Jewelry, Materials, Clocks, Silver Ware, &c. Illustrated catalogues furnished to dealers on application. 101 & 103 State St.

## NEWARK.

**Baker & Co.**—Gold, Silver and Platinum Refiners Assayers and Sweep Smelters. 408 New Jersey Railroad Avenue, cor. Murray St., Newark, N. J.

**Diefenthaler Bros. & O'Donnell.**—Manufacturers of Fine Jewelry, Lace Pins, Ear Rings and Patent Spring Bangles a Specialty. 36 Crawford Street, Newark, N. J.

**English & Miller.**—Manufacturers of Gold Jewelry, Diamond and Fancy Stone Rings, Roman Locketts, Bangle and Flexible Bracelets, Knife Edge Lace Pins and Sets, Scarf Pins and Link Buttons. 61 and 63 Hamilton St., Newark.

**Felger, F. & F.**—Manufacturing Jewelers. Specialties:—Roman Band Bracelets, Lace Pins, Scarf Pins, Ball and Fancy Ear Rings. No. 477 Washington Street, Newark, N. J.

**Fiedler, Herrman.**—Successor to Kunze & Fiedler, Engraver, Die Sinker and Press Tool Maker, 363 Market Street, Opposite Pennsylvania R. R. Depot, Newark, N. J.

**Glorieux, W. L.**—Assayer, Refiner and Sweep Smelter. 13 and 15 Franklin Street, Newark, N. J.

**Hopper & Wilson**—Manufacturers of Fine Jewelry, No. 8 Maple Place, Rear 44 Green St., Newark, N. J.

**Huger & Heitlinger**—Manufacturers to the Jobbing Trade only. Makers of Roman, Stone, Engraved and Enameled Locketts a specialty. Also Sleeve Buttons, Collar Buttons and Studs. 477 Washington Street, Newark, N. J.

**Krippendorf, C. & Schuller, F.**—Machinists and Jewelers' Tool Makers. 19 Greene Street, Newark, N. J. Rolls, Dies, Cutters, and Draw-plates of every Description made and repaired.

**Lelong, L. & Bro.**—Gold and Silver Refiners, Assayers and Sweep Smelters, Southwest corner of Halsey and Marshall Streets, Newark, N. J.

**Milne, Alex.**—Manufacturer of Stem-winding Watch Crowns. 19 Ward Street.

**Nesler & Co.**—Manufacturers of 18 Kt. Gold Filled Hoop Ear Rings, Plain, Facet and Engraved, all sizes. 36 Crawford St., Newark, N. J.

**Regad, E. D.**—Lapidary. Specialty—Sardonyx, Black Onyx and Agates. 14 Oliver St., Newark.

**PROVIDENCE**

**Arnold & Webster**—Manufacturers of Solid Gold Engraved Band Rings for the Jobbing Trade. 29 Point Street, Providence, R. I.

**Butts, Geo. F.**—Manufacturing Jeweler. Ladies' and Misses' Solid Gold Drops and Studs a Specialty. 119 Orange Street, Providence, R. I.

**Bradley, R. & Son**—Manufacturers of Solid Gold and Rolled Plate Jewelry. White Stone Goods a Specialty. 227 Eddy Street, Providence, R. I.

**Capron & Co.**—Manufacturers of Jewelry. Engraved Box Bracelets, Bangle Wire Bracelets, Original Lever Collar and Cuff Button. No. 407 Pine Street, Providence, R. I.

**Elmwood Paper Box Co.**—Makers of Jewelers' Cases, Trays, etc. Factory, 54 Greenwich St., Providence, R. I.

**Fry & Read**—Manufacturers of Sterling Silver and Gold Plated Jewelry. Antique Work a Specialty. 28 Potter Street, Providence, R. I.

**Hamilton, William & Co.**—Manufacturers of Fine Rolled Plated Chains and Patent Band Bracelets. 116 Pine St., Providence, R. I.

**Harrington, J. C.**—Maker of Fine Gold Plated Jewelry. Specialties:—Oval Wire Bangles, Band Bracelets and the Victor Swivel. 129 Eddy St., Providence, R. I.

**Hough, W. S., Jr., & Co.**—Manufacturers of the Hough, Jr., Rolled Plate Locketts, Charms and Pendants. For sale by all first-class Jobbers or Wholesale Jewelers in the United States and Canadas.

**Hutchison & Huestis**—Makers of Solid Gold Rings. Quality guaranteed. For the Jobbing Trade only. 185 Eddy Street, Providence, R. I.

**Irons, Chas. F.**—Manufacturer of Solid Gold Jewelry. Specialty, Emblems, Pins and Charms, Masonic, Odd Fellows, etc. 102 Friendship St.

**Pitts & Hicks**—Manufacturers of the Excelsior Button and Eclipse Lever Button, also a line of White Stone Gold Goods and a fine line of Lace Pins and Drops in Rolled Plate Goods. 120 Dorrance Street, Providence, R. I.

**Taylor, Geo. H. & Co.**—Watchmakers and Wholesale Dealers in Watches, Clocks, Watch and Clock Material, Tools, Spectacles, Eye Glasses, &c. Particular attention given to trade work. 136 Westminster Street (Room 1), Providence, R. I.

**Waite, Smith & Co.**—Manufacturers of Gold and Plated Jewelry. Gold Chain Trimmings a Specialty. Plated Stone Rings. White Stone Goods. 61 Peck Street, Providence, R. I.

**PAWTUCKET.**

**Fuller, Geo. H. & Son**—Jewelers' Findings, Gold, Silver, Gold Plated and Fire Gilt. Pin Stems, Joints, Catches, Split Rings, Chain Hooks and Swivels, Ear Wires, Chain Bars, etc. 99 Exchange Street, Pawtucket, R. I.

**CINCINNATI.**

**Holland, John**—Manufacturer of Gold Pens, Pencils and Pencil Cases, Gold Toothpicks, etc. Nos. 19 and 21 W. 4th St., Cincinnati, Ohio.

**Lodwick & Nolting**—Wholesale Jewelers (exclusively), S. W. cor. Fourth and Walnut Streets, Cincinnati, Ohio.

**BOSTON.**

**Boston Watch Case Co.**, makers of Watch Cases. Especial attention given to Repairing. 1, 3 & 5 Province Court, Boston, Mass.

**Boyce, E. J.**—Manufacturer of Solid Gold Jewelry. Rings a Specialty. 383 Washington St., Boston, Mass.

**Thiery Watch Case Co.**—Sole Manufacturers in the United States of Solid Nickel and Nickel Silver Cases. 309 Washington Street, Boston, Mass.

**Weber, H. & Co.**—Wholesale Jewelers, Importers and Jobbers of Fine Watch Materials, Jewelers' Findings, Tools, etc., Optical Goods and Silk Guards. Agents for Whitcomb, Standard and Stark's Lathes. 424 Washington St., Boston, Mass.

**BUFFALO.**

**Klein, E. F. O.**—Jobber in Watch Materials. Watches and Chronometers repaired and adjusted for the trade; also Gold and Silver Plating. Sample Bottle of "Magic Solution," for cleaning Watches, including receipt, to any address, on receipt of \$1.50. This is a great time-saver and does the finest work. No one will do without it if used once. 346 Broadway, Buffalo, N. Y.

**Oliver, W. W.**—Manufacturer of Hand and Power Rolling Mills for Jewelers and Silversmiths, 39 Clinton Street, Buffalo, N. Y.

**CLEVELAND.**

**Chandler, J. M. & Co.**—Manufacturers of the Patent Embossed Bracelet and Jobbers in all kinds of Clocks, Watches, Jewelry, Tools, Materials, etc. 185 Superior St., Cleveland, O.

**LANCASTER.**

**Bowman & Musser**—Jobbers in Watches, Clocks, Chains, Fine Tools and Materials. 20 East Chestnut Street, Lancaster, Pa.

**PITTSBURGH.**

**Barrett, G. B., & Co.**—Wholesale Jewelers and Diamond Importers. We carry a line of everything required by the trade. Lowest prices guaranteed. 101 Fifth Avenue, Pittsburgh, Pa.

**Goddard, Hill & Co.**—Wholesale Dealers in American Watches, Jewelry, Silverware, Clocks, Materials, &c., 43 Fifth Avenue, Pittsburgh, Pa.

**Hodge, Slemmons & Co.**—Wholesale Dealers in American and Swiss Watches, Diamonds, Gold and Plated Jewelry, Clock Material, etc. No. 77 Fifth Ave., Pittsburgh.

**NEW BEDFORD.**

**Nye, W. F.**—Manufacturer of Watch, Clock and Chronometer Oils, New Bedford, Mass.

**Wheeler, G. B.**—Manufacturer of Watch and Chronometer Oils, New Bedford, Mass.

**WORCESTER.**

**Washburn & Moen Manufacturing Co.**—Makers of Fine Watch Mainsprings, Worcester, Mass. 16 Cliff Street, New York. 107 to 109 Lake Street, Chicago, Ill.

**WINCHESTER.**

**Goodell & Winn**—Manufacturers of American Watch Hands, Winchester, Mass.

**ALBANY.**

**Reiss, Chas.**—31 and 33 So. Pearl Street, Albany, N. Y. Importer of Watch Tools and Material; General Supply; Low Prices. Repairing for the Trade.

**KEOKUK, IOWA.**

**Ayres, T. R. J., & Sons**—Wholesale Jewelers. Watches, Jewelry, Diamonds, Silverware, Clocks, Optical Goods, Tools, Material, &c, at lowest eastern prices. Correspondence solicited.

**CANADA.**

**Ellis, P. W. & Co.**, No. 31 King street, East Toronto, Ontario, Manufacturing Jewelers, Watchmakers, importers and Jobbers of Watchmakers, and Jewelers' Tools, Materials, General Supplies and American Jewelry. Correspondence solicited with manufacturers of Novelties or specialties in American Tools and Jewelry.

GEO. W. DUBOIS.

F. N. NAUMAN.

**GEO. W. DUBOIS & CO.,**

IMPORTERS OF

**Watches & Optical Goods.**

ALL STYLES AND QUALITIES OF

**SPECTACLES AND EYE-GLASSES.**

**Longines' Watches and Movements,**

The Watches in Gold, Silver and Nickel Cases of New and Handsome Patterns. The Movements fit 18 size Waltham Stem Winding Hunting Cases.

**36 Maiden Lane, New York.**

ORDERS BY MAIL RECEIVE PROMPT ATTENTION.

**BARNES' No. 4 LATHE, For the Heavier Work of Jewelers.**

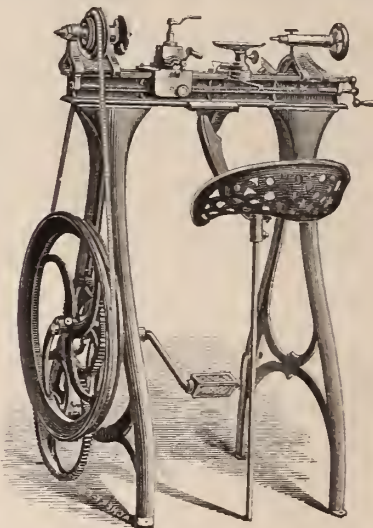

Barnes' Patent Foot and Steam Power Machinery. Complete outfits for Actual Workshop Business. Lathes for wood or metal. Circular Saws, Scroll Saws, Formers, Mortisers, Tenoners, etc., etc. Machines on trial if desired. Descriptive Catalogue and Price List Free.

**W. F. & JOHN BARNES, 2088 Main Street, ROCKFORD, ILL.**

**Watchman's Improved Time Detector WITH SAFETY LOCK ATTACHMENT, Patented 1875, '76, '77, '80, '81, '82.**

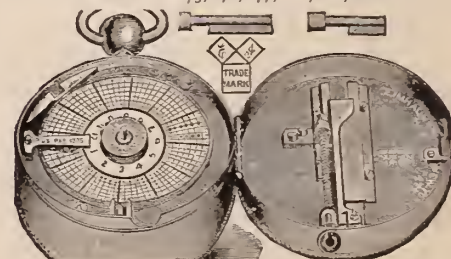

This instrument is supplied with 12 keys. Invaluable for all concerns employing watchmen. It contains all modern improvements, and is far superior to the old style. 1883—At the National Exposition for Railway Appliances at Chicago. The only Medal for the most complete and Perfect Instrument. P. O. Box 2875. Send for Circulars to **E. IMHAUSER, 212 Broadway, New York.**



**E. J. BOYCE,**  
MANUFACTURING JEWELER,  
Solid Gold Rings a Specialty.

My BAND RING Specialties, for PRICE, QUALITY and FINISH, are not equalled by any in the Trade.

383 WASHINGTON ST.,  
BOSTON, MASS.

Washburn & Moen M'fg. Co.,  
WORCESTER, MASS.

Manufacturers of Fine Watch Mainsprings for American, Swiss and English Watches, which, for Toughness, Elasticity and Finish, are Unequaled.

N. Y. Warehouse: Chicago Warehouse:  
16 Cliff Street. 107 to 109 Lake St.

Solid Gold Rings a Specialty.  
**WM. H. ELY,**  
SOLID GOLD RINGS,  
MANUFACTURER.

Viz., Plain, Chased, Engraved, Enameled, Engine Turned, Shield and Scale. All qualities guaranteed. Orders Promptly Executed.  
58 Nassau Street, New York.

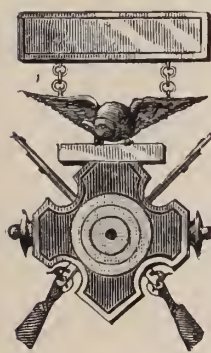

**C. B. WILKINSON,**  
Manufacturing Jeweler,  
S JOHN ST., N. Y.  
Medals, Badges and  
Masonic Jewelry  
A SPECIALTY.  
Designs furnished free  
upon application.

**C. KNAPP,**  
Manufacturer of  
Superior Band  
and Children's  
Stone & Fancy  
**RINGS**  
And Enameled Goods,  
41 Maiden Lane,  
NEW YORK.



**F. G. CRANDALE,**  
WATCHES AND DIAMONDS,  
16 Maiden Lane, New York.

Adjustments for  
Heat and Cold. Isochronism and Positions  
established in Watches and Marine  
Chronometers.

THE YALE COLLEGE OBSERVATORY  
has awarded 1st Class Certificates for my  
total entry of nine watches during the past  
year, 100 per cent. having stood their severe  
tests.

See report of Yale College Observatory in this number of  
THE CIRCULAR.

MONOGRAM ALBUMS  
2 Letter Alphabet, - \$5 00  
3 & 4 " - 10 00  
HANDSOMELY BOUND.



No Jeweler should be without it.  
Sent for examination, both  
expressages, if returned, to be  
paid by party ordering.

LEVY, DREYFUS & CO.,  
11 MAIDEN LANE, N. Y.

**HIBBARD G. GILL,**  
GOLD AND SILVER

Watch Case Manufacturer,

Dealer in Watches,  
American Watch Movements Always on Hand.  
618 Chestnut Street,  
Fifth Floor. PHILADELPHIA.

**HENRY TROEMNER,**  
710 Market Street,  
PHILADELPHIA.

Manufacturer of Fine Gold Scales,  
DIAMOND SCALES,  
Bullion Balances and  
Weights, in use at all the  
U. S. Mints and Assay  
Offices.

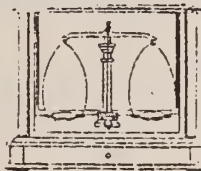

PRICED CATALOGUE ON APPLICATION.

**BUERK'S WATCHMAN'S TIME DETECTOR.**

20 Prize Medals Awarded.  
Safety Lock Attachment Patented  
April 25, '82.  
Used by all large manufacturing  
establishments, public buildings,  
warehouses, etc., to control watch-  
men. The simplest, strongest,  
cheapest and most complete of its  
kind made.  
Price, with pouch, 400 paper dials,  
record book, and 12 different keys  
with chains for 12 different stations,

COMPLETE, \$50.00.  
**O. E. HAUSBURG,**  
71 NASSAU ST., Room 3,  
P. O. Box 1239, NEW YORK.

**H. WASDELL,**  
RUBBER STAMPS,  
BRASS STAMPS,  
Brushes, Inks, &c.  
Stencil Plates,  
**STEEL STAMPS.**  
Burning Brands,  
SEALS & PRESSES,  
No. 7 North William St.  
First house South of East River Bridge, N. Y.

FINE STEEL STAMPS A SPECIALTY.

**J. WIENHOLD,**  
Manufacturer of Fine Jewelry,  
DIAMOND MOUNTINGS  
A SPECIALTY.

24 JOHN ST., N. Y. CITY.

**JNO. F. LUTHER,**

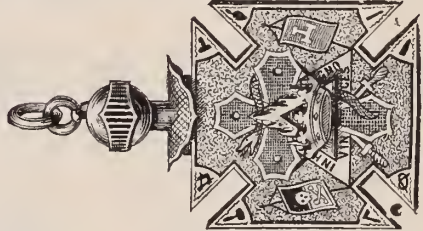
MANUFACTURER OF  
Masonic Jewelry.  
  
79 Nassau Street, N. Y.  
Illustrated Catalogue sent on application

**SAMUEL EAKINS, Jr.,**  
PRACTICAL  
Electro Gold and Silver Plater,  
618 CHESTNUT ST.,  
3d Floor, Rooms 11 & 12. PHILADELPHIA.

Repairing, Re-Plating and Gilding in the  
best manner.  
Oxidizing, Platinizing and Coloring of Jewelry  
a Specialty

**ENGRAVING DIRECT FROM PHOTOGRAPH.**  
NO DRAWING REQUIRED.  
NO HAND WORK NECESSARY.  
SEND (CHEAP, ARTISTIC) FOR PARTICULARS.  
CROSSCUP & WEST ENG. CO.  
702 CHESTNUT ST. PHILA. PA.

# HERRING'S SAFES FOR JEWELERS,

IMPROVED AND PATENTED.

Medals Awarded  
AT  
International Exhibitions:  
1851.  
1853.  
1867.  
1876.  
1878.  
1879.  
1880.

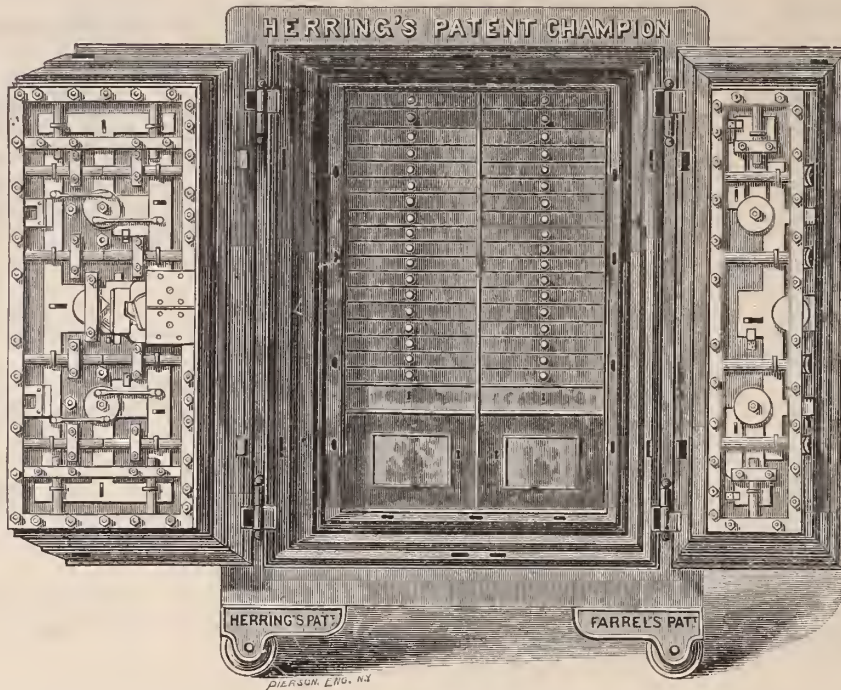

The HERRING  
SAFE & LOCK WORKS,  
372 to 381 South St.  
AND  
310 to 322 Front,  
250 Front on the East  
River,  
The Largest in the World!

It is of the first importance that the valuable goods in the hands of jewelers should be protected by secure safes. Purchase the best. **HERRING'S PATENT CHAMPION SAFES** are made to answer every requirement, and the leading manufacturing, wholesale and retail dealers in the Jewelry Trade are supplied with them, and others should be, to avoid the loss by fire or robbery.

**HERRING & CO., 251 & 252 Broadway, New York.**

# VIOLANES DU CAP.



## E. E. KIPLING

Desires to call the attention of the Trade to a NEW STONE, produced from a mineral hitherto little known. The stone is of a magnificent violet color, reflecting brilliant vibrating ruby rays and assuming the color of deep Oriental Ruby by artificial light. In hardness it equals the Rock Crystal. It is susceptible of the highest polish, and on account of these qualities must become most highly appreciated. Annexed is an analysis of the Mineral, by L. MAICHE, PARIS.

All further information concerning the above Stone, OF WHICH WE HAVE THE ENTIRE CONTROL, can be obtained at our office.

6 MAIDEN LANE, NEW YORK.

### ANALYSIS OF THE VIOLANE DU CAP

Made by L. MAICHE, Chemist, Civil Engineer, and Officer of the Academy, Paris.

|                                |       |
|--------------------------------|-------|
| Alumina.....                   | 64.20 |
| Magnesia.....                  | 31.00 |
| Silica.....                    | 2.00  |
| Iron and Manganese, about..... | .80   |
| Loss.....                      | 2.00  |

100.00

**SPECIFIC GRAVITY 2.95 to 3.06.**

From the physical and chemical analysis which I have made of this stone, I have concluded that if it can be obtained of a size and purity sufficient to be cut, it is entitled to be classed by Jewelers among the stones of the first order.

(Signed) L. MAICHE.

Paris, Feb. and March, 1883.

# MUTUAL RESERVE FUND

## LIFE ASSOCIATION.

HOME OFFICE, 55 LIBERTY ST., NEW YORK.

Furnishes Life Insurance at Less  
than one-half the usual rates.

**20,000 MEMBERS.**

**\$90,000,000 BUSINESS.**

**\$250,000.00 SURPLUS.**

**\$600,000.00 LOSSES PAID.**

**\$100,000.00 DEPOSITED with INS. DEP'T of N. Y.**

**P**ROMPT,  
**P**RUDENT,

**P**ROGRESSIVE,  
**P**OWERFUL.

**E. B. HARPER, Pres.**

**Central Trust Company, Trustee.**

ESTABLISHED 1869.

---

THE  
JEWELERS' CIRCULAR

AND

HOROLOGICAL REVIEW.

The Recognized Organ of the Trade.

---

SUBSCRIPTION, \$2.00 PER ANNUM.

---

PUBLISHED BY

*The Jewelers' Circular Publishing Company,*

SETH W. HALE, President,

42 NASSAU STREET,

NEW YORK.

# AIKIN, LAMBERT & CO.

23 MAIDEN LANE, NEW YORK,

MANUFACTURERS OF



GOLD PENS,

HOLDERS,

PENCILS,

TOOTH PICKS,

AND

LATEST

"NOVELTIES."

NEW AND ATTRACTIVE STYLES FOR FALL AND HOLIDAY TRADE.

— ALSO —

## ❖ JEWELRY. ❖

A Large Assortment of all Leading Styles in GOLD, SILVER and ROLL PLATE, including

- |                   |                        |
|-------------------|------------------------|
| <i>Diamonds,</i>  | <i>Buttons,</i>        |
| <i>Bracelets,</i> | <i>Studs,</i>          |
| <i>Rings,</i>     | <i>Lace Pins,</i>      |
| <i>Chains,</i>    | <i>Drops and Sets,</i> |
| <i>Charms,</i>    | <i>Scarf Pins,</i>     |
| <i>Locketts,</i>  | <i>Emblems,</i>        |
|                   | <i>Thimbles, Etc.</i>  |

## ❖ WATCHES. ❖

PAUL BRETON

Fine Movements, In Gold Cases.

AGASSIZ AND LONGINES

Stem Winding Movements, Fitting American Cases.

CHRONOGRAPHS, in Silver and Gold Cases.

Reliable Swiss Silver and Nickel Stem Winders.

ALL LEADING AMERICAN MOVEMENTS AND CASES.

Branches: } 113 EAST MADISON STREET, CHICAGO, ILLS.  
 } 20 ARCADE, CINCINNATI, O.

Factories: } 14, 16 & 18 MAIDEN LANE, N. Y.  
 } 12 VESEY AND 6 BARCLAY ST., N. Y.

❖ Novelties Continually Being Introduced. ❖

SELECTION PACKAGES SENT.

PROMPT ATTENTION TO ORDERS AND REPAIRS.

# IT IS USELESS

**F**OR A RETAIL JEWELER to think of doing business without a stock of American Movements; might just as well try to run water up hill. The majority of the people have their "eyes open" as to the different grades, in fact they are getting so well posted that it takes a smart Retailer to figure out any profit whatever on the average American Watch.

The FREDONIA WATCHES are sold direct to Retail Dealers in Watches only. To such the Company give the exclusive agency. They issue no price lists and thoroughly protect their agents.

The FREDONIA WATCHES have important improvements; they are built on scientific principles; they run close and can be depended on. Just now is a splendid time to have some sent on memorandum. The Leading Jewelers are pushing these goods from the fact that they run well, have a fine appearance and allow a profit.

We have appointed Messrs. **AIKIN, LAMBERT & CO.**, No. 23 Maiden Lane, New York, our **SOLE AGENTS** for the Eastern and Middle States, and **GENERAL SELLING AGENTS** for all the other States and Territories, except Illinois, Wisconsin, Iowa, Minnesota, Nebraska and Michigan, of which States Messrs. **STEIN & ELLBOGEN**, No. 123 State Street, Chicago, are **SOLE AGENTS**.

## FREDONIA WATCH COMPANY, Fredonia, New York.

# "BOOM" YOUR BUSINESS

WITH THE AID OF THE

## FRANCIS ENGRAVING MACHINE.

With the **Francis Engraving Machine** any Jeweler, with a few hours' practice, can do all his engraving, and do it better than the work commonly done by expert hand engravers. He can do this work in one-fifth the time necessary for hand work, and without the possibility of making any mistake.

We have on file many letters from Jewelers now using our Engraving Machine, to the effect that they have greatly enlarged their business, in some cases doubled it by reason of the work done by our Engraver. This they have accomplished by gratuitously engraving names, initials, monograms, emblems, etc., on jewelry, silverware, glass ornaments, etc.

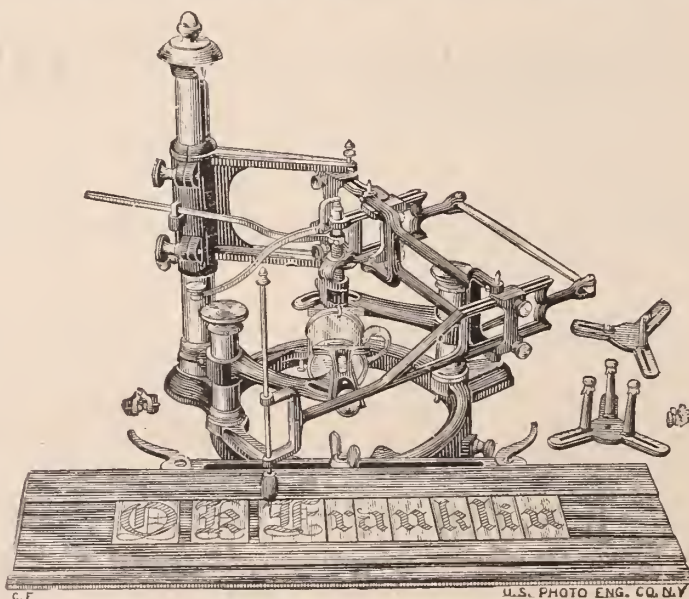

The Francis Machine will do perfect engraving on anything of metal kind, glass, ivory, bone or any other hard substance; the shape of the object is immaterial. It will engrave the inside of a finger ring, the bottom of a cup, the rounded surface of a napkin ring, a glass toilet set, anything that can be done by hand, and many things that a hand engraver cannot do in consequence of difficulty in getting at the work.

Full particulars, with circulars, a long list of references and special commendatory letters from persons using the machine, will be sent to any address on application to the general office of the

## FRANCIS ENGRAVING CO.,

19 PARK PLACE,

NEW YORK.

**"The Waterbury."**

**THE NEW "SERIES C,"**

**With FULL DIAL and SOLID PLATES.**



**NEW SERIES C.**  
Solid Plates and Full Dial.

With each series we have greatly improved the quality of the Watch, and are fully satisfied that "Series C" will be admitted by Dealers generally to be a decided step in advance.

The past three years' experience has enabled us to make the decided improvement so well known and acknowledged by those who have handled the Waterbury since its first introduction.

The "Series A" had open dial and skeleton plates. Our judgment in making the change in "Series B" to full dial and solid plates has received the unanimous verdict of approval, and we have retained them in "Series C."

The metal of the cases of "Series C" will be of Nickel Silver, which always wears white and clean.

Having found the Satin Lined Spring Box admirably adapted for safe transportation of Watches, we shall pack "Series C" in same box.

Material in any desired quantity can be had of New York office only.

**ONE THOUSAND WATCHES MANUFACTURED EVERY WORKING DAY.**

SERIES C.—Full Dial, Solid Plates, - - - \$48.00 per dozen.

**Discount to the Trade.**

Orders for less than one dozen are referred to the nearest Jobber. **We do not fill them.**

**Waterbury Watch Co., Waterbury, Conn.**

**NEW YORK OFFICE, 52 MAIDEN LANE.**

GEO. MERRITT, GENERAL SELLING AGENT,

To whom all Orders and Correspondence as to Prices and Terms should be addressed.

**FOR SALE BY DEALERS GENERALLY.**

**JOHN BLISS & CO.,**

**Standard Marine**

**CHRONOMETERS AND TRANSITS**

**FOR WATCHMAKERS' USE.**

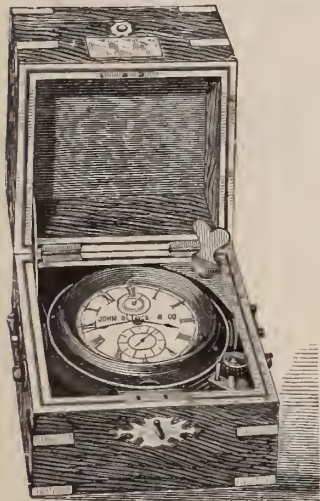

Standard Marine Chronometer,  
FOR KEEPING CORRECT TIME.

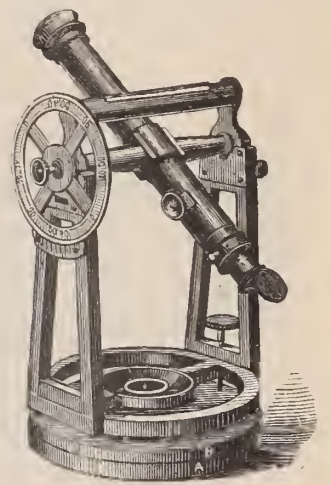

No. 10.

**128 FRONT STREET,**

**Near Wall Street,**

**NEW YORK.**

**NOTICE.**—These Transits are readily set in position without the aid of strictly correct time as a basis for that purpose. Printed instructions, easily understood, accompany each Instrument, and no calculations are required preliminary to setting in position.

SEND FOR ILLUSTRATED CIRCULAR WITH PRICES.

# NEW YORK OPTICAL CO.'S

## Patent EUREKA INTERCHANGEABLE Spectacles and Eye-Glasses.



**IN GOLD, SILVER, GERMAN SILVER AND STEEL.**

Completely INTERCHANGEABLE in all its parts.

The **Loops** of the eye-frames can be enlarged or contracted at will, so that lenses of various sizes may be made to fit tightly in the same frame, thus securing an **Interchange of Lenses**.

The joints or end pieces are made of a slender solid piece of metal and are so constructed that the **Temples** can be easily detached from one frame and freely adjusted to any other, thereby securing the **Interchange of Temples**.

Should the temples become loose through wear, they may be easily tightened by the aid of a screw driver.

**THE SIMPLICITY AND SOLIDITY OF CONSTRUCTION,  
LIGHTNESS OF WEIGHT AND INTERCHANGEABLE QUALITY,**

render them exceedingly desirable goods for Dealers to handle, and certainly the most satisfactory to the general wearer, while the price cannot fail to attract the attention of Dealers.

For Sale at Manufacturers' Prices by the following  
Jobbers:

**Chicago:** H. F. Hahn, & Co., 157 State St.

" Clapp & Davies, 63 Washington St.

" J. P. Bieber, 152 La Salle St.

**New Orleans:** Koch & Dreyfus, 18 Chartres St.

**Galveston, Tex.:** M. W. Shaw, Tremont & Market Sts.

**St. Louis:** H. Hirschberg Optical Co., 107 N. Fourth St.

" Massa, Lewis & Co., 210 N. Fourth St.

**Pittsburg, Pa.:** Chas. Zugsmith, Jr., Wood St. and Sixth Ave.

**New York City:** Friedenthal & Rypinski, 43 Maiden Lane.

" " I. Fargeon, 77 Nassau St.

" " John Scheidig & Co., 43 Maiden Lane.

" " B. F. Cahn, 6 Maiden Lane.

**Boston, Mass.:** M. Myers, 299 Washington St.

**Cincinnati:** John A. Awalt, 173 Vine St.

## PATENT IMPROVEMENT IN COUNTER + SHOW + CASES, WITH PERPENDICULAR SLIDING DOORS. DUST PROOF.

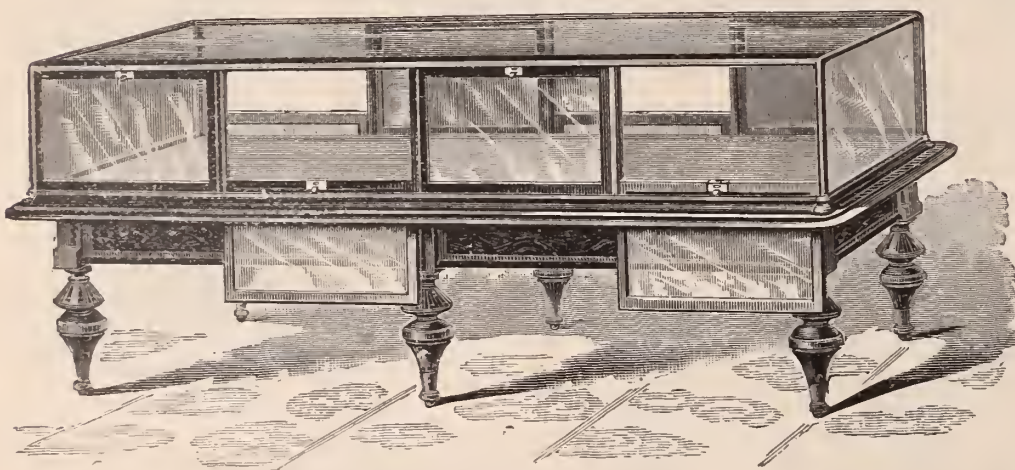

The Advantage and Convenience of these Show Cases will be apparent to everyone.

The doors are more conveniently opened and closed, less liable to get out of repair or broken, articles are more easily reached in wide cases, mirrors are more safe, it dispenses with hinges, economizes room, excludes dust, and is air tight when closed.

Drawings furnished and estimates given for fitting stores in cabinet work complete.

Letters Patent having been granted us for the construction of these doors, we shall prosecute all parties using Cases which infringe on our Patents.

REFERENCES:—Gorham Mfg Co., Rogers & Bro., Mitchell Vance & Co.,  
Meriden Britannia Co., M. S. Smith & Co., Detroit, Mich.  
D. Valentine, Syracuse, N. Y.

**B. & W. B. SMITH,**  
**220 West 29th Street, New York.**

M. Anderson, No. 57 State Street, Chicago, has the exclusive right to manufacture and sell our Improved Cases for the States of Wisconsin, Illinois, Missouri, Mississippi, Arkansas, and all States West of same.

CATALOGUE OF STYLES SENT ON APPLICATION.





Watchmaking in 1784.

# WHITCOMB LATHE.

2160 SOLD.

SOLD BY ALL JOBBERS.

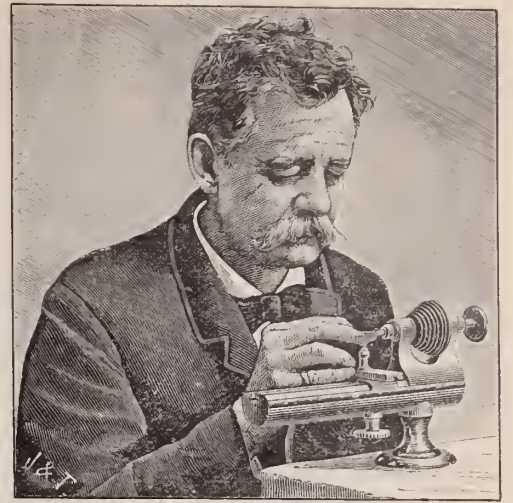

Watchmaking in 1884.  
WHITCOMB AND HIS LATHE.

Send for our Catalogue and Price List for 1884, which contains, in addition to the List of our own Tools, interesting and valuable facts relating to the Watch Factories.

## AMERICAN WATCH TOOL CO., WALTHAM, MASS.

WESTERN OFFICE, 31 WASHINGTON STREET, CHICAGO, ILLS.

### STANDARD DUST-PROOF WATCH KEYS.

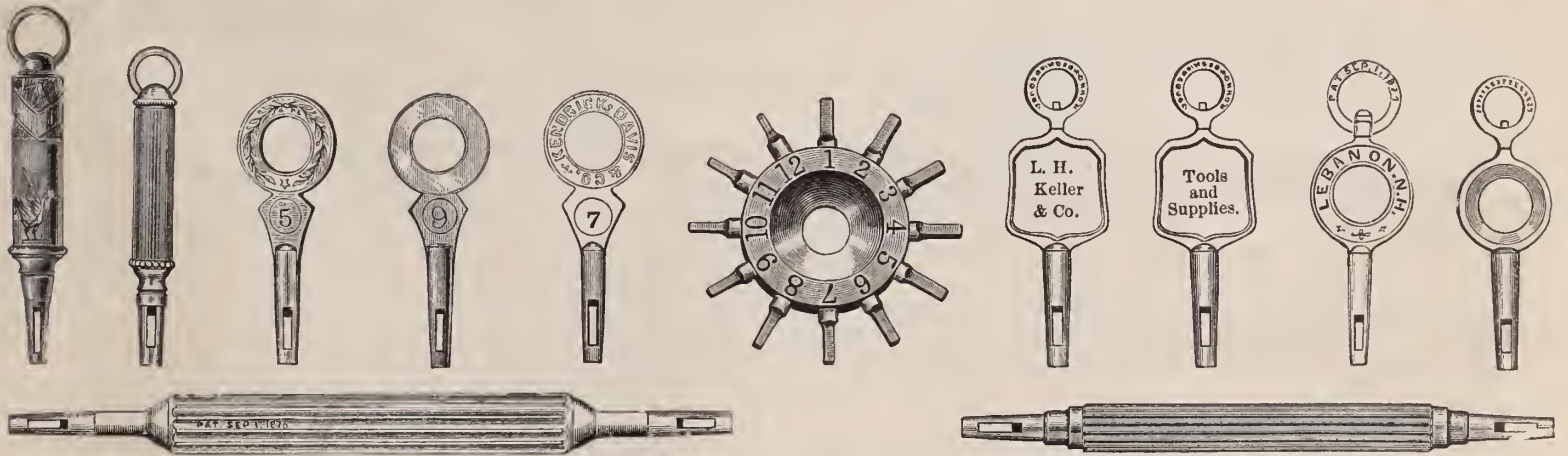

FOR SALE BY



THE TRADE.

# KENDRICK & DAVIS,

Sole Owners and Manufacturers, Lebanon, N. H.

ILLUSTRATED CATALOGUE and PRICE LIST SENT ON APPLICATION.

# Spencer Optical Manuf'g Co.

ARE MAKING MANY  
NEW AND DESIRABLE STYLES  
FOR THE  
EARLY FALL TRADE.  
BETTER FINISH.  
PRICES THE LOWEST.

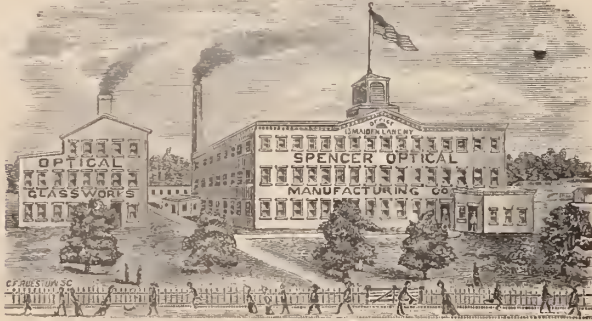

Great Reductions in Rubber Eye-Glasses.  
GREAT REDUCTIONS ON PEBBLES.

The Most Perfect Pebble Tester ever made. Works Instantaneous.  
No directions required. Price, \$1.50 half the price of  
Common Imported Testers.

Our GOLD GOODS are Unsurpassed for  
Beauty, Durability and Finish.  
QUALITY GUARANTEED.

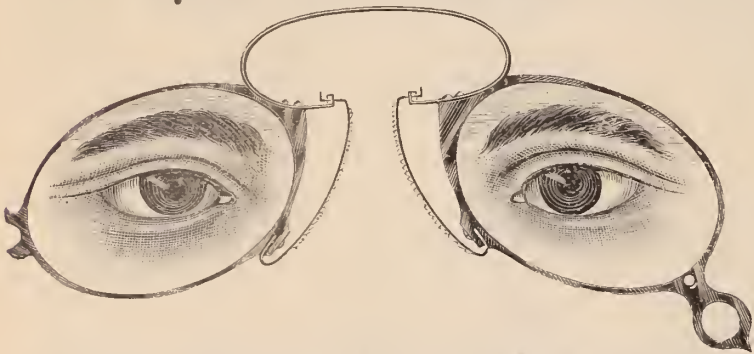

## CELLULOID SPECTACLES AND CELLULOID EYE-GLASSES

have made their own reputation and are universally popular wherever introduced.

**BEWARE OF IMITATIONS.**

If you wish a Specialty, call on us.

We make a SPECIALTY in SPECIAL GOODS for the FINE RETAIL TRADE, which gives customers handling our goods IMMENSE ADVANTAGE over all others, each dealer having a Specialty of his own, thereby destroying the ruinous competition which exists in many cities at the present day.

**QUALITY OF GOLD GUARANTEED.**

We are importing large Invoices of Opera, Field and Marine Glasses in Staple and Novel Designs.

Catalogue sent on receipt of Business Card.

Spencer Optical Manufacturing Co.,  
113 MAIDEN LANE, NEW YORK.

Established 1853.

# L. H. KELLER & CO.

Successors to G. A. HUGUENIN,

IMPORTERS OF

WATCHMAKERS' and JEWELERS'  
TOOLS AND MATERIALS.

GENERAL AGENTS FOR

The Philadelphia Watch Company,

— AND —

American Watch Tool Co.,

MANUFACTURERS OF

THE WHITCOMB LATHE.

SOLE AGENTS IN THE UNITED STATES FOR THE SALE OF

**LUTZ'S**  
CELEBRATED ROLL HARDENED HAIR SPRINGS,  
**MOEBIUS OIL**

For Chronometers, Watches, Clocks, Telegraph Instruments and all other delicate machinery. Made from Pure Refined Neatsfoot Oil, and Warranted to Excel anything in the market as a Lubricator. SAMPLES GRATIS.

**OUR OWN GRADUATED**

AND JURGENSEN RECOILING MAINSPRINGS, pronounced by all experts Superior to all. Sold in Separate Strengths or Force.

Extra Fine Pinions cut from Solid Steel Wire. Gauged Hole Jewels of First-class Workmanship. A Full Line of Materials, for the PATEK, PHILIPPE & CO. GENEVA WATCHES, and all other Celebrated Makers.

## THE BOLEY LATHES AND TOOLS,

Celebrated for their Practical, Substantial and Workmanlike Construction, Superior Design and Finish.

*Our aim is to furnish nothing but First-class Serviceable Goods, especially manufactured for the Consumer, and not solely for the Market, like the cheap trash advertised in highly illustrated catalogues with which the country is flooded.*

**TREATISE ON MODERN HOROLOGY IN THEORY AND PRACTICE.** By M. CLAUDIUS SAUNIER, Ex-Director of the School of Horology at Macon, France; Knight of the Legion of Honor, etc.; Hon. Sec. to the Paris Society of Horologists. Translated from the French by JULIEN TRIPPLIN, Besançon Watch Manufacturer, and EDWARD RIGG, M. A., Assayer in the Royal Mint, London.

This Work comprises 832 large octavo pages, with 78 wood cuts and 21 colored double-page copper-plate engravings. Bound in half calf, with an appropriate and handsome ornament in gold on front cover.

**Price, \$15.00.**

**THE WATCHMAKER'S HAND BOOK.** By the same author and translators. Intended as a companion to the Treatise. Bound in cloth.

**PRICE, \$4.00.**

**64 Nassau Street,**

NEAR MAIDEN LANE,

**NEW YORK.**

L. H. KELLER,  
EDWARD HUNZIKER,  
F. J. BOESSE.

We do not publish Price Lists.

# SOMETHING NEW!

## The Giles' Patent Anti-Magnetic Shield

### NOW READY FOR THE MARKET.



The application of Anti-Magnetic Shields to pocket timepieces promises to be of very great importance to horologists and watchmakers; it will render operative the fine adjustments and mechanisms which hitherto have been made almost nil and inoperative on account of their susceptibility to the all-pervading magnetic influences. The advantages of magnetic-proof watches are many and very important.

- 1st. Protection against personal magnetism.
- 2d. Protection against electric currents which induce magnetism—magnetic belts and other personal electric appliances.
- 3d. Protection against magnetism caused by dynamo-machines, electric wires, the multiplied electric and magnetic devices of the present day, which places any one in daily danger of coming within their influence and having their watches affected thereby.
- 4th. A protection for railroad men, who are constantly under the influence of electricity and magnetism caused by the moving train.
- 5th. A protection for machinists, who are brought under the magnetic influence caused by the running machinery, belts, etc.
- 6th. Protection for breaking mainsprings caused by the so-called electric storms, or magnetic influences of the atmosphere.
- 7th. A dust-proof case keeps the watch in much better order, the oil fresh and clean, thereby reducing the friction, giving better time, and rendering the watch more durable.



SEND FOR DESCRIPTIVE CIRCULAR.

**GILES, BRO. & CO., CHICAGO.**

## BIRCH'S PATENT SELF-ADJUSTING WATCH KEYS.

**FOR SALE BY THE TRADE GENERALLY.**



**2.—POCKET KEY.**  
(Brass.)



**3.—POCKET KEY.**  
(Nickel Plated.)



**7.—BENCH KEY.** (Brass Handle.)



**4.—POCKET KEY.**  
(Nickel Plated, Hexagon Shell.)



**5.—POCKET KEY.**  
(Heavy Rolled Gold Plate Mountings.)

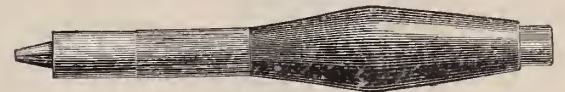

**8.—SHORT WOOD HANDLE KEY.**  
(Nickel Plated, for Bench or Pocket Use.)



**6.—CELLULOID MOUNTED KEY.**  
(With Heavy Rolled Gold Plate Tips.)



**35.—POCKET KEY. CELLULOID MOUNTINGS.**  
(Imitation Malachite, with Extra Heavy Rolled Gold Plate Tips. 18. K.)



**9.—LONG WOOD HANDLE BENCH KEY.** (Nickel Plated.)

MADE IN 37 STYLES.

CIRCULARS ON APPLICATION.

**J. S. BIRCH & CO., 38 DEY STREET, NEW YORK.**

## The American Pebble Spectacles & Eye-Glasses

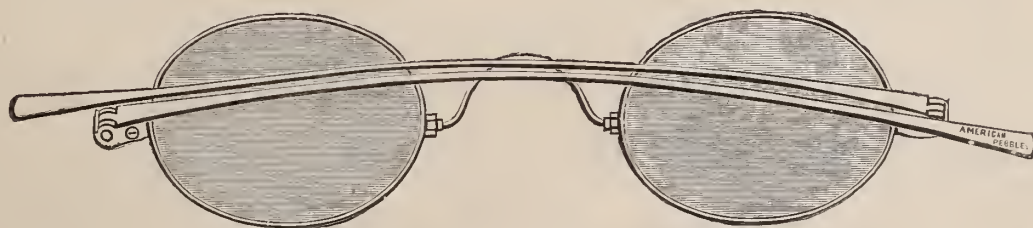

**The Most Popular and Easy Selling Optical Goods ever introduced.**

Agents wanted in every town and city to handle these goods, to whom we will give the control and offer special inducements. For all information apply to

**AMERICAN PEBBLE SPECTACLE CO., 66 Nassau Street, N. Y.**

# Spencer Optical Manuf'g Co.

MAKERS OF  
NOVELTIES IN OPTICAL GOODS.

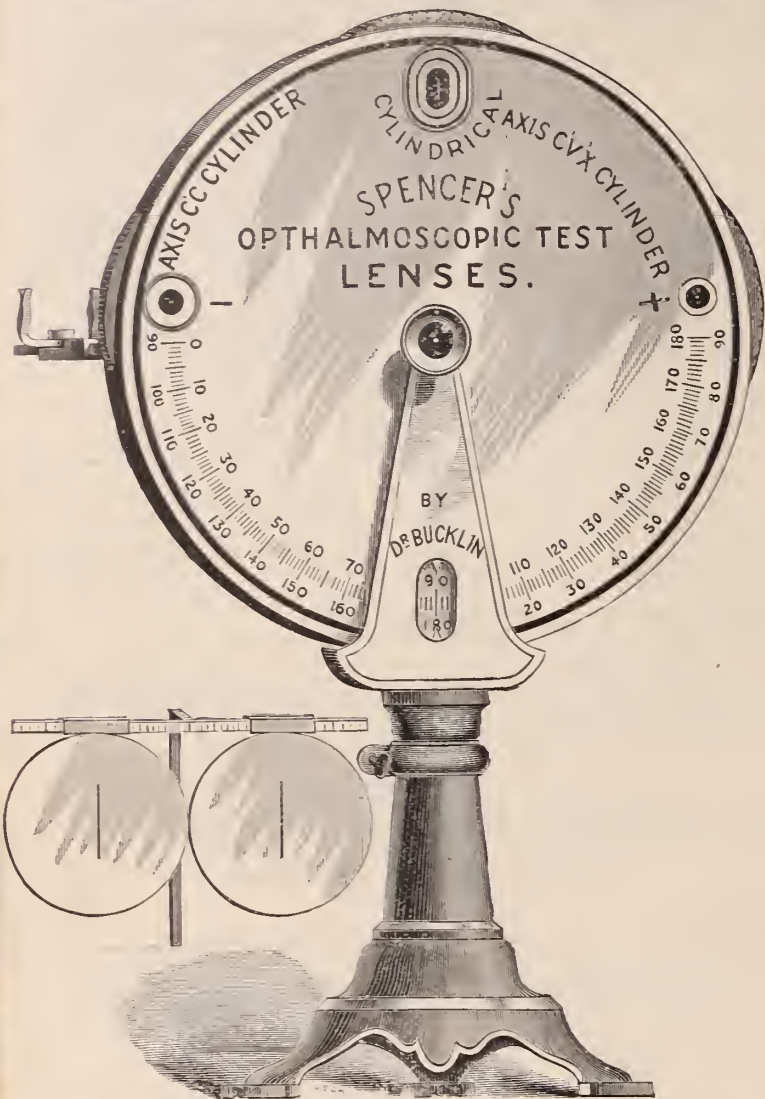

We now offer to the Jewelers and Opticians our new **Ophthalmoscopic Test Lens**. We have 500 in actual use and can recommend it as being a Scientific and Thoroughly Practical Instrument of detecting all optical defects and determining the lenses needed for their correction, and with a little study and investigation most any person can learn how to correct any visual imperfection.

This Instrument measures each eye separately, which all Oculists agree is the best method. It is simple in its construction and easily understood.

SEND FOR CIRCULAR.

Our New Pebble Tester, one of the most useful articles known in the Optical line, works instantaneously and warranted correct.

## SPENCER OPTICAL MANUFACTURING CO.,

MANUFACTURERS OF

### Optical Lenses,

Gold, Silver, Steel, Nickel, Celluloid,  
Rubber and Plated

### SPECTACLES AND EYE-GLASSES.

IMPORTERS OF

OPERA, FIELD AND MARINE GLASSES.

Salesroom, 13 Maiden Lane, New York

FACTORIES, Mt. KISCO, N. Y.

Established 1853.

# L. H. KELLER & CO.

Successors to G. A. HUGUENIN,

IMPORTERS OF

WATCHMAKERS' and JEWELERS'

## TOOLS AND MATERIALS.

GENERAL AGENTS FOR

The Philadelphia Watch Company,

— AND —

American Watch Tool Co.,

MANUFACTURERS OF

### THE WHITCOMB LATHE.

SOLE AGENTS IN THE UNITED STATES FOR THE SALE OF

### LUTZ'S

## CELEBRATED ROLL HARDENED HAIR SPRINGS, MOEBIUS OIL

For Chronometers, Watches, Clocks, Telegraph Instruments and all other delicate machinery. Made from Pure Refined Neatsfoot Oil, and Warranted to Excel anything in the market as a Lubricator. SAMPLES GRATIS.

### OUR OWN GRADUATED

AND JURGENSEN RECOILING MAINSPRINGS, pronounced by all experts Superior to all. Sold in Separate Strengths or Force.

Extra Fine Pinions cut from Solid Steel Wire. Gauged Hole Jewels of First-class Workmanship. A Full Line of Materials, for the PATEK, PHILIPPE & CO. GENEVA WATCHES, and all other Celebrated Makers.

### THE BOLEY LATHES AND TOOLS,

Celebrated for their Practical, Substantial and Workmanlike Construction, Superior Design and Finish.

*Our aim is to furnish nothing but First-class Serviceable Goods, especially manufactured for the Consumer, and not solely for the Market, like the cheap trash advertised in highly illustrated catalogues with which the country is flooded.*

**TREATISE ON MODERN HOROLOGY IN THEORY AND PRACTICE.** By M. CLAUDIUS SAUNIER, Ex-Director of the School of Horology at Macon, France; Knight of the Legion of Honor, etc.; Hon. Sec. to the Paris Society of Horologists. Translated from the French by JULIEN TRIPPLIN, Besançon Watch Manufacturer, and EDWARD RIGG, M. A., Assayer in the Royal Mint, London.

This Work comprises 832 large octavo pages, with 78 wood cuts and 21 colored double-page copper-plate engravings. Bound in half calf, with an appropriate and handsome ornament in gold on front cover.

Price, \$15.00.

**THE WATCHMAKER'S HAND BOOK.** By the same author and translators. Intended as a companion to the Treatise. Bound in cloth.

PRICE, \$4.00.

## 64 Nassau Street,

NEAR MAIDEN LANE,

NEW YORK.

L. H. KELLER,  
EDWARD HUNZIKER,  
F. J. BOESSE.

We do not publish Price Lists.

**SPECIAL NOTICES.**

**Notices under this Heading, not to exceed Six Lines, \$1.00 each insertion.**

Advertisers having letters addressed in care of this office, must inclose postage for answers forwarded.

**WATCH WHEELS** of every description. S. Millard, No. 6 John street, N. Y.

**WANTED**—A good watch repairer, one who can engrave. Address W. G. Martens, Rochester, N. Y.

**WANTED**—Curiosities in horology. Anything really curious, ancient or modern. Address with full description and price, Lock Box B., Waterbury, Conn.

**ENGLISH, Swiss and American watches** altered from key to stem winding. Lowest prices consistent with fine workmanship. S. Millard, No. 6 John street, N. Y.

**SITUATION** wanted by a watchmaker and jeweler. Over seventeen years' experience. Good reference. N. Y. State preferred. Address S. M. V. A., care Jewelers' Circular.

**WANTED**—A good watchmaker and jeweler; to the right man a permanent situation will be given; must have good recommendations. Address F. E. Copewell, Farmington, Conn.

**WANTED**—A situation by a watchmaker who understands watch and French clock repair. g. References given. For particulars address S. A. W., Lock Box 285, Brattleboro, Vt.

**THEO. LESPÉRANCE**, No. 1 Maiden Lane, New York, watchmaker and wheel cutter. Changing watches from key to stem winding a specialty. A large stock of diamond and gothic hands constantly on hand.

**WANTED AT ONCE**—An industrious young man to learn the watchmaking and jewelry business. Would prefer a hand of a little experience. Good reference required. Address F. A. Morgan, Lebanon, N. H.

**WANTED**—The addresses of all traveling dealers in watch materials, etc., to introduce an easily selling and well paying novelty. Communications will oblige H. B., care Editor Jewelers' Circular, 42 Nassau St., N. Y.

**MOSELEY & CO.**, Elgin, Ill., manufacturers of the "Moseley" Lathe, with full line of fixtures and attachments. Designed especially for the watchmaker and repairer. Combining accuracy, durability, convenience and style.

**FOR SALE**—Vols. 7, 8, 9, 10, 11, 12, 13 and 14 of The Jewelers' Circular. Neatly bound in cloth with morocco back and corners. Containing all of the second series of "Practical Hints" by Excelsior. Address A. J. Green, Grafton, Neb.

**\$1,000** to \$1,500 will buy the only jewelry store in a central Illinois town of 3,500 inhabitants. Splendid run of work. Elegant store room and living rooms combined. Rent very low. Will sell on easy terms. Address Lock Box 90, Urbana, Ill.

**WANTED**—Experienced traveling salesmen to carry on commission small sample lines of salable goods handled by the jewelry and kindred trades, either separately or in conjunction with other lines, such as clocks, gold pens, silverware, etc. Address D., care Jewelers' Circular.

**WANTED**—Watch and jewelry repairer; hard solder, etc. Young man under 35. Also must clerk in jewelry and book store. Wages moderate. Satisfactory references to ability, character and honesty. To right man situation is permanent. Address Lowell, Box 388, Birmingham, Conn.

**GEORGE E. WILKINS**, manufacturer and importer of cutters for watchmakers' use, stem-winding cutters of all the different forms, rounding up cutters of the finest quality, also ratchet cutters. A large stock of second hand and new marine chronometers. No. 21 South Salina street, Syracuse, N. Y.

**FOR SALE**—First-class jewelry store in town of 8,000 population and thickly settled country around. Leading store of the place in stock and trade. Will invoice stock and fixtures about \$5,000. Reasons for selling are not a practical jeweler and want to move west. Address C. C., care Jewelers' Circular.

**WANTED**—Situation by a young man desirous of finishing his trade. Have had little over one year's experience. Can do ordinary clock and jewelry repairing and engraving. Good habits and reference. Prefer to go on trial for short time before making permanent arrangements. Address Steve Davies, Remsen, N. Y.

**WANTED**—A situation as fine watchmaker. Have a fine set of tools and am familiar with fine watch adjusting and repairing of all kinds. Have had fifteen years' experience at the bench, and can furnish the highest references as to character and ability. Some large city preferred. Address O. Lever, care Jewelers' Circular.

**FOR SALE**—The leading jewelry store in the largest city in the oil country, 10,000 inhabitants. The store is in a brick block, plate glass front and handsomely fitted up. Plenty of work for two men. Only two jewelry stores in the place. Stock will be reduced to suit customer. Good reasons given for selling. Address A. Y. X., care Jewelers' Circular.

**TUBING** of every description drawn to order at short notice. Gold pen, pen and pencil cases, novelties, tooth picks, at lower prices than can be purchased elsewhere. Sample line sent on approval to approved parties. Gold pens re-pointed, repaired, exchanged. Ray Manufacturing Company, salesroom and factories, 94 & 96 Nassau St. and 129, 131 and 133 Fulton St., New York.

**TO THE TRADE**.—I make a specialty of supplying the Trade with stones for jobbing purposes. Parties having jewelry out of which the stones have been lost, sending their orders by mail or express, will have them promptly attended to. A large stock of cameos, pearls, turquoise, garnets, amethysts, doublets, foilbacks, white and colored imitation stones on hand. All kinds of setting done for the Trade. W. Archibald, 73 Nassau street, New York.

**FOR SALE**—Stock and fixtures of leading jewelry store at South Bend, Ind. Will reduce stock to nearly any amount desired and give immediate possession. Have occupied store for ten years; business during that time has averaged \$1,000 monthly; labor about \$100 per month. Best advertised store in Co. and none in the land has a better reputation for honorable dealing. Refer to Mess. C. G. Alford & Co and Mess. Marx & Weis of New York. Hight & Fairfield, South Bend, Ind.

**FOR SALE**—1 No. 1 Moseley (hard) watchmakers' lathe with attachments, including universal head, swing rest with calliper and lateral screw, slide rest, pivot polisher, counter shaft, face plate, screw plate and top, 50 chucks, split; 5 wheel; emery laps, diamond laps, copper, ivory and tortoise shell laps and grinders, spotting and snalling grinders, tapers, cutters for slide rest, extra spindles, etc. Been in use 6 months. Have two of same make. Cost about \$350. Will sell for \$250. Address F. Gilmore, 16 Maiden Lane, care Jno. Ward.

**FOR SALE**—The stock, fixtures, good will and lease of the "Diamond Palace," the leading, prettiest and oldest established jewelry store in Leadville, Colo. Population 18,000. Will reduce stock to suit purchaser, ask nothing for good will and a splendid lease, as must positively get out of the jewelry business by January 10, 1885, and are willing to make big sacrifice to do so. Reasons made known to purchaser. This is indeed a rare chance for anybody. For further particulars address Dan G. Golding, P. O. Box 990, Leadville, Colo.

**FOR SALE**—A first-class jewelry store in one of the best towns of Central Pennsylvania of over 2,000 inhabitants. Great manufacturing town and a large country trade; has a good run of bench work and doing a general good business. Store is located in the best town; plate glass front and finely furnished inside; dwelling under same roof; stock of fixtures will inventory about \$3,000; will sell to suit buyer, either the whole or part, or fixtures and material without stock. A long lease can be had for store room alone or for house and store room. Good reasons for selling. For particulars, address Huston Jackson, Watsonstown, Pa.

**BUYERS' DIRECTORY.****NEW YORK.****Assayers and Sweep Smelters.**

**Wundoehl, H.**—Gold and Silver Refiner, Assayer and Sweep Smelter. 21 John Street, N. Y.

**Badges and Medals.**

**Frick, John & Co.**—Makers of Medals and Badges of all kinds. Also Manufacturers of Jewelry. Dealers in Fine Rolled Plated Goods, etc. 23 Maiden Lane, N. Y.

**Stockwell & Newman**—19 John Street. Manufacturers of Badges, Medals and Presentation Pieces in Gold and Silver. Also Jewelry and Mounters of Diamonds. Designs supplied.

**Band Rings.**

**Knapp, Charles**, 41 Maiden Lane, N. Y. Specialty: Superior Band Rings, also Ring Shanks & Heads for Seal and Diamond Rings.

**Black Onyx Jewelry.**

**Cox & Sedgwick**—Manufacturers of Black Onyx Jewelry, No. 26 John St. New York.

**Lawson, Samuel**—No. 18 John Street. Manufacturer of Black Onyx Jewelry. Coral repaired for the trade. Goods sent on approval to responsible dealers.

**Woglom & Miller**—Manufacturers of (exclusively) Black Onyx Jewelry, 32 & 34 John St., N. Y.

**Blue Enameled Lockets.**

**Bissinger, Philip & Co.**—Importers of Diamonds, Pearls and Precious Stones. Agent for the Bohemian Garnet Goods. Blue Enameled Lockets and Coral Goods. 22 John St., N. Y.

**Emrich, I.**—Importer of Blue Enameled Lockets, Ear Drops and all kinds of Enameled Jewelry; also Enamel for Manufacturing purposes, 66 Nassau St., N. Y.

**Bohemian Garnet Jewelry.**

**Bissinger, Philip & Co.**—Importers of Diamonds, Pearls and Precious Stones. Sole Agent for the Bohemian Garnet Jewelry. Blue Enameled Lockets and Coral Goods. 22 John St.

**Emrich, I.**—Importer of Half Pearls and Bohemian Garnet Jewelry. Designs made to order in our European Factory at moderate prices. 66 Nassau St., N. Y.

**Clock Companies.**

**Ansonia Clock Co.**—Manufacturers of every description of Clocks. 11 to 21 Cliff street, New York.

**E. Howard Watch and Clock Co.**—No. 29 Maiden Lane, New York, and 114 Tremont St., Boston.

**Kroeber, F.**—Manufacturer and Dealer in American and French Clocks. No. 14 Cortlandt Street.

**Le Boutillier & Co.**—Importers and Jobbers in French Marble Clocks. 31 and 33 West 23d Street, N. Y.

**New Haven Clock Co.**—16 and 18 Park Place, N. Y.

**Seth Thomas Clock Co.**—20 Murray Street, N. Y.

**Waterbury Clock Co.**—Manufacturers, No. 10 Courtlandt St., N. Y. and No. 63 Washington St., Chicago, Ills.

**Welch, E. N., Manufacturing Co.**—Manufacturers of American Clocks. No. 6 Warren St.

**Wm. L. Gilbert Clock Co.**—No. 6 Murray Street, Manufacturers of Clocks. Factories, Winsted, Conn.

**Cameo Cutters, Etc.**

**Peiter, Theodore**—Cameo and Intaglio Engraver. Patentee of the Cameo-Intaglio. No. 3 Maiden Lane, New York.

**Charms & Gold Watch Keys.**

**Rupp & Held**—Manufacturing Jewelers, Charms and Gold Watch Keys, with French and English Ratchets, a specialty. 15 John St., N. Y.

**Crucibles.**

**Berge, J. & H.**—Established 1850. Importers of Sand Crucibles, Covers, Chemical Porcelain, Glassware, and Jewelers' and Assayers' Supplies. 95 John Street, N. Y.

**Diamond Brokers.**

**Anderson, Otis**—Diamond Merchant and Broker, always ready to pay cash for bargains in Diamonds and Precious Stones, 4 & 6 John Street, N. Y.

**Friend S. & Son**—Brokers and dealers in Diamonds 33 John Street, cor. Nassau St. New York.

**Herbert, R. J.**—Diamond Broker and Dealer. 26 Maiden Lane.

**Diamond Importers.**

**Anrich, E. L.**—Diamonds, 182 and 184 Broadway, cor. John St. N. Y. Cutting Establishment, 133 Water St.

**Bernhard, A. & Co.**—Importers of Diamonds and Manufacturers of First-class Diamond Jewelry, Diamond Settings for Manufacturing Jewelers, Catalogue of Designs for the Trade free of charge. No. 2 Maiden Lane, New York.

**Bissinger, Philip & Co.**—Importers of Diamonds, Pearls and Precious Stones. Agent for the Bohemian Garnet Goods. Blue Enameled Lockets and Coral Goods. No. 22 John St., N. Y.

**Bruhl, D. & M.**—Established in 1848. 14 Maiden Lane, N. Y.; 111 Broad Street, Providence, R. I.; 14 Rue Bleue, Paris.

**Brunswick, S. & Co.**—Importers of Diamonds. 17 Maiden Lane, New York. Paris, Rue Lafayette. Amsterdam, Damsstraat.

**Citroen, L. B., & Co.**—Diamonds. 21 John St., N. Y. Cutting Works, 57 & 61 Rapenburgerstraat, Amsterdam. House in Paris, 53 Rue de Chateaudun.

**Faulkenau, Oppenheimer & Co.**—Manufacturers. Diamonds and Diamond Jewelry. 40 Maiden Lane, N. Y.

**Fera, Henry**—Importer of Diamonds, and Manufacturer of Fine Diamond Jewelry. 4 & 6 John Street, New York. Amsterdam, Holland, 23 Loojersgracht.

**Fox, M. & Co.**—Importers of Diamonds, Rubies, Sapphires and Fancy Gems. No. 1 Maiden Lane, New York

**Hedges, Wm. S. & Co.**—Importers of Diamonds. No. 170 Broadway, corner Maiden Lane.

**Henle Brothers**—Importers of and Wholesale Dealers in Diamonds only. No. 16 Maiden Lane, N. Y. Paris, 20 Rue Laffitte.

**Hessels, Anthony**—Importer and Dealer in all kinds of Precious Stones. Diamond Cutters and Polishers. 45 John Street, N. Y.

**Kuhn, Doerflinger, & Co.**—Manufacturing Jewelers and Importers of Diamonds, 18 John Street, New York

**Leberthon, L. M.**—Importer of Diamonds and Manufacturer of Fine Jewelry. 14 John Street, N. Y.

**Miller Bros.**—Importers of Diamonds and Manufacturers of Fine Diamond Jewelry and Mountings.

**Mulford & Bonnet**—Diamond Importers, No. 21 Maiden Lane, N. Y. City.

**Neresheimer, E. Aug. & Co.**—Importer of Diamonds. No. 21 Maiden Lane, New York.

**Randel, Baremore & Billings**—Importers of Diamonds, corner Maiden Lane and Nassau St.

**Saril, S.**—Importer of Diamonds, 182 Broadway, N. Y. Branch of Vve. H. A. Marchand & Frères, 47 Rue Le Peletier, Paris.

**Saunders & Ives.**—Importers of Diamonds and other Precious Stones. No. 26 Maiden Lane.

**Smith, Alfred H. & Co.**—Importers of Diamonds, No. 182 Broadway.

**Strauss, Jacob**—Importer of Diamonds and Dealer in Diamond Jewelry. 25 John Street.

**Tannenbaum, L. & Co.**—Importers of Diamonds and Precious Stones. Steam Lapidary Works. Oriental Stones Cut and Polished a specialty. 65 Nassau St., N. Y.

**Taylor & Brother.**—Importers of Diamonds and Diamond Jewelry. 860 Broadway.

**Wickham, D. H. & Co.**—Importer of Diamonds. No. 31 Holborn Viaduct, London, 24 Maiden Lane, New York.

**Wolf, G. A.**—Importer of Diamonds, Rubies, Sapphires, Pearls, and other Precious Stones, 65 Maiden Lane, New York. 12 Rue de Chateaudun, Paris.

#### Diamond Jewelry.

**Baldwin, Sexton & Peterson**—Importers of Diamonds and Manufacturers of Diamond Jewelry, 692 and 694 Broadway, N. Y.

**Bornemann, Louis.**—Importer of Diamonds and Manufacturer of Rich Diamond Jewelry, 19 John Street, New York.

**Chalumeau, D.**—Diamond Jeweler and Manufacturer of Mountings. Novelties and Artistic Jewelry. No. 3 Maiden Lane, New York.

**Goldsmith, Igomar & Co.**—Manufacturers of Diamond Mountings and Diamond Jewelry, 61 Nassau Street, New York.

**Goldsmith & Co.**—Manufacturers of Fine Diamond Mountings and Diamond Jewelry. Lace Pins, Ear Rings and Rings a specialty. 49 Maiden Lane, N. Y.

**Hartje, G. & F.**—Manufacturers of Diamond and Fine Jewelry, 39 Union Square, N. Y.

**Haug, John**—Manufacturer of Fine Diamond Mountings, etc. No. 130 Fulton St., N. Y.

**Heller & Bardel.**—Manufacturers of Diamond and Pearl Jewelry, and Dealers in Diamonds, Pearls, &c. 13 John Street.

**Jeanne Brothers.**—Manufacturers of Diamond Mountings & Rich Jewelry. 1 Maiden Lane.

**Lacroix & Verpillier.**—Manufacturers of Fine Gold Jewelry. Diamonds a specialty. 173 Broadway, N. Y.

**Luthy, A. & Co.**—Manufacturers of Fine Diamond Mountings, Lace Pins, Ear Rings, Rings, Knife Edge Bracelets, Hair Ornaments, etc., a Specialty. 35 Ann Street, corner Nassau Street, N. Y.

**Mitchell, Noah**—Manufacturer of Diamond Jewelry and Diamond Mountings. 52 Maiden Lane, New York.

**Nissen, Ludwig & Co.**—Dealers in Diamonds and Manufacturers of Diamond Mountings. No. 51 Nassau Street, New York, near Maiden Lane.

**Rosswog, C. & Son**—Manufacturers of Rich Diamond Goods. Nos. 5 and 7 Maiden Lane, N. Y.

**Stern & Karutz**—Manufacturers of Fine Diamond Mountings. Lace Pins, Ear Rings, Rings, Knife Edge Bracelets a Specialty. Orders by mail promptly attended to. 130 Fulton Street, Room 11, first floor, New York.

**Voelker, C. T.**—Manufacturer of 18-k. Diamond Mountings, Diamond Jewelry and Roller Chain Bracelets. 15 Maiden Lane, New York.

**Waterman & Lehmann.**—Manufacturing Jewelers and Dealers in Diamonds. Diamond Work, and Fine fancy Rings a specialty, any piece of single work made to order. 37 Maiden Lane, N. Y.

**Wienhold, J.**—Manufacturer of Fine Jewelry. Diamond Mountings a specialty. 24 John Street.

#### Diamond Cutters.

**Becker, Kohl & Co.**—Diamond Cutters and Polishers. Repairing and Matching a Specialty. 40 John Street, bet. Nassau and William, New York.

**Levy, Herman.**—Importer, Cutter and Polisher of Diamonds. 105 Fulton Street, New York.

**Mendes, D. De S.**—Diamond Cutter and Polisher, 113 Nassau St., N. Y. Re-cutting, Repairing and Matching a Specialty.

#### Enameled Clock Dials and Figures.

**Caesar Bros.**—Manufacturers of Enameled Clock Dials, also letters and numbers for signs. 230 and 232 East 25th Street, New York.

#### Enamelers, Etc.

**Nutt, J. D.**—Enameler on Gold, Silver, and Copper. Linen finished Buttons and Studs. Enameling in colors. 32 and 34 John Street, New York.

**Orr, J. C.**—Enameler on Fine Jewelry. Enameled in Colors. Linen Finished Buttons and Studs. Band Bracelets. No. 75 Nassau Street, N. Y.

#### Engravers—Stone Seal, Etc.

**Fackner, Edward**—Carver, Engraver and Chaser on Jewelry and Pencil Cases, lettering, &c., 19 John Street.

**Holland & Gosling**—Stone Seal Engravers. Precious Stones inlaid and encrusted with Diamonds. No. 176 Broadway, New York, (fifth floor per elevator). Cameos cut and repaired.

**Knapp, Chas.** Engraver, Die Sinker & Stamper for Jewelry purposes. Ring Shanks & superior Band rings, 41 Maiden Lane, N. Y.

**Park, Wm.**—The Stone Seal Engraver. Arms, Crests, Monograms, etc., engraved on precious stones, 26 John Street, New York.

**Weston, James F.**—Stone Seal Engraver and inlaid of Precious Stones. Coats of Arms, Masonic, Odd Fellows, and other devices engraved. 32 John Street.

#### Fancy Goods, Clocks, Bronzes, Etc.

**Hinrichs, C. F. A.**—Importer of Fancy Goods, Glassware, China, Clocks, Bronzes, etc. 31 Park Place.

**Le Boutillier & Co.**—Importers of Fancy Goods, Clocks, Bronzes, &c., 33 West 23d Street.

**Straus, L. & Sons**—Importers of Potteries, Faïences, Bisque Figures, and Rich Fancy Goods especially adapted for the Jewelry Trade. 40, 42 and 44 Warren Street, New York.

**Taylor & Bro.**—Importers of French Clocks, Bronzes, etc. 676 Broadway, N. Y.

**Young, J. M. & Co.**—Importers of Fine Parian, Lava, and Bisque Statuary, Bohemian, German and English Fancy Goods, 37 & 39 Murray St., New York.

#### Gold and Silver Cane Heads.

**Cuppia, L. A.**—Importer of Filigree Jewelry and Manufacturer of Silver and Gold Cane Heads and Novelties in Silver and Gold Jewelry. 19 Union Square, N. Y.

**Locklin, F. P. & Bro.**—Manufacturers of Gold and Silver Headed Canes. 142 Fulton Street, N. Y.

**Simons, Bro. & Co.**—Manufacturers of Gold Headed Canes. 611 and 613 Sansom street, Philadelphia.

**Smith, Rest Fenner & Co.**—No. 701 Broadway, Makers of Fine Gold and Silver Headed Canes.

#### Gold and Silver Plating, Etc.

**Bantle, A.**—Gold, Silver and Electro-Plating, 130 Fulton and 89 Nassau Streets, cor. Fulton Street, (Room 36,) N. Y. Watch Case Polishing.

**Jeandheur, F.**—Gold and Silver Electro Plater and Fire Gilder. Coloring Etruscan and Gold Jewelry a Specialty. 125 Fulton Street.

**Klees & Magrath**—Gold and Silver Electro-Platers. Coloring Etruscan and Gold Jewelry a Specialty. 96 Nassau Street, New York.

#### Gold Chains, Etc.

**Beck, J. & Son,** Manufacturers of Fine Gold Chains and Chain Bracelets, 10 Liberty Place, near Maiden Lane, N. Y.

**Carter, Sloan & Co.**—Manufacturers of Fine Gold Chain, 15 Maiden Lane, New York.

**Edge, W. C. & Co.**—Manufacturers of the Celebrated Woven Fabric Gold Chain, No. 15 John Street.

**Kaufmann Bros.**—Manufacturers of Gold Chains, and Chain Bracelets, 12 First Street; Factory, 331 and 333 Bowery, N. Y.

**Kohn, Alois & Co.**—Manufacturers of Gold Chains. 9 Maiden Lane, N. Y.

**Saxton, Smith & Co.**—Manufacturers of Fine Gold Chain, No. 14 John Street, N. Y.

**Schlag, Chas.**—(Late Nordt & Schlag), Manufacturer of Gold Chains, Chain Bracelets and Fine Jewelry. 177 Broadway, New York. All kinds of Jobbing promptly attended to.

**Smith, W. & Co.**—Manufacturers of Gold and Silver Chains, Jewelry, etc. No. 25 Maiden Lane, N. Y.

#### Gold Pens, Etc.

**Aikin, Lambert & Co.**—Manufacturers of Choice Gold Pens, Cases, Holders, Toothpicks, etc., 23 Maiden Lane, N. Y.

**Faber, Eberhard.**—Manufacturer of 16-karat Gold Pens and Pencil Cases. Nos. 718 and 720 Broadway, N. Y.

**Fairchild, Leroy C. & Co.**—No. 10 Maiden Lane, New York. Manufacturers of Gold Pens, Pencils, etc.

**Fairchild, Leroy W.**—Manufacturer of Gold Pens, Pencil Cases, Tooth Picks and Novelties in Charms. No. 18 John St., N. Y.

**Foley, John**—Manufacturer of Fine Gold Pens, Pencils and Charms. 2 Astor House, N. Y.

**Hicks, W. S.**—Established 1848. Manufacturer of Fine Gold Pens, Pencil Cases, Tooth Picks, and Charm Novelties of every description. No. 20 Maiden Lane.

**Johnson, E. S. & Co.**—Manufacturers of Gold Pens, Pen Holders and Pencils. Cor. Maiden Lane and Nassau Street, New York.

**Smith, H. M. & Co.**—Manufacturers of Gold Pens and Holders, Tooth Picks, Pencils, etc. Sole Manufacturers of Sprague's Patent Gold Fountain Pen. Importers of Nickel and Silver Watches. 173 Broadway, New York.

#### Gold Filled Rings.

**Flint, Blood & Young**—Makers of Gold Filled and Rolled Plate Rings in a Large Variety. Office, 196 Broadway, New York.

#### Gold Rings.

**Barnet Bros.**—Manufacturers of Stone and Seal Rings, 15 John Street, New York. Factory, Newark, N. J.

**Bowden, J. B. & Co.**—Manufacturing Jeweler.—Solid Gold Rings a specialty, 1 Maiden Lane.

**Cable, Geo. W.**—Manufacturing Jeweler. Plain and Band Rings a Specialty. No. 52 Maiden Lane, N. Y.

**Dattelbaum & Friedman**—Manufacturers of Fine Cameo and Seal Rings, all kinds of Fancy Rings and Diamond Mountings. 10 Maiden Lane.

**Ely, W. H.**—Manufacturer of Solid Gold Rings of every description. No. 58 Nassau Street.

**Engelfried, Braun & Weidmann**—Manufacturing Jewelers, 128 Fulton Street corner Nassau, New York. Commercial Building, room 31. Rings a specialty.

**Henrich, R.**—No. 35 Maiden Lane, Manufacturer of Gold Rings; also Patentee and Manufacturer of the Celebrated Self-Sizing Ring

**Hutchison & Huestis**—Makers of Solid Gold Rings. Quality guaranteed. For the Jobbing Trade only. 196 Broadway, N. Y.

**Kroll, H.**—Manufacturing Jeweler. 78 Nassau Street, New York. Specialty: Solid Gold Stone Rings. All kinds of Fine Jewelry made to order, also Repairing for the Trade.

**Müller, H.**—111 Nassau St., N. Y., Manufacturer of Fancy and Seal Rings of every description. Plain Gold and Chased Band Rings in 10, 14 & 18 Kt.

**Ostby & Barton**—Manufacturers of Plain and Engraved Solid Gold Band Rings. Office, 176 Broadway, N. Y. Factory, 80 Clifford Street, Providence, R. I.

**Peckham, Wm. H.**—Manufacturers of Solid Gold Seamless Rings, and Fancy Embossed Rings, Patent Spectacles, Jewelry, etc. No. 4 Liberty Place N. Y.

**Radler, K.**—Manufacturing Jeweler. Gold Rings and Locketts a specialty. No. 179 Broadway, New York.

**Sauter, L.**—No. 1 Maiden Lane, New York, Manufacturer of Stone Rings of every description, as Diamond, Cameo, Onyx Turquoise, etc., Scarf Pins, Ring Rings, Studs and Buttons.

**Shafer & Douglass.**—Manufacturers of all kinds of Seal, Stone, Turquoise, and fancy rings. No. 7 Maiden Lane, N. Y.

**Thurner & Church**—Manufacturers of Fine Gold Rings. No. 9 Maiden Lane, N. Y.

#### Hair Jewelry.

**Moutoux, Wm. E. & Co.**—Manufacturers of Fine Hair Mountings in Gold. Grand catalogues for the trade. 81 Nassau St., Rooms 1 and 2. Finest work and lowest prices

**Sauter, L.**—Manufacturer of Fine Gold and Hair Jewelry and Device Work. Pattern Book sent on application. No. 1 Maiden Lane, N. Y.

**Schwencke O.**—Manufacturer of Fine Hair Jewelry Orders from the country promptly attended to. No. 43 Maiden Lane.

#### Initial and Monogram Jewelry.

**Miller Bros.**—Manufacturers of Sleeve Buttons, Studs, Collar Buttons, Lace Pins, Seals, Medallions, etc., Mounted with Old English, Block, Engraved, Rustic and Opalized Initials. Monograms to Order. 7 Maiden Lane.

#### Jewelry Cases, Fancy Boxes, Etc.

**American Morocco Case Co.**—7 & 9 Bond St., N. Y., make a specialty of Rich Jewelry, Silverware Cases and Improved Trays for Watches, Rings, &c. Patent Watch Blocks to fit all sizes.

**Braun, Chr. E.**—Manufacturer of Fine Jewelry Boxes and Trays for Show Cases and Trunks. No. 62 Chatham Street, New York. Trays for Show Cases and Trunks a Specialty.

**Bricka & Warmers**—Manufacturers of Morocco Cases for Cutlery, Silverware, Jewelry, etc. Sample Cards and Rolls. Cases in Rosewood, Black Walnut, etc. 52 Nassau Street, New York.

**Dennison Mfg Co.**—Manufacturers of Morocco, Plush and Velvet Jewelry and Silverware cases. New York, Boston, Philadelphia, Chicago, Cincinnati and St. Louis.

**Haensler, Chas. C.**—Manufacturer of Fine Morocco Cases for Jewelry and Silverware. Toilet Boxes, etc. Trays for Show Cases and Windows. 14 John Street, New York.

**Hebbard & Brother**—Manufacturers of Jewelry and Silver Ware Cases, and Fancy Wood Chests for Tea Sets and Flat Ware. 860 Broadway, New York.

**Jackson, S. C.**—Manufacturer of Fine Cases for Jewelry, Watches, Silverware, etc. 180 Broadway, N. Y.

**Kohn, Solomon**—Manufacturer of Fine Morocco Cases for Jewelry, Watches, etc. 43 Maiden Lane, New York.

**Lauten, Edw. A. & Co.**—No. 4 Great Jones St., Manufacturers of Fine Velvet, Brocade, Plush and Morocco Boxes, Patent Ring, Ear Ring and Gent's Scarf Pin Trays, Patent Watch and Bracelet Blocks, Window Decorations, etc.

**Lehmann, Ludwig**—Manufacturer of Jewelers' Findings. 122 Fulton Street, near Nassau, New York.

**Loehr & Koerner**—Manufacturers of Morocco, Velvet, Satin, Jewelry, Watches and Silverware Cases, Jewel, Work Boxes, etc., Fancy Trays and Store Fittings to order. 96 Liberty St.

**New York Morocco Case Co.**—Cases for Jewelry, Watches, Silverware. Boxes and Trays for Jewelers' Travelers. Show Cases and Window Fittings. No. 69 Nassau Street, New York.

**Schwarz, N.**—Manufacturer of fine Cases for Jewelry and Silverware. 866 Broadway, New York.

**Welch & Miller**—169 Broadway. Manufacturers of fine Morocco, Velvet, Russia, Brocade and Plush Jewelry Cases. Trays of every description; Jeweler's Cotton and Twine.

**Wiggers & Froelick**—No. 60 Nassau street—Manufacturers of Cases for Jewelry, &c., of every description. Trays for Show-cases, Stands for Show-windows, etc.

#### Jewelers' Findings.

**Dennison Mfg Co.**—Paper Jewelry Boxes, cards, tags, pink and white cotton, etc. etc. New York, Boston, Chicago, Cincinnati, Philadelphia, St. Louis.

**Ettlinger, L., & Sons**—Makers of Cases and Paper Boxes of every description for Jewelers and Silversmiths. Fine Cases and Trays to order a specialty; also Cards, Tags, Cotton, Tissue Paper, &c. 80 Nassau St., N. Y.

**Lehmann, Ludwig**—Manufacturer of Jewelers' Findings. 122 Fulton St., near Nassau, N. Y.

**Valfer, S. & Co.**—Manufacturers and Dealers in Jewelers' Boxes, Tags, Cards, Paper and Findings. Trays a specialty. Fancy Ornaments for Show Windows. 66 Nassau street, New York.

#### Jewelry Manufacturers.

**Aikin, Lambert & Co.**—Manufacturers General stock of Reliable Jewelry, 23 Maiden Lane.

**Alling, Isaac A. & Co.**—Manufacturers of Fine Gold Jewelry. Specialties: Wire Bracelets, Bangles, American Lever Sleeve Buttons. Bryant Building, Nassau and Liberty Streets, N. Y. Factory, Newark, N. J.

**Baldwin, Sexton & Peterson**—Manufacturers of Rich Jewelry, 602 and 604 Broadway, N. Y.

**Ball, W. H. & Co.**—Manufacturers of Gold Jewelry. Bracelets and Bangles of all kinds a specialty. 9 John Street, N. Y.

**Bissinger, Philip & Co.**—Importers of Diamonds, Pearls and Precious Stones. Sole Agents for the Bohemian Garnet Jewelry, Blue Enameled Locketts and Coral Goods. 22 John St., N. Y.

**Bonner & Abramovitz**—Manufacturers of Diamond Jewelry. Specialty, Ring Mountings. 128 Fulton Street, Room 30, New York.

**Brown, Thos. G. & Sons**—Manf'ts of Rich Jewelry Necklaces, Locketts, Bracelets, Sleeve Buttons, etc., 860 Broadway, N. Y.

**Bryant & Bentley**—Manufacturing Jewelers. Rings a specialty. 12 Maiden Lane

**Carter, Sloan & Co.**—Manufacturing Jewelers, 15 Maiden Lane, New York.

**Champenois & Co.**—No. 5 Maiden Lane, manufacturers of Engraved and Enameled Gold goods, in Sets, Ear Knobs, Bracelets, Studs, Lace and Shawl Pins, Jet cluster and Onyx goods, also "Best Lever" Sleeve Buttons.

**Chatellier, Joseph F.**—Manufacturing Jeweler, No. 694 Broadway, N. Y.

**Churchill, Lewis & Co.**—Manufacturers of Fine Jewelry. 692 Broadway, cor. Fourth St., N. Y.

**Cook, George W.**—Manufacturer of Fine Jewelry and Locketts, 191 Broadway (over Mercantile Bank,) N. Y.

**Cottle S. Co.**—Manufacturers of Fine Jewelry. 860 Broadway, N. Y.

**Cox & Sedgwick**—Manufacturers of fine Onyx and Colored Jewelry. 26 John St., New York

**Day & Clark**—Manufacturers of Fine Jewelry, Lace Pins, Ear Rings, Studs, Locketts, &c., 10 Maiden Lane, New York.

**Geoffroy, Arthur R. & Co.**—Manufacturing Jewelers. Novelties in Diamond Goods. No. 23 Maiden Lane, N. Y.

**Greene Wm. C. & Co.**—Goldsmiths; Manufacturers of Rich Sets in Taper Wire Coral. Office, 192 Broadway.

**Griffith, H.**—Manufacturing Jeweler. Gold and Plated Jewelry. Scarf Pins a specialty. Nutry Alley, near Concord St., Brooklyn, N. Y.

**Groeschel & Rosman**—Manufacturers of Fine Jewelry. No. 27 John Street, N. Y.

**Hartmann, P.**—Manufacturer & Importer of Fine Gold, Diamond, and Filigree Silver Jewelry, No. 36 Maiden Lane. P. O. Box 2,454.

**Hedges, A. J. & Co.**—Manufacturing Jewelers, 6 Maiden Lane.

**Henderson & Winter**—Jewelers, No. 15 Maiden Lane, New York. Specialties—Stone, Cameo, Onyx, Amethyst, Topaz, Pearl and Turquoise Rings.

**Jandorf, P. & Bro.**—Manufacturing and Wholesale Jewelers—all grades. Prompt Attention to Orders. We issue no catalogue. 196 Broadway, N. Y.

**Kipper, Vogel & Co.**—Manufacturing Jewelers, 17 Maiden Lane, New York.

**Kremetz & Co.**—Manufacturing Jewelers, No. 182 Broadway, N. Y.

**Kuhn, Doerflinger & Co.**—Manufacturers of Enameled and Roman Band Bracelets, also Fine Locketts Pendants and Lace Pins. 18 John street.

**Miller Bros.**—Manufacturers of Fine Jewelry, Diamond Goods, Sets, Lace Pins, Ear Rings, Scarf Pins, Sleeve Buttons, Studs, etc. 7 Maiden Lane, N. Y.

**Moore & Horton.**—11 Maiden Lane, Manufacturing Jewelers, Rings, Studs, Collars and Sleeve Buttons, Pins, Ear-rings, &c.

**Mulford & Bonnet**—No. 21 Maiden Lane, New York.

**Owen, G. & S. & Co.**—Manufacturing Jewelers. Office, No. 3 Maiden Lane.

**Richardson, Enos & Co.**—Manufacturers of Fine Gold Jewelry, Gold Chains, Locketts, Crosses and Necklaces. Colored and Etruscan Work. No. 23 Maiden Lane, New York.

**Richardson, J. W. & Co.**—Manufacturers of Jewelry. Masonic and other Emblems. 196 Broadway, N. Y. Manufactory, Providence, R. I.

**Riley, J. A. & Co.**—Manufacturing Jewelers. Etruscan Gold and Roman Bracelets, Lace Pins, Ear Rings, Scarf Pins, Brooch Pins, etc. No. 860 Broadway, N. Y.

**Ripley, Howland & Co.**—Manufacturers of Fine Jewelry and Platinum Tipped Diamond Settings. No. 17 Maiden Lane, N. Y.

**Schwencke, Wm.**—Manufacturing and Jobbing Jeweler. Repairing a specialty. Orders promptly attended to. No. 43 Maiden Lane, N. Y.

**Sexton & Cole**—Manufacturing Jewelers, Colored Gold and Onyx Goods a specialty. No. 30 Maiden Lane.

**Sheafer, W. H. & Co.**—Manufacturing Jewelers, Specialty Bangles and Bracelets, 15 John St., N. Y.

**Stites' Sons, E.**—Manufacturers of Fine Jewelry. No. 14 John Street, N. Y.

**Straat, F. A.**—Manufacturer of Fine Jewelry. Roman Goods, Rings, Diamonds. No. 43 Maiden Lane.

**Street, Geo. O. & Sons.**—Established 1837. Makers of Fine Jewelry, strictly first-class goods of our own make. No. 15 John Street, New York.

**Thoma, Ernest**—Manufacturer of Fine Jewelry, Sleeve Buttons, Rings, Ear-rings, &c. No. 173 Broadway, N. Y. Factory, Hackensack, N. J.

**Ward, Thos. M.**—Manufacturer of Fine Jewelry. Diamond Mountings a specialty. No. 25 John Street, N. Y.

**Wienhold, J.**—Manufacturer of Fine Jewelry. Diamond Mountings a Specialty. 24 John St.

**Woglom & Miller**—Manufacturers of Black Onyx Goods exclusively. 32 & 34 John Street, N. Y.

#### Jewelry—Rolled Plate.

**Blackinton, W. & S.**—Manufacturers of the W. & S. B. Rolled Plated Chains. No. 11 Maiden Lane.

**Mauran, J. T.**—Manufacturer of Fine Rolled Plate Jewelry, No. 15 Maiden Lane, N. Y.

**Richards, E. Ira & Co.**—Manufacturers of Fine Rolled Plate Jewelry, No. 200 Broadway, N. Y.

#### Jewelers' Tools, etc.

**Fisher, James J.**—Dealer in Watchmakers' and Jewelers' Materials, Files, Tools, Silk Guards, Spectacles, etc. 695 and 697 Broadway, N. Y.

**Friedenthal & Rypinski**—Importers and jobbers of Watchmakers' and Jewelers' Tools, Materials, etc. 43 Maiden Lane, N. Y.

- Friedlander, R. & L.**—Importers of Watchmakers' Tools and Materials. 65 & 67 Nassau Street. Branch Office, 264 Bowery.
- Koester, C. F.**—Importer and Manufacturer of Fine Tools, Files and Polishing Materials for Jewelers, Watch Case Makers, etc. 33 John St.
- Kurtz, F. P.**—Manufacturer of Jewelers Machinery, Tools, Rolling Mills, Presses, Polishing Lathes, &c. 97 Cliff St., N. Y.
- Levy, Dreyfus & Co.**—Importers and Jobbers of Watchmakers' and Jewelers tools and materials of every description. 11 Maiden Lane, N. Y.
- Reichhelm, E. P. & Co.**—Importers of Jewelers' Tools, Files, etc. Manufacturers of Brushes and Buffing wheels; also Patent Gas Furnaces for Melting, Plating, Enamelling, Annealing, etc. 80 Nassau St., N. Y.

#### Lapidaries.

- Fox, M. & Co.**—Practical Lapidaries, No. 1 Maiden Lane, New York.
- Graham & Co.**—Practical Lapidaries, Cutters and Polishers of all kinds of Precious Stones, Emeralds, Rubies, Sapphires, etc. Miner's Relics Cut, Polished and Mounted. Locket Glasses. 80 Nassau St., N. Y.
- Kordmann & Michel.**—Lapidaries. Dealers in Precious Stones. Cutting and Polishing Rubies, Sapphires and other Gems a specialty. Drilling done promptly. 59 Nassau St., N. Y.

#### Masonic Jewelry.

- Luther, John F.**—79 Nassau Street. Manufacturer of Fine Presentation Jewels for all Societies. Knights Templars, Crosses, Badges, &c.
- Wilkinson, C. B.**—Manufacturing Jeweler, 8 John St., N. Y. Medals, Badges and Masonic Jewelry, a specialty. Designs furnished free upon application.

#### Musical Boxes.

- Paillard, M. J. & Co.**—Manufacturers of Musical Boxes and Musical Novelties. Warerooms, 680 Broadway, N. Y.

#### Optical Goods.

- Friedlander, R. & L.**—65 and 67 Nassau Street. Dealers in Optical Goods.
- Spencer Optical Manufacturing Co.**—Manufacturers of Spectacles and Eye-Glasses. 13 Maiden Lane, N. Y.

#### Opticians.

- Burbank Man'g Co.**—Manufacturers of Spectacles and Eye Glasses of all descriptions, in gold, silver, etc., 14 Maiden Lane, N. Y.
- DuBois, Geo. W. & Co.**—Importers of Watches and Optical Goods. 36 Maiden Lane, N. Y.
- Levy, Dreyfus & Co.**—Importers of Spectacles and Eye Glasses and Optical Instruments of every description, No. 11 Maiden Lane, N. Y.
- Lorsch, Albert**—Manufacturer of the Patent Accommodating Spectacles and Eye Glasses in Gold, Silver and Steel, and other Optical Goods, 37 Maiden Lane, N. Y.
- New York Optical Co.**—Makers of Gold, Silver, German Silver and Steel Spectacles, Eye-Glasses, etc. Jay and Plymouth Streets, Brooklyn, N. Y.
- Spencer Optical Manufacturing Co.**—Gold, Silver, Steel, Nickel and Plated Spectacles; Gold, Celluloid, Steel, Nickel and Rubber Eye Glass and Opera Glasses. 13 Maiden Lane, N. Y.
- Todd, James W.**—No. 20 Maiden Lane, N. Y. Wholesale Dealer in Optical Goods.

#### Paper Boxes.

- Lehmann, Ludwig.**—Manufacturer of Jewelers' Findings. 122 Fulton St., near Nassau, N. Y.
- Waterbury Paper and Box Co.**, 27 to 35 Canal St., Waterbury, Conn., Manufacture Jewelers' and Silversmiths' Fine Paper Boxes. Quality guaranteed to be equal to the best made.

#### Polishers and Lappers.

- Klees & Co.**—Late Abels, Polishers and Lappers of Fine Jewelry. 89 Nassau St., Room 17, N. Y.

#### Precious Stones, &c.

- Bishop, Victor & Co.**—33 Maiden Lane, Importers of Precious Stones, Cameos, &c. Also Manufacturers of Coral Jewelry.
- Bissinger, Philip & Co.**—Importer of Diamonds, Pearls and Precious Stones. Agent for the Bohemian Garnet Goods. Blue Enamelled Lockettes and Coral Goods. No. 22 John St., N. Y.

**Breidenbach, R. A.**—Importer of Black Onyx, Diamonds, Pearls, Turquoise, Cameos, Sardonyx, Amethysts, Garnets, Topaz, Opals, Rubies, Sapphires, Hematite Balls, Foil Brilliants, Cat's-Eyes, Tiger Eyes, Doublets, Cabinet Specimens, etc. 85 Nassau Street, New York.

**Daue, Wm. & Co.**—Importer of Precious and Imitation Stones. No. 202 Broadway New York.

**Fox, M. & Co.**—Importers of Diamonds and other Precious Stones, No. 1 Maiden Lane, N. Y.

**Gruet, Jules.**—Importer of all Grades of Real and Imitation Stones. 14 John St., N. Y.

**Hahn, Rudolph C.**—Importer of Precious Stones. Agates, Tiger Eyes, Cameos, Intaglios, etc. 25 Maiden Lane, N. Y. Branch, 151 Broad Street, Providence, R. I.

**Hahn & Co.**—Importers of Precious Stones. Cameos, Onyx, Pearls, Intaglios, Amethysts, Garnets, etc. 64 Nassau Street, New York.

**Kahn, L. & M. & Co.**—Importers of precious and imitation stones. 10 Maiden Lane, N. Y.

**Kipling, E. E.**—Importer of Precious and Imitation Stones. Manufacturer of the Patent Foil Solid Metal Back Rhine Stone Brilliant. No. 6 Maiden Lane, N. Y.

**Kipling, R. A.**—Precious and Imitation Stones, No. 24 Maiden Lane, N. Y. Manufacturer Cameos, Agates, Onyx, Etc., Oberstein, Germany. Commission Merchant, 49 Rue De L'Echiquier, Paris.

**Lorsch, Albert**—Importer of Precious Stones, 37 Maiden Lane, N. Y.

**Stirn, Oppenheimer & Co.**—Importers of Black Onyx, Cameos, Turquoise, Sardonyx, Garnets, Rubies and all other Precious and Imitation Stones. German, French and Vienna Novelties. 3 Maiden Lane, N. Y.

#### Safes.

**Butler, W. H.**—Fire and Burglar Proof Safes, 291 Broadway, N. Y.

#### Silverware.

**Dominick & Haff**—Makers of Wares in Sterling Silver for the Trade only. Broadway and 17th Street, Union Square, New York.

**Gorham Manufacturing Co.**—Broadway and 19th Street.

**Knowles, J. P. & S. M.**—Manufacturers of Sterling Silverware, 20 Maiden Lane, N. Y. Factory, Providence, R. I.

**Shiebler, Geo. W.**—Manufacturer of Sterling Silverware. No. 8 Liberty Place, near Maiden Lane, N. Y.

**Whiting Manufacturing Co.**—Makers of Sterling Silver Ware. Broadway cor. 4th Street, N. Y.

**Wood & Hughes.**—Manufacturers of Fine Silverware. 16 John Street, N. Y.

#### Silver Filigree Jewelry.

**Cuppia, L. A.**—Manufacturer of Solid Silver Novelties, and Importer of Silver Filigree, 19 Union Square.

**Francesconi, Guido**—Importer of Silver Filigree Jewelry, 196 Broadway, New York.

**Hartmann, P.**—Manufacturer of Silver Filigree Jewelry. 36 Maiden Lane, N. Y.

#### Silver Plated Ware.

**Manhattan Silver Plate Co.**—Manufacturers of Silver Plated Ware. Showrooms, 23 John St. Factory, 301 to 305 East 22d St., cor. 2d Ave. Address all communications to Factory.

**Middletown Plate Co.**—Manufacturers of Superior Electro-Plate. Factories, Middletown, Conn., salesroom, 13 John Street.

**Rogers, Smith & Co.**—Manufacturers of Fine Electro Plated Ware. No. 46 E. 14th St., N. Y.

**Rogers & Brother**—Manufacturers of Electro-Plated Flat and Hollow Ware. 690 Broadway, N. Y.

**Schade, Henry.**—Manufacturer of White Metal and Plated Ware. Office, 26 John Street, N. Y. Price list and catalogue furnished on application.

**The Derby Silver Co.**—Manufacturers of Finest Quadruple Silver Plated Ware, Birmingham, Conn. New York office, 25 Maiden Lane.

**Webster, E. G. & Bro.**—Manufacturers of Fine Silver-Plated Ware. Office and warerooms, 14 Maiden Lane, N. Y.

#### Show Cases, Etc.

**Smith, B. & W. B.**—Manufacturers of Patent Improved Dust Proof Show Cases, with Perpendicular Sliding Doors, No. 220 W. 29th St., N. Y.

#### Spectacle Case Manufacturers.

**Bertine, P. D.**—Manufacturer of Spectacle and Eye-Glass Cases. 139 William Street, near Fulton St., New York.

**Koenen, A. & Bro.**—Manufacturers of Leather Spectacle and Eye-Glass Cases for the Jobbing Trade only. 81 Nassau St., N. Y.

**New York Optical Co.**—Makers of Spectacle and Eye-Glass Cases. Jay and Plymouth Streets, Brooklyn, N. Y.

**Spencer Optical Manufacturing Co.**—Manufacturers of Spectacle and Eye-Glass Cases. 13 Maiden Lane, N. Y.

#### Steel Stamps.

**Waddell, H.**—Maker of Steel Stamps, Figures and Alphabets. 7 North William Street, N. Y.

#### Stem Winding Attachments.

**Abbott, Henry** Maker of Stem Winding Attachments, No. 4 Maiden Lane, N. Y.

#### Swivels and Spring Rings.

**Schwartz, V. & Co.**—Manufacturers of Gold Swivel and Chain Trimmings. 33 Barclay Street, New York.

#### Thermometers, Etc.

**Tagliabue, Giuseppe.**—manufacturer of Thermometers, Barometers and Hydrometers. Patentee and sole manufacturer of the U. S. Standard Hydrometer. 302 Pearl Street, near Beekman.

#### Thimble Manufacturers.

**Ketcham & McDougall.**—Improved Gold and Silver Thimbles, Bryant Building, N. Y.

**Simons Bro. & Co.**—Manufacturers of Gold and Silver Thimbles. 611 and 613 Sansom Street, Philadelphia.

**Woglom & Miller.**—Sole Agents for the "Prime" Thimbles in Gold and Silver, manufactured by Ezra C. Prime. 34 John Street, N. Y.

#### Trunks.

**Crouch & Fitzgerald**—Manufacturers of Trunks and Articles for Travelers' use. 1 Cortlandt St., 556 Broadway, and 723 Sixth Ave., N. Y.

#### Watch Companies.

**American Watch Co.**—Robbins & Appleton, No. 5 Bond Street, N. Y.

**The E. Howard Watch and Clock Co.**—Cor. Maiden Lane and Nassau Street, N. Y.

**Waterbury Watch Co.**—Manufacturers of the Waterbury Watch. Factory, Waterbury. Office, 52 Maiden Lane, N. Y.

#### Watch and Chronometer Jewelers.

**Queen, James.**—Watch and Chronometer Jeweler and Pallet Maker, 78 Nassau Street, room 8. Pivots inserted in Pinions, Balance, Staffs, etc.

**Robert, Henry L.**—Practical Chronometer and Watch Jeweler and Adjuster. 71 Nassau Street. Pallet and Hole Jewels for Chronometer Watches done in the best manner.

**Wennstrom, John.**—Watch, Chronometer and Clock Jeweler, Jewel Gauges, Ruby and Sapphire Draw Plates; Diamond Charged Polishing Stones for Jewel Settings; Pivots inserted in Pinions. 2 Dutch Street, N. Y.

#### Watch Importers, Etc.

**Abry, Chas. Leo**—Importer and Manufacturer of Swiss Watches of all grades. 63 Nassau Street.

**Aikin, Lambert & Co.**—Importers of Watches. Sole Agents for Paul Breton & Chas. Latour, Geneva. A general line of reliable Swiss Watches, Watch Cases, etc. 23 Maiden Lane, N. Y.

**Bartens & Rice**—20 John Street, Importers of Watches and sole agents in the United States for the celebrated Nicole, Nielsen & Co. Watches.

**Cross & Beguelin.**—Importers of Watches, Watch Tools and Materials, dealers in American Watches, No. 21 Maiden Lane, N. Y.

**Droz, Henry E.**—Importer of Watches, and Watch Case Manufacturer. Agent for the "E. Perregaux" Watch, and jobber in American Watches No. 92 Fulton Street, N. Y.

**Freund Max & Co.**—Importers of Watches, Jewelry and Precious Stones, 8 Maiden Lane, N. Y.



- Gagnebin, Chas.**—Importer of all kinds of Swiss, and Dealer in American Watches. 4 Maiden Lane, N. Y. Agent for Ulysse Breting's Fine Chronometers, Chronographs, Anchors, &c.
- Gallet, Julien.**—Importer of Watches. No. 1 Maiden Lane.
- Ginnel, Henry.**—Importer of Watches, Tools and Materials, 31 Maiden Lane, N. Y. P. O. Box 2967
- Hyde's Sons, John E.**—Wholesale Commission Agents, only for Jules Jurgensen, of Copenhagen; Jules Monard, of Geneva; and for other makers of all qualities of Watches, 22 Maiden Lane.
- Keller, L. H. & Co.**—Successors to G. A. Huguenin, Importers of Fine Watch and French Clock Materials, No. 64 Nassau Street, N. Y.
- Mathey Bros. & Mathez.**—Importers of Fine Watches and Sole Agents for the **H. L. Matile's** Watches. No. 16 Maiden Lane.
- Robert, J. Eugene.**—No. 30 Maiden Lane, New York. Agent for Louis Audemar's celebrated watches.
- Schumann, Chas. W.**—No. 24 John Street, New York. Importer of Fine Diamonds, Watches, etc. Sole Agent in the U. S. for the celebrated "Lange" Dresden Watch.
- Schwob, Adolphe.**—Manufacturer and Importer of Watches, 5 Maiden Lane, N. Y.
- Strasburger, Louis & Co.**—Importers and Makers of Watches of every description, 15 Maiden Lane.

#### Watch Cases.

- Dueber Watch Case Mfg Co.**—Manufacturers of Gold and Silver Watch Cases. Bryant Building, N. Y. Factory, Newport, Ky.
- Fahys, Joseph.**—Manufacturer of Watch Cases and Dealer in American Movements, 38 Maiden Lane.
- Keller & Untermeyer.**—Manufacturers of Watch Cases with Raised Gold Ornaments. 9 Maiden Lane, N. Y.
- Ladd Watch Case Co.**—Manufacturers of the Ladd Patent Stiffened Gold Watch Cases, etc., 11 Maiden Lane, N. Y. Factory, 58 Eddy Street, Providence, R. I.
- Tissot, H.**—Manufacturer of Gold Watch Cases. No. 15 Maiden Lane, N. Y.
- Willemin Watch Case Co.**—Makers of Gold Watch Cases. Raised Gold Ornamentation and Jurgensen style of Engine Turning. 109 Sands Street, Brooklyn, N. Y. 16 Maiden Lane, N. Y.

#### Watch and Chronometer Repairers.

- Cerf, B.**—Practical Watchmaker and Repairer, No. 10 John Street, N. Y. Repairing and adjusting of Fine Watches done for the trade. All kinds of escape and stem-winding wheels cut to order.
- Heinrich, H. H. & Co.**—Sole Manufacturers of H. H. Heinrich's Patent Auxiliary Balance, and Adjusters and Repairers of Fine Watches and Chronometers. 18 John Street, N. Y.
- La Croix, J. H.**—(Late with Benedict's Time,) Watch and Clock Maker, 21 John Street, N. Y. Clocks of every description Repaired for the Trade.
- Lesperance, Theo.**—Watchmaker and Wheel Cutter. No. 1 Maiden Lane, New York. With Julien Gallet.

#### Watch Case Repairers.

- Feinier, Joseph A.**—Watch Case Maker and General Repairer. Specialty in fine Gold and Silver Cases. Jobbing promptly attended to. Nos. 4 and 6 John St., N. Y.
- Tarbox, Hiram.**—Watch Case Repairing, Springing, Polishing and Engine Turning. 1874 North Fourth Avenue, bet. 176th and 177th Sts., N. Y. Express Packages should be sent to 92 Fulton Street.

#### Watch Glasses, Shades, Etc.

- Brown, Edwin H.**—No. 85 Nassau Street, Imported and Own Manufacture Watch Glasses, Flat, Flat Concave, Concave, Convex and fine Genevas. Fine fitting solicited.

#### Watches, Diamonds and Jewelry.

- Alford, C. G. & Co.**—Manufacturers. General line fine and Reliable Goods. Specialties in Onyx Goods and Chain. 200 Broadway, New York.

- Bynner, T. B.**—Watches, Diamonds and Jewelry. Also a full line of best quality Roll Plated Jewelry. 908 Broadway, between 20th and 21st Streets, Continental Hotel, New York.
- Cohn, J. J.**—Importer and Manufacturer of Whitby Jet, Rubber and Pearl goods. Gold and Rolled-plate Jewelry, etc. 12 Maiden Lane, New York.
- Durfey & Reynolds.**—Successors to Durfey & Shiebler, Watches, Diamonds, Jewelry. No. 9 John Street, (up-stairs) New York.
- Goddard, John M.**—Manufacturing Jeweler, Seal Rings and Fine Locketts a specialty, No. 3 Maiden Lane, N. Y.
- Greason J. R. & Co.**—Successors to Arthur, Rumrill & Co., 182 Broadway. Manufacturers of Fine Jewelry and Gold Chains, also Diamond Mountings.
- Haskell, H. C.**—Manufacturing Jeweler. Seal Rings a specialty. Special attention to Jobbing of every description. 12 John street.
- Herzog, Louis & Co.**—Importers of Watches, Dealers in Diamonds and Jewelry, 52 Maiden Lane, N. Y.
- Hirsch Bros.**—Dealers in Watches and Diamonds and Manufacturers of Jewelry, No. 23 Maiden Lane, N. Y.
- Jandorf, P. & Bro.**—Importers of Watches and Jewelry, 196 Broadway.
- Lissauer & Sondheim.**—Wholesale Jewelers and Jobbers in American Watches, No. 12 Maiden Lane, N. Y.
- Marx, Kossuth & Co.**—Importers of Watches and Dealers in Jewelry. 39 Maiden Lane, N. Y.
- May, Henry.**—Importer and Wholesale Dealer in Watches and Diamonds, and Manufacturing Jeweler. 19 John St., N. Y.
- Mayer, B.**—Manufacturer of Fine Jewelry, and Dealer in Watches, 71 Nassau street, cor. John street, New York.
- Myers, S. F. & Co.**—Manufacturing and Wholesale Jewelers—all grades. Importers of Watches. Illustrated Catalogue to the trade. 179 Broadway, N. Y.
- Oppenheimer Bros. & Veith.**—Dealers in Watches and Diamonds, and Manufacturing Jewelers, No. 35 Maiden Lane.
- Scott, J. T. & Co.**—Importers of Watches, and Manufacturers of Jewelry, and Jobbers of all Grades of American Watches, 4 Maiden Lane.
- Smith & Knapp.**—Wholesale Dealers in American and Swiss Watches, Diamonds, Gold and Plated Jewelry and Gold Chain. 182 Broadway, N. Y.
- Steele, J. W.**—Successor to Brainerd, Steele & Co., Manufacturer of Fine Jewelry and Brainerd's Patent Locketts. No. 9 Maiden Lane, N. Y.
- Stern & Stern.**—Dealers in Watches, Jewelry and Diamonds. No. 6 Maiden Lane, N. Y.
- Stites, D. H. & Son.**—Manufacturers of Fine Jewelry, Rolled Plated Goods and Chains, Parisian Diamond Rings, Studs and Earrings a specialty. 41 Maiden Lane, N. Y.
- Strauss, Jacob.**—Full Line of Gold and Plated Jewelry, and Importer of Watches. 18 John Street, New York.
- Thrall, E. A.**—Wholesale Dealer in Watches and Jewelry. No. 1 Maiden Lane, N. Y.
- Trier Bros.**—Importers of Garnet, Whitby Jet and Amber Jewelry, Silk Guards, Opera, Field and Marine Glasses, Pearl Card Cases. Also a full line of Gold and Plated Jewelry. 15 Maiden Lane, N. Y.
- Wheeler, Parsons & Hays.**—Manufacturers of Fine Jewelry, Watch Cases, Gold Chains, &c. and Dealer in American and Swiss Watches, No. 2 Maiden Lane, N. Y.
- White, N. H.**—Jobber in American-Waltham Watches and Chronographs. Waltham make of 10-k., 14-k. and 18-k. Gold and Sterling Silver Cases; Filled Gold Cases. 11 Maiden Lane.

#### Watch Tools, etc.

- Keller, L. H. & Co.**—Importers of Watchmakers' and Jewelers' Tools, Materials, etc. 64 Nassau Street, N. Y.
- Zimmern, Henry.**—Importer of Watch Materials, Tools, and Optical Goods, No. 8 Maiden Lane, (first floor.) Sole Agent for A. Huguenin & Gravier. Mainsprings, New York.

### PHILADELPHIA

- Beitel & Kinsler.**—Engine Turners and Engravers of Watches and Jewelry. Also Dealers in American Watches, Solid Gold and Rolled Plate Chains. Ledger Building, 4th floor, Entrance 104 South 6th Street.
- Bennett, Jacob & Son.**—Diamond Setters and Manufacturing Jewelers, 925 Chestnut St.
- Booz & Co.**—Makers of Fine Gold Watch Cases and Plain Gold Rings, also Dealers in all American Movements, Diamonds, Jewelry, etc. 108 South 8th Street, Philadelphia.
- Conover David F. & Co.**—American Watches, Wholesale Salesroom, Southeast corner 7th and Chestnut Streets, Philadelphia.
- Krieder, Peter L.**—Manufacturer of Sterling Silver Ware. 618 Chestnut Street, Philadelphia.
- McCall & Newman.**—Manufacturing Jewelers. Makers of the Original Gold Crown Filled Rings. No. 625 Arch St., Philadelphia.
- Morgan & Headly.**—Manufacturing Jewelers. Cameo Sets, Gold Sets, Roman Locketts, Rings, Coral Sets and a general line of rich goods. Corner 10th and Chestnut Streets, Philadelphia.
- Peters, Reese S.**—Manufacturer of Patent Rolled Plate or Filled Watch Cases, Dealer in American Movements, 308 Chestnut Street, Philadelphia.
- Rosenthal, G. F. C.**—Manufacturing Jeweler and Diamond Setter. Engraving and Designing of Monograms a specialty. No. 917 Sansom Street.
- Scherr, L. A. & Co.**—Wholesale Dealers in Watches Silver-Plated Ware, Spectacles, Fancy Goods, Watch Materials, etc. 726 Chestnut Street.
- Sheafer, W. H. & Co.**—Manufacturing Jewelers. Specialty: Band Bracelets. Factory, 612 and 614 Chestnut street, Philadelphia. Office, 15 John street, New York.
- Simons, Brother & Co.**—Manufacturers of Fine Jewelry, Canes, Thimbles, Chains. 611 and 613 Sansom Street.

### CHICAGO.

- American Watch Company.**—of Waltham, Mass. No. 102 State Street, Chicago.
- Clapp & Davies.**—Wholesale Jewelers, 63 and 65 Washington Street. Catalogue and price list issued to watchmakers and jewelers.
- Dennison Manufacturing Co.**—Manufacturers of Jewelers' Paper Boxes, Morocco Cases, Tags, Cards, Pink and White Cotton, Tissue Papers, Sealing Wax, &c., &c., 102 Madison St., Chicago. Boston, New York, St. Louis, and Philadelphia.
- Gilbert, Wm. L., Clock Co.**—Manufacturers of Clocks, Regulators, and Time Pieces, and Clock Material of every description, 54 and 56 Madison Street, Chicago.
- Giles, Bro. & Co.**—Manufacturers and Jobbers in Watches, all classes of Jewelry, Materials, Clocks, Silver Ware, &c. Illustrated catalogues furnished to dealers on application. 101 & 103 State St.

### NEWARK.

- Baker & Co.**—Gold, Silver and Platinum Refiners Assayers and Sweep Smelters. 408 New Jersey Railroad Avenue, cor. Murray St., Newark, N. J.
- Diefenthaler Bros. & O'Donnell.**—Manufacturers of Fine Jewelry, Lace Pins, Ear Rings and Patent Spring Bangles a Specialty. 36 Crawford Street, Newark, N. J.
- English & Miller.**—Manufacturers of Gold Jewelry, Diamond and Fancy Stone Rings, Roman Locketts, Bangle and Flexible Bracelets, Knife Edge Lace Pins and Sets, Scarf Pins and Link Buttons. 61 and 63 Hamilton St., Newark.
- Felger, F. & F.**—Manufacturing Jewelers. Specialties:—Roman Band Bracelets, Lace Pins, Scarf Pins, Ball and Fancy Ear Rings. No. 477 Washington Street, Newark, N. J.
- Fiedler, Herrman.**—Successor to Kunze & Fiedler, Engraver, Die Sinker and Press Tool Maker, 363 Market Street, Opposite Pennsylvania R. R. Depot, Newark, N. J.
- Glorieux, W. L.**—Assayer, Refiner and Sweep Smelter. 13 and 15 Franklin Street, Newark, N. J.

**Hopper & Wilson**—Manufacturers of Fine Jewelry, No. 8 Maple Place, Rear 44 Green St., Newark, N. J.

**Höger & Heitlinger**—Manufacturers to the Jobbing Trade only. Makers of Roman, Stone, Engraved and Enameled Locketts a specialty. Also Sleeve Buttons, Collar Buttons and Studs. 477 Washington Street, Newark, N. J.

**Krippendorf, C. & Schuller, F.**—Machinists and Jewelers' Tool Makers. 19 Greene Street, Newark, N. J. Rolls, Dies, Cutters, and Draw-plates of every Description made and repaired.

**Lelong, L. & Bro.**—Gold and Silver Refiners Assayers and Sweep Smelters, Southwest corner of Halsey and Marshall Streets, Newark, N. J.

**Milne, Alex.**—Manufacturer of Stem-winding Watch Crowns. 19 Ward Street.

**Nesler & Co.**—Manufacturers of 18 Kt. Gold Filled Hoop Ear Rings, Plain, Facet and Engraved, all sizes. 36 Crawford St., Newark, N. J.

**Regad, E. D.**—Lapidary. Specialty—Sardonyx, Black Onyx and Agates. 14 Oliver St., Newark.

**PROVIDENCE**

**Arnold & Webster**—Manufacturers of Solid Gold Engraved Band Rings for the Jobbing Trade. 29 Point Street, Providence, R. I.

**Butts, Geo. F.**—Manufacturing Jeweler. Ladies' and Misses' Solid Gold Drops and Studs a Specialty. 119 Orange Street, Providence, R. I.

**Bradley, R. & Son**—Manufacturers of Solid Gold and Rolled Plate Jewelry. White Stone Goods a Specialty. 227 Eddy Street, Providence, R. I.

**Elmwood Paper Box Co.**—Makers of Jewelers' Cases, Trays, etc. Factory, 54 Greenwich St., Providence, R. I.

**Fry & Read**—Manufacturers of Sterling Silver and Gold Plated Jewelry. Antique Work a Specialty. 28 Potter Street, Providence, R. I.

**Hamilton, William & Co.**—Manufacturers of Fine Rolled Plated Chains and Patent Band Bracelets. 116 Pine St., Providence, R. I.

**Harrington, J. C.**—Maker of Fine Gold Plated Jewelry. Specialties:—Oval Wire Bangles, Band Bracelets and the Victor Swivel. 129 Eddy St., Providence, R. I.

**Hough, W. S., Jr., & Co.**—Manufacturers of the Hough, Jr., Rolled Plate Locketts, Charms and Pendants. For sale by all first-class Jobbers or Wholesale Jewelers in the United States and Canadas.

**Hutchison & Huestis**—Makers of Solid Gold Rings. Quality guaranteed. For the Jobbing Trade only. 185 Eddy Street, Providence, R. I.

**Irons, Chas. F.**—Manufacturer of Solid Gold Jewelry. Specialty, Emblems, Pins and Charms, Masonic, Odd Fellows, etc. 102 Friendship St.

**Pitts & Hicks**—Manufacturers of the Excelsior Button and Eclipse Lever Button, also a line of White Stone Gold Goods and a fine line of Lace Pins and Drops in Rolled Plate Goods. 120 Dorrance Street, Providence, R. I.

**Taylor, Geo. H. & Co.**—Watchmakers and Wholesale Dealers in Watches, Clocks, Watch and Clock Material, Tools, Spectacles, Eye Glasses, &c. Particular attention given to trade work. 136 Westminster Street (Room 1), Providence, R. I.

**Waite, Smith & Co.**—Manufacturers of Gold and Plated Jewelry. Gold Chain Trimmings a Specialty. Plated Stone Rings, White Stone Goods. 61 Peck Street, Providence, R. I.

**PAWTUCKET.**

**Fuller, Geo. H. & Son**—Jewelers' Findings, Gold, Silver, Gold Plated and Fire Gilt. Pin Stems, Joints, Catches, Split Rings, Chain Hooks and Swivels, Ear Wires, Chain Bars, etc. 99 Exchange Street, Pawtucket, R. I.

**CINCINNATI.**

**Holland, John**—Manufacturer of Gold Pens, Pencils and Pencil Cases, Gold Toothpicks, etc. Nos. 19 and 21 W. 4th St., Cincinnati, Ohio.

**Lodwick & Nolting**—Wholesale Jewelers (exclusively), S. W. cor. Fourth and Walnut Streets, Cincinnati, Ohio.

**BOSTON.**

**Boston Watch Case Co.**, makers of Watch Cases. Especial attention given to Repairing. 1, 3 & 5 Province Court, Boston, Mass.

**Boyce, E. J.**—Manufacturer of Solid Gold Jewelry. Rings a Specialty. 383 Washington St., Boston, Mass.

**Thiery Watch Case Co.**—Sole Manufacturers in the United States of Solid Nickel and Nickel Silver Cases. 309 Washington Street, Boston, Mass.

**Weber, H. & Co.**—Wholesale Jewelers, Importers and Jobbers of Fine Watch Materials, Jewelers' Findings, Tools, etc., Optical Goods and Silk Guards. Agents for Whitcomb, Standard and Stark's Lathes. 424 Washington St., Boston, Mass.

**BUFFALO.**

**Klein, E. F. O.**—Jobber in Watch Materials. Watches and Chronometers repaired and adjusted for the trade; also Gold and Silver Plating. Sample Bottle of "Magic Solution," for cleaning Watches, including receipt, to any address, on receipt of \$1.50. This is a great time-saver and does the finest work. No one will do without it if used once. 346 Broadway, Buffalo, N. Y.

**Oliver, W. W.**—Manufacturer of Hand and Power Rolling Mills for Jewelers and Silver-smiths, 39 Clinton Street, Buffalo, N. Y.

**LANCASTER.**

**Bowman & Musser**—Jobbers in Watches, Clocks, Chains, Fine Tools and Materials. 20 East Chestnut Street, Lancaster, Pa.

**PITTSBURGH.**

**Barrett, G. B., & Co.**—Wholesale Jewelers and Diamond Importers. We carry a line of everything required by the trade. Lowest prices guaranteed. 101 Fifth Avenue, Pittsburgh, Pa.

**Goddard, Hill & Co.**—Wholesale Dealers in American Watches, Jewelry, Silverware, Clocks, Materials, &c., 43 Fifth Avenue, Pittsburgh, Pa.

**Hodge, Slemmons & Co.**—Wholesale Dealers in American and Swiss Watches, Diamonds, Gold and Plated Jewelry, Clock Material, etc. No. 77 Fifth Ave., Pittsburg.

**NEW BEDFORD.**

**Wheeler, G. B.**—Manufacturer of Watch and Chronometer Oils, New Bedford, Mass.

**WORCESTER.**

**Washburn & Moen Manufacturing Co.**—Makers of Fine Watch Mainsprings, Worcester, Mass. 16 Cliff Street, New York. 107 to 109 Lake Street, Chicago, Ill.

**WINCHESTER.**

**Goodell & Winn**—Manufacturers of American Watch Hands, Winchester, Mass.

**ALBANY.**

**Reiss, Chas.**—31 and 33 So. Pearl Street, Albany, N. Y. Importer of Watch Tools and Material; General Supply; Low Prices. Repairing for the Trade.

**KEOKUK, IOWA.**

**Ayres, T. R. J., & Sons**—Wholesale Jewelers. Watches, Jewelry, Diamonds, Silverware, Clocks, Optical Goods, Tools, Material, &c, at lowest eastern prices. Correspondence solicited.

**CANADA.**

**Ellis, P. W. & Co.**, No. 31 King street, East Toronto, Ontario, Manufacturing Jewelers, Watchmakers, Importers and Jobbers of Watchmakers, and Jewelers' Tools, Materials, General Supplies and American Jewelry. Correspondence solicited with manufacturers of Novelties or specialties in American Tools and Jewelry.

GEO. W. DUBOIS.

F. N. NAUMAN.

**GEO. W. DUBOIS & CO.,**

IMPORTERS OF

**Watches & Optical Goods.**

ALL STYLES AND QUALITIES OF

**SPECTACLES AND EYE-GLASSES.**

**Longines' Watches and Movements,**

The Watches in Gold, Silver and Nickel Cases of New and Handsome Patterns. The Movements fit 18 size Waltham Stem Winding Hunting Cases.

**36 Maiden Lane, New York.**

ORDERS BY MAIL RECEIVE PROMPT ATTENTION.

**BARNES' No. 4 LATHE, For the Heavier Work of Jewelers.**

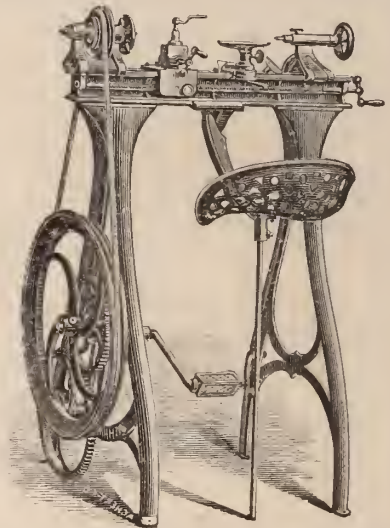

Barnes' Patent Foot and Steam Power Machinery. Complete outfits for Actual Workshop Business. Lathes for wood or metal. Circular Saws, Scroll Saws, Formers, Mortisers, Tenoners, etc., etc. Machines on trial if desired. Descriptive Catalogue and Price List Free.

**W. F. & JOHN BARNES,** 2088 Main Street, ROCKFORD, ILL.

**Watchman's Improved Time Detector WITH SAFETY LOCK ATTACHMENT,**

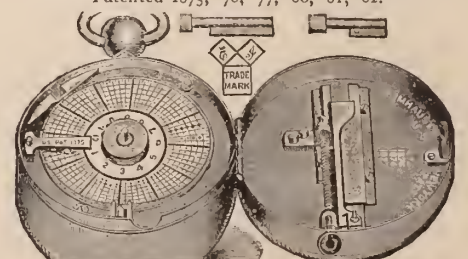

This instrument is supplied with 12 keys. Invaluable for all concerns employing watchmen. It contains all modern improvements, and is far superior to the old style. 1883—At the National Exposition for Railway Appliances at Chicago. The only Medal for the most complete and Perfect Instrument. P. O. Box 2875. Send for Circulars to **E. IMHAUSER, 212 Broadway, New York.**





