



THE JEWELER
AND HOROLOGICAL REVIEW.

* Office of Publication, *

189 BROADWAY, NEW YORK

Digitized by the Internet Archive
in 2016

14 1026





VOLUME XX.

NEW YORK, FEBRUARY, 1889.

No. 1.

THE JEWELERS' CIRCULAR

AND

HOROLOGICAL REVIEW.

OFFICIAL REPRESENTATIVE OF THE JEWELERS' LEAGUE, THE NEW YORK JEWELERS' BOARD OF TRADE, AND THE JEWELERS' SECURITY ALLIANCE.

It is also the Recognized Exponent of Trade Interests.

A MONTHLY JOURNAL DEVOTED TO THE INTERESTS OF WATCHMAKERS JEWELERS, SILVERSMITHS, ELECTRO-PLATE MANUFACTURERS, AND THOSE ENGAGED IN THE KINDRED BRANCHES OF ART INDUSTRY.

SUBSCRIPTION.—To all parts of the United States and Canada, **\$2.00 per Annum**, Postage Paid. To all Foreign Countries, **\$3.00 per Annum**, Prepaid.

All communications should be addressed to

THE JEWELERS' CIRCULAR PUBLISHING CO.,
189 BROADWAY, NEW YORK.

Advertising rates made known on application.

Our Twentieth Anniversary.

WITH THIS issue of THE JEWELERS' CIRCULAR we enter upon our twentieth year of publication and upon our twentieth volume, and it has been deemed appropriate to commemorate the event by some little changes and additions to our usual monthly publication. Our title page indicates in gilt figures the period of our existence, while in our pages will be found a variety of articles, illustrated and otherwise, which tend to make this a specially interesting issue.

THE JEWELERS' CIRCULAR is so well known to the trade that it is almost unnecessary to allude to its long and successful career. Previous to its establishment the trade had no representative journal that was fairly entitled to be called such. There were at the time of the establishment of THE CIRCULAR one or two small, struggling publications printed mainly in the horological interests, which were not a success either as a means of communication between the members of the trade or financially for their proprietors. One of these, *The Horological Review*, was speedily absorbed by THE CIRCULAR and its title amalgamated with that of THE CIRCULAR, and while the latter is the popular designation of our journal, THE HOROLOGICAL REVIEW forms not an unimportant portion of its full title. THE CIRCULAR, as is well known, was established by Daniel H. Hopkinson twenty years ago. Mr. Hopkinson having served in the navy during the war, returned to New York and engaged in the newspaper business, having been for some time connected with the business department of *The Evening Mail*, now *The Mail and Express*. He acquired a very thorough training there in the business part of newspaper work, and having made an extensive acquaintance among jewelers, he was induced to start a paper in their

interests. He had but little capital at the time, but by an arrangement made with Donovan & Londergan, proprietors of a large printing establishment, he was enabled to bring out THE CIRCULAR in good form, the printers for a long time being interested to the extent, at least, of their printing bills. Mr. Hopkinson's training in the daily paper field made of him a good journalist, and as a consequence he put so much energy and enterprise into THE CIRCULAR that it became a success almost from the start. The trade welcomed it with avidity, both because Mr. Hopkinson was personally popular and because he showed a knowledge of what was required and an earnest desire to fulfil those requirements. From a small monthly publication THE CIRCULAR gradually grew to be one of the largest and handsomest specialty papers printed anywhere. In cultivating the retail field for subscriptions Mr. Hopkinson showed a great amount of enterprise, and speedily placed his paper in the hands of a majority of the retail dealers in the country. He was also extremely fortunate in surrounding himself with contributors upon various technical subjects, who were experts in their several specialties, and THE CIRCULAR thus became not only a purveyor of current news transpiring within the trade, but an educational medium prepared by the best thinkers and workers known in the business. This gave it a standing which it has maintained to the present time, making of it the leading paper of its kind in the country. Many of the contributions upon technical subjects which have been printed in THE CIRCULAR during the past twenty years have been published in book form, and have become standard text books in the trade.

When Mr. Hopkinson died some four years ago, a majority interest in THE CIRCULAR was purchased from his widow by the gentlemen, all identified with the trade, composing The Jewelers' Circular Publishing Company. There was at that time a very lively competition for the acquirement of the paper, and at one time it appeared as though it was about to fall into the hands of persons who had no connection with the trade, and who desired to acquire it to make of it simply a money-getting vehicle. It was to rescue it from this fate and preserve it to the jewelry trade, that the gentlemen referred to stepped in and purchased from Mrs. Hopkinson a controlling interest, she still retaining a liberal amount of stock in the company. They had no other object in view than to maintain it, as it always has been, an exponent of the best interests of the jewelry trade and kindred industries. It has since been conducted on the lines developed by its founder, namely, as an instructor and news-gatherer combined, and it is in this light that THE CIRCULAR should be regarded by the trade. The publishers have at times been urged to convert THE CIRCULAR into a weekly publication. To do this would inevitably lead, sooner or later, to the sacrifice of its high character and convert it into a mere news and gossip monger, destroying almost entirely its educational features. In the interests of the trade and for the benefit of the hundreds of young men who are growing up to take the places of the workmen and the business men who now constitute the trade, the publishers have adhered to the plan.

of a monthly publication which should bear substantially the relations to other trade publications that *The Century*, *The Atlantic* monthly and similar magazines do to the daily press. How well they have fulfilled this purpose of providing instruction for the present and the coming generations of workmen, a glance at our table of contents of the volumes already closed will indicate. Almost every branch of the industrial departments of the horological and jewelry trades have been treated upon in serial articles by the best writers in the country, men of known ability both as theoretical and practical experts. At the same time our pages have treated in a broad and liberal manner of the business conditions of the country and of the jewelry trade in general, and recorded such matters of interest as were current at the issue of each number.

With this brief reference to the record of THE CIRCULAR during the past twenty years, we can say that our arrangements for the future warrant us in promising a continuance of those features that have made THE CIRCULAR pre-eminent in the field it has elected to occupy. Our corps of contributors will be augmented, and our facilities for improving the paper added to from time to time, as the requirements of the situation seem to demand. Striving at all times to avoid that which is sensational, we shall seek to give the news as it occurs in the trade, and continue and elaborate the series of educational articles for the publication of which our journal has become so well known. While thanking our many friends for the recognition they have accorded to THE CIRCULAR in the past, we trust that our efforts in the future will be deemed worthy of their continued support and confidence.

Special Announcement.

MR. L. J. MULFORD, who has been connected with THE JEWELERS' CIRCULAR for some time past, and has an extensive acquaintance in the trade, has been appointed Manager of the Jewelers' Circular Publishing Company, to fill the vacancy caused by the death of Mr. Seth W. Hale. Mr. Mulford will hereafter be found at the office of THE CIRCULAR every day, but will also find occasion to keep up his acquaintance with his many friends in the trade. As he is so well known, it would be superfluous to mention the many qualifications which specially fit him for his new field of duty.



A full Index to Advertisements and Table of Contents will be found on Page 7 of this issue.

IT IS a good thing for the retailer to advertise a specialty in these days. Take non-magnetic watches for instance. While it may be true that few persons are brought into such immediate and repeated contact with electrical apparatus as absolutely to require non-magnetic watches, the number of these who are so exposed is large enough to make it of advantage to the watchmaker and dealer to cater for such trade. And besides there is a certain satisfaction for the average wearer in thinking that his watch is protected against all possible influences from this source. When the dealer has made all the necessary preparations and the article is put on sale, it is very natural, if he is enterprising and wide-awake, that he should resort largely to advertising to popularize the novelty, and give the public

the impression that he is alive and fully up with the times. The inevitable result of this is an increase of general sales. His advertising expenses may amount to as much or more than the profits on his specialty, but while he is ostentatiously crying up a single article he is also directing attention to his whole stock, and gaining a reputation for enterprise that is far more valuable to him than any meagre margin of profits. It is from these increased general sales that he can confidently look for a generous return on his investment.

* *

* *

* *

Experience teaches all things, and we have twenty years of it,

* *

* *

* *

“WHILE on my last trip,” said a traveler for a leading manufacturer to the editor the other day, “I overheard a little dialogue between one of my customers and a lady who came into his store to buy. It points a moral that every dealer ought to bear in mind, and on this account will bear repeating. This is what passed between them: *Lady*: I want to look at some new flower brooches; something pretty nice but not too expensive. *Proprietor*: Here is a handsome brooch, newest design, and quite popular now. *Lady*: How much is it worth? *Proprietor*: That is worth \$30, but I can show you substantially the same thing in plate that will look nearly as well for \$10 (producing the article). These I sell more of than I do of the more expensive ones. They answer the purpose just as well. *Lady* (after a moment): Well, I will take this, I guess, it is so much cheaper.” Now, this house used to be a first-class one and catered to a fastidious custom, yet for years they have been committing the folly of cheapening their own goods. Instead of trying to educate their trade up to the highest possible standard of excellence, they have, perhaps unconsciously, been special pleaders all along for the cheap, the shoddy, the imitation article. The best part of their custom has gradually deserted them and they very naturally think there is no demand for fine goods nowadays. But in a neighboring city there is a dealer who has pursued a different line of policy. He always uses his influence to persuade his customers to buy only the best, is careful in selecting his stock and has steadily improved its quality. He never recommends an inferior article that “will look almost as well,” and when the townspeople want something good and substantial, their full money’s worth, they go to him. The result is that while the first house is deteriorating and constantly drawing a poorer and less desirable class of trade, he is building up a solid reputation for reliability and the excellence of his goods, and is attracting to his store people who are more particular about the quality than they are about the price of an article—the most lucrative trade for a jeweler or any other storekeeper. He thinks there is a growing demand for fine goods. And is not the reason obvious?

* *

* *

* *

A STOIC of old would lose patience if he were a jewelry salesman of the present day and had Mr. Call Again on his list. The salesman reaches a city and proceeds about his business, anxious to clean it all up quickly and be off again. In nine cases out of ten, after the usual brief salutation is over and he is prepared to be ardently persuasive over his new line, he will hear such dampening words as these—words that grate on the drummer’s ear: “Call again;” “Come in later;” “Too busy now;” etc. Out he goes a good deal disappointed at the apparent indifference of one of his best customers, only to receive the same cheerless greeting next door. At the end of the day, therefore, our friend of the grip and honeyed eloquence finds to his disgust that he has done little or nothing but open and shut doors and bottle up for future use all his powers of rhetoric. Now, Mr. Call Again uses these goods, in fact he considers them one of his most salable lines, and he was not engaged in



Seth W. Hale

THE UNIVERSITY OF CHICAGO PRESS

largely to advertising to popularize the novelty, and give the public ers them one of his most salable lines, and he was not engaged in

any very urgent business either when the salesman called. Why is it, then, that he postpones looking at the samples? Is there some singular charm in the drummer's manner or countenance, that he wishes these futile visits repeated so often? Many reasons, jocose or serious, present themselves, but none fills the bill so well as that old thief Procrastination, who prompts Mr. Call Again to put off until to-morrow what he could and ought to do to-day. Did it never occur to him that in thus postponing a duty without sufficient cause he was subjecting the salesman or those whom the salesman represents to needless trouble and expense? So widespread is this evil that it frequently takes several days to cover a city which could be thoroughly canvassed in one if salesmen received prompt, business-like treatment from their customers. There is not the slightest reason why merchants should buy less systematically and, we may add, less courteously than they sell. These unintentional discourtesies, these venial sins of omission, can be nipped in the bud by a little care and attention, but if allowed to grow unchecked they become what the jewelry trade is already overstocked with—trade abuses.

**

**

**

Dr. Bucklin's valuable articles on "Mechanical Ocular Defects," a thorough elementary treatise, begin in this number. Subscribe now, and have the series complete.

**

**

**

OUR attention was recently arrested by the very sound observations of a western journal on the custom adopted by some retailers of marking prices on goods displayed in the show window. In answer to the objection usually raised to this custom, namely, that anyone who pauses and examines the window will be pretty sure to come in and ask the price of any article that pleases, and, once in, can be induced to purchase something, our contemporary very aptly says:

"The only trouble about this argument against posting prices is the fact that only a very small percentage of those who may be interested in an article they see will take the trouble to stop and enter, in the face of the possibility of finding the price one that makes its purchase undesirable. The common run of people do not wish to be thought of as growlers at prices asked, and the man who inquires what a thing is sold at and then walks out, is not pleased at the possibility of clerks and bystanders thinking that he is impecunious, or at the possibility of their imputing to him an expectation of getting the goods at an unreasonably low price."

The fact of the matter is, the passer, as a rule, will not take the trouble to come in. He sees something that strikes his fancy and has a half formed resolve to enter and price the article, but this resolve is quickly smothered by the reflection that it will probably cost more than he can afford, or by a natural disinclination to take a few useless steps. But when prices are posted in the window the passer-by can at once determine whether he can afford to purchase or not, and if the price suits he will want to examine the article more closely. This all goes to show how much depends in business upon saving time and trouble for a customer. Fortunes are being built up to-day simply by making it pleasanter or easier for people to buy in one store than in another, though the goods offered may be no better than are to be obtained elsewhere. Large dry goods stores run special stages for the accommodation of their customers. Restaurateurs provide bands of musicians, revolving fans, flowers and other comforts or diversions for their patrons, and of the magic influence such attractions have on the public we see daily illustrations. Of course, we would not advise the retail jeweler to embark in the stage line form of advertising nor to turn his store into a restaurant or a summer garden. These well-known examples of enterprise are mentioned merely to illustrate a commercial principle, based on the

axiom of political economy, that man is prone to satisfy his desires with the least possible effort. If, then, as seems probable, the price label in the show window is a time-saving device, and by satisfying the inquirer's doubt beforehand, predisposes him to enter the store when otherwise pride, laziness or other considerations would restrain him, the custom is worthy of more general acceptance. Let every retailer try both methods for himself and determine which produces the best results.

**

**

**

SAYS the *Decorator and Furnisher*: "The elegant styles in which jewelry is now set are suggestive of decorative modes of treatment with other materials and for other purposes. Types of ornament of classic and other origin, though admitting of numerous modifications, are too much adhered to. With the pliable precious metals, however, every encouragement is given to break away, in the search of novelty, from accepted forms, resulting in new classes of ornament, including a variety of forms of flora adapted for reproduction. Jewelers have succeeded in reviving the demand for silver ornamentations. Silver is more extensively employed for dinner and tea ware, frames of boxes and mirrors and borders of toilet tables, which latter, when heavily chased, are now slightly oxidized; also for caskets, small clocks and calendar frames." It ought to cheer the jeweler's heart and even tickle his vanity a little, to read the many complimentary notices like the above which fall under THE CIRCULAR'S editorial eye. The long Circean spell is broken. Who dare say now that jewelry is unpopular?

**

**

**

THE November summary of imports and exports compares favorably with last year's schedule for the same month. Imports of rough and glazier's diamonds amounted to \$24,656 as against \$26,330 for 1887; clocks and clock materials to \$50,451 as against \$48,370; watches and materials to \$145,573 as against \$161,914; jewelry to \$64,184 as against \$81,241; precious and imitation stones to \$668,947 as against \$539,150. Exports of watches and clocks increased 72 and 10½ per cent respectively, while in jewelry there was a decrease of 12 per cent. An increase of 16 per cent. in exports of plated ware is offset by a decrease of about 9½ per cent for the eleven months of the year. A fair general average, but not showing that degree of improvement in our export trade which might reasonably be expected.

**

**

**

We are almost old enough to vote.

**

**

**

A FRUITFUL field for the jeweler to-day are the numerous little articles of household use that everybody likes to have as attractive as possible. Scarcely anything is too humble for his notice. By beautifying little trinkets, however insignificant they may be in themselves, he rescues them from the commonplace, and thus creates a new demand for them. Umbrella and parasol makers tell us that the jewelers have done more to improve their business than all other agencies combined. Some years ago, they say, a \$10 umbrella was a thing unheard of, so prosaic and unattractive was this indispensable article then. But the jeweler's Midas touch has transformed it into a thing of beauty, and now people of means are willing to pay several times that sum for one, because it has become an ornament, while its usefulness is in no wise impaired. The silver handles and tips in endless variety that have been added, have educated the taste, and the consequence is that all the materials

which enter into the manufacture of the umbrella must now be of the finest quality. What jewelers have done for the umbrella and the parasol, they have also done for prayer books, purses, card cases, pocket knives, and the thousand and one little necessities of the person and the home. Under their skilful treatment these lose their lifeless monotony, are no longer in the dull catalogue of common things, and can properly be classed among works of art. If the manufacturer wishes to strike the popular vein, let him seek for that happy combination of utility and beauty which is certain to please because it is useful as well as ornamental. With this end in view he should keep the run of the fancy goods stores and bazaars that are constantly offering something new in the way of knick-knacks, toilet articles and minor conveniences in general.

* * * * *

Chas. S. Crossman's interesting articles on the history of the watch case and clock industries of the United States will run for two years more.

* * * * *

FROM the Patent Office report of inventions for the quarter ending June 30, 1888, we learn that there were issued during that time seven patents on jewelry, eleven on clocks or parts thereof, ten on spectacles and eye-glasses, two on timepieces, seven on watch cases and twenty on watches, parts of watches or methods of manufacturing the same. By far the greater activity of invention is, of course, found in watchmaking, which to-day is, perhaps, our most remarkable industry in the ingenuity and activity it calls forth and so abundantly rewards.

* * * * *

Compare our first with our last, and see what comes of small beginnings.

* * * * *

WHAT a conception of the growth and magnitude of our country is given by the watch factories and the rumors of watch factories with which the air is rife in these days! There seems to be no limit to the enterprise. Previous failures are no discouragement. From the plains of the far West comes the hum of the busy wheel; and in the East, under the very eaves of the old factories, new rivals spring up. Rochester is about to embark on the troubled sea of watchmaking. Atlanta's pride is stirred to emulation by the activity of her Northern sister cities, and on the ruins of a former factory another bids fair to rise like the Phoenix. The wonderful vitality of this branch of industry can only be accounted for by the enormous and constantly increasing domestic demand for watches, which, in itself, is a pretty good indication of general prosperity.

* * * * *

'EXCELSIOR'S' "How to Test for Magnetism," etc., on another page, is worth a year's subscription to any watchmaker.

* * * * *

WE had something to say in our last issue about the danger of underestimating the injurious effects of magnetism on watches, and advised any of our readers that had been misled into a contemptuous attitude on this subject to give it the careful attention to which, from its growing importance, it is entitled. In further confirmation of the stand we then took, we are pleased to refer our readers to the very able article on "How to detect magnetism in watches in the shop, on the cars, and on the person," by "Excelsior," a writer whose name is a household word to the watchmakers of this

country. It is a clear and conclusive exposition of the subject, and ought to enable any watchmaker who studies it thoroughly not only to settle this question forever in his own mind, but to put better and more accurate timekeepers into his customers' hands. Besides, if he be a stranger to the science, it will initiate him into one of the most fascinating and profitable studies known to modern times.

* * * * *

The years may come, the years may go, but we go on as ever.

* * * * *

A REMARKABLE instance of the elusiveness of taxable wealth in the form of personal property is gleaned from the reports of the tax assessors of the State of Ohio. Comparing the returns for 1882 and 1887, we find that the number of watches taxed in those years was as follows:—

Number of Watches.	1882.	1887.
Ohio	118,286	114,631
Hamilton county	9,283	8,659
Geauga county	845	922

Commenting on this astonishing dearth of timepieces, a well-known economist says:—"As for Ohio watches, they are certainly not open to the accusation so often brought against French clocks, that they will 'never go.' Ohio watches certainly can and do 'go,' with a rapidity and steadiness not often equalled." This throws a gleam of light on a dark subject. Is it not evident that Mr. John C. Dueber consulted these returns before deciding to remove his works from Newport to Canton? Surely tax assessors never lie, and they tell us there are only 115,000 watches in the State. Hundreds of thousands of the prosperous citizens of the "Buckeye State," therefore, must be without watches; enough to absorb his entire product for at least a year. What an opportunity! Ohio, then, is the Mecca of the watch industry, and to all the promoters and inventors of the East, whose teeming ideas are seeking realization, we would say, "Go West; Ohio needs you." But—perish the doubt—perhaps the figures are not correct after all.

* * * * *

See the handsomely illustrated serial on the Marfels Watch Collection at Frankfort, on the Main.

* * * * *

THE recent failure of several old-established jewelers points a moral that those now in the hey-day of prosperity would do well to remember, and that is, the imprudence of men of advanced age, already possessed of a competence, risking the accumulations of years in an unequal struggle with younger and more enterprising competitors. The world moves fast in these days, and the successful methods of to-day become antiquated to-morrow. The energy of youth is soon exhausted. Unconsciously the merchant gets out of harmony with his surroundings; he "loses his grip," as the saying is, and the XIX. Century Express flies on without him. But the sad part of it is, he doesn't usually realize that he has been left. Money-getting with him has become a passion, which even money-losing seems powerless to check. False pride counsels against retirement. The habits of years have a tendency to perpetuate themselves. He is over-confident, thinks himself the equal or superior of the rising generation, and boldly throws down the gauntlet. Of course, in nine cases out of ten, he is worsted, fails disastrously, or saves a mere pittance from the wreck of his fortune, and is left to drag out a weary and disappointed age, when peace and plenty might have been his. Why not let well enough alone? The chances being so overwhelmingly against them, why will merchants obstinately block up the way of those that come after, and let the "hungry generations tread them

down?" It is certainly wiser and more dignified to get out before you are crowded out. We are aware that this sounds very hard and cruel, but it is a cruel *fact*.

* *

* *

* *

We survey with pride our fair record of twenty years.

* *

* *

* *

IN Paris they have a custom which might seem a trifle odd to the average American storekeeper, but which can hardly fail to have a good effect on trade in general. Whenever a Paris shopkeeper advertises goods "at cost," a Government official, detailed for the purpose, promptly swoops down upon him and makes a careful inspection, in order to satisfy himself that the merchant is carrying out what he advertises. If the latter is detected in fraud, an adequate punishment is promptly meted out to him. Some of our American storekeepers would doubtless find this rule a little severe; but what a wholesome effect it would have in cutting down the number of so-called bargain (?) sales!

* *

* *

* *

Call the attention of editors of your local papers to "Elsie Bee's" "Rambles among the Jewelers," and have the items reprinted. It will increase your trade.

* *

* *

* *

A FEW years ago the jewelry trade was suffering from the indifference of the fashionable world. From mouth to mouth the word passed that jewelry was no longer in taste, because, forsooth, some leader of the fashion forgot to wear her earrings or her bracelets on some brilliant social occasion. The newspapers innocently spread the error through the careless poll-parroting of their reporters and fashion writers. The boycott continued, and the poor jeweler was at a loss how to stem this rising tide of prejudice that seemed destined to ruin his business. At length thoughtful minds in the trade devised a way to counteract this damaging influence, and, in fact, to turn it into a power for good. Means were ready at hand, and all that was needed was concerted action and perseverance on the part of the individual members of the trade. According to the plan which was then adopted, THE CIRCULAR began the publication of a department headed "A Lady's Rambles Among the Jewelers," devoted to the description, in brief paragraphs, of the latest and most popular styles in jewelry, silverware and kindred lines. It was the intention, further, that advance sheets of these items should be sent to retailers in different parts of the country interested in the work, who, by reason of their local influence, might have them published regularly in their own town or county papers, each working in his own limited field for the advancement of the interests of the whole trade, as well as of his own. The fashion items that appear in THE CIRCULAR are in such form as to be readily available for publication in daily or weekly newspapers under the heading of "Novelties in Jewelry," "Of Interest to Ladies," or under any regular department that is devoted to fashions in dress, etc. To the compilers of such special news, or to the editor in search of fresh and interesting "fill-up" matter, they are a positive boon. All that is necessary, then, to secure their publication is that retail jewelers of good standing should bring them to the editors' notice. Much has already been accomplished in this way, as those who scan the columns of our leading dailies must well know. Diamonds, watches and jewelry are now familiar subjects in the news and novelty columns. The debt the jewelry trade owes to the journals that represent it, for this most important change of base in the daily press, has not yet been realized. Slowly but surely the agencies are at work, working without cost, which are bound to bring back the golden age of prosperity, and silence utterly and forever, we hope,

the cry that jewelry is unfashionable. Already a goodly number are pledged to the work, but the cause is large enough to enlist the services of the whole trade. The advance sheets of these items, which are struck from the press about the 20th of each month, will cheerfully be sent gratis to any retailer who can place them advantageously or directly to any editor who will re-print them. In response to THE CIRCULAR's call for volunteers, the following well known retailers have agreed to co-operate with us in bringing these fashion notes before the public:—D. H. Buell, Hartford, Conn.; M.W. Galt, Bro. & Co., Washington, D. C.; Thos. V. Dickinson, Buffalo, N. Y.; Chas. S. Stiff, Little Rock, Ark.; Ben Guider, Vicksburg, Miss.; J. H. & W.W. Williams, Macon, Ga.; E. S. Ettenheimer & Co., Rochester, N. Y.; F. L. Davies & Bro., Nashville, Tenn.; E. W. Button & Co., Bridgeport, Conn.; J. B. Bliss, Atchison, Kan.; W. C. Bryant & Co., Danbury, Conn.; Becker & Lathrop, Syracuse, N. Y.; Buker & Skinner, Rockford, Ill.; Geo. W. Biggs & Co., Pittsburgh, Pa.; E.H. Ayres, Elmira, N. Y.; C. H. Case, Hartford, Conn.; O. E. Curtis & Bro., Decatur, Ill.; Geo. W. Chatterton, Springfield, Ill.; Henry Dehnel, Sandusky, O.; Durant & Rogers, Lowell, Mass.; J. E. Ellis & Co., Toronto, Canada; F. M. Finch, St. Paul, Minn.; A. B. Griswold & Co., New Orleans, La.; Jacob W. Grubb, Wheeling, W. Va.; Giles, Bro. & Co., Chicago, Ill.; Hope, Bros. & Co., Knoxville, Tenn.; A. M. Hill, New Orleans, La.; Geo. H. Lees & Co., Hamilton, Ont.; Ackerman, Bicker & Manvel, New York; W. L. Hoskins, Owego, N. Y.; A. L. Burbank & Co., Worcester, Mass.; Wm. Kendrick's Sons, Louisville, Ky.; R. C. Green & Son, Pottsville, Pa.; Geo. H. England, Holyoke, Mass.; David Rosenberg, Rochester, N. Y.; Gus. A. Bahn, Austin, Texas; L. S. Stowe & Co., Springfield, Mass.; J. Stuart MacDonald, Baltimore, Md.; Richard Smith, Newark, N. J.; C. F. Rudolph, Wilmington, Del.; S. Thomas, Jr. & Bro., Charleston, S. C.; The Jaccard Watch & Jewelry Co., Kansas City, Mo.; R. B. Thayer, Memphis, Tenn.; Leyson & Turck, Butte, Mon.; Hight & Fairfield, Butte, Mon.; P. H. Lachicotte & Co., Columbia, S. C.; W. T. Marcy, Indianapolis, Ind.; J. N. Mulford, Memphis, Tenn.; David Prager, Fort Scott, Kan.; Palmer, Batchelder & Co., Boston, Mass.; E. S. Pendexter, Portland, Me.; Robinson Bros., Council Bluffs, Ia.; Ryan & Barrows, Middletown, Conn.; J. P. Steinman, Allegheny, Pa.; Safford & Lunt, Newburyport, Mass.; M. S. Smith & Co., Detroit, Mich.; Stilson & Rounds, Anniston, Ala.; F. W. Sim, Troy, N. Y.; Sweeney & Coombs, Houston, Tex.; C. H. Trask, Galesburg, Ill.; E. M. Trowern, Toronto, Canada; S. G. Twambley & Son, Biddeford, Me.; S. C. Tappin, Troy, N. Y.; Taintor & McAlpine, Easthampton, Mass.; Jules, Wendell & Son, Oswego, N. Y.; Wtolers Bros., Rochester, N. Y.; A. C. Taylor, Cedar Rapids, Ia.; Charles H. Lamson, Portland, Me.; Brown & Grant, East Saginaw, Mich.; Knepfly & Son, Dallas, Texas.

Free Hand and Mechanical Drawing.

BY EXPERT.



WHEN MIXING tints for sky and broad sheets of water, it is well to prepare more than we deem absolutely necessary, as it always produces spottiness to make repeated combinations of colors. Another thing about sky tints is to keep them pure, that is, free from such tones as suggest the earth—in fact, dirty looking. We see so many skies which has a look as if the same pencil had been used for trees, showing absolutely foul green tints. In painting skies the outlines of clouds should be marked so that we can readily locate our colors and not have to hesitate. Although I told how to lay transparent tissue paper over a raw sketch to facilitate working on it, still it is much better to do all we can in the first painting; this is true for many reasons; conspicuous among these are few colors are perfectly opaque. In painting the sky to our outline spoken of above, we would mix white with dark cobalt blue, laying the color on rapidly down to the edge of the clouds, which are sup-

posed in such a sketch as the above to be painted in with pure white to the rounded outline. When writing on cloud painting, or, indeed, sky painting in all its details, I feel as if I could not say enough, the subject is so exacting. Let any person visit our yearly exhibits at one of our larger art galleries, and out of all the landscapes shown there will not be more than a half dozen good skies. The pupil should make a practice of cloud and sky sketching alone, or at least if trees or buildings are painted at the same time it is supposed they are secondary in importance. One fault common with many artists is painting the edges of white clouds either too sharp in contrast to the blue, or they let the blue blend too much with the white. We see few absolutely white clouds in nature, they usually partake more or less of a yellowish or reddish hue. In such sketches as we have in hand yellow ochre or light red answers as well as could be desired to blend with white. While on the subject of cloud painting, it will be well to add that no matter how sharp and decided the contrast of a white cloud may seem to the eye when viewed in nature, in the painting to represent it there must be a blending at the edges. Pure white or white modified with yellow or red can only be used a little way back from the extreme edge. The upper edge of the sky in the picture can be painted with a little ivory black added to the blue and white, while the portion which approaches the horizon needs a little addition of red. In the sketch we use light red; in the final painting rose madder or even vermillion can be employed. The distant hills are painted in with white, cobalt blue and light red, almost the same tint as we use for the darker clouds. The nearer bluffs at the left of the picture are painted darker in tone by adding ivory black. The parts which catch the light being painted with subdued red. In the nearer portions a little green (made by mixing yellow ochre and ivory black) can be worked in to give the appearance of trees such as cover a mountain side. The management of such details can only



be acquired by study and practice. The trees at the right are painted in with yellow ochre and black, working in the shadows of the branches in the center of the trees wider than we intend to be shown in the final painting. The roadway and foreground is painted in with light red, white and yellow ochre making out the shadows as much as possible, with light red and black to keep them warm. I might as well notice a fault common to most all young artists, which lies in painting their trees too green. One of our most successful English landscape painters, in lecturing to his pupils on judicious use of colors, remarked on composing greens: "black is blue enough; if not, use blue." It is only in the final painting we should have recourse to bright greens. The water is painted with sky colors, except the tone is a little darker. The strongest characteristic of water in the distance is bright, horizontal marking made with the lightest of our sky tints. In the foreground, or rather middle distance, these horizontal markings are best imitated by "scumbling," which is accomplished by a brush loaded with thick color passed rapidly over the surface when it is imperfectly dry. Although this technical manipulation belongs strictly to second painting, still in sketching and first painting such methods can be successfully introduced to great advantage. In first painting it is well to work with rapidly drying colors, so that we can have recourse to such little

tricks of art. The best material to promote drying is for the darker colors to use the common japan drier of the shops, and in the lighter and more delicate tints sugar of lead, which comes ready prepared in tubes. Although it must be confessed that the use of dryers of any kind are not to be commended as a rule, still some colors are such abominable dryers, some kind of aid is absolutely necessary, as, for instance, rose madder and the deeper purples compounded from it. As I wrote in a former communication, it is very difficult to convey ideas of technical details by writing, or any methods of illustration so far in use. I feel this particularly at the present when I wish to describe how to paint a foreground in the first painting. This rock is, as we may say, in a state of half tone and tint. To illustrate, suppose we are painting a rock in the foreground; in the first painting we do not attempt to express either the highest lights or darkest shadows; these are left for the second and even third paintings. The great point is to determine exactly how much we should leave for these subsequent paintings. In painting rocks we must steady their formation and characteristics; these are principally stratification and cleavage. If an artist is intending to adopt landscape painting as his special branch of art, he should study a certain amount of geology and also botany, so as to be able to know and portray the peculiarities and characteristics of the objects he is painting. To resume the special treatment of rocks in the foreground: In dead coloring we paint the general form and color; the highest lights are not shown, or the details made out. Rocks are always more or less broken, hence I spoke of the cleavage or form of fracture; this is always characteristic of the group (geologically speaking) to which they belong. The lightest portions of the rocks shown in the little drawing above, would not in the first painting be as sharp or bright as they would in the second or finishing touches. Lichens are always found on old rocks and go far to add to the picturesque effects of such objects. These should also be studied and a technical method adopted to express them both in color and form. In adding to the depth of shadows, form and structure should be considered as much in painting up the high lights. There is not a more attractive feature in art than rendering distinctly objects in half light; the subtle reflections give exquisite relief. A few characteristic touches to deepen a broad shadow, like the added brighter lights show the hand of the skilful artist. Shadows are usually deepened by transparent glazes, while the high lights are applied with thick opaque color. I will make a brief *resumé* of the order of painting a sketch like the one above. For the sky mix cobalt blue ivory black, and white as the judgment directs; near the horizon add a little light red and more white. For clouds use white, yellow ochre and light red; shadows of clouds white, ivory black and light red. The water is painted with same colors. Trees, ivory black, yellow ochre and white. In foreground greens use yellow ochre and cobalt blue. For the rocks use ivory black, light red, yellow ochre and white.

ARTIFICIAL JEWELS.—It has long been known that in some specimens of bamboo a round stone is found at the joints of the cane. This is called "tabesheer," and is supposed to be deposited from the silicious juices of the cane. Another curiosity of this sort is the "cocoanut stone," found in the endosperm of the cocoanut, in Java and other East India islands. It is, according to Dr. Kimmins, a pure carbonate of lime, and the shape of the stone is sometimes round, sometimes pear-shaped, while the appearance is that of a white pearl without much luster. Some of the stones are as large as cherries and as hard as felspar or opal. They are very rarely found, and are regarded as precious stones by Orientals and charms against disease or evil spirits by the natives. Stones of the kind are also found in the pomegranate and other East India fruits. Apatite has also been discovered in the midst of teak wood.



* A Complete History of Watch and Clock Making in America.

[By CHAS. S. CROSSMAN.]

Number Thirty.

Continued from page 59, January, 1889.

NEW YORK STANDARD WATCH CO.

THE ABOVE named watch company was incorporated August 13, 1885, under the laws of the State of New York, with a capital stock of \$400,000 now paid in. The names of the trustees are as follows: A. Dutenhofer, President; Wm. C. Roberts, Vice-President; J. M. Hallows, Secretary and Treasurer; E. Spicer, A. B. Smith, Edw. D. Hicks, Edw. H. Quick. The first business of the company was to secure an eligible site on Jersey City Heights and erect a very commodious factory building, which, so far as room is concerned, has a capacity of not less than 1,500 movements per day. W. W. Hastings was appointed to the superintendency, and under his management movements were commenced and pushed to completion, and put on

the market early in 1888. It is an 18 size movement, the chief feature being the escapement, which is a straight line lever with a worn escape wheel pinion, this being the patent of R. J. Clay. They are all quick train and open face. The company are also making cases in white metal, silver and gold filled, and sell their product as complete watches. The main office is located at No. 83 Nassau street, New York City, which is presided over by F. G. Miller, the general selling agent of the company.

The enterprise shown by this company, especially in the matter of putting a watch so different in construction from any other on the market, is certainly most commendable, and should the merits of the watch prove as great after years of actual service in the pockets of the wearers, as is claimed for it by the company, who have shown their faith in it by the investment of a large capital, their success is beyond a doubt. We may say it is an assured fact.

THE WICHITA WATCH CO.

This company was organized under the laws of the State of Kansas in the fall of 1887, with the following named gentlemen as officers and trustees: J. R. Snively, President; Geo. Blackwelder, Vice-President; H. W. Lewis, Treasurer; Irvin Stratton, Secretary; Wm. Greiffenstein, R. E. Lawrence, Irvin S. Walton, John McCormick, O. Martinson and Lafayette Simpson. The capital stock was placed at \$250,000, and was mostly taken by citizens of Wichita. A site for a factory building was selected, and a very nice, commodious factory erected which the company now occupy, and are preparing to go ahead with the manufacture of watch movements, which they expect to have on the market in a few months. Of their prospective history

we will not speak; we prefer to wait until it becomes actual, and so have but little to say of this company at this time.

This will close the history of that part of the watch industry which relates to movements only. And after briefly reviewing the history of the manufacture of watch cases "in America," we shall proceed to the remaining series of historical articles which will refer especially to clocks and marine chronometers.

We find that branch of the industry which relates to the manufacture of watch cases a rather extensive one, and would not feel that we had done the subject justice if we did not go somewhat into its history, but we shall not attempt to go so fully into all the historical details of this branch as we did into the others. Chronologically speaking, Philadelphia seems to have rather taken the lead in the industry of watch case making, and in the next issue of THE CIRCULAR we shall take up the history of this branch of the industry there.

(To be continued.)

CINCINNATI

[FROM OUR SPECIAL CORRESPONDENT.]

POST-HOLIDAY NOTES AND INCONGRUITIES.

CINCINNATI, Jan. 19, 1889.

The telephone assisted Ezekiel Shott, a jeweler on Fifth street, early in the month to escape from being a victim to a well-planned swindle. A couple entered the store early one morning and selected a large quantity of jewelry, when one of them, giving his name as McNamara, asked Mr. Shott if an order from the Queen City Electric Light Company would be accepted in payment for the goods, and on being answered in the affirmative, gave an order for the goods to be laid aside. The next morning he returned bearing an order written on a letter-head of the company, signed by the Secretary. The proprietor was absent and the clerk on duty doubted the genuineness of the order. Stepping to the telephone he called up the Electric Light Company's office, and was informed that no such order as he held had been issued. On turning from the machine he found that the would-be swindler had departed.

On Wednesday, January 9, the Wholesale Jewelers' Association elected the following named gentlemen as officers for the ensuing year: President, Aaron Herman; Vice-President, S. M. Peck; Secretary and Treasurer, Joseph Becker; member of the Board of Trustees, John C. Dueber. The election was subsequently celebrated by a social time at the Burnett House.

One of the ultra-fashionable organizations of this city is the Cincinnati Pottery Club, which was an outgrowth of the celebrated Rookwood pottery. Its officers recently elected are: President, Miss M. Louise McLaughlin; Secretary, Miss Clara Newton; Treasurer, Miss Alice B. Hollabird. The members are: Miss Francis M. Banks, Mrs. S. B. Camacho, Mrs. Geo. Dominick, Mrs. Walter H. Field, Miss Laura A. Fry, Mrs. A. H. Hinkle, Mrs. E. G. Leonard, Mrs. A. H. Lewis, Mrs. Alex. H. McGuffey, Mrs. Elizabeth Nourse, Miss Helen Peachey, Mrs. Estes G. Rathbone, Miss Julia Hall Rice, Mrs. S. G. Sykes and Mrs. H. C. Yergason.

Samuel Fernstein and Max Wittenberg, two jewelry peddlers left Cincinnati the first of the year for a five days' trip through Southern Indiana, and neither of them has been heard of since. Fernstein had a \$700 stock with him. Wittenberg recently came from New York. Foul play is suspected.

James K. Bingaman, doing a small business as a jeweler at 309

Vine street, made an assignment one day last week to Daniel R. Broh. His liabilities are \$2,400, his assets \$2,200. Bingaman claims dull business as the cause.

Louis Hummel said to your correspondent to-day that the Retail Jewelers' Association, recently organized in this city, is just now very quiet. The members are waiting to see what concessions the eastern dealers are going to make to them.

Samuel Fox, of Fox Brothers, diamond importers, leaves this week for a six months' business trip to Europe.

During the holidays a woman entered the jewelry store of Duhme & Co., and inquired of Mr. La Boiteaux if it were true that all the jewelry stores raised their prices just before Christmas. Another credulous lady asked a few days ago if the prices had had their usual post-Christmas reductions.

"You see (hic) that wash?" asked a gentleman, sah, from Kentucky a few days ago of one of the Cincinnati jewelers, at the same time holding out in his unsteady hand an old Cheap John affair from which a thin wash of gold was long ago worn. The jeweler assented. "Well, sah, that's (hic) th' same wash given me (hic) by my brother when he was dyin' on the field of ba'l, on the field of ba—'skuse me sah, on the field of ba'l. He gave it t' me as a momentum, and s'help me gracious I'm goin' to keep it." Saying which, without making known any business whatever, the mellow Kentuckian staggered out of the store.

One of the regular customers of a Cincinnati jeweler has a patriarchal beard, the lower part of which he braids, runs it through one of the buttonholes of his vest and uses it for a watch guard.

Ever notice how rapidly an object will increase in value provided some responsible party has had temporary possession of it and lost it? A young lady walked into a prominent jewelry establishment in this city some time ago with a small pin which she wanted fixed. The pin was ornamented with a small stone. One of the firm took the pin from the young lady's hand to examine it, when the stone, which was loose, dropped to the floor and disappeared. It was thought it had gone down through an old floor register into the debris of the workshop below. Instantly the young lady was disconsolate, and her grief increased in proportion as she grew confident that the jewel was hopelessly lost. "That was a beautiful ruby," she exclaimed, "given me by my mother. Its value must be very great." "You are sure it was a ruby?" inquired the anxious jeweler. "Sure? Of course I'm sure. It cost my father a great amount of money;" and then to make the situation more interesting she began to cry. Another member of the firm came up at this juncture and inquired the reason for the disturbance. "This gentleman has lost my ruby," sobbed the young lady. "Ruby, was it?" asked the newcomer, as he began to search the floor. Suddenly he stooped and picked up the lost treasure. The young lady identified it. It was a garnet worth about twenty-five cents.

Annual Meeting of the Jobbers' Association.

THE Fourth Annual Meeting of the National Association of Jobbers in American watches, which was held January 15, in the spacious and elegant directors' room of the Mutual Life Insurance Company, was called to order at 10:30 A.M. by President H. F. Hahn, of Chicago. On calling the roll it was found that 92 members were present in person, and that 25 were represented by proxies.

After a short address by the President, reviewing the course of events during the past year, and offering some practical suggestions for the future, which were received with applause, the meeting was declared open for business, and the regular order was taken up. The

minutes of the last meeting were read and approved, and the report of the secretary and treasurer, showing the present membership to be 206, and the balance in the treasury \$3,251.63, was then read and declared approved. The resolutions which had been adopted by an informal conference of jobbers, held on the preceding day, were then read, and being afterwards taken up by sections, were adopted, with some modifications, and the following conference committee was appointed to wait upon the co-operating manufacturers and present them:—C. Hellebush, of Cincinnati, Chairman; S. Oppenheimer, E. S. Smith and M. Lissauer, of New York; Otto Young and L. W. Flershem, of Chicago; D. C. Percival, of Boston; Geo. Goddard, of Pittsburg; A. Kurtzborn, of St. Louis. During their absence a recess was taken.

The meeting was again called to order at 5 P.M., when the Conference Committee reported that the manufacturers accepted most of the suggestions made to them, but referred a few back for further consideration. Debate upon these was begun, but, owing to the lateness of the hour, the meeting was adjourned until 10 o'clock of the following day.

The following morning the debate was continued, and after thoroughly discussing the questions, the same committee was instructed to again confer with the manufacturers, and a recess was taken until 2 P.M.

At the afternoon session, the committee reported the result of their meeting with the manufacturers, which was adopted with great applause, being entirely satisfactory. The election of officers was then taken up, and the following officers were chosen for the ensuing year:—President, H. F. Hahn, of Chicago, Ill; Vice-President, Ira Goddard, of New York City; Secretary and Treasurer, J. H. Noyes, of New York City; Members of the Sub-Committee, E. S. Smith and David Keller, of New York; L. W. Flershem, of Chicago; Alternates, Henry Ginnel and Leopold Stern, of New York; and Otto Young, of Chicago.

After passing a vote of thanks to the officers for their services, and to the insurance company for their courtesy and liberality in allowing the use of their beautiful room, the meeting adjourned. As will be seen by the list of members present, all parts of the country were well represented, and the sentiment in favor of continuing the Association was practically unanimous. The spirit of harmony which prevailed augurs well for the prosperity of the coming year to all parties interested.



[FROM OUR SPECIAL CORRESPONDENT.]

THE GOLD FIELDS OF THE TRANSVAAL—NEW FACTS ON THE DISCOVERY OF THE KIMBERLEY FIELDS—FORTUNE'S TWO EXTREMES—THE SOWER NOT ALWAYS THE REAPER—CONSOLIDATION.

KIMBERLEY, December 2, 1888.

A deep interest, verging upon enthusiasm, centers in the development of the gold industries of the Transvaal and adjacent territories. Week by week there is incontrovertible evidence of the existence of very extensive deposits of the precious metal. It is no mere platitude to say that these fields are likely to prove amongst the richest, if not the very richest, the world has ever known. Official returns

and reports and newspaper accounts are now available, and the most sceptical must now admit the importance of these gold producing centers in affecting the output in the future. The last few days there has been quite a "boom" in gold stocks, owing to heavy orders from London and the Continent.

Everything pertaining to the South African diamond mines seems to possess a significant interest to the trade. The history of these fields has indeed been wonderful, and if related in strict accuracy would read like some wild romance. From a desert previously unknown to civilized men, stones realizing in Europe over seventy million pounds have been unearthed in about a score of years. The Cape Colony and Natal were almost on the verge of bankruptcy previous to the discovery of diamonds in the year 1867. Men had lost hope in the future of the country, and many left for Australia and other British colonies. Just about this time a simple Irishman named O'Reilly, engaged in peddling among the natives in what was then termed the interior, stopped one night at the house of an equally simple Dutchman named Van Niekirk, living in a wild, untravelled region. O'Reilly saw the children of his host playing with what they termed pretty *kliips* (stones). One of these pebbles threw out strong dazzling light, and the peddler examining it said he thought was of some value. At this Niekirk laughed at him in the way Dutch folks can laugh and ridiculed the idea. However, O'Reilly took the stone with him to the nearest town and showed it to some friends, who laughed at him because he said he thought it might be a diamond. O'Reilly with the stone then wrote his initials on a pane of glass, but this was not considered any proof whatever that the stone was a diamond. Would not a common flint do the same? A bystander got one and it was tried. The gun flint scratched the glass almost as well as the reputed diamond, and then the conceited fellows laughed at O'Reilly. One of the men actually took the stone and threw it out of the window in disgust. But the Irishman picked it up and cut a tumbler with it. Even then no one in the district would believe that the stone was a diamond, and poor O'Reilly became a subject of ridicule. In the small city of Grahams-town there lived a somewhat celebrated Roman Catholic Bishop (Ricards), and to him the stone was ultimately sent. The Bishop had evidently seen diamonds before, for he pronounced it to be a stone of $22\frac{1}{2}$ karats. But even then the people around would not believe it, and stated that the Bishop knew nothing about the matter. The stone ultimately got into the possession of Sir Phillip Wodehouse, then Governor of the Cape Colony, and from this date the excitement commenced and has continued ever since. As O'Reilly now passes from view, it is well to remark that it was to his dogged perseverance that the present generation owe the discovery of diamonds, and it seems that no reward has ever been given to him or any money acknowledgment made to him by governments of South Africa. He is now working for his own livelihood in the Transvaal. When the news got abroad the natives of the district brought stones to the white farmers and traders which proved to be diamonds, but had never been regarded of value by the natives. They thought from the desire of the white man to purchase that the stones possessed some talismanic power. Soon there was a rush, and the excitement grew until a stone was found which was sold eventually for £11,200, and is now in the possession of the Countess of Dudley. This created a great furore, though there were many sceptical people. It was actually set afloat that diamonds had been obtained from Brazil by interested parties in Africa, so that by this means they might dispose of their properties at a high figure, and doubts were expressed in the very highest quarters as to the genuineness of the finds. A well-known London firm sent out an expert, and this authority reported that there were no diamonds in the country, and that there were no indications of the existence of precious stones. Letters to this purport appeared in the principal London newspapers, and geologists and experts decided that South Africa was non-diamondiferous. It is worthy of remark that no less an authority than the late Sir Roderick Murchison declared it was

impossible that diamonds could exist on the Griqualand West strata. Since then over seventy million pounds' worth of diamonds have been shipped from these shores. Geological experts have been completely at sea, too, in reference to the gold deposits of the Transvaal. Years ago these scientific gentlemen admitted that the soil was auriferous, but ridiculed the idea of payable gold existing. Actual results to the present show that an immense area of country is rich beyond comparison with other gold producing places, and that the production in South Africa during the next decade is certain to materially affect the world's supply of the precious metal. The history of the development of the diamond industry could be made very interesting, but space forbids. The famous Kimberley Mine was discovered almost by accident. The farm upon which it stands had failed to find a purchaser at £700. There were on it a number of mimosa trees, and one day a lazy young man was reclining under one of them. Aimlessly scratching the ground with his pocket knife he brought to the surface a beautiful stone. Soon a rush commenced, and since then diamonds realizing nearly twenty million pounds have been taken from the mine.

Turning, however, to the present state of the diamond industry, it is clear that everything transpiring in relation to it points to the fact that experience in management and economical working are placing the larger companies in a substantial position, substantial enough, indeed, to cast in the shade many of the leading industries of the present century. This, however, is not the object of those who have cast in their lot, not to speak of capital, into the working of the Kimberley blue ground. They have pursued the development of the mines on far broader principles, and by their unflagging energy and tenacity of purpose have not only given an impetus to trade in one of England's most important possessions, but they are in the enviable position of being able to supply the world with the precious stone in its most perfect form. In addition to this, the protection of the diamond traffic has exercised the minds of the largest holders and with the most satisfactory results. It is obvious that some reform was needed in order to place the control of the output in competent hands, and still more clear that the steps taken in that direction were not in any way premature. Some six years have elapsed since the idea of consolidation was first conceived; and although the process was a tedious one and not unattended with serious difficulties and strenuous opposition, that object has now been accomplished in so far as the Kimberley Mine is concerned. The formation of the principal mines producing the "gem" in Griqualand West into one gigantic enterprise is but a matter of time, and the success achieved so far by the scheme practically renders fruitless any attempt to frustrate it.

The four members returned to the Cape Parliament last week include B. I. Barnato, a diamond speculator, with a characteristic history. During his candidature, which was bitterly opposed, he related fragments of his experiences, and it is evident he has either had a special providence or has been phenomenally successful in the management of his affairs. Indeed, his history reads almost like a romance. He is a Jew, comparatively uneducated, and reached this place in 1873 with only thirty shillings as capital. He commenced at the bottom of the ladder and hawked watches on commission until he had enough to start as a diamond dealer. Three years later he had a credit balance of £3,000. His star was in the ascendant, for in 1880 he states he was making on an average £1,800 a week. To-day he is reputed worth some six millions. The fact of his being able to amass this gigantic fortune in a little more than ten years shows that he must have high intelligence to grasp all the lucky opportunities. At first his candidature was ridiculed and he received a very warm and offensive reception when he addressed the electors. They refused to hear him and he had to retire hurriedly by a back outlet. Rising to the situation, however, he addressed them in terms reminding one of the famous speech delivered by another one of his race (Disraeli) to a jeering House of Commons. Quoth Mr. Barnato: "Gentlemen, you will not listen to me now, but I tell you the

time will come when you will not only hear me but fear me." He has proved a portion of his assertion already.

This is the height of summer in Africa and the temperature is high.

"With the thermometer at 90 degrees in the shade,
And the servants in linen jackets arrayed,
One with a brush to keep off the flies,
Still the traditions of Christmas we prize:
The pudding is carved, each eats a slice,
And we think of such things as snow and ice;
And we envy our friends at home—are we silly?
The delightful sensation of feeling chilly."



[FROM OUR SPECIAL CORRESPONDENT.]

BOSTON, January 16, 1889.

The proverbial "oldest inhabitant" of this old Puritan metropolis can't remember such another extraordinarily mild winter season in all its history. Such weather as this would have been a God-send to the Pilgrim Fathers in comparison with that which met them at Plymouth Rock. The past month of exceptionally fine weather has crowded the streets with holiday shoppers. Thanksgiving and Christmas have come and gone without the slightest sign of permanent snow. Coal merchants are in despair. Stablemen must content themselves, perforce, with wheel work, while the runners rust and the sleigh bells forget their jingle in the remotest corner of the storeroom. But the jewelry trade is happy.

Christmas week showed the customary gain at all the retail stores. John A. Remick reports an unusual demand for diamonds.

The crush at Bigelow, Kennard & Co. was so great that a special officer was detailed to keep the entrance clear.

The Shreve, Crump & Low Co. are the sole agents for Boston of the Patek, Philippe & Co. watch, of Geneva.

Matthew Dolan and Bentley W. Warren have been appointed assignees of the insolvent estate of jeweler Chas. E. Davis.

A rather peculiar case was recently tried in the Superior Court, at Augusta, Me. Emerson W. Trask was indicted for embezzling \$500 worth of clocks and silverware, given him to sell on installments by the Metropolitan Manufacturing Company, of Boston. Trask claimed that he had been robbed by sub-agents, and the jury returned a verdict of not guilty. Trask at once served a warrant for extortion on N. S. Nettleton of the company. The case will come up in April.

Diamond dealers will be interested in the reported financial embarrassment of Dr. Geo. E. Lothrop, who owned the old Windsor Theatre and Boylston Museum. The former he re-modeled into the Grand Dime Museum, and the latter some three years ago was was entirely re-built and called the World's Museum. The story goes that Lothrop owes a total in New York alone of \$25,000, and that he compromised at 40 cents on a dollar. None of the other creditors has yet been asked to take less than 100 per cent., and the general idea is that the Doctor intends to pay them all in full provided he isn't crowded against the wall too hard. His diamond stock is valued at \$3,000. The worth of his museum interests is hard to figure; indeed, the cause of his embarrassment is supposed to be a too liberal investment in that sort of property. The old Windsor was always thought to be paying property, but the recent establishment next door of the Grand Opera House has probably

injured the business. The World's Museum has been sold to Wm. Austin.

I. D. Thomas, of Cambridgeport, has recovered a good deal of stolen jewelry through the efforts of Police Inspectors Ducey and Harriman.

Special officers Whittman and Conboy have recovered a large number of the diamonds stolen from the Adams Express Co. during the holidays.

Palmer, Bachelder & Co. have discharged the mortgage on their stock held by the late Oliver Ditson.

Meyer Frank, of 929 Washington street, has failed. Liabilities \$12,000; assets, \$3,000; 30 cents on the dollar is his offer.

The name of Allan Pinkerton was forged to a lease for a gold watch a short time ago by John E. Thayer, of Melrose, Mass., on the installment plan, from Alexander D. Cairns, on Washington street. Thayer said he was the famous detective's son, and manager of the Boston Branch of Pinkerton's agency on Court street. He is a gray-haired swindler, and by other similar misrepresentations has victimized other dealers extensively. He was held in \$2,000 for trial in the Superior Court.

The neighboring town of Malden has its unfortunate jeweler. Charles Crowther has been forced into insolvency and has offered 40 cents on the dollar, 10 cents in 30, 60, 90 and 120 days.

Adolph Wolff, doing business in Kneeland street, has also failed. He has sold watches hereabouts for 10 years.

Henry N. Fisher, foreman of the American Waltham Company, has been elected Mayor of Waltham for the third time successively.

The American Waltham Company's Foremen's Association met at Young's Hotel on the evening of the 5th inst. E. Hull presided. Mayor Fisher, Assistant Superintendent Shirley and Paymaster Clement discussed matters of general professional interest. Superintendent E. Fitch, R. E. Robbins, Jr., S. Avery, of the New York office, R. A. Kettell, P. W. Carter, Irving Smith, of Morrell Bros. & Co., and George H. Richards, Jr., of Boston, were present as invited guests.

LEON



ATTLEBORO, Jan. 15, 1888.

The jewelry business has been a profitable one for the manufacturers and employees the past year. It is generally considered to have been the most prosperous year which has been seen for a long time. The result of this is a feeling of content among all classes. The employers have made good profits. The employees have had continual work at good prices, thus enabling them to live well and pay their bills. All of these conditions are a great assistance to the merchants. And now that the books have been examined and a comfortable balance has been found, the manufacturers are looking ahead to see what the prospect is for the future. The year has certainly started in well. January 1 found most of the firms with plenty of orders on hand, and the depression usually expected after the holidays has not been experienced. The salesmen who are out seem to find little trouble in placing their orders, and most of the shops are being pushed.

ATTLEBORO.

There has long been a desire on the part of those people who have the interest of the town at heart, to secure for this town some new industry which would locate here and employ a large number of people. Of course, there is a great difference of opinion in

regard to what kind of a concern was most desirable. During the last few years there have frequently been rumors of some large establishment having suddenly been struck with the wonderful advantages to be derived by a location in Attleboro. It is a noticeable fact that in all such cases the principal condition under which such a location may be effected, is that the people of this town shall subscribe a good round sum of money to add to their capital stock. Just now there is considerable talk over the possibility of the Cheshire Watch Co. bringing its plant here. L. W. Sweet, the agent for the firm, is an Attleboro man, and is a brother of J. L. Sweet of the firm of R. F. Simmons & Co. This firm, which is now located in Cheshire, Connecticut, is anxious to increase its capacity, and will probably leave their present quarters at no distant date. Mr. Sweet has been in consultation with a number of the leading jewelers and he is to be here again in a few days. To get this firm here there will have to be raised not less than \$75,000, and \$47,000 of this has already been subscribed, provided the affairs of the firm will stand investigation. They now employ about 250 people, and with the addition to their capital stock this would be considerably increased. Another meeting of citizens interested will be held in a few days when it is probable that more definite action will be taken.

That beautiful smile which has been seen hovering on the face of one of our leading jewelers this week, is occasioned by the little guest which recently arrived at his house.

G. A. Dean recently purchased a large estate on North Main street.

Regnall & Bigney have taken the old stand of F. S. Draper & Co. in the Robinson building.

J. W. Bates has a lot of land well located near the railroad, which, it is said, he is willing to sacrifice if the Cheshire Watch Co. should come here.

NORTH ATTLEBORO.

North Attleboro don't propose to get left if she can help it, and now while the people of Attleboro are talking of the watch company the manufacturers of this town are talking of a brass rolling mill. But the present indications are that there is nothing in this. The fact of the matter is that there is a general opinion that the jewelers of this section are ready at all times to invest their money. Well, they are ready to invest if after a full examination they find they can do so with a chance of getting a return. The North Attleboro affair is something like this. A. J. Linton & Co. are located in Providence and run a brass rolling mill. They want more money, and if they can raise the required amount they are willing to locate here. That's the story in brief. But investigation into this firm

I had a chance a few days ago to look over the sample case of F. Mauser & Co., who deal in sterling silver novelties. It was a beauty, and it is no wonder this young firm are already having all the orders they can attend to.

H. D. Merritt & Co. are one of the firms in this town which are doing a good business. They evidently have good salesmen on the road.

Bugbee & Niles report the prospect good for the next few months.

Some of the firms closed their shops a few days the first of the month to take stock, but these have all started again. MENDON.

The Jewelers' Safety Fund Society.

THE FIFTH annual meeting of the Jewelers' Safety Fund Society was held on January 9 in the rooms of the Jewelers' Board of Trade, President Henry Hayes occupying the chair.

The report of Ira Goddard, Secretary and Treasurer, showed that the society has nearly \$4,000,000 out at risk in insurance policies, an amount a little in excess of the business for 1887. The losses sustained during the year were about \$1,000, which proves that high-waymen, the terror of old, are becoming scarce, or that travelers

have learned to be more careful of their trunks while on the road.

The dividend for 1888 has not been declared, but it will probably be in the neighborhood of the dividend for the previous year, which was about 40 per cent. The rates of insurance will remain unchanged.

By a unanimous vote the Board of Directors was re-elected without exception in the following order: Enos Richardson, of Enos Richardson & Co.; Henry Randel, of Randel, Baremore & Billings; Henry Hayes, of the Brooklyn Watch Case Company; William R. Alling, of Alling & Co.; Ira Goddard, of George W. Pratt & Co.; James C. Aikin, of Aikin, Lambert & Co.; S. C. Scott, of J. T. Scott & Co.; C. G. Alford, of C. G. Alford & Co.; F. S. Douglas, of Shafer & Douglas; S. Oppenheimer, of Oppenheimer Brothers & Veith; James P. Snow, of G. & S. Owen & Co.

At a subsequent meeting of the directors, the following officers were re-elected for the ensuing year: Henry Hayes, President; Frederick S. Douglas, Vice-President; Ira Goddard, Secretary and Treasurer. Executive Committee—Enos Richardson, Henry Randel, William R. Alling, Samuel C. Scott and S. Oppenheimer.

Business Men and College Education.



WHAT CONSTITUTES the best kind of an education for the boy who is destined for a business career, is a question that is presented to thousands of parents in its most practical form. What to do with our boys is a problem that weighs heavily upon the mind of every parent and furnishes a fruitful topic for discussion among those whose lives are devoted to educational methods. It is doubtless true that a majority of the men now engaged in active business have received their training in factories and workshops rather than in colleges, and in the fact that they have a practical knowledge of all the details of the business in which they are engaged lies the secret of their success. Education should depend mainly upon the tastes, peculiarities and ambition of the boy to be educated. If he is a student, fond of books and desirous of securing a collegiate education, he should be encouraged in his ambition; but if he has a mechanical turn of mind or shows an aptitude for general business, it is a mooted question whether or not a college education is calculated to further his success. Most parents who have themselves been deprived of the highest educational advantages are eager that their sons should enjoy them, but if the son is not a natural student it is doubtful if it is wise to insist upon his going to college. Usually a boy shows some indication of the bent of his mind by the time he is twelve years old, which is the time the question of his future begins to weigh upon the minds of those responsible for it. By that time he has received ordinarily a fair English education, and if his tastes lie in the direction of mechanics, he is of a proper age to be apprenticed to a trade or placed where he can learn the rudiments of a business education. The young man who goes to college, graduates at about twenty-five, and is then too old to learn a trade, and, if he attempts to go into business, he finds himself lacking in technical knowledge, while his juniors, with half his book knowledge, can teach him from the knowledge gained by practical experience. If he enters the employ of another, he is ashamed and frequently disheartened on finding that his college education avails him nothing, but that he must commence at the bottom of the ladder and receive only such compensation as would be given a bright but uneducated boy of fifteen. If one desires to learn watchmaking the shop is a better place for him than any college, and if he desires a business career, the place to learn it is in a business house. We by no means wish to be understood as depreciating colleges or college training, but it is a well-known fact that when college graduates go into business, what they have learned at college has to be driven out of their heads to make room for the technical knowledge that it

is necessary for them to possess in order to be successful. For the college graduate there is open the learned professions, already overcrowded, or the option of laying aside the knowledge he has so labored to obtain and substituting for it the everyday knowledge that will win him his bread and butter. It is getting to be very generally conceded that the boy who is destined for a mechanical or business career should be allowed to begin it as soon as he has become sufficiently familiar with the rudiments of an education to enable him to apply himself intelligently. American boys are usually sufficiently advanced in their studies by the time they are twelve or fifteen years of age to be placed in that business or calling to which they expect to devote their lives.

There are, however, too many parents who do not appreciate the importance of placing their sons where they will learn one branch of trade or business, learning that well so as to command confidence and satisfactory remuneration. Hence we see thousands of boys throwing away the best years of their lives running errands as messenger boys, serving in telegraph offices, doing chores around saloons and restaurants, but not learning anything that will be of value to them when they reach man's estate. From these boys, knowing no useful calling, too large to serve as errand boys, come our criminal classes. The "gangs" that hang around street corners, smoking, drinking, stealing, filling the jails and penitentiaries, are recruited from the hosts of boys whose parents fail to teach them a trade or any legitimate business. When boys run the streets, whether employed as errand boys or not, they very soon pass from under the control of their parents, and an idle if not a vicious life is the result. We believe most thoroughly in the early industrial training of boys, and would gladly welcome the return of the apprenticeship system, that has fallen into disuse during the past few years to so great an extent. We also favor the highest education possible for those whose tastes run in that direction, but as the majority of men must always be devoted to active business pursuits and the professions limited to a comparatively few, the education of a majority of boys should be in the direction of business pursuits, and that this cannot commence too early is our conviction.

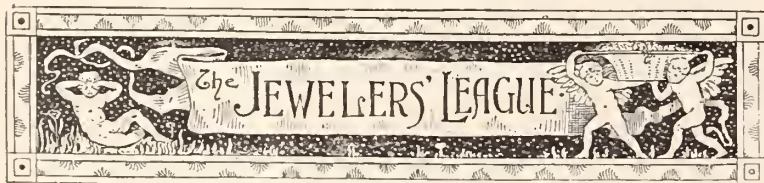

President, HENRY HAYES.....Of The Brooklyn Watch Case Co.
First Vice-President, JOSEPH E. BOWDENOf J. B. Bowden & Co.
Second Vice-President, CHARLES G. LEWISOf Randel, Baremore & Billings.
Third Vice-President, JAMES P. SNOWOf G. & S. Owen & Co.
Fourth Vice-President, ROBERT A. JOHNSON.....Of Celluloid Enamel Co
Secretary and Treasurer, WILLIAM L. SEXTON.....Of Sexton Bros. & Washburn.

EXECUTIVE COMMITTEE.

GEO. H. HOUGHTON.....With Gorham Mfg. Co.
 WM. H. JENKS.....With Tiffany & Co.
 A. A. JEANNOT.....Of Jeannot & Sheibler.
 GEORGE R. HOWE.....Of Carter, Sloan & Co.
 WM. BARDEL.....Of Heller & Bardel.
 J. R. GREASON.....Of J. R. Greason & Co.

At the regular meeting of the Executive Committee of the Jewelers' League, there were present President Henry Hayes, Vice-Presidents Snow, Lewis and Johnson, and Messrs. Greason, Jeannot, Bardel Houghton, Howe and Sexton.

Messrs. Bardel, Greason and Jeannot were appointed a Reception Committee for the Annual Meeting, which is to be held on Tuesday evening, January 15, at Masonic Hall.

There were two changes of beneficiaries granted.

Two applications were referred for investigation.

The following applicants were admitted to membership:

Geo. E. Fahys, Brooklyn, N. Y., recommended by Henry Hayes;

Chas. L. Kittlety, Providence, R. I., recommended by I. N. Bailey; Maxwell G. Mains, Billings, Montana Territory, recommended by C. G. Alford; John Pfister, St. Paul, Minn., recommended by C. E. Grow; Everett I. Rogers, Brooklyn, N. Y., recommended by Geo. W. Parks and Fred. N. Miller.



Annual Banquet of the Chicago Jewelers' Association.

[FROM OUR SPECIAL CORRESPONDENT.]

CHICAGO, Jan. 1, 1888.

That Chicago jewelers occupy a high position in the public esteem has been again proven. Great financiers, eminent jurists and eloquent preachers eagerly accepted the invitation for the annual banquet of the Chicago Jewelers' Association, and the daily press has devoted columns to the recounting of flights of oratory and feats of gastronomy.

From New Year's Day until the eventful evening of the 8th, Messrs. Peck, Sercomb and Flershem let the every-day affairs of this mundane existence take care of themselves. To suggestions for the greater success of the banquet they each lent willing ears, but the sale of clocks, jewelry and silverware was much too prosaic to engage their attention. The success of the feast was due, in great measure to the solid week's work done by this trio of prosperous and popular good fellows.

A toothsome menu held all the greater promise of good things to come, by reason of being hand-painted on cards of celluloid, which evidenced that good taste which all jewelers must in greater or less degree possess. The members of the Association who braved the wind and rain to add their presence for the general good were these: A. E. Bentley, George G. Gubbins, Sigmund Stein, Max Ellbogen, Abram Hart, H. F. Hahn, F. M. Sproehnle, A. W. Sproehnle, Otto Oppenheimer, Thomas Evans, Wm. F. Juergens, Wm. C. Andersen, J. A. Todd, H. S. Peck, W. M. Alister, W. N. Burchard, O. W. Wallis, Benjamin Allen, C. K. Giles, J. V. Ridgway, J. F. Talbot, J. L. Lake, George Weidig, A. L. Sercomb, J. W. Meacham, Francis E. Morse, John F. Morse, W. T. Tompkins, G. W. Church, John M. Cutter, William George Prall, H. M. Carl, C. H. Knights, W. H. Gleason, Peter Lapp, L. W. Flershem, Grove Sackett, T. H. Purple, M. A. Mead, Otto Young, Julius Schnering.

The guests included Mayor Roche, Bishop Cheney, Judge Gary, famed as the foe of Anarchy, and about a hundred of Chicago's worthiest citizens. A mandolin orchestra discussed its music until nearly 10 o'clock, with knife and fork accompaniment and liquid variations from tinkling glasses and popping corks; then came the feast of reason. President Peck arose and, responding to the first toast, "Breaking through the chills of ceremony and selfishness, and thawing every heart into a glow," said:—

"I trust that no formal words of welcome are necessary or expected to assure you each and all of our gratification at your presence here to-night; if so, I do not feel qualified to express them in such a manner as would convey their full meaning.

Our annual banquet, coming as it does at the close of the season of great activity, so peculiar to people engaged in our special lines of trade, and also coincident with the holidays, when all hearts are supposed to be susceptible to feelings of gladness and good cheer, seems to be an appropriate time for us to invite our friends to meet and rejoice with us. I only wish our banquet hall was as large as our fraternal feeling, so that we might include all who are engaged in the jewelry trade.

As an Association, the past has been one of great significance and encourage-

ment. The marked increase in our membership, as well as the unusual activity and increased business of each department connected with it, has infused new life into the Association and its members. It has opened new channels of usefulness, which were not contemplated by its founders, and even now the limit to which it can render valuable assistance in extending the interest of members and incidentally add to the importance of Chicago as a business center seems far in the distance. I believe the time is approaching when the value of these independent trade associations will become more thoroughly understood and appreciated, and eventually each distinct branch of commerce will obtain, in a great measure, the information so necessary in making credits through channels of its own.

Within the past year our sister Association of New York, the 'Jewellers' Board of Trade,' decided, by the action of its directors, to co-operate with us, to some extent, and thus add to the usefulness of both. The beneficial effects of this combination have already been demonstrated and recognized as important factors, and to our friends in the East we extend all the congratulations of this happy season.

I do not suppose we could be considered as a genuine Chicago institution if as an Association we did not claim our full share of the honor in helping to place it in its present position of high renown, and demand recognition as an important business factor in increasing its commerce, thereby adding to its reputation as one of the leading and distributing cities of the country.

While our modesty may prevent our making these claims in an ostentatious manner, we still insist upon them, and know that the records of the Association itself as well as that of its individual members, warrant us in doing so, and we feel that they are acknowledged by leading institutions in other lines that are brought into business connections with us.

It is a matter of congratulation that the reports from dealers point to a year of success and steady business improvement. It seems to be an accepted fact by manufacturers, as well as jobbers and retailers, that permanent business prosperity can only be attained by judicious catering to the public demands, and not expecting any remarkable increase of business beyond that warranted by the uniform prosperity and growth of the Nation at large.

The jewelry business, like other branches of trade, and more than some, is affected by any disturbance in the financial world, and we have every reason to hope the present healthy condition of values may continue.

I now suggest that we cast the dull care and anxieties of the past behind us, and for this evening all enter the full enjoyment of the present and the bright anticipations of the future; at this table there is no room for trouble, except for the waiters."

The cigar smoke increased, as did the noise of popping corks and laughter, until, in the "wee, sma' hours," the last toast was ended and Gen. Stiles had impressed on the minds of the jewelers:—

"Expect no credit for too wondrous tales,
Since Jonahs only spring alive from whales."

The twelfth annual banquet will not be forgotten until its memory is washed away in the wines of the thirteenth.

The employés of C. H. Knights & Co. recently had a banquet all to themselves. It was tendered them by the firm, and included no outsiders except the wives of about a dozen of the benedicts. Kinsley's was the place chosen for this dinner also, and music and toasts enlivened the evening. Given on December 28th, it fittingly closed a prosperous year for this popular establishment. Among those present were:—Messrs. and Mesdames C. H. Knights, W. H. Gleason, F. G. Thearle, Jr., W. E. Shandrew, O. C. Jaquith, R. W. Barlow, C. A. Garlick, E. A. Thearle, C. W. Hayden, John E. Wood, G. Pfister, Messrs. W. H. Johnson, T. J. Bristol, C. P. Smith, S. H. Scaggs, R. D. Lewis, John Brayton, E. S. Cheney, A. W. Johansen, William Schlossman, Edward Walters, E. A. Dorrance, Edward Jamison, Will Baltcher, A. Ross, Fred. Allen and Miss Fannie Shiraek.

Mr. C. H. Knights, who is in New York attending the meeting of the National Association of Jobbers, will find on his return that his January trade is equal in volume to that of a year ago, despite the fact that what is known as the "pineries" trade, which usually cuts quite a figure in this month, has been delayed by reason of no snow in the woods of Northern Wisconsin and Michigan.

F. Ternendt & Bro., manufacturing jewelers at 57 Washington street, dissolved partnership on the 16th. F. Ternendt continues the business, and C. Ternendt intends joining his father-in-law, Francis Ebener, in the retail jewelry business, already established on North Larrabee street.

The failure of G. H. Loehr, at 78 State street, has attracted so much comment from jewelers here that your observer has endeavored

to gather all the information possible concerning it. Chas. F. Wood, who loaned money, seems to be the only creditor who has realized anything, and the claims of the others can be purchased at a discount of about 99 per cent. At the chattel mortgage sale, the outfit was sold to Riehm & Beygeh, who will use one half of Loehr's former premises in manufacturing jewelry.

Loehr has announced that he would open a "diamond importing business" on the fourth floor of the same building, and a card on the door of a room on that floor bears his name, but Mr. Loehr himself could not be found. Your observer asked the elevator boy when he had last been seen, only to learn that it had not been for some days when he (the boy) had loaned him all his pocket money. Loehr is a Loyal Knight Templar, and this fact has shielded him to quite an extent from the punishment, which pawning goods obtained "on memorandum" would seem to merit.

W. W. Davey, of Ripon, Wisconsin, was the last of Loehr's victims seen by your observer. He is here anxiously searching for both Loehr and a pair of 4 carat diamond solitaires sent him on December 15th to be re-set. The most charitable explanation of Loehr's misdeeds would seem to be that, being hard pressed by his creditors, he was trying to worry through until after the holidays, hoping then to be able to redeem and return the goods entrusted to him.

The Loverin Wholesale Grocery Company, of this city, are adding jewelry to their stock, samples of which are to be carried by their regular travellers.

The annual meeting of the American Spring Company, of Oak Park, Illinois, resulted in the election of the following officers and directors:—John H. Purdy, President; W. H. Wood, Vice-President; Fred. H. Word, Secretary and Treasurer; Directors: John H. Purdy, W. H. Wood, Frederick Sedgwick, F. L. Stevens, and John D. Caldwell. This company are the only manufacturers of watch springs by electricity under the Sedgwick patents.

The Chicago Horological Institute having found the premises at 182 State street inadequate to their purpose, have just completed the fitting-up of their rooms at 175 Dearborn street. Urban W. Frink, of the jewelry house of Joseph & Fish, is the president, and O. C. Jaquith, who has charge of the watch tool department of C. H. Knights & Co., is the secretary and treasurer. While the purpose of this institution is not so much to build up a large attendance as to give a less number a thorough watchmaking education, scholars are matriculating from all parts of the country, and the seating capacity of the school will soon be taxed to its utmost. The Moseley lathes now in use will be supplemented with several Whitcomb lathes made by the American Watch Tool Company. The charge to students, including use of lathes, counter shafts, foot wheels and benches with drawers, is \$75 per quarter.

Frequent observations made during the month indicate that the New Year is opening auspiciously. The entire jewelry trade report this month's business as fully equalling that of a year ago, and, in many cases, a marked increase is noted. The Gorham Manufacturing Company are as busy this month as they were in December, which is remarkable.

The trade in general report larger sales in 1888 than in previous years, but at closer margins of profit, making the net result almost the same as in 1887. All report that out of town merchants are paying more promptly than usual.

Eastern factories have had their salesmen here since December 15th, and, in addition to securing the orders of Chicago buyers, they occasionally get the drop on merchants from points further West. Mr. Ayres, of Keokuk, was observed making purchases of an Eastern drummer last week. However, there have not been half a dozen prominent out of town jewelers in this market for a month, and our wholesale jewelers would be better pleased if the irrepressible traveling salesmen had deferred their visitation until opportunity had been had to figure up last year's account before re-loading for the coming campaign.

C. K. Giles lectured in Davenport, Iowa, the other day on "Mag-

netism in Watches." Mr. Giles speaks on this subject with undisputed authority, and his firm report a greatly-increased demand for their magnetic shields in 1888 over any previous year.

Stein & Ellbogen, wholesale jewelers of this city, announce their purpose of retiring from business, and have issued a circular asking their debtors to settle their accounts promptly. The partners have been associated together for the past twelve years, and each traveled four years, alternating, for the same house before embarking for themselves. They have been and are warm personal friends, and both are highly esteemed by the trade. Both Messrs. Stein & Ellbogen were born on the same day of the same year, and so greatly resembled each other as to constantly bewilder their acquaintances. In connection with Mr. Stein, a day or two since, your observer learned sufficient to warrant THE JEWELERS' CIRCULAR in prophesying, despite the announcement made by the firm that Messrs. Stein & Ellbogen will not long remain out of the business they have so long honored, and that as soon as they have paid their creditors dollar for dollar, as they undoubtedly will, and have collected the large amount of outstandings due them, they will continue their popular and prosperous career.

THE CIRCULAR'S OBSERVER.

Deposition of Gold by Simple Immersion.



AQUEOUS solutions of gold deposit their metal upon surfaces of phosphorous, silver, mercury, copper and nearly all the base and brittle metals, by simple contact with those substances. According to Commaillé magnesium deposits pure gold from an aqueous solution of the terchloride. I have observed that crystals of silicon did not deposit gold from a solution of its terchloride, but that by contact of the terchloride in aqueous solution with benzine, petroleum, ether, amylene, and a number of other liquid hydro-carbons, films of metallic gold gradually separated.

For gilding articles of copper, bronze or brass, by simple immersion, the following solution of Roseleur's may be used: Dissolve 800 parts by weight of pyrophosphate of soda in 10,000 parts of distilled water and add 8 parts of strong hydrocyanic acid. Convert ten parts by weight of gold into soluble dry chloride, dissolve it in a reserved portion of the water to which nothing has yet been added, and mix the resulting liquid with the cold solution of pyrophosphate. The mixture is used hot; it is yellowish, but must become colorless when heated; if it becomes red, a little prussic acid must be added, with stirring, until the liquid is colorless. If too much of the acid is added it will prevent the articles becoming gilded, and this may be corrected by adding a small quantity of chloride of gold solution. The articles to be gilded must be previously dipped in a very dilute solution of nitrate of mercury; and while being gilded they must be kept in continual motion. To gild most successfully by this process the articles should receive a first coating of gold in a nearly exhausted solution of the same kind, a second in a less exhausted one, and a third in a more freshly prepared one to impart a proper color. The gilding occupies only a few seconds in each bath. To obtain "green" and "white" gilding in such a liquid, a solution of nitrate of silver is added, drop by drop, with stirring, until the desired color is obtained; before gilding green or white it is best to gild the articles yellow, then dip them quickly in the nitrate of mercury solution, and then into the bath containing the nitrate of silver.

Gilding by simple immersion is also employed for putting an exceedingly thin deposit of gold upon large articles of bronze previous to proper gilding; then with a thicker deposit in a cyanide solution by the battery process. The solution employed is composed of 180 parts of caustic potash, 20 parts of carbonate of potash and

9 parts of cyanide of potassium dissolved in 1,000 parts by weight of water, in which has been previously dissolved as much chloride of gold as is formed from one part by weight of the metal. The mixture is used nearly at a boiling temperature. The articles to be gilded do not require to be previously dipped in a mercurial solution. As the solution loses its gold chloride of gold must be added, but after four or five such additions the other salts must also be added with it in the above proportions. The solution may thus be kept in order for any length of time.

It is possible to gild copper and brass articles perfectly by simple immersion by employing the artifice of "quicking" the surface before each immersion, by dipping it alternately into a solution of nitrate of mercury and into the gilding liquid; and this plan is often adopted with large articles. It is said the copper may be gilded so perfectly by this method as to resist for several hours the corrosive action of concentrated acids. The secret of the action is that each film of mercury, being electro-positive to the gold, dissolves in the auriferous solution and deposits a film of gold in its place.

A solution for gilding by simple immersion was at one time extensively used by Messrs. Elkington. It was prepared as follows: Convert one part of gold into terchloride and expel all excess of acid; dissolve it in a small amount of water, and add gradually to it thirty-one parts of acid carbonate of potassium; then mix the liquid with a solution of thirty parts more of the acid carbonate dissolved in 200 parts of water and boil the mixture for 2 hours. During the boiling the yellow solution becomes green, and it is then ready for use. The previously cleared trinkets of brass or copper are immersed for about half a minute in the hot liquid. To gild articles of German silver or platinum in this bath, they must be immersed in contact with wires of copper or of zinc. Chlorate of potash is formed in the solution by the gilding process and a black powder is precipitated, containing carbonate of copper and a little purple of Cassius.

The two following liquids have also been used for gilding by the simple immersion or water-gilding process. Convert five Troy ounces of gold into chloride, dissolve it in four gallons of distilled water, add twenty pounds of pure bi-carbonate of potassium, and boil it during two hours. The articles to be gilded are immersed in the warm liquid from a few seconds to one minute, according to the degree of quickness of the action. For gilding articles of silver: Dissolve equal weights of corrosive sublimate and sal ammoniac in nitric acid, add some pure grain gold to it, evaporate the liquid to half its bulk, and apply it whilst hot to the surface of the silver article.

C. D. Braun gilds zinc by immersing it in a solution of sulphide of gold dissolved in a solution of sulphide of ammonium excluded from the atmosphere. W. Kirchmann gilds clean iron by first applying to it sodium amalgam, which coats with mercury. He then applies to the mercurialized surface a strong solution of chloride of gold, and finally heats the object to redness in a muffle.

DISCOVERERS OF ELECTRICITY.—Beside Otto von Guericke, who constructed the first electric machine, Benjamin Franklin of well known celebrity, also Hauksbej, Gray, Du Fay and George Matthias Bose, Professor of Physics in Wittenberg, contributed largely to develop the science of frictional electricity. The latter, in 1744, expressed his complaints in poetry as follows:

I can make the spark to appear,
It catches, lightens, thunders, ignites a thousand times,
But I cannot cook with it."

May he compose his soul in peace. We, his descendants, 144 years after him, are not yet able to do it.

Fashions in Jewelry

A Lady's Rambles Among the Jewelers.

THE past twelve months have brought about a number of important changes, the effects of which are more or less beneficial to the jewelers' trade. The freedom with which jewelry is now worn abroad by both sexes, and the incoming of the Directoire toilettes which demand jewelry as a necessary accessory, are notable illustrations.

* * * * *

A CHANGE has been wrought in English taste in jewelry, and this change reflects, in a manner, here. In way of personal adornment there have hitherto, generally speaking, been only two classes, the formal and the realistic. Persons who grew weary of bars, squares and balls, had no option but to adopt still more unmeaning ornaments as tennis rackets, croquet mallets, horseshoes and the like. There is now, happily, a tendency to discover the medium between these two extremes, and the result has been many ornaments of great artistic merit and ingenuity.

* * * * *

TO THE English we owe in part, at least, the present popularity of watches. The revival of chatelaine watches along with Empire and Directoire gowns, began in London, and the fad for placing tiny dials in all sorts of odd places may be said to have originated with the clumsy English leather watch wristlets.

* * * * *

SPEAKING of watches, there has been quite a run on the new Directoire chatelaine form. These timepieces may be either in gold or silver. Some of the latter are beautifully chased, while others are enameled or set with colored stones.

* * * * *

QUITE fashionable for chatelaine purposes are the pretty crystal ball watches, some of which keep very true time.

* * * * *

TINY dials with colored numerals and gold hands, set in one corner of a card case, in the tortoise shell stick of a fan, in the handle of a Directoire umbrella, or in the center of one's purse, are now familiar objects to everybody who has access to the show cases of jewelers who enjoy a fashionable patronage.

* * * * *

THE most popular watch bracelet is the one known to the trade as "screw" bracelet, which holds an ordinary watch without increasing the size by an extra case.

* * * * *

THE Louis Quinze style is likely to revive the bygone taste for ormolu, and clocks have already been produced in exact reproduction of this style. One seen had the dial, which was of white china, attractively painted, and surrounded with a circle of paste brilliants.

* * * * *

NOVELTIES in the way of clocks include paper weights with a clock

set in the center; then there are combination affairs, in which appear a clock, a thermometer, an inkstand, etc., in instance of which may be mentioned the "Tennis" ink set. This, as the name indicates, consists of a racquet containing a clock and thermometer, and forming a paper clip. The tennis ball, on being opened, discloses a porcelain ink stand.

* * * * *

THE very newest thing out that employs miniature clocks is the new carriage basket in cloth to match the lining of the carriage, and containing a mirror, memorandum slate, pocket for cards, pin cushion and a trustworthy clock, the last named being placed outside in the center of the basket.

* * * * *

THE Queen chain is a convenient receptacle for all sorts of unique charms. A recent addition to the list is a nickel holder in the form of a locket.

* * * * *

LOCKETS, by the way, are worn on watch chains by both men and women. These trinkets run small to medium in size, and are often set with small stones.

* * * * *

FOR mourning, there are ebony balls studded with pearls, and filigree balls in black enamel set with diamonds.

* * * * *

"LOVE and luck" jewelry, as hearts, darts, doves, horseshoes and "merry thought" bones are termed, find a generous patronage among the superstitious and love-lorn men and maidens. A favored design is one of the several combinations of a true lover's knot and horseshoe, or the knot and heart. These patterns are made in gold and silver, and gold and platinum, and often are set with brilliants. There are "love and luck" bracelets, brooches, scarf pins, sleeve buttons, bonnet pins and finger rings.

* * * * *

AN ATTRACTIVE brooch consists of two gold wishbones interlocked, the space in the center being filled with a branch of holly in enamel, upon which sits a jeweled robin.

* * * * *

DIAMOND brooches of recent manufacture simulate in form a branch of holly with clusters of berries.

* * * * *

IMPELLED by the success of the "1888" jewelry, manufacturers have placed on the market, in limited quantities, "1889" jewelry. This consists of gold or silver wire ingeniously twisted and knotted so as to show in the windings the figures 1889. This jewelry includes bracelets, brooches and scarf pins.

* * * * *

NUMBERED with artistic brooches are historical and ideal heads painted on ivory, and set in a framework of diamonds or pearls.

* * * * *

EAR RINGS simulating flowers are much worn by our misses and young ladies. The ball ear ring continues a favorite, and is equally

fashionable when of Roman gold finish, carved, enameled or studded with little gems.



INEXPENSIVE brooches are silver ones in shape of ribbon bow-knots or of twisted wire or cord tied in true-lover's knots; also chain links curved into square and round shapes

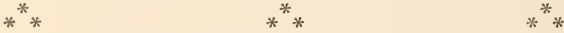

ENAMELED jewelry is still worn, and is most popular, perhaps, in form of flower brooches and bonnet pins.



A UNIQUE brooch consists of a pearl-set ring enclosing a pearl trefoil. Another remarkable brooch simulates two diamond trefoils, about the stems of which coils a pearl snake.



A PLEASING bar brooch shows a short gold bar terminating at either end with a pearl and interlacing two brilliant circles. This same design is carried out with horseshoes instead of circles.

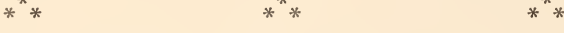

A PRETTY gold brooch is the one that copies the outline of a rose and a clover leaf, held together with a ribbon.



BONNET pins are larger in size than formerly, and are, many of them, in floral pattern, though the fly pins continue popular. There is also more or less demand for bird pins. Swallows and robins are in request.



APROPOS of bird pins, is the brooch christened "Just Out," and representing in gold and enamel a newly-hatched chick surveying a broken egg shell.



FINGER rings for both sexes are on the high wave of popularity, and there is a widely diversified variety of patterns from which to select. Colored stones set among diamonds or pearls are conspicuous in these rings. Colored precious gems are in great favor, such as brown, canary and pink diamonds, pink, gray and black pearls, sapphires, opals, rubies and fine garnets.



THE Marquise ring, either all brilliants or with ruby or sapphire center, continue to win favor. Fine turquoises of oblong shape are effectively mounted in Marquise rings when surrounded by small diamonds.



THE three-row ring, a comparatively new pattern, has met with a flattering reception. As the name indicates, this ornament consists of three gold wires, one set with a ruby and two diamonds, another with a sapphire and two diamonds, and the remaining one with a pearl and two diamonds.



THE old-time double heart ring has been revived. One seen

recently was set to represent two hearts—one thickly set with pearls and the other with rubies, and united with a true-lover's knot.



FASHIONABLE finger rings are of colored stones framed with diamonds, the cluster forming round or square shapes, or a long Marquise medallion, or else diagonal lines or a straight row around the finger.



CLUSTER rings remain fashionable. A unique ring consists of two small clusters set with pearls and diamonds, and having ruby and sapphire centers.



FOR quite young ladies there are finger rings of blue enamel set with pearls; also rings set with turquoises and pearls. Turquoise remains a favorite stone for children's rings.



THERE appears no diminution in the demand for gold and silver rings in knotted patterns. An attractive ring of this kind consists of four gold or silver wires tied in a double knot on top.



NUMBERED with fanciful devices in ladies' rings are those showing a crescent of tiny diamonds, inside of which appears a carved moonstone of fine quality or a cat's-eye.



FINGER rings set with single gems of large size and fine quality, it need hardly be told, remain in fashion, and are the ambition of every lady who can afford to possess the same. The setting to these solitaire rings remains unobtrusive.



SIGNET rings of the antique mould are in favor for men's wear. The stone in these rings is, as a rule, decorated with an initial, a monogram, a crest or a coat of arms.

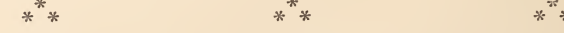

THE snake ring, in gold or silver, and set with one fine stone, is now popular. Another favorite ring among men is the gold band, square in design, with a diamond set flush in the center and a colored stone on either side of the diamond. Sapphires, rubies and fine cat's-eyes are preferred gems for men's rings.



STUDS are generally worn with evening dress. Elderly men, and, indeed, others if they choose, may wear the white enameled ones. Small but fine diamonds are fashionable in studs; so are pearls. Black pearls, when fine, are highly esteemed among men, not only when set singly in studs, but mounted on scarf pins.



A RAM's head with ruby eyes, is a favorite device for scarf pins as well as for men's finger rings.



SMALL brilliants are used with good effect on some of the more realistic scarf pins, such as a fox head in small diamonds or a bril-

liant hound. For the stock exchange there are diamond bulls and bears, while horsemen can revel in scarf pins that simulate a horse-shoe, a crop, two spurs interlocked, a jockey cap or a whip.



NEW English scarf pins include what are known as the rose, shamrock and thistle pins, each formed of brilliants. These same floral models serve as bonnet pins for the ladies.



FOR men who revel in oddities are all kinds of fantastic scarf pins, such as the Bluebeard pin in enamel and diamonds, the Judy pin in enamel and gold, Punch in enamel and diamonds, and Othello pin carved onyx and diamonds. A whimsical pin, which nevertheless finds patrons, is one that simulates the human hand, in gold, holding a "straight flush," the cards being enameled in colors.



THE strenuous efforts made both abroad and at home to push ear rings have been attended with fair results. While it cannot be said with truth that ear rings are as popular as brooches and bracelets, for instance, it is affirmed without fear of contradiction that these ornaments are again fashionable.



LADIES in polite society no longer restrict themselves to solitaire ear rings, but for morning and other *negligé* occasions wear gold ball, tiny enameled and other unobtrusive styles of ear rings.



IN FRANCE ear rings are again permissible to young ladies, and, of late, the tendency has been towards a revival of the long pendant ear rings.



FANCIFUL patterns are on the increase. Little gold wire baskets enclosing an opal or other gem, are pretty devices, as are tiny gold bells with a pearl for a clapper.



DECORATIVE hair pins and combs have attained a widespread popularity, and consequently are made in many and diversified designs. These pins, in one form or another, are within the reach of all, being made in tortoise shell, amber, silver and gold.



HAIR pins which are most widely known are those that take on such forms as a boat hook, an interrogation mark, a shepherd's crook, an arrow, and an ordinary pin surrounded by a big round ball, a knot, a crescent or a horseshoe.



IN ADDITION to the decorative hair pins are many costly ornaments for the coiffure, such as sprays and *rivieres* of diamonds, enameled roses growing out from gold stems, and apple blossoms with diamond dew drops.



SILVERSMITHS have succeeded in reviving the demand for silver ornamentations in various directions. Silver is not only more exten-

sively employed for dinner and tea ware than formerly, but such things as frames of boxes and mirrors, borders of toilet tables, caskets, small clocks, calendar frames and the like, are now of this precious metal.



SILVER photograph frames continue the rage, and ladies who are ambitious in this direction have made some wonderful collections as regards variety of styles and finish. Numbered with novel frames is one in fluted silver, with a watch movement in one corner.



FRAMES of *repoussé* silver are on calendars for 1889; thermometers are also set in silver.



THE jeweled combs of amber and shell, so often described, continue to find a place in fashionable hair dressing.



AN EXCEEDINGLY effective hair ornament is a diamond butterfly or star, that quivers with every motion of the wearer, being set on a spiral spring.



THE smoker's paraphernalia presents a variety of forms. The square silver tray, with four square shaped receptacles, graduated in size for matches, cigarettes, cigars and tobacco, is a favorite.

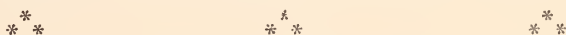

THERE are oblong boxes in silver plate, fitted with trustworthily locks, for both cigarettes and tobacco. The lid plain or ruled with horizontal grooves has two shields; on one is engraved the monogram of the owner, and the other proclaims the nature of the contents.



CASKETS are now made in copper in exact semblance of a real cigar box. The copper is finished so as to imitate the grains of the cedar, and the silver the labels, with the usual Spanish formulas upon them.



SILVER cigar and cigarette cases seem to have the preference over other kinds. Decided novelties in this line are silver boxes, on the outside of which appear beautifully modeled figures in silver and in gold. A handsome cigar box seen recently was of ebony, with a nicely chased silver top on which were modeled figures in silver.



MATCH boxes are not only made *en suite*, but come in a multitude of fancy shapes, among which may be mentioned a short stick of sealing wax, a half burned cigar, an anvil. There are also oblong match boxes in silver, the top of which is in white enamel, to simulate a visiting card, and on this the name and address is engraved.



THE paper weight, as devolved from the silversmith's hands, is frequently a vehicle for holding wax tapers, with an inkstand on tray. An instance in which all three are included, is a broken egg shell in

silver reposing by the side of a gilt truss of straw, presided over by a chanticler in bronze.

* * * * *

INKSTANDS are concealed within terrestrial globes and in the heart of cabbages. A polished horse's hoof, mounted in silver, makes an admirable holder for ink, and four hoofs combined and mounted with spurs, stirrup and bit, a monumental inkstand for its title.

* * * * *

IN THIS connection may be mentioned a curious smoking table in metal that represents a mammoth horse's hoof supported by three whips. The whip handles form a tripod upon which rests the nicked shoe.

* * * * *

TO RETURN to furnishings for the writing desk, mention is made of a combination stand for cards, telegrams, engagement tablets and letters. These stands are of leather with handsome silver mounts.

* * * * *

A NEW postage damper and paper weight combined consists of a rock crystal ball, with silver lid and brush-holder handle.

* * * * *

SEALS continue to be used by fashionable folk, and some of them are both artistic and expensive, oxidized silver, bronze, gold and onyx being employed for the handles to the seals. The seal is cut, as best suits the taste of the owner, with a monogram, coat-of-arms, a motto or a device; the monogram takes the lead. A fancy indulged in by some ladies is using a seal engraved with a favorite flower, and when the owners answer to such botanical names as Rose, Violet, Lily, etc., the flower selected for the seal is suggested by the lady's name.

* * * * *

PIN cushions with silver trimmings are on every lady's toilet table, and most men own at least one that is carried in the pocket. There are acorn cushions, the acorn being of plush or satin, in a silver stalk with oxidized oak leaves. A decided novelty is a swan in silver with a pin cushion between its wings and on its back. Cushions attracting attention are those with modeled figures in silver, as a bust of a gypsy or a shepherdess, mounted on an inflated skirt of plush or satin, which serves as a cushion. Heart-shaped pin cushions, with a silver cover, which latter, on being inverted, becomes a jewel tray, are pretty novelties in this line.

ELSIE BEF.

Annual Report of the Manufacturing Jewelers' Board of Trade, of Providence.

PROVIDENCE, R. I., December 29, 1888.

To the Officers and Members of the Manufacturing Jewelers' Board of Trade:

GENTLEMEN—I have the honor to present herewith for your consideration the annual report of the transactions of this office.

By the change made in the by-laws, the time for holding the quarterly meetings was made to conform to the current quarters of the year, and that of the annual meeting to the last Saturday in December, thereby closing the business with the calendar year instead of carrying it over into another year; hence this report covers a period of only eleven months.

The Board of Trade has held but two quarterly meetings, the one of June 30 being adjourned for want of a quorum.

Two creditors' meetings have also been called, both in the interest of the affairs of J. M. Chandler & Co.

On the 4th day of February the Directors chosen at the annual meeting met and organized as follows: Dutee Wilcox, President; Fred. I. Marcy and Joseph L. Sweet, Vice-Presidents; Hoffman S. Dorchester, Treasurer; Marcus W. Morton,

Secretary; Everett S. Horton, Ralph S. Hamilton, Jr., and Nathan B. Barton, Finance Committee.

The Board of Directors has held twenty-four meetings during the year, eleven being regular, two adjourned and eleven special. The business of the year has required much time and consideration at the hands of members of the Board, which has been cheerfully and promptly given with the intent that the greatest good accrue to the greatest number and the organization be thereby necessarily strengthened.

FAILURES.

During the year there has occurred sixteen failures, in which the members of the Board of Trade have been interested to the amount of \$65,095.22 as against \$155,860.71 of the preceding year.

Five of these cases, representing an indebtedness of \$41,972.06, have been compromised upon a basis of from 20 to 50 per cent., or an average of 37½ per cent.

COLLECTIONS.

The Collection Department shows the following:

Number of claims received 143, amounting to \$22,477.80.

Number of claims collected in full,	73	} Amount,	\$9,949 93
“ “ “ part,	6		
“ “ withdrawn,	5	“	1,576 81
“ “ uncollectable,	17	“	2,006 89
“ “ pending,	25	“	2,920 21
“ “ reduced to judgment,	12	“	6,023 96
	143		\$22,477 80

REPORTS.

During the year 1,549 inquiries have been received and answered, 513 regularly numbered, and 307 incidental reports have been issued.

MEMBERSHIP.

The present membership is 106.

Number of members last annual report,	-	-	-	113
“ new members admitted,	-	-	-	4
“ reinstated,	-	-	-	2
Total	-	-	-	119
From which deduct, resigned 8, out of business 3, dropped 1, expelled 1,	-	-	-	13
Present membership,	-	-	-	106

Taken in its entirety, the work of the year compares favorably with any of the preceding ones. In some directions very much more has been accomplished. As we all come to know and understand the true theory of the principles of our organization and practically apply them, it is then we realize its strength and see successfully carried out its objects.

A single illustration will suffice—the case of J. M. Chandler & Co. Perhaps none of recent date has presented itself where so much personal time and attention has been required and given. The presence of Mr. Chandler here, early in October, where he met a large number of his eastern creditors, and who, after hearing his statement, unanimously granted his request for an extension. Within two weeks, however, came the announcement of his suspension, with liabilities approximating nearly \$70,000.

In accordance with our rules, a committee from the Board of Directors proceeded at once to investigate the case, and for this purpose went to Cleveland, where a personal examination of stock, accounts and court records was made, thereby becoming thoroughly acquainted with all details of the situation. This resulted in a conference with the New York Jewelers' Board of Trade, where a similar committee was appointed and articles of agreement duly executed, authorizing and empowering the attorneys representing the two Boards to file a petition for the removal of the assignee and appointment of a trustee to close up the business. This was carried out, the trustee chosen who is now in process of the execution of his trust, thus showing that by prompt, personal and combined action much more might accrue to creditors than to allow debtors to offer what they may elect, and we accept that or nothing.

There should be no hesitancy, it seems to me, in this particular; be the case one involving hundreds as well as thousands, the emergency exists and should be promptly met and our interests carefully looked after. Not allow stock to be sold to A, B and C, relatives and friends of insolvent debtors, for a mere song, to be again reconveyed when the troubled waters again assume their wonted calmness, but be on hand with a committee acquainted with the value of the stock prepared to act, that the most may be realized for creditors, even if need be to the purchasing of the stock rather than see it sacrificed.

In three of the settled cases before mentioned, offers of settlement were made and declined because of the knowledge of facts in possession of the committees that the estates could make a better offer, which subsequently was done. In that of J. M. Chandler & Co. much time was spent by the attorneys in an interview

with a party desiring to purchase the claims represented by them before a definite basis of settlement could be decided upon, the final arrangement being consummated upon the moment when it was found the conference was liable to prove fruitless, our own attorneys assuming responsibilities which they deemed the necessity and importance of the case demanded without waiting for the same to be ratified.

Without desiring to bestow fulsome praise, or to even detract from the credit of any person in the results that have been attained in the investigation and final settlement of this case, yet it should not go unmentioned that a VERY LARGE share indeed is due Messrs. Vose and Barton, members of the committee, for the untiring energy displayed by them in its consummation.

The matter of extending credit to parties generally reported unfavorably is one which should receive more careful attention than is often bestowed upon it, thereby avoiding losses which otherwise generally occur. We have been assured by a member that since his connection with the Board there are orders on his books of more than \$5,000, from firms who being reported unfavorably have since assigned and never paid a dollar of their indebtedness.

People of this character who have no conscience and are always ready to "swear at a mark," do not have much difficulty in getting their property out of the reach of their creditors. The only way the true condition may be known is by instituting supplementary proceedings after judgment. Suspicion amounts to nothing in a legal sense; it must be corroborated by actual knowledge of the facts, proven to the satisfaction of the court. In most cases laws concerning arrest in civil actions are so lax, that the remedy is now almost useless, and it goes without saying that there is no benefit in procuring a warrant of attachment, even if you can make out a preliminary case of fraud, unless there is some property in sight to lay your hands on.

The subject of overdue accounts is one that has presented itself very forcibly in the several claims which have been submitted for collection.

Is not the tendency of thus delaying settlement rather to encourage people that manufacturers are not particularly anxious about receiving their due, and thus inculcate a habit of tardiness which results disastrously. Many accounts have thus failed of being realized simply because they were not closely looked after, and other parties have stepped in and consumed all there was, or the debtor assigns and all is lost.

It may be appropriate in closing to allude to the decease of one of our oldest manufacturers, who, after a busy and well-spent life, has passed on to the other shore before. Alfred S. Potter, late of the firm of Fanning & Potter, of this city, a co-partnership which existed for thirty-two years.

Besides being identified with organizations of the trade, being at the time of his decease president of the N. E. Manufacturing Jewelers' Association, he was for a number of years in public life as a member of our Common Council, holding positions of honor and trust as a member of that body.

A familiar face is missed; no more will he be greeted by his friends and associates. All that was mortal of him has ceased to live, and is even now as the dust of mother earth. For the present, helplessly contemplating the mysterious void created by his departure, we can only say, "Farewell until the close of our own earthly lives, a long, a fond farewell."

Respectfully submitted,
MARCUS W. MORTON, *Secretary.*



[FROM OUR SPECIAL CORRESPONDENT.]

WATCH FACTORIES FOR THE GATE CITY.

ATLANTA, January 12, 1889.

All of our merchants, not only in the jewelry line, but in every branch of trade, after winding up old matters, have entered afresh for the work that is ahead of them. Of course, the past month has been the best one for trade of all the months in the year. It is the holiday or bric-à-brac trade, and usually good profits were had on the merchandise sold. At present trade in that line is fair for January. The jewelers are selling a good many diamonds and watches. Trade in the South is periodical—it has its ebb and flood like everything else.

The Manufacturers' Association, of this city, has had a proposition from a Northern man, relative to locating a large watch and clock

factory here. It is probable that the factory will be built, as the citizens of this city are intensely in earnest in the bringing of establishments of this character here. In addition to this one it is probable that the Hansen Watch Company will locate here also. This is just what we need. The South needs factories of all kinds and especially in this line. Watches can be made as cheaply here as they can in the North and West. In fact, there are many advantages, many inducements for the investing of capital in this branch of industry in this city. We, with open hearts, welcome all good people. We need their help and encouragement.

Now, as to the real status of trade in this city for the past month, we can say that it has been fair. The firm of J. P. Stevens & Bro. are becoming large advertisers, and sell their goods all over the South. They do strictly a retail business.

It is said by salesmen who visit Atlanta that Freeman & Crankshaw have the prettiest retail store in the South. This is a compliment, indeed, but no doubt it is well merited.

E. W. Blue, on Beachtree street, jeweler, has been making a big fight against watch clubs. He does not like that system of doing business and does not hesitate to condemn it.

A. F. Pickart is now in his new headquarters at 55 Whitehall street, and has a pretty store.

F. S. Doyle, who was closed out some months ago, has connected himself with F. J. Stilson.

One of the youngest practical jewelers in the South is Charles Anderson, of this city. He is way down in his teens yet, but has mastered his profession. He has had several fine offers to go to New York, and it is likely he will accept one of them. T. J. K.

Insuring Registered Mail.



THE HOME Insurance Company will enter upon the new year with an added department, which is of special interest to the business public all over the country. This new department has been established for the purpose of insuring money, bonds and securities, as well as packages of merchandise sent by registered mail.

The insurance of this matter amounts to an absolute guarantee on the part of the Home Insurance Company, that the package or letter covered will either be delivered to the addressee, with contents intact, or paid for in whole or in part, to be determined by the amount of actual loss.

The insurance begins simultaneously with the receipt by the insured or his agent, of the usual certificate of the postmaster, indicating that the package has been deposited in the post office for registration, and continues until the post office employees at the office of destination have delivered it to the addressee or his constituted agent. The plan adopted to effectuate this insurance was determined upon after mature deliberation, and was the outcome of careful inquiry and frequent and exhaustive consultations with those most competent to advise.

The effort has been to simplify and minimize the details so that the policy holders can have the benefit of insurance with as little red tape formality as possible, consistent with a due regard for the protection of the company. It is confidently believed that in this respect, as in all others, the plan will commend itself to banks, jewelers and others, as being free from annoying complications and therefore perfectly practicable. This department, which will be designated as the Postal Insurance Department, will be under the immediate supervision of gentlemen who have resigned prominent positions in the government postal service, and whose large and

varied experience and practical knowledge of post office methods especially fit them for the work.

The idea of covering valuable matter, transmitted through the mails, with insurance, is not a new one on either side of the Atlantic. A few companies have done such business, but their operations have been confined to comparatively narrow limits. In the United States the government assumes no liability for loss. On the other hand it is expressly understood that the government is not responsible for the loss of any article transmitted through the mails, whether registered or not. Registered mail matter has no declared value so far as the post office is concerned, and no recovery can be had from either the government or postmaster in the event of loss. In view of these facts the new departure of the Home Insurance Company is neither strange nor of doubtful propriety. It is simply an intelligent recognition of an opportunity to push its business along lines which have been thoroughly investigated both as to demand and safety.

With a plan so well considered, and at the same time so comprehensive that it will meet every reasonable business demand, and with unequalled facilities and equipment for its fullest development, there is every reason to believe that it will recommend itself to the favorable consideration of business men everywhere.

How to Test for Magnetism,

In Watches, in the Shop, on the Cars, and on the Person.

BY "EXCELSIOR."

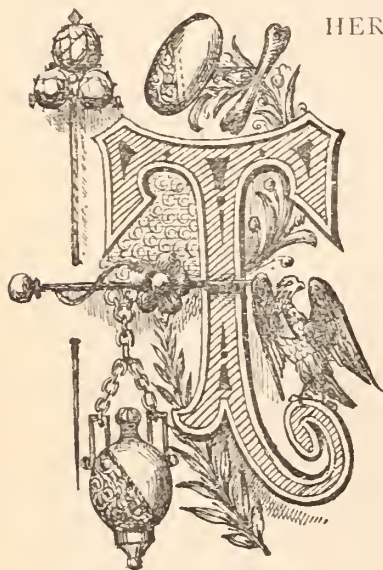

HERE seems to be a tendency in some quarters to underestimate the injurious effects of magnetism upon the performance of watches—to make out that there is but little danger of a watch becoming magnetized, and so on. These ideas are so very far from being correct that I have felt impelled to give the trade the benefit of my experience in that line. I do not propose to write a theoretical disquisition on electricity and magnetism, but to tell practical workmen in a plain, practical way how they can make some simple "testers," at a cost of a few cents for materials, by which they can test for them-

selves any watch or any part of it, and can also ascertain whether there is any magnet in its vicinity acting upon it.

But first, a few words about the prevalence of magnetism and its effects. Many persons think that a watch will not become magnetized unless it is exposed to a powerful dynamo, which will seldom occur, so that they may as well run their chances and not bother themselves about non-magnetic watches or devices. This is a great mistake. Taking into account all the watches in use, good and poor, new and old, it is doubtful whether there are as many as *two out of a hundred* free from magnetism. Does this seem startling? Think for a moment, and you will see that they may be magnetized when they come from the factory, unless special pains are taken to prevent it. The tools and machines with which they are manufactured may be magnetized, and the various steel parts may become so even after they are finished—in putting up, adjusting, etc. Then they pass through the hands of the agents, jobbers and dealers, with all the risks of exposure during the packing, selling and shipping here and there, until they finally come to be examined or "overhauled" in the retail dealer's shop.

And how is it there? I have worked in and visited a good many

shops, east and west, and I candidly doubt whether there are a dozen repair shops in the country where the bench tools and the stock of materials are free from magnetism. Who has not seen the familiar "horseshoe magnet" lying on the bench among the tools; or kept in the material drawers in actual contact with the mainsprings, or case springs, or watch keys, etc.; or used for picking some lost steel piece out of the dust heap? In the old days nobody thought there was any harm in that—and very few fully appreciate the harm of it even now. Yet the fact is that each magnetized piece magnetizes every other piece that it touches, till all are more or less affected, and every watch handled with magnetized tools is contaminated. Actual contact is not necessary, for a magnet will magnetize a piece of iron or steel *near it* by "influence." As the watch hangs on the rack or lies in the show case it is influenced by every magnetized piece in its vicinity, according to their distance and the strength of their magnetism. Every screw, nail, or piece of iron or steel, the locks, the sash weights, even the safe in which it is kept nights, may be magnetized, and will not only affect the running of the watch but will surely magnetize it. Instead of there being but little danger of the watch being exposed to magnetic influences, the trouble is to find a place which is *free* from them.

A watch which is magnetized will be affected by *every piece of iron or steel* which comes near it, even if the latter is *not magnetized*. Let us see how that can be so. I cannot here explain fully the principles of magnetic action which are concerned in this case, for that alone would require one or two entire articles, and the following brief statement must suffice for the present. I may return to this subject at some future time. My remarks will refer to ordinary watches, not provided with any protecting devices for magnetism. A discussion of the different anti-magnetic inventions would involve personalities and be foreign to our present purpose, which is a general explanation of the whole subject, not the treatment of special and exceptional cases. In speaking of the "parts" of a watch, I mean those made of magnetic metal and therefore liable to be magnetized. Those of iron and steel are the most so, nickle is slightly magnetic, cobalt, aluminum and platinum are less so, and copper, brass, zinc, gold, silver, glass and paper not at all.

Whether the watch is magnetized or not, it will be affected by any magnet in its vicinity. If it is free from magnetism it will not be affected *so much* as if it were magnetized, but the difference is less than might be expected, for this reason: a piece of iron or steel when exposed to a magnet becomes "magnetized," and while so magnetized *it is a magnet*. A watch cannot be exposed to magnetic influence without being affected thereby, that is to say, it will *necessarily* be magnetized. Those parts of it which are made of perfectly soft or annealed pure iron will lose their magnetism when magnetic influences are removed, *i. e.*, they are only temporarily magnetized. But those made of hard or impure iron, or of steel, especially compressed or tempered steel, will retain more or less of their magnetism, even after all external magnetic influences are withdrawn, and every such part is then a "permanent magnet," with its north and south poles and magnetizing powers acting upon the other parts according to its strength, position and distance. As a necessary consequence, if a single part in a watch is permanently magnetized, the other parts will be *kept magnetized* by it. Thus a magnetized mainspring, case spring, pinion, or even a screw, may contaminate the entire watch.

Hardened and tempered steel is less easily magnetized than soft steel, but, on the other hand, it retains its magnetism longer and more tenaciously. When magnetized to a certain strength, it will retain the polarities so produced in it, as against a weaker magnet which tends to produce the opposite polarities in it; whereas, a softer piece exposed to the same conditions might have its polarity reversed thereby. A very soft piece will have a polarity according to every magnetic pole presented to it, and may reverse its polarity hundreds of times in a day. And while it might be *possible* to regulate a magnetized watch, if its condition would remain unchanged, it is evidently out of the question to regulate a watch which is lia-

ble to be radically changed every hour, minute or second in the day. This is not an improbable occurrence but an ever present danger, for every one knows that the steel of the balance is comparatively soft, and of all the parts in the watch that is the one which *must* be protected from magnetic disturbances if we want a decent performance, or any performance at all.

As before stated, a magnet can magnetize a piece of steel or iron both by contact and without contact. In the latter case it is said to magnetize by "influence," *i. e.*, at a greater or less distance from it. Some powerful dynamos are said to magnetize a watch twenty feet away. Electric motors act like dynamos in that respect. Weaker magnets produce less effect, but even a little hand magnet can be felt several feet, and every piece of iron or steel within the circle of its influence is at least temporarily magnetized *i. e.*, it becomes a mag-

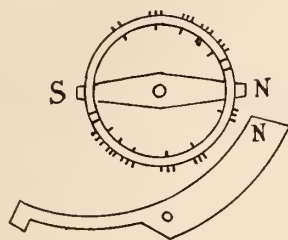

FIG. 1.

net. The different portions of a magnet have different properties or polarities, and, to distinguish them, are called north and south "poles." The poles are generally at or near the ends of the piece. But in case of a long piece or a ring there may be several poles. Thus a balance may have a north pole at one end of the center bar and a south pole at the other end. The poles may be located somewhere else in the rim, or there may be several poles around the rim. In a long piece like a mainspring, there may be a considerable number of poles, alternately north and south, around it. A north end or pole will repel another north pole, but attract a south pole, *i. e.*, "like poles repel but unlike poles attract each other."

Magnetism is the most injurious in watches when it affects the balance, for that is the part whose motion is most easily disturbed and most desirable *not* to disturb. Magnetic attraction upon parts outside of the escapement is of very little consequence, but *their* magnetic action upon the balance is very important indeed.

Now just imagine a magnetized balance vibrating one-eighth of an inch (or less) from a magnetized case spring, or balance cock screw, or center pinion, or any other steel piece, as shown in fig. 1, which represents the simplest possible case, where the balance has but two poles, N and S. Whenever the N part of the rim approaches the N end of the case spring it is retarded or opposed, but after passing the end of the case spring it is driven forward or accelerated by the repulsion of the latter. When the S point of the rim approaches, it is attracted and pulled forward, but, after passing the case spring, the attraction of the latter holds it back. These disturbances are most energetic, of course, when the poles of the two pieces are passing, and nearest together. The number of times these accelerating and retarding actions take place in each vibration of the balance will depend on the amplitude of the vibration and the number and position of alternating polar points in the rim, and will evidently be different as the watch runs down more and more. It is not necessary to explain further, for everyone can mark out any combination of polar points he chooses, on the cut, and study out the effects for himself.

It is perfectly clear, however, that the balance cannot have that regularity of motion which is essential to timekeeping. Its motion is not controlled by the hair spring, as it should be, but by outside influences which are unknown, uncontrollable and constantly changing. Add to all this the disturbing effect of every iron or steel object you meet, acting now from one direction and next from some other, and what kind of time can one expect from such a watch? Even when the effect upon the motion of the balance is not percep-

tible to the eye, the errors in the running may be so large as to render it a matter of no consequence whether the watch is adjusted for isochronism and temperatures or not, and the best expansion balance may act no better than one of plain steel. If the magnetism is at all powerful, the watch will stop.

Of course we cannot tell where the customer will wear his watch, but we can make sure that it is all right when it leaves our hands. Then if he comes back with a complaint about its running, we can test it again, and if he has exposed it to magnetic influences powerful enough to injure its running, it will show the effect of it by retaining more or less magnetism in its steel parts, which we can detect by our testing needles.

To make our testers we need only some soft iron wire, and some very flexible fiber to suspend our needles with. Fig. 2 shows a pair of needles suspended from the ends of two handles, which may be sticks of pegwood. When not in use the sticks may be stuck in a flat cork, for a "stand." The whole may be covered by a glass to keep the dust off, or put in a paper box.

For our suspension we may take some sewing silk twist, and separate it into fine filaments, or we may pull one out of a ribbon. The fiber should be sufficiently long and fine to have no stiffness or twist, and to allow the needle to *turn freely in any direction.*

tools, etc. Then cut off two pieces of finer binding wire, one inch long, for testing watch parts for very feeble traces of magnetism. We have a *pair* of each size, for testing each other, that we may be sure that our needles are themselves free from magnetism. To distinguish the ends, we leave one end square and point the other. Get the needles straight and *finish all work* on them before annealing.

Anneal thoroughly, in any convenient way—for instance, heat two bricks red hot, put the needles on top of one, cover them with the other, cover the whole with coals and ashes and let the pile cool as slowly as possible. Two iron blocks may answer instead of bricks, or even two red hot pieces of charcoal, if need be.

When cool, tie the silk around the middle of each needle, and hang to some support, say pegwood for the short needles. The longer ones may have a foot of silk, and hang from a wire of brass

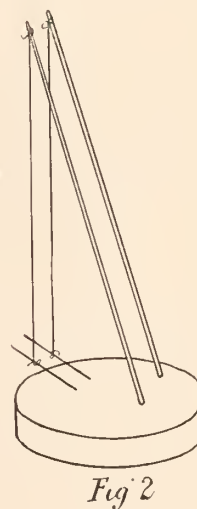

Fig 2

For our needles we take some fine iron wire, say ordinary binding wire, somewhere about No. 20. or $\frac{1}{32}$ inch in diameter, and cut off two pieces about two inches long. These are for testing the shop, or other non-magnetic metal. If you *know* that your needles are of good iron and are properly annealed, they are now ready for use. But if you are not enough of an electrician to be sure of that, you will first

Test your needles. That may be done in different ways, but the following procedure will be simple and easy for the least experienced: Being sure that they are clean, *i. e.*, have no grease, moisture or dirt to make them stick together, hang the pair parallel, as seen in fig. 2, $\frac{1}{2}$ or $\frac{1}{4}$ inch apart, and see what they do. If they

hang perfectly still and indifferent to each other, you are a fortunate man—"one among ten thousand," for you have got your needles right the first time, and have a shop free from magnetism—at least, in that particular place. But they will probably attract each other and come together. There may be several reasons for this.

Static charge. In a dry atmosphere the needles may be electrified, or charged with electricity. If so, they will probably separate spontaneously in a moment. If they do not, gently press both needles between the *clean* thumb and finger, or touch them with a piece of non-magnetic metal; that will "discharge" them. If they still stick together, the attraction is not electrical, but magnetic.

Magnetic attraction between the needles may be due to their having been *permanently* magnetized by some magnet after the annealing, or they may be now under the "influence" of some magnet in their vicinity, *i. e.*, *temporarily* magnetized by it. In the former case the needles are not of pure iron, or not sufficiently annealed, or they have been *worked at* since the annealing. Hammering, filing, twisting or bending, may give even soft iron a little "coercive force," *i. e.*, power to retain magnetism. It is this force which enables tempered steel to retain so much magnetism and make such powerful magnets. We want none of it, and if our needles possess it they are not magnetism-detectors, but

Magnetized needles. They may be used to hunt after iron and steel, or to tell the polarity of magnetized pieces. Remembering that unlike poles attract each other, that part which is attracted by the north pole of a compass needle, or any other magnet, is a south pole. By holding such a needle over a balance and moving its point around the rim, its north pole will be attracted by those parts of the rim which are of south polarity and repelled by the north parts. Any other piece can be so tested.

Magnetism-detectors. A magnetized needle will point to any piece of iron or steel, whether it is magnetized or not. But that will not answer for our magnetism-detectors. We do not want to know whether there is any iron or steel in the watch, or on the bench, or elsewhere—for we can see it. What we want to ascertain is, whether that iron or steel is magnetized or not. Hence our needles must behave differently in the two cases: must be neutral or indifferent to metal which is not magnetized, and must be attracted to that which is, thus clearly pointing out to us which parts are magnetized and which are not. For practical working purposes, they must also be able to throw off all magnetism, or free themselves from it the moment that the external magnetic influences are removed, no matter how strongly or how often they have been magnetized, so that they may always be in working order. Only perfectly soft or annealed pure iron can do this, and even that must not be worked or compressed after annealing.

Test for permanent magnetism. Remove one of the needles and test the other with a permanent magnet—not a "horseshoe," but straight. A magnetized rod, nail, or even a knife blade, will do. Point the blade at your needle and bring it just near enough to cause one end of the needle to *point* steadily towards it, but *not* close enough to draw the needle towards it. Now turn your needle with its other end to the blade, with the fingers or a brass wire. If it is permanently magnetized, it will swing around to its former position; if only temporarily magnetized, it will point to the knife blade, *i. e.*, it will make no difference which end you present to the blade—either end will point to it, showing that the needle is properly made. But if one end points to the knife, and the other end is repelled by it and turns from it, that needle is either not sufficiently annealed or not pure iron. Anneal it thoroughly, then rub the point of a magnet gently over it from one end to the other, and test again. If one end is still attracted while the other turns away, as before, that iron is not suitable for our detectors. But if *either end* will now *point* to the magnet as above described, your needle is ready to use; and if two such needles will hang near each other (say $\frac{3}{4}$ the length of a needle apart) and not be attracted, you may conclude that there is no magnetism in their vicinity, at least not enough to do the slightest harm.

Test for concealed or unknown magnets. Remove all known magnets to a distance. If the needles then swing around till their ends meet (as shown in fig. 3) and stick together, there is still some magnet in their vicinity. As before stated, a magnet exerts what we term a magnetic "influence" in the space near it, or we may say that it fills the space around it with magnetism. This external or free magnetism will go through water, air, wood, paper, glass, metals, live flesh and blood—through anything whatever. Nothing can stop it. The space so affected is called a "magnetic field." So every magnetized tool or object produces its magnetic field around it, and every other piece of magnetic metal in that field is magnetized by it, according to the strength of the field acting upon it. It is this unseen influence which affects our detector needles and enables us to detect its source.

In fig. 3, the dotted lines may represent the position of the needles when unaffected by magnetism and swinging freely, as in fig. 2. When magnetism is present they become magnetized, opposite poles attract each other, and they assume the position shown by the full lines. The needles are greatly exaggerated in thickness in the cut, for the sake of clearness.

Testing the tools, shop, etc. To do this we let one of our large needles hang over the suspected tools, close to but not touching them, and move it slowly around till it shows a disposition to *point* at a particular spot. Let it down till the end touches the spot, and if it sticks to it that part is magnetized. Remove all such pieces as fast as found, till none remains. If our needle still *points* in one direction, when allowed to hang freely, there is magnetism "in the air," proceeding from some more distant magnet. To find it, move the

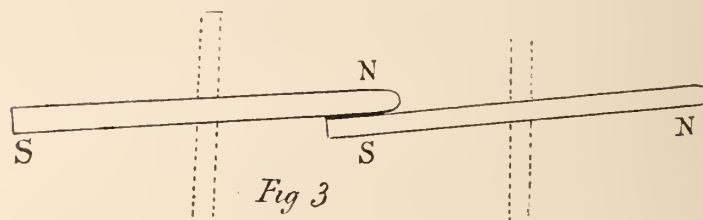

Fig 3

needle *straight forward* in the direction it points, till you come to the magnet. If the needle, when so moved, ceases to *point*, put it back again, let it *point*, and move it in the opposite direction, *i. e.* the other end forward. The needle does not necessarily point *towards* the magnet which is acting upon it—it may have almost every position, even *at right angles* to the direction of the magnet from it, if distant. But if moved straight ahead in the line of its axis, as described, it will gradually turn and finally reach the magnet. Electrically speaking, it follows along the "lines of force" to the magnet.

Testing railroad cars, locomotives, tracks, streets, stores, and other places, can be done in the same way, to satisfy yourselves how omnipresent magnetism really is. But as the magnetism we look for in such places is generally quite strong, it will not be necessary to have your needles suspended, but throw them loose, without the silk, into a small paper box twice the length of a needle, and shake them together. If they are in a "magnetic field" they will stick together, but if they are not under magnetic "influence" they will have no attraction for each other. One will be surprised to find how universally iron and steel objects are magnetized. Lamp posts, fire irons, lightning conductors, water and gas pipes, gates, railings, iron pillars and supports, and all objects which remain for a long time in an upright position, are magnetized by the earth's magnetism, with their north pole downward. They in turn magnetize other objects, in horizontal or other positions, by contact and by "influence." Then there are the dynamos, electric motors, conductors carrying strong electric currents, telegraph and other magnets, telephones, electric fire, burglar and other alarms, and the thousand-and-one other magnetic appliances in common use, all producing magnetic fields around them. The tendency is for all magnetic substances to become more

or is magnetized, and it is difficult for one to go anywhere without meeting magnetic "influence."

Test yourself, before making any of the other tests described in this article, to be sure that you have no magnets about your person while testing, as they would destroy the value of all your tests. Swing a needle slowly over the person, near to it. If it shows a tendency to *point*, move it more slowly from side to side before that spot, and it will turn itself to point at any magnetic object there. You can thus detect a magnetized artificial limb, truss, revolver, knife, bunch of keys, button hook, spectacles, etc. Even the buckles and buttons may be magnetized. Electricians have always known the necessity of removing all magnets from the person before testing, but it is probably new to watchmakers.

Testing a watch. Having now a place free from magnetism, you are ready to test your watches. First lay your suspected watch (case and all) under or near the suspended needles (fig. 2) till you have leisure. If the needles stick together, as in fig. 3, the watch is magnetized and should be put into the demagnetizer at once. If you wish to test the parts separately, swing one of your short needles over the movement, and let it down till the end touches the suspected part—for instance, the balance rim. Then gently lift it up, and if they do not stick together at all, touch other parts of the rim, then touch the other end to the rim. If there is no attraction between them, anywhere, the balance is not magnetized. In the same way you can test the other parts, or your material, before fitting in a new piece. If one part in a watch is magnetized, all the others will be more or less affected, and the whole should be demagnetized together, case and all, just as it stands.

To satisfy yourself or your customer that a magnetized balance is affected by every piece of iron or steel which comes near it, hold a piece of soft iron, free from magnetism, near it and observe the effect.

Test the customer. When you have got the watch free from magnetism, you can test the owner, to see if he is properly qualified to carry such a watch without injuring it. If you have a sense of humor you can make considerable amusement by telling him about your pointers and setters, bringing out your detectors, and searching him for concealed magnets. It is essential not only to do good work but to have your patrons satisfied and good natured, and a little innocent fun of this kind may do you more good than long arguments and explanations.

The Jewelers' Security Alliance

President, DAVID C. DODD, JR.

First Vice-President, AUGUSTUS K. SLOAN.....Of Carter, Sloan & Co.

Second Vice-President, HENRY HAYES..... Of Wheeler, Parsons & Hayes.

Third Vice-President, DAVID UNTERMAYER.....Of Keller & Untermeyer.

Treasurer, W. C. KIMBALL.....Of Strange & Brother.

Secretary, GEO. H. HODENPYL.....Of Hodenpyl & Sons.

EXECUTIVE COMMITTEE.

J. B. BOWDEN, *Chairman*..... Of J. B. Bowden & Co.

C. G. ALFORD..... Of C. G. Alford & Co.

N. H. WHITE.....Of N. H. White.

CHAS. G. LEWIS.....Of Randel, Baremore & Billings.

F. KROEBER.....Of F. Kroeber Clock Co.

SILAS STUART.....Of Silas Stuart.

EXAMINING FINANCE COMMITTEE.

EDWARD SMITH..... Of Smith & Knapp.

A. JORALEMON.....Of A. Joralemon & Co.

For further information, Application Blanks for Membership, By-Laws, etc., Address
P. O. Box 3277. 170 Broadway, New York

At the regular monthly meeting of the Executive Committee, held at the Alliance office on the 11th inst., there were present Vice-Presidents A. K. Sloan and Henry Hayes, J. B. Bowden, Chairman, Silas Stuart and Secretary Hodenpyl.

The following were admitted to membership: John E. Lomberg, 68 Main street, Ansonia, Conn.; Emil Holl, N. E. cor. State and Orange streets, Media, Pa.; Chapman & Jakeman, 132 Main street,

Norfolk, Va.; E. Fairchild & Co., cor. Main and Market street's Johnstown, N. Y.; The Newark Watch Case Material Co., 19 Ward street, Newark, N. J.; F. Berthaud, Milford, Pa.

Admitted December 19: Chas. S. Prey & Co, Greenwich, Conn.; S. K. Merrill & Co., Pawtuxet, R. I.

The Jewelled Carriages of Russia.



THE TRAVELER who visits St. Petersburg in the summer time, while the Emperor and his court are absent at Peterhof, is shown, among other curiosities, the wonderful collection of State carriages which are used at the coronation of each one of Russia's rulers.

Most of them are relics of the magnificence of Empress Catherine II., but every succeeding reign has added to the barbaric splendors of these jewelled coaches. The first object that strikes the eye is a plain, but elegant, carriage of modern construction and style, painted dark blue, the whole of the wood-work on the back shivered and hanging loose, like the wooden slats of a blind, while the interior is a mass of torn cushions. This is the vehicle in which the late Czar was driving when the first shell, destined for his destruction, burst, leaving him uninjured but shattering his equipage. It was not until he stepped out into the street to ascertain the cause of the disturbance, that a second bomb annihilated the autocrat of all Russia and his assassin, at one and the same moment. A chapel is now in course of erection by his son, the present Czar, to mark the spot where this dread catastrophe occurred. The mangled remains of the imperial martyr were placed, with his ancestors, in the church of Sts. Peter and Paul, and to this day his tomb is always covered with fresh flowers, generally violets—their perfumed breath mingling with the burning of incense and the smoke of the waxen tapers which surround the marble sarcophagus.

The next object of interest is a primitive sledge, fashioned by the prentice hand of Peter the Great, the worshipped hero of Russia. It is of wood, roughly constructed, painted dark gray, with coarse woolen cushions, and poorly lighted by small panes of glass. Alongside of this much-prized relic is the sumptuous sleigh, drawn by mimic swans of white and gold, in which once reclined the voluptuous figure of Catherine the Great. The sedan chair of the late Empress, who was for many years an invalid, is another curiosity, with its gilded doors adorned by the jeweled monogram of its royal owner, and its cushions of rose-colored silk. In the inner apartment the display of coaches is superb. About a dozen of these are gorgeously painted in red, and glitter with varnish and rich gilding, from the pole to the old-fashioned rocking springs in the rear. The tops of some of them are surrounded by ornamental borders, studded with jewels and surmounted by a crown set with precious stones. Diamonds, rubies, sapphires and emeralds outline the imperial monograms on the doors, and even the hubs of the wheels and the curving supports of the broad door-steps are set with the same brilliant gems. It seems almost incredible that this vast quantity of jewels should be genuine, but the uniformed cicerone gravely assures his visitors that they are all real stones of great value. The doors of one coach were painted by Watteau, and another by Boucher, precious pictures even more costly than old mine stones. Indeed, the guide affirmed, the British government has offered \$75,000 for one small panel by Watteau, which they wished to place in the National Gallery. This offer, however, has been refused, and the beauty of the coach, thus splendidly adorned, is still intact. For each coronation a new carriage is made, and all, including many in Moscow, are brought out for the grand pageant.

The present Czarina selected for her use, at the late coronation, a coach presented by Frederick the Great of Prussia to the Empress Catherine II. It is beautifully painted, richly jeweled, and cushioned in embroidered satin, with magnificent hammer-cloth and harness inlaid with gold.

The Mackay Jardiniere.



THE IMMENSE popularity which all articles in silver have attained is due not only to a cultivated and refined taste, but more largely to the unmistakable progress which has been made in the manufacture of the metal. It has already superseded gold in many lines owing to the many fanciful finishes and artistic treatments of which it is capable. Its handiwork and design has ably kept pace with its mechanical advancement, until now the most fanciful dream of the artist or ideal of the sculptor may be preserved in the ductile metal. An admirable instance of the silversmith's handiwork is the magnificent center piece or jardiniere designed and made by the Gorham Mfg. Co., and presented to John W. Mackay by the officers and staff of the Commercial Cable Company. The standard or base is a circular or concave piece twenty-two and a quarter inches in diameter, and supported upon four gracefully wrought standards.

Occident. The former carries a shield with the ancient Egyptian sun as a symbol upon it, while its characteristic look is that of indolent but warlike barbarity. The latter, however, is a figure in direct contrast. It bears a tablet showing the setting sun, and at the top a bat as the symbol of watchfulness. The pose of the figure is that of restless energy, and he leans forward, shading his eyes with his hands as he gazes expectantly into the future for the untold possibilities of coming time. All the figures show perfect modeling skill, and, at the same time, a departure from conventionalities. From the center of the base rises an ornate raffle upon which dashes and surges the foam of a restless sea, and in its center are three dolphins bearing upon their backs the globe. This affords the finest example imaginable of the art of etching and is geographically correct. Every country, with its divisions and boundaries in either hemisphere, is distinctly traced. Every mountain chain, every threading river, every city and town of



The interior of this concave base is gilded and glows with all the luster and sheen of a piece of gold satin. This is the jardiniere proper. Its rim is a fac-simile of a telegraphic cable with the many strands of wire closely twisted together. From this rim downward the sides afford scope for beautiful pierced and open *repoussé* work in fantastic but graceful curves and sprays, and the figure does not become tiresome to the eye as no attempt at set repetition is made. Over each standard sits in easy attitude an ideal figure symbolic of the four points of the compass, as well as typical of the countries indicated. North is a female figure holding a magnet and significant of the lode-star and its influences. South is likewise a beautiful female figure, but with an aspect more mild and luxurious. She holds tropical fruits in her hands and a waving palm leaf. East and West are male figures, thoroughly representative of the Orient and

importance, and every inlet, gulf or cape can be found and identified. The oxidizing is done with rare discrimination, and the various lights and shadows lend an intelligence to the whole piece which is its chief charm. The globe is divided at the equator, and can be used as a receptacle for fruits and flowers. The basin portion being gilded affords a brilliant and harmonious contrast to the balance of the entire piece, which is oxidized; but its chief charm and beauty will best be appreciated when filled with glowing flowers. On the globe is the following inscription: "To John W. Mackay, Presented by the Officers and Staff of the Commercial Cable Co., Dec. 24, 1888." The total height is nineteen inches, and in its manufacture 48c ounces of fine silver were used. Add to this its elaborate design and its elegant finish, and it forms a piece worthy to represent the high regard in which Mr. Mackay's friends hold him.

Lathes and Lathe Work.

BY THE MODEL WATCHMAKER.



IT IS WELL to remember our little device for ostensibly cutting ratchet wheel teeth, can be used for cutting almost any stem wind wheel. We left our cutter indefinitely described at our last interview, but will now fill out the deficiency. After getting out our piece of soft steel for a cutter, we drill a hole in it to fit our arbor as shown in fig 5, December number of this journal. We reproduce arbor and cutter at fig. 1 of the present issue for convenience. To make the description as brief as possible, let the

disc *B* for the cutter at first about $\frac{1}{8}$ of an inch thick and finish to $\frac{1}{16}$. The hole in it is $\frac{3}{16}$. File one side dead flat to go against the shoulder *d*, diagram *A**. Clamp the disc *B* firm with the screw *c* and washer *b*. Now, turn off the face of the cutter *B* up to the washer *b*, then remove the screw *c* and take off the disc *B*, and file the portion of the cutter under the washer *b* flat to the part we have just turned, as it is necessary to have the cutter so we can reverse it on the arbor *A* and have it run true. The edge at *a*, fig. 1, is also turned. The arbor *A* is shown separate at diagram *A** with the cutter removed. The part of the arbor where the cutter goes is turned a little short of the thickness of the cutter, so the washer *b* will firmly press the cutter against the shoulder *d*. Smear the cutter with a thick paste of Castile soap and heat red hot, and plunge edge-wise into cold water. For making a Swiss ratchet procure a piece of Stub's steel wire a trifle larger than the diameter of our ratchet, so we will have steel enough to work with. The length of the steel piece should be about $1\frac{1}{8}$ inches, and the best way in the present instance is to file the ends into cone points as shown at *e e*, fig. 2. This will probably necessitate new centers for our lathe, as only pointed centers usually come with American lathes. I advise making new lathe centers with hollow cones because it leaves a better end for our Swiss arbor, as will be explained further along. We place our piece of wire *D* in the lathe, using double centers, and turn the end at *n* into a slight taper which will just go into an old American

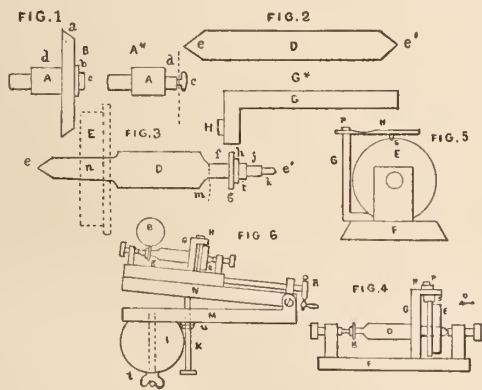

or imitation American barrel, as shown at the dotted line *E*, fig. 3. This barrel serves as a division wheel. We next turn the opposite end as shown; the part *f* is for the winding square; the part *g* for the ratchet; *h* the part which turns in the barrel bridge; *i* the part where the barrel turns; *j* the part where the mainspring collet or nut goes on; and *k* the part which turns in the barrel cover and where the stopwork goes. We turn these parts to near the proper size, except the part *j*, where the screw is cut; this is turned to exact size for the screw. This can usually be cut directly in the old nut. If it should not be hard enough, re-harden and draw it to a dark straw color. After the screw is cut and the nut fitted, the other parts are

turned to exact sizes, finishing with a bell metal slip and oilstone dust and oil. The stop wheel should also be fitted and the pin hole for holding it in place drilled; but the part above the pin is still left on to hold our arbor for cutting the teeth in the ratchet. A good number of teeth for a ratchet wheel is 30, and as an American barrel has usually 60 teeth, we can, by using every other tooth, use it for a division wheel, and by leaving the cover in we get a double bearing on the arbor *D* at *n*. In the December number we left the screws *j k*, fig. 3, for holding our arbor without any centers, and as we have made our arbor *D* with cone points, these screws must have conical pits in the end to receive the ends *e e*. For our present purpose all we need do is to conceive the arbor *D* placed between the screws *j k*, December number, with the end holding the ratchet to be cut toward the screw *j* and the old barrel we are to use as a division wheel in at the opposite end. We reproduce a portion of the cut at fig. 3, December number, at fig. 4, the only change being in letters of reference. For holding the division wheel in place while a tooth is being cut we will have to add a holding device which is very simple, and is made of a piece of heavy sheet brass bent into an L-shape. This piece is shown at *G*, figs. 4 and 5. In these figures fig. 4 is a side view and fig. 5 an end view seen in the direction of the arrow *a*, fig. 4. Diagram *G** shows the shape of *G* when first cut out; the bend is made at *r* and the holding spring is attached at *H*. The offset in *G* carries the spring *H* directly over the wheel *E*. The spring *H* is shaped as shown and can be made of steel or brass, and has a holding point which goes into the teeth of *E* as shown at *s*, fig. 5. In making this point it should be wedge-shaped and hold the wheel steadily in place. This is effected by not letting the wedge *s* go entirely to the bottom of the teeth. The position of *G* is well shown in the cuts. It is easy to make the spring detent or holder *H* so it is adjustable by a screw. This would not be necessary for ratchet cutting, but for cutting scape wheels like chronometers, etc., it would be indispensable. All this, however, will be subsequently considered; for the present we will content ourselves with our arbor and ratchet. At fig. 6 is shown the whole attachment applied to an American lathe, the bed of said lathe being shown at *I*. For holding the cutting device in place a screw *L* is used, which has a solid head *t* with a washer, while the upper end is tapped into the lower plate *M*, fig. 6. At *K* is shown a screw which is tapped through *M* but rests against *N*. This screw insures the depth to which the cutter *B* mounted on the lathe spindle centers the ratchet wheel. Below *M* on the screw *K* are two jam nuts *u*, which allow the screw *K* to be used repeatedly, and only rise the piece to be cut to a definite height each time. It will readily be seen that by means of the screws *K* and *R* the cutting action can be perfectly controlled. Suppose we wish to cut a simple ratchet wheel: we bring it squarely under the cutter *B* by the screw *R*, then raise the ratchet to be cut by the screw *K* until the tooth was as deep as we wished. Then run the jam nuts *u* up to *M*. By having two jam nuts at *u* we avoid having them change their place on *K*. Suppose, again, we were cutting a pinion (which can be done as well as a ratchet by having a proper shaped cutter); in this case we have a long cut to make in the direction of the axis of the arbor *D*. We get the depth to which the cut is to be made, then by using the screw *R* we can cut our pinion leaves one-fourth of an inch long if we desire to do so. How to make such cutters and use them will be considered at our next interview.

Obituary.

WILLIAM HOWKINS.

William Howkins, once prominent as a member of the firm of Carter, Howkins & Dodd, died of pneumonia at Newark, N. J., on January 1st, in the 65th year of his age.

He was born in Birmingham, England, and came to America at four years of age. When thirteen years old he left school to follow

variations to which this invention may be subjected at once suggest themselves. An alarm clock will doubtless be constructed which, at the appointed hour, will begin to deliver a gentle exhortation to 'Get up—it's 6 o'clock.' If the sleeper does not rise and check the clock, it will continue with gradually increasing emphasis, until it speaks in thoroughly unmistakable tones, spiced, if need be, with appropriate quotations from Scripture. Then the clock will have other combinations adapted for other purposes. The fond parent whose daughter is being sparked will have a clock which, at about 10 P.M., will sing out: 'Young man, it is about time you decamped.' A lady who gives parties will have a clock that will say: 'Good evening, ladies and gentlemen; it is bed-time,' and so forth. The phonographic clock is destined to fill a long-felt want."

Precious Stones in the United States.

BY GEO. F. KUNZ.

[From Mineral Resources of the United States, 1887, published by the United States Geological Survey.]

Continued from page 75, January, 1889.

Watch jewels.—About 1,200,000 watches with jeweled works are annually manufactured in the United States, requiring about 12,000,000 jewels, 7 to 21 for each watch; of these 5,000,000 are ruby and sapphire, and 7,000,000 are garnet jewels, valued at over \$300,000. Most of them are imported, but the Waltham Company does its own cutting, employing in this department about 200 hands, under the superintendence of Mr. W. R. Wills. About 15,000 karats of bort, in powdered form, are used annually in slitting and drilling these jewels. Nearly all the ruby, sapphire and garnet used for jewels are imported, but it is hoped that American materials will soon be used. To be of value for this purpose, the material must be of some decided shade of red or blue, of a hardness greater than quartz and free from flaws.

During the last decade new stones have come into favor, some neglected ones have regained their popularity, and still others, such as the amethyst and cameos, have been thrown out entirely. The latter, no matter how finely cut, would not find purchasers now at one-fifth of their former value; about ten years ago they were eagerly sought after at from four to twenty times the present prices. Rubies were considered high ten years ago and a further rise was not looked for, but to-day they are still higher, a $9\frac{5}{16}$ karat stone having been quoted at \$33,000. There is no demand at present for topaz, yet a syndicate of French capitalists has been organized to control the topaz mines of Spain in the expectation that after twenty years of disfavor this gem will again be popular. Coral has felt the change of fashion, for during the last three years the imports have been less than \$1,000 per annum, and in the last ten years in all \$33,956, whereas in the ten years preceding, \$388,570 worth were imported. The popularity of amber, on the other hand, is increasing. The imports of amber beads for the ten years, 1868 to 1878, amounted to less than \$5,000, whereas during the last ten years \$35,897 worth have been introduced. Amber amounting to only \$47,000 was imported from 1868 to 1878, but over \$350,000 worth from 1878 to 1888. Brazilian pebbles worth \$65,000 have been cut or sold ready for re-grinding since 1878, and less than \$3,000 in the ten years preceding.

Ten years ago few of our jewelers carried more than the following stones in stock: Diamond, ruby, sapphire, emerald, garnet, and occasionally a topaz or aquamarine. The gem and mineralogical collections contained a large series of beautiful stones, hard and of

rich color, but known here as fancy "stones," and by the French as *bijoux de fantaisie*. Since then considerable interest has centered in these fancy stones, and any leading jeweler is not only expected to be familiar with, but to keep almost all of them in stock. This change may be partly referred to the fact that since the Centennial Exhibition art matters have received more attention among us than before.

The Duke of Connaught gave his bride-elect a cat's-eye ring as an engagement token; this was enough to make that stone fashionable and to increase its value greatly. The demand soon extended to Ceylon, where the true chrysoberyl cat's-eye is found, and stimulated the search for them there. In the chrysoberyl cat's-eye the effect is the result of a twinning of the crystal, or of a deposit between its crystalline layers of other minerals in microscopic inclusions. If the stone be cut across these layers *en cabochon*, or carbuncle cut, as it is called, a bright line of light will be noticed on the dome-like top of the stone. In price they range from \$20 upwards; exceptional stones have sold at from \$1,000 to \$8,000.

In the search for these chrysoberyl cat's-eyes an endless series of chrysoberyls has been found, of deep golden, light yellow, yellow green, dark green, sage green, yellowish brown and other tints. They are superb gems, weighing from 1 to 100 karats each, ranking next to the sapphire in hardness. They gave a great surprise to the gem dealers; for it was found that the darker leaf green or olive green stones possessed the wonderful dichroitic property of changing to columbine red by artificial light, the green being entirely subdued and the red predominating. They were, in fact, alexandrites, a gem which had formerly been found only in Siberia, and even there of poor quality; though found in large crystals, a perfect gem of 1 karat was a great rarity. Here, however, fine gems but rarely under 4 karats were found, and an exceptional one weighed 67 karats. They can be numbered among the most remarkable gems known. Strange to say, among this alexandrite variety a few have been found which combine the characteristics of the cat's-eye and the alexandrite, and were, accordingly, named the alexandrite cat's-eye.

Moonstones also from this same province of Kandy, Ceylon, were brought to light by this search for cat's-eyes. It would not be an over-estimate to say that 100,000 of these stones have been mounted here in the last four years. They vary in size from one-eighth of an inch to nearly 2 inches long and 1 inch thick, and many of them surpass anything hitherto known of their kind in beauty and size, selling from 50 cents to \$100 each; in a few exceptional cases \$150. Those displaying the *chatoyant* white and the opalescent blue color are especially beautiful.

The demand for the cat's-eye also brought into demand the then rare mineral from the Orange river, South Africa, known as crocidolite, more especially that variety that has been altered to a quartz cat's-eye. In this stone an infiltration of siliceous material coated each fiber with quartz or chalcedony, giving the hardness of 7. This pleasing stone readily sold for \$6 a karat, and at the outset for even more; but owing to the excessive competition of two rival dealers, who sent whole cargoes of it to the London market, the price fell to \$1, or even to 25 cents per pound in large quantity. Even table tops have been made of this material by veneering. Vases, cane heads, paper weights, seals, charms, etc., were made of it and sold in large quantities. Burning it produced a bronze-like luster, and by dissolving out the brown oxide of iron coloring an almost white substance was obtained, which was dyed by allowing it to absorb red, green and brown colored solutions. These, owing to the delicacy of the fibers, were evenly absorbed. Ten years ago this material was practically unknown, but so extensively has it been sold that to-day it is to be found at every tourist's stand, whether on the Rigi, on Pike's Peak, in Florida, at Los Angeles, or at Nishni Novgorod, showing how thoroughly organized is the system of distribution in the gem market. The green quartz cat's-eye from Hof, Bavaria, has also been brought into use and quite extensively sold, but at

present both these varieties are only used in the very cheapest jewelry.

Since it has become generally known that Queen Victoria is partial to the opal, the old and stubborn superstition concerning it, which is said to date from Scott's "Anne of Geierstein," has been slowly yielding, until now the gem has its share of public favor. During the last two years ten times as many opals have been imported as were brought here during the preceding decade, many of these being the fine Hungarian stones. Mexican fire opals are much more common, as those tourists know to their sorrow who buy these stones at exorbitant prices in Mexico, hoping thus to pay the expenses of the trip, until they find on reaching New York that they are worth only about a quarter of what they paid for them.

The opal mines of Mexico are situated on the Hacienda Esperanza, near Queretaro. It is believed that a demand of 50,000 stones per annum could be supplied without raising the price perceptibly.

The opal mines of Dobreck, Hungary, yield the government a revenue of \$6,000 annually. The output is so carefully regulated that the market is never glutted.

About ten years ago a new and very interesting variety of opal was brought from the Baricoo river, Queensland, Australia, where it was found in a highly ferruginous jasper-like matrix, sometimes apparently as a nodule and then again in brilliant colored patches, or in specks affording a sharp contrast with the reddish brown matrix, which admits of a high polish and breaks with a conchoidal fracture. Many of these stones are exceedingly brilliant. They are of the variety known as harlequin opals, their color being somewhat yellow as compared with the Hungarian stone, although not less brilliant. The rich ultramarine blue opal is quite peculiar to this locality, and the green variety almost transcends the Hungarian. A company capitalized at £200,000 has been formed and the gems are extensively mined. Many curious little cameo-like objects, such as faces, dogs' heads and the like, are made by cutting the matrix and the opal together.

Green beryls, blue and green sapphires, white and bluish topaz, garnets and zircons have been found at New England in New South Wales, and precious opals are obtained from the Abercrombie river.

During the last ten years the taste for collecting jade and other carved hard stone objects has greatly increased, especially among Americans, owing to the stimulus given by the Centennial, Paris and Amsterdam expositions, and the breaking up by sale of many of the large collections. The value of carved jades outside of China and India can not be far from \$2,000,000.

In the United States there are, perhaps, twenty buyers who have purchased fully \$500,000 worth of this material, many of the pieces being among the finest known, such as the private seal and other objects from the sacking of the Emperor of China's summer palace. The finest pieces, brought over by Tienpau, included some of the best that ever left China, and were intended for the Amsterdam exhibition; the choicest specimens of the Wells, Guthrie, Michael and Hamilton palace collections are now owned in the United States. Experienced agents have been frequently sent to India and China to secure the finest objects as they presented themselves. One collection alone is worth over \$100,000; single objects sometimes selling for over \$5,000, and one exceptionally fine specimen being valued at over \$10,000. Explorations in Alaska have brought to light the fact that jade was used by the natives for implements, and it is almost proved that it is found not only as bowlders but also *in situ*. The National Museum, the Emmons, Everett, Peabody Museum, Canadian Geological Survey, Dresden, and other collections, including the writer's own, contain several hundred objects, at least, that are made of this Alaskan material. A fact of interest in this connection is that Prof. F. W. Clarke found among the objects collected for the National Museum one which, on analysis, proved to resemble pectolite so closely that he referred it to that species. It has the hardness of jade, a specific gravity of 2.873, and is pale green in color. The same discovery was made almost simultaneously by foreign observers.

The theory that jadeite or chalchihuitl was highly prized by the aborigines has been greatly strengthened during the last ten years. Prof. J. J. Valentine, in his paper before the American Antiquarian Society, April 27, 1881, on the Humboldt celt or votive adze and the Leyden plate, two remarkable carved jadeites, offered some exceedingly interesting suggestions. The Humboldt celt was presented to Humboldt by Del Rio in 1803, and the Leyden plate was given to that museum by A. S. Von Bamm, who found it near St. Felipe, close to the borders of Guatemala, in Honduras. They are both 9 inches in length and $3\frac{1}{4}$ inches wide; the former $1\frac{2}{3}$ inches in thickness, and the latter only one-fifth inch. This similarity of dimensions suggests to me that the two objects were originally part of one and the same celt. Before the same society, in April, 1886, Prof. Putnam exhibited his remarkable series of Nicaragua and Costa Rica jadeites, which were all ornaments made by cutting into halves, thirds or quarters one large celt perforated by one or two drilled holes, in one instance two of them fitting together. The 16-pound adze exhibited by myself at the American Association for the Advancement of Science meeting of 1887, from which fully two pounds had been cut; the breastplate recently found measuring only one-half inch thickness; and the fact that even Burmese jadeite, when burned or exposed to a high temperature, will assume the grayish-green color of the Mexican, all tend to support Prof. Fisher's theory that this jadeite originally came from there. Additional evidence is the striking resemblance between the Maya and ancient Burmese styles of carving, although Dr. Meyer, of Dresden, firmly believes that this material will yet be found *in situ* in Mexico. The imperial jade quarries of Burmah, in the Mogung district, 90 miles from Bhamo, are leased by two companies, who pay a royalty of \$30,000 annually. The trade is entirely in the hands of the Chinese. At the Colonial Exhibition in London in 1886 there were exhibited large rounded and water-worn blocks of jade, weighing hundreds of pounds, called panam by the Maories. Much of it is of the finest green color and was worked into charms, knife handles, etc. Dr. W. Buller exhibited a fine collection of Maori ornaments and clubs, or neeris, heitikas, and other native ornaments made of this stone.

Collections of gems.—A regrettable dispersion of jewels and precious stones took place in May, 1886, when the famous collection formed by the late Henry Philip Hope, and exhibited at the South Kensington Museum for many years, was sold at auction. The Hope collection included the "Saphir Merveilleux" of Madame de Genlis's "Tales of the Castle;" the King of Kandy's cat's-eye, the largest known, having a diameter of $1\frac{1}{2}$ inches; the Mexican Sun opal, carved with the head of the Mexican Sun God, and known since the sixteenth century; an enormous pearl, the largest known, weighing 3 ounces and measuring 2 inches in length; the aqua-marine sword-hilt, made for Murat, King of Naples; and also many curious diamonds, sapphires, emeralds, and several hundred unique and magnificent gems. Such a collection should have been preserved intact as a national possession.

In 1886 it was decided by the French Assembly that the Crown jewels, with the exception of the famous "Regent" diamond, two of the Mazarins and a few historic pieces reserved for the national museums, should be sold at public auction. These exceptions were made because it was feared that they would fall into the hands of Americans. The sale of this great historic collection took place in May, 1887. The forty-eight parcels were subdivided into one hundred and forty-six lots, and there were sixty-eight buyers; the sales to twelve of them brought over 100,000 francs each. The largest lot, the great corsage, which sold for 811,000 francs, was purchased by a single American firm, the largest buyer at the sale. The purchases of this firm amounted to 2,249,600 francs, or about 34 per cent, of the entire sum realized; while as to quality the same firm obtained more than two-thirds of the finest gems, among them being three Mazarins; a pear-shaped rose brilliant weighing $24\frac{3}{4}$ carats, for 128,000 francs; a pear-shaped white brilliant weighing $22\frac{1}{4}$ carats, for 81,000 francs; a white brilliant weighing $28\frac{7}{16}$ carats, for

155,000 francs; and an oval brilliant weighing $18\frac{1}{2}$ carats, for 71,000 francs; or 435,000 francs for the four. All but one of their purchases were secured by private American customers. The great interest attached to this sale was due not only to the fact that many of the gems were of very fine quality, but also to their historic associations; the history of many of them could be traced back several hundred years.

The collection of antique gems, numbering three hundred and thirty-one pieces, formed by the late Rev. C. W. King, of Trinity College, England, the greatest of all writers on engraved gems, was sent to the United States for sale in 1881. This collection represents the summing up of Mr. King's vast knowledge, and none has ever been more thoroughly studied. His numerous writings mark an epoch in the study of this branch of archæology, and only the loss of his sight led him to part with his treasure. The growing interest and taste in archæological matters in the United States induced him to send it here to be sold intact. In October, 1881, through the friendly mediation of Mr. Feuardent, it was purchased and presented to the Metropolitan Museum of Art by Mr. John Taylor Johnson, the president of the museum, where it now remains. Near it will be placed the Sommerville collection. Mr. Maxville Somerville, while spending the past thirty-two years of his life in Europe, Asia and Africa, has collected cameos, intaglios, seals, and other historical gems, and as a result of his liberal expenditure of time and money, he is to-day the owner of one of the most unique and valuable collections of engraved gems in the world. It numbers over one thousand five hundred specimens, including Egyptian, Persian, Babylonian, Etruscan, Greek, Roman, Aztec and Mexican, glyptic, or jewel-carving art. All of these are represented by specimens of singular excellence, affording us a panoramic view of the achievements of civilized man in this direction. This remarkable collection, now at his home in Philadelphia, has been loaned to the Metropolitan Museum of Art, New York, where it will soon be placed on exhibition, and the public will be afforded every facility to study the beautiful achievements of the glyptic art.

Of greater antiquity and archæological value, because representing a period before gems were cut in the form of intaglios, is the collection of the Rev. W. Hayes Ward, consisting of 300 Babylonian, Persian and other cylinders. Two hundred of these he himself collected in Babylon and its vicinity, and sold to the museum at a nominal figure. Since that time he has collected 100 more cylinders. Many of them date from 2500 B. C. to 300 B. C., and are cut in lapis lazuli, agate, cornelian, hematite, chalcedony, jasper, sard, etc.

The death of Dr. Isaac Lea, of Philadelphia, in his 95th year, deprived the world of a great investigator in the field of precious stones. During the last twenty years of his exceptionally long and useful life, he devoted almost his entire time to studying the microscopic inclusions in gems and minerals, and the cabinet he left contains thousands of specimens of rubies, sapphires, chrysoberyls, tourmalines, garnets, quartz, etc., all of which he had subjected to the most rigid microscopic scrutiny, noting every interesting fact on the accompanying label. Only a small part of his work on this highly interesting subject has been published by the Philadelphia Academy of Sciences in two papers (in 1869 and 1876), but Dr. Lea made ample provision in his will for the publication of the remainder. His extensive collection of minerals and shells were bequeathed to the National Museum, and the gem collection to his daughter. Two months before his death the writer spent two hours with him examining a series of quartz inclusions, over which he worked with all the enthusiasm and brightness of youth.

One of the many benefits traceable to the New Orleans Exposition was the appropriation given to the National Museum for their exhibit. This was wisely expended by Prof. F. W. Clarke in the purchase of a complete series of precious stones many of which, although not expensive, are still the finest in the United States, from an educational standpoint. Since the exposition, many fine specimens have been added by purchase and donation, especially the

diamonds and pearls presented by the Iman of Muscat to President Buchanan, consisting of 138 diamonds and 150 pearls, all of good quality. The collection numbers about 1,000 specimens, and embraces almost every known variety of precious stone, many of them very fine examples.



[FROM OUR SPECIAL CORRESPONDENT.]

PEACE AMONG THE NATIONS AND IN THE ELEMENTS.

PARIS, January 5, 1889.

Business has been exceedingly brisk during the last month of the defunct year, and it even seemed to increase on the first day of 1889. This can easily be accounted for. We cannot recollect having enjoyed such splendid weather, in the winter season, for many years; and as temperature has a great influence on the spirits of French people, it ought not to be a cause of wonder that they should have felt much more liberal about their purchases. Besides, when the sun shines brightly through a clear atmosphere, it gives to everything a cheerful and inviting appearance. No mist throws a veil on the show-windows, the goods are set off to the best advantage, and the retailers, as well as their clerks, warmed up with the "new wine of the year," find more persuasive logic to convince the wavering purchasers. Yet, we must confess, that the principal reason of this great improvement in the state of business is the strong belief now generally prevailing that the peace of Europe is not likely to be disturbed for a long time.

Up to the 31st of December, manufacturers received no end of letters and telegrams, urgingly asking for goods that could not be found. Boxes containing something or other that might possibly answer the purpose, in the absence of the articles wanted, were set in all directions, showing, at least, the good-will of those applied to. It is certainly more difficult than it used to be to foresee in September what is sure to sell well at the end of the year. In consequence, when pressing demands come, they very often have to be met from a rather scanty stock. Then arises the necessity of working late at night, to execute the orders in time. These gradually increase, and, as this all takes place at a moment when all the good workmen are engaged, the hands must work with a feverish speed. It is a great wonder that in such hurry goods should be turned out so well finished and so perfect as they are.

If all the goods were made by machine work, there would be no serious delay in executing the orders. But in a country like France, where almost every one will have something which has not been seen, or, at least, slightly different from what is exhibited at other places, original handwork is absolutely essential. This, no doubt, develops to the utmost the ingenuity of our artisans. It also obliges the manufacturer not only to devise an unending variety of patterns, but to see, at a glance how they can be quickly and perfectly obtained, as he is seldom allowed the time to examine and try the best ways of doing it.

Among the many articles given as presents at New Year's time, we must particularly mention bonbon boxes, cigar cases, match boxes, jardinières, flower stands and pocket mirrors. Bonbon boxes are generally in oxidized silver, and gilt inside. Most of them are in repoussé work. The small-sized ones admit of many different shapes. We confess our preference for those in the Louis XIII. style, slightly curved on the side and gently rounded out near the base. They exhibit, as a rule, on the lid, a small spray of flowers

resting on a hammered background. If initials are wanted, they are made to represent bits of dead wood clumsily twisted into letters by the hand of a child and half buried in the ground.

Cigar cases and match boxes admit of an unlimited variety in decoration. Grévin's most audacious sketches are reproduced on some of them, but, for the main part, they show familiar scenes connected with smoking and drinking; a few are copies of Teniers' Chardin's, Van Ostade's, and Meissonnier's paintings. The work is done in etching, or aqua-fortis, repoussé, niello, enamel, etc. These small articles are, as a rule, beautifully finished, and can bear a very close inspection.

Jardinières of all sizes have sold well. Most of them are in stamped work and, consequently, can be had at a comparatively low price. When the stamper is made by a skilful hand, the ornaments turn out well, and have, for the ignorant, a thoroughly artistic look. But we must say that a great many, which appear rather elegant when seen at a distance, show very coarse at nearer view.

Cheap jewelry here deals very extensively at present (as in all the other countries) in charms, the meaning of which is very often a dead letter to those who buy or receive them. Rough imitation medals of old luck-giving saints, in oxidized silver, hang from the well-known bracelet jone, narrow and round like a thin cord. Those brand new relics are evidently made with bluntly-engraved matrices, intended to leave faint and worn marks, so as to render them worthy of the deepest respect. French people seem to have been the last to catch that mania, but we must confess that they are going in for it thoroughly.

Stamped jewelry must be the same all over the world. Those who make that kind of articles, reproducing each pattern by the thousand, must evidently send them direct or through the medium of factors, to all countries where they are likely to sell. Therefore we feel perfectly confident that the barbarous but coquettish damsels of Central Africa (I mean the accessible parts where the light of civilization has penetrated) are adorned with the very same brooches and ear rings which are the pride of our grisettes. A great variety of animals, savage and domesticated, are imitated in this branch of jewelry, some being very commonplace and a few quite original. A well-trained dog, apparently coming from market and holding in his mouth a basket made of vari-colored stones, has been a favorite for some time.

A paper knife, handsomely chased, is a very acceptable present. We have seen one with an Egyptian mummy for a handle, the flat base being engraved with arms or initials, so as to be used as a seal. Two wings, shooting up from behind the shoulders, are joined together above the head, and extend, gradually narrowing to the proper width of a blade.

Some cigar holders in amber are very elegant. We have seen one adorned with a serpent made of brilliants mounted with silver. The sparkling snake is gracefully curled round the holder, and the head slyly rests above the aperture, on the wider end.

The bracelet-watch is gradually finding its way to the second-class jewelry shops. We mean the retailing places visited by the bourgeois. It is there the center piece of the bracelet department. We have noticed one formed of two chimeras, whose serpent-like bodies are loosely entwined. The savage-looking faces, distorted by an awful grin, rest with their mouths wide open on each side of the watch.

Very elegant timepieces are exhibited at some of the best shops. One of them, in rosewood, gracefully curved in and out, is meant to be used as a chest of drawers, large enough to contain several packs of letters and a few small articles besides. It is rather wide at the base, and narrows gradually upwards. The dial encased near the top is framed with worked gilt bronze, and surmounted with a graceful figure in the same sunny metal, out of which are also made the griffin's claws supporting that stately clock.

It is reported that a young married lady, possessing a very large

fortune, has made up her mind to have made, at any cost, an absolutely perfect copy of the famous queen's necklace, which, at the time, was worth 1,600,000 livres, and numbered 540 large-sized diamonds. This dainty work will be executed after the drawings of Boehmer and Bassange, which, happily, have been preserved.

M. Bapst has just published a book of 700 pages on the "Diamants de la Couronne," in which he gives us many details of a high interest, as it ought to be expected from a jeweler whose family was appointed during 150 years to look after those royal relics. But you have heard so much about those jewels, that we think it advisable to postpone for some time our account of that valuable book. JASEUR.

Advice to Watchmakers' Apprentices.

BY A MAN WHO HAS SPENT TWENTY YEARS AT THE BENCH.



S I HAVE BEEN devoting my articles lately to the repair of those nuisances, chatelaine watches, I think I will continue by giving in this communication three other distinct descriptions for methods of repair. I do not mean by this three ways to do the same thing, but point out the cure of these ills to which these watches are subject. The first trouble. I will tell how to mitigate is when the barrel rubs the center wheel above and also interferes with the stem wind work and the dial wheels below. In such cases about the best way is to put the barrel in a stop chuck, and turn the seat when the barrel cover rests back so as to produce a thinner barrel carrying a narrower mainspring. Usually we will have ample room for mainspring power remaining. Care must be used when freeing out the barrel to keep the position of the barrel as regards up and down all right, so that it will run free when reduced in thickness. One thing of great importance in all kinds of watch repairing is to give all work a new look. Now, in this kind of watches they need an endless amount of tinkering and handling, consequently the steel parts soon get strained and rusty; this is particularly noticeable in the regulator. Most people judge by what they can see and grade their idea what you do by the appearance of the parts which meet their eye; consequently when taking in a watch of this kind if the steel parts are rusty call attention to it, and speak of the slovenly manner in which the watch has been repaired or handled. It only takes a few minutes to restore the steel polish, and you can get pay for that when the party who owns the watch would kick at a charge for new screws for the steel cap over the end stone. In regard to these same regulator screws, a conscientious watchmaker has more bother with these than with repolishing the regulator bar and steel cap. The best method is to lay in a stock of this kind of screws, so that you can match most anything. Then provide taps which will give a thread for your screws to follow. Most of these steel caps are soft, and if not, soften and tap out, then harden and re-polish. For pointing the new screws use a Swiss screw pointer, pointing with a fine file, following with a burnish file. Doing such jobs nicely and expeditiously is one of the best evidences of the skilful workman. Your botch will flatten and rivet in a screw, trusting to heaven and good luck that he will have no further bother with it. It takes but a few minutes to bring up such a job to standard if you have the proper appliances. We should always keep a gilding solution for re-gilding movements. This is a process which most workmen make a frightful fuss over, when, in

fact, it is a very simple and expeditious affair. It does not require a hot solution to gild a movement, and five cents' actual worth of gold is a heavy coat for an 18 size movement. Our most successful gilders do not use a hot solution when gilding movements in the watch factories. I urge the practice of these restorations as something of importance to the workman who makes a specialty of repairs, and cares to build up a reputation for superior work. Doing this sort of thing, and, as I said above, calling the customer's attention to it will have a sickening effect on a slovenly competitor, "for people will talk." I would not encourage by this a bragging way and lauding your own efforts, but quietly point out to your customer *your way*, and let him make the comparisons and do the disparaging. Screws to balance bridges is another proof of your botch. The screws for these miserable chatelaines are almost invariably badly fitted, and the one to the balance bridge being used most gives out first. *Squash it* is the first resort of your watch killer, by squeezing it in his vice. If that don't do he picks out of stock a screw and squares the end and forces it in. Don't do this; keep a good stock of screws and assort them to fit a tap you keep with that particular size of screw, and then turn the head to fit in a wire chuck in an American lathe. What you need for restoring regulators is a roughened glass slab on which you use oilstone dust and oil for grinding flat. Flattened pieces of pegwood will, with the oilstone dust and oil, soon remove any rust from the regulator bar. Throw the bar into benzine and rub carefully with pith to remove all the grit of the oilstone dust. Polish with a similar piece of pegwood, using diamantine and alcohol on a cork held in your vice. For polishing the steel cover to the cap jewel after grinding on the glass slab, use a piece of thick sheet zinc and apply diamantine alcohol. I suppose it is hardly necessary to

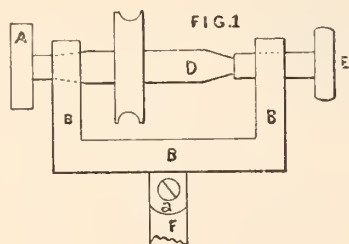

say you are to wash the steel jewel cover in benzine and peg out the screw holes to remove the oilstone grit before you attempt the polishing on the zinc plate. The third count in the suggestions for repair for these watches is the refinishing or damaskeening of the steel stem wind wheels, which finish adds so much to the looks of these watches. Any person having an American lathe with a countershaft can readily fit up a device for this kind of finish. I will first describe the general plan of such an attachment and then give the details. Suppose we have a wheel to finish in this way, we mount it on one lathe spindle, and instead of having the spindle revolve rapidly, we so arrange the connections of the driving wheel that the lathe spindle and the wheel to be finished turn very slow, not more than ten or twelve revolutions in a minute. The tool which produces the finish is a small disc or wheel of emery or corundum, about $\frac{3}{8}$ or $\frac{1}{2}$ of an inch in diameter, running with a velocity of ten or twelve thousand revolutions in a minute. This emery wheel is attached to the end of a small arbor running in U-shaped frame which is attached to a pin (by a point) which goes into the tool rest holder. The emery disc is shown at A, fig. 1, and the pin which goes into the rest holder is shown at E. It will not be possible for me to describe the whole attachment in this essay, consequently I will content myself with a few words on the practical use of emery wheels, as it is a subject which most of the craft should know more about. In this day emery grinding is one of the important means of shaping steel and other metals. Most men who attempt to use soiled emery wheels stop at too low a speed. The cutting surface of an emery wheel to do good work in dry grinding should move at a speed of about 5,000 feet in a minute—not less than 3,000—and the speed I gave for the little cutter is not

one-fifth of this velocity. I said ten or twelve thousand revolutions and this seems enormous for any spindle driven by foot power, but it really is too slow; still a corundum wheel of the size named will do very fair work. Emery should go quicker. Emery wheels used with water need go rather slow, but they will not produce a glittering surface such as we want in this instance.

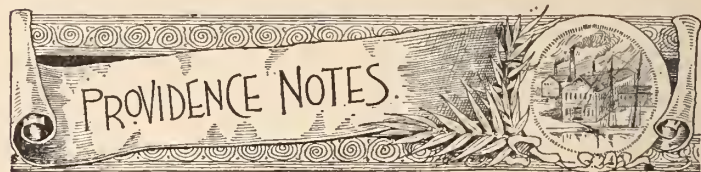

[FROM OUR SPECIAL CORRESPONDENT.]

PROVIDENCE, R. I., January 15, 1888.

The month of January did not start off with one of those skyrocket booms that have marked the season's opening of late, but a good conservative volume of business, which, if it holds out for the next eight or ten months, will make the year one to be remembered on the credit side of the ledger in seasons to come. The manufacturers generally are feeling very much encouraged at the bright prospects, and will take advantage of them to place as many goods on the market as are called for. Already the drummers first in the field are sending in satisfactory orders, which although not so large as are sometimes received, are placed in such a manner as to lead the manufacturer to infer that they will be paid for when the invoice becomes due, dollar for dollar, and not at twenty per cent. on the same.

The jobbing house of Stein & Ellbogen, Chicago, have agreed to discontinue their business. Their liabilities will be met as they become due, so they have notified the manufacturers in this city.

Walter Gardiner has moved to his new residence on Whitmarsh street, which is very cosy and pleasant.

Mrs. Charles S. Pine has asked the Municipal Court to appoint Charles S. Pine, Jr., as administrator of the estate of her late husband.

Frank E. Comey is home from Oskaloosa, Ia., where he is engaged in business.

J. D. Harrington, of Rochester, N. Y., who failed recently, owed to Providence parties about \$1,500.

Kent & Stanley, the enterprising jewelers of "Enterprise Block," report business in a very flourishing condition, with plenty of orders on hand to keep them running for weeks to come. This concern find their new quarters none too large to accommodate their fast growing business.

Charles Downs is again attacked by his old enemy, rheumatism, from which he has suffered more or less for a number of years past. His many friends hope to soon see him around again.

George T. Bynner has accepted the position of commercial man with M. L. Read, and will represent him in the West during the present year.

William H. Thurber, of Tilden, Thurber & Co., was elected a member of the Providence Board of Trade at its last meeting.

The last meeting of the late Board of Directors of the Jewelers' Board of Trade occurred on the 15th ultimo. The annual election took place on the 29th of December, at the rooms of the association at No. 9 Wilcox Building, and the following named gentlemen were elected for the ensuing year, viz.: B. A. Ballou, W. E. White, Wm. Fisher, Wm. R. Dutemple, N. B. Barton, D. Wilcox, Geo. L. Vose, H. S. Dorchester, Hiram Howard, T. E. Carpenter and R. S. Hamilton, Jr., all of Providence; J. L. Sweet, S. H. Bugbee, S. E. Fisher,

E. I. Franklin, E. H. Corey, J. D. Lincoln, E. S. Horton, J. H. Horton, Henry Wexel and Harvey Clap, of Attleboro. Messrs. Bugbee and Wexel are the only new members of the board. The following were elected as officers for the year 1889; President, Dutee Wilcox; Vice-Presidents, W. R. Dutemple and J. D. Lincoln; Secretary, Marcus W. Morton; Treasurer, H. S. Dorchester. Finance Committee: E. S. Horton, N. B. Barton and R. S. Hamilton, Jr. The resignation of J. L. Sweet, as Director, was accepted, and Alfred P. Crosby, of Sweet & Crosby, of Attleboro, was elected to fill the vacancy. The following resolutions were passed:

Whereas, A resolution having been adopted by this Board of Trade April 30, 1888, to the effect that no member should pay or make allowance for express charges on orders amounting to less than \$25 net value, and

Whereas, No penalty being attached for infringement of such resolution it has been disregarded by certain members, and

Whereas, The interests of certain other members who have respected the resolution have been injured by the failure of their competitors to act in concert with them, therefore be it

Resolved, That the resolution adopted April 30, 1888, relative to the disallowance of express charges be and is hereby rescinded.

Atwood & Colwell have dissolved partnership, W. R. Colwell retiring. Both parties will sign in liquidation. W. K. Atwood will continue the business at the old stand under the firm name of Atwood & Co.

John Hogan severed his connection with S. K. Merrill & Co. on January 1, having represented them on the road during the past year.

Chas. W. Battey has severed his connection with W. R. Lane & Co. as their representative on the road, Mr. Lane having concluded to fill that position himself.

Geo. R. Plummer, late foreman for Atwood & Colwell, died on the 15th ultimo from heart disease, aged forty years.

Frank E. Capron, manufacturing jeweler, of this city, died at his residence on Sunday, January 13. Mr. Capron was born in Attleboro in 1844, and was a descendant of the famous Capron family which settled that section of Massachusetts years ago. In the seventies Mr. Capron came to this city, where he engaged in making small galvanic batteries for a New York concern, and for some months coined money. Later with H. S. Capron he formed a copartnership for the manufacture of jewelry, and although the firm's business was not large, a good and thriving industry was established. In 1881 H. S. Capron withdrew from the firm, and until his death the late Mr. Capron ran the business under the name of Capron & Co., at No. 407 Pine street.

The creditors of the late firm of J. M. Chandler & Co. in this city have received thirty per cent. in cash on their claims and a guarantee of ten per cent. in nine months with interest.* It is reported that Chandler & Co. have agreed to pay all expenses incurred by the creditors in establishing their claims through the committees appointed by the several Boards of Trade. The Providence Board represented \$20,000 worth of accounts.

The case of Wm. H. Pearson *vs.* B. L. Hall & Co., came up in the Court of Common Pleas on Saturday last, and judgment was found for Mr. Pearson in the sum of \$229.65 and costs.

The Grand Jury has found an indictment against L. H. Herrick for confiscating watches and jewelry from the establishment of S. Eastman, on Dorrance street.

R. A. Kipling, the well-known stone importer, who sailed per the French line steamer *La Bretagne* on January 5 from New York, arrived at Havre on the 13th inst. after a pleasant voyage.

Thos. F. Arnold has been detained at home by an attack of quinsy sore throat, but hopes soon to be around again.

Marcus W. Morton, Secretary of the Manufacturing Jewelers' Board of Trade, has been elected a trustee of Moshassuck Encampment of Odd Fellows.

Wm. A. Smith, refiner of precious metals, corner of Mathewson and Cove streets, has moved his works to No 144 Mathewson street.

G. H. Dean, connected with the Gorham Manufacturing Co., has been presented with a gold headed cane by a number of the employees.

Godfrey & Adams have all the orders on hand that they will be able to fill for the next month or six weeks.

M. Fitzgerald & Co. do not complain of the want of orders, but are being driven to the full capacity of their extensive works.

J. M. Dayton, late with Fred. I. Marcy & Co., now represents the firm of Watson & Newell,

Chas. S. Pine & Co.'s line of bracelets are second to none in the market and beautiful in design and finish.

Foster & Bailey are doing a large and driving business for the opening month of the new year.

Howard & Son report business better than ever with them, and expect the present year to far exceed anything in their history.

FAIRFAX.

Copyrighted 1888 by Charles A. Bucklin.

Mechanical Ocular Defects.

Their Nature, Cause, Correction and Relations to Functional Nervous Diseases.

EDITED BY C. A. BUCKLIN, A. M., M. D., NEW YORK.

[The aim of the author is to produce a clear and thoroughly practical course of instruction on the subject of "mechanical ocular defects," which is entirely void of useless technicalities and within the easy comprehension of every thinking student, without his having had any previous technical or mathematical education.]

INTRODUCTION.

CONTAINING A GENERAL OUTLINE OF SUBJECT TO BE CONSIDERED.



WHEN WE REVIEW the past history of ophthalmology, we must acknowledge that the advancements made during the last half of this century are truly marvelous. The intelligent application of the laws of optics to the correction of optical defects in the human eye appears to have been most singularly neglected. These laws were most skilfully applied in the construction of the most intricate optical instruments, still their simplest and most important application for the relief of suffering mankind is a comparatively new field of investigation.

The knowledge we have gained which enables us to relieve so much mental and physical suffering has been gained largely through the special study of physiology, mathematics and physics. It is the young, thoughtful, experimental investigator that has gone to the front in this field of medicine rather than the aged, thoughtful man of experience

The special study of this subject, like the special study of all other subjects, has enabled the young man to come to the front in his profession before age has clouded his intellect or crippled his ambition. Mechanical ocular defects are all readily explained upon an anatomical and physical basis. With the light of the present day in this field of investigation, we know positively the nature of the defect causing a given trouble, and also when capable of being remedied the necessary means to correct the defect.

Thirty-five years ago we knew comparatively little regarding this entire subject. It was not known that myopia depended upon the diameter of the eye ball being too long, and absolutely nothing was known regarding hyperopia and the short diameter of the eye ball which causes it. Cases of astigmatism were occasionally reported, but their true significance was not understood. Strabismus in all its varieties was not thoroughly understood by our greatest authors five years ago, some of whom are to-day so obstinate that they prefer to

acknowledge their inability to explain it rather than accept the rational and simple explanation of Mauthner. The subject of ocular muscles and the requirements for comfortable binocular vision were not thoroughly appreciated and understood five years ago. The fact that crossed cylindrical lenses, with their axes at any and all angles, have sphero-cylindrical equivalents sufficiently exact to prevent any eye from distinguishing the difference between them, is also an advancement not as yet acknowledged by those who suppose they are authority on this subject.

When we now consider the advancements made in so short a space of time, the simplicity of the subject as explained by physical laws and the extent to which the subject is generally understood, we must admit that in no other field of science have such triumphs been attained which are of such direct value to suffering humanity as in this one field of mechanical ocular defects.

Students shrink from the study of this special subject, believing it to be shrouded with almost unsurmountable technical difficulties. They should convince themselves that these difficulties are more imaginary than real. One requires only a slight elementary knowledge of *three* subjects and the difficulties will have been surmounted; these subjects are as follows:

First—A knowledge of some of the simpler laws of light.

Second—A thoroughly practical knowledge of the structure, action and analysis of simple lenses, their compounds and the common rules which govern their adjustment.

Third—The structure of the eye, its deformities, obscurities and the conditions which must be satisfied in the proper adjustment of *both eyes* when they are simultaneously brought into action in the binocular visual act.

My readers upon reflection must have sufficient confidence in their intellectual capacity to believe that they can master any subject about which there are only three things to learn.

The conditions necessary for acute vision are illustrated as follows: Suppose light coming from an object at twenty or more feet distant pass through a No. 2 convex lens, by holding a sheet of white paper at a little more than two inches from the lens, a clear inverted picture of the object from which the light is reflected is seen. In this illustration the lens represents the cornea and the lens of the eye; the distance between the lens and paper represents the diameter of the vitreous chamber; the paper represents the retina. The image having been distinctly cast upon the retina, a further condition necessary to acute vision is its perfect conduction to the brain, and a perfect perception by it of the impression received.

Every visual defect, therefore, depends upon a failure of one or more of the following conditions:

If the difficulty be due to a fault in the *perception* or *conduction*, then the condition is due to an organic change in the brain or optic nerve, and is known as amaurosis or amblyopia.

If from some obscurity in the refractive media of the eye the light is prevented from entering, we have an obscurity of vision. If from some faulty shape of the eye ball the image is distorted and is not cast distinctly upon the retina, we have an *error of refraction*. If the lens fails to adjust for different distances, one may have good distant vision but imperfect near vision, in which case we have an *error of accommodation*.

Errors of refraction are always due to deformities of the *eye ball*.

Errors of accommodation are always due to some disturbance in the focussing or adjusting apparatus of the eye.

Muscular defects are always caused by a faulty ocular muscle which makes it impossible or inconvenient to maintain the direction of both eyes upon an obscured object.

Amaurosis or amblyopia are always caused by a faulty perception or conduction of the visual impression.

Obscurities of vision are due to inflammatory or atrophic changes in some of the refractive media of the eye. In every case of defective vision one or more of the above five conditions must exist. The question immediately arises how are we to decide which

of these conditions is present. This is done by a systematic experimental method of exclusion, the general outline of which is as follows.

(To be Continued.)

The Marfels Watch Collection.

[From the *Deutsche Uhrmacher-Zeitung*]

Continued from page 42, January, 1889.

PART III.



MECHANISM similar to that shown in fig. 6 we find again in the so-called combination watch, fig. 12. In this watch the dial is in the same manner divided in two parts, the minutes are upon the left side and the hours upon the right. Both hands stand at rest upon XII, and so truly one over the other, that they appear as if they were only one hand. When a pressure is exerted upon the push button, the hands spring apart and show the correct time—the hand underneath points out the hour, the upper one designating the minutes, which motion produces a startling effect. When the pressure upon the button ceases, the hands return to their position of rest and remain stationary, although the watch continues to go. The construction of the mechanism producing this ingenious way of indicating time, is almost the same, only somewhat simpler than that of the watch shown in fig. 5, with the two soldiers, which point with their sabres to the time upon two quadrants. As by this watch, the center wheel is also in the combination watch. Out of the center of the movement, and upon the center wheel arbor sits movable a cannon with pinion, upon the under side of which is located the snail for the minutes. In the center of the upper movement plate is a stationary pin, upon which revolves freely the cannon carrying the minute hand. The pinion of the cannon stands in depth with a

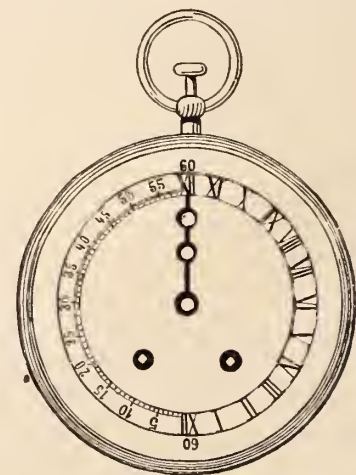

FIG. 12.

rack, which, by the operation of a spring, falls with its projecting end upon the minute snail, whenever it is unlocked by pressing down the push button. Now, according as the rack abuts closer to or farther from the center of the snail, the cannon standing in depth with it, together with the minute hand sitting upon it, is carried around to the left to the time corresponding to the position of the snail. The motion of the hour hand is effected in the same manner. The above-mentioned pinion upon the center wheel arbor stands in depth with the hour wheel revolving around a motion work pin; the hour wheel, beside this, stands also in depth with another pinion, which moves freely upon the cannon and carries the hour hand. The latter pinion is carried around to the right by the hour rack standing in depth with it, and as the latter, in its unlocking, butts with its projecting end upon the hour snail fastened to the hour wheel, the hour hand will naturally fly to the hour. The two racks are simul-

taneously unlocked by the pressure upon the push button, and, consequently, the motion of the two hands takes place at the same time. When the pressure ceases, all the parts are, by the operation of a strong spring, brought back to their position of rest. From this short detail, the action of the medium will be readily understood.

Richly and fancifully ornamented is the work shown in fig. 13, which is contained in a very handsome case embellished with



FIG. 13.

soldered-on gold ornaments à quatre couleurs (in four colors). As will be seen from the cut, the back plate is in form of a serpent, in the convolutions of which are the holes for the pillars. The regulator stands in the center of a star-shaped balance bridge, and movable around its center. The value of the movement is still increased by the very peculiar, although little impracticable escapement with two balances, one of which vibrates under the bridge shown in the cut, while the other moves in the interior of the movement. The former balance is provided with a balance spring, and toothed around its circumference. These teeth seize into a pinion, which is situated on the staff of the second balance, and therefore actuate this at the same time in a reverse direction. The performance of the two balances may be highly interesting for the layman, although it is entirely devoid of value for the practical watchmaker. We therefore refrain from entering into a detailed description of the escapement, and give simply a few explanations. The part of the escapement to which the principal balance is fastened consists of a

FIG. 14.



FIG. 15.

fairly heavy cylindrical arbor, better than half cut through at the place where the escape wheel passes. The remaining part of the arbor is rounded according to the shape of cylinder lips, and the wedge-shaped teeth of the scape wheel, which resembles a cylinder escape wheel, effect the lifting in a fairly primitive manner on these lips.

While we were considering the laborious work the maker has spent on this watch, our attention was attracted to an excellently-worked

and very well preserved egg watch movement, made in about 1650. In order to give our readers an approximate, even if superficial, view of it, we show the dial in fig. 14, and the back plate in fig. 15. The watch shows upon two silver rings the hours and date; furthermore, in three cut-outs in the dial, the moon phases, the week day, with allegorical figures, and the months, together with the zodiac. Simply the dial, of itself, is worth being considered a masterpiece, as it is worked with a high degree of taste. The lower part, which carries the pillars and the calendarium, is of bronze, and the upper externally visible part of silver, engraved most artistically, and fire gilt. Astonishing, indeed, is the very simple contrivance for moving the calendarium, used by the old master. The whole is actuated by a six leaf pinion

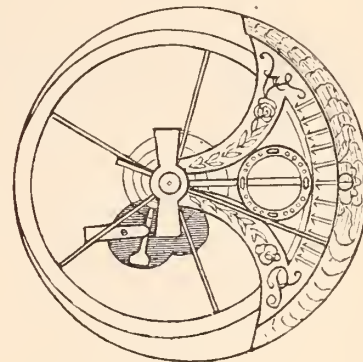

FIG. 16.

upon the pivot of the fusee, and, in spite of its simplicity, works with perfect precision, so that errors can never occur.

The movement itself in all its parts is worked with the same degree of skill, and we would call special attention to the delicately-worked balance bridge upon the back plate, shown in fig. 15. Very remarkable is also the engraving upon this plate, it being so delicately executed that it appears as if breathed on. In one word, this piece may be considered an ornament of the collection.

Surpassing all its fellows, both in size and thickness (the movement is more than two centimeters high), our attention is attracted by an old verge watch, showing only the hours, and made in the seventeenth century by Lazare Arland, in Geneva. Its characteristic

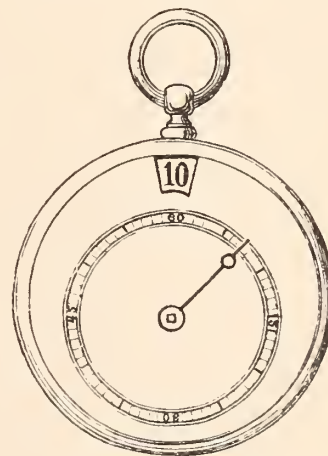

FIG. 17.

dial, its admirable balance bridge, executed in the richest style of the Renaissance, and almost as large as the plate, its exceedingly artistic interior ornamentation, would at once secure for this watch a prominent place in any collection. The principal distinguishing feature of this watch, however, and one interesting to the watchmaker, is the very peculiar concentric winding mechanism. The center wheel stands eccentric, to one side, at the place where the center staff stands generally. Under the dial plate in the center of the plate, and freely revolvable upon it, is a strong steel wheel, which is riveted on the lower end of a fairly heavy arbor, which forms the winding post. This is provided above with a square, and under the wheel with a short pivot, moving in the plate, and serving as fulcrum to the winding arbor together with wheel. A bridge,

through which passes the winding post projecting far beyond the dial, is, for greater security, located above the wheel. This wheel stands in depth with a second equally large steel wheel fastened upon the prolonged fusee pivot whereby the progressive motion of the first wheel is transported upon the fusee, and the winding of the watch from the center is thereby effected in a simple manner. The hour cannon here revolves around the winding arbor, as it does ordinarily around the cannon pinion, while the hour wheel receives its regular motion by means of wheels from the laterally lying center wheel. The question whether the winding arrangement of this watch may not be considered as the first beginning of the present stem-winding will naturally prompt itself to the intelligent watchmaker.

Before we continue the description of specimens of this collection



FIG. 18.

which are distinguished by their ingenious construction of the movement, let us throw a hasty glance at a fairly flat watch with comma virguled escapement, made in 1780. This watch is remarkable chiefly by having all its teeth and depths of evolvent rounding. The trouble expended by the maker upon this peculiarity is truly astonishing, but the result obtained therewith must doubtless not have complied with his expectations, although the evolvent depthing, theoretically considered, is the most correct, as by power of the properties of this curve, the two acting radii of the power and of the resistance are always equal to the pitch radii; the motion, therefore, always occurs with equal pressure, without change or loss of power. In spite of these preferable properties of the evolvent depthing, it is useful only in large clocks, as there are no means of executing the tooth curves of the wheels and pinions with precision, on a small scale, and this has been the experience of our experimentalizing master.

Attracted by the powerful vibrations of an imposing balance, four centimeters large, we pause before an anchor watch of older construction, made by Robert & Courvoisier. We give a posterior view of it in fig. 16. The five-armed, clearly-made balance is about of the same size as the movement, and it appears among its fellows like a giant among pigmies. Each of its vibrations marks one second. The movement, worked very carefully in all its parts, is in its construction similar to a verge watch, except its escapement, which is a kind of pin escapement, as occasionally still found in older mantle clocks. The flat escape wheel is, in place of teeth, provided with twelve upright round pins, which gear into a flat anchor scaping over three pins, with full lifting and entire repose. The short fork sitting upon the pallet staff, and of the same size as the anchor, describes an arc of 45 degrees, and has a notch $1\frac{1}{2}$ millimeters broad. The impulse pin in the roller upon the balance staff is of the same breadth. As a curiosity may be mentioned that the balance staff of this old anchor watch, beside the impulse roller, has already a second so-called safety roller, and is, therefore, a double roller escapement. Upon the long pivot of the fourth wheel, standing in the center of the movement, sits the large second-hand, and this timepiece is, therefore, also an independent seconds watch. It may safely be accepted that the makers of the watch were interested principally in the latter feature in other respects, because, it stands to reason that such a watch, by reason of its large balance and slow vibrations, can have rendered but imperfect services as pocket timepiece.

In the category of the watch with springing hours, described and shown in figs. 3 and 4, also pertains that of fig. 17, a verge watch

belonging to the commencement of this century, which shows the minutes in the ordinary manner by a hand upon the dial, while the hour is visible through a cut out in the latter.

The fairly flat, very carefully excavated movement of this watch, the maker of which has not left his name on it, has apparently been made in Geneva. The hours are located upon a silver disc moving underneath the dial; the disc is actuated by the mechanism shown in fig. 18, and springs one figure every hour, so soon as the minute hand has arrived at full 60.

Upon the arbor of the center wheel, standing out of the center, sits, in place of the cannon pinion, a smooth cannon, movable with friction, carrying upon the square of the upper end the minute hand. The lower end of the cannon is provided with a projection, by which the mechanism effecting the propulsion of the hour disc is every hour actuated in the following manner:—When the aforementioned projection in its hourly revolution touches a tooth of the star, *a*, this is pushed forward, and the elastic jumper, *c*, is thereby also gradually raised until it arrives upon the point of the tooth, from which it slides down into the next following tooth space of the star, *a*. On the other hand, as the teeth of the star, *a*, operate upon the star, *b*, sitting upon the hour disc, the latter is naturally moved forward by a bound, and thereby also the hour disc. In consequence of the operation of the just-described mechanism, a new figure will every hour appear in the cut-out. So as to show the operation of the mechanism more plainly, the stars, *a* and *b*, are in the cuts shown above the hour disc, although, in reality, they lie underneath it.

That the old watchmakers entertained the idea of constructing watches showing two kinds of time, local as well as universal, is shown by the verge watch, shown in fig. 19, dating to the end of the last century. The maker of this watch went even still further by employing the decimal system for the indication of the astronomical time, and dividing the day into ten hours, each of which into 100 minutes.

For the purpose of showing this double time, the watch has two dials, one upon the front and one upon the back, of which the dial showing the local time is divided in the ordinary manner from I to XII, while the other, intended for universal time, is divided into ten

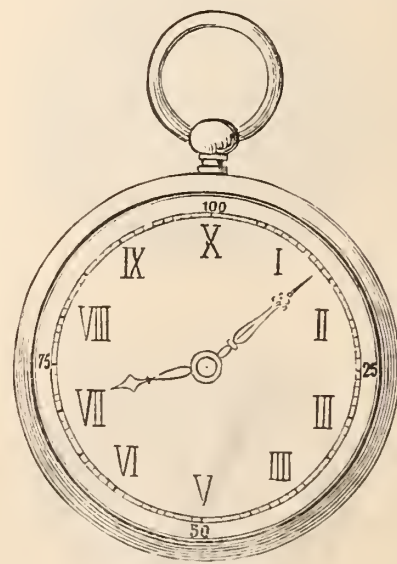

FIG. 19.

hours, which correspond to the usual twenty-four hours, as shown in fig. 19. It is interesting to see how adroitly the old master managed to solve the proposition, repeatedly revived in modern times, "in order to indicate universal time, to divide the day, beginning at noon, into ten hours, each of which into 100 minutes, and, again, each of these into 100 seconds."

The motion works of this watch are arranged in the following manner:—Through the perforated center-wheel pinion passes revolving with friction, a staff, having upon each of the two projecting ends (therefore upon each side of the watch) mounted a cannon

pinion. The motion work of the one side, which indicates the local time, has the calculation for the usual twelve hours, each of which of sixty minutes, while that of the other side, intended for the indication of universal time, has an entirely different calculation. In this motion work the cannon sitting upon the center staff has a fifteen-leaf pinion, which depths into a wheel of forty-five teeth revolving around a stop screw, which, by reason of its number of teeth, is revolved once in three hours. This wheel depths into a second wheel of the same size and number of teeth, upon which is fastened the minute wheel. The latter has thirty teeth, and gears into the actual cannon pinion, which revolves freely upon the first-mentioned cannon upon the center staff; it has twenty-four teeth, and carries the minute hand. The minute wheel has an eight-leaf pinion, which depths into the hour wheel with sixty-four teeth and revolves it.

The detailed calculation shows that by this motion work the minute hand revolves in one day—twenty-four ordinary hours—only ten times, and the hour hand once. Each $\frac{1}{10}$ decimal hour of the universal time indicated by the hand, therefore, corresponds precisely to the duration of two and two-fifths hours, or 144 minutes of the local time shown by the ordinary motion work.

Of the several specimens of repeating watches with musical work, we will notice only one, which is especially distinguished by its very excellent style of execution and tuneful music.

The construction of such watches is doubtless known to older



FIG. 20.

watchmakers, especially those from the continent; less so, however, to the younger generation, as this style of watches is but seldom encountered at present. We therefore add a cut, fig. 20, of one, for the inspection of those of our readers who have not had the opportunity of examining the real article. The cut shows such a watch without and underneath the dial. The watch plays at the expiration of every hour, as soon as the minute hand has arrived at XII, and repeats the piece of music as often as desired by unlocking the stopping arrangement.

The pins raising the gongs do not, as in a musical box, lie around a cylinder, but upon a flat wheel. As the entire musical mechanism is plainly shown in the figure, no further explanations are considered necessary.

Another interesting piece of the collection is an eight-day verge watch, executed with extreme care. It has a remarkably small balance. On the other hand, the watch has a monstrously large barrel, with a very long mainspring. In order to mete out the tension of the latter for an eight-day watch, the fusee is constructed accordingly; but, in spite of all this, and in spite of the really careful and excellent work bestowed upon the watch, we would not like to guarantee its uniform rate with one winding for eight days.

To the pieces of the collection remarkable for their mechanism

also belong four alarm watches, all of them of the seventeenth and eighteenth centuries, part of them with delicately perforated cases. As the interior construction of alarm watches is universally known, we omit the description, as we intend to speak of them again, when treating of the artistic embellishment of cases, dials, etc. In this particular, so great a fund of material lies before us, that the reader will be surprised at the great variety embraced in the Marfels collection.

(To be Continued.)



[THE CIRCULAR is not responsible for the opinions or statements of contributors, but is willing to accord space to all who desire to write on subjects of interest to the jewelry trade. All communications must be accompanied by a responsible name as a guarantee of good faith. No attention will be paid to anonymous letters. Correspondence solicited.]

MR. MARFELS SENDS HIS COMPLIMENTS.

Frankfort-on-Main, Germany, Dec. 24, 1888.

To the Editor of the Jewelers' Circular:

With great pleasure I have read your first article of my watch collection, and hasten to send you herewith a just appeared book of the same, with the request to accept it as a present for your library.

You would mightily oblige me, sir, if you would send me of the last number of your review (No. 11) 3 or 6 copies, as well as of every new number that contains the continuation of my collection.

You will perceive that the first egg watch of the book is not yet described by the *Deutsche Uhrmacher Zeitung*, because it is only a few weeks ago I had the chance to buy it. As it is a first-rate watch I should counsel you to describe it and show it to your readers in good wood engravings. For this purpose I give you at the end of these lines a description of it in German that can easily be translated by your translator, of whom I admire the knowledge of our language.

Please do take notice that my name is written Marfels *not* Marsfels. It must thus be written: "The *Marfels* Watch Collection."

Yours truly,
CHARLES MARFELS,
Groper Hasenpfad 56,
Frankfort-on-Main, Germany.

Address for despatches Charles Marfels, Frankfort-on-Main.

A FRIEND OF TECHNICAL EDUCATION.

Providence, January 11, 1889.

To the Editor of the Jewelers' Circular:

Will you kindly send us via our New York office, half a dozen copies of your issue which contains the description of our new works. We should also like to have a few copies of the number containing the editorial article in relation to John Ward Stimson's institute for artist-artisans.

The writer, Mr. Howard, Sr., takes a deep interest in Mr. Stimson's work, and, in his opinion, the manufacturing jewelry trade ought to appreciate the kindness and liberality that prompted you to say such kind words for Mr. Stimson's enterprise.

Yours truly,
HOWARD & SON.

FROM OUR HELPERS.

Oswego, N. Y., January 16, 1889.

To the Editor of the Jewelers' Circular:

In response to your very kind circular, we would be pleased to receive the advance sheets of the articles titled "A Lady's Rambles Among the Jewelers," and feel assured that these articles will be of

mutual benefit to the jewelry trade. Can you suggest how best to introduce them to the public, and do you think it advisable to pay for their introduction, say some nominal sum, rather than allow them to remain unprinted?

We heartily endorse the idea and realize what great influence these articles have on the public. They certainly create an interest as well as oftentimes suggest the purchasing of trinkets which meet the caprices of an uncertain public. We would be pleased to hear further from you on the subject.

Yours very sincerely,
JULES WENDELL & SON.

UNSOLICITED TESTIMONIALS.

Preston, England, December 18, 1888.

To the Editor of the Jewelers' Circular:

I am short five numbers of your journal, and will gladly pay twice the published price if you can send them. I want them to fill up gaps.

J. J. BRAMWELL.

Trenton, N. J., January 8, 1889.

To the Editor of the Jewelers' Circular:

Be kind enough to mail me early each month. Send in first ones finished. Your paper has improved the past three years.

Yours truly, GEORGE F. APPLGATE.

Mason City, Iowa, January 14, 1889.

To the Editor of the Jewelers' Circular:

It gives me great pleasure to renew my subscription to THE CIRCULAR for the twentieth time.

CHAS. E. MANN.

North Kingston, N. S., January 11, 1889.

To the Editor of the Jewelers' Circular:

Enclosed please find two dollars, for which you will please send to my address THE JEWELERS' CIRCULAR. I received a sample copy of THE CIRCULAR, December number, and was much pleased with it, although it was a long time in reaching me on account of being addressed to Malvern Square instead of Kingston:

Yours truly, W. W. NEILY.

Wamego, Kansas, January 12, 1889.

To the Editor of the Jewelers' Circular:

Please find enclosed my \$2 for the ensuing year, and let me say that I think it is one of the best investments I make during the year.

Yours truly, W. S. LYDECKER.

South Norwalk, Conn., January 9, 1889.

To the Editor of the Jewelers' Circular:

I enclose check for \$2 to renew my subscription to your very valuable paper for 1889. Wishing you a happy New Year, I remain,

Yours very truly, H. B. HOYT.

St. Paul, Minn., Jan. 19, 1889.

To the Editor of the Jewelers' Circular:

Enclosed please find two dollars for my annual subscription to THE CIRCULAR. After reading it for the past seventeen years, and having every volume bound, I find it a library in itself, from which I can always find something useful, entertaining and profitable.

Adding my sincere condolence for the past heavy blows the editorial corps has sustained,

I am very truly yours,

F. M. FINCH,

"The Down Town Jeweler."

Seneca Falls, N. Y., December 7th, 1888.

To the Editor of the Jewelers' Circular:

Please to find enclosed \$2.00 for the renewal of my subscription

to THE CIRCULAR. I can truthfully say, after two years of practical study of THE JEWELERS' CIRCULAR, that it stands without a rival as an assistant to the progressive workman at the bench. It should be in the hands of every workman.

L. H. CARY.

Brandon, Manitoba, December, 5th, 1888.

To the Editor of The Jewelers' Circular:

Am better pleased than ever with THE CIRCULAR, so kindly continue it for another year.

A. G. HEPINSTALL.

Louisville, Ky., December 29th, 1888.

To the Editor of the Jewelers' Circular:

Enclosed find check for \$2.00 in renewal of our subscription to THE CIRCULAR. With best wishes for the continued prosperity of THE CIRCULAR, we remain

Yours truly,

C. FLETCHER BENNETT,

By Henry F. Bennett.

Connellsville, Pa., November 3, 1888.

To the Editor of the Jewelers' Circular:

On my arrival home from California, I find that my subscription for THE JEWELERS' CIRCULAR had run out, and as I, or the firms that I have belonged to, have taken it for the past ten years, it has got to be almost a fixture in our office, and we do not feel as though we could get along without it. It has always been a marvel to me how you could give so much for so little money.

HYATT & CASE,

Per C. M. Hyatt.

Columbus, Ga., January 10, 1889.

To the Editor of the Jewelers' Circular:

Enclosed please find P. O. order for \$2, subscription for the year '89. Would state that THE JEWELERS' CIRCULAR forms a very valuable part of my library, consisting up to date of twelve volumes, starting with Vol. VII. in '76. When neatly and substantially bound—which can be done for about \$1 (devoid of advertising matter) per volume, THE CIRCULAR makes a very handy book of reference and information, of about one and one-eighth inch in thickness.

Would suggest that you call the attention of your subscribers to this matter again, as a great deal of *now* waste matter can be turned into a systematically arranged collection of interesting matter.

Respectfully,

C. SCHOMBERG.

Obituary.

WILLIAM HOWKINS.

William Howkins, once prominent as a member of the firm of Carter, Howkins & Dodd, died of pneumonia at Newark, N. J., on January 1st, in the 65th year of his age.

He was born in Birmingham, England, and came to America at four years of age. When thirteen years old he left school to follow the mechanical bent of his genius, and entered the shop of George H. Dowling as an apprentice. After serving the full term of his apprenticeship, he started for California when the gold fever broke out in 1849, and opened an assay office, but returned to the East the following year on account of ill-health.

In 1851 he entered the employ of Carter, Green, & Doremus, of Newark. The exceptional mechanical abilities which he possessed led to his speedy advancement, and he became foreman of their shop, and, in 1859, was given a partnership interest, the firm style being changed to Carter, Hale & Co., and subsequently, to Carter, Howkins & Dodd. Later Mr. Dodd retired, and Mr. Sloan's name

appeared in his stead. Mr. Howkins also retired in 1881, and the firm of Carter, Sloan & Co. came into existence. Since his retirement Mr. Howkins has devoted most of his time to stock-raising on his farm near Newark. He leaves four sons, two of whom are engaged in the jewelry business.

CHARLES VAN DER WOERD.

Charles Van der Woerd, one of the most noted inventors in the line of watch machinery, died at Hackett, California, whither he had gone in search of health, on Monday, December 31st, aged 68 years. He was a native of Holland, having been born at Leyden, October 6, 1821. His father was a manufacturer of telescopes and electrical instruments, and the young man spent his early life in his father's employ. Finding the Old World a little slow for one of his progressive ideas, he came to America in 1844. His first situation was in the machine shop of Seth Adams, in South Boston, Massachusetts. He remained there until 1853, and then took a position with Alvin Clark, the telescope maker, of Cambridge, which he held until he entered the machine shop of the watch factory at Waltham, in 1857. When the Nashua Company started in 1859 he was among the number who went there to establish the new enterprise. He was first employed as a machinist, and afterwards took charge of the train department of the factory. It was while here that he invented the epicycloidal machine, its purpose being to grind circles of epicycloidal form on cutters for wheel and pinion teeth. Previous to his invention the form of the cutter was determined by the eye, which made absolute precision an impossibility. By Mr. Woerd's process of grinding the cutters, the teeth of the train are now made mathematically correct. Mr. Woerd returned to Waltham when the Nashua Company was sold and removed there. He next distinguished himself by making some improvements in jewel-making lathes, for which the company, as a token of merit, presented him with a purse of \$500 and a gold watch. He was soon after made assistant superintendent of the Nashua department, of which, in 1864, he took entire charge. Soon after this he produced his automatic pinion cutter. He also invented many other labor-saving machines and devices of more or less value, and endeavored to bring up the standard of the watches produced in the Nashua department. Prominent among these improvements was the rack and pinion gauge, for accurate measurement, and which came into general use in the factory. He also did much toward perfecting the process of hardening and tempering hairsprings. But probably what distinguished Mr. Woerd most in the horological world was the automatic screw machine which he invented for making watch screws. To show what the machine does, we will describe briefly the usual method of making screws. An ordinary lathe with a double slide rest carries two tools, one to turn the screw down for the thread part, the other to cut the screw off when threaded. This lathe has a three spindle tail stock. One spindle carries a stock that gauges the length of the screw, another a die to cut the thread, and the third a cutter to form the screw point. In addition to this the head is then slotted by another process. Mr. Woerd's automatic machine does the work all at once, making a screw complete from the wire. One girl will attend to several, each turning out 3,500 screws per day.

In 1875 Mr. Woerd was made superintendent of the entire Waltham factory, which position he held until the summer of 1882, when he severed his connection with the company, and after spending a few months in Europe, returned to Waltham, and entered into business relations with Messrs. Nutting Bros., of the United States Watch Company and the Waltham Watch Tool Company.

The new firm pushed forward in the manufacture of tools, making a specialty of Mr. Woerd's patent automatic machinery.

Mr. Woerd, however, soon conceived the idea of enlarging the plant to the proportions of a watch factory, and as his partners were agreeable to it, work was commenced on the necessary tools and machinery. A capitalist was found in the person of Mr. E. C.

Hammer, of Boston, and an organized company was the result in 1884, called "The United States Watch Company," of Waltham, with a capital of \$50,000.

The watch the company started to make was designed by Mr. Woerd, and was a sixteen size, three-quarter plate, pillar movement, in three grades. It had a very wide mainspring barrel, and to make room for the center wheel to run over the barrel, the top plate, which was thinner than most watches have, was swedged up in the center similar to the cap of a full plate English watch is swedged up to make room for the balance wheel. It was dubbed the Dome Watch at the factory.

The train, which was first slow and then changed to quick, had round bottom teeth to the wheels. The fork was made of aluminum bronze, with a circular slot and square ruby pin. The balances at first were gold, but when the train was changed expansion balances were used. The stem wind, which was one of Mr. Woerd's patents, was certainly an admirable one in many respects. It was a yoke with a loose intermediate stem winding wheel, and was pendant setting. The movement required a special case, which, of course, made it unpopular with the retail trade, and it was dropped in November, 1887, at which time Mr. Woerd severed his connection with the company. The remainder of Mr. Woerd's life was uneventful, and his health having failed, he sought relief in travel on the Pacific coast, where his death occurred. The body was brought East for interment.

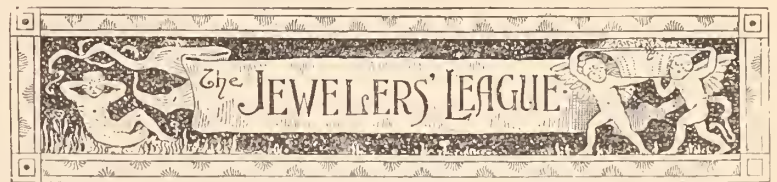

TWELFTH ANNUAL MEETING.—OFFICIAL REPORTS.—CHANGES IN THE BY-LAWS.



THE TWELFTH annual meeting of the Jewelers' League was held at the Masonic Temple, corner of 23d street and Sixth avenue, on Tuesday evening, January 15, and was well attended. The meeting was opened by President Hayes in the following address:

GENTLEMEN—We have reached the twelfth milestone in our prosperous journey. The path has been one both of toil and pleasure, strewn not with flowers of indolence, but with memories of work well done, of great good accomplished. Our condition to-day is one of confidence and strength—a strength far greater than at any prior period of our history; for, although the number of members may have slightly diminished, the continued prompt payment of every obligation by the present membership evidences the ability to meet the requirements of duties devolved upon us. We must all fully understand that insurance of any kind cannot be furnished at less than cost, and we have not yet arrived at a point where our annual assessments will pay the increased cost of increasing age, but as this fact must now be fully appreciated by every member there is no doubt of our continued ability to meet the burdens we have mutually assumed.

It must be evident that the measure passed at our last annual meeting for increasing our contingent fund was most wise for several reasons. It gives stability to the institution and binding force to the membership. In times of unusual mortality, which is likely to occur occasionally in any company, it prevents too large a percentage of lapse, and men will not hastily and unadvisedly abandon an association which has financial strength to meet an emergency, and in whose existence they have a pecuniary as well as an insurable interest. If experience should prove that we are not accumulating a sufficient reserve for providing in later years the increasing cost consequent upon the increasing age of our membership, we must not hesitate to throw around our League the safeguards required to meet these demands and contribute means as shall be adequate to the needs, remembering at all times that we are pledged to each other to furnish insurance at cost.

But there is a feature in our company as great as the financial one, viz., the bond of brotherhood. Doubtless many of you would have cheerfully contributed the amounts already paid if there were no consequent advantages. You all feel the intense satisfaction of having provided in many—yes, in most—cases of the

decease of members for the comfort of dependent families, thus relieved from the grim visage of total penury and want. Hardships relieved and joy contributed are incentives worthy the impulses of generous hearts. This feature of fellowship has been declared but recently by a prominent officer in a level premium life company to be a source of cohesive strength to our association, promising a length of life and a stability warranting sincerest confidence. Yet this very source of strength will be weakened if each and every member does not determine to enlarge the work and increase the membership. Would it be much of an effort for all our members to obtain at least one additional member within the year? Have we not enough at stake to urge us to perform this slight duty—slight to an individual, great in its results to our consolidated interests?

The changes proposed in the constitution, approved by the Executive Committee, are merely technical, intended to facilitate the working of the business to the advantage of the beneficiaries. To this remark there is the one exception—in the new feature proposed of having six advisory members of the Executive Committee who shall be men likely to meet our distant members and furnish them every information concerning our association. There is not a feature of our institution or a particle of its business that may not and should not be known by every one of our members. This fact is appreciated and constantly expressed by the Executive Committee, so that they, more than any others, would be gratified to have you pass this provision. Permit me here, at the risk of an annual and perhaps monotonous repetition, to express my gratification, as well as the obligation of our members, to the Executive Committee for their continued diligence and devotion to their duty and to our advantage.

You should know of their attention, how it is bestowed at a sacrifice of time and at a pecuniary personal expense. The latter item actually adds to every member of the committee a cost exceeding 25 per cent. of that borne by the other members of the League. If this can be considered of the slightest personal advantage there will be no hesitation on their part to have it conferred upon other men; but we are all aware of the value of experience, and certainly will hesitate before committing our interests to untried hands.

Although superfluous, I will not omit to again assert the debt of obligation due our Secretary and Treasurer for the unwearied attention, thorough ability and comprehensive care devoted to our interests. Money does not begin to express the measure of reciprocation for the care and thought unremittingly given to the responsibilities of his trust.

And now, gentlemen, with these discursive remarks, and without further detaining you, we will proceed to the business before us.

Secretary Sexton then submitted his annual report, which was unanimously adopted, as follows:

Report of Secretary and Treasurer.

Amount paid to beneficiaries to 1888.....	\$505,962.70
Amount paid to beneficiaries during 1888.....	125,000.00
<hr/>	
Total paid beneficiaries	\$630,962.70
Membership January 15, 1888.....	2,318
Members admitted during 1888.....	58
<hr/>	
Members dead, dropped and resigned.....	143
<hr/>	
Membership at date.....	2,733
The entire current expense of administering the affairs of the League	
For 1886 was.....	\$9,327.00
For 1887 was.....	7,151.19
For 1888 was.....	6,841.87

This is an average of less than 5 per cent. per annum on the receipts of the League.

It means insurance at cost and a reserve fund of \$80,000.

The undersigned have examined the accounts and assets of the Jewelers' League and find them correctly set forth in the annual report herewith submitted by the Secretary and Treasurer.

C. C. CHAMPENOIS, } Examining
 JACOB STRAUSS, } Finance
 L. T. BEST, } Committee.

New York, January 15, 1889.

	General Fund.	Reserve Fund.
Amount on hand January 16, 1888.....	\$2,500.00	\$5,000.00
<hr/>		
RECEIPTS.		
Fifty-eight members' initiation fees, at \$3.....	174.00	
Fifty-eight members' first assessments, at \$2.....		116.00
Surplus assessment of six members, at 50 cents.....	3.00	
Surplus assessment of six members, at \$1.....	6.00	
Surplus assessment of seven members, at \$2.....	14.00	
Amount from reinstatements.....	2,318.50	
Interest on deposit at Union Trust Company.....	74.32	
Interest on contingent fund.....	1,915.00	
Interest on permanent fund.....	335.00	
Interest on permanent fund, \$50 4 per cent. coupon bond.....	1.00	
Assessments Nos. 110 to 114.....		27,592.50

Assessments Nos. 115 and 116.....	10,946.00
Assessments Nos. 117 to 120.....	21,704.00
Assessments Nos. 121 to 123.....	16,032.00
Assessments Nos. 124 to 126.....	15,414.50
Assessments Nos. 127 and 128.....	10,833.00
Assessments Nos. 129 to 133.....	25,225.00
Amounts from quarterly dues	8,053.00

Total amounts to the credit of the Treasury. \$15,393.82 \$132,863.00

DISBURSEMENTS.

Beneficiary of Albert Ballowitz, Chicago, Ill.; H. S. Bodge, New York City; W. E. Carpenter, St. Paul, Minn.; W. R. Fuller, Mount Vernon, N. Y.; Charles H. Eppstein, Brooklyn, N. Y.; Charles H. Freeman, North Attleboro, Mass.; Francis T. Bemis, Boston, Mass.; J. J. O'Brien, New York, N. Y.; George A. Eaton, New York, N. Y.; Frank N. Reeve, Newark, N. J.; John Haggerty, Providence, R. I.; Theodore Stunz, Baltimore, Md.; George S. Webb, Brooklyn, N. Y.; George W. Simons, Jr., Philadelphia, Pa.; John E. Hill, Biddeford, Me.; C. H. Miller, New York, N. Y.; R. C. Stiddig, New York, N. Y.; A. H. Fisher, Springfield, Ill.; George H. Carter, South Pittsburgh, Pa.; C. S. Dovey, Philadelphia, Pa.; E. E. Wadsworth, New York, N. Y.; G. H. Gardiner, New York, N. Y.; James Steffeck, Chicago, Ill.; John Rose, Bay City, Mich.; Rufus C. Justus, Baltimore, Md. Commission of Secretary and Treasurer, 3½ per cent. on \$127,862. Amount of benefit fund, \$3,387.80.

MISCELLANEOUS DISBURSEMENTS.

Books, stationery and printing	\$851.29		
Postage and rent of P. F. box 3444.....	563.50		
Rent of office.....	400.00		
Gas, ice and office expenses.....	105.48		
Services of counsel and attorney, etc.....	245.00		
Fee of examining surgeon.....	10.50		
Rent of box in Safe Deposit Company.....	10.00		
Rent of Hall for annual meetings, 1888 and 1889	50.00		
Rebate on initiation fees.....	24.00		
Protected checks in default of assessments.....	18.86		
Commission of Secretary and Treasurer, 3½ per cent. on \$2,515.50.....	88.04	2,366.67	13,027.15
<hr/>			
Uninvested balance of 1888.....			\$16,414.05
<hr/>			
			1,351.86
<hr/>			
			\$17,766.81

In addition to the above balance there is under the supervision of the Board of Trustees of the League in the safe deposit vaults of the Nassau Bank—

\$500 New York City 6 per cent. registered bonds and 3,000 New York County 6 per cent. registered bonds, which cost	\$4,733.82
\$2,500 New York City 5 per cent. registered bonds, which cost.....	3,272.94
\$10,000 New York City 6 per cent. registered bonds, which cost.....	13,647.95
\$10,000 New York City 7 per cent. registered bonds, which cost.....	13,145.89

Also, temporarily on deposit with the Atlantic Trust Company, awaiting re-investment and earning 2½ per cent. interest. 26,510.00
 This latter amount being the sum realized from the sale of \$20,550 of Government bonds, at a profit to the League of \$1,493.75.
 Accrued interest on this \$26,510

	158.27	61,46.07
Total cash assets of the Jewelers' League of the City of New York.....		\$79,235.68

WM. L. SEXTON,
 Secretary and Treasurer

George R. Howe next read the report of the Executive Committee.

MR. PRESIDENT AND GENTLEMEN—Your Executive Committee take pleasure in submitting their twelfth annual report, and again congratulate our membership on the prosperity of the Jewelers' League. In order that our financial standing may be plain to every member, the report of the Secretary and Treasurer has been printed as usual. Please give it the careful consideration it deserves.

During the earlier years of our organization there were many who doubted whether we could last ten years. We have, therefore, not only outlived the time thus allotted us, but your committee, we believe, are on a firmer basis to-night than ever before in our history, although our numbers are fewer than for several years past. Many members who joined originally were unable to carry \$5,000 insurance, and as a consequence have been obliged to drop out, but comparison with other and similar organizations will show that the percentage of members thus lost to the League has been as low proportionately as has been our death rate. Another fact that deserves consideration is that each member who has dropped has received full value for every dollar he may have paid into our treasury, because no one of us pays more than the simple cost of each year's insurance, if we even do that. Our present members, or at least a large majority of them, are probably able to carry \$5,000 insurance, while our accessions outnumber our losses by death, so that there is every prospect of a steady and safe increase from this time. However much sympathy we may feel for individual members who are obliged to drop out from our number, it is essential that we each feel that we are associated with a

body of men *honorable* not only, but *able* to meet their obligations promptly, because upon this double foundation rests the perpetuity of our League.

Your committee are glad to know that the suggestions of the past two annual reports, advising members to lay aside regularly the average amount necessary to meet our yearly assessments, are being acted upon, in some cases at least, and would commend the example of these prudent members as worthy of imitation. They are thus able to meet a heavy assessment at any time without inconvenience.

Your committee also wish to impress upon you the importance of paying assessments promptly *for your own sakes*. To be dropped from the roll and remain so for weeks after your money is in the hands of the Treasurer, because our constitution makes re-instatement impossible until the next meeting of the Executive Committee, and even then optional with them, may leave your beneficiaries unprovided for when you are gone and solely through your own lack of promptness. Investigation convinces your committee that in the majority of cases the cause of delay is carelessness and not inability.

In closing, your committee has one request to make, viz.: That as no life insurance company of any kind can live without constant accessories, every member will interest himself in this direction. As our League is entirely mutual in character, and as we each have an equal interest in its success, it is the duty of each member to do what he can to promote the common good. We fear that many of us have grown careless in this regard. Your committee confidently expect to see important results from this appeal, because of your hearty co-operation and active interest in all the past, which we wish gratefully to acknowledge at this time.

The faithful and efficient work of our Secretary and his associates, of our board of examining surgeons and the courtesy shown us and interest taken in our welfare by the trade journals, have contributed to our success. It is with pleasure that your committee call your attention to them all, and hereby extend to each of them severally its thanks.

The election of officers followed, and resulted in the re-election of President Hayes and Secretary Sexton. Both gentlemen responded in a few well-chosen remarks. The Secretary said, after the applause that greeted him had subsided:

GENTLEMEN—If the President of this association thinks that the fact of his re-election is getting to be an old story, I am sure I certainly can do so with as great a degree of truth, because it has come to be an old story. I cannot but be grateful to you. I have told you that before, and I mean it sincerely.

It shows not only confidence in the office as it is administered now, but it shows confidence in the present and the future of the League. When the President said, and emphasized this fact, that the association is one of the best, he said what was actually true; and there are gentlemen on this platform now with whom I conversed recently, who can bear him out on this point. I allude to the President of one of the leading insurance companies in this city—a company that stands very high in our community—who bears witness to the fact that the Jewelers' League, as it is now formed—a purely mutual trade organization—is one of the best organizations of its kind in the country.

Once in a while a person expresses an opinion very tersely, and on the bottom of one of the assessment slips a member says: "I have paid \$50 this year for \$5,000 insurance; that is, just 1 per cent. for good insurance. I am willing to pay 2 per cent. per annum and think I am getting cheap insurance."

There is only one weak spot in our financial report, as it is given before you, and that is the decrease in our membership. It is not dangerous, but it is one that we must take steps to guard against in the future. It will not do to let our membership run down numerically. We have a large reserve fund, but we do not want to draw on it very soon, as we will have to do if we allow our membership to decrease in numbers. It is not necessary. There are certainly among the fifteen or twenty thousand jewelers in this country, enough men anxious to provide for their families who are able to carry \$5,000 insurance, and in no other way can they obtain that insurance as cheaply or as surely as the way the League is offering it at the present time.

Now, there may be weaknesses in this style of insurance, there may be weaknesses in the League; but if so, they were implanted there in the foundation of the League. If those who founded the League made mistakes it was due to their ignorance and want of experience.

We who have administered its affairs have managed our trust to the best of our ability. We have done so in spite of these weaknesses; and every change in our constitution and in our manner of working has been with the idea in view of remedying these weaknesses and strengthening the association.

Before closing I wish to bear witness to the faithfulness of the gentlemen who have served you in the offices of President, Vice-Presidents and members of the Executive Committee. I know we are inclined to think that their duties are merely formal, but I assure you that their duties require, and they have given, time and labor in the interests of the association. It is a mutual association—no axe to grind—and everyone has the same interest. They deserve your highest thanks and appreciation.

I thank you for the confidence and accept the office with thanks.

The terms of Joseph B. Bowden as first Vice-President, and of

Charles G. Lewis as second Vice-President, having expired, James P. Snow and Robert A. Johnson, the second and third Vice-Presidents respectively, became first and second Vice-Presidents. Joseph B. Bowden was elected third Vice-President, and Charles G. Lewis fourth Vice-President.

The terms of William Bardel, John R. Greason and George H. Houghton as members of the Executive Committee having also expired, they were unanimously re-elected, the board then standing as it did last year: William H. Jenks, A. A. Jeannot, George R. Howe, William Bardel, John R. Greason and George H. Houghton.

The proposed amendments to the By-Laws were then considered in order, and were, after considerable discussion, adopted.

The first amendment is an addition to Article III.:

At the annual meeting that shall adopt this section there shall be elected by the members of the League, in the manner stated in Section 2 of this article, six advisory members of the Executive Committee, three of whom shall be elected to serve one year and three to serve two years. At every subsequent annual meeting of the League three advisory members of the Executive Committee shall be elected to serve two years, in place of those whose term of office has expired.

Article V., Section 2, was changed to read:

There shall be assessed by the Executive Committee for the payment of death losses, upon each member belonging to the League, prior to January 19, 1886, the sum of \$2, and upon each member admitted subsequent to that date, according to his age at date of admission, as follows, to wit:

From 21 to 29 years, inclusive.....	\$2.00
“ 30 to 34 “ “	2.50
“ 35 to 39 “ “	3.00
“ 40 to 44 “ “	4.00

Article VI. was changed to read:

SECTION 1. The amount arising from the payment, by each admitted member of his first assessment, together with the assessment ordered by the Executive Committee upon each other member, shall be placed in a trust company as a special deposit. Upon satisfactory proof of the death of any member of the League the committee shall pay this amount so collected (less 3½ per cent.), not exceeding \$2 for each member, and in no case exceeding \$5,000 to the person or persons whose names shall, at the time of the death of such member, be found recorded as his last designated beneficiary or beneficiaries, who shall in all cases be some person or persons having an insurable interest in the life of such member; or in case such beneficiary or beneficiaries shall have died, then to such other person or persons as in the judgment of the committee may be most dependent on and entitled to receive from the said member said amount, which shall be distributed as a gratuity, on behalf of such member, among such persons as the committee may deem just and equitable.

Immediately after having ordered payment of a death loss, except where such loss is paid from the contingent fund, the Executive Committee shall order another assessment upon each member, to be used in like manner.

Whenever the amount in this special deposit exceeds the sum of \$5,000 the excess shall be transferred to the contingent fund.

SECTION 2. Any member may, with the approval of the Executive Committee, at his desire and at any time, effect a change as to the person or persons designated as beneficiaries, by filing with the Secretary of the League a certificate setting forth that he does thereby revoke his former designations and does substitute others, as therein designated, in their stead, which certificate shall set forth the same particulars with reference to such other designated parties as was set forth in his original application, and shall be subscribed to by such member and properly acknowledged before an officer authorized to take and certify the acknowledgment and proof of deeds for record in this State, when the Secretary shall make, under the direction of the Executive Committee, the necessary changes in the record.

Art. I, Section I, to the By-Laws, was amended so as to provide that beneficiaries shall only be such as have an insurable interest in the life of the member.

The amendments providing for a half benefit were tabled.

In accordance with the new provision for an advisory board of six, the following were elected: Geo. W. Parks, Chas. L. White, John W. Steele, Ralph Hamilton, Jr., C. C. Offerman and Samuel H. Levy. Samuel A. Baldwin, who had been elected, declined in favor of Mr. Levy.

The following proposition, presented to the members by mail, was rejected:

At the request (and expense for printing) of several members of the League this

slip is inclosed. By affixing signature to one of the following propositions and returning to secretary you will oblige aforesaid members.

E. H. BROWN (266) and others.

1. In favor of establishing a half rate membership, with full vote, as is the case in all beneficial orders.

Signature.....

2. In favor of establishing a half rate membership, but with only half vote.

Signature.....

3. In favor of taking no action in the matter.

Signature.....

NOTE.—The object is to ascertain if members (who find present assessments all they can carry, and who will be compelled to drop out when our assessments reach their normal number) can be told that a half rate membership will be established in 1889.

A vote of thanks was then passed to the officers of the League and to the *Jewelers' Review*, and the meeting adjourned.

Among the members present were:

Robert Welch, Jr., B. W. Ellison, John Gewehr, A. C. Chase, Charles F. Egler, Jr., Ludwig Nissen, James M. Stevenson, J. C. Mount, Joseph F. Ward, C. G. Lewis, Asa C. Fellows, Andrew H. Briggs, R. H. Ryan, Stephen Preston, Jr., Geo. W. Wood, R. L. F. Everett, H. W. Heiller, John F. Minaldi, C. J. Dodgshun, G. M. Van Deventer, Chas. Van de Sande, L. Credner, F. J. Boesse, A. C. Raefle, M. M. Fenniman, H. P. Fletcher, N. J. Tommins, T. B. Hagstoz, Geo. R. Howe, Henry Hayes, C. C. Wientge, Bernard Karsch, F. A. Goeltz, F. W. Pleister, S. B. Mann, Geo. H. Richards, Jr., S. A. Baldwin, R. A. Breidenbach, S. Cottle, Chas. E. Bride, J. C. Cottle, Arthur Rifenberg, Wm. H. Barnet, Geo. Southwick, W. S. Sparrow, W. H. Salt, W. S. Heller, Frank G. Miller, Frederick Walker, George R. Halm (art director the *Home Maker Magazine*), Austin L. Leonard, E. S. McLaughlin, H. Frank Payton, O. M. Atwood, Walter Gardiner, L. Stevens, Jr., J. B. Bowden, Jos. Seeley, John Obrig, A. Frank, G. A. Bantel, G. H. Houghton, P. Thomas, W. W. Stewart, M. Klaber, W. H. Jenks, C. W. Bridgman, W. S. Durand, J. Dorst, H. S. Draper, J. D. Nutt, W. H. Ball, R. A. Johnson, C. D. Harvie, W. Bardel, E. S. Smith, C. L. White, C. E. F. Lewis, Geo. W. Hutchison, A. W. Page, J. Brendel, G. R. Schofield, J. W. Fahr, C. A. Gallagher, H. C. Barnum, H. Euler, F. W. Von Berner, C. C. Offerman, L. Manheimer, C. E. Settle, D. F. Myers, J. R. Greason, S. B. Dinkelspiel, J. D. Yerrington, A. Kurtzeborn, St. Louis; G. W. Parks, D. H. Brown, Otto Caesar, A. H. Myerhoff, C. J. Theuerner, O. N. Wright, Geo. W. Church, Chas. J. Fox, S. B. Kent, C. E. Mott, J. Y. Demott, C. H. Pinnell, L. W. Sweet, D. W. Granbery, A. K. Sloan, T. Evans, A. Milne, J. Strauss, J. P. Snow, C. C. Willemin, W. W. Middlebrook, J. R. McAllister.



[FROM OUR SPECIAL CORRESPONDENT.]

A BRIGHT OUTLOOK FOR THE YEAR.

LONDON, January 8, 1889.

There is every reason for believing that the improved condition of our industries that was apparent at the close of last year will be still further manifested as this year advances. We are justified in this belief not only by reason of the greater demands made on our own manufactures, but also by reason of the increased activity so general throughout the country. Even in the jewelry and allied industries there are fewer men out of work than there have been at the corresponding period for some years past. A good feature of the business now doing is what I consider its soundness; that is, its freedom from speculative tendencies. Articles are manufactured in answer to a demand for them more than has been the custom lately; and, with the brighter prospects of the country, this demand is more likely to increase than otherwise. Our manufacturers are, however, looking hopefully to the trade with our Colonial connections. There is no doubt that they have more to expect from an export trade than from the demand at home. Good reports are coming from the Cape; and, what is more satisfactory, good orders are coming also. The plating houses are also fairly busy, and there are the same encouraging indi-

cations in their branch which I have mentioned as pertaining to jewelry proper. Mappin & Webb are especially active. They have just lately been making a fine show of some well executed Japanese carving in ivory. I saw some paper knives the handles of which are marvellous specimens of this beautiful work. They have some specialties in silverware that are sure of a good sale—amongst them some snake and buckle serviette rings, some new designs in silver pickle forks, and a sardine server; the latter quite new. They are busy preparing the articles for their exhibit at the Paris Exhibition. The French Government has made special arrangements respecting articles to be shown at Paris. A law repealing the Patent Law of July 5th, 1841, and the trade mark, October, 1857, for products sent to the Universal Exhibition, 1889, has passed the Senate Chamber, and has been officially announced. This affords protection to articles exhibited which are not patented in France; but the articles cannot be sold in France, and must be re-exported within three months of the official closing of the Exhibition, or the discovery or invention will be considered as exploited in France. Our own Government, also, by an Order in Council, has relieved intending exhibitors at Paris from the conditions of the Patent Act, 1883.

A singular report reaches me from Coventry. It is said that a company is forming in Lancashire for the purpose of buying up the whole of the watch movement trade. The effect of this is anticipated to be an advance of nearly 20 per cent. in the prices of movements sold to Coventry.

There is still on view in our show rooms a good variety of novelties, in the shape of pins and brooches. Two ducks, a gold one and a green enamel one, are arranged among bulrushes and surrounded by a frame made of twisted cable. Violins, guitars and mandolins in bronze and enamelled gold, are the forms of some pretty brooches. I have just seen a novelty in the way of earrings—a French production. The earrings are small, square lanterns of enamelled gold, with rows of pearls round the framework, and with a ruby, or diamond, or sapphire on the hook and on the pointing base. Other new ideas for earrings are in the form of pet animals and birds, made of brilliants and other stones. Watch bracelets are having a good sale at present, and both ladies and gentlemen are wearing them. I have not attended many festivities this season, except social ones, so that my opportunities of studying the latest productions of our trades in actual use have been limited. But at a ball given in aid of a Jewish charity, at the Hotel Metropole, I had an insight into the lavish expenditure in which many of our Hebrew friends indulge, which is not often afforded us, even in this City of London. The ball was, of course, a most brilliant success in every single detail. Regarded from what I fear my lady friends would call my own narrow point of view—namely, as an occasion for the display and observation of jewels and jewelry—it was unique. If in any assembly you might reasonably expect to find a display of ornamental jewelry, you would surely expect it in a gathering of nearly 450 guests, who were mostly Jewesses. The dresses were magnificent; and, although it is delicate ground for me to tread on, I must say that, in my opinion, there was not one that could be spoken of in any but complimentary terms. In speaking of the jewelry I am on a firmer footing, and from every point in which it can be spoken of, it was a pleasing and instructive study. Speaking generally, there was better taste in the character of the articles worn than is sometimes seen in so large an assembly, the members of which are mostly wealthy. I am pleased to think there is not now that display of massive, expensive ornaments that was so general a few years ago. The taste and skill of the manufacturer are now far more appreciated, and the purchasing public are recognizing the value of artistic design in articles of utility as well as of ornament. It will be to the advantage of the manufacturing jeweler to encourage this higher taste by every means in his power. Our jewelers cannot make much progress by merely buying and selling nuggets of gold and parcels of precious stones. Their art and their living is in the artistic arrangement of the gold, and the judicious and tasteful combination of the stones. But I am

wandering. I found this higher artistic taste which I have attempted to describe, fully exemplified at this ball. One lady had a magnificent suite of diamond ornaments, which were rendered most effective by a dress of moss-green velvet and white satin. Another lady wore a train and bodice of ruby velvet. The bodice had a vest and a folded fichu of satin, studded with diamonds, rubies, and other glittering jewels. I saw the best arrangement of a watch bracelet that I have ever seen. I was not able to obtain a very close inspection. The bracelet itself consisted of a series of small lovers' knots in gold, and a gold, keyless watch, with entourage of fine diamonds. I cannot say that I like the idea of spiders and beetles as dress decorations. Even when they are enhanced by brilliants and rubies they are not inviting subjects. I saw one fair wearer of those uncouth creatures, and I concluded from what I saw that even she was not satisfied with the effect produced. I know we get accustomed to many unlikely notions, but, for my own part, beetles are not in the best taste for a ball room.

Realism is all very well, but I think we are carrying the realistic quite far enough in introducing such monstrosities—Chinese and others—as now decorate (!) our drawing rooms. We must have respect to the "eternal fitness" of things, and young ladies and spiders do *not* harmonize.

Yours faithfully,
VIGILANT.

Birmingham Letter.

[FROM OUR SPECIAL CORRESPONDENT.]

BIRMINGHAM FEELS THE IMPULSE—NEW STYLES AND STAPLES.

BIRMINGHAM, January 12, 1889.

Among jewelers here it is well understood that when other trades begin to improve, the jewelry trade is generally at its worst. During last May a great increase was noticeable in almost all British industries except jewelry; but our time has now come. Whereas the expectations caused by the great revival of most trades during May has not been fully maintained, the jewelry trade is just beginning to feel the effects of this revival. I have just returned from my first journey of this year, visiting most of the largest wholesale houses in the country, and have found almost everywhere that stocks were low and dealers ready to buy well.

No doubt many of your readers are aware that the Right Hon. Joseph Chamberlain, the member of Parliament for the Western Division of our city, has just recently arrived home, after his marriage with Miss Endicott, at Washington. The meeting to welcome them was held on Tuesday last in our Town Hall. Among the presentations made were, of course, several articles of jewelry, one being a necklet of 73 choicest Oriental pearls, strung on fine silk with a single diamond clasp set in gold, the diamond being about a carat in weight. This was supplied by Wm. Spencer & Sons, of 43 Regent Place.

Another present was a six-pointed star composed of fifty fine diamonds of the first water, set in silver with a gold mount, and forms either a brooch or hair pin. The center stone weighs about 1¼ carats, and between the rays of the star are shorter projections, each having a small brilliant in. For wearing at the neck, it is provided with the usual brooch pin, but for use in the hair there is a detachable pin with a spiral spring attached, so that with each movement of the body the star would tremble.

This was made by the same well known firm, and was fitted into a case of maroon velvet, with a silver saw-pierced monogram, "M. E. C.," on the outside, made by T. W. Atkins, of Vyse street.

About twelve months since there was a great run on silver and gold book markers and paper knives combined, almost useless little articles of from 1½ inches to 2 inches long, too small for paper knives and too large for book markers. Since the shops have been stocked with these there has been a quietude in these goods, and

makers have been casting about for something to take its place. As is usual, several houses have hit upon the same idea, and we now see large paper knives of from twelve to fifteen inches in length, with ivory blades and richly chased silver handles. The workers in ivory, noting this, have also made paper knives in all ivory, imitating the part silver ones, and we now see in the jewelers' shops both classes side by side.

It is extraordinary how, when one large firm takes up any line of jewelry, the same idea seems to occur to another one at the same time. Doubtless, in some cases, the one firm copies the idea of the original, but in many cases it is not so.

A case of this kind has just occurred. For years past the trade in gents' gold sleeve links has been in the same hands, and, to some extent, the trade in silver; but just previous to Christmas, two of the largest firms in the trade have started in it almost simultaneously, not only in gold, but in silver too. This is an advantage to buyers, but with the makers it must cause a lot of extra trouble in the keener competition it brings about, even if it does not mean a considerable reduction in profit.

SOLITAIRE.

The Jewelers' and Tradesmen's Company.

GILBERT T. WOGLOM, *President*.
THOMAS A. YOUNG, *1st Vice-Pres.* EPHRAIM S. JOHNSON, Jr., *Sec'y*.
SHUBAEL COTTLE, *2d Vice-Pres.* SAMUEL W. SEXTON, *Treasurer*.

BOARD OF DIRECTORS.

JAMES A. SMITH, M. B. Bryant & Co.
EPHRAIM S. JOHNSON, Treasurer, E. S. Johnson & Co.
SAMUEL W. SEXTON, President Solid Link Chain Mfg. Co.
CHARLES A. FOWLER, Fowler Bros.
JOHN C. DOWNING, Downing & Keller.
SHUBAEL COTTLE, President S. Cottle Company.
THOMAS A. YOUNG, Ex-President National Association of Commercial Travelers ;
Chairm'n Legislative Committee and Vice-President of the Commercial Travelers' Asso'n, State of N. Y. ; President Traders' and Travelers' Union.
CHARLES F. ROBERTS, M. D., *Medical Director*, 69 E. 54th St., N. Y. City.
SAMUEL A. BALDWIN, W. E. White & Co.
GILBERT T. WOGLOM, Gilbert T. Woglom.
WILLIAM B. KERR, Kerr & Battin.
SAMUEL SONDEHEIM, D. & M. Bruhl.
Superintendent, BENJAMIN O. LAMPHEAR,
Counsel, JAMES M. HUNT, (of Rudd & Hunt) 31 & 33 Pine Street.

REPORTS OF THE THIRD ANNUAL MEETING SHOW A GRATIFYING INCREASE.

THE THIRD annual meeting of the Jewelers' and Tradesmen's Company was held on the evening of January 21, 1889, in the temporary office of the company, No. 34 John street, New York City, and was attended by an interested and spirited body of men. The salient points of the reports read met with a prompt recognition.

President Woglom opened the meeting with the following address:

PRESIDENT'S ADDRESS.

Fellow Members of the Jewelers' and Tradesmen's Company:

I greet you with words of cheer and encouragement as to the present and future of our young and energetic society. There has been no time in the 25 months of our existence when the outlook has been as bright as the present.

We have builded steadily and solidly, for the future as well as for the present, knowing that an extraordinarily rapid growth, while very flattering at the time, is not the strongest for all time. The reports of your faithful, painstaking, industrious officers and directors will show you the steady progress we have been making, and it therefore will be my province to make but a few general remarks. I must preface them, however, by expressing to them all, and to our Superintendent and Clerk as well, my sincere appreciation of their untiring support in every effort made to forward the interest of our association; all work together as a unit.

It will be gratifying to you to learn the alacrity with which our membership has responded to our first and only mortuary assessment, there being, out of approximately 600 members, only 24 dropped for non-payment thereof, a very small percentage; but of this number at least five have applied for re-instatement.

A strong feature of our plan, one which we have not given much prominence to

as yet, is the fact that we do not roll up large assets to be held by the company as an object of money worship by our members, simply as a large sum to be admired, as by a child, but not to be touched. Our reserve fund, the accumulation of each block of ten years, after the lapse of the first ten years will have the first year's accumulation thereof distributed and credited to the then persistent members to help pay their assessments for the mortuary fund. When our reserve fund of ten years' accumulation has accomplished its purpose of security in the event of an excessive death rate, we then distribute the useless part among our current members. This principle and purpose differs widely from most moneyed and insurance societies and corporations.

It is a curious anomaly that the security for the promise to pay by most such corporations is held by the corporations themselves, instead of being held by those to whom the securities would mean security. This matter was impressed upon me by reading recently the advertisement in a daily paper of an insurance company stating, after an array of wonderfully large figures and showing a balance of over two million dollars, that "These splendid figures represent the assets, liabilities and surplus to policy holders, respectively, of the So and So Company." Does it not, on the other hand, show an excessive charge for the insurance furnished in past years, now paraded as a reason why others should come in and be alike, with the old policy holders, charged excessive rates and thus further augment these "splendid figures," representing dollars which you may admire but never handle?

Our plan, while fully as secure, presents a more reasonable system for business men to ponder upon. It conforms to the average of the requirements of the insurer and the insured.

Our members may rest assured that our management will be on the alert for any further improvements which may strongly present themselves in furtherance of equity, stability and business prosperity.

Our membership being made up so largely of those who are members of kindred societies, it would seem to be courteous and prudent that we should feel a sympathy rather than an antagonism with kindred institutions. If there be any other spirit with which we should contemplate our fellow institutions, it should be with that of emulation of their good qualities and toleration of all. In the same spirit it should be our pride to be emulated and to have any part of our system adopted, and if possible, carried out by such institutions as may consider it available.

It has repeatedly been demonstrated that no cause gains by intolerance, injustice or misrepresentation towards others who are pursuing a kindred course. Wise competitors in foot races refrain from exhausting their energy in useless badinage; it is more valuable for the purposes of goal-getting. Inspiration, study, executive ability, may produce a beautiful statue, a dream in architecture, which a vicious club may mar, a communist's bomb may scar; it requires no genius to become an iconoclast.

Now, following this homily on our attitude towards others, permit one simple suggestion as to your duty to our own beloved company. The presence of so many at this meeting indicates the interest taken by you in our common welfare. Permit us to further avail ourselves of that interest by asking each of you to receive a card which will be furnished you by our Superintendent, and after finding a fellow tradesman whom you have interested in our plan of insurance, place his name and address thereon and mail it to our Superintendent. The fact of having been the means of introducing and enabling him to write up a member will be a graceful souvenir of your presence here to-night, and will enable your friends each to appreciate the spirit of this quaint clipping from one of our humorous papers:

Wives of rich men oft remind us
 We can make our wives sublime,
 And, departing, leave behind us
 Widows worthy of our time;
 You can give your wife a send-off
 By the life insurance plan,
 So that when this life you end-off
 She can buy another man.

This was followed by Medical Director Charles F. Robert's report:

MEDICAL DIRECTOR'S REPORT.

Mr. President and Members of the Jewelers' and Tradesmen's Company:

I respectfully report that to the date of the last annual meeting, the total number of examinations and supervisions were as follows:

Examinations and supervisions.....	390	
Approved.....	378	
Declined.....	12	390
Since that report and to the present date, the term of our official year, I have		
Examined.....	225	
Approved.....	206	
Declined.....	8	
Advised to withdraw.....	11	225
I have supervised reports of other medical examiners, all of which have been approved.....	25	
Total number of examinations and supervisions for the year...	250	
Approved.....	231	
Declined.....	19	250

Added to the number in last report makes a total of number examined and supervised.....	640	640
Approved.....	609	
Declined.....	31	640

Respectfully submitted,

CHAS. F. ROBERTS, M. D.,
 Medical Director.

New York, January 21, 1889.

President Woglom commented on the fact that 5 per centum of the number of applicants had been declined in the effort to admit none but first-class risks.

Secretary E. S. Johnson Jr.'s elaborate statistical report was read and listened to with marks of approval.

SECRETARY'S REPORT.

Amount of Insurance Written

From December 18, 1886, to January 1, 1887.....	\$254,500.00
" January 1, 1887, to January 1, 1888.....	807,000.00
" January 1, 1888, to January 1, 1889.....	585,000.00
Total amount written Dec. 31, 1888 ...	1,646,500.00

Amount of Insurance in Force.

Amount in force December 31, 1886.....	\$254,500.00
Amount written from Jan. 1, 1887, to Jan. 1, 1888..	807,000.00
Amount in force December 31, 1887.....	1,061,500.00
Amount written from Jan. 1, 1888, to Jan. 1, 1889..	585,000.00
Amount written December 31, 1888 ...	1,646,500.00
Insurance terminated by death.....	\$4,000
Insurance terminated by non-payment....	83,500
Total terminated.....	87,500
Insurance in force December 31, 1888.....	1,559,000.00

Exhibit of Certificates of Policies.

Policies issued from Dec. 18, 1886, to Jan. 1, 1887..	85
" " " Jan. 1, 1887, to Jan. 1, 1888....	275
" " " Jan. 1, 1888, to Jan. 1, 1889....	223
Total number of policies issued Dec. 31, 1888.	583
Policies terminated by death in 1888.....	1
" lapsed for non-payment in 1888.....	24
Total terminated in 1888.....	25
Total number of policies in force Dec. 31, 1888.....	558

Exhibit of Membership.

December 31, 1888, there are	126	members insured for	\$5,000
	98	" "	4,000
	74	" "	3,000
	5	" "	2,500
	96	" "	2,000
	1	" "	1,500
	106	" "	1,000
	2	" "	500
Total membership Dec. 31, 1888	508		
Dec. 31, 1888, there are	50	members insured twice.	
Total number of policies in force Dec. 31, 1888	558		

Exhibit of Applications.

Applications received to January 1, 1889.....	626	626
Applications approved by Executive Committee.....	598	
" rejected ".....	17	
" advised to withdraw by Dr. Roberts.....	10	
" not yet acted on.....	1	
	626	626
Applications approved by Executive Committee.....	598	598
Policies issued for.....	583	
Vacillating applicants....	15	
	598	598

Average Age.

Average age on 85 certificates in force Dec. 31, 1886, is.....	40
" " 360 " " " 1887, is.....	40
" " 320 policy holders " 1887, is.....	40
" " 275 certificates issued during the year 1887 is.....	40

Average age for Jan. 1888, is.....40	Average age for July, 1888, is33
" " Feb. "40	" " Aug. "37
" " Mar. "39	" " Sept. "39
" " Apr. "36	" " Oct. "34
" " May, "33	" " Nov. "37
" " June, "38	" " Dec. "43

Average age for the year 1888 is 37.

Income from Assessments.

On New Insurance.

From December 18, 1886, to January 1, 1887.. .. .	\$382.48
" " January 1, 1887, to January 1, 1888.....	1,153.64
" " January 1, 1888, to January 1, 1889.....	790.27
<hr/>	
Total received on new insurance.....	2,326.39
Mortuary call during November and December, 1888.....	2,186.34
<hr/>	
Total amount received for assessments Dec. 31, 1888....	4,512.73

Amount Received from Assessments on Hand.

Total amount received to January 1, 1889.....	\$4,572.73
Less amount paid for first death.....	1,438.68
<hr/>	
Amount on hand December 31, 1888.....	3,074 05

Amount of Mortuary and Reserve Funds.

Amount of assessments received to January 1, 1889.....	\$4,572.73
Less 20 per cent. amount of reserve fund, Dec. 31, 1888.....	902.54 3-5
<hr/>	
	3,610.18 2-5
Less amount paid for first death.....	1,438.68
<hr/>	
Amount of mortuary fund December 31, 1888.....	2,171.50 2-5

Report for the Year 1888.

Amount of insurance written.....	\$585,000.00
" " terminated by death.....	4,000.00
" " " by non-payment.....	83,500.00
Number of policies issued.....	223
" " terminated by death.....	1
" " " lapsed for non-payment.....	24
Income of annual dues.....	\$3,201.00
" " from assessments, new insurance.....	790.27
" " " mortuary call No. 1.....	2,186.34

Respectfully submitted,

E. S. JOHNSON, JR., *Secretary.*

The Treasurer's (Samuel W. Saxton) report was read by him, showing a balance in the mortuary fund on December 31 of \$2,171.51, and a reserve fund of \$902.54 deposited with the United States Trust Company, after having paid one death benefit of \$1,438.68, the only death since organization.

The annual report of the Directors and Executive Committee was read by the Secretary as follows:

DIRECTORS' REPORT.

The Board of Directors beg to present their annual report.

Certificates in force December 31, 1887.....	Number. 360	Amount. \$1,061,500.00
" " issued during the year ending Dec. 31, 1888	223	585,000.00

A steady, rapid and healthy growth, which is the life of all companies.

It is a great satisfaction to know the confidence the trade has in our plans, which embrace the main and strongest features of all prominent and successful co-operative companies, together with graduate and ageing assessments, making the Jewelers' and Tradesmen's Company the pioneer organization of its kind in the country. This fact is vouched for by the list of prominent men in the trade who are members all of whom are taking a great interest in our success; the many communications received will show a volume of names recommended to us for insurance, many of whom, having been accepted, are now heart and hand with us. One reason for this confidence is that we give insurance pure and simple, at the lowest possible cost; not one penny of our assessments is used for expenses; it is all put into the mortuary and reserve funds. Our members ought also to be proud of the fact that the Jewelers' and Tradesmen's Company is not counted in a list of 116 assessment companies out of 267 whose membership is steadily decreasing instead of increasing. Some of the above have been steadily losing members for the past five years, and it is only a question of a very short time when many go out of existence or coalesce with other stronger institutions.

During the month of October it was deemed best by an all-wise Providence to remove one of our members by death, Mr. E. E. Wadsworth, who had been with us since January 25, 1887, and paid into the Company \$22. The proof of his death was filed and passed upon October 24, and check drawn for \$1,438.68, *i. e.*, 35 per cent. in 20 months.

We cannot well overlook the inducement our plan offers for young men to join us, as is evidenced by the incontrovertible facts and figures shown in our Secretary's report, that the average age of the members to whom certificates were issued

during the year 1887 was 40 years, while those insured during the year 1888 was but 37 years. What better evidence is required than this, that the young man of 25 years has no fear of inequity in placing himself in our membership beside the man of 55 years, knowing full well, as these young men must have known before joining, that the man of 55 was paying what it is worth to carry him per annum, while he (the young man) is paying much less by reason of his lesser age in accordance with our well-digested system of graduated assessments.

Our Executive Committee, upon whom devolves the arduous duty of scanning and passing upon the applications for membership, have held 30 meetings and approved 223 applications, aggregating \$585,000, for the past year.

The Directors desire to express their appreciation in behalf of the members to THE JEWELERS' CIRCULAR and *Jewelers' Weekly*, the leading trade papers, for the space so generously accorded in the publication of our business proceedings during the past year.

Assuring the members that the Directors will use their utmost endeavors to continue the impetus already given our young and lusty company, by the co-operation and sympathy of so many of our energetic members, we subscribe ourselves,

JAMES A. SMITH,	EPHRAIM S. JOHNSON, JR.,
SAMUEL W. SAXTON,	CHARLES A. FOWLER,
JOHN C. DOWNING,	SHUBAEL COTTLE,
THOMAS A. YOUNG,	CHARLES F. ROBERTS, M.D.
SAMUEL A. BALDWIN,	GILBERT T. WOGLOM,
WILLIAM B. KERR,	SAMUEL SONDEHEIM.

It was ordered that all the reports be printed and sent to the members.

An election for three Directors and a Secretary resulted in the election of the present incumbents, Secretary E. S. Johnson, Jr., and Directors James A. Smith, E. S. Johnson, Jr., and Samuel W. Saxton.

An informal discussion was entered into in order to get the sense of the members present as to the practicability of making mortuary assessments at stated periods during each year instead of when deaths occur, and was participated in by Vice-President Thos. A. Young, Supt. Benj. O. Lamphear, Theo. L. Parker, Alex. C. Chase, M. D. Rothschild, Director Sam'l A. Baldwin, Lysander T. Best, D. K. Perrine and President Woglom, Vice-President Young presiding in the interim. The debate was interestedly carried on, and evidenced careful study by the participants of the requirements of assessment insurance. The subject, on motion of Mr. Rothschild, was finally committed to the Board of Directors for consideration, to be reported on with recommendations to the full membership at a future meeting, and thereupon on motion the meeting adjourned. Besides the gentlemen already named, among those in attendance were Edwin A. Thrall, Directors Shubael Cottle and Chas. A. Fowler, Solomon Bass, L. W. Sweet, Rudolph A. Breidenbach, Laurin W. Burton, Wm. L. Supple, Louis E. Smith and Chas. A. Ludlow.

After the meeting an informal dinner was partaken of by the officers and directors of the company and representative of the trade journals, at Heckman's restaurant in William street. President Woglom and Vice-President Young were the positive and negative poles of the magnetic circle formed round the table, and the latter in particular was surcharged with an unfailing store of good stories and bad puns which brought forth peals of laughter from his appreciative listeners. Others followed in the same vein, and if good cheer and good spirits in equal parts are as efficacious as they are reputed to be, none of those who participated were troubled with indigestion. About nine o'clock the company disbanded at peace with themselves and the world.

A SMALL WATCH.—A watch of only $\frac{3}{16}$ of an inch in diameter is shown in a Swiss museum. It is located in the end of a pencil. The dial does not alone indicate the hours, minutes and seconds, but also the days of the month. The watch is a memento of a time when such pieces of art work were introduced in snuff cases, shirt studs or finger rings. They were made in different shapes: oval, octagon, crossform, etc.



The following list of patents is compiled from the records of the United States Patent Office, and specially reported to THE JEWELERS' CIRCULAR.

Issue of December 25, 1888.

- 395,110—CLOCK STRIKING MECHANISM.** CHAIM ARONSON, Brooklyn, N. Y. Filed Dec. 7, 1887. Serial No. 257,191. (Model.) In a clock, the combination, with the minute hand shaft, of a helical-edged cam operated from the said shaft, a lever connected at its upper end with the said helical-edged cam, a transverse sliding shaft operated on by the said lever and carrying an arm or lug, and a disk provided with pins gradually increasing in length when set in motion by the striking mechanism, said pins operating on said transverse shaft which operates the striker.
- 395,148—BRACELET.** ALICE JOHNSTONE, Avondale, N. J. Filed Sept. 5, 1888. Serial No. 294,642. (No model.) This bracelet has an orifice in its side, the button hook consisting of a curved loop, the ends of which are bent to fit the hole in the bracelet, whereby the hook may be swung outward for use and inward when not in use.
- 395,166—WATCH WINDING MECHANISM.** CHARLES MORLET, New York, N. Y., assignor of one-half to PROSPER NORDMAN, same place. Filed April 25, 1888. Serial No. 272,101. (No model.) The combination with the spring barrel, mainspring and winding arbor of the same, of a cam keyed to said arbor and provided with a heel, a gear wheel placed loosely on the winding arbor, a stop spring attached to said gear wheel and engaging the heel of the cam, and intermediate winding gear wheels operated from the stem of the watch movement.
- 395,182—COMPENSATING WATCH REGULATOR.** WILLIAM H. SHEAR, Albany, N. Y. Filed March 10, 1888. Serial No. 266,856. (No model.) There are in combination, with balance wheel and spring, a compensating bar, a screw-threaded stem pivoted to the free end of said bar and provided with a nut adjustable thereon, a regulating arm engaging with said nut, said arm being provided with depending curb pins, a fixed screw-threaded rod having a nut adjustable thereon, the outer end of the screw-threaded stem engaging with said nut, a second arm connected to the outer end of the balance spring, and a link connecting said arm to the compensating bar.
- 395,209—WATCH CASE PENDANT.** PARK A. C. BRADFORD, Coffeyville, Kans. Filed Aug. 2, 1888. Serial No. 281,718. (No model.) The pendant stem is provided with longitudinal dovetailed slots, the bow or ring has dovetailed ends engaging said slots and there is a detachable dovetailed keeper.
- 395,224—COMBINED CANE, FLASK AND DRINKING CUP.** JAS. E. HALE, Plainfield, N. J., assignor of one-half to Thomas Keddie, Brooklyn, N. Y. Filed July 23, 1888. Serial No. 280,769. (No model.)
- 16,128—GOLD, SILVER AND PLATED WARES FOR HOUSEHOLD USE.** The Wm. Rogers Manufacturing Company, Hartford, Conn. Application filed November 2, 1887. Used since June 1, 1887. "A representation of two anchors with the word 'Rogers' between them."

Issue of January 8, 1889.

- 395,696—TIMEPIECE DIAL.** MARTIN V. B. ETHRIDGE, Boston, Mass., assignor of two-thirds to John Swann, New York, N. Y., and Henry E. Waite, West Newton, Mass. Filed Jan. 18, 1888. Serial No. 261,080. (No model.) A shifting inner dial is combined with relatively adjustable weights carried thereby on opposite sides of the central support of said dial and mechanical devices for adjusting the weights, consisting of a cam acting on projecting points on the dial, a connection between the cam and the weight on the opposite side of the dial center, and actuating gearing for the cam.
- 395,754—CANON PINION FOR WATCHES.** DOLPHAS D. PALMER, Waltham, Mass. Filed June 2, 1888. Serial No. 275,815. (No model.) This canon pinion for watches has spring acting arms, and an independent tubular staff.
- 395,811—MEANS FOR ATTACHING EYE-GLASSES TO HEAD APPAREL.** WILLIAM H. BROWNLOW, Brockville, Ontario, Canada, and JOEL S. WARNER, Ogdensburg, N. Y., assignors of one-third to John H. Brownlow, Ogdensburg, N. Y. Filed June 6, 1888. Serial No. 276,237. (Model.)
- 395,946—OPERA GLASS HOLDER.** HENRY BORSCH, Chicago, Ill. Filed March 29, 1888. Serial No. 268,828. (No model.) This is a detachable opera glass holder provided with slots at right angles to each other, forming a four-pronged clasp adapted to embrace the opposite sides of the cross bar and to receive the nut on one side of said bar and the spindle or screw on the other.
- 395,872—BINOCULAR GLASS.** JAMES E. BRIGGS, Brooklyn, N. Y. Filed Aug. 7, 1888. Serial No. 282,132. (No model.)

Design Patent No. 18,841—ORNAMENTATION OF CLOCK CASES. WALTER CAMP, New Haven, Conn., assignor to the New Haven Clock Company, same place. Application filed Aug. 13, 1888. Serial No. 282,659. Term of patent 7 years.

Trade Mark No. 16,168—WATCHES, WATCH MOVEMENTS AND WATCH CASES. EMILIE QUARTIER, Fils, Brenets, Switzerland. Application filed November 17, 1888. Used since July 29, 1887. "The representation of a bell."

Trade Mark No. 16,155—WATCHES. M. C. EPPENSTEIN & Co., Chicago, Ill. Application filed November 5, 1888. Used since October 15, 1888. "The word 'Giant.'"

Issue of January 15, 1889.

- 396,091—HANDLE FOR CUTLERY.** FREDERICK R. KALDENBERG, New York, N. Y. Filed Dec. 9, 1887. Serial No. 257,472. (No model.)
- 396,092—GEM SETTING.** DAVID KUTNER, Brooklyn, N. Y. Filed May 26, 1888. Serial No. 275,233. (No model.) This improved gem box is provided with set screws terminating in flattened portions, and the gem is provided with a slotted opening.
- 396,095—COMPENSATION PENDULUM.** ALVIN LAWRENCE, Lowell, Mass. Filed May 2, 1888. Serial No. 272,605. (No model.) We have a screw nut, a segmental or slotted cylinder having screw threads thereon, and a rod fitting within said cylinder and also having screw threads thereon, the nut engaging the threads of both the cylinder and the rod whereby the cylinder and rod are connected together by the nut
- 396,264—EYE-GLASSES.** HENRY BORSCH, Chicago, Ill. Filed March 29, 1888. Serial No. 268,829. (No model.) The round wire nose piece is bent into an inverted U-shape, with one arm longer than the other, the outer extremities of the arms being free of each other, and the shorter arm secured to the clasp with the free end of the longer arm extended below the end of the shorter arm.
- 396,144—EYE-GLASS HOLDER.** HENRY J. DALE, Chicago, Ill. Filed June 6, 1888. Serial No. 276,240. (No model.) This eye-glass holder consists of a body portion, a safety pin substantially parallel with the body, an aperture or recess in the upper portion of the body, and a hook bent from the same piece of metal as the body of the holder, having its upper end bent downward and inward, and shaped to fit in the recess in the upper portion of the body.
- 396,267—DUST BAND FOR WATCHES.** DUANE H. CHURCH, Newton, Mass. Filed June 23, 1888. Serial No. 277,988. (No model.) There is an elastic seating or bearing at one edge, whereby a yielding pressure is imparted to the band when it is incased.

LABELS.

- 5,799—Title:** "LABEL FOR LENSES." Johnston Optical Co., Detroit, Mich. Application filed Dec. 10, 1888.
- 5,800—Title:** "LABEL FOR LENSES." Johnston Optical Co., Detroit, Mich. Application filed Dec. 10, 1888.
- 5,801—Title:** "LABEL FOR LENSES." Johnston Optical Co., Detroit, Mich. Application filed Dec. 10, 1888.
- 5,802—Title:** "LABEL FOR LENSES." Johnston Optical Co., Detroit, Mich. Application filed Dec. 10, 1888.
- 5,803—Title:** "LABEL FOR LENSES." Johnston Optical Co., Detroit, Mich. Application filed Dec. 10, 1888.

Issue of January 22, 1889.

- 396,598—CLOCK STRIKING MECHANISM.** WILLIAM H. POOLE, Oxford, Iowa. Filed June 24, 1887. Serial No. 242,348. No model.
- 396,655—CLOCK.** HERMANN HERWIG, Media, Pa. Filed October 12, 1888. Serial No. 287,898. No model. The barrel carries a rigidly-attached gear loosely mounted on the shaft or arbor; a wheel consisting of the gears, rigidly connected together and of unequal diameter, is loosely mounted on the same arbor, and there is a pinion journaled on a stud projecting from the flat face of the larger gear of said wheel, said pinion meshing with the gear carried by the barrel, and carrying a pinion which meshes with the smaller gear of the wheel.
- 396,657—OPERA GLASS.** GUSTAV HOLLE, Philadelphia, Pa. Filed Feb. 1, 1888. Serial No. 262,647. Model. This opera glass is provided with an eye-lens yoke and an object-lens yoke, a telescopically-related extensible device, the parts of which are secured to the extremities of the yokes for adjustably connecting said yokes, and capable of sufficient contraction to bring the lens-yokes into immediate proximity, and suitable mechanism for causing the extension or contraction of said extensible device.
- 396,661—STUD OR OTHER JEWELRY.** ADOLPH LUTHY, New York, N. Y., assignor to A. Luthy & Co., same place. Filed Feb. 10, 1888. Serial No. 263,624. No model. There are the base, a stem projecting therefrom, and two radial fastening-arms, the one rigid with said stem and the other mounted to turn on the axis of said stem and adapted to fold against the rigid arm or to be turned outwardly therefrom, stops on the relatively-moving parts to hold the turning arm in coincidence with the rigid one, and inclines on the moving parts, respectively, to hold said turning arm frictionally in place when turned away from the rigid arm.



TRADE GOSSIP.

The following dealers were noticed in town since our last issue :—

J. A. Schwarz, Philadelphia; F. B. Hall, Bridgeport; W. Horton, Middletown, Conn.; A. W. Wright, Detroit; W. Rosenthal, Denver; H. Deimel, Herkimer, N. Y.; A. Herman, Cincinnati; A. G. Schwab, Cincinnati; M. Kingsbacker, Pittsburg; A. J. Hartogensis, Baltimore; H. Felsenthal, Louisville; J. Allen, Toronto; G. Flershem, Chicago; J. E. Jenner, Milwaukee; C. S. Hardy, Pittsburg; S. H. Bauman, St. Louis; F. S. Ring, Detroit; M. Bonn, Pittsburg; A. Horowitz, Hudson, N. Y.; J. Rosenstock, Baltimore; A. Hirsch, Chicago; A. J. Stark, Denver; W. S. P. Oskamp, Cincinnati; E. H. Merrill, Portland, Me.; J. Rosenfeld, Galveston; D. H. Buell, Hartford; T. M. Knight, Philadelphia; D. Oppenheimer, Baltimore; W. J. Atkinson, Philadelphia; S. Kind, Philadelphia; H. Keck, Cincinnati; H. C. Payne, Goshen, N. Y.; G. G. Bannerman, Milwaukee; A. Weed, Stamford, Conn.; J. K. Burnham, Kansas City; I. M. Kallmeyer, Detroit; L. E. Weill, Buffalo; M. Kohner, Baltimore; H. Leiter, Syracuse; I. Ollendorf, Pittsburg; S. A. Rider, St. Louis; A. C. Anderson, Toronto; Henry Dreyfus, Montreal; C. C. Sigler, Cleveland; A. H. Bonnet, Zanesville, O.

—C. Arnkens, Elkhart, Ind., is reported in financial difficulties.

—C. H. Bronk, Hudson, N. Y., has retired from the jewelry business.

—Among recent deaths is that of L. H. Solomonson, a prominent optician, of Cleveland, O.

—F. A. Ackerman, Canajoharie, N. Y., is selling off his stock and intends to locate elsewhere.

—J. Miller, Cleveland, O., has been closed up under judgments. His assets are nearly \$3,500.

—Jacob Bunn, Jr., will succeed W. F. Cory as New York agent of the Illinois Watch Company.

—F. M. Marshall has opened a general jewelry store at Rock Bar Landing, Ky., on the Ohio River.

—George Leibel, of Louisville, Ky., has opened a small establishment of his own in Jeffersonville, Ind.

—George L. Streeter, the New Haven jeweler, is convalescent. Meanwhile his store is in charge of his wife.

—William Crosby has just opened an attractive little establishment at 1,111 West Market street, Louisville, Ky.

—W. F. Clark, Jeffersonville, Ind., has associated himself with J. R. Kevil, and opened a store at Princeton, Ky.

—Hugo Seidenfaden, a practical jeweler, of Louisville, Ky., has opened a store on Shelby street, near Broadway.

—The stores of W. A. Scott and J. A. Prosser, New Cumberland, W. Va., were destroyed by fire on Christmas night.

—William A. Smith has started a factory for the manufacture of spectacles at Nos. 202-208 Cedar street, Reading, Pa.

—Marcus Schwed, New Haven, Conn., failed on January 6, with liabilities of about \$12,000 and assets of \$4,000. He offers 33½ per cent.

—John Foley, the gold pen maker, 18 John street, has incorporated his business under the title of the Foley Gold Pen Co., capital stock \$100,000.

—W. L. Hollister, the Battle Creek, Mich., jeweler, who became insane some months ago, is rapidly sinking and his death is looked for speedily.

—The last month or six weeks has witnessed the death of three of Maine's oldest jewelers—Oliver Gerrish, William Senter and Jacob M. Crooker. Mr. Crooker, who died at Waterville, December 18, had carried on a jewelry business there for more than fifty-seven years. He was 79 years of age, and during his long career had amassed a competence. He leaves no children.

—During the holiday season J. Kendall Smith, the enterprising Newark retailer, tried the experiment of having three pretty female clerks behind his counter. It is said to have paid him well.

—H. B. Luke, formerly with Kent Bros., of Toronto, who started business a short time ago on his own account, has gone to Des Moines, Iowa, to live, and it is said intends going into business in that city.

—Owing to the recent decease of Meyer Friede, President of the M. Eisenstadt Jewelry Co., St. Louis, E. Achard has been elected President in his stead, and S. Eisenstadt, Vice-President and Secretary.

—Irick & Co., Gainesville, Texas, have made an assignment. They were attached by P. W. Sims, the former owner of the business, who had sold out and moved to Weatherford, receiving notes in payment, which became due and were not met.

—The firm of Settle & Garrettson, Russellville, Ky., has been dissolved, Ben. Settle retiring to go into business for himself at Franklin, Ky. A new firm, composed of George H. Settle and A. H. Richards, has been formed to continue the old business.

—On account of lack of facilities in their present location, the Cheshire Watch Company are contemplating a removal of their works from Cheshire, Conn., to Attleboro, Mass. This will add another important industry to those for which the busy little New England town is already famous.

—Wattles & Sheaffer, Pittsburg, Pa., have moved across the street into the store formerly occupied by A. Kornblum, optician. Mr. Kornblum has taken the old store of R. Siedle, the latter having rented the building vacated by Wattles & Sheaffer. Moving day is beginning early in Pittsburg.

—W. F. Ross, a jeweler, of Toronto, has a pink pearl, which is probably the most valuable of its kind ever found in Canada. It was found in the maritime provinces, is about as large and as perfectly shaped as a small marble, and is of a beautiful pink color throughout. He values it at \$1,000.

—Henry Horwitz, who has had charge of the diamond department of Stern Bros & Co., 30 Maiden Lane, for the past two years, has severed his connection with that house and entered into partnership with a diamond cutting and polishing firm of Amsterdam. He will shortly open an office in New York with a full stock of goods.

—Durand & Co. finished an unusually high-priced job recently. It was the mounting in a necklace of one of the largest diamonds in America, weighing about forty-five karats and valued at \$50,000. It was said to be slightly off color, or otherwise its value would have been doubled. It belongs to a prominent New York gentleman.

—The Terry brothers have sold out their interest in the Terry Clock Company, of Pittsfield, Mass., to S. N. Russell and E. G. Jones, who will conduct the business under the style of the Russell & Jones Clock Company. The Terry brothers went from Waterbury to Pittsfield eight years ago, and in that time have built up a very prosperous business.

—During the night of the 7th of January burglars entered H. M. Betz's jewelry establishment, Reading, Pa., bored open a safe and took watches and jewelry valued at from \$1,200 to \$1,500. Nothing was known of the robbery until the following morning and there is no clue to the robbers. Mr. Betz's main business place is in Philadelphia, the store at Reading being a branch.

—Speaking of Portland watch dealers, the *Transcript* says: "Henry S. Pearson, long the Nestor of the trade, was engaged in it in Portland for more than 65 years; the venerable Oliver Gerrish died recently over 90 years old; Abner Lowell was over 70 when he died; and now William Senter has departed at the good old age of 75, after a connection with the business of over 60 years." Ex-Mayor Senter was a wonderfully preserved young man. When he was past 60 he used to slide down hill on moonlit nights, and he kept up his annual gunning expedition till he was after 70. He never grew old.

—H. D. Perkins has succeeded F. J. Childs, Stanton, Neb.

—Carlson & Sandstedt have started in the jewelry business at Wilcox, Neb.

—A. K. Shiebler, of Jeannot & Shiebler, has gone to California on a six weeks' business trip.

—Geo. A. French, with Wm. S. Hedges & Co., sailed for Europe on steamer *Elbe* January 16.

—John Clark, Oakland, Cal., has filed a petition in insolvency. His liabilities are \$2,494.58, and his assets \$859.

—McGee & Unger, Dayton, Ohio, have dissolved partnership. A. J. Unger will continue the business alone.

—Honold & Meyer, Ansonia, Conn., have dissolved partnership, and Mr. Honold will succeed to the business.

—The Ohio Watch Tool Company, Piqua, Ohio, is said to be contemplating the erection of a factory in Chicago.

—I. N. See, formerly with E. Ira Richards & Co., will represent Unger Bros. in the South and on the Pacific Slope.

—Courvoisier, Wilcox & Co. will shortly move their factory from Brooklyn to Roseville, N. J., where a new building is being erected for them.

—The factory, tools, etc., of G. H. Loehr, Chicago, have been sold to Riehm & Beygeh, afortime employees of Juergens & Andersen.

—The store of James H. Arnold, Columbus, Ind., has been closed by the sheriff on a suit of attachment for \$2,500 in favor of A. & J. Plaut, of Cincinnati.

—A. Hodenpyl, of Hodenpyl & Sons, importers of diamonds, 170 Broadway, sailed for Europe January 19 on the *Gasconne*, to make purchases for the spring trade.

—Frank W. Sackett, who has been with Mulford & Bonnet for over 14 years, now represents T. J. Gardiner, Jr., & Co. and Gladding & Coombs Bros., of Providence.

—A new jobbing firm, Henry Froelich & Co., has opened offices at 40 Maiden Lane. The partners are Henry Froelich, until recently traveling salesman for Marx & Weis, and S. W. Froelichstein.

—Hainsfurther Bros. have started a jobbing business at Petersburg, Ill. The two brothers composing the firm were formerly associated with their father in the dry goods business at that place.

—L. Newman, Jr., gold plater, of 36 John street, is reaping the reward which industry and integrity never fail to bestow, in a largely increased business. We can heartily commend him to the trade as well worthy of patronage.

—The firm of Heinze & Gardner, 5 and 7 Maiden Lane, was dissolved on January 12. Charles R. Gardner has bought out Mr. Heinze's interest and will conduct the business under his own name, making a specialty of sterling silver novelties.

—H. H. Heinrich, chronometer maker, of 14 John street, New York, is preparing three chronometers, *with all his improvements*, for the great exhibition in Paris, which opens in May next. We confidently expect to see Mr. Heinrich bear off one of the prizes.

—Henry Oehl, an expert watchmaker, who has been in the employ of several of the newer watch manufacturing enterprises during the past three years, has opened an office at No. 41 Maiden Lane, where he will devote himself to the repairing and adjusting of watches.

—Mr. Miller, general selling agent of the New York Standard Watch Co., showed THE CIRCULAR's reporter the other day a very curious old silver watch that was presented to Marshall P. Wilder, the humorist, by an English princess. It is a French repeating watch, 3¼ inches in diameter, very heavily cased, and the back, which is perforated around the edge, is beautifully engraved or enameled in colors. The movement has a verge escapement, and the total weight of the timepiece is not far from one pound. Strange to say it is a lady's watch. It is valued at £500.

—The Jackson (Mich.) *Citizen* recently published a very creditable "Industrial Edition," containing among the notices of its chief manufacturing and mercantile enterprises an interior view of the store of Gaylord G. Case, with a sketch of the proprietor's business career.

—Richard T. Supple, who has been connected with the house of D. C. Percival & Co., Boston, Mass., has made arrangements to represent Keller & Untermeyer on the road for the coming year. He is a brother of William L. Supple, the popular traveler for M. B. Bryant & Co.

—At the annual meeting of the stockholders of the Trenton Watch Co., held at Trenton on January 8, the following officers were elected for the ensuing year: President, J. Hart Brewer; Secretary, S. P. Camp; Treasurer and General Manager, Geo. R. Whittaker; Superintendent, S. T. J. Byam. The capital stock was increased from \$300,000 to \$500,000.

—H. E. Duncan, manager of the non-magnetic department of the Waltham Watch Company, delivered a very interesting lecture recently before the Boston Electric Club, on "Recent Problems in Watch Manufacture." The lecture was illustrated by appropriate models, showing the parts of the watch that are exposed to magnetic influences, and was followed by a general discussion.

—When Chas. A. H. Neidhardt, 777 Fulton street, Brooklyn, arrived at his store on the morning of the 15th, he found the front pane of his show window smashed and about \$150 worth of goods missing. The police in the neighborhood were utterly oblivious to the fact that a deed of violence had been done under their very noses, and Mr. Neidhardt thinks they are more ornamental than useful.

—Meyer A. Rosenblatt, formerly a prominent jeweler of St. Louis, died there recently of diabetes, aged 47 years. He traveled extensively in his early life, and in 1863 he settled in St. Louis as junior partner of the firm of S. Bauman & Co. He was a prominent Republican and had held many offices during the past twenty years. He leaves a widow and three children in affluent circumstances.

—The National Watch Case Company (limited), 715-17-19 Arch street, Philadelphia, have just closed a prosperous season, and are preparing for another which they are confident will be one of still greater prosperity. Their factory is a model in point of roominess, neatness, light and equipment. Every improvement in the line of watch case manufacture has been utilized, as well as every convenience that could add to the comfort and health of the employees. In addition to their unexcelled 14 and 18 karat gold cases, they are making large quantities of the solid, seamless, wrought gold rings patented by A. Humbert, which are chiefly superior to the old style ring because they contain no solder. A talk with Mr. Schober, the gentlemanly secretary of the company, and a walk through their superb factory is enough to convince anyone that when they say they are getting down to business now they mean it. They are going to surprise the trade with another little novelty, about which they may have something to say in our next issue.

—The late Mrs. Gardner Brewer, of Chicago, had a hobby for collecting watches. In a case, of which she kept the key herself, was a choice array of timepieces, ranging from big Dutch affairs, which can be peeled layer after layer like an onion, to the daintiest of enameled jeweled watches used by French beauties of the empire. Some of these had once belonged to those whose names are famous in literature or society. Mrs. Brewer employed an expert to look up these things, but depended on her own judgment as to their value. This agent reported that an old lady in Washington, indirectly connected with George Washington's family, had a silver watch once carried by the first president. Mrs. Brewer found the old lady in destitute circumstances and quite willing to part with the watch for a small sum. After verifying the data given about the watch, Mrs. Brewer told her it was worth many times the price she asked, and after consultation with other connoisseurs of antiques, she deposited in the bank a sum which insured the old lady every comfort even if she lived to be a century old.

—Truman Reeves, San Bernardino, Cal., has made an assignment.

—G. J. Markowitz, Fresno City, Cal., has assigned to W. W. Phillips.

—F. W. Clayton, Medford, Or., has sold out his business to Fred. O'Bryan.

—John W. Poe, Centralia, Ill., has failed, with liabilities of about \$14,000.

—Chas. J. Crantz has moved from Auburndale, Fla., to Laheland, same state.

—The New York office of Joseph Muhr has been moved from 18 to 14 Maiden Lane.

—Ferdinand Sitt has opened a new jewelry store at 214 East Fifth street, Dayton, O.

—Geogre W. Ludwig, Chambersburg, Pa., is mourning the death of his infant daughter, an only child.

—A new jobbing firm, L. Cohen & Co., has started in business at 202 Grand avenue, Milwaukee, Wis.

—George Elting & Co., 304 North Fourth street, St. Louis, Mo., have retired from business.

—Two assignments have occurred in Kansas City during the past month—J. H. Barr & Co., and J. O. Hauser.

—The new addition to the factory of the Columbus Watch Co. will enable them to turn out 250 movements a day.

—A. L. Reinhardt has bought the stock of John W. Poe, Centralia, Ill., from the assignee, and will continue the business.

—Ira W. Shattuck & Co., Wilmington, Del., have confessed judgment for \$3,000, and the stock has been sold at sheriff's sale.

—B. N. Cardoza, Minneapolis, Minn., has made an assignment, but says he expects to pay his creditors nearly if not quite in full.

—Judgments aggregating \$27,239 have been entered by foreign creditors, against Henry Lewie, importer of diamonds at 120 Chambers street.

—E. Hibbard has retired from the firm of Hibbard Bros., Buffalo, N. Y., and the business will be conducted by his brother, William Hibbard.

—Joseph B. Mayer, the Buffalo diamond merchant, has admitted his brother-in-law into partnership, the firm name becoming Mayer & Gugenheimer.

—George H. Houghton, of the Gorham Manufacturing Co., will go to Europe in May to take charge of the company's exhibit at the Paris Exposition.

—Ernest Adler, importer of diamonds, has moved from No. 14 Maiden Lane to No. 176 Broadway, where he takes the desk of R. J. Herbert, now absent in Europe.

—The business of Charles L. Walker, Sherburne, N. Y., has passed into the hands of George N. Lathrop and George H. Metzgar, who will continue it at the same place.

—Rosenblatt & Ettinger, manufacturing jewelers, Crosby street, have dissolved partnership, and the business will be discontinued. Mr. Rosenblatt will engage in the wholesale business at 202 Broadway.

—Sigmund Stern, jobber, 52 Maiden Lane, made an assignment recently, with liabilities in excess of \$35,000, mostly owed to Eastern manufacturers, and assets of about \$15,000, principally in outstanding accounts.

—Hollinshed Bros., 806 Chestnut street, Philadelphia, have our thanks for a neat little calendar. It will not be the fault of our friends if we do not take good note of the flight of time during 1889.

—Wright, Kay & Co., the enterprising Detroit retailers, issued a very neat little cardboard souvenir to their patrons, on the cover of which is a picture of a youth curtsying, and asking, "What D'ye lacke, goode Folkyes?"

—John C. F. Miller, Troy, N. Y., has failed, with liabilities of \$17,000 and assets of about \$10,000. His wife holds a mortgage for \$1,200 on the stock for salary, she having ostensibly occupied the position of clerk, and the stock was sold to satisfy the claim.

—Warren G. Smith & Co., makers of white stone goods, 170 Broadway, have thoroughly refitted their fine, roomy office, and it is now one of the lightest and most convenient in the jewelry district. They are making a specialty of baseball novelties, which now find an extensive sale.

—Mr. Matsumoto Jutaro, a well-to-do merchant of Osaka, with the assistance of several others, has established a factory with a capital of *yen* 50,000, for the purpose of manufacturing imitations of foreign goods imported into Japan, with the view of supplanting the foreigners' trade.

—THE CIRCULAR acknowledges the receipt from P. W. Ellis & Co., the Toronto jobbers, of a lithographic calendar, representing a ruddy-faced mariner of the ancient type, with eyes bent upon a telescope, which he holds in his hands, and which is labelled with the business card of this enterprising firm.

—Irving L. Russell, late with Randel, Baremore & Billings, has opened an office at No. 18 John street. He will make a specialty of diamonds, sapphires and fancy pearls, and will be pleased to send goods on memorandum to responsible persons, or furnish designs and estimates for diamond jewelry.

—Two new jewelry concerns were incorporated in Minnesota last month—the Stone Jewelry Company, of St. Paul, with \$10,000 capital. John J. Gavin, Elizabeth Troy and Minnie S. Gavin, all of St. Paul, incorporators; and the Warner Jewelry Company, of Minneapolis, which amended its original articles, incorporating with \$50,000.

—Joseph Wienhold, 24 John street, has admitted into partnership William Walther, who has been eighteen years in his employ, and the firm name will henceforth read Joseph Wienhold & Co. They will continue the importation of diamonds and the manufacture of fine diamond jewelry, commenced by Mr. Wienhold in this city over 30 years ago.

—The unanimous verdict of the watch dealers who have examined the new movement of the New York Standard Watch Co., pronounce it as the best low priced movements now on the market. It is a seven jeweled movement, fitting any regular made American case. It will find a ready market, there is no doubt, and the retail watch dealers will probably take the entire product of this company for a long time to come, although extensive arrangements have been entered into to largely increase the output. It has been the wonder of many how this new movement and tools and machinery for it could have been gotten out in so short a time. The advertisement of the new 18 size watch came in after the other advertisement of the Standard had gone to press, and to any who may be puzzled by this fact we would say that as usual Mr. Miller got there in time.

—The great increase in the demand for musical boxes within the past few years is due largely to the enterprise of Jacot & Son, 37 Maiden Lane, who have, by introducing new methods into the business, and placing on the market musical boxes of superior qualities of tone, with marked improvements in their construction, succeeded in popularizing the musical box to a considerable extent. Mr. Jacot, the senior member of the firm, is the inventor of Jacot's Patent Safety Check, which will prevent what is known as the "run," as it instantaneously checks the cylinder whenever, by any cause, its speed is unduly increased. This invention has already saved many valuable music boxes. Another special feature of their musical boxes is their new Patented Interchangeable Cylinder Concerta. Jacot & Son are sole agents for Mermod Frères, of St. Croix, Switzerland, one of the largest manufacturers of musical boxes, established in 1840.

—The Jewelers' Mercantile Agency state that the year just closed has been the most successful in their history. The old adage that competition is the life of trade has been verified in their case, for the past three years have brought to them an unprecedented increase of business. The new edition of their rating book contains forty pages more than the issue of the preceding January, indicating a growth in the legitimate jewelry trade that is truly marvelous. When a comparison is made of what they furnished to their subscribers in 1873, the year when the organization was formed, with what their present facilities enable them to furnish, a good illustration is given of what energy and capital can accomplish in a special field of agency work. Their plant to-day represents an expenditure of over \$200,000 solely in the interests of the jewelry trade, their annual expenditures largely exceeding those of any general agency for that trade. These facts are thoroughly appreciated by the jewelry trade.

—Adolph R. Hutten, recently with Vve. L. B. Citroen & Co., is now in the employ of Wm. S. Hedges & Co., as salesman, in place of W. M. Post.

—D. De Sola Mendes, importer and cutter of diamonds, 49 Maiden Lane, left for Europe on the *Gallia* January 19, to purchase goods for the spring trade.

—W. J. Atkinson, of Atkinson Bros., Philadelphia, the wide-awake agents for the keystone watch, is sojourning on the Pacific coast on business and pleasure bent.

—We have received a very useful calendar from Samuel C. Jackson, jewelry case manufacturer, of 180 Broadway, N. Y., for which we desire to return acknowledgements.

—Krementz & Co., manufacturers of the well-known *one-piece* collar button, have made improvements in their factory by which they will be enabled to meet the increasing demand for this superior button.

—Maxheimer & Beresford, manufacturers of fine diamond jewelry, have moved from No. 5 John street to No. 3 Maiden Lane, where they will have more room at their disposal. They make a specialty of order work.

—Henry Henze having sold out his interest in the late firm of Henze & Gardner to his partner, Charles R. Gardner, who assumes all liabilities, has taken a shop at No. 96 Fulton street and will soon be ready for business again.

—Edwin Want, manufacturing optician, of 28 John street, offers to the trade a well selected stock of the highest grade of goods, and still continues his specialty of repairing in the best manner all sorts of optical instruments, eye-glasses, spectacles, etc.

—The Western Clock Company, La Salle, Ill., manufacture a line of improved clocks, under the Chas. Stahlberg patent, that have a number of features to recommend them to the trade. The clocks they are introducing are quick train, with straight line, club tooth escapement, and the springs are polished and encased in barrels. They are both durable and cheap.

—A. J. Hedges & Co., 6 Maiden Lane, are preparing an elegant line of their unequalled variegated and enameled jewelry for the spring trade, including hair pins, lace pins, scarf pins, brooches and pendants, gold garters, bracelets, lockets, queen chains, etc. One of their most popular designs is illustrated elsewhere, and is probably as handsome a cut of a piece of jewelry as ever adorned a trade journal.

—S. B. Mann, for thirteen years with J. T. Scott & Co., and more recently New York agent of the Rockford Watch Company, has been elected Secretary and Treasurer of the newly incorporated Foley Gold Pen Company, 18 John street, where he will be glad to see any of his friends who are in want of anything in this line. The Foley pen needs no recommendation to the trade, nor does the secretary of the company.

—A syndicate of New York, Pittsburg and Washington capitalists has been organized to open up valuable diamond and gold fields in Western Brazil. They have already obtained concessions from the Brazilian government, and a company with a capital stock of \$2,000,000 is being formed to begin work at once. The company has obtained 50,000 or 60,000 acres of land bordering on the Amazon River, in the region of the Andes Mountains.

—F. P. Locklin & Bro., manufacturers of gold and silver headed canes, have now at 206 and 208 Canal street, this city, one of the largest and most convenient factories for this line of goods we have yet seen. During many years Messrs. Locklins' advertisement has appeared in THE CIRCULAR, and we can say that the qualities of the goods manufactured by them have given perfect satisfaction. Their illustrated catalogue will be sent free to the trade when desired.

—The "Ideal" button, advertised in our pages, rests on a comprehensive and well-established patent. In October, 1886, Judge Wallace, of the United States Circuit Court, rendered a decision in its favor after exhaustive testimony had been taken and able arguments heard on both sides. It is made for the sleeve, the collar and the back of the neck, and houses that have sold the "Ideal" recommend it in the highest terms.

—J. W. Richardson & Co., of 196 Broadway, are beginning the year with the determination to retain firmly the place they have so long held as leaders in their specialty, as manufacturers of emblems of every imaginable kind. Societies of all kinds, from the Free Masons down, can find their emblems and badges illustrated in the beautiful catalogue which Richardson & Co. publish, and send whenever requested free to the trade. The principal jobbers in the large cities will supply their retail customers with this catalogue. The quality and finish of the goods manufactured by this house cannot be surpassed.

—Frasse & Co., manufacturers of watchmakers' tools, machinery, etc., 92 Park Row, will issue a catalogue on Feb. 15th, which dealers can have upon application.

—The flag was at half mast at the factory of the New York Standard Watch Co., in Jersey City, Saturday, January 5th, out of respect to Chas. V. Woerd, of Waltham, one of the pioneers in watch-making in America, who died while traveling for his health on the Pacific coast.

—R. T. Clay, of New York, promoter and inventor, is endeavoring to interest the business men of Easton, Pa., in the project of starting a clock factory there, to manufacture on patents which he holds. He wants \$300,000 from the citizens, \$100,000 of which sum he will take as his interest for the patent.

—The Dueber Watch Case Company have moved their engraving shop at No. 119 Nassau street to the main factory at Canton, Ohio, whither many of the engravers in their employ will go to reside. It is understood to be Mr. Dueber's intention to centralize all his vast enterprises in the thriving little Ohio city.

—The firm of A. Luthy & Co., manufacturers of fine diamond jewelry, corner Ann and Nassau streets, has had a valuable accession to its membership in the person of David Kaiser, who has represented L. Strasburger & Co. on the road for over 20 years, and is known from Maine to California. The firm name has, therefore, been changed to Lewis, Kaiser & Luthy, F. W. Lewis, the senior member, having been a partner with Mr. Luthy for the past year. All three gentlemen are popular with the trade, and have the advantage of a wide experience, and the new firm is sure to get its full share of business.

—The Chas. D. Pratt Co., importers of jewelers' fancy goods, 33 Chambers street, are well pleased with the results of the season's business. Jewelers are finding out that the stock of this enterprising concern is a veritable treasure-trove for them, and, as a consequence, the Chas. D. Pratt Co. do not find themselves burdened with surplus stock at present. Members of the trade visiting New York will be cordially welcomed there to an exhibit which has no equal in this line, and from which they cannot fail to get many new ideas of great value to them in replenishing their stocks and making their stores more attractive.

—The enterprising young firm of Lewis Bros., artistic workers in silver, 41 Maiden Lane, are preparing a very handsome line of novelties for the spring season. Their new designs in watch cases, in applied gold and silver, chased or etched work, are by far the best they have ever shown, and will add further to their reputation for original and artistic work. Manufacturers and dealers should be cautioned against infringing on the patent watch case stiffener illustrated in their advertisement. This is a very desirable thing and is rapidly becoming popular, but Lewis Bros. issue no licenses to manufacturers and have the sole right to make them.

—The Julius King Optical Company, Cleveland, O., propose at intervals during the year to give a series of lectures on the eye, each course to occupy one week, and to afford instruction in the best methods of detecting and correcting the different errors of accommodation and refraction, and the focusing, coning and manufacture of lenses. The lectures will be fully illustrated by the use of charts and models, to make them plain and readily understood, and on the afternoon of each day the class will have an opportunity to do *practical work* in fitting eyes. Every evening there will be a quiz, consisting of a review of the work of the day. This course will be of great practical benefit to the retail jeweler who wishes to learn to fit glasses accurately, and those who contemplate taking such a course of study should write for further particulars to the Julius King Optical Company, Cleveland, O., or 4 Maiden Lane, New York.

—The old established firm of C. Rosswog & Son, 5 Maiden Lane, failed on the 25th ult., judgment having been confessed to Mrs. M. E. Rosswog, wife of the senior member of the firm, for \$16,227. The sheriff was immediately put in possession of the premises under an execution of this judgment, and as the report spread through the Lane attachments came in thick and fast, until a total of about \$20,000 was reached. When the sheriff took possession very little stock could be found, and Mr. Rosswog's explanation of this is that he recently lost a satchel containing several thousand dollars' worth of diamonds on the elevated road. The attaching creditors are therefore likely to realize very little on their claims. The firm has been in business more than 35 years and bore a good credit, but of recent years the illness of the son and the advanced age of the senior member caused a falling off in business that led to a final collapse. Much sympathy is expressed for Mr. Rosswog in the trade.

—See Carter, Sloan & Co.'s "unique" advertisement on page 87.

—George Rodgers, San Jose, Cal., has made an assignment to F. M. Levy.

—J. M. Irmen & Co., Atlantic, Iowa, have opened a branch store at Anita, same State, and are said to be doing well there.

—Another suit has been filed by Royal E. Robbins and T. M. Avery against the Aurora Watch Company, for infringement by the latter's pendant set movements.

—We acknowledge with thanks the compliments of Carter, Sloan & Co. and George O. Street & Sons, tendered in the form of neat and substantial calendars for '89.

—Prindle & Russell, attorneys, of Washington, whose advertisement appears on another page, have for many years made a specialty of patents and patent causes, particularly in the watch and jewelry line, and are therefore in a position to give satisfaction to members of the trade desiring counsel of this sort.

—Vallentine & Co., importers of diamonds, 69 Nassau street, have just received a large lot of melee, suitable for manufacturers' use, which, on inspection, will be found both desirable and cheap. Having direct connection with Kimberley and London, they are in a position to take advantage offered by the market.

—In the recent discussion on the Senate Tariff Bill, the proposed advance of the duty on pearls from 10 to 25 per cent. was rejected; it was proposed to raise the duty on jewelry, including mounted diamonds, from 25 to 40 per cent., and that on gold watches and all parts thereof from 25 to 40 per cent., *ad valorem*.

—The prospects of the Chicago Horological Institute are very bright. Their workroom is now complete, and letters of inquiry are coming in from all parts of the country. THE CIRCULAR takes pleasure in recommending all who contemplate a course in watchmaking to open a correspondence with the Chicago Horological Institute.

—George Smith Rice, for nearly twenty years representative of the Wilcox Silver Plate Company, and one of the most popular travelers in the silver plate line, has severed his connection with that company, and will henceforth be found at the New York store of the Gorham Manufacturing Company, where he will be glad to welcome his many friends from the North, East, West and South.

—We are glad to know that the affairs of Fred. I. Marcy & Co., are about settled, and that Mr. Marcy is again visiting his trade. He will look after the home trade, including Boston, New York, Philadelphia and Baltimore, while Chas. E. Medbury will attend to the Western trade. They are showing some very handsome new designs, which, coupled with his personal visitation, have brought very encouraging results.

—A new company, called the Brettner & Moscovitz Jewelry Manufacturing Company, has been incorporated by Joseph Moscovitz, Henrietta Brettner and Rudolph Brettner, to engage in business at No. 64 Nassau street. The capital stock is understood to be \$10,000. Rudolph Brettner failed recently, it will be remembered, and was arrested immediately thereafter on complaint of D. L. Van Moppes, of whom he had obtained \$1,625.50 worth of diamonds just previous to his assignment.

—Koch & Dreyfus, New Orleans, La., are selling out preparatory to removal to New York, and are offering at greatly-reduced prices their line of tools, materials, findings, jewelry boxes, clocks, canes, umbrellas, optical goods, silver plated ware, etc., which must all be closed out by April 1st. Catalogues of these goods will be sent on application. Their stock of diamonds, watches and jewelry will be kept up to its usual standard during the preparations for removal, and the regular business will not be interfered with.

—The inviolability of design patents has received additional support in the decision of Judge Coxe, in the case of Henry Untermeyer *vs.* Max Freund, *et al.*, for infringement of the well-known star design on watch cases manufactured by Keller & Untermeyer. In his opinion the judge draws a parallel between this case and that of Miller Bros. *vs.* D. Wilcox & Co., recently decided in favor of the plaintiffs, and sums up the gist of the whole question as follows:—"The policy which protects a design is akin to that which protects the works of an artist, a sculptor or a photographer by copyright. If a design produces a different impression upon the eye from anything which precedes it, if it proves to be pleasing, attractive and popular, if it creates a demand for the goods of its originator, even though it be simple and does not show a wide departure from other designs, its use will be protected." Infringers will be prosecuted, and imitated cases should be returned at once to those of whom they were purchased.

—Mrs. M. E. Morton, of Greenville, Ky., gave up business on January 1. She had to give up the house she occupied on that date, but if she can find a suitable place, she will open another store.

—J. F. Fuller, Los Angeles, Cal., and his son-in-law, Jaxtheimer, an optician of the same place, were arrested recently, the first for conveying property with intent to defraud, and the second for receiving the same. Before the holidays the representative of a San Francisco jobbing firm sold him a bill of goods, after looking up his status, and finding it satisfactory. He bought heavily and then made an assignment, with only about \$2,500 worth of stock in sight.

—Arthur Wadsworth, a prominent watchmaker of Newark, N. J., and once interested in the defunct Keyless Watch Company, died recently of paralysis of the brain, aged 67 years. He was skilful at his trade, and at one time possessed of considerable means, but the failure of a number of manufacturing enterprises in which he embarked, had wasted his resources. He has several sons engaged in the watch or case business, one of whom is a foreman for the Dueber Company.

—The firm of Saunders, Ives & Co., 26 Maiden Lane, dissolved by limitation on January 14th. Albert Crouse has retired from the firm to take charge of the diamond department of Max Freund & Co. The remaining partners, John F. Saunders and Chauncey Ives, will continue together pending settlement, but Mr. Ives intends to retire from the diamond business next summer, when Mr. Saunders will succeed to the substantial trade and honorable name of the firm, and continue at the old stand.

—The manufacturers of gold goods and others who sold to the retail trade, enjoyed a good demand close up to Christmas. Kent & Stanley, Howard & Son, the Sterling Company, Ostby & Barton, and Foster & Bailey may be mentioned as among those having a very large fall trade. There are especial reasons for the good trade in nearly every one of these cases. For instance, Kent & Stanley have a monopoly of a certain kind of seamless wire for making watch chains. They also sell direct to the retail trade. The result has been that they have employed 150 hands, and their shop in the top of the new Enterprise building has been lighted up far into the night. The large houses have generally prospered, but with the smaller concerns the year has been decidedly unsatisfactory. The drift of opinion is that concentration of capital and effort will prove more successful than the present system of small shops and large expenses.—*Providence Journal*.

—Andrews' Diamond Palace, San Francisco, Cal., has just been undergoing a thorough renovation, and is now said to rival in splendor the fairy scenes of the "Arabian Nights." Crystal mirrors set in mountings of gold leaf and ebony form the walls, reflecting and bewildering at every angle. The gracefully arched and molded ceiling, with sixteen panels, is a work of art. The panels contain pictures from the artistic brush of E. Tojetti, and in a central one, representing Venus and Cupid, he fairly excelled himself. Other subjects include King Ahasuerus in royal robes and glittering crown of real diamonds; Delilah, Queen Esther, Rebecca, Deborah, Jephtha's Daughter, who sacrificed herself for her father's vow, real gems glittering from neck and crown and shapely fingers, while Moorish characters and Turkish beauties are interspersed in order to heighten the effect of historical and biblical subjects. This magnificent store is one of the sights of the Golden Gate which no visitor should miss.

—The firm of Ludwig Nissen & Co., importers of diamonds and manufacturers of diamond jewelry, No. 18 John street, was dissolved by limitation on December 31st. Mr. Schilling has retired, and a new firm, composed of Mr. Nissen and Alex. C. Chase, has been formed without change of name. Mr. Nissen, who was a butcher by trade, joined Mr. Schilling in the diamond business in 1881, the firm name being Schilling & Nissen; and in two years and a half so indispensable had he become that his partner's name disappeared from the sign, and Ludwig Nissen & Co. succeeded Schilling & Nissen. From that time forth the growth of the business under Mr. Nissen's able management has been steady and rapid. Mr. Chase, the new junior partner, is one of the best-known salesmen in the trade. He was brought up with the house of Baldwin, Sexton & Peterson, and, at the early age of 18, took their line out on the road. After remaining with them eight years, he left to take a similar position with Thos. W. Adams & Co. For eight years he represented them on the road, returning eventually to Sexton Bros. & Washburn, the successors of his original employers, Baldwin, Sexton & Peterson, and resigning his position there at the beginning of the New Year to go into partnership with Mr. Nissen. If industry, reliability and popularity can win success, these two gentlemen have it assured them.

—Otto Woiff, formerly with Alling & Co, will represent Bruhl Bros. & Co. in New York and vicinity for the coming year.

—Retailers who are curious about the "Royal" initial ring, advertised on another page, can obtain all desired information by addressing THE CIRCULAR or through the nearest jobber.

—The Non-Magnetic Watch Co. are about to place on the market a line of 18 size full plate movements of American make, containing Pailard's balance and hair spring and non-magnetic escapement.

—Howard & Moehle, refiners and assayers, 8 John street, have dissolved partnership. S. P. Howard will succeed to the well established trade built up by the old firm, and will continue at the same place.

—Consul Erhard Bissinger, at Beirut, Syria, kindly remembered THE CIRCULAR with a card bearing New Year greetings. On behalf of the trade with which he was so long and honorably connected, we return the felicitations of the season.

—Aikin, Lambert & Co. are very busy in their pen and pencil factory getting out their new goods for spring trade. In their other departments they are offering special bargains in Swiss watches, discontinued American movements and jewelry.

—The jewelry store of Charles Mills at Brocton, N. Y., was broken into on the night of the 20th, by a man named Banks. He was arrested and brought to Mayville and lodged in jail, where 37 watches and other articles of jewelry were found on his person.

—J. B. Wood, representing Charles F. Wood, importer and incrufter of precious stones, started for Europe on the steamer *Champagne* on the 26th ulto., to purchase a season's supply of diamonds and gems for the needs of Mr. Wood's constantly increasing business.

—The year's business of the R. Wallace & Sons Mfg. Co., Wallingford, Conn., was the largest in the history of the concern. Their fine three story factories, covering over an acre of ground, were pushed to the fullest capacity to meet the demand for their well-known sterling and silver plated ware.

—Victor Nivois, late manager of the New York engraving shop of the Dueber Watch Case Co., has started a watch case factory in Newark, to manufacture both gold and filled cases. The enterprise is said to be backed by sufficient capital to meet all requirements, and Mr. Nivois' ability as an engraver and foreman is universally recognized among the trade.

—Henry Horwitz, formerly manager of the diamond department of Stern Bros. & Co., has just returned from Europe after having made a connection with some of the leading cutting establishments of Amsterdam, and has opened an office at No. 17 Maiden Lane, where he will carry a stock of loose diamonds, replenished by regular shipments from the other side.

—Lawson & Van Winkle, successors to Samuel Lawson, No. 11 Maiden Lane, are making a line of enameled flower scarf pins, bonnet pins, ear rings, etc., which all using this popular style of jewelry should see. They also carry a full line of black onyx goods, and are among the few in this country who are prepared to make coral jewelry or repair it equal to new.

—Rodolf Reinhart, of Amsterdam and Paris, has opened an office at No. 17 Maiden Lane, where he will keep constantly on hand a large stock of loose diamonds. Mr. Reinhart, who is well known in the principal cities of Europe, desired to extend his business to the western continent, and his experience and valuable foreign connections will doubtless stand him in good stead here.

—A. Lyons, agent, 36 Maiden Lane, has on hand a very large assortment of jewelry boxes in plush, morocco and velvet, at prices which he guarantees to be the lowest in the market; also a desirable line of opera glass bags and spectacle cases. Another novelty of his which retail jewelers will find useful is an array of very neat and legible block letter signs in 22 karat gold, and descriptive price tags of the same kind for window display. These are a positive ornament to any jewelry store and can be read at a glance, whereas the ordinary written price marks are with difficulty deciphered.

—We would call attention to the advertisement of A. Alling Reeves, 21 Maiden Lane, successor to the old and well-known house of Isaac A. Alling & Co. The special manufacture of this house is a line comprising several hundred styles in bracelets, bangles, padlock and chain bracelets, diamond mountings and wire goods in both 10 and 14 karat, the styles being peculiarly their own and dissimilar from anything else in the market. Their goods are marked favorites with the best trade in our leading cities. Mr. Reeves will be pleased to send selections to any who may not be called upon by his representatives.

—The engraving of our late esteemed president, Seth W. Hale, which accompanies this issue, is reproduced from a photograph taken some fifteen years ago, and is considered a very good likeness of him as he appeared at that time.

—A. Bechtold, 80 Nassau street, is manufacturing a patent adjustable eye-glass frame, which has undoubted merit and is illustrated elsewhere in this number. These frames adjust themselves to any nose, and relieve the bridge of that much-suffering organ of all tension when the head is moved, or in putting on or taking off the spectacles.

—"How to Fit Glasses" is the title of a 100-page pamphlet recently published by James W. Queen & Co., 924 Chestnut street, Philadelphia, and intended for the use of opticians and jewelers who sell optical goods. It is a handy little treatise, and as it goes into the subject quite thoroughly, it will be found useful to the increasing number of jewelers interested in this subject.

—S. F. Merritt, Springfield, Mass., the well-known manufacturer of eye-glass chains, etc., has invented a very simple but ingenious machine for cutting solder for jewelers' use, which will prove a valuable addition to the factory equipment of any manufacturer. Only two pairs of rolls are needed to cut solder of any size that may be used in the shop. The machine does not get out of order, and with it one man can cut enough solder in an hour to last ten chainmakers a week. It is specially desirable when solder is to be cut of uniform size or shape. Here is a chance for the manufacturers to save time and trouble, which in this age is everything.

—William Evans, 377 Eighth avenue, New York, disappeared on New Year's Day, leaving little behind him except \$5,000 of liabilities. All the valuable goods are missing, and as he was seen carrying away a large valise on the day in question, it is supposed that he has gone to Canada. He began business there in April last, buying out H. Ader for about \$2,000. He said that he had previously been in business in London, but nothing definite was known regarding his antecedents, and he failed to establish a good credit. Not long before the holidays he obtained goods on memorandum, and on credit from various firms, making representations that he had \$10,000 in stock free and clear, and was not indebted to anybody. Schafer & Egenberger, of 69 Nassau street, who sold him some goods, have gotten out an attachment against him, declaring that his statements were false and that he has left the State to defraud his creditors. The sheriff is in possession of the store.

—B. & W. B. Smith, of 220 West 29th street, New York City, have brought the production of showcases to a fine art. It has always been the aim to make counter cases with as small a frame or moulding as would be consistent with durability and strength. But to use $\frac{1}{4}$ inch plate glass and have a moulding $\frac{1}{2}$ inch in diameter has heretofore been impossible. Now, thanks to the inventive genius of the Messrs. Smith, that result has been reached. They make a counter case 6 to 10 feet long, 18 inches high and 28 wide (or any size), of single lights $\frac{1}{4}$ inch plate glass, with a rosewood, mahogany, walnut or cherry frame $\frac{5}{8}$ inch thick. They make smaller cases for exhibition of specialties and for windows, with hardwood frame, only $\frac{3}{16}$ of an inch in diameter. Their show room is like a museum, and their new illustrated catalogue which will shortly be issued will be both artistic and interesting to the trade, containing original designs in wall and counter cases, tables and window novelties, and forming a book of about 75 pages.

—On the evening of the 8th of January a number of the friends of A. Barker, the veteran representative of the Meriden Britannia Co., gathered at his residence in Meriden to celebrate the 20th anniversary of his connection with the company in the capacity of traveling salesman. In January, 1869, Mr. Barker started in to drum the silver plated ware trade for the Meriden Britannia Company. During that 20 years he has had a rich and varied experience. He has been many times near death's door, had narrow and even hairbreadth escapes on rail and boat, but has steadily climbed the hill of his profession, until no man to-day who goes out of Meriden to sell goods can show a better record or bring in greater returns to the company. Music, story-telling and other social pleasures filled the evening, one of the most notable features being a well-written poem entitled, "The Tints of Twenty Years," which was read by the author, John W. Miles, of the New York store. A curious coincidence was the fact that there were just 20 guests present, as follows: H. C. Wilcox, George R. Curtis, W. W. Lyman, I. C. Lewis, Marshal Forbes, Clarence H. Fisk, Geo. E. Savage, John Milroy, E. E. West, H. A. Stevens, P. A. Spencer, H. W. Hirschfeld, John Jepson, Oliver D. Swan, Geo. C. Foote, John W. Miles, of New York, James P. Williams, W. H. Stannis, John M. Harmon, and G. G. Tibbals, of Durham.

TABLE OF CONTENTS.

Atlanta and the South.....	83	Cincinnati Letter.....	74	Lathes and Lathe Work.....	33	Pearls at the Berlin Exhibition.....	34
Attleboro and vicinity.....	69	Chimes.....	80	London Letter.....	29	Paris Letter.....	39
Berlin Exhibition, Pearls at the.....	34	Detached Lever E-escapement, Problems in.....	72	Magnetism, How to Test for. By "Excelsior".....	53	Providence Notes.....	41
Boston Letter.....	56	Escapements, The Different.....	79	Marfels Watch Collection (illustrated).....	62	Philanthropy, Practical.....	48
Board of Trade, Fourth Annual Meeting.....	57	Fashions in Jewelry.....	42	Mechanical Ocular Defects.....	26	Recent Patents.....	66
Canine Lace Smugglers.....	33	Foreign Gossip.....	83	Minute Wheel and its Stud.....	71	Ring of the Hohenzollerns, The.....	80
Carpet, of Diamonds and Pearls, A.....	47	Galvani, Luigi.....	77	Obituary—Elias Morris, William J. Miller, Dwight H. Buell, Samuel H. Cowell.....	30	Scapewheels of Swiss Watches.....	80
Clocks as Ear Pendants.....	48	Gossip of the Month.....	21-25	Opal, The.....	79	Tower Clocks.....	78
Chicago Letter.....	69	History of Watch and Clock Making.....	61			Trade Gossip.....	87-92
Commercial Honor.....	25	Jewelers' Security Alliance.....	74			Workshop Notes.....	84
Communications.....	73	Jewelers' and Tradesmen's Company.....	78				

INDEX TO ADVERTISERS.

Abry, Chas. Leo.....	68	Fidelity Watch Case Co.....	35	Mendes, D. DeSola & Co.....	27	Simpson, Hall, Miller & Co.....	59
Aikin, Lambert & Co.....	68	Fisher & Sons.....	40	Merritt, S. F.....	16	Smith & Knapp.....	35
Albro, S. & Co.....	Outside back cover	Floyd, Pratt & Rounds.....	59	Middletown Plate Co.....	10	Smith, Alfred H., & Co.....	23
American Watch Tool Co.....	3	Fox, M. & Co.....	96	Miller Bros. & Co.....	52	Smith B. & W. B.....	outside back cover, 93
American Waltham Watch Co.....	18-50	Frasse & Co.....	46	Montgomery & Co.....	103	Smith, H. M. & Co.....	60
Ansonia Clock Co.....	1	Freund, Max & Co.....	85	Moore & Horton.....	45	Smith, Lesquereux & Co.....	49
Anti-Magnetic Shield & Watch Case Co.....	12	French, J. H.....	40	Myers, S. F. & Co.....	52	Special Notices.....	97
Atkinson Bros.....	45, 75	Friedlander, R. & L.....	14	New Haven Clock Co.....	35	Spencer Optical Mfg Co.....	7
Austin, John & Son.....	13	Glatz, Charles.....	36	Newman, Louis, Jr.....	103	Sterling (The) Company.....	4
Bates & Bacon.....	8	Gorham Mfg. Co.....	20	New York Standard Watch Co.....	63	Stern & Stern.....	14
Bartholomew & Peckham.....	103	Haskell, H. C.....	60	Nicholson File Co.....	46	Strasburger, Louis & Co.....	16
Bechtold, A.....	11	Hausburg, O. E.....	103	Nissen, Ludwig, & Co.....	85	Sussfeld, Lorsch & Co.....	28
Bennett, Jacob's Sons.....	76	Hedges, Wm. S. & Co.....	82	Non-Magnetic Watch Co.....	89	Tannenbaum, L & Co.....	28
Birch, John S., & Co.....	96	Hoffer, A.....	81	Nye, Wm. F.....	94	Taylor & Bro.....	27
Blancard & Co.....	46	Howard, S. P.....	Outside back cover	Odenheimer & Zimmern.....	104	Ternandt, F.....	103
Bookhout Bros.....	103	Imhauser, E.....	103	Oliver, W. W.....	94	Thomas, Seth, Clock Co.....	Inside front cover
Bowden, J. B., & Co.....	76	Ingersoll, R. H., & Bro.....	46	Oppenheimer Bros. & Veith.....	49	Thrall, Edwin A.....	67
Briggs, J. & Sons.....	13	Irons, Chas. F.....	Inside back cover	Oppenheimer, Henry E. & Co.....	61	Towle Mfg Co.....	49
Brooklyn Watch Case Co.....	17	Jacques, Charles.....	6	Owen, G. & S., & Co.....	28	Trenton Watch Co.....	90
Brown, Thomas G., & Sons.....	27	Jeanne, Leon P.....	36	Pairpoint Mfg Co.....	11	Troemner, Henry.....	103
Buhler & Nanz.....	75	Jeannot & Shiebler.....	31	Percival, D. C., & Co.....	39	Valentine & Co.....	67
Bynner, T. B.....	103	Kahn, L. & M. & Co.....	104	Peterson & Royce.....	75	Valuable Instruction Books.....	Inside b'k Cover
Carter, Sloan & Co.....	51	Keller, L. H. & Co.....	96	Pforzheimer, Keller & Co.....	28	Wallace, R., Sons Mfg Co.....	36
Cattelle & Decker.....	75	Kendrick & Davis.....	39	Plainville Stock Co.....	39	Want, Edwin.....	12
Chalmers-Spence Co.....	60	Kent & Stanley.....	60	Platt, Chas. S.....	Outside back cover	Washburn & Moen Mfg. Co.....	103
Cheever, J. G. & Co.....	32	Ketcham & McDougall.....	11	Prindle & Russell.....	67	Watchmaker, Jeweler and Silversmith.....	96
Chicago Horological Institute.....	14	Koch & Dreyfus.....	19	Randel, Baremore & Billings.....	86	Waterbury Clock Co.....	1
Clark, A. N.....	46	Kohlbusch, Charles.....	103	Riley, John A.....	59	Waterbury Watch Co.....	24
Columbus Watch Co.....	40	Krementz & Co.....	93	Robert, J. Eugene, & Co.....	85	Welch, E. N., Mfg Co.....	Inside front cover
Combremont, L.....	12	Lady Racine Chatelaine Watch.....	32	Rogers & Bro.....	9	Western Clock Mfg. Co.....	76
Conover, D. F. & Co.....	6-15	Lawson & Van Winkle.....	12	Rogers, Smith & Co.....	10	Wheeler, Hayden W. & Co.....	67
Cooke, B. J's. Sons.....	76	Lelong, L. & Bro.....	Outside back cover	Russell, Chas. A. & Co.....	Inside back cover	Whiting, F. M. & Co.....	19
Cross & Beguella.....	15	Loehlin, F. P., & Bro.....	52	Russell, Irving L.....	60	Wiesbauer Mfg. Co.....	90
Crouch & Fitzgerald.....	Outside back cover	Logan, A. J.....	95	Sauter, L. & Co.....	28	Wiggers & Froelick.....	Inside Back Cover
Cuppla, L. A.....	76	Lorsch, Albert, & Co.....	Outside back cover	Schleicher, Schumm & Co.....	45	Wilkinson, C. B.....	103
Ditshelm, Hipp.....	27	Lowell Wrench Co.....	12	Scott, J. T. & Co.....	52	Woglom, Gilbert T.....	45
Downing, Keller & Co.....	28	Mathey Bros., Mathez & Co.....	16	Sexton Bros. & Washburn.....	40	Wood & Hughes.....	27
Evans, W. F. & Sons.....	40	Manhattan Watch Co.....	32	Sheaffer, W. H., & Co.....	27	Wood, Chas. F.....	67
Fab'r, Eberhard.....	46	McCall & Newman.....	45	Shiebler, George W.....	31	Wood, J. R., & Son.....	103

THESE GOODS
ARE OF
AMERICAN
MANUFACTURE,

AND OF THE
NEWEST
STYLES.

STEEL AND NICKEL

SPECTACLES AND EYE-GLASSES,

D. F. CONOVER & CO., PHILADELPHIA.

SEND
FOR
PRICE LIST.

PRICES
FROM
\$10.50 Gross up

NEW SAMPLES OF ONYX CLOCKS AND SIDE PIECES.

We beg to inform the Trade that we have received our samples of Onyx and Marble Clocks and Side Pieces, and respectfully invite buyers to inspect same.

Special Rates given for Import Orders.

CHARLES JACQUES.

SPECIALTY OF CLOCKS.

"ONYX," "MARBLE," "BRONZE," "CRYSTAL," "ROYAL WORCESTER," "SEVRES,"
"FAIENCE," "CHIMING AND CUCKOO" CLOCKS.

2 Maiden Lane,

NEW YORK.



VOLUME XX.

NEW YORK, MARCH, 1889.

No. 2.

THE JEWELERS' CIRCULAR

AND

HOROLOGICAL REVIEW.

OFFICIAL REPRESENTATIVE OF THE JEWELERS' LEAGUE, THE NEW YORK JEWELERS' BOARD OF TRADE, AND THE JEWELERS' SECURITY ALLIANCE.

It is also the Recognized Exponent of Trade Interests.

A MONTHLY JOURNAL DEVOTED TO THE INTERESTS OF WATCHMAKERS JEWELERS, SILVERSMITHS, ELECTRO-PLATE MANUFACTURERS, AND THOSE ENGAGED IN THE KINDRED BRANCHES OF ART INDUSTRY.

SUBSCRIPTION.—To all parts of the United States and Canada, **\$2.00 per Annum**, Postage Paid. To all Foreign Countries, **\$3.00 per Annum**, Prepaid.

All communications should be addressed to

THE JEWELERS' CIRCULAR PUBLISHING CO.,
189 BROADWAY, NEW YORK.

Advertising rates made known on application.



A full Index to Advertisements and Table of Contents will be found on Page 5 of this issue.

A NUMBER of progressives in the trade are advocating the adoption of the decimal system of computing diamond weights. The idea already has quite a following and seems to be gaining new adherents constantly. Of course, objections are raised against it, but they do not differ from those brought against all reforms and resolve themselves chiefly into this—the difficulty of securing unanimity and the trouble involved in making the change. This is but faint opposition, however, and cannot stand against the bona fide arguments and continual agitation of the friends of the reform. Indeed, few of its opponents deny that it would simplify calculation and decrease the liability to error, but these advantages, they say, would not compensate them for the inconvenience attending the adoption of a new system. Say the more reasonable of the conservatives: "Your idea is good. Your reasoning is sound, but what you aim at can never be accomplished. It is impracticable;" failing to see their own inconsistency in admitting the practicability of the thing and denying it in the same breath, for there is no antagonism between sound reasoning and practice. These are ever the arguments that meet the reformer. What are they worth on analysis? So far as unanimity is concerned, who ever heard of unanimity on the first propounding of

a radical reform? Nor is the second part of this dual objection a whit sounder than the first. In the progress of the human race from barbarism to its present state of civilization every step has been attended with trouble. The shackles of false and weak systems and old cramping methods have been struck off, to the great discomfort and pain of the enyved limbs had long been accustomed to them. But has not every struggle of transition been followed by the triumph of freer use and enjoyment? It is true the reform under consideration may seem trivial in comparison with the great trend of human destiny, but the same principles apply to it, and the same eagerness to embrace truth and rational improvement that characterizes the progressive scientist, inventor and political economist, must characterize the progressive business man. Every question that presents itself should be considered solely on its merits, with the assurance that truth will invariably prevail against all the indifference or open attacks of prejudice. If the proposed change to the decimal system will economize time and lessen the liability to error, and the objections raised against it are no stronger than those already offered, then it ought to be introduced; nay, we can go further and say it will be introduced. But while the subject of reform in diamond computation is under discussion, there is another matter of prime importance that should receive a share of attention, and that is the uniform karat. At present much confusion prevails, particularly on this side of the Atlantic, in reference to the true karat weight, the makers of jewelers' weights having adopted varying standards as the basis of their scales. This confusion is entirely unnecessary and exists only because it has never been seriously investigated. Shortly before the sale of the French crown jewels a syndicate of Paris, Amsterdam, London and Antwerp diamond dealers adopted the karat of 205 milligrams as their standard, and this is the recognized standard abroad. All that is necessary to make it universal is that the diamond and precious stone dealers on this side of the water should unite and adopt the same standard. Then we will have what is of equal or greater importance than the decimal notation—a uniform standard karat. The interest that is now aroused should not be allowed to wane until both of these desired reforms have been accomplished.

*
* *

*
* *

*
* *

IN SPITE of "the law's delay" and "the insolence of office," the assignment of Payne, Steck & Co. has been set aside, owing chiefly to the assiduity and adroit management of Franklin B. n, counsel for the creditors. The judicial verdict thus sustains the opinion prevalent among the entire trade as to the failure, and paves the way with a good precedent for the criminal prosecution, which a vivid imagination might just discern in the dim distance with the aid of a powerful microscope. But, unfortunately, so far as good precedents or good intentions are concerned, the District Attorney's office bears a striking resemblance to that torrid region which is said

to have a pavement composed of second-hand material of this sort. But however justly we may complain of dereliction in this quarter, the attitude of our courts toward fraudulent bankruptcies, as evidenced by decisions in the last three years, should give satisfaction to the trade and teach a wholesome lesson to evildoers. There is a plain disposition to deal less leniently than formerly with this class of offenders against commercial honor. This is due partly to the good work of the commercial agencies and our own Boards of Trade, and still more, perhaps, to the increasing stress of competition, which, as a matter of self-preservation, requires a more careful scrutiny of the profit and loss account. One of the greatest impediments to reform in this direction is the laxity of our public prosecutors, who, as a rule, are part and parcel of the political machines and are under obligations to them for their election, and consequently have large perquisites to make. Under such circumstances delays and even default of justice are to be expected. But the day is not far distant when the Augean stable of politics will be purified. It is well nigh certain that a ballot reform bill will be passed in this State within the next year or two, and the Australian ballot means inevitably better government, more honest judges and more zealous public prosecutors. It is also patent that the very intensity of competition will compel merchants to weed out of their ranks the rampant rascals and the declared swindlers. In a future issue we may tell how we think this weeding process can best be done.

* *

* *

* *

"EXCELSIOR'S" "How to Test for Magnetism," etc., on another page, is worth a year's subscription to any watchmaker.

* *

* *

* *

MR. FREDERICK Schober, Secretary of the National Watch Case Company, 715-717 Arch Street, Philadelphia, relates a very good story which illustrates admirably the the extreme punctiliousness of the old Quaker stock of that city. An aged, sombre-looking individual belonging to that sect came into the company's office recently and asked of him, "Is thy name Schober?"

"Yes."

"Frederick Schober?"

"Yes."

"What was thy father's name?"

"Samuel Schober."

"Is he living?"

"Yes."

"Did thy father once keep a queens'vare store on Market street?"

"Yes," said Mr. Schober, "but that was many years ago. And now that you have had your turn as inquisitor, let me ask a few questions. What is the object of all this inquiry into my genealogy?"

"Well," continued the Quaker, "in 1851 I bought a spittoon of thy father, and the price was 32 cents, but I happened to have only 30 cents with me at the time. Thy father said it was no matter, but I told him I would bring the two cents around. Time passed, I moved to another quarter of the city, the panic of 1857 left me penniless as it did everybody, and I failed to keep my promise. Some months ago I was turning over some old memoranda and came across the item where I had jotted it down many years before. I did not remember thy father's name, and supposed he was dead, but I determined to hunt up the heirs and pay them as I did not owe another cent in the world. Two cents compounded every ten years would amount to, in round numbers, 32 cents. Here is thy money."

Mr. Schober could not repress a smile, and as for the employees of the office, they sought refuge behind desks and safes to hide their laughter. The old Quaker left with the proud consciousness of a man who has done his full duty, and Mr. Schober when he returned home at night handed the conscience money to his father, whose

astonishment and merriment over the ultra-scrupulousness of his old customer can well be imagined. We should add by way of caution, that the old Quaker was not in any way connected with the jewelry business, and that such instances of the refinement of commercial honor are said to be rare even in the city of Brotherly Love. It would, perhaps, be as well, therefore, not to extend Philadelphia credits on the strength of this anecdote.

* *

* *

* *

THE custom of "tipping" buyers or subordinates in order to gain readier access to buyers has become too common in the jewelry as in other trades. Salesmen, not over-scrupulous about the niceties of business ethics, consider it a smart way to score a point on a competitor, and it must be confessed that the buyers, themselves, do not, as a rule, offer any very strenuous resistance to the covert dole and fee. It is a practice that should be denounced and discouraged, however. It warps the buyer's judgment and predisposes him to favoritism, yet he has it in his power to repel all advances of this kind if he only wishes to do it. Not long ago the gentleman who acts in that capacity for a prominent New York house did "discourage" it in a manner at once so dignified, and so crushing, that we rehearse the story in the hope that his example will be imitated. The buyer in question, who is a man of few words and multifarious duties, had picked out a liberal selection from the salesman's sample case, was about to turn his attention to the next comer when the salesman probably overcome with a sudden gush of generosity, said: "By-the-way, Mr.—, I should like to see you wearing one of our rings; take your pick from the case." The buyer took one without replying, and was then called away for a few moments, but on his return he laid out a few more goods. The salesman, elated at the apparent success of his little stroke of diplomacy, was surprised and abashed when, without change of tone, his customer said: "By-the-way, how much did you say this ring was worth?" "Eighteen dollars, to you." "Is that your lowest price?" "Yes." "Well, just credit the amount on the bill, I don't want the ring." The salesman sank into his boots, and it is doubtful whether he ever resorted to tipping again to gain a point on his competitors. There was a volume of advice and rebuke for him in those few words. He paid just \$18 for his experience, but it was cheap at that for it ought to last him a lifetime.

* *

* *

* *

Chas. S. Crossman's interesting articles on the history of the watch case and clock industries of the United States will run for two years more.

* *

* *

* *

A RATHER remarkable state of affairs exists in Bellaire, O. according to the *New York Times*. About a month ago, in the face of considerable opposition on the part of a portion of the citizens, the local Board of Education determined to change to city time,—from "sun" to Eastern standard—and having control of the City Hall clock, the hands were swung around accordingly. The result was a clamor which was reflected in the Council, and after a great deal of lung power had been expended and columns had been wasted in the local press, the Council passed an ordinance making it a misdemeanor for any one to expose a timepiece in public with the hands marking any other than local time. The Board of Education, in solemn session, snapped its fingers at the Council, and recently the last named body determined to enforce the law. The entire Board of Education was then put under arrest. There is great excitement throughout the city and the community is about equally divided. Meanwhile the clock marks standard time. The struggles in certain sections of the country over the adoption of standard time recalls the tribulations of Galileo when he first began to propagate the heretical doctrine that the earth revolves around the sun. The rack and the

thumb-screw have gone out of fashion, but the spirit of persecution still lives. How fortunate it is for us that though ecumenical councils and city fathers get badly mixed up in their astronomy, the planets still remain impassive and neutral and roll on in their destined way.

* * * * *

See the handsomely illustrated serial on the Marfels Watch Collection at Frankfort, on the Main, commenced in the December number.

* * * * *

THE DECEMBER schedule of imports and exports closes the year, and enables us to draw a comparison between the business of 1888 and that of the preceding year.

IMPORTS.

ARTICLES.	VALUES.			
	Month ending December 31—		Twelve months ending December 31—	
	1888.	1887.	1888.	1887.
Diamonds, rough or uncut, including glaziers' diamonds.....	11,011	7,440	296,197	286,072
Platinum unmanufactured.....	35,462	32,673	562,479	508,716
<i>Clocks and Watches, and parts of:</i>				
Clocks, and parts of.....	36,257	28,069	414,555	370,669
Watches, and parts of, and watch materials and movements.....	160,220	127,642	1,713,600	1,590,166
Total.....	196,477	155,711	2,128,255	1,960,835
<i>Jewelry, Manufactures of Gold and Silver, and Precious Stones:</i>				
Jewelry, and manufactures of gold and silver.....	573,296	76,041	1,248,663	953,320
Precious stones, n. e. s., and imitations of, not set.....	573,296	318,086	10,259,049	10,731,524

EXPORTS.

<i>Clocks and Watches:</i>				
Clocks, and parts of	105,077	103,087	1,061,867	1,139,414
Watches, and parts of.....	8,219	40,429	334,000	279,312
Total.....	113,296	143,516	1,395,867	1,418,726
<i>Jewelry, and manufactures of gold and silver:</i>				
Jewelry, and manufactures of gold and silver.....	50,493	45,235	417,293	463,950
Plated ware	40,583	42,707	530,577	585,872

An increase of imports and a decrease of exports, generally speaking, the watch manufacturers being about the only ones in the trade who are keeping their end up in the export business. Rather an enigma to the old style political economist, one would think, considering that this is one of our highest paid branches of skilled labor. None the less is it true, however, and every year proves it more conclusively that the American watch is the best in the world for price and serviceability. Perhaps if other branches gave as much attention to export trade as the watch companies do they might get equally encouraging results.

* * * * *

BY RECENT accounts it appears that about 110,000 Rx. worth of rubies from the Burmese mines were dispatched and insured by parcel post from Mandalay to Calcutta during the twelve months of 1887-88. It is quite probable that the syndicate which recently obtained control of these Burmese mines will double or treble this production the first year, as the unscientific and wasteful methods of the native diggers will be replaced by modern labor-saving appliances, and a stricter supervision will be exercised over the entire work.

* * * * *

Dr. Bucklin's valuable articles on "Mechanical Ocular Defects," a thorough elementary treatise, began in the February number. Subscribe now and have the series complete.

* * * * *

THE PARIS correspondent of a contemporary says that a clever French lady has prepared the following schedule of the world's taste in jewelry: *Oriental*—Beautiful stones; poorly cut and poorly

mounted. *Russian*—Faultless stones; mountings which lack style. The jewelry is rich, but without taste or originality. *English*—Choice stones; mountings beastly and excessively heavy. *German*—Poverty stricken and in bad taste. *Austrian*—Heavier than the English; taste on a par with the German. *Italian*—Has not advanced since the days of Pompeii. *Spanish*—Nothing but votive offerings. *French*—With mediocre stones, a little gold and much taste incomparable jewelry is produced. Commenting on this, the *Watchmaker, Jeweler and Silversmith* says: "However true the above estimate of English taste may be respecting the jewelry formerly turned out by our manufacturers, it is an undoubted libel on their modern productions, which it is just possible the clever lady in question has not had many opportunities of inspecting." And how about American manufacturers? Are they unworthy of a place in the "clever" lady's category? Let the judges of the forthcoming Paris Exposition, her own compatriots, answer.

* * * * *

Call the attention of editors of your local papers to "Elsie Bee's" "Rambles Among the Jewelers," and have the items reprinted. It will increase your trade.

* * * * *

RECENT reports from Brazil and Asia show that the world is not losing interest in the diamond, and that speculators and capitalists are not haunted by any such fear. A syndicate of American capitalists recently obtained important concessions from the Brazilian government with the purpose of developing new diamond fields in the northern part of that country, so marvelously rich in minerals. The old Indian mines have not escaped the prospector's watchful eye, and it is probable that these will ere long be worked more extensively. Some weeks since an expedition visited a portion of the Deccan, where diamonds are said to have been found two or three centuries ago, but met with no encouraging signs. In the South African fields new localities are being discovered from time to time, and still the world hungers for more diamonds. Verily, we know not one-tenth of the mineral resources of the globe we inhabit, nor do we realize how boundless are those desires which, like the whips and stings of a taskmaster, drive us to Mother Earth for their satisfaction.

Commercial Honor.



THE REMARK one hears so frequently to the effect that the race is becoming more and more degenerate and that commercial honor is a thing of the past, would seem to be borne out, in part at least, by the number of persons who annually transfer their residence to Canada or other foreign lands, and the number of bankruptcies that are reported every month. But this is mere seeming, and to ascertain the facts the subject must be looked at relatively to other things. The population is increasing at a rapid rate, and the number of persons engaged in business is increasing proportionately; greater publicity is given to current news than ever before, and every little failure or fraudulent transaction is pounced upon by sensational reporters for the daily press who make the most of it possible. If the facts could be definitely ascertained we confidently believe that they would show that the percentage of rascality to population and capital is less now than it was fifty or one hundred years ago. There have always been and always will be swindlers and rascals who will lose no opportunity to rob their fellow men, and will devote all their time to devising ways and means for accomplishing their purpose, notwithstanding which we believe that the morals of the people, on the whole, are better now than ever before in the history of the race. Also, that the standard of commercial honor was never higher than now, notwithstanding the black sheep in the flock. Merchants and

business men in general regard their good names as above price, and no effort or sacrifice is too great for them to make when calamity threatens to overtake them. Numerous instances of heroic sacrifices might be named, where men have borne heavy financial burdens for years and grown old under the weight of them rather than that their commercial honor should be tainted or suspected. Many such men are in business to-day and bravely fighting for their good name. They might lay down their burden and shift the weight to the shoulders of their creditors, but they prefer to struggle on rather than shirk the responsibility they have assumed or allow a smirch to rest upon their names.

We are led to these remarks by an occurrence that recently came to our knowledge. A firm for many years favorably known to the trade, through events for which the members were in no wise responsible, became embarrassed in business. Their creditors had the utmost confidence in them and in their ability to weather the storm if time were granted. They offered to turn over to them all the property of the firm, but they refused to accept this proposition. The creditors then voluntarily offered to accept fifty per cent. of their claims and release the firm from further obligation if they would continue the business. This arrangement was finally made, and in a short time the fifty per cent. compromise was fully paid by the debtors. But they were not satisfied with this, and would not be contented till they had paid their last creditor dollar for dollar. To this end they worked and labored, exercising the most rigid economy in all things, until finally this object is accomplished, and the full amount of the remitted liability, from which they had been lawfully absolved, is practically liquidated. We regret that the gentlemen will not permit us to use their names in this connection, for the trade should know who it is that has made these sacrifices to maintain their commercial honor. Many in the trade, however, will identify them by means of the circular letters they have sent them enclosing their check for the amount due after the sum on which they had compromised had been paid. Men frequently struggle quietly for long periods with the overweight of their burdens, and make unheard of sacrifices to preserve their honor and their credit, but it is seldom that one who has met the crisis and been legally released from his obligations, voluntarily continues his work till the old score is fully wiped out. The instance we have cited furnishes an example of heroism that reflects honor upon the entire commercial community.

Copyrighted 1888 by Charles A. Bucklin.

Mechanical Ocular Defects.

Their Nature, Cause, Correction and Relations to Functional Nervous Diseases.

EDITED BY C. A. BUCKLIN, A. M., M. D., NEW YORK.

[The aim of the author is to produce a clear and thoroughly practical course of instruction on the subject of "mechanical ocular defects," which is entirely void of useless technicalities and within the easy comprehension of every thinking student, without his having had any previous technical or mathematical education.]



IN OUR LAST it was stated in conclusion that in every case of defective vision one or more of five conditions already described must exist. The question we will now consider is how are we to decide which of these conditions are present. This is done by a systematic experimental method of exclusion, the general outlines of which are as follows:

What is the age of the individual? If below forty presbyopia is not probable; if above forty presbyopia is probably one element in the case at least. It may be the only defect or it may be only one of several existing defects.

Knowing what the average individual should see and having graded letters which represent the average acuteness of distant vision,

the most natural step to take when examining an individual who complains of poor sight is to determine

How much he can see. If he sees distinctly at a distance as well as the average individual should see, you have another point in the method of exclusion from which you draw conclusions; thus

Amaurosis, amblyopia, obscurities of vision, myopia and astigmatism have been excluded from the list of possible defects at a single step. The age of the individual has already answered the question regarding the possibilities of presbyopia. The individual being young we have hyperopia, errors of accommodation and muscular defects left as a possible cause of the visual trouble. The existence of hyperopia is in many cases readily proven by the fact that the distant vision, although perfect without glasses, is not made indistinct by placing before the eyes convex lenses of considerable strength. When they accept convex glasses for the distance the strongest lens through which they can possibly see distinctly the distant test letters measures the degree of manifest hyperopia.

In young individuals the demonstration of the existence of hyperopia is made difficult in this way: The individual adjusts his lens so that it corrects his hyperopia, and when asked to look through convex glasses at a distance he fails to discontinue the adjustment of his lens which corrects his hyperopia; consequently the lenses make distant vision indistinct. Individuals having a hyperopia of $\frac{1}{2}$ or $\frac{1}{4}$ will frequently refuse to see through any convex lenses at a distance. There are two positive ways in which these difficulties in the way of demonstrating the existence of hyperopia in young children can be overcome. The first method is to paralyze completely the adjusting power of the eye by the use of a solution of atropia, one part to sixty of water. Drop this into the eye three times in twelve hours and make the examination with convex lenses on the following day. The hyperope under these circumstances cannot see at a distance till a convex lens is placed before the eye, which completely neutralizes his hyperopia. This method is positive. The temporary effects of the atropia are very annoying to the individual, but in cases of weak vision in young people at the reading distance this method must be used by those who are not very skillful and confident in the use of the ophthalmoscope.

The second method of overcoming these difficulties is the use of the ophthalmoscope in the hands of one who can positively diagnose the refractive condition of the eye, independent of any statement of the patient.

Hyperopia in the young is the most frequent cause of obscure weak vision. Having demonstrated its existence the cause of the troublesome vision has probably been found, or having demonstrated its now existence, the only two remaining possibilities are some error of accommodation or some defective ocular muscle. Any young person not having hyperopia who requires convex glasses to read with, has a disease of his accommodation which probably requires rest and tonics rather than mechanical treatment with convex lenses. Having excluded all of the above conditions, we still have a mechanical ocular defect remaining which is a frequent cause of weak vision, namely, a defective ocular muscle which prevents the proper direction of both eyes at the same object without causing fatigue. The exclusion of muscular defects will be considered under ocular muscles. The process of exclusion where distant vision is perfect having been considered, we will now consider it under a second condition.

When distant vision is defective:

Here every one of the possible conditions which cause defective vision may exist, and we are obliged to systematically eliminate one cause after another till we arrive at one which cannot be excluded. One glance into the eye with the ophthalmoscope demonstrates the existence or non-existence of visual obscurities. When they are absent a clean, bright retinal reflex is seen; when they are present the retinal reflex is absent, broken or interrupted at some point. The trial with convex lenses will demonstrate the existence or non-existence of hyperopia. Hyperopia not existing the effect of concave

lenses on distant vision will demonstrate the existence of non-existence of myopia.

Hyperopia and myopia not existing, one glance at the astigmatic disk will demonstrate the existence of astigmatism. If absent these lines will all appear equally dark; if present, some lines will appear decidedly darker than others. A trial with convex and concave cylindrical lenses will demonstrate the nature of the astigmatism positively, although the mere fact that lines vertical or nearly so makes the existence of myopic astigmatism strongly probable. When the darker lines are horizontal or nearly so the existence of hyperopic astigmatism is probable.

Obscurities of vision and all errors of refraction having been demonstrated not to exist, amaurosis or amblyopia are the probable causes of the defective distant vision, which subjects are not considered under correctible mechanical ocular defects, they belong to the field of medicine.

From what the patient sees, as well as that which the observer sees, some conclusions may be drawn confirming the conclusion that the trouble is due to disease in the optic *nerve, retina, brain* or choroid.

Thus smoke is seen when there is no smoke; this indicates choroiditis. All shades of red and green not being recognized is one of the most common symptoms of atrophy of the optic nerve. When with either or with both eyes only one-half of every object is seen, disease in the optic tract is indicated; if with one eye there are certain positions in which objects are not seen, retinal detachment is probably present. If objects appear large, small or irregular, chronic sub-acute retinitis probably exists.

In the above trial with simple lenses it may be demonstrated that a given error of refraction is no part of the cause of imperfect vision, or it may be demonstrated that it is the entire cause of imperfect distant vision, in which case the lens correcting the defect will be a simple one. It may be demonstrated that hyperopia or myopia accounts partly for the bad vision, while astigmatism accounts for that portion of the defective vision which the correction of the hyperopia or myopia fails to restore. In this case the correcting glasses must be compound lenses.

We have now a general idea of the nature of the work before us. Each subject which we have referred to in a general way will be considered under a special chapter in detail.

A class in optics will probably form during the last week in March. The time will be communicated by mail to those applying for a place in the class.



[FROM OUR SPECIAL CORRESPONDENT.]

A NEWSY MONTH.—THE HALL MARK AND THE DUTY ON SILVER PLATE.—ROBBERIES IN THE TRADE.—WINDOW-DRESSING IN OLD ENGLAND.

LONDON, February 15, 1889.

The same difficulty always presents itself to my mind when I commence my monthly communication to you, I have so much that I could say and so little space in which to say it. It is said of a celebrated divine that being asked how long it would take him to prepare a sermon, he replied that it depended entirely upon the character of the sermon required. If a sermon to occupy about an hour and a half in delivery, and in which he might be permitted to speak freely and fully upon the subject in the various lights in which that subject would present itself to his mind, he said he could prepare it in about half an hour. But if it was desired to have a closely

reasoned exposition of any one truth or doctrine practically dealt with in a clear, intelligible discourse of about half an hour's duration, he would require about three weeks to think it out. In other words, the longer the time at his disposal the less difficulty he had to occupy it. This remark is called for by the fact that there are several matters pertinent to the jewelry trade so prominent just at present, that to say what could easily be said on any one of them, would fill the space to which you limit me.

The presentation of jewelry to Mrs. Joseph Chamberlain, by the people of Birmingham, has been the great subject of discussion by the trade in various parts of the country.

The exhibition of the presents at the Birmingham Art Gallery, where I saw them last, will no doubt do much to render more popular that very neat and artistic style of ornament which is always so preferable to the mere display of value in an unsightly lump.

I cannot spare time, or rather you cannot spare me space, to do more than mention the first dinner of the Jewelers and Silversmiths' Association which took place on the 28th ult., when Mr. Joseph Chamberlain, M. P., formerly President of the Board of Trade, was present and made a remarkable, and from a manufacturer's point of view, a very encouraging speech. It is sure to have found its way into some of your papers, and I advise those of your readers who may see it, to read it—it is worth the trouble. The manufacturers are much divided in opinion as to two great questions of the hour. The compulsory Hall-marking of goods and the talked of abolition of the duty on plate. Whether the latter will be abolished or not is doubtful. There does not appear to be any argument against their removal, provided, of course, that equitable allowance is made for the large stocks of duty paid silver that some firms hold.

There has been an unusual number of robberies of jewelry—both from private owners and from the trade. The means adopted, however, are of the old type: A porter accompanies a factor (jobber) in his rounds and is left outside a shop with sundry packages while the factor enters. During the absence of his employer the porter leaves his post for only a minute, and on his return one of the bags or boxes containing property worth hundreds of pounds is missing. The porter knows no more. What can be done? This: Factors both in your country and ours who carry stocks of value should always be accompanied by a responsible clerk or assistant, from whose sight the package should not be removed during the absence of the principal. This is so simple a precaution that I fear it will not be adopted.

I have, since I last wrote to you, seen more of our jewelers' shops in Manchester, Liverpool and Birmingham, than of our manufacturers' stores in London. When I say I have seen more of jewelers' shops I should, perhaps, say, more of their shop windows. I have paid some considerable attention to shop windows lately, and from some of them I fancy I have learnt something of the improved taste of their owners. I notice that a very great improvement has been made in window displays during the last few years. Ten or twelve years ago it would have been difficult to imagine the development that has taken place in the art of window dressing. It certainly is an art, and one that will pay for cultivation.

The opinion I have come to as to the result of my recent inspections, is that one-half of the present more pleasing effects produced by our jewelers' windows is due to the great reduction in the quantity of articles shown.

We have only to compare some of the better shops now with some of the others, to see that the main thing to avoid is overcrowding.

The best taste in the arrangement of the windows of some of our best jewelers is making itself felt by its simplicity. The most effective window displays are those in which goods are shown in very moderate quantities. The majority of windows, however, do not exhibit this taste.

I have some notes on this subject made during the last fortnight, and, with your permission I will refer to this subject at a future time.

Yours faithfully,

VIGILANT,

Obituary.

ELIAS MORRIS.

Elias Morris, vice-president of Giles, Bro. & Co., and one of the best known members of the jewelry trade in Chicago, died of diabetes on Sunday, February 10th, aged 50 years. Mr. Morris was a native of North Wales. He was born in 1838 and came to this country in 1852. He was for many years connected with Mayo & Co., and in 1864 joined the firm of Giles, Bro. & Co. He had entire charge of the retail department and also did the principal part of the buying. There was probably no man in the jewelry trade in Chicago who was so widely known and had so many friends as the deceased. A meeting of the leading jewelers of Chicago, was held at the rooms of the Chicago Jewelers' Association, on Tuesday, February 12th, to take action in reference to his death. Resolutions expressing the high esteem in which he was held were passed and a motion made to attend the funeral in a body. The burial rites were in charge of the Masonic fraternity of which he was a prominent member.

SAMUEL H. COWELL.

The jewelry trade was shocked on Saturday, February 16th, to hear of the death of Samuel H. Cowell, of the Cowell & Hubbard Jewelry Company, Cleveland O. Mr. Cowell was born March 12th, 1849, in Sherbourne, Dorsetshire, England. He was brought to this country in infancy, his parents settling in Cleveland, where almost his entire life was spent. He commenced his business career as book-keeper for a wholesale shoe house; subsequently he went into the real estate business, in which he continued for a year or two, forming his connection with the jewelry business in the fall of '75, with his brother who was an engraver by trade. The two opened a store on Bank street under the firm name, Cowell Brothers. Prosperity attended them, and after four years A. J. Hubbard was admitted into partnership, the style becoming Cowell & Hubbard. In February, 1887, the Cowell & Hubbard Jewelry Co. was formed with Mr. Cowell as president and treasurer, and the incorporation was soon followed by their removal into the finest jewelry and art store in the city of Cleveland, the company making a speciality of fine bric-à-brac, pottery and other fancy goods, as well as handling the most artistic jewelry. Mr. Cowell's health began to fail about two years ago and his disease soon proved to be a dangerous disorder of the liver from which he vainly sought relief at medicinal springs, both here and abroad. As a last resort he recently spent eight months in Carlsbad without experiencing any permanent relief however. He was a kind and courteous Christian gentleman, whose loss will be deeply felt, not only in trade circles but in the religious and social life of the city, one of whose representative young business men he was.

WILLIAM J. MILLER.

William J. Miller, perhaps the oldest business man of Maiden Lane, died at his home in Brooklyn, February 15th, in the 80th year of his age. He was born at New London, Conn., August 20th, 1809, and came to New York at the age of nine. He attended school two years and then entered the employ of a shipping house, after which he was bound out as an apprentice to Francis Tomes, an importer of fancy goods in Maiden Lane. In 1832 he went to Europe for the house, embarking on a sailing vessel, which took 18 days to accomplish the voyage. On his arrival home New York was almost depopulated by the cholera scourge, and it was with much difficulty that he found where his family were located, all who could afford it having fled the city. In 1833 he was admitted a partner, the firm becoming Tomes & Miller. For five years the partnership continued, during which the firm encountered and weathered the great panic of

1837, although the senior partner was absent in Europe when the crash came. Mr. Miller's coolness and good judgment saved the day, however, Tomes & Miller being among the few firms that did not go under. After the dissolution Mr. Miller continued in the fancy goods and silver plated ware business successfully until 1873, and even after retirement from active business he kept an office in Maiden Lane up to within a few months of his death. He was, therefore, engaged in business on Maiden Lane, from 1826 to 1888, a period of 62 years, with the exception of one year in John street. The general stability of his character is further illustrated by the fact that he lived for over 50 years in the house in which he died. His sons, of whom he had five, were all brought up on Maiden Lane. The eldest are twins, Frank G. and Fred J., the former after a connection of many years with the Waterbury Watch Company having recently taken the position of general selling agent of the New York Standard Watch Company, and the latter having been engaged for many years in the sale of fire apparatus at No. 72 Maiden Lane. Another son, S. M. Miller, was up to the time of his death, 3 years ago, a member of the firm of Phelps & Miller, San Francisco. Charles A., the fourth son, is one of the managers of the Singer Manufacturing Co., and the youngest, George T., was several years with Schuyler, Hartley & Graham, 19 Maiden Lane, and is now in the lithographing business. The only daughter is the widow of the late S. F. Phelps, for 20 years employed in the Mercantile bank. As an instance of the rise of real estate values in Maiden Lane, Mr. Miller occupied the ground floor at No. 15 Maiden Lane, for 3 years, at an annual rental of \$1,500, and the landlord was so anxious to secure him as a tenant that he fitted up the store with show cases and counters at his own expense. Orestes Cleveland, now Mayor of Jersey City, was in partnership with Mr. Miller for four years.

A few months before his death one would not have thought for his personal carriage that he was over 65 years of age.

DWIGHT H. BUELL.

His many friends in the trade were shocked to see among the victims of the terrible hotel disaster at Hartford on the 18th, the name of Dwight H. Buell, the popular jeweler of that city. Mr. Buell had been a boarder at the ill-fated hotel for ten years, and his body was among the first taken from the ruins, he having escaped the more terrible fate of those who were incinerated among the debris.

Dwight H. Buell was born in Litchfield, Conn., in November, 1833. He went to Hartford when a lad, and attended school there, afterwards entering the jewelry establishment of Thomas Steele, where he learned the business, and later became a partner, the firm being for several years, T. Steele & Co. About 25 years ago Mr. Buell and Mr. Chas. J. Wood, who had been in the employ of T. Steele & Co., commenced business in the well-known store, near the corner of Main and Asylum streets, under the name of D. H. Buell & Co. A few years later Mr. Buell purchased the interest of Mr. Wood, and since that time the business has been successfully conducted by him alone. He made hosts of friends among his fellow-citizens, who felt that his word could always be depended upon. Mr. Buell was unmarried, and leaves a sister, Mrs. J. G. Rathbun, of Hartford. He was one of the original members of the Hartford City Guard, having served five years, and was a member of the Veteran Association of that company. He was a member of the Hartford Club, and of the N. Y. Jewelers' Association, at whose annual banquets he was a welcome and honored guest. His kindly disposition and never-failing geniality gained him many friends in different parts of the country. Some time ago he made the request that when he died he should be buried beside his mother in the cemetery at Watertown, Conn., and, after the funeral services Wednesday morning, Feb. 20th, from the residence of his brother-in-law, Mr. J. G. Rathbun, the body was taken by train to Watertown, where services were also held on its arrival.

Lathes and Lathe Work.

BY THE MODEL WATCHMAKER.



BEFORE WE describe the method of making cutters for stem winding wheels we will finish our winding arbor. The cutter will leave some burr on the ratchet teeth; this is to be removed by a fine file, and afterwards smoothed with a piece of pegwood and oilstone dust and oil. The part to form the winding square is now turned to the proper size and cut to the right length. Squaring the winding post can be done now or after the arbor is hardened. Undoubtedly the best way is after

hardening, which process is effected in this way: scrape some Castile soap into dust and with a little water from it into a thick paste, and with a piece of tissue paper wrap the arbor up with the soap paste into a nice little package, then heat red hot on a bit of charcoal with a blowpipe and throw into water, when it will be found white, and file hard with no appreciable scale on it. Place it in an old tea spoon bowl and pinch off a small piece of beeswax and lay on the arbor, and heat the spoon until the wax flows over the arbor and blazes. Allow the spoon to cool, and throw the arbor into benzine to remove the small amount of wax adhering. Next place the round part of the arbor which you intend to square up in a split chuck, and with a piece of flattened pegwood smooth up the parts with oilstone dust and oil, and finally polish with diamantine and alcohol. After the lower part is polished the arbor can be reversed in the split chuck grasping by the screw; the winding square can be filed into shape. Grasping the screw will not mar the thread enough to injure it materially; if it should do so, take a small piece of stencil brass, such as stencil plate makers use for name plates, and after annealing it wrap it once around the screw, when the brass will effectually protect the thread. We will now take up the making of cutters for stem wind wheels. Prepare some more soft steel discs like the one used for cutting ratchets, and fit them to the same chuck as we used for that purpose. In making cutters for stem winding wheels it should be borne in mind that the best teeth for this purpose are not shaped like the ordinary spur gear teeth in the brass wheels of a watch train, but should be shaped as shown in fig. 1. The teeth in most of our later makes of American watches are of the proper form. One of the steel discs is placed on the chuck and the edge turned to correspond to the shape of the tooth. This will be understood by inspection of fig. 1, where the form of the edge of the cutter is shown at the shaded lines. It will be seen the cutter only corresponds to the curve of the tooth until the center of the top of the tooth is reached, then the curve rounds out to *aa*, fig. 1. The cutters are cut with a graver as described for the angular cutter in December number of this journal, and repeated at fig. 2 where the arrow *b* and dotted line show the direction in which the graver is pushed. The teeth at the edge of the cutter are made before the the cutter is turned into the shape of the teeth. To explain: at fig. 3 is shown the edge of a cutter blank or disc. In the edge of this is cut heavy incisions with a graver as shown at *e*. It will be seen the graver commences to cut near the edge of the disc and is pushed across in the direction of the arrow *c*. When the disc is turned to correspond to the form of the teeth, the edge of the cutter will correspond nearly to the dotted lines. A little practice will soon put a person up to the proper methods. Such cutters make as fine steel wheels as one could ask. They should in all cases be kept well oiled when in use. It is very easy to make our machine cut bevel gear, but we will be satisfied for the present to arrange for cutting plain spur gear. For divisions we can use our old barrel for all multiples of 60, like 12, 15, 20 or 30. To hold our wheels when being cut, we

turn an arbor (*E*, fig. 4,) to go into the place of the pin we used for our winding arbor, only in the present instance we can use the arbor we now make for almost all flat stem wind wheels we will be called upon to make. The end at *h* is turned as shown to about .05 of an inch in diameter, and the wheel to be cut is placed on the arbor at the dotted line *g*. The lines at *f* indicate where the old watch barrel is placed. The soft steel wheel placed at *g* can be held firmly by blowing a little soft solder between it and the shoulder of *E*. In preparing steel for such wheels and also for cutters, a charcoal annealing box should be used. Such a box has repeatedly been described in this journal, but for the benefit of such new readers as are constantly springing up, I would briefly say one can be made of a piece of wrought iron pipe $1\frac{1}{2}$ inches in diameter and 8 inches long. In one end is welded a plug of wrought iron and into the other end a loose plug (also of wrought iron) is fitted. This piece of tube is filled with fine charcoal and such pieces of steel as we wish to soften. The loose plug is put into the open end and the joint smeared with a thick paste of whiting and water. The tube is slowly heated in a stove or furnace to red heat, and then burned in hot ashes and allowed to cool very slowly. Steel annealed in this way can be readily cut with a graver. For dividing such stem wind wheels, as watchmakers have no old wheels to use for division wheels, new ones can be cheaply obtained of such men as Geo. B. Grant, 66 Beverly street, Boston, Mass. You can get of him small wheels of 48 pitch of almost any number of teeth up to 48 for from 15 to 30 cents

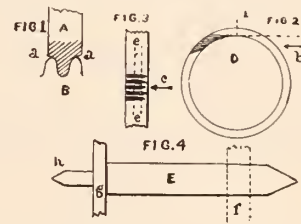

a piece, all ready to slip on the arbor *E*. It is seldom we need wheels for stem winding works with over 44 teeth. The kind of gear wheels we see on some Swiss watches and known as *dent-de-loup* or wolf teeth gear (they are also called epicycloidal teeth), are quite as easily made by shaping the cutter to suit and then cutting them with the graver. It may not be amiss to say the graver commences to cut opposite the line *i*, fig. 2. After the teeth are cut and the wheel removed from the arbor it should be well brushed with chalk and alcohol, to which a little ammonia is added to remove any trace of soldering fluid where the wheel was temporarily soldered to the arbor *E*. The burr made by the cutter is removed by rubbing on a fine flat file, and the teeth brushed out with a scratchbrush of fine steel wire running in the lathe. Such scratchbrushes are part of a dentist's outfit and are to be obtained at the dental depots. They are about 2 inches in diameter, and the wire half an inch long and not more than four or five one-thousandths of an inch in diameter. They are used with emery mixed with tallow. A few minutes with such a scratchbrush and the teeth are smooth and nice; quite equal to any from the factories. Grind the flat sides with oilstone dust and oil on a roughened glass slab and they are ready for hardening.

Canine Lace Smugglers.

FOR A considerable time lace and other articles were smuggled between Belgium and France by means of dogs. They were sent forth in the twilight, so that they habitually made their journey during the night. By methods strenuously carried out a complete training was soon effected, through which the dog, when deemed fit to enter upon his smuggling career, was able, by his continual excursions to and fro beyond the frontiers with the valuable loads intrusted to him, to bring in an excellent income to the master engaged in this illegal trade.

It was not likely, however, that a system like this could long be

unnoticed, when men who had hitherto been poor and needy and who were known to have been hardly able to gain a subsistence, became wealthy in an amazingly short space of time. This mode of smuggling was discovered; but still it kept its ground owing to the cleverness of the experts engaged in it. At Mabuse there was a dog which had acquired so great a renown that he was dubbed *le diable* by the authorities. A price was set upon him. He was white, so all white dogs were carefully watched; but this dog was white no longer; the color of his coat was frequently changed, and his master dyed him black, brown or light tan by turns. It was the sudden accession of riches to the owner of this dog and his indiscreet display of them, by building a large and handsome house, that had riveted the attention of the revenue authorities upon this man's movements in the first instance; but the dog was very skilful and long evaded the emissaries of justice. Snares and ambuscades were laid for him. Many tales were told of the artful manner in which he avoided them. At one time he mingled with a flock of sheep right under the eyes of the commissary of police; at another time he trotted the whole distance under the very carriage which was conveying the officer of excise who was on the lookout for him. But the poor fellow was run down at last. Being sore pressed, he endeavored to cross the Scheldt by swimming, and might have succeeded even then in effecting his escape had he not received previously a slight gunshot wound. As it was, he met his fate and was drowned. Within the false skin of *le diable* was found packed rich lace to the value of 50,000 francs.

Pearls at the Berlin International Exhibition (1880).

PART I.—SEA PEARLS.



IT WAS A happy innovation on the part of the commission of the International Exhibition at Berlin, 1880, to allow a separate department for that beautiful product of ocean and river—the pearl. No other prize which man seeks to win from the depths of the sea can be compared in value and loveliness with this, and the high estimation in which it has always been held as an object of luxury and fancy justifies the exertions put forth and the great dangers endured in its quest. As far back as history goes and thence down through the advancing civilizations, the pearl has been regarded as the gem most worthy of a place in the royal crown and the diadem of beauty, and poets and romancers have loved to dwell on the mysteries of its origin. One of the most charming of the ancient legends is that which traces its origin to the tear of a goddess fallen into the sea or a drop of dew lost by Aurora. Modern scientists, however, have a more rational, if less romantic, explanation for the little pearly body that is found in the inner mantle of an insignificant testaceous animal, rarely separate therefrom and generally grown fast to the shells, which are given to the animal for protection against enemies, external and internal. Very often, they say, in cases where a parasite has tried to penetrate the shell of the oyster from the outside, there is a thick swelling of the nacre on the inside, whereas when the foreign body, be it an animal or a little piece of stone, penetrates between the shells, the oyster tries to make the intruder harmless by secreting around it a pearly mass, thus giving rise to those more valuable pearls that are found lying free between the shells. But in both cases the abnormal secretion serves as a protection against the enemy. The foregoing brief observations will suffice to explain how the forms, sizes and colors of the pearl show such a remarkable variety, and how an exhibition of pearls, properly classified, must afford both instruction and delight to the spectators.

Pearls differ in color, white, blue, yellowish, brown and even deep black, according to the place where they are found. Ocean pearls

are generally distinguished by their superior splendor, while river pearls are leaden colored, as a rule, and have little luster. In like manner the size varies from that of the smallest grain of sand to that of a large cherry, and it is even reported that in the 16th century a Spanish nobleman took home with him to the court of Philip II. a pearl found in the Gulf of Panama of the size of a dove's egg. The greatest value is attached to the round pearls, though the pear-shaped ones are highly esteemed and are used as drops or to embellish ornaments. If a single round pearl of a good color and fine luster is so great a rarity, it is easily understood how fabulous sums are willingly paid for a necklace of such pearls. The places where the ocean pearls, now almost constantly called Oriental pearls, have been found during the last few decades are the Gulf of Panama, the lower districts of California, the coasts of some of the West India islands, and different localities in the Indian Ocean and the Red Sea. The pearl-bearing oysters live together in large numbers, from 25 to 40 meters below the surface of the sea. The fishing is very arduous work and is done by divers, generally natives of the district and from youth up inured to its dangers and fatigues. The divers go down to the bottom, and breaking off from the oyster bank as many shells as they can carry seek the surface again with all speed. The shells are immediately opened in order to secure their valuable contents, and those that are found to be without pearls—by far the greater number, are simply wasted, for if left undisturbed they might become pearl-bearers. This waste is greatly to be regretted, and the rapid destruction of the pearl oysters in consequence of it has necessitated the adoption of more careful methods. On some of the coasts fishing has been prohibited for several years by the government, in order to give the oysters time to propagate and accomplish the restoration of the beds.

River pearls are less valuable than the Oriental or ocean pearls, because they are not always so beautiful. They will be especially treated of in another chapter. The art of producing imitation pearls has now been brought to a high degree of perfection. This imitation consists principally of hollow glass or wax balls, lined with a material shining like nacre, which is obtained from the scales of certain fresh water fishes. Since the 16th century these artificial pearls have been manufactured in Italy and France quite extensively, and of late, such is the perfection attained, that the eye of a connoisseur is needed to distinguish the imitation from the natural product.

From this brief general review it will be seen that the exhibitors had to cover a wide field in order to give a good idea of the different species of pearls, classified according to form, color and locality, together with illustrations of different stages of their growth. As pearls are used almost exclusively for ornament it is natural that those should be entrusted with the arrangement of the exhibit whose business was the preparation and sale of pearls for this purpose. The Berlin jewelers accordingly took the matter in hand. Taking the trouble to bring from foreign countries everything of importance which they did not already have in stock, thus making the exhibit as perfect and homogeneous as possible from an instructive point of view, and to show how numerous are the forms in which the pearl is used in ornamental and art objects, they were careful to select the best examples of jewelry from their own stocks. It was not the intention to have a great number of exhibitors. On the contrary, the object was to present as perfect a collection as possible of the special features of the four jewelers charged with the arrangements for the exposition, S. Friedeberg & Sons, Friedlander Bros., Haller & Rathenau and Sy & Wagner, all four court jewelers. These merchants entered upon their tasks with a complete understanding of it, and made it a special object to show how highly prized the pearl ornament is in our time. And what an extraordinary collection these four firms made! In a showcase of large dimensions they gathered the best the treasure vaults could produce. Every object on exhibition contained pearls, from the noble diadem to the ring—pearls of all shades and colors.

The principal piece of the collection was a great pearl shell with

two fast grown pearls, each of which weighed between eighty and one hundred karats. This rare shell was arranged like a nest containing two eggs, richly set in brilliants, the similitude being completed by two brilliant birds flying towards it, each bearing in its mouth a pearl as it were food to their young. A very pleasing and natural little study in gems.

Of pearl necklaces of all sizes and of fancy ornaments there was no lack, and the varied tints were used to produce striking contrasts, large black or rose-colored pearls showing to fine advantage between white and yellowish ones. One attempt was also made to illustrate the manner in which pearls were used in the reproduction of all Renaissance patterns. Sy & Wagner and Friedlander Bros. made this a special exhibit from drawings by architect Heyden. Prominent among the exhibits of the first named firm was a nautilus—a mussel carried by a siren and beautifully etched with figures. The foot was richly set in coral and pearls. This magnificent house ornament, which has since passed into the possession of his majesty the Emperor, made a great impression, and has been reproduced extensively in less precious materials. The house of Lowenstein Bros., imperial jewelers, of Paris, London and Frankfort was distinguished by a collection somewhat smaller but no less inferior in quality. One of the most noteworthy features of their exhibit were three rare strings of large pearls, one of white Panama valued at 100,000 marks, one of yellowish Oriental valued at 80,000 marks, and a string of wonderful black pearls valued at 120,000 marks. Besides these there were ornamental pieces set with great pearl buttons and pearl drops, among them being a brooch with three rose-colored pearls of almost fabulous value. Scientists have not yet agreed whether such large rose-colored pearls are contained in pearl oysters or originate from some other testaceous animal, but Professor Moebius, a prominent savant in this line, has promised to make an examination of one of them and endeavor to give more reliable information about it. In addition to their main exhibit the Messrs. Lowenstein showed some very handsome small figures as examples of the manner in which baroque pearls may be applied. These were made after the models of Dinglinger, and were copied from those in the Dresden Green Vaults. Not the least interesting part of their exhibit was a collection of more than one hundred oysters from all seas containing rudiments of pearls.

Louis A. Goldsmith, the Parisian jeweler, had on view a large collection of rich pearl necklaces and pearls of all colors, among which was one of a very rare yellowish color and perfect globular form, weighing about one hundred and fifty karats.

Julius Engelhard, of Hanau, had gathered for the occasion from all seas a collection of round and baroque pearls, which in respect to form was very instructive, and afforded a good idea of the use of baroque pearls for decorative purposes. Two strings of large and rare pearls which it had taken Mr. Engelhard years to gather, proved that it is possible with perseverance and good judgment to find quite a large number of pearls well matched in shape and shade. Mr. Engelhard had also prevailed upon Mr. Spencer, of Bradford, to exhibit a number of pearl oysters in which the natural inside growths of the nacreous layer were used for figurative representation with the assistance of the painters art. Oysters were exhibited showing animals or human heads apparently the handiwork of nature. L. Schlessinger had arranged a separate exhibition in connection with the firm of H. Meyer & Co. The most noteworthy thing was a center piece of oysters set in silver after the design of architect Hayden, the richly ornamented bowl of which was carried by Tritons and water nixies. These firms also exhibited a fine series of pearl ornaments and some cork pieces showing the different uses to which baroque pearls are put in ornamentation. In order to give greater brilliancy and completeness to the display the Saxon government loaned some of the rare art objects from the famous Dresden Green Vaults. There were jugs, vases and figures from the most artistic period of the Renaissance, ornamented lavishly with pearls. This portion of the exposition was one of the chief points of attrac-

tion, and was viewed with interest by that large number who are unable to see these treasures at the usual place of keeping. The principal exhibitors of artificial pearls were the well-known firm of Castellani, of Rome, which presented some strings of so-called Roman pearls, and the firm of Constant Vailes, of Paris, who, during the past few years have attempted to make these imitation pearls heavier and more durable, so that not only the cover, which was formerly quite fragile, but the whole pearl has gained in strength. Pearls are imitated in all colors and in all regular and irregular forms, and it must be conceded that even the practiced eye of the jeweler could scarcely conceive of a more perfect resemblance. This firm claims a secret process for the manufacture of the inmost nucleus, and the fish scales for the outer coating are dissolved in a peculiar manner known only to them.

The firm of A. Kugelmann, of Hamburg, exhibited a fine collection of nacre, so much admired in all branches of art industry, in its various forms from large shells down to the thinnest cut leaflets. In the same room with the pearl exhibitors another German house, Martin Meyer, of Mayence, undertook to compete with the largest exhibitors of Italy in the coral line. This house has been engaged in the coral trade for the past twenty years, their custom being to have the material specially prepared in Italy and then separate it with respect to color and style of cut, according to the country to which it is to be exported. Their display was very complete, embracing all the kinds and forms of coral from the reef to the finest set ornament. It was very interesting to note the tastes of the different nations as exemplified in this exhibit. The half wild tribes of South Africa and the Indian Archipelago have very different standards of beauty from those which prevail among the civilized nations of the world. While in distant countries the dark red color seems to be chiefly prized, among Europeans it is the rose color that is most valued.

Having mentioned briefly all the points of interest in the pearl collection, we will add that in the same room with it were exhibited all the splendid gifts of honor which had been given to the International Exhibition by jewelers and corporations. The reader will need to give his imagination full scope to picture to himself all the splendor of this room devoted to the display of such marvels of nature's and man's skill joined in harmonious creation.

Outside of the general exhibition of the jewelers there were some very interesting sea pearls. First, the Japanese department contained a box of pearls from *Avicula glabra* (Akoya gai), from Omura (Nagasaki-ken), and also an oval pearl in weight (0.37 grains), one octangular pearl weighing 2 Rin (0.07 grains), 57 pearls of medium size (1.6 momus a 3.7 grams), a number of small ones (8.5 momms), and some smaller still (1.3 momms). These were all arranged around the shell of the producing oyster in neat meandering figures and covered with glass. Luster and color were both equally good. There are many other pearl-yielding molluscs living in the Japanese waters. Those which were exhibited under No. 145 of the special catalogue were: *Pecten yessoensis* (Hotategai), *Arca subernata* (Aka-gai), *Cytherea ptechialis* (Hamaguri), and *Tapes semi decussata* (Asari), as well as *Haliotis gigantea* (Awabi), a peculiar kind of snail. The mention of this latter variety recalls the fact that the exhibits of the jewelers contained large rose-colored pearls of a peculiar porcelain-like luster, quite different from that of the other pearls, a peculiarity which gave rise to the suspicion that these pearls were in reality the product of large snails, *e. g.*, the *strombus gigas*. Whether the pearls from the above named Japanese oysters could be used to advantage as ornaments it is impossible to say, as no examples were exhibited, but from the quantity of the shells it may be inferred that the pearls resemble closely those found in our oysters (*ostrea edulis*) and mussels (*mytilus edulis*), a very good series of which was exhibited by the Ministerial Commission for the scientific investigation of the German seas, and the Zoological Museum at Kiel (Dr. Neyer, Prof. Moebius, Dr. Karstan and Dr. Hensen), under Nos. 115 and 116 of the general catalogue. These pearls are as interesting zoologically as they are

valueless to the jeweler. However, the exhibit of the firm of A. Castellani, in Rome (Piazza di Tountana di Frero), proved quite conclusively that pearls from oysters having a very thin layer of nacre may be used for ornamental purposes. This firm (No. 64 of the Italian special catalogue) showed a collection of pearls fished on the coast of Sardinia, a miscellaneous lot of round loaf-shaped or drop-shaped formations showing two colors, now a dim grayish brown and then a glossy one like that of cornelia; a few of the smaller ones had a peculiar iron-like nacre or gloss. Because they were placed near the imitation pearls and showed such abnormal forms, many who saw them obtained the impression that they were artificial. On closer examination, however, the surface was seen to be covered with polygonal maeandric designs, and the structure of the interior also favored an organic origin. They appear to be genuine pearls formed from the prism substance of a horn colored transparent oyster. It is probable, according to the statement of the Italian commissioners, that the mother animal is the large pin mussel (*pinna nobilis*), which is found in great numbers on the Sardinian coast. The color of the pearls of nacre substance gives further strength to this view. It is interesting to note how the prisms, which in the round pearls were arranged in the direction of the radii of the balls, in the case of the drop-shaped ones re-arranged themselves in the tapering end.

(To be continued.)



[FROM OUR SPECIAL CORRESPONDENT.]

RIVAL FACTIONS IN THE CRAFT.—"HISTORY OF THE CROWN JEWELS," BY BAPST.—PREPARING FOR THE EXHIBITION.—A GLANCE AT THE SHOW WINDOWS.

PARIS, January 30, 1889.

Our manufacturing jewelers are divided into two classes, the bijoutiers and the joailliers, who both seem anxious for the moment to be widely separated from each other. The bijoutiers are bent upon making jewels with gold, silver and platina alone, and declare that, in working these three metals, they can obtain all desired effects. They add, besides, that it requires a great deal more talent to beat, twist and change a metal into something elegant than to group stones already cut and prepared as is generally done. On the other side, joailliers think that gems have in them all the beauty and attractiveness which ought to be found in articles of adornment.

We confess that we are unable to understand why a jeweler should confine himself to a specialty when he is not absolutely obliged to. According to our humble opinion he ought to try to attract custom by all the means in his power, and, therefore, make use of all precious metals and stones, and arrange them in all the endless variety of styles that exist or are worthy to exist. A jeweler who wilfully deprives himself of any of the materials which he could successfully employ, seems to us Paganini playing a whole violin piece on one single string. He may show himself very clever, but art has nothing to gain by it.

Yet, we must acknowledge that some interesting results have been obtained by both bijoutiers and joailliers. We have stopped many a time before various shops in the Rue Richelieu and the Rue de la Paix where the display of jewelry is oftenest changed. The show window exhibits one day nothing but gold articles, the next oxidized silver; then comes platina married with gold; next we see stones sparkling on metal, and at last appear gems, in all their glory, with the mounting almost invisible. Every one of these exhibitions is

worthy of notice, and calculated to give a thorough idea of what can be done in each one of these different lines. The monotonous sameness which metal alone offers to the eye is greatly relieved by repercé work or coloring. For instance, a bracelet whose band consists of a Louis XVI. ornament on a pierced background of pale gold varied with green, has for a clasp a beautiful oval medallion circled with green gold pearls, which is bordered by a narrow rim of red gold, while the center on which the initials are to be engraved is of a dead yellow. This makes, no doubt, a very dainty piece, but the effect of it would be entirely lost if jewels formed of a grouping of gems were placed near it. The jewelers have, as a rule, the good taste to avoid such contrasts.

We cannot longer resist saying a few words about the *Histoire des Joyaux de la Couronne*, by G. Bapst. To give a full account of that rather bulky book would carry us too far. It is full of historical details, evidently founded on most reliable information. The author could easily, out of his family papers alone, have gathered all the data necessary to write an interesting work on those jewels. It is matter of regret that the illustrations are so few (50 altogether) in proportion to the importance of the book, which contains 700 pages. We should have liked to see M. Bapst, who is a thorough jeweler and true artist as well, give us illustrations of all the jewels he describes so carefully, and sketches indicating the various changes and alterations in the royal fashions. It was certainly not too much to expect from him.

We give here a copy of Queen Marie Leczinska's necklace as worn by her on the occasion of Louise Elizabeth de France's marriage with the Infant of Spain in 1739. This necklace is of the shape called carcan (in fashion at the time of Louis XV.) consisting of diamonds applied on velvet, and was called by that name because it was worn rather tight. The present illustration, which is an exact copy of that reproduced by M. Bapst in his book, from a drawing belonging to the house of Bapst & Falize, shows us Marie Leczinska's necklace having the Regent in the center and the Sancy as a pendant. Now,



the former of these two celebrated diamonds is really bigger than the latter, and yet it seems here just the reverse. As we cannot suppose that a mistake of this kind, so glaring a misrepresentation, could have occurred in a work so carefully written and coming from so high an authority, we must imagine that, in order to set off the Sancy for the occasion, a great portion of the Regent has been cleverly hidden, partly underneath the velvet and partly by the surrounding stones and ornaments.

January is not a favorable month for the invention of novelties of any kind. Manufacturers seem to require a little mental rest after the over-exertion of December. The coming orders are quietly executed and generally sent in the proper time without the slightest hurry, and stock is being prepared for the expected wedding presents.

Yet, all cannot think of taking it so easy. For instance, those who are preparing for the Exhibition, which is fast approaching, have, generally speaking, no time to waste. They are naturally anxious to make their work as perfect as can be, and have very often to do it over and over again. It is almost impossible to ascertain yet what the principal features of the exhibitors in the jewelry and silver plate

lines will be. Are we to expect a large number of true novelties, or will it be either a careful or a free imitation of ancient styles which the glass cases in the Champ-de-Mars will show us? At all events we are quite prepared to see many interesting pieces, as we feel sure that all those who take a part in the forthcoming competition (to whatever school they may belong) are determined to show this time the very best they can do.

Silver mounted crystals of all descriptions are seen now at the jewelers' shops. Some of these articles are really beautiful. A liquor set of that kind looks very neat and light. The glasses are supported by an elegant twisting of boughs intermingled with leaves, while the decanters are partly covered with vine leaves, stems and grapes from the base upwards, the whole shooting about promiscuously, and seeming to obey no law but that of nature. On the top of the handle (in the same style) a Bacchus' head peeps out of a knot of foliage. The spout and its lid are of a very graceful curve. The mounting of those exhibited in the best places is partly in *repousse* work and partly in chasing. But we have seen some in second-rate shops in which all the designs on the metal are evidently done by stamping.

We noticed the other day in a show window where choice pieces are always to be seen a rather original candlestick. It consists of a large shell beautifully formed. A mermaid, who seems to have sprung into it, holds her body upright, and a small shell resting on the top of her head serves as a receptacle, while her tail, thrown back with a slight curve, is meant to be used as a handle.

The pink, General Boulanger's favorite flower, is widely partaking of its patron's recent success. It is exhibited in all kinds of styles by the Parisian fair sex, from the most refined ladies to the poorest among the work girls. We need not enquire into the various causes of this craze; but it must be acknowledged that the fashion is a very pretty one. At the opera we have seen several of these flowers made of diamonds; but the loveliest consisted of a gathering of dark rubies. We have noticed also some very bewitching fans. One of them, in pale blue crape entirely besprinkled with brilliants, had a cluster of deep red pinks painted across it in the most artistic manner.

JASEUR.

quiet business that has been transacted during the past few weeks.

The Gorham Manufacturing Co.'s works on North Main street, were recently visited by quite a serious fire, and owing to a delay of fifteen minutes, considerable damage was done, the fire department not knowing the exact locality of the fire upon their arrival at the works. Later it was found that the fire had been burning probably from the time the works were closed at night until it burst through the roof and was discovered. It seems that it had to burn from the basement through several stories to the roof before it was seen. Secretary Lawton of the company considers it difficult to give an estimate of the loss, as in such cases where one sustains only a partial loss, the exact loss in figures cannot be given until the damage has been repaired, but if the different shops through which the fire passed are total losses then he thinks \$10,000 will cover the entire loss to the works; the insurance on the entire works is \$500,000. The last large fire which this company had occurred about ten years ago, when the flames broke out about seven o'clock in the morning in the photographers' room, causing a loss of about \$20,000. The striking of the alarm was done in a very peculiar manner, the box being a private one, located in one of the offices in the company's works and connected with all parts of the various buildings by a patent auxiliary system of alarm by which the box can be struck from twenty-five different stations by breaking a bit of glass and pressing on a button. The fire ate its way by one of these stations and fused the insulated wires together so that the circuit was closed with the regular box in the office. The works will probably not be long undergoing repairs, and the time is not far distant when the company will move in their new and elegant works which are now building in Elmwood. These new works will be so constructed that they will not burn.

Secretary Marcus W. Morton, of the Manufacturing Jewelers' Board of Trade, reports that the board of directors held twenty-four meetings the past year, eleven being regular, two adjourned, and eleven special, and that the business of the year had required much time and consideration at the hands of the members of the board, which had been promptly and cheerfully given, that during the year there had occurred sixteen failures in which the members of the board were interested and to the amount of \$65,095.22, as against \$155,860.71 the preceding year. The membership of the last annual report was..... 113

To which add new members added the past year..... 4
Reinstated..... 2

Less resigned 8; out of business 3; Dropped 1; and 1
expelled..... 13

Present membership..... 106

The factory of Fred. I. Marcy & Co. met with quite a flood the other day through the nozzle of a pipe being melted off by a flame of gas coming in contact with it. Loss \$150.

At the inauguration of the new city government Edwin Lowe was sworn in as alderman, and H. S. Dorchester and Silas H. Manchester as councilmen. All three are well known manufacturers and able representatives of the different wards in which they live.

P. W. Ellis, of Toronto, Canada, has been in the city the past week on business and has placed some very fine orders with the leading manufacturers. Mr. Ellis does the largest jobbing business of any house in Toronto, and his style of fair dealing with all is the key note to his well deserved success.

Wm. H. Bowers, of Cameron & Bowers, paid a business visit to North Attleboro last week, and found that the trade is appreciating their efforts to furnish all that is required in special wires of the latest patterns.

Mr. Davis, of the firm of Davis & Emerson, has been very much

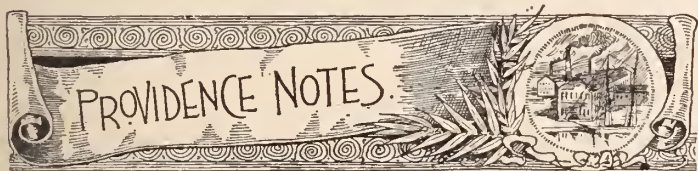

[FROM OUR SPECIAL CORRESPONDENT.]

PROVIDENCE, R. I., February 15, 1888.

The business for the year which started off with such bright prospects during the early part of the month of January, seems to have suddenly quieted down to almost nothing. Orders are not being duplicated to any great extent with the majority of manufacturers located here, not that the goods are not pretty in design and cheap in price, for they were never more so, but there seems to be some other reason for it all, though no one, so far as I have been able to ascertain, can give a satisfactory solution of it. The open winter may probably be the cause of it, as the business of the country generally is not up to the standard of one year ago, according to the reports of the business agencies located all over the United States. Collections, on the other hand, have been better if anything during the month past than they were a year ago, showing that the business done during the past six months has been of a conservative and profitable nature. Failures have become almost a dead letter in the

indisposed of late, but is now on the rapid road to recovery.

The Standard Button Fastener's works was visited by a \$300 fire on the night of the 11th. It was a "still alarm."

J. A. Brown now represents C. Cottier & Sons and Hahn & Co., dealers in diamonds and all kinds of precious stones.

Mrs. Alfred S. Potter has petitioned the Municipal Court to have Edward A. Potter appointed administrator of her late husband's estate.

The following named jewelers are represented amongst the board of directors of some of the national banks of this city as their last annual election will show: Isaac M. Potter, Commercial; John M. Buffinton, C. Sydney Smith, Roger Williams, and Henry P. Richmond, Atlantic National.

"On Dit" that Col. Isaac M. Potter, of Potter & Buffinton, is spoken of in regard to the coming gubernatorial contest.

Secretary Morton, of the Manufacturing Jewelers' Board of Trade, has the sympathy of all with whom he is acquainted in the loss of his mother, who died on Thursday, Jan. 24th, at Lubec, Maine.

The will of the late Frank E. Capron who died on Jan. 13th, has been presented for probate.

Joseph Fanning has been elected President of the Society for the Prevention of Cruelty to Children.

The famous "Goelet" cup won by the *Sachem* last season, has been on exhibition in this city for some time at the establishment of Tilden, Thurber & Co., on Westminster st. It is a beauty and valued at about \$1,200, and the owner of it may well feel proud.

N. S. Davis, of Davis & Emerson, has been elected Captain of the "Narragansett Boat Club" for the coming season.

Edwin W. Holden, of No. 38 Friendship st., met with a sad loss on the 15th ultimo, in the death of his infant son.

"Josh" Gray, the retail jeweler of No. 241 Westminster st., allowed the old worn out red pepper chestnut trick to be played on him recently to the extent of three gold watches valued at about \$75. He at once ran out of his shop and cried "stop thief!" and of course the fellow stopped and the consequence was that no one was able to tell who it was, whereas if the fellow had been allowed to run, it would have been very easy to tell who it was. The rather queer moral would seem to be in the future to let the thief run.

The following named officers have been elected in the "Providence Jewelers' Sick Benefit Association" for the coming year: President, Auton Mancher; Vice-President, A. Ohler; Fin. Sec'y, Chas. Mornier; Rec. Sec'y, Wm. Reinhardt; Treasurer, John B. Mueller.

Wm. L. Ballou & Co., will soon move into their new and commodious quarters in the new "Champlin Building" on Chestnut street, where they will be very comfortably located.

John Hoagland & Co., the well-known gold pen and pencil makers, are doing a lively business and are fast coming to the front.

Foster & Bailey stand in the front rank in their line as the immense sales of their celebrated "Omega" cuff button testify. It is the most popular button in the market to-day, and has fairly outdone their former leader the "Mount Hope."

Wm. H. Luther & Son report business in a healthy state, and have no reason to complain for want of orders as cheap goods are taking this season.

B. A. Ballou & Co., of No. 61 Peck street, have been making extensive alterations in their office.

The two cases of Jas. A. Charnley vs. Dodge & Adams which have been pending for four or five years in the United States Circuit Court, have been closed before Judges Colt and Carpenter. The decrees entered sustained the complainants' patents and held the defendants to be infringers of the same. The first case was for infringement on ornamental wire, the second for making the same.

The creditors located in this city, of Sigmund Stern of New York,

have received in settlement of their claims an offer of twenty-five cents on the dollar, viz; ten cents cash, and the balance secured. The agreement will most likely be accepted by the members of the Board of Trade as the best that they can realize under the circumstances.

At the annual ball of the Grand Lodge of Plumed Knights held recently the following named manufacturing jewelers were noticed: on the Honorary Committee, Col. Isaac M. Potter, Wm. H. Luther, John M. Buffinton, and Fred I. Marcy, and on the Reception Committee, Grand Commander Isaac L. Goff, H. F. Colwell, and John T. Mauran.

The Board of Trade has received notice from the Kellar Jewelry Co., of Chicago, confessing judgment. Members of the Board of Trade are down for about \$5,500.

The co-partnership heretofore existing under the firm name of Dunham & Towne, was dissolved on the 12th inst., Mr. Towne retiring. The business will in the future be carried on under the name of E. H. Dunham & Co

George Pitts has been confined at his home for some time, suffering from erysipelas of the face.

FAIRFAX.



A Lady's Rambles Among the Jewelers.

THERE are comparatively few novelties in the show cases of our retail dealers. Designers and manufacturers have hardly recovered from the demands made upon them for the holiday trade; and then our leading firms are occupied with preparations for the Paris Exposition.

* * * * *

THERE is always a lull between January first and Easter week. Shoppers after new things in the luxuries supplied by jewelers and silversmiths are less frequent, and consequently new productions, even if ready, are held back for a more propitious season.

* * * * *

THE PRINCIPAL demands made now on the retail dealers are such as come with weddings, christenings, birthdays and everyday affairs like dinners and receptions.

* * * * *

I AM assured on the best of authority that a little later on will be introduced some decidedly unique designs, and perhaps an unexpected innovation or two worth talking about.

* * * * *

ALTHOUGH there are not many decided novelties to describe this month there are a great number of very beautiful articles awaiting purchasers in all the leading stores; articles which bring credit to the manufacturers and offer to perspective buyers high artistic worth in addition to intrinsic value.

* * * * *

THE EFFECT of growing taste and emulation is apparent in all

directions, so that persons of educated perceptions have no longer any difficulty in making happy selections. Forms are more artistic than of old, and designs and decorations harmonize.

* * *

* * *

* * *

IN ILLUSTRATION of unique forms and artistic decorative work, may be cited the low flaring bowls of silver delicately etched and almost too beautiful to be hidden by even flowers. Sometimes these bowls have for handles twisted twigs or writhing serpents, and sometimes they have no handles at all. Not unfrequently they are wreathed with bands of gold. One buys them in a variety of sizes, and places them on the table wherever there may be room for the bloom of roses or the fragrance of violets.

* * *

* * *

* * *

LADIES who cannot afford the expense of silver flower bowls, select the same shapes and designs in crystal set in silver. This combination of glass and silver produces quite a charming effect.

* * *

* * *

* * *

ONE OF the most popular combinations in silver and glass, is represented by claret jugs of unique shapes with silver mountings. Occasionally one sees crystal claret jugs finished off with gold mountings.

* * *

* * *

* * *

GEM SET jewelry, much of which employs the colored stones now so popular, furnishes numerous instances in which good taste as to the proper harmonies and contrasts of colors, is observed. Colors are frequently used together which on first thought seem incongruous. Our jewelers have learned, however, that each color may be made to harmonize with every other, by changing tints and tones and gradually bringing these together.

* * *

* * *

* * *

MANY of the newest fashions in jewelry represent Renaissance, rococo and filigree designs all of which are at the front again as fashionable ornaments. Numbered with artistic specimens recently observed, is a rococo pendant enriched by four pearls, the largest of which is set in the center, the three remaining ones hanging as pendants.

* * *

* * *

* * *

A CHARMING pendant which may be worn also as a brooch, is of gold in Renaissance design, with an immense pear-shaped pearl swinging from a central point.

* * *

* * *

* * *

A FINE solitaire diamond recently set to order for a well-known New York lady of society, formed the central point of a Renaissance ring. This ring with its elaborate gold setting is in striking contrast with the almost invisible settings in common use for solitaire gems.

* * *

* * *

* * *

LADIES' watches continue small in size. Wide license is permitted in the selection of cases, every style being fashionable, from the plain gold case to that encrusted with jewels.

* * *

* * *

* * *

WHERE the gems used in the embellishment of watch cases are of

considerable size and fine in quality, they are set through the gold, not encrusted in it.

* * *

* * *

* * *

CHATELAINE watches are exceedingly fashionable and will remain so while the Directoire and Empire styles in ladies' dress prevails. These chatelaine watches are of gold or silver, according to the chatelaine with which they are worn. Some are of gold, elaborately ornamented with jewels, while others are of silver and are gem-set, enameled, or embellished with *repoussée* work.

* * *

* * *

* * *

THE Queen chain remains fashionable, though not to the exclusion of other styles. With quite new chains is numbered the Regency chain which, as the name suggests, is a reproduction. These chains are made both in gold and silver and are adapted to the fashion prevailing abroad just now of wearing the watch in a tiny pocket at the top of either a bodice or jacket. A stylish Regency chain is in silver with gold swivel, bars and buckle. The square pendant is of silver and there is a gold star in the center.

MANY of the open faced silver watches have gold hands and enameled numerals.

* * *

* * *

* * *

A CHATELAINE in enameled silver attracting attention, shows the design, on a black background, of a bird and flowers. The chains are of alternate silver and black enamel.

* * *

* * *

* * *

A NEW chatelaine is an antique chased silver. From the elaborate and floriated hook depend three chains, to one of which is suspended a silver watch, to another a silver pencil case, while on the remaining one hangs a silver backed note book.

* * *

* * *

* * *

A WATCH chain of recent introduction is in Etruscan style and follows pattern of the old fancy vest chain.

* * *

* * *

* * *

FOR men's wear are the fancy vest, the double chain and the fob chains

* * *

* * *

* * *

WATCHES for men tend to be flat and thin; many are open-faced. Monograms on watches run as a rule smaller than the elaborate ones of a few seasons ago.

* * *

* * *

* * *

LOCKETS and seals are the pendants preferred for men's chains. Queen chain pendants are restricted to no set pattern but include an inconceivable number of original designs among which figure blocks, balls, baskets, scissors, pigs, pencils, etc.

* * *

* * *

* * *

FOR LOVERS of massive and substantial ornaments the Torque bracelets, made of silver or plain gold, are to be recommended. These have no snaps but keep their place well on the arm, especially if worn over gloves, as is the fashion abroad. The Torque is com-

posed of four heavy circlets, one above the other, and so coiled at the top as to produce a center piece even wider than the bracelet.



A CHARMING brooch in old silver has a clasp ornamented with a Renaissance head in the mouth of which is held a silver shield which bears the wearer's monogram.



A BRACELET which, abroad, is termed the "fetich," is in bright silver, with a gold trefoil for an ornament.



A BRACELET of French origin, christened the "aumoniere," is a circlet of bright silver from which is suspended a small purse in old silver.



A UNIQUE bracelet in old silver is the ball bracelet. The small balls united by chains to form this bracelet are ornamented with fleur-de-lis. The chains uniting the balls terminate with a clasp taking the form of several balls.



THERE are some very pretty bracelets composed of square links of gold. The links in some instances are embellished with *repoussé* work and in others with jewels.



A NEAT and effective bracelet consists of a round circlet of gold held together on top with two-linked rings in platina. This is a fashionable combination of metals and is illustrated in brooches made to match the bracelets.



AN EFFECTIVE bracelet is a flat one of garnets in a heavy gold setting.



A SIMPLE and at the same time elegant bangle consists of a circle of gold wire with a sapphire set in filigree.



BRACELETS designed for convenience as well as ornament include the watch bracelets previously described, the pencil-case bangles and the ball-room bracelets which have suspended by a slender chain a clip in which to hold the dance programme.



ONE of the most artistic brooches seen this month was a perfectly round one, medium in size. The gold was wrought in filigree work. In the center was set a fine opal around which clustered at intervals tiny diamonds.



IN ENGLAND fine moonstones are receiving a little boom as lucky stones and the consequence is some very pretty brooches, cuff buttons and scarf pins in which the moonstone appears. A pretty moonstone brooch seen was in the form of a heart, the moonstone

being surrounded by brilliants which at the top of the heart look on the form of a true lover's knot.



AN effective monogram brooch consists of double initials in silver and small pearls.



A VERY pretty Louis XIV. brooch represents four trefoils in diamonds, mounted in silver, so as to assume a circular form.



A PLEASING circular brooch consists of a group of daisies in enamel set in silver.



A FLOWER brooch designed more especially for quite young ladies and consequently called by some jewelers the "ingenue," simulates a daisy which is studded with pearls.



CIRCLES of twisted gold links form a pleasing brooch in gold, as do three interlocking circles in Roman gold.



FOR ladies of quiet taste come all-gold brooches in oval form and embellished with applied wire work.



ANOTHER neat pin consists of three gold daisies placed in line on a short gold bar.



THE disc and crescent are both favorite designs in Russian enameled silver brooches.



THERE is a fad just now for what is termed "lucky" jewelry, in which hearts, wishbones, clover leaves, and similar objects are simulated.



ANOTHER moonstone brooch consists of a heart with a gem-encrusted dove on either side.



A STYLE of brooch in favor for presents to bridesmaids is a diamond brooch which simulates a horse-shoe slipped through the interstices of a true lover's knot, and indicates the "luck that love finds ever."



ANOTHER brooch especially designed for a wedding present is also of diamonds set so as to represent a true lover's knot tied about a heart. In the words of an old motto, "This knot of gold a heart doth hold."



To the making of ornamental hairpins there appears to be no end.

There are tiaras, combs, and decorative pins of every description. If all one hears may be believed there was a unique entertainment in Paris not long ago called a "bird's head dinner." Each guest wore a coiffure representing the head of some bird, as an owl, a turtle dove or a swallow. The most elegant, it is said, was that of a peacock with crest represented by an aigrette in diamonds, emeralds and sapphires.

* * * * * *

SPRAY brooches, and floral brooches are as fashionable as ever.

* * * * * *

SCARF Pins are universally worn. A cluster of gems, some fanciful design, floral patterns and fly pins, are all included.

* * * * * *

THERE is a tendency to silver scarf pins, especially those of dull silver set with a single fine gem.

* * * * * *

WHERE money is no object the diamond tiara naturally attracts patronage. One set in silver, seen recently, employed over 400 brilliants and 15 pearls of finest quality. It is needless to say that it presented a most *recherché* effect.

* * * * * *

COMING down to more everyday affairs, are tortoise shell small combs with decorative gold tops and with gem-set tops.

* * * * * *

HAIRPINS surmounted by twists of dead gold, with and without gems, remain popular, as do the ball hairpins, flower hairpins and fly pins.

* * * * * *

AN EXCEEDINGLY effective comb is of tortoise shell with a high top of faceted silver.

* * * * * *

FINGER rings are varied beyond precedent. There are rings with diamonds, solitaire and in clusters, and rings with diamonds in association with colored gems.

* * * * * *

AS IN other personal ornaments, there is no stereotyped style for finger rings. Solitaires, round clusters, gems set in square shapes or in a Marquise medallion, are all equally fashionable. The same remark holds true where the gems are placed in diagonal lines or in a straight row around the finger.

* * * * * *

IN SILVERWARE for the table forms remain for the most part low and flaring.

* * * * * *

A POPULAR style in silver table ware is a combination of the bright finish with chased work. In illustration may be cited a tea service in which the bodies of the pieces were quite plain but finished with

a border of oxidized silver chasing in floral patterns. Floral patterns, by the way, are favorites in silverware.

* * * * * *

SILVER toilet articles are embellished in a variety of ways in which *repoussé* figures conspicuously.

* * * * * *

SOME very pretty effects are gained in toilet articles made in bright finish with open work and pierced borders; also bright finish and chased work.

* * * * * *

THE SILVER trays introduced in the holiday season for receiving manicure articles and lined with plush or velvet, appear to have pleased the public. Newer than these are trays in *repoussé* silver with smooth grooves at stated distances in which to place the manicure implements. Some of these trays are quite large, having a sufficient number of grooves to receive an entire manicure set. Others are smaller, as for instance one made to accommodate three pieces only, a silver handled polisher and two little boxes for holding powder. One of the latter seen was ornamented with etching and lightly oxidized.

* * * * * *

THE fancy for decorative frames continues. Those for photographs and calendars being especially desirable. These frames come in both silver and gold and are frequently studded with semi-precious stones. Occasionally these frames are enameled. Numbered with the newer styles are those showing rococo effects.

* * * * * *

MEXICAN onyx, one of the handsomest as well as lowest priced of ornamental stones, is made up in many pretty small things such as jewel boxes, photograph frames, paper weights and inkstands.

* * * * * *

THE demand for enamel continues. The transparent enamel appears for the wings of insects, petals of flowers, etc. The opaque enamels are in great request, especially in floral jewelry.

* * * * * *

LEATHER goods with gold and silver mountings are now considered standard articles in the jeweler's stock. Change is noted in the making of pocketbooks in the tendency to the square shape.

* * * * * *

A UNIQUE card recently noticed was embellished with small diamonds set to simulate a crescent in one corner and tiny stars at irregular intervals over the surface of the case.

ELSIE BEE.

A CARPET OF DIAMONDS AND PEARLS.—Mr. W. S. Crane writes from India of his visit to the Maharajah of Baroda. "We were," he says, "taken to the old palace, in the heart of the city, to see the treasure room. Two huge cheetahs, carefully muzzled, were on the palace steps, used for hunting bucks. The regalia of Baroda is valued at £3,000,000 sterling. We were first shown the jewels worn by the Maharajah on State occasions. These consist of a gorgeous

collar of 500 diamonds, some of them as big as walnuts, arranged in five rows, surrounded by a top and bottom row of emeralds, the same size; the pendant is a famous diamond called 'The Star of the Deacon.' An aigrette to match is worn in the turban; then followed strings of pearls of perfect roundness. Wondrous rings, necklaces, clusters of sapphires and rubies, as big as grapes; and, greatest marvel of all, a carpet, about ten feet by six, made entirely of strings of pure and colored pearls, with the great central and corner circles of diamonds. This carpet took three years to make, and cost £200,000. This was one of Kliando Rao's mad freaks, and was intended to be sent to Mecca to please a Mahometan lady who had fascinated him, but the scandal of such a thing being done by a Hindoo prince was too serious, and it never left Baroda.

Practical Philanthropy.



WHILE THE poor and hard-working classes in the country are continually denouncing their more fortunate fellow-citizens who possess abundance of wealth, and are even attempting to organize aggressive measures against capital, the rich men are persistently seeking the means whereby they can benefit those who have not been favored by fortune. Every great charity known to us, every benevolent institution that is caring for the poor, the sick, the maimed and the deformed, our institutions of learning, and, in fact, every great and progressive work in the interests of humanity was conceived or is maintained by the rich men among our citizens. Public institutions are, in the main, supported by general taxation, but if the assistance given to these and to private institutions of a similar nature by our rich men were withdrawn, the burden of taxation that would be imposed upon the general public would be too great to be borne, and hundreds of these charities would be forced to close their doors for the lack of means to maintain them.

We are led to these remarks by observing that a Mr. Hand, of Connecticut, has recently donated a million of dollars and upwards for the education of colored children in the South. This gift is peculiarly appropriate, for Mr. Hand, previous to the war, was in business at Charleston. Being a Union man, he was obliged to fly to the North, leaving his affairs in the hands of a young man who had been his assistant. Under his management the business continued to prosper during the war, until the young man had become extremely wealthy. About a year ago he came North in search of Mr. Hand, and having found him, accounted to him for his share of the profits of the business, paying over to him more than a million of dollars. Mr. Hand now restores this money to the South, where it was accumulated, by providing for the education of the rising generation of a class that has always been a troublesome element because of the dense ignorance that has pervaded it. Close upon this act of benevolence, the report comes from Philadelphia that Mr. J. V. Williamson, of that city, a wealthy gentleman whose life has been devoted to good works, has decided to devote \$12,000,000 to the establishment of industrial schools and homes for poor children in that city. He has named a number of prominent gentlemen to constitute a board of control, and these recently held a meeting and permanently organized. Owing to his advanced age, Mr. Williamson felt the necessity of confiding the general execution of his plan to younger men, but he had previously clearly decided in his own mind the methods to be adopted to accomplish his object, and had the plans of the necessary buildings prepared by an architect. His plan is to erect an industrial school on a large scale, to be composed of numerous buildings wherein poor boys can learn trades or useful occupations, and so become self-supporting at an early age. Such of them as are homeless will be provided for within the institution. The scheme will be pushed to completion as speedily as possible, that the venerable philanthropist may see the fruits of his benefaction before

he dies. Charity could take no more philanthropic and practical direction than this. Education and industrial training are the great alleviators of poverty and distress. A boy brought up in ignorance and without having learned a trade, is apt to become vicious and a menace to the peace of the community in which he lives. Workingmen never made a greater mistake than when they permitted their trade unions to discourage the employment of apprentices. As a consequence of that action the cities to-day are overflowing with young roughs and rowdies, and with "gangs" of ruffians organized for plunder and pillage. Forced, from lack of employment, to run the streets, boys soon become the hangers on of the liquor saloons, and ripe for mischief or for crime. It is a disgrace to our civilization that stalwart young men are to be encountered at almost every corner begging for pennies, when skilled labor is in demand almost everywhere. But these unfortunates have not the skilled labor to sell because the trades unions have shut them out of the factories and the workshops. It is not, as a rule, the fault of the boys that they do not know some useful calling, for most boys are ambitious and only too anxious to earn money, but the opportunity is denied them until idle and vicious habits have been acquired and then it is too late.

In several European countries the government has established training schools in numerous branches of industry, among them that of watchmaking. These horological schools have been highly successful, turning out skilled workmen who have been a credit to their teachers and to themselves. The example might well be followed by the several States of this country. In the absence of State industrial schools, too much credit cannot be given to such philanthropists as the late Peter Cooper, founder of industrial schools in this city, to Mr. Williamson, of Philadelphia, and many others who have done and are doing all in their power to supply the deficiency.

Clocks as Ear Pendants.



IN THE perusal of old writings and documents the student occasionally reads of strange whims and fancies evinced by those of both high and low degree. It is well known that Emperor Charles V., who almost commanded the world, was a skilful watchmaker, and, after his dedication, in 1556, retired to the Spanish monastery of St. Just and occupied himself with watch and clock making and other mechanical pursuits.

When recently reading a rare old French manuscript the translator of THE CIRCULAR learned that Charles V. used to wear a handsome little striking clock as an ear pendant. This fact was stated in the copy of a letter which is quoted, dated Paris, December 1, 1610, bearing the signature of the Netherland Secretary of Embassy, Simon. As is known at this time Archduke Albrecht of Austria was Governor of the Netherlands, and he, together with his wife, Infanta Isabella, had a great love for mechanical works of art and rarities. Among other things these high personages also desired to have two striking clocks of the smallest size obtainable, according to the custom of that age, and they commissioned their Ambassador in Paris to either find them or order them to be made.

By means of the assistance of friends the Secretary, Simon, became acquainted with a first-class watchmaker in Paris. This mechanic, however, told him in a few words that the genius had not been born yet who could make two such small striking clocks. Whatever of the kind was offered in the stores of Paris was unreliable, of doubtful value and nothing else than toys, "similar to that striking clock worn by His Majesty Charles V. as ear pendants," or, to give the old French, *Comme Charles V., que en portoit une a son oreille pour pendant dicelle.*

We hereby learn how far the Emperor's love for watches went. The Secretary finally succeeded in inducing the watchmaker to make

the clocks, the latter stipulating, however, that he gave no guarantee for their correct rate, and for the price of 70 livres per clock. But it appears that the honorable artisan repented of his bargain, because on December 4 the Secretary was "very sorry to be compelled to report that the watchmaker had backed out, saying that he did not intend to deceive either rich or poor and make the clocks, as he knew well before hand that they would be pieces of botchwork, which would disgrace him and his name forever." The Archduke did not relinquish in his endeavors, because after great trouble, in November, 1611, two miniature clocks were sent to him, made by another watchmaker in Paris, for the price of 297 livres and 2 sous.

How to Test for Magnetism,

In Watches, in the Shop, on the Cars, and on the Person.

BY "EXCELSIOR."

[Owing to an error of the printer the article on "How to Test for Magnetism," by "Excelsior," which appeared in the February number of THE CIRCULAR, was improperly made up in the page, causing a number of lacunæ to break its continuity. The subject seemed of sufficient importance to warrant us in reprinting it again entire in this number, and it is accordingly appended.—ED.]



HERE seems to be a tendency in some quarters to underestimate the injurious effects of magnetism upon the performance of watches—to make out that there is but little danger of a watch becoming magnetized, and so on. These ideas are so very far from being correct that I have felt impelled to give the trade the benefit of my experience in that line. I do not propose to write a theoretical disquisition on electricity and magnetism, but to tell practical workmen in a plain, practical way how they can make some simple "testers," at a cost of a few cents for materials, by which they can test for them-

selves any watch or any part of it, and can also ascertain whether there is any magnet in its vicinity acting upon it.

But first, a few words about the prevalence of magnetism and its effects. Many persons think that a watch will not become magnetized unless it is exposed to a powerful dynamo, which will seldom occur, so that they may as well run their chances and not bother themselves about non-magnetic watches or devices. This is a great mistake. Taking into account all the watches in use, good and poor, new and old, it is doubtful whether there are as many as *two out of a hundred* free from magnetism. Does this seem startling? Think for a moment, and you will see that they may be magnetized when they come from the factory, unless special pains are taken to prevent it. The tools and machines with which they are manufactured may be magnetized, and the various steel parts may become so even after they are finished—in putting up, adjusting, etc. Then they pass through the hands of the agents, jobbers and dealers, with all the risks of exposure during the packing, selling and shipping here and there, until they finally come to be examined or "overhauled" in the retail dealer's shop.

And how is it there? I have worked in and visited a good many shops, east and west, and I candidly doubt whether there are a dozen repair shops in the country where the bench tools and the stock of materials are free from magnetism. Who has not seen the familiar "horseshoe magnet" lying on the bench among the tools; or kept in

the material drawers in actual contact with the mainsprings, or case springs, or watch keys, etc.; or used for picking some lost steel piece out of the dust heap? In the old days nobody thought there was any harm in that—and very few fully appreciate the harm of it even now. Yet the fact is that each magnetized piece magnetizes every other piece that it touches, till all are more or less affected, and every watch handled with magnetized tools is contaminated. Actual contact is not necessary, for a magnet will magnetize a piece of iron or steel *near it* by "influence." As the watch hangs on the rack or lies in the show case it is influenced by every magnetized piece in its vicinity, according to their distance and the strength of their magnetism. Every screw, nail, or piece of iron or steel, the locks, the sash weights, even the safe in which it is kept nights, may be magnetized, and will not only affect the running of the watch but will surely magnetize it. Instead of their being but little danger of the watch being exposed to magnetic influences, the trouble is to find a place which is *free* from them.

A watch which is magnetized will be affected by *every piece of iron or steel* which comes near it, even if the latter is *not magnetized*. Let us see how that can be so. I cannot here explain fully the principles of magnetic action which are concerned in this case, for that alone would require one or two entire articles, and the following brief statement must suffice for the present. I may return to this subject at some future time. My remarks will refer to ordinary watches, not provided with any protecting devices for magnetism. A discussion of the different anti-magnetic inventions would involve personalities and be foreign to our present purpose, which is a general explanation of the whole subject, not the treatment of special and exceptional cases. In speaking of the "parts" of a watch, I mean those made of magnetic metal and therefore liable to be magnetized. Those of iron and steel are the most so, nickle is slightly magnetic, cobalt, aluminum and platinum are less so, and copper, brass, zinc, gold, silver, glass and paper not at all.

Whether the watch is magnetized or not, it will be affected by any magnet in its vicinity. If it is free from magnetism it will not be affected *so much* as if it were magnetized, but the difference is less than might be expected, for this reason: it *becomes* magnetized when the magnet approaches it, even if it was not so before. A piece of iron or steel when exposed to a magnet becomes "magnetized," and while so magnetized *it is a magnet*. A watch cannot be exposed to magnetic influence without being affected thereby, that is to say, it will *necessarily* be magnetized. Those parts of it which are made of perfectly soft or annealed pure iron will lose their magnetism when magnetic influences are removed, *i. e.*, they are only temporarily magnetized. But those made of hard or impure iron, or steel, especially compressed or tempered steel, will retain more or less of their magnetism, even after all external magnetic influences are withdrawn, and every such part is then a "permanent magnet," with its north and south poles and magnetizing powers, acting upon the other parts according to its strength, position and distance. As a necessary consequence, if a single part in a watch is permanently magnetized, the other parts will be *kept magnetized* by it. Thus a magnetized mainspring, case spring, pinion, or even a screw, may contaminate the entire watch.

Hardened and tempered steel is less easily magnetized than soft steel, but, on the other hand, it retains its magnetism longer and more tenaciously. When magnetized to a certain strength, it will retain the polarities so produced in it, as against a weaker magnet which tends to produce the opposite polarities in it; whereas, a softer piece exposed to the same conditions might have its polarity reversed thereby. A very soft piece will have a polarity according to every magnetic pole presented to it, and may reverse its polarity hundreds of times in a day. And while it might be *possible* to regulate a magnetized watch, if its condition would remain unchanged it is evidently out of the question to regulate a watch which is liable to be radically changed every hour, minute or second in the day. This is not an improbable occurrence but an ever-present danger, for

every one knows that the steel of the balance is comparatively soft, and of all the parts in the watch that is the one which *must* be protected from magnetic disturbances if we want a decent performance, or any performance at all.

As before stated, a magnet can magnetize a piece of steel or iron both by contact and without contact. In the latter case it is said to magnetize by "influence," *i. e.*, at a greater or less distance from it. Some powerful dynamos are said to magnetize a watch twenty feet away. Electric motors act like dynamos in that respect. Weaker magnets produce less effect, but even a little hand magnet can be felt several feet, and every piece of iron or steel within the circle of its influence is at least temporarily magnetized, *i. e.*, it becomes a mag-

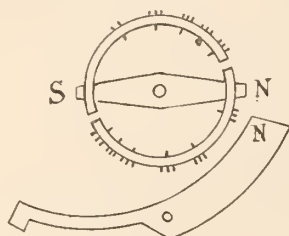

FIG. 1.

net. The different portions of a magnet have different properties or polarities, and, to distinguish them, are called north and south "poles." The poles are generally at or near the ends of the piece. But in case of a long piece or a ring there may be several poles. Thus a balance may have a north pole at one end of the center bar and a south pole at the other end. The poles may be located somewhere else in the rim, or there may be several poles around the rim. In a long piece like a mainspring, there may be a considerable number of poles, alternately north and south, around it. A north end or pole will repel another north pole, but attract a south pole, *i. e.*, "like poles repel but unlike poles attract each other."

Magnetism is the most injurious in watches when it affects the balance, for that is the part whose motion is most easily disturbed and most desirable *not* to disturb. Magnetic attraction upon parts outside of the escapement is of very little consequence, but *their* magnetic action upon the balance is very important indeed.

Now just imagine a magnetized balance vibrating one-eighth of an inch (or less) from a magnetized case spring, or balance cock screw, or center pinion, or any other steel piece, as shown in fig. 1, which represents the simplest possible case, where the balance has but two poles, N and S. Whenever the N part of the rim approaches the N end of the case spring it is retarded or opposed, but after passing the end of the case spring it is driven forward or accelerated by the repulsion of the latter. When the S point of the rim approaches, it is attracted and pulled forward, but, after passing the case spring the attraction of the latter holds it back. These disturbances are most energetic, of course, when the poles of the two pieces are passing, and nearest together. The number of times these accelerating and retarding actions take place in each vibration of the balance will depend on the amplitude of the vibration and the number and position of alternating polar points in the rim, and will evidently be different as the watch runs down more and more. It is not necessary to explain further, for everyone can mark out any combination of polar points he chooses, on the cut, and study out the effects for himself.

It is perfectly clear, however, that the balance cannot have that regularity of motion which is essential to timekeeping. Its motion is not controlled by the hair spring, as it should be, but by outside influences which are unknown, uncontrollable and constantly changing. Add to all this the disturbing effect of every iron or steel object you meet, acting now from one direction and next from some other, and what kind of time can one expect from such a watch? Even when the effect upon the motion of the balance is not perceptible to the eye, the errors in the running may be so large as to render it a matter of no consequence whether the watch is adjusted for

isochronism and temperatures or not, and the best expansion balance may act no better than one of plain steel. If the magnetism is at all powerful, the watch will stop.

Of course we cannot tell where the customer will wear his watch, but we can make sure that it is all right when it leaves our hands. Then if he comes back with a complaint about its running, we can test it again, and if he has exposed it to magnetic influences powerful enough to injure its running, it will show the effect of it by retaining more or less magnetism in its steel parts, which we can detect by our testing needles.

To make our testers we need only some soft iron wire, and some very flexible fiber to suspend our needles with. Fig. 2 shows a pair of needles suspended from the ends of two handles, which may be sticks of pegwood. When not in use the sticks may be stuck in a flat cork, for a "stand." The whole may be covered by a glass to keep the dust off, or put in a paper box.

For our suspension we may take some sewing silk twist, and separate it into fine filaments, or we may pull one out of a ribbon. The fiber should be sufficiently long and fine to have no stiffness or twist, and to allow the needle to *turn freely in any direction*.

For our needles we take some fine iron wire, say ordinary binding wire, somewhere about No. 20, or $\frac{1}{60}$ inch in diameter, and cut off two pieces about two inches long. These are for testing the shop, tools, etc. Then cut off two pieces of finer binding wire, one inch long, for testing watch parts for very feeble traces of magnetism. We have a pair of each size, for testing each other, that we may be sure that our needles are themselves free from magnetism. To distinguish the ends, we leave one end square and point the other. Get the needles straight and *finish all work* on them before annealing.

Anneal thoroughly, in any convenient way—for instance, heat two bricks red hot, put the needles on top of one, cover them with the other, cover the whole with coals and ashes and let the pile cool as slowly as possible. Two iron blocks may answer instead of bricks, or even two red hot pieces of charcoal, if need be.

When cool, tie the silk around the middle of each needle, and hang to some support, say pegwood for the short needles. The longer ones may have a foot of silk, and hang from a wire of brass

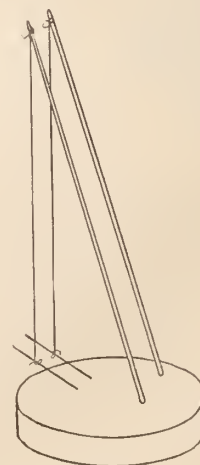

Fig 2

or other non-magnetic metal. If you *know* that your needles are of good iron and are properly annealed, they are now ready for use. But if you are not enough of an electrician to be sure of that, you will first

Test your needles. That may be done in different ways, but the following procedure will be simple and easy for the least experienced: Being sure that they are clean, *i. e.*, have no grease, moisture or dirt to make them stick together, hang the pair parallel, as seen in fig. 2, $\frac{1}{2}$ or $\frac{1}{4}$ inch apart, and see what they do. If they hang perfectly still and indifferent to each other, you are a fortunate man—"one among ten thousand," for you have got your needles right the first time, and have a shop free from magnetism—at least,

in that particular place. But they will probably attract each other and come together. There may be several reasons for this.

Static charge. In a dry atmosphere the needles may be electrified, or charged with electricity. If so, they will probably separate spontaneously in a moment. If they do not, gently press both needles between the *clean* thumb and finger, or touch them with a piece of non-magnetic metal; that will "discharge" them. If they still stick together, the attraction is not electrical, but magnetic.

Magnetic attraction between the needles may be due to their having been *permanently* magnetized by some magnet after the annealing, or they may be now under the "influence" of some magnet in their vicinity, *i. e.*, *temporarily* magnetized by it. In the former case the needles are not of pure iron, or not sufficiently annealed, or they have been *worked at* since the annealing. Hammering, filing, twisting or bending, may give even soft iron a little "coercive force," *i. e.*, power to retain magnetism. It is this force which enables tempered steel to retain so much magnetism and make such powerful magnets. We want none of it, and if our needles possess it they are not magnetism-detectors, but

Magnetized needles. They may be used to hunt after iron and steel, or to tell the polarity of magnetized pieces. Remembering that unlike poles attract each other, that part which is attracted by the north pole of a compass needle, or any other magnet, is a south pole. By holding such a needle over a balance and moving its point around the rim, its north pole will be attracted by those parts of the rim which are of south polarity and repelled by the north parts. Any other piece can be so tested.

Magnetism-detectors. A magnetized needle will point to any piece of iron or steel, whether it is magnetized or not. But that will not answer for our magnetism-detectors. We do not want to know whether there is any iron or steel in the watch, or on the bench, or elsewhere—for we can see it. What we want to ascertain is, whether that iron or steel is magnetized or not. Hence our needles must behave differently in the two cases: must be neutral or indifferent to metal which is not magnetized, and must be attracted to that which is, thus clearly pointing out to us which parts are magnetized and which are not. For practical working purposes, they must also be able to throw off all magnetism, or free themselves from it the moment that the external magnetic influences are removed, no matter how strongly or how often they have been magnetized, so that they may always be in working order. Only perfectly soft or annealed pure iron can do this, and even that must not be worked or compressed after annealing.

Test for permanent magnetism. Remove one of the needles and test the other with a permanent magnet—not a "horseshoe," but straight. A magnetized rod, nail, or even a knife blade, will do. Point the blade at your needle and bring it just near enough to cause one end of the needle to *point* steadily towards it, but *not* close enough to draw the needle towards it. Now turn your needle with its other end to the blade, with the fingers or a brass wire. If it is permanently magnetized, it will swing around to its former position; if only temporarily magnetized, it will point to the knife blade, *i. e.*, it will make no difference which end you present to the blade—either end will point to it, showing that the needle is properly made. But if one end points to the knife, and the other end is repelled by it and turns from it, that needle is either not sufficiently annealed or not pure iron. Anneal it thoroughly, then rub the point of a magnet gently over it from one end to the other, and test again. If one end is still attracted while the other turns away, as before, that iron is not suitable for our detectors. But if *either end* will now *point* to the magnet as above described, your needle is ready to use; and if two such needles will hang near each other (say $\frac{3}{4}$ the length of a needle apart) and not be attracted, you may conclude that there is no magnetism in their vicinity, at least not enough to do the slightest harm.

Test for concealed or unknown magnets. Remove all known magnets to a distance. If the needles then swing around till their ends meet (as shown in fig. 3) and stick together, there is still some mag-

net in their vicinity. As before stated, a magnet exerts what we term a magnetic "influence" in the space near it, or we may say that it fills the space around it with magnetism. This external or free magnetism will go through water, air, wood, paper, glass, metals, live flesh and blood—through anything whatever. Nothing can stop it. The space so affected is called a "magnetic field." So every magnetized tool or object produces its magnetic field around it and every other piece of magnetic metal in that field is magnetized by it, according to the strength of the field acting upon it. It is this unseen influence which affects our detector needles and enables us to detect its source.

In fig. 3, the dotted lines may represent the position of the needles when unaffected by magnetism and swinging freely, as in fig. 2. When magnetism is present they become magnetized, opposite poles attract each other, and they assume the position shown by the full lines. The needles are greatly exaggerated in thickness in the cut, for the sake of clearness.

Testing the tools, shop, etc. To do this we let one of our large needles hang over the suspected tools, close to but not touching them, and move it slowly around till it shows a disposition to *point* at a particular spot. Let it down till the end touches the spot, and if it sticks to it that part is magnetized. Remove all such pieces as fast as found, till none remains. If our needle still *points* in one direction, when allowed to hang freely, there is magnetism "in the air," proceeding from some more distant magnet. To find it, move the

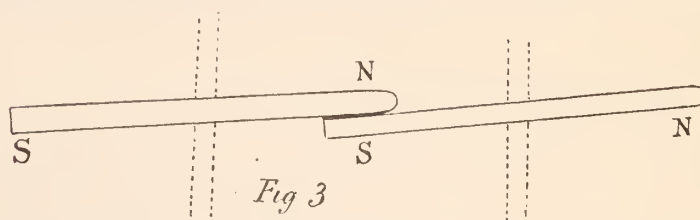

needle *straight forward* in the direction it points, till you come to the magnet. If the needle, when so moved, ceases to *point*, put it back again, let it point, and move it in the opposite direction, *i. e.*, the other end forward. The needle does not necessarily point *towards* the magnet which is acting upon it—it may have almost every position, even *at right angles* to the direction of the magnet from it, if distant. But if moved straight ahead in the line of its axis, as described, it will gradually turn and finally reach the magnet. Electrically speaking, it follows along the "lines of force" to the magnet.

Testing railroad cars, locomotives, tracks, streets, stores, and other places, can be done in the same way, to satisfy yourselves how omnipresent magnetism really is. But as the magnetism we look for in such places is generally quite strong, it will not be necessary to have your needles suspended, but throw them loose, without the silk, into a small paper box twice the length of a needle, and shake them together. If they are in a "magnetic field" they will stick together, but if they are not under magnetic "influence" they will have no attraction for each other. One will be surprised to find how universally iron and steel objects are magnetized. Lamp posts, fire irons, lightning conductors, water and gas pipes, gates, railings, iron pillars, and supports, and all objects which remain for a long time in an upright position, are magnetized by the earth's magnetism, with their north pole downward. They in turn magnetize other objects, in horizontal or other positions, by contact and by "influence." Then there are the dynamos, electric motors, conductors carrying strong electric currents, telegraph and other magnets, telephones, electric fire, burglar and other alarms, and the thousand-and-one other magnetic appliances in common use, all producing magnetic fields around them. The tendency is for all magnetic substances to become more or less magnetized, and it is difficult for one to go anywhere without meeting magnetic "influence."

Test yourself, before making any of the other tests described in this article, to be sure that you have no magnets about your person

while testing, as they would destroy the value of all your tests. Swing a needle slowly over the person, near to it. If it shows a tendency to *point*, move it more slowly from side to side before that spot, and it will turn itself to point at any magnetic object there. You can thus detect a magnetized artificial limb, truss, revolver, knife, bunch of keys, button hook, spectacles, etc. Even the buckles and buttons may be magnetized. Electricians have always known the necessity of removing all magnets from the person before testing, but it is probably new to watchmakers.

Testing a watch. Having now a place free from magnetism, you are ready to test your watches. First lay your suspected watch (case and all) under or near the suspended needles (fig. 2) till you have leisure. If the needles stick together, as in fig. 3, the watch is magnetized, and should be put into the demagnetizer at once. If you wish to test the parts separately, swing one of your short needles over the movement, and let it down till the end touches the suspected part—for instance, the balance rim. Then gently lift it up, and if they do not stick together at all, touch other parts of the rim, then touch the other end to the rim. If there is no attraction between them, anywhere, the balance is not magnetized. In the same way you can test the other parts, or your material, before fitting in a new piece. If one part in a watch is magnetized, all the others will be more or less affected, and the whole should be demagnetized together, case and all, just as it stands.

To satisfy yourself or your customer that a magnetized balance is affected by every piece of iron or steel which comes near it, hold a piece of soft iron, free from magnetism, near it and observe the effect.

Test the customer. When you have got the watch free from magnetism, you can test the owner, to see if he is properly qualified to carry such a watch without injuring it. If you have a sense of humor you can make considerable amusement by telling him about your pointers and setters, bringing out your detectors, and searching him for concealed magnets. It is essential not only to do good work but to have your patrons satisfied and good natured, and a little innocent fun of this kind may do you more good than long arguments and explanations.



[FROM OUR SPECIAL CORRESPONDENT.]

THE HUB IN MOTION.

BOSTON, February 16, 1889.

The E. Howard Watch and Clock Company held its annual meeting on the 11th of February, and re-elected the following officers for the ensuing year: President, Samuel Little; General Manager, Albert Howard; Treasurer, Chas. G. Hayden. The old board of trustees were also re-elected.

Wm. H. Ferris has opened a jewelry store at 1,441 Dorchester avenue.

Clough & Hardy is the title of a new manufacturing and repairing firm at 2 Province Court. John B. Clough used to work for Margat Bros., while Freeman B. Hardy learned his trade in Brooklyn, N. Y.

Shreve, Crump & Low believe the crook "Harkins," alias Hollis, alias Bestiner, who robbed Edwin Kennedy in a New York opium joint, to be the man who stole their diamonds some time ago.

J. Rosenkranz, at 2,201 Washington street, and Henry de Young, at 299 Tremont street, both closed out their stocks of watches and diamonds at public auction last month.

The outdoor show case of S. W. Bailey, at 353 Washington street, was recently robbed of several hundred dollars' worth of opera glasses and spectacles.

More than three-quarters of all the spectacles and eye-glasses made in America come from the factories at Southbridge, Mass. One concern alone turned out a million and a half pairs last year.

Shreve, Crump & Low have again been unfortunate. A box containing eighteen solid silver imported picture frames, worth \$80, was stolen from an express wagon. Three Italians were arrested.

Chas. H. Pratt is the assignee in the Bragan insolvency case.

A jewelry branch has been added to the furnishing goods business of Wm. H. Murphy, at 9 Hanover street.

A new \$40,000 apartment house will soon be built by jeweler Edwin B. Horn in Newbury street.

The new store of Houghton & Dutton contains an extensive silverware department.

The late B. E. Shaw's estate inventoried \$5,908.24. That of Francis T. Bemis, who was a partner in the firm of Bigelow, Kennard & Co., \$9,400 real, and \$17,091.58 personal.

Speculation is said to have caused the failure of Louis J. Wyman, of the diamond and jewelry firm of Rand & Wyman. The liabilities are \$8,841.67, with scarcely any tangible assets.

Sumner Bros., of Marblehead, are reported to have lost \$8,000 in the recent conflagration. The insurance is less than \$5,000.

When Charles Moore, long foreman in the dial department of the Waltham factory, retired from the works recently, his associates tendered him a grand reception at the James' Opera House. He was presented with an ebony cane and diamond stud.

The creditors of William J. Dinsmore have had their anxiety allayed by an announcement that his suspension will not prevent the settlement of his liabilities at par.

If the claims of the Electric Gold and Silver Chlorination Company are substantiated, there will be a revolution in the process of working ores. The company has opened an office at 146 Franklin street; Edward Howard, of watch and clock fame, is the Treasurer. The patents are said to insure a reduction in the expense of electric chlorination.

G. A. Kelly, an installment agent for H. M. Kimports, has been arrested on a charge of embezzling a dozen clocks, worth \$100, at Saccarappa, Me.

Harry A. Newton, formerly an employee of the American Waltham Watch Co., who has been doing business for the last three years at Bourne, Mass., died recently from alcoholism. He was found dead in his shop.

Isidore Warshauer will assume the liabilities, collect the debts and carry on the business hitherto shared with him by Max Newman, on West Broadway, South Boston.

Nelson H. Brown has occupied his new quarters at 90 Franklin street. Harwood Bros. are his partners in the clock business.

Wm. E. Leavitt has gone out of the jewelry business.

Wm. B. Knapp, who was the manager of the diamond branch of Dr. George E. Lothrop, concerning whose embarrassment I wrote you a month ago, has started in for himself at 74 Tremont street. He will cater for the theatrical profession.

John A. Remick will again go abroad with his wife in March. The couple will attend the Paris Exposition and make purchases of rare gems and works of art in all the foreign capitals.

A circular issued by M. H. Downes, announces that he has started a practical school of watchmaking at 7 Bosworth street.

Henry N. Fisher, one of the foremen of the American Waltham Watch Co., is the Mayor of Waltham.

A. T. Morrill, of the firm of Morrill Brothers & Co., who arrived

recently from Europe, has taken winter apartments with his bride at the Adams House.

The new "Boston Tavern" was furnished with its silverware by the Gorham Manufacturing Company, of New York.

The twenty-first birthday of Arthur M. Little, son of the President of the E. Howard Watch and Clock Company, was recently celebrated at the family residence, 556 Warren street. The young man is a senior at Harvard.

Horace Partridge & Co., wholesalers, will give up their Hanover street store on July 1, and move into the new Lincoln street building of Hon. F. Z. Ames.

Many of Wm. J. Dinsmore's creditors have already granted him an extension.

The third annual dinner of the Foremen's Association of the E. Howard Watch and Clock Company, was given at the Quincy House on Saturday evening, January 19. About thirty members were present. They entertained as their guests the following officers of the company: President Samuel Little, Treasurer Charles J. Hayden, Director and General Manager Albert Howard, Directors Charles M. Clapp and William H. West, Superintendent William B. Larned of the watch department, and Superintendent Rufus B. Carr of the clock department, President John Halden of the association presiding and being toastmaster of the occasion. After being welcomed by President Halden, speeches were made by the guests and some of the members of the association, the general tenor of which was indicative of the utmost harmony existing between the management and the members of the association. The formal exercises of the evening were brought to a close by the singing of "Auld Lang Syne" by the assembled company.

The store of manufacturer Eugene Richards was slightly damaged by fire on the morning of January 23.

D. J. Dannahy & Co. is the name of a new firm of which David J. Dannahy, who was with Robbins, Appleton & Co., agents for the American Waltham Watch Co., for sixteen years, and with Geo. H. Richards, Jr., for the past seven, and Jonas R. Laws, also with Geo. H. Richards for 11 years, are the partners. They have begun business at 12 West street, with an elaborate assortment in all the jewelry lines.

Wm. J. Dinsmore and Ezra M. Crawford have dissolved partnership.

C. W. Maxfield and Albert H. Curtis were arrested late last month for burning their stock to obtain \$300 insurance from the German-American Insurance Co.

Palmer, Bachelder & Co. have removed to 143 Tremont street. The mortgage on their stock has been discharged. LEON.

New York Jewelers' Board of Trade.

FOURTH ANNUAL MEETING.—WAR DECLARED ON THE PAWNBROKERS —REPORTS AND ELECTION OF OFFICERS.—PREPARATIONS FOR THE FIRST ANNUAL BANQUET.



THE NEW YORK Jewelers' Board of Trade held its fourth annual meeting at the rooms of the Board on the afternoon of January 29. The following members were represented: Veuve L. B. Citroen & Co., Downing & Keller, M. Fox & Co., Max Freund & Co., Heller & Bardel, Louis Herzog & Co., L. & M. Kahn & Co., Keller & Untermeyer, Chas. Knapp, C. G. Rochat & Co., Levy, Dreyfus & Co., Sol. Lindenborn, Lissauer & Sondheim, Henry May, S. F. Myers & Co., Oppenheimer Brothers & Veith, H. E. Oppenheimer & Co., Pforzheimer, Keller & Co., Enos Richardson & Co., M. D. Rothschild, Adolphe Schwob, Simpson, Hall, Miller & Co., Sinnock & Sherrill, W. Smith & Co., Stern & Stern, Stern Brothers & Co., Sussfeld, Lorsch & Co., Wiggers & Froelick.

After the reading of the minutes of the last annual meeting,

Secretary Condit presented the following report, which was unanimously adopted:

Mr. President, Officers and Members of the New York Jewelers' Board of Trade:

GENTLEMEN—Allow me to submit to you for your approval my annual report for the year ending January 1, 1889. On January 1, 1888, we had a membership of eighty-six, to-day we have a membership of eighty-nine, showing a slight increase. This fact, when taking into consideration that at the last annual meeting it was found necessary to increase the dues, plainly demonstrates the compact manner in which our members have stood together, showing they appreciate the value and necessity of having a representative trade organization.

On January 1, 1888, we had a record of the financial standing of 7,115 dealers, in the trade. Since that date 1,954 new names have been added, making a total of 9,069 dealers whom we can now report upon.

3,107 trade inquiries have been made of members by canvasser; 1,153 of these being revisions of dealers whom we previously had record of and the balance new names.

8,180 reports have been made to members; 3,578 being compiled from correspondents' reports and statements.

2,879 reports have been written for to correspondents.

2,156 reports have been received from correspondents.

4,399 requests for statements have been sent to dealers or personally applied for in this city.

1,321 statements have been received.

8,985 weekly and special information circulars have been sent out during the year.

To this department we call the special attention of members who have made little or no use of it in the past, omitting to give it a fair test of the benefits that accrue from it, and in many instances standing in their own light, and I would respectfully request them to make a trial of this department and we will do our utmost to supply their needs.

BUREAU OF COLLECTIONS.

On January 1, 1888, we had 342 claims on our records, amounting to. \$41,348.43
And during the year have received 526 claims for collection, amounting to..... 66,220.98

Making a total of 868 claims, aggregating..... 107,569.41
Which we have had in charge during the year.

339 claims have been sent to attorneys, aggregating.... 50,766.96

118 claims have been collected by attorneys, aggregating..... 14,084.50

37 have been collected by notice from this office, aggregating..... 2,865.66

53 have been settled direct, aggregating... 5,178.27

130 have been returned as uncollectable, aggregating..... 17,707.40

41 claims have been withdrawn, aggregating..... 8,016.17

111 drafts have been received, "..... 10,770.32

33 drafts have been honored, "..... 1,717.76

58 judgments have been obtained, "..... 10,006.72

12 judgments have been satisfied, "..... 1,112.34

253 total claims have been collected during the year, aggregating.... 24,958.53

We now have 489 claims on record, aggregating..... 59,627.41

111 of which are in judgment, "..... 22,609.78

To this department we call the attention of members who have not used the draft system. To these we would be pleased to explain its modus operandi, and many of our members can testify to its value as a collection medium. It seems to be the impression among some of our members that when claims are sent to the office for collection they are immediately reported on our weekly sheets as "Claims sent to attorney." This is a mistaken idea. Your Secretary is particular to take no step in such matters that would in any way jeopardize the interest of our clients. In connection with this department we have appointed attorneys in nearly all the large cities and towns throughout the United States and Canada, and are continually adding to this list. Relative to the appointment of these attorneys I would say that we require them to furnish three first-class references. Furthermore, I would mention that during the past twelve years your Secretary has transacted business with over 50 per cent. of them, and is well posted as to their capability and standing as first-class lawyers.

FAILURE AND ASSIGNMENT DEPARTMENT.

During the year twenty creditors' meetings have been held.

January 1, 1888, we had in charge 28 failure cases, consisting of 191 claims amounting to..... \$58,417.15

And have received during the year 81 cases, consisting of 474 claims amounting to.... 110,525.50

Making a total of 109 cases; 665 claims, representing an indebtedness of..... 168,942.50

Some of these cases have been settled in the following manner:

21 cases, representing 54 claims, aggregating..... 24,378.26
have been returned to creditors as worthless.

16 claims have been put in judgment, aggregating..... 6,381.53

18 cases, representing 98 claims, or an indebtedness of.....	13,052.83
have been settled through the Board of Trade.	
4 cases, representing 20 claims, or an indebtedness of.....	4,051.22
have been settled in full dividend direct to creditors.	
This makes total actual disbursements in dividends, etc., of.....	17,104.05
To which add collection disbursements, making a total amount dis-	
bursed for the year of.....	42,062.98
Leaving 59 cases, or 477 claims, aggregating.....	121,078.66
open or now on our books.	
3,954 letters have been received, and 7,689 letters have been written during the year.	

As to the work accomplished by this department, I will not encroach upon your valuable time by going into minute detail of the many failure cases that have come into our charge; I will simply cite a few of the largest and most important ones.

1. The B. Franklin & Son failure. By the concerted action and combined efforts of your members individually and your board collectively, two indictments for grand larceny were obtained in this city. On one of these Charles B. Franklin was arrested, brought here and released on bail. A re-trial will take place this month or next. In this trial we learned much by experience. Thus benefitted, we hope that the second trial will secure a verdict in our favor. One of the weak points of the case (His Honor Judge Cowing claimed) was the remoteness of Franklin's statement. Therefore, gentlemen, I take the liberty of suggesting that in all cases where you have business intercourse with the buyer, you should insist upon having a recent written statement of his affairs (either made to yourselves or your Board). The law requires this in criminal suits. With due diligence we feel assured that it will be only a question of time when we shall succeed in landing some dishonest dealer behind the "bars of justice," and thus frustrate the plans of other dealers who may contemplate putting into operation similar schemes. The moral effect would, no doubt, be good, and the pecuniary expenditure eventually (directly or indirectly) a profitable one.

2. The failure of Payne, Steck & Co. has probably been, in effect and magnitude the most severe in the history of the jewelry trade.

A number of our members were largely interested, and through the efforts of your Board William H. Payne (the senior member of the bankrupt firm) was extradited from New Jersey, and three indictments found against him by the Grand Jury of this county. He was released on these indictments by furnishing bail for \$4,000.

He was immediately re-arrested on a number of civil suits, and was released on giving bonds aggregating about \$20,000.

We expect to reach a trial of the criminal charges in the next few days, and I feel confident in saying that our members interested will leave no stone unturned to mete out to this defendant such punishment as the law provides.

3. The J. M. Chandler & Co. case (which doubtless is still fresh in most of all your memories) plainly illustrates what concerted action can accomplish in failure cases, and how utterly impracticable it is for the individual creditor (as a general rule) to act independently with the expectation of realizing a larger dividend on his claim than his neighboring creditors.

In this case Mr. Chandler came east about four months ago and asked an extension (which was not fully granted him), and afterward made an assignment. Meetings of creditors were held by the Manufacturing Jewelers' Board of Trade, of Providence, and your Board, and after appointing their committees they joined hands, and each Board's Cleveland attorneys were directed to act in concert toward the removal of the assignee.

Pending this action offers of compromise were made of 25 per cent. and 33 $\frac{1}{3}$ per cent. but declined, mainly for the reason that the debtor could not satisfactorily explain the cause of the large shrinkage of some of his assets from the time he had been in business up to the date of his failure. After a great deal of trouble and laborious and intricate work performed by the committee of the Manufacturing Jewelers' Board of Trade, of Providence, Messrs. Vose and Barton, and the committee of this Board (Henry Dreyfus, Isidor Stern and George E. Fahys), as well as the able assistance rendered by our Cleveland attorneys, Messrs. Everett, Dellenbaugh and Weed, the assignee was removed and a trustee of our choice, U. R. Sigler, was elected in his stead.

An offer of compromise of 35 per cent. was then made, and afterward raised to 40 per cent., which was accepted, all expenses of suit, court costs, attorneys' fees, etc., being paid by the debtor, thus making a 40 per cent. net settlement to our clients, being actually 10 to 15 per cent more than the creditors who did not join with us in this action received from the estate.

The two Boards in this case represented an indebtedness of \$44,000, or about two-thirds of the debtor's entire liabilities; and their co-operation shows what a power they can be in the trade by working unanimously together for the common welfare of their members' interests whenever the opportunity presents itself.

For the reasons already mentioned I have only cited three of the open failure cases that are not yet fully closed up, but in reference to the balance (fifty-six) would say that they are being carefully looked after, and the parties whose interests we represent arduously guarded and protected to the best of our ability.

Your Board of Directors, in pursuance of a resolution passed at your last annual meeting to appoint a resident attorney, after due deliberation and careful consideration chose from a number of highly recommended applicants G. C. Comstock, who, no doubt, is well known to you all, and we sincerely trust that what business you have found it necessary to intrust to his care has been satisfactorily and ably attended to.

The work accomplished by this office during the past year, as the statistics show, far exceeds that of the previous year, and only by long hours and the faithfulness of our little corps of clerks, which is the same in number as last year, have we succeeded in keeping the work up to the standard. We have earnestly striven to give entire satisfaction, and in this effort hope we have succeeded.

Respectfully submitted,

H. M. CONDIT, *Secretary.*

After the reading of the Treasurer's and Finance Committee's reports the following directors were elected for the coming year: William Bardel, Heller & Bardel; John C. Downing, Downing & Keller; Gurdon W. Hull, Simpson, Hall, Miller & Co.; David Keller, Pforzheimer, Keller & Co.; Max J. Lissauer, Lissauer & Sondheim; S. F. Myers, S. F. Myers & Co.; August Oppenheimer, Oppenheimer Brothers & Veith; Frank H. Richardson, Enos Richardson & Co.; Edmund J. Scofield, Elgin National Watch Company; William Smith, William Smith & Co.; Leopold Stern, Stern Brothers & Co.; J. P. Snow, G. & S. Owen & Co.; S. Aufhauser, Keller & Untermeyer.

From among these the following officers were elected: President, William Smith; First Vice-President, Leopold Stern; Second Vice-President, Gurdon W. Hull; Treasurer, David Keller. A vote of thanks having been passed to the members of the retiring board, N. Kauffmann, of Citroen & Co., arose and submitted the following resolution, which, after a spirited discussion, was unanimously carried:

Whereas, The jewelry trade has for some years past suffered numerous losses, by reason of the unsettled condition of the laws governing pledges of property in the hands of pawnbrokers; and,

Whereas, The laws, as at present interpreted, have worked incalculable injury to trade and to the morals of employees; and,

Whereas, It is the immediate duty of every merchant, to himself and to the public at large, to do his utmost to remove the temptations existing under this order of things, and to influence the passage of an equitable and uniform law on the subject.

NOW THEREFORE BE IT RESOLVED, That the New York Jewelers' Board of Trade appoint a committee of three with power to act as they deem advisable in the premises, and to confer with the New York Jewelers' Association or such committee as may be appointed by said body for that purpose, and that it be recommended to said committees to obtain the co-operation of the trade at large in the passage of such a law as may be suitable.

A resolution providing for the appointment of a committee of five to arrange for the first annual banquet of the Board, which is to take place about the time of the next annual meeting, was unanimously carried.

Sections of Article V. were amended, viz.:—

SEC. 2. To read: "The Secretary may act as assistant Treasurer, and in that event shall be charged with the custody of the funds of the Board of Trade, and shall furnish such bonds as the Board of Directors may require. All disbursements shall be made by him under direction of the Treasurer. All funds received by him shall be deposited in a bank satisfactory to the Board of Directors, and all disbursements and payments shall be made by checks signed by the Secretary and countersigned by the Treasurer, or, in his absence, by the President. He shall keep a book of record of all receipts and disbursements, making a report of same to the Board of Directors at each regular meeting, and to the Board of Trade at its annual meeting."

SEC 3. To read: "The Secretary shall notify each member of the Board of Directors of all meetings, and each member of the Board of Trade of every meeting of the Board of Trade. He shall make and keep a true record of all the meetings of the Board of Directors and of the Board of Trade. He shall issue all authorized notices to members, conduct the correspondence of the Board, and perform such other duties as shall be directed by the Board of Directors. On application of any member of the Board of Trade he shall make inquiry of each and every member concerning the financial standing, credit and character of the party or parties specified by said member making the inquiry. He shall collect all dues and assessments and all other moneys due to the Board, making a monthly report of same to Board of Directors."

The meeting then adjourned.



* A Complete History of Watch and Clock Making in America.

[By CHAS. S. CROSSMAN.]

Number Thirty-One.

Continued from page 35, February, 1889.

WATCH CASE MAKING.

WESTPHALL & SONS.



AS FAR AS it has been possible to ascertain, Charles William Westphall was the earliest casemaker in Philadelphia. His name appears in the directory as far back as 1801, at which time he was located at 72 North 7th street. But little is known of his history other than that, and the establishment was conducted on a very small scale.

They removed to 166 North 4th street, at the corner of Sassafras street, now called Race street, where they carried on a rather miscellaneous business, including watch case manufacture, gold smithing and gun making.

From 1811 to 1820 they removed the business successively to 69 Crown street, 87 North 2d street, 81 New street, 268 North 2d street and 11 York Court, and were in this locality when in the latter year father and sons were all drowned on a 4th of July boating excursion. The widow carried on the business for a short time, but discontinued it.

WILLIAM WARNER,

One of the earliest casemakers of Philadelphia, was born in Baltimore, Md., in 1784. He, together with his brothers, Ellicot and John Warner, carried on a silver smithing business there for some time.

In 1811 Wm. Warner came to Philadelphia to work at his trade, and three years later he decided to begin the manufacture of watch cases. He began operations at 21 Greenleaf Court, but four years later he removed to 7 Cherry street. By the year 1830 his business had increased so that he gave employment to eight hands. He made the first engine turning lathe ever made in America. It was copied from a Swiss lathe. With this machine he was enabled to execute a high class of work, and he attained quite a reputation for chased and engine turned work. He used only 18 karat gold in the manufacture of cases.

His sons, Cuthbert, Charles P. and Ralph, learned the trade with him and worked in his shop. In 1839 he removed to 90 Cherry street and in 1844 to 118 Chestnut street. Here the firm became William Warner & Co., the sons being taken into partnership. They remained at the Chestnut street location four years, and then moved to a shop in Ransted Place. Here business was carried on with success.

In 1849 William, together with his son Ralph, took up the manufacture of gold watch dials, and his sons, C. & C. P. Warner, meanwhile carried on the case business in the same building.

Wm. Warner finally withdrew altogether from the business, leaving it in charge of his sons and son-in-law, Thomas Hellum. The latter was soon after elected Recorder of Deeds and gave up the case business.

Wm. Warner, after his retirement from business, removed to Jenkintown, Pa. He was at one time a large stockholder in the

Girard Bank. He died at Tioga, Pa., in 1869, at the age of eighty-five years.

C. & C. P. WARNER.

The latter were sons of William Warner and succeeded to the case business in 1844 which their father had established in 1814, and carried on in a very small way for many years.

At the time the senior Warner withdrew from the firm they were located in Ransted Place. In 1856 they were burned out. This fire destroyed the engine turning machine which had been constructed by their father, William Warner, during the earlier years of his career, and was at the time considered a model of its kind.

Messrs. C. & C. P. Warner, then located at 22 South 5th street, at the corner of Minor street.

In 1860 they took in as partner Joseph Seydel, who had formerly been in their employ, and more recently had been a member of the firm of Gigon & Seydel. The name of the firm was then C. & C. P. Warner & Co. They made gold cases entirely, principally 18-k., for both Swiss and American movements at this time. About fifteen men were employed, and from thirty to forty cases were turned out per week.

The firm continued in business until the beginning of the war in 1861, and then sold out to Pequignot & Bro., who receive due notice as a firm.

JOHN S. WARNER,

A brother of William Warner, started to make watch cases in 1829 at 134 Market street. The following year he moved to the shop occupied by his brother at 21 Greenleaf Court. He remained in business here until 1837, but was not successful.

In 1840 he formed a partnership with Mr. Keating, under the firm name of Warner & Keating, which lasted about two years.

Mr. Warner afterward accepted a position under the Girard Trust and gave up case manufacture. He served his country in the war of 1812.

DAVID LOUIS HUGUENIN, SUCCEEDED BY SIMON AND PHILIP PAUL.

David Huguenin came to America from Switzerland in 1820, and located in Philadelphia. He brought with him two female employees, a polisher and an engine turner, the latter of whom was married to Simon Paul in 1837.

Mr. Huguenin commenced case making in a shop on Market street between Bank street and Strawberry Alley. He had Celestine Jacot in his employ at this time, and also two brothers named Simon and Philip Paul.

In 1832 Mr. Huguenin returned to Switzerland, leaving the business to his two sons, Jules and Edward Huguenin. They disposed of the business to Simon and Philip Paul the following year.

The Messrs. Paul occupied the same shop that had been used by the Huguenins, and carried on the business for about six years. Philip Paul was given to dissipation, however, and the business gradually fell off. In 1839 they sold out to Celestine Jacot, who will be noticed in another connection.

THOMAS C. GARRETT

Is a son of Philip Garrett who kept a jewelry store in Philadelphia, beginning with the present century, at No. 11 South 4th street. He was, of course, trained at the bench. He finally succeeded to his father's business, and in 1834 began to think of making watch cases, and for this purpose associated with him Eden Haydock, a watch repairer and a good mechanic. They purchased two dwelling houses in Franklin Place near 3d street, and a four story building and added to the rear of one of them for factory purposes. The parts of the buildings not occupied by them were rented to manufacturing jewelers. By 1836 they employed 12 hands, and were considered extensive casemakers for that time. They ran the business until 1844, when they sold it to J. A. Simpson & Bro., who soon after discon-

tinued. Mr. Garrett continued in the retail business, which he had in the meantime retained an interest in, until 1865 when he retired. He is now a resident of the suburb of Germantown, a venerable and respected Quaker citizen.

WILLIAM MCNEIR

Was born in Baltimore, Md., in 1792. He worked there for a time with Ellicott Warner, who was a silversmith. In 1814 he came to Philadelphia, where he served an apprenticeship in the case business with William Warner and afterward worked as journeyman.

In 1834 he commenced business for himself on a small scale, being located in Rose street between Wagner's Alley and Eighth street. He subsequently moved to Second street and La Grange Place. He made some gold cases, but principally gilt cases, called pinchbeck.

After the Mexican War broke out he gave up business and joined the army. He died in 1849 after serving about a year.

CONSTANT GIGON AND SUCCESSORS TO A. HUMBERT.

This business was established in 1837 by Constant Gigon, a native of Switzerland. He commenced business for himself in Pine street near Sixth, in the city of Philadelphia. Previous to this he had been in the employ of Mr. Huguenin.

Mr. Gigon had gotten his business fairly under way by 1840, but died in that year, being accidentally poisoned by eating food which had been prepared with arsenic taken from a small sack supposed to contain flour. He was succeeded in business by his two brothers, Gustave and Zephirin, who had been in his employ. They continued under the firm name of Z. & G. Gigon until 1855, changing their place of business meanwhile to Second and Chestnut streets, and later to Second and Dock streets. In 1855 Zephirin went to Switzerland where he died ten years later.

After his brother's departure for Switzerland, Gustave formed a partnership with Joseph Seydel, which continued until 1859. They then dissolved partnership, and Gustave Gigon formed a partnership with C. and A. Pequignot, under the firm name of Gigon, Pequignot & Bro., the business being carried on at Second and Dock streets. Business was pushed and gold cases were turned out at the rate of 250 per week.

This partnership was dissolved in February, 1863, at which time Messrs. Pequignot withdrew from the firm and removed to 22 South 5th street, and Mr. Gigon took in Gustavus Willimen as partner, he having been in the employ of the former firm. In 1867 this firm of Gigon & Co. was dissolved, Mr. Willimen going to New York. Mr. Gigon then carried on business alone for two years, but in 1869 Alfred Humbert was taken into the business, and in 1873 Antoine Deschamps, the firm name being Gigon & Co.

In 1876 Mr. Gigon died at the age of fifty-five years, and Alfred Humbert succeeded to the business, with Mrs. Charlotte A. Gigon as special partner.

In 1881 Louis Sorlin was admitted as special partner. The same year Mr. Humbert removed the business to No. 925 Chestnut street, where he greatly enlarged the facilities for manufacturing, subsequently joining with Booz & Co. to form the National Watch Case Co., 715-17 Arch st., by whom the business is now carried on.

REESE S. PETERS

Was brought up on a farm in Chester County, Pennsylvania, and came to Philadelphia in 1840, being then a young man. He worked at the carpenter's trade for eleven years, at the end of which time he decided to begin the manufacture of watch cases. For this purpose he associated with him his brother Randolph, who had been working at the tailoring trade. They were enabled to get a start in business through the assistance of the late William Mullin, one of Philadelphia's greatest philanthropists.

They commenced operations at the corner of Dock and Walnut streets in 1851, the firm being R. S. Peters & Bro. Neither of them being practical men at the start, they had to depend on a foreman

entirely to carry on the mechanical part of the business, but they soon became conversant with all its branches.

The firm was R. S. Peters & Bro. for about eighteen months, but in July, 1852, they dissolved partnership, Reese S. Peters starting a new business in Pear street. He remained here but one year, and then moved to the corner of Fifth and Chestnut, on the east side of the former street.

In 1858 he formed a co-partnership with James Boss, the firm occupying Mr. Peter's place at Fifth and Chestnut streets. They manufactured the Boss filled case, which had been invented and patented by Mr. Boss.

In 1860 the partnership was dissolved, Mr. Peters moving to 308 Chestnut street and Mr. Boss to Sixth and Cherry streets.

From 1858 to the expiration of the first patent on the James Boss filled cases in 1875, Mr. Peters was engaged in their manufacture by special arrangement with Mr. Boss. This privilege was not granted Mr. Peters under the renewal of the patent, but upon its expiration in 1882 he again commenced the manufacture of filled cases, which he still continues at the same location.

RANDOLPH PETERS,

Like his brother, Reese S., was brought up as a farmer in Chester County, Pennsylvania, and came to Philadelphia in 1840. He worked at the trade of a tailor until 1851, when he began the manufacture of watch cases at the corner of Dock and Walnut streets in company with Reese S. Peters. They had in their employ James Boss, who afterward invented the famous Boss filled case.

In July, 1852, the brothers dissolved partnership, Randolph continuing the business at the old stand and taking in Mr. Boss as partner. The firm was Randolph Peters & Co. and remained so until 1856, when the partnership was dissolved. Randolph Peters then removed to the corner of Fourth & Arch streets, where at the expiration of one year he failed. He then gave up the case business entirely and went to farming, which occupation he has since followed.

(To be Continued.)

The Marfels Watch Collection.

[From the *Deutsche Uhrmacher-Zeitung*.]

Continued from page 81, February, 1889.

PART IV.

AFTER HAVING, in the preceding numbers, engaged our attention specially with the mechanical portion of the watches, we pass to those pieces distinguished principally by their artistic external adornment, among which, however, we will at the same time meet with many watches with a highly original and ingenious mechanism.

Everything which the decorative arts, at the time of their highest development, were capable of producing of chased and *ciselé* work and of adorning with enamel jewels and gems, we will meet with upon the cases and dials of many pieces of the collection. In comparison to the handsome specimens found here, as far as art and beauty of form are concerned, our present watches, even never so highly engraved and ornamented, nevertheless appear poor and commonplace. The comparison results so much in favor of the earlier masterpieces because they are all the work of hand, whereby each piece has, as it were, its own individual character, which, considered as a whole, makes them far more attractive and imparts to them a far higher artistic value than possessed by the watches of the present era, which are made by the thousand.

From among the many artistically embellished watches, we single out first of all a gold repeating watch, fig. 21, with musical chime

and dancing figures, made toward the end of the last century. Its style of execution is so highly artistic, and everything about the watch so well finished, that it is safe to assert that there is perhaps no second specimen equalling it to be found anywhere. Upon the very finely-painted gold-enameled dial, the picture representing a palace and surrounding country scene, are several very skilfully chased figures: Venus with Cupid and a shepherd who plays upon a lyre. The goddess holds the little cupid by the hand, and dances



FIG. 21.

him upon her foot to the time of the melody played by the chime, while the shepherd permits his hands to glide over the strings exactly in time with the music, varying their positions even according to the notes—now higher, then lower. A very charming effect is produced by the rhythmical motions of the figures, which, as said, all take place exactly in time with the melodies played, so that this watch is pronounced by all visitors to be the best in the collection.

Another highly interesting specimen in the collection is the watch shown in fig. 22, the case of which is entirely of chased iron,



FIG. 22.

perforated with delicate arabesques. The very laborious workmanship shows, in its automatic striking mechanism and bell, and other details, that it was made by a German master. Joh. Butz, of Augsburg, is its maker, to whom its construction must have cost many an hour of labor. According to all appearances, it belongs to the XVIIth century, as it has neither balance spring nor minute hand. The handsomely engraved silver dial alone is of high value as a work of art.

Another substantial specimen of German construction is shown in fig. 23, an antique silver verge watch with pendulum balance, visible through the crescent cut-out in the dial. The work differs from the ordinary verge watches also by having its arrangement for regulating upon the dial, as shown in the cut. The silver dial is a masterwork



FIG. 23.

of engraving. The figures are executed with extraordinary exactness, and around the rim are arabesques, engraved in relief. The carefully worked movement, with delicate, pierced pillars and handsome engraving upon the back plate, corresponds to the artistic exterior. The inscription upon the back plate states that the maker of this excellent piece of work was Joh. Hene, of Würzburg; its year of manufacture may be set down at 1730.

The next following piece, shown in fig. 24, a very valuable gold verge watch, was to all appearance a present of some prince. It was made by Frs. Desquivillon & de Choudens, in Paris, and belongs to the time of Louis XVI. The fairly flat and very delicately worked movement of the watch has a verge escapement, but possesses nothing else remarkable; the case, however, is a veritable *chef d'œuvre*, drawing forth exclamations of admiration from everyone. The back of the case is ornamented with an excellently executed enamel picture, surrounded with delicate miniature wreaths, in the manufacture of which the enamellers of that age were masters. The edge is set with large, valuable pearls, which serve as a frame to the picture, and produce a most charming effect. The bezel also is similarly studded with valuable pearls.

Some of our readers may perhaps smile in derision at the ecstasy produced by a lot of old watches because work just as handsome is



FIG. 24.

made at present. This, however, is an error in many respects; many arts, have been lost if not altogether, at least partly, in the course of time, as, for instance, the art of enameling. Anyone who has ever seen specimens of the art of enameling executed by Petitel—even though it be a simple head—must, when comparing those specimens

with others produced at present, acknowledge without hesitation that this artist stands unexcelled.

This holds equally true in many branches of the art, in which our predecessors still stand as our teachers. We are still mere imitators



FIG. 25.

and pupils of the old Greek sculptors, and follow their masterpieces chiseled out 300 B. C. Therefore, all honor to our predecessors.

In the accompanying specimen, a gold, double case repeating watch in the style of Louis XV. we again meet with one of the most precious and admirable specimens of the collection, of so rich and rare an execution as we have never yet seen. We will endeavor to lay it before our readers, both by illustration and description, although we must state that it is next to impossible for even the best woodcut to do full justice to a masterpiece of this kind, which is executed in the brightest and partly translucent enamels.

The interior, actual case is on the sides surrounded with a perforated ornamental wreath, to permit the sound of the bell to issue more fully. On this perforated ornamented wreath closes at bottom a multi-colored, enamel, fancy embellishment, of a style and manner of ornamentation that nothing more beautiful can be imagined. This case is enclosed in another outer case, of pure gold, shown in fig. 25, which is still more precious than the interior case. In its center is a vase in enamel *en grisaille*, surrounded by several enameled garlands, which again are enveloped by a wreath of diamonds. The execution of the two cases is, down to its minutest details, truly artistic and in the highest style of taste. The enameled ornaments are in true harmony, and are introduced lavishly upon the two cases. Also, the bezel of the covering case is richly set with brilliants, as is



FIG. 26.

to be seen in fig. 26, which shows a front view of the watch. It must also be mentioned as specially remarkable that the bezel at the lower part of the case does not close flat and smooth but in wave lines, which must have made the execution exceedingly difficult. In

spite of this great difficulty the case is worked so exact that the closing can truly be called hermetical.

The extremely carefully-worked movement is very characteristic of the old verge watches of that period (1750). The watch strikes the full hours and the quarters upon the bell situated within the interior case. The dial is enameled white, and, as shown in fig. 26, bears Turkish figures, from which it may be concluded that this precious watch once belonged to a mussulman. The hands are also wrought in the style of Louis XV., and, similar to the case, richly ornamented with brilliants, of which we counted more than 200 on



FIG. 27.

this watch. We may, from all indications, assume that the watch was a present made in the XVIIIth century by a princely person to an Oriental ambassador. It is well known that these dignitaries often received watches, tobatieres, rings, etc. We are led to assume that it was made by L. Perigal, of London, and can hardly have cost less than \$2,500 to \$3,000.

Our attention is next attracted to a so-called pocket traveling



FIG. 28.

watch with automatic striking work, which in all probability belongs to the XVIIth century. The valuable part of this watch is the bronze case, the side view of which we show in fig. 27. This case, similar to several previously shown, is entirely made by hand, hammered out of a flat piece of bronze. Neither a soldering seam, nor a piece united with the case, can be seen at any place, which fact alone will tell the expert what difficulties the artisan must have had in making it. The broad case rim, as shown in the cut, is surrounded by a very handsomely perforated broad ornamental band, which encircles the whole case with delicate convolutions. The pendant is

surmounted by an acanthus leaf, whereby this otherwise very sober part becomes very charming. It may be said that the case of this watch may, as far as beauty, and we are tempted to add, value, is concerned, safely rank with the above described valuable pieces; although the material value of the case only amounts to a few cents. How little of this, however is considered from the point of view of art, is shown by the circumstance that, when about two years ago the well-known Felix's collection in Cologne was sold at auction, there were paid for a small bronze mantel clock of the XVIIth century, made by the celebrated watchmaker, Jeremias Metzger, of Augsburg, more than \$11,000; a proof that the artistic value of an object is often absolutely independent of its material.

In the specimen shown in fig. 28, a silver verge watch with alarm,



FIG. 29.

we meet with a rarely occurring treatment of the case. This is perforated (*repercé*) in rosette shape, such as is frequently met with as motive of the rococo style of metal works of the XVIIIth century. The silver dial is also engraved, and consists of two parts, an exterior and an interior dial, the latter of which may be revolved, so as to set it to the hour at which one wishes to be awakened. The watch is already provided with a minute hand, and its time of manufacture is about 1750. The hands are of steel, worked by hand—watch hands made in factories were not yet known in those days. The maker of this watch is unknown; the plate is engraved with "Fecit in Wienn."

The previously described watches attracted our attention princi-



FIG. 30.

pally by reason of the artistic embellishment of their cases; we drop this distinguishing trait for a time, and take up an old Dutch watch simple externally, but whose interior workmanship would evoke exclamations of admiration from every lover of art. As will be seen from the illustration, fig. 29, showing the backplate, this watch is provided with a so-called pendulum balance, such as we have met several times in our rambles through the collection. The uncommonly large bridge has an oval cut-out, in which is set a crystal, to show the performance of the little pendulum. Our attention, however, is chiefly attracted by the rich, artistically executed en-

graving of the backplate and bridge. The relief engraving of the latter is executed with an astonishing degree of delicacy and sharpness, of which our woodcut gives but a faint conception. The subject represents a woman carrying fruits in a basket, ending in an arabesque ornamentation; it is much plainer in the original than in the cut, and is worthy of being called a masterpiece of the art of



FIG. 31.

engraving. As can be read in the illustration, the watch was made by William Gibs, of Rotterdam.

Another very rare, and as far as regards the case, an excellently well executed specimen of the collection is a verge watch with automatic striking part, made at the beginning of last century. The interior silver case, represented in fig. 30, is entirely perforated, its bottoms as well as sides, with vegetable and animal ornaments, and besides this it bears French and Latin inscriptions, such as "Vigilate et orate" (watch ye and pray), etc. These inscriptions have, unhappily, not become plain in photographing the watch, so that they could not be rendered visible in the woodcut. The covering case, shown in fig. 31, is a so-called piqué case, which expression means those of the old tortoise shell cases with small silver and gold pins upon the back, as well as other ornamentations, which are set in and often form charming designs. We will meet with several other specimens of these cases in the collection, and will in due time lay them before our readers.

The watch movement itself is very high, similar to all the watches of that period; the hour is struck upon a very loud-sounding and harmonious bell. The maker of this watch is unknown, as well as the time when made; according to all appearances, however, it dates to the commencement of the last century.



FIG. 32.



FIG. 33.

The small watch with double case shown in figs. 32 and 33, belongs to modern times, having been made by D. F. Aubert, Geneva; various traits indicate that it was made about the first half of this century. Fig. 32 shows the front and fig. 33 the back of this extraordinarily and richly executed watch. The very heavy gold case is

embellished both in front and back with handsome low relief chasing and silver inlaying. Besides this, it is also inlaid with enamel ornaments, which produce a most charming effect. As shown in fig. 32, the front cover has an enameled plate with picture representing two lovers. This highly valuable case contains a very fine cylinder movement, provided with a delicately executed silver dial.

(To be Continued.)



The following list of patents is compiled from the records of the United States Patent Office, and specially reported to THE JEWELERS' CIRCULAR.

Issue of January 29, 1889.

396,777—STEM WINDING AND SETTING WATCH. OSCAR F. STEDMAN, Ravenna, Ohio. Filed April 12, 1888. Serial No. 270,444. (No model.) There are the endwise moving winding stem, the endwise moving bar, a spring applied directly to the end of the bar for moving both the bar and the yoke, and the pivoted spring actuated yoke carrying the winding and setting wheels, the bar being provided with a projection which extends through an opening in the pillar plate and makes direct contact with the yoke.

396,788—EAR JEWEL. GEORGE W. WASHBURN, West New Brighton, N. Y. Filed July 13, 1888. Serial No. 279,825. (No model.) In combination with the ear wire or the like, there are a hollow fastening nut comprising an internal spring plate in the form of an annular disk having inwardly projecting and rearwardly flexible arms which grasp the wire between their ends, and annular front and back plates united at the perimeter of the nut, with the margin of said spring plate between their margins, said front plate having an abutment for said arms on its inner side, and said back plate forming a flexing space behind the arms.

396,914—STOP WATCH. FRITZ BOVET and ALBIN E. BESSIRE, Bienne, Switzerland, assignors to H. Bovet, same place. Filed July 9, 1888. Serial No. 279,386. (No model.)

396,939—BRACELET. THOMAS KING, Providence, R. I., assignor to himself and William C. Greene & Co., same place. Filed August 29, 1887. Serial No. 248,228. (No model.) This bracelet has tubular arms, the cavity of one of which is sufficiently large to receive the end of the opposite arm, and having one end of the smaller arm pivoted within the cavity of the larger, and the other end of the smaller arm held within the said cavity, and also in locked engagement by means of the spring catch and the internal notch.

18,886—CANE HANDLE. FREDERICK R. KALDENBERG, New York, N. Y. Application filed November 8, 1888. Serial No. 290,333. Term of patent, 7 years.

Issue of February 5, 1889.

397,191—WATCHMAKER'S TOOL. FREDERICK LEACH, New York, N. Y., and VINCENT L. FIGAROTTA Jersey City, N. J. Filed June 2, 1888. Serial No. 275,818. (No model.) In this jeweler's tool there is a screw threaded punch and a screw standing at an angle thereto, adapted to engage and release the threads of the punch at will, in combination with each other and with pivoted levers.

397,313—STEM WINDING AND SETTING WATCH. HIPPOLYTE SCHUTZ, Reconville, Switzerland, assignor to Kuhn & Fieche, same place. Filed June 21, 1888. Serial No. 277,749. (No model.) Patented in France Feb. 10, 1887, No. 187,194; in Belgium Oct. 15, 1887, No. 79,123; and in Germany Jan. 5, 1888, No. 42,809. In combination with the spring barrel and the wheel there are a ring having inclined or ratchet teeth on the inner edge, the stem and pinion having inclined or ratchet teeth at one end gearing with the teeth on the ring and gear teeth on the other end, and the train of gear wheels to the hands.

397,350—BUTTON. DANIEL P. FITZGERALD, Newark, N. J. Filed July 12, 1886. Serial No. 207,759. (No model.) This collar or sleeve button consists of a single piece of metal wire, having the head and an enlargement at the junction of the head and post both made integral with the post and upset from the same wire blank, a socket or cavity in the said head and enlargement to receive a precious stone, and a perforation transversely to the said socket or cavity to admit light underneath the said stone.

397,423—METHOD OF DEMAGNETIZING WATCHES, Etc. JOHN GREAVES, St. Louis, Mo. Filed May 14, 1888. Serial No. 273,765. (No

model.) The improved method of demagnetizing articles herein shown and described, consists in placing the article in the magnetic field and then passing it through the angles of magnetic force to a neutral point.

397,433—EAR RING. LOUIS KRUG, Brooklyn, N. Y. Filed March 18, 1886. Serial No. 195,727. (No model.) In combination with a loop or base and a setting, are interlocking eyes provided with knife edges in contact at right angles, one eye being secured to the loop or base and one to the setting.

397,434—SETTING FOR JEWELRY. LOUIS KRUG, New York, N. Y. Filed May 1, 1886. Serial No. 200,832. (No model.) A suspension device in which the parts capable of relative movement are formed or provided, where they come into contact with knife edges.

Issue of February 12, 1889.

397,505—METHOD OF INSERTING MAINSPRINGS AND REMOVING THE SAME. ERNEST KARTHAUS, Huntsville, Ala. Filed April 25, 1888. Serial No. 271,868. (No model.) This method of inserting mainsprings into the going barrels of watches and other timekeepers consists, first, in placing a non-expandible clasp around the mainspring to be inserted, the interior diameter of said clasp being of corresponding or slightly smaller diameter than the barrel into which the mainspring is to be inserted, and then forcing the mainspring into the barrel and causing the clasp to strike the end of the barrel, whereby the clasp is removed from the mainspring.

397,508—BUTTON. JAMES MCNERNEY, Attleboro, Mass., assignor to Wheaton, Richards & Co., same place. Filed Oct. 15, 1888. Serial No. 288,052. (No model.) The button shank has a narrow portion and lateral arms projecting therefrom at its end, which is turned to one side and offset with relation to the main portion of the shank, and button head consists of a cap or top plate and a bottom plate, having an opening through which the end of the shank passes, and a holding plate inclosed in said button head, having an integral tongue and projections extending from the plane of the plate, said projections co-operating with the arms of the shank, and said projection co-operating with the extremity of the shank.

397,566—TEMPORARY CASE FOR MAINSPRINGS. JACOB W. RIGLANDER, New York, N. Y. Filed August 30, 1888. Serial No. 284,156. (No model.) The case has oppositely arranged slots in its wall and means arranged to slide in said slots for ejecting the spring.

397,663—COMBINED MATCH BOX AND CANE. SIMON B. SIMON, New York, N. Y. Filed February 24, 1888. Serial No. 265,099. (No model.)

397,699—ALLOY. EUGENE H. COWLES and ALFRED H. COWLES, Cleveland, Ohio. Filed July 8, 1885. Serial No. 171,011. (No specimens.) A metallic alloy consisting of a proportion of copper, nickel in about half the proportion of the copper, and a percentage of aluminum.

397,744—OPTICIAN'S MEASURING INSTRUMENT. EMIL B. MEYROWITZ and CHARLES E. DRESSLER, New York, N. Y., said Dressler assignor to said Meyrowitz. Filed March 8, 1888. Serial No. 266,627. (No model.) An apparatus for recording facial measurements from which to make spectacles or eye-glasses, consisting of a box or two part frame, one part provided with a measuring instrument having registering points and the other part provided with a templet counterpart for said registering points and adapted to receive one or more papers or blanks, whereby the measurements are transferred to the paper or blanks when placed in position by the closing of the box or frame.

397,774—LOCKET. GEORGE D. BRIGGS, Providence, R. I. Filed March 22, 1888. Serial No. 268,073. (No model.) There is a locket frame provided with two openings, one opposite the other, a plate having integral tubular bearings, on which are mounted the ratchet disks, part of said disks extending through the openings in the frame, a spring mounted in the boss for engaging the teeth of the ratchet disks, and a plate having the two openings through which the face of the ratchet disks may be seen.

397,790—ELECTRO-MAGNET ATTACHMENT FOR EYE-GLASSES. FREDERICK FEAR, New York, N. Y. Filed May 1, 1888. Serial No. 272,527. (No model.) In combination with the metallic frame of eye-glasses or spectacles are the springy metallic nose guards, having their lower ends secured to and insulated from the frame and their upper ends free therefrom, each spring of said nose guards having an insulated electrical conductor wound thereon and electrically connected therewith, and the metallic plates, one electro-positive to the other and electrically connected to their respective nose guards.

397,833—BRACELET. CALEB K. COLBY, Brooklyn, and WILLIAM COPPERSMITH, New York, assignors to themselves and Arthur Colby, Brooklyn, N. Y. Filed March 1, 1888. Serial No. 265,805. (No model.) A bracelet or the like comprising an open elastic band with overlapped ends, the one end being provided with a loop or keeper, and with one or more shoulders, and the other end provided with a pivotally attached bail, one being threaded through said bail, and the other being threaded through said keeper.

397,850—ALARM CLOCK. ROBERT F. GAYLORD, New York, N. Y.,

assignor to James Gwatkins, same place. Filed April 17, 1883. Serial No. 270,954. (No model.) In an alarm clock there are the time mechanism, the alarm mechanism, and a spring pawl carried upon or attached to the alarm mechanism and arranged to engage an oppositely revolving part of the time train whereby the alarm is alternately arrested and released as it runs down

397,853—WATCH MOVEMENT BOX. CHARLES T. GRAHAM, Philadelphia, Pa., assignor to George W. Plumley, same place. Filed October 15, 1883. Serial No. 288,195. (No model.)

Trade Mark No. 16,256—ORNAMENTAL JEWELRY. MOSBACHER & Co., New York, N. Y. Application filed December 19, 1883. Used since July 1, 1887. "The words 'Bon Marche' and a floral design placed in a circle."

Issue of February 19, 1889.

397,933—POCKETBOOK CLASP. CARL G. PFINGSTEIN, New York, N. Y. Filed December 4, 1883. Serial No. 292,623. (No model.)

398,053—SECURING DIAMONDS IN CUTTING TOOLS. HUGO KELLER, New York, N. Y., assignor to Henry A. Parr, same place. Filed April 26, 1883. Serial No. 271,911. (No model.) This improvement in the art of setting diamonds in cutting tools consists in longitudinally dividing the cutting edge of the tool, forming registering recesses in the contiguous faces of sections, inserting the diamonds in said recesses and brazing the contiguous faces.

398,096—CUFF OR COLLAR BUTTON. GEORGE S. TIFFANY, Tecumseh, Mich. Filed July 30, 1883. Serial No. 231,364. (No model.) The collar or cuff button has its head and shoe each formed with oppositely arranged and registering apertures, and a reciprocable fastening pin is arranged in said apertures, and adapted to lie with its point over the face of the head when thrust to the limit of its forward movement.

398,126—EAR RING. LUTHER F. BROOKS, Boston, Mass. Filed June 21, 1886. Serial No. 205,803. (No model.) There are the loop and drop, and a connection or bearing between them consisting of two opposed pieces of hard metal having their straight horizontal bearing edges arranged transversely to each other.

398,241—MUSICAL BOX. FRIEDRICH E. P. EHRLICH, Gohlis, near Leipsic, Saxony, and GUSTAV A. F. MULLER, Berlin, Germany, assignors to the Fabrik Leipziger Musikwerke, vormals Paul Ehrlich & Co., Gohlis, near Leipsic, Germany. Filed January 17, 1887. Serial No. 224,629. (No model.) Patented in Germany June 16, 1885, No. 33,761; in France July 24 1886, No. 150,198; in England July 23, 1886, No. 9,742; in Belgium September 6, 1886, No. 74,465; and in Italy September 11, 1886, XL. 376.

398,251—WATCH CASE SHAPING MACHINE. HENRI L. HALDY, Waltham, Mass., assignor of one-half to John Stark, same place. Filed November 24, 1883. Serial No. 291,723. (No model.) In a watch case shaping machine, a longitudinally movable head stock having a rotary spindle journaled therein, and the cup-shaped expansive work holder are combined with a longitudinally adjustable shaft, a lever secured to said shaft, and a ring connected to said lever for the purpose of compressing said work holder.

398,264—COMBINED FORK AND SPOON. DAVID P. KISNER, Manly, Iowa. Filed December 3, 1883. Serial No. 292,499. (No model.)

398,277—HANDLE FOR OPERA GLASSES. GABRIEL PLESSY, Paris, France. Filed September 11, 1883. Serial No. 235,140. (No model.) Patented in France August 3, 1883, No. 192,212. This handle for opera glasses, binoculars and other articles or instruments, consists of two parts with a double hinge connecting the two parts, and a sliding piece to extend over and hold the double hinge when in use.

18,929—BROOCH. MEYER BALLIN, Chicago, Ill. Application filed June 23, 1883. Serial No. 273,472. Term of patent, 14 years.

18,932—FLASK. LEROY W. FAIRCHILD, New York, N. Y. Application filed January 21, 1889. Serial No. 297,098. Term of patent, 3½ years.

months by the failure of several large jobbing houses in the west, but I have heard of no one who has as yet been seriously embarrassed by them.

ATTLEBORO.

The question of the removal of the Cheshire Watch Co. from their present quarters to this town is still agitating the minds of the people here, but nothing definite in regard to the ultimate result can be ascertained for the reason that no one knows much about it. L. W. Sweet, the company's agent, was in town a few nights ago and met about 20 of the leading business men to confer further with them. Before the meeting adjourned a committee consisting of J. M. Bates, J. H. Sturdy, E. S. Horton, L. W. Barnes and W. M. Fisher, were selected to go to Cheshire and investigate the matter. The sum that is required to be pledged before the company will come here is \$75,000, and if the concern is solid with the prospect of doing a large business this sum can be raised in a very few minutes. In fact, I hear that \$47,000 has already been pledged. The committee will make their trip next week and the result of their investigation will be awaited with interest.

Mr. Ripley, salesman for Watson & Newell, has recently returned from the west bringing a good supply of orders.

Miss A. F. Meader, who has for the past year or two managed the firm of F. S. Draper & Co., has become a partner in the new firm of A. C. Vose & Co., of Boston.

NORTH ATTLEBORO.

T. J. Linton, the would-be founder of a brass industry in this town, is still here negotiating, with not very flattering success, however.

E. I. Franklin says he is doing a very good business. Business is not booming but is better than usual at this season of the year.

F. M. Mauser & Co. still continue to get out new styles in solid silver novelties. Evidently this firm has some fine talent in its employ.

The F. G. Whitney building, one of the most expensive jewelry shops in town, is soon to be sold at public auction.



[FROM OUR SPECIAL CORRESPONDENT.]

THE MERRITT ANTI-TRUST BILL.—TRADE IN THE WEST, PRESENT AND PROSPECTIVE.—FROM OUR "OBSERVER'S" NOTE BOOK.

CHICAGO, Feb. 20, 1888.

It has remained for a Chicago jeweler to endeavor to fasten the name of "trust" to the "American Watch Manufacturers' Association." F. E. Morse is the name of that jeweler, and his appearance before the House Judiciary Committee in the State House at Springfield, last Thursday, has been the one topic of conversation among our jewelers for the past four or five days.

It is but simple justice to Chicago jobbing jewelers to make the statement through THE CIRCULAR that Mr. Morse is upheld in his action by but few of our reputable houses. The leading jobbers here are in favor of the association's constitution: some of them would prefer some slight modifications being made, but none the less is it esteemed a benefit to the trade and to the public, and in this opinion the large retailers emphatically assented.

Your observer has visited pretty well every prominent jobber, and it can be recorded on the pages of THE JEWELERS' CIRCULAR that Chicago jewelers repudiate the attempts of several of their brethren



[FROM OUR SPECIAL CORRESPONDENT.]

ATTLEBORO, FEB. 18, 1888.

There seems to be little of interest among the jewelers just now. The trade generally is in a prosperous condition and the manufacturers are evidently well satisfied with the outlook. It seems to be generally expected that by March 1st, the influx of orders will diminish somewhat but this is always looked for about this time of the year, and it is no sign of a failing in the present "boom." Some of the firms have lost more or less during the past three

to attach to the association the odium now synonymous with "trusts" and "combines." Mr. Morse, Mr. Eppenstein, Mr. Brethauer, and Glickauf & Newhouse are co-workers in this fight.

In comparing the reports made him by the various wholesalers of jewelry, your observer, after careful computation, estimates Chicago's February trade as being perhaps five per cent. less than for February, 1888. The jobbers, however, agree that this fact should lend no discouragement to those identified with the trade, for it is to be remembered that the retail jeweler is a more conservative and judicious buyer than he was a year or two since. He has learned that smaller stocks and more frequent purchases tend to greater net profits and fewer sleepless nights. He looks over his list of bills, payable oftener, and fewer drafts come back dishonored to his creditors.

Manager Peck, as THE CIRCULAR'S observer voiced the above statement, replied that the Waterbury Clock Co. could emphatically endorse it, and he turned to his account of drafts sent out. It showed page after page of drafts made, and opposite every one, almost without exception, was the word "paid." Very few failures are reported in this section, fewer than ever before, and February, always one of the most trying months in the year, has been remarkable for easy collections.

A prominent jobber said yesterday: "We always instruct our travelers to so arrange their sales that few bills mature in February—the retailer is flush in January, if ever, and this and looking over his stock makes him feel tolerably content; but by February he suffers a reaction from the Christmas activity and the complacent satisfaction of January. He has grown tired of paying out his holiday receipts and feels poor. In March he recovers his equilibrium."

The Gorham Manufacturing Co.'s branch had a visit from Mr. Holbrook, of the New York end, last week. He found orders here exceeding the supply, and says the same state of trade at home prevented the accumulation of any great amount of their wares. Gorham goods were never in so great demand as now. The Chicago warehouses have just been fitted with incandescent electric lights throughout, and a new polishing lathe operated by an electric motor will be in operation next week. Mr. Holbrook returned to New York on Saturday.

The Towle Manufacturing Co. tell the same story. The unique and highly artistic styles of this young concern are gaining for them an enviable reputation in the trade, and their spring novelties are awaited with much interest and will doubtless afford your observer a fertile topic on which to exercise his pen.

Simpson, Hall, Miller & Co., in the same building have enough orders on hand to keep all hands out of mischief, and Manager Burchard is always so busied with affairs connected with their increasing trade, that a newsgatherer feels guilty of imposing on good nature when engaging him in the gossip of the trade.

C. H. Knights has returned from New York and from two more recent flying trips in the country. He says the total of this month's trade (to the 20th) will not vary twenty dollars from that of a year ago now. T. J. Bristol is squandering some of his shekels in Paris, and a considerable share of C. H. Knights & Co.'s mail consists of queries concerning the length of "Tom's" absence. "Tom," as he is known to the trade, is as jovial as he is energetic, and there's no traveler, either for Knights & Co. or any other house, who sells more goods or makes more friends.

All of the travelers have packed their trunks and are scattered over the prairies. Among those of the buyers who have not waited to be called on and who have visited this market recently, are: J. C. Klaholt, Springfield, Ills.; John Steinmetz, Galena, Ills.; Otto Kleinfelter, Maquoketa, Ia.; S. B. Martin, Markato, Minn.; W. S. Still, Minier, Ills.; W. N. Boynton, Manchester, Ia.; F. V. Kent, Grand Forks, Dak.; Julius Cronan, Kewanee, Ills.; Frank Le Bron, Keokuk, Ia.; O. Stortmann, Iowa City, Ia.; N. Egloff, Whitewater, Wis.; G. G.

Case, Jackson, Mich.; J. W. Harris, Morris, Minn.; H. E. Fox, Emporia, Kans.; P. F. Westcott, Hopkinton, Ia.; F. A. Rabe, Freeport, Ills.; S. Sweningsen, Austin, Minn.; Howes & Co., Clinton, Iowa; Edw. Hanneford, Milwaukee, Wis.; Henry Linnig, Peru, Ills.; A. G. Forgman, Hillsboro, Ills.; Max Meyer, Omaha, Neb.; J. F. Ingalls, Waukegan, Ills.; C. F. Eustis, Minneapolis, Minn.; E. Winmer, Indianapolis, Ind.; C. C. Pond, Sycamore, Ills.; I. D. Miller, St. Paul, Minn.; S. T. Marcy, White Pigeon, Mich.

M. V. Elson, the Freeport jeweler, passed through here en route to California on the 18th. He intends an absence of six months.

The Blauer Watch Case Factory is again running full time.

J. M. Parshall, identified with the wholesale department of Giles Bro. & Co. for some years, has given up his position.

Benj. Allen is making a tour of the South.

E. A. Williams, who has been a respected retail jeweler here for twenty-five years, died after a very brief illness on Saturday. He leaves a business worth perhaps \$100,000, which his widow will continue, and \$5,000 life insurance. Mr. Williams had throughout his business career here been located on the southern edge of the business district before the great fire on Adams street, and gradually moving farther south as rentals advanced, until he finally settled down on Cottage Grove avenue near 39th street, which is the city limits.

Mr. McKeon, of the firm of Clarke & Co., St. Joe, Mo., passed through here recently from Pennsylvania where he had buried his father.

C. J. Olin, of Piqua, Ohio, and Secretary of the Jewelers' Association of that State, visited here quite recently.

In our last month's letter the devious methods of Geo. H. Loehr were discussed. This has been followed by his arrest on an affidavit made by Rudolph A. Briedenbach, a New York diamond importer, who alleges that Loehr pawned or otherwise disposed of over \$10,000 worth of jewelry consigned to him. Mr. Briedenbach's loss was \$284, the value of a four karat diamond.

Again have Chicago pawnshops served as the harbor of stolen goods. *The Tribune* jewelry store at South Bend, Ind., was robbed about the first of this month and part of the haul has been found here in pawn.

Two "sell outs" in which Chicago jobbers consider themselves more sold than the stocks they want a dividend from, are occasioning much grumbling in trade circles. Harry Snow reported he had "sold out" on February 10, but Norris, Alister & Co. sent their credit man and a lawyer to Grand Ledge, Mich., the scene of action, and succeeded in convincing Mr. Snow that he had best buy back again, which he did, when his stock was immediately attached for Norris' claim of \$2,300. The Meriden Britannia Co. followed suit with a \$1,250 plaster, and the stock will now be sold again—this time by the sheriff. The other sell out was by Haushalter and Righter, of Admore, Indiana. These men, son and employee, respectively, of the elder Haushalter, bought of him his stock of jewelry last June. Last month they sell it back to him again, immediately after an inventory which they claimed showed they had lost \$7,000 in that six months, Haushalter, Jr., and Righter resuming their former positions as employees, and offering their creditors 35 per cent. In the early part of this month a meeting of these creditors was held here to take measures to fight the "sell out," but some have since settled. Others, however, are still holding out, threatening a more severe mode of attacking the sale.

There has not been, since the Geneva Optical Company opened their stock last summer, a thoroughly complete optical goods stock in Chicago. No stock of compound lenses, for example, and other specialties in this line. This has occasioned a greater patronage for this branch of the Geneva house than they had any anticipations of. The officers of this company state that although they estimated that

the opening of the house here would double their western trade, the sales for the six months just ending have been 60 per cent. ahead of their calculations.

Two attractions now present in Chicago are engaging the attention of both resident and visiting jewelers, "The Fancy Goods Fair" and "The Electrical Congress." The first occupies all the available rooms of the Palmer House, and has brought together all the prominent manufacturers, East and West, of all kinds of fancy wares, art bronzes, etc. The second is particularly interesting to opticians, electricians and those watch dealers now studying the effect of magnetism and electricity on timekeepers. This congress opened yesterday and closes to-morrow night.

Among the articles of incorporation filed with the Secretary of State within the past week were those of the "Fort Dearborn Watch and Clock Co.," and of the "Chicago School of Optics." Of the latter, F. A. Hardy, 46 Madison street, is to be the manager, and he has associated with him two opticians, who are also graduates in medicine. The school is to open May 1 for the teaching of the science of optics, and as Mr. Hardy is favorably known to the trade here, the success of the school is hoped for and seems assured.

The Ansonia Clock Co. will move from their present location on Washington street to Wabash ave near Madison street about April 15, where they will have greater facilities for the continuance of their increasing trade. All the clock companies report a profitable and satisfactory trade. It may be said in closing that the Northwest is doing a better proportionate business than is the South, and that southern credits are receiving more scrutiny here.

The failure is reported of S. Pepperman, Greenville, Miss., and of Samuel Schneider, Centralia, Missouri, in both of which Chicago jobbers are losers.

E. J. Smith, formerly and for many years of the firm of M. S. Smith & Co., Detroit's leading jewelers, has become a stockholder in the corporation of Spaulding & Co., and he sails for Paris March 2 to permanently reside in that city in the interest of Spaulding & Co.'s Paris house. Another very recent acquisition to this, the greatest of Chicago's jewelry establishments, is M. St. Anamant, who has been elected vice-president of the company, and will have the management of the Paris house, assisted by Mr. Smith. The capital stock all fully paid has until now been \$310,000, but the contributions of Messrs. St. Anamant and Smith have increased this paid up capital very considerably. It is well known to the trade that M. St. Anamant has resided in Paris for fifteen years or more, and that during that time American visitors to both his town house and country seat have been royally entertained, and visiting strangers generally have been the recipients of very many generous courtesies at his hands.

The last dividend of 15 per cent. paid in New York yesterday to the unsecured creditors of the bankrupt N. Matson estate, brings up the total of those dividends to the astonishing sum of 90 $\frac{5}{10}$ per cent. None of these creditors ever expected to receive more than fifty per cent., and none of them ever would have received more than fifty per cent. had not the tangled affairs been entrusted to the ripe experience and businesslike sagacity of men like Wm. R. Alling, J. P. Snow, Enos Richardson, D. F. Appleton, J. C. Downing and Edward Forman, who are just now the recipients of many congratulatory letters from those interested. These letters of congratulation should be reversed, for it is the happily disappointed creditors that should be congratulated.

THE CIRCULAR'S OBSERVER.

From the Diary of a Practical Man.

THE MINUTE WHEEL AND ITS STUD.



THE MINUTE wheel, and especially the minute wheel stud or pin, is worthy of some attention. Although Mr. Grossmann says in his treatise on "The Perfect Watch," that the construction of the motion work is, to a certain degree, independent from the proportions of the running works; this remark must be taken with a grain of allowance. . . . The repairer will often find watches in which the minute wheel interferes with different parts of the movement—which might have been avoided by having a smaller motion work; consequently it was too large. The vertical escapements of "auld lang syne" with their fairly large proportions of space, have motion work of the most different sizes, which in the so-called

English verge watches, is frequently larger than necessary. In cylinder watches this space becomes essentially contracted already, and especially is this the case in those movements with oblique, or, so to say, radial bridges. Generally speaking, two kinds of constructions of horizontal or cylinder watches may be distinguished—those in which the bridges are nearly all parallel to each other and those the bridges of which start from a central point. For watches of the latter kind the motion work must not be made too large, and the minute wheel must have a very exact place, because otherwise it comes too near either to the barrel or the sink for the fourth wheel.

The proportions of space in watches do not permit to make a pivot on the minute wheel, similar to that in clocks; and for this reason it must be drilled through and run upon a pin. This pin may either be hammered in or screwed in. The first way is the oldest and still employed in English detached levers; it is better, however, to use a hard steel in place of a brass pin (fig. A).

The screwed in pins are of hard steel and there are two kinds: one is screwed in from the dial side (fig. B), the other from the bridge side (fig. C). The latter kind, fig. C, although employed more rarely, may be called best, because by using a screw driver the part may be fastened more securely. By the minute wheel pin ordinarily used (fig. B), special pliers are employed for screwing in, but these not being always at the command of the repairer, he employs other means, the pin vise, etc., which, however, is apt to raise burr on the pin, which gives rise to pinchings. But it must not be supposed that the manner of placing the pin shown in fig. C is the most modern, because there are instances, although very rare, that such steel screws were employed in old carefully made verge watches.

The style shown in fig. B, as previously mentioned, is open to the objection of being inconvenient for screwing in and working loose, which occurs the more easily when the shoulder is small and the thread short. Fig. D shows a security against this working loose of the pin, which device was copied from a Swiss watch.

In practice it is not rare to find the minute wheel pin of a Swiss watch shaky, because the screw will no longer draw. In such a case it is best to put in a new piece, which is done without much trouble, as these pins can be obtained at a material store. It is possible sometimes to make the old pin fit again by punching the brass in the plate, using either a small screw driver or a half round punch; by striking a fairly strong blow with a hammer upon one of these tools, the screw hole is closed so far that the screw thread will become effective again. It cannot be said that this style of producing results is to be recommended, still, it is sometimes found in good and new

MRS. REIS.—The last deceased Emperor of Germany bestowed an annuity of 1,000 marks on Mrs. Reis, wife of the inventor of the telephone.

Swiss watches. This is especially the case with stem winding watches, in which the minute wheel pin must sit very firmly. By this method of dosing the screw hole (to be done upon the dial side of the plate) the minute wheel pin, and with it the wheel may be brought either a little closer to, or farther away from, the center pinion, which in case it were desirable to alter this depthing a trifle, may be of some advantage.

It is often observed only after the watch has been cleaned that this pin is loose, and for this reason the repairer, when he takes down the minute wheel should notice the state of its pin at once, and not wait until he is through with cleaning and putting together. If the hole in the plate is past good service it must be corrected by tapping,

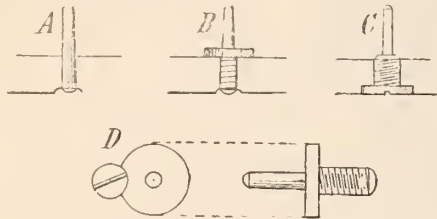

by which operation fine metallic dust may enter into the movement, in spite of all care. The careful workman (even if he be negligent at first) then takes the carefully cleaned and lubricated watch down again, corrects the defect and cleans the plate again, knowing well that no dust will come into the movement. It is, be it reiterated, therefore necessary when taking the watch down for cleaning, to satisfy one's self of the firm location of the pin, because if the repairer does not fasten it, it will sooner or later cause the watch to stand.

While speaking of cleaning, it is worth mentioning that in the brushing of the plate a bristle may easily catch in the screw hole of the pin, and if not thoroughly and effectually removed, the case may occur that the remaining fragment may interfere with the vibrations of the balance by scraping on its rim. Happily this disturbance is easily noticed and quickly corrected.

Washers either laid under or mounted upon the minute wheel pin are occasionally found. This remedy, made use of for raising the depthing of the minute wheel to the plane of the canon pinion, is not permissible, because such a small steel disc is lost only too readily.

The minute wheel pinion may become loose if the hour wheel is too small, in consequence of which the depthing braces and holds the hour wheel; the watch will go badly or stop altogether. By reason of this bad depthing of the hour wheel, the minute wheel pin can also be bent if rather thin.

The minute wheel may scrape against several parts of the watch, to wit, the barrel, the third wheel and the fourth wheel, although these defects are but seldom found, and never all three at once. When the center pinion stands too low, the minute wheel can also easily interfere with the hour wheel, although this occurrence only rarely causes the watch to stand.

Problems in the Detached Lever Escapement.

BY DETENT.



FEW WATCHMAKERS except those who have had long factory experience care particularly to have a job of setting exposed pallet stones. There are many who can do it, and do it well, but still they would just as soon have some other job. Again, there are many others who are very much bothered with a case of this kind. To aid such in setting pallet stones in exposed pallets this article is particularly dedicated. The machine or appliance for this purpose is easily made. Take a disc of thick (No. 14) brass $1\frac{1}{4}$ inches in diameter, and drill a hole in the center about $1\text{-}16$ th of an inch in diameter, around this center hole is sunk a recess $5\text{-}16$ ths of

an inch in diameter and about $1\text{-}32$ d of an inch deep. At fig 1 is shown such a disc, *A* representing the disc, *a* the small hole, and *b* the countersink; we next make two cocks or bridges of brass, using sheet metal about $3\text{-}16$ ths of an inch thick. These bridges are shown at *B B²*, fig. 2, of the correct size and shape. These bridges are screwed to the plate *A*, and secured by steady pins like a watch bridge; one cock is above and one below as shown. One screw will secure both as shown at *d*, fig. 2, and the same steady pin holes will answer by only letting the steady pins go not quite half through the plate *A*. The parts must be carefully fitted so the cocks *B* and *B²* can be taken off and put back without changing their relative positions. Through the ends of these bridges are drilled two holes in exact right line and at right angles to the plate *A*, as shown at the dotted line *i i*, fig. 2; through these holes go two pump centers for holding the ends of the pallet-staff pivots when the pallet stones are set. About the best way to make these bridges is to take a piece of brass large enough to make two and shape it as shown at diagram *B** and drill through (with a sharp twist drill) on the line *c f*, then saw out to the dotted lines, and finally saw apart on the dotted line *A*. The foot or bottom of the bridges *B B²* are filed and fitted so a piece of straight wire will go through the hole in either bridge and strike the hole in the other bridge exactly, as for instance: the wire *c*, when pushed downward will enter the hole in the lower bridge, in fact, as I stated above, be perfectly in line, and the line at right angles to the plate *A*. It is best to drill for the screw *d*, and the steady pins before the bridges are sawn apart. The pump centers *c f*, are merely pieces of Stubs' steel wire with a hollow cone center turned in by putting them in a true split chuck. At about $3\text{-}16$ ths of an inch from the center hole *a*, we drill another hole *h*, about $1\text{-}16$ th in diameter; this hole *h* is to let the guard pin rest in. In the present instance we will suppose we are arranging to set the pallet stones for a Waltham 18-size movement. When we place a staff with its lever and pallets in our machine we clasp the lower bridge *B²* in our bench vise so that the part of the bridge to the right of the dotted line *j* is in the vise; we push the lower center *f*, fig 2, pretty well up and set the top pivot of the staff into the hollow cone in the end of it; then catch the lower pivot of the pallet staff in the hollow cone in the upper center *e* and push *c* down the lower center *f*, going down until the lever rests on the plate *A*, the guard pin of the fork in the hole *h* and the screwheads which hold the lever and pallets together resting in the sink or recess *b* fig 1. We clamp the centers *c f* in place with the two screws *i i*. We now have our fork and pallets placed relative to the plate as shown in fig. 3. To hold the fork in position we make a small slide as shown at *D*, fig. 3. This slide is made up of three pieces, the center one is of steel about $1\text{-}32$ d thick. An end view when seen in the direction of the arrow *K* is shown at diagram *D**. The idea of this slide is, that when the wedge-shaped point of the slide is pressed forward and the set screw *l* secured the lever *E* is prevented from turning. What we need now is something

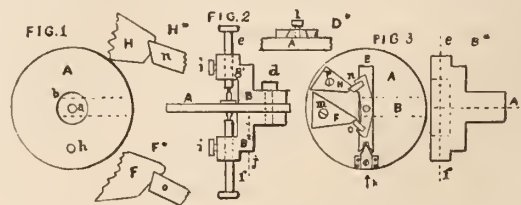

to gauge the pallet stones. I don't mean by this to gauge the thickness, but gauge the position, *i. e.* locate the angle; to do this we place in the machine a correct 18 size (say a P. S. Bartlett) lever and pallets and set up the slide *D*, as shown. We next get out two pieces of sheet brass shaped as shown at *F H* with two small notches at the end to rest against the angle of the pallets *n o*. These notches guide the pallet by resting against the exit angle of the pallets *n o*, as shown enlarged in diagrams *H* F**. The pieces *F H* can be made of hard brass and should be about $1\text{-}16$ th of an inch

thick. After the notches fit the pallet stones nicely we mark where the holes would come for the screw *m p* and drill in the plate *A* to receive the screws and tap out the holes. We next make a couple of large headed screws, and place still larger washers under the heads so that by enlarging the holes in the pieces *F H* we can move them about until the notches in the ends, which receive the angle of the pallet stones, stand exactly right when we set the screws up tight, and drill for two steady pins to each piece. The fork and pallets are now taken out and the steady pins put in so as to restore the pieces *F H* to the proper positions. When we desire to set a new pallet stone we cement it in the pallet, only in placing it we are sure it is in the pallet too far; we now place the pallets and fork in the machine the same as we did in the first instance, and while the machine is in the bench vise heat up the plate *A* until the cement is soft and we can push the pallet stone out until the angle rests in the notch. I know very well all the pallets of any one grade of American watches are not alike, as, for instance, P. S. Bartlett's all vary a little, but pallet stones set in such a device as described come very near and need only slight changes. By making a set of pieces, *F H*, for the leading Elgin, Waltham and Springfield 18 size watches, we can get at almost any job of pallet setting we are called upon to do. We can use the same screws and the same steady pin holes for each set of pieces. The centers *c f* and slide *D* need not be hardened, as they are used comparatively little.



[THE CIRCULAR is not responsible for the opinions or statements of contributors, but is willing to accord space to all who desire to write on subjects of interest to the jewelry trade. All communications must be accompanied by a responsible name as a guarantee of good faith. No attention will be paid to anonymous letters. Correspondence solicited.]

Wilkesbarre, Pa., Jan. 30, 1889.

To the Editor of the Jewelers' Circular:

Enclosed please find blank filled for subscription for coming year, also P. O. money order for same. I have been a subscriber for many years to your valuable paper when in Mexico, and would not be without it now, as it affords me constantly new information. Even the back volumes which I have bound come in very handy to me for the information they contain and I always refer to them with pleasure.

I am even proud to say that I have advanced and learned more since I became a subscriber to THE CIRCULAR than I had learned during my apprenticeship, which I have made in Switzerland, and many times I have made the remark to myself, "Before THE CIRCULAR opened your eyes you were altogether in darkness." The articles which I think gave me the most instruction are "Problems in the Detached Lever Escapement," "Lathes and Lathe Work," "Advise to Watchmakers' Apprentices," also the book "Practical Treatise on the Balance Spring."

I owe a good deal of what I know to THE CIRCULAR, and I would have to be in very bad circumstances to drop my subscription, which circumstance I hope will never come. Without extending myself any further, I remain,

Yours truly, LOUIS BURGER.

Friend, Neb., January 31, 1889.

To the Editor of the Jewelers' Circular:

Yours of January 18 at hand. Am very much disappointed at not being able to procure a copy of "Excelsior's Treatise on the Balance Spring and Compensating Balance." Please inform me if there is later edition on the subject thought to be superior, or are there books pertaining to the same subject by other authors. I need some-

thing of the kind *and must have it*. Please send me sample copy of THE JEWELERS' CIRCULAR for the month of February. Do you know of any good locations for a jewelry store in the East, in New York, Maine or Vermont, or is that out of your line? Intend to subscribe for THE CIRCULAR as soon as located. Hoping to hear from you soon, I am,

Respectfully, F. T. WHITMORE.

Westerly, R. I., January 24, 1889.

To the Editor of the Jewelers' Circular:

Please find enclosed postal note to amount of \$2 in payment of subscription to CIRCULAR for ensuing year, commencing with volume in February. We are always glad to receive THE CIRCULAR, and trust we will grow old together in connection with the trade and be eminently successful. Yours truly,

E. N. DENISON & Co.

Boston, February 4, 1889.

To the Editor of the Jewelers' Circular:

We enclose two dollars for ensuing year, also send a copy Boston Sunday Times which has an article headed "Genuine Curio" that may interest you. If it does please give them credit and send them a copy of your CIRCULAR.

Respy yours,

HARRINGTON & FREEMAN.

Penn Yan, N. Y., Jan. 29, 1889.

To the Editor of the Jewelers' Circular:

Enclosed I hand you P. O. order for \$2 for my subscription to your valuable magazine. Very truly yours,

E. H. HOPKINS.

Eufaula, Ala., January 30, 1889.

To the Editor of the Jewelers' Circular:

Enclosed please find P. O. order for \$2, my subscription for Vol. 20. Please to send me another copy for January, 1889; the one received has a leaf torn, and as I have all the volumes complete, wish them to be perfect ones. I am,

Yours truly,

JAMES MILTON.

Northville, Mich., February 13, 1889.

To the Editor of the Jewelers' Circular:

I will receive bids for all THE CIRCULARS I have—fifteen or sixteen volumes complete.

A. E. ROCKWELL.

LOOKING FOR "THE COMING METAL."

Lancaster, Pa., January 18, 1889.

To the Editor of the Jewelers' Circular:

Can you tell me of whom I may obtain some metallic aluminum or an alloy containing not over 6 or 8 percent. copper. Want to know headquarters and what probable cost per pound would be?

Yours resp'y,

D. F. GROVE.

[We would refer you to Chas. S. Platt, refiner, No. 4 Liberty Place, New York, who keeps a stock of aluminum constantly on hand, and can alloy it if desired.—ED.]

Waverly, N. Y., February, 23, 1889.

To the Editor of the Jewelers' Circular:

I have all the numbers of THE CIRCULAR from December, 1876, to January, 1889, with the possible exception of January, 1877. They are all in perfect order and contain the complete set of monogram plates lately published, besides many valuable articles on watch repairing by Grossman, "Excelsior," and others. If you have any calls from subscribers, or others who desire to get them for binding or to complete articles now running, I would be glad to have you refer them to me, as I would be willing to dispose of them at any price you think they are worth. I shall continue to take them as I

nave for all these years, but having read these ones and not having the time to review them I might as well dispose of them.

Very respectfully yours, WALTER WARE.

A CALL FOR BACK NUMBERS.

Preston, Eng., December 18, 1888.

To the Editor of the Jewelers' Circular:

I am short five numbers of your journal, viz.: October, 1877, January, 1879, February, 1879, August, 1879, and July, 1880, and will gladly pay twice the published price if you can send them. I want to fill up gaps.

Yours resp'y, J. J. BRAMWELL.

[THE CIRCULAR will pay the regular price of 25 cents a number to anyone who can furnish the back numbers above enumerated in good order.—ED.]

BACK NUMBERS FOR SALE.

Minden, La., January 31, 1889.

To the Editor of the Jewelers' Circular:

I have the following back numbers of THE CIRCULAR I wish to sell: 11 numbers of '73, 11 numbers of '74, 12 numbers of '75, 12 numbers of '76, 12 numbers of '77, 12 numbers of '79, 10 numbers of '81, 11 numbers of '82, 4 numbers of '83, 10 numbers of '84, 12 numbers of '85, 12 numbers of '86, 12 numbers of '87, 12 numbers of '88. They are in good condition; will sell one or more numbers, any part or all. Any one wishing them will please write me,

Respectfully, J. R. MILLER

UNSOLICITED TESTIMONIALS.

Buffalo, N. Y., January 28, 1889.

To the Editor of the Jewelers' Circular:

Enclosed find two dollars. I don't wait till 1890, I wish you now a Happy New Year and a prosperous one. You deserve it.

T. V. DICKINSON.

Stoughton, Mass., January 24, 1889.

To the Editor of the Jewelers' Circular:

Have taken THE CIRCULAR for eighteen years. . . .

H. W. DARLING.

C. E. Ryan, Baraboo, Wis., writes: "It is well worth the money."

February 1, 1889.

To the Editor of the Jewelers' Circular:

Enclosed find New York draft for \$2, paying for THE CIRCULAR. I like it first rate.

Yours, H. B. HEALY.

The Jewelers' Security Alliance

President, DAVID C. DODD, JR.

- First Vice-President, AUGUSTUS K. SLOAN.....Of Carter, Sloan & Co.
- Second Vice-President, HENRY HAYES.....Of Wheeler, Parsons & Hayes.
- Third Vice-President, DAVID UNTERMAYER.....Of Keller & Untermeyer.
- Treasurer, W. C. KIMBALL.....Of Strange & Brother.
- Secretary, GEO. H. HODENPYL.....Of Hodenpyl & Sons.

EXECUTIVE COMMITTEE.

- J. B. BOWDEN, Chairman.....Of J. B. Bowden & Co.
- C. G. ALFORD.....Of C. G. Alford & Co.
- N. H. WHITE.....Of N. H. White.
- CHAS. G. LEWIS.....Of Randel, Baremore & Billings.
- F. KROEBER.....Of F. Kroeber Clock Co.
- SILAS STUART.....Of Silas Stuart.

EXAMINING FINANCE COMMITTEE.

- EDWARD SMITH.....Of Smith & Knapp.
- A. JORALEMON.....Of A. Joralemon & Co.

For further information, Application Blanks for Membership, By-Laws, etc., Address P. O. Box 3277. 170 Broadway, New York

At a special meeting of the Executive Committee, held at the Alliance office on January 23, there were present Vice-Presidents

A. K. Sloan and Henry Hayes, Chas. G. Lewis, Treasurer, J. B. Bowden, Chairman, Messrs. Alford, White, Stuart and Secretary Hodenpyl.

The following were admitted to membership: Buchanan Bros., 113 Sycamore street, Petersburg, Va.; John S. Allen & Co., 221 Second avenue, Minneapolis, Minn.; Gaven, Spence & Co., 895 and 897 Broad street, Newark, N. J.

On January 29, H. Silverthorn, Roanoke, Va., First Avenue.

The regular monthly meeting of the Executive Committee was held at the Alliance office on Friday, the 8th inst. There were present President David C. Dodd, Jr., J. B. Bowden, Chairman, Chas. G. Lewis, Treasurer, Messrs. White, Kroeber and Secretary Hodenpyl.

The following were admitted to membership: Gilreath & Patton, 66 Main street, Greenville, S. C.; Dwight Dutcher, 6 Main street, Warwick, N. Y.; William J. Tracy, cor. Main and Chapel streets, Harrisville, Burrilville, R. I.



[FROM OUR SPECIAL CORRESPONDENT.]

ON THE OHIO.

CINCINNATI, Feb. 19, 1889.

February has been a dull month in trade. Just now, however, there appears to be a tendency toward improvement.

It is promised that at least thirty of the retail jewelers of the city will be in attendance on the Ohio Jewelers' Association, which meets in Cleveland in April. The hope is expressed among several of the volunteer delegates that something more definite will be accomplished in the way of pooling interests than was accomplished at the last semi-annual meeting. The local organization started in this city when that meeting took place has not been pushed to that degree of success hoped for it. It appears to have depended for growth upon everybody, and, as the old proverb has it, what is everybody's business is nobody's.

Some time ago Duhme & Co. received a letter from a hayseed up in Ohio offering to sell to that firm a small piece of mother-of-pearl which the owner had inclosed. The owner went on to inform them that the pearl was certainly of great value. He was confident there was profit in it for the firm if they paid him \$1,000 for it. "For," said he, "this is no common pearl, it is mother of pearl, and I offer you the first opportunity to buy it." The letter concluded with advising extra caution to be used in packing if the purchase was not made, and the "mother-of-pearl" was sent back to him. Had the proposed seller said anything about having the father of pearl, a son or a daughter of pearl, a baby of pearl or even a step-mother of pearl the firm might have treated with him. As it was, however, they sent back his pearl, which in reality was not worth the postage they wasted on it.

The Dennison manufacturing headquarters in this city have in their show window a jewel basket made out of more than 38,000 pieces of colored tissue paper. The pieces consist of little tissue paper tubes a third of an inch long, formed by rolling them on an ordinary sized pin. The basket was built up by glueing these tubes together side by side. Their ends constitute the surface, both inside and outside, of the basket. It was made by a German genius at odd intervals.

I talked with a gentleman to-day who, forty-five years ago, began selling jewelry in Cincinnati and who is still engaged in the same business. In a reminiscent mood he said: "Whenever I had any leisure in the early jewelry days it was my duty to spend it in cutting

little bits of cardboard and parchment to be used for tags. Each little bit had to be strung with a thread. Now we buy our tags by the bushel. What cost months of labor then can now be made in a few minutes, while the difference in the cost is still more marked."

During the past month Awalt & Co., Vine street jewelers, were victimized by a confidence woman who secured trinkets of small value, a pennyweighter secured a diamond ring from L. Zuefle, a dealer on Sycamore street, and the jewelry store of Okes, in the Arcade, was entered by burglars, who stole between \$200 and \$300 worth of rings.

Abe Steinau, one of the successful jewelers of the city, was this month appointed a fire commissioner to serve for four years. The position is a responsible one.

While virtue may be its own reward, it is not necessarily the only reward. This was recently shown in an experience had by the house of Duhme & Co. In an attempt to draw a heavily loaded wagon up the Walnut street hill a horse fell when opposite the entrance to the wholesale department of the house named. In falling he got caught in the harness and could not at once regain its feet. While he was struggling and beating his head against the pavement one of the firm directed one of the janitors to bring out some hay and straw that had been used for packing and lay among a lot of other debris. The janitor complied, and the old castaway packing was crowded under the head of the horse as a pseudo pillow, after which the harness was loosened and matters once more set to rights. It was pure sympathy for the horse that had prompted the action. Witness the sequel. But a few minutes after the assistance had been proffered, the owner of the horse entered the store and handed to one of the proprietors a package addressed to the firm, saying, "I guess this belongs to you. I found it in that hay you sent out." On opening the package it was found to contain a detached piece of a valuable bronze which had been reported missing to the original shipper and which had long been given up as hopelessly lost. The kindness tendered proved to be bread cast upon the waters, which returned, not after many days, but in a few minutes.

About two weeks ago Superintendent Detmerring, of the Duerber Watch Case Company in New York, concluded that owing to machinery improvements in the polishing department and the use of several new compounds, the workmen ought to turn out more pieces for a day's work. He accordingly issued orders to this effect. The employees denied their ability to turn out more pieces, and, as a result, the superintendent laid off the entire force of polishers, fifteen in number. The matter is now before the Knights of Labor, of which organization the men are members, and which fact they say is the occasion of the superintendent's discrimination against them.

Luigi Galvani.



THE IMMENSE strides in the progress of arts and science, made within the last century, are due to several causes, principal of which, however, it is but just to state, is the fundamental cause—the great cause, serving as mighty impulse to the marvelous development of human thought; the independence of the United States, and next, the French Revolution, both of which taught the enslaved millions of Europe the lesson that man's inherent right is freedom, to act, to think, to do, to undo, as he lists; that he was not born to be a slave, to act and think at his master's bidding, for his master's glorification, but is by natural laws entitled to do so at his own volition. From these occurrences forward dates the development of man's inventive genius and research.

Four other causes may also be mentioned as having served as the fulcri upon which has rested the lever of our present advancement: The art of printing, the application of steam, the art of galvanism

and the art of horology, as aid in navigation; no other four can, perhaps, in the whole range of human inventions and discoveries be mentioned as having so mightily assisted humanity toward attaining that standpoint of intelligence which it occupies at present. All, or nearly all, others are but the complements—the sequences.

It has been said that the subject of this sketch, Luigi Galvani, discovered the art of galvanism "by accident." Not long ago it was mentioned in these columns that the telescope was discovered "by accident"—a watchmaker's apprentice holds a pair of spectacle glasses between thumb and forefinger, and is astonished at the large size of the point of the neighboring church steeple; a philosopher observes the fall of an apple and discovers the law of gravity; an alchemist, who tries to compose an earthy mixture to make fire-proof crucibles, invents porcelain; Guttenberg, according to tradition, saw the print of a horse's shoe in the dusty road, and gave us the art of printing; the slow oscillation of the chandelier in the Dome of Pisa suggested to Galileo the invention of the pendulum, he discovering the law, Huyghens practically applying it—but why rehearse the chapter of discoveries "by accident," with which everybody is familiar?

Luigi Galvani, whose portrait taken from a painting we reproduce, was born at Bologna, September 9, 1737. At an early age he evinced a strong inclination to devote himself to a monastic life, and his studies in the University of Bologna were, with this view, chiefly



Luigi Galvani.

directed to scholastic philosophy. Swayed, however, by the persuasion of his friends, he relinquished his intention of entering the church and determined to follow the profession of medicine, selecting for special investigation the departments of physiology and comparative anatomy. At this time he enjoyed the benefit of studying under some of the most eminent medical professors of the day—Beccaria, Tacconi and Galeazzi, whose talented daughter he subsequently married. Galvani died December 4, 1798.

The science of galvanism dates just about one century ago, having been made at the close of the 18th century. In the year 1780, Galvani, in making investigations on the nervous irritability of cold-blooded animals, discovered by accident that the limbs of a recently killed frog, when hung by the crural nerve on a metal support near an electric machine, contracted convulsively at the recurrence of each spark. This he properly accounted for. Six years afterward (1786) in experimenting on atmospheric electricity with frog limbs as delicate electroscopes, he obtained, also accidentally, the same convulsions by bringing the copper hook on which the nerve hung, and the limb itself, simultaneously in contact with an iron railing. He continued his experiments, and first published his researches in 1791.

Volta, in 1792, discarded the account given by Galvani of his experiments. In reply to Volta, Galvani proved incontestably that the contraction in the limbs of the frog took place when only one metal was employed, and even when the conductor was not a metal at all. Subsequent discovery has proved Galvani to be partly right in attributing the cause of these convulsions to animal electricity.

Galvani's writings have been chiefly published in the memoirs of the Bologna Institute of Sciences, including the most remarkable production of his pen, the treatise entitled *De Viribus in Moto Musculari Commentarius*.

The Jewelers' and Tradesmen's Company.

GILBERT T. WOGLOM, *President*.

THOMAS A. YOUNG, *1st Vice-Pres.*

EPHRAIM S. JOHNSON, JR., *Sec'y.*

SHUBAEL COTTLE, *2d Vice-Pres.*

SAMUEL W. SAXTON, *Treasurer.*

BOARD OF DIRECTORS.

JAMES A. SMITH,.....M. B. Bryant & Co.

EPHRAIM S. JOHNSON.....Treasurer, E. S. Johnson & Co.

SAMUEL W. SAXTON.....President Solid Link Chain Mfg. Co.

CHARLES A. FOWLER.....Fowler Bros.

JOHN C. DOWNING.....Downing & Keller.

SHUBAEL COTTLE.....President S. Cottle Company.

THOMAS A. YOUNG.....Ex-President National Association of Commercial Travelers ;

Chairm'n Legislative Committee and Vice-President of the Commercial Travelers'

Asso'n, State of N. Y. ; President Traders' and Travelers' Union.

CHARLES F. ROBERTS, M. D., *Medical Director*, 69 E. 54th St., N. Y. City.

SAMUEL A. BALDWIN.....W. E. White & Co.

GILBERT T. WOGLOM.....Gilbert T. Woglom.

WILLIAM B. KERR.....Kerr & Battin.

SAMUEL SONDBHEIM.....D. & M. Bruhl.

Superintendent, BENJAMIN O. LAMPHEAR,

Counsel, JAMES M. HUNT.....(of Rudd & Hunt) 31 & 33 Pine Street.

During the last month the following named have been granted certificates of membership after undergoing the usual careful medical examination: Frederick Leach, with Robbins & Appleton, William Freck, with Henry Ginnel & Co., Richard Bause, with Jewelers' and Tradesmen's Co., John H. Jackson, with Gorham Mfg. Co.; Jacques S. Karelsen, of E. Karelsen's Sons, Joseph Man, with Restfener, Smith & Co., Alfred Barton, Jr., of Ostby & Barton, Theo. G. F. Stumpf, Samuel C. Law, Abram Levy, Thomas W. Landis, Patrick H. Kelly, Albert Janicke, David L. Elder, with L. A. Cuppia, J. Edwin Disbrow, Jas. N. Munson, Benj. J. C. Armstrong, with Spencer Optical Co., Chas. E. Hansen, of Hansen & Tichenor, Frederick C. J. Bause, Emanuel Pelikan and M. Koengsberger, all of New York City; Fred. H. Hazelton and Geo. W. M. Craven, of Brooklyn, N. Y.; Richard Abenheim, of Yokohama, Japan; Julius Hyman, Edward A. L. Golder, with Gaven, Spence & Co., and Francis Holt, of Frank Holt & Co., Newark, N. J.; a total of 27.

Tower Clocks.



AMONG THE several steeple clocks of olden times which have been preserved until the present, is noteworthy the clock at Dijon, France. It belonged originally to the city of Courtray, from which Philipp the Bold took it after the battle of Rosebecq, and had it set up in Dijon in 1382. Upon it stood originally two automata—a man and his wife—called Jaquemart and his wife, who struck the hours. Afterward, in the beginning of the 18th century, a locksmith of Dijon, by the name of Saunois, added a third figure, that of a child, and altered the movement in such a manner that the woman and child struck each the quarters upon a small bell, while the masculine hammered away the hours upon the large. These original Jaquemarts found so much favor that like figures were introduced on most all the public clocks, for two centuries, in Germany, France

and England, and were everywhere called Jaquemarts; still the origin of the name itself is not known. According to some etymologists, the name was said to have been derived from the Latin word *jaccomarchiades*, which means an armor shirt, and was interpreted to mean that these little figures took the place of the watchmen, who in these times used to stand on towers and other elevated places, from which high position they gave notice of important events—conflagrations, the coming of the enemy, etc. Others think that these automata are called for a clockmaker, Jacques Marck, who lived in the 14th century, and is said to have made such figures.

As a consolation to those who complain that tradesmen, even the most skilful, if they are not large manufacturers, earn so little, it may be stated that this complaint is as old as the history of trades itself. For instance, Henri de Vic, who made in the year 1370 the first steeple clock which was set up in Paris, by order of King Charles V., received for it 6 Paris sous, or about 7¼ cents, and a separate room in the tower! Although money had a far greater value in those days, still this stipend was by no means calculated to make him a spendthrift. This clock had a marble plate with the inscription: "This machine, which divides 12 hours with exactitude, teaches you to exercise justice and to obey the laws." This inscription is a direct irony, because this very clock sounded the alarm for the murder of the Huguenots during the St. Bartholomew's Night, August 24 and 25, 1572.

The precious metals gradually grew more plentiful and work commenced to be better paid, as can be seen from a description in the chronicles of the cathedral at Metz, which also had a clock dating to 1391. At that time, perhaps, it was set up within the cathedral. One hundred and twenty years later it was set up in the eastern steeple of the church, where it still stands. Beside the ordinary time it also shows the courses of the sun and moon. It was repaired in 1547 by the steeple clockmaker, Joseph Marit, to whom the city paid 6 livres 10 sous. Another clockmaker, Gabriel Stiches, received 31 livres 10 sous for subsequent repairs. The clockmaker must have thought this sum rather exorbitant, because he writes to the city council when handing in his account, November 18, 1660: "The most learned gentlemen, an it please them, will consider that the said clockmaker spent 5½ days and the largest parts of the nights to set the clock in good order, for which much work and great skill were necessary, and that at this time of winter; and he has been there so successful, that the most learned gentlemen as well as the public will certainly be satisfied and find pleasure in it." One of the successors of the Stiches, a certain Harnax, who was charged with the good preservation of the clock, received free lodging in a house near the steeple; he fastened a rope to the hour bell and from his room could ring it at stated times.

Considering the many wars in which Europe was constantly embroiled for five or six centuries, it is obvious that clocks of a higher class, with automata, were frequently carried off as booty by the victor; thus we find the clock of the Swedish city of Lund in the Province Schonen. This clock, apart from its value as a work of art, also possessed a more tangible value, because all its figures were of silver. When the hour was full two armored knights came out and struck the hour by beating their swords against each other's bucklers. Next opened a door through which Virgin Mary with the Christ child was seen sitting on a throne, with the Three Kings worshipping and offering presents. The door closed again after this, and the same performance was repeated at the next hour. When Schonen was taken possession of by the Danes in 1658, they took the whole clock, with all the figures, on board ship, intending to carry it to Denmark. But the vessel foundered and with it also the clock went to the sea's bottom.

Besides this clock, Sweden possessed still another highly artistic clock, said to have been made by Dasypodius, the builder of the celebrated Strassburg clock. It stood in Upsala, but was unfortunately burned in a large conflagration there in 1702, after it had been repaired by the then very celebrated mechanic, Polhem. The

fact that two clocks of such celebrity were at so early a date constructed in the small country of Sweden, points out that the Swedes find great pleasure in mechanical works of this kind, which is, indeed, the case.

The Opal.

[From *De Diamant.*]



THE OPAL exists in various colors, but there are varieties when cut half round, *en cabochon*, which display a lively play of shades, such as red, green and blue; this sort constitutes the gem opal, which is very valuable, so that stones of a size of five or six lines are frequently paid for with 1,000 florins. This gem opal is found, by only small quantities together, in the so-called trachitis specie of rocks in Hungary, on the southern slopes of the Carpathian Mountains near Gzerwenitza, between Kashan and Eperies. The imperial treasury of Vienna contains the largest and finest specimens of opal known, among others a world-celebrated piece of this mineral weighing $1\frac{1}{8}$ pounds, of the finest play of colors and without the slightest admixture; at the last valuation it was put at a value of 70,000 florins, but others think it worth fully half a million, if not more. This opal, according to some writers, was found by the jeweler Haupt, of Vienna, during the reign of Maria Theresa, who was charged with collecting some flint stones for the mineralogical collection of the capital.

History also mentions another wonderful opal of the size of a hazel nut, which belonged to the Roman citizen, Nanius, in the reign of the Roman Emperor, Marc Anthony. This jewel was estimated at 20,000 sesterils (about 1,400,000 florins), and its possessor was banished from Rome for refusing to sell that gem to the Emperor. He then went to Egypt. In the first half of the last century a gem with a beautiful display of various tints was found by a Christian slave among the ruins of old Alexandria, the French consul, Lironcourt, became possessor of it, and the stone was afterward sold in Europe. Many scientific men hold that this stone might be the celebrated opal of Nanius.

The opals that have not the variegated play of colors are named half-opal, wood-opal (some kind of fossilized wood), meniliet, hydrophane, and another variety named hyalite, frequently occurs as clear as water. Though the opal is hardly transparent and cannot always undergo the process of cutting, neither does it occur crystallized or comes up to the usual hardness of gem stones; it has, nevertheless, in all countries and by all nations been considered of a high value.

The opal seems to concentrate within its substance all the glories of the rainbow, and is considered the finest gems of the mineral world. The Turks believe that it falls from heaven in the lightning flash, and it is often regretted by mineralogists that this theory cannot be sustained. Surely a gem so beautiful, so delicate and so pure ought to be of celestial origin and free from the impurities and imperfections of the earth. We have but one precious stone that comes to us from the far off region of celestial space—olivine—and that, as yet, has been found only in minute grains.

But if we cannot fix the origin of our beautiful gems directly to the stars and other bodies in space, we may affirm that their birth and development in the bosom of our earth may be due, in a great measure, to extra terrestrial influences. And as regards the precious opal, if we cannot prove it of divine origin, we can with truth affirm that there is a deep mystery connected with the mineral, both in its composition and its physical properties.

It has been maintained that the peculiarities of the opal depend, in a great measure, upon the quantity of water it is said to contain, and which, mixed mechanically with the silica, varies from 3 to 20 per cent. Some chemists, however, who have entered exhaustively in the study of the composition of the mineral, do not regard the

presence of water as absolutely essential for the development of the varied flashes of color. We will only state that there is certainly a mystery connected with the part water plays in producing the iridescent.

Certain talismanic powers are ascribed to the opal. Marbodius says that it confers the gift of invisibility upon the possessor, so that a thief wearing this gem might carry off his plunder in open day. The opal is incapable of being engraved as a signet, but cabalistic rings have been preserved where certain signs have been marked upon the opal; and one is mentioned as also having astrological figures carved upon the circle of gold.

The opal is never cut in facets, but always *en cabochon*. The polishing is a work of time and care on account of the soft nature of the stone. So delicately has it to be handled that even the emery powder employed must be *adoucie*, that is, emery which has already been used in polishing other gems and thus deprived of its asperities.

The Different Escapements.



MORE THAN one hundred different escapements have been enumerated by the different horological journals, only a few of which, however, are in use. One noteworthy fact is that the latter were invented by watch-makers who were also good mechanics, and possessed both practical and theoretical knowledge. It is a singular fact that among the many known escapements there are very few simple ones. Complicated movements are patented nearly every month, but new and simple escapements, with hitherto unknown principles, are rare, and it occasionally occurs that the same escapement is invented twice or oftener, because the later "inventor" did not have sufficient knowledge of the labors of his predecessors. Generally speaking, the axiom may be formulated that the number of really simple escapements is very small, and that even these possess few really new fundamental ideas.

Escapements are generally divided into three principal classes:

1. The *recoil* escapements. They are so designated because the escape wheel is carried back during a part of the vibration. To this class belong the verge escapement and a few clock anchor escapements.

2. The *dead beat* escapements. Their name is due to the fact that, excepting the time of impulse, a tooth of the scape wheel rests against the balance axis and consequently does not move. To this class belong the duplex and cylinder escapements, the dead beat escapement of clocks, as well as various others.

3. The *free* or *detached* escapements. In them the balance vibrates free from the influence of the motive power, after it has received its impulse. The lever and chronometer escapements belong to this class.

There is still a fourth class: *Escapements with constant power*, which have been used successfully only in mantle and tower clocks, having given no better results than the ordinary simple escapements in astronomical clocks, watches and marine chronometers.

The recoil escapements are generally regarded as the most imperfect. Concerning the verge, this view is correct, while the recoil anchor escapements for clocks can be constructed in such a manner that the inequalities of the moving power may be compensated within certain limits.

The dead beat escapements give a sufficiently exact result for ordinary use, because the friction against the balance axis can be arranged so that it largely compensates the influence of the inequalities of the motive power, oil and temperature. For this purpose, that part of the axis upon which the friction takes place must be of a certain diameter.

The free escapements, however, are universally considered as the best adapted for watches for scientific purposes, or wherever accuracy

is essential. There are so many varieties of the free escapement that it would be hardly possible to enumerate all the modifications that have been introduced, the details being sufficient to fill a fair sized volume. The English lever is perhaps the best known, and is called a right angled lever escapement. The straight line lever is a variety used in high class watches. These terms are indicative of the relative positions of the centers of the escape wheel, the pallet and the balance. For clocks, however, a dead beat escapement is preferable to a free.

The Ring of the Hohenzollerns.



THE FOLLOWING remarkable occurrence is recorded by the Court Councillor, Mr. Schneider, in the work recently issued by him, "The Life of Emperor William." Schneider was Lecturer to the King, and was one morning of the winter of 1865 in the Adjutant's chamber of the royal palace, when the royal treasurer, Mr. Geisling, who carried a long, doubly-sealed package, entered. The address on the package, written by King Frederic William IV., was in effect: "I have opened this package in the presence of my sister Louise, of the Netherlands, have taken cognizance of its contents, and then sealed it again with my seal, thereupon restoring it for safekeeping to the Prince Wittgenstein." A few days afterward, Schneider found accidentally in the manuscript collection of the Berlin royal library, in an old folio volume, entitled "Alchemy of the old Electors, and various other 'Superstitiosa,'" a notice that King Frederic II., at the commencement of his reign, had, among various other things, also found a little box containing a ring with a black stone, and a slip of paper by King Frederic I. on which was written about the following: "This ring has been given to me by my father, of blessed memory, upon his death bed, with the remark that so long as this ring shall be preserved in the house of Brandenburg, this would not only grow, but increase and thrive visibly." Another notice, referring apparently to the same ring, said* "It is said that a princely person has brought in a large toad and set it upon the head of the princess, who was at that moment in child's labor; this toad vomited forth a golden ring, mounted with 1 diamond and 2 rubies. This ring is still at present transmitted to the first-born of the house to the memory and intended good fortune and preservation of the owner."

Rumor has connected this ring with one said to have been drawn from the dying King Frederic William II.'s finger by the Countess Lichtenau. This says that luck left the Hohenzollerns in 1806, when the Countess possessed herself of the ring; she was treated very harshly and unjustly by Frederic William III., and when finally she returned it in 1813, for a life pension, luck accompanied it. When she took the ring from the dying King's finger, he exclaimed feebly, "*Her den ring*" (return the ring); it was overheard by other persons, and, upon being interrogated, the wily Countess said the King had expressed a desire for *herring*.

Mr. Schneider once read all the notices and paragraphs to the then King William, who answered, "Everything you have read to me concerning the ring and the opening of the package by me is perfectly correct. It is customary in my royal house that the ring together with all the papers are laid before the new King. As far as I remember, it is an old-fashioned ring with a simple, dark-colored stone, the color of which I cannot at present describe. But, at any rate, it is neither a diamond with two rubies nor a black stone. The traditional notices you have read are unknown to me."

Emperor William was thoroughly free from mysticism, yet, from

* The accompanying notice is expressed in the old German of the 15th century, and therefore untranslatable.

his manner of talking on this subject, he appeared as if he placed implicit faith in the power of the ring, credited to it by the accompanying notices and remarks by his ancestors.

Scapewheels of Swiss Watches.



IN THE case of a very bad wheel it would be much easier to change, than to attempt to correct it; there is such facility now for doing this—wheels of very good quality can be got for such a low price, and in such a variety of sizes and heights, that it is rarely a difficult matter to get one of a correct size. If the country watchmaker has no large stock on hand, and must send for a new wheel, it is always best to turn a sink in a piece of brass in the mandrel, as a gauge for size; and if the wheel is not sent, a notch cut for the height also. The removal of the wheel from the pinion should be done on a pinion-riveting stake, in a hole that just fits the pinion loosely; a pointed hollow punch, preferably of brass, fitting freely over the pivot, or in the hollow of the rivets, should be used and a light hammer. The size of the hole in the wheel is the next consideration; it will most probably be considerably smaller than the old. The common way of opening this hole is to brooch it, and as the wheel is generally too hard to brooch as obtained from the material dealer, it is usually put on a wire, and the wire in the flame of a lamp, until sufficiently softened.

This is rather a risky way of doing; the wheel is liable to be got out of flat, or broken in the operation; a far safer and better plan is to grind out the hole without softening the boss. A long and soft arbor is filed lengthways; it should not be too taper, and used with either fine emory or oil-stone dust, the wheel having previously been cemented by its back to either an old fourth wheel or some light, circular piece of brass, to protect the teeth and handle it by. Particular care should be taken not to run the arbor dry while grinding, but to keep it liberally supplied with oil, so that it does not stick. Should the boss be too thick, leaving insufficient rivet, it can be turned down with a hard graver. To turn down the seat, if the watch is flat, would be rather a difficult matter; but if it is at all high, it can be done, supposing that the slot in the cylinder will admit of it. The hole having been ground out until it fits firmly on to the pinion, it should be riveted lightly with a hollow steel punch, revolving the wheel a little between each blow of the hammer, which should be very light. Its truth in flat should be examined from time to time by means of the brass calipers and straight-edge; if the riveting is carefully done the wheel will be true. It will rarely be necessary to bump the arms of the wheel if carefully riveted. The size of the punch should be such that it just goes easily over the shoulder of the pinion, and its face should be perfectly polished.

CHIMES.—Mr. J. H. Addicks, of Amsterdam, Holland, is setting up a chime of bells in a church in Stockholm, to be played in January next. The pin roller is connected with the steeple clock, and has beside this a key board and pedal, by means of which the 35 bells of the chime can be played like an organ. A first trial with only 24 bells, made only a short time ago, was very satisfactory. The clock work will play alternately, every half hour, Martin Luther's "A Fortress Firm is our God," and the doxology. The chime embraces $3\frac{1}{2}$ octaves, and is a present to the city by a merchant and his wife, Mr. and Mrs. W. H. Kempe. The bells weigh 5,986 kilograms, and together with mechanism, freight, erection, etc., the chime will cost 37,000 kronen (1,000 kronen = \$268).



[FROM OUR SPECIAL CORRESPONDENT.]

BOGUS WATCH ADVERTISING.—A CALL FOR JOBBERS.

ATLANTA, February 20, 1889.

This is indeed an age of spurious advertising. When one looks at a newspaper or periodical nowadays he can see where watches—"fine gold ones," too—are advertised to be given away. These advertisements, for the most part, are traps for the ignorant. Only in the last few years has this gift business reached such stupendous proportions, and it looks now as if it had swept the country. These frauds—for that is the right name for them—have had a perceptible effect on the regular and legitimate sale of goods of this character. I do not know that it has hurt one part of the country more than another, but those who concoct these plans seem to advertise most extensively wherever there is a great degree of ignorance. Therefore the South has had her share of these advertisements and has suffered accordingly.

Newspapers generally are so anxious for business that they will accept nearly any kind of an advertisement, whether it is legitimate or not. There are a few papers, however, that have the manliness to refuse all advertisements of an improper character. They should be commended and patronized. This character of work is carried on in the North and West. I do not believe there is a single firm running this "cheap jobbing" business in the South. That much must be said to its credit.

Trade for the past month has been only moderate. A good deal of the heavier goods in the jewelry line have been sold at close margins. As is well known, there are only few wholesale jewelry establishments in the South. The South is behind in this particular, and it is a wonder to me why large houses are not established, especially in our coast cities. The expressage on goods from the East to this place is double what it ought to be, and if goods could be gotten here in larger quantities the amount saved in freight would be a good per cent. itself. This matter is worth looking into by some enterprising man.

J. P. Stevens & Bro. have gone into the watch club business, and have opened up at Rome, Georgia. The senior member of this firm will make things hum, for he is a fine business man, with energy and plenty of capital.

J. R. Watts & Co. have just rented one of the prettiest storerooms on Whitehall street and will move into it in a few days. This is a new firm. It stands near the head for quality of goods.

L. Snider has consolidated his two stores, having moved the one on Whitehall to 10 Marietta street. He is constantly increasing his stock.

T. J. K.

THE MISTAKE MEN MAKE.—The great mistake men make is this: They strive to increase their earnings, but they do not try to increase their earning capacity. They complain of the selfishness of employers when, if they were wise, they would see that in this selfishness lies their greatest opportunity. The selfish employer is always on the lookout for the man that will serve him best and bring the most money into his treasury. He lies awake at night wondering where he can secure such a man. He is willing to reward capacity and fidelity liberally, not because he is generous, but because it is his interest to secure better service and better returns. Many of our young men have been quick to understand the situation, and they have risen in the world.—*Atlanta Constitution.*



NOTHING NEW UNDER THE SUN—As is known to the readers of THE CIRCULAR, dudes of the last century used to wear two watches—a custom which was also adopted by the ladies. Real watches being very costly in that age, however, one of the watches was generally replaced by a "sham watch," or also called "dummy watches," of gold or silver, and according to the estate of the wearer, ornamented with jewels and enameled backs. Some of them had a dial, others did duty as pin cushion. More modest ones were simply made of gilt metal, or overlaid with foil. The wit of the age was directed against this custom, and we reproduce a rhyme clipped from a supplement of the *Universal Magazine* for the year 1777.

"Two tuns of pride and impudence,
One scruple next of modesty and sense,
Two grains of truth, of falsehood and deceit,
And insincerity an hundred weight.
Infuse into the skull, of flashy wit
And empty nonsense, quantum sufficit.
To make the composition quite complete,
Throw in the appearance of a grand estate,
A lofty cane, a sword with silver hilt,
A ring, two watches and a snuff-box gilt,
A gay effeminate embroider'd vest,
With suitable attire. Probatum est"

THE WORKS OF GALILEO.—The King of Italy has appointed Dr. Antonio Favaro, professor of the Royal University of Padua, to collect, edit and publish the works of Galileo at the expense of the State. This gentleman has recently directed a circular to all the collectors of autographs, rare books and manuscripts, and librarians everywhere to assist him in the undertaking of this difficult work, and to send him copies or notices, etc., of everything of interest bearing on this subject.

BAD FOR GERMAN INVENTORS.—The patent law of Switzerland, which entered into force October 1 last, says that all patents of every State belonging to the International Patent Union shall be respected as such, even if they were known and used in Switzerland six or seven months prior to October 1. This excludes German inventors, as Germany does not belong to the union; it has at present about 2,000 valuable inventions, which thus remain unprotected and at the mercy of the pirates.

FRENCH MATCH BOXES.—Match boxes with a little watch set in the front are among the myriad extravagances which tempt the shopper in Paris. A fashionable woman's dressing table and mantelpiece seem fairly alive with tickers in these days, but no great improvement in punctuality has yet been reported.

LABOR OF A WATCH.—A German paper says that no such demands as those expected of a watch are made of any other piece of machinery, and in this regard it stands unrivaled. The balance of the modern watch makes 5 vibrations per second, which is equal to the enormous sum of 157,680,000 vibrations per year. The diameter of a balance of a gentleman's watch averages 18 millimeters, its circumference 56.52 mm. Taking for every vibration one revolution of the balance, then, it accomplishes a distance of 56.52 mm. during one vibration. By supposing this distance to be a straight line in place of a vibratory, the balance would in one second accomplish a distance of 282.6 mm., in one minute 16,956 meters [55,770 feet], in one hour 1 kilometers, 17.36 meters [1 kilometer=1,093,633 yards], in one day 24 kilometers, 416.64 meters, and in one year 8,912 kilometers, 73 60 meters. As is well known good watches make 1½ vibrations, so that the distance accomplished would amount to one-half more than the sum stated. Considering that the pivots are only 0.1 millimeter thick, and that the watch goes uninterrupted for years with almost absolute exactness, an idea can be formed of the demands made of this minute piece of machinery.

WORKSHOP NOTES



EASILY FLOWING SILVER SOLDER.—The following ingredients make an easily flowing silver solder: 2 dwts. coin silver; 1 dwt. brass; 3 grains zinc.

TO BLEACH IVORY.—Ivory that has become yellow by age may easily be bleached in the following manner: The article is placed under a glass bell, together with a small quantity of chloride of lime and muriatic acid, whereby chlorine is developed and exposed to sunlight. Be very careful not to breathe the vapors, it being very poisonous. The bleaching power of the chlorine destroys the yellow pigment upon the surface of the ivory and turns it white.

AN EMERY FILE.—An ingenious device for stretching emery cloth for use in the workshop, consists of a couple of strips of wood about fourteen inches long, hinged longitudinally, and of round, half-round, triangular or any other shape in cross section. On the inside faces of the wood strips are pointed studs, taking into holes on the opposite sides. The strip of emery cloth is laid on to one set in the studs and the "file," as it is called, closed, which fixes the strips on one side. It is then similarly fixed on the other side, and thus constitutes what is called an "emery file," and which is a handy and convenient arrangement for workshop use.

TO HARDEN STEEL.—It is well known that glass acquires a remarkable toughness by being annealed in oil, and that a high degree of hardness is conferred upon metal by a similar process. It is said that engravers and watchmakers of Germany harden their tools in sealing wax. The tool is heated to whiteness and plunged into the wax, withdrawn after an instant and plunged in again, the process being repeated until the steel is too cold to enter the wax. The steel is said to become after this process almost as hard as the diamond, and when touched with a little oil of turpentine the tools are excellent for engraving, and also for piercing the hardest metal.

ACID-PROOF CEMENT.—Make a concentrated solution of silicate of soda (water glass) and form a paste with powdered glass. This simple mixture is said to be invaluable in the operation of the laboratory, where a luting is required to resist the action of acid fumes.

ANNEALING A SPRING.—The temper may be drawn from a spring by laying it flat between two plates fastened together by a screw through the center, and placed upon the annealing plate. A small piece of whitened steel is laid upon it to enable the operator to judge of the degree of heat. Let it cool before opening. When drawing the temper spread the coils.

HOW TO MAKE A GOOD POISING TOOL.—A very useful poising tool may be made by adapting to one end of the ordinary depthing tool two new centers of steel wires. About one half inch of the inner end of each wheel is filed away somewhat beyond the diametrical line. Harden and polish these ends, and they will present, when properly fastened in the tool by the screws, a very nice sharp angle on which to poise the balance. The adjustment for the length of staff is, of course, made by the screws which opens the tool. Removing the roller from the main wheel's arbor in cases where it screws on is sometimes troublesome, unless some convenient tool is at hand to do it with. Such a tool may be made in a few moments by taking a pair of old (or new) round-nose pliers, and grinding or filing the points to a size and shape that will take into the holes usually made in the roller for the convenience of unscrewing it; the pliers can be opened to any distance and consequently will file all sizes. Place the winding square firmly in a bench key held in the left hand, then apply the points of the round pliers in the holes in the roller, and by a firm, steady pressure it will be easily unscrewed with no danger of damage to any part.

EXAMINATION OF WATCH.—When the repairer is examining an anchor watch, let him carefully observe the wheel and action of the pallets; he must ascertain whether the wheel is perfectly true in its division and concentric; any want of accuracy in these points diminishes the soundness of action and impairs mechanical effects, because the amount of drop and locking sufficient for a true and correct wheel would not offer the necessary safety of action with an untrue wheel.

ACTION OF WHEEL AND PALLET.—Try the action of wheel and pallet to ascertain that the latter is properly pitched. This is often not the case, and if it is pitched too deeply the effect will be an increase of the locking arc, consequently an increase to the unlocking resistance, and to the arc of vibration required for the unlocking. Again, the drop will not be equally divided; too little will occur outside and too much inside the pallet, whereby the action is rendered unsafe. For this reason a defect of this kind cannot be remedied by exchanging the scape wheel for a smaller one; it would only correct the first defect without correcting the inequality of the drop.

THE COMPENSATED BALANCE.—As is well known, the linear extension of all balance springs is the same by increasing heat, but the diminishing of elasticity is disproportionate and corresponds to the degree of hardness of the spring. This fact may explain the variation of watches which have been regulated in temperate climates, when exposed to the extremes of the torrid or frigid. A well-hardened balance spring retains its elasticity best, and in some temperatures insures the best rate; not so, however, in extreme ones, since it is subjected to a greater change. The general compensated balance wheel is unable to remedy this defect; it is apt to increase it, because its compensating arms do not, by increasing heat, move toward the center but toward the sides. Ingenuity has been for a long time at work to overcome this evil, and has devised many contrivances, of which the auxiliary compensations by springs, dating to 1835, and recently added compensating arms, need only to be mentioned. Both contrivances, however, do not work to satisfaction, and have not been adopted in practice.

COPYING PRINTED MATTER.—Printed matter may be copied on any paper of an absolvent nature, by damping the surface with a weak solution of acetate of iron and pressing in an ordinary copying press. Old writing may also be copied on unsized paper, if wet with a weak solution of sulphate of iron mixed with a simple solution of sugar syrup.

BALANCE SPRING.—The balance spring is best placed upon a piece of glass, not too thick, which lies upon a piece of white paper, whereby the disturbing shadow is prevented altogether. Much twisting of the spring is injurious to it, as it is very difficult to time a watch with a beat spring.

FORK AND ROLLER ACTION.—In the first place examine whether the first is solidly joined to the pallet (in those escapements in which fork and pallet are two separate pieces). Any shake between these two parts, arising from the pallet arbor or the steady pin not fitting tightly into the holes of either of the two parts, would occasion an unsteadiness of motion and loss of power. Such a defect is not easy to discover in a complicated watch, although very easy to correct. One of the most important points is to examine whether the angles of motion produced by both the wheel and the pallet action, and the fork and roller action are exactly suitable to each other. The lifting at the roller is simply dependent on the respective lengths of the two levers or radii, if the angle of the pallet motion is given. But when the lever and roller are ready made, the angle of their lifting is in a certain proportion to the angle of the pallet motion, and the balance must be pitched exactly so as to produce the angle of lifting for which the proportions of the lever and roller are calculated. For instance, if the balance is pitched at a distance from the pallet greater than it should be, a part of the impulse given by the lever is lost in useless drop.



TRADE GOSSIP.

—The following named jewelers were seen in town during the month: J. Rosenstock, J. S. Hopkins, A. Kummer, Baltimore, Md.; D. P. Cook, B. J. Mandelbaum, Hartford, Conn.; C. Wilson, New Haven, Conn.; F. L. Hughes, H. Leiter, L. E. Kirstein, Rochester, N. Y.; J. Callahan, A. La France, Elmira, N. Y.; A. Eaves, W. T. Liffiton, H. A. Nelson, Montreal, Quebec; L. Marks, John Hoffman, Scranton, Pa.; M. Cohen, Washington, D. C.; E. Zahn, Lancaster, Pa.; O. H. Unger, Reading, Pa.; H. C. Stayner, Milwaukee, Wis.; T. E. Thompson, Galveston, Texas; O. H. Perkins, Des Moines, Ia.; J. F. Steiner, Dubuque, Ia.; C. L. Byrd, Memphis, Tenn.; A. Bigelow, A. W. Briggs, G. F. Blake, D. A. Emery, G. W. Stratton, C. X. Dalton, J. A. Remick, G. W. Kimball, G. H. Richards, Jr., Boston, Mass.; J. G. Ellis, J. C. Lansing, W. M. Whitney, Albany, N. Y.; H. Coburn, Lowell, Mass.; C. D. Hosley, J. D. Gill, Springfield, Mass.; S. Frenkel, J. T. Ellis, C. Allen, W. H. Smith, J. D. Ivey, Toronto, Ontario; J. Wiesbauer, C. Miller, I. Weil, C. F. Adams, E. A. Gillett, Buffalo, N. Y.; B. A. Bell, Chattanooga, Tenn.; J. Bullard, Middletown, Conn.; J. E. Bolles, J. R. Burt, Detroit, Mich.; J. Noterman, J. W. McFadden, C. H. Duhme, Cincinnati, O.; J. P. Stevens, H. L. Rosenfeld, Atlanta, Ga.; A. Weinberg, W. Harris, H. D. Morse, Chicago, Ills.; J. W. Stern, M. Schussler, San Francisco, Cal.; F. A. Steer, L. Lipman, St. Louis, Mo.; I. J. Liberman, Syracuse, N. Y.; T. B. Myers, St. Paul, Minn.; J. H. Leyson, Butte City, Mont.; C. Jarecki, Erie, Pa.; F. A. Knowlton, Worcester, Mass.

—F. H. House is opening a new store in Galva, Ills.

—Isidore Schroeder has been admitted a partner in the firm of D. Schroeder & Co., Cincinnati, O.

—James Fricker, of Americus, Ga., has been elected a director of the S. A. & M. R. R. Co.

—Matthias Huffman, Quincy, Ill., has incorporated his business as the M. Huffman Jewelry Co., capital stock, \$25,000.

—Bhaer & Holzheimer will open a new store in Omaha March 1. Mr. Holzheimer has been purchasing stock in New York.

—Cattelle & Decker are in the field with a large number of sterling novelties. As Mr. Cattelle remarks: "When we say 'sterling' silver it is sterling every time."

—Philadelphia Jewelers are agitating the question of early closing every Thursday evening, except in the month of December. They have every prospect of success.

—Krugler, Kimball & Co., 14 John street, have engaged F. J. Burke, formerly with H. O. Hurlburt & Sons, Philadelphia, to represent them in Pennsylvania, Ohio and West Virginia.

—R. H. Kuhns & Co. will open their new store in Quincy, Ills., soon after March 1. The "Co." is a Mr. Dickey, reputed to be quite well to do; he is a distiller. Mr. Kuhns has been in the trade at Quincy for some years.

—A. K. Sloan, of Carter, Sloan & Co., accompanied by his wife and daughter, and George H. Richardson and wife (J. W. Richardson & Co.), started for the island of Jamaica Saturday, February 23, to be absent four or five weeks.

—Oppenheimer Bros. & Veith have had such a large demand for diamonds that Henry Oppenheimer has already started for Europe to replenish their large stock. The first consignment of this season's purchases will shortly reach this side of the Atlantic.

—Narcisse Turcot, one of the oldest jewelers in Quebec, died recently after a long siege of paralysis. He clung to his business during all his illness. He leaves a widow well provided for, he having amassed considerable property in his long lifetime.

—We have received from W. F. A. Woodcock proprietor of the watchmakers' school at Winona, Minn., a number of endorsements from pupils who have enjoyed the advantages of his instruction, from which we infer that he is meeting with the success he deserves.

—August Morck, Jr., of the firm of Morck Bros., Warren, Pa., was triumphantly elected Burgess of his town on the Democratic ticket at the recent election. The Warren *Mirror* heads the account of the victory—"An August Shower; the New Burgess and his Rain of Votes."

—Henry Oehl, expert watchmaker, who after an absence of six years, during which he has been in the service of several of the newer watch companies, has returned to the Lane and taken an office at No. 17, where he will make a specialty of fine repairing and adjusting for the trade.

—F. M. Whiting & Co., silversmiths, are about to put a new pattern, the "Oxalis," on the market, and that it will be something fine the previous record of this house leaves no shadow of doubt. They continue to maintain their reputation in the novelty branch of their business and always have something new to show.

—The New York Standard Watch Co. will occupy or before May 1 the store at 13 John street, in the new Corbin Building, on Broadway and John street. Their new seven jewel movement is giving the factory of their company all it can do, and large orders are perforce unexecuted. Jobbers not members of the association have large orders already booked. Of all the practical watchmakers who have examined the new movement, none have anything to say except in terms of the highest praise.

—Le Roy Decker, Marysville, O., has purchased the entire stock of Gilbert E. Farrell, of the same town. He will consolidate the two stores, and move into the new Whitney block the 1st of March, where he will have one of the finest stores in central Ohio. Mr. Farrell will remain as an assistant in the business.

—D. L. Brush, who has been for some time with the Ladd Watch Case Company, has been admitted as a partner of the firm of Knoeller & Schuetz, 161 Nassau street, and they will now do business under the name of Knoeller, Schuetz & Brush. They will continue the manufacture of fine jewelry and diamond mountings.

—The firm of L. A. Cuppia have removed to No. 42 East 14th street, where they have fitted up a handsome factory and office on the top floor, accessible by elevator. They have put in the newest improved machinery, and are now in a position to satisfy all possible demands of their customers in the line of novelties in silver and applied gold work.

—Jacob Bennett & Son have moved from No. 925 Chestnut street to No. 1,040, over Blank's confectionery store, where they have fitted up a shop with every improvement and convenience. The long record of sixty years which this house can boast is sufficient evidence of the quality and desirability of their goods. They will now have every facility for meeting the demands of their increasing business.

—Another salesman has been added to S. F. Myers & Co.'s traveling force in the person of H. C. Bucklin, who for the past seven years has been on the road in the interest of J. T. Scott & Co. He is one of the most urbane and popular salesmen of the day, and Myers & Co. are to be congratulated on the acquisition. He will make his initial trip early in March with a brand new line of "everything that appertains to the trade."

—Max Freund, of Max Freund & Co., 8 Maiden Lane, has just returned from a nine weeks' sojourn in Europe, during which he visited the diamond marts in the interest of this growing branch of the firm's business. The firm will import this season more largely than ever before, and the diamond department being under the supervision of so competent a man as Albert Crouze, formerly of Saunders, Ives & Co., they will be fully prepared to satisfy all possible demands of the trade in this line.

—Downing, Keller & Co., manufacturers of fine diamond, onyx and pearl jewelry, 8 Maiden Lane, are repairing the damage to their factory caused by the recent fire at No. 52 Maiden Lane, and expect to occupy their old quarters again before the 1st of April. In the meantime they have secured temporary bench room to fill all pressing orders, though they will not be able to make up much stock this month. When their factory is thoroughly refitted, however, they will have facilities for increasing their production, and with the recent admission of F. A. Frey and C. E. Mott into partnership, Downing, Keller & Co. will more than maintain their well earned reputation for artistic and honest goods.

—At the annual meeting of the stockholders of the Hampden Watch Co., held recently at Springfield, Mass., the following officers were elected: Charles D. Rood, President and Treasurer; John C. Dueber, Clerk; Directors, John C. Dueber, Charles D. Rood, Aaron Bagg, Jr., F. N. Leonard, and F. H. Harris. President Rood in his report stated that the removal to Canton, O., had been made with less friction and expense than had been feared, that the employees at the new plant number 700 and are constantly increasing, and that they manifest fewer signs of homesickness than at first. The meeting of the stockholders having been concluded, the directors had a session and re-elected Charles D. Rood, President.

—Levi W. Groff, of Lancaster, Pa., has in his possession a very old-fashioned looking silver watch, shaped like a biscuit, which was once the property of Benjamin Franklin. The watch is of the open face pattern, and there is engraved on its back, "Ben Franklin, 1776, Philadelphia." Mr. Groff says it was the personal property of the great philosopher and was carried by him. It still keeps good time. The watch was made by W. Tomlinson, of London, and is numbered 11. In the inside of the case is Thomas Parker's advertisement of his jewelry business, No. 13 South Third street, Philadelphia, one which is written, "Mainspring and cleaning, January 24, 1817." It is reported that the owner of this relic has been offered \$1,000 a year for the use of it as an advertisement in a jewelry window.

—Jacot & Son, importers of musical boxes, are about to remove from 39 Maiden Lane to No. 298 Broadway.

—George Merritt, general selling agent of the Waterbury Watch Company, sailed for Europe on the *Adriatic* February 10.

—Franklin Thorpe, a watchmaker, of Denver, Col., recently celebrated his eighty-first birthday. He has been sixty-five years at the bench.

—Edward Holbrook, manager of the Gorham Manufacturing Company, has been elected a member of the New York Chamber of Commerce.

—John A. Worrell, Washington Court House, Ohio, made an assignment recently to Thomas Marchant. The assets amount to about \$7,500, and the liabilities to \$8,000.

—The firm of Kerr & Battin, Newark, N. J., was dissolved recently by the retirement of S. S. Battin, Jr. S. S. Battin, Sr., has entered the firm, and the business will be continued under the same style.

—A cut of the interior of T. V. Dickinson's new jewelry store at Buffalo, N. Y., received at THE CIRCULAR office, ought to be in the hands of all jewelers who are refitting their stores in the latest style.

—Wm. H. Taplin and Daniel L. Tirrell have formed a partnership to succeed the firm of Taplin & Co., 375 Washington street. Both members of the new firm were in the employ of Ripley, Howland & Co.

—W. & S. Blackinton will move on May 1 from No. 11 Maiden Lane to No. 14, into the office now occupied by H. Muhr's Sons, who have rented the office at 20 John street, now occupied by Bartens & Rice.

—The well-known diamond house of Philip Robinson & Co., London, has had an accession of membership in the persons of William Lurcott, Jr., and Max Otto Robinson. The firm name remains unchanged.

—The firm of Gardner Bros., Wadsworth, O., has been dissolved, L. F. Boyer, of that Place, having purchased the interest of D. H. Gardner. The business will hereafter be conducted under the firm name of Gardner & Boyer.

—In the list of collaborators published in the prospectus of the new Century Dictionary appears the name of George F. Kunz, the distinguished gem expert of Tiffany & Co. Mr. Kunz's department is that of gems and lapidary work.

—The assignment of Oliver Bros. has been set aside by the Court of Common Pleas. Charles J. Fox, of M. Fox & Co., has been appointed receiver of the bankrupt firm, and Paul Jones referee, to audit the accounts of Assignee Mullally.

—Kallmeyer Bros., the Detroit jobbers, have gotten out a neat little pamphlet termed the "Buyer's Helper," which they are distributing among their customers. The back cover is ornamented with a cut of the familiar "Princess" initial ring.

—H. Elcox, of H. Elcox & Co., Newark, N. J., who fell in the street accidentally some years since and severely injured his head, has been adjudged a lunatic by a regularly appointed commission. He is suffering from paresis and cannot recover.

—Charles A. Boynton, formerly with Alling & Co., has made a connection with Keller & Untermeyer, and will take Jacob Dorst's old route West and South. Mr. Boynton is a popular man on the road, and his friends will be glad to welcome him in his new capacity.

—S. H. Greenberg, 206 Kearney street, San Francisco, has formed a partnership under the style of Greenberg & Bier. Mr. Bier, the new member of the firm, has left for Europe to buy diamonds and precious stones for the firm, in which they will henceforth deal more extensively.

—Charles F. Robinson, for the past ten years with Gilbert T. Woglom, has severed his connection with that firm and taken a position with Fowler Bros., 198 Broadway. Mr. Robinson's old route will be taken by A. Martin Scott, the city representative of Gilbert T. Woglom.

—Koch & Dreyfus, of New Orleans, La., who will remove to New York City in April, have secured the old office of the Elgin National Watch Co. at 22 John street. They will retain an office in New Orleans, which will be left in charge of George Mallet, formerly their southern traveler. They are offering bona fide bargains in clocks, tools, materials and jewelry preparatory to removal.

—In the case of Tannenbaum *et al* versus Rosswog, a decision was recently handed down by Judge J. O'Brien, upon a motion by the plaintiff to continue the injunction restraining the sheriff from turning over the proceeds of the sale to the judgment creditors. The decision sustains the injunction of the plaintiffs.

—The assets of John McElree, of Charleston, who failed recently, are reported officially to be \$5,515; liabilities, \$19,314. A meeting of creditors was held recently in New York at which an offer of twenty-five per cent. was made, but the creditors are not inclined to accept it.

—The judges on horology at the Centennial Exhibition, Melbourne, Australia, have awarded the highest prize to the American Elgin National Watch Company for watches, and to the Seth Thomas Clock Company for clocks, both companies having secured the highest number of points for time keeping and general excellence in manufacture.

—James H. Hart, 313 Fulton street, Brooklyn, will move on May 1 to the corner of DeKalb avenue and Fulton street, where the business will be carried on under the name of The Hart Jewelry Co., recently incorporated, and composed of James H. Hart, Samuel T. Dauchy, Frederick G. Dow, G. W. Dimmick and D. S. Southwick. Mr. Hart's health is not good and he expects soon to sail for Cuba to recuperate.

—Henry Ginder, of A. B. Griswold & Co., New Orleans, La., who was recently elected President of the Red Cross Association, was lately elected President of the Howard Association, an organization formed in the "fifties" to relieve the suffering during epidemics. Both these organizations number among their members some of the best men in the State of Louisiana, and under Mr. Ginder's leadership the two associations will be bound in closer relationship.

—One can't but admire the enterprise of Ryan & Barrows. They have been for years prominent jewelers in this city, dealing extensively in silverware of all kinds. Their business had grown to such an extent that they found it necessary to have a silver mine of their own. Accordingly Mr. Barrows started out the other day prospecting, and very soon located a mine over in Bethlehem, which is already turning out "pay ore."—*Middletown* (Conn.) *Constitution*.

—Oscar F. Marks, a manufacturer of jewelry and jewelers' tools, at No. 142 Fulton street, died recently aged fifty-two years. He was born in Simsbury, Conn., and was educated in the common schools. Early in life he opened a jewelry store on Sixth avenue with his cousin, Horace G. Case. Mr. Case afterward bought him out, and he worked in the store for a time as a clerk, and then in turn bought out Mr. Case. He left a widow but no children.

—Jacob Dorst, formerly traveler for Keller & Untermeyer, and Joseph Jonas have bought out the interest of Joseph Noterman in the firm of Noterman & Jonas, Cincinnati, Ohio, and will conduct the business of manufacturing jewelry in all its branches, under the style of Jonas, Dorst & Co. One of their specialties is the "Ophir Diamonds." Joseph Noterman, of the old firm, has opened a shop at 203 and 205 Race street, same city, where he will continue the manufacturing and repairing business.

—The Meriden Britannia Company held its annual meeting at the factory early last month. Nearly all the shareholders were present. The following directors were unanimously re-elected: H. C. Wilcox, I. C. Lewis, George R. Curtis, W. W. Lyman, D. B. Hamilton, C. L. Mitchell, George Rockwell, George H. Wilcox and George M. Curtis. After listening to the annual report, the directors re-elected the following officers: President, H. C. Wilcox; Secretary, George H. Wilcox; Treasurer, George R. Curtis; Assistant Treasurer, George M. Curtis; Superintendent, I. C. Lewis.

—The Seth Thomas Clock Company are very much rushed with tower clock work at present. They have, within the last few weeks, made contracts for tower clocks in the court house at Bonham, Texas, school house at New Brighton, Staten Island, court houses in Pikeville and Mayfield, Ky., U. S. post offices in Lexington, Ky., and Erie, Penn., and have just contracted for a large chiming clock for the new court house at St. Paul, Minn. They have recently completed putting up a tower clock in the Lutheran Church at Osnaburgh, Ohio, a gift of A. Kountze, of Kountze Bros., of New York.

—The strike among the agate cutters of Idar and Oberstein still continues. Work is entirely suspended there, every agate cutter in the district having joined the union. The workmen are decidedly unreasonable and dictatorial in the position they take. They ask for an increase of from 20 to 50 per cent. on high priced goods and from 50 to 150 per cent. on cheap goods, and that the manufacturers should employ only union men, pay union prices and agree not to build factories of their own. While the employers were willing to concede higher wages to the cutters they did not think it right to submit to dictation, and so the deadlock continues. Only a few, and those comparatively insignificant, merchants have agreed to the strikers' terms. If the strike continues much longer it will seriously inconvenience importers of these goods.

—At the recent municipal election in San Antonio, Texas, Alexander Sartor was the victorious candidate for Alderman in his ward.

—S. Van Moppes, of D. L. Van Moppes, importer of diamonds and precious stones, arrived from Europe on the *Saale* on the 23d ultimo.

—J. Quincy Walker, well-known throughout the West, has been appointed agent for the Trenton Watch Co., with headquarters at the company's new office, 177 Broadway.

—Mr. Shiebler, of Jeannot & Shiebler, has arrived home from his visit to the Pacific Coast. In passing, we may remark that this firm keeps constantly on hand gold cases of 14 and 18 karat to fit any movement in the market.

—E. A. Thrall has leased the entire upper floor over his store in order to enable him to extend and improve his manufacturing facilities. He has heretofore occupied but one-half of it, but increase of work requires increased facilities. Mr. Thrall will sail for Europe in a few days for the purpose of purchasing new goods. He was very successful last year in finding novelties which met with immediate favor here. He hopes to be equally successful this time.

—The following concerns have secured desirable offices in the new Corbin Building at the corner of Broadway and John street: H. C. Haskell, J. B. Bowden & Co., New York Standard Watch Co. Illinois Watch Company, Fidelity Watch Case Company, Brooklyn Watch Case Company, Elgin Watch Company, Hamilton & Hamilton, Jr., Unger Brothers, C. K. Colby & Co., Wm. H. Ball & Co., Wm. C. Greene & Co., the Jobbers' Association.

—The Trenton Watch Co., manufacturers of the popular "Trenton Watch," are about to open an office in New York City to afford better facilities for distributing their product and to come nearer the center of trade. It is the intention of the company to enter the field with renewed vigor and to largely advertise their watches. They have lately increased their capital stock for this purpose, and during the past year have improved their manufacturing facilities to such an extent as to rival all competition.

—J. Eugene Robert & Co. call the attention of the trade to the superior virtues of the celebrated Monard movement, of which they are sole importers. This movement is made in Geneva, is a 16 size movement, thoroughly adjusted to temperatures and all positions, is highly finished, and is made only in the first quality. J. Eugene Robert & Co. invite all dealers who desire fine watches accurately adjusted, and complicated watches suitable for presentation purposes, to send them their orders.

—Of all the improvements which have been made in spectacles and eye-glasses during the last twenty years, the aluminum spectacles and eye-glasses of the Spencer Optical Manufacturing Co. undoubtedly take the palm. This firm are now introducing throughout the country spectacles and eye-glasses made from aluminum, which are very light and durable and resemble burnished steel. These specs are made in the regular single bow, two different sized eye, and a light flexible R. B., or an R. B. with the spiral adjustment in the butt of the bow, which adjusts itself to the varying distance between the temple and the ear. The spiral is protected by a tube or barrel, does not disfigure the spec or make it appear cumbersome, and prevents the pressure back of the ears and the ridging of the nose produced by the old style. Aluminum is not affected by moisture in the least, possesses the flexibility of gold and will never tarnish. The Spencers have been working on this for several years, but have not been able to produce the article until now. They are much elated over the success, and anticipate a very great demand from the first-class dealers, who will see at once the importance of this invention.

—The Non-Magnetic Watch Co. had a very attractive exhibit of Paillard's non-magnetic watch at the recent Convention of the National Electric Light Association at Chicago. In the case containing the watches a small electric motor was running, and a large double horseshoe magnet hanging from a golden tripod was a novel arrangement for exhibiting the non-magnetic properties of these watches. A full line of standard goods and complicated watches, including chronographs, repeaters and perpetual calendars were also shown. The exhibition was a great success, the last night's attendance being 22,000. The Non-Magnetic Watch Co. have issued a circular price list announcing their new 18 size American made watches, containing Paillard's non-magnetic balance and hair spring. With the circular is also enclosed a list of prominent jobbers who have been appointed special wholesale agents for the sale of Paillard's non-magnetic watches. Although the company have been increasing their production very materially, they find it necessary to limit the number of distributors in order to come nearer filling their orders, and make it more convenient for retailers to procure Paillard watches,

—Maass & Schrader, 65 Maiden Lane, dissolved partnership on the 15th, by mutual consent. Rudolph Schrader retires, and Wm. H. Maass will continue the business.

—Charles P. Herold, the senior partner of the late firm of Herold & Kirkpatrick, 1031 Chestnut Street, Philadelphia, will soon open a new store at 1324 Chestnut st. and devote himself entirely to the retail trade.

—L. A. Piaget & Co., Patterson, N. J., have purchased a desirable piece of property at No. 238 Main street, and will at once begin the erection of a fine four-story brick building for the accommodation of their increasing business.

—The security key, ring and chain, manufactured by Robt. H. Ingersoll & Bro., 45 Fulton street, is already in considerable demand among the jewelers. Those who want the latest thing in this line should send for samples. See their advertisement in this issue.

—L. Tannenbaum & Co., the well known lapidaries and importers of diamonds and precious stones, 65 Nassau street, are making a specialty now of unbroken lots of both colored stones and diamonds. As they do all their own cutting they are able in this way to offer exceptional bargains which the trade are not slow to take advantage of.

—Emil Irlander, the French miniature painter, who absconded from New York last fall, leaving his creditors in the lurch, has come to grief in France. He most emphatically jumped out of the frying pan into the fire, as he has been sentenced to a penal colony for 30 years on two counts of bigamy. He might better have faced his creditors than one wronged woman not to speak of two.

—News has been received in England that the Jagersfontein United Company has found a diamond of 240 karats, which is valued at over £12,000 in the rough. This is the finest and largest stone ever found at the Cape, and eclipses in value and beauty the far-famed Porter-Rhodes stone, which has hitherto been the acknowledged gem of South Africa. The name given to this remarkable diamond will be the "Pam Davison."

—The firm of L. H. Keller & Co., whose advertisement for many years have been found in THE CIRCULAR, has a reputation second to none in the "material" trade. We desire specially now to call the attention of the trade to the "mainsprings" dealt in by this house. The "Our Own" graduated mainspring, as well as the "Genuine" Jurgensen recoiling mainspring, both reliable and in the highest favor with watchmakers, are two of the specialties of this house.

—After nearly two years of legal skirmishing the famous case of ex-Senator Charles A. Yale vs. Simpson, Hall, Miller & Co., has been finally adjudicated in favor of the plaintiff by ex-Governor Henry B. Harrison, sitting as a committee of the Superior Court. The case has been one of the most bitterly contested brought to the attention of the public in many years. The report of the committee of reference completely puts the company to route and vindicates the honor and business integrity of Senator Yale and his two sons, C. B. and G. Seldon Yale. Mr. Yale sued for \$10,000 back salary and the company filed a cross complaint charging C. B. Yale and G. Seldon Yale with mismanagement of the business of the New York store, of which they had complete charge from 1870 up to 1876. The company also claimed the profit in the outside business run by Messrs. Yale at the New York store. Since the beginning of the suit Mrs. Yale, a lady highly esteemed in Wallingford, has passed away, and Senator Yale, a pioneer of the Democracy, has been stricken down with partial paralysis. He is now, however, improved in health.

—The Chicago *Herald* of the 22d ult. presents a very interesting series of squibs on the personal peculiarities of the popular jewelry salesmen for the various Chicago wholesale houses. The hits are good enough to be thoroughly appreciated by acquaintances, and the western trade can well afford to be proud of so brilliant a galaxy of representatives. Among those who are 'touched off' in these few sententious paragraphs are: Lem. W. Flershem and Peter Lapp, of Lapp & Flershem, and A. Jampolis, Paul R. Shordiche, E. E. Johnston, A. B. Towers, E. Cohen, Joseph C. Moreland, S. G. Calder, E. E. Spaulding and H. M. Tenney, in their employ; H. M. Carle, western agent of the Keystone Watch Case Co.; Julius Schnering, of Otto Young & Co., and H. G. Schram, Charles Munger, John E. Ford and Allen C. Bard, in their employ; William Wilcox and William Freund, with Cogswell & Wallis; A. N. Britton, with M. A. Mead & Co.; Charles Quene, with Benj. Allen & Co.; H. B. Cutter and Charles Spencer, with B. F. Norris, Alister & Co.; Thomas Bristol and Charles Hungerford, with C. H. Knights & Co.; and George C. Patterson and Harry Howard, of the E. Howard Watch and Clock Co.'s western office. Anyone having read the article would know them all in the dark.

—B. H. Knapp, of Smith & Knapp, 180 Broadway, sailed for Europe February 16 on the *Umbria*.

Charles W. Troughton has withdrawn from the firm of C. C. Adams & Co., 474 Fulton street, Brooklyn, N. Y.

—Henry Zimmern will shortly move into the store at No. 37 Maiden Lane, soon to be vacated by Jacot & Son.

—Armour & Weinschank, a new firm in San Francisco, have secured an office at 115 Kearney street, on the first floor.

—Bowler & Burdick, Cleveland, O., have incorporated their business as the Bowler & Burdick Jewelry Co., with a capital stock of \$100,000.

—Roberts & Yerrington, dealers in diamonds and precious stones, 176 Broadway, have dissolved partnership. Mr. Roberts retires and J. D. Yerrington continues the business at the same stand.

—It is stated that Joslin & Park, of Leadville and Salt Lake City, have offered the assignee of H. S. Porteous, Denver, sixty cents on the dollar for the bankrupt stock now in his possession, and that Joslin & Park make this offer because they desire to remove their Leadville store to Denver.

—English & Miller, manufacturing jewelers, of Newark, have made an assignment to Mrs. Beam and quit business. They are succeeded by the Leonhardt Manufacturing Company, composed of Henry Andruss, Charles E. Binder and G. H. Leonhardt, formerly employees of English & Miller.

—The jewelry trade will be represented at the Paris International Exposition, which opens in April, by the following named Providence firms: Gorham Mfg. Co., Foster & Bailey, The Sterling Company, Nicholson File Co., Thos. F. Arnold, O. C. Devereux & Co., Kent & Stanley, A. T. Wall & Co. and Henry Blundell & Co.

—A syndicate of capitalists and experts headed by P. S. Bartlett, of Elgin, Ill., is negotiating to establish a watch factory in California. At last accounts they had settled upon Otay, a suburb of San Diego, for the location of their works. The company is said to have a capital stock of \$250,000, in 500 shares of \$500 each. Work has already begun.

—The Elgin National Watch Co. have brought suit against Peter B. Simons and George S. Simons, of San Francisco, for \$50,000 damages, alleging that the defendants registered the Elgin trade mark under their own name in Australia, to the great detriment of the business of the Elgin Company in Australia. The Messrs. Simons were recently served with the papers of the suit while in Chicago.

—S. P. Howard has succeeded to the business of Howard & Moehle, refiners and smelters, 8 John street. Mr. Howard has been in the refining business for 30 years, having been connected with Geo. W. Platt for 15 years previous to embarking in business for himself, and his character and experience warrant us in bespeaking for him a continuance of the success that was the merited portion of the old firm.

—Joseph G. Ward, of Durand & Co., recently patented a process of making metallic plates for false teeth, which promises to meet the approval of the dental profession. Mr. Ward's process reduces the cost of plates from one-half to two thirds, and insures a perfect fit in every plate. The process is by electro-deposition. Mr. Ward was one of the first to successfully plate non-metallic articles with any practical result.

—At a meeting of the stockholders of the Keystone Standard Watch Company, of Lancaster, Pa., held on February 2d, the following directors were chosen: Geo. M. Franklin, George Steinman, W. Z. Sener, of Lancaster; Dr. C. M. Schellenberger and W. J. Atkinson, Philadelphia. Dr. Schellenberger was elected president, and Mr. Sener secretary and treasurer.

—President William Smith, of the New York Jewelers' Board of Trade, has appointed the following committee to confer with the New York Jewelers' Association with a view to having the Legislature enact a law restricting the operations of pawnbrokers: N. Kauffmann, of Veuve L. B. Citroen & Co., Charles J. Fox, of M. Fox & Co., and Simon Stern, of Stern & Stern.

—The fourth and final dividend of 15 $\frac{6}{10}$ per cent. in the settlement of the estate of N. Matson & Co., Chicago, was paid on the 18th of February, making a total of 90 $\frac{6}{10}$ per cent. received by the creditors on their claims. The gentlemen composing the committee of trustees, deserve the thanks of all interested for the able manner in which they have managed this settlement and brought it to so successful an issue.

—The Wolf brothers, for many years with the Pacific Jewelry Co., of San Francisco, have gone into business for themselves at 137 Montgomery street, in that city.

—The world-renowned jeweler, Charles L. Tiffany, head of the house of Tiffany & Co., celebrated his 77th birthday on February 14. After over 50 years in the harness he shows phenomenal vitality. His step is as elastic and his eye as bright as a young man's of thirty-five. He is one of the last to leave his establishment at night. Truly, this is the age of phenomenal old men, men so active and capable of business that it seems almost discourteous to call them old.

—W. F. Duryea, for twelve years with Aikin, Lambert & Co., during the last four of which he represented them on the road, has taken the management of the New York office of the New York Watch (Case Spring) Manufacturing Company, which is supplying most of the local material houses with C. G. Harstrom's Patent Adjustable Lifting Spring. All hands are busy at the factory turning out goods to supply the outside markets, and letters have been received from far and near indorsing the new spring.

—Geo. W. Shiebler has nearly completed and will have ready for rental by May 1st, his new factory on the north-east corner of Underhill and St. Mark's avenues, in the neighborhood of Prospect Park, Brooklyn. The factory is 64 feet by 85 feet, and five stories high, with basement—very substantially built with the very excellent feature of having the boiler-room, staircase, elevator shaft and plumbing, etc., outside of the walls of the main building—in other words, it is built on the "New England factory construction" plan. There is also fire-proof vaults 7x9 on each floor. Mr. Shiebler will occupy for his own use the basement and second floor. The other floors are for rental and may be subdivided. A Corlies engine of 100 horse power will furnish all the power needed. Mr. Shiebler can be seen at his store, No. 8 Liberty Place, in reference to the renting of floors or parts of floors.

—The annual meeting of the Canadian Association of Jobbers in American Watches was held at Montreal, on January 29th, at the Windsor Hotel. The attendance was large. Among the representatives of the American Association present were Mr. Fitch, of the Waltham Watch Company; Mr. Scofield of the Elgin Watch Company; Mr. Shephard, of the Keystone Watch Case Company, and Mr. Bunn, of the Illinois Watch Company. The principal subject before the meeting was the action of the American Association in rescinding its resolution which prescribed a uniformity of price with 5 per cent. discount, thus leaving the Canadian market open. This action was discussed from all sides, and its possible demoralization of the Canadian market considered. As a result a resolution was unanimously adopted expressing regret, but deciding to take no further action until the Toronto manufacturers have announced their attitude on the question, as it is the desire of the Canadian Association to continue in harmony with the American Association. The following officers were elected for the ensuing year: John Segsworth, Toronto, president; Alfred Eaves, Montreal, vice-president; E. Scheuer, Toronto, treasurer; E. A. Wills, Toronto, secretary, and Messrs. John Segsworth, E. Scheuer, A. C. Anderson, of Toronto, A. Eaves and Joseph H. Jones, of Montreal, executive committee. A bountiful banquet with toasts and speeches followed and added still further to the feeling of good will that pervaded the entire session.

—On the 14th of February, the Merritt Anti-Trust Bill went through the Judiciary Committee of the Illinois House of Representatives. Mr. Merritt, the author of the bill began the hearing by announcing that his bill was the special order and that "it speaks for itself." It was designed not to impose burdens on those who were engaged in legitimate business, but it would regulate those persons who are now unlawfully engaged in the conduct of trusts or combinations. As one of the victims he desired that F. E. Morse of Chicago be heard; and as the committee acceded to this, the gentleman gave his views at some length, prefacing them by assuring the legislators that he appeared in behalf of G. W. Brethauer, who, he said, had been forced out of the jewelry business by the National Association of Jobbers of American Watches and Cases. He then read extracts from the Constitution and By-Laws of the Association, and various circulars issued by the secretary and commissioner. After presenting these documents he added that he could protect himself, but there were hundreds of others who could not do so. He could not buy the goods manufactured by any member of the association in open market, as he was boycotted, and owing to that his trade had been impaired to the extent of \$50,000, perhaps. The bill was then discussed at some length by the members of the committee and finally reported favorably to the House with some amendments, however.

TABLE OF CONTENTS.

Advice to Watchmaker's Apprentices,	44	Complete History of Watch and Clock Making in America—Watch Case Making..	74	Jewelers' and Tradesmen's Company, The.	58	Pearls at the Berlin International Exhibition	33
Around Boston.....	58	Electricity and Magnetism.....	62	Jewelers' League, The.....	38	Paris Gossip.....	52
American Jewelers Appreciated in Japan ..	61	Fashions in Jewelry.....	41	Jewelers' Security Alliance, The.....	47	Purity of Electro-deposited Metals.....	56
The Attleboros	61	Free Hand and Mechanical Drawing	55	London Letter.....	30	Providence Notes.....	57
Adjustment of a Cylinder Watch.....	69	Factory of the Gorham Mfg Co., Providence.....	25	Mechanical Ocular Defects.....	48	Plan to Avert Fraudulent Failures.....	26
American Jewelers to the Fore—Tiffany & Co's Exhibit for the Paris Exposition..	26	Gossip of the Month.....	21-25	Marfels Watch Collection (illustrated).....	71	Quaker City Notes.....	78
Case Screws, The.....	47	Is the Stop-Work Indispensable.....	48	National Bankruptcy Law, A.....	33	Recent Patents.....	65
Chicago Briefs.....	63	In the South.....	66	New Method of Hardening Delicate Steel Parts.....	83	Trade Gossip.....	85-94
Communications.....	78			Obituary.....	83	What Waltham is doing for the Watch-makers of the World.....	56

INDEX TO ADVERTISERS.

Abry, Chas. Leo	68	Didisheim, Hipp.....	27	Manhattan Watch Co	95	Sexton Bros. & Washburn.....	40
Alkin, Lambert & Co.....	68	Downing, Keller & Co.....	3	McCall & Newman.....	45	Sheafer, W. H., & Co.....	27
Albro, S. & Co.....	Inside back cover	Evans, W. F. & Sons.....	40	Mendes, D. DeSola & Co.....	27	Simpson, Hall, Miller & Co.....	59
Alvin Mfg. Co.....	95	Faber, Eberhard.....	46	Meriden Britannia Co.....	8	Smith & Knapp.....	35
American Watch Tool Co.....	10	Fabys, Joseph & Co.....	19	Merritt, S. F.....	17	Smith, Alfred H., & Co.....	23
American Waltham Watch Co	50	Fidelity Watch Case Co.....	35	Middleton Plate Co.....	3	Smith B. & W. B.....	outside back cover
Ansonia Clock Co.....	1	Fisher & Sons.....	40	Miller Bros. & Co.....	54	Smith, H. M. & Co.....	60
Anti-Magnetic Shield & Watch Case Co..	13	Floyd, Pratt & Rounds.....	59	Miller Bros. & Co.....	54	Special Notices.....	97
Atkinson Bros	45, 75	Foster & Bailey.....	16	Montgomery & Co.....	103	Spencer Optical Mfg Co.....	7
Austin, John & Son	17	Fox, M. & Co.....	32	Moore & Horton	45	Sterling (The) Company.....	4
Bartholomew & Peckham	103	Fraser & Co.....	46	Muhrs' Sons, H.....	18	Stern & Stern.....	18
Bechtold, A.....	11	French, J. H.....	40	N. Y. Watch Case Spring Co.....	97	Sussfeld, Lorsch & Co	28
Beguellin, Tell A.....	96	Friedlander, R. & L.....	16	New Haven Clock Co.....	35	Tannenbaum, L & Co.....	28
Bedchimer, I.....	103	Glatz, Charles.....	36	Newman, Louis, Jr.....	103	Taylor & Bro.....	27
Bennett, Jacob's Sons	16	Gorham Mfg. Co.....	20	Newport Aluminum & Steel Co.....	54	Ternandt, F.....	103
Berger, Albert & Co.....	81	Groeschel & Rosman	32	New York Standard Watch Co.....	68	Thomas, Seth, Clock Co.....	Inside front cover
Birch, John S., & Co.....	96	Haskell, H. C.....	60	Nicholson File Co.....	54	Thrall, Edwin A.....	67
Blackinton, W. & S.....	88	Hausburg, O. E.....	103	Nissen, Ludwig, & Co.....	87	Towle Mfg Co.....	49
Blancard & Co.....	87	Hedges, Wm. S. & Co.....	82	Non-Magnetic Watch Co.....	91	Trenton Watch Co.....	31
Bookhout Bros	103	Heinrich, H. H.....	46	Nye, Wm. F.....	94	Troemner, Henry.....	103
Bowden, J. B., & Co.....	76	Howard, S. P.....	Outside back cover	Odenheimer & Zimmern.....	104	U. S. Mutual Accident Association	46
Briggs, J. & Sons.....	17	Hyde's Sons John E.....	88	Oliver, W. W.....	94	Valentine & Co.....	67
Brown, Thomas G., & Sons	27	Imhauser, E.....	103	Oppenheimer Bros. & Veith.....	49	Waltham Watch Tool Co.....	12
Buhler & Nanz.....	75	Jacques, Charles.....	6	Oppenheimer, Henry E. & Co.....	81	Valuable Instruction Books.....	Inside b'k Cover
Bynner, T. B.....	103	Jeandheur, F. Jr.....	28	Owen, G. & S., & Co.....	28	Wallace, R., Sons Mfg Co.....	36
Carter, Sloan & Co.....	53	Jeanne, Leon P.....	36	Pairpoint Mfg Co.....	14	Van Moppes, D. L.....	103
Cattelle & Decker.....	75	Jeannot & Shiebler.....	93	Percival, D. C., & Co.....	39	Want, Edwin.....	16
Chalmers-Spence Co.....	60	Keller, L. H. & Co.....	96	Peterson & Royce.....	75	Washburn & Moen Mfg. Co.....	103
Cheever, J. G. & Co.....	32	Kendrick & Davis.....	39	Pforzheimer, Keller & Co	28	Watchmaker, Jeweler and Silversmith..	96
Chicago Horological Institute.....	49	Kent & Stanley.....	60	Plainville Stock Co.....	39	Waterbury Clock Co.....	1
Clark, A. N.....	46	Ketcham & McDougall.....	11	Platt, Chas. S.....	Outside back cover	Waterbury Watch Co.....	79
Columbus Watch Co.....	40	Koch & Dreyfus.....	3	Prindle & Russell.....	67	Welch, E. N., Mfg Co	Inside front cover
Combremont, L.....	18	Kohlbusch, Charles.....	103	Randel, Baremore & Billings.....	84	Western Clock Mfg. Co.....	76
Conover, D. F. & Co.....	11-15	Kremenz & Co.....	93	Richardson, J. W., & Co.....	13	Wheeler, Hayden W. & Co.....	67
Cooke, B. J's. Sons	88	Lady Racine Chatelaine Watch	32	Riley, John A.....	59	Wiesbauer Mfg. Co.....	88
Cross & Beguellin.....	15	Laurencot, J. B.....	17	Robert, J. Eugene, & Co.....	87	Wilkinson, C. B.....	103
Crescent Watch Case Co.....	50	Lawson & Van Winkle.....	18	Rogers & Bro.....	9	Woglom, Gilbert T.....	45
Crossman, Chas S., & Co.....	23	Lelong, L. & Bro.....	outside back cover	Russell, Chas. A. & Co.....	Inside back cover	Wood & Hughes	27
Crouch & Fitzgerald.....	Outside back cover	Lochlin, F. P., & Bro.....	Inside back cover	Russell, Irving L.....	60	Wood, Chas. F.....	67
Cuppla, L. A	76	Logan, A. J.....	104	Sauter, L. & Co.....	28	Wood, J. R., & Son.....	103
Day & Clark.....	12	Lorsch, Albert, & Co.....	Outside back cover	Schleicher, Schumm & Co.....	45	Zineman, M. & Bro.....	32
Dinkelspiel, S. B. & Co.....	103	Mathey Bros., Mathez & Co	14	Scott, J. T. & Co.....	6		

THE VERY LATEST.

THE ANTI-SWEAR

CUFF BUTTON.

(AUTOMATIC.)

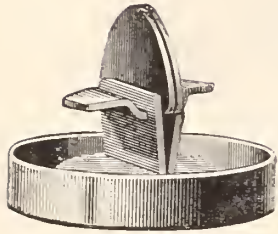

OPEN.



CLOSED.

We have now a full line of these buttons in stock of Plated and Gold Front, and expect to place on the market soon a good assortment in Gold. We warrant every pair and will sell them only to the Regular Jewelry Trade.

J. T. SCOTT & CO.,

SOLE MANUFACTURERS,

4 MAIDEN LANE,

NEW YORK.

NEW SAMPLES OF ONYX CLOCKS AND SIDE PIECES.

We beg to inform the Trade that we have received our samples of Onyx and Marble Clocks and Side Pieces, and respectfully invite buyers to inspect same.

Special Rates given for Import Orders.

CHARLES JACQUES.

SPECIALTY OF CLOCKS.

"ONYX," "MARBLE," "BRONZE," "CRYSTAL," "ROYAL WORCESTER," "SEVRES,"
"FAIENCE," "CHIMING" AND "CUCKOO" CLOCKS.

2 Maiden Lane,

NEW YORK.



THE JEWELERS' CIRCULAR AND HOROLOGICAL REVIEW.

OFFICIAL REPRESENTATIVE OF THE JEWELERS' LEAGUE, THE NEW YORK JEWELERS' BOARD OF TRADE, AND THE JEWELERS' SECURITY ALLIANCE.

It is also the Recognized Exponent of Trade Interests.

A MONTHLY JOURNAL DEVOTED TO THE INTERESTS OF WATCHMAKERS JEWELERS, SILVERSMITHS, ELECTRO-PLATE MANUFACTURERS, AND THOSE ENGAGED IN THE KINDRED BRANCHES OF ART INDUSTRY.

SUBSCRIPTION.—To all parts of the United States and Canada, **\$2.00 per Annum**, Postage Paid. To all Foreign Countries, **\$3.00 per Annum**, Prepaid.

All communications should be addressed to

THE JEWELERS' CIRCULAR PUBLISHING CO.,
189 BROADWAY, NEW YORK.

Advertising rates made known on application.



A full Index to Advertisements and Table of Contents will be found on Page 5 of this issue.

IT IS GOOD to observe that the various exchanges in this city are awakening to the fact that New York City is the great commercial center of this continent, and that not only should it control the business of it but should provide its citizens with the proper facilities for transacting such business. The Chamber of Commerce has recently brought forward a plan for the improvement of the water front on both sides of the city, a measure greatly needed and upon which too much thought can scarcely be expended. There is probably no city of its size, having such a magnificent harbor as New York, that would tolerate such inconvenient and absolutely dangerous wharves and piers as surround this city, or that would tolerate the various systems of petty charges by which the commercial interests are obstructed and delayed. It seems to have been the purpose of all persons having anything to do with our import or export trade to throw every obstacle in the way that it was possible to do, and to afford the minimum of business with a maximum of fees. There is but one pier in this city that is worthy of its name, and that is stone pier No. 1, occupied largely by summer excursion boats. The Chamber of Commerce seems to be in earnest in seeking to improve the river fronts, and the legislature will be asked to pass the

necessary laws to enable the work to be carried on satisfactorily. In the same connection it may be mentioned that a popular movement in favor of rapid transit from one end of the city to the other, upon some permanent and comfortable plan, has resulted in the formulation of a bill which the Mayor has proffered to the legislature with this end in view. The elevated railroads on either side of the city are so much better than the older accommodations formerly furnished that old residents are grateful for what they have and have seemed not to realize that anything better could be obtained. But even the elevated railroads are utterly inadequate to the demands for transportation, and morning and night they are now so crowded that one has to wait often till several trains have passed before he can find a chance to get into any car of them all. The simple fact of the matter is that the population of the city has outgrown present accommodations, for while the trains on the elevated roads are crowded to suffocation the street car lines are as liberally patronized as ever; and still the people are not accommodated. The Mayor's bill, as we understand it, provides for the appointment of a commission to devise better methods of rapid transit, and has been prepared in obedience to popular demand for such a measure. By the time this paragraph is printed it is hoped that it will have become a law, and that the work of providing adequate means of transportation—means that shall be adequate for many years to come—will have been fairly inaugurated.

* * * * *

ONE of the leading retail jewelry establishments of Chicago has dispensed with the regulation brass check given in exchange for jewelry to be repaired, and now issues in its stead a little numbered folder, containing "hints on the care of jewelry." It starts in by giving information as to the proper methods of cleaning and keeping jewelry and precious stones, the language used being exceedingly simple and devoid of technicality. This is an idea that other retailers might pattern after. Much of the complaint heard about the poor quality of jewelry and its lack of wearing qualities is due to the carelessness or ignorance of the wearers, who forget that jewelry, like the clothes one wears, requires care and occasional cleaning if it is to be kept bright and presentable. In handling or in contact with the skin while worn jewelry is apt to become corroded by the acids of the body, and dust and dirt are sure to accumulate in the crevices of the gold work. The wearer is then quite apt to blame the goldsmith for what is simply the result of his own neglect. Jewelry, it should be remembered, requires attention from time to time. If customers are reminded of this fact in some such manner as suggested above, fewer complaints will be heard from them, and the dealers' reputation will be correspondingly safe.

* * * * *

THE Secretary of the Treasury's report on the condition of trade for the first month of the current year shows the following figures: Imports of rough and glazier's diamonds, \$4,825 as com-

pared with \$13,601 last year; imports of platinum, \$53,689 as against \$44,204 in 1888. In watches and clocks little change is noted, \$99,636 worth of watches and materials have been imported this January and \$100,607 worth last, and \$14,794 worth of clocks compared with \$12,590 in January, 1888. Of jewelry, \$106,655 worth was imported this year and \$87,500 last, while the increase in importations of precious stones is phenomenal—\$893,464 as against \$565,900, or an increase of nearly 58 per cent. The export side of the statement is somewhat less favorable. Exports of clocks fell off about 25 per cent. (\$116,344 to \$93,287); exports of watches about 75 per cent. (\$30,161 to \$7,661)—an exceptionally low figure and not to be considered a criterion of our foreign trade in watches. The jewelry exports were \$14,075 less than during January, 1888, an increase of \$11,310 in the value of plated ware shipped to foreign countries is slightly encouraging if it be not merely a temporary spurt. The legitimate inference from this and the preceding schedules that have appeared in THE CIRCULAR is that our export trade is not developing apace with our manufactures and our population.

* * * * *

"EXCELSIOR" is contributing a series of valuable articles on magnetic influence, which alone are worth a year's subscription to any watchmaker.

* * * * *

THE quarterly report of the patent department gives the following resume of the extent of inventive activity in the jewelry and kindred trades during that period: number of patents on jewelry, 12; number of patents on watches, cases, and parts thereof, 18; number of patents granted on clocks, timepieces and parts thereof, 20; number of optical patents, 4. The growing importance of alloys in watchmaking is proved by the issue of 13 patents of this kind, one on a non-magnetic alloy.

* * * * *

A GOOD idea of the growth of our trade with Canada may be gleaned from the Blue Book of 1888. American watches, cases and jewelry have all but displaced the foreign articles. In 1880 the value of watches, watch movements and cases imported was but \$116,967, against \$560,606 in 1888. The value of the United States exports in this class of goods in 1880 was \$61,877, and in 1888 \$420,371. During the year Switzerland contributed \$11,366 and Great Britain \$14,480. The total import of jewelry and plated ware in 1880 was \$630,041. In 1888 this sum reached \$1,645,538, which, however, shows a slight decrease compared with the figures of 1887, which showed a total of \$1,662,766.

* * * * *

Chas. S. Crossman's interesting articles on the history of the watch case and clock industries of the United States will run for two years more.

* * * * *

NO wonder Germany and France are walking away with what little export trade we ever had. The German Export Society has decided to build the Floating Exhibition Palace of Germany, having raised 5,000,000 marks for the purpose. The plan is to sail from port to port showing the superiority of German wares. "International exhibitions," says the prospectus, "do not occur often enough, and must be supplemented in this way." The vessel is to be called the *Kaiser Wilhelm*, and will be the work of the German shipyards, and upon a scale more magnificent than that of any craft afloat. According to plans the ship will be 172 m. long, 20 wide and 14 high. It will have four engines propelling as many screws. The material will be principally German steel. The cost of a two years' tour is estimated at 3,150,000 marks. The income from the rented space—1,000 to 1,200 marks for each booth—and from sales will be,

it is thought, at least 7,260,000 marks, leaving a balance of 4,110,800, or over 2,000,000 marks annually—a pretty sum on the pages of the ledger. Emperor William has promised his aid to the enterprise, and it is hoped that the vessel will sail from Hamburg on her first voyage in the spring of 1890.

* * * * *

See the handsomely illustrated serial on the *Marfels Watch Collection* at *Frankfort, on the Main*, commenced in the *December* number.

* * * * *

IN a recent interview a prominent manufacturer outlined a plan he had devised for averting fraudulent failures, and of all the schemes which have come under our notice this seems most to merit a fair trial. The chief defects of existing boards of trade are unwieldiness and want of prompt decisive action. Before any steps can be taken toward the prosecution of offenders, meetings must be held and a good deal of red tape spun off. Debates developing conflicting individual interests occur to cause delay and hamper the efficiency of the organization. Action is taken *too late* to be of much service. In matters of this kind an ounce of prevention is worth a pound of cure, for in setting out to fight an assignment after ample time has been given the suspect to meet the attack even a board of trade shoulders a herculean task, fraught with baffling delays and heavy expenses, as experience has time and again shown. Co-operation under such circumstances does little more than provide a fat jack-pot for lawyers to squabble over. What is wanted is a purpose definite, single and more aggressive and an executive power vested in the hands of one competent man or, at most, in a triumvirate, as suggested by the manufacturer. At the slightest indication of unsoundness, even when trouble is scented afar, an investigation of the books of the concern should be made immediately without frittering away time in general sessions. This should be done in an orderly and legal manner. No honest man ought to be afraid to open his books for the inspection of creditors, and if any objection is offered the creditors have the very best ground for calling in the aid of the law. The skeptical may point out as the weak point in this plan the difficulty of getting business men to share with their competitors any inside information they may possess, but this objection would be removed if an arrangement were made with a reliable mercantile agency to receive at once by telegraph all premonitions of failure, such as protested notes, etc., and, furthermore, we may as well recognize first as last that without some occasional sacrifice of individual interests for the common good, no combination whatsoever can be anything but a rope of sand. A policy like that outlined would do more in six months to rid the trade of pestilent failures than present methods will accomplish in as many years. The plan has every appearance of being feasible and effective, and the boards of trade already organized should carefully consider the wisdom of adopting it wholly or in part.

* * * * *

ANOTHER daring robbery has occurred in the South, not very far from the scene of the Chapman & Gale burglary, at Norfolk, Va., and has directed the attention of the trade again to the large number of retail dealers who persist in neglecting the privileges of the Security Alliance. After a successful career of six years, during which perfect immunity from losses of this sort has been the happy lot of the members, it would seem a work of supererogation to rehearse the exploits of the Security Alliance, nor will we take the time to particularize them here. But another jeweler has been found unprepared in "the day of visitation," and a sermon of some kind ought to be preached on this text for the sake of the others that are equally defenseless. Last call and fair warning. Any retailer who

ALFRED H. SMITH & Co.,
DIAMONDS,

182 BROADWAY, NEW YORK.

LONDON:

33 HOLBORN VIADUCT.

CHICAGO:

125 STATE STREET.

Attention is invited to the following importations:

Matched Rubies.

A pair of superbly matched rubies, extra choice in color, nearly $2\frac{3}{4}$ carats and very showy for the weight. Price, \$ G X E C.

Ruby, $3\frac{1}{2}$ carats.

One round ruby of good color and extraordinary brilliancy and perfection. Price, \$ G X E C.

5 carat Diamond.

A round blue-white gem—absolute perfection. We believe it to be the finest stone of the weight for sale in the United States. Price, \$ I C E E.

Pearl Necklace.

55 pearls, 335 grains. A necklace of remarkable brilliancy. Price, \$ A C I E.

We shall advertise from time to time goods of especial rarity, putting the prices in cipher, a key to which we will forward on application.

Respectfully,

ALFRED H. SMITH & CO.

reads this exhortation and still neglects to join the Alliance, is hopelessly doomed, and should forfeit the prayers of the faithful.

* *

* *

* *

A CORRESPONDENT of one of our leading dailies writing from London, recently, says: "Flowers are worn scarcely at all at night now, and it is curious to know how conspicuous they are by their absence. Jewelry is the one thing to wear, especially diamonds and pearls. So marked is this fashion of the moment that some people who happen to possess fine pearls and diamonds wear them all at once, necklace over necklace, brooch upon brooch. It is quite the correct thing to pin four or five diamond brooches on one side of a low-necked bodice, all close together. I look at the arrangement with wonder, unable to see the beauty of it. However, now is the moment for exhibiting every precious stone one possesses, for wearing trinkets that are old-fashioned or new-fashioned, and for wearing them just as it pleases one's fancy." Nothing gives THE CIRCULAR more unalloyed pleasure than to see newspaper correspondents and fashion writers lending a hand in the good work of reviving interest in jewelry, and if these leaders of the people will but keep their eyes open and report what they see without garbling or exaggerating, they are bound to become our faithful allies.

* *

* *

* *

IT IS the universal opinion of experts that the exhibit of jewels prepared by Messrs. Tiffany & Co., especially for the Paris Exposition, and recently placed on view in this city, represents the highest attainment of the jeweler's art in America. The collection, which is valued at \$500,000, is the result of several years of patient thought and study. The object of the designers, according to the plan that had been adopted, was, as far as possible, to utilize the rude, yet characteristic Indian and aboriginal forms, and the best of later American models, also employing American gems largely in the decoration. The result of all this painstaking labor is simply bewildering to the beholder. It reflects the highest credit on the heads of the house of Tiffany & Co., heads on which, to be sure, high honors rests easily, and warrants the belief that in making this exhibit they were actuated not so much by the desire of self-aggrandizement as by a patriotic determination to put the American jeweler in the foreground at Paris among all the competing nations. To this patriotic enterprise and the marvellous skill with which the ideas have been carried out, the trade will be chiefly indebted for the distinction that is quite certain to perch on America's banners there, and we deem it our privilege and duty as a trade organ to extend to Messrs. Tiffany & Co. the hearty congratulations of the jewelry trade on the signal success which has crowned their efforts.

* *

* *

* *

Dr. Eucklin's valuable articles on "Mechanical Ocular Defects," a thorough elementary treatise, began in the February number. Subscribe now and have the series complete.

* *

* *

* *

INQUIRIES are from time to time received at THE CIRCULAR office from young men residing in the east who wish to take a course in watchmaking, and prefer not to go west to do it. To all such we are obliged to say that to our knowledge no such school exists in the east although the west is fortunate in possessing several good watchmaker's schools. A number of abortive attempts to start such enterprises have been made in New York of recent years, but the men at the head of them apparently lacked the qualifications which ensure success. These fiascos should not prejudice the cause. The time is ripe now for the establishment of a good horological

school somewhere in the eastern States. THE CIRCULAR feels assured that under proper management such an institution could be made a financial success from the start, and could rise to a position of permanent usefulness in this section of the country. A stock company would perhaps be the best form of organization. Many members of the trade who might be induced to take stock in a sound, well-officered company. The opportunity seems to be waiting for the man.

* *

* *

* *

THERE is strong likelihood that a bill designed to regulate the pawnbrokers' business will be passed by the legislature of New York State this session. Some time ago William R. Alling, President of the Protective Union, in conversation with ex-District Attorney Lyon, explained to him the need of such a bill, and advised him to earn the lasting gratitude of the jewelry trade by drawing up one in suitable form and endeavoring to pass it through. Mr. Lyon evidently saw the force of the situation and acted on the suggestion, for among the new bills presented late this session was one aiming at the restriction of certain abuses in the pawnbrokers' trade, the chief safeguard proposed being a clause requiring the pawnbrokers to report to police headquarters every night a full and accurate list of all articles pawned, together with the names of those who pawned them. This regulation is in force in a number of cities, and has been found very effectual as a deterrent to those who are tempted to steal, and as a convenient reference to those who have missed articles of jewelry during the day. The unanimous support of the trade should be given to this measure to secure its enactment into law at the earliest possible day, as no valid objection can be raised against such a preventive check.

* *

* *

* *

Call the attention of editors of your local papers to "Elsie Bee's" "Rambles Among the Jewelers," and have the items reprinted. It will increase your trade.

* *

* *

* *

IN an interview recently the Persian Minister at Washington told some very plain truths about trade in general, and trade in particular between Persia and the United States. He said: "The purpose of the Shah in sending a minister here is to make commercial compacts to the interest of both countries. Your minister to Persia has encouraged us to take this step, and we hope to open up a mutually valuable interchange of commerce between the two countries. We would rather American enterprise should find profit in the development of our railroads and telegraph than that they should fall into the hands of nations at rivalry with us. You must have our products, and you buy them from other people at four or five prices. We want your products, and have to get them indirectly at greater expense. You might as well buy directly from us and sell directly to us. Our merchants are ready to bring their goods and wares here. They are waiting to hear from me. And our people are ready to buy the products offered by your merchants and inventors. We make shawls, rugs, carpets, silks, velvets and woolens, such as cannot be had except from Persia. We have a large mineral wealth, gold, silver and precious stones. Our diamonds are fine, and all the turquois used in the world comes from Persia. Your people offer things we do not make. The conditions are such as to conduce to the commercial advantage of both, and the distance not too great—twenty five days' journey. Why should not a large trade be carried on between the two countries in American vessels?" The gist of these remarks lies in the statement, "You might as well buy directly from us and sell directly to us." Our present roundabout system of foreign trade is decidedly unprofitable.



HERE has been much comment in the trade for the past year regarding the new buildings to be erected by the Gorham Company, on the site selected by them at Elmwood in the City of Providence, and many opinions have been expressed regarding the decision of the Company, but the universal conclusion has been, that whatever was decided upon by them would be carried out on a broad basis, and with activity of an aggressive nature. But unless one has recently visited the scene of this new enterprise he can have no conception of the magnitude of the undertaking, or the amount of work already accomplished. A visitor would now find a vast amount of work already finished, and unless he fully realized

pleted, is shown in the illustration. The great features of these new buildings will be the abundance of light afforded in every room, and every portion of the buildings will be literally as light as "all out of doors."

The general form of the main buildings is that of an elongated letter H. This shape was not selected by any hap-hazard process; but was the result of long consideration on the part of Mr. George Wilkinson, who has for many years been the superintendent of the Company, and who is the designer of this plan of buildings as best suited to the needs of the business. In this work Mr. Wilkinson has been ably assisted by Mr. F. J. Sheldon of Providence.

The buildings are: first, the one which is devoted to offices, pack-

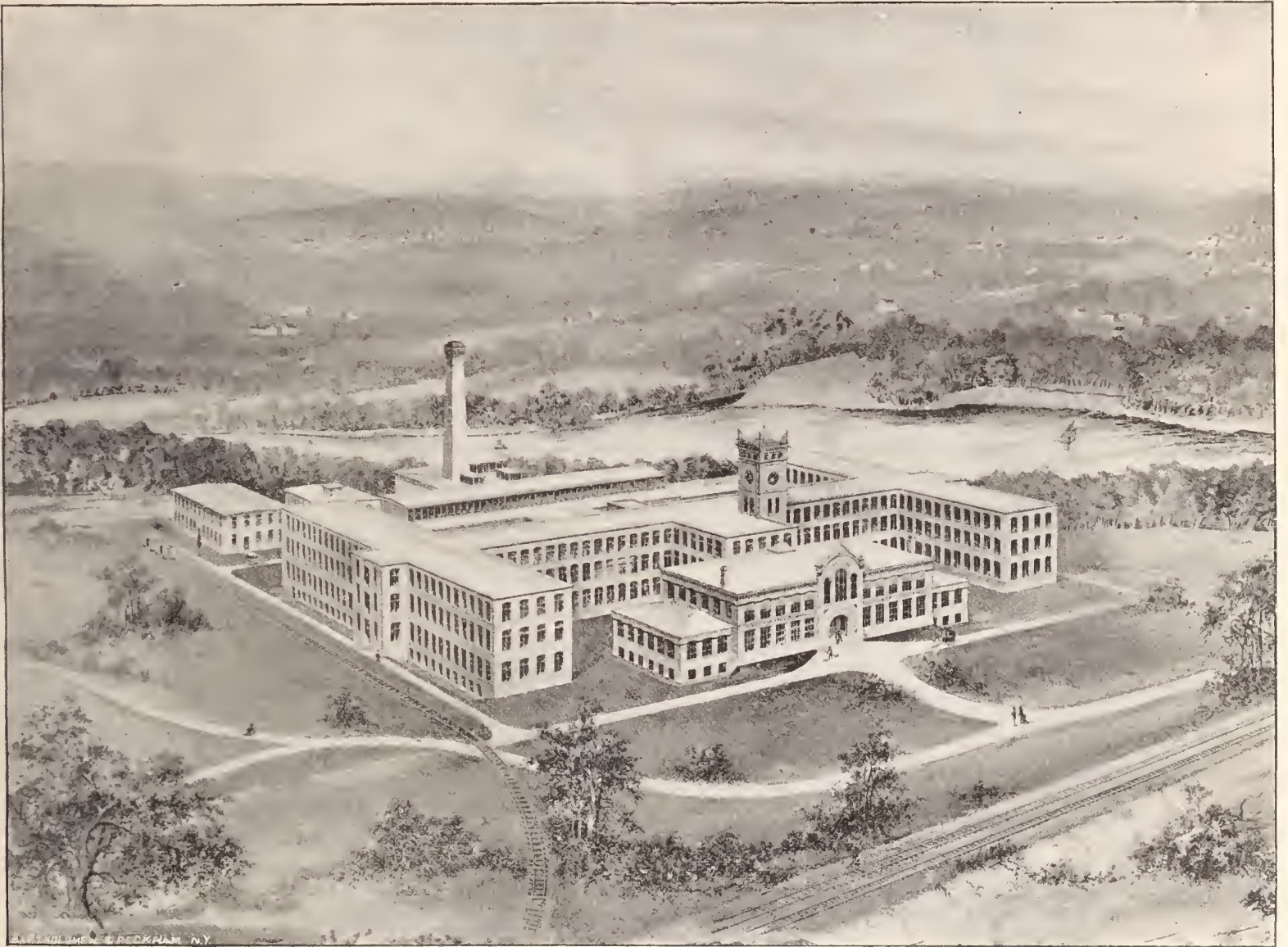

Factory of the Gorham M'f'g Company, Providence, R. I.

the facility for doing such work by contractors who are up to the present times, he would be amazed.

The Company owns a tract of land comprising nearly 15 acres, being 950 feet on the Providence & Stonington R. R., running back 700 feet on Adelaide Avenue, admirably situated for its intended purpose, rising from the line of the railroad fifteen to twenty feet and wooded with well-grown trees, just sufficiently to give an air of picturesque beauty to the whole plot. The building itself will stand on the elevated plateau about 250 feet back from the railway. The waters of the Mushapaug Pond are a part of this property, and the Company have acquired valuable privileges in the way of this supply for their works.

The general view of the works as they will appear, when com-

ing, charging, shipping, 200 ft. by 65 ft. on the ground floor with basement below, which will be used for supplies. The second floor of this building will contain stock rooms, designing and modeling rooms. The building next in rear of this is 50x50 and leads on each floor to the main factory building, as follows: one main building 419 x 44 ft. and 3 stories high, north wing 244 x 44 and south wing 256 x 44 feet. The entrance for workmen being by the way of two tower buildings nearly in center of the two wings. These towers or porches are 15 x 36 feet, and are of fire-proof construction, and in addition to these there is the center tower, 20 feet square, and containing iron stairways and elevator. In the court formed by this long main building and the two wings, is found the great room called by Mr. Wilkinson the preparatory room. This is intended

to be a magnificent room 205 feet long by 80 feet wide, with light on four sides, and also from the monitor roof, which will be 38 feet long and 12 feet wide. In this building are the foundations for the great stamps, presses and rolls, which have been especially planned for doing the heavy work required of them. One hundred and two blocks of granite form the foundations for the stamps alone, making with the rubble work an almost solid mass of stone 80 feet long and 12 feet deep. In addition to these buildings are the engine and boiler rooms, 67 x 73 feet; the blacksmith shop, 49 x 42 feet; the carpenter and wood working shops, 100 x 45 feet, and two stories high; the foundry, 64 x 40 feet. The chimney stack, already completed, as are the last three buildings named, is 121 feet high and 12 feet square at base. The buildings already completed show the thorough method of construction employed in this work, and the whole group will have the appearance of good material, well put together. The steam plant has not yet been decided upon, but it will be ample for supplying the power for the present and future needs. The lighting will probably be by electricity, while heating and ventilation will be combined by the latest improved Sturtevant system. Everything will be done for the comfort of the employees. The company expect to complete these buildings and remove their works early in 1890, although certain departments will doubtless be employed there previous to that date. It will be unquestionably the finest silverware factory in the world; and with such a magnificent plant as this as a foundation, the Gorham Company is certain to win new laurels in the future.

Plan to Avert Fraudulent Failures.



AN outcome of the recent Payne-Steck failure, a prominent member of the trade suggests a scheme by which such fraudulent acts as those perpetrated by Payne may be prevented. Let, say, ten manufacturers, in whom the whole community have entire confidence, organize and elect a president, vice-president, treasurer and secretary, and then appoint an executive committee of three, without further accession of membership. The constitution and by-laws should contain two essential principles of organization. First, the requirement, in each case of failure, before settlement, of an examination of the books and assets of the bankrupt by an expert accountant and appraiser, and this should be *mandatory* in every case. Second, they should make a settlement with every honest creditor who could show that his failure was legitimate, and compel their members to accept such settlement as the executive committee decided could be equitably paid out of the assets by the bankrupt. If an examination were refused, the best counsel that can be obtained in the place where the failure occurs should be employed to drive that man out of business, even if they get nothing more than the assignment would pan out, which, in the majority of cases, would be trifling, and take one judgment for the balance of their claims, assigning them all to the treasurer of the organization, in order to lessen the expense of obtaining the same. Immediately after organizing and electing their officers, whose term should be three years, let them call in every other manufacturer to join them on that platform, each member of the association to pay in one hundred dollars initiation fee, the money to be deposited in a trust company where it will draw interest, and nothing to be done until that fund reaches the sum of ten thousand dollars, which, of course, it would require one hundred members to do. They then have a capital already established to do business on, pay expenses of an expert accountant, prosecutions of offenders against law, either civil or criminal, and the obtaining of judgments. The practical working of the scheme would be this: We would have an organization which could not be altered in less than three years at the will or pleasure of any who might happen to be caught in a big failure, which, per-

haps, might be the very first one they would have to handle. It would prevent the acceptance by anyone of any compromise. There would be no saving clause, as the executive committee would have to proceed in that way, and would not be compelled to make assessments to meet each particular case. The very moment a failure is announced, the secretary calls the executive committee, which should consist of the president, and in his absence the vice-president, treasurer and secretary of the organization. They must take immediate action, telegraph to an expert accountant to go to that debtor firm and demand, in their behalf, an immediate examination of the books, and if this is refused they would then telegraph to attorneys in that city and retain them at once to take such legal measures as the laws of that State would permit, to obtain such examination. Or if that were not possible, to protect the interests of creditors the secretary would, immediately on taking action, notify each member to send his claim, properly verified, to the secretary with a proper assignment claim. The advantage of this scheme is that there would be no necessity for delay such as calling meetings of creditors to take action, whereby much valuable time is lost, and matters concealed, books fixed up, etc.

Detectives could also be properly employed by the association to trace concealed property, etc., in many cases. Besides preventing such bare-faced robberies as have occurred in the trade during past years, it would facilitate settlements in cases of bankrupts who were honest, though perhaps unbusiness-like in their methods, without frittering away the estate with legal and other expenses of an assignment. In case an examination of the books is made, the necessary evidence to convict would be then attainable. Whenever the fund is exhausted, let them assess another hundred dollars on the members, keeping the funds well in hand. A few applications of this remedy would deter others from swindling operations. Perhaps a second assessment would never be necessary.

American Jewelers to the Fore.

TIFFANY & CO.'S EXHIBIT FOR THE PARIS EXPOSITION PLACED ON VIEW.



THE STRIKING feature in the collection that will constitute Tiffany & Co.'s display at the forthcoming Paris Exposition, leaving aside its magnitude, value and beauty, resides in its being of thoroughly American character. Not only did the artisans whose hands wrought these beautiful objects receive their training in the Tiffany shops, but the designs of the principal part of the collection are of pure American character, being a refinement to the point of perfection of the graceful and quaint forms which have been unearthed among the rude implements made by the native American Indians. The chief designer, George P. Farnham, to whose genius the country is indebted for the collection, is as much American as it is possible to be. He, like his uncle, C. T. Cook, is a member of the firm, and his special study is the designing of jewel work.

The designers have availed themselves of the discoveries of Lieutenant Cushing and other explorers, in the buried cities of the Zuni Indians, of Arizona, and of the Chillkat Indians, of Lynn Channel, Alaska. These archæological features of the exhibit will be perhaps more highly appreciated on the other side, for several European explorers have visited Alaska, and devoted more time to investigation of its aboriginal condition. The basket work of the Navajos Indians has suggested some of the designs; some owe their origin to the Dakota Sioux, as well as to the Hupa Indians, of Colorado.

Great variety, striking originality of design and high quality of workmanship characterize the gold, silver and enameled jewel goods. To prove the capability of the artisan to produce any kind of work, and to do it as well, if not better, than its originators, a few patterns of French origin in the styles of Louis XIV., Louis XV., Louis XVI.

and the days of the Empire, together with Hungarian, East Indian and Japanese art are given. The work of preparation of this display occupied Mr. Farnham for more than two years, and some of the masterpieces having been in the artisans' hands for even a longer period. And to add emphasis to its Americanism, many of the articles in the collection are embellished with native gems. George F. Kunz, the firm's widely-known gem expert and mineralogist, will take charge at the exhibit of a complete collection of native precious stones, many of the finest specimens known in the rough, as well as many beautiful cut stones, which Mr. Kunz has devoted years to collect. A large number of pearls, some of great size are shown, together with the shells in which they were found. In the display will be noticed three-fourths of all the varieties of precious stones found in the earth, some specimens of which are among the finest known, notably the garnets and tourmalines.

The fancy cases in which the jewels are contained are covered outwardly, with leather made of the skins of black panther, black coon, lizard, alligator and chameleons, and are lined with natural elk, ooze calf and reindeer skins. Then there are boxes made of California redwood, Alaska cypress, maple, cherry, etc.—all native woods.

The total display numbers about 200 pieces, valued collectively at \$500,000. Below are given descriptions of the principal objects, taken from the official list:

- Brooch*.—Shape taken from the carved wooden masks used by the medicine men of the Chillkat Indians, Alaska. Brown pearls from Tennessee.
- Brooch*.—Shape after the decoration in basket work of the Hupa Indians, California. Pink pearls from the Miami River, Ohio.
- Brooch*.—Shape from the decorated horse-hide shields used in warfare by the Sioux Indians. Dakota pearls from the Cumberland River, Tenn., and emeralds.
- Brooch*.—Chrysanthemum, rubies, diamonds and canary brilliant.
- Brooch*.—Decoration, study from the Sitka Indians (Esquimaux), Alaska. Tourmaline from Maine.
- Brooch*.—Decoration, "Bur Marigold," wild flower of the Southern United States. Pearls from Tennessee.
- Brooch*.—Decoration, study from the Sitka Indians (Esquimaux), Alaska. Tourmaline from Maine, and golden beryl from Connecticut.
- Brooch*.—Decoration, study from American shell bark (hickory nut). Garnets from Arizona.
- Brooch*.—Pearls from the Miami River, Ohio, and green sapphires from Montana.
- Brooch*.—Decoration, "Florida Palm." Aquamarine and Tourmaline from Maine and garnets from Arizona.
- Brooch*.—Black pearls from Lower California.
- Brooch*.—Decoration "Aster." Cinnamon diamonds and sapphires in decarbonized steel.
- Brooch*.—Green pearls from the Cumberland River, Tenn.
- Ring*.—Decoration and shape taken from the Navajos Indians, New Mexico. Sapphire.
- Ring*.—Decoration, study from basket work of the Hupa Indians, California. Tourmaline from Maine.
- Ring*.—Decoration, Sioux Indians; study of "Prairie Wolf."
- Ring*.—Decoration, "Arrow leafed Violet." Pearls from the Miami River, Ohio, and sapphires from Montana.
- Ring*.—Decoration, study from the Indians. Garnets from Arizona.
- Ring*.—Decoration, study from the Sitka Indians, Alaska. Garnets from Arizona.
- Ring*.—Ruby en cabochon from India and pearl from Miami River, Ohio.
- Ring*.—Pink pearl from the Miami River, Ohio, and brilliants from Brazil, South America.
- Ring*.—Pearl from the Miami River, Ohio, and brilliants from Brazil, South America.
- Vinaigrette*.—Decoration, "Forget-me-not" and diamonds. Watch set in top.
- Vinaigrette and Bonbonnière*.—Decoration, "Bunch of Violets,
- Vinaigrette*.—Decoration, gold filigree and rough sapphire rock crystal from North Carolina.
- Vinaigrette*.—Decoration, diamond and enamel smoky rock crystal from North Carolina.
- Vinaigrette*.—"Rosebud," decoration in gold; study from Chillkat Indians. Rock crystal, diamonds, emeralds and moonstones from North Carolina.
- Vinaigrette*.—Bear and bee, decorative Japanese "American gold" smoky rock crystal from Colorado.
- Vinaigrette*.—"Trumpet Creeper," gold and enamel.
- Sleeve Links*.—Decoration, study from the Navajos Indians, New Mexico. Garnets from Arizona and Amazon stone from Virginia.
- Sleeve Buttons*.—Decoration, study from the Sioux Indians. Moonstones from Virginia.
- Sleeve Buttons*.—Decoration, study from the Zuni Indians. Opal agate from Mexico.
- Sleeve Links*.—Decoration, Hupa Indian; study from the dentalium shell used as wampum or money. Hollastonite from New York.
- Sleeve Links*.—Decoration, study from the Cherokee Indians. Amazon stone from Virginia.
- Sleeve Links*.—Decoration, study from the Inuit Indians, Alaska.
- Sleeve Links*.—Decoration, study from quilt work of the Sioux Indians, Dakota. Rhodonite from Massachusetts.
- Sleeve Links*.—Decoration, study from the Navajos Indians, New Mexico. Wollastonite from New York and fossil coral from Iowa.
- Sleeve Links*.—Decoration, study from the Inuits, Alaska. Fossil coral from Iowa.
- Sleeve Links*.—Decoration, study from the Sitka Indians, Alaska.
- Sleeve Links*.—Ruby en cabochon and jade; East Indian.

- Lace Pin*.—"Heliotrope." Enamel and diamonds.
- Lace Pin*.—"Mignonette." Enamel and diamonds.
- Lace Pin*.—"Sweet Elysium," Enamel and diamonds.
- Lace Pin*.—Decoration, cactus, New Mexico. Emerald from North Carolina and pearls from Tennessee.
- Scarf Pin*.—Purple pearls from the Cumberland River, Tenn.
- Scarf Pin*.—Light green pearl (Lower California) and rattlesnake, United States.
- Watch and Chatelaine*.—Style, First Empire. Enamel, diamonds and peridots.
- Watch and Chain*.—Decoration, "Hungarian."
- Watch*.—Decoration, "Apple Blossom." Rose diamonds.
- Watch and Chain*.—Lapis lazuli, rose diamonds and rose topaz.
- Watch*.—Decoration, "Fringed Gentian," United States. Sapphires and diamonds.
- Pendant*.—Decoration, study from the Chillkat Indians, Alaska. Cinnamon diamonds.
- Pendant*.—Decoration, canvasback duck. Aquamarine from Maine and brown diamonds from Brazil.
- Pendant*.—Decoration, study from basket work of the Navajos Indians, New Mexico. Garnets from Arizona and spessartite garnet from Virginia.
- Pendant Bonbonnière*.—Sapphires.
- Necklace and Pendant*.—Pearls from the Miami River, Ohio, and from the Cumberland River, Tenn.
- River Brilliant Necklace and Pendant*.—Decoration, hazelnut bud.
- Diamond Necklace*.—Decoration, United States. Study from flower "Mountain Fringe."
- Diamond Necklace*.—Style, "Colonial," 1776.
- Diamond Necklace*.—Style, "Empire," 1800.
- Bracelet*.—Garnet from Arizona and Tourmaline from Maine.
- Bonbonnière*.—Agurite, malachite and rough garnets from Arizona.
- Bonbonnière*.—Turquoise from New Mexico and rock crystal from North Carolina.
- Bonbonnière*.—Gold and enamel. Pearls from Tennessee.
- Bonbonnière*.—Decorations, Limoges enamel, fait à la point in gold.
- Match Box*.—Decoration, study from the Hupa Indians, California. Turquoise from New Mexico.
- Match Box*.—Decoration, Chillkat Indians; study of a "Crow." Abalone pearls from California and Turquoises from New Mexico. Iron and gold.
- Match Box*.—Decoration, study from the Zuni Indians, in gold and enameled rhodonite from Massachusetts.
- Hair Ornaments*.—Sapphires and Rose diamonds.
- Card Case*.—Lizard skin, natural color, from America. Gold wire work with sapphires.
- Purse*.—Decoration, chased gold and pearls woven in bead work of the Sioux Indians. Pearls from the Cumberland River, Tenn.

The pearls mentioned above, taken from the Miami River, Ohio, form a portion of the collection of I. Harris, of Waynesville, Ohio, who devoted twenty years to gathering them, and who disposed of the entire collection to Tiffany & Co. The natural supply is now exhausted.

FULLER DESCRIPTIONS OF A FEW OF THE ABOVE.

Perhaps the most conspicuous object is a corsage diamond ornament, representing a lace work of diamonds, about 2,000 in number, and is intended to extend from the shoulder to the waist. Its value is set at \$27,000. But this gorgeous ornament is even outshone by another. It is a large diamond necklace composed of innumerable brilliants, the center diamond of which weighs $25\frac{3}{16}$ karats, is valued alone at \$45,000, and is said to be a finer stone than any sold at the famous sale of the French crown jewels of 1887, and is the second largest diamond in the United States. The necklace is valued at \$175,000.

The famous Tiffany yellow diamond will not, as was at first reported, appear in the exhibit.

A necklace in the colonial style of '76, containing five large yellow diamonds, one of which is 77 karats in weight, and is cut to such exquisite perfection that it can stand perpendicularly on its collet. It is the second largest diamond in the United States, vies in beauty a brooch nearby, of innumerable black pearls from Lower California, valued at \$22,000.

A cat's eye brooch in East Indian style, worth \$8,700, with five magnificent specimens, and a beautiful collarette set with sapphires *en cabochon*, and another collarette drop piece of the style of Louis XVI., with a large white pearl, $\frac{2}{3}$ of an inch across, in the center, are among the superb pieces.

A remarkable object is a watch chatelaine made of Peridot's chrysolite of a delicate olive color, which peculiarity bestows upon it another name—olivite. The jewel contains one of the largest specimens known. Then there is a brooch, representing literally a shower of alternate diamonds and sapphires. They hang delicately suspended from a large size diamond.

Among the enamel flower work are many beautiful specimens in breast pins, brooches, ear rings and vinaigrettes of entirely original design, and of a superior class of workmanship to that ever done in

this country. Orchids in fully twenty-five varieties, with diamond stamens and emerald stems, are among the noticeable; a chatelaine watch set in a wild rose. The gold is 18 karat and the execution is beyond criticism.

The silverware department will be liberally represented. Foremost is the great Tiffany tea set, which has been loaned for the Exposition. It consists of six pieces and a large salver, each article being a mass of the most exquisite *repoussé* work, the design being in tiny flowers, fruits and leaves, no two being alike.

There are many specimens in the Japanese style, many of which are inlaid with American gems. Stained ivory and pearls, rhinoceros horn set with turquoises, abalone shells and other novel combinations have been used with fine effect, many of the designs emanating from the brain of E. C. Moore, under whose special supervision the work was produced. The shapes of many of the vases and coffee and tea pots follow the graceful lines of the Saracenic, Persian and East Indian, but the main portion of the display, hand mirrors, letter slips, ink stands, etc., are purely American, combining Indian basket work.

In addition, there will be a display of pistols and revolvers, on which are handsomely etched sporting scenes, and in which are inlaid copper-niello and turquoises. They are magnificent specimens of art, and will excite exclamations of surprise from the visitors at the Exposition who expect to behold some roaring Texan blunderbusses, and the future French duellist, being winged with a bullet from one of them, can turn his face to the wall with a feeling of profound satisfaction that it was no common revolver that worked his destruction.

The whole exhibit is really the first attempt at a purely American art in jewel work, and the result is eminently successful, for the designs are not only original, but beautiful, while the workmanship is perfection itself.

About two-thirds of the display was shipped on the 23d. The whole was fully insured.

On Friday, March 29, Tiffany & Co. opened an exhibit of precious stones found in the United States, and forming part of their exhibit for the Paris Exposition. It is the most complete collection of the kind ever seen, and contains many of the finest specimens in the natural crystalline form, as well as many of the finest cut stones. In addition to the more familiar ones such as sapphire, ruby, emerald, garnet, turquoise, peridot, tourmaline, aquamarine and yellow beryl, there are a number of rare stones probably cut for the first time for jewelers' use, *i. e.*, pectolite, wollastonite, samarskite, dumortierite, beryllonite, etc. Some of these specimens were kindly loaned by leading collectors, while the others are the result of several years of careful search for this purpose by Tiffany & Co., George F. Kunz, their expert, having made special visits to some localities to obtain specimens. Mr. Kunz will have charge of the exhibit at Paris, sailing thither per steamer *Gascogne*, April 13. Fuller details will appear in THE CIRCULAR when the exhibit is put in place at the Exposition. The exhibit will be continued at the store of Tiffany & Co. on Monday and Tuesday, April 1 and 2.

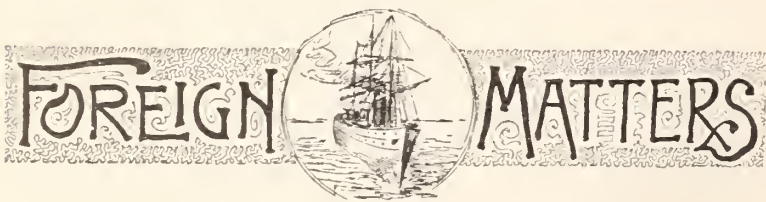

[FROM OUR SPECIAL CORRESPONDENT.]

THE MILLINER COMES TO THE RESCUE.—LONDON AND PARIS COMPARED.—A TENDENCY TO IMPROVE THE QUALITY OF IMITATION JEWELRY. LONDON, March 10 1889.

There has not been any perceptible variation in our jewelry trade since the commencement of the year. The general remark in our factories in and about London, is that the orders received during the past month have not been either so many or so large as those of the previous month but the orders executed by our manufacturers, the general business of our factors (jobbers) has been maintained.

That better times have commenced for the producers of the more expensive varieties of jewelry is undeniable. One great incentive to this improvement is the gradual relaxation of that very rigid style of costume which has for some time prevailed among ladies. The tight fitting and somewhat masculine fashions which ladies have adopted for some time have not been good media for the display of expensive ornamentation. But it appears that this austerity is relaxing, and that it is expected to give place to the more simple, and, in my

opinion, more lady-like style of some few years ago. This may seem a not very suitable subject for a man to write upon, but as the prevailing fashion in ladies' attire has a great deal to do with the amount and quality of jewelry ladies wear, the matter is an important one as affecting our trades. The manufacturing jewelers will hail with delight the return to a style of dress that will admit of the wearing of sundry articles of jewelry that have for some time been laid aside.

I have had no opportunity of judging how your manufacturers or retailers are affected by the caprice of the time, but ours find it necessary to watch the probable turn of events and, as far as possible, to prepare for the change of the public mind. I was much struck with the effect of this in Paris. It is something surprising, even in these days of wonder, to notice how greatly the varying political conditions in the French capital have affected the jewelry trades there. Since the election of Boulanger for Paris, the admiration of the ladies for him has taken a very noticeable form. It is well known that the general has a great partiality for carnations, and consequently these flowers (or pinks) are made the emblems of political opinion. In the street, the concert, the ball room, the opera, in fact, wherever Parisian ladies assemble the favorite flower of the general is seen. Diamonds and rubies are made up into this flower and are in great demand, to the joy of the French jeweler. It is to be hoped they will be able to execute all orders before the craze subsides. We are not subject to such ephemeral changes in London. We have our periods of fashion, but if they are not of such sudden growth they are more lasting.

Enameled jewelry is very much in vogue in Paris at the present time. My recent stay in the capital was a very brief one, but the few shops I had the opportunity of visiting had each sundry specimens of these articles. They are made special features and are prominently shown. Renaissance ornaments in dead gold and a pierced background are very effective, especially those which are set with choice stones. Smaller specimens of enameled work in oxidized silver are bracelets and brooches, but the larger pieces are more numerous. Everywhere in Paris are preparations for the forthcoming Exhibition, and especially for the visitors it is expected to bring to the city. The Parisian jewelers are quite alive to the importance of the occasion, and are acquiring some interesting and unique souvenirs of the event, of which it would be premature to speak at present.

Coming back to our home trade and in connection with some recent remarks of mine about imitation jewelry, my attention has just been called to some very appropriate mounts for imitation diamonds. These mounts have hitherto been produced in metal gilt and silver, but C. E. Cramp, of Birmingham, has produced some in 9 karat gold, finished bright. This improved style is sure to be appreciated. The article is at least a veritable piece of jewelry, if the stones are not what they seem. I am still of opinion that manufacturers will do well to foster the taste for *temporarily* wearing imitation jewelry. It preserves the desire to have jewelry, and the effect must be that sooner or later the wearers will seek to possess the real in lieu of the imitation. The fact that there is a demand for expensive mounts for these imitations proves my contention that with improved times the imitations will be replaced by genuine stones.

The Merchandise Marks Act is being actively used to secure perfectly accurate descriptions of watches and other articles exposed for sale. A test case, instituted by the London Watch Trade Association, has just been decided, and a well-known watchmaker, A. Campbell, of Cheapside, has been fined £5 and £20 costs, because his assistants sold a watch to which had been applied a false trade description as to the place and country in which it was made. There was no personal imputation against the vendor of the watch, who, in addition to the fine and costs, returned the money that had been paid for the watch.

Manufacturers have been taking active measures in relation to the plate duties and compulsory hall marking. A meeting was lately held at Sheffield to consider these questions, and it was unanimously decided to represent to Mr. Goschen (our Chancellor of the Exchequer) that the trade desired that hall marking should continue to be compulsory. Those present were not quite so much agreed as to the plate duty. The question was fully discussed, and a committee appointed to forward the views of the Sheffield trades to the Chancellor of the Exchequer.

When the office of the Rothschilds was opened for the sale of stock in the Burmah ruby mines recently, so great was the pressure that some shop windows opposite were broken in, and the force of police on duty, though considerable, was altogether insufficient to manage the crowd. Many persons were obliged to enter through a window. The list was closed at 12.30, with subscriptions representing many millions, while the total amount of capital to be allotted is only £200,000.

VIGILANT.

A National Bankruptcy Law.



N THE MONTH just past, the National Bankruptcy Law Convention held a session at St. Louis. This convention is made up of representatives from the various Boards of Trade and commercial exchanges of the country which have taken action in favor of a national bankruptcy law. This is a question upon which THE CIRCULAR, as our readers will remember, has taken advanced ground for a number of years, insisting that such a law was necessary for the protection of the commercial interests of the country. The convention discussed the subject in all its phases. The committee previously appointed to draft a bill made an unsatisfactory report to the effect that there was not time to prepare a satisfactory bill. This provoked considerable discussion not particularly complimentary to the committee, which concluded its labors by recommending the convention to endorse the Lowell bill. This course was opposed on the ground that the Lowell bill has now been before Congress several years, and, not having met with the approval of that body, seems to be lacking in some essential features. This opposition, however, was ineffectual, as the report of the committee was finally adopted, so that it stands that this latest convention of commercial representatives is on record as having given its endorsement to the Lowell bill now before Congress, and which has heretofore been very strongly endorsed by numerous commercial organizations throughout the country. The convention urged this measure upon Congress as embodying the best views yet formulated for a national bankruptcy law. A resolution was also adopted expressing the sense of the convention to the effect that whatever law on the subject of bankruptcy should meet the approval of Congress "should embody provisions for the economical and speedy administration of the assets of bankrupt societies; for fixed charges for all offices based upon salary and not upon fees; for the recognition of the exemption laws of the several States; for the prompt and certain punishment of the bankrupt for all criminal acts or fraud; for the speedy discharge of all honest debtors, and for the expeditious distribution of the assets of bankrupt estates by the payment of dividends."

This action is important and should be productive of good results at the next session of Congress. The subject is brought forward at this early season to enable the commercial bodies of the country to express their views upon it, and to concentrate their influence to induce Congress to take favorable action upon the Lowell bill. This bill passed the Senate more than a year ago, but failed of favorable action in the House of Representatives. It belongs to that class of legislation nearly affecting the interests of so large a portion of the community that final action upon it is bound to be had at no very distant period. How long such action may be delayed remains largely with the trade organizations of the country, for if they unite in impressing upon the members of Congress the importance of such a measure they are sure to be listened to favorably. As it is not probable that there will be an extra session of Congress, a new year will have dawned before action upon such a bill can be had; meantime organized efforts should be made to secure the endorsement of every commercial body in the country, for every person engaged in trade and commerce has an interest in such legislation. The history of legislative efforts upon the bankruptcy question has been a record of blunders; but this only affords additional reason for wiser action at the present time. The necessity for uniformity in practice of the several States in dealing with insolvent estates is too apparent to be open to discussion. When the country has suffered heavily from

commercial panics, bankruptcy laws have been enacted with a view to meeting special emergencies; but these have invariably been defective and so inefficient as to become intolerable and their repeal has been demanded. Such was the case with the national bankruptcy law that was in existence a few years ago. The numerous opportunities it presented for fraud proved too heavy a load for it to carry, and consequently its repeal was demanded and acquiesced in. But scarcely was the law repealed when business men, finding themselves left to the defective bankruptcy legislation of different States, began to clamor for a new national law. In obedience to this demand the Lowell bill was prepared, was endorsed by a very large number of commercial bodies and presented to the Forty-Eighth Congress. It was favored by a majority of both houses, but by parliamentary tactics was defeated at that session. It was brought up again at the next session, but again it failed of passage, because mainly of the admission of so many new members to that body. And this is the condition in which it stands now. A new Congress has been elected and will be called upon at its next session to take action. It is somewhat singular that, while the Senate passed the bill as originally presented to it, some of the senators changed their views and became opposed to it. In fact, there has been a tendency shown to make this a political measure, and to load it down with riders tending to sink it. If these tactics are continued there seems to be little hope of its becoming a law. But politicians in the Senate or out of it have to understand that this is not a political measure in any sense whatever, but is a measure of relief from existing abuses that the commercial community, irrespective of politics, demands. THE CIRCULAR has heretofore warmly advocated this measure, and it will continue to do so until something better appears or until it is enacted into a law. We trust the various organizations of the jewelry trade will take early opportunity to express their views upon the subject and to co-operate with the committees of the National Bankruptcy Convention.

Pearls at the Berlin International Exhibition (1880).

Continued from page 38, March, 1880.

PART II.—FRESH WATER PEARLS.



FRESH water pearls are less valued as a rule than the Oriental pearls, because of their inferior luster. Of these there was a very interesting exhibit in the Japanese department (No. 45 of the special catalogue). The varieties *Anodonta Japonica* (Dobu-gai) and *Cristaria Spatiosa* (Karasu-gai), together with a number of the small, beautiful, colored pearls which they produce, were represented by fine specimens.

China exhibited no pearls proper, but under Nos. 143 and 144 of the special catalogue were large river oysters or mussels, *Dipsas plicatus* (Chipang), from the ditches of the district of Mingpo, and especially such examples as on the inside of the shells show small Buddhistic images brought out in natural relief by a homogeneous layer of nacre substance secreted by the oyster itself, and not formed by cutting. The propagation of these Buddhistic oysters is a separate industry, carried on by the monks in some of the monasteries of the district of Mingpo. After the oysters have been cautiously opened, small pictures of Buddha moulded in tin are placed between the mantle and the shell and the animals are returned to their environment in the ditches for two or three months. After this short time the layer of mother-of-pearl is found to be of sufficient thickness for the purpose and they are removed.

The unio species so numerous in American rivers yield fine pearls. Dr. H. Schaffer, of Cincinnati, Ohio, exhibited some imperfectly defined forms of these unios and pearls produced by them, No.

26,092 of the American special catalogue. The European river oyster, *Margaritana Margaritifera*, is of greater value as a pearl producer. Exhibits of this oyster and pearls from it were made from Russia as follows: (1) By Baron Fridolf Lindner, of Swarto, Finland [No. 1,485 of the common catalogue], rewarded with honorable mention on account of the beautiful color of the pearls; (2) By Mr. Wilhelm Gomilewski, of St. Petersburg, pearls from the province of Olonez, where they are often used as ornaments for women's caps, the latter mostly ornamented with artificial pearls, being exhibited together with photographs showing how they are worn [No. 1,486]; (3) Mr. C. Jagerhorn, of Ulcaborg, Finland [No. 1,488 of the general catalogue].

Pearl oysters were exhibited from all the principal German districts where they occur. Although the pearl oyster is found throughout Germany wherever swift, clear-flowing rivers or brooks cut through calcareous or primitive rock, they occur in large quantities only in the following regions: (1) The streams of the Bavarian Forest between Regensburg and Passau, *i. e.*, in the tributaries of the streams rising in the Fichtel mountains, or on the southern slope, in the water shed of the white main and the Eger, and on the northern slope, in the water shed of the Saale, southward from Hof, and, especially numerous, in the White Elster. The whole of the first district belongs to Bavaria, but of the second district only a part belongs to Bavaria, the region of the White Elster appertaining to the Saxon Crown. The Bavarian pearl oysters were exhibited by the jewelers, Joh. Nep. Koller, of Windorf, owners of the pearl brook near Vilshofen, in the Bavarian Forest (No. 120 of the general catalogue, honored with a bronze medal). First in a number of large aquamarines were a number of living oysters, then a mass of dried shells, some of the average size and others larger and showing deformities, such as fast-grown pearls, etc. Then came a glass box in which the softer parts of the animal, including examples of pearls in their natural layers, were preserved in alcohol, and last, a bigger box containing figures and designs framed by black, brown and white pearls grown by Mr. Koller. Mr. Koller has also become interested in the problem of producing artificial pearls in the oysters by the method in use by the Chinese to produce the Buddhist pictures previously described. He casts flat tin figures, *e. g.*, fishes, in wooden molds, and places them between the mantle and the shell, opening the shell by means of a peculiar pair of tongs similar to a pair of pincers with flat, filed and rifled jaws. When closed this instrument is easily introduced between the lips of the shell, and then it is opened by means of a screw which separates the handles and regulates the distance of the jaws from each other. The examination of the oyster, to determine whether it contains pearls, is effected by means of an iron. The flat, bent end of this iron is introduced into the opening at the back of the oyster, and then turned to bring it athwart the shell. The pearl oysters of the northern district were represented by a collective exhibition of the Royal Saxonian Pearl-fishing Privilege and the industrial branches connected with it. In order to make a satisfactory exhibit of this industry the Royal Ministry of Finance, the Ministry of the Interior, the Board of Directors of the Royal Collections in Dresden, had acted in co-operation (Nos. 117, 118 and 119 of the general catalogue, honored with an address of thanks to the Saxon government and a gold medal for excellence). The exhibit, which was ornamented with the Saxon coat-of-arms and the scutcheons of the principal cities of the pearl-fishing district (Planer, Oelsnitz and Adorf), was designed to give a complete idea of the Royal Saxon Pearl Fishery, with respect to history, natural history and industrial statistics.

The Saxon pearl waters in Voightland are: the river Elster, from the watering place of that name to a point below Elsterberg, and its tributaries, the Muhlhauser, Freiburger and Marieneyer brooks; the Hartmanusgruner, the Triebel brook, the Ebers and Gornitz brook, the Trieb, the Mechelsgruner, the Treibe and Loch brook, and, in addition, some 28 mill ponds. Only the upper part of the Elster and the Muhlhauser brook runs through mica slate formation, *i. e.*,

through micaceous rock. In the regions near the source of the Trieb, which are not pearl-bearing, the rock is granite feldspathic rock, while the Elster as well as all the other tributary brooks have their bed in phyllite and transition rocks, *i. e.*, in phyllites, argillaceous slate, "graywacke" quartzite, compact limestones, flinty slate with its diabasis varieties and tufas (?). Some of these rocks, like the limestones and the diabases, contain lime. All these peculiarities were fully illustrated by charts. The waters of these various brooks and rivers had been analyzed by Dr. Councle with the following results:

	Of the Elster near Oelsni z.	Of the Trieb.	Of the Goernitz brook.
Solid residue 140 C.	3.97	5.20	4.00
Loss of these remains by a little red heat.	0.94	2.33	1.77
Residuum by red heat.	3.03	2.87	2.23
These contained:			
Silica (Silicic acid)	0.73	0.55	0.50
Lime	0.60	0.62	0.53
Magnesia.	0.40	0.57	0.33
Carbonic acid	0.53	1.12	0.77
Sulphuric acid.	0.46	trace.	trace.
Chlorine.	trace.	"	"
Phosphoric acid.	"	"	"
Iron.	trace.	trace.	trace.
In the water was found:			
Nitric acid.	trace.	noticeable trace.	trace.
Ammonia.	"	"	"

For these facts I am indebted to the kindness of my friend, Prof. Credner, director of the Geological Survey of Saxony. It is impossible to give more accurate details because the recent geological maps do not include these districts.

For the oxidation of the reducing substances contained in 100,000 parts (according to Kubels' method) there was used:

	Elster near Oelsnitz.	From the Trieb.	From the Goernitz brook.
Oxygen.	0.24 gr.	0.24 gr.	0.22 gr.

These are the waters in which the river pearl mussels live, and, although the oysters are not so numerous now as they once were, thanks to the care of the Saxon government, they are still quite numerous. They rarely occur singly, generally in small banks or beds, contiguous to each other, though in certain favorable spots extensive banks are found. One of the chief attractions of the big aquarium mentioned above was an artificially prepared bed, composed of living oysters. After the young of the oyster have proceeded from the egg into the germinal sack (?), like the young of all the unionid, they live parasitically for some time afterwards on fresh water fishes. The microscope shows the embryos and the primitive parasitical stage of kindred species. After a considerable lapse of time they appear in the waters, where they slowly develop until they attain a length of 15 cm. Quite a series of these from 14 to 18 cm. long were exhibited. In process of time their vertebrae are consumed by the carbonic acid contained in the water and finally disappear altogether, the soft parts of the oyster sometimes becoming exposed. The shells of the dead oysters are gradually disintegrated by the action of the water. A series of such partially disintegrated oysters was exhibited, and also a number showing the position of the oysters in the brook and a chart or diagram of their anatomy prepared by the forest academy of Tharand. There were also oysters preserved in alcohol and transverse sections affording a view of the soft parts. In considering the question of the nature and formation of these pearls, the structure and quality of the shells is of interest. The shells consist of three strata: first, the outer yellow or brown conchioline (cuticula); second, the prisms stratum composed of piles standing vertically against the shell surface; third, the nacre layer, composed of finely folded leaves generally parallel to the shell surface. This formation of the shell surface was illustrated by transverse sections

and microscopical grindings, the microscopes being supplied by the firm of Schiek, Berlin. These two last strata consist chiefly of carbonate of lime. On the inside of the oyster nearest the edge the cuticle is free, then from the outside inward comes the prism stratum in a narrow zone and last, lining the rest of the inside, the nacre stratum. These layers are separated from the corresponding parts of the soft mantle that lines the shell. Now, if foreign bodies, such as grains of sand, eggs or parasites, enter the mantle, or small indurations of the tissues are formed, then the mantle forms a capsule around these foreign bodies as malformations, just as the muscle of the hog forms the parasitic trichinæ, in order to deprive it of the power to harm. The capsule is formed from those secretions that are natural to that part of the mantle, and thus are formed concretions lying free in the mantle, which, especially when they are of large size and regular, round shape, are called pearls. The nucleus of fresh-water pearls usually consists of prism substance, the prisms radiating from one point, like the radii of a ball. Sometimes thin, concentric cuticular layers alternate with these prism layers, and in most pearls the surface is covered with a layer of nacre substance. If this is thick, clear and iridescent, the pearl is valuable; if not, then the pearl is worthless. Whenever a wound has been received by the oyster in the soft parts, the tissues are apt to be moistened with limey substance. This often happens in the "closing" mussels, and the irregular concretions thus formed are called "sand-pearls." Some of the pearls exhibited were composed of cuticular substance, others of prism substance, while still others were covered with mother-of-pearl. Besides there were microscopic pearl sections. In all the cases mentioned so far the pearl was shown lying in its mantle surrounded by its tissues. In certain cases, however, where the growth is abnormally strong, the pressure exerted by the pearl upon the outer wall of this tissue pocket becomes so strong that the pocket is absorbed on the edge towards the shell, bringing the hard pearl directly against the shell. Of course it is then impossible for the pearl to grow any more at the point of contact, for there is no tissue to secrete the lime substance. But it grows on the rest of its substance, and the thickening layers, as they are formed, pass directly into the nacre layers on the inside of the shell, which serve to thicken the shell itself. Through these overlayers the pearl is connected with the shell as though by different layers of covering cloths. At first it clings to the shell at one point only, and then over a wider area. Hence arise twin or united pearls, of which quite an extensive series was shown, taken from the Royal Zoological Museum in Dresden and the Zoologisch cabinet of the Academy of Tharand.

It is certain whatever be the manner of formation, that a pearl can be formed only at the expense of the shell, as every substance necessary to its growth is drawn from the source. It is not to be wondered at, therefore, that the presence of a pearl can be detected on the outside of the shell. Normal looking oysters rarely contain pearls; while, on the other hand, deformed ones often contain pearls of great beauty.

The signs on which the pearl fishers rely for detecting the presence of pearls from the outward aspect of the shell are chiefly three. First the thread, a recess or elevation extending from the vortex to the edge. Second, the kidney-like shape of the shell, *i. e.* an indentation on the ventral side, and third, the contortion of both shells toward the middle plane of the animal. These three characteristics, as well as some others of great interest, were exemplified in the collection.

Attempts to make use of the pearls from the Saxon pearl district are very old. In the middle ages the Venetians in their hunt after gold and precious stones found the treasures which lay hidden in these waters, and afterwards the inhabitants of the Voightland made use of them for ornament, until in the year 1621, the electoral prince Johan George I., at the instance of the Oelsnitz cloth manufacturer, Moritz Schmirler, raised pearl fishing to a royal privilege and

appointed Schmirler his first pearl fisher. From that time on until the present day the Voightland pearl fishery has remained a royal prerogative, and with a single exception (at the close of the 17th century, the father-in-law of the Schmirler, one Abraham Thumler, enjoyed the privilege), all the pearl fishers, twenty-one in number, have been direct descendents of the second pearl fisher, Abraham Schmirler, who in the year 1643, succeeded his brother Moritz. The family name has since been changed to Schmerler. The present pearl fishers are the cloth maker, Moritz Schmerler, Sr., and his two nephews, Moritz and Julius Schmerler.

Copies of the original grants and oaths which the second pearl fisher had to take at his appointment on the 2d of July, 1643, as well as a pedigree of the Schmirler family, so far as the pearl fishery is concerned, were all exhibited, together with a very interesting monograph. The Royal Saxon Pearl Fishing Privilege, by Dr. J. G. Jahn, entitled "Pearl Fishing in the Voightland; its topographical, natural and historical aspects, written and illustrated from the best sources, and accompanied by full documentary evidence; illustrated and edited; published by the author, Oelsnitz, 1854." This work is still to be had of his widow in Oelsnitz. There was also the general work by Th. v. Hessling, "Pearl Oysters and their pearls, natural and historical, described with reference to the pearl waters of Bavaria, with eight plates and one map, Leipsic, 1859. Published by W. Engelmann."

The administration of the prerogative is so conducted that the superintendence of all the pearl waters is given to the pearl fishers, who themselves are under the control of the chief inspector of forests for the district of Auerbach. The fishers now act in accordance with the general instructions issued June 15th, 1827, under the advice of Dr. Thienemann. The inspection of the waters is made in the spring with a view to removing all the obstructions such as drift-ice and new buildings that would injure the pearl banks. If deemed necessary, they sometimes remove a whole bank that is in jeopardy to a more secure place. The search for pearls is forbidden to commence until the season is far enough advanced to enable the pearl fishers to stand for hours in the water without being chilled. The whole district is not searched over every year, but it is divided into 313 tracts, each a day's work for three pearl fishers, and of these rarely more than twenty or thirty are searched a year. Hence, every district lies untouched for from ten to fifteen years, and the oysters have abundant time to produce. At searching time the fishers often wade up to their waists and every oyster on the banks of a given district is opened by means of a specially constructed iron instrument.

When it has been ascertained whether a shell contains a pearl or not, it is, in the latter case, thrown back into the water, but in the former the shell is opened by cutting the closing muscle with the sharp end of the iron. The pearls that have been taken out are generally kept in a bottle of water at the home of the pearl fishers, and when they have been thoroughly cleaned they are dried. When small pearls are found, which it is hoped will grow larger in time, the fishers mark the date upon the shell with the pearl iron and return the oyster to its haunts. Good pearls are often found in shells marked in this manner.

The pearl fishers distinguish four different qualities of pearls, clear, half-clear, sand pearls, and damaged pearls. In the latter class belong all those which consist either of prism substance only, or of cuticular substance only, and consequently, are brown or black in color and have no luster. Even rose colored and green pearls occur, and if lustrous, are highly valued. The product of the pearl fishery for some years is known from the time of the original grant. For example, in the year 1649, Abraham Schmirler produced fifty-one large clear pearls, forty-two small clear ones, thirty-two half clear, fifty-nine damaged and forty-two black pearls. Only since 1719, however, the year in which the Voightland, by reason of the extinction of the royal Saxon collateral line of Maumburg-Zeitz,

reverted to the Electorate of Saxony, has a complete record of the annual product been kept. That record is as follows :

In the years	Clear Pearls.		Half-Clear Pearls.		Sard Pearls.		Damaged Pearls.		Total.	
	Amount.	Average per year.	Amount.	Average per year.	Amount.	Average per year.	Amount.	Average per year.	Of all Pearls.	Average per year.
1719-1739	1809	90.45	727	36.35	1200	60.0	552	27.6	4288	214.4
1740-1759	1412	70.60	578	28.65	485	24.25	281	14.05	2751	137.55
1760-1779	1042	52.1	272	13.6	427	21.35	219	10.95	1960	98.0
1780-1799	1261	63.05	243	12.15	357	17.85	179	8.95	2040	102.0
1800-1819	1603	80.15	261	13.05	325	16.25	203	10.15	2392	109.6
1820-1839	1659	82.95	340	17.0	325	16.25	326	16.30	2650	132.5
1840-1859	1884	94.20	610	30.5	388	19.4	505	25.25	3387	169.35
1860-1879	1618	80.90	682	34.1	450	22.5	514	25.7	3264	163.2
In 161 yr's.	12288	76.32	3708	23.03	3957	24.57	2779	17.25	22732	141.19

Every fall the summer's yield is turned over by the pearl fishers to the office of the Royal Forest Com. at Auerbach, whence it was formerly taken to the Royal Cabinet of Natural History, or the Directors of the Royal Collection at Dresden, but is now handed directly to the Royal Minister of Finance. The product is generally sold every year, and the total proceeds of these sales from 1830 to 1878, as stated in the public documents on exhibition, amounted to 29,886 marks. In former times it was the custom to gather the pearls and keep the finest until it was desired to use them for some noble jewel or ornament. This was the origin of the famous Elster pearl necklace deposited in the Dresden Green Vaults, and loaned for the centerpiece of the Saxon Exhibition. It was formed of 177 pearls of an aggregate value of 27,000 marks. The nine most beautiful pearls found since 1719, weighed 35 carats each, and were valued at 85 thalers apiece.

It is worthy of note that in the year 1802 pearls of the value of 7,000 thalers were taken from the cabinet of natural history and sold to jeweler Newling, the money being applied to purchase of the Count Racknitz mineral collection. In the year 1826 forty-three very beautiful pearls were used in an ornament for the Duchess of Tascana. The entire yield for 1879, and the most beautiful find of the past few years, were placed on exhibition, the latter, valued at 3,000 marks, having been loaned by the regular buyer, the Court Jeweler, Sachwall, of Dresden. Not satisfied with the small natural yield of pearls, the fishers have attempted to aid the productions of them by artificial means. In the Saxon pearl waters Dr. Kuchenmeister, assisted by the senior pearl fisher, Moritz Schmerler, made a number of valuable experiments. Two ways have been tried. Small foreign bodies have been introduced into the mantle by some means in order to furnish the nucleus for the free pearl formation ; or the Chinese method of inserting these bodies between the mantle and the shell has been followed, the bodies becoming coated with nacre substance. Of the results of this second method some very good examples were exhibited. The foreign bodies which had been introduced were either poor pearls from other oysters, pieces of grain or china buttons, all of which were seen to be entirely covered with nacre substance. Unfortunately the shape of these objects is such that the mantle cannot fit closely around them, and hence the nacre covering is always so irregular that it is quite out of the question to make any use of these artificial pearls. To show that our oysters will cover a plain relief with nacre as well as the Chinese, a shell was exhibited on which a little relief head had been produced, as was described at the beginning of this article. This shell is of the Royal Zoological Museum at Dresden. Efforts to make the river pearl oyster available in any other way than as a pearl-bearer have met with better success. In 1850 Moritz Schmerler conceived the idea of cutting small fancy articles out of the shells. These proved so successful that the government allowed Mr. Schmerler to take what shells he needed for his manufacturing business from the royal brooks. Large numbers of pearl oyster pocketbooks and sacheis

have been made since then, the almost faultless white and reddish tinted "Rosa pearl oysters" being specially prized for this purpose, as it can be cut so thin that a photograph pasted on the inside can be seen through the shell itself. This industry is not developed to any great extent by the pearl fishers themselves. Other manufacturers engaged in it as soon as its success became apparent, and the supply of home material proved insufficient for the demand without depleting the brooks altogether. The industry did not suffer from this cause, however. Many hundred thousand pearl oysters are used every year at Adorf, the chief seat of the industry, the chief source of supply being Bavarian and Bohemian brooks owned by private persons but likely soon to be depleted by the demand.

When nacre manufacturing had once become established as a Saxony industry, European material did not suffice, but foreign material was imported in large quantities until finally a process was discovered for manufacturing the metal objects necessary for the mounting of the cut articles of mother-of-pearl, and thus originated the present nacre industry of Adorf, which gives employment to hundreds of workmen and has a world-wide renown. Several of the prominent firms participated in the exhibition—C. W. Lots, Louis Nicolai and Leonhard Bang showing the raw materials in the different stages of their manufacture, and a great variety of finished articles. The materials used, in addition to the river pearl oyster, are the sea mother-of-pearl oyster (*meleagrina margaritefera lam*), both the white and yellow West Australian and the black Polynesian varieties ; the *haliotis iris cheni* from New Zealand, the *iris* snail and the *turbo marmoratus* from the East Indies, and the bogus snail. Mother-of-pearl is also occasionally obtained from the *Placina sella L.* from the East Indies, the Indian *Avicula a la Corri cheni* and the *Perna rul sella Lam*, the *Pinna nigrina Lm.* from the Red Sea, the Indian *Mytilus viridis L.* and the North American river oysters, *Unio alatus Say*, *U. varicosus Lea*, *U. oblique Lam*, *U. circulus L.* (the latter generally erroneously called by the trade the "Scotch pearl oyster") ; also the *Turbo pica L.* from the West Indies and the *Haliotis californiensis*. All these mollusks, named and described by Prof. v. Martens, Berlin, were well represented at the exhibition. Still, others are occasionally employed in the mother-of-pearl industry. The articles on view showed the high degree of perfection attained. The largest objects were an inlaid plate, a collet and a lamp stand, and some sawed and sculptured photograph frames.



President, HENRY HAYES.....Of The Brooklyn Watch Case Co.
 First Vice-President, JAMES P. SNOWOf G. & S. Owen & Co.
 Second Vice-President, ROBERT A. JOHNSON.....Of Celluloid Enamel Co
 Third Vice-President, JOSEPH B. BOWDENOf J. B. Bowden & Co.
 Fourth Vice-President, CHARLES G. LEWIS... ..Of Randel, Baremore & Billings.
 Secretary and Treasurer, WILLIAM L. SEXTON.....Of Sexton Bros. & Washburn.

EXECUTIVE COMMITTEE.

GEO. H. HOUGHTON.With Gorham Mfg. Co.
 WM. H. JENKS.....With Tiffany & Co.
 A. A. JEANNOT.....Of Jeannot & Shiebler.
 GEORGE R. HOWE.....Of Carter, Sloan & Co.
 WM. BARDEL.....Of Heller & Bardel.
 J. R. GREASON.....Of J. R. Greason & Co.

At the regular monthly meeting of the Executive Committee of the Jewelers' League, held on Friday evening, March 1, there were present the Chairman, Geo. Howe, President Hayes, Vice-Presidents Snow and Johnson, and Messrs. Greason, Jeannot and Sexton

Requests for change of beneficiaries were received from eight

members, all of which were approved and the desired changes made. Six members were reinstated.

The following members have been admitted since the last report:

Max Dorenfield, Bastrop, Texas, proposed by Julius Dorenfield; James J. Fogerty, New York, William S. Ginnell, Brooklyn, N. Y., proposed by John W. Senior; Chas. Silverstein, Meridian, Miss., proposed by David Marx and Moses Weiss; Chas. M. Fuller, Jacksonville, Fla., proposed by J. Crosby, Jr.; Jos. Herspring, Santa Barbares, Cal., proposed by J. O. Scharlin; Chas. Moe, Chicago, Ill., proposed by Alex. Pinover; Albert H. Ruth, Shelbyville, Tenn., proposed by John W. Ruth; James C. Sehorn, Athens, Tenn., John O. Sehorn; H. W. Shattuck, San Francisco, Cal., proposed by Geo. S. Simons; O. Shields, New York City, proposed by G. T. Pearsall; W. R. Stammers, Cheyenne, Wy. Ter., proposed by H. E. Buechner.

Fashions in Jewelry

A Lady's Rambles Among the Jewelers.

THE late inaugural ball gave an admirable opportunity for observing the freedom with which American women, as a rule, indulge in personal ornaments. As the attendance at this ball was restricted to no one grade or clique, it fairly represented the taste and fashion of every station of society and every section of the country. A notable feature in the toilets was unquestionably the very lavish display of jewelry. Not only did the *creme de la creme* exhibit faultless gems mounted with great taste and originality, but one saw much jewelry in which mediocre stones appeared, sometimes with harmonious and pleasing effects, and sometimes in exceedingly bad taste. The fact we wish to emphasize, however, was apparent, namely that American women are not only fond of jewelry but they wear it.

* * * * *

WITH the empire style of dress which at present prevails, and which was, furthermore, a model for many of the toilets at the late ball, came into fashion the heart brooch. This brooch is merely an outline composed of a row of diamonds, sapphires, rubies or pearls, with a pin across the back. Sometimes two outline hearts, in contrasting colors, are interlaced.

* * * * *

DIANA's emblem, the crescent, is a favorite both for wearing in the hair or inserting among the diaphanous folds of a tulle ball dress. There are crescents in brilliants and crescents in diamonds. A jewel *par excellence* is a crescent showing a row of sapphires in the center.

* * * * *

FOUR crescents interlaced present a charming design, whether the horns be turned inwards or outwards. In this form sapphires and diamonds may be combined; also in a double crescent interlocked, so as to make a ring.

* * * * *

DECOLLETEE gowns call for necklaces, which, by-the-by, have never been more fashionable than at the present time. Even the *riviere* becomes a secondary consequence in comparison, and is used

as a trimming for the bodice rather than as a decoration for the throat.

* * * * *

PEARL necklaces are exceedingly fashionable. A form of necklace largely patronized consists of strands of fine pearls. Again, the necklace is made of pearls in gold setting and forming a floral design in front with a pearl pendant dropping therefrom. A tasteful necklace seen was of tiny pearls with a pearl pendant in the shape of a pansy.

* * * * *

NUMBERED with pleasing gold necklaces is one consisting of a delicate chain of gold, holding small flowers enameled as nearly as possible in the coloring of the natural blooms.

* * * * *

TO WEAR across a low bodice from the shoulder to the waist, come branches or long sprays of diamond flowers. For this same purpose a diamond *riviere* with pendants falling like dew drops at intervals, is very effective.

* * * * *

A SINGULARLY effective ornament is in the form of a spray of flowers, the stem and leaves being all alike encrusted with the finest brilliants, and the flower itself, which is set upon a spring, oscillating lightly on a stem and reflecting every ray of brightness in a dazzling manner.

* * * * *

JEWELED ornaments for the hair have gained a decided importance and there was, perhaps, no one other ornament so largely represented at the late inaugural ball as these decorations.

* * * * *

THE FORMS simulated by the hairpins and combs are legion, and it is not always an easy matter to decide whether the article shall be classed as the former or latter, especially when the decorative top is mounted on three prongs.

* * * * *

THERE are combs of all sorts, some with a few long prongs and some with fine teeth for sticking sideways into the hair. All are surmounted with decorative tops of one kind or another. Most of these tops are curved and some are beautifully enameled. There are small combs that come in sets of three, each being decorated with different stones mounted on a narrow band of gold.

* * * * *

THERE are some beautiful tortoise shell pins with flat gold heads pierced in arabesques in a florid style. Other pins come in a more simple style, such as balls, spherical and oval.

* * * * *

A LARGE Parisian novelty consists of two-pronged pins the tops of which are ornamented with biscuit colored enamel.

* * * * *

THE CATOGAN style of coiffure, recently introduced, calls for decorative slides. Some seen and designed especially for this style

of hair-dressing, were in tortoise shell, gold and enamel. These slides are held in place on the hair by metal teeth or points fixed inside.

* * * * * *

MANY of the jewel-topped hairpins have one pin twisted and the other straight to insure the ornaments keeping a firm hold in the hair. Crests and coronets of filigree gold, which are exceedingly popular designs for brooches, are also employed for hairpin tops.

* * * * * *

THE bodkin pins, while not so easy to adjust as those with two prongs, cost usually less and consequently remain in demand. Some of these pins are mounted with enameled flowers.

* * * * * *

MOTHS and butterflies reproduced in different sorts of enamel with outlines of gold, also gem-set ones, figure largely in ornaments for the hair, as well as in brooches and scarf pins. Not a few of the enameled butterflies and other insects are copied from nature with the greatest care, size as well as color and texture being considered. Where points of peculiar brilliancy are required precious stones are employed.

* * * * * *

PARISIAN jewelers, who have a knack of producing exceedingly tasteful ornaments at small expense, have made some very attractive designs in hair ornaments with gilding, paste and brilliants. In this connection it may be told that our own manufacturers are using semi-precious stones with good effect.

* * * * * *

QUITE new are jet ornaments in form of small coronets or crowns designed especially to be worn with high coiffures. There are the bands for going round the head with one large radiated star in front and also smaller ones set around at equal distances. Miniature high combs in Spanish patterns are to be seen, and there are also long hat and bonnet pins with large faceted jet heads.

* * * * * *

A PEN and ink sketch is inadequate for the description of the brooches now in the market. Their forms are varied and many.

* * * * * *

THE LIST of enameled floral brooches is a long one. There are three kinds of enamel employed in these brooches, *i. e.*: the bright opaque, the dull opaque and the transparent. Some blossoms look best in one, some in another.

* * * * * *

FOUR-LEAVED clovers still find favor as designs, not only for brooches, but as pendants to gold chain bracelets. These come in both gold and enamel.

* * * * * *

PERHAPS the flowers most frequently simulated in brooches and scarf pins are violets, single and double. The ampler forms of orchid, the wild rose, the daisy and carnation, are other favorites. General Boulanger's favorite flower, the pink, which French women have latterly patronized, is another blossom now represented in brooches.

VERY pretty brooches representing Parma violets, have often a diamond dew drop to relieve the monotony of their lavender petals.

* * * * * *

DIADEM and coronet brooches in gold filigree and sparkling with diamonds, are classed among the newer ornaments.

* * * * * *

AMONG late comers in brooches are those of oblong shape with a border of small diamonds encircling an oblong moonstone or cat's-eye.

* * * * * *

THREE horseshoes, each set with different colored stones and interlinked, make an exceedingly effective brooch, as do three crescents, similarly treated.

* * * * * *

NO MORE weddings within the charmed circle of Mr. Ward McAllister's 400 until after Easter, which falls this year on the 21st of April. The nine days intervening between Easter Sunday and the first of May will be prolific in weddings, for the old adage that "The May bride is sure to be unlucky" has rendered marriage in the month of May among the ultra fashionables almost as undesirable as a wedding in Lent.

* * * * * *

FORTUNATELY, for our jewelers the marriageable girls of the 400 do not entirely control the wedding bells for that very large majority who are not restrained by the edicts of the limited circle referred to, or governed by worn-out adages and omens. That there will be weddings throughout the month of May as well as during June, we have no doubt and will proceed, therefore, with some items gleaned for the special benefit of prospective brides.

* * * * * *

THE plain gold ring now, as for many years past, remains the correct style in wedding rings. The engagement ring permits of the gratification of individual taste, and is usually set with the gem most admired by the fair *fiancée*.

* * * * * *

AT A wedding in high life which occurred in New York just before lent, chatelaine watches were presented by the bridegroom to the bridesmaids. The watches were in blue enamel suspended from a blue enamel brooch having for its center a monogram in small diamonds. The side chains were also in blue enamel.

* * * * * *

APROPOS of chatelaine watches is a new-comer in the way of a combination bracelet, watch chatelaine and brooch. The top of the chatelaine is provided with a strong pin and catch and may be detached from the chatelaine and worn as a simple brooch. The watch can also be detached from the chatelaine and placed in the bracelet.

* * * * * *

BRIDESMAIDS officiating at weddings occurring directly after Lent, will be, in some cases at least, the recipients of souvenirs that bear the impress of Easter, as for instance, prayer books in silver bind-

ings, flower brooches representing a lily or passion flower, bird brooches, and the like.



ARTICLES in leather with silver mountings remain as popular as ever, and quite a number of new things are out in the way of covers to prayer books for the Easter trade. There are also many pretty things in the way of wedding presents of leather.



WHITE stamped leather presenting an appearance not unlike ivory, is just the thing for both Easter prayer books and wedding gifts.



LEATHER stamped with a design like Venetian lace and of a light brown tone, has been made up in many quaint devices, including photograph frames and card cases.



BLOTTING books, stationery cabinets, portfolios and similar objects of recent introduction, are covered with what is called "daisy leather," the ground work of which is electric blue in color and closely covered with stalkless white daises.



THE SILVER is always a feature of wedding presents. Where the bride and groom belong to families of comparative wealth a whole service, as a rule, appears, breakfast, dinner and tea complete. This, naturally, is the offering of one or more of the family. In addition are many odd articles that may properly be presented by any guest or friend.



A MISTAKEN notion prevails in the minds of many persons that a wedding present means a large expenditure of money. In point of fact, there are many modest offerings reposing in our leading stores worthy to hold a place of honor with the gifts of wealthy men and women. The comparatively small sum of five dollars will buy at Tiffany's, at Gorham's, at Whiting's and other trustworthy houses, one of the many odd pieces in silver so useful and at the same time ornamental. For instance, there are pickle forks, berry spoons, napkin rings, grape scissors, sugar sifters and the like, marked at or about the sum mentioned.



A SUGAR sifter introduced for the Easter trade comes in the form of a silver egg, etched with appropriate inscription. The small end of the egg is covered with a perforated top.



THE rumors afloat concerning a ruby trust that is to control the workings of the mines of Burmah, will doubtless cause the possessors of fine rubies to value their gems all the more highly, though there is no certainty that it will effect the prices of these already rare and costly stones. Connoisseurs now, as for many years past, highly prize fine and flawless specimens of both rubies and emeralds.



THE announcement made last spring of a diamond trust likely to control the South African mines did not prevent the wearing of dia-

monds both at home and abroad in great profusion. Fashionable as diamonds were last season these gems are, if possible, to be still more *en evidence* this year.



NUMBERED with diamond brooches seen during the past month was one representing a pheasant, and another a swallow in the act of flying.



A NEW design in rings is an open one the ends of which are set with sapphires and hold between them a fine diamond and ruby set diagonally. Another fine ring consists of three gold wires, spreading apart on top far enough to admit of the diagonal placing of a fine pearl and two diamonds.



FINE diamonds, as a rule, show to best advantage in the simplest possible setting and when each stone manifestly serves a given purpose. For instance, a *riviere* of single diamonds, a star in the hair or to fasten a fichu of lace on the dress, to satisfy the eye and give a sense of splendor or utility combined. On the other hand, the same number of gems scattered over the person without serving any apparent object, appear ostentatious and unmeaning.



APROPOS of the above, it may be well to remark that many of the most valuable diamonds seen at the late Inaugural ball were in the plainest of settings, and that stars, Maltese crosses and single rows were in sufficient number to justify the belief that these will be in fashion for some time to come.



THE horseshoe remains a favorite form for brooches.



A UNIQUE bracelet is one formed of a single gold hoop, mounted with a fine Brazilian diamond cluster.



A BRACELET appealing to fair equestrians is one known as the horseshoe and crop bracelet. In this the crop forms a bracelet with overlapping ends, held together with a diamond horseshoe.



ONE swallow does not make a summer, but three gem-set swallows on golden twig form an exceedingly attractive brooch.



IN ALL gold brooches are seen some exceedingly pleasing effects in twisted and knotted wire. There are also some very pretty gold curb chain brooches, both with and without gem settings.



GOLD curb jewelry is by no means confined to brooches; a popular form of it is in bracelets, both stiff and flexible. Included among novelties in this direction are platinum and gold bracelets.



LADIES' rings are beautiful and varied beyond precedent. Hence

the impossibility of anything like a satisfactory description. There are fine diamond half-hoop rings, there are three and two-part rings, there are solitaires, clusters and Marquise rings, in which diamonds, rubies, emeralds, sapphires, opals, moonstones, pearls and fine garnets all take a part.

* * * * *

SLEEVE links continue to be much worn by men. Gold dumb-bell links find patrons, as do the whip and horseshoe links. Ladies, as a rule, prefer the sleeve buttons which come in small and medium sizes.

* * * * *

THE prettiest "89" jewelry seen was made of gold or silverware, the "89" being this wire so knotted as to form the figures 8 and 9 interlinked. This style of "89" jewelry is represented in bracelets, sleeve links, brooches and studs.

* * * * *

THE demand for initial jewelry which never entirely ceases, is, at the present moment, unusually active. In the way of brooches have appeared fine gold and pearl ones. In these, graduated pearls are set in form of a crescent, the initial being formed of gold wire and placed in the hollow of the crescent. In this connection it may be well to mention the pearl and gold leaf brooch with diamond center, which resembles the one just described, except that a leaf takes the place of the initial.

* * * * *

THERE are some quite pretty initial bracelets, in instance of which may be cited one consisting of a double gold band decorated on top with a floral pattern traced in tiny pearls, and with initials in the center of the floral design.

* * * * *

APROPOS of Easter are brooches simulating a merry thought bone, on one branch of which is a chicken just hatched and a broken egg shell, the chicken and shell being finished in enamel.

* * * * *

A LATE novelty which embraces a useful invention comes in form of a charm that may be worn as a pendant to a Queen chain or chatelaine, or may be hung in a compartment of one's desk. It is a letter balance and stamp box, and, as the name suggests, it weighs letters, tells postage and holds the stamps.

* * * * *

THE Swiss cuckoo clocks, already familiar in most sections of the country, are out for the season of 1889, with the addition of a weather barometer. This barometer, which is introduced directly below the cuckoo and above the dial, is in the form of a little house, in the double doors of which stand two finely modelled figures—a man and woman—peasants. The man steps out if the weather is to be wet, and the woman if the weather is to be fine.

* * * * *

THAT exceedingly useful and prosaic article, the thimble, has of late years been the object of decorations which render it a thing of beauty. Not only have we thimbles with richly chased flanges, but there are flanges in *repoussé* work enriched with tiny diamonds and other gems.

GARTER clasps are another article that has been of late the object of elaborate ornamentation. Many of these clasps are of gold, with a monogram etched thereon or traced with jewels. Silver garter clasps are the popular sort. Most women wear them now that very pretty ones may be bought at from three to five dollars per pair.

* * * * *

MENUS ought to be included with stationery in the jeweler's stock. There is a fancy for menus in silver filigree supports. These supports, when not desired for the menus, do duty for photographs.

* * * * *

DEAD silver filigree designs on a background of bright shining metal, is both effective and popular. Toilet and writing table accessories composed of it are fashionable as wedding presents.

* * * * *

PARASOLS which, along with umbrellas, have become important features in the jeweler's stock, deserve a word or two in the way of description. The new parasols have handles of natural woods, including holly, bamboo, cherry or ebony. These handles terminate sometimes with curiously twisted hoops, or large hooks or knobs, or else they are quaintly carved or tipped with silver or gold.

* * * * *

PARASOL handles are quite long this season. Those for general use, also coaching parasols, have sticks that measure fourteen inches beyond the edge of the silk cover when closed. The Directoire parasols have much longer handles, extending 18 inches beyond the cover.

* * * * *

WHILE silver handles or handles decorated with silver prevail, there are also parasols with chased gold handles.

ELSIE BEE.

Advice to Watchmakers' Apprentices

BY A MAN WHO HAS SPENT TWENTY YEARS AT THE BENCH.



DIAMOND lap formed by forcing diamond dust into a copper disc makes a splendid tool to damascen steel wheels. I will describe the process of making and then go on to show how to arrange the train of pulleys to drive the cutter, and at the same time revolve the lathe spindle slowly. Cut out a disc of copper $\frac{1}{16}$ of an inch thick and $\frac{1}{2}$ of an inch in diameter; next prepare some fine diamond dust and apply it to the face of the copper disc just described. Lay the copper disc on a flat, smooth steel stake; then place a piece of wide mainspring on top of the lap where the diamond dust is spread and strike the mainspring with a small hammer, as shown in fig. 1, where *B* represents the steel stake, *a* the copper lap, and *A* the hammer. The steel mainspring *b* being so much harder than the copper serves by the force of the blows from the hammer to press the particles of diamond into the copper. After the copper lap is sufficiently charged with diamond dust, it is mounted on the arbor shown at fig. 1, in February (1889) number of this journal. I will now try and be as brief as possible in my explanation of the several parts necessary for the operation. In the cut at fig. 2, the general arrangement of the pulleys for producing the compound motions required is shown. In order to turn the spindle of the lathe very slowly we must place on the axle of the foot wheel a very small pulley, *d*. A band is passed from this pulley to transfer

pulleys *G*, placed at the edge of the bench, and from these transfer pulleys to the lathe spindle *D*. I have made no effort to show supports for the various wheels and pulleys, but have merely shown a circle to represent a wheel or pulley. As for instance the circle at *F* represents the drawing wheel and the small circle at *d* the little pulley connected by a proper band, *i*, to the transfer pulleys *G*. All the circles representing wheels, etc., are in three relative positions above and below the bench *C*. The circles at *E* are to represent the wheels on the counter shaft and the circles at *H* a sub or extra countershaft to increase the velocity of the corundum cutter or diamond lap. The transfer pulleys at *G* are temporarily secured to the edge of the bench. A cheap and easy method of getting up such pulley is to take a piece of inch board of some hard wood like black walnut, 3 inches long, and shape it as shown in diagram *G** which is an edge view seen in the direction of the arrow *C*, fig. 2. This block is sawn into and a recess made to receive the two loose pulleys *f f*. Pieces of hard wood will answer for these pulleys. A wire, *g*, will serve for the pulleys to turn on. The object of placing the pulley *f f* at the edge of the bench is to avoid cutting through it for the bands *i i* to pass. If the pulley *d* on the driving wheel is $\frac{3}{4}$ of an inch and the pulley on the lathe $2\frac{1}{4}$ in diameter, the lathe spindle will turn once for 3 times of the driving wheel, which is about the right speed. We will now briefly consider the results we wish to obtain and then arrange our several parts to produce these results. The damaskeened wheel when finished has generally had two applications of the cutter to its face, as shown at diagram *L***. How this is accomplished is shown in fig. 3, where *D* represents a chuck in the lathe spindle and

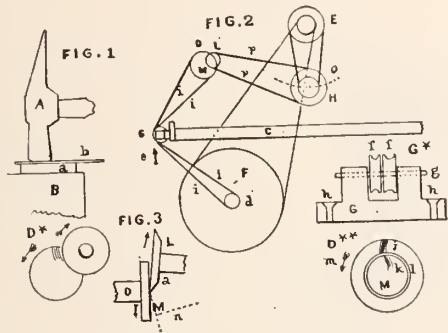

M a wheel to be damaskeened. The diamond lap or corundum wheel is shown at *a* attached to its arbor *L*, which runs in the **U** shape (supposed) described in February number of THE CIRCULAR. The lap *a* is set so the edge just touches the steel wheel *M*, as shown in diagram *D**. Now the rapid motion of the diamond lap cuts away the steel, leaving bright streaks from the diamond or corundum particles in curves, but as the wheel *M* revolves slowly these fine, bright scratches or grooves seem to spread around the surface of the wheel. Some steel wheels have two such markings, as shown at *J k*, diagram *D***. Generally between such separate markings of the lap a concave groove is turned and polished. The best way to accomplish this is to turn and polish the groove before the damaskeening is done. This is also the case with the teeth when they are beveled and polished on the edge. We will take this matter up subsequently; for the present we will confine ourselves to the damaskeening. The reader will please remember that the **U** shaped piece was provided with a joint in the pin which went into the tool rest holder which permitted us to set the lap in any relative position to the wheel *M*, so that we could allow the lathe arbor to turn in either direction, as for instance when cutting so as to produce lines like those shown at *J* diagram *D***, the wheel *M* turns in the direction of the arrow *m*, and when cutting the lines at *K* the wheel turns the opposite direction and the cutting disc is applied as shown at the dotted lines *n*, fig. 3. This is all very easily done by arranging the sub-countershaft *H* so that the band from *H* to the pulley on the cutter spindle can be readily tightened to suit any position of the cutter, as for instance *L* to *n*. In making the sub-countershaft *H* it is not necessary to have any shaft; two wood pulleys are joined together and turning

on a pin will answer every purpose, as it is only occasionally such a device is used at best. Take for instance two nicely made pulleys of wood, one 4 inches in diameter, and the other $1\frac{1}{2}$ inches, glue these together and place a plate of brass $\frac{1}{16}$ of an inch thick on each side, and broach out the holes in these plates so the combined pulleys run true. Let these pulleys turn on a pin and swing back and forth on the line *o* in such a manner that we can tighten the band *P*, and with a set screw fasten the pulley *H* in the position to properly drive *L*. The damaskeening should only be attempted on hardened wheels.

The Jewelers' Security Alliance

President, DAVID C. DODD, JR.

First Vice-President, AUGUSTUS K. SLOAN.....Of Carter, Sloan & Co.
 Second Vice-President, HENRY HAYES.....Of Wheeler, Parsons & Hayes.
 Third Vice-President, DAVID UNTERMAYER.....Of Keller & Untermeyer.
 Treasurer, W. C. KIMBALL.....Of Strange & Brother.
 Secretary, GEO. H. HODENPYL.....Of Hodenpyl & Sons.

EXECUTIVE COMMITTEE.

J. B. BOWDEN, Chairman.....Of J. B. Bowden & Co.
 C. G. ALFORD.....Of C. G. Alford & Co.
 N. H. WHITE.....Of N. H. White.
 CHAS. G. LEWIS.....Of Randel, Baremore & Billings.
 F. KROEBER.....Of F. Kroeber Clock Co.
 SILAS STUART.....Of Silas Stuart.

EXAMINING FINANCE COMMITTEE.

EDWARD SMITH.....Of Smith & Knapp.
 A. JORALEMON.....Of A. Joralemon & Co.

For further information, Application Blanks for Membership, By-Laws, etc., Address
 P. O. Box 3277. 170 Broadway, New York

At the regular monthly meeting of the Executive Committee, held at the Alliance office on the 8th inst., there were present David C. Dodd, Jr., President, J. B. Bowden, Chairman, Messrs. Kroeber Stuart and Secretary Hodenpyl.

The following were admitted: Chas. J. Giering, 65 North street, Middletown, N. Y.; R. Harris & Co., 108 E. Fayette street, Baltimore, Md.; George H. Elson, 9 Park street, Boston, Mass.; Baker & Co., 408 N. J. R. R. avenue, Newark, N. J.; Henry Yoste, 101 Washington street, Vicksburg, Miss.; A. D. Selover, 121 Mulberry street, Newark, N. J.; Junius R. Watts & Co., 57 Whitehall street, Atlanta, Ga.; Alex. J. Hubbard, 4 S. Charles street, Baltimore, Md.; Gurney Bros., 122 Main cor. School streets, Brockton, Mass.; F. G. Thearle, Jr., & Co., 301, 303 63d street, Englewood, Ill.; J. W. Perry & Son, 90 Lisbon street, Lewiston, Me.; Moores & Winder, 351 Broadway, Troy, N. Y.

The Case Screws.



THE OLDEST method of fastening the movement is that with points at XII, which style is often still seen in English detached levers, although other methods are also employed.

The fastening of the movement in Swiss watches is generally effected by three pins on the plate rim and by a casing or dog screw. In most watches only one locking screw is found; two would be better, however, because in case the head of one should burst off, the other would offer sufficient resistance against the dropping out of the movement. The heads of the locking screws will fly off when the watch falls accidentally; the case will often be indented thereby, the balance pivots break, or the crystals break; the movement will generally be injured least, as the crystal breaks the blow.

The location of the case screws underneath the dial, as shown in fig. 1, offers no advantage; it is only inconvenient, because every time the movement is taken out, the dial together with the hands must be taken off. This arrangement is sometimes found in fine

Swiss stem winders, in which two screws are located at proper distances apart; when fastening the movement, they are turned to the left and operate in the usual manner. Besides this, two pins are generally located at the edge of the plate; one pin seizes under the rim, while the other prevents the turning of the movement.

In very rare cases have fine Swiss watches, in place of the ordi-

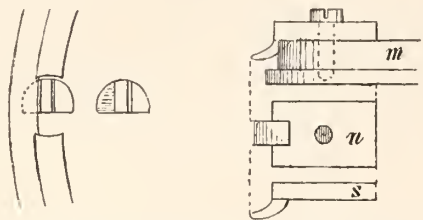

nary case screw, a screwed-on steel stud, fig. 2, which braces upon the center part of the case. Fig. 2 gives three views, on an enlarged scale, of this arrangement: *s* is the side view at *m*; it is screwed upon the plate, and *n* is the lower view.—F., in *Allg. Journal d. Uhrmacherkunst*.

Is the Stopwork Indispensable?

THE QUESTION whether the Maltese cross or stopwork in medium and long grade watches is indispensable or not was some time ago debated in a meeting of watchmakers in Germany. Those in favor of dispensing with it proposed a number of other devices, among which is the brace. One of them published his views on the matter subsequently in the *Deutsche Uhrmacher Zeitung*, from which we translate the following:

I am not whatever opposed to the stopwork; on the contrary, I consider it to be one of the best and most secure devices—if well executed and hardened, and the square of the spring arbor upon which the stop sits is sufficiently long and well conditioned. Every repairer, however, knows the condition of the stopwork in the ordinary cheap watches. . . . It is an ordinary occurrence that already in the first four weeks the man who recently bought a cheap watch from you will come back to the shop with his watch overwound, and from that time forward misconfidence against his timekeeper and yourself is fully established. Frequently, also, does it happen that after the mainspring is broken the owner also ruins the stopwork by winding, when he is a sort of a Jack-at-all-trades and tries to remedy the evil himself.

Some repairers urge that when an ordinary brace stop is used, more springs break than by the use of a stopwork. I cannot say that this is my experience, although I have been a repairer for a number of years. If ever it should be true that the breakage of springs is greater by 10 per cent., surely watchmakers cannot call this a great misfortune! Nor does the assertion hold good that the small end of a spring (the brace) forms a separate spring power, as this force lasts barely one minute.

Another advantage of the simple brace stop in the interior of the barrel is that this is rendered much more secure, as the cover does not require to be turned down and out, and the spring arbor can at its lower end be made with a nice and long pivot. All the repairers know how terribly shaky some barrels are in consequence of the pivot hole being too thin in the barrel cover, and also in this particular a decided defect would be remedied. The time which the workman spends upon the repairing or re-making of the stopwork may, by the employment of the simple brace, be spent to a far better purpose upon the other parts of the watch. . . . For better grade watches, which have from the start been constructed with more care, and on which more time is spent in repairing, they may be employed profitably.

Three methods are known to me for using the brace as a stop,

The first consists in riveting a small piece of watch spring to the end of the spring and of beveling its free side a little; by the second, the end of the spring is bent into a small hook, in which is laid a small piece of spring with beveled ends; by the third, the spring is bent outward at a length of from 5 to 10 millimeters near the end, which must be done, however, while the spring is red hot, so that it will not break in bending. The diameter of the spring core can, in general, be taken as the length of the brace. The latter method is the simplest and easiest, and I have successfully employed it for a number of years. The hook in the barrel is unnecessary, and a very small pin slightly projecting within is all that is required; even this fear is not necessary; simply raise a burr with a sharp graver on the inner side of the barrel.

In conclusion the writer solicits the opinion of other watchmakers on this question.

Copyrighted 1888 by Charles A. Bucklin.

Mechanical Ocular Defects.

Their Nature, Causes, Correction and Relations to Functional Nervous Diseases.

EDITED BY C. A. BUCKLIN, A. M., M. D., NEW YORK.

[The aim of the author is to produce a clear and thoroughly practical course of instruction on the subject of "mechanical ocular defects," which is entirely void of useless technicalities and within the easy comprehension of every thinking student, without his having had any previous technical or mathematical education.]

LIGHT AND LENSES.



LIGHT IS SOMETHING beyond our comprehension, but to understand our subject we must have a conception of its nature, however rude it may be. Light must be regarded as an ether which pervades the universe, having the sun and all forms of artificial illumination as its source of origin; from these sources it radiates in wave-like form, traveling at a velocity expressed in round numbers as 186,000 miles a second. The nearest representation of the motion of light is the waves caused by throwing a stone into a smooth surface of water. Upon water the wave-like motion is confined to one plane, the surface of the water, while the wave-like motion of light in air must be in every possible plane. Light coming in contact with objects in space is reflected from these objects, and through this means, assisted by our optical apparatus (the eye) and nervous system, we become acquainted with the nature and form of objects which are not in direct contact with us. This reflected vibrating light wave is the telegraphic connection between the universe and our eye. The eye is the telegraphic instrument which receives and gives such form to the communication that it may be appreciated by our sense perception. Without light the impression of distant objects could never traverse space and arrive at our eye for recognition. Without the eye we would be as helpless as the telegraph operator would be without instruments in attempting to decipher dispatches which he knew were passing over the wires. Without a nervous system and intellect we would be as helpless as the country telegraph office which has wires and instruments but no operator. Sun light and electric light are a combination of violet, indigo, blue, green, yellow, orange and red light, which, when mixed together, form white light.

When all of these lights are equally reflected from a surface the

object appears white; when none of these lights are reflected, but are all absorbed, the object appears black, because there is an absence of light coming from it. If any one of the spectral rays are reflected from an object, the color of the ray reflected is the color of the object. Any combination of colors may be reflected from a surface, thus giving rise to all possible shades of color.

Lamp or gas light does not contain all the spectral colors, consequently when buyers wish to examine the color of goods by gas light they are foiled, because all colors are not there to be reflected, even should the quality of the goods be such that they would be reflected if present.

It is thus seen how the impression of color is communicated to the eye. The mechanism of its perception by the brain is a more complicated subject and not in order under this head.

A finely polished plate of glass with certain conditions of light may allow the light to pass through it so perfectly and reflect so little light that an individual is entirely deceived. He supposes the plate of glass is open space. The mistaken impression is only corrected when he attempts to plunge his head through what he supposes to be vacant space. The crash which follows makes him aware of the deception which the lack of *reflected* light has made him the victim of. *The brain* always locates an object in a direct line with the direction of the ray of light as it enters the eye. It makes no difference how many times the direction of light coming from an object has been changed, the direction of the ray as it enters the eye decides the location of the apparent position of the object.

There is a decided similarity in the deflection of projectiles in general by reflection and deflection, and the deflection of light by reflection and refraction. Thus a billiard ball *fairly* struck takes and leaves the cushion at equal angles. Light rays striking a polished surface are reflected from the surface at the same angle at which they struck the surface.

A bullet striking a plane surface at exactly *right* angles will pass through without deflection. Rays of light striking a transparent medium in the same manner will pass through without deflection or refraction.

Refraction of light on plane surfaces.

To illustrate how transparent media with plane surfaces act upon rays of light which enter the medium at an angle, let us examine the effect produced when the rays of light enter a surface of water obliquely. We take one fixed point from which to measure the effects upon the light. This point is a plumb line which reaches from above the water to the bottom of the same. This line is called the perpendicular; from it the angle at which the light enters the water is measured; also from this perpendicular the angle formed by the refracted ray in the water is measured. The entering ray of light is called the incident ray, and the angle it forms with the perpendicular is called the "*angle of incidence.*" The ray of light after passing from its source into a rarer or denser medium is called the refracted ray, and the angle it forms with the perpendicular is called the "*angle of refraction.*" The proportion existing between the angle of incidence and the angle of refraction is called the index of refraction. The angle formed with the perpendicular by the passage of light at a given angle into distilled water of a given temperature is the unite by which the refractive indices of all other refracting media are measured. Glass, pebble and diamond have successively increasing higher refractive indices.

The law is as follows: A ray of light passing from a rare medium obliquely into a denser one will be bent toward the perpendicular. In all cases the amount of deflection will be greater in proportion as the refractive index of the substance is high. Light in passing from a dense into a rare medium will be deflected from the perpendicular as it enters the rare medium.

These laws are all beautifully illustrated by some of the optical deceptions most of us have observed during our boyhood.

Light strikes an oar in the water and is reflected from the oar *obliquely to our eye.* Upon leaving the water and entering the air,

the ray is bent from the perpendicular which would pierce the water at this point. We always judge of the position of an object by the direction of the rays which enter our eye. The light which comes from the part of the oar out of the water comes directly to our eye without refraction. The light which comes to us from the part of the oar which is in the water comes to us at a different angle. It is clearly seen that if the light as it emerges from the water is bent from the perpendicular, that portion of the oar which is in the water will appear to be bent upward. Rays of light which are reflected to us obliquely from a fish in the water, for the same reason cause the fish to appear in a different position than he really is, and if we strike at him with a spear in the line of the light as it enters our eye we certainly will strike clear of the fish. As boys we learned to strike directly over the fish or to strike where our judgment, gained by experience, taught us to believe the fish was. We knew that under these circumstances our eyes were the victim of an optical deception.

These laws are again most beautifully illustrated by placing a coin in a tea cup, and placing our eyes so that the edge of the cup just hides the coin from our view. If water is now slowly added the rays of light coming from the water into the air will be bent away from the perpendicular. This bending of the rays will cause them to fall on a level with our eyes and the coin which was hidden appears in sight, but quite as rapidly disappears if the water is slowly removed by some suction apparatus.

Plane surfaces only refract rays of light which enter obliquely. If we wish to refract light in any desired direction we must pass it through transparent media, the surfaces of which are not plane but curved. The entire art of lens construction consists of giving properly curved surfaces to transparent media which will produce required optical effects.

Correspondence from readers of THE CIRCULAR regarding persons who are blind will receive prompt attention. To determine whether a blind person can regain his sight it is necessary to answer the following questions: Is there a milky or gray spot seen deep in the pupil? Have the eyes ever been injured, painful or severely inflamed? At how many feet can the light of a candle be seen in a dark room with the right eye? With the left eye? At five feet can the candle be seen when held above, below, to the right and to the left of the right eye? The left eye? The eye should not be allowed to follow the candle. With the person's back to the light of the window, at how many feet or inches can the right eye count figures? The left eye? With these questions carefully answered it can be quite positively determined whether a blind person can have his sight restored or not.

Practical School of Optics.—I call the attention of my readers to the fact that this school offers the only opportunity in the United States for obtaining thoroughly practical, systematic instruction in optics. Optics cannot be taught in classes too large to prevent each student from receiving personal instruction. This subject can be more thoroughly taught in two weeks through object teaching than in the same number of years by any other method.

The following students have completed the course of instruction given in March: William O. Amann, Sidney, Ohio; John H. Leyson, Butte City, Montana; Charles C. Cocklin, Phillipsburgh, N. J.; Mitchell H. Woodhull, Riverhead, N. Y.; Gerson Marcus, New York; Arthur W. Johnson, Bradford, Mass.; Geo. B. Lyon, Hammondsport, N. Y.; Henry E. Vogler, Winston, N. C.

A class will probably form during the last week of April. The time will be communicated by mail to those applying for a place in the class.

NEW USE FOR ALUMINUM.—Aluminum is coming into use as a material for dental plates. It is nearly as light as rubber, but little more than one-eighth the weight of gold; has neither odor nor taste; is not affected by the elements of food or the secretions of the mouth, and costs, bulk for bulk, about one-sixth the present price of silver.



[FROM OUR SPECIAL CORRESPONDENT.]

THE LOUIS QUINZE STYLE IN SILVERWARE.—WORK OF THE COMMISSION FOR POPULARIZING JEWELRY.—MINIATURE WATCHES.—BALLS AND BANQUETS IN *BON PARIS*.

PARIS, March 5, 1889.

The Louis Quinze style is almost the only one at present used in all the Parisian silverware. Although the revival of this fashion took place some time ago, the public, instead of getting tired of it, seems to take to it more and more. The reason of this unusual attachment of the French people to one particular set of forms is the inexhaustible variety of ornament which that elegant style admits of. Besides, the capriciousness of the lines and shapes, which are characteristic of it, cannot fail to charm the fancy of our fair sex, to the dictates of which (in matters of taste) the male portion of our country is always ready to lend a most obedient ear.

Our silversmiths, engaged in copying the patterns invented during the frivolous reign of Louis le Bienaimé, do not all follow the same course. Among those who have become acquainted with nearly all the details of the pieces scattered in well-known collections, and with the drawings and sketches made by Juste-Aurèle Meissonnier and Pierre Germain, some simply try to imitate to a nicety what has been so prettily done, while others endeavor to develop further the ideas of those delicate models. Now, I do not believe that the Baron Jerome Pichon or M. Paul Eudel, or, in fact, any collector, would allow even an intimate friend to take so close an inspection of their ancient ewers, candlesticks, soup tureens, vegetable dishes, powder boxes, etc., that the designs could be exactly reproduced. The same can be said concerning the great variety of works bearing the mark of François Thomas Germain, which belong to the King of Portugal, and of the surtouts which are the property of the Emperor of Russia, not to speak of the Grand Duke Alexis' toilet pieces. In such unfavorable conditions copies are bound to be very imperfect, and, therefore, any attempt in that line ought to be abandoned. J. A. Meissonnier's works, including more than 1,200 drawings, offer many models of candelabra, cruet stands, salt cellars, mirror frames, etc., well worthy of being reproduced; but the author, a friend of the celebrated François Boucher, was himself appointed painter, sculptor, architect and designer to the King, and, although he may have sketched and inspired a large number of the loveliest silver pieces made during the best period of Louis XV.'s reign, he was not a silversmith. His rocaille style can be considered as the boldest and most unique of all. His wonderful winding and twisting of shell fragments entwined with sprigs of roses and other flowers, the original introduction of vegetables or fishes which, owing to a happy arrangement, look really graceful on covers of dishes, and, in another line, the pretty cherubs peeping out of clouds on high crosses, chandeliers and incense burners, are models which deserve to be studied. But the overflowing richness of the ornaments, so beautiful on paper, might appear heavy and perhaps too bold in the execution. All that would have to be regulated. Pierre Germain's *Elements d'Orfèvrerie*, which can be consulted at the Bibliothèque Nationale, is far more practical. One can see at a glance that all the sketches and drawings it contains are from the hand of a silversmith. He applied himself above all to the correct proportion of all the different parts of his works so as not to transgress the limits of elegant originality, besides never losing sight of absolute fitness. As a conclusion to this paragraph, I must be contented with adding that our wants, habits and ideas being somewhat different from those of our forefathers, it is not altogether advisable that we should copy them exactly even in the most beautiful things they have done.

The "Commission de la Mode," appointed by the Jewelers' Chambre Syndicale, to stir the public taste and call to life again the fashion of wearing jewels, have given a very favorable account of the results obtained during the last months of 1888. They seem absolutely certain that the decided improvement of business in November and December was partly due to their exertions. I am willing to admit that they may have done something towards it, but, as it is impossible to ascertain exactly to what extent they have succeeded in their laudable move, I am afraid they are a prey to a delusion. Some very sparkling articles have been published on jewels in the periodicals bought over to the cause, and the authors of these expensive lauds on diadems, necklaces, brooches, etc., have, no doubt, tried their very best to dazzle their fair readers. Yet, I think that sometimes their tone is too enthusiastic, and the lack of real knowledge of the subject unsufficiently concealed by an accumulation of commonplace similes, associating the beauty of woman with the fascination of gems. Nevertheless, I feel confident that it will by degrees force the attention of French people, so easily attracted by anything which fashionable papers keep on mentioning. If leading dressmakers could be persuaded to bring out no patterns but those which absolutely require the use of jewelry our wishes would be fully realized, but that most important of results is far from attained.

At the Opera the present fashion seems to be to wear jewels in the most out-of-the-way style. Instead of the usual brooch, more or less elaborate, which we were accustomed to see at the top of the corsage, we notice garlands of gems running along it and suddenly branching downwards as though dropping off. Rows of diamonds, alternating with rubies or sapphires, are used as braces to hold the bodice on the shoulders. Lizards or chimeras, worn on the side near the waist, seem ready to dart about at will.

While the mania of having watches hidden in all kinds of articles is still at its height, we may as well acknowledge that if our time can boast of having made the most of this idea, the old saying "*Nil novi sub sole*," can apply to it as well as to many other things believed to be new. In the works of Pierre Woeriot, goldsmith, chaser and designer, of the sixteenth century, we see a watch encased in the bezel of a heavy looking finger ring. I have had the pleasure of seeing the collection of M. Boin-Caburet. It contains a tiny onion watch, the dial of which is covered with a glass raising up in the shape of a half globe. This Lilliputian timekeeper is fixed to the top part of a ring by a circle of brilliants, at once firmly and delicately mounted on silver, the whole of it showing the remarkable workmanship of the last century. Two original pieces of the same period belong to the Poldi-Pezzoli Museum at Milan. One has the shape of a toyish hat in enameled gold, with one side of the brim turned up, a cord and tassels hanging down from it. A watch is encased in front. The other one, called in the catalogue "A Turkish Slipper," has the form of a wooden shoe with the end slightly curled up. It is enameled in deep blue on the top, and in yellow, studded with light blue, underneath, with a pretty course of white round the opening. This original piece parts in the center to disclose a dial.

The annual banquet of the Jewelers' Chambre Syndicale took place at the Grand Hotel on the 23d of February. It might with propriety be considered the silver wedding of that institution, which was established in 1864. M. Boucheron, President, started the series of speeches, followed by Messrs. Duhamel, Falco and Martial Bernard. Then we heard from those of our new ministers who had been able to come. Messrs. Spuller, Raynal and Faye developed the idea that our cabinet was anxious to avoid all irritating discussions, and that its only object would be to help the participants in the Great Exhibition to render it as attractive as possible. M. Rouvier, the head minister, is known to prefer business to political squabbles, therefore we may hope to see, at last, some of our most important claims seriously examined.

The Bijoutiers' ball will take place on the 16th inst., and it is sure

to be a very brilliant one, especially if the jewelers' wives, putting away their unaccountable prejudices, consent to wear the choicest jewels of their husbands' stock, as they should.

The most fashionable tortoise-shell pins here are of simple patterns—such as balls, spherical or oval. Moths and butterflies are reproduced in different sorts of enamel, with outlinings of gold, in almost every variety. Four-leaved shamrocks are still held in much favor, not only for brooches, but also as pendants for the fashionable gold chain bracelet, when they may be in gold or enamel. Combs of all sorts—those with a few long prongs, as well as those with fine teeth for sticking sideways into rolls of hair—are surmounted by curved tops of this enamel. Two-pronged pins with a plating of gold on the curve, either plain or decorated with precious stones, enjoy considerable favor just now, and similar pins ornamented in this way with the new biscuit-colored enamel are among the latest novelties. The heart brooch is one of the simple forms which came into fashion with the Empire style of dress; it is merely an outline composed of a row of diamonds, sapphires, rubies or pearls, with a pin across the back. Sometimes two outline hearts of contrasting colors are interlaced. There are crescents in brilliants, but the jewel par excellence has a row of sapphires in the center. Four crescents interlaced compose a charming design, whether the horns be turned inwards or outwards. In this form sapphires and diamonds are combined together, also in a double crescent interlocked so as to make a ring.

JASEUR.

Free Hand and Mechanical Drawing.

BY EXPERT.



THE art student cannot pay too much attention to the *technic* of painting; to him it is precisely what bowing and fingering is to the violinist. Painting with most people only means drawing in colors: but there is a vast difference, and unless the student early in his career gets to know and appreciate the difference he will never succeed to any eminence in the profession. The artist at best has but limited means at his disposal and to succeed must avail himself of all methods which his ingenuity can suggest. Again, there are a class of people who imagine that painting depends on little recipes and tricks, and these once learned the student only needs to push himself forward and achieve fame. I suppose if I should assert a

man might be the best draughtsman in the world and yet no painter, or even artist, that many of our readers would think that I was talking nonsense; still the statement is absolutely true. If I should say a man was an excellent gymnasium and yet no poet or orator, the statement would be readily accepted; and still the facts are alike in both instances. A man may be taught to delineate form, and express the value of light and shade—yes, even understand the relation of colors and still not be able to express himself properly with the tools and materials an artist has at his disposal, in fact lacks the technical skill to place on the canvas the scene or object he is contemplating. And the great trouble for us is, this technical skill cannot be described by even the artist himself who practised it. It is a method of expression far more subtle than words, and each artist must invent to a great extent his own technic. To say that any artist to paint deer as well as Landseer would have to adopt Landseer's methods or technic would be absurd; because it is possible an artist might paint these animals even better (all things considered) than

the artist just named and do it by an entirely different method. What I want to establish by all this digression from description of methods of manipulating colors, is to convey to the reader that following any artist's methods is not the way to succeed. When studying the works of other artists endeavor to grasp the idea of what the artist wished to express (for a picture is to the eye what words are to the ear) in every detail. Save to yourself what was his idea and what was his methods of expressing graphically this idea. Question yourself in this way and see if the methods adopted were subject to just criticism, and if you could not, if acting under the same circumstances, have seized a more opportune moment for your picture; and also quiz the technical methods. Do this not only with the works of others but with your own productions. Never be satisfied with anything you see how to do better. In the first or dead color painting don't lay the colors on too thick, but use a rather larger brush, spreading the colors quite flat. To illustrate how difficult it is to give written instructions in matters of technic, even the instructions to lay the colors smooth in dead coloring is subject to exception, as as it is not infrequent that the brush marks left in the material of the dead color is made to do service in modifying the effect of subsequent painting. These effects are to be thought of when doing the first painting, and in art as well as in all our walks of life carry the idea through to the end of the action. I do not wish the reader to get the impression that I endorse outlandish and unusual methods as I have seen artists who had a habit of using a pallet knife to produce results which could have been much better accomplished with



a pencil; not but what if I conceived a pallet knife to be the best tool for a given purpose I would use it; no, I would use a spoon or fork if I thought these implements really gave more desirable results. I believe young artists make a mistake in slighting details and neglecting technical matters than in any other direction. They desire to paint a whole view before they are sufficiently disciplined to paint single objects well. I speak of this to induce the student to make studies as well as sketches. Studies can well be divided as follows: Studies of skies, as I suggested recently; trees of various kinds; water effects, particularly water which is transparent showing a pebbly bottom and at the same time reflections; rocks of various kinds; learn to understand the stratification, and also how the action of frost and water disintegrate them. Weeds afford endless variety, both of wayside and water varieties. Learn to paint such things with judgment and discrimination, not as I once saw a picture of apple blossoms in bloom and underneath them full grown summer weeds; and we all know apple blossoms are only seen in early spring. In my last communication the outline of an entire view and directions for dead coloring, and now I have advised the students to make especial efforts in studies of parts. I do not desire the reader to imagine that I am inconsistent in this—I yet advise the attempt of entire compositions, and by compositions I mean complete pictures, early in an artist's career. The work and practice afforded by careful studies should be carried on simultaneously with compositions of whole scenes if the artist is devoting himself to landscape work. The benefit of a careful study of a rock or tree can be made of immense advantage in painting an entire landscape. The truthfulness of our portion of a painting may make amends for cruelty in three-fourths of the surface of a canvass. It is not in all cases necessary that locality of our study should be the same as the picture in which we introduce the pictorial ideas we acquired by our study.

To illustrate, suppose we were out on a sketching tour, and found a view which struck us as favorable; we make a general sketch of the scene, even dead color our picture on the canvas we are to ultimately finish our picture on, we find on returning to our study that we can introduce in some portion of our picture, one of our carefully made studies and much improve the whole effect. These studies are best made on wood panels, carefully painted over with two or three coats of white lead and oil on both sides, and allowed to dry for months before they are to be used for sketching. I have used the terms sketches and studies without proper definition of the terms perhaps; by a sketch I mean the elements of a picture and by a study I mean practice of methods, and second of how certain objects are best represented pictorially. In fact the meaning of the word is correctly applied because such efforts are studies of how the objects look and how they can best be represented on canvas or paper. The illustration given with my article in February is a good illustration of a sketch and the one accompanying this a study of a rock.

What Waltham is Doing for the Watchmakers of the World.

BY WENDEL F. FOSTER.



HAVING PROMISED the readers of THE CIRCULAR to tell them what Waltham was doing for the watchmakers of the world, and, being personally acquainted with the several gentlemen to be mentioned in these papers, I take the liberty of giving my fellow craftsmen the benefit of my observations while visiting their well-equipped establishments. We will begin by visiting the building of the celebrated American Watch Tool Co., which is, without question, the largest manufactory of watch machinery in the world. This is located on the south side of Charles River, in what is known as the "Chemistry District," and is a convenient two-story brick building, comprising a square front 60x40, containing offices, drafting room, packing room, etc., with a wing in the rear 90x30 containing the workshops, all high and well-lighted. On the first floor are all the heavy machines, such as planing, shaping, milling and grinding machines, and one sees some fine work even in this room. In the rear of the machine shop is the blacksmith shop and engine room. The motive power is furnished by an engine of 15 horse power and a boiler of 20 horse power. On the second floor is the shop proper. On all sides are heavy wall benches containing the bench lathes and small machinery. This arrangement gives every workman a window to himself, and is the plan adopted in the machine shops of the principal watch factories. Where heavy machinery is necessary it is ranged in lines lengthwise of the room. The workmen, of which there are 70 all told, including several nimble-fingered young women, who work to advantage on numerous small parts, are divided as follows: thirty are employed on "Whitcomb" lathes and forty on factory machinery. They are well paid and of superior skill in their several departments of labor. The best of tools are furnished to them, and, as a rule, they become very expert in their use. Standard gauges are used for everything, and the metric system of measurement is the only one allowed. One sees here many machines and tools that would extremely puzzle the old-fashioned machinists. Especially interesting are the machines for grinding inside and outside of spindles, chucks, etc. The splitting and opening of chucks is also very nice work and requires considerable skill. J. E. Whitcomb, the veteran lathe maker, looks after every detail of the work, and nothing escapes his "Argus eyes."

Most of the work is on the popular No. 1½ lathe and its attachments. A few No. 1 lathes are built, but the demand is limited. The No. 2 is the lathe used by most of the experts, and is an especial favorite with the chronometer makers; but the number made each year seems small as compared with the No. 1½ size. This last

named is the leading size and has been adopted by all the lathe makers, but is called differently by them, some calling it by number and some by letter. The output of lathes is over seven hundred per year, and of foot wheels over five hundred per year. The No. 3 lathe is made in three sizes and has numerous attachments, one called the "Globe Valve" being very ingenious. The slide spindle lathes made by this company are perfect, and their bench lathes are used in every watch factory in the country. The American Watch Tool Co. have equipped entire or in part the following named factories: Columbus, Aurora, Peoria, Hampden, Waltham, Seth Thomas, Cheshire, Trenton, Waterbury; and the following clock companies: Boston Clock Co., New Haven, Parker Whipple Co. and W. L. Gilbert Co. They have also furnished tools and models for type writing machines and a large amount of machinery for electrical companies. Not only at home, but abroad, has this company become noted, having filled numerous large foreign orders, mostly from England and Switzerland. Among the special machines built for watch and clock making are automatic pinion cutters, wheel cutters, staff turning lathes, punches and dies, epicycloidal machines, slide spindle lathes and milling machines, etc. Its customers include almost every watch factory in America. "Yankee genius" comes smiling to the front whenever any real business in this line is to be done. Nor is this all; the company has also filled orders for machines of mathematical precision and of the most delicate construction, which have won for it a justly enviable reputation both in this country and in Europe. The enterprising manager of this firm is Ambrose Webster, who for many years was the assistant superintendent of the American Waltham Watch Co., which position he resigned in 1876 to form his present co-partnership with John E. Whitcomb, under the name of the *American Watch Tool Co.*, and it is due to his energy and experience that such excellent results have been obtained by this company. Mr. Webster is also inventor of the "Webster Foot Wheel" which is already a favorite and has come to stay.

In the next paper I shall speak of the establishment of John Stark, Jr. I would here take the opportunity to say to my brother watchmakers that it will be time well spent for them to make a trip to old Waltham and visit the three large watch tool companies, and see for themselves what one can but poorly describe. A practical man will see much to interest and instruct him, and give him broader views and more progressive ideas on that most interesting subject—watchmaking.

Purity of Electro-Deposited Metals.

IT IS A common belief among the uninitiated, and, for all that, among the initiated, that electro-deposited metals must necessarily be pure. This state is not by any means necessary; they are rarely pure, and the reason, probably, why the popular notion has arisen that they are very pure, is because copper is the metal most frequently deposited, and such copper happens to be an exceptional instance of purity. The degree of purity of deposited metals depends chiefly upon the degree of purity of the solution; if that is pure the deposit is likely to be so, and will be so unless it unites with the hydrogen liberated simultaneously with it, or with any of the constituents of the liquid, as in the instance of amorphous or explosive antimony. The purity of the solution largely depends upon the circumstance whether the anode is pure, and whether its impurities are soluble in the liquid; if they are not, they cannot be deposited; if they are soluble, then their deposition or not will largely depend upon various circumstances. The great purity of electro-deposited copper is largely dependent upon the fact that any lead contained in the anode is insoluble in a sulphate solution, and any zinc contained in it is too electro-positive in an acid solution to be thrown down with the copper.

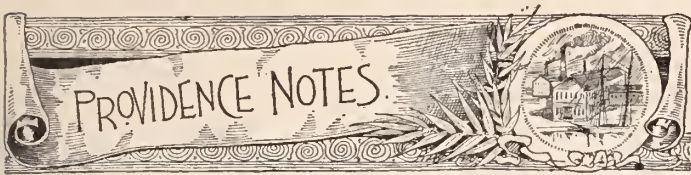

[FROM OUR SPECIAL CORRESPONDENT.]

PROVIDENCE, R. I., March 15, 1888.

Business has quieted down wonderfully in this city since you last heard from me, and already many of the manufacturers have commenced to run on short hours with a reduced force. This does not look very bright for the spring business. The jobbers in the West and Southwest say there is very little doing, and some of them have been known to cancel orders or reduce them one-half before the manufacturers have had time to fill them, politely informing the manufacturer that they would try and favor him later on if they found that they really needed any of his goods. This style of doing business is not satisfactory, as part of the order is generally finished when the order to cancel is received, and oftentimes proves to be dead stock, occupying much room in the safes, and having eventually to be closed out in job lots for a mere song. The open and warm winter has had a great deal to do with the poor state of trade with the jewelers to-day; business in a number of lines has been very poor during the past six months, stocks of goods have not been disposed of, but are on hand to-day. Consequently so much capital as they represent is virtually tied up, and the dull business with the manufacturer is only the reflection of the dulness existing in other branches on which the jewelry branch is dependent for its life and activity. The money market, to judge from the manner in which accounts have been settled during the past month, must be extremely tight. Collections have been very slow and little money has changed hands between the jobber and manufacturer. The feeling seems to be to hold on to funds until times look more bright and encouraging. Great conservatism is being shown this spring.

Mr. L. Towne, on his retiring from the late firm of Dunham & Towne, was presented by the employees with a gold headed cane, suitably engraved for the occasion. Mr. Towne responded in his usual happy manner.

The Rhode Island Yacht Club held its annual banquet at the Narragansett Hotel on Thursday evening, the 14th ultimo. Amongst the members present were noticed the following manufacturing jewelers: Hiram Howard, E. L. Logue, C. G. Bloomer.

The case of Babbitt *vs.* Cameron was again before the Supreme Court on Saturday, the 16th, on the petition of Henry A. Monroe, administrator of Joseph B. Mathewson, late receiver of the insolvent firm of Babbitt & Cameron, for an allowance as compensation for the services of M. Mathewson. A decree was entered allowing the account presented by the administrator, with the exception of his charge for such services, which the court allowed at \$250 instead of the sum charged in the account, and the present receiver was directed to pay.

The following named jewelers were noticed attending the supper of the Commercial Club at the Narragansett Hotel, as guests, on Saturday evening last: Messrs. John M. Buffinton, Geo. H. Holmes and Wm. H. Thurber.

Daniel R. Child, of North Swansea, was in the city during the week past, and reported business to be very fair.

D. S. Spaulding, of Mansfield, Mass., made a flying trip to the city last week.

R. A. Kipling returned from Paris per the French line steamer *La Gascogne* on the 3d inst., after a quick and pleasant trip. He brought many unique designs in different kinds of stone.

W. H. Ryder, the able representative of the Scovill Manufacturing

Co., of Waterbury, Conn., was in the city the past week, and reported business to be good, excepting with the manufacturing jewelers, who, he said, were somewhat quiet for the want of orders.

William H. Luther, of W. H. Luther & Son, reports a good business so far this year.

Frank T. Pierce, Ira G. Whittier, H. C. Whittier, John W. Case, Geo. B. Arnold and H. F. Carpenter have been elected members of the Young Men's Republican Club of this city.

Chas. F. Irons, of No. 102 Friendship street, is showing a finer line of pins, charms and emblems to the spring trade than ever before.

The will of the late Frank E. Capron, who died on January 13, has been approved, and Nannie M. Capron has been appointed executrix.

Foster & Bennett have commenced the manufacturing business at No. 102 Orange street.

Joseph H. Fanning, of Fanning & Potter, is again to be seen on the street after a short illness of some ten days.

The annual banquet of the New England Manufacturing Jewelers' Association, which was to have taken place during the month of January, but which was postponed on account of the death of the President, A. L. Potter, will be held some time next month, the date and place of same to be announced in the daily papers.

The sale of the effects of John McElree, of Charleston, S. C., whom some of the manufacturers here suffered by, netted only about \$3,000. As the liabilities amount to about \$19,000, the percentage on claims will not be over ten cents on the dollar after deducting the lawyer's fees.

George Pitts is around again after being confined at home two weeks with a bad attack of erysipelas.

The assignee, C. C. Gray, of the late firm of B. L. Hall & Co., has adjusted a settlement of all claims at twenty-six cents on the dollar.

C. Robert Linke, a jeweler, on Westminster street, has assigned to H. S. Fink, of Fink Bros.

The estate of John H. Hammond has closed out its jewelry business on Dorrance street.

Hearn & Braitsch, of No. 121 Broad street, have leased the shop formerly occupied by N. Grant & Co., which will increase their facilities and give them more room in which to accommodate their constantly increasing business.

The manufacturing jewelers are again receiving orders from J. M. Chandler & Co., of Cleveland, Ohio, who recently failed. It is said that J. O. Conrad will conduct the business under the firm name of J. M. Chandler & Co.

Brown & Dorchester have opened an office in New York at Nos. 41 and 43 Maiden Lane, Room 12.

John Hoagland & Co. report business as being very satisfactory so far this season.

O. C. Devereux & Co., of No. 224 Eddy street, has been making extensive alterations of late in his factory and office.

The following well-known jewelers are members of the West Side Club in this city: Chas. Downs, H. S. Dorchester, John M. Buffinton, R. S. Hamilton, R. S. Hamilton, Jr., Edwin Lowe, Wm. H. Luther, S. H. Manchester, Frank T. Pearce, Wm. Blackinton and Geo. L. Vose.

The Gorham Manufacturing Co. has petitioned the General Assembly for an amendment to their charter, which is generally understood to mean an increase of their capital stock.

Foster & Bailey are meeting with largely increased sales on their latest shoe button, the "Omega."

Waite, Thresher & Co. have added to their already extensive

plant the shop formerly occupied by Howard & Son, on Orange street.

Safford's Jewelers' Mercantile Agency reports business during the year 1888 to have been the best in their experience.

Fowler Brothers went down the road on Friday, March 1, and returned with about twenty pounds of those fine speckled trout in which the southern part of the State abounds. FAIRFAX.

The Jewelers' and Tradesmen's Company.

GILBERT T. WOGLOM, *President.*

THOMAS A. YOUNG, *1st Vice-Pres.*

SHUBAEL COTTLE, *2d Vice-Pres.*

EPHRAIM S. JOHNSON, JR., *Sec'y.*

SAMUEL W. SAXTON, *Treasurer.*

BOARD OF DIRECTORS.

JAMES A. SMITH,..... M. B. Bryant & Co.
 EPHRAIM S. JOHNSON..... Treasurer, E. S. Johnson & Co.
 SAMUEL W. SAXTON..... President Solid Link Chain Mfg. Co.
 CHARLES A. FOWLER..... Fowler Bros.
 JOHN C. DOWNING..... Downing & Keller.
 SHUBAEL COTTLE..... President S. Cottle Company.
 THOMAS A. YOUNG..... Ex-President National Association of Commercial Travelers ;
 Chairm'n Legislative Committee and Vice-President of the Commercial Travelers'
 Ass'n, State of N. Y. ; President Traders' and Travelers' Union.
 CHARLES F. ROBERTS, M. D., *Medical Director*, 69 E. 54th St., N. Y. City.
 SAMUEL A. BALDWIN..... W. E. White & Co.
 GILBERT T. WOGLOM..... Gilbert T. Woglom.
 WILLIAM B. KERR..... Kerr & Battin.
 SAMUEL SONDEHEIM..... Bruhl Bros. & Co.,
Superintendent, BENJAMIN O. LAMPHEAR,
Counsel, JAMES M. HUNT..... (of Rudd & Hunt) 31 & 33 Pine Street.

At the several sessions of the Executive Committee held since March 1, the following have been granted certificates of membership:

Frederick G. Cole, Chas. F. Hawes, Emanuel G. Rose, with J. Bulova, Cassius W. Seymour, with Plainville Stock Co., John D. Dalzell, with G. & S. Owen & Co., F. Appleton Smith, with Robbins & Appleton, Aaron H. Zeckendorf, with H. H. Heinrich, Moses L. Van Moppes, with D. L. Van Moppes, Louis Stirn, with G. Rhein-hauer, Jacob Rosenberg, A. Alling Reeves, Ira Seebacher, with J. Bernstein, Geo. E. Hamlin, of Geo. E. Hamlin & Co., Henry Hyman, with Pforzheimer, Keller & Co., Ernest Burgdorf, with Wilkinson & Co., Geo. B. Beiderhase, of Ferd. Fuchs & Bro., Solomon Blog, with R. H. Ramsgate, Geo. G. Bugbee, with E. S. Johnson & Co., John H. Maxheimer and Geo. C. Beresford, of Maxheimer & Beresford, Henry J. Haigh, Albert Monte, Chas. E. Mather, of Mather & Wentworth, all of New York City; Gebhard Krauss, Brooklyn, N. Y.; Joel A. Chatfield, Middletown, Conn.; Howard C. Rowbotham, with H. Muhr's Sons, Philadelphia; George Lockwood, Stamford, Conn.; Richard H. Steele, Jersey City, N. J.

Additional medical examiners have been appointed as follows: Jersey City, N. J., Dr. John Nevin; South Norwalk, Conn., Dr. A. N. Clark; Stamford, Conn., Dr. R. L. Bohannen.

least from its brilliant success, and, indeed, the parlors of the state suite never presented a more animated appearance than they did during the assembling hour, from five to six in the afternoon.

Baldwin's cadet orchestra furnished the music for the grand march to the banquet, where a magnificent dinner was served to about forty gentlemen and their accompanying ladies. Among the company were Mr. and Mrs. Chas. Harwood, Mr. and Mrs. E. C. Fitch, Mr. and Mrs. Irving Smith, Mr. and Mrs. D. C. Percival, Mr. and Mrs. Andrew Paul, Mr. and Mrs. A. T. Morrill, Mr. and Mrs. James S. Blake, Mr. and Mrs. Drinkwater, Mr. and Mrs. A. E. Whitney, Mr. and Mrs. Southworth, Mrs. W. Paul, Mr. Scofield, Mr. Peterson, Mr. and Mrs. Austin Sylvester, Mr. and Mrs. C. F. Morrill, Mr. and Mrs. Lang, Mrs. Rounds, Mr. Pratt, Miss Harwood and W. Harwood.

The guests of the club were E. C. Fitch, President of the Waltham Watch Company, who was accompanied by Mrs. Fitch, and Mr. Scofield, New York representative of the Elgin Watch Company. A. W. Harwood, the club's president, sat at the head of the table, and after the dinner introduced toast-master C. F. Morrill, who opened the speechmaking with the following graceful remarks:

"*Mr. President, Ladies, Members and Guests:*—At the request of our President and the Committee on Entertainment, I have consented to act as master of ceremonies for this evening. Our club dinners have heretofore been confined to gentlemen guests and have been very informal in their nature. This occasion is a new departure for us, but I feel that this present occasion, graced with the presence of ladies, will be repeated many times."

Of course, that put everyone in good humor, and when the applause ended Mr. Morrill announced as the first toast:

"*The United States; great in resources and power, foremost in prosperity and strong through the intelligence of her people.*"

It was Austin Sylvester, of the firm of H. T. Spear & Son, who responded eloquently. The next sentiment:

"*We are Proud of Her Part; may her sons and daughters of the future vie with each other in promoting her prosperity and influence.*"

It was answered by James S. Blake, of the firm of J. V. Kettell & Co. Irving Smith, the Secretary, and one of the most energetic of the club's organizers, responded for the toast:

"*The Boston Jewelers' Club; may every success attend it.*"

"*The Ladies; whose presence here lends to the evening its crowning charm, and upon whose influence depends the character of men and the strength of nations,*"

Called William H. Pratt, of the firm of Floyd, Pratt & Rounds, to his feet; and

"*Our Guests; who have honored us with their presence,*"

Called for a delicate little speech from President Fitch, of the American Watch Company. David C. Percival answered for

"*The National Association of Jobbers,*"

And Andrew Paul spoke in a happy vein for
 "The Wholesale Jewelry Trade of Boston; the standard of business ability, integrity and prosperity"

"The next toast is a marriage toast," announced Mr. Morrill, "and will be responded to by a married member of the club. (Laughter.) I take pleasure in proposing:

"Canada and the Provinces—the Maiden Sister of the North; may they all wed the United States."

It was Mr. Scofield, of the Elgin Watch Company, who answered, and with him ended the toast-making of the evening, which was brought to a delightfully informal close with Mrs. Austin Sylvester's spirited rendering of "Nothing but Flags."

It is reported that Henry A. Prentice, formerly of the H. A. Prentice Company, who has been lately in town adjusting his wife's estate, has accepted a traveling salesman's position with the Bay State Watch Case Company.

On the 4th inst. the jewelry stock of Abel Burrows, No. 89 South



[FROM OUR SPECIAL CORRESPONDENT.]

BOSTON JEWELERS BANQUET.

BOSTON, March 17, 1889.

The reception and dinner of the Boston Jewelers' Club, at the Vendome, on the 5th inst., were brilliant affairs, and together constituted a notable occasion in the history of the trade. The fact that it was made complimentary to the ladies didn't detract in the

Main street, Fall River, was sold at auction by order of Assignees Myers and Wood.

The attachment of Wm. H. Zinn, fancy goods and silverware dealer on Washington street, has created general surprise. It seems that Mr. Zinn contracted some time ago with builder Wilbur P. Rice for the erection of ten houses in Somerville for \$22,000; \$18,000 of this has been paid, but Mr. Zinn is dissatisfied with the work. The original attachment by Rice was for \$40,000, but has since been lowered to \$10,000, for which bonds were given. The difficulty has postponed Mr. Zinn's contemplated pleasure trip, and the whole affair will have to be adjusted in the courts.

Simon W. Bailey, of 353 Washington street, who assigned recently to D. C. Percival, has liabilities of \$4,500, one-quarter of which is owed to merchandise creditors. His stock is encumbered with a \$2,700 mortgage.

Jeweler John M. Humphrey, of Lynn, has mortgaged his stock and fixtures for \$6,000, payable in one year, to Morrill Bros. & Co., of this city.

The Boston Jewelers' Club is nearly a year old, and most of its thirty members are jobbers. It is proposed by the management to soon broaden the scope of the organization so as to take in the manufacturers.

Willard Farrington, son of the late John Farrington, will continue the business of the old house of Farrington & Hannewell, at 8 Waltham street. His deceased predecessors were partners for one-half a century, and he himself has been connected with the firm for thirty years.

The H. A. Prentice Company caused the arrest of Edward L. Williams for illegally obtaining \$200 worth of watches last July on memorandum. His failing to either return the goods or settle for them caused the trouble.

C. E. Davis, formerly in business on Hanover street, has become the Tremont Loan Company's appraiser.

There isn't a more delighted man in the business than Simon Lewis, of 52 Kneeland street, who has recovered his \$300 diamond that a New York crook captured.

Arthur C. Vose and Miss Annie Meader have gone into business partnership as A. C. Vose & Co. The new firm will do a wholesale and retail business in watches, clocks, jewelry and silverware at 11 Hanover street. Vose has had charge of the jewelry and silverware department of Horace Partidge & Co. for eighteen years, while Miss Meader comes from the Attleboros with long experience in the trade.

The failure of E. E. Burdon & Co., on Franklin street, has created a sensation. E. E. Burdon claims to have lost \$12,000 since January 1.

D. C. Percival & Co have engaged E. W. Merrill, formerly with L. S. Stowe & Co., of Springfield, as traveling salesman.

The Middlesex Club entertained Mayor Fisher, of Waltham, a few weeks ago, at Young's. The Mayor is officially connected with the American Waltham Watch Company.

The funeral of J. Bennett Thaxter, son of manufacturing jeweler Joshua Thaxter, took place on Thursday, February 19.

Wm. H. Taplin and Daniel L. Tirrell have organized as Taplin, Tirrell & Co., to manufacture jewelry, at 375 Washington street, as the successors of Taplin & Co. The new firm have mortgaged their tools and fixtures to Frank O. Sharp, a former partner of Mr. Taplin, for \$2,000, to be settled in two years.

Thomas Long & Co. have opened a jobbing business at 77 Sumner street.

J. B. Hamblin has opened a South End branch at 175 Tremont street.

Wilson Bros. have opened a branch store at 284 Tremont street.

E. B. Horn has contracted with Keening & Strout for the erection of an apartment house at 189 and 191 Botolph street.

The creditors of jeweler S. Gatchel, of Waltham, are compromising at 50 cents. Liabilities, \$800.

LEON.

American Jewelers Appreciated in Japan.



BEVY OF PRETTY girls who were crowded one afternoon recently around the counter of a Maiden Lane jeweler admiring his stock of beautiful jewels, exclaimed with delight as he held aloft for their inspection two glistening necklaces, one of silver, the other of gold. They were made of Japanese coins of various sizes each coin set in a framework of silver or gold, and linked together with tiny hooks of exquisite workmanship.

"What a delightfully odd design," cried one pretty girl.

"It is something new, that's a fact," replied the jeweler; "and what's more, there isn't anything like it in town, either. These coins were sent from Japan, through a New York importing house, to be made into necklaces as a present for some lady of social distinction in Japan. These gold coins are over 500 years old, and what makes them things of beauty from a jeweler's standpoint is the fact that the gold is absolutely pure, the coins being made without a trace of the alloy usually employed to harden gold that is to be used as money."

Then the jeweler dropped the necklaces and picked up a diamond set in a brooch and encircled by pearls. He also exhibited a curiously carved nut, faced with a plate of gold, that had a monogram cut into it. "These," he added, "are part of the same order, and are to be shipped to Japan next week."

Aside from the beauty of the workmanship, the order for the jewelry was a matter of comment in the local jewelry trade as an admission of the superiority of the work of American jewelers. The coins and diamonds and pearls had been sent across the sea simply because with all their skill, the Japanese gold and silversmiths are not able to produce work that will equal that produced by American workmen in the same branch of industry.

New York jewelers say that their American artisans have in conspicuous instances recently received the preference in foreign orders over the jewelers of Paris and London.

"Just as the Japanese send their boys to American colleges to be trained for engineers and the kindred professions," said a merchant, "they send to New York to get their fine jewelry. Japanese orders for the mounting of charms and the setting of precious stones are becoming an item of profit in the New York market. It is a big compliment to the art of our native workmen that these foreign customers should be willing to expend the increase in cost that is entailed in sending goods here and exporting them again in order to secure the work of Uncle Sam's artisans."—*N. Y. Sun*



[FROM OUR SPECIAL CORRESPONDENT.]

ATTLEBORO, March 18, 1889.

The jewelry business is very much like the New England climate—it is subject to sharp and sudden changes. Only a few weeks ago and the manufacturers were puzzled to know how they should fill their orders, but just now none of them are being troubled very much in this way. Everything seemed to be going on splendidly, business was booming and every firm was receiving orders, when suddenly they stopped coming, and during the past four weeks most every one has been running on short time. But this dullness probably took no one by surprise. The drummers with whom I have talked predicted it two months ago, but they are of the opinion that it will not last long.

ATTLEBORO.

This town is always looking forward to the time when some large establishment will locate here and give the place a boom, and by

employing a large number of workmen contribute to the growth of the place. For this reason they would welcome the Cheshire Watch Company if this concern were to come. While there is nothing further to report in the matter, those interested feel quite confident of carrying their point.

Blake & Clafin have been running on short hours much of the time for the past two or three weeks.

W. & S. Blackinton, chain manufacturers, find their orders rather light, and have been giving their help a little rest.

W. H. Smith, of the firm of Smith, Crosby & Smith, was a candidate for selectman of this town at the election Monday, but he failed of election.

G. A. Dean, a prominent jeweler, is enjoying a trip to California.

L. P. Sturtevant has withdrawn from the firm of Regnal, Bigney & Co.

NORTH ATTLEBORO.

Thomas J. Linton seems to have lost confidence in this town. He came here, as many others do, thinking that the town would be ready to grasp at the idea of having a mill of any kind here, but he went away a wiser man. His process of brass forging may be a superior one in every respect, but Mr. Linton couldn't make the business men see it.

The F. G. Whiting building was sold at public auction in the North Attleboro Bank Monday, February 25. There were no bidders, and the bank bid the property in for \$21,000, the face of the first mortgage.

One of the worst fires which has visited this section in a long time was that which was discovered in the old factory in the rear of the Gold Medal Braid Works, on the morning of March 1. D. H. Murphy & Co. and Joseph Wilcox & Co. occupied the building, and they suffered almost a total loss. The loss on building and stock is estimated at upwards of \$18,000, only partly insured. MENDON.

Electricity and Magnetism,*

AS AFFECTING THE PERFORMANCE OF WATCHES.

A brief statement of the general principles of electricity and magnetism, with a review of the various ways in which they can injuriously affect the performance of watches, and of the different methods employed for preventing or remedying such effects.

BY "EXCELSIOR."

Continued from page 56, March, 1889.



IN MY last article I mentioned the effects of magnetism upon watches, and how to detect its presence. In order that watchmakers may understand the "why and wherefore" of those effects, I will now state the general principles of electricity and magnetism involved, *i. e.*, a few of those most prominent and important, sufficiently for the comprehension of our subject. I shall endeavor to explain them so clearly that even persons who now know nothing about electricity or magnetism can perceive how they may affect a watch, and how those effects may be prevented or remedied.

Electricity, in the form of currents, may be produced in various ways, the most common being by voltaic "batteries" and by "dynamoes." There are many kinds of batteries, but for our explanations I have shown a simple form in fig. 4, *J* is a jar containing dilute sulphuric acid (say, 1 part of acid in 7 of water,) up to the line *xx*. In this liquid are a plate of zinc, *Z*, and one of copper or carbon, *C*. At the top of these plates are fastenings or binding posts with screws. In them are screwed the ends of the wire *ww*, which is to conduct our current where we want to use it. These binding posts are the "poles" of the battery. The one *out of* which the current flows is

the positive pole, and is marked +, while the one *into* which it flows on its return to the battery is the negative pole —.

Some metals are more "electro-positive" than others, and the latter are called "electro negative," relatively to the former. In the above arrangement the zinc is the positive metal, and the copper is the negative one. By that, we mean that the zinc is the metal which acts or is acted upon by the liquid, while the copper is negative or inactive. The zinc is gradually eaten away by the acid, and the amount of current produced is proportional to the quantity of zinc consumed. The copper remains, unconsumed.

The current always flows from the positive to the negative point, consequently it flows from the zinc to the copper in the liquid, as shown by the arrow, up *C* to the binding post marked +, through wire *ww* to the — binding post and zinc *Z*, thus completing its round or "circuit." This will make clear why the positive "pole" is attached to the negative metal or plate of the battery, and the negative pole to the positive plate—a point which seems to many very singular and mysterious.

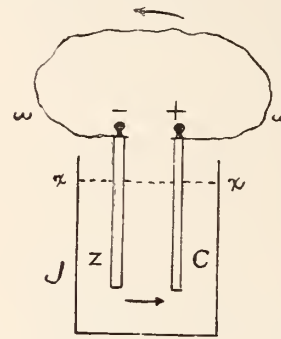

FIG. 4.

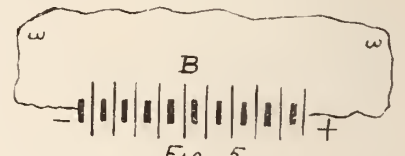

FIG. 5.

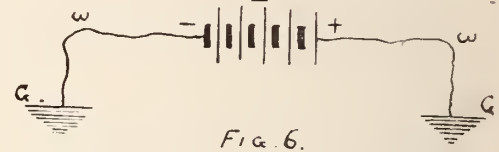

FIG. 6.

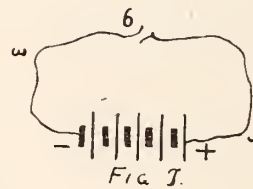

FIG. 7.

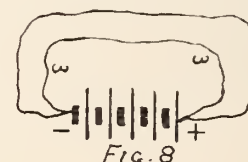

FIG. 8.

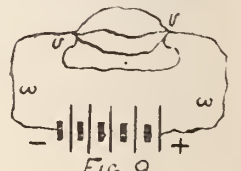

FIG. 9.

Some currents are stronger than others, and they can be measured as accurately as a stream of water. Like that, they differ in "volume" and in "pressure." If we make a hole one inch in diameter at the bottom of a reservoir of water, the size of the hole determines the volume of the stream, and the height of the water above the hole is the "head" or pressure forcing it out. The quantity which escapes is proportional to the size of the stream multiplied by the head. In a similar way the volume of current is expressed in "amperes," and the electro-motive force or pressure, in "volts." The product of the number of amperes of current into the number of volts of pressure gives the power of the current in "volts." 746 volts in current is one horse-power.

The ordinary Daniel or "gravity" battery commonly used gives a current of about one volt pressure, while a dynamo may produce a current having a pressure of one or several thousand volts. When a high-pressure current is wanted from batteries, a number of them are arranged tandem, or "in series." The copper of each jar is connected to the zinc of the next one by a wire, and the poles of the battery are then on the zinc at one end of the series, and the copper at the other. The current then flows through the whole series, and has the electro-motive force or pressure of all the jars. If the jars or cells of battery are alike, and each gives one volt pressure, then ten cells will give a current of ten volts, and so on. But the volume of the current will be the same as one cell alone could give, through the same resistance.

The volume of the current depends not only upon its pressure but also upon the "resistance" in the circuit through which it flows.

* Copyright, 1889, by The Jewelers' Circular Publishing Co.

Copper is generally used for the conductors because it has low resistance, or great conductivity. Resistance is expressed in "ohms." A No. 21 copper wire, 100 feet long, has approximately 1 ohm resistance, 200 feet, 2 ohms, and so on; while 1000 feet of No. 10 wire would have only 1 ohm resistance. The larger the wire, *i. e.*, the larger the cross-section of the conductor, the less the resistance, and *vice versa*; and the longer the wire, the greater the resistance.

The volume of current which will flow through a given circuit is found by dividing the number of volts by the number of ohms of resistance in the entire circuit, including the resistance of the battery itself. Thus, the current of our 10 cell battery would have 10 volts pressure, and if each jar had 1 ohm resistance and the wire *ww* practically no resistance, then the resistance of the entire circuit would be 10 ohms, and the current would be 1 ampère. But if *ww* had 10 ohms resistance in it, the total resistance would be 20 ohms, and the current would be only $\frac{1}{2}$ ampère, and so on. If there is a poor joint anywhere in the circuit, a loose screw, grease or dirt between two surfaces which should make good contact, or the like, the resistance there may be many ohms or hundreds of ohms, and will cut down the volume of current through the entire circuit.

In diagrams of electrical apparatus, a jar of battery is represented by two parallel lines, one shorter and thicker than the other, and a series of such couples signifies a battery of that number of jars, in series. Thus: Fig. 5 shows 10 cells or jars in series, with the poles of the battery connected to *ww*, and partly through the earth between the ends of the wires *ww*. This is called a "grounded" circuit, because the ends of the wires *ww* are connected to "grounds" or earth contacts at *GG*, making the ground a part of the circuit. The "resistance of the earth is extremely low—practically nothing. In the case of a telegraph line hundreds or even thousands of miles long, only one wire is required, as the earth serves as a return wire to complete the circuit, thereby effecting a great saving of expense. Many persons think that if the conductor through which a current flows is "grounded," there will be no danger of its affecting the running of watches near it. The fact is that it makes no difference in that respect, whether the circuit is grounded or is all metallic. The electromotive force of the battery is the same in both cases, and if the resistance of the circuit is the same, the volume of current will be the same; the currents being alike, the effects will be alike. In either case there is a complete and unbroken path for the current to flow through its circle or round, called a "closed circuit." If at any point the circuit is broken, (called an "open circuit,") *no current will flow* anywhere in the circuit. For instance, there is a break at *b*, fig. 7, and consequently no current flows, either through wires *ww* or through the battery from pole to pole. If the wires are touched or laid on each other at *b*, their rounded sides will have but slight surface in contact, called "poor contact," the resistance will be great, and the current very weak. Wires should be united by screw connections, or flattened where they touch, or soldered together, to make a good joint.

If, instead of one wire *ww*, as in figs. 1 and 2, there are two, or a dozen, or any other number of them, the current will be distributed among them in proportion to their respective conductivities, or power of conducting current. Or we may say that a current flows through every possible path open to it, its volume in each being inversely proportional to its resistance. If one wire has a very high resistance it will get but a small share of the current, while another, of very low will get a large share of it. Fig. 8 shows two circuits *ww* between the battery poles, and their joint-resistance, added to that of the battery, determines how much current will flow from the battery. That current will be divided between them according to their conductivities. The joint-resistance of two similar wires is one-half the resistance of one of them, and they will conduct twice the volume of current, just as two pipes would carry off twice as much water as one would. But if the resistance of one wire was two ohms, and that of the other one ohm, the latter would get twice as much current as the

former, *i. e.*, it would get two-thirds of the current flowing, and the former one-third.

In fig. 9, there is one wire through a part of the circuit, to points *vv* between which there are four branches, called "branch" or "derived circuits." In this case, the current which flows from the battery is found by dividing the electromotive force or pressure, in volts, by the sum of all the resistances, *viz.*, that of the battery, of the wires *ww*, and the joint-resistance of the branch circuits between *vv*. This current will then be divided between the branches in proportion to their respective conductivities, as before stated.

We are now ready to apply the foregoing principles, and understandingly examine the action of electricity and electric currents upon the performance of watches, which will be the subject of my next article.

(To be continued.)



[FROM OUR SPECIAL CORRESPONDENT.]

THE JEWELRY PALACE OF THE WEST.

CHICAGO, March 20, 1889.

The State of Illinois has conferred an honor upon the Chicago jewelry trade. Gov. Fifer yesterday appointed Henry A. Spaulding State Commissioner at the International Exposition in Paris. Mr. Spaulding has not occupied much time in gaining recognition, both in the trade and among those prominent in State and municipal affairs. Nor has it taken him long to prove to this, the city of his first mercantile endeavor, that his long residence in Paris has not made him forgetful of the enterprise expected of all hailing from this seat of energy and bustle. Your observer found it somewhat difficult to reach Mr. Spaulding yesterday, as he busily superintended the work now in progress in the vast treasure house over which he presides. Ever since the sign of N. Matson & Co. gave place to that of Spaulding & Co., incorporated, no day has passed without witnessing innovations and renovations which are destined to create a palatial jewelry establishment second to but one in the country. Some of the ideas are so novel and effective as to be worthy of both mention and imitation. The visitor aiming to be critical and to miss nothing in his round of observation, would find himself dazed did he not begin at a definite starting point and so gradually make the round. Even the basement, given over to receiving and packing rooms, polishing lathes and the use of employees, is not without interest. The separate lockers for each attaché of the house, the separate toilet rooms, even to the boot-blackening platform with its brass foot form, add the quaint admonition denoting its purpose lettered upon it, evidence that close attention to small details which is sure to have its influence upon the minds of all employed about the premises. Electric lights and machinery operated by the same power, save the heat and dirt, usually so helpful towards ill-health and waste, and guided by the incandescent bulbs we ascend to the main floor. The first thing noticed at the top of the stair landing is a ladies' dressing room. In it are richly embroidered towels and various adjuncts of the toilet feminine, into which mysteries no man can be sufficiently initiated to describe understandingly. The maid with white cap and apron of broad and snowy expanse is a negress; a smiling and picturesque study in black and white. She is stationed midway between this dressing room and a buffet, laden with delicately tinted and decorated china. A steaming urn of tea is near, lemons also and sugar for the serving of it *a la russe*. But these are not the only conveniences afforded the ladies. If the visitor notices

some gold lettering, reading "gem boudoir," and opens the door over which they appear, he will find himself encircled by a satin hung wall. Above him a canopy of like material, domed with a circle of colored electric bulbs. Mirrors reflect his person on all sides, and here the woman wishing to notice the effect of a diamond necklace when worn at night with a low-cut bodice and powdered hair, can afterwards emerge in her street costume, having enjoyed as luxurious privacy as would be offered in her own home. Passing now towards the salesrooms we see a bulletin board, showing arrivals and departures of trains and the sailings of European steamers. Scarce noticing the general offices or the balcony overhead, attention is centered on those who, separated from us by a glass partition, are looking over loose diamonds and precious stones. Just here begins a long row of show cases, filled with diamonds and jewels in settings of more distinct and artistic shapes than could be described in pages. We have now reached the watch department, completing the north side of the establishment, the watch repairing department being just back of the watches themselves. The south wall is lined with cases filled with sterling silver and silver plate, in which latter department nothing of lesser value than Gorham quadruple plate is kept. Between these two walls are two marble aisles, each perhaps fifteen feet in width, and between these aisles all the thousand and one articles of jewelry coveted by the people of this generation. Bronzes also, and objects of art. Dainty Parisian conceits, lace fans, lorgnettes and bijouterie in general. Even now we have not spent any time noticing the workmen in the manufacturing or engraving departments, nor have we stopped to enjoy separately any of the almost priceless jewels. Perhaps it is as well to leave the description of these until it becomes the "observer's" duty in next month's CIRCULAR to tell of a dazzling exhibit now in preparation for the formal opening of Spaulding & Co.'s premises, to occur during the first week of next month.

Morse, Williams & Co. succeed the firm of F. E. Morse & Co., at 137 and 139 State street. It may possibly be reported next month that the firm name has again changed; if so, it will become Morse, Williams & Mitchell. Should the change occur it will be occasioned by the fact that a firm of Philadelphia elevator manufacturers, who are about to open a Chicago office, style themselves Morse, Williams & Co., and by reason of longer establishment they would naturally receive from Uncle Sam the mail intended for the jewelers. It is hardly to be supposed that the elevator men would place much value on orders for diamonds and watches, nor would the jewelers be apt to send many hoisting machines by express to their customers, nevertheless a distinction of some sort in the firm name will prevent a mix. Fred. C. Williams, who has now joined his fortunes with Mr. Morse, is a New Yorker, and G. H. Mitchell, the third member of the co-partnership, comes from Hartford, Conn. It is reported that the collective wealth of these three gentlemen nears a round million. They naturally expect, therefore, a considerable growth over the business done by the former firm of F. E. Morse & Co. If appearances count for anything, Mr. Morse finds most satisfaction in this increase of his prestige and power, from the fact of feeling himself still better equipped for the war against the "American Watch Manufacturers' Association." His presence before the house committee at Springfield will be remembered, as having been noted in our last month's correspondence. It is perhaps two years ago since Mr. Morse was expelled from the Association, and impartial candor compels the statement that not a few, even among his competitors, think the expulsion unjustified. It occurred through the sale to the Thomson & Taylor Spice Co., by F. E. Morse & Son, of some nine thousand dollars' worth of watches during a period of three or four months. Mr. Titus, a salesman of the house, according to Mr. Morse's statement, not realizing the binding offers of the agreement required by the American Watch Manufacturers, assumed the responsibility, without the knowledge of his firm, of billing in place of a certain watch movement, which was out of stock, another costing \$1.25 more, at the same price. This occasioned a difference of

some \$37, which also occasioned a complaint made by a Chicago house, by reason of which F. E. Morse & Son were debarred from further purchase from the manufacturers included in the combination. Some time after this Mr. Morse, then representing the E. N. Welch Clock Co., bought out the western agency from his employers and started the new firm of Francis E. Morse & Co. This new firm applied for membership to the American Watch Manufacturers Association, but for one reason or another the application was rejected. This was a year ago, since which time Mr. Morse has waged incessant war against the combination. Regardless of the points in controversy, Mr. Morse has many admirers in Chicago, and is both sufficiently shrewd and popular to occasion his opponents considerable watchfulness.

In the same building are the rooms of the Fort Dearborn Watch and Clock Co., the incorporation of which was announced by THE CIRCULAR last month. D. A. Wilkins is its secretary and manager, and their card bearing the imprint "agents of the people," for watches, clocks, silverware, diamonds, jewelry and novelties, explains to all interested that it is to the consumer, and not to the trade, that this new corporation looks for patronage.

Wm. H. Gilman, on Madison street, is going out of business, and is now closing out his stock at auction.

C. C. Lovell, of Racine, Wis., has also tired of the jewelry traffic, and will seek the wilds of Oregon or Washington Territory.

Simpson, Hall, Miller & Co. seem as busy as usual, and that is saying much. Their ledger shows their sales to be ahead of last year up to date, but the report of the trade generally is that there is no occasion for working overtime in filling orders. In fact, it may be stated that the Chicago wholesale jewelry trade is a little drowsy. Collections still rule good, and the outlook for a prosperous season is favorable.

As might be expected from the tenor of the above paragraph, not many buyers from out of town are in the city. J. A. Todd, manager of the Towle Manufacturing Co., returned to the city yesterday from a three weeks' trip in the East. Among the buyers of the novelties in silverware made by this company, we noticed last week Mr. Walter H. Thompson, of J. G. Thompson & Son, Sioux City, Ia., who, although on his way back from the eastern market, was tempted to add a fairly good bill of their popular wares.

Other out of town buyers here recently included Chas. Rowe, of F. G. Smith & Sons, Detroit; A. C. Bienz, Bessamer, Mich.; A. Helfrich, Burlington, Ia.; J. Wittelshafer, Grand Forks, Dak.; Geo. M. Warren, Spring Valley, Minn.; Geo. Baldy, Rockford, Ill.; S. W. Saunders, Marengo, Ill.; H. F. Miller, Milwaukee, Wis.; E. Goldberg, Manistique, Mich.; Steele Hartly, Chrisman, Ill.; S. McCluer, Glenwood Springs; J. A. Runmele, Milwaukee, Wis.; Edward Phelps, San Francisco. Other visitors to the city were C. J. Olin, of Piqua, Ohio, and Messrs. Wilcox, Rockwell and Jepson, of the Meriden Britannia Co.

E. F. Moore, of Benj. Allen & Co., is having a respite in New Orleans, and Sam Loeb, of H. F. Hahn & Co., is resting up, after having made the trade in Ohio and Indiana believe his jewelry worth more than their dollars.

The Illinois Optical Company has been incorporated by E. J. Woodward, L. P. Wilcox and F. M. Charlton with a capital of \$200,000.

A report that the R. W. Sears Co., which has never been a corporation except in name, had been incorporated by the successors to Mr. Sears, is incorrect. The license has, however, been issued, and the company will be incorporated within a day or two. At present Edward B. Butler, of the widely known firm handling cheap counter supplies, is the sole owner, and he will probably so remain after the incorporation, his only idea being to keep the concern distinct and separate from that of Butler Bros. His purchase of the stock happened in this wise: A. G. Evans, who has been in the employ of the J. B. Chambers Co. here, is a friend of Mr. Butler, and he has,

from time to time, told him of the big watch traffic done by this young man Sears, who but two years ago was a telegraph operator on a railroad. Some two weeks or more ago Mr. Evans came flying to Mr. Butler with the information that Sears would sell out, and Messrs. Moore and Scofield, two of Butler Bros. employes, were deputized to investigate the affairs of Sears' business. The investigation proved so satisfactory to Mr. Butler, that he paid Mr. Sears \$52,000, which is about the net result of two years' work for the latter. It is said by the trade that Sears was one of the largest customers that the Dueber company had. His great specialty was a silverine watch case, which cost him something less than seventy cents; into this case he put a Swiss movement, costing \$1.50 or less, and the whole outfit was sold as "warranted solid silverine" at \$3.98, to the great profit of Sears, if not to the fellow who parted with his \$4. Some of these watches, no doubt, were swapped by the buyers as solid silver, without the "ine," for spavined horses, but in such cases probably neither fellow got the best of the bargain and no one need complain. Sears always bought for cash, and is considered shrewd but honest.

Mr. Smith, of the Geneva Optical Co., is in Eureka Springs, Ark., on account of ill-health; he probably will remain there for a month or so yet.

W. A. Bigler, one of the most popular attachés of Spaulding & Co., leaves Chicago to-night to become identified with the Paris house of this well-known corporation. Mr. Bigler will not get sea-sick; he has traveled around the globe several times, and a pocket full of loose jewels always accompanies him on these excursions.

THE CIRCULAR'S OBSERVER.



The following list of patents is compiled from the records of the United States Patent Office, and specially reported to THE JEWELERS' CIRCULAR.

Issue of February 26, 1889.

398,657—JEWELRY. EMIL SCHILL and ANDREAS BECKER, Newark, N. J., Filed September 20, 1888. Serial No. 285,848. (No model.) This improved setting combines a raised blank or body portion of sheet metal, the outer rim of which is bent at right angles to said body portion to form a bearing, provided with a recess or groove, a flange, and a gallery secured to said flange provided with grasping fingers, and co-operating with the groove-bearing to hold the jewels firmly in place.

398,787—EAR RING OR OTHER JEWELRY. ADOLPH LUTHY, New York, N. Y., assignor to A. Luthy & Co., same place. Filed February 24, 1888. Serial No. 265,145. (No model.) In combination with the base there are a stem projecting therefrom, and a laterally projecting fastening crank arm borne by said stem, and constructed to be adjustable toward and from the base.

Issue of March 5, 1889.

398,835—KEY RING. ROBERT H. INGERSOLL, New York, N. Y. Filed June 13, 1888. Serial No. 277,022. (No model.) This article consists of a circle of wire constructed of spring metal, and provided with inclined notches in the upper edges near both ends; and of a detachable clasp so constructed as to fit over and cover the notches and ends of the ring, the clasp being provided with cross bars designed to be adapted to engage with the notches, and to be securely locked therein by the resiliency of the ring.

398,896—ELECTRIC ALARM CLOCK. SAMUEL KAHAN and ALBERT W. CRAVEN, Melbourne, Victoria. Filed October 13, 1888. Serial No. 287,983. (No model.) This invention consists of a combination in an alarm clock with one of the quick-going arbors of the going train, a make-and-break device interposed in an alarm circuit, a ratchet-and-pawl connection between the two, a shifting mechanism adapted to move the pawl into and out of engagement with the ratchet, and a controlling cam operated by the slow going arbor.

399,097—CLOCK CASE. ALFRED D. TYRRILL, New Haven, Conn., assignor to the New Haven Clock Company, same place. Filed November 5, 1888. Serial No. 289,991. (No model.) A circular sheet metal clock case in two parts, front and rear, divided by a plane at right angles to the axis. The front consists of a glass with border, combined with the clock movement constructed with a circular flange having notches adapted to engage and lock with two or more projecting studs in the flange of the rear portion.

398,957—WATCH CASE PENDANT. FRANK G. FAXON, Mount Morris, N. Y. Filed October 9, 1888. Serial No. 287,650. (No model.) In this watch pendant the stem is provided with a collar and two springs, one on each side of the stem, and arranged horizontally, the lower ends being fastened in the main part of the pendant, and the upper provided with heads to lock in recesses in the collar, the object of this being to hold the stem in position while winding or setting the watch.

Design Patent 18,943 and 18,944—BRUSH OR MIRROR BACK. HENRY BERRY, Shelton, Conn., assignor to the Derby Silver Company, same place. Applications filed January 14, 1889. Serial Nos. 296,296 and 296,297. Term of patents, 7 years.

Trade Mark No. 16,328—WATCHES AND THEIR COMPONENT PARTS. ANC. FQUE. VACHERON & CONSTANTIN (Limited), Geneva, Switzerland. Application filed January 25, 1889. Used since January 1, 1889. "The representation of two crosses of the Maltese type, the outer edge of the arms of one cross being straight and the equivalent edge of the arms of the other cross being essentially triangular."

Trade Mark No. 16,354—SPIRAL OR VOLUTE SPRINGS FOR WATCHES. USINE GENEVOISE DE DEGROSSISSAGE D'OR, Geneva, Switzerland. Application filed November 9, 1888. Used since September 15, 1888. "The representation of a bowed arrow."

Trade Mark No. 16,355—BALANCE WHEELS FOR WATCHES. USINE GENEVOISE DE DEGROSSISSAGE D'OR, Geneva, Switzerland. Application filed November 9, 1888. Used since May 29, 1888. "The representation of a straight arrow."

399,006—MACHINE FOR CUTTING AND POLISHING PRECIOUS STONES, Etc. THEODOR BLUNTSCHLI, Schaffhausen, Switzerland. Filed December 30, 1886. Serial No. 223,021. (No model.) Patented in France July 1, 1886, No. 177,126, and in Germany July 4, 1886, No. 39,311. This machine consists of a grinding disk in combination with a frame perpendicular to the disk, carrying the tool stock and tool to hold the gem. The frame is so constructed as to allow of its being thrown out of perpendicular in order to adjust the tool, which is independent and has a spring-pressed cam lever. This device is also adapted to grinding tools.

399,128—SELF-WINDING ELECTRIC CLOCK. FRANK W. BRAINERD, Chicago, Ill. Filed May 25, 1888. Serial No. 275,043. (No model.) In combination, an electro-magnet with armature and pawl moving together.

Issue of March 12, 1889.

399,606—WATCH CASE. CHARLES K. GILES, Chicago, Ill. Filed December 2, 1885. Serial No. 184,532. (Model.) In this watch case the plain wide band or case body is externally threaded at each edge, and is provided with a pendant and an internal seat at its front edge, in combination with a back cap, which is provided with an internally threaded flange projecting beyond the periphery of said body, and a bezel provided with a like internally threaded projecting flange, and an inwardly projecting flange extending inward over the seat of the body.

399,603—JEWELRY CASE. CHARLES F. DOMANN, Lake View, assignor to William Reetz, Chicago, Ill. Filed August 21, 1888. Serial No. 283,384. (No model.) This jewelry case is composed of a base with two lids hinged thereto, link bars pivotally connected with each other and also with the lids, a cross bar carrying a frame that projects through the lids to admit of a handle to carry the case, and of rods for guiding the frame.

399,449—HANDLE FOR UMBRELLAS, WALKING CANES, Etc. WILLIAM TAYLOR, Buffalo, N. Y. Filed August 4, 1888. Serial No. 282,017. (No model.) In the handle of a walking cane, umbrella, etc., the combination, with the head of a shell having a cover, a central pin, a magnetic needle, these forming a compass, and a lifter provided with a suitable handle to admit of repairing, adjusting, etc.; also the combination, with the central portion of a core and a storm glass, retained in position by the elastic cushions, said portion having a longitudinal slot, these points admitting of and composing the parts of a thermometer, as and for the object stated.

399,450—EYE-GLASS POLISHER. EDWARD E. THORPE, New York, N. Y., assignor to himself and Harry Robinson, same place. Filed November 8, 1888. Serial No. 290,282. (No model.) This polisher consists, essentially, of an outer backing or body, an inner sheet of polishing material, as chamois, connected to the backing or body, and an interposed layer of viscid material.

399,542—OPERA OR MARINE GLASS. WILLIAM MACK, Terre Haute, Ind. Filed July 17, 1883. Serial No. 250,163. (No model.) The inventor has here combined in an opera glass or marine glass, a cross or yoke piece,

with a vertical socket, sleeve or clamp having a lower open end, and transversely located upon and secured to or formed with the cross piece, and adapted to receive and hold the end of a detachable handle for the glass.

399,543—OPERA GLASS HOLDER. WILLIAM MACK, Terre Haute, Ind. Original application filed July 17, 1888, Serial No. 280,163. Divided and this application filed November 7, 1888. Serial No. 290,229. (No model.) We have here an opera glass holder comprising telescopic sections, the section at one end serving as a handle, and the opposite end section longitudinally bifurcated forming spring legs or arms, which are softened and adapted to be removably secured to a tube, socket or clasp a cross piece of a glass, the inner ends of said sections being provided with exterior and interior intermeshing corrugations and outwardly springing end.

Issue of March 19, 1889.

399,647—REPEATING CLOCK. ARCHIBALD BANNATYNE, Waterbury, Conn., assignor to the Waterbury Clock Company, same place. Filed December 21, 1887. Serial No. 258,591. (Model.) In a clock, the combination, with a strike train, of a time train, a striking cam actuated by a time train and releasing the strike train, a striking hammer, a chiming hammer, a hammer wheel driven by the strike train and operating first one hammer and then the other, and a chiming cam actuated by the time train and cutting out the chiming hammer from the hammer wheel, and releasing it for operation thereby.

399,655—WATCHMAKER'S AND JEWELER'S PLIERS. JOSEPH DANIELS, Cleveland, Ohio. Filed October 31, 1887. Serial No. 253,839. (No model.) The inventor has here constructed pliers with the lower jaw having a sharp-edged end diagonal to the sides of the bony part and longitudinally corrugated, and the upper jaw constructed to touch the lower one only at its extremity, and both jaws curved laterally and downwardly.

399,725—ALARM CLOCK. ARCHIBALD BANNATYNE, Waterbury, Conn., assignor to the Waterbury Clock Company, same place. Filed July 16, 1887. Serial No. 244,500. (Model.) In an alarm clock, the combination, with the time train thereof, of a sleeve cam carried by a wheel driven by such train, an independent rotatable set staff extending through such cam which rotates around the staff, and a flat collar having a finger projecting from its edge in the same plane therewith, such collar and finger being made from one piece of sheet metal and the finger bearing flatwise on the edge of the cam.

399,824—CARD FOR BUTTONS OR STUDS. CHARLES G. BLOOMER, Pawtuxet, R. I. Filed December 21, 1888. Serial No. 294,267. (No specimens.) This card for holding buttons or studs in a uniform position, consists of a back, having a series of button holes, in combination with a rotary movable disk pivoted thereto and having a slot in the circumference thereof movable into position corresponding to each of the button holes.

399,840—WATCH CASE BOW. JONATHAN H. COOPER, Marshall, Texas, Filed August 25, 1888. Serial No. 283,707. (No model.) This invention consists of a watch pendant in combination with a radially projecting annular bosses or flanges, provided with radial threaded openings and set screws, and secured to or formed with the pendant and located diametrically opposite on the periphery of the pendant, a watch bow having its ends provided with annular grooves and loosely fitting in said bosses, so that the grooves will also be located in the same.

399,861—FASTENING FOR WATCH BOWS. FRANK G. FAXON, Mount Morris, N. Y. Filed August 15, 1888. Serial No. 282,790. (No model.) The combination of the bow having spheroidal headed ends, and a pendant horizontally divided in two, whose members are relatively adjustable to bring them in closer relation for taking up wear, and are held together by means of a nut screwed to a sleeve running through said pendant.

399,892—EYE SHADE. THOMAS H. HARRISON, London, England, assignor of one-half to Levy, Dreyfus & Co., New York, N. Y. Filed December 19, 1888. Serial No. 294,094. (No model.) This eye shade or protector consists of a main part or body formed of larger eye parts, these parts being connected by a bridge piece having a rearwardly-bent nose rest, and a retaining device for attaching the protector to the head.

398,987—WATCH REGULATOR. CHARLES TESKE, Hartford, Conn. Filed April 26, 1888. Serial No. 271,839. (No model.) The inventor here combines with the regulator arm of a watch, a fixed bar having on its body portion a downwardly projecting longitudinal rib, the traveler block with the body portion slotted transversely and fitted to slide on the ribbed portion of the fixed bar, the inner end of the block being fitted to receive the end of the regulator arm, and the outer end being perforated, and a disk journaled in the perforation at the outer end of the block, and with its perimeter in engagement with the outer edge of the fixed bar.

18,963—MIRROR FRAME. HENRY BERRY, Shelton, Conn., assignor to the Derby Silver Company, same place. Application filed February 16, 1889. Serial No. 300,172. Term of patent, 7 years.



[FROM OUR SPECIAL CORRESPONDENT.]

ATLANTA'S COMING EXPOSITION.

ATLANTA, March 18, 1889.

Atlanta is to the front once more in the way of an Exposition. The stockholders of the Piedmont Exposition Company met last Saturday in the Chamber of Commerce, and decided to hold a great exposition here this fall. It has been just a quarter of a century since Sherman brought his army over this part of the country and razed everything to the ground. It is the intention of the directors to celebrate this event in a fitting way, and thus show to the people of the United States the progress the South has made and the things she is reaching out after. It no doubt will be a great celebration, and one that will do not only the South good, but the whole country.

President Harrison has consented to be present, as the occasion will be one of much interest to him inasmuch as he commanded an army 25 years ago on the very spot where the exposition buildings now stand. A committee has been appointed to go to Mexico and invite President Diaz. It is thought he will come, as he is to be in Washington City anyhow this fall. Great preparations are being made, and from the present outlook it is safe say that an exhibition of the South's resources will be made here that has never before been equalled, and that will do immense good.

It seems that the tide of immigration will be southward before long. Capital is coming whether the people do or not

It is a wonder to me why some one does not establish a large wholesale jewelry house in Atlanta. The field is an inviting one, and I think offers many inducements for this business. True, we have several good houses here. A. L. Delkin & Co not only wholesale, but are doing a good deal of manufacturing. They are considered a thoroughly reliable house and have the confidence of the people generally.

The jewelry trade has been rather slow this month. March is somewhat of an off month in this clime, and the month so far has been no exception to the rule. It should be stated that a better line of goods is carried by our merchants than formerly, and while this may not show an increase in trade it does argue well for the people generally. Several of the jewelry merchants have taken advantage of their present quiet trade to re-model their stores and prepare for the spring trade.

T. J. K.

CARE, WORRIMENT AND UNREST.—Look around you in the cars, in the theatres, in the churches, on the streets, how many, many men and women do you see the lines on whose faces betray worry and unrest? A man is worried because he can't make more money; woman's heart is eaten up with envy because her next door neighbor dresses better than she is able to do; the inner nature of the dude is stirred to its foundations because the new moustache forcer fails to show signs that it is doing its promised work; the young woman's heart is burning up with jealousy at the success of her rival, and so on through all classes of people in every grade of society. Now, care and worry are deadly enemies to long life and happiness. No man can hope to live long, or to be even moderately happy, unless he makes up his mind to give scant welcome to these persistent visitors. He must learn to accept situations which he cannot avoid. He can do it. Let him make up his mind in early manhood to cultivate good nature, to believe in the idea that whoever does his duty will find that "There is a divinity that shapes our ends, rough hew them how we will."—*P. T. Barnum in The Epoch.*

The Adjustment of a Cylinder Watch.

By W. D—R, IN *Allgemeine Journal der Uhrmacherkunst*.

[The repairer at the bench will quite often meet with cylinder watches coming to him for repairs, and although the good workman should and does readily understand the principles on which every watch movement is constructed, as well as its good or bad condition, nevertheless he will meet with a cylinder movement less often than with a detached lever, and an occasional hint in the columns of THE JEWELERS' CIRCULAR, pointing out how this, that or the other ailment to which watches are prone is corrected best, may not come amiss. It is an undeniable fact that, be the repairs of a watch executed with never so great a skill, doubts and misconfidence as to the repairer's ability will arise in the owner's mind, should the watch not go correctly when returned to him. Only the correct performance of the repaired watch will satisfy him that the watchmaker is a skilful workman, and the explanations about "shop rate" and "pocket rate" of a watch will be understood only by an intelligent man, which, be it remarked parenthetically, not all men are, although they may wear and own watches. With these trite observations as precursors, we begin the translation "How to Time a Cylinder Watch."—ED.]



GOOD ADJUSTMENT of any watch requires first that it is in a good condition; that the depths are right, that no buttings or scrapings occur, that the mainspring develops freely, etc.; but the watchmaker's principal attention must be directed toward the balance motion and balance spring. The description of the escapement and its requirements is at present foreign to this article—we simply wish to remark as regards the cylinder movement—the escapement must stand neither too deep nor too shallow, and the weight of the balance must

be in a correct proportion to the power of the spring.

The magnitude of the angular motion of the balance, with a correct depth of escapement, is generally marked upon the plate in the vicinity of the stud by three dots, which may generally serve as guide. Should there be none or should they not be found to be correct, either make others or examine the performance as to the quantity of repose. The linear magnitude of the balance motion for the purpose of making the dots is determined in the following manner:

The magnitude of the angular motion (amplitude) of the balance, together with repose and lifting of the cylinder, to the two sides, amounts together to 40° ; therefore, the linear motion is equal to the chord of the arc of 40° , and this chord is the double sine of the half angle. The sine function of the angle of $20^\circ = 0.3420201$; but for our calculation suffice only two decimals, or 0.34. This number, when multiplied with the radius of the balance and doubling the product, gives the linear magnitude of the total motion of the balance toward both sides. The following simple example is for the benefit of readers unacquainted with trigonometry. Let us suppose that the diameter of the cylinder balance = 16 millimeters; the radius, therefore is 8 mm. Multiplying the function 0.34 by $8 = 2.72$; by doubling this product we have 5.44. For a diameter of 16 mm., therefore, the magnitude of the balance vibration toward one side = 2.72 mm., and together 5.44 mm.; these quantities, therefore, are to be marked by dots in the vicinity of the stud.

If anyone wishes to accomplish his object without paying heed to these dots, he may simply ascertain the quantity of repose in the following manner: Slowly lead the balance so far that the scape wheel tooth falls on the interior cylinder side; it is obvious that a small moving power, the spring or the hand, must thereby operate upon the train. When the tooth has laid itself on the cylinder side, or, better said, fallen upon repose, examine the quantity of this repose by conducting the balance now carefully toward the opposite direction, and noticing how far this must be led until the lifting by the tooth begins. If the motion is correct and the scape wheel truly round, then the motion of the balance, quoted in above calculation at 16

millimeters in diameter, from the drop of the tooth on the interior cylinder side to the beginning of lifting, with a repose of 6° , amounts to only 0.8 mm. With an untrue scape wheel the shortest tooth must still fall on repose; consequently the escapement must be somewhat deeper. These hints will suffice in order to hit the correct depth of the escapement; it is simply necessary to add that too shallow a motion, therefore, when the tooth does not at all drop upon repose, but at once upon lifting, is audible by a peculiar knocking noise, to which the repairer must listen when he examines a watch.

Concerning the balance, the weight of which must stand in a correct proportion to the power of the spring, the following may be remarked: Too light a balance is too much influenced by the changes in the spring force, which result from the impossibility of making so small a mechanism with mathematical precision. By an increase of the power of the spring the motion of too small a balance is accelerated, by a decrease it is retarded, and such irregularities of the rate, it is evident, do not permit a satisfactory adjustment.

But too heavy a balance, in consequence of its interior vital strength, is little or not at all influenced by these changes, but it has the disadvantage that the watch starts with difficulty, can be easily stopped and retards in hanging. The question occurs next, by which signs may be known whether a balance is too light or too heavy, or is in correct proportions, and how can these errors be corrected in whole or in part without replacing the balance and balance spring?

Too light a balance, if the proportions of the escapement are correct otherwise, will start at once, when the spring receives the first active tension force by the winding; it will also vibrate at once its greatest amplitude, and this error is essentially corrected by putting in a weaker spring. The too heavy balance will either not at all begin to move or only when the spring has attained to its fullest tension force, and in hanging the watch will retard to an important degree, if it was timed for lying. In this case replace the spring by a stronger.

The balance which, in its weight, stands in correct proportion to the spring force, will start at medium tension force—that is, without shaking the watch, when the second coil has been wound. The correct balance will furthermore not assume at once its greatest amplitude, but reach it only by degrees, which may be observed with the magnifier.

A third important factor for the good rate of a watch is its balance spring, a fact unhappily neglected by many watchmakers. It must first of all not be scraped, corroded, or bent or pressed out of shape in any degree. The stud must be exactly in the center, so that the coils run steadily and concentric to the center, when the spring is revolved upon the cylinder or upon an arbor in the double caliper. If the coils do not revolve truly or strike out to one side, then this would indicate that the spring would, when mounted in a watch, exert a side pressure upon the pivots and influence the operation of adjustment. The spring must also lie flat and parallel to the balance and the curb pins must stand vertically to the plane of the spring so that the full blade can strike on the pins, and not, as is the case with obliquely standing pins, strike only their upper and lower edges. Finally the outer coil must in its rounding correspond to the circular motion of the curb pins (a fact often neglected), so that this coil always stands free in the middle of the pins when the balance stands in a natural position of repose, no matter whether the regulator is pushed to "advance" or "retard." This coil is laid by mounting the spring (without cylinder) upon the cylinder bridge, turning the regulator to "retard," and placing the spring in such a position that the coil stands only a very little distance away from the inner curb pin. Now, push the regulator forward by degrees, and bend the coil in such a manner that the distance of the spring from the pin is always the same. Then lay also the other part of the spring so that the pivot hole stands exactly in the center of the stud.

Again, the thickness of the jewel holes is to be examined. Unduly thick jewel holes cause difference of rate between the horizontal and

perpendicular positions; they must either be replaced by new or corrected. This correction of the jewel holes is done with a copper chamferer, and diamond powder (not to be mistaken for diamantine) mixed in oil. (In Germany) this diamond powder can be had by every watch material dealer; there are three numbers—Nos. 1, 2 and 3; No. 1 is used for grinding, No. 2 for first polishing and No. 3 for fine polishing. The correction of the hole jewel is continued until the hole is as thin as the length of the pivot. The sharp edge of the hole produced by the correction of the jewel is chamfered with a pointed copper chamferer by twirling the tool.

It must also be mentioned that the balance should not be equi-poised in the double caliper, but in a good equipoising tool with well polished jaws.

When by the due observance of these several points the watch has been mounted, try first the rate for occurring differences between hanging and lying. Should it nevertheless vary in rate in these two positions, the following remedy may be used: If the watch advances in hanging, slightly overpoise that part of the balance toward the pendant by taking out a trifle with a three-cornered chamferer on the opposite part. But if the watch retards in this position do the reverse, so that the overpoise comes downward. Of course, take out only *very little*, as it is better to repeat the operation than to do too much at once, and observe the effect. No special mention need be made concerning the regulating with the regulator.

TO ADJUST AN ANCHOR WATCH.

The remarks about the balance spring and jewel holes made when debating the adjustment of a cylinder watch, hold good also for an anchor watch; it is only necessary to enlarge upon the timing in the positions and temperatures.

The greater weight of the balance of an anchor watch causes a greater friction of pivots in the hanging of the watch, and the adjuster must therefore reduce this friction to an amount equal to that in lying, by flattening the pivots and increasing the friction in a horizontal position.

Commence timing with observing the rate of the watch in a lying position. The approximately close rate is effected by the regulator, which manipulation needs no description, this article being intended for experts; the last exact timing in lying is effected by the four so-called timing screws; should the watch retard, screw in two of these screws standing opposite to each other, but when it advances, screw them out a little—but be careful to do it cautiously—turn one as many turns as the other, otherwise the equipoise of the balance is destroyed. The correct rate of the watch having been established in this manner, try it in hanging. If differences are noticeable now change the equipoise of the balance a mere trifle; do it not, however, in the manner described for a cylinder balance, by chamfering, but by means of the timing screws, in such a way, however, that nothing is changed on the timing of the rate in lying; do it as follows: If the watch advances in hanging the balance must be overpoised above toward the pendant; but an overpoise below is required when it retards. If, by taking the pendant as starting point, lines drawn between the timing screws would form a cross (+), then in advancing the upper screw is to be drawn out a trifle, and the lower one screwed in by that precise quantity; if the watch retards proceed in an inverse manner; screw in the upper screw and draw out the lower and opposite screw. If the above mentioned lines form a sign of multiplication (×), treat the upper pair or the lower pair as described for the single screws.

Small differences of rates between hanging and lying are also corrected without disturbing the equipoise of the balance by altering the shape of the cone; this is for the purpose of increasing or lessening the adhering resistance of the oil.

When the watch is laid flat the balance sinks by reason of its

weight, so that the lower pivot rests upon the lower cap jewel; the cone (that part of the arbor passing over into the pivot) thereby comes closer to the oil sink of the jewel hole, and the friction is increased by the adhesion of the oil which enters between. The thicker the cone the greater this friction, and reverse; it is lessened or finally ceases altogether, according to the degree of tapering of this part of the arbor, and herein do we possess a means of equalizing small differences of rate between hanging and lying. If the watch retards in lying its rate in lying must be retarded somewhat, which is done by increasing the friction by adhesion, moving the cone closer to the oil sink of the jewel hole—in other words, by shortening the two pivots to enable the cone to sink deeper in. The expert watchmaker will understand to find the true quantity to be removed by careful manipulation and examination of the rate. If, however, the watch advances in hanging, its rate in lying must be accelerated by diminishing the friction by adhesion; this is done by grinding more or less tapering with an iron grinding file the conical shoulders, according to the quantity of the difference of rate observed.

Regulating in the temperatures.—It is a well-known physical law that heat expands bodies while cold contracts them; the balance spring, naturally, is also subject to this law. An increase of the temperature lengthens, and, at the same time, weakens, the spring, causing a retardation of the watch; in cold it contracts, its elasticity increases and the rate of the watch is accelerated. In order to compensate these influences of the temperature, a specially constructed balance, the compensation balance, has been gotten up. It consists of two rims or parts. The inner part of the rim is of steel, and the outer part, which is of brass, twice the thickness of the inner, is melted on to the steel. As brass expands more than steel, the effect of an increase of temperature is that the brass, in its struggle to expand, bends the rim inwards, thus practically reducing the size of the balance. With a decrease of temperature the action is reversed. The action, which is very small at the fixed ends of the rim, increases towards the free ends, where it is greatest. The rim is cut, thus dividing it into two halves, each of which is free at one end and fixed at the other to the central arm.

As already said, the brass expands more strongly in heat than the steel, in consequence of which the rim bends inwards with an increase of temperature; the extreme part of the rim at the cut approaches toward the center of the balance, thereby making this smaller, as it were, and accelerates the motion, whereby the retardation produced by the balance spring growing weaker in heat, is counteracted or compensated. In cold brass contracts more strongly than steel, so that the rim expands and the extreme ends bend outward, thereby enlarging the balance and causing a retardation of rate, which counteracts or compensates the acceleration, which would occur by the increasing elasticity in cold of the spring. The extreme ends of these rims are the most active parts of the compensation balance, and their effectiveness increases with the division of the weight upon them and inversely; their effect decreases in ratio with the amount of weight taken off, and upon this occurrence is based the method of regulating the compensation. If a watch with compensation balance retards in heat and accelerates in cold the compensation is too feeble; more weight must from the main body of the balance be placed toward both ends of the rims; take out two screws standing opposite to each other and place them into other holes opposite each other, but lying nearer to the effective extreme ends. By this greater weight of the outer parts more weight is carried toward the center of the balance by the bending by expansion, and affects the retardation of the watch. If the watch accelerates in heat and retards in cold, then too much weight is carried to the center—the compensation is too strong; two screws, standing opposite to each other, must be moved away from the ends. When the difference is but trifling it suffices to file away a little from the cut, and to compensate the loss of weight by two other and heavier screws on the first parts of the balance.

The Marfels Watch Collection.

[From the *Deutsche Uhrmacher-Zeitung*.]

Continued from page 66, March, 1889

PART V.

IN FIGURE 34 is shown a watch with case not quite so richly ornamented as that described last, but it has a dial very artistically and ingeniously embellished. The watch is distinguished from all others in the collection by having its balance vibrating upon the dial. In order to protect the steel balance, the rim of which is set with garnets, against dust, the balance bridge upon the dial is covered with a small crystal in a bezel, and when the balance is in motion, the garnets upon its rim produce a charming effect.

The dial is ornamented with an exceptionally fine and handsome enamel painting, the subject of which is similar to that shown on the



FIG. 34.

dial last mentioned: a pair of lovers with a small dog, a symbol of faith. The arrangement of colors of this painting is so delicate and harmonious, that every connoisseur of enamel painting readily acknowledges it to be a most superb specimen.

The watch movement is in all its parts worked very carefully, and hermetically protected against dust by a silver ring around the two plates. The regulating mechanism lies upon the back plate, which



FIG. 35.

piece required a special contrivance, as the balance vibrates upon the dial.

An inscription upon the name plate says that H. Vernod, of Paris, made this watch; and the year of its manufacture is about 1790.

Fig. 35 shows the case of a so-called traveling watch, made in the second half of the XVIIth century. The bronze case of this piece

is not made entirely by hand, as we have seen by several previously mentioned in these columns, which were made by hammering, but it can be plainly seen that it was cast, and then finished by some skilful *ciseleur*. As will be seen in the cut, the central piece of the case swells out, is perforated and ornamented with various artistic embellishments in *cislé* work, which imparts to the case an agreeable appearance.

Concerning the movement, we wish to remark that it only shows the hours, but has already a balance spring, and strikes the time



FIG. 36.



FIG. 37.

every hour upon a bell. The tastefully engraved bronze dial of this watch is also worthy of notice.

In remarkable contrast to the above large verge watch stands the small gold cylinder lady's watch, shown in fig. 36. It was made by Flondeau, in Paris, about the middle of this century, and is not seen as large as some of the balance bridges of several of the specimens hitherto shown; it is so small and delicate that it could be worn as a charm on a watch chain.

The principal value of this watch is the differently colored enamel insertions in, and especially the small landscape in the center of the case. The dial of this watch is silver, engraved; the movement has been worked with great care.

The main feature of the very scarce and valuable specimen, fig. 37, is its handsome case. It is a lady's gold verge watch, dating to the last century; its movement possesses no distinguishing merits, but the case is worthy of being called a veritable specimen of artistic



FIG. 38.

production, being very highly ornamented in the colored style called by the French "a quatre couleurs." The whole case is completely covered with delicate gold inlays in the four different colors, each of which again is set with cut garnets. The middle piece of

the case is beside this ornamented by a highly tasteful and delicately executed garland representing flowers and fruits. Each of the many four-colored arabesques is isolated, and soldered on singly; every little jewel, also, is cut very carefully. From this it will be seen the great pains which the maker took to manufacture the piece.

The collection offers in an uninterrupted succession an infinite number of new and interesting pieces, well calculated to engage the visiting watchmaker's attention. In the preceding we described two very small ladies' watches; we next come to an artistically executed large traveling watch, one of which is shown in fig. 35. While the



FIG. 39.

case of this, however, is only partially made by hand, we find in the present specimen that it has been made all through in this manner—a characteristic which makes it far more valuable. The admirably chased bronze case of this watch, of which fig. 38 is a front and fig. 39 a rear view, is ornamented with artistically executed engravings and ciselations. As to be seen in the cut, the front side of the case is formed by a handsomely perforated cover over the dial, through the twelve cuts of which the lower figures are visible. The effect of



FIG. 40.

this peculiar disposition is still essentially increased by the excellent engraving of the cover. Fig. 39 shows that also the middle part and bottom of the case are perforated in a skilful manner.

The dial is bronze, like the case, and engraved and gilt. The movement, belonging to the end of the XVIIth century, and the maker of which is unknown, has no fusee, and is in all its part made

by hand. The watch shows the hour, similar to that described above; therefore it has only one hand—the hour hand—and strikes the hour upon a very loud sounding bell in the interior of the case. The greater part of the wheels are of iron, and several of them have 5-leaf pinions—a characteristic frequently found in the very old watches of this collection.



FIG. 41.

Generally speaking, watches with chased cases are no rarity, because many of them are found in certain districts, but nevertheless, really well shaped pieces are but seldom found, and lead us to conclude that very few such are in existence.

The greater number of the watches of this kind are either bad in design, or else very crude and superficially executed, and sometimes so badly worn that the higher raised places have lost all semblance of what they once represented.

The several specimens in the Marfels collection, therefore, are the more valuable, because their state of preservation is excellent, while their style of execution shows them to have emanated from



FIG. 42.

the hands of artists. To this, for instance, belongs the silver verge watch of the last century, shown in fig. 40. The design is executed upon the back part of the case, "Diana, while out hunting, surprises a sleeping shepherd." The single figures are nicely chased and partly sawn out; the whole makes a very harmonious impression. The name of the maker is to be seen upon a scroll at the lower part of the relief, "D. Cochin." A crystal in a bezel protects the group against wear.

A similar work is shown in fig. 41. It is a high English verge watch, dating to about the middle of the last century, and is provided with two cases; the interior case is smooth, while the exterior shows a very highly chased group, a few figures of which are 3 millimeters high above the bottom.

Although the design, representing an East Indian manner of salutation, is not as artistic as that of the watch described in the preceding, still, this want is compensated for by the very high chasing. The silver dial of this watch especially is worthy of note, because it is engraved so sharply and finely that it, of itself, makes the watch a veritable masterpiece. The movement, in common with the majority of the English watches dating to this time, is well worked, and carries upon the dial the name of the maker, "C. Leekey, London."

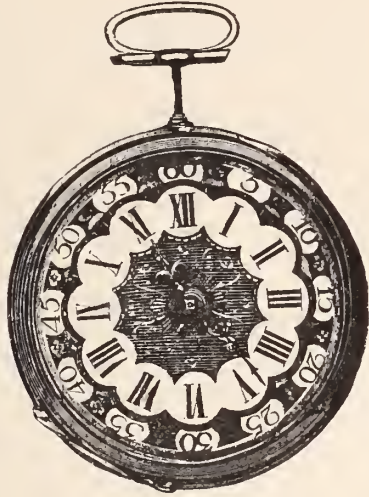

FIG. 43.

The collection contains another watch made by Cochin, the maker of the one shown in fig. 40, a silver, fire-gilt verge, shown in fig. 42. The chasing represents a scene in the Old Testament: Esther kneeling before the throne of the Persian king Xerxes, who makes her his spouse. The several figures are by a skilfully arranged group in a harmonious collection, and, like all the works executed by Cochin, are excellently well chased and clearly executed down to their smallest details. Similar as with the chasing shown in fig. 42, that of the watch under debate is also protected against wear by a crystal and bezel. The movement is made in the past century, and of French make, and possesses no special merits; it is somewhat



FIG. 44.

interesting, as it was made in the transition period from the high form to the flat.

It is a fact repeatedly reaffirmed in this collection, that in former times a far greater value was laid on the artistic embellishment and rich ornamentation of the dials than to-day, because the many silver engraved dials found on the watches of from the XVIth to the XVIIIth century are all ornamented in this manner. We show a gold verge watch in fig. 43, which departs from the usual routine by having two dials, one on the front, the other on the back. One is simply of white enamel, but the other is a masterpiece in the fullest meaning of the word. It is ornamented partly with gilt, and partly with differently colored enameled inlays, harmoniously grouped,

and all parts bear evidence that an extraordinary amount of care was expended in the making of the dial. The fancy hands are gold, fretted, and engraved, and in keeping with the style (Louis XV.) of the watch. The contrast between the gold hands and the enamelled and richly gilt inlays in their different colors produce a most charming effect. Nor has the movement been slighted in any respect, as, on inspecting, it will be found worthy of admiration. All its parts are of excellent workmanship. It is somewhat similar to the watch with decimal division formerly described, only with this difference that its two motion works are calculated for 24 hours.

An exceptionally handsome and very rare specimen—perhaps French work, is shown in fig. 44, a gold verge watch of the last century. The movement is comparatively simple, but so far as the case is concerned, a glance at the case will tell us that it is a masterpiece. The case in all its parts adorned with charming gold ornamentations in four colors (a quatre couleurs) leaf and flower arabesques on many places incrustated with garnets. The rim of the case is ornamented with especially fine *ciselé* flowers and fruits, while in the center of the case bottom six handsome garnets form a charming ornamentation, contributing to lighten the total effect. The whole makes in its different colors, its rich design and fine execution a very agreeable impression, and the watch may justly be called a masterpiece in the presence of so many. Its maker is not known. One fact speaks for the great rarity of watch cases of this kind: the writer of these lines has in the course of his life handled many hundreds of old watches, but he



FIG. 45.

does not remember that he has ever seen a second specimen similar to this. We next come to a lady's gold watch with a peculiar and striking ornamentation of case, the back of which we show in fig. 45. It differs from all those with enamel ornamentation, hitherto described. The crystal rim as well as the back case bottom, are each set into a bezel richly studded with turquoises and garnets. (In the accompanying figure, being a woodcut from a photograph, the turquoises are easily distinguished from the garnets—the former are of a pale color, the latter, of a dark.) Within the bezel, the case is ornamented with differently colored enamel and gold adornments, which, with their ingenious forms, recall the productions of the goldsmith's art of the XVIth century, and make this watch a production of art.

The movement contains no special features, still, it is worked well and has a finely executed gilt dial with soldered on enamel numbers. The watch is according to all appearance made in the last century; its maker is unknown.

HIS WATCH WASN'T INFLUENCED.—One of the great faults of the new electric cars has been found to be the influence of the accumulators on watches. Unless watches are constructed so as not to be subject to electric effects, they invariably stop, or at any rate perform some remarkable feats of timekeeping, while the owner takes a trip on the new vehicles. There was a case the other day, however, in which a man's watch was not affected. He jumped on an electric

car with a friend, and soon after a discussion began with the electric influence on watches as a subject.

"Does the accumulator affect your watch?" asked the friend, looking earnestly at the other's chain.

"Not in the least," was the answer

"Had it adjusted, eh?"

"Nope; but it doesn't affect it a bit."

"That's funny; I'll bet you haven't the right time."

"I don't know about the right time, but I'll bet my watch isn't influenced," he snapped, pulling out his chain, and displaying a pawn-ticket attached to the end of it. And his friend purchased the stimulants.—*N. Y. Tribune.*



* A Complete History of Watch and Clock Making in America.

[By CHAS. S. CROSSMAN.]

Number Thirty-Two.

Continued from page 62, March, 1889.

WATCH CASE MAKING.

CHARLES AND ELIASHIB TRACY AND THE FIRMS THEY WERE CONNECTED WITH.



CHARLES TRACY was born at Lisbon, Connecticut, in 1807. He came to New York and served an apprenticeship in the jewelry business, working for Palmer & Clapp. In the year 1830 he formed a partnership with Chas. Hulse, a practical watch case maker, for the purpose of manufacturing cases. They were located in Nassau street, near Fulton, and employed mostly Swiss help. They received their start in business through the aid of Hiram Tarbox, who kept a jewelry store in Nassau street and took most of their productions. The firm of Tracy & Hulse continued for about a year, when the partnership was dissolved. Mr. Tracy then continued the business in connection

with John L. Ward, who had served his apprenticeship in the same shop with him, and had afterwards been keeping a jewelry store. They failed in 1837, and Mr. Tracy then went to Philadelphia and entered the employ of Thomas Garrett.

In 1840 he and his brother, Eliashib, commenced to manufacture cases under the firm name of E. Tracy & Co. Eliashib was a younger brother. He had been in the jewelry business in New York City, but went to the West Indies and practiced dentistry after the panic of 1837 until this time. The new firm began in a small way in a room over the store of John C. Farr, a jeweler, at the corner of Chestnut street and Hudson's Alley.

In 1845 Mr. Farr put \$5,000 into the business and became a silent partner and the business flourished.

In 1850 the firm became C. & E. Tracy, but in 1853 they disagreed, and after arbitration they separated, and Charles Tracy

removed to Third street and Harmony Court, and formed a partnership with Samuel Shellcross, and the firm was Tracy & Shellcross. This partnership was of short duration, and the business was closed up and Mr. Tracy removed to Missouri, where he has since resided.

At the time of the separation of the firm of C. & E. Tracy, Mr. E. Tracy associated with him Mr. Theodore Baker, under the firm name of Tracy & Baker, and later, Tracy, Baker & Co., Mr. Royal E. Robbins, of New York, purchasing an interest. In 1857 the firm split again, owing to a disagreement which arose with reference to an investment which had been made by Mr. Robbins for the firm in the Dennison, Howard & Davis Watch Factory at Waltham, on which there was a mortgage for \$7,000. Mr. Robbins considered the purchase a necessary one, as this firm were indebted to them to the extent of some \$8,000 for watch cases. Mr. Baker being an expert accountant went to Waltham and examined the books of the company. He returned to Philadelphia in about three weeks and repudiated the arrangement, and withdrew from the firm, Mr. Robbins purchasing Mr. Baker's interest, amounting to one-sixth, and the firm of Appleton, Tracy & Co. was then formed, Mr. J. Appleton coming from Buffalo to take an interest and Mr. Robbins remaining as the company. The firm, however, did not own the watch factory at Waltham but a short time, as Mr. Robbins took it off their hands, and soon formed what now is the American Waltham Watch Company. Mr. Robbins and Mr. Appleton both withdrew from the firm of Appleton, Tracy & Co., and Mr. Tracy subsequently removed to 618 Chestnut street, where he finally sold the business to the Messrs. Hagstoz & Thorpe in 1876, thus ending his connection with the case business. Since then he has been interested in other enterprises, and now resides at Bryn Mawr, a suburb of Philadelphia, in a palatial residence.

WILLIAM TRACY,

Who has been intimately connected with the case manufacturing business for many years, was born at Lisbon, Connecticut, in 1803. He taught school for some time at Yonkers, N. Y., and in 1830 came to New York City to work for the firm of Tracy & Hulse, of which his brother, Charles, was a member.

In 1835 he became a member of the firm of Buckley, Preston & Tracy, formerly employees of Tracy & Hulse. They located at the corner of Fulton and Gold streets, and made mostly open face 18-k. and 16-k. cases. They also made some imitation pair cases. This firm failed in the panic of 1837.

In 1840 Mr. Tracy went to Philadelphia to work for E. Tracy & Co., and in 1848 he went to Boston to start the first case shop there for Samuel Way, but after remaining there a year he returned to Philadelphia, but did not again go into business on his own account. He still resides in Philadelphia at an advanced age.

C. JACOT & BRO.

This firm, composed of Celestine and Hector Jacot, at one time ranked among the most successful watch case manufacturers of Philadelphia.

The brothers came from Switzerland in 1825, and Celestine at once entered the employ of David Louis Huguenin, a countryman of his, who had previously established himself in the case business in Philadelphia. Subsequently he went to New York and worked as journeyman for Chas. Tracy.

Returning to Philadelphia in 1839, he purchased the business of Philip and Simon Paul, who had become Mr. Huguenin's successors in 1833. Mr. Jacot continued at the old stand on Market street, between Bank and Strawberry, formerly occupied by Huguenin and Paul Bros., until 1842, when he removed to 65 South Second street, four doors above Chestnut. He had two floors of the building as a factory and also took up his residence there.

In 1852 he took his brother, Hector, into partnership, Hector having been in his employ for some years. The firm then became C. Jacot & Bro. They were the first case manufacturers in Philadel-

phia to manufacture a low grade gold case in addition to their regular 14-k. and 18-k. goods. They built up a large trade in this grade of case. They commenced to manufacture oroide cases, but were not very successful in this and soon dropped it. They also made a patent reversible case in 18-k. gold which was quite popular. It was patented by a Mr. Durand in 1852 and assigned to them. This Durand patent case was considered an improvement on the regular style of "magic" case.

The firm was quite successful in business for a number of years and employed as many as fifty hands, which was considered a large number at that time. Business, however, began to decline. One of the principal reasons for this was owing to their connection with the Philadelphia Watch Co. This company had a charter to manufacture watches in Pennsylvania, but the watches were made in Switzerland and cased in Philadelphia. Hildebrandt & Bro. had the management of this company, and finally failed in 1871. Jacot Bros. found themselves heavily involved by this failure, as they had exchanged notes with and been endorsers for the Philadelphia Watch Co. to a large extent. It might be in place, however, to say that according to the best information, they were already nearing bankruptcy before this, as their business, owing to various reasons, had been taken by other firms. The failure of a New York house in 1871 who owed them a large amount, brought matters to a culminating point for the firm of C. Jacot & Bro. Probably to avoid the trouble of going through bankruptcy, they suddenly resolved to take up their residence in the Dominion of Canada, and acted at once on this resolution. As soon as it became known that they had left, the tools and machinery were seized by the sheriff and sold at public sale, and thus ended the career of one of the prominent firms of watch case manufacturers in Philadelphia.

HARPER & McCLELLAND AND HIBBARD G. GILL

Was the name of one of the Philadelphia case manufacturing firms that flourished about thirty years ago. The firm was composed of Thomas Esmond Harper, who had worked at case manufacturing for a short time with Simon Paul, and Daniel J. McClelland, who learned the case business with C. Jacot.

They were located at the corner of Dock and Walnut streets and commenced operations in 1850. They manufactured gold cases exclusively, and did for those times a large and prosperous business.

In 1857 Mr. McClelland retired from the firm. Mr. Harper then conducted the business alone until his failure in 1859.

Hibbard G. Gill, who had served his apprenticeship with Reese S. Peters, commenced business in 1864 at the corner of Dock and Walnut streets, having purchased the tools and machinery of the above firm at assignee sale, and continued the business.

He made at first a line of Swiss, English and American gold and silver cases, principally the latter, having but five employees. Business increased with him until, in 1875, at the time of his removal to 618 Chestnut street, he had fifteen employees and was producing seventy-five cases per week.

After locating at 618 Chestnut street he introduced the use of machinery in case manufacture, and gradually dropped the manufacture of silver cases, turning his attention to the manufacture of gold cases exclusively. At present he is carrying on a large and successful business at this location.

C. & A. PEQUIGNOT.

This firm is composed of the two brothers—Constant and Auguste Pequignot—the former having served his apprenticeship with Jacot & Bro., and the latter with Z. & G. Gigon. They commenced business on their own account in 1854 at 121 South Third street, and remained at that location until 1859, when a co-partnership was formed with Gustavus Gigon under the firm name of Gigon, Pequignot & Bro., and the business was carried on at the corner of

Dock and Second streets. The new firm pushed the business vigorously. They remained in this location until February, 1863, when they dissolved, Messrs. Pequignot removing to No. 22 South Fifth street, and subsequently to 925 Chestnut street, resuming the old firm name of C. & A. Pequignot. They were manufacturing gold and silver cases until 1876, when they discontinued the silver branch of their business and produced only gold cases. On January 1, 1884, the firm decided to discontinue this branch also, and give all their attention to the watch and diamond business.

LOW & COURVOISIER, AND SUCCESSORS

Messrs. Low & Courvoisier manufactured cases in Philadelphia for a short time, being located at 76 South Third street. The firm was composed of Mark Low, formerly a journeyman with Harper & McLean, and a Mr. Courvoisier, who had come from Switzerland at the age of sixteen to enter the employ of C. Jacot, in the capacity of spring maker.

They were in business a few years, commencing in 1854. They made gold cases only for Swiss and English movements. Mr. Low received a government appointment as night inspector, and the firm gave up the case business.

They were succeeded by Ducret & Leichty in 1855. Mr. Leichty had formerly been with C. Jacot. About 1860 the partnership was dissolved, and Mr. Leichty formed a partnership with a Mr. Chabot under the firm name of Leichty & Chabot, which soon became Leichty & Deschamps, and later Leichty & Co., B. Levy being the Co. at this time and furnishing the money. Mr. Levy had formerly been in business at Fifth and Market streets as engine turner and engraver.

The firm of Leichty & Co. occupied a shop at 140 South Third street, at the corner of Harmony Court. Mr. Leichty retired from the firm in 1878, and the business was carried on by B. Levy at the same location until 1880, when he removed to 402 Library street.

In 1880 Mr. Leichty formed a partnership with Peter Le Bouba, occupying the old stand at 140 South Third street, vacated by Mr. Levy. In February, 1884, this firm was succeeded by Theophilus Zurbrugg & Co., with which firm Mr. Leichty is now connected.

CROWELL & DUNKERLY—WAIT & CROCKER, SUCCESSORS.

This firm was composed of first David Crowell and Geo. Dunkerly. The former had been in the employ of Jacot & Bro. They flourished in Philadelphia for about a year and one-half, being located in Pear street below the Farquar buildings. They commenced operations in 1855 in a small shop, and made principally gold cases of finest quality.

George L. Wait, who had been with the Messrs. Tracy, bought out the business of the above firm in 1856, and found a moneyed partner in 1858 in the person of Lemuel L. Crocker, who fitted up a shop in the Schuylkill Navigation Co.'s building on Walnut street. Here they carried on a successful business for about four years, making solid gold cases only, and employing from thirty to forty hands.

The war of the Rebellion was the cause of their shutting down in business, as was the case with many other firms. Mr. Crocker went into the army as captain in 1862, and as he was the moneyed man of the enterprise, Mr. Wait was obliged to give up the business.

VAN TRUMP & SILVER

Carried on a small case business in Baltimore, Md., beginning in 1856. The firm was composed of John Van Trump, who had formerly been a gunmaker, and David Silver, who had been a carpenter.

Their business was never a large one, and times were poor for business. They did mostly repairing of cases, but also made some cases for English movements. They commenced to make cases for

American movements when the war broke out, and brought business to a close in 1861.

Mr. Silver, now an old man, has been until recently in the employ of Booz & Co., of Philadelphia.

JOHN HENRY

Was an apprentice with Constantin Jacot, and afterwards worked for Reese S. Peters in Pear street for a short time. In 1856 he started in business for himself at Second and Gold streets, carrying on business for about four years. He failed in 1860, and the sheriff sold out the business, which was purchased by Jacot & Bro.

(To be Continued.)



[FROM OUR SPECIAL CORRESPONDENT.]

PHILADELPHIA, March 20, 1889.

Business in the Quaker City is in the usual transition stage. Lenten dullness is upon us, and dullness is something that the jewelry trade, fortunately for them, never can get accustomed to. Consequently there is much complaint. But inquiry among the prominent wholesale and manufacturing firms convinces your correspondent that business in the jewelry line is not much slower than it was last year at this time. So far as news is concerned, this is the result of an activity and bustle that cannot be expected now, and barring the purchase by H. Muhr's Sons from the estate of Joseph Muhr of the entire good will and plant of the latter, almost nothing has occurred to the set the gossips agog. This transfer, accomplished on the 15th through the courts, restores to the firm of Muhr the ring and thimble department of their business, which at the time of the dissolution were taken by Joseph Muhr. They will now resume the manufacture of these goods, in which they previously achieved such success. Mr. Rowbotham will probably re-enter their employ. Simon Muhr reports unusual activity in their case factory. So great has the demand become for both filled and gold cases of their make that they now do an order business solely and have discontinued carrying stock.

David F. Conover & Co. were reasonably busy and content when THE CIRCULAR'S representative called, a contentment which was explained by their statement that trade was good for this season and failures were few.

Simons, Bro. & Co. are on the up move and report a constantly increasing business.

I. Bedichimer, maker of masonic marks and emblems, 616 Chestnut street, has about 1,000 tiger claws on hand for jewels of the mystic shrine, a specialty in which he is gaining an enviable reputation. He has a great variety of these handsome jewels, from the plain symbols to the elaborate, richly ornamented jewel.

James W. Queen & Co. have moved from their temporary quarters at No. 927 Chestnut street to their new store on the opposite side of the way, No. 924. Their salesroom runs clear through to Sansom street, and is unquestionably one of the largest and finest optical establishments in the world.

Mr. Schober, of the National Watch Case Co., 715-717 Arch street, looked very wise and mysterious on being interrogated, and murmured some inaudible remarks about a little novelty they were getting ready to show the trade, the precise nature of which he could not be persuaded to divulge, however. He promised to be more explicit later.

W. J. Atkinson, of Atkinson Bros., wholesale agents for the Keystone watch, returned two weeks ago from California, whither he went in search of pleasure and business, and where he found both, if his appearance and the fact that they are unable to supply the demand for their dust-proof watches are a good criterion. This young house has pushed ahead with commendable energy and pluck. In the short space of three years they have managed to build up a large and rapidly growing business. Push, good judgment, honorable dealing and courtesy have done it.

Jacob Bennett & Son are now fully settled in their new quarters at 1,024 Chestnut street, over Blank's confectionery. They occupy the three upper floors, the second for their offices and polishing room and the third and fourth for their shop. The fitting up is in the highest style of art for elegance and convenience, and the result of this improvement is already apparent in the increased business which the firm has enjoyed ever since its removal.

Philadelphia opticians seem to be pretty busy, and of these none is busier than M. Zineman & Bro., 130 South Ninth street, manufacturers of the celebrated Diamanta eye-glasses and spectacles. These goods are becoming deservedly popular, and, as an evidence of the success that is attending this house, M. Zineman has recently purchased a fast horse which he has named "Specs," in honor of the Diamanta brand. He says the horse doesn't go nearly as fast as the glasses do.

Gautschi & Son, importers of musical boxes, 1,030 Chestnut street, are about to engage more extensively in the wholesale business, and are now in the midst of repairs and renovations.



[THE CIRCULAR is not responsible for the opinions or statements of contributors, but is willing to accord space to all who desire to write on subjects of interest to the jewelry trade. All communications must be accompanied by a responsible name as a guarantee of good faith. No attention will be paid to anonymous letters. Correspondence solicited.]

FROM OUR HELPERS.

Lyons, N. Y., March 4, 1889.

To the Editor of the Jewelers' Circular:

Enclosed please find check for \$2 for THE CIRCULAR for one year. Also please send the advance sheets of "A Lady's Rambles Among the Jewelers," as we have made arrangements with our local papers to publish them. We thought we would try a weekly publication, but we can hardly do without THE CIRCULAR, having taken it so long.

Yours resp'y, HOFFMAN & ROBINSON.

A NEW "OLOGY" NEEDED.

Chicago, Ill., March 10, 1889.

To the Editor of the Jewelers' Circular:

Will you kindly inform me in your next issue whether there is any general term ending in "ology" that covers the subject of precious stones or gems?

Yours sincerely, T. D. BROWN.

[Apparently there is no "ology" or general term for the "study or science of gems or precious stones." It must be called the study of precious stones, which form a part of mineralogy.

The Greeks called a precious stone in its native state either *lithos*, a stone, a *psephos*, a pebble, while an engraved stone they called *sphagis*. Any word covering that science to be a good coinage would, if compounded with "ology," require to be compounded with one or other of these three. Lithology, as the "natural history of stones," is already pre-empted, while petrology and petrography

THE WATERBURY WATCHES.

THE NEW SHORT-WIND "SERIES J."



LONG-WIND, "SERIES E,"

SHORT-WIND, "SERIES J,"

AND

THE LADIES' WATERBURY, "SERIES L."

THREE SERIES!

THREE STYLES!!

Send your Orders to

THE WATERBURY WATCH CO.,

GEORGE MERRITT, GEN'L AG'T,

92 & 94 Liberty Street, New York.

denote certain geologic departments concerned with the chemical constitution of rocks. In the Century Dictionary lithoglyphics is used for gem sculpture, or gem cutting and gem engraving, while glyptics glyptognoc, glyptography, glyptology, refer to the art of engraving precious stones, the knowledge of engraved stones, the science or description of engraved stones or the engraved stones themselves. Dactyliology is the science of rings, especially with reference to the stones in them, which were called by the Romans gemma or buds, because of their resemblance to the bursting buds.

A comprehensive term for that branch of the study is, therefore, still a desideratum.—GEORGE F. KUNZ.]

IS THIS A CHIRIQUI ORNAMENT?

San Francisco, February 14, 1889.

To the Editor of the Jewelers' Circular:

Enclosed find drawing of a gold charm which I have as a curiosity. I received it about three years ago from an Italian. It is of solid gold about 20-k. fine, is $\frac{1}{2}$ larger than drawing, and weighs $13\frac{1}{2}$ dwts. From descriptions in THE CIRCULAR of November, 1888, No. 3 (under heading "Use of Gold and Other Metals in Ancient Chiriqui"). I think it is some of their work. Would you please be so kind as to let me know about what such a charm is worth as a curiosity?

Yours resp'y, FRANK GRUNER.

[Your charm is worth from one to three times the value of the gold; just how much it is impossible to say without examination.—ED.]

BACK NUMBERS TO BUY AND TO SELL,

[Those having any of the numbers called for here should communicate with the correspondent direct, unless the call comes from abroad, in which case the copies should be sent to THE CIRCULAR office to be forwarded.]

Preston, England, February 21, 1889.

To the Editor of the Jewelers' Circular:

I am in receipt of yours dated February 8, for which accept my thanks. I shall be very glad if you will try and procure the back numbers of your journal for me under head of "Communications." Enclosed find paper dollar as a guarantee of good faith. Kindly insert at your earliest as the other numbers are at the binders waiting for completion. Covers and advertisements can be torn off to reduce carriage or postage. 1877, October; 1879, January, February, August; 1880, July; for these five numbers I will give three times the published price. 1882, February, April, July, August; 1883, January, June, July, August, September, October; 1884, December; 1885, July, August; 1886, June, July, November; for these sixteen numbers I will give the published price. I have the following 31 numbers of THE JEWELERS' CIRCULAR AND HOROLOGICAL REVIEW to spare. They are duplicates of what I have. Will sell any or all at half price: 1876, November; 1877, February, July, August, December; 1879, October; 1880, June, November, December; 1881, February, April, May, June, July, August, September, November, December; 1883, November, December; 1884, January, March (2 copies), May, June, July, August, September, October, November; 1885, February. Thanking you in anticipation, I am, dear sir,

Yours faithfully, JAMES JOHN BRAMWELL.

Gloucester, Mass., March 4, 1889.

To the Editor of the Jewelers' Circular:

Will you please send me the following numbers of THE JEWELERS' CIRCULAR: July, 1888, No. 6, July, 1886, January, 1886, and February, 1889. I want to make a book and these are some I never received. Please send as soon as you can.

Yours, etc., ROSCOE V. HURD.

Pine Bluff, Ark., March, 14, 1889.

To the Editor of the Jewelers' Circular:

In response to the call for back numbers in your last issue, would

say I can furnish you with the August, 1879, number asked for by J. J. Bramwell. Would like to get numbers for June and July, 1886, and the complete volumes from 1875 or 1876 to 1883, containing the complete series by "Excelsior." Also have the following old numbers to spare: January (2), 1883, February, 1884, February, 1885, September, 1885, May, 1885, August (2), 1886, November, 1882, December, 1882.

Respectfully yours, SIDNEY SMITH.

Moorefield, W. Va., March 18, 1889.

To the Editor of the Jewelers' Circular:

Can you furnish us a copy of THE CIRCULAR of Oct. 1883? Want to complete our book, for binding.

J. BEATTY & SON.

UNSOLICITED TESTIMONIALS.

Cheraw, S. C., March 12, 1889.

To the Editor of the Jewelers' Circular:

Enclosed find two dollars for THE CIRCULAR for this year. I waited until now, thinking that I would quit taking THE CIRCULAR, but find it impossible for me to do so, as I have taken it so long I cannot do without it. I have been a subscriber since the first number was issued more than 19 years ago. I have all the numbers and all the volumes up to the present time. I have concluded that it is the best journal of its kind published anywhere; therefore I cannot do without it. I hope it will long continue its usefulness to the trade.

Yours, etc., H. L. LOUGHLIN.

Helena, Mont., March 4, 1889.

To the Editor of the Jewelers' Circular:

Enclosed please find order for two dollars for my delinquent subscription to THE CIRCULAR, which is never-ceasing in its visits to me, and is always full of good tidings. Please continue the welcome visitor for another year. Thanking you for your kind indulgence with me, I am,

Yours truly, T. W. WARREN.

Aurora, Ontario, March 14, 1889.

To the Editor of the Jewelers' Circular:

You will see by the enclosed that my address is changed. Hope there will be no mistake, as I would not miss the paper for five times the cost. Please accept the amount for my renewal and oblige,

W. J. DUNN.

Bellefontaine, Ohio, March, 14, 1889.

To the Editor of the Jewelers' Circular:

Enclosed find P. O. money order for \$2 in payment of THE CIRCULAR for one year. I consider THE CIRCULAR the best journal of its kind published. I don't want to miss it.

C. A. MILLER.

Offerman, Ga., March 16, 1889.

To the Editor of the Jewelers' Circular:

Kindly find enclosed \$2 for my subscription to your invaluable paper. I like it better every day, and cannot comprehend how a country dealer can think of going without it, if he wishes to keep posted. I depend upon my papers for all my new goods, as it takes the place of the drummer's sample trunk, as the drummers cannot afford to visit the small towns. Every jeweler needs one or more papers, and them reliable, and yours is *AT*.

J. J. GIBBS.

Frasersville, P. Q., March 23, 1889.

To the Editor of the Jewelers' Circular:

Enclosed please find two dollars to renew my subscription. THE CIRCULAR merits all the good that is said of it.

Yours respectfully, I. A. SAVARD.

Obituary.

JOSEPH BURRITT.

Joseph Burritt, of Ithaca, N. Y., one of the oldest jewelers in the United States, died on Saturday, March 9th, aged ninety-three years and six months. He was born in New Haven, Conn., in 1795, and was apprenticed at an early age to a watchmaker and silversmith of the Elm City, a tower-clock of whose construction still marks the hours for the students of Yale College. This ingenious craftsman also made and repaired the mathematical, optical and nautical instruments for all the country round about as well as for New Haven itself, which, during the war of 1812, was the only neutral seaport in the northern states, and therefore a place of considerable importance. This Yankee teacher of Mr. Burritt's was a proficient workman in those good old days, when spoons were beaten out by hand, clocks, both wood and brass, were constructed by the same leisurely process, and a part of a watch, if broken or lost, could not be ordered by size and number from a factory as in these days, but had to be replaced laboriously by hand. While serving his apprenticeship Mr. Burritt, by permission of his master, made for himself an excellent set of tools, which he used for many years. Mr. Burritt completed his apprenticeship and his majority in the year 1815, and naturally cast his eye about for a desirable place in which to ply his craft. In the following year, therefore, our young journeyman bought a horse and wagon, and taking his wife (for he had married in the meantime) and the tools of his trade, in company with another journeyman silversmith named Fairchild, of Stratford, Conn., he set out for the new land beyond the Hudson, of which vague rumors had come to him while he was learning his trade. It was a ten days' pilgrimage overland to the little hamlet which marked the site of the present flourishing village of Ithaca. Deer, startled from the thickets, leaped across the road in front of the hardy pioneers. A score of rude duellings constituted the village of Ithaca at that time, and it was no easy matter to secure a home or a store in such a settlement; but Mr. Burritt finally succeeded in obtaining a room on the second floor, and started to work. When he left Stratford he intended to settle somewhat north of Ithaca, but by the advice of a friend who informed him that there was no craftsmen of his order in Ithaca, he decided to stop there. He found, however, that there was a silversmith named Burdick, in town, who was doing quite a brisk business, and his companion Fairchild growing homesick, he entered into a partnership with Burdick, which was continued almost uninterrupted for twenty-five years. They had all the work they could attend to till far into the night. In 1838 Mr. Burritt's son, Joseph C., was made a partner in the business. After fifty years of success, just before the late war, Mr. Burritt retired from business, at the solicitation of his friends, disposing of his interest to his son and partner, who has since conducted the business either alone, as at present, or in connection with others, who have since established stores of their own. With very few exceptions the watch repairers of Ithaca and adjoining towns acquired their knowledge of the craft from Mr. Burritt, and all unite in testifying to his ingenuity and thorough workmanlike qualities. Though ninety-three years of age last August, Mr. Burritt was remarkably well preserved. He used no glasses, artificial teeth, or ear trumpet; his step was firm, his eye bright, and his mind clear. Until within a few years past he had had a workshop above the store, where he passed regular hours of labor every day. With advancing years, however, came the tremulous hand which refused longer obedience to the will, and he finally trusted himself to do only the coarser grades of clock-work. His regular attendance at the familiar place of business, on State street, became second nature, and he might have been seen there every day, newspaper in hand. In his habits he was very temperate and methodical, which probably accounts in part for his great longevity. One of the few paralleled instances of longevity in our trade is that of the Foster Brothers, Newburyport, Mass., who retired from business about three years ago at the age of nearly ninety, after a partnership

extending over a period of more than sixty years. By dint of industry and economy our aged jeweler had been able to amass a fair competence, and, to the day of his death, was the oldest man in Ithaca, and was respected by all his fellow-townsmen for his many sterling qualities.

JUSTUS KRUCKEMEYER.

At 10 o'clock on Thursday, March 7, Justus Kruckemeyer, foreman of the silver department in Duhme & Co.'s establishment, Cincinnati, departed this life. Mr. Kruckemeyer was born April 21, 1841, at Essen, Germany, and at the age of 19 years, with his brother Louis, left his home to seek his fortune in America. He found employment at Duhme's, where he served till the war when he enlisted in the 165th Regiment. He afterward returned to his old employers, where he served till his death. He was a charter member of the North Cincinnati Turn Verein. A widow and five children survive him.

MRS. ALINE GUEDIN.

Many of the older members of the trade will be sorry to hear of the death of Mrs. Aline Guedin, which occurred on the evening of March 10, at her late residence, 211 East 15th street. In her death the reminiscent will bring to mind the respected figure of Jacques Guedin, who was the senior member of the old-time house of Ve J. Magnin, Guedin & Co., in its day the oldest Swiss watch importing firm in the country, and who, during the term, 1876 to 1877, was president of the New York Jewelers' Association. Mrs. Guedin was the sister of Mrs. Lorenzo C. Delmonico, and as an evidence of the high regard in which she was held, fully two hundred friends were present at St. Ann's Roman Catholic Church, at which a requiem Mass was held for the repose of her soul. She died at the advanced age of 80 years.

New Method of Hardening Delicate Steel Parts.



THE WARPING of very delicate or long steel parts by tempering is one of the most disagreeable occurrences that can happen to a watchmaker, and many remedies have been proposed and are in use to counteract it, with more or less satisfactory results—tempering in animal charcoal, smearing with soap, tempering in the lead bath, etc. The latest method is that of the very able watchmaker, Mr. P. Gabriel, published in the *Revue Chronométrique*. He says:

“Take an earthen or metal crucible, pour in a proper quantity of cyanide of potassium and place it over a grate fire to fuse. Into this fusing mass enter the steel article to be hardened, and, as soon as red hot, dip it quickly into cold water. The article will not only have obtained a very good temper, but it has also not become warped in the slightest degree. Another advantage of this method of hardening is that the polish of the article is not injured whatever—in case it has already been polished. The polish becomes slightly gray, which color, however, is easily removed by a few retouches with wood and a little fine steel rouge.

“As regards the warping of the article to be hardened, it must be stated that before hardening it must not be injured by hammer taps or careless glow heating, so that the interior texture of the steel is damaged. Well treated thus, turning arbors of from four to five centimeters long remained perfectly true, when hardened by this method. This is also excellent for hardening the detent springs of chronometers, by which the foot must always be much larger than the very delicate, flexible part of the spring. All the parts are equally heated in the cyanide bath, in consequence of which they experience no warping.”

[Moritz Grossmann proposed the lead bath for similar purposes.—ED.]

—IMPORTERS AND CUTTERS OF—
DIAMONDS,
AND MANUFACTURERS OF
DIAMOND JEWELRY.

58 Nassau Street,
29 Maiden Lane,
NEW YORK.

1 Tulp Straat,
AMSTERDAM.

1 St. Andrews St.,
Holborn Circus,
LONDON, E. C.



TRADE GOSSIP.

The following named jewelers were seen in town during the past month :

H. Welf, Cleveland, O.; G. Gay, Hartford, Conn.; J. R. Peckham, Topeka, Kan.; D. W. Van Cott, Omaha, Neb.; G. S. Simons, San Francisco, Cal.; W. Becker, Buffalo, N. Y.; A. La France, Elmira, N. Y.; M. Levy, Malone, N. Y.; L. Greil, Selma, Ala.; S. A. Bigelow, Boston, Mass.; J. Houseman, Grand Rapids, Mich.; B. Kuhn, Vincennes, Ind.; G. A. Lewis, Columbus, Ga.; B. H. Stief, Nashville, Tenn.; J. C. Manning, Springfield, Mass.; H. A. Jones, J. E. Simpson, J. Watson, Philadelphia, Pa.; A. C. Chase, Syracuse, N. Y.; A. Coe, Chicago, Ill.; E. A. Gillet, Buffalo, N. Y.; J. R. Knight, Boston, Mass.; G. Wolff, Chicago, Ill.; B. F. Williams, Philadelphia, Pa.; J. J. McDonough, Albany, N. Y.; C. H. Tuttle, Cleveland, Ohio; L. Lake, Baltimore, Md.; C. D. Hosley, Springfield, Mass.; O. Heeren, Pittsburgh, Pa.; H. Extein, Buffalo, N. Y.; J. Hopkins, Baltimore, Md.; C. J. Anderson, Chicago, Ill.; H. Keck, Jr., Cincinnati, Ohio; C. Lingemann, Detroit, Mich.; J. H. Otis, Hartford, Conn.; W. Morris, Philadelphia, Pa.; A. A. Horn, Pittsburg, Pa.; E. S. Shenshon, Kansas City, Mo.; J. C. Doering, (Leek, Doering & Co.), Cleveland, Ohio; Z. Auerbach, Montreal, Canada; E. H. Burr, Philadelphia, Pa.; J. D. Hunt, Chicago, Ill.; J. Goetz, Cleveland, Ohio; L. Lewis, Cleveland, Ohio; G. W. Clark, Syracuse, N. Y.; L. S. Stowe, Springfield, Mass.; R. P. Thorn, Jr., Albany, N. Y.; C. F. Adams, Chicago, Ill.; J. O. Horne, Pittsburgh, Pa.; S. Selig, Columbus, Miss.; A. Oppenheimer, J. M. Stewart, Philadelphia, Pa.; C. H. Jackson, Pittsburgh, Pa.; J. F. Rand, Portland, Me.; W. Paul, Boston, Mass.; M. Mayer, Albany, Ga.; C. Goldman, Middletown, O.; J. Goldstein, Shamokin, Pa.; J. B. Bohe, Cincinnati, O.; M. Timpane, Troy, N. Y.; Mr. Warner, Bridgeport, Conn.; S. C. Rosenthal, Binghamton, N. Y.; R. McCallum, Montreal, Can.; J. W. Tufts, Boston, Mass.; A. W. Guild, Buffalo, N. Y.; D. P. Cook, Hartford, Conn.; A. Sachs, New Haven, Conn.; M. S. Liberman, Syracuse, N. Y.; J. C. Freeman, Atlanta, Ga.; I. Brilleman, Albany, N. Y.; H. H. Fudger, Toronto, Can.; S. L. Barbour, Hartford, Conn.; E. Atwood, Bridgeport, Conn.; H. Birks, Montreal, Can.; J. A. Williams, Boston, Mass.; W. Wattles, Pittsburgh, Pa.; F. Stevens, Albany, N. Y.; C. Lesser, Chicago, Ill.; A. J. Steinfeld, Cleveland, O.; D. Davis, Pittsburgh, Pa.; J. McKee, Pittsburgh, Pa.; D. Ross, Wilmington, Del.; G. W. Williams, Cleveland, Ohio; G. R. Harms, Cincinnati, Ohio; C. F. Adams, Buffalo, N. Y.; G. Seifert, Quebec, Can.; F. O. Flagg, Springfield, Mass.; M. Heiman, Syracuse, N. Y.; M. A. Deimel, Herkimer, N. Y.; H. P. Koch, New Orleans, La.; D. Goldberg, Butte City, Mon.; E. Zahm, Lancaster, Pa.; F. T. Goll, Milwaukee, Wis.; H. C. Stayner, Milwaukee, Wis.; C. F. Jackson, Minneapolis, Minn.; N. Friedman, Muskegon, Mich.; J. Conrad, Cleveland, O.; Mr. Spaulding, Chicago, Ill.; A. Baird, Pittsburgh, Pa.; L. Kahn, Duluth, Wis.; C. Wendell, Oswego, N. Y.; L. Gottschalk, Baltimore, Md.; J. S. Kauffman, Pittsburgh, Pa.; A. W. Cogswell, Akron, O.; A. T. Galt, Montreal, Que.; J. Kopelowich, Rochester, N. Y.; H. Munger, Herkimer, N. Y.; and Mr. Leyson, of Leyson & Turck, Butte City, Mon.

—On the 12th inst. the Non-Magnetic Watch Company of America was admitted to membership in the New York Jewelers' Board of Trade.

—It is said that ex-Alderman Gustason, of Elgin, Ill., has been appointed to the management of the jewel department of the Aurora Watch Company, at Aurora, Ill.

—W. H. Einhaus will, about May 1, move his business from 43 Nassau street into the store of John E. Hyde's Sons, 20 Maiden Lane. The latter firm will retain the back portion of the office as heretofore.

—Edwin Want, the well-known optician, will, about May 1, move his business from No. 28 John street into the store now occupied as the office of the dyeing establishment of Barrett, Nephews & Co., 12 John street.

—Gilbert M. Simmons, Frank Slosson and Charles H. Bain lately filed articles of incorporation at Madison, Wis., founding the Kenosha Watch Case Company with a capital stock of \$100,000. The works will be at Kenosha, Wis.

—Owing to the death of Mr. Potter, the old house of Fanning & Potter, Providence, R. I., has been dissolved, the deceased's interest in the firm being purchased by Mr. Fanning, who will continue the business as heretofore, under the style of J. H. Fanning & Co.

—Several business men of New Bedford, Mass., have adopted preliminary measures for the formation of a company to manufacture watches under patents which, it is claimed, ensure reliability with cheapness. Charles R. Price is acting as manager and is holding the subscription paper.

—The New York Jewelers' Association has appointed J. E. Spencer, Nicholas Geoffroy and Henry Randel to co-operate with the pawnbroker's committee of the Jewelers' Board of Trade. Wm. R. Alling was first appointed, but being unable to serve, Mr. Randel was appointed in his stead.

—Work on the new Champlin Building at the corner of Clifford and Chestnut streets, Providence, is rapidly progressing and is near completion. S. B. Champlin & Son, the owners of the building, will by May 1 occupy the first floor, and E. S. Dodge, N. B. Nickerson and W. L. Ballou & Co. the upper floors.

—During the earlier part of the month a general exodus to Lower California took place from Los Angeles, Cal., and the jewelers seem to have been among the foremost of the adventurers. When the news of gold finds reached the city, Emile Quarre and several others departed to the fields. During the past few weeks over 2,000 people have gone from Los Angeles, and about the same number from San Diego. Though first reports gave expectations of another rival to Sutter's Mills of '49, it has now transpired that the whole was a scheme of the International Company to induce people, with adventurous turn of mind, to migrate to and settle in the territory.

—After attempting to murder his wife by firing two shots at her, Donald Frazier, a jeweler of Bryn Mawr, Pa., shot and killed himself on the morning of March 7. He had been a slave to liquor, drinking even raw alcohol kept in a bottle and used for watch repairing purposes. Early on the morning of the suicide, his wife detected the odor of alcohol about him, and while Frazier was out concealed the bottle. Upon his return, demanding it and being refused, he pulled a revolver and fired two shots at her, which took no effect. The wife rushed from the house. Upon her return shortly afterward with some neighbors Frazier was found dead upon the floor, the pistol tightly clutched in his hand and a bullet hole in his temple. The dead man had been in business in the town for eight years, and had earned a reputation for extreme eccentricity. At one time he was committed to the insane asylum, but was shortly afterward released. Recently he had developed a mania in religion. He was about forty years of age at his death, and had lived most peacefully with his wife for over ten years.

—The celebration of Mardi Gras at New Orleans this year was of special interest to the jewelry trade. The subject chosen for illustration in the pageant was "The Treasures of the Earth." The following were the principal floats in the procession: Pearls—represented by three figures, reclining in shells; the car was festooned with strings of imitation pearls. Rubies—A grotto where a feast with wine and music was in progress. Silver—An immense fountain in full play, surrounded by five figures. Opal—Four fairies lingering on a highly ornamented pavilion. Crystal—Thousands of prisms showering from numerous cornucopias. Diamond—A brilliant pyramid, by which stood a beautiful figure resplendent with imitations of diamonds. Sapphire—A bower floored with blue crystals and hung with garlands of flowers, white swans occupying the space at either end. Ivory—A car decorated with elephant heads and tusks, occupied by an African chief fanned by slaves. Gold—A grotto lined with gilt, occupied by two fairies, and a garden with flowers, foliage and verdure, all in imitation of gold. Amethyst—Eight figures reclining upon a car containing a bed of these gems, of tints varying from rich purple to light violet. Emerald—A sea in which rested an island spangled with imitations of this gem and inhabited by fairies. Coral—A submarine representation of great beauty, representing a coral reef, with mermaids and huge shell fish. Onyx—Four large shells upon a bed of cactus and palm leaves, in each shell a nymph.

—John F. Dodge, of Millbury, Mass., has disposed of his business to a Mr. Wiesman.

—The Berthiaume Jewelry Co., has moved its business from Crookston, Minn., to West Superior, Wis.

—Joseph Haber has withdrawn from the prominent jobbing firm of S. B. Dinkelspiel & Co., San Francisco, Cal.

—On March 9th, Edwin A. Thrall, 3 Maiden Lane, sailed for Europe on the steamer *Aurania*. He expects to return toward the close of May.

—L. H. Luke, for twelve years with Kent Brothers, Toronto, Ontario, now represents Kallmeyer Bros., of Detroit, in southern Ohio and Indiana, and Western Pennsylvania.

—Joseph Durst has sold out his business at Foxton, Mass., to Leon R. Hapgood, and has moved to Hudson, in the same state, where he is temporarily out of the jewelry business.

—C. S. Hauser, last month, sold out at auction, his stock at 432 1/2 Butler street, Pittsburgh, and reopened with an entirely new stock of everything pertaining to a first-class jewelry store, at 631 Smithfield street.

—On March 10th, Christopher Pfeifle, one of the best known bench workers in the jewelry trade of Detroit, died at his home from pneumonia. At his decease he was 63 years of age, and had been with M. S. Smith & Co. for over 30 years.

—On May 1, Leiter Bros. the well known jewelers of Syracuse, N. Y., will, owing to the proposed erection of a new block on the site of their present business, move their salesrooms to the store in the Pike block, formerly occupied as a dry goods emporium.

—J. B. Wood, representative of Charles F. Wood, arrived from Europe March 10, by the *Gascogne*, having purchased in the European markets extensive lines of gems and precious stones, well deserving the careful attention of manufacturers and dealers.

—Jacot & Son, the musical box importers, will, on May 1st, move from their present quarters at 37 Maiden Lane, to a larger and more centrally located store at 298 Broadway. This step is rendered necessary by the enormously increased business of this well known house.

—The employees of the Whitcomb Lathe Attachment Department of the American Watch Tool Co., had a re-union and dinner on the night of March 9th, at Vieth's new hostelry on Tremont street, Boston. The affair was most informal in its nature, and jollity reigned supreme.

—Among the numerous changes soon to occur in the trade in Providence, are those of Ostby & Barton and S. Albro & Co. On June 1 the former firm will add another floor to its facilities, and the latter firm will move down one flight and take the factory vacated by W. L. Ballou & Co.

—Among the exhibits from Maine at the forthcoming Paris Exposition will be a display of Mount Mica tourmalines, cut and mounted in a case. The object of this display is to illustrate the wide range of color for which these tourmalines are famous. It is expected that the exhibit will equal, if not surpass, that from any other part of the world.

—Icelus Fay, 226 Front street, Worcester, Mass., who recently failed is endeavoring to effect a compromise with his creditors, on the basis of 55 cents on the dollar. His liabilities amount to about \$2,000, and his assets \$1,250. Mr Fay has been in business for a number of years, both in Worcester and at Blackstone, but with very little success.

—G. T. Tress, Columbus, Ohio, who has been engaged in the jewelry business as long perhaps, as any one in the city, on April 1st, disposed of his stock and fixtures, and leased his quarters to F. F. Bonnett of the same city. Though this disposition was effected with the intention of retiring from business, it is said, however, that Mr. Tress will re-enter the trade at no distant day.

—Dewey & Ellis, Battle Creek, Mich., have bought out the business of Henry A. Bromberg, repairer, of the same town. Mr. Bromberg has gone to Paris to meet relatives from Russia, and settle an estate in that country from which he is a political exile.

—The American Waltham Watch Company is manifesting enterprise in a new direction. A spacious building has been erected in proximity to its works at Waltham, for the accommodation of three generators in which gas is to be manufactured for a system of lighting, heating, and motive power, to be applied to the watch factory.

—Work is progressing on the new watch factory at Otay, Cal., which is expected to be completed within two months. A number of watchmakers and their families are reported already on their way there from Springfield, Ill., and others are to be sent for as soon as accommodations can be arranged for them. The enterprise, it is safe to say, will prove an important factor in the building up of this thriving Pacific town.

—Word reaches us from Toronto, Ontario, that the Jobbers' Association, in conjunction with the Canadian Manufacturers' Association, has sent a deputation to the Capital to petition certain changes in the tariff. The jewelers desire that platers' metal be placed on the free list, the present duty being 20 per cent. The present method of grading rates on precious stones causes complications; the Association also seeks to obtain a uniform duty on them to simplify arrangements. There is expectation that the mission will prove successful.

—During the past month the new seven-jewel movement manufacturers of the New York Standard Watch Company met with such good favor, that the factory's facilities were taxed to their utmost capacity in the attempt to keep pace with the volume of incoming orders, but they did not succeed. The output, however, was about doubled on the first of the current month. Watchmakers and dealers are showing their appreciation of the merits of the movement in the most natural and desirable way—the placing of liberal orders. The company will shortly occupy their new suite of offices in the Corbin Building, 13 John street.

—A change in the trade, during the past month, that caused considerable comment was made in the management of the New York office of the Dueber Watch Case Mfg. Co. John W. Sherwood, the manager of the company's Boston office was installed therein in the place of George W. Mindil and I. G. Hatch, whose services were dispensed with. The office is to have an increased force of able assistants and as large a stock of Dueber cases and Hampden movements as can be spared will be carried. Mr. Sherwood retains the supervision of the Boston office, though his residence and headquarters will be in New York. As he is very popular in the trade, his many friends will be pleased to hear of this deserved promotion.

—Among the one hundred thousand persons from New York who are said to have visited Washington to witness the recent inaugural ceremonies, were William R. Alling of Alling & Co., and Ludwig Nissen, of Nissen & Co. Mr. Alling had the honor of an interview with President Harrison. Being an old family friend to the McKee's, he was very cordially received by them, and was present in the Senate chamber during the President's installation, a privilege accorded to comparatively few. Mr. Nissen cites a serio-comic incident which might have had a more serious than comical termination, in connection with his trip. It occurred on his way from Washington to Wheeling, there to visit some friends. The car in which he traveled contained a number of anti-Harrison men, who were lauding ex-President Cleveland to the heavens for the good sense he displayed in protecting the new President from the rain while the latter addressed the assemblage on the 4th. Mr. Nissen being a strong Harrison partisan, explained with a tinge of sarcasm in his voice, that that was the only time that Mr. Cleveland had occupied his correct position. Threatening glances were directed upon him, and he thought it advisable to seek the seclusion that another car afforded.

—Bartens & Rice will on moving day transfer their business to the store at No. 20 John street, now occupied by D. W. Granbery & Co.

—At the forthcoming Paris Exposition, Kent & Stanley, of Providence, will display a case of their seamless gold filled chains. H. H. Brainerd, the firm's representative, will go to Paris to supervise the exhibit, and to make arrangements for placing their goods on the French market.

—Patent letters were last month granted on Dr. Mack's opera glass holder, which is manufactured by the Julius King Optical Co. A visit to a theatre will convey to an observant mind an idea of the popularity this handy device is gaining.

—Since making New York the distributing center for Trenton watches, the demand for export trade has shown a marked increase. Several large invoices of these watches were shipped by last week's steamer's to Mexico, Australia and the United States of Colombia.

—Our readers are asked to notice the advertisement of the well-known importer of optical goods, J. B. Laurecot, of 33 Maiden Lane. Mr. Laurecot extends to the trade who are visiting Europe, an invitation to make use of his headquarters in Paris for correspondence, etc., where everything will be done for their interest.

—On the 23d of April the safes of Koch & Dreyfus will be shipped from New Orleans to this city, and are expected to arrive here in time to be installed in the firm's new quarters at 22 John street (the floor to be vacated by the Elgin National Watch Co.) before its occupancy by the firm May 1. Leon Dreyfus, the junior member, arrives in the city about the 26th.

—John B. Yates, who has been located for the past year at 200 Broadway, has found it necessary, on account of increasing business, to take two large offices at 191 Broadway, fronting on Broadway and Dey streets, of which he will take possession about April 20. He has purchased a full line of jewelry, and added this and a line of opera glasses to his watch business.

—Jacob Stern, of Stern & Stern, has just returned from a western trip, and though the prevailing report of trade is at present not encouraging, he says that the results of his trip are satisfactory both to himself and to the firm. The firm's three other representatives, Joe Phillips, Frank Shadbolt and M. Ettinger are fulfilling more than was expected when they started out.

—A large and attractive wall case has been added to R. & L. Friedlander's business facilities, in which are displayed lines of every make of lathe and a line of diamond scales—a new departure of the firm's. The friends of F. Bloecher, the bookkeeper of the firm, who for two weeks was confined to his home from illness, will be pleased to hear that he is about again, well and hearty.

—To "fill a long-felt want," the New York office of the Julius King Optical Co., under the able supervision of Leo Wormser, has established a complete repair shop in the basement of its present quarters at 4 Maiden Lane. All orders in grinding, centering and job work can now be done on the premises. Four men are constantly engaged, and with employment of electric instead of foot power, generated by a Daft electric motor, it is to be expected that all work will be executed with accuracy and promptness.

—The observant visitor to Charles Jacques' store, at 2 Maiden Lane, will notice several new lines of goods that have just been added to his regular stock. Chiming clocks of London importation, royal Worcester clocks of most elegant designs, in both pink and old ivory effects, top pieces of various designs of onyx and bronze-gilt combination, side pieces of the same materials—these, together with the regular lines of marble, bronze, onyx, Sevres, faience and other clocks, and bisques, bronzes, etc., make an ensemble of beauty and interest, and one that buyers cannot but give more than a passing consideration.

—Of late years it has been the custom of the employees of the Towle Manufacturing Co. to have an annual entertainment, the expenses of which have been defrayed by the company. This year, however, the company made a proposition to the employees that they could have their choice of \$500 for an entertainment or \$1,000 placed on deposit to form the nucleus for a benefit fund for those employees who were sick and were unable to work. The employees voted upon the matter, and the result was in favor of the benefit fund. Each member on the sick list, after the first week's illness, is to receive \$5 weekly until able to resume work. Weekly dues of ten cents are required from members to perpetuate the fund. At present \$800 are put into the stock of the company at six per cent. interest, and the remainder deposited in the bank. This movement is most commendable, and is in line with the liberal though earnest business principles of the Towle Company.

—S. H. Bauman & Co., of 710 Washington street, and E. Massa & Co., of 210 North Fourth street, St. Louis, Mo., have consolidated, and as soon as inventories are completed will incorporate under the laws of the State. Both firms have been doing a thriving business, and the consolidation has caused considerable surprise. The new company will be located on the second floor of 309 North Broadway, and will, no doubt, be among the largest material houses in the West.

—Much interest is excited among the trade in the existing trouble between Gustave Rehmann and Thomas C. Jones, of Newark, who comprise the firm of Retmann & Jones. Immediately after the formation of the co-partnership, last September, trouble began to arise which has culminated in a suit for a dissolution brought recently in the Supreme Court of New York by Mr. Rehmann. This gentleman, in affidavit, charges Mr. Jones with the seizure of property of the concern valued at \$11,000; in consequence whereof, business has been entirely suspended since the date of the seizure, February 9. A general denial is put in by the defendant, who asserts that he has taken nothing but his share of the profits. On motion of the plaintiff, Judge Lawrence, on March 13, appointed Bernard J. Caserly receiver for the firm with a bond of \$10,000.

—On March 30th George H. Houghton, manager of the Gorham Manufacturing Company, sailed for Europe to represent the company at the Paris Exposition. They have secured a space 32 feet square in the center of the American building, and will fill a number of wall and counter cases, now being made in Paris expressly for them, with the best and most salable patterns of their goods, the intention being rather to show the excellency of their commercial wares than to exhibit any special ornamental pieces made for the occasion only. They have opened an office at 36 Avenue de l'Opera, where Mr. Houghton will be glad to welcome any of his friends who may visit the Exposition. He will be absent several months, and will no doubt return bringing honors for the company.

—Prospective purchasers of Easter gifts and memorials, will be exceedingly interested in the display of goods in the ecclesiastical department of the Gorham Manufacturing Co. Persons of every denomination, from the Mormon to the Mohammedan, can be accommodated. The list of articles usually kept in stock numbers about seventy-five, and includes everything in church decoration and religious observance. Tablets for churches, public buildings, schools, colleges, etc., in brass and ivory, silver and gold communion sets, altar crosses, candelabra, eagle lanterns, pulpits, sanctuary lamps, alms, basins and innumerable other articles in brass are displayed on all sides. As agents of the well-known firm of artists, Heaton, Butler & Bayne, of London, they carry a large collection of stained glass and church decorations in stock. Photographs and catalogues will be sent to parties upon application.

—The complete list of jewelry firms to date who have leased offices in the Corbin Building, and the floors on which their quarters will be located, is as follows: On the second floor, J. B. Bowden & Co., Unger Bros., Keller & Untermeyer and H. C. Haskell; Charles Glatz will probably occupy a suite on this floor. On the fifth floor, the Elgin National Watch Co. and the Brooklyn Watch Case Co.; they will occupy almost the entire floor. On the sixth floor, Illinois Watch Co., Fidelity Watch Case Co., C. K. Colby, Hamilton & Hamilton, Jr., Wm. H. Ball & Co. and Wm. C. Greene & Co. On the eighth floor, the Celluloid Mfg. Co. J. H. Noyes, Secretary of the National Association of Jobbers in American Watches will occupy the front tower room, "far from the madding crowd." The store on John street, which was intended for the Middletown Plate Co., but which proved too small for its business, has been leased by the New York Standard Watch Co.

—William C. Edge, of Wm. C. Edge & Sons, Newark, N. J., is deeply interested in extending the application of his famous machine for the manufacture of knit or woven gold work to the production of sash cords, pulley belts and other articles of hardware in which their process can be applied advantageously. A company called the Metallic Belt Company, with a capital of \$100,000, is about to be formed to control Mr. Edge's patent, and enter extensively into the manufacture of specialties in this line. The process has been used by Mr. Edge for several years in the manufacture of gold jewelry, but the full value of the invention has not been realized until now. It is probable that a large fortune awaits Mr. Edge in his new venture. Notwithstanding these preparations of the head of the house for branching off in an entirely new direction, Wm. C. Edge & Sons are getting out a great variety of new styles in both bracelets and chains of their celebrated woven work, and some beautiful specimens of watch cases decorated with inlaid gold of different colors, in arabesque or floral designs.

—On March 20, T. F. and M. J. Bogle sold out their interest in the firm of T. F. & M. J. Bogle, White River Junction, Vt., to C. C. Bogle, the senior partner and manager, and B. L. Bogle, who will continue the business under the style of Bogle Brothers.

—Cross & Beguelin, 21 Maiden Lane, have obtained the agency of the La Salle, Illinois, nickel alarm clocks; it would be advisable for eastern dealers, if they wish to save time, to send their orders direct to them. The firm has also added to their stock a full line of T. A. Willson & Co.'s optical goods.

—Henry E. Oppenheimer & Co., of 47 Maiden Lane, have patented an improvement in lace pins which insures safety against loss in a far greater degree than in the old style. It also protects the lace or material from tearing, and is at once strong and neat, and can be sold to manufacturers finished, ready to be soldered to any lace pin.

—Traitel Bros., 49 Maiden Lane, intending to retire from business, are offering for sale the stock, office fixtures and good will of the establishment. The factory is in active operation at the present writing and can be examined at any time. The firm has, during its career of fifteen years, attained an enviable reputation for manufacturing attractive and salable lines of all styles of rings and pins.

—Downing, Keller & Co., who have been occupying temporarily bench room in Julius Wodiska's factory, No. 49 Maiden Lane, owing to the recent burn-out of their own factory at No. 52, have moved into the old quarters and are now ready to meet the demand of business with increased facilities. Their lines of pearl, diamond and black onyx goods and fancy rings will be enlarged, and numerous new designs introduced.

—J. Eugene Robert & Co. report a steady demand for their chronographs with split seconds and minute repeaters. Their several other lines of foreign movements, the Agassiz and Longines, fitting 6, 8, 16 and 18 size cases, in three grades, and the Louis Audemars and Jules Nonard timekeepers, for which they are the sole agents, are meeting with a greater demand than the prevailing dullness of trade should warrant.

—At Charlestown, Mass., on March 9, occurred the death of Samuel G. Thompson, one of the pioneers of the jewelry trade in that city. He carried on his business on Washington, Hanover and Winter streets at different periods, but for some years past had not been active owing to advanced age and its attendant infirmities. At his death he was almost 71 years of age. His funeral took place on the 12th from his late residence.

—At the annual meeting of the National Association of Jobbers in American Watches, on Tuesday, March 5, the following gentlemen were elected as the Executive Committee: President, S. Oppenheimer, of Oppenheimer Bros. & Veith; F. R. Simmons, of Henry Ginnel & Co.; L. Stern, of Stern Bros. & Co.; S. F. Myers, of S. F. Myers & Co.; L. Herzog, of L. Herzog & Co.; H. H. Butts, of H. W. Wheeler & Co.; and Ira Goddard.

—The demand for the new 18 size non-magnetic movements lately put on the market by the Non-Magnetic Watch Co. far exceeds their capacity to supply, and every effort is being made to increase the manufacturing facilities. The company will have a large and attractive display of their watches, containing Paillard's non-magnetic balance and hair springs, at the Paris Exposition, and will also compete with the manufacturers of the world in marine chronometers.

—Simultaneously with the blooming of the flowers of spring, do many novelties in natural-colored floral designed jewelry, manufactured by Groeschel & Rosman, of 27 John street, make their appearance in the market. In addition to an extensive line of these goods, very beautiful to behold, the firm can show buyers some handsome chain bracelets in Roman gold, ladies' Queen chains and ladies' garters with gold buckles. The firm makes as a specialty a line of enameled flower jewelry in sterling silver, plated with gold, producing the effect almost of 24 karat gold.

—Attention is directed to the display advertisement in this issue of the Trenton Watch Co., who have recently taken offices at 177 Broadway, and greatly increased their production to meet the growing demand for their popular movement. Testimonials of the most flattering kind are constantly being received by them from dealers who find the "Trenton" the most profitable low-priced watch they can handle, and improvements in mechanical construction and finish have been made that will ensure still better satisfaction in the future. All communications should be addressed to the New York office at 177 Broadway. Their new net price list will be sent to the trade on application. J. Quincy Walker, who has charge of the New York office, is widely known to the trade as a hustler who will not let the grass grow under his feet even in the spring.

—Theodore Lexow, for many years with Henry Fera, is now sole American agent of the widely known European diamond house of Lewisohn & Co., and has opened an office in the Knapp Building.

—About two months ago George Kremetz, of Kremetz & Co., received a fall on the sidewalk, the effects of which, at the time, were considered of no consequence, but which now prove to have been of a somewhat serious nature. He is now confined to his home, unable to attend to the demands of business, and it is feared that his spine is affected, though up to the present writing no positive developments have been detected. The business of the firm is, however, on the upward movement. A wing 30x70 feet in ground dimensions and three stories high is being erected on to the present structure, and two floors of it will be occupied by Kremetz & Co.

—J. T. Scott & Co. call attention on another page to their new cuff buttons, called the "Anti-Swear," of which they are the sole manufacturers. The action of this button, which is automatic, is entirely new and different from any other in the market. J. T. Scott & Co. have now a large and complete line of these buttons in 1011 plate and gold front, and expect soon to have ready a good assortment in gold. They propose to sell them only to the regular jewelry trade, and thereby prevent ruinous competition from dry goods notion or other outside trade. This plan will, no doubt, receive the encouragement of the trade.

—The factory of the Newark Watch Case Co., on Arlington street, Newark, N. J., is nearing completion, and the company will begin turning out cases at once. The building they occupy has four floors, well-lighted and thoroughly fitted up with the latest improvements in machinery, everything being done to economize space and time and facilitate a large production. Victor Nivois, the well-known engraver, who will assume the active management of the new concern, states that they will have a capacity of 1,000 cases a week, including both filled and gold, and that ample capital to meet all requirements is behind them. Henry Lefort will continue to occupy one floor of the building for his watch crown factory as heretofore, and his crowns will be used by the Newark Watch Case Co. The new company will soon open an office in Maiden Lane.

—The Newport Aluminum and Steel Co. was recently organized at Newport, Ky., to produce aluminum on a large and consequently cheap scale. Much has been said and written upon this metal, and it has been termed "the coming metal." Its inherent qualities have never been disputed, and its range of usefulness is practically unbounded. It is very light, superior to silver and equal to gold in brilliancy; it is extremely durable, malleable and elastic, and it will not tarnish like silver. These qualities render it almost invaluable for the manufacture of ornaments, jewelry, household utensils, cutlery and hollow ware. For years methods have been sought whereby to produce the metal upon a scale extensive enough to allow of its being sold at a comparatively low figure. This point has almost been attained by the above mentioned company as may be seen by its quotations in another portion of this issue.

—The Metropolitan Burglar Alarm Co. will in a few days move into its new quarters at 6 Maiden Lane, formerly occupied by E. E. & A. W. Kipling. The new floor is most centrally located with reference to the jewelry trade, thus rendering it very convenient in case of demand. The establishment will have an electrical work room and lodging quarters for a complete reserve force. At present, about fifty-five galvanometers and batteries, representing that number of connections, have been installed, but the capacity of the floor is two hundred and fifty connections. Since the proposed removal from 125 Fulton street to Maiden Lane, orders have been far ahead. The points that should deeply interest the jewelers are, namely, that a specialty is made of protecting jewelry safes, that the headquarters are in close proximity to their business offices, and that the connections are perfectly reliable. The company is incorporated with a capital of \$50,000, amply sufficient to carry on the business, and the subscription books are open to any contracting for the connection. The following firms are connected:

H. W. Wheeler & Co., Alling & Co., C. Cottier & Son, Lewis, Kaiser & Luthy, factory and office, Day & Clark, Kuhn & Doerflinger, Blancard & Co., I. Goldsmith & Co., L. Nissen & Co., Levy, Dreyfus & Co., Henrich & Graves, J. Brunner's Sons, Fulton street, H. Wilkins, Wm. Barthmann, Engelfried, Braun & Wiedman, J. Brunner's Sons, Broadway, H. Elcox & Co., Kaldenberg Co., Silas C. Stuart, Shafer & Douglas, E. Aug. Neresheimer & Co., S. Lindenborn, Downing, Keller & Co., H. C. Hardy & Co., Hodenpyl & Sons, M. Meyers, John Haug, A. J. Hedges & Co., Sexton Bros. & Washburn, Julien Gallet & Co., Joseph Fahys & Co., George W. Shiebler, V. Jansky, Brooklyn Watch Case Co., Charles Magnus, M. Fox & Co., Sussfeld, Lorsch & Co., G. & S. Owen & Co., Henry Moss, C. Sidney Smith, R. A. Breidenbach, Sanford & Cook, J. F. Crandall and Saunders & Ives. Connections are being completed for the following firms: M. B. Bryant & Co., William Downey, Mulford & Bonnet, Wm. H. Ball & Co., Bruhl Bros. & Co., Chas. F. Wood, Keller & Untermyer, and Lewis, Wessel & Leward.

PAILLARD NON-MAGNETIC WATCHES.



New York, Feb. 15th, 1889.

AN article of merit always commends itself, and a living proof of this fact is found in the steady increase in the demand for Paillard Non-Magnetic Watches. Recognizing the requirements for a larger watch, and in order to better enable dealers to supply the demands of their trade, we have placed on the market three grades of 18 SIZE, FULL PLATE, S. W. MOVEMENTS, IN H'T'G AND O. F.

No. 43, NICKEL.



15 Ruby Jewels in Gold Settings; Adjusted; Patent Regulator; Double Sunk Dial; Breguet Hair Spring.

No. 45, NICKEL.



15 Jewels, in Settings; Adjusted; Patent Regulator; Double Sunk Dial; Breguet Hair Spring.

No. 47, GILT.



15 Jewels, in Settings; Adjusted; Patent Regulator; Double Sunk Dial; Breguet Hair Spring.

These movements are of American Manufacture, and contain Paillard's Patent Non-Magnetic Compensation-Balance and Hair-Spring, and full Non-Magnetic Escapements, and will be followed by other grades as soon as practicable. We invite the careful attention of the trade to these goods, as well as to our full line of 16 size movements, a full stock of which will be found with our Special Wholesale Agents.

Very Respectfully,

NON-MAGNETIC WATCH CO.
OF AMERICA.

A. C. SMITH, General Selling Agent,

177 & 179 Broadway N. Y.

—I. Emrich & Co. will move May 1 from their present quarters at 66 Nassau street to 52 Maiden Lane.

W. & S. Blackinton's New York office will, after May 1, be in the present office of H. Muhr's Sons, 16 Maiden Lane, who leave Maiden Lane for John street, occupying the spacious floor to be vacated by Bartens & Rice at No. 20.

—Messrs. Day & Clark, goldsmiths and manufacturers of fine, rich, diamond jewelry, have now before the trade new designs in goods of their own manufacture, and it need hardly be repeated that the productions of this firm are always well worthy the attention of the trade.

—The long-established Fulton street firm of H. N. Squire & Sons will, May 1, occupy the store at 18 John street, the present quarters of John Foley. Mr. Foley has in mind several desirable locations to which to transfer his business, but up to the present writing has not made a decision.

—The assigned stock of Oliver Brothers was sold at sheriff's auction on the 11th, to satisfy a number of judgments. Many prominent dealers were present at the auctioneer Topping's rooms, 80 White street, and the amount realized was very satisfactory. E. J. Oliver is now doing business at 21 John street.

—Bowman & Musser, Lancaster, Pa., are issuing a net price list, in the form of a little book, of American movements, gold, filled and silver cases, Waltham chronographs and complete watches, carefully revised to March 11. The book is accompanied by a little folder giving some interesting points in connection with their business.

—Owing to the demands of increasing business, Henry Kohn, of Hartford, Conn., on the first of the current month moved to a spacious store at 347 Main street, a most desirable location, where, no doubt, his business will still increase. Mr. Kohn intends henceforth to direct his attention exclusively to diamonds and watches.

—The firm of Pedersen & Buckingham, 1½ Maiden Lane, which has been in existence for about a year, has been dissolved by mutual consent. Jeus F. Pedersen will continue the business, and the retiring member, E. W. Buckingham, will locate in Buffalo, N. Y., as agent for the New York Watch Co., of that city, which lately succeeded Hiram Hotchkiss.

—The guests of the Hotel Peterson, Paris, Tex., including F. S. Ogilvie, representing A. Alling Reeves, and C. E. Jenkins of the Leroy W. Fairchild Co., at 2 o'clock on the morning of March 25, had a close call, from the cry of "fire!" which resounded through the building. It was, however, the building adjoining the hotel that was afire. All the hotel guests saved their effects.

—The jewelry establishment of the late Dwight H. Buell, of Hartford, Conn., one of the victims of the recent terrible hotel disaster in that city, has been purchased by C. R. Hansell and F. H. Sloane, who will continue the business under the firm name of Hansell, Sloane & Co. Mr. Hansell had been in the employ of the deceased for a dozen of years, and Mr. Sloane for nearly the same length of time.

—Perhaps the most artistic line of fine pure silver novelties manufactured by the electro-deposit process in the trade may be seen at the works of the Alvin Manufacturing Co., 24 Boudinot street, Newark. Cane and umbrella handles, toilet and manicure sets, hand mirrors, crystal glass pitchers, hair brushes, combs, whisk brooms, and shaving brushes, elegantly mounted in sterling silver, are included in a list of productions too numerous to specify. Fine etched work is also produced as a specialty.

—Though unknown to many of the present generation of jewelry manufacturers, many of the older members will recollect William Harrison, who ten years ago was a prosperous manufacturer in Newark. Business reverses overtaking him his brain became affected, and for nine years he worried out his existence in the South Orange Avenue insane asylum, Newark. He died there on March 3. The announcement of his death cleared up a partial mystery; few of his old acquaintances were cognizant of his whereabouts.

—The Committee on Art and Exhibition of the Centennial Celebration of the inauguration of George Washington as President, will make a special feature in the Loan Exhibition of Historical Portraits and Relics, of the display of gold and silver plate of the Inauguration Period. John H. Buck, superintendent of the ecclesiastical department of the Gorham Manufacturing Company, and the author of "Old Plate, Ecclesiastical, Decorative and Domestic; its Makers and Marks," will superintend the arrangement and proper cataloguing of this part of the exhibition. It is thought that the exhibition of the best pieces of the plate, both that of home production and that imported from Europe, will prove of great artistic and historical interest.

—L. A. Cuppia have fitted up at No. 42 East 14th street one of the most convenient factories for the manufacture of silver novelties in New York city. The office and shop are on one floor; the former, overlooking Union Square, is light, cheerful, and furnished in elegant style. The factory contains all the newest and most improved machinery, and is arranged with every regard for health and comfort. The firm are having a great run on electro-deposit work, such as cane handles, paper-cutters, etc., and on silver hair-pins and garter and belt buckles in both bright and oxidized finish. They have enormously increased their production since removal, but find it almost impossible to keep any stock on hand.

—The following letter was received by Edward Forman, receiver for the late firm of N. Matson & Co. of Chicago:

New York, March, 1889.

Mr. Edward Forman, Dear Sir:—The undersigned who were among the creditors of the late firm of N. Matson & Co., desire to express to you their appreciation of the ability and faithfulness which you exhibited while managing the affairs of that firm as receiver, and they feel that a large share of credit is due to you for your fidelity to the trust imposed, and that a much larger result was obtained from the estate than would have been possible under other circumstances, and they ask your acceptance of the enclosed check as an expression of this appreciation, and of their esteem and regard for you.

They also desire to express the hope that you may live many years to enjoy prosperity in the new business connection you have recently formed. Gorham Mfg. Co., E. Richardson & Co., G. & S. Owen & Co., Robbins & Appleton, A. J. Hedges & Co., Downing, Keller & Co., Pearce, Kursh & Co., Jeannot & Shiebler, Thos. G. Brown & Sons, Lewis, Wessel & Leward, Carter, Sloan & Co., Sexton Bros. & Washburn, C. Sidney Smith, Day & Clark, John E. Hyde's Son's, J. F. Fradley & Co., S. Cottle Co., Durand & Co.

—False and misleading statements having appeared in the daily and trade papers in reference to the transactions of Sanford & Cook, diamond brokers, of 14 John street, with one Post of Chicago, it seems desirable that the facts should be correctly stated. Post was introduced to Mr. Sanford by a friend of the latter's, and bought about \$1,000 worth of goods, paying cash for them. After returning to Chicago Post sent for goods several times on memorandum, representing that he had means of disposing of them, but must have a little time to realize. In January Mr. Sanford went out to settle up matters, his suspicions having been aroused by what he had heard. He took short notes in settlement. On the 15th of March it was reported that Post, who was called the Ferdinand Ward of Chicago, had disappeared, and Mr. Sanford boarded a westward train at once. He succeeded in attaching property valued at \$30,000, to satisfy his claim of \$1,800, and feels satisfied from his latest advices that he will not lose a cent by his transactions with the absent Mr. Post of Chicago.

—The Waltham Watch Tool Co. of Waltham, Mass., recently acquired the exclusive right of manufacture and sale of the Hopkins patent foot wheel from George E. Hobbs, of Waltham, who purchased the patent shortly after it was granted, fifteen years ago, and who manufactured the article and urged its wide popularity until he disposed of it to the above mentioned company. The new manufacturers are busy bringing out a large number of the wheels. Any words of praise at this late day in reference to the article would prove but reiterations of former opinions. The list of lathes, attachments and other tools produced by the Waltham company is very lengthy, and includes almost everything necessary for the manufacture and repairing of watches. Besides the Hopkins lathe, foot wheel, patent chuck, "A," uprighting, filling and jewelers tool, patent slide rest, patent universal head, and patent case tool, we notice the Waltham Lathe patent "Gem" pivoting chuck, wheel cutting attachment Waltham screw driver, and—well, they are too numerous to specify.

—During the last fall season the demand for goods made upon the factory of John A. Riley, on Union Square, was far beyond its capacity. Night work was instituted, and additional mechanics engaged; yet, with a force of about 45 men, it was unable to turn out enough goods to fill orders. The usually dull months of January and February still saw the same rush of manufacture as did December. The lease of a portion of the same floor to Hebbard & Brother from Mr. Riley having recently expired, the latter has, in order to prevent the incapacity experienced last year, added it to his former facilities, which are now practically doubled, both office and factory. New machinery and work benches are being installed, and the factory, when in full blast, will provide work from between 75 and 100 hands. The floor space is approximately 5,000 square feet. As heretofore, the same line of fine rich goods will be manufactured—ladies' gold brooches and bracelets; gold and silver bead necklaces, in one, two, three, four and seven strands; ladies' miniature brooches, side and back combs and hairpins—the line and sale of the latter being especially large.

TABLE OF CONTENTS.

A Few Points in the Adjustment of Anchor Watches.....	72	Electricity and Magnetism.....	65	Obituary—Smith Owen, David B. Churchill, Wheelock P. Bingham.....	30	The Attleboros.....	44
A New-Fangled Wedding Ring.....	52	Fashions in Jewelry.....	55	On the Use of Anti-Magnetic Compensation Balances and Hair Springs.....	48	The Jewelers' Security Alliance.....	31
Around Boston.....	41	Foreign Matters.....	29	On the Values of the Rarer Minerals.....	62	The Parts of the Lever Escapement and their Functions.....	71
Chicago Briefs.....	83	Gold in Cabinets.....	48	Paris Gossip.....	51	The "Poesy" Engagement Ring.....	84
Communications.....	34	Gossip of the Month.....	21	Providence Notes.....	52	The Ring Suspension of Chronometers.....	66
Competition for the Rating of Watches at the Geneva Observatory.....	40	Jewelers' and Tradesmen's Company, The.....	96	Recent Patents.....	31	The Quaker City.....	33
Complete History of Watch and Clock Making in America—Watch Case Making.....	25	Jewelers' League, The.....	62	Repairing and Polishing Marble Clock Cases.....	78	To the Associates of the Co-operative Guild.....	34
Conical Pivots.....	72	Labor Saving Aids.....	47	Resistance—"Intensity" of Current.....	70	Trade Gossip.....	87-96
Corbin Building.....	43	Magical Clock.....	73	Sad History of Methuselah & Co.....	38	What Waltham is doing for the Watch-makers of the World.....	26
Detached Lever Escapement, Problems in.....	69	Marfels Watch Collection (Illustrated).....	73			Workshop Notes.....	80
		Mechanical Ocular Defects.....	61				
		New Nippers.....	70				

INDEX TO ADVERTISERS.

Abbott, Henry.....	91	Dinkelspiel, S. B. & Co.....	107	Mathey Bros., Mathez & Co.....	14	Scott, J. T. & Co.....	8
Abry, Chas. Leo.....	68	Didlsheim, Hipp.....	27	McCall & Newman.....	64	Sexton Bros. & Washburn.....	35
Alkin, Lambert & Co.....	68	Downing, Keller & Co.....	32	Merritt, S. F.....	17	Sheafer, W. H., & Co.....	27
Albro, S. & Co.....	Inside back cover	Dueber Watch Case Mfg. Co.....	10	Middletown Plate Co.....	11	Simpson, Hall, Miller & Co.....	59
Alvin Mfg. Co.....	35	Edge, W. C. & Sons.....	27	Miller Bros. & Co.....	54	Smith & Knapp.....	91
American Watch Tool Co.....	64	Evans, W. F. & Sons.....	60	Montgomery & Co.....	107	Smith, Alfred H., & Co.....	23
American Waltham Watch Co.....	50	Fidelity Watch Case Co.....	46	Moore & Horton.....	64	Smith B. & W. B.....	outside back cover
Ansonia Clock Co.....	2	Fisher & Sons.....	49	Muhrs' Sons, H.....	39	Special Notices.....	101
Anti-Magnetic Shield & Watch Case Co.....	15	Floyd, Pratt & Rounds.....	59	Myers, S. F. & Co.....	54	Spencer Optical M'fg Co.....	9
Atlantic Watch Case Co.....	103	Fox, M. & Co.....	32	Newark Watch Case Co.....	6	Sterling (The) Company.....	4
Atkinson Bros.....	56, 75	French, J. H.....	60	N. Y. Watch Case Spring Co.....	101	Stern & Stern.....	18
Bartholomew & Peckham.....	107	Friedlander, R. & L.....	12	New Haven Clock Co.....	35	Stockwell, E. R.....	28
Beguelin, Tell A.....	100	Gorham Mfg. Co.....	20	Newman, Louis, Jr.....	107	Sussfeld, Lorsch & Co.....	28
Bedchimer, I.....	107	Groschel & Rosman.....	32	Newport Aluminum & Steel Co.....	54	Tannenbaum, L & Co.....	29
Bennett, Jacob's Sons.....	12	Haskell, H. C.....	49	New York Standard Watch Co.....	49	Taylor & Bro.....	27
Birch, John S., & Co.....	100	Hausburg, O. E.....	107	Nicholson File Co.....	54	Ternend, F.....	107
Blackinton, W. & S.....	79	Hedges, Wm. S. & Co.....	82	Nissen, Ludwig, & Co.....	97	Thomas, Seth, Clock Co.....	Inside front cvr & 3
Blancard & Co.....	67	Hoffer, A.....	45	Non-Magnetic Watch Co.....	95	Thrall, Edwin A.....	67
Bookhout Bros.....	107	Howard, S. P.....	Outside back cover	Nye, Wm. F.....	93	Towle M'fg Co.....	56
Bowden, J. B., & Co.....	68	Hyde's Sons, John E.....	79	Odenhelmer & Zimmern.....	108	Trenton Watch Co.....	92
Briggs, J. & Sons.....	17	Illinois Watch Co.....	81	Oliver, W. W.....	98	Troemner, Henry.....	107
Brooklyn Watch Case Co.....	13	Imhauser, E.....	107	Oppenheimer Bros. & Velth.....	59	Valentine & Co.....	67
Bryant, M. B. & Co.....	45	Jacot & Son.....	17	Oppenheimer, Henry E. & Co.....	81	Van Moppes, D. L.....	107
Buhler & Nanz.....	75	Jacques, Charles.....	28	Owen, G. & S., & Co.....	28	Waltham Watch Tool Co.....	14
Bynner, T. B.....	107	Jeanne, Leon P.....	68	Palrpoint M'fg Co.....	2	Valuable Instruction Books.....	Inside b'k Cover
Carter, Sloan & Co.....	53	Jeannot & Shiebler.....	63	Perclval, D. C., & Co.....	76	Wallace, R., Sons M'fg Co.....	68
Cattelle & Decker.....	75	Keller, Chas. & Co.....	91	Peterson & Royce.....	75	Want, Edwin.....	12
Chalmers-Spence Co.....	60	Keller, L. H. & Co.....	100	Pforzheimer, Keller & Co.....	49	Washburn & Moen Mfg. Co.....	107
Chatham National Bank.....	42	Keller & Untermeyer.....	91	Plainville Stock Co.....	76	Watchmaker, Jeweler and Silversmith.....	100
Cheever, J. G. & Co.....	32	Kendrick & Davis.....	76	Platt, Chas. S.....	Outside back cover	Waterbury Clock Co.....	1
Chicago Horological Institute.....	45	Kent & Stanley.....	60	Prindle & Russell.....	67	Waterbury Watch Co.....	85
Clark, A. N.....	60	Ketcham & McDougall.....	99	Randel, Baremore & Billings.....	86	Welch, E. N., M'fg Co.....	1
Colby, C. K.....	35	Koch & Dreyfus.....	19	Riley, John A.....	46	Wheeler, Hayden W. & Co.....	97
Columbus Watch Co.....	88	Kohlhusch, Charles.....	107	Robert, J. Eugene, & Co.....	63	Wiesbauer Mfg. Co.....	79
Combremont, L.....	18	Krementsz & Co.....	97	Rogers & Bro.....	7	Wiggers & Froelich.....	Inside back cover
Conover, D. F. & Co.....	12, 18	Lady Racine Chatelaine Watch.....	32	Rogers, Smith & Co.....	16	Wilkinson, C. B.....	107
Cooke, B. J's. Sons.....	79	Laurencot, J. B.....	17	Russian Reproductions.....	99	Woglom, Gilbert T.....	64
Cross & Beguelin.....	15	Lawson & Van Winkle.....	18	Russell, Chas. A. & Co.....	Inside back cover	Wood & Hughes.....	27
Crossman, Chas S., & Co.....	63	Lelong, L. & Bro.....	outside back cover	Russell, Irving L.....	49	Wood, Chas. F.....	67
Crouch & Fitzgerald.....	Outside back cover	Logan, A. J.....	99	Sauter, L. & Co.....	27	Wood, J. R., & Son.....	107
Cuppla, L. A.....	56	Lorsch, Albert, & Co.....	Outside back cover	Schleicher, Schumm & Co.....	64	Zineman, M. & Bro.....	32
Day & Clark.....	16						

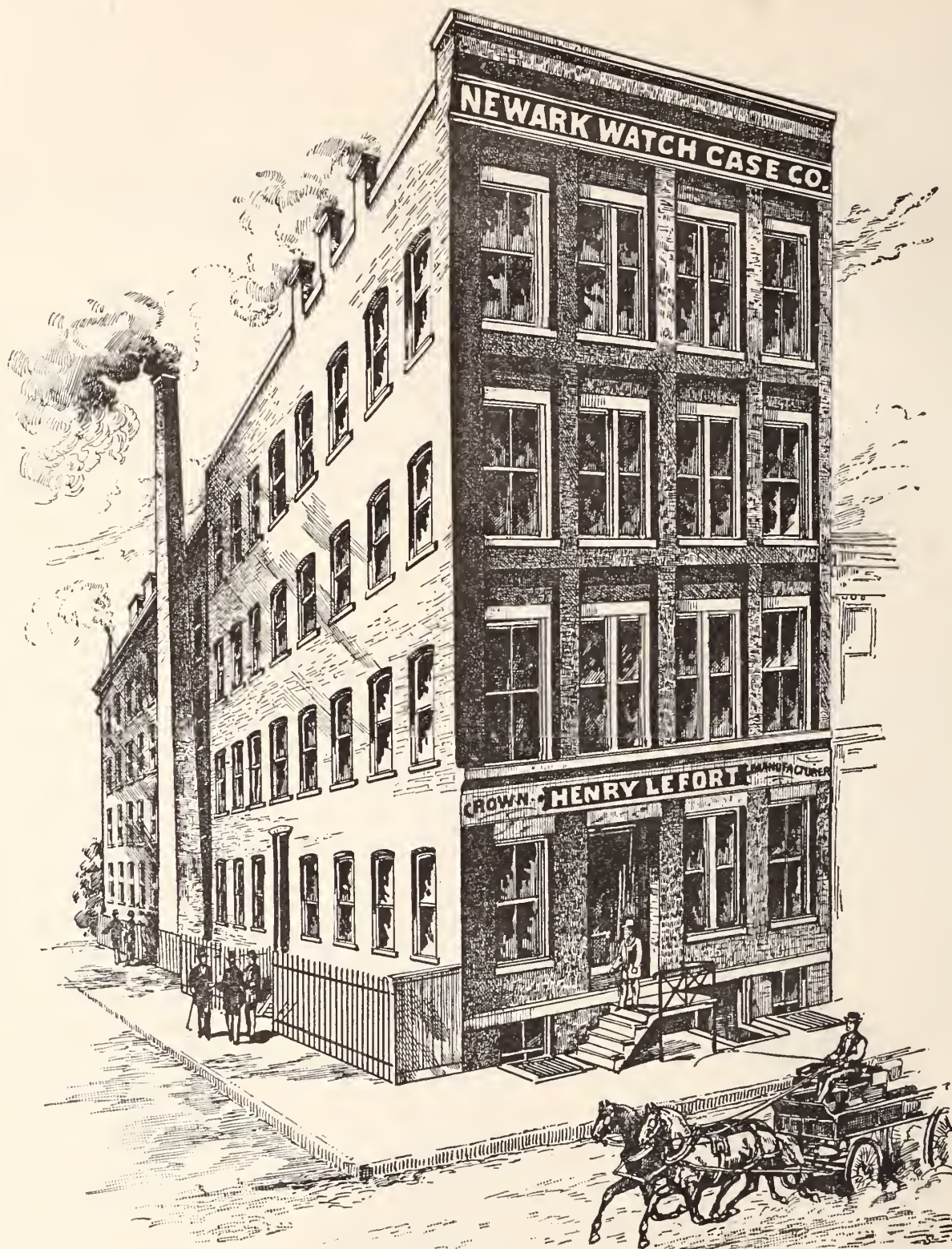

NEWARK WATCH CASE CO.,
MANUFACTURERS OF
GOLD * AND * FILLED * CASES,
60 & 62 ARLINGTON ST., NEWARK, N. J.

HENRY LEFORT, President.

VICTOR NIVOIS, Manager.



THE JEWELERS' CIRCULAR AND HOROLOGICAL REVIEW.

OFFICIAL REPRESENTATIVE OF THE JEWELERS' LEAGUE, THE NEW YORK JEWELERS' BOARD OF TRADE, AND THE JEWELERS' SECURITY ALLIANCE.

It is also the Recognized Exponent of Trade Interests.

A MONTHLY JOURNAL DEVOTED TO THE INTERESTS OF WATCHMAKERS JEWELERS, SILVERSMITHS, ELECTRO-PLATE MANUFACTURERS, AND THOSE ENGAGED IN THE KINDRED BRANCHES OF ART INDUSTRY.

SUBSCRIPTION.—To all parts of the United States and Canada, \$2.00 per Annum, Postage Paid. To all Foreign Countries, \$3.00 per Annum, Prepaid.

All communications should be addressed to

THE JEWELERS' CIRCULAR PUBLISHING CO.,
189 BROADWAY, NEW YORK.

Advertising rates made known on application.

DURING the past five years there has been a growing sentiment in this country in favor of higher technical education. The impression prevails among our leading manufacturers and educators that we have passed through our imitative period and attained that stage of national development where the inner consciousness and aspiration of a people seek expression in the visible creations of art. Foreign designs no longer please; imported designers are little more satisfactory. Manufacturers in all branches of trade are looking around them for the skill that shall devise native forms worthy to supplant the old affectations that once passed current among us. Should it be difficult to find? Talent is plenty among our young people, but it has been permitted to go to waste or develop along false lines. All along the studio has been teaching them that industrial art is an ignoble thing, and that it is more honorable to paint antiques and pretty nothings that nobody cares for particularly than by applying their talents to some of the decorative trades to make the useful beautiful. Art, like all other forms of human effort, must find a market. Our young people who have artistic gifts, therefore, must know that there is a field opening for them in this direction, and the manufacturers on their part must realize the absolute necessity of the artists' co-operation to the future prosperity of their respective industries. Of this co-operation no class of manufacturers stand in greater need than the jewelers, who are engaged in the production of articles of personal use and adornment. All the resources of the artist, the principles of color, form, proportion and fitness, and the liveliest imagination may be called into play in giving variety and charm to their work, and the most progressive manufacturers see this clearly. In the past ten years commendable progress in artistic lines has been made particularly among the silver-workers, but this is only a small beginning. The studio and the shop must be brought together in order to give practical value to the teachings of the one and artistic value to the productions of the other. A movement is now on foot that is destined to supply this want, it is that for the training of the artist artisan, and its object is to provide a school kept constantly in touch with the various trade guilds and associations, where the young of artistic inclinations can receive thorough instruction in the rudiments of art and the application of those principles to particular branches of trade. The man to whose energy and devotion the country is largely indebted for the agitation of this transcendently important question and the awakening of sentiment, both among the youthful aspirants for Apollon's laurel and the manufacturers in all decorative lines, is John Ward Stimson, whose able letter in our "Communications" column will give the reader a more adequate idea of the purpose and character of the work and its present status than anything we can say. Mr. Stimson is endeavoring to turn the tide of art from dilettantism to truth. He would have us forsake the foreign art gods we have been worshipping and return to our own firesides, obey the forms and instincts of beauty that nature has given us as a people, and from these construct a true and national school of applied art—art

GOSSIP OF THE MONTH

A full Index to Advertisements and Table of Contents will be found on Page 5 of this issue.

Arrangements have been made by the publishers of THE CIRCULAR to give its readers a series of handsomely illustrated articles on the Paris Exposition. This series will commence in the June number, and be continued long enough to exhaust all points of interest to the jeweler, the silversmith and the watchmaker.

* * * * *

See the "Sad History of Methuselah & Co., Manufacturers of Filled Gold Watch Cases," page 38.

* * * * *

OWING to the death of our late president, Seth W. Hale, the customary index to Volume XIX was not printed at the beginning of the year. The index has since been prepared, and persons desiring copies of it should send in their applications at once.

that is true and satisfying because it is of the people, by the people and for the people

* *

* *

* *

THE reader will find further evidence of a general awakening among the trade guilds in the letters we publish from D. F. Haynes, chairman of the committee on art and design of the United States Potters Association, and A. L. Tuckerman, manager of the Metropolitan Museum Art School. At their last annual meeting held in Washington, the potters came to the conclusion that their trade was in need of the artist's assistance, and decided to offer prizes for appropriate designs to the pupils of well-known art schools. They appointed a committee to investigate and report upon the matter. After visiting a number of art schools and studying the methods of each, the committee finally settled upon the Boston Museum of Fine Arts, School of Drawing and Painting, the New York Institute for Artist-Artizans, 23d street, New York, and the Philadelphia School of Industrial Art, and have accordingly offered three prizes to be competed for by the pupils of these schools. From present indications it seems highly probable, therefore, that in the near future we shall see some concerted action on the part of the trade associations looking toward a friendly co-operation of the art school and the shop, which it is Mr. Stimson's hope to bring about. The jewelers, the silversmiths, the bronze workers, cabinet makers, weavers, etc., all need the artist-artizan, and all will surely fall into line once the movement is started. In order that the jewelers may not be behindhand in the work, THE CIRCULAR has already undertaken to raise a sum for the establishment of a department of jewelry and silverware designing in the New York Institute for Artist-Artizans, to be under the supervision of a committee of the subscribers.

* *

* *

* *

If you are interested in the Watch Case business read Chas. S. Crossman's "Complete History of Watch and Clock Making in America." The Case industry is now being considered.

* *

* *

* *

THE thaumaturgical lapidaries who for several seasons past have supplied the unsophisticated summer visitor at Narragansett Pier with domestic gems and precious stones to order from the beach went into winter quarters with their establishment at Old Point Comfort, Virginia, and now like sirens fresh from ocean, they cajole the valetudinarians of that celebrated resort into buying their "gems of purest ray serene, the deep unfathomed caves of ocean bear." College presidents, gentlemen of the cloth, white-handed brides, and tourists at random are urged to search along the beach for the white and colored pebbles that abound there, with the assurance that these are valuable gems, native to the place, and can be cut at small cost and kept as souvenirs. Dignified disciples of Bacon and Kent enter into the sport with all the thoughtless ardor of boyhood, and collecting their pebbles, and paying a good round sum for the cutting, they carry away as mementoes of their sojourn a handful of poor Ceylonese moon-stones, artificially colored topazes, or bits of green bottle glass, which the lapidaries have substituted for the pebbles that were brought to them. An expert to whom some of these specimens were shown said that they had the marks of Ceylonese, Oberstein, or St. Marcel lapidaries. The methods of these thaumaturgists will be understood, however, when it is explained that their machinery is of such a dangerous character that they refused \$15 from a customer for the privilege of seeing a single stone which he had found undergo the cutting process. The explanation they offered for this strange proceeding was that they knew too much to endanger the lives of others in that reckless manner, referring doubtless to the attack of "see" sickness that might overtake the observer in watching the operation. The lapidaries of Brighton, England, have at least the decency to do their own "salting" and cutting, strewing the beach with broken bottle glass which,

when waterworn, is found by the guests and brought to the lapidaries to be cut under the name of "Brighton emeralds." In the case of our American lapidaries, however, the material picked up on the beach is never cut, it being so much cheaper to substitute a poor foreign-cut stone. This may seem amusing at first thought, but when one hears of families delaying their departure for weeks to search for pebbles, and hotel chambermaids investing their savings in these bogus finds, it becomes more serious, and it is time these imposters ceased their fraudulent traffic.

* *

* *

* *

The serial on the "Marfels Watch Collection" will be completed in the June issue.

* *

* *

* *

JEWELERS in quest of new ideas in window dressing can get a valuable hint from an innovation recently tried by a Chicago firm. Natural flowers, into which were stuck solitaires, pins, brooches or shirt studs in appropriate shapes, were arranged in the window, the diamonds appearing like glistening dew drops fresh fallen, on the glowing bed of flowers. The effect was decidedly novel and proved a great drawing card. During Eastertide a New York retail firm had a bed of lilies sprinkled with diamonds set in the show window and attracted crowds by the appropriateness of the display. Much depends in these busy days on the power of attracting the attention of the public, and there is no better way to do it than by studying up novel window displays, changing them from time to time, and having them written up in local newspapers.

* *

* *

* *

EXCELSIOR is on our staff again. Every one of his articles is worth a year's subscription to any watchmaker.

* *

* *

* *

THE paragraph in our last issue in regard to the care of jewelry and the means employed by a western retail firm to impress the matter upon the minds of their customers, brought a number of letters to the CIRCULAR office asking for further information. The device adopted by the western house was a little pasteboard folder in lieu of the ordinary repair check, a capital thing to impart the desired knowledge, as it of necessity had to be preserved and the reading matter could hardly escape notice. Other uses for these short items might easily be found. They might be printed on wrapping paper or on the leaflets frequently distributed for advertising purposes. In style they are practical and simple, such as would be read with interest by almost any lady. Considering its importance it is rather surprising that this subject has not been more thoroughly ventilated by the trade. The "Hints" referred to are reprinted in full below, in the hope that they may be found suggestive to others of our readers who know how disagreeable sometimes are the consequences of a customer's ignorance of these things:

First. Jewelry should not be thrown in a case promiscuously, as it will become scratched or scarred.

Second. Wash frequently, using Jewelers' "Silver Polish" (as directed), or soap and warm or hot water, and rinse thoroughly in clean warm or hot water and dry with a piece of soft cloth, an old handkerchief, a piece of canton flannel or chamois skin. The polishing surface should be rubbed carefully with clean canton flannel or chamois.

Third. Diamonds should not be worn or packed away so that one stone may come in contact with another, as they may thus become "scratched" or "nicked." If carried in chamois bags, divisions should be made for each article. Diamonds become electric from the friction in wearing, and the back of the stone will become covered with a dust or lint attracted thereby, which destroys the brilliancy. They should be washed the same as other jewelry, only more frequently. Diamonds must be kept perfectly clean to be brilliant.

Fourth. Diamond mountings should be examined frequently, to see that the clamps do not wear and let the stone fall out, especially in finger rings.

Fifth. "Solitaire" Pearls can be washed the same as other jewelry, but not with hot water. "Strung Pearl" jewelry will be greatly improved by washing it

ALFRED H. SMITH & Co.,**DIAMONDS,**

182 BROADWAY, NEW YORK.

LONDON:

33 HOLBORN VIADUCT.

CHICAGO:

123 STATE STREET.

Attention is invited to the following importations:

Matched Rubies.

A pair of superbly matched rubies, extra choice in color, nearly $2\frac{3}{4}$ carats and very showy for the weight. Price, \$ G X E C.

Ruby, $3\frac{1}{2}$ carats.

One round ruby of good color and extraordinary brilliancy and perfection. Price, \$ G X E C.

5 carat Diamond.

A round blue-white gem—absolute perfection. We believe it to be the finest stone of the weight for sale in the United States. Price, \$ I C E E.

Pearl Necklace.

55 pearls, 335 grains. A necklace of remarkable brilliancy. Price, \$ A C I E.

We shall advertise from time to time goods of especial rarity, putting the prices in cipher, a key to which we will forward on application.

Respectfully,

ALFRED H. SMITH & CO.

in warm milk and water, and rinse in clean warm water. Other stone jewelry is subject to the same rules as diamonds.

Sixth. Pearls become injured or discolored by the accumulation of grease, soap, or similar substances collecting around the clamps and under the setting.

Seventh. In using a brooch, do not make a lever of the pintong, with the joint as a fulcrum, as it will be pretty sure to break; but push the pin straight forward, and be sure the pintong has a sharp point, with a long, tapering shoulder. If it has a heavy, blunt shoulder, it will be very difficult to force it through the cloth, and will be apt to bend or break.

* *

* *

* *

Call the attention of editors of your local papers to "Elsie Bee's" "Rambles Among the Jewelers," and have the items reprinted. It will increase your trade.

* *

* *

* *

PROPOS of the subject of the care of jewelry a manufacturer gave the editor a good illustration the other day of what might be termed the "personal equation" in this question of the wearing qualities of jewelry. Many years ago, he said, when enameled box and glass brooches were worn, the firm with which he was then connected used to have many returned during the summer season with the enamel missing on the upper side. He noticed how uniformly the break occurred on the upper side, and putting this together with the fact that the repairs came back in the summer season, he drew the conclusion that the owners of these brooches had perspired freely and the enamel had been gradually loosened by the alternate action upon it of the saline perspiration of the body (the chin frequently resting on the brooch), and the cool draughts of air. Enamel and gold being of different expansibility, these sudden changes of temperature loosened the enamel, until finally pieces of it dropped out. One day a brooch came to the shop to be repaired, which threatened to upset this carefully elaborated theory, for the enamel had disappeared from the under instead of the upper side, but on investigation it was found to belong to a left-handed lady, and thus the soundness of his reasoning was proved beyond a doubt. This was no fault of the manufacturer. The defect, if such it could be called, was inherent in the nature of enamel, and could scarcely be obviated when the brooch was exposed to the heat of the body. A knowledge of such facts is helpful to a jeweler, and will often enable him to account satisfactorily for apparent defects of workmanship.

* *

* *

* *

Opticians or retail jewelers that do optical business cannot afford to lose Dr. Bucklin's serial treatise on "Mechanical Ocular Defects," now appearing.

* *

* *

* *

THE CIRCULAR now has about 150 retail jewelers throughout the country engaged in the work of popularizing jewelry through the "Fashions in Jewelry," advance sheets of which are sent out every month to be reprinted in local papers. The newspapers, everywhere, have shown a ready willingness to reprint these items when their attention has been called to them, and there is scarcely a town in this broad land where there is not at least one jeweler influential enough to secure their publication if he will only undertake it. Think of the resultant effect, slow and sure though the process be, if thousands of newspapers were regularly to print these items on jewelry fashions. It would not take long to turn the tide of popular favor toward the jeweler, and turn it more strongly than ever before. The caprice of fashion leaders would be neutralized before such overwhelming testimony. Printer's ink is a power that can easily be underestimated, but can hardly be overestimated in the propagation of reforms and opinions. The thoughts of the average American citizen to-day, are moulded by the newspapers they read, and the more attention paid to jewelry in those papers, the more certain will the readers get the impression that jewelry is fashionable, and proceed to gratify their love of ornament without fear of giving offense to Mrs. Grundy. Any retail jeweler who will

undertake to have these items published in the newspapers of his town, can have the advance sheet forwarded to him every month by sending in an application to the CIRCULAR office.

Congress of American Nations.



THE ACT passed by Congress last year, authorizing the President to invite the governments of the Republics of Mexico, Central and South America, Hayti, St. Domingo and the Empire of Brazil to join the United States in a conference to be held at Washington, is a step in the direction of solving the problem of more intimate commercial relations between the United States and those countries. It will be remembered that a commission appointed by Congress considered this problem for some time several years ago, and it is a result of the work of that committee that this "Congress of American Nations" has been called. The President has appointed the following named gentlemen to represent the United States at this conference: John B. Henderson, Missouri; Cornelius M. Bliss, New York; William Pinckney White, Maryland; Clemence Studebaker, Indiana; T. Jefferson Coolidge, Massachusetts; William Henry Trescott, South Carolina; Andrew Carnegie, Pennsylvania; John R. G. Fitkin, Louisiana; Morris M. Estey, California; and J. H. Hanson, Georgia. The governments of the several nations mentioned have signified their willingness to be represented, and the congress will assemble in Washington some time in October. Eighteen nations are expected to be represented, and it is believed that the sessions will extend for at least three months.

The objects of this congress are explained to be the formulation of some plan of arbitration for the settlement of disagreements or disputes that may hereafter arise between them; for considering questions relating to the improvement of business intercourse and means of direct communication between these countries; to encourage such reciprocal relations as will be beneficial to all; and to secure more extensive markets for the products of each of these countries. The scope of the deliberations of this body is a wide one, and will include questions relating to the formation of a customs union, the establishment of common silver coin, steamship communication, and the bringing about of closer commercial intercourse between these countries. A committee of business men in Washington is interesting itself in this congress, and is attempting to make arrangements for an exposition of the natural and industrial resources of the three Americas, such exposition to be held during the first six months of 1892. This committee has decided to invite all the boards of trade throughout the United States to designate a committee of their members to act in concert to further the objects of this American exposition. Congress will be asked to make a liberal appropriation for it, and other nations interested will contribute proportionately.

The industrial interests of this country would be very greatly promoted if the southern portion of the continent could be opened to them upon such terms as would enable our manufacturers to compete with those of other countries. At present England and Germany virtually control the markets of Mexico, South and Central America, mainly on account of the advantages of transportation afforded them by their several governments. The trade and traffic of this entire continent by right belongs to the United States, but the indifference shown to our commercial interests by our own government has given the advantage to other countries. It is the purpose of the coming congress of American nations to so present the case to our government and to the people as to secure a remedy for this condition of affairs. Everyone familiar with the industrial interests of the United States is aware that what is most wanted to secure their welfare and continued prosperity is an increased outlet for their productions. New markets for the disposal of their goods are required, and these cannot be obtained while foreign governments are continually increasing the facilities for transportation and encouraging their manufacturers to build up an export trade, while our own government sits idly by and with indifference sees the trade that should belong to us monopolized by others. There is a wide field for enterprise in the regions lying south of the United States, and Yankee enterprise and Yankee activity may be counted on to reap its share of the harvests there to be gathered, provided they can be permitted to do so on terms of equality with other competitors. The coming "Congress of American Nations," and the proposed exhibition of the products, industrial and otherwise, of the several nations of this continent, should enlist the earnest sympathy and support of every citizen of this country.



* A Complete History of Watch and Clock Making in America.

[By CHAS. S. CROSSMAN.]

Number Thirty-Three.

Continued from page 78, April, 1889.

WATCH CASE MAKING.

MICHAEL H. CRONIN

SERVED HIS apprenticeship in the case business with Waitt & Crocker, of Philadelphia. He afterward started in business for himself in New York, but failed about 1874. Returning to Philadelphia he entered the employ of H. G. Gill, at 618 Chestnut street. In May, 1878, Mr. Cronin commenced the manufacture of gold cases on his own account, being located in the same building, at 618 Chestnut street, and receiving some financial aid from friends. He had good machinery and did good work, but failed to make it pay.

In November, 1882, the factory was sold at sheriff's sale to satisfy a claim against Mr. Cronin. Muhr & Son bought the tools and machinery and ran the factory under the supervision of James Fleming.

In January, 1883, the Howard Watch Case Co. was started at the corner of Seventh and Jayne streets, with Mr. Cronin as superintendent. The capital stock, according to the charter, was \$25,000, but less than \$2,000 was ever paid in. The charter of the company was for the manufacture of gold and silver cases, but no silver cases were ever made. The concern lasted only about a year. Alfred Spear, a bullion dealer, of New York, who claimed that Mr. Cronin owed him for gold, was hovering around, trying to attach anything that he could prove belonged to Mr. Cronin. The enterprise finally died out for want of capital and push. The tools were bought by Michael Brennan, who, in February, 1884, started a small case factory at 929 Filbert street, and put Mr. Cronin in as superintendent. Mr. Brennan was ignorant of the case business.

Mr. Cronin was finally decoyed by a letter to New York City, arrested on Mr. Spear's charge and lodged in Ludlow street jail in that city. The shop in Filbert street ceased operations, seventy-two cases being the total product. The tools were sold and business wound up.

BOOZ & CO., SUCCEEDED BY THE NATIONAL WATCH CASE COMPANY.

The present National Watch Case Company is composed in part of the firm of Booz & Co. This firm was established in July, 1868, by Albert Booz and Thomas B. Hagstoz. Both of these gentlemen were practical workmen, Mr. Booz having been in the employ of Tracy & Co. since 1856. The firm name was Booz & Hagstoz, and they located at 108 South Eighth street, where they did a jobbing and repairing business, and commenced to manufacture special cases to order, both gold and silver. In 1871 Samuel B. Thomas was admitted to the partnership and the firm became Booz, Hagstoz & Thomas. The business increased slowly but surely, and in 1875 when Mr. Hagstoz withdrew from the firm they were employing twenty-five men, and turning out from thirty-five to forty cases per week. The firm now became Booz & Thomas, and continued so until Mr. Thomas, wishing to retire from business, left the firm in

1882. Frederick Schober was then admitted, and the firm name of Booz & Co. was assumed, which was retained until 1888, when the business of the firm was merged into the National Watch Case Company, in conjunction with that of A. Humbert & Co.

The firm made gold cases for American movements only in 10-k., 14-k. and 18-k., a larger portion of these being of the style known as flat back. Their business was mostly in fancy engraved and special work, rather than in the regular line of cases. They also manufactured plain rings to a considerable extent. Of this firm it may be said they have always endeavored to keep up a high standard of workmanship.

MUCKLE & ZESINGER.

This firm of case makers, composed of E. A. Muckle and Rudolph Zesinger, carried on business in Philadelphia for about seven years.

They commenced in 1865, being located at 44 South Third street. In 1867 they removed to 140 South Third street, at the corner of Harmony Court, which has been the resort of so many case makers.

From here they removed in 1869 to 216½ Walnut street, where they carried on case manufacture until 1872, and then abandoned it.

BELL & LUNGREN

Manufactured watch cases in Philadelphia for a period of about three years. The firm was composed of William Bell, who had worked as a journeyman with his brother-in-law, T. E. Harper, of the firm of Harper & McLean, and Charles Lungren, who had worked as a journeyman with Reese S. Peters. They commenced operations at 712 Chestnut street in 1864, but the following year they removed to the corner of Second and Chestnut streets. They manufactured only silver cases. The shop was run on a small scale and but few hands were employed. Mr. Bell died in 1866, and after running the shop alone for a year, Mr. Lungren sold the tools and machinery to various parties and gave up the case business entirely.

THE KEYSTONE WATCH CASE CO., INCLUDING SOMETHING OF JAMES BOSS AND HIS SUCCESSORS, AND THOSE WHO COMPOSE THE COMPANY AT PRESENT.

In writing the history of this very successful company, it is necessary to go back a little over the struggle of those who were previously connected with the business, and first of all we will speak of James Boss, whose "patent filled cases" were the foundation of the company's success. He was a native of Maryland, but came to Philadelphia at an early age and served an apprenticeship at the gold pencil trade. Afterwards he entered the employ of R. S. Peters & Bro. in 1851, and subsequently was in partnership with each of them separately (see R. S. Peters and Randolph Peters). But we find Mr. Boss, after a varied business experience, alone in 1860, carrying on a business in Cherry near Sixth streets. He had patented his filled case previous to this, but the trade had many misgivings about taking hold of it, and he really had a hard struggle to make ends meet. Finally in 1864 he sold out to John G. Stuckert and removed to his former home in Berlin, Maryland, where he resided until his death recently. His successor tried to make a success of it and worked along until 1875, at which time he managed to find sale for his production, which was about 18 cases per week. At this time these cases came to the special notice of Chas. N. Thorpe, a salesman in the employ of Morgan & Headly, whose factory was in the same building at 618 Chestnut street, and who had a large trade among the retail jewelers throughout the United States. He believed there was money in them if they could be gotten before the public.

Mr. Stuckert's health was not good and he was anxious to retire from business. Mr. Thorpe therefore began to look around for a partner. He found one in T. B. Hagstoz, of the firm of Booz, Hagstoz & Thomas, he withdrawing from that firm and assuming the

practical management of the new firm of T. B. Hagstoz & Co., of which Mr. Thorpe became the business manager.

They met with success from the start, and were obliged the year following to remove to larger quarters in the Public Ledger building, where they purchased the business of E. Tracy. They doubled their business year by year, and in time attracted the attention of Geo. W. Childs through the employment of female labor, which Mr. Thorpe was a firm believer in, and, as is well known, Mr. Childs has always espoused the cause of woman's work. Mr. Childs made a proposition to the new concern to increase their capital and build a large factory in the northern portion of the city, becoming in 1880 their special partner, the firm being at this time Hagstoz & Thorpe, with George W. Childs as special partner. The first building erected in 1880 was soon found to be too small, for with increased capital the new concern took a stride ahead and in 1882 another large building was added, and the firm began to manufacture both gold and silver cases in addition to their line of Boss filled cases.

In July, 1883, Mr. Hagstoz withdrew from the firm and engaged in the diamond business under the name of T. B. Hagstoz & Co., and the case business was continued under the firm name of C. N. Thorpe & Co., C. N. Thorpe managing, and George W. Childs special partner. In December, 1885, the business was formed into a stock company, C. N. Thorpe being the President and General Manager, Howard L. Roberts, Secretary and Treasurer, he having been with the company for many years and having the management of the books and finances. Geo. W. Childs retained his interest. Thus from a small beginning in 1875, of a concern employing only 13 hands, has grown this company, now in the front rank of case manufacturers, employing 1,050 hands and manufacturing 1,500 cases per day.

LOW & COURVOISIER.

This firm was composed of J. F. Courvoisier, who came to this country in 1848 at the age of seventeen years, and worked for C. Jacot until 1850, at which time he entered the employ of Harper & McClelland. He remained there until 1853, when a partnership was formed between himself and a Mr. Low and Mr. Ducret, under the firm name of Low & Courvoisier. They located at 76 South Third street, where they did a moderately successful business until 1864. At this time the firm dissolved, Mr. Courvoisier removing to Carlstadt, N. J. There he was employed as a foreman in the silver case factory of Fotenbach Bros. In 1863 he went to New York City. He was there connected with the New York Watch Case Company until 1877, when he removed to Milford, Pa., forming a partnership there with A. Berthoud, the firm being Courvoisier & Berthoud. The firm did for a time quite an extensive business, making both gold and silver cases until 1883, when a dissolution took place, Mr. Berthoud retaining the business, which he still carries on. Mr. Courvoisier at this time removed to Port Jervis, N. Y., and established a gold case factory, making all sizes and grades of gold cases.

(To be continued.)

What Waltham is Doing for the Watchmakers of the World.

BY WENDEL F. FOSTER.



THE Waltham Watch Tool Company are the successors to the Hopkins Watch Tool Company, which was originated in 1874, and are pleasantly located on the north side of Charles River, on Bedford street, and in the immediate vicinity of the new United States Watch Factory. Their present factory, built and owned by them, is a substantial and convenient three-story building, 25x60 ft., with boiler-room in the rear, and, for the light-running machinery used,

they find an eight H. P. engine sufficient, and the whole plant is admirably planned and is equipped with the best special machinery.

The proprietors of this establishment are Charles E., Fred. D. and Edmund F. Van Norman, sons of C. Hopkins Van Norman, the originator of the many valuable patents which are so well known to the trade. They are young, active men, and Chas. Van Norman, the superintendent, has had the benefit of much practical experience, gained while acting as superintendent of the former company, while the many improvements made since the new company was formed, show him to be fully posted in all the requirements of their business.

The many patents and special tools which have proved acceptable to the trade, and also the valuable services of Hopkins Van Norman, are still retained by the present company.

With the help of the sixteen men now employed, about one lathe per day, besides several other tools, can be produced.

The small No. 1 lathe, with 6½-inch bed, has been discontinued, and the sizes now manufactured are Nos. 2, 3, 4, and a bench lathe with 28-inch bed and 7¼-inch swing. The No. 3 is the popular size, and from the first start of the Hopkins Company proved itself to be the best all-round size, being large enough to run steady, and at the same time running light enough for the most delicate work required. Its dimensions are similar to the Whitcomb 1½, and more of this size are built than all the others combined.

Beside these mentioned, and "3x4" is made, being a 3-size lathe with a 4-size spindle, swing, etc., which is becoming popular in certain localities. The form of spindle bearings used in these lathes are similar to those of all first-class American lathes, and which are supposed to have originated in the works of the American Watch Company.

None but the best quality of material is used, and a series of standards insure perfection of work. With a boring machine designed by Chas. Van Norman, the able superintendent of the present firm, the lining of the head and tail-stock to the bed-piece are brought to an absolute standard.

This company are noted for the numerous attachments which make their lathes so popular, among which may be mentioned a universal head, which has many advantages, and which is covered by letters patent; also a slide rest, for which are claimed rigidity, and several features not combined in any other rest.

The combination jewelers rest and saving tail-stock recommends itself to any who may wish to economize and purchase one tool combining the features of the above with those of a plain tail-stock.

Among the other attachments are a rotary pivot-polisher and taper-grinder, rounding-up tool, wheel-cutting and milling fixture, filing fixture for squaring barrel arbors, etc., and many other devices too well known to need any detailed mention here.

In addition to the ordinary split or wire chucks they make the "Hopkins" adjustable chuck and the "Gem" pivoting chuck, whose merits must be tried to be fully appreciated. The latter chuck is a complete substitute for wax, and if some of our old-fashioned workmen who will never buy a "new-fangled" lathe would try one of these chucks they could "turn out work" easier and cause less "mental suffering" than at present.

Nearly every watchmaker has seen or used one of Hopkins' watch-case tools. It is a very simple tool, and if rightly used will close or free a case so it will open or shut properly.

The Hopkins foot-wheel which was formerly manufactured for the old company is now built by the new firm in the same careful way as their other work, which, to all who know it, will be sufficient commendation.

The Waltham Watch Tool Company are at present being represented on the road by Wm. Caughey, for many years an adjuster with the American Watch Company, and whose mechanical ability well fits him for his present duty of proving the merits of their tools among the watchmakers of the country.



[FROM OUR SPECIAL CORRESPONDENT.]

HALL MARKING PRO AND CON—ITS PROVISIONS AND CURRENT OPINIONS ON ITS MERITS.

LONDON, April 12, 1889.

I do not remember any period, during the past twenty years, at least, in which the members of our jewelry and watch making industries have so energetically and so widely discussed the supposed merits and demerits of the principal questions of the day as they are doing at the present time. The general practice has been that no matter how important the subject, the discussion of it has been confined to a few only of the more active members. There are, however, one or two topics well to the front just now that you may hear debated in almost any town throughout the kingdom. I have been moving about a great deal since my last letter to you, but everywhere I have been I have heard something, and in many places something new (to me, at least) about the Merchandise Marks Act and the hall marking of gold and silver plate. These regulations affect those of your citizens who are sending, or who contemplate sending, plate, jewelry or watches to this country, and therefore some remarks upon them may not be uninteresting. I take it that your readers are acquainted with the broad fact that we are now discussing the restriction or abolition of compulsory hall marking of gold and silver goods. I have had opportunities of hearing the opinions of manufacturers, factors and retailers. I have heard both sides of the question urged as desirable, but I have no hesitation in saying that the concensus of opinion is largely in favor of compulsory marking.

If it was left to the members of the trade to vote on the subject, hall marking would, in my opinion, be retained by a vast majority. As in everything else, the feelings of the consumer in reference to the matter should be taken into consideration. Without an imperative hall mark, how is a purchaser to be assured that the article he is buying is the genuine article it is represented to be? Articles of 22-karat and of 9-karat are described as "gold." How far will impurities be permitted in silver articles before they will be denied the description "silver?" The truth is, that hall marking is a system of guarantee to the purchaser which, in my opinion, the public will be very loth to be deprived of.

I have heard country retailers assert that they, as far as they can, buy goods with the hall mark, because their customers look for the mark before they decide upon buying. While being very satisfactory to the consumer, the mere fact of an article being hall-marked relieves the vendor of any responsibility in the way of a guarantee. Our hall mark is understood by everyone at home and abroad—it has done more than anything to establish the value of British goods, and I have not heard any very sound argument in favor of its abolition. There are some who seek to compromise the matter. They do not insist on the abolition of hall marking altogether—they propose a system of voluntary marking. They are willing to allow those who wish to have hall marked articles to buy them, but they want permission to make articles of whatever quality they like. That is just the concession that those who sell the articles to the public are not likely to agree to. Manufacturers who object to have their silver goods marked with their true standard value, lay themselves open to the suspicion that without the compulsory mark their goods might not always be of the standard claimed for them. The members of the Sheffield Silver Trade have memorialized the Chancellor of the Exchequer against any alteration in the law of compulsory hall marking. Their contention is that the market would soon be crowded with goods made from silver of an inferior quality, and that

the public would thus be subject to deception. They mention the electro-plate trade, where the absence of any fixed standard leads to instances of gross deception. We have become accustomed to a recognized legal standard for silver goods, while there has never been any standard fixed for plated goods. The public are aware of these distinctions, and so far as I am aware, have not expressed any wish for the abolition of the official guarantee of the quality of the silver-ware they buy.

There exists an extraordinary anomaly between the hall marking in the goldsmith's trade and the silversmith's. The laws relating to the former are quite as stringent as those of the latter, yet until comparatively recently they have been almost imperative. The Goldsmith's Company did not take the trouble to enforce the laws, and we suppose it was not the duty of anyone else to do so. At one time the Goldsmith's Company attached great importance to the hall marking of gold articles. The evidence of this is in the form of oath required by the company from every apprentice who, having completed his time, applied to take up his freedom at the hall. He was required to swear that "True gold and silver he would work and cause to be worked, so that the gold or silver he should work and cause to be worked should be as good as one of the standard appointed for wrought plate." Having exacted this oath the Goldsmith's Company do not appear to have taken any steps to enforce its observance. The marking of gold plate was, in effect, perfectly voluntary. But it is very different now, and the very great increase in hall marking without any special efforts to enforce it, shows what great importance is attached to the practice by both buyers and sellers. Jewelers especially are manifesting an increased desire to adopt the hall mark—without this indication of quality I do not see how we can have any generally accepted standard of value. Such a mark is of the greatest utility, not only to protect the purchaser, but also to protect the manufacturer, who honestly supplies articles that are truly what he represents them to be, against the unequal competition of the maker who uses the least possible quantity of gold and silver.

The Merchandise Marks Act has been much in evidence lately and is so now. It is a very clear and comprehensive act and deals with every one of our industries. I need only make such reference to it as concerns the daily business of your readers.

The definition of "trade description" and "false trade description" are important to trades generally, and requires to be carefully studied so that offences under the act may be divided. The expression "trade description" has a special bearing upon the marks required upon foreign watches and jewelry. This expression is defined as meaning any description, statement or other indication, direct or indirect, (1) as to the number, quantity, gauge, measure or weight of any goods; (2) as to the place or country in which any goods were made or produced; (3) as to the mode of manufacturing or producing any goods; (4) as to the material of which any goods are composed, or (5) as to any goods being the subject of any existing patent privilege or copyright. The use of any figure, word or mark which, according to the custom of the trade, is commonly taken to be an indication of any of the above matters, is deemed to be a "trade description." The expression "false trade description" means a trade description which is false in any material respect as regards to the goods to which it is applied, and includes every alteration of a trade description, whether by additional defacement or otherwise, where that alteration makes the description false in a material respect, and the fact that a trade description is also a trade mark, or part of a trade mark, does not prevent such description being a "false trade description" within the meaning of the act. The addition of figures, words or marks calculated to lead persons to believe that the goods are the manufacture or the merchandise of some other person, or that the goods are of a different size or quality to what they truly are, is also a false trade description within the meaning of the act.

There is a section of the act—section 7—which specially brings

watches within the scope of the operations of the act. Perhaps the effect of this section may be better shown by an illustration than by an argument. A case has recently been brought before one of the city of London police magistrates, in which a well-known watch-maker in the city was summoned for infringing the act by unlawfully selling a watch to which had been applied a "false trade description." The prosecution was instituted as a test case by the London Watch Trade Association, whose members, and especially the workmen engaged in their business, consider they have been seriously injured in their trade by the sale in this country of inferior foreign watches under the description of English manufactured goods. There was no imputation that the defendant had himself applied the false description to the watch. He was admitted to be a respectable tradesman of long standing in the city. It appeared that some members of the Association saw in the window of defendant's shop a silver watch with the words "English Lever Watch Company" on the face of it. They purchased it there and then for the sum of £1 18s. 6d., and on examining it found it was a very inferior kind of foreign made watch. It bore the Swiss hall mark and was marked inside "expressly examined," and on another part "patent lever jeweled," and on the works were the words "chronometer balance." It was shown that the words "patent lever" were well understood in the trade—but this watch was in no sense a lever watch—the "jewels" were imitations and the chronometer balance was useless. It was urged that no one could expect an English lever, with all the additions named for so small a sum—but that was not the point. The only point submitted to the magistrate was that a foreign watch was exposed for sale, described as of English manufacture. It was proved that the watch came into stock in 1885, long before the act was passed; the defendant had not been at business for some time; he admitted that this watch had been sold by his assistant, but he explains that he was not aware that such watches were being sold. As this was the first case of the kind connected with the watch trade the magistrate imposed a mitigated penalty of £5, and £20 costs. I have given rather full details of this case as an illustration of the effects of a false description. If watches sent to this country are discovered by the customs authorities to have a "false description" upon them they are liable to be forfeited. The same applies to every other article that bears a trade mark or description. VIGILANT.

Obituary.

SMITH OWEN.

Smith Owen, of the firm of G. & S. Owen & Co., one of the oldest manufacturing jewelers in the country, and a venerated and wealthy citizen of Providence, died suddenly on Wednesday, April 17, in the 80th year of his age. The life of Mr. Owen is essentially the history of the house he and his brother founded and built up. Smith Owen was born in Gloucester, R. I., in 1809. The family removed to Providence when he was quite young. He learned the trade of jeweler and chaser of Joseph Veazie, and on June 23, 1834, in conjunction with his brother George, he formed a partnership with Alexander Hunter, the firm name being Hunter, Owen & Co. Their first shop was located in the attic of a building on Steeple street, occupied as a silverware factory by Jabez Gorham, the founder of the Gorham Manufacturing Company. At the end of six months Mr. Hunter retired from the firm, the brothers continuing the business under the style of G. & S. Owen. On the first of April, 1836, the firm moved into a one-story wooden building which they had had erected on the opposite side of Steeple street. In 1847 the wooden building was moved to Canal street, where work was continued during the erection of a larger shop on the old site. In 1856, requiring still larger accommodations for their business, they moved to the second floor of the Mathewson & Allen Building, where they

remained 17 years. In 1873 they occupied the fourth floor of the six-story building at the corner of Snow and Chapel streets, which they had erected for jewelry shops, and in which they are still located.

For 20 years after the commencement of business, Smith Owen kept the books, sold the goods and worked in the shop at chasing. He sold all the goods until the firm opened an office in New York in 1857, and after that he still continued to sell in New England until 1870. For the first six months, principally plated goods were produced. The firm then commenced to introduce solid gold goods, in which it has almost wholly dealt to the present time. The firm in its career has manufactured all varieties of jewelry and has striven to employ the best material and the finest workmanship.

The style of G. & S. Owen remained unchanged until 1858, when other partners were admitted, and the name became G. & S. Owen & Co. In 1872 James P. Snow was admitted into the firm, and has since had entire charge of the business in New York, and in 1875 Charles E. Westcott became a partner and has had charge of the factory at Providence, the Messrs. Owen having, since the entrance of these gentlemen, taken no active part in the business, although they were often to be found at the factory and were always interested in the details of the business.

During the long career of the firm activities and depressions of business have been experienced, and while other houses were compelled to surrender to the inevitable of the panicky times of 1861-1865 and 1873, it withstood the overwhelming storms, and to-day stands upon a firmer foundation than ever. A remarkable feature connected with the history of the house is the length of time a number of its employes have remained in its constant service. Nine have been in its employ for from 25 to 40 years and three from 15 to 25 years.

In the death of Mr. Owen the city of Providence loses an eminent exponent of a trade that has materially contributed to its wealth.

By a most sorrowful coincidence, his beloved wife died but three days previous to his decease, and his eldest daughter three days after. One daughter alone remains of this well known family which less than two weeks ago consisted of four members.

DAVID B. CHURCHILL.

A familiar and respected figure has passed from our midst. After a prolonged illness, David B. Churchill, surrounded by his family and friends, died at his home, 524 Stuyvesant street, Brooklyn, on the night of April 9. The immediate cause of his death was heart complaint, with which he had been affected for some six months past.

Mr. Churchill first saw the light in the village of Woodstock, Vt., on December 20, 1838. As a youth he was apprenticed to a Providence jeweler, and soon acquired a thorough knowledge of the business, in which he remained until his death, with the exception of the period spent in the war for the preservation of the Union. In 1862 he enlisted as a private in the 3d regiment of the R. I. Volunteers; but his promotion was rapid, and at his discharge, with the title of captain, he was awarded a testimonial of honor.

Returning to Providence he formed a partnership with a Mr. Chace under the style of Churchill & Chace. Mr. Chace afterward retired, and the firm style became Churchill & Co. November, 1883, to January, 1885, he was connected with A. S. Gardner & Co., leaving that firm to become the representative of G. K. Webster, with whom he remained until his decease.

Perhaps no member of the trade enjoyed so enviable a reputation for sterling integrity and amiable disposition. He was a member of the Jewelers' League and the Royal Arcanum. He leaves a wife and a son of eight years of age.

WHEELOCK P. BINGHAM.

One of the most prominent figures in the jewelry trade of the country passed away at midnight of the 31st of March in the person of Wheelock P. Bingham, of the firm of Bingham & Walk, of Indianapolis, Ind. His illness was Bright's disease, and was of a long and painful nature. He was 53 years of age, and had for 30 years been identified with the jewelry trade of Indianapolis, coming originally from Massachusetts, the State of his birth, and starting in business as W. P. Bingham & Co. He soon became the leader of the trade in that city. At his death he was a prominent member of Christ Church, and was a Mason of high degree. He leaves a wife and five children.

ITIES BY REFLECTION. EDWARD A. TRAPP, Brooklyn, N. Y. Filed September 6, 1888. Serial No. 284,748. (No model.) In this device there is a main tube having a telescope at the upper end and a branch tube extending from the main tube, combined with the weighted movable reflector at the union of the tubes, the reflector being at equal angles with the axial lines of the tubes, with a means of producing illumination adjacent to it.

Design Patent No. 19,045—BRUSH OR MIRROR BACK AND HANDLE. WILLIAM M. WELLING, New York, N. Y. Application filed February 23, 1889. Serial No. 300,948. Term of patent 7 years.

Issue of April 16, 1889.

401,449—CLOCK.—ARTHUR JUNGHANS, Schramberg, Wurtemberg, Prussia, Germany. Filed February 18, 1888. Serial No. 264,846. (No model.) In this invention is combined with a clock mechanism, a rotary drum provided with a groove, an automatic figure having a movable arm fastened to a shaft provided with a bent portion and a pivoted rod, one end of which is adapted to engage with bent portion, the other end of the rod being in position to engage with the drum in the groove.

401,682—ELECTRO-THERAPEUTIC SPECTACLES. CASPAR BRUST, Schlossgasse No. 6-2, Hadhausen, Munich, Germany. Filed February 14, 1888. Serial No. 264,031. (No model.) Patented in England October 27, 1885, No. 12,921. This is a device for imparting electricity to the human body, and consists of a spectacle frame formed of copper and carrying zinc plates or strips secured thereto, of a coating of lacquer, varnish or the like.

401,697—TIMEPIECE DIAL. MARTIN V. B. ETHRIDGE, Boston, Mass., assignor of two-thirds to John Swann, New York, N. Y., and Henry E. Waite, West Newton, Mass. Filed June 20, 1888. Serial No. 277,634. (No model.) In this timepiece dial is combined, with a series of radial rotary spindles carrying turnstiles, a disk notched and a pin or arm projecting from the disk.

Trade Mark Patent No. 16,494—WATCHES. JULIAN GALLET & Co., New York, N. Y. Application filed February 28, 1889. Used since May 22, 1888. "The word 'Patriot.'"

Trade Mark Patent No. 16,495—ARTICLES OF JEWELRY AND ORNAMENTATION FOR PERSONAL WEAR. HAMMOND TURNER & SONS, Snow Hill, Birmingham, County of Warwick, England. Application filed June 7, 1888. Used since February 8, 1866. "The representation of a lion."

Issue of April 23, 1889.

401,746—COMBINED BUTTON HOOK AND BRACELET. ALICE JOHNSTONE, Avondale, N. J. Filed January 14, 1889. Serial No. 296,253. (No model.) The inventor here has devised a bracelet consisting of a body portion terminating in enlargements which form part of the securing means for a detachable buttoner portion.

401,759—WATCHMAKER'S STAKING TOOL. JOHN C. ROCHELEAU, Worcester, Mass. Filed October 31, 1887. Serial No. 253,824. (No model.) The combination of the supporting stand adapted to be held in a vise and provided with rests for the work, and a barrel, screw-threaded sleeve and plug, provided with a central socket to receive a sliding plunger or tool, the said tool being flattened on its side, together with means by which the rotation of the tool is prevented.

401,815—STEM WINDING AND SETTING WATCH. CASPAR BOHNENSTIEL, Newport, Ky. Filed November 28, 1887. Serial No. 256,320½. (No model.) The combination of an outer plate having openings with rabbeted edges, and smaller openings, seconds wheel, cap with rabbeted edges, pinion, arbor, swiveled in cap and dial plate having four posts.

401,908—SEPARABLE BUTTON. GUSTAVUS A. SCHLECHTER, Reading, Pa. Filed July 16, 1888. Serial No. 280,142. (No model.) A button or badge consisting of two parts with engaging shanks, each of the parts having a pin projecting from its inner face parallel with the shank.

401,900—PLATING STOCK FOR JEWELRY. JOHN S. PALMER, Providence, R. I. Filed December 25, 1888. Serial No. 294,629. (No model.) This method of making plated metal shells or thimbles for use in the manufacture of jewelry, consists in forming suitable sized disks of the precious metal, in forming separate disks of nearly the same size of a baser metal, then soldering each of such precious disks to one of the baser ones, and then converting such plated disks into shells.

401,935—CHAIN. WILLIAM C. EDGE, Newark, N. J. Filed January 17, 1889. Serial No. 296,652. (No model.) This is an elastic self contracting tubular chain composed of elongated links that are arranged in spiral order, each link interlocking at each end with two other links, and each link being fastened to the links interlocking with it near one end, but free to slide on the links with which it interlocks near the other end.

402,011—FINGER RING. MOSES FREFD, New York, N. Y. Filed November 27, 1888. Serial No. 291,949. (No model.) In this ring there is a head provided with a recess, combined with a stone adapted to be received within it, a metallic plate upon the back of the stone having recesses or pockets formed between the latter and the stone, projections upon the ring head extending into certain of the recesses, a locking pin extending into another of the recesses, and a letter upon the front side of the stone provided with prongs extending through the stone and the metallic plate, by which both the letter and the plate are secured to the stone.

402,032—COMPENSATION WATCH BALANCE. AUGUSTUS F. PICKERT, Atlanta, Ga. Filed June 28, 1888. Serial No. 278,440½. (No model.) The combination with a balance having a sectional wheel-rim thickened at points opposite the end of the cross bar provided with screw holes, and of the segments and screws attaching the segments to said thickened portions of the sectional rim.

402,071—LOBE EAR RING. JAMES C. DORAN and HORACE A. HALL, Pawtucket, R. I. Filed March 22, 1888. Serial No. 268,158. (No model.) The inventors have here combined in an ear ring a threaded pin and the catch having the central aperture points with the opening between their ends, and the extended spring tongue passing over the opening to form a guard for the end of the pin passing between the points, its end extending between the points and having the screw-threaded aperture therein engaging the pin to retain the same in position.



[FROM OUR SPECIAL CORRESPONDENT.]

PHILADELPHIA, April 15, 1889.

About the busiest place in Philadelphia just now is the great factory of H. Muhr's Sons, corner of Broad and Race streets. Carpenters and machinists are at work here on all the floors occupied by the Muhrs, preparing for the reception of the plant of the Willemin Watch Case Company, which is about to be moved from Brooklyn, and for the resumption of the ring and locket business of Joseph Muhr, even now in operation. All branches of the business of H. Muhr's Sons will then be centralized under one roof, enormously increasing their facilities of manufacture. Solid gold cases, filled cases, rings, lockets, thimbles, etc., will all be numbered among the specialties of this enterprising firm. In their filled case department so brisk has the demand become that they have been obliged to fit up the basement for some of the heavier machinery, such as presses and rolls, the workmen being engaged in putting in place probably the largest pair of rolls ever put into a watch case factory when THE CIRCULAR's representative called. Jacob Muhr, of the firm, is at present in Europe buying precious stones for the coming season, when H. Muhr's Sons will bring out the largest and finest line of novelties in rings, lockets, thimbles and gold and filled cases that they have ever shown to the trade. The management of the several departments of manufacture devolves upon "Phiz" Muhr, who has proved himself quite equal to the task, and being born with mechanical tastes he revels in it, for a tidier and more ship-shape factory was never seen. From present indications it appears that in building so large a structure the firm showed great foresight. At this rate of growth another floor may be required shortly.

The large retail houses report quiet trade, with an occasional spurt of business when pleasant weather tempts the ladies out in numbers.

Business among the jobbers is still far from brisk, although a slight improvement over last month is noticeable. David F. Conover & Co. especially are reaping the benefit of their enterprise in constantly adding new specialties in materials, optical goods and jewelry to their unrivalled line of watches and cases. They no longer deal exclusively in watches, be it remembered.

Hollinshed Bros., 806 Chestnut street, are well satisfied with the progress they have made, as evidenced by their sales book. Chas. Hollinshed remarked jocosely to your representative, that "new men and liars" were doing all the business now, and that he feared if he gave a favorable statement of their condition they might be classed with one of these notables: but figures never lie, and in the short period of their existence Hollinshed Bros. have won a patronage that a much older house might well be proud of.

Gautschi & Son, importers of musical boxes, 1,030 Chestnut street, have fitted up their wholesale department, and can now supply the trade with musical boxes of all grades. Your representative was shown a fine box, playing ninety-six tunes, that was about to be shipped to Salt Lake City.

Quite a little ripple of excitement was caused recently by the appearance of M. Zineman, senior member of M. Zineman & Bro., the opticians, of South Ninth street, in a yellow-gear, black-bodied Stanhope gig, drawn by his mettlesome trotter, "Specs," elegantly caparisoned. Mr. Zineman takes a spin in the Park every pleasant afternoon as a relaxation from the cares of business. "Specs" is a pretty good stepper, but "Diamanta" is forging ahead of him, so Mr. Zineman says.

Atkinson Bros., wholesale agents for the Keystone watches,

announce that changes and improvements are being made at the factory at Lancaster that will largely increase the output of high grade watches, both three-quarter plate and dust-proof. These watches are becoming deservedly popular as reliable timekeepers.

The partnership of Bailey, Banks & Biddle expired by limitation last month, and a new limited partnership was formed by Joseph T. Bailey, Samuel Biddle, George W. Banks and Charles W. Bailey, general partners, and Clayton French, who contributed \$50,000 to the capital, special partner. The new partnership terminates February 28, 1894. The former style will be retained and the general nature of the business will be the same as heretofore. Westcott Bailey, the retiring member, has formed a limited partnership with E. W. Bailey, under the style of Westcott Bailey & Co. The firm will deal in precious stones, jewelry and objects d'art at 1,020 Chestnut street.

Hamilton & Diesinger, manufacturers of silverware, will move their factory in the near future from 621 Jayne street to 810 Sansom street, where they have purchased a site and will erect a factory.

The Retail Jewelers' Association, of Philadelphia, has secured permanent headquarters in a room near Tenth and Arch streets, where all the gatherings of the Society and their Executive Board will be held. The Association seems to be gaining strength and extending its influence beyond this city, as is evidenced by the organization of similar associations in other cities and towns. J. R. Hamer is the President, and in a conversation with THE CIRCULAR'S correspondent, he outlined a plan for a national organization which he thought might grow out of this. The following is a list of the officers: President, John R. Hamer; Vice-President, Wm. H. Long; Secretary, E. S. Radley; Treasurer, Wm. Haines; Cor. Secretary, Joseph W. Forsyth, Jr.; also fifteen directors. The object is mutual benefit. They hope by banding together to be able to purchase some goods to advantage and to engender a more kindly and friendly feeling. They also propose to adopt a scale of prices for watch and clock repairing, and to advance the interests of the trade in general.

The Jewelers' Security Alliance

President, DAVID C. DODD, JR.

First Vice-President, AUGUSTUS K. SLOAN.....Of Carter, Sloan & Co.

Second Vice-President, HENRY HAYES.....Of Wheeler, Parsons & Hayes.

Third Vice-President, DAVID UNTERMAYER.....Of Keller & Untermeyer.

Treasurer, W. C. KIMBALL.....Of Strange & Brother.

Secretary, GEO. H. HODENPYL.....Of Hodenpyl & Sons.

EXECUTIVE COMMITTEE.

J. B. BOWDEN, *Chairman*.....Of J. B. Bowden & Co.

C. G. ALFORD.....Of C. G. Alford & Co.

N. H. WHITE.....Of N. H. White.

CHAS. G. LEWIS.....Of Randel, Baremore & Billings.

F. KROEBER.....Of F. Kroeber Clock Co.

SILAS STUART.....Of Silas Stuart.

EXAMINING FINANCE COMMITTEE.

EDWARD SMITH.....Of Smith & Knapp.

A. JORALEMON.....Of A. Joralemon & Co.

For further information, Application Blanks for Membership, By-Laws, etc., Address
P. O. Box 3277. 170 Broadway, New York

At the regular monthly meeting of the Executive Committee, held at the Alliance office, on the 12th inst., there were present Vice-President A. K. Sloan, Chas. G. Lewis, Treasurer; Messrs. Kroeber and Stuart, and George H. Hodenpyl, Secretary.

The following were admitted: Chapman & Co., 227 High street, Holyoke, Mass.; R. C. Acton, 606 Ring st., Alexandria, Va.; Fred. H. Ingalls, 1007 Olive st., St. Louis, Mo.; John H. Frease, Napoleon, Henry Co., Ohio; Joseph Bevan, Main st., Winslow, N. C.; J. P. Steinmann, 107 Federal st., Allegheny, Pa.; Arthur Everitt, R. R. Ave., Albuquerque, New Mexico; E. E. Kipling, 151 Broad street, Providence, R. I.; The C. H. Green Jewelry Co., cor. 16th & Lawrence sts., Denver, Col.; J. F. Watts, 5th st., Freeport, Pa.; The New York Watch Co., 498 Main st., Buffalo, N. Y. Admitted in March: Otto W. Snyder, Lexington, Ky.; W. W. Schumann, Huron, Dakota.



[THE CIRCULAR is not responsible for the opinions or statements of contributors, but is willing to accord space to all who desire to write on subjects of interest to the jewelry trade. All communications must be accompanied by a responsible name as a guarantee of good faith. No attention will be paid to anonymous letters. Correspondence solicited.]

To the Associates of the Co-Operative Guilds.

140 West 23d street, New York.

April 23, 1889.

GENTLEMEN—You have kindly requested a brief summary of my views on the industrial art question, also a statement as to the scope and plan of art study pursued in the New York Institute for Artist-Artizans under my charge.

The former is a question of such reach backward into human history and forward into American life, that it demands the most earnest consideration of the people of these United States.

Beauty can and should be made both national and domestic in this country.

It is so evidently an attribute of the Creator, so clearly manifest as a life, property and principle in all His works, from the delicate shell or flower to the glorious heavens above us, that it needs no apologist. Its study cannot but refine, humanize and inspire.

As a spiritual essence incorporate in material form, beauty is a concomitant of every wholesome growth. The study of its divine principles of order, proportion, harmony, adaptation, etc., should be a profound part of every educational system. It is a power like gravity which "must count," as much now as ever, as much in the new world as in the old.

Now, nature and human nature being alike, mind and matter, soul and body, ideal and real, the true poet and the true business man, the true artist and the true artizan must find each other to be natural allies in relations of mutual benefit and support.

Sound art is helpful to every soul and to society, as is sound science or sound religion. So much for underlying principles and theory.

Practically the artist-artizan is prominently needed in the United States. A world republic founded essentially on democracy and industry, recognizing only the aristocracy of respectful, honest, intelligent labor. We should be the first of nations to discard feudal fallacies which placed art, liberty and religion among the exotics, the plaything of the dilettante, the monopoly of the few.

In insight into beauty we have fallen behind our fellow-men, not the ancients alone, or Italy now surviving by the legacy of its great art, but Germany, Belgium, France and England; these latter are pressing forward in the commercial race fully conscious of the benefits of art inspiration and education.

The Centennial Exhibition partly roused us from torpor, facilities for travel and transportation have done more and forced intellectual competition to our door. Popular taste and intelligence are rising like a tide throughout the world and rolling the industrial waves of the nineteenth century on our belated ship of state, which must rise with the tide or be overwhelmed like Canute.

Every one sees and feels the great change in the public taste, the keener appreciation of true beauty that has come to the American people, a sound business judgment can prove and count upon a still more rapid and thorough advance in public conscience and cultivation along the line of *applied Art* and the scientific study of beauty.

To provide for this rapid and ever increasing improvement in the taste and demands of our people is of the most vital importance to American industry. It can only be done by the most complete and thorough training of the Artist Artisans who shall furnish our indus-

C. K. COLBY,

CORBIN BUILDING (see page 43.)

11 John Street,

Room 35.

NEW YORK.

All kinds of Watch Cases,
All Manufactures of Watch Movements,
All Grades of Jewelry and
Diamonds.

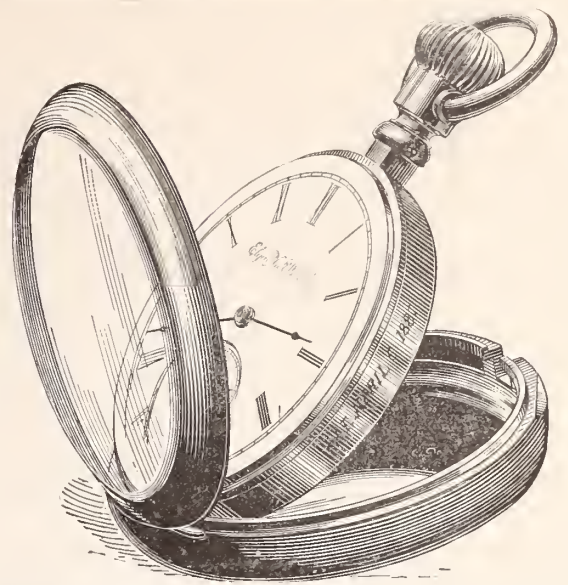

MANUFACTURER OF THE
Open Face One Joint Cup Case.

• AURANIA •

Height, 19 1/4 in. Dial, 5 in. Made in Black Walnut and Antique Oak, with Heavily Gilt Ornaments. List, \$9.75.

EIGHT DAY, STRIKING ON CATHEDRAL CONG.

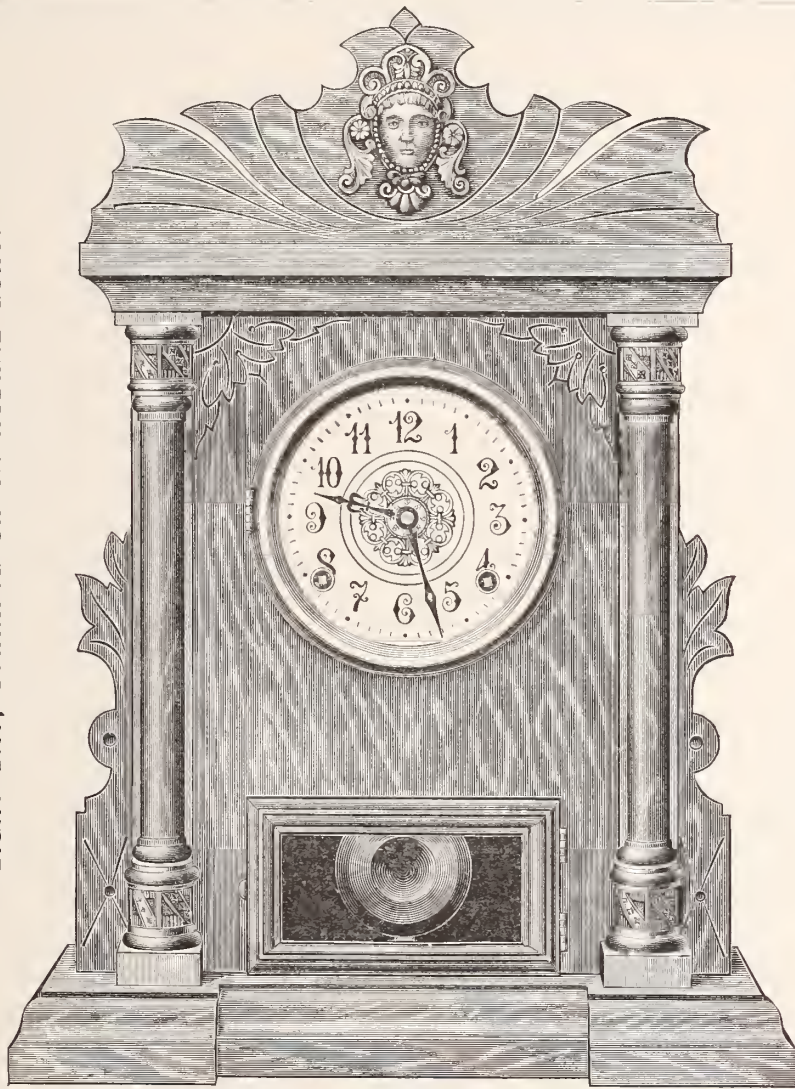

New Haven Clock Co.,

NEW HAVEN, CONN.

GENERAL SALESROOM:

29 Murray and 33 Warren Streets,

NEW YORK.

OFFICES AND SALESROOMS:

7 FRANKLIN STREET,

BOSTON.

315-321 WABASH AVE.,

CHICAGO.

The Alvin Manufacturing Company,

24 BOUDINOT ST., Newark, N. J.

We invite the attention of the Trade to the artistic line of

SOLID SILVER GOODS,

Now being produced by the Electro Deposit Process,

INCLUDING:

CLARET PITCHERS, DECANTERS, KIRAFFES,
PERFUME and TOILET BOTTLES, FLASKS.

And numerous other articles in Glass, crystal and colored. A full line of

TOILET ARTICLES,

ORIGINAL in design & FAULTLESS in execution,

EMBRACING:

HAND GLASSES, HAIR BRUSHES, CLOTH, HAT, MILITARY, Etc.
COMBS, MANICURE SETTS, Etc.

CANE AND UMBRELLA HANDLES, SILVER NOVELTIES, Etc.

PHOTOGRAPHS AND PRICES FURNISHED THE TRADE ON APPLICATION.

SEXTON BROS. & WASHBURN,

41 & 43 Maiden Lane, New York,

MANUFACTURERS OF

GOLD AND DIAMOND JEWELRY,

RINGS, BROOCHES, HAIR PINS,

Bonnet Pins, etc.

Roman Pearl Necklaces, 1, 2 and 3 Strand.

tries with designs and bring to the supervision of our manufacturers the truest artistic taste.

In speaking of the school in 23d st. in this city which I have established, I may say without breach of delicacy I feel, that a natural and early love for the beautiful in nature and in art has strengthened with study and toil. An inherited ancestral sympathy with the cause of humanity and my country, a university education, eighteen years' experience in art study and instruction, one-third of which was spent in Europe, have given me some fitness for the work of training Artist Artisans and the conduct of such a school.

My success in the direction of the best known art school in this city, which in four years grew from a handful of boys to a noble gathering of 400 men and women under my administration, is evidence of my conviction and purpose.

Should the Trade Guilds of the United States co-operate with the New York Institute for Artist Artisans as a body, as some of them have already decided to do, they will find the course of study at once national, organic, thorough and comprehensive, soundly artistic yet soundly practical, working by principles not recipes, by interpretation not mimicry, exceptionally instructive by comparison and suggestion.

Its aim shall be to produce the surest practical results—to give our industries the real thing they seek for in Art instruction.

Very truly yours,

Signed :

JNO. WARD STIMSON.

A PLEA FOR THE ARTIST-ARTISAN.

Baltimore, April 5, 1889.

To the Editor of the Jewelers' Circular :

Your letter interested me greatly. It opens up the whole question of industrial art education, which is one of the greatest importance to the manufacturing interests of our country; more than that, one which bears directly upon the elevation and welfare of all classes of the community.

The enclosed report, which was presented at the annual meeting of the U. S. Potters' Association, held last January in Washington, I am sure you will read. It gives a few only of the many reasons why art influence should be brought into close contact with every manufactory in the land producing articles suitable for the adornment of the person, or for household use and decoration.

I am greatly pleased to learn that through your well directed efforts the jewelers will furnish one thousand dollars to be expended during the next twelve months in art education, applied to the design and manufacture of jewelry and silverware. This is, I trust, the beginning of a movement that will bring all the trades mentioned to the hearty support of some art school, equipped for the thorough training of the artist-artisan, so that he may aid the progressive manufacturer in giving the art quality to his wares.

The trades have a common interest in industrial art education, for art, wherever applied, has a strong reflex influence. If the jeweler helps to create artistic taste by his product, that taste will demand artistic fabrics. If the furniture manufacturer gives his patrons thoroughly artistic work, the taste thus created and satisfied will demand artistic table wares of every class, and so on throughout the whole list of industries.

Our art industries, to secure the trained designers and artists they so much need, must focus their support upon some one school, for the laying of a good foundation, for artistic work takes the student for the first year, or two years, along the same broad lines of study, whether the end arrived at be decorative work in pottery, jewelry, wall paper, furniture, carpets, brass work, wrought iron or oil cloth—and a school to work up to the highest standard, with a corps of the best instructors, should have a class of at least two hundred stu-

dents, turning out annually one hundred or more, thoroughly qualified to do artistic work in that particular line of industry for which they have shown an aptitude and for which they have specially prepared.

Disguise it as we may, "art works for money, always has and always will;" therefore, to induce the student to spend time and money in preparing for industrial art work, he must first be shown that it is quite as dignified to create a really good piece of decorative work, that shall instruct and give pleasure to thousands, as it is to paint a poor portrait or a barely passable landscape. In addition to that he must feel quite certain that employment, which means pay, awaits him on his showing proficiency.

Probably no one industry could utilize a class of 100 annually, but all the trades combined and interested could easily do so, for with greater artistic value given to his wares the manufacturer would not only find increased demand, but increased profit, and the greater necessity for the artist-artisan.

A leading Parisian art dealer has just closed with one of our best American painters for all the pictures that leave his easel for some years to come. An American design for a dinner service, showing some freshness and thought, has been copied by two German porcelain factories and two leading English potteries. Let the industries of our nation seize the opportunity that now opens before them, and secure trained artists to give artistic character to their product, while they cease copying old world designs, good or bad, and buyers will soon forget to ask for imported wares, and say I want that article because it is *good* and it is *American*.

New York being the art center of the country, and having advantages such as no other American city has, would seem, for this reason and many others, to be the point of location for a National School of Design, such as the trades require. Some of the art schools now in operation there would probably be glad to do this work, and no doubt have classes prepared to take up the technique required by the different trades, and soon be in readiness for positions of usefulness in our factories.

You have spoken of the school at 140 West 43d street, of which Mr. J. W. Stimson is superintendent. I visited that school some months since, and was much impressed with the excellence of its methods for teaching the foundation principles of design, and the earnestness of all the instructors that I met. I have recently received a letter from an ex-president of the Art Students' League, and another from a person prominently connected with the Associated Artists; both speaking highly of Mr. Stimson's qualifications for such a work as the trade guilds need.

I suggest that you and others interested in this most important movement ask Mr. Stimson for his views upon the subject. I trust you will keep the ball rolling, for by so doing you will advance the highest interests of the trade your journal represents.

Very truly yours, D. F. HAYNES,

Chairman Com. on Design, U. S. Potters' Association.

1703 East Baltimore st., Baltimore, Md.

TO PREVENT FRAUDULENT FAILURES.

New York, April 6, 1889.

To the Editor of the Jewelers' Circular :

We have read with much interest your editorial on a "Plan to Avert Fraudulent Failures" in the April number.

We, in common with other manufacturers and jobbers, have suffered severely from the fraudulent failures of the past ten years, and in our judgment they are increasing to an alarming extent. But a very small percentage of failures nowadays are thoroughly honest. In very many instances the whole amount of an account is lost, simply by the debtor robbing us of our property under the form of law; while he nominally transfers his property to another name, he fraudulently remains the real owner and manager of the business, enjoys his ill-gotten gains without fear of punishment, and, in fact,

is as much a thief as the man who breaks into a store by burglary, only he is a more dangerous and contemptible thief.

While we concur with many of the suggestions in your article, we believe a plan of organization is already at our hands.

"The Jewelers' Protective Union" is organized principally for the purpose of punishing thieves, and it should include in that category the robbers who steal our property under pretense of purchasing them. We would suggest that the membership be divided into four or five different classes, according to the amount of their annual business, or of the number of accounts they have on their books, and charge each class what would be an equitable sum for initiation and annual dues (and assessments, if necessary). This would bring into the "Union" the smallest as well as the largest manufacturers and jobbers on a fair basis, for it would not be justice to charge one member, doing a business of \$100,000 a year, with perhaps but one or two failures to investigate in a year, the same price that you would the largest member, doing perhaps a business of two or three million dollars per annum, and necessarily having a larger percentage of failures for investigation. So much for the "plan of organization."

Then whenever a failure occurs, let the Executive Committee send out to the premises an expert accountant, to thoroughly investigate the business, back, say, two or three years if necessary; he to employ an expert appraiser to value the stock, the accountant to make a thorough examination of all so-called "preferred claims," such as "money borrowed from relatives," and satisfy himself as to the bona fideness of such claims, trace the loans, and, if necessary, investigate whether any actual money ever passed, and whether the alleged lenders ever had any money to lend, and if the money was ever put into the business, and what disposition was made of it, if the loan was paid back again—in other words, the accountant should be a first-class man, who would take no information for granted, but go to the roots for his information. Should this representative of the creditors find manifest evidence of fraud, he should be provided with the power of attorney to clap down on the thief at once, and the whole power and means of the Union should be brought to bear to punish him criminally, and no let-up or compromise should ever be allowed after criminal proceedings have been commenced.

Of course, every member should bind himself to accept no settlement except as authorized by the Executive Committee; it being understood that the Executive Committee should never recommend any settlement where the failure is tainted with fraud.

We think with a powerful and united organization of this kind, that in a very few years the fraudulent failures would be pretty well rooted out, as they would find it too costly a business to continue in. As it is now, they have grown bold because there is no united effort to fight them, whereas in the plan above proposed, the smallest member has the entire power of the association at his back to enforce punishment for rascality.

We might cite a great many instances that are familiar to almost every wholesaler in the trade, where the most barefaced robberies have been perpetrated by retail dealers, without any show whatsoever of opposition on the part of the mass, while a few creditors being thoroughly convinced of the fraud, have instituted proceedings on their own account, and the debtors found it very convenient to pay them their accounts in full rather than go through the exposure of a trial.

We commend this subject to the thoughtful consideration of your readers, and especially to the genial President of the "Jewelers, Protective Union" and his able colleagues.

Yours truly, BLANC & Co.

THE CAUSE OF INDUSTRIAL EDUCATION.

New York, April 13, 1889.

To the Editor of the Jewelers' Circular:

Your readers will, no doubt, be interested in the special attention which is being given to the subject of design in the Art Schools of

the Metropolitan Museum of Art, New York. Good classes in drawing and painting, both free hand and geometrical, have not hitherto been lacking in this and other schools of art in this city, and incidentally composition has not been neglected, but it has always been the desire of the trustees of the Museum School that its students should be able to apply their education to practical artistic industries of the higher order. The school has among its instructors such men as I. Q. A. Ward, R. Cleveland Coxe, Charles Vanderhoof and B. W. Clineduist, and there are classes in drawing, painting, architecture, sculpture, wood carving and metal work. To these has been added a special course in the general principles of design applicable to the industrial arts, which all are invited to attend. As the same laws of strength, beauty, form, color and taste obtain, whether applied to jewelry ornaments, pottery or furniture, a pupil well grounded in the broad principles of art can easily direct his talent in special fields. To complete the course an outline history of the various styles is given, with their relation to one another in all branches.

The school is about to be moved to the Museum building in the Park, where special rooms are being prepared for its occupancy to be in readiness for the October opening.

Yours truly, A. L. TUCKERMAN, *Manager.*

HOW TO PUT A CONCAVE LENS INTO THE FRAME,

Morrill, Kansas, April 11, 1889.

To the Editor of the Jewelers' Circular:

Will you please answer the following question through THE JEWELERS' CIRCULAR: Which is the right way to put a concave lens into the frame, with the concave surface toward the eye or away from it? I am proud to say I have advanced and learned considerable since I subscribed to THE CIRCULAR. I could not do without it, and would not as long as I could raise enough money to pay for it. It is worth many times its cost.

W. H. HALDEMAN.

[Set concave side toward the eye.—ED.]

A DEMAGNETIZER FOR WATCHES.

Galveston, Texas, March 16, 1889.

To the Editor of the Jewelers' Circular:

In the January number of THE CIRCULAR you mention, in an article about magnetized watches, a demagnetizer in which to place a watch. There being so many inventions for this purpose, and some being of no value whatsoever, I would be obliged to you for some information in regard to a good and effective demagnetizer.

A. J. ROEMPKE.

[The Graves demagnetizer, patented by John Graves and manufactured by the Mermod-Jaccard Jewelry Co., St. Louis, Mo., is in use by several houses, and is generally thought to be a very reliable, though not perfect, apparatus. Its price is \$35.—ED.]

UNSOLICITED TESTIMONIALS.

Madison, Me., March 27, 1889.

To the Editor of the Jewelers' Circular:

You will find enclosed \$2, for which please continue my number of THE CIRCULAR another year. It is of too much benefit to me to get along without it.

T. F. MANTER.

Boston, Mass., April 1, 1889.

To the Editor of the Jewelers' Circular:

You will find enclosed my subscription to THE CIRCULAR for 1889. I trust that this year will be the most prosperous one to you, and that your circulation may largely increase is the wish of

Yours truly, GEO. S. MELVILLE.



METHUSELAH & CO.,

MANUFACTURERS OF

Filled Gold Watch Cases,

No. 100 Cheapside,

OKLAHOMA, I. T.



Our Cases are better than an endowment policy. We detail special police to protect them after they leave our hands. We warrant them to outwear the wearer, and insure them against accident in his possession. Our cases are life-preservers in emergency; amulets insuring success in love; they are proof against the evil-eye and the incantations of witches and sorcerers, and any one who will take the contract of wearing one out is certain to live to a green old age.

The sad History of Methuselah & Co, Manufacturers of Filled Gold Watch Cases.

- Scene I.—Methuselah & Co. take a hand in the game of guarantee poker. They add a cypher and raise the ante. Scene—The En-grave-ing Room.
- Scene II.—Methuselah's conscience is troubled.
- Scene III.—And the Fakir Baiteth his Hook therewith.
- Scene IV.—Like the wonderful one-hoss shay, It wore a hundred years to the day, Then Father Time discontinued it and assayed it.
- Scene V.—Methuselah is gathered to his fathers, His grave "whereon the 'wild time' grows," cannot be kept green.
- Scene VI.—His 'case' is called for judgment.

WE CONTINUE THE MANUFACTURE OF THE

Willemin
Case
Company's

JUSTLY CELEBRATED

18-kt., 14-kt., 10-kt.,
Solid Gold Cases.

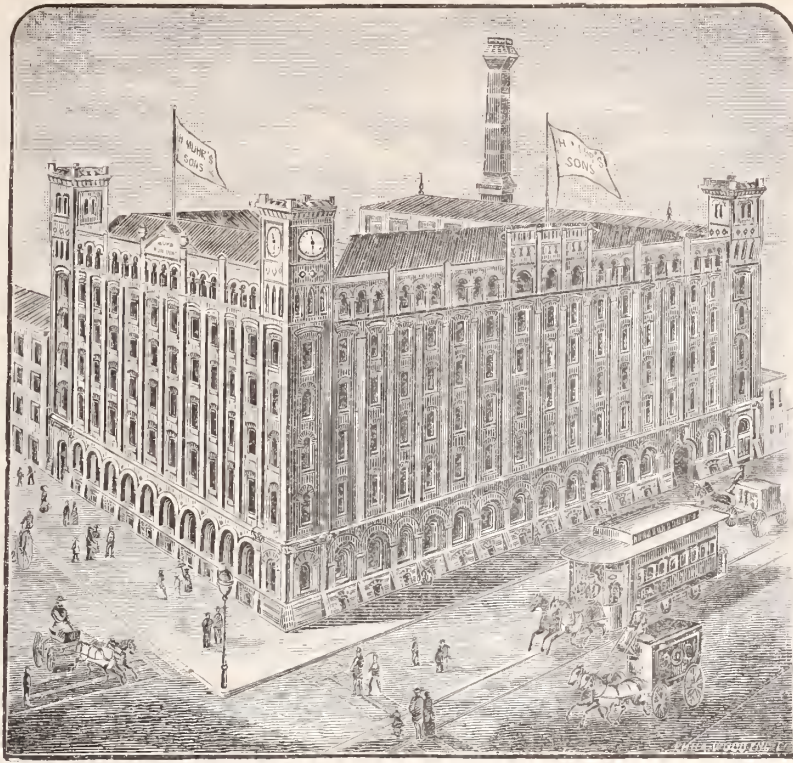

—OUR—
"CROWN,"
"EXCELSIOR,"
"LION,"
Gold Filled Cases

Are and will be only
guaranteed in keeping
with their quality and
price.

H. MUHR'S SONS,

PHILADELPHIA. - - 629 & 631 Chestnut Street.
NEW YORK, - - - 20 John Street (after May 1).
CHICAGO, - - - - - 139 State Street.
ANTWERP, - - - - - 28 Rue Simon.

DIAMONDS and all other PRECIOUS STONES.

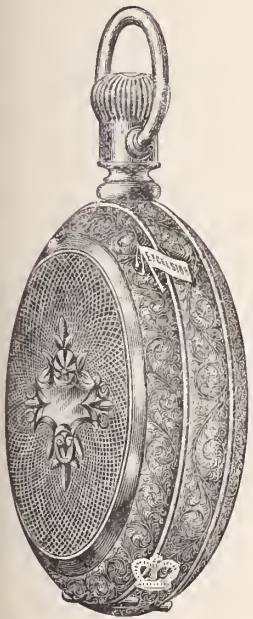

Rings,
Thimbles,
Locketts.



MANY
New Novelties
FOR THE
COMING SEASON.

Competition for the Rating of Watches at the Geneva Observatory, in 1888.

[*Journal Suisse Horlogerie.*]



THE last meeting of the Class of Industry of the Society of Arts, Colonel Gautier, Director of the Observatory of Geneva, made a verbal report on the competitive examination of watches, deposited in 1888. In our next issue we shall give his official report, which, owing to his absence for several weeks, will be delayed in publication; meanwhile, our readers will find appended the table of chronometers which have received premiums. We would remind our readers at this instance, that only those timepieces made in the Canton of Geneva, have the right of claiming the premiums allowed by the Class [of Industry]. In this table, we have not given the number of points resulting from the different tests, as they are of a relative interest only, and, if desired, may be easily calculated; their places are occupied by certain details of construction, which are more worthy of being known, so as to better appreciate the results obtained.

The following is the table of the best results obtained by houses having sent in at least five chronometers:

Letters Designating the firm.	Number of Watches.	Number of Inscription at the Observatory	Number of Points obtained by the Watch's	Average for the five Watches.	Name of the House.
A	31	{ 413 152 169 412	{ 215,3 210,7 196,1 191,0 187,5	200,12	Patek, Philippe & Co.
G	5	{ 246 438 166 75 167	{ 208,9 205,0 187,6 153,6 134,2	177,86	A. Pavid.
F	18	{ 81 428 442 384 385	{ 211,3 181,9 167,0 164,6 163,4	177,64	Geneva Non Magnetic Watch Co.
D	12	{ 361 135 191 153 92	{ 194,4 176,9 176,1 168,7 156,8	174,58	H.-R. Ekegrèn.
O	5	{ 215 452 170 255 450	{ 191,2 183,0 177,6 175,0 115,1	168,35	F. Piguet & Bachmann.
I	13	{ 422 417 430 97 416	{ 179,8 166,0 161,1 158,4 156,1	164,28	Zentler Brothers.

Extract from the Tables contained in the Report of Colonel Gautier, Director of the Observatory, Geneva, on the Rate of Watches for 1888.

Number of Watch at the Observatory.	No. of the Watch.	TEST.			Total of Points.	Name of Manufacturer.	Name of Adjuster.	Escapement.	Hairspring.	Other details of Construction.	Awards.
		I. Mean Daily Variation.	II. Mean Variation for whole Period.	III. Error of Compensation.							
413	72586	± 0,26	± 0,95	± 0,024	215,3	Patek, Philippe & Co.	W. Beaufrère.	Anchor	Breguet (curved)		1st Prize.
81	6206	0,26	0,95	0,032	211,3	Geneva Non Magnetic Watch Co.	C.-A. Paillard.	"	Curved palladium.	Paillard's Bal.	2d Prize.
1	65580	0,33	0,57	0,045	210,7	Patek, Philippe & Co.	Al. Favre.	"	Cylindrical.		"
246	1692	0,34	0,77	0,030	208,9	A. Pavid.	A. Pavid.	"	Breguet (curved)		3d Prize.
438	2046	0,17	1,27	0,043	205,0	"	"	"	(steel)		"
78	1	0,34	1,19	0,014	200,1	A. Hillgren.	A. Hillgrèn.	"	Hillgrèn.	Hillgren's Bal.	Hon. Men.
213	1889	0,28	1,36	0,018	199,3	Adrien Goy.	Adrien Goy.	"	Palladium-Iridium		"
152	69641	0,34	1,19	0,022	196,1	Patek, Philippe & Co.	J. Romieux.	"	Breguet (curved)		"
361	18690	0,32	0,91	0,053	194,4	H.-R. Ekegrèn.	H. R. Ekegrèn.	"	"		"
150	47736	0,31	0,89	0,063	192,6	J.-J. Badollet & Co.	J. Golay fils.	"	"		"
215	4885	0,44	0,94	0,025	191,2	F. Piguet & Bachmann.	A. Favre-Rochat	"	Curved palladium.		"
169	77115	0,29	1,02	0,059	191,0	Patek, Philippe & Co.	W. Beaufrère.	"	Breguet (curved)		"
2	2397	0,46	1,26	0,075	190,8	Marius Lecoultré.	A. Montchal.	An. st. l.	Cylindrical.		"
30	48084	0,17	1,72	0,040	188,5	J.-J. Badollet & Co.	J. Golay fils.	Anchor	Breguet (curved)		"
166	22878	0,19	1,19	0,079	187,6	A. Pavid.	A. Pavid.	"	"		"
412	72593	0,34	1,08	0,148	187,5	Patek, Philippe & Co.	J. Romieux.	"	"		"
389	72594	0,35	0,89	0,063	186,2	"	"	"	"		"
370	76756	0,26	1,02	0,079	185,0	C. Haas Thellaëche & Co.	Ch. Haas.	"	"		"
452	9763	0,43	0,73	0,061	183,0	F. Piguet & Bachmann.	A. Favre-Rochat	"	Curved palladium.		"
192	55017	0,25	1,14	0,077	182,6	Patek, Philippe & Co.	J. Romieux.	"	Breguet (curved)		"
428	6761	0,22	2,02	0,016	181,9	Geneva Non Magnetic Watch Co.	A. Hillgrèn.	"	Palladium Paillard	Paillard's Bal.	"
316	3218	0,35	1,38	0,036	180,1	Marius Lecoultré.	M. Lecoultré.	"	Breguet.		"
422	13029	0,17	1,20	0,099	179,8	Zentler Brothers.	W. Beaufrère.	"	Breguet (curved)		Mention.
257	77426	0,32	0,94	0,081	179,2	Patek, Philippe & Co.	"	"	"		"
170	9616	0,31	1,74	0,023	177,6	F. Piguet & Bachmann	A. Favre-Rochat	"	Curved palladium.	Quarter repeat'	"
394	71535	0,23	1,03	0,102	177,1	Patek, Philippe & Co.	A. Hoffer.	"	Breguet.		"
135	18796	0,18	1,54	0,051	176,9	H.-R. Ekegrèn.	A. Hillgrèn.	"	Breguet (curved)		"
191	18822	0,44	0,93	0,056	176,1	"	"	"	"	Hillgrèn's Bal.	"
255	5868	0,22	1,53	0,069	175,0	F. Piguet & Bachmann.	A. Favre-Rochat	"	Cylind. palladium		"
335	76783	0,18	1,57	0,078	174,2	Patek, Philippe & Co.	W. Beaufrère.	"	<i>Mangor.</i>	Woltine's Bal.	"
62	77424	0,33	1,28	0,071	169,3	"	A. Hoffer.	"	Breguet (curved)		"
153	18315	0,23	1,54	0,078	168,7	H.-R. Ekegrèn.	Al. Favre.	"	Cylind. palladium		"
383	76746	0,23	1,49	0,083	168,2	C. Haas Thellaëche & Co.	Ch. Haas.	"	Breguet (curved)		"
415	76782	0,43	1,44	0,034	168,1	Patek, Philippe & Co.	W. Beaufrère.	"	<i>Mangor.</i>	Woltine's Bal.	"
442	7395	0,34	1,78	0,033	167,0	Geneva Non Magnetic Watch Co.	C.-A. Paillard.	"	Curved palladium.	Paillard's Bal.	"
353	77113	0,19	1,13	0,127	166,0	Patek, Philippe & Co.	W. Beaufrère.	"	Breguet (curved)		"
417	13032	0,39	1,15	0,072	166,0	Zentler Brothers.	"	"	"		"
384	55832	0,40	1,14	0,073	164,6	Geneva Non Magnetic Watch Co.	Al. Favre.	"	Palladium.	Paillard's Bal.	"
385	55804	0,32	1,86	0,039	163,4	"	"	"	"		"
386	6762	0,32	1,19	0,095	162,2	"	"	"	"		"
371	77111	0,20	1,48	0,105	161,6	Patek, Philippe & Co.	W. Beaufrère.	"	Breguet (curved)		"
430	13033	0,33	1,46	0,073	161,1	Zentler Brothers.	"	"	"		"
426	55812	0,28	1,28	0,101	161,0	Geneva Non Magnetic Watch Co.	Al. Favre.	"	Palladium.	Paillard's Bal.	"



[FROM OUR SPECIAL CORRESPONDENT.]

EFFECTS OF THE COPPER SQUEEZE.—THE ANNUAL LENTEN LULL.

BOSTON, April 10, 1889.

Weather is good but business is dull on account of the Lenten season. The main trouble seems to be the fit of economy that has overtaken the moneyed part of the community by reason of the steady decline in railroad values. Almost everyone who owned Atchison stock is feeling poor since its shrinkage of over 40 per cent., while the general drop has seriously affected C. B. & Q., and the forlorn condition of Calumet & Hecla and the Boston & Montana Copper Co., in which our people are largely interested, fairly represents the awkward financial situation. And so luxuries are being given the go-by although by dint of persistent advertising of Easter season specialties some of the local jewelers have, in a measure, overcome the conservative tendency of trade. Others report light sales and a backward outlook.

Tuesday morning, April 2, a fire broke out in the building corner of State and Washington streets, causing damage to several of the occupants, among them A. W. Mitchell, to the extent of about \$1,500. Insurance \$3,600.

Meyer Frank has disposed of a portion of his stock at auction, and removed to new quarters at No. 589 Washington street. The building in which his old store was located, No. 83 Hanover street, is to be torn down.

George E. Fletcher, Haverhill, Mass., has failed, with liabilities of \$600, and no assets except stock, fixtures, etc., which are fully covered by a mortgage. His wife, Rosa A. Fletcher, will continue the business.

Inspector Leggett, last Saturday morning, arrested Alfred H. Wetherbee for obtaining jewelry from the H. A. Prentice Company, last December, on the installment plan, and afterward pawning it with A. Aronson, Jr., No. 872 Washington street.

The recent statement of the American Waltham Watch Company to their stockholders shows that great corporation to be in a condition of wonderful prosperity. There is about \$2,000,000 surplus, \$1,000,000 of which will be distributed among the stockholders in the form of a stock dividend, so that they will get the new stock at par, and the capital is increased thereby to \$3,000,000.

Josiah Pratt died at his home in Prattville, Chelsea, last Thursday, at the advanced age of eighty-four. Many years ago Mr. Pratt originated the manufactured coffin plates. He was the last survivor of the venerable Pratt families of Prattville.

Alanson Bigelow, of the firm of Bigelow, Kennard & Co., has purchased a fine estate at Chestnut Hill, which he will make his future home.

The entire stock of Louis Bonnie, at No. 206 Hanover street, was disposed of at auction, it being Mr. Bonnie's announced intention to retire permanently from business. He claims to have been established thirty-five years, and values his stock at \$15,000.

The New Haven Clock Company, which has occupied quarters at No. 7 Franklin street for four years past, is about to remove to Summer street. They will have one-half of the store numbered 52 and 54, now occupied by the Hall Rubber Company.

Thaxter & Brother, opticians, have removed from the store No. 416 Washington street, occupied by them for so many years, to the store No. 9 Bromfield street.

Ex-Mayor W. B. Fowle, of Newton, is one of the candidates for the collectorship. He will be remembered in connection with the

defunct Auburndale Watch Company, in which he sank the greater part of his property. Mr. Fowle was the third Mayor of Newton, is an expert accountant, and has good backing among some of the best of our merchants.

Mrs. Samuel Little, wife of the President of the E. Howard Watch and Clock Company, and Arthur M. Little, her son, have taken passage for Europe by the *Cephalonia*, which sails June 23.

Henry T. Spear & Son have been making decided improvements at their well-known store on Washington street, having had a new floor laid, substantial additions made to their wall and show cases, and facilitated the mode of ingress and egress. They are doing a rushing business.

William Mullen, jeweler, has removed from No. 30 West street to Room 8½ No. 149A Tremont street, for better facilities.

T. F. Washburn, manager of the American Supply Company, and his wife, celebrated the fifth anniversary of their marriage at their residence, 178 Shurtleff street, Chelsea, March 28. About 200 were present, and Mr. and Mrs. Washburn were the recipients of many valuable gifts.

It has been decided by the Merchants' Week Association that the two weeks of May 6 and 7 to 20 and 21, be set apart as an occasion for the visit to this city of the retail merchants of New England, and arrangements have been made with railroads for half fares for points beyond fifty miles from Boston during this period.

Frank B. Howland has started in the retail jewelry business at No. 5 Waverly Block, Charlestown, Mass. He was formerly with Orson S. Philbrick, a Charlestown jeweler, but is a native of Lowell, Mass. He and his father occupy the store together, the senior being engaged in the piano business.

Thomas F. Butler, who was connected with the Meriden Britannia Company, of Meriden, Conn., and whose death occurred at the residence of his brother, William S. Butler, of the firm of W. & S. Butler & Co., department stores, Boston, was well known in this city.

T. L. Bottomly, of this city, who is an enthusiastic collector of the antique, was recently the recipient of a curious knife, supposed to have been worn by some ancient Norseman, which was obtained by Charles Matthews during his recent travels in Norway and Sweden.

The report that the Shreve, Crump & Low Company had taken possession of the southern corner of West and Tremont streets, and were seen to move there from their present quarters, is pronounced incorrect by Mr. Shreve. The company has nearly two years longer to remain where it is now located, on the corner of Washington and Summer streets, before its lease expires. It will come into possession next June of the store on the opposite corner, belonging to the N. J. Bradlee estate, and in all probability a new building will be erected there. If nothing miscarries the company will have three or more floors, which will enable it to divide its business into departments, an arrangement which is much needed, as the company's gas fixture branch of its business is located on Columbus avenue, which is a long way from the store. Although nothing definite has as yet been decided upon and no plans formulated, the new building will probably have a frontage of about thirty feet and a depth of 125 feet.

An irate set of men were the pawnbrokers last week, the board of police having issued an order which compels them to make a written return every day to the police, which is later sent to the inspector's office at Headquarters, of all business transacted by them, and giving the names of their customers and their description. There are about 60 or 70 brokers in the city, paying a license fee of \$20 each for the privilege of doing business, and they consider the order unfair, not only to themselves, but particularly to their patrons. Some were so provoked over the order that they returned their licenses and propose conducting the same business as collateral loan companies. Large

ORGANIZED 1851.

CHATHAM NATIONAL BANK,

Corbin Building.

OCCUPIED BUILDING ON THIS SAME CORNER, 1860.

COMPARISON, 1860 AND 1889.

	CAPITAL AND SURPLUS.	DEPOSITS.
1860	\$466,000	\$612,000
1889	1,000,000	6,000,000

STATEMENT, APRIL 1st, 1889.

<i>Resources.</i>		
LOANS AND DISCOUNTS,		\$5,222,092
U. S. 4½ BONDS (PAR VALUE),		50,000
DUE FROM BANKS AND BANKERS,		400,924.50
CASH,		1,657,838.13
		<u>\$7,330,854.63</u>
<i>Liabilities.</i>		
CAPITAL STOCK,		\$450,000
SURPLUS AND UNDIVIDED PROFITS,		576,799.62
CIRCULATION,		45,000
DEPOSITS, INDIVIDUAL,		4,989,168.94
" BANKS,		1,269,886.07
		<u>\$7,330,854.63</u>

DIRECTORS:

GEORGE M. HARD,	President,
	192 Broadway.
CHARLES HAUSELT,	Leather,
	29 Spruce Street,
THOMAS W. ADAMS, T. W. Adams & Co. (Jewelry),	
	14 John Street.
HENRY M. ANTHONY,	Gen'l Com. Merchant,
	100 & 102 Reade Street.
ALFRED F. CROSS,	Cross & Beguelin (Watches),
	21 Maiden Lane.
DAN. B. SMITH,	Com. and Forwarding Merchant,
	74 Warren Street.
HENRY RANDEL,	Randel, Baremore & Billings, (Diamonds),
	29 Maiden Lane.
JOHN H. WASHBURN,	Vice-Pres't Home Ins. Co.,
	119 Broadway.
P. H. KELLY,	P. H. Kelly Mercantile Co.,
	St. Paul, Minn.
SAM'L WILDE,	Sam'l Wilde's Sons (Coffee),
	11 Dutch Street.
HENRY P. DOREMUS,	Cashier,
	192 Broadway.
SANDFORD H. STEELE, Briesen & Steele (Attorney),	
	229 Broadway.
GEN'L HENRY W. SLOCUM,	465 Clinton Ave.,
	Brooklyn.

GEO. M. HARD, President.

H. P. DOREMUS, Cashier.

W. H. STRAWN, Assistant Cashier.

CORBIN BUILDING,

BROADWAY AND JOHN STREET, NEW YORK.



◆ DIRECTORY. ◆

First Floor.

CHATHAM NATIONAL BANK.

Second Floor.

- 1 2—J. B. BOWDEN & Co.
- 3—UNGER BROTHERS.
- 5—ATLANTIC WATCH CASE Co.
- 5—CHAS. KELLER & Co.
- 6, 7—KELLER & UNTERMAYER.
- 8—HENRY C. HASKELL.
- 8—IRVING L. RUSSELL.

Fifth Floor.

- 25, 26, 27—ELGIN NATIONAL WATCH Co.
- 28, 29, 30—BROOKLYN WATCH CASE Co.

Sixth Floor.

- 33—ILLINOIS WATCH Co.
- 34—FIDELITY WATCH CASE Co.
- 35—C. K. COLBY.
- 37—CHARLES GLATZ.
- 38—WM. H. BALL & Co.
- 39—WM. C. GREENE & Co.
- 40—HAMILTON & HAMILTON, JR.

Eighth Floor.

- 51, 52—CELLULOID ENAMEL Co.

Front Tower.

J. H. NOYES, Sec'y of Nat. Assn.

Store, 13 John St.

NEW YORK STANDARD WATCH Co.

printed sheets were given the pawnbrokers which are to be filled out, giving a description of the article pledged and of the person pawning it, with the name of the latter. These reports have to be returned to the police properly made out by 10 o'clock every morning, or else a complaint is lodged against them which may result in their losing their licenses. This plan is in vogue in Chicago, St. Louis and other cities, and the board of police got the idea during its western trip.

Edward D. Holmes was arrested last Monday, March 25, on the charge of conveying a horse mortgaged to Morrill Brothers & Co., August 11, 1887, and valued at \$200.

Little Corinne, Boston's charming little comedienne, was presented on the night of March 4, at the Academy of Music, Chicago, with what is believed to be the largest Canary diamond ever brought to this country. It was the gift of Manager H. R. Jacobs, weighs 42½ karats and is of great brilliancy. It is said to have been purchased from a royal family of Paris at a cost of \$15,000, and the import duty was \$480. Mr. Jacobs has been negotiating for this gem for nearly two years, and Little Corinne now possesses two of the most valuable diamonds in this country.

C. Sumner, formerly in the jewelry business at Marblehead, Mass., and who was one of the sufferers by the late fire there, has removed his stock to Claremont, N. H. Mr. Sumner has also given up his branch at Waltham, Mass., which was in charge of Charles Salie, and the latter has started in business on his own account at No. 1,175 Washington street, Boston.

Several well-known business men of New Bedford have taken the initial steps toward the formation of a company there for the manufacture of watches under patents which embrace reliability, and, at the same time, permit the watches to be sold at a low price. The scheme is welcomed, as the establishment will employ a large number of people of a desirable class. Charles R. Price has been made a committee on subscription, and stock has largely been taken to some extent, although the idea is yet in its infancy.

There have been rumors circulated regarding the future movements of the firm of Palmer, Bachelder & Co., but the latter announce that they have determined to completely liquidate their business.

Icelus Fay, jeweler, Worcester, Mass., is endeavoring to compromise with his creditors at fifty-five cents on the dollar. The liabilities are slightly more than \$2,000 and the assets about \$1,250.

The American Waltham Watch Company is well represented among the fire laddies, and at the recent elections in the fire department, Freeman C. Hodgson was chosen as clerk, a position he has held for many years; Atwood J. Jackson was re-elected foreman of steamer 1, which is his tenth term; William D. Newland was elected assistant foreman. These are all gentlemen connected with the watch industry.

There promises to be considerable litigation before the affairs of Charles Crowther, insolvent jeweler, of Malden, Mass., are adjusted. A notice was inserted in the daily papers announcing that the stock of jewelry, etc., would be sold at auction, but the sale did not take place. It appears that some of the creditors have refused to recognize Charles Crowther as the proprietor of the business or the owner of the property referred to, as they claim to have direct dealings with J. W. Crowther, a son, and claim that he is the real owner. They have, therefore, attached the stock of jewelry, etc., removed the same to Whitman's stable in Newton, Mass., and it was there sold at Sheriff's sale.

William T. Murphy, jeweler, No. 8 Washington street, is endeavoring to dispose of his business there.

There died in Lowell, Mass., a few days ago an old watch and clock repairer and dealer named George Thatcher, who had been in business in Lowell for more than forty years.

The liabilities of S. W. Bailey, jeweler, Boston, are about \$4,200, and the assets \$3,500. The stock is said to have been taken at cost prices.

E. E. Burdon & Co., who recently suspended, are as reticent as

ever in regard to their affairs. They will give no statement as to assets and liabilities, saying that they have been advised to take this course by their creditors. Their indebtedness is, in the main, to parties outside of this city, but it is the impression, from the remarks let drop, that they have already got a settlement, whatever it is, from a majority of the creditors.

LEON.



[FROM OUR SPECIAL CORRESPONDENT.]

ATTLEBORO, April 18, 1889.

The dulness in the trade among the manufacturers still continues. Orders come in very slowly in most cases and some of the best shops are only running three days in the week.

ATTLEBORO.

When business is dull it is difficult to tell anything of interest to the trade. Wherever I go the same old story greets my ears, "no business." The men are getting dissatisfied and some are leaving town. I believe there is going to be a revolution in the business as it is conducted here before long. As every one knows, "jewelry" is what has made Attleboro, it is Attleboro, and because of this industry, to this town have flocked young and old from all parts of the country, who know anything about the business. To these have been added 80 per cent. of the young of both sexes, who claim Attleboro as their native place. These have been brought up with the one end in view of eventually becoming "jewelers." The result of such a training has been, that nearly all of the people of the town know nothing of anything else, and remain here perforce whether there is any business or not.

H. M. Daggett, Jr., of the firm of Dagget & Clap, is very much interested in a proposed electric railroad between this town and Plainville.

J. J. Horton, of the firm of Short, Nerney & Co., returned this week from an extended trip through the south, where he has been traveling for his health.

C. L. Watson, of the firm of Watson, Newell & Co., is in California. He is expected home in a few days.

NORTH ATTLEBORO.

The jewelry business of this town compares very well with that of Attleboro. The conditions which exist in the latter town are just as true here. The business is dull everywhere, and I have been unable to pick up any interesting items for the trade. Every manufacturer says there is nothing new. He is merely lying on his oars waiting.

A new establishment for the manufacture of silver goods, composed of W. H. Franklin and others, is spoken of to be shortly located here.

Tappan, Berry & Co. will shortly move into the Bates Building, occupying the former quarters of Watson, Newell & Co.

Owing to a typographical error it was stated in my last letter that the F. G. Whiting Building was sold at auction. It should have read the F. G. Whitney Building, not to be confounded with the Whiting factory, occupied by F. M. Whiting & Co. and others.

MENDON.

Among the hereditary jewels belonging to the Duke of Cumberland are Queen Charlotte's pearls, valued at £750,000, about which, for twenty years, Queen Victoria and the Hanoverian King quarrelled with magisterial dignity. The Queen maintained that they belonged to England. The King insisted, on the other hand, that they should have been sent to Hanover on the death of William IV., 1837. The other jewels belonging to the Duke are valued at \$2,000,000. His gold and silver plate weighs twelve tons.

Labor-Saving Aids.

The Latest Device in Letter Engraving—A Simple but very Ingenious Instrument.

BY GEO. F. WHELFLEY.



SOME YEARS ago considerable attention was directed to machines to facilitate letter engraving, which it was hoped would make the cost of such work very low, while it could be done quickly and with little exertion. Several machines were evolved in succession, some of them capable of doing very fair work, but most of them were too troublesome and required more ingenuity to handle them than would suffice to make a skilful engraver, by hand, of the operator. Especially was this the case with the larger and more complicated machines. They had too many parts to adjust and keep in order; they were too unwieldy and cumbersome for the table or work bench, and therefore required a separate stand or table for their own use; and besides all, they were too costly. People do not relish the idea of investing a large amount of money in an instrument which they are not certain they can utilize and reimburse themselves from. What the busy jeweler or amateur requires is some engraving



instrument that will always be ready to work at a moment's notice; that requires no delicate adjustment or preparatory arrangement to consume valuable time and cause such trouble. He wants something that will work just as promptly as the graver in his own hand, but much more easily and swiftly. The plainer and simpler the instrument the better, so long as it does good and quick work.

The instrument in the line of engraving machines that comes

nearest to the desired qualities of simplicity, capacity and cheapness, is one which I have recently inspected and which is probably new to the great majority of the readers of THE JEWELERS' CIRCULAR. It may interest them to give a brief description of it and how it works.

The instrument can be fastened to any ordinary bench or table by a simple arrangement, and is operated by the foot, somewhat after the manner of the sewing machine, but much less exertion is required to drive it. A treadle, a driving wheel, a disc which drives a piston rod on the principle of the eccentric, a stationary cylinder, a rubber tubing, connecting the stationary cylinder with a movable one which is held in the hand and to which is attached a graver, constitute the features of the instrument which we are considering.

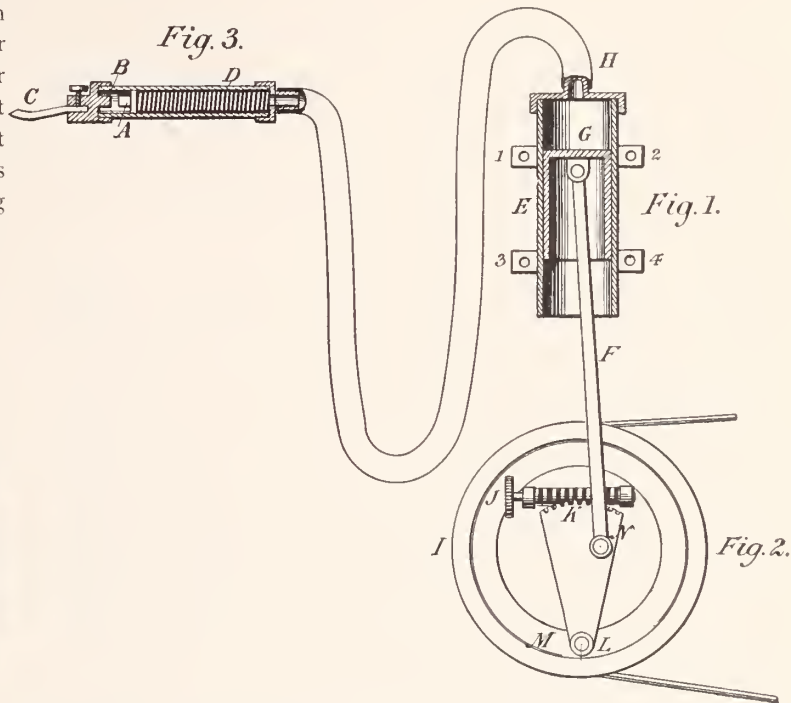

As I have intimated, air is the agent which runs this simple but ingenious contrivance. Every tread of the foot produces a revolution of the driving wheel, which causes, in turn, several revolutions of the disc. To this disc is pinned the piston of the stationary cylinder, the distance from the center of the disc—and consequently the length of the stroke—being regulated by an adjustable screw. Each revolution of the disc is followed by a forward and backward movement of the piston in the first cylinder.

Now, when the latter piston is driven forward, it pushes the air from the stationary (or first) cylinder through the rubber tubing into the smaller movable (or second) cylinder, and drives out the piston of the latter. A graver is fastened to this piston, which is driven forward with each stroke of the first piston or each turn of the disc eccentric. This is the whole secret of the mechanism.

In working, the graver is acted upon by the air driven from the first cylinder into the second through the medium of the rubber tubing, and works with great rapidity. The operator holds the second cylinder in his hand, with the point of the graver held close down to the work. All he need do is to guide the graver so as to make a clean and nice cut, light or heavy, as is called for.

No labor in making the usual digs and cuts in engraving is required. The graver does all that if properly held. Of course, much depends on the manner of holding it. A novice cannot do it well without some experience. Neither can he cut with a graver by hand without some skill and a good deal of practice. If a person learn how to guide the graver, which is a matter within the capacity of all, his work will be reduced to a minimum in difficulty, and the amount of performance will be vastly increased.

Then as to the quality of the work. A person might infer from the above imperfect description that it would necessarily be ragged

and uneven. Such a conclusion would be erroneous. I have seldom seen nicer work done by hand, even in the case of professionals, than I have inspected as the product of this instrument. I have seen specimens of script, with flourishes, ornamental letters, monograms, scroll work, flowers and arabesques done by it, and they were all very clearly, correctly and creditably executed. Although the engraver was a jeweler and able to devote only a small portion of his time to engraving, most people would judge the work to have been done by the hand of an expert.

On account of the few parts involved in this engraving instrument, and these of a simple and inexpensive kind, it will be offered for sale at a very low figure, and in this respect will be in marked contrast to the bulk of the engraving machines hitherto placed on the market.

Its adaptability to any kind of work which ordinarily falls in the line of the jeweler or undertaker, or which the amateur would be likely to want done, renders it peculiarly applicable by those classes of persons. A job which might be wanted in haste could be done by this device in a small fraction of the time it would usually take to take it to the engraver's, not to mention possible delays when there, and the reasonable time it takes to cut a piece of engraving by hand.

The design to be cut by this instrument must be distinctly and accurately traced or sketched on the metal, or whatever substance it is, before the graver is set at work. Consequently either the operator must know how to sketch his work well, or he must use some transfer process, which will be sufficiently clear and distinct to follow during rapid work.

The best transfer process I have ever seen is that of the inventor of the engraving instrument. He has been very successful in producing a means of sketching on metal as delicate and accurate as can be done by the photograph, and distinct enough to be followed by hand or machine. Ordinary printing types can be used in this transfer process, with results almost astonishing in their fidelity to copy and in their practical distinctness.

This engraving instrument, supplemented with this transfer process, is, in my opinion, the most practical substitute for hand work which I have seen, and I predict that jewelers and even professional engravers will avail themselves of its aid when they see its utility demonstrated. It is so cheap, so simple, so ready to work on almost anything and so little liable to get out of order, that those who have held engraving machines in suspicion and distrust will probably find many points in this one to approve.

On the Use of Anti-Magnetic Compensation Balances and Hair-Springs.

By A. HOFFER, Geneva, Switzerland.



HERE is no doubt that many anti-magnetic watches are now being sold in North America, and that in the very near future we shall hear of a large demand for good timekeepers provided with compensation balances and hair-springs uninfluenced by magnetism. It has been found by scientific horologists after a good many years of experience that the regular steel and brass compensation balance and steel hair-springs can both be made nearly perfect for the adjusting of watches of all kinds, and specially for pocket chronometers made to go through very severe observatory tests as well for the compensation as for the adjusting of the positions and wear in the pocket, and considering these accomplished facts watch companies and watchmakers in general will not give them up unless they are compelled to.

A great many anti-magnetic watches are actually manufactured with the steel parts of the movement highly magnetized. Such

watches when given for cleaning or repairing to inexperienced watch jobbers who do not take special care will, through being handled together with watches provided with the ordinary compensation balances and steel hair-springs, do a great deal of mischief to the latter watches, that is to say, they will put the adjusting entirely out of order, and therefore bring perplexity to the watch jobber, who is unable to find out this invisible break, which can only be easily detected by experienced adjusters familiar with watches having the compensation balance, steel hair-spring or escapement more or less magnetized.

Magnetized watches can be demagnetized at a certain cost, but as it is only a temporary cure it would seem more practical in this case to put in practice the old English proverb that an ounce of prevention is worth a pound of cure, and provide watches made so that their performance will not be influenced by magnetic action, i. e., with both an anti-magnetic compensation balance and hair-spring. Anti-magnetic compensation balances, besides being made so as to be adjusted for the most severe tests in the extreme and mean temperatures, must also have great elasticity in the rim, which must not get out of shape too easily from outside pressure. In fact, the rim of an anti-magnetic compensation balance can scarcely have too great resistance in that way. Every anti-magnetic compensation balance soft in the rim or adjusted with platina screws near the curbing ought to be summarily rejected by all watchmakers, as such balances are apt to be considerably thrown out of poise by the least bending of the rim, or some other cause. The best made timekeeper provided with an anti-magnetic compensation balance soft in the rim or adjusted with platina screws near the curbing, would in many cases after leaving the cleverest adjuster's hands never give satisfactory results and be declared worthless.

Very well made anti-magnetic balance hair-springs, possessing as much elasticity as the best roll hardened steel hair-springs, with a specific weight very near that of steel are proved by experience, both scientific and practical, to answer advantageously for the adjusting of the compensation, positions, and not to alter the watch's daily rate provided the movement be free from all mechanical imperfections and the oil also keeps in good condition.

The conditions required for first-class anti-magnetic compensation balances and hair-springs are claimed for the Usine Genevoise de Dégrossissage d' Or, Geneva, Switzerland, on which patents have been granted in the United States, Canada, several European countries in 1888, and lately in England. The invention consists in forming the inner blade of the balance of an alloy of platinum, nickel, copper and cadmium, or of platinum, nickel, copper, cobalt and cadmium, in suitable proportions. The outer blade is composed of an alloy of cadmium and silver, or of copper, cadmium and silver, also in suitable proportions.

Very close first-class certificates of rates (published in the *Journal Suisse d'Horlogerie*, Mars, 1889, page 239, *Concours pour le réglage des Chronomètres à l'Observatoire de Genève en 1888*) were obtained last year with pocket chronometers provided with the said patented compensation balance and hair-spring at the Geneva Official Observatory.

GOLD IN CABINETS.—Although we no longer hide our savings in stockings, as our forefathers used to do, it is astonishing how much gold in the shape of coins is laid by and out of use in the cabinets of the collectors. It has been calculated, for instance, that the result of issuing a Jubilee coinage in England has been to withhold from circulation about half a million pounds (\$2,500,000) of gold. The mint of England lately issued a quarter of a million pounds' worth of five-pound pieces, and nearly the same value of two-pound pieces, and these are never seen except as curiosities in the collector's cabinet. It is also certain that a number of minor coins will also be preserved as memorials of the Jubilee year.



PARIS GOSSIP.

[FROM OUR SPECIAL CORRESPONDENT.]

THE FLURRY IN COPPER AND THE COMPTOIR D'ESCOMPTE.—
NOVELTIES IN PIERCED WORK.—PEARLS IN HIGH FAVOR.—A
CRUSADE AGAINST AUCTION HOUSES.—FORESHADOWINGS OF
THE COMING EVENT.

PARIS, April 10, 1889.

Trade has been rather dull lately. The suicide of M. Denfert-Rochereau, the Comptoir d'Escompte's manager, frenzied by the sudden fall in the Société Auxiliaire des Metaux's shares, caused a panic, which for a few days past has paralyzed business of all kinds. But, happily, the intelligent and opportune interference of M. Rouvier, our Ministre des Finances, quickly restored the public confidence. The shareholders of the mismanaged bank, whose defunct director thought it advisable to support the famous copper syndicate, will be the only losers, and there is every reason to believe that the effect of this terrible shock will soon subside. The true cause of the present dullness is, no doubt, that our retailers intend to postpone their purchases until the opening of the Exhibition. Provincial jewelers say that they will come to Paris in May or June and have a look at the novelties in the Champ de Mars. They will also pay a visit to the manufacturers, where they expect to find something out of the ordinary. We ought not to be surprised to see no anxiety on the part of the country retailers to buy just yet, since even if they were sure to get at once what will sell this year, they feel confident that their own customers are bound to come to the Exhibition, and consequently will purchase nothing in the provinces, at least before the winter season. The orders received at present are all for weddings. Let us hope that they will soon increase. It ought to be the case, as we are nearing Easter, immediately after which comes the time for marriages, according to the dictates of high society.

The Eiffel Tower, which has now attained its normal height, and looks at a distance like giant iron lace work, has been causing lately a great disturbance among the numerous manufacturers engaged in making portable copies of it. Yaluzot & Co., proprietors of the Printemps, a daring rival of the Magasins du Louvre and du Bon Marché, have alone (so they say) acquired the right of reproducing the tower in any material and size whatsoever. Accordingly they have conceded a part of their right to various firms, one of which is in the jewelry line. On the other hand, many manufacturers who did not know anything about these agreements made a large quantity of similar articles, especially in the cheap lines (oxidized silver, etc.), and as soon as they began selling them they were threatened with an action for damages. At last M. Eiffel, being appealed to, wrote to Yaluzot & Co. with the object of cancelling his contract, but the Printemps' proprietors answered that they were not at liberty to do so. It is to be hoped that all will end well.

Some pretty articles in pierced work resting on enamel are coming out. Cuff links represent curling ornaments either in chased or engraved gold with their intervals showing a blue background. A light foliage with a tiny bird or insect is still more attractive, especially if made of different colored gold, such as yellow, red and green, tastefully contrasted by an artist jeweler. Lockets, brooches and even pendant ear rings in the same style look very elegant.

Very fashionable is a gold ball paved with brilliants. I have seen a diamond setter at work on one of them. About 150 of those tiny stones, the whole weighing six karats, are employed, as a rule, for each ball. The sparkling spheres are usually worn as hat pins' heads, but they can be detached and hung at a bracelet, a chain regence, etc.

Pearls seem to be in high favor among our aristocracy. Mlle. de Clermont-Tonnerre received a lovely pearl necklace on the occasion

of her marriage with the Count de Marcieu. I never could understand an exclusive preference for any of these lovely things which ought all to have a share in our admiration. Who would be so partial to one flower that he could not think of having any other in his conservatory? I do not believe that even the staunchest Boulangist would insist upon his gardener devoting all his time and attention to "the only" pink. I can still less imagine that a lady, however anxious she might be of proving her taste and refinement by choosing pearls as the most aristocratic of jewels, could overlook those other peerless gems, the diamond and ruby.

At an evening party given by the Princess de Hohenloe, recently returned to Paris, the Baroness de Scotti was dressed like Dona Maria de Neubourg (in Ruy Blas). She had a white brocade robe with a front of pale pink satin showing through a veil of beautiful lace. Diamond pins held this delicate work, and feathers sparkling with a powder of brilliants adorned her hair.

Public sales have for a long time proved formidable competitors to jewelers and precious stone dealers, who have carefully followed their proceedings with the hope of finding some day or other a flaw in them. Something of this sort occurred lately which attracted the Jewelers' Chambre Syndicale, and accordingly M. Boucheron wrote a very strong letter to M. Bivort, President of the Merchandises' Auctioneers. The writer said that in most of the late public sales something very irregular had taken place, viz., that an important difference had existed between the real weight of precious stones and the figures put down in the catalogues. Consequently jewelers, as anxious as they ought to be to see strict honesty prevail in all dealings, had come to the following conclusion: it would be advisable to divide goods for sale into three categories. The first to include only stones unset. In the second lot should be all the gems which, in spite of being mounted, could be valued as to their weight from commercial documents. The third one would contain jewels, the origin of which cannot be easily traced, and whose real weight was not accurately obtained from their owners. The goods being thus classified according to the wish of the Jewelers' Chambre Syndicale, information about them should be given to the public as follows: The catalogue ought to mention the exact weight of all unset stones composing the first lot. For the second one, it should be indicated in karats with fractions, and the word *about* might be used to imply a difference never to exceed $\frac{1}{8}$ of a karat. As to the third lot, no weight could be announced. M. Falco, President of the Diamond Dealers' Board, also wrote to M. Bivort, who promised in his answer to see that the jewelers' wishes should be gratified as far as possible.

The Bijoutiers' ball has been what I expected, I mean a real success. Ladies were not adorned with flowers only, but sparkled with jewelry. There were, perhaps, too many crescents. Feathers bedewed with brilliants may have been more plentiful than necessary, but we could not very well hope to see decided novelties appear on that occasion. To show that jewels must not be despised, even by jewelers' wives, was the one important thing.

Although exhibitors are seldom inclined to show their work before the appointed time comes, I have been able to obtain a pretty close inspection of a few of the most interesting pieces in the jewelry department. I particularly admired a good-sized board, rectangular in shape, but with the angles rounded. It shows four scenes which represent a ball given to the people at Versailles during the reign of Louis XV. On the two opposite sides, in the length, are seen the dancers displaying all their grace in the middle of a splendid ball room. On the two narrow sides some of the guests are in the act of assailing the buffets in the most life-like manner. On the center of the board reigns an elongated sun, shooting its rays in all directions. More than two years were spent on this piece, which includes about four hundred figures. The work was done in aquafortis, finished off with etching and ramolayé (rounding the angles through chasing), and will show with fine effect in the glass case of M. Boucheron.

JASEUR

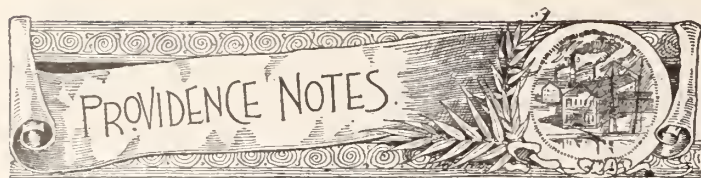

[FROM OUR SPECIAL CORRESPONDENT.]

PROVIDENCE, R. I., April 15, 1888.

The old saying of "April showers bring May flowers" is possibly true, but what the manufacturer would like to know at present more than any thing else is, what will bring April orders to hand? That is the all-absorbing and uppermost topic in his mind to-day, as he finds his works generally running on short time with a reduced number of employees. He is looking around anxiously to see if he can solve satisfactorily to himself the knotty problem of dull business for the past six weeks or two months, for dull it has been, and you will hardly find a firm but will admit that it has been an extremely dull Spring thus far. Not that new lines of goods have not been handsome and all that the trade could possibly wish for. They have never been finer or more extensive and the prices more reasonable. Drummers on the road West at present report the hardest kind of times in making sales, and say that there is positively nothing doing with the jobber, and are being "turned down" right and left by their best customers, who never thought of doing so before, all because they cannot move the goods should they even place a small order. Many trips have been made to the West this year so far that have not paid expense, to say nothing of profit. The true reason for all this dulness, must be sought elsewhere, possibly in the general dulness of trade throughout the country. Collections seem to be fair at present, and failures are few, and for small amounts generally.

Clarence L. Watson is rustivating down South for the benefit of his health.

James A. Cushman has been appointed administrator of the estate of the late Charles F. Boehue.

Jos. G. Matthews, formerly in the jewelry business, died on Saturday last.

The stock of C. Robert Linke was sold by assignee Fink, on Wednesday, but did not net enough to pay a dividend on the liabilities.

Hearn & Braitsch of Broad street, have presented to Perseverance Lodge, I. O. O. F., a gold-headed cane to be voted for at their coming fair.

The new Champlin Building on the corner of Chestnut and Clifford streets is about finished, and on or about May 1st will be occupied, the first floor by the owners, and the others by the following named firms: W. L. Ballou & Co., N. B. Nickerson & Co., and E. S. Dodge. The building has two entrances, one on Clifford and the other on Chestnut st., and is provided with a hydraulic elevator for the convenience of the upper floor tenants. Other landlords would do well to imitate them in this respect.

J. M. Chandler, of Cleveland, Ohio, was in the city on business the past week.

Ostby & Barton will, about the 1st of June, occupy the two floors in the John Austin Building, at No. 822 Clifford street, to extend their business, as they find their present quarters inadequate to their wants.

Mr. Lauriston Towne, formerly of Dunham, Towne & Co., has met with a sad affliction in the loss of his daughter.

The regular quarterly meeting of the Manufacturing Jewelers' Board of Trade was held in Room No. 9, Wilcox Building, at No. 42 Weybosset street, on Saturday, March 30th, at 1.30 P. M.

Mrs. Ladd, wife of Gov.-elect Ladd, died at her residence on Waterman street, on Saturday morning, the 13th inst., and the funeral was held on Tuesday, the 16th, at 12 noon.

Alexander & Co. have removed from No. 23 Dorrance st., to No. 34 same street.

Hiram Howard, of Howard & Son, has returned from the South

where he has been on a short trip for the benefit of his wife's health. He returned just about in time to receive the news of his election to the General Assembly.

Hoffman S. Dorchester, treasurer of the Manufacturing Jewelers' Board of Trade, was elected quartermaster sergeant of the Gen. Garfield Camp of Sons of Veterans at its formation on Saturday.

George Hutchison and J. L. A. Fowler left here on the 14th inst., via Blackstone and the Washington express for a few days' sojourn in New York state on a trout fishing expedition. Look out for some large fish stories when they return.

William C. Greene, manufacturing jeweler of this city, has met with a sad loss in the death of his mother at East Greenwich, R. I., on the 20th ult., of pneumonia, at the ripe age of 95 years.

R. A. Kipling, the stone importer, leaves for Paris on business about the 10th of May. He will take a Cunarder from Boston to avoid the crush which is expected on the French line during the Exposition season. He has crossed about thirty times per steamers of the French line.

Amongst the many ward delegates chosen at the late election, the following well-known jewelers were noticed: H. S. Dorchester, G. H. Wood, W. H. Luther, Chas. Downs, and R. S. Hamilton.

Col. Isaac L. Goff has severed his connection with W. R. Richards, and entered the real estate business.

Hon. Chas. Sidney Smith declined the honor of a renomination as state senator.

John Hoagland, the pen and pencil manufacturer, has formed a co-partnership with F. W. Holmes, of New York, and will continue the business formerly conducted in this city, at No. 95 Cliff street, New York City, under the firm name of Hoagland & Holmes, closing their works in this city.

The creditors of the firm of I. N. Heims, of Indianapolis, located here, expect to receive about 33 per cent. of their claims.

The failure of Pond, Wilmes & Co., of Kansas City, is announced. Manufacturers here are in for about \$5,000. The firm claims to have a capital of about \$24,000; stock \$16,800, and the balance in real estate free from debt.

George H. Wood, of Wood, Bicknell & Potter, sailed per steamer *Lahn*, on Wednesday, on business connected with the firm.

Chas. Downs left on Saturday for the South on a pleasure trip, per a steamer of the Norfolk line.

FAIRFAX.

A New-Fangled Wedding Ring.

THERE is a constant demand for novelties in wedding rings nowadays as well as in every other article of luxury, and a jeweler has to meet the demand or lose the very desirable custom of young couples contemplating matrimony. This season has brought forth the most curious and beautiful wedding rings yet designed by the trade. One especially looks just like any other ring, the only difference being that it has a crooked scratch across the surface. But when a tiny pair of jeweler's pincers are thrust into the inner edge of the ring opposite what appears to be the scratch, and the needle pressed lightly, instantly the ring drops into one's hand transformed into tiny hoops of gold looped together. The needle split the ring into two halves, each half having a flat, broad edge. These flat surfaces are designed for the purpose of being engraved with any tender or romantic inscription that the bride or groom desires to have placed upon the ring, and they will contain much more than can be put upon the inner surface of an ordinary ring. After the engraving is done the ring is closed again by fitting the two hoops together, and locking them securely by a concealed latch fitted on the inner edge of the hoop. It requires the closest scrutiny to discover that the ring is not an ordinary hoop of gold. These rings have made a big hit. One of them was used at a swell society marriage in a Fifth avenue church the other day. The society belle who was the bride made the selection herself.—*N. Y. Sun.*

Fashions in Jewelry

A Lady's Rambles Among the Jewelers.

EASTER, the spring festival, received a joyous welcome after the long dull quiet of Lent, and in many families Easter gifts were made. The custom of exchanging gifts about Easter time has gained of late years a sufficient number of advocates to warrant our jewelers and silversmiths in adopting the plan observed abroad of placing in show cases and shop windows articles designated as "Easter offerings."

* * * * *

ALTHOUGH the Easter season is a very brief one, many of the so-called "Easter offerings" have a permanent value which renders them of use throughout the year. This fact, in part, at least, accounted for the unusual display of articles suited to the times made by all our leading retail houses this year.

* * * * *

ECCLESIASTICAL goods, including church plate for the service of the various denominations, always in more or less demand, naturally assume additional importance on the approach of Easter-tide, and form a conspicuous feature of the Easter exhibitions at houses where those goods are made.

* * * * *

THE enormous proportions which the ecclesiastical department has assumed in the silversmith's trade, is faintly indicated by the statement made by the manager of one of these departments, that "the list of articles kept in stock numbered nearly one hundred, and included everything needed in the various churches' religious observances and in their decorations." These articles are, many of them, made in brass, though the communion service plate is, of course, in silver, when not of gold.

* * * * *

PRAYER books and hymnals have been a conspicuous feature of late, with their artistically wrought silver covers, or covers of leather with silver mounts. A pleasing style is represented in silver covers which expose the colored leather binding underneath. The white stamped leather, not unlike ivory in appearance, and showing silver or gold trimmings, is another attractive style in book bindings.

* * * * *

EASTER presents take on in many cases the form of eggs, as well as fish. Bonbons are sent in boxes formed like nests, with three eggs and a bird of some kind on the top. Egg-shaped bonbonnières of Oriental porcelain, fancy bonbon bags, pails, tubs, jardinières and vases of choice porcelain swell the list. Sometimes these bonbonnières are simply filled with bonbons, and oftentimes they conceal a welcome gift.

* * * * *

BONBON boxes were out, as usual, in form of gold and silver eggs, some bearing a scriptural inscription or floral etching, while others were quite plain.

EGG racks of Minton's wares, basket-like dishes of china for holding egg and fancy egg cups, proved acceptable gifts to housewives. Then there were pepper and salts in form of eggs, as well as sugar sifters and tea balls.

* * * * *

EASTER day being essentially a feast of flowers, flower jewelry flourished during the short Easter season. Highest among these was the lily, both that oldest known species "Easter lily," and the modern "Calla" being represented in jewelry.

* * * * *

FLORAL jewelry has been by no means restricted to the lily for a model; all the popular early spring blossoms are simulated in gold, silver and enamel. The passion flower, the golden genista, lilies-of-the-valley, yellow daffodils, etc., etc., are all included.

* * * * *

A DAINTY article, of French design, wherein a flower is imitated in enameled metal, is a scent bottle in the form of a tulip, with leaves and stem, the perfume being contained within a chalice formed by the petals of the flowers.

* * * * *

A DEVICE serving the three-fold purpose of Easter, and wedding gift and brooch, represented two diamond ducklings feeding on enameled green peas from a golden basket.

* * * * *

DURING the past month bird ornaments have vied with floral ones for popularity. Chicks, quails, swallows, pheasants and others of the feathered tribe, cunningly copied in diamonds or wrought in enamel or gold, have been as plentiful as roses in June. Brooches formed of a golden twig, with two enameled birds and a tiny nest resting thereon, proved popular, especially when the nest contained three egg-shaped pearls.

* * * * *

THE reign of enamel is widespread, and our jewelers may well be proud of the wonderful perfection attained in this direction. This style of ornamentation appears alike on floral and bird jewelry, and jewelry in original designs.

* * * * *

CANDELABRA and candlesticks are more or less associated with Easter, and these standards for lights have consequently been included among articles always desirable, but particularly so as Easter wedding gifts. In the shops are seen now quite a diversity of patterns, for our own manufacturers are no longer content to copy English designs.

* * * * *

DECORATIVE glassware and china, which have become important accessories to every progressive jeweler's stock, at this season attract unusual attention. The list from which to make selections is a remarkably extensive one. There are choice cabinet pieces in royal Dresden, small Dresden boxes for bonbons, jewelry or stamps, Sevres china and Berlin reproductions in way of vases and mantel ornaments, and vases, and urns, and pitchers of Worcester.



Towle Mfg. Co.,

MANUFACTURERS OF

STERLING · SILVER · WARE,

NEWBURYPORT, MASS.: 214 MERRIMACK STREET.

CHICAGO: 149 & 151 STATE STREET.

SAN FRANCISCO: 220 SUTTER STREET.



YOU
NEED IT

It costs but little, is convenient in use, perfect in action, and made to fit all standard sizes.

PRICE
Reduced
to only
\$1.00

Ask your Jeweler
for it.
Sample sent by mail
on receipt of price.

Even though a man never goes near a dynamo or electric railway, he meets every day and all day magnetic influences that will affect the running of so delicate a piece of machinery as a watch, and the finer the watch the more susceptible to magnetic influences. In the Keystone Dust-proof Watches the balance wheel makes 300 vibrations a minute or 432,000 a day, and a slight alteration in the length of each beat makes a great variation in time. The Ajax Watch Insulator will enable you to defy magnetic influences.

IS THE BEST GOOD ENOUGH FOR YOU?



ARE
THE
BEST

BECAUSE They contain everything essential to Accurate Time Keeping found in any watch, and in addition have the following important patented improvements, which appear only in Keystone Watches:
The **PATENT DUST PROOF** protects perfectly the balance and hair spring (the most delicate and vital parts) from damage, dirt and dampness.
The **PATENT COMPOUND REGULATOR** has absolutely no lost motion.
The **PATENT STEM WIND** is the strongest and simplest made.
The **PATENT DUST-PROOF MOVEMENTS** are free from all variations caused by dirt or dampness; an advantage which no other maker dares claim.
This is the only Factory using only **Genuine Ruby Jewels** in every grade, and all Keystone Watches are made of the best material, and are accurate time keepers, under our own guarantee.

Send for Samples, giving Reference.

ATKINSON BROS.

931 Chestnut Street, Phila.,

SOLE AGENTS FOR

The Keystone Standard Watch Co.,
The Standard Stiffened Gold Watch Cases
And Ajax Watch Insulators.



The buyer of a Stiffened or Filled Gold Watch Case must depend on the honesty, skill and experience of the maker, no matter how great his own skill and experience may be. Other goods may be tested, but the only conclusive test of the wearing quality of a stiffened gold case involves its utter destruction and the eating out of the filling with acid. Costly experience has convinced the watch-maker that the largest capital and the strictest honesty, without that skill which comes only from long experience, fails to produce satisfactory cases.

The "Standard" Stiffened Gold Watch Cases are made under the direct personal supervision of Mr. T. B. Hagstoz (President of the Essex Watch Case Co.), one of the pioneers in the making of these cases. His skill comes from an experience of over twenty-eight years as a practical watch case maker. He has made more high grade stiffened and filled gold watch cases than any one else, and his honesty and integrity have never been questioned.

Mr. Hagstoz's personal guarantee that they will wear for twenty years goes with every case.

In quality, style, shape, beauty, and variety of engraving, the cases will be kept ahead of all competition.

No expense will be spared to make them in every sense the "Standard" Gold Watch Case.

L. A. CUPPIA,

42 EAST 14th STREET.

(UNION SQUARE.)

We are equipped in our new quarters with all the best and latest Machinery for Manufacturing a full line of

◀ SILVER GOODS ▶

Including as New Features:

Cane Heads, Umbrella Handles, Parasol Handles, Penholders, Small Hollow Ware, Toilet Articles and Manicure Sets of Silver with Exposed Ivory and Pearl.

Paper Cutters, Envelope Openers. All sorts of Silver Rings, Knotted, Chased, etc. Puff Combs, Combination Whistle and Match Boxes, and a full line of BANGLES.

FOR milady's dressing table are toilet sets of French china which serve as a pretty contrast to the silver manicure articles and powder boxes.

* * * * *

SINGLE candlesticks, also candelabra for dressing rooms and boudoir, come in royal Worcester, and represent fluted columns of ivory inlaid with gold, or else entwined with flower-leaf patterns. There are also some very attractive candlesticks in the blue and white German wares.

* * * * *

THERE is a very showy display in way of Venetian glass in form of graceful flacons, bottles, vases, trays and similar decorative objects that accord with the present furnishings of the "house beautiful."

* * * * *

A TOILET set of choice china on which appears a silver decoration effected by the "deposit" process, has attracted deserved attention.

* * * * *

AN ATTRACTIVE mode of decoration, termed "crystal pearl covering," is being employed on both china and glassware. In this decoration vases and other objects designed for ornament are first tinted a desirable color, and then covered with transparent glass beads, held in position by a cement made for the purpose.

* * * * *

ALONG with other revivals hastened by the interest that has of late been awakened by the Centennial celebrations, the study of ancestors and the like, are miniature paintings. Where old miniatures of celebrated court beauties or fancy heads, and done by old masters, are to be obtained, these, of course, have the preference. Everybody who possesses one or more of these paintings by inheritance is considered extremely fortunate. These old heirlooms are usually re-set, and figure as a brooch, pendant or medallion to a bracelet.

* * * * *

ALL the tiny miniatures one sees are by no means antiques. Very pretty ones are being painted every day and placed in modern antique settings, or else are rimmed around with gems.

* * * * *

A FASHION lately introduced for the better display of very choice gems, and thought by many to be "something new under the sun," is, in point of fact, a modification of an old style indulged in by English dames many, many years ago. The fashion is for an owner of fine gems to match her own fair or dark tresses, as the case chances to be, with bands of hair, to which single stones, set in gold or silver, are securely attached. These gem-laden bands are threaded in with the *coiffure* and produce a decidedly novel effect. The old fashion alluded to was that of fine hair nets studded with gems and put on over the natural *coiffure*.

* * * * *

SPEAKING of revivals, it is again rumored that the coral is coming back. An English authority makes the statement without reservation of any kind, that "pale pink coral will be worn during the summer season with colored toilets."

IN MARKING social events, such as weddings, engagements and birthdays, the "date" jewelry, so popular in medium priced goods abroad, is gaining some favor here. Bracelets, bangles and brooches are all represented. The "1889" appears in gold or silver cord and wire, and is also outlined with small diamonds, pearls or other stones.

* * * * *

THE "knot" pattern presents some quite new and graceful entanglements. Some cuff buttons seen recently were composed of a knot tied with two styles of gold cord in such a manner as to produce a square.

* * * * *

THE "Union knot" is a popular pattern in both gold and silver jewelry. The bangle or ring in which it appears is apparently held together by a loose knot.

* * * * *

THERE are many really quite original ideas expressed in designs bearing time-honored names. For instance, one of the prettiest, and, at the same time, newest bangles seen last month was dependent for its ornamentation on a horseshoe. The bracelet was of round gold wire; it was held together with a silver horseshoe studded with different hued stones to represent the nail heads, and further embellished by three pearls that were grouped in the open curve of the shoe.

* * * * *

NUMBERED with quite new sleeve buttons are silver ones, showing light and dark shades by oxidizing, and inlaid with gold in tiny floral designs. Other silver buttons seen in the same show case were ornamented with applied gold decorations. Still others showed the white finish and had garlands of gold flowers inlaid about their edges; these last had been christened "Bridal Buttons."

* * * * *

A NOVELTY in initial jewelry consists of cuff buttons of Roman gold, with a plain open letter enameled in the center. The purchaser selects a button bearing a letter representing his surname, and the jeweler engraves inside this enameled one the initial of said purchaser's given name. The result is an effective and ornamental monogram.

* * * * *

SLEEVE buttons decorated with an initial letter in rustic work, are as popular as ever. This rustic work is too well known to the trade to necessitate a description, having been the subject of a long and famous law suit in the protection of its patent.

* * * * *

THE tendency in all gold jewelry to more ornate designs and heavy, massive effects, is apparent in the new jewelry. One again sees the large heavy curb links in both bracelets and men's watch chains. This style of work does not appear to in any way affect the popularity of simpler patterns. One has but to look into the show cases to see these extremes lying side by side.

* * * * *

GEM jewelry is made in a great diversity of patterns. Each manufacturer endeavors to bring as many changes as is possible in the grouping of colors and placing of the stones, whether these be real gems or semi-precious ones.

A MAGNIFICENT ornament to wear as a brooch, a pendant or in the hair, is composed of four diamond crescents set with the points outward so as to form a square; in the center glows a rich-hued ruby of large size.



GEM-SET horseshoes are placed in groups of three, and furnish unique, and, at the same time, costly brooches or pendants.



DOUBLE hearts held together with a little gold arrow, continue to figure on bracelets and pendants.



STARS remain a favorite design in gem jewelry.



LADY-BIRDS, butterflies, dragon flies and other winged insects contrive to be cleverly imitated in gems and enamel, and figure as brooches, lace, scarf and bonnet pins.



IN FINGER rings, where small gems are employed, the cluster is a popular setting. Sometimes two clusters are placed so as to form a long setting; again, the overlapping ends of the ring terminate in a cluster and so give a diagonal setting.



A VERY pretty, and, at the same time, popular ring, is a slender shank with a setting in which four stones appear so as to form a square; a diamond and three stones of differing color are usually employed in this setting.



QUAINT little ear screws for young misses are those in which a tiny diamond surmounted by an even smaller pearl appear.



THE demand continues for fancy stones, and the recent exhibition of American products at Tiffany & Co.'s was a revelation to many persons. There is a wealth of light and color in many of those productions that have heretofore figured little, if at all, in the show cases of our jewelers.



THE question arises whether America's own gems and semi-precious stones will not receive quite a boom this Centennial year, especially if the collection now in Paris attracts favorable notice from the visitors at the French Exposition.



THIS question suggests another, viz., is not the present a propitious time for our progressive designers and manufacturers to gain a permanent place for American art in jewelry and silverware? The efforts made in this direction by some of our best known firms for the Exposition, resulted in a great diversity of articles that cannot fail to command admiration, not only for their striking originality of design and high order of workmanship, but for their beauty and general attractiveness.

FINE color harmonies are obtained by combining the different stones. A bracelet that beautifully illustrates the effect of a diversity of tints shown together is composed of links, each bearing a different gem and including topazes, emeralds, sapphires, tourmalines, garnets, hyacinths, etc.



THE opal, which a modern writer terms the feminine of the diamond, the queen of gems, as the diamond is king, is once more being not only admired, but worn, without any thought of the ill-omen so long associated with it.



THE opal is, as a rule, set with diamonds.



ENAMELED jewelry was never more in vogue. It is shown to perfection, not only in the flower pieces and in the bird and insect jewelry, but in such designs as a violin brooch or a banjo brooch, when the color of the different parts of the instrument is copied to perfection.



VERY pretty brooches in enamel take the form of open fans, unfurled parasols and bows of ribbon pierced with a gold pin.



THAT class of jewelry which combines utility with ornament, is having more or less of a run. New York ladies do not patronize it, perhaps, to the same extent as do their English cousins, still there is a fair demand for it.



FIRST on the list of this utility jewelry may be placed the watch wristlets, and the purses and card cases that contain in one corner a tiny watch dial. The pretty crystal ball watches are quite fashionable for chatelaine purposes.



LADIES are patronizing to a considerable extent scent bottle bracelets, and bangles fitted with pencil cases.



WHAT is known as the "combination buttonhook" jewelry is having something of a run. This is made of gold or silver wire, and when opened out presents a buttonhook with a handle more or less knotted or twisted; when closed this novel buttonhook is transformed into a neck pin or bracelet.



WHILE many of our manufacturers are busy providing rich and glittering ornaments to be worn on gala occasions with elaborate toilets, others are providing suitable adornments for patrons who are in mourning costumes. Conspicuous among the mourning goods is the crape stone jewelry, by this time well known throughout the length and breadth of the country. This jewelry, which represents with its corrugated and lusterless surface the exact texture of fine English crape, comes in brooches, bracelets, bonnet pins and buttons of approved shape and design. Many of the more popular patterns in gold jewelry appear in the crape stone ornaments. ELSIE BEE.

Copyrighted 1888 by Charles A. Bucklin.

Mechanical Ocular Defects.

Their Nature, Cause, Correction and Relations to Functional Nervous Diseases.

EDITED BY C. A. BUCKLIN, A. M., M. D., NEW YORK.

[The aim of the author is to produce a clear and thoroughly practical course of instruction on the subject of "mechanical ocular defects," which is entirely void of useless technicalities and within the easy comprehension of every thinking student, without his having had any previous technical or mathematical education.]

LENSES.



EXPERIENCE has taught us how to refract light in any way we desire by giving to transparent media specially curved surfaces. Our knowledge of the effect on light of transparent media having specially curved surfaces comprises the science of lens construction, which subject we will now proceed to consider.

The simplest example of an optical device for producing a specific effect on rays of light passing through it is a prism or wedge of glass; this presents a surface with a uniform slant to all direct rays of light which in their passage through the prism are all deflected from their former course toward the thick edge of the prism. The displacement of any object from its true position when viewed through a prism is amusing to one who has never observed it, the apparent position of the object becomes displaced to a position which corresponds with the direction of the rays of light as they leave the prism and enter the eye. The strength of prisms is always expressed in degrees, a prism of ten degrees indicating that the thick edge of the prism measures ten degrees of the circumference of any cylinder of glass from which the prism has been cut. Prisms simply bend all rays of light in the same direction and can consequently only be used for changing or displacing the apparent position of the retinal image, thus enabling one to cause the retinal image to fall on corresponding points on each retina when owing to a weak ocular muscle it would be very fatiguing to maintain both eyes directed at the same point.

Convex Lenses.—By giving to transparent media convex surfaces, we may give to rays of light passing through them a universal convergence, the sharpness of the convergence of parallel rays may be controlled at pleasure by increasing or decreasing the convexity of the surface. Rays of light passing through lenses of any description are always bent toward the thickest part of the lens.

On a convex surface of glass there is one point in the center of the lens where a direct ray passes through without being refracted the least distance from this central point and the rays of light face on a convex surface. At the center there was no effect on the light which passed through. The nearer the center, the less the rays are converged, and the greater the distance from the center, the sharper the convergence of the rays of light are as they pass through. In strong convex lenses the confusion arising from different portions of a true convex surface acting differently on light is very great, the defect is called "*spherical aberration*" and is usually avoided by a diaphragm which allows light to fall on the central portions of the lens but excludes it from the outer margins.

"*Chromatic and Spherical Aberration*" are two defects which exist in every simple convex lens. Chromatic aberration will be carefully described as it exists in the eye.

Although the convex lens has been used as illustrating the refraction of, and effects exerted on light by its passage through transparent media with spherical surfaces, still it must again be considered with other lenses under the general head of *Lenses*.

Lenses. *Simple Lenses* are divided into two general classes, namely: *spherical* and *cylindrical* lenses.

Spherical lenses have a variety of forms, but the surfaces of all spherical lenses are ground either on the concave or convex surface of some sphere. *Cylindrical* lenses are ground on the convex or

concave surface of some cylinder. The axis of the cylindrical lens corresponds to the axis of the cylindrical surface upon which the lens was ground. The line of axis of a cylindrical lens presents a plain surface, consequently light is not acted upon by cylindrical lenses in the line of their axes.

Spherical lenses are divided into two distinct, general classes, *concave* and *convex*. These qualities are usually indicated by the + or — sign, + indicating *convex* and — *concave*. Spherical lenses have three varieties, those having double spherical surfaces of the same kind are called *double convex* or *double concave*. The second variety of spherical lenses are *plano concave* and *convex*, which are not in general use.

The third variety of spherical lenses are *periscopic* convex and concave lenses.

These lenses have spherical surfaces on each side which are unlike in being convex on one side and concave on the other. When the convexity is in excess the lens is periscopic convex. When the concavity is in excess the lens is periscopic concave. This variety of spherical lens is in general use.

Cylindrical Lenses are divided into convex and concave lenses and as simple cylindrical lenses they have no further sub-divisions.

Compound Lenses.—Two cylinders may be joined with their axes crossed at right angles. It was formerly supposed that these were required crossed at all possible angles. A cylinder may be joined to a spherical lens; this gives rise to a number of forms of compound lenses, called spherocylindrical lenses.

Compound Convex Cylinders.—They consist of two convex cylinders axes crossed. These lenses all have spherocylindrical equivalents the nature of which can be determined by direct trials with the patient.

Compound Concave Cylinders.—They consist of two concave cylinders, with their axes crossed. They also have spherocylindrical equivalents which can be determined by direct trial on the patient.

Crossed or Mixed Cylinders.—They consist of a concave cylinder joined to a convex cylinder with their axes crossed. They have spherocylindrical equivalents *which can not be determined by direct trial on the patient*, but having determined the two cylinders required the spherocylindrical lens which would produce the same effect may be readily estimated. It is thus seen that the only condition which requires the use of two cylinders before the eye in making a trial test is that condition where one meridian of the eye requires a convex correction, while the meridian at right angles to it requires a concave correction. This is the only class of patients requiring concave or convex lenses who will absolutely reject all spherical lenses during the trial test. The reason of this is that a spherical lens as fast as it corrects one meridian, makes the opposite meridian proportionately more faulty. With two cylinders you can obtain the best possible correction in one meridian, and then without disturbing the meridian corrected, you correct the opposite meridian with the other cylinder.

Crossed cylinders are very expensive, very difficult to grind correctly, and when completed there is no possible margin for adjustment. If one axis is faulty, and you attempt to bend the frame or twist the lens for the purpose of correcting the faulty axis of one cylinder, the axis of the other cylinder simply becomes faulty. In simple cylinders or spherocylinders you always have at least three-sixteenths of an inch each way to make good any possible mistake the grinder may have made. I find that when cylinders are ordered at any axis, except vertical or horizontal, you never can depend on their being correct within five degrees, consequently the ability to adjust them is of great advantage.

I have not been able to find a case requiring crossed cylinders at any angles that could not see equally well through a spherocylinder the value of which was determined experimentally or computed theoretically.

When cylinders of opposite values have been ordered with their axes at less than right angles the operator has simply lessened the values of the cylinders by placing them in this position. The prin-

principal meridians of refraction of the combination still remains at *right angles*, which is easily demonstrated by experiment.

When cylinders of the same kind are set at other than right angles the strength of the cylinders has been changed. Cylinders of other values set at right angles will produce effects similar but more satisfactory than the original cylinders which were not set at right angles.

The following is a list of simple and combined lenses :

Simple Spherical Lenses.

Convex or + lenses.	Concave or — lenses.
Double convex.	Double concave.
Periscopic convex.	Periscopic concave.
Plano convex.	Plano concave.

Simple Cylindrical Lenses.

Plano convex cylinders.	Plano concave cylinders.
Always called simple convex cylinders.	Called simple concave cylinders.

Compound Lenses.

Compound convex cylinders,	Compound concave cylinders.
Convex sphero cylinders.	Concave sphero cylinders.
[These forms are all compound cylinders because the sign before both lenses of the combination is the same.]	

Mixed Lenses.

Convex sphere joined to a concave cylinder.
Concave sphere joined to a convex cylinder.
[Called mixed because spheres are joined to cylinders the signs of which are unlike.]

Crossed Cylinders.

Convex cylinders joined to concave cylinders or *vice-versa*. Prisms of all degrees may also be joined to any of these lenses.

PRACTICAL SCHOOL OF OPTICS.—Owing to the difficulty in obtaining accommodations in the city during the Centennial celebration, the date of class which was to form April 30th was changed to April 15th. The class filled promptly.

The following is a list of the names of those who joined this class: Samuel S. Grant, Montreal; Ansel E. Fox, Greene, N. Y.; James S. Holmes, Jr., Newark, N. J.; Richard S. Eldrich, Hartford, Conn.; Albert B. Parker, Norristown, Pa.; Edwin T. James, Sing Sing, N. Y.; John H. Leyson, Butte City, Mon.; Elizabeth A. Gill, Lancaster, Pa.; Melvin U. Foster, Omaha, Neb.

Next class commences May 9th, at 2 P. M.

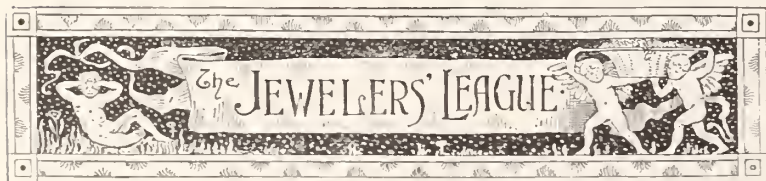

President, HENRY HAYES.....Of The Brooklyn Watch Case Co.
 First Vice-President, JAMES P. SNOW.....Of G. & S. Owen & Co.
 Second Vice-President, ROBERT A. JOHNSON.....Of Celluloid Enamel Co.
 Third Vice-President, JOSEPH B. BOWDEN.....Of J. B. Bowden & Co.
 Fourth Vice-President, CHARLES G. LEWIS.....Of Randel, Baremore & Billings.
 Secretary and Treasurer, WILLIAM L. SEXTON.....Of Sexton Bros. & Washburn.

EXECUTIVE COMMITTEE.

GEO. H. HOUGHTON.....With Gorham Mfg. Co.
 WM. H. JENKS.....With Tiffany & Co.
 A. A. JEANNOT.....Of Jeannot & Shiebler.
 GEORGE R. HOWE.....Of Carter, Sloan & Co.
 WM. BARDEL.....Of Heller & Bardel.
 J. R. GREASON.....Of J. R. Greason & Co.

At the regular monthly meeting of the Executive Committee of the League, held Friday, April 5th, there were present Chairman George R. Howe, Vice-President Snow, and Messrs. Jeannot, Greason and Sexton.

There were seven (7) changes of beneficiaries granted, and the

following applicants were admitted to membership: Albert E. Frederick, Louisville, Ky., proposed by Leonard Huber; Richard V. Gollnitz, Charleston, So. Car., proposed by E. Rosenthal; David Kaiser, New York City, proposed by Adolph Luthy and Fred. L. Smith; W. Lichtenstein, Meridian, Miss., proposed by Charles Silvesterstein; Ira W. Shattuck, Brooklyn, N. Y., proposed by James P. Snow and H. C. Ostrander; and Frank E. Whitmarsh, New York City, proposed by W. H. Tripp.

On the Values of some of the Rarer Minerals.

BY GEO. F. KUNZ.



THE misleading table below, culled from the market report of a recent issue of a technical contemporary, giving the current prices of some of the rarer metals, has been widely quoted in trade and class journals, exciting almost unanimous expressions of wonder, as bearing evidence of the existence of metal whose values are greater than those of gold and silver, \$319 and \$19 per pound, respectively.

Barium, per lb.....	\$ 975
Calcium, per oz.....	150
Cerium, per oz.....	160
Chromium, per lb.....	200
Didymium, per oz.....	160
Erbium, per oz.....	140
Gallium, per oz.....	3,250
Glucinum, per oz.....	250
Indium, per oz.....	158
Iridium, per lb.....	650
Lanthanum, per oz.....	175
Lithium, (metallic) per oz.....	160
Niobium, per oz.....	128
Osmium, per lb.....	640
Palladium, per lb.....	400
Platinum, per lb.....	140
Potassium, per lb.....	38
Rhodium, per lb.....	512
Ruthenium, per oz.....	112
Rubidium, per oz.....	200
Strontium, per oz.....	128
Tantallum, per oz.....	144
Thorium, per oz.....	272
Vanadium, per oz.....	320
Yttrium, per oz.....	144
Zirconium, per oz.....	240

Numerous other metals could be added to the list, some being perhaps of greater utility than any enumerated. As the list stands, osmium, palladium, platinum and zirconium are the only metals that possess real values, for their intrinsic values are great, and much benefit would be derived from their extensive use. As to the remaining metals, their practical utility is *nil*, excepting as laboratory specimens, a grain in this use sufficing as much as a pound. One thousand pounds of any of them, would command no sale, and if it did, could not realize perhaps \$10 per pound.

As to the much discussed metal, aluminum—the “coming metal”—when we remember that its specific gravity is approximately one-fourth that of silver, it is far cheaper than that metal, one-fourth of a pound equalling in bulk one pound of silver, being purchasable for 90 cents.

Several metals once rare are now found by the ton; among these are zircon, samarskite, gadolinite, and monazite, the latter being in largest demand, owing to the rare earths, thoria, glucinia, zirconia, etc., that it contains and which render it particularly adapted for the manufacture of the mantle or hood of the new incandescent gas burner, called the “Welsbach,” invented by Dr. Carl Auer.

Electricity and Magnetism,*

AS AFFECTING THE PERFORMANCE OF WATCHES.

A brief statement of the general principles of electricity and magnetism, with a review of the various ways in which they can injuriously affect the performance of watches, and of the different methods employed for preventing or remedying such effects.

BY "EXCELSIOR."

Continued from page 63, April, 1889.

IN WHAT ways can electricity or electric currents affect the performance of watches? I will give the supposed ways in quotation marks and then consider them.

1. *Static charge.* "Bodies charged with electricity attract and repel each other. If a watch became charged, there might be electrical attraction and repulsion between adjacent parts, which might affect the motion of the balance." To this I would answer that there can be no attraction except between oppositely charged bodies, *i. e.*, one charged with positive and the other with negative electricity. There is no part in the watch which could by any possibility become charged oppositely to the adjacent parts, because there is none which is sufficiently well insulated to take such a charge. Our detector needles could hold a charge because they are touched only by air and the silk suspension, both of which are good insulators, *i. e.*, practically non-conductors of electricity. But every part in a watch has metallic connection with the others, and opposite charges would flow through the connections, meet and neutralize each other—or, rather, the electricity would flow together so instantaneously that no "charge" could be given to the parts. And no charge could be "induced" in any part unless it was thoroughly insulated from the others—and there is none such.

"But suppose they were all charged with *the same* electricity; then there would be repulsion between the balance and the adjacent parts." A charge of electricity exists only on the *outer surface* of the charged body. We might hang our watch directly on the prime conductor of a frictional electric machine and charge it to a potential of 50,000 volts, yet *not a trace of electricity would be found in the movement*—the whole charge would be on the *outside of the case* and the interior would be unaffected. Even if we could, by some special apparatus, contrive to touch the machine to some point in the center of the movement, the electricity would instantly pass through the watch plate to the outside of the case and remain there as before. If the case was not insulated or was "grounded" it could not be charged at all, as the electricity would escape through the connections as fast as it reached the case. But whether the case was charged or grounded would make no difference with the movement.

We might possibly contrive to send a high potential *spark* through a movement in such a way as to burn the hair spring, but that could not occur while the watch was being worn, except by having a stroke of lightning pass through it.

2. *Heating by electric currents.* "An electric current might heat a watch by flowing through it, and so affect it." Only strong currents would produce any perceptible heating, and such a current is not likely to be flowing through a watch when in the pocket. Even if it did, the most of it would flow through the case, on account of that containing the greatest mass of metal. A part might flow through the main plate of the movement. As we have seen, when there are several paths for the current, it flows through each in proportion to its relative conductivity. Let us suppose that one path was through the balance and hairspring, those being the only parts that could be injuriously affected by the small amount of heating which could be produced in that way. The amount of current which could flow through this path would be infinitesimal, because of its enormous "resistance," as we will see by tracing out the course it would have to take to make a complete circuit.

The jewels and oil are non-conductors, so the current will not flow

by way of any jeweled pivot. It would have to first enter the balance cock, to the hair spring stud, through the whole length of the spring to the collet, balance staff and roller table, *not passing through the balance at all.* Here the circuit is broken or open, and no current can pass except when the lever fork touches the roller table, metal against metal. If this occurs *at the same time* that the escape wheel tooth touches *the metal* of the lever pallets, current will flow to the escape wheel. If the tooth rests on the pallet jewel no current flows. From the escape wheel it flows to its pinion, through the fourth wheel and pinion, third wheel and pinion, center wheel and pinion, to the center wheel cap and plate. Compare the length and tenuity of this path, with its numerous poor contacts, when there is any path at all, (which can only happen occasionally through a combination of very poor workmanship and accidental contact of the lever with the roller table), with the relatively enormous bulk and short length of the other paths through the plate and the case, and it will be seen how small a share of the current could possibly pass this way, and how unfounded are any fears of trouble from this cause. The heat from the wearer's body would be a thousand times as great.

The reader should note the difference between a "charge" of electricity and an electric current. The former is "static" or electricity at rest, and is found exclusively on the outer surface of the *electrified body*, but an electric current flows through the entire mass of the *conductor*, and the greater its size the better conductor it is.

3. *Attraction and repulsion between adjacent conductors.* If we could suppose a current flowing around the rim of the balance, and another circular current flowing in the plate below and close to it, the motion of the balance might be affected by the latter if the currents were very strong. But very delicate apparatus is required to demonstrate even the existence of such attraction between currents, and the actual presence of strong currents, or of any currents at all, in the manner described, is evidently something which could not happen in a watch.

4. *Currents produced by motion in a magnetic field.* "A balance vibrating in a magnetic field would have a current produced in it and in the hair spring." Answer: A metallic circuit properly moved through magnetic lines of force will have a current produced in it. An example of this is seen in a "dynamo," where a current is produced by revolving the armature wires between the poles of the magnet of the machine. The pressure of the current is proportional to the speed with which the wires are moved through the magnetic field. But no current is produced unless there is a complete circle or "closed circuit," for the current to flow through, as before explained.

In a watch no current could be produced in the hair spring, because there is no complete circuit for it, and it moves too slowly. The balance is the only part which moves fast enough to possibly produce a current in this way. If we suppose it to vibrate while exposed to a very powerful magnet, a current might be produced under certain circumstances. For instance, if one pole of the magnet *M*, fig. 10, be placed above the balance and the other pole of like size below it, the lines of force would pass from pole to pole through the balance and parallel with the balance staff.

No matter how fast the balance vibrates no current will be produced in the rim, because the motion does not change its magnetic condition. But when the center bar swings through the lines of force a current would flow through it from the center *x* to each end of it (or the reverse way), *provided* it could find some path back to the center again to complete its circuit. Otherwise no current would be produced at all. We could fix a spring to rub on the rim and another on the staff, with a *stationary* wire to conduct the current from the former to the latter and thus provide a path; but such a device never existed in a watch, and obviously would not be permissible.

Next let us suppose that the magnet poles are small, as shown by the dotted circle *M* in figs. 11 and 12, and the magnetism is localized or confined to the space between them, *i. e.*, only one-half of the

center bar is exposed at a time to the magnetism. The current will be from 1 to 2, as before. If the rim is entire, as in fig. 11, the current divides at 2, flows each way around the rim to 4, then down to 1. In a cut balance, as in fig. 12, no such flow could occur, because the circuit is open at 3 on one side and at 5 on the other; therefore

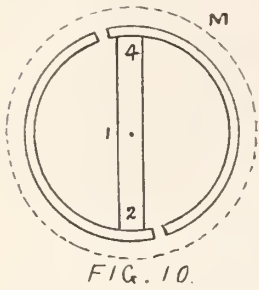

FIG. 10.

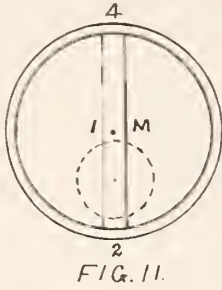

FIG. 11.

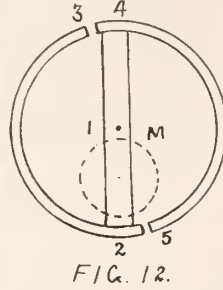

FIG. 12.

no current could be produced. Even in the uncut balance, while we may say that theoretically there would be a current, practically it would be too small to be measured and its effects would be hardly worth talking about—even if such an arrangement of magnet poles should ever be applied to a watch, which is highly improbable. With any other arrangement the effects would be still less. This effectually disposes of the idea that the motion of the balance when exposed to magnetism would produce currents in it which could injuriously affect the performance of the watch.

5. *Action of currents on magnetized bodies.* "A current flowing through a wire will deflect a magnetic needle held near it, and must, therefore, affect the motion of a magnetized balance." This effect is not due to any electrical attraction or repulsion, but to the magnetic action of the current, which produces a magnetic field around the wire in which it is flowing. The circular lines of force constituting such a magnetic field act upon magnets and magnetized bodies similarly to the lines of force of regular "magnets." The difference is that the latter are immensely more powerful. But the effect of the former is by no means to be disregarded, especially if the current is strong. I have seen a 6-inch galvanometer needle, pivoted on a point at its center, swung around several inches by the action of a 1,000-volt current, although the nearest point of the wire was fully 8 feet from the needle. Had the same wire, instead of being straight, been wound into the coil of a magnet and the magnet pole pointed at the needle, the effect would have been many times greater and could have been felt much further away.

The current mentioned had a volume of 1 ampère, which at 1,000 volts pressure, would give $1 \times 1,000 = 1,000$ watts, as before explained. As 746 watts are 1 electrical horse power, the current had nearly $1\frac{1}{2}$ horse power of energy, and might fairly be called a strong current. It is not extraordinary, however, for the mains or "leads" for electric light lines, and wires to motors, etc., may carry 10, 20 or 100 horse power, or even more. Compared with these, the currents used by jewelers, from a few cells of battery, are very weak. It would require at least 1,500 jars of the ordinary Daniels or "gravity" battery to furnish a working current of 1 horse power. But even the weakest current may be objectionable in a watchmaker's shop, and in another article I will describe how to nullify its effects and prevent any harm from it.

(To be Continued.)

The Ring Suspension of Chronometers.

AN INTERROGATOR in an exchange desires to be informed as to the age, etc., of the gymbals or chronometer ring suspension. As is well known, this sort of suspension is called in nautical phraseology the gymbals—a universal joint on which marine compasses or chronometers are mounted. Its object is to keep the chronometer itself level when the wooden chronometer box is constantly tilted by

the motion of the ship. On the continent it is called the Cardan or Cardano suspension, for its reputed inventor. It is obvious that so simple a thing should have been known a long time. The earliest historical account which explicitly speaks of the gymbals, and for sake of clearness gives a sketch of it, is contained in the sketch books of the architect Wilars de Honcourt, who lived in the 13th century. A fac simile of the book, which is preserved in Paris, was issued in Paris in 1858, with notes by Lassus. Wilars de Honcourt sketches no less than eight inter-connected rings, the central one of which serves for the reception of a brazier (*chaufferette*, Fr., *calfactorium*, Latin, *brazero*, It.) He says at the end of the description: "It is excellent for a bishop, who may without further trouble assist in a holy mass, and by keeping this contrivance in his hand they will remain warm as long as the fire in the brazier remains in glow. Farther explanations are unnecessary."

Lathes and Lathe Work.

BY THE MODEL WATCHMAKER.



BEVEL WHEELS and wheels which have teeth cut on the end like the change wheel to Swiss stem wind watches will need a change in our arrangement, and we will have to make another slide and also another arbor on which the wheels to be cut are placed. The first thing we will do is to change the slide which holds the wheels, and instead of having screws at each end of the arbor on which the wheel is placed we have only one screw. To thoroughly understand the change we will have to look back to the December, '88, number of this journal, at the slide shown in fig. 3. We change the lug *h* there shown as follows: Instead of having the screw *j*, we let the arbor extend through the lug *h* as shown at fig. 1 of the present issue. At fig. 2 is shown the form of the new arbor. It is made of steel wire about $\frac{1}{4}$ of an inch in diameter and $1\frac{3}{4}$ inches long. It has a conical shoulder where the front bearing *h* goes. Let us first understand what is required and then we can see the sense and object of the several parts of the machine. Bevel wheels for all modern watches are confined to the stem winding mechanism and the cutting machine or engine to produce such wheels must be able to cut teeth at any angle to the axis of the wheel. In strict sense, no bevel wheel to act correctly can be cut with a rotary cutter; teeth of this kind should be planed into form. Some of our advance machinists have already adopted this plan, and machines are in existence which will plane immense teeth to correct mathematical figure. Since I have so far digressed as to speak of the teeth of wheels, it may be well to add that watchmakers have, as a rule, neglected to post themselves in regard to the proper form for the teeth of wheels. Some of the earlier manufacturers of watches among the English makers looked to this and posted themselves on the proper form for the teeth of wheels, and the trains of the finer kinds of English watches produced fifty or seventy-five years ago are splendid specimens of epicycloidal teeth. The Swiss have also produced good work and the Ingold system of final rounding up of teeth gave excellent practical results. The greatest troubles experienced in the various systems of making watch trains lay in producing pinion leaves of the correct form, and preserving this form during the process of polishing. The epicycloidal form of tooth was universally adopted, as it allowed of making pinions theoretically correct in form and of a few number of leaves, and consequently coarse teeth in the wheels and allowing for more dirt space to enable

a man to carry a watch a longer time without cleaning, when the true policy would have been to insist on the casemaker doing his work more perfectly and furnishing a case which preserve and protect the movement from dirt. The Swiss and Americans adopted the plan of finer teeth and a larger number of leaves in the pinions, a plan the English were not slow to follow. This policy in connection with patent dust bands and dust-proof cases has made a great change. There is no doubt but epicycloidal teeth are very perfect in form, but they are difficult to realize in metal. We have a comparatively new form of teeth known as the involute gear of which we see specimens in the newer stem wind wheels of American watches, which have all the advantage of form of the epicycloidal and are much stronger. I do not suppose one of my readers in a hundred knows how to draw an epicycloidal tooth, yet they have frequently seen in the trade journals diagrams of these curves, but when it came to reading up the matter so as to understand it sufficiently to delineate a tooth of this kind they had not the courage. And still it is a necessary part of a horological education to be able to draw the correct form of teeth for wheels both of the epicycloidal and involute form. One trouble has been those persons who undertook the task of writing about such things in trade journals but very imperfectly understood the nature themselves, and consequently were unable to strip the problem of a great deal of useless rubbish. The writer purposes subsequently to take up this subject and write it up in a manner adapted to the wants and tastes of the practical workman. To resume our cutting machine: This plan of cutting engine will cut a wheel as well as any in existence and it will pay us to take some pains in making it; consequently if some of the parts look a little troublesome to make, the satisfaction of knowing that we will have a serviceable tool when we are done will stimulate us on to doing it. The lug *h*, fig. 1, in the present case will have to be sawn through the hole in *h*, where the bearing *j* of the arbor *A* goes as shown in diagram *h**, which is a view of fig. 1 seen in the direction of the arrow *f*. In the end of the arbor *A* is drilled and tapped a hole to receive sub-chucks like a wax chuck to a lathe. The end of the arbor *A* is shown enlarged in diagram *A**, and one of the small screw sub-chucks at *B*, diagram *A***. The sub-chuck *B* is threaded at *d* and goes into the hollow screw *d*, diagram *A**. The end *e* of *B* is turned to fit the hole in any wheel we have to cut. When we have a small shifting wheel, such as is on the square of the winding arbor of a Swiss stem wind watch, we get out our wheel and drill a hole

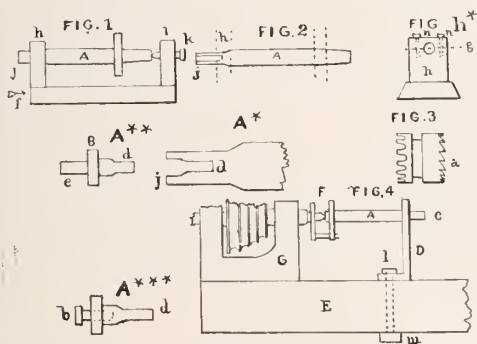

through it, so when squared out it will fit the arbor of the stem wind, and to fit the round hole in our wheel we turn the arbor *e*. I am speaking now of one of those little wheels which have teeth on each end as shown at fig. 3. If we choose to do so we could square the hole before we cut the teeth, and the round arbor *e* would still fit. It is better to turn off the outside of all wheels after they are on the arbor *B*. The wheels are soft soldered on the arbor *e* while they are being cut; this is more necessary in wheels like the one shown at fig. 3 than if they were flat wheels like those used in most American watches. For all flat wheels they can be secured by a steel screw *b*, as shown at diagram *A****. But such wheels as shown in fig. 3 and the one which engages the ratchet teeth at *a*, soft solder makes the most convenient fastening. The best method for holding the arbor *A* when turning sub-chucks *B* is to fit them to *A* as near as we can,

and then put the arbor *A* into a back rest and turn off chuck or wheel to suit; such a back rest is shown at *D*, fig. 4. This cut shows an American lathe head at *G*, the bed of the lathe at *E*, and the usual dog for turning with two cutters at *F*. The back rest *D* is made by bending a piece of No. 10 sheet brass $1\frac{1}{4}$ inches wide and 4 inches long as shown, when a hole is made for the arbor *A* in line with the lathe spindle. The back rest *D* is held in place by a screw *l*, which goes through the lathe bed *E* to the nut *m*. When the lug *h* is split and the top or cover *h* is held in place by the screws *u u*, a wheel much larger than the arbor *A* can be put in place without removing the wheel.

Problems in the Detached Lever Escapement.

BY DETENT.



IT IS NOT uncommon for workmen to receive a job of a new fork for a fine Swiss movement; probably one which will come somewhere near matching can be had if the workman is located in some large city, but this is not always the case; frequently we are compelled to make one; at any rate, it is well to know how to do such a job. We take a piece of soft sheet steel thick enough to form the thickest part of the fork. Before we commence to shape the thing, we need a steady, firm pair of dividers.

Those which are usually found on a watchmaker's bench being too springy, and usually another fault, which is, the points are imperfect; consequently, we will make a pair for ourselves, free from these defects. At all large hardware houses flat steel is now to be had $\frac{1}{4}$ of an inch wide and $\frac{1}{8}$ of an inch thick, and from such steel we cut out two pieces shaped as shown at *A*, fig. 1; also at diagram *A**. In the end of each, at *a*, drill a hole which will take a No. 2 sewing needle; then drill and tap for a set screw at *b*. The end of the compass where the needle goes can be filed away on the inner side almost into the hole, so as to let the needle points come as close together as possible. If the points are properly fitted such a pair of dividers will sweep a circle $\frac{1}{16}$ of an inch in diameter, and make a clean, neat line. The pieces *A* are two inches long, and are shown of the exact size and shape in the cut. A third piece is shown at *B*, fig. 2. This is also of steel and can be made from the kind used for the other pieces, or it can be made from $\frac{1}{8}$ square steel. The lower end of the piece *B* is flattened to $\frac{1}{16}$ of an inch from the cross pieces *C* down to the end *d*. The cross pieces *C* are made of steel and should be about $\frac{1}{32}$ of an inch thick when finished. They are attached to *B* with two rivets, and in the ends are drilled holes to receive the pins which form the joints *e e* for the two legs of the dividers. On each side of *B* is a spring, *g g*; these springs are rivetted to *B* at *h h*, and, when the dividers are together, serve to hold the divider legs drawn in toward the bar *B*. At diagram *g** is shown one of the springs, *g*, with a slot at *u*; this slot goes under the head of a screw at *u*, fig. 1. The screws *f f* are of tempered steel and each about $\frac{1}{2}$ an inch long under the head. About a No. 3 hole in a Swiss screw plate cuts the right size for these screws. The heads should be about $\frac{1}{4}$ of an inch in diameter, and milled on the edge. The set screws *b b* are better to turn with a screw driver. Diagram *C* shows a top view of fig. 2, seen in the direction of the arrow *i*. The upper end of *B* can have a little ivory handle fitted. The legs *A*, after they are fitted, should be hardened and tempered, and also the piece *B* with the chuck pieces *C*. The points *a a* should be about as hard as a drill, and can readily be sharpened by putting in

a split chuck and stoning the point with an oil stone slip. Such a pair of dividers readily open to $\frac{3}{4}$ of an inch and will sweep a circle on metal without flinching. We are now ready to go on with our fork. We will assume the fork to be for the so-called straight-line variety. We set our dividers to the distance from the hole where the pallet staff goes to the end of the guard point. With this space in our dividers we can tell where to drill the hole for the pallet staff. At fig. 3 is shown a complete fork, and in fig. 4 the piece (D) of sheet steel for the new fork. We determine about where the hole

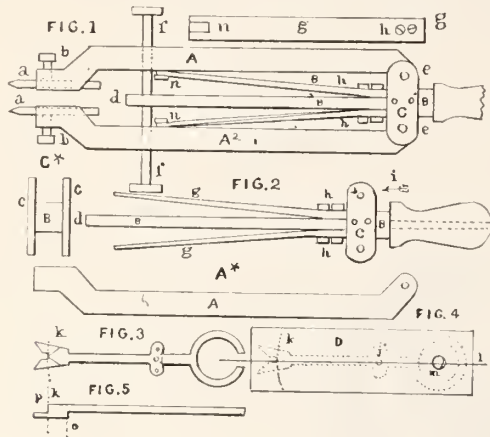

for the staff comes, and drill a hole for it at *J*, fig. 4. Then with our dividers sweep the arc *K*, which tells us where the end of the guard point comes. We draw the line *L* and proceed to outline our fork as shown at the dotted lines. Then with a graver follow the lines so as to give ourselves a firm outline to go by. We drill a hole at *m* and broach it out until the right size, bearing in mind the edge of the fork is to be ultimately beveled. This beveling is best done with a countersink at this stage of the process. The rough shaping can best be done with a jeweler's fine saw, leaving plenty of metal for strength to stand filing. After the fork is roughed out, it is lain flat on a block with a brass pin through the tail *m* to steady it. When filing, the whole fork is reduced in thickness back of the line *o*, as shown in fig. 5, which is an edge view of the fork. The hole where the pallet staff goes should now be tapped out to fit the screw on the pallet staff. The holes for the steady pins are to be left until after the fork is hardened. The drop for the fork at *P* is now filed and the fork proper shaped. Our fork is now ready to be hardened. A piece of thin sheet iron about one inch square is taken and folded together like the covers of a book and the fork placed in the fold, filling the fold with sal tartar (*carbonate of potash*), wetting the sal tartar with a little water. Place the iron and fork on a bit of charcoal, and with a blowpipe heat the iron and fork red hot and drop into water. It will come out clear and white, and quite free of scale. It is now to be tempered by placing it in an old iron spoon (from which the tinning has been removed by burning) with a lump of beeswax as large as a pea; the spoon is next heated over a lamp until the wax catches fire and burns off. The fork is now to be filed into perfect shape and finished. One point in such work is important, which is, to not attempt it with old, worn-out files. For filing the fork and guard point, a pair of cutting pliers holds the fork for filing the guard point as well as anything; if it does mark the work it will all finish out. To hold the straight part, a pair of little spring jaws which goes into any bench vise is the thing; a snap gauge to be used to get the sizes to correspond to the old fork. The beveled edges are only made after the fork is shaped. We cut the guard point to the proper length, only we let it be a trifle long to be on the safe side. The edges are stoned with an Arkansas stone slip to smooth them. The last thing before the final finish and polishing is to put the fork and the pallets together and try them in the watch, screwing the pallet staff firm and testing the lock and escape on each pallet; after these are all right we take out the fork and pallets and drill for the steady pin holes through the holes already in the pallets, using a drill which closely fits the holes. After the holes are drilled

take the fork and pallets apart and bevel the edges of the fork with a fine file, and then stone out the file marks and polish the beveled edges; this can mostly be done with a small burnish, following the burnish with a piece of pegwood and diamantine with alcohol. We next grind the top surface of the fork on a ground glass slab with oil-stone dust and oil until all scratches and marks are removed. We next go over the polished bevels again to restore their polish, and then put the flat polish on the fork on a tin lap with diamantine and alcohol. The fork and pallets are again put together and the final fitting given to the guard point and the slot of the fork.

New Nippers.

A NEW pair of nippers comes to us from Switzerland, and was shown in a cut by the *Journal Suisse d'Horlogerie* some time ago. The nippers have a peculiar leverage, and, apparently, the operator is able to exert an extraordinary degree of pressure upon them. As will be seen from the accompanying cut, the levers *B C* and *B D* are controlled by means of the other two very short levers, *E C* and *E D*, and the jaws of the nippers are opened by opening proportionally very long arms. When closing the arms again, the short levers, *E C* and *E D*, operate in an opposite direction upon the long levers, *B C* and *B D* and thereby effect, according to the law of levers, only a very slow penetration of the jaws. By consid-

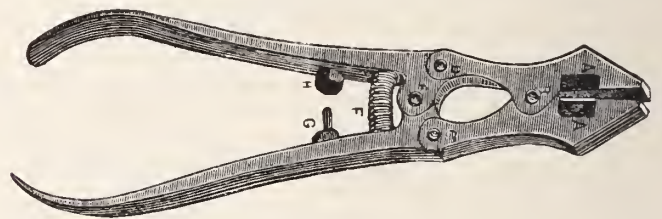

ering that the force produced thereby stands in an inverse ratio to the path described, it results that a very large increase of the work produced is obtained in this manner. This device has, besides this, the further advantage that the force exerted upon the object to be held or cut increases in the ratio as the jaws close, which is of advantage, especially in the cutting of wire, etc., since the nippers really exert the larger force when the cutting edges of the jaws have already penetrated into the article to be cut.

To prevent the coming in contact of the cutting edges of the jaws, so that they cannot become dull or gapped, one of the arms is provided with a pivot, *G*, which, in closing, braces against the knob *H* upon the other arm.

These nippers may assume a variety of forms, according to the purposes for which they are wanted. They may have flat jaws, simply for gripping, as shown in the cut; or bent jaws, provided with cutting edges, for nipping off wire, etc., or shear blades, to be used for cutting sheet metal, etc.

Resistance—"Intensity" of Current.

THE TOTAL resistance in the circuit is usually divided into *internal*, or that in the battery itself, and *external*, or that in the connecting wires and other portions of the circuit outside the battery. If the external resistance is much less than that of one cell, as when the poles of a single voltaic cell are connected by a short and thick copper wire, any addition to the number of cells in the battery will produce no perceptible increase of current, because by that addition we augment the internal resistance as fast as we increase the electro-motive power. But if the external resistance is much greater than the resistance in the battery, any addition to the number of cells will produce a nearly proportionate increase in the quantity or strength of the current, because we then increase the electro-motive force

much faster than we augment the total amount of resistance.

A current which is but little diminished in amount by the introduction of a given external resistance is, in common language, said to possess great "intensity;" but the difference of effect produced by means of a current from one cell and that from many, does not arise from any real difference in the nature of the currents in the two cases, but from the difference of proportion of external to internal resistance. No difference has hitherto been recognized in any two currents of equal quantity per minute, obtained from different voltaic sources.

The Parts of the Lever Escapement and their Functions.



THE DETACHED lever escapement comprises the following pieces, which have the technical names of: escape wheels, pallets (two), lever, roller, and balance.

The escape wheel of an English lever is usually made of brass, while in that of the Continent it is of steel; in the former it has sloping, ratchet teeth, in the latter, club teeth; confining our remarks to the English lever, the sloping teeth are for the purpose of aiding in the minute draught of the pallets and lever inward to the escape wheel at the instant when the roller and balance become detached from

the rest of the mechanism of the watch.

The two pallets and the body of the pallets are shaped out of a solid piece of steel, the parts having jewels set in them for the escape wheel to work on.

The lever is a poised piece of steel, having a notch cut in one end of it for action; the steel is hardened and tempered to a blue color, and afterward polished. The fashion of the lever varies according to taste, the mechanical advantage being the length from the axis to the notch.

The roller is a circular piece of steel, having a pin made of stone, fixed perpendicularly in it; the steel is hardened and tempered to a blue color, and afterward polished. The radius of the roller from the center to the stone pin, answers to a crank or handle of a wheel, the wheel being the balance.

There is also a little brass pin, fixed perpendicularly in the lever, named the guard pin, and a small, crescent-shaped hollow is formed in the edge of the roller, right in front of the jewel pin of the roller. The entrance of the little brass pin into the roller hollow constitutes guard pin depth.

Perpendicularly fixed in the frame plate of the watch are two small brass pins, named banking pins, one of them on each side of the lever; or sometimes a circular hole is made in the tail of the lever, and only one pin is fixed central in the ring. The use of these banking pins is to limit the motion of the lever after the escape wheel drops on the pallet locking, because otherwise the lever would move around a considerable distance, so as to run out of action.

All the escapement pieces are placed on three axes, made of blue tempered steel, and the polished, fine pivots being made at both ends of each axis, to work in the jewel holes. Sometimes, for the sake of cheapness, only one or two pairs of holes are jeweled, the pivots of the other axes working in brass holes.

The escape wheel is placed on the first axis, the body of this axis being a pinion, named the escape pinion; this pinion works in the last wheel of the train, and thus corrects the escapement with the train wheels; the last wheel of the train is named the fourth wheel, and upon the axis of this fourth wheel the seconds hand is placed.

The pallets and lever are fastened close together on the second axis, the body of this axis being made quite plain; and the roller

and balance are placed at a certain distance apart on the third axis; the body of this axis has a collet plugged on it, upon which the balance is fastened. Sometimes, to obtain unquestionable soundness, the axis and collet is made out of a solid piece of steel, named solid staffs.

The mode of connecting the balance and roller with the lever and pallets is by planting the pieces sufficiently close together, so that the stone pin of the roller is linked into the lever notch, by which contrivance the lever and roller can turn each other alternately, as will be shown, first remarking, however, that the vibration of a watch balance is a reciprocating circular motion, the motion being reciprocated by a spiral spring, usually called the balance spring, one end of which being fastened to the collet placed on the balance axis, and the other end to a stud.

Each of the two pallets is shaped for the double purpose of impulse and locking; by turning the escape wheel forward, a tooth of the wheel passes over one of the impulse planes, and thereby turns the pallets and lever together through a small arc, of perhaps about 9° ; and, as the roller and balance are linked to the lever by the pin and notch, the balance also is simultaneously turned through an arc, the balance arc always being much greater than that of the lever, according to the ratio existing between the radii of the small roller and longer lever. At the extreme end of the pallet plane, the impulse ceases, and another tooth of the escape wheel drops on to one of the opposite lockings, stopping all the machinery of the watch, except the balance and roller, for, at the instant of the drop of the escape wheel, the roller jewel pin passes out of, or away from, the open notch of the lever, and the balance and roller revolve by themselves, perfectly detached from the rest of the mechanism of the watch.

The force of the balance mass in revolving winds up the reciprocating spring, and as soon as this spring has secreted all the force of the balance, the motion is reciprocated by the uncoiling of the spring. Arrived at the place of the escapement arc (where the lever is lying at the proper angle against one of the banking pins), the roller jewel pin enters the lever notch, and the reciprocated force of the balance, by the aid of the roller pin, now moves around the lever and pallets sufficiently far to draw the locking out from under the escape wheel tooth, and, all the mechanism being then set free, the escape wheel moves forward again over the impulse plane of the opposite pallet, giving another impulse to the pieces, and again another tooth of the wheel drops on to the opposite locking, the wheel resting there and stopping all the machinery, while the roller and balance vibrate freely as before.

The foregoing is a description of the constituent pieces and action of this escapement, but it is still to be explained that the complete or full vibration of the balance is a motion produced by several additions of the impulsive force, the excursion of the balance emanating from the first impulse frequently being about 120° by measure on the balance circle, while the vibration at the end of the additional impulse is perhaps 200° ; this doubled for both sides of vibration makes 400° altogether, so that the impulses, as we see them at the full vibration, are given when the balance is already in motion, and no mechanical power ever operates with its full energy when the impelled body is already in motion, and in this case the force of pressure of the escape wheel and lever gradually decreases, as the balance crank or roller recedes faster from these impulse agents. It is only at the first impulse that the energy of the main power is fully effective in impelling the balance; all the after impulses gradually decrease in intensity up to the full vibration.

REFUSE TO SELL.—On account of the inferior grade of gold of the watch cases, twenty watchmakers of Basle have established a scale for the different sorts of watches, and have resolved not to sell below this scale: defaulting members to pay a fine of 500 francs. They have also established a price list for repairs.

A Few Points in the Adjustment of Anchor Watches.



ALTHOUGH capable of close timing, yet it is sometimes quite difficult to adjust an anchor watch in the different positions. The following are a few of the difficulties:

The characteristic of this escapement is its fork, which is solidly united with the anchor. At its other end the fork is provided with a prolongation for establishing a counterpoise; nevertheless, it may be observed in many watches that, in spite of this provision attached to the fork, this body is far from being perfectly and evenly balanced upon its axis. As may be supposed, this absence of equipoise prevents the adjustment in the horizontal and vertical positions, and before the adjuster expends any work it is necessary to place anchor and fork into the poising tool, and to establish the equipoise in a suitable manner, in case it does not already.

Next are those errors caused by the watch being placed in certain positions, such as a slight scraping of the guard pin in the guard hollow, or the ruby pin within the horns of the fork, or upon the bottom of the notch of the fork. Defects of this kind are easily discovered by the ear; any strange noise is suspicious, and any one accustomed to the free, sharp ring of an anchor watch will detect at once any scraping sound in it and discover the cause.

Examine the motion of the balance with an attentive eye. A balance which does not run truly circular, the rim of which does not everywhere show the same breadth and thickness, or one in which steel and brass are unequally divided, is entirely unfit for close regulation. The writer, some time ago, saw an excellent balance, manufactured in Germany, which he considered very proper and useful. The timing screws were placed in longitudinally-cut holes in the balance rim. A delicate incision in the direction of length is made through the screw holes in such a manner that they have a slight springiness, which enables the screws to move very gently, without danger of becoming loose.

When withdrawing or inserting the quarter screws, it is not necessary to take the movement out of the case; simply hold the balance rim at the place where the screw to be operated on is placed, with a pair of tweezers, and make the alteration in such a manner as to exert no lateral pressure on the balance rim or staff pivots. Very delicate and sharply filed screwdrivers are necessary for this job.

The regulator performs an important function in timing. The writer has known many a young fellow-workman who tried vainly to reduce a watch to a regular rate, simply because he had not given sufficient attention to the regulator. It is well known that it should move with gentle friction—neither too hard nor too soft. Equally well known is the fact that the outer spring coil must lie exactly in the circle described by the curb pins. To some watchmakers, however, it appears very unimportant whether the curb pins stand far apart or closely together, yet this difference is productive of many irregularities in the rate of the watch. The curb pins must never squeeze the balance spring else it would be forced into an unnatural position with each displacement of the regulator. Equally objectionable is an undue width of these curb pins. Let us suppose them as being too wide, with the balance spring lying face between; it stands to reason that, with small vibrations, the entire length of the spring is in action, regardless of the presence of the regulator; the spring would then touch the curb pins only in more extended vibrations, and an acceleration would ensue. If, however, the regulator fork is too wide, and the spring is placed against one of the pins, it will not, in small vibrations, proceed from the pins, and approximately operate in such a manner as if its length only reached up to the pins. In its larger vibrations it will proceed from the pins, and the vibration will be retarded.

Watches that have been carelessly treated in this respect always show a great difference in their rate between the full winding of the mainspring and the draw of its last coils. If a close rate is demanded

the curb pin must be kept free from filth and oil, because a slight sticking of the spring at these parts is apt to create other irregularities.

It may be deduced from these remarks that the regulator fork should be left closed—so close, in fact, that only a barely perceptible motion of the spring may be observed between the pins.

The repairer should never bend the curb pins apart in order to retard the rate. This, of course, will produce the desired effect, but other errors are invited thereby, and the same end can be accomplished by safer and less objectionable methods.

Another pernicious habit of some watchmakers is to bend the curb pins in case they do not exactly correspond with the position of the balance spring, to suit the occasion. It is evident then that the pins will stand no longer at right angles, but obliquely, to the plane of the spring, and the faulty result occasioned by such irregular touching of the spring at each vibration can easily be imagined. If it is impossible to avoid this bending, then the pins should at least be brought back to a vertical position by being bent with an elbow. It is also advisable to the watchmaker to closely study the different systems of regulators used by the different manufacturers, because, for a close adjustment, it is of great importance to have even the smallest motions of the regulator under perfect control, and inventive talent has sought ways and means by which even the most minute deviations are controlled by the regulator.

Conical Pivots.



AN INTERROGATOR in the *Deutsche Uhrmacher-Zeitung* desires to know how best he can make a conical pivot, to which question two answers are returned. B. i. F. says:

I.—. . . For making a conical pivot I use the contrivance in the lathe shown in the accompanying figure, which is doubtless known to many watchmakers; it may perhaps suit the purposes of interrogator. Few words will explain its use. The lathe center to the left is provided with a disc, similar to that used for rounding off pivots, only much thicker. This disc, of which a front view is shown at *a*, is furnished with four funnel-shaped holes of different sizes. In order to make conical pivots on an arbor, it is furnished first with fairly tapering centers, and then mounted in the lathe, as shown in the cut. The center to which the conical pivot is to be turned must protrude by a little more than one length of pivot

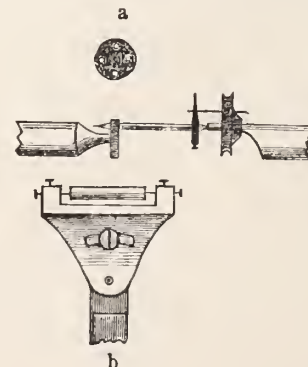

FIG. X.

through the disc. The pivot, standing free, is now worked with a proper graver, for which is suited best a graver with rounded-off edges, because the hollow on the pivot may with it be turned easily and nicely smooth. The pivot is next ground with an iron file and oilstone powder, and polished in the ordinary manner with the composition file and steel rouge. The grinding file, as well as the polishing file, must have rounded-off edges upon the right side, corresponding to the pivot hollow. In order to make the pivot nicely flat, it is necessary to rest both the grinding and polishing file upon a

roller running parallel with the arbor, for which purpose a device, *b*, is used, which is fastened in the lathe in place of the rest.

Another correspondent, H, says:

II.—Although the making of a conical pivot has been well explained in No. I., still it may not come amiss to describe more methods than one. Those below cannot be said to be new, but they are practical.

In order to make a good conical pivot, turn it first of a suitable length and exact conical form, but leave it a little thicker. Then make a notch upon a brass block of equal height with an eccentric counter-center. Let the pivot rest in this notch, analogous as by polishing in the burnishing tool, only that in the present instance the grinding file is used in place of the burnishing steel. Such a one is made of either square, soft iron or soft steel, giving it the required shape, something like accompanying cross-sections, fig. 1. Coarse redstuff may be used for grinding. When the pivot has been ground and cleaned, burnish it with the same file and fine rouge.

Many English makers of new work use, in place of the square grinding file, round steel or round iron of suitable thickness, which corresponds to the desired conical form, and make good pivots with it. The skilful workman has it in his power, by holding the grinding file—in case a trifling mistake in measuring should have to be corrected—to either lengthen or shorten the pivot a little, if necessary. When the pivot is polished well, give it the high, black luster peculiar to the English pivots and axes, by subsequently passing over it with a hard, highly-whetted burnishing steel.

Conical pivots may also be made upon the burnishing tool, without a special form being necessary. The pivot must also be turned first of suitable thickness and shape, so that it can still lose a little of its thickness. Then lay it only so far upon the suitable form of the burnishing tool as the cylindrical part is desired long, and polish it

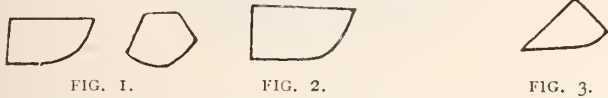

with the customary burnishing steel with rounded-off edge. There are pivot polishing files in commerce which are for this purpose provided with a cut on the rounded-off side. They are, however, unsuitable for fine work, and it is well for the watchmaker to make such a file himself. Round off the edge with an emery stone or an oil stone, so that it has about the shape shown in fig. 2, and sharpen the face of the file as well as its rounded part upon a copper or lead plate with oilstone powder. Many workmen prefer a three-cornered file, shown in fig. 3. But since a fine polish is to be produced with such a file, and it must cut at the same time, it is necessary to sharpen it frequently. Very passable—yes, good—pivots are produced with a burnishing steel in the rounding tool. Its cylindrical part, however, becomes a little longer than one made with the grinding file, and, therefore, it is suitable for Swiss watches the holes of which seldom have the requisite rounding, and always are thicker, better than the English conical pivot. This, on the other hand, is again better for English watches, with its carefully-made hole bushings and heavy balances.

Magical Clock.



AN ENGLISH inventor some time ago obtained an Imperial German patent for a so-called magical calendar clock, which has no visible movement, and which indicates the hours, days, and date upon the minute dial. The hand may be set forward or backward without influencing the rate of going of the timepiece; after this it returns automatically to the point indicating the number of minutes which have elapsed since the full hour. Readers of THE JEWELERS' CIRCULAR who desire to manufacture a quaint piece for their show windows have now an excellent opportunity or suggestion

for doing so, and we will therefore endeavor to describe it as fully as possible.

The timepiece consists of one hand which freely revolves around an axis, and is balanced by a counterweight which is actuated by a movement in the interior of the hand, in such a manner that the hand is forced by the constant change of the point of gravity to make one revolution per hour. Beside the counterweight, the movement also propels discs, containing the hours, the names of the week days, as well as the days of the month, all of which discs are also contained within the hand; the corresponding indications of these functions are shown through openings in the hand. The hand revolves best over a disc, which may be of glass, and transparent; it serves as the minute dial. Accompanying cuts show the invention:

Fig. 1 shows the front view of a disc; the hand standing at three-quarters (45 minutes).

Fig. 2 is a front view of the hand, with cover removed.

Fig. 3 is a longitudinal section of it.

Fig. 4 shows an enlarged view of the longitudinal section of the two parts of the hand, containing the train.

Fig. 5, finally, is a section for showing the manner in which the clock mechanism is fastened upon its center pivot. *A*, fig. 1, is a disc which, as previously said, may also be of glass and be transparent, which constitutes the minute dial. *B* is the hand, which revolves freely around its stationary axis. The hand consists of a

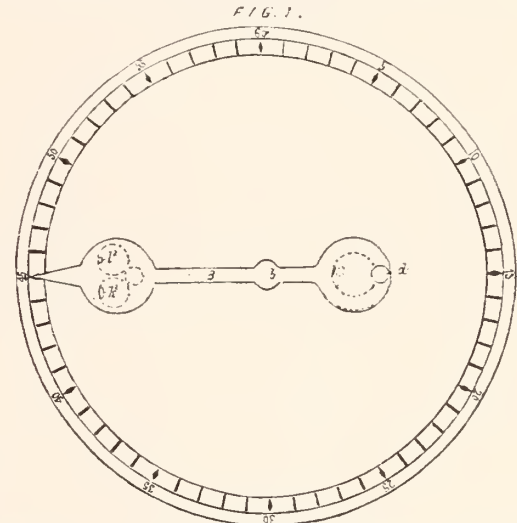

hollow case with a circular enlargement at its shortest part, which contains the clock movement *C* and one disc with the hour numbers. The longer or index part has a similar enlargement, which contains the discs with the names of the days of the week and of the month.

The movement *C* differs from an ordinary watch movement only by the fact that the motion work is independent from it, and that the movement itself revolves upon a central axis. This is produced by locating the center wheel *c* upon a center pivot *c'* (fig. 5), which is firmly united with the case of the hand, whereby the center wheel remains stationary, that is, upon one point. As the movement is free otherwise, the impulse proceeding from the mainspring causes the whole to revolve around the center wheel *c* (fig. 5).

To the movement is added a weight *E* (figs. 3 and 4), which in connection with it and the shorter arm of the hand keeps the longer arm of the latter in equipoise. The weight is revolved by the movement within the hand case, and causes (because the center of gravity of the whole hand in proportion to the axis *b*, figs. 1, 2 and 3, is shifted thereby), the hand to describe the circle upon the disc.

F (figs. 2 and 5) is an eccentric fastened upon the back of the capsula in which the movement is inclosed. This operates upon a push rod *G* (fig. 2), which slides within grooves, and is provided with a spring *H*, which is wound by the influence of the eccentric in its revolution within the movement. The hereby collected force of the spring *H* is used for the purpose of turning, at the completion of every hour, the hour disc one-twelfth of a revolution, and at the

lapse of each twenty-four hours, the disc for the week days and date, each in proportion to the designations which it carries. The hour disc *D* (figs. 2, 3, 4 and 5) is movable upon the pivot *c'*, and is actuated by an elastic click, which is fastened to the push rod *G*, and depths in a circle of twelve pins upon the back of the hour disc, whereby this is propelled forward tooth by tooth, so soon as the spring *H* of the push rod *G* is unlocked by its gliding from the projection of the eccentric. A spring *d'* (figs. 2, 3 and 4) serves for the purpose of completing and limiting the motion of the hour disc. A catch *g'* (figs. 2, 3 and 4) at the other end of the push rod *G* seizes in a wheel *I* with 24 teeth, which again has a tooth *i* that seizes into a circle of 7 teeth *k* upon the back of the disc *K*, carrying the days of the week, whereby this makes one-seventh of the revolution of a 24-hour revolution. The wheels *I* (fig. 2) has beside this a second tooth *l* which stands in connection with a 31-tooth disc wheel *L* (fig. 2), which carries a disc containing the days of the month, which, simultaneously with the motion of the disc *K*, receives a proportional part of a revolution.

The disc fastened on *L* can be set, in order to regulate the unequal number of the days of the different months. The wheels *I*, *K*, and *L* are all located upon firm center points in the enlargement

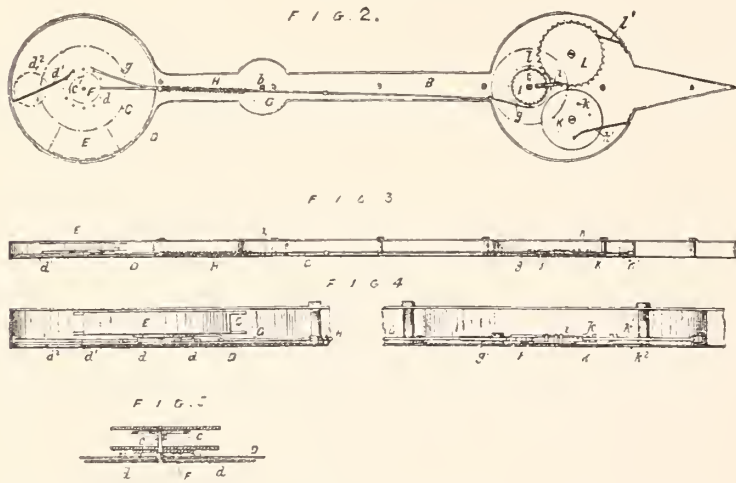

of the long or index part of the hand, and provided with clicks *k'* and *l'* (fig. 2) which limit its motion. The hour, week days and date signs upon the three different discs show themselves through openings *d*², *k*², and *l*² (figs 1 and 4) in the case of the hand.

To sum up the above detailed description, this so-called magical calendar timepiece consists essentially of a hand *B*, loosely mounted upon a center, which carries at its shorter end a rotating movement, made heavy by a small weight, which revolves once each hour around the minute circle of the dial. As the movement is beside this provided upon the back with an eccentric, *F*, which operates upon a push rod, *G*, and spring, *H*, this arrangement also actuates simultaneously in the intervals described in the preceding the hour circle *D* in the shorter end of the hand, as well as the discs *K* and *L*, contained in the long arm of the hand, since, furthermore, these discs carry circles with the hours, days and months, these different chronological events appear at regular intervals behind the opening in the cover of the hand.

LUBRICANT IN TURNING.—The choice of a lubricant in turning is of the greatest importance. In my experience I have found carbolic acid to be by far the best. I always could drill the hardest pinions and arbors when using it. It has no effect upon the metal used in horology, and possesses the characteristic of largely increasing, by its caustic action, the action of metals to each other. On account of this peculiarity, it is with advantage used in sawing, cutting and grinding.

The Marfels Watch Collection.

[From the *Deutsche Uhrmacher-Zeitung*.]

Continued from page 73, April, 1889



LSO, the artistic embellishment of the case of the large watch shown in fig. 46 is such as is but rarely met with. The ornamentations in this piece are not chased but engraved, and the richly engraved designs of animals and arabesques even run around the rim and cover the bezel, which largely enhance the value of the watch in the eyes of lovers of art, as this style of ornamenting a case presupposes a great amount of skill and taste. The case is of bronze, and incloses one of the high French movements such as were made at the commencement of the XVIIIth century (the watch was made about the year 1710), and which are even much higher than the



FIG. 46.

English movements. The excellently executed movement (with one hand only) possesses a nice balance bridge. The dial also is bronze-gilt, while the hours are painted upon specially inserted enameled plates. The maker is Clement Fiacre, Paris.

The peculiar, striking ornamentations upon the case of the next watch are also neither chased nor pressed, but engraved and *ciselé*. The ornaments, consisting of flowers and foliage, are bas-relief; although simpler than those upon the previously described watch, they are stronger in execution, and are quite handsome upon the silver case. The watch made by L. Hess, of Zurich, dates to the com-



FIG. 47.

mencement of this century, and is therefore modern. The movement has nothing worthy of note—on the contrary it is of a simple style, similar to nearly all the watches of that period. While the pillars, dials, bridges, etc., of the French watches of the XIIth and beginning of the XIIIth century are sometimes worked with an

astonishing degree of taste and skill, those toward the end of the latter are distasteful and devoid of style. This, however, is entirely in accord with the insipidity of the style prevailing at that epoch.

Well-chased watches are, in general, quite rare, and good, well-preserved specimens embellished *à quatre couleurs* (in four colors) are still more so. The greater number of those of this kind were gotten up indifferently, or, if executed with a fair degree of skill, they have been disfigured almost beyond recognition by long-continued wear, in consequence of which they are of no value in the eye of the antiquarian.

The two specimens in the Marfels Collection are excellent in all



FIG. 48.

respects, and therefore form a valuable part. One of these watches is shown in fig. 48, while the other is shown in fig. 49. The former is a highly arched cylinder watch of the older style, and has upon the back part of the case remarkably well-chased gold overlays, representing a kind of still life. The name of the maker, Wilh. Bode, of Wilhelmsthal, is engraved upon the name plate of the movement. The watch was made about the year 1780. As is perhaps known to but few readers, the overlays of "four colors," in red, green, bluish white and yellow, in works of this kind, are all of gold; the different colors are produced by alloying the gold with silver, copper, etc.

A peculiar treatment of the case, such as we have not yet found



FIG. 49.

hitherto, is shown in fig. 49. The back bottom of this case is covered with a dark enamel through which wind lighter enamel arabesques, executed with great artistic taste, in different colors. These ornamentations represent a bouquet of flowers, upon which rocks a butterfly, producing a very agreeable effect upon the dark ground. This watch, the maker of which is unknown, was made about the same year as the last mentioned; its movement possesses no special merits. The dial is of silver, but is not by far made as exact as those of watches of the XVIIth and XVIIIth centuries which we have seen, for which reason we called them little works of art.

Of the watches with "piqué" over case, we have shown our read-

ers one in fig. 31, a fairly handsome production. A second excellent specimen of this kind is shown in fig. 50. As was already remarked at the first piece, this style of ornamentation consists in inserting into the tortoise shell case gold or silver pins or inlays in such a manner that occasionally highly tasteful groups and scenes are produced thereby. In the central piece of the case under review the arabesque-like ornamentations form a flower vase, while the other



FIG. 50.

part is embellished with garlands of foliage, upon which birds are rocking. These ornamentations, together with their harmonious groupings, are of a very charming effect upon the dark tortoise shell.

Peculiar to this watch is the dial, which is quite a departure from the usual routine of those ages. While the central part of the dial is enameled white, the hour ring is of silver. According to all appearance, the maker recognized the shortcoming of silver dials, which, although they were always engraved excellently well, did not show the hours readily perceptible by the hands used, and desiring to improve this defect, he chose the arrangement of enamel and silver, as, upon a dial arranged in this manner, the position of the hands is at once visible. The watch was made by C. Csacher, of Prague, about the year 1725.

We have had occasion heretofore to remark that among all the English watchmakers, C. Cabrier, of London, has produced most



FIG. 51.

excellent work in the execution of the fine and stylish bridges and dials. Another confirmation of the truth of this praise is given in a silver verge watch with double case, shown in fig. 51; its dial and balance bridge really stand unexcelled in its exact execution and combination. The case, also, of this specimen, of which, deplorably, only the external ornamentations are preserved intact, is most admirably chased and can worthily compete with the interior ornamentation of the case. In this piece are united (a thing which is but

rarely found) an excellent interior as well as exterior ornamentation. The mythological scene in the central part of the case, surrounded by admirable ornamentation, has suffered by wear. The interior case, as is commonly found, is smooth, and contains a well-preserved movement, the back plate of which bears the name of the maker. According to all appearance it was made in the first half of the XVIIIth century.

The following silver verge watch with double case pertains to the class of perforated and chased work; the interior case, however, is not smooth, similar to that described above, but perforated very artistically, like the exterior. In figs. 52 and 53 we give views of both cases. The very broad rim of the inner case is perforated, as



FIG. 52.

shown in fig. 52, the device consisting of handsome animal and foliage arabesques. The ornamentation of the central part of the outer case is a skilfully chased mythological scene, enveloped by charming ornamentations, which are perforated toward the rim. The bezel of the covering case also is provided with handsome ornamented work. The movement, of the English style of construction, also, is embellished by delicate engravings, especially the balance bridge. The maker of this work of art, dating to the middle of the last century, is Gottfr. Poy, of London.

Extremely interesting to the professional man is the cylinder



FIG. 53.

movement of the very oldest system, which is of a style of construction entirely departing from the customary arrangement of the parts. The escapement occupies precisely the center of the movement, and the other parts are arranged around it in a circle, so that this style might, with a certain show of reason, be called a "concentric." There are no bridges in the ordinary technical signification of the word; the pivots run rather in round steel hoops, which rest upon steel pillars. Generally speaking, this ingenious movement is made almost entirely of steel and embellished with differently-colored (damaskened) steel ornaments, which still heighten the attractive

piece of workmanship. The arrangement of the wheels and pinions is a very peculiar one; thus, for instance, the depthing of the fourth wheel into the scape wheel pinion is entirely invisible, and so also is the barrel under the dial. This highly interesting watch may have been made about 1780; its maker is not known.

Worthy of mention is a gentleman's watch, dating from the com-



FIG. 54.

mencement of this century. The dial is the distinguishing part; upon it are, besides the hour circle, two vases painted in enamel, which are at casual inspection not remarkable for anything; but on close inspection, the examiner will find that on each of them is painted a miniature picture of the smallest kind, representing country scenery; so small, indeed, that the examiner will ask himself how it was possible that the painter was able to crowd such a number of objects into so small a space. At any rate, the artist, who is unknown, must have possessed a degree of skill and patience such as is but rarely found at present; it need barely be mentioned that he must have used a magnifier. The pictures are so small and delicate that it could not be reproduced in woodcut.

Repairing and Polishing Marble Clock Cases.

L. CHOISY publishes in the *Union Horlogerie* a method of repairing and polishing injured marble cases, from which we translate the following:

It happens often that the marble case of a mantel clock is injured by accident or unskilfulness; its corners are generally the first to suffer. If the damage is not so great that there is no other way but to replace the old case by a new, the repairer may make the case a little smaller until the edges are reproduced, after which the polish is restored. Do as follows:

With a file take off from the damaged part as much as necessary, taking care, however, not to alter the original shape of the case. Then grind off the place worked with the file with a suitable piece of pumice stone and water, and continue the grinding next with a water stone until all the scratches have disappeared; special care, however, must be paid to the corners and contours. After this take a hard ball of linen, moisten it, and strew over it either tripoli or fine emery, and produce a polish by rubbing until a certain luster is produced. Finish polishing with another linen ball, using with it finely washed emery and rouge; dry and finish the polish with a mixture of beeswax and oil of turpentine. This method may be used for all sorts of marble.

In cases where the fractures are very deep, so that the object cannot be made much smaller without ruining the shape, the damaged parts may be filled with a cement, prepared with finely powdered marble and a little water glass. Stir this into a thick paste, which fill into the deep places and permit to dry; after drying correct the shape and polish as recommended for marble.

If the broken off or out pieces are on hand they may be glued in place again. Wet the pieces with an aqueous solution of silicate of potash, insert them into the fractured places and let dry for forty-eight hours.

For white marble, egg albumen with a little Vienna lime must be used.

In order to impart a high luster to whited marble objects which have become dim, it suffices to cover them with a fluid solution of oil of turpentine and virgin wax, and then to rub them dry with a linen or cotton cloth. A handsome luster is invariably produced by hard rubbing.

Jules Jürgensen

OF COPENHAGEN.

The reputation these watches have maintained for nearly fifty years has never been equalled.

SOLE AGENTS,

John E. Hyde's Sons,

No. 22 Maiden Lane.

ESTABLISHED 1853.



AMERICAN

AND

FRENCH CLOCKS

AND

BRONZES.

B. J. COOKE'S SONS,

137 N. 3d Street,

PHILADELPHIA.

Catalogues and Price Lists furnished to the Trade only, on application.

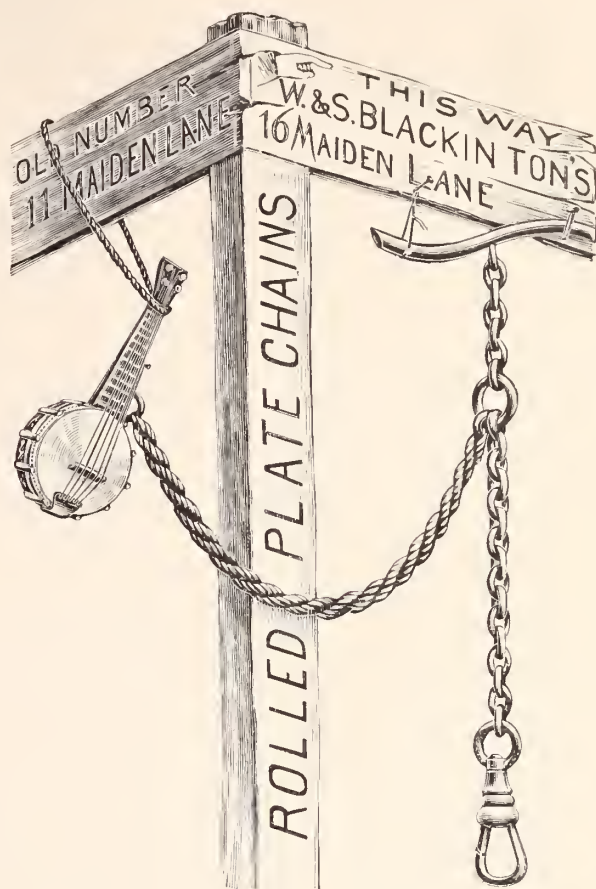

CLOCKS

THE NIAGARA FALLS

CHROMO PAPER BOXES

ARE THE MOST ATTRACTIVE PAPER BOXES EVER PRODUCED.

AS AN ADVERTISING MEDIUM THEY ARE UNSURPASSED.

The Boxes come in six sizes with a different point of interest on each box, which have been reproduced from original photographs of the six principal and most attractive points of this world-renowned natural wonder. They are produced in the natural colors of summer garb. Each box is wrapped with white paper held by a rubber band, with colored cotton enclosed ready for use. We have set the price for these boxes so low that every jeweler will see a benefit by using them as an advertising medium.

PRICE PER GROSS, (including Printing,) \$4.00.

On receipt of One Dollar we will send sample of five nests, free of postage to any address.

WIESBAUER M'F'G CO.,

MANUFACTURERS OF JEWELERS' FINDINGS, CASES, TRAYS, ETC., ETC.

BUFFALO, N. Y., U. S. A.



TO SOLDER METALS AT LOW TEMPERATURE.—According to *La Metallurgie*, an alloy useful when metals are to be soldered together at a low temperature can be made as follows: Copper in a fine state of division is obtained by precipitation with zinc from a solution of sulphate of copper. From 20 to 30 parts of this, according to the hardness required, are mixed in a cast iron or porcelain mortar with concentrated sulphuric acid, to which is finally added 70 parts of mercury, and the whole triturated with the pestle. The amalgam thus formed is thoroughly washed with water to remove the sulphuric acid, after which it is left untouched for from ten to twelve hours, at the end of which it is hard enough to scratch lead. To use the alloy for soldering it is warmed till it has about the consistency of wax, and in this state it is applied to the joint, to which it adheres very firmly on cooling.

GILDING IN THE MEDIEVAL AGE.—It is well known that the gilding of the early ages was in large part unsurpassable, and much of it stands unrivalled by modern works. How the old gilders did it, is recorded in an old manuscript (under date 1530) by a notable gilder, recently found in Mayence. Its title is "A few arts for preparing many kinds of inks and all kinds of colors." We copy a few: "Take honey slime, mix it with glue, write with it, let it dry somewhat, place the silver or gold upon it, and when entirely dry, polish; or, take menium, temper it with linseed oil, write with it as above explained; or, place gum arabic in vinegar until it becomes white, then take it out and place it in white-of-egg until it dissolves, write with it; when entirely dry lay the gold on, let stand over night, and then polish with the tooth."

THE USE OF BENZINE.—We frequently see benzine recommended for cleaning watches, and, frankly speaking, do not hesitate to recommend it. But it should be remembered that only the purest should be used, as the ordinary contains a number of hydrocarbons that do not evaporate readily, but remain on the metal, soak into it and combine with the oil subsequently applied, making it thick and gummy. Pure benzine should evaporate completely. If the slightest smell can be detected on a piece of brass dipped into it, after an exposure of one minute to the air of the room, it is entirely unfit to be used for a timepiece. It is always well to warm the articles cleaned in benzine to insure its complete evaporation, and afterward to thoroughly clean out the holes with soft pegwood.

CLUB-TOOTHED SCAPE TEETH.—A club-toothed escape wheel allows of a closer action than a ratchet tooth. Grossmann, in his essay, chapter 7, gives 3 degrees for drop with a ratchet tooth; but that is more than sufficient. If the wheel is a good one, with a fine tooth, 2 degrees are enough, and leaves $\frac{1}{2}$ degree of shake, though pallets are more often made with 3 degrees of drop than they are with 2 degrees.

FLATTENING AN ORDINARY BALANCE SPRING.—Remove the collet and stud, and clamp the spring by a central screw between two plates, which are then placed on a blueing tray and gently heated. A small piece of whitened steel is laid on the plate, in order to see that the heat does not exceed what is needed to give a blue temper. Allow the plates to cool and separate them. Ordinary springs, being made of rolled steel and subsequently coiled, always open out on heating; it is, therefore, necessary, before resorting to the above method, to coil up the spring, as otherwise the outer turn will be found to have opened beyond the stud.

TO PURIFY MERCURY.—Mercury often becomes contaminated with alloys and other impurities which may be removed by simple filtration. This may be done in glass funnels, the stems of which are

drawn out to a fine capillary tube. But this becomes often clogged after a short time, and then ceases to act; besides, it acts very slowly. Prof. C. Bohn, of Aschoffenburg, recommends a method which has long been practiced in Bunsen's laboratory. A filter is made of writing paper and numerous fine holes pricked into it. Instead of making these round with a needle, it is better to use the point of a penknife, which causes the little holes to be oblongly triangular. The holes should be pricked both vertically, in the direction of the radius of the filter, and horizontally, at right angles with the former, part of the holes should be pricked from the outside inwards, and the others in the opposite direction. Even with this arrangement, the filtration sometimes proceeds only very slowly, but it may be accelerated by using a filter-pump. A still better way to purify mercury by filtration, according to the same author, is the following: Select a glass tube, of about the thickness of a lead pencil, and about a yard long. Expand one end to the shape of a funnel and the other to a tulip-shaped bulb, or expand this end in a wave-like form, such as is customary when rubber tubing is to be stretched and tied over the end of a tube. A piece of linen or chamois is firmly tied over the latter end, and the tube then suspended. On pouring the mercury into the funnel, it will be pressed through the pores of the filtering medium with a pressure considerably exceeding that of the atmosphere.

THE UPRIGHTING TOOL.—This very useful tool, which is called by different names, such as uprighting tool, table tool, drilling tool, etc., should be found in every watchmaker's shop. A very good tool of this description is that constructed by Mr. Boley, of Esslingen, Germany, and may be described as follows: From the back of a table on which the work is laid an arm arises. This arm terminates in a long hole exactly over the center of and perpendicular to the table. A perfectly cylindrical arbor or runner passing through this hole carries at its lower end a pointed center or a drill, as may be required. At the top of the arm is a ferrule, so that the drill holder may be rotated for drilling. Two clips are provided for securing the work to the table. Two centering runners generally accompany this tool, one for putting through the hole in the arm and the other for passing through a corresponding hole in the table. The latter is handy in cases where it would be inconvenient or impracticable to upright from the top. Besides this, split chucks of different sizes for holding the drills belong to the tool. The chief requirements in an uprighting tool are that the holes in the arm and in the table shall be exactly opposite and straight with each other, and also perfectly perpendicular with the table. If the holes are in line, a true runner fitting them should pass from one to the other without binding. The readiest way of testing if the runners are perpendicular to the table is, first to ascertain that the runners are true in themselves, and then fasten to each of the runners in turn a piece of wire extending horizontally to nearly the edge of the table exactly the same distance all around, if the tool is correct. It is true that uprighting tools are not used as much as formerly, it having been proved by experience that accuracy of drilling is more absolutely insured if the work rotates, and the lathe is now generally preferred where extreme exactness is required. However, from the readiness with which the work may be adjusted in a table tool, it is not without its advantages.

SIMPLE TEST FOR GOLD.—Take a piece of flint and rub against it the metallic object to be tested, until the latter leaves a sufficiently marked trace upon the stone. Upon bringing the flame of a sulphur match in contact with the spot, the latter will remain intact if it has been made with gold, but will disappear if the contrary be the case.—*La Science en Famille*.

LUBRICATING SCAPE PIVOTS.—The scape pivots require very little oil, and in this particular watchmakers lubricate too copiously, especially the scape-wheel pivots. The oil will draw into the pinion, spread over into the fourth wheel, and, mixing with the constantly accumulating dirt and dust, quickly wear out the pinion, while the pivots run dry.



[FROM OUR SPECIAL CORRESPONDENT.]

IN THE WESTERN METROPOLIS.

CHICAGO, April 20, 1889.

There is little calculated to awaken enthusiasm in the condition of the Chicago jobbing jewelry trade of the past month. The retailers are doing a satisfactory business, but the jobbers are grumbling, and your observer, wishing that his remarks shall at all times be reliable, cannot truthfully concur in the reports appearing in other jewelry journals respecting the present state of trade. While it is always more agreeable to chronicle a condition of happiness and prosperity, it can do no good to mis-state existing facts. Chicago's jewelry jobbers are *not* over-rushed with business; trade is *not* equal in volume to the corresponding month of a year ago. While this is true, however, there is no occasion for uneasiness or alarm, or even much discontent; a fairly profitable business is being done, the collections are up to the mark, and, all in all, the trade is in a healthy condition.

When Stein & Ellbogen, known in Chicago as the "Twins," announced in January last their intention of retirement from business, THE CIRCULAR made the prophecy that they would change their minds; they have changed their minds, and their long and pleasant co-partnership will continue to be source of profit doubtless to them, and of pleasure to their friends in the trade. Mr. Stein is at present in New York City and will be on his way here, returning about the time this number of THE CIRCULAR reaches its readers. In a line with what is said above with reference to credits, Stein & Ellbogen have had an experience which a philosophical prophet could have foretold; they asked their debtors to hurry up remittances owing to them, in order that they might balance their books and retire from business with a clean sheet. The request and the reason given for it had quite the contrary effect, for the average of their customers preferred sending their spare cash to firms whose good will might be valuable to them in future dealings, rather than to a house who, by reason of going out of business, could be of no further use to them, and Stein & Ellbogen would have received more money for past due accounts had they not announced their intended retirement from business.

Chicago's annual moving day, May 1, will not see much change in the location of her jewelers. The Geneva Optical Co. will go into larger premises at 23 Washington street, about a block east of their present location, and the Ansonia Clock Co. will become a neighbor of the Waterbury Clock Co., on Wabash avenue, instead of remaining in their present isolated location on Washington street. The Western Silver Plate Co. have already moved their office from East Madison street to their west side factory.

As predicted in THE CIRCULAR of last month, the successors of Francis E. Morse & Co. now style themselves Morse, Mitchell & Williams. Mr. Morse is at present out of town on one of his flying business trips through the surrounding territory, but is expected back by the first of the month.

H. S. Peck, the enterprising manager of the Waterbury Clock Co., left here on the 11th for Waterbury and New York; he will return in the course of a fortnight.

Indulging in a few more personalities, genial Tom Bristol left Liverpool on a Cunarder on the 13th, and by the time he reaches Chicago his absence from his post at C. H. Knights & Co.'s will have been three months. It is said that he found Paris particularly attractive, and his customers in the South and Southwest are expect-

ing a glowing account of Parisian life when Tom next appears amongst them.

A. W. Ford, of Freeport, Ill., Otto Curtis, of Decatur, W. H. Beck, of Sioux City, M. C. Conner, of Burlington, Iowa., and A. S. Munt, of Fairbury, Ill., were amongst the most prominent of the jewelers who have visited Chicago during the past few days.

Mr. Munt has been a jeweler of Fairbury for a great many years and he has had full opportunity of noting the effect, on the regular jewelry trade, of department store competition. In a conversation with your observer the other day, he stated that Walton Bros., of his town, who run a coal mine, a department store and what not else, have a regular watch and clock department, a department for men's jewelry and a department for ladies' jewelry, and, of course, their salesmen use the same argument so familiar to all customers of such stores. "Mr. Munt, for example," say they, "is obliged to support himself and his family, and to pay all the expenses of store rent, light, heat, etc., etc., out of jewelry exclusively, and must, therefore, ask enormous profits. We (Walton Bros.) are under no additional expense for the maintenance of our jewelry departments, which, in fact, are only a side issue with us, and we can afford to sell a watch at a dollar or two profit, while the exclusive jeweler would starve to death if he did his small business in that way." So it is that the "Jacks-of-all-trades" endeavor to induce the same customers who buy boots and shoes, groceries and dry goods from them, to believe that their stocks of jewelry are marked with the same small percentage of profit. It must also be confessed that these general stores, as a rule, show more enterprise in the arrangement and management of stock, in painstaking care and store attractions, than does the average jeweler, notwithstanding that the only means the latter has of successful competition with a general store is a more careful attention to detail than is possible with a man keeping everything.

Young Mr. Meyer, erstwhile of Kansas City, was the subject of conversation in a group of jewelers, of which your observer made one, in the Palmer House rotunda a few nights since. Boiled down the facts are, that the diamond palace in the Midland Hotel in Kansas City did not yield sufficient profit to balance the extravagances in which young Mr. Meyer indulged; his father, who has a large jewelry business in Hartford, Conn., dropped in upon his son last week and the Meyer, Jr., as quietly dropped out. He is not in Kansas City, wherever else he may be, and Mr. Meyer, Sr., is trying to settle up matters as best he can.

The ingenious swindler, who if he expended the same amount of thought in honorable occupation would soon have a respectable competence, continues to come to grief in endeavoring to make crooked schemes come out straight. F. C. Lewis, alias W. L. Ellis, is the latest Chicago example of this. Producing a card which informed Kind, Abt & Co., wholesale jewelers of this city, that he was a buyer for Daniels, Fisher & Co., of Denver, Col., he selected some \$800 worth of their stock which he intended to become the personal possessor of. The trouble was that a telegram sent by the Chicago jobbers brought about the exposure of the fraud, and Mr. Lewis, or Ellis, is thinking it over behind the bars.

Chicago jewelers are not especially interested in the Pond, Wilmes & Co. failure in Kansas City. So far as can be learned it has occasioned no loss to any of the trade here.

The Elite Watch Co. has been incorporated by S. A. Bobb, W. J. Gregg and M. I. Beck, with a capital stock of \$100,000.

The Chicago Watch Case Co. and the Illinois Watch Case Co., occupying the premises 48 to 62 North Clinton street, had a \$10,000 fire in the early part of this month. The loss was covered by insurance. The Blauer Watch Case Co.'s building at Kenosha, Wis., is nearing completion, and inasmuch as their capital has been doubled, their prospects are flattering.

The Towle Manufacturing Co. are still adding to their large line of fancy novelties. Writing of novelties in silver, your observer is

reminded of a show case just received at the Gorham's Chicago sales-room from B. & W. B. Smith, of New York, who have also recently refitted Spaulding & Co.'s premises here. The case has an almost invisible rim of highly polished rosewood, which serves to cover the joining of the glass; the plate glass is so ground, fitted and cemented as not to require any support other than itself. As compared with old style show case mountings, it is so much more dainty as to be peculiarly appropriate for the display of tasteful jewelry. In this especial case the Gorham Co. display perhaps fifty distinct patterns for the heads of umbrellas and canes, and, all in all, the case and its contents form one of the most graceful exhibitions imaginable. The Gorham Co.'s trade here the past month fully equals that of the corresponding month last year, but this is by reason of the increased demand for large pieces and sets of sterling silver.

The event of the month which proved most interesting to not only the whole jewelry trade, but to the Chicago people in general, was the formal opening of Spaulding & Co.'s jewelry establishment.

It celebrated the completion of all the many improvements which have been made in the building during the past few months, and it also took on the nature of a reception given by Henry A. Spaulding on the occasion of his return from an eighteen years' absence in Paris to this, his former home. It also gave opportunity of wishing Mr. Spaulding *bon voyage*, for being representative of this State to the Paris International Exposition, it was necessary for him to sail for that city on last Saturday and to spend the summer there, Edward Forman, the Secretary of the corporation, remaining meanwhile in charge of the Chicago house.

It was a mild but thoroughly enjoyable Lenten dissipation, and attracted a representative gathering, both of Chicago society and of Chicago jewelers. All during the opening day visitors had thronged the store, but the scene was especially brilliant during the evening. The street being more quiet, enabled a more distinct hearing of the chimes which had been placed on the roof, and the thousands of electric lights within the building intensified the rays reflected from the great collection of rare jewels. A canopy over the Monroe street entrance, a mandolin orchestra, light refreshments, the maid in charge of the ladies' dressing room and the coat room set apart for the men took away the trade appearance of the store.

Nearly all of the elite of Chicago honored him by their presence and some few from out of the city. Prominent among these last were the Vanderbilt party, including Mrs. Wm. H. Vanderbilt, George Vanderbilt and Mr. and Mrs. Sloane. Your observer saw them making purchases that must have run up into the thousands, but the firm refused any definite information. Spaulding's is, indeed, a treasure house of jewels. Its appointments are perfect; its contents will approximate a round million in value. Said an enthusiastic visitor on Thursday evening: "I question whether the combined stocks of all the other jewelers in the town would equal this in value," and he may not have been far from wrong. At any rate there seems nothing lacking that could add to the assortment; so much so as to bewilder one on his first visit.

The cases containing the rarest of the jewels were bordered with rows of small incandescent lights, which added to the dazzling effect. In these cases were precious stones massed together by the handful—diamonds, pearls, rubies, emeralds, sapphires and turquoises without limit, diamonds and emeralds, also, imbedded in the quartz as originally found. Diamond and emerald necklaces, worth anywhere up to \$100,000, black diamonds and diamonds of all colors, diamond rosettes and diamond sprays. Some of these stones have international celebrity. The "Shah of Persia," for example, a diamond weighing thirty karats; the "Star of the West," which weighs over seventy karats.

Should a lady care, as, of course, she would care, to know just how any of these jewels would appear at night with a costume worn *en décolleté*, she can retire to the privacy of a little satin-hung room, called the "gem boudoir." This little room is walled with mirrors,

and contains all the luxurious toilet accessories possible to imagine. Just outside of this boudoir is a buffet, supplied with French china and all the requisites for the serving of a delicious cup of tea—in fact, an urn of tea is to be kept steaming continuously at the side of it.

These and other such appointments, all in keeping with the dignity of the establishment, will occasion enthusiastic comment from all visitors to the city, and will add to the fame of Spaulding & Co.'s enterprise, and of Chicago as the home of the most complete jewelry store, with one exception, in the world.

The Centennial of Washington's inauguration will have fit celebration in Chicago, and that the jewelers are taking an active interest in it is proven by the liberal contributions they have made. Some of the names are: Spaulding & Co., \$50; C. D. Peacock, \$25; Mayo, Groff & Co., \$25; Giles, Bro. & Co., \$25; S. Hyman & Co., \$25; Juergens & Andersen, \$25; Robbins & Appleton, \$25; F. E. Morse & Son, \$25; Shourds, Storey & Kasper, \$25; Benj. Allen & Co., \$25; Meriden Britannia Co., \$25; Elgin National Watch Co., \$25; Rowe Bros., \$25; Joseph & Fish, \$25; Otto Young & Co., \$25; M. A. Mead & Co., \$25; J. B. Chambers & Co., \$25; C. H. Knights & Co., \$20; A. H. Smith & Co., \$20; Henry Oppenheimer's Sons \$10; F. M. Sproehle & Co., \$10; Gorham Mfg. Co., \$10; Morse, Williams & Co., \$10; Simpson, Hall, Miller & Co. (by M. M. Burchard, agent), \$10; E. V. Roddin, \$10; Towle Mfg. Co., \$10.

THE CIRCULAR'S OBSERVER.

THE "POESY" ENGAGEMENT RING.—A new-old style of engagement ring, a revival of the "poesy" or "chanson" rings that were in the height of fashion in the 16th century, is being revived in this country. The ring is quite massive, and but for its palpable newness would seem more at home in a collection of antiquities than in a modern shop. The band is fully one-third of an inch wide and thick in proportion. At the front is an artistically-executed ivory intaglio of octagon shape and about one and a third inches long and one-half an inch wide, this being surrounded by small brilliants of the finest quality. When one slightly presses a small projection at the side of the octagonal shield it slowly revolves and clicks firmly into place, reverse face front. Two entwined initials, outlined in small and contrasting gems (mainly rubies, sapphires and diamonds) are then visible. The beauty of the workmanship of this face can only be fully perceived and appreciated with the aid of the glass. Inside the band is a fine specimen of the engraver's art in the shape of a couplet perhaps in quaint Gothic characters, running as follows:

Love him who gave thee this ring of gold:
'Tis he must kiss thee when thou art old.

It is an engagement ring, and is frequently designed by the donor, who purchases the ivory intaglio abroad. This style is new to the present generation and is in almost every respect a revival of the "poesy" or "chanson" rings which were the height of fashion in the sixteenth, seventeenth and eighteenth centuries. Since that period finger rings have gradually become less massive and elaborate until at the present time the acme of fragility compatible with durability and strength has been reached. The demand has continually been for less weighty bands and more impalpable gem settings, and in all probability will so continue. It is fairly possible, however, that the ponderous poesy and chanson styles may have another inning, though it is too early to decide positively, as the revival only recently took place.

SUBSIDY.—The director of the German horological school at Glasshütte (Moritz Grossman's school), L. Strasser, acknowledges the receipt of the customary annual subsidy of 5,000 marks, made by the royal government of Saxony.



TRADE GOSSIP.

The following named jewelers were seen in town during the past month :

Mr. Hardy (Hardy & Hayes), Pittsburg, Pa.; H. E. Kirstein, Rochester, N. Y.; W. C. Taylor, Springfield, Mass.; M. Bauman (L. Bauman Jewelry Company), St. Louis, Mo.; C. M. Velsey, Troy, N. Y.; J. Schlesinger, Albany, N. Y.; L. Blass, Little Rock, Ark.; E. D. Mix, Albany, N. Y.; R. Goldschmid, Washington, D. C.; C. S. Gill, Lancaster, Pa.; C. Osgood, Lewiston, Me.; G. Jackson, Philadelphia, Pa.; J. Hopkins, Baltimore, Md.; C. Weber, Philadelphia, Pa.; T. Dickinson, Buffalo, N. Y.; F. E. Doolittle, Elmira, N. Y.; M. Freudenheim, Elmira, N. Y.; M. Katz, Harrisburg, Pa.; A. W. Kelly, Syracuse, N. Y.; W. Wheeler, Beloit, Wis.; H. Friedstein, Marinette, Wis.; W. Gault, Montreal; J. Yeager, Philadelphia, Pa.; N. B. Levy, Scranton, Pa.; E. Schimpff, Scranton, Pa.; J. J. Freeman, Toledo, O.; C. A. Bell, Newberne, N. C.; F. A. Sadler, Baltimore, Md.; J. Miller, Blossburg, Pa.; J. Ryan, Atlanta, Ga.; N. Stoddard, Harrisburg, Pa.; M. Schwed, New Haven, Conn.; M. Bonn, Pittsburg, Pa.; B. Samuels, San Francisco, Cal.; L. Levy, Syracuse, N. Y.; A. S. Bigelow, Boston, Mass.; E. W. Baumgardner, Toledo, O.; F. Rand, Portland, Me.; Mr. Warner, Bridgeport, Conn.; L. G. Jahnke, Lexington, Va.; J. Williamson, Montreal, Can.; M. Saunders, Toronto, Can.; W. N. Boynton, Chicago, Ill.; G. H. Ford, New Haven, Conn.; J. Muhr, Philadelphia, Pa.; J. Harrington, Rochester, N. Y.; J. Ridley, San Francisco, Cal.; C. S. Hollinshead, Philadelphia, Pa.; C. T. Anderson, Reading, Pa.; J. H. Smith, Baltimore, Md.; M. Timpane, Troy, N. Y.; J. S. Naylor, Wheeling, W. Va.; C. C. Terry, Hudson, N. Y.; W. Vosburgh, Chicago, Ill.; D. F. Conover, Philadelphia, Pa.; E. Scheuer, Toronto, Canada; W. D. McLean, Troy, N. Y.; L. Helwig, Chicago, Ill.; T. Hunter, Utica, N. Y.; H. E. Hall, Springfield, Mass.; F. C. Richards, Bellefonte, Pa.; A. S. Mermod, St. Louis, Mo.; W. Eaves, Montreal, Canada; B. Phillips, Elmira, N. Y.; W. J. Bachelder, Boston, Mass.; I. Mitchell, Kingston, Ont.; J. Lewis, Boston, Mass.; S. Rothenburg, Meridian, Miss.; E. Wolff, Binghamton, N. Y.; J. Loeb, Ticonderoga, N. Y.; C. J. Foster (Geo. C. Shreve & Co.), San Francisco, Cal.; H. A. Bohm, Cincinnati, O.; C. Jarecki, Erie, Pa.; W. S. Eckstein, Salem, O.; B. Mandelbaum, Hartford; H. Semken, Washington, D. C.; Howard Tully, Fort Worth, Tex.; H. G. Munger, Herkimer, N. Y.; H. E. Hall, Springfield; H. A. Bohm, Cincinnati, Ohio; C. C. Terry, Hudson, N. Y.; A. J. Jenks, Springfield, Mass.; C. J. Williams, Chicago, Ill.; J. L. Keck, Cincinnati, Ohio; S. Oppenheimer, Baltimore, Md.; H. Schussler, San Francisco, Cal.; H. Norcross, Boston, Mass.; L. Lake, Baltimore, Md.; E. W. Atwood, Bridgeport, Conn.; W. F. Carlton, Rochester, N. Y.; E. Rowe, New Haven, Conn.; C. S. Gill, Lancaster, Pa.; G. W. Davis, Rochester, N. Y.; E. C. Patterson, Boston, Mass.; J. Meyer, Buffalo, N. Y.; R. C. Munger, St. Paul, Minn.; H. S. Atterbury, Indianapolis, Ind.; C. R. Hotchkiss, Memphis, Tenn.; G. Gay, Hartford, Conn.; J. Campbell, Hartford, Conn.; S. Stein, Chicago, Ill.

—On April 6, at Charleston, S. C., occurred the death of R. H. McDowell, well known in the jewelry trade as the bookkeeper for the prominent house of A. H. Hasen & Co., of that city. He had been twenty years with the firm, during which time he had built up for himself a position of such confidence as to be considered virtually the right-hand man of the firm. His obsequies were under the direction of the Washington Light Infantry Veteran Association, army of Northern Virginia.

—Capt. W. L. Coffinberry, of Grand Rapids, Mich., died suddenly in that city on April 2, at the age of 84 years. The deceased was born in Ohio, and when 18 years of age became an apprentice to a watchmaker. He learned the trade thoroughly, and, moving to Grand Rapids in 1844, started a watch repairing shop, which he conducted for several years. He obtained his title of Captain from the part he took in the famous Toledo war. He was also one of the organizers of the Michigan regiment of engineers and mechanics.

—Sam Mayer has sold out his business at Leadville, Col., to Joseph Coban.

—Irving L. Russell, 18 John street, will share offices in the Corbin Building with Henry C. Haskell.

—L. S. Stowe, of Springfield, Mass., has been elected President of the City National Bank of Springfield, to officiate in the absence of J. D. Safford, who has gone on a protracted vacation.

—Advices from the Seth Thomas Clock Co.'s Australian agent, D. Manson, state that his company obtained the highest award at the Melbourne Centennial Exhibition for its precision clock.

—The trade was grieved to learn of the death of Roy, the three-year old son of George W. Parks, with Howard & Son, which occurred on April 5. The boy, who was an unusually bright child, had been ill for three weeks, during which time his father had seldom left his bedside.

—A. K. Sloan, of Carter, Sloan & Co., has returned from the West Indies, where he had sojourned with his family for over a month.

—G. H. Houghton and Russell Spaulding, of the Gorham Mfg Co., left for Europe March 31 by the *Etruria* to take charge of the company's exhibit at the Exposition. W. R. E. Berth also left by the same steamer, to superintend the leather department exhibit of the house.

P. A. Lee, the veteran "hustler" of the Wiesbauer Mfg. Co., Buffalo, will shortly, in the interest of the firm, open an office in Chicago, which he makes his future home, and point out to his western friends certain reasons why they should deal largely with the firm he so ably represents.

—The months of March and April were very busy ones in the establishment of S. F. Merritt, of Springfield, Mass. In addition to the usual active demand for his goods, a new steel eye-glass holder finished in nickel, bronze and blue and black enamel was in March placed upon the market and met with almost instantaneous success.

—J. Briggs & Sons, of Providence, R. I., are constantly adding new and improved machinery to their plant, and are making better finished plate and wire than ever before. They are producing some very handsome new patterns in fancy wire which will be ready for inspection by June 1. Over two hundred patterns in fancy wire, suitable for the manufacture of bangle bracelets, now so much in vogue, are displayed, and the most fastidious should be satisfied.

—The American Watch Tool Co. has just introduced its new Webster-Whitcomb lathe for watch repairers, a representation of which appears on another page. With the exception that it requires a No. 2 chuck, has 11 inch bed and improved tailstock, it is essentially the same as the Whitcomb 1 1/2, so familiar to the trade. The company, owing to the constantly extending volume of business, has increased its force of workmen to 75 hands. We would advise the trade to send for the reduced price list.

—It had been thought for some time that it was impracticable to manufacture clocks in Canada on a successful basis. The failure of the Canada Clock Co. some years ago confirmed this opinion, and the field had been left practically vacant until E. P. Baird, formerly with the Seth Thomas Clock Co., associated himself in May, 1888, with his brother, G. D. Baird, under the name of Edwin P. Baird & Co., and conceived the idea of buying American movements and applying them to Canadian cases. Though at the first numerous impediments were encountered, the business is now on the high road of success.

—On Easter Sunday St. John's P. E. Church at Savannah, Ga., received perhaps the handsomest eagle lectern ever produced. It is the work of the Gorham Manufacturing Company, and is the gift of a prominent parishoner of Grace Church. The height of the lectern is 6 feet 8 inches; the base is curved octagonally, rests upon four lions couchant, and supports four heavy pinnacles with flying buttresses. Between the buttresses are statuettes of the four Evangelists, excellently modeled in bronze. The shaft is full of pierced tracery and is surmounted by an octagonal cap; on this is the eagle with outstretched wings, set in a crown of glory. A remarkable feature lies in the poise of the bird, and the unconventional treatment of the head and wings.

—Jewelry and watch case manufacturers have always appreciated the "Otto" gas engine as the most convenient power for driving their machinery, and the small vertical 1 horse power engine has been quite a favorite in the trade, owing to its low first cost and the simplicity of its mechanical parts. The builders of these engines offer them now of as high power as 50 horse power, and have sold a number of them to gas companies engaged in electric lighting. Not quite so large an engine was recently installed in the store of J. E. Caldwell & Co., Philadelphia, to run their pumping machinery for hydraulic elevators, ventilators and polishing machines. For such work the "Otto" of 10 horse power and upwards is admirably adapted and is more generally used every day.

J. B. BOWDEN & CO.,

On or about May 1st, will remove to

THE CORBIN BUILDING,

(See Page 43.)

Broadway and John St., New York.

Why the COLUMBUS WATCH is THE BEST.

- 1st. The Main Spring barrel is completely covered, making the watch perfectly dust proof.
- 2d. There can be no interference between the Balance and the Barrel.
- 3d. The Regulator is nearly double the length of others, rendering accurate regulation a very simple matter.
- 4th. To replace a broken Mainspring, the Barrel can be removed without disturbing the Balance or interfering with the regulation.



18 Size.

COLUMBUS WATCHES

ARE ORIGINAL IN CONSTRUCTION,
BEAUTIFUL IN DESIGN,
ABSOLUTELY RELIABLE,
ACCURATE, DURABLE,
And DUST PROOF.



16 Size.

SPECIAL MENTION.

KNOWING the requisites of the trade, in supplying the demand for Railroad Watches that will bear the closest inspection and most exacting service, we have made grades Nos. 18, 28, 27 and 35 expressly to meet those requirements. We highly recommend them to the trade as being the best finished, handsomest in appearance and most accurately rated Timepieces made, at corresponding prices, and we especially call your attention to these grades.

Ask Your Jobber for Columbus Watches.

P. O. BOX 1155.

AIKIN, LAMBERT & CO.

23 MAIDEN LANE, NEW YORK,

(GOLD PENS, HOLDERS, PENCILS, TOOTHPICKS,
Glove Buttoners, Match Boxes, Novelties,
PAUL E. WIRT AND OTHER FOUNTAIN PENS.)

Manufacture



JAS. C. AIKIN,
H. A. LAMBERT,
JOHN B. SHEA.

The attention of responsible buyers is invited to Special Bargains in our line of Swiss Watches, Discontinued American Movements, Diamonds and Jewelry. Goods made to order in our own Factory.

ORDERS PROMPTLY FILLED. AMERICAN MOVEMENTS WITH OR WITHOUT CASES.

—Charles A. Fowler, of Fowler Brothers, was last month elected Treasurer of the Prentiss Calendar and Time Co., of New York.

—On April 6, G. Louis Fox, of M. Fox & Co., left for Europe to make large purchases in fancy gems. He will be gone about four months.

—For two weeks Simon Stern, of Stern & Stern, was confined to his home with a severe attack of erysipelas. He returned to his duties on the 29th, looking we are happy to say, well and hearty once more.

—Hugo Sussfeld, the son of Mr. Sussfeld of Sussfeld. Lorsch & Co., who about two years ago, came from the Paris house, to enter the business in New York, returned to Europe on the 27th ult. by the steamer *La Bretagne*.

—George Terry, well known as a patent attorney in New Haven, died suddenly from apoplexy in his office in that city on the evening of April 8. He was the son of Eli Terry, the father of the clock-making industry of the country. Mr. Terry was 65 years of age at his death, and was a single man. In his youth he had incurred the displeasure of his father and was all but disinherited. In his patent business he was very successful.

—Wm. C. Edge, of Wm. C. Edge & Sons, was granted last month a patent for an improvement in machinery belting that, from its nature, must insure him success. This belting consists of a strip of knitted wire having a practically smooth or flush side for contact with the pulleys, while the ribs of the wire are on the reverse side. By the use of wire the possibility of slipping is reduced to a minimum, there is less friction, hence less electricity generated, and the cost of the manufactured article will be cheap in comparison with the belting made from other materials.

—Orders for the new 7-jeweled movement made by the New York Standard Watch Co. are rapidly accumulating, duplicates being especially numerous, and export orders being many and increasing. At the factory, which turned out in April about double what was produced in March, more finishers and other hands have been employed. The May output will exceed that of April. If dealers desire to know what other dealers think of the Standard Watch, by writing to the New York office, in the new Corbin Building, 13 John street, they will have furnished them, a little pamphlet containing numerous testimonials.

—In order to facilitate their business relations with the watch factories of the United States the Usine Genevoise de Degrossissage d'Or, of Geneva, Switzerland, have appointed Hipp Didisheim, 83 Nassau street, New York, their special agent for the United States and Canada, to whom correspondence should be addressed for prices, terms, etc. A. Hoffer continues as general agent for North America, will answer all questions regarding technical points and superintend the good execution of their anti-magnetic products. Dickerson & Dickerson, counselors-at-law, Temple Court, New York, have been intrusted with the surveillance of the company's patents.

The Seth Thomas Clock Company has obtained the contract for the installation of a large clock to grace the square tower of the San Francisco *Chronicle* building of San Francisco. It will be the largest clock in America; the dials, four in number, are 16 feet each in diameter; they will have outer rims of copper, and the central portions 11½ feet in diameter will be of ground glass. The time will be indicated on the copper by day and on the glass by night, the former carrying gilded numerals of brass two feet in length. The glass portion will be in seven parts, six being segments of a ring, and the seventh, a circular disk, 7¼ feet in diameter. The numerals on this face will be black to stand out clearly in the light generated behind the face. The pendulum is to be 14 feet long, the 'bob' weighing 500 pounds. Motive power will be imparted to the mechanism by a weight of about 600 pounds, and it is claimed that the time will not vary ten seconds in a month.

—E. S. Johnston & Co., have given up their temporary office in the Knapp Building, at 41 Maiden lane.

On March 30, a bill in equity to restrain James W. Queen & Co. from infringing upon the patent for adjustable nose pieces for eye-glasses, was filed in the United States Circuit Court, at the instance of Ivan Fox, the optical instruments manufacturer, of Philadelphia. In the bill, it is claimed that Mr. Fox is the inventor of the well-known adjustable soft metal nose piece, now widely used. The suit is a test case, the issue of which will have an important bearing upon the manufacture of optical goods throughout the United States.

—Perhaps the largest and best assortment of timing and complicated watches to be found in this country, can be displayed in the office of Mathey Bros., Mathez & Co., 16 Maiden Lane, New York. They are constantly improving and increasing their stock, and are, month after month making them their special feature of business. Chas. C. Mehlan of the firm, is in constant attendance at the factory at Brassus, Switzerland, which is at present undergoing several improvements. A point, in connection with these watches, which do not fit the regular sized American cases, that cannot be too forcibly emphasized resides in their capability of being cased in three days at the outside, owing to the fact that they are manufactured with the center piece of the case complete, with repeater slide for repeaters, or with push for chronographs, leaving only the front and back to be made. A full line of non magnetic movements fitting 16 size cases, and a line of fancy cased fine ladies' watches are also carried.

—Of the numerous improvements that have been made during the past twenty years in spectacles and eye-glasses those in aluminum, manufactured by the Spencer Optical Manufacturing Company, occupy a lofty prominence. These goods, which the company is introducing throughout the country, are made in that wonderful mineral, aluminum, which renders them light and durable, and capable of as high polish as varnished rubber, without that metal's fault, of tarnishing. These specs are made in regular single bow, two different sized eye, and light flexible R. B., or an R. B. with the spiral adjustment in the butt of the bow, which adjusts itself to the varying distance between the temple and the ear. The spiral is protected by a tube or barrel, does not disfigure the spec or make it appear cumbersome, and prevents the pressure back of the ears and the ridging of the nose produced by the old style. Aluminum is not affected by moisture in the least, possesses the flexibility of gold, and will never tarnish. The Spencers are much elated over the success that has crowned their efforts of several years, and they anticipate a great demand for these goods from the first-class dealers, who will appreciate the importance of this invention.

—Koch & Dreyfus opened their new office at No. 22 John Street on April 24th and are now fully prepared to fill all orders. They will continue to carry their usual large stock of diamonds, watches and jewelry, and will also fill orders in all lines of goods handled by the jewelry trade. The firm is widely known and respected, and has been in existence 40 years, Mr. Nathan Koch starting in New Orleans, in 1849, in a room on Rampart street. He was his own traveler, bookkeeper and general utility man. The business prospered until in 1866, when Mr. Leon Dreyfus was admitted into partnership and in the following 20 years the house advanced to the first position among the jewelry jobbing houses of the South. Mr. Jonas Koch, son of the founder of the firm, was admitted a partner in 1885. The present removal to New York is made with the object of extending their trade throughout the United States, and securing the advantages of situation which the metropolis affords. They will retain their old force of travelers and some of their office employees. Mr. Dreyfus arrived on the 29th, to assume charge of affairs, Mr. Koch, senior, remaining in New Orleans, until June 1st, to close out the business there, after which he will embark for Europe. Mr. Jonas Koch, the junior member, has been in New York for some weeks arranging the details of the removal.

—Chas. F. Wood has secured the special agency for one of the largest half pearl cutters in Europe. Mr. Wood's stock of gems and precious stones at the present time is very large.

—Manager John C. Bacon, of the New York store of the Meriden Britannia Company, in company with J. W. Miles, of Meriden, sailed for Europe on the 13th of April by the steamship *La Bourgogne*.

—We call the attention of the trade to the advertisement of Oppenheimer Bros. & Veith, in regard to the discontinued movements of the Columbus Watch Co. which they offer to the trade at a very great reduction.

—T. B. Bynner, 177 Broadway, offers to the trade a fresh assortment of diamond jewelry and novelties in plated jewelry, and it is hardly necessary to say that his stock is well selected and quite up to the tone and demands of the market.

—George F. Kunz sailed for Europe on April 20 by the steamer *La Champagne*, to represent Tiffany & Co. at the Paris Exposition, and also as special agent for the United States Exposition Committee, to take charge of the government mineralogical and metallurgical exhibit.

—Cattelle & Decker have introduced a novelty in silver goods which is meeting with good favor. It is a combination letter weight and stamp box, on which are engraved the rates of postage for printed and written matter. A number of other novelties will be ready for the trade during the month of May.

—An article that will create a lively demand during the summer, owing to its especial appropriateness to the style of wear that will prevail during that season, is a patent clamp scarf-fastener, manufactured by John A. Riley, 860 Broadway, New York. It is made in 14-karat gold and in sterling silver, and in plain, chased and jeweled designs.

—The Ansonia Clock Co. present to the trade in this number three illustrations of a new timepiece, which it has named the "Jumper;" it certainly has a very attractive appearance and should have a very ready sale. The Chicago office of the company has been moved from 64 Washington street to the large building 133 to 135 Wabash avenue.

—On April 24th, Henry Zimmern left for Europe by the *Saale*.

—J. W. Richardson & Co., manufacturers of emblems, charms, pins, etc., are preparing many new designs in their goods which will be ready for the opening of the jobbers trade in July, and it is likely that they will issue a supplement to their catalogue in time for the season's business.

—Julius Wodiska recently had the work of making two gold badges for Barnum & Bailey, the circus magnates, to be presented as a testimonial of their bravery to the two *Evening Sun* reporters, N. A. Jennings, who entered one of their lions' cages, and W. J. Rouse, one of their tigers' cages. The badges are handsomely engraved with the compliments of the donors.

—The Pairpoint Manufacturing Co., until the Lenten season had been running the factory full time. Its spring trade was especially good, owing to a number of little novelties that it placed upon the market in bon-ton trays and boxes, old silver nut bowls, etc. The latest novelty of this company is a French lunch set, consisting of after-dinner coffee cup and plate for cake combined.

—A new firm of manufacturing jewelers has been started at 69 Nassau street, under the style of Van Benschoten & Lassner, composed of Arthur Van Benschoten, who for 4 years had been with A. Bernhard & Co., and Joseph Lassner, for three years with L. & M. Kahn & Co., both young and enterprising men of good reputation. A prosperous career is looked forward to for these new comers.

—The Trenton Watch Co., has shipped to the Paris Exposition a large exhibition case surmounted by a mammoth representation of a Trenton watch, together with a large number of its well-known watches. The company expects to excite astonishment from foreign manufacturers, at the excellence, finish and exceedingly low price of its watches. The output of the Trenton factory in March was 215 watches per day.

—At the meeting of the Executive Committee of the Business Men's Republican Club, recently held, J. B. Bowden, as president of the Jewelers' Legion, was specially commended to the President as having been a most active worker during the campaign.

—An odd Centennial souvenir issued by the Leroy W. Fairchild Co., New York, consisted of a little hatchet of red-colored pasteboard, on one side of which is printed "George Washington" together with Daniel Webster's well-known eulogium, and on the other side the firm's name, with a travesty on the quotation, "first in gold pens, first in pencils, and first in novelties and small wares in gold and silver."

—Miller Bros. & Co., 37 Union square, New York, are displaying an unusually large line of new sleeve buttons of most tasteful designs. In gentlemen's, we notice a large assortment in oxidized silver, with 14-karat gold flower, insect, or leaf ornamentations in relief, in numerous shapes—square, polyangular, circular, etc.; there is also a line of ladies' buttons in beautiful designs. The firm's cloisinée initial buttons are meeting with their usual demand. A line of new designs, the initials being in blue enamel, is shown, their beauty exciting much admiration from the beholder.

—The Leroy W. Fairchild's Co.'s exhibit at the Paris exposition, left the country on April 20th, by *La Champagne*. The exhibit, which is well-representative of the company's productions, consists of gold pens, pencil cases, novelties and small wares, such as flasks, cigarette cases, match boxes, etc. The articles are all most tastefully and artistically designed, in lately conceived patterns, and lay ensconced in black velvet trays, with a show case producing a beautiful effect, which, combined with the white and gold effects of the setting that surrounds the case as a canopy, makes an ensemble of unusual elegance. George W. Fairchild will have supervision of the display, which is to occupy a 10-foot square space.

—On the 6th the trade received a surprise in the shape of the failure of Pond, Wilmes & Co., of Kansas City, Mo. The assignment was made to P. P. Burroughs, who filed a bond on the Monday following and took possession of the business. The assets are claimed at \$25,000 and the liabilities in the neighborhood of \$80,000, the claims being held chiefly by Providence and Attleboro houses. The causes assigned are poor collections and small business. There are no preferred creditors, and the assignee thinks that the firm will pay on the basis of 20 cents. The firm was organized only in September last by Clarence E. Pond, who for five years was well known as a traveling wholesaler, and W. F. Wilmes, erstwhile salesman for Duhme & Co., and manager of their Kansas City branch. At Mr. Duhme's death, last September, he bought out the fixtures of the store he managed and which was closed out, and the firm of Pond, Wilmes & Co. came into existence. A capital of \$23,000 was claimed by them, free from debt. The trade opinion obtains that the firm was not very good and was considered slow pay.

—In the Part 2, Volume I., of the Massachusetts census, recently issued, may be gleaned some interesting statistics relating to the watchmaking and jewelry trades. The total number of persons employed in the manufacture of clocks and watches is stated as 3,149. Of these, 2,105 are male, of whom 256 are between 14 and 19 years of age, 774 between 20 and 29 years of age; 967 are native born, the remaining States 656, and England 150. Of the female employees, 1,044 in number, 164 are between 14 and 18 years of age, and 648 between 20 and 29 years of age; 424 are native born, the remaining States 429, and England 24. In lapidary and burnishing work 21 are engaged, 20 being males. Only 6 are foreign born. Of retail dealers including 13 peddlers, there are 350, of whom 3 deal in watches exclusively and 58 in watches and jewelry. There are 152 salesmen, 121 males; of bookkeepers there are 107, of whom 46 are males (an interesting fact to males depending upon this pursuit for a livelihood). Clock repairers number 41 and watch repairers 88. These figures are the latest compilation, though they are not this year's.

—The Jaccard Watch and Jewelry Co., of Kansas City, Mo., has increased its capital stock to \$100,000.

—R. N. Peterson, of Peterson & Royce, importers of diamonds, sailed for Europe, on the *Germanic*, Tuesday, April 30th.

—On May 1st E. Karelsen moved from 95 Fifth avenue to No. 16 Maiden lane, where he occupies the office formerly of W. H. Lyon.

—W. F. Duryea, representative of the New York Watch Case Company, has moved his office from 41 Maiden lane to 71 Nassau street, Room 10.

E. I. Franklin & Co. and W. G. Hopkins have moved from 5 Maiden Lane to 176 Broadway, into the quarters vacated by Hamilton & Hamilton, Jr.

—On March 30 Albert Lorsch left for Europe by the *Etruria*. He will remain in the old world for four months, during which time he will send over large invoices of new goods.

—Jewelers who may lose either precious or imitation stones from jewelry, should notice that Wm. Archibald, of 73 Nassau street, makes a specialty of supplying stones of every kind to the trade.

—The suit for \$1,000 of John C. Dueber against Lapp & Flershem, Chicago, was tried in the Superior Court, before Judge Clifford, on April 17, and resulted in a verdict for \$482 in Mr. Dueber's favor.

—The trouble between Gustave Rehman and Thos. C. Jones, arising from the co-partnership that formerly existed between them, has been finally settled. The case will therefore not be tried in the courts, as was anticipated.

—Ludwig Nissen & Co., No. 18 John street, report an increase in their business since the admission of Alex. C. Chase on January 1st, far beyond their expectations. Mr. Nissen and Mr. Chase are both hustlers and not the men to be satisfied with anything less than a boom.

—H. M. Wilson, who has been in the employ of W. W. Mansfield & Co., Portland, Me., for several years, and to whose efforts the successful career of the house is, in a great measure, due, has been admitted as partner into the firm.

—Gerhard Heitkemper has disposed of his store fixtures at Hastings and other places in Nebraska to O. C. Zinn, of Omaha, Neb., and will move to Portland, Ore., where he will engage in the jewelry business as soon as he finds a suitable location. His address after May 10 will be 130 Third street, Portland, Ore.

—Albert Berger & Co. have received and have now open one of the largest stocks of optical goods of their own manufacture which they have ever handled. Their facilities for sale and shipping are also much improved, evidences of increased business which we are pleased to record.

—On page 3 will be found a table showing the effects of changes of temperature upon the watches submitted by the Seth Thomas Clock Company to the United States Naval Observatory for trial in the temperature room. The results were highly satisfactory and demonstrated the reliability of the Seth Thomas watch most clearly.

—Irving L. Russell, Corbin building, Broadway and John street, New York, has in stock a remarkably handsome line of fine diamond jewelry of all kinds in addition to a large assortment of diamonds and other precious stones, fancy pearls and pearl necklaces. Mr. Russell, invites memorandum orders, and will furnish designs and estimates,

—The numerous friends of Lawrence Knepfly, of J. Knepfly & Son, Dallas, Tex., have been for some time urging him to accept a candidacy for Mayor of his town. All entreaties, however, have been met with refusal, as he prefers the quiet life of a private citizen. The popularity that Mr. Knepfly is said to enjoy in Dallas would, no doubt, ensure his election if he consented to run for the office.

—On May 1, D. W. Granbery & Co. celebrated the silver wedding of their occupancy of the store, 20 John street, by quitting it and occupying the store at 189 Broadway. Their new quarters are fully 100 feet in depth, and in addition the firm has leased the basement. Several new departments will probably be introduced, and a larger assortment in every line, especially that of Royal Worcester ware, will be carried.

—The Chicago Watch and Case Co., whose works at 56 and 58 North Clinton street, Chicago, were recently destroyed by fire, has recommenced business at Lake and Jefferson streets. The company will continue as heretofore to apply itself to special watch case work, the making of old cases new and salable, plating of every description and to the repairing of movements. When desired, new goods of any make will be shipped with the return of repair work.

—I. H. Gurnesey leaves his business at Hastings, Neb., in charge of F. E. Hewitt to accept the management of the C. H. Green Jewelry Company, of Denver, Col., the reorganization of Blythe, Lehman & Co., dissolved some time since. Mr. Gurnesey had before starting his enterprise at Hastings been connected for years with the erstwhile firms of Clapp & Davies and L. H. Gurnesey & Co., of Chicago, so he brings a ripe experience into his new position.

—The hospitality of New York City on the occasion of the recent Centennial, will long be remembered by its visitors, but among the special instances we note that of Miller Bros. & Co., who not only at considerable expense fitted up their elegant office on Union Square for the accommodation of about 100 of their friends, principally ladies, but entertained them with a generous collation. The Miller brothers know just *how* to act the host and they *did* it.

—Edwin A. Thrall, importer of precious stones and jobber of American watches, 3 Maiden Lane, arrived from Europe, April 25th, by the *City of New York*, bringing with him a large assortment of particularly fine stones—diamonds, rubies, sapphires and pearls. Mr. Thrall sought for opals throughout the European markets, intending to buy a large assortment of them, but he was able to obtain only a few, though they are of exceptionally fine quality. A well-known stone dealer, when a line of spinelles brought over was submitted to his opinion, pronounced it to contain some of the best that had ever come under his notice.

—The Seth Thomas Clock Co. has contracted with the Self-Winding Clock Company for 1,000 self-winders, which are to be made complete. The Self-Winding Company has obtained nearly all the patents relative to transmitting time or synchronizing clocks by wire and has made a contract with the Western Union Company to furnish it with self-winding and other clocks, which the latter company will put out on rental. These clocks will be synchronized at noon from the Naval Observatory in Washington and the Western Union Company is ready to put them up wherever its wires run. The Seth Thomas Company has arranged with the Self-Winding Company for the sole manufacture and sale of these self-winding clocks, other than those which are to be synchronized, and expects to put a line of them upon the market next fall. It is no new business to the company, as it made a portion of those which the American Manufacturing and Supply Co. has been selling for the past two or three years.

—The eager demand for Seth Thomas tower clocks still continues. The company recently received orders for a quarter striking clock for Waterville, N. Y., a street clock for Sydnew, New South Wales, a chiming clock for Mexico (paid for from the financial results of a series of bull fights, arranged by a number of prominent ladies), and a large clock and bell for the Polytechnic Institute, Auburn, Ala. The company's nickel watch movements are in greater demand than can be accommodated. In fact, all branches of the business are particularly active, with the exception, perhaps, of that devoted to mantel clocks. This business is evidently passing into the hands of the installment men, who buy cheaper clocks than it is the policy of the Seth Thomas Company to produce. One of the company's precision clocks has been shipped to Paris in connection with the government exhibit, to illustrate the Gardner system of transmitting time and synchronizing clocks by electricity. At the March meeting of the stockholders of the company it was voted to increase the capital stock \$200,000, which makes the capital \$800,000.

—The Atlantic Watch Case Co., Corbin Building, Broadway and John st., New York, is placing upon the market an unusually handsome line of 14-k. filled, screw back and bezel cases. Among them are displayed numerous designs which are far better in execution than is common with filled cases, and which for beauty exceed many productions in solid gold. The company is also manufacturing an anti-magnetic nickel watch case which is meeting with popular favor, by reason of its filling a want that has long been experienced—a horological non-magnetic appliance at a low price. Any movement, whether of a high or low standard, cased in one of these, is thoroughly protected against all magnetic and electrical influences; the material used in its manufacture is of great strength, insuring it almost against injury; the case is dust proof, being screw back and bezel, and its price is but little more than that of an ordinary German silver case. This case is specially recommended for use by conductors, engineers and railway employees, generally; by persons engaged in electric light establishments, more especially those working in close proximity to dynamos; by passengers on electric railways, and by the general public. This is absolutely the only anti-magnetic nickel watch case manufactured, and it must not be confounded with any shield, insulator, or the like.

—Philipp Thoma, has moved from 15 Maiden lane to 21 John st.

—Upon application, dealers will be supplied from the Seth Thomas Clock Co. with a neatly bound little book containing considerable information in reference to the company's watch movements.

—C. C. Hinckley & Co., the well-known tool manufacturers, of Aurora, Ill., are being urged to form a stock company for the object of extending their business and increasing their facilities for manufacturing.

—H. E. Beguelin, of Cross & Beguelin, accompanied by his family left for Europe on April 27 by the steamer *La Bretagne*. Among other places, he will visit Paris to purchase diamonds and tools, Switzerland to buy watches and Carlsbad to recuperate his health.

—Edwin Want, the optician, is now settled in his new quarters at 14 John street, where his facilities for manufacturing and repairing are of the best. Mr. Want has a well-selected stock of goods for opticians, and his reputation as a reliable business man and a thoroughly practical optician is undisputed.

—Jacot & Son will open their new store, 298 Broadway, New York, with perhaps the largest and most varied stock of musical boxes, novelties and curiosities in musical goods to be found on this continent. The jewelry trade, which largely patronize this firm, are cordially invited to call and examine their stock.

—The Waterbury Watch Co. issued with its April *Waterbury*, an attractive Easter souvenir in the shape of a little hanger showing a large easter egg within which radiates a Waterbury watch. A figure of a fairy surmounts the egg, and a goblin pointing toward the egg is asking a rabbit, if he could beat it for an easter egg? The rabbit evidently answers in the negative.

—The "1889 Princess circular" will be mailed to every dealer in the United States and Canada. It is a convenient little sheet, as it shows the latest designs and all the new features of the well-known "Princess" initial rings, gives complete descriptions and numbers of the goods, so that the dealer can order by the number of any wholesale house as it has a duplicate circular.

—A well-known Buffalo jeweler, recently returned from Europe, speaks of a little paper box having on the top a fine lithographic view of Niagara Falls, which was given to him with a small purchase he made when viewing Niagara in London. He says it was a very beautiful novelty, and that he was not aware at the time that it was the production of a well known house in America.

—One of the latest fads in bangle bracelets now so popular, is the "Shakespeare." It is made of sterling silver, and in the bangles are engraved short and pertinent quotations from the great William's dramas. Frank H. La Pierre, 18 East 14th street, New York, is the manufacturer. An attractive little hanger, showing the quotations used in the work, will be sent to dealers upon application.

—In a table extracted from the report of the rating of pocket chronometers in 1888, from the Director of the Observatory of Geneva, published in another portion of this impression, it will be seen that of the eighteen watches submitted to test by the Non-Magnetic Watch Co., one received second prize, one honorable mention and five simple mention, a remarkable showing indeed.

—The experiment of placing upon the market a regulated and reliable cheap nickel clock, which was undertaken by the Western Clock Mfg. Co., of La Salle, Ill., has proved a decided success. It did not take long for the trade to appreciate the advantages to be derived in keeping them in stock. The company intends to bring out in July a larger movement in a five-inch case. The works at La Salle are being enlarged.

—While prospecting at Plattville, near his home at Argyle, Wis., W. H. Penston discovered a substance that was brilliant, extremely hard, it is said being capable of cutting glass, and had fifteen sides. Several jewelers pronounced it to be a diamond. The delusion was dispelled, however, when it was submitted to the critical examination of George F. Kunz, the well-known gem expert, who declared it to be a brilliant crystal of quartz, such as is found in large quantities in Herkimer Co., N. Y.

—On the 18th of March, a mass meeting of the engravers of the agate cutting firms of Idar, Germany, was held, at which stirring speeches were made by the leaders of a movement to join the striking cutters. It was resolved, after a hot discussion to send a committee to the employers to demand 25 per cent. increase of wages. The demand not being acceded to, a general strike was organized. Several of the agate cutting firms have acceded to the demands of the strikers, and the men have returned to work at a 20 per cent. increase of wages.

—The John Foley Pen Co., 18 John street, has moved to 306 Broadway.

—Perhaps as handsome a trade souvenir as it has been our pleasure to behold, was issued last month by the Sterling Company, of Providence. The company is known for its ingenious and beautiful advertising conceits, but the one to which we refer, outrivals all previous efforts. It is a pamphlet containing a history of the firm, quoted from the Providence *Journal*. The binding, paper, letterpress and press work, are the best obtainable. On the cover is stamped a representation of the company's beautiful business card, an elegant photogravure of the works is inserted in the book, and each page is quaintly decorated with colored initials, foot-pieces, etc.

—The erection of the watch factory at Otay, Cal., is progressing rapidly, the brick foundation being completed. The building will be 100x38 feet and three stories high. A number of residence buildings adjacent to the factory to accommodate the workmen engaged from the East are to be constructed. It is expected that the works will be in running order by August, and a force of 200 hands has been engaged to commence with. The section of the country in which the new factory lies, deeply feels the benefit of the proximity of such a works, as besides the welcome addition to the population; the monthly pay roll of the factory will amount to at least \$10,000.

—On March 28, was held the thirtieth annual meeting of the American Waltham Watch Company. The stockholders voted to issue 10000 new shares, thus increasing the capital from \$2,000,000 to \$3,000,000. The present stockholders were given the privilege of subscribing at par, their subscription being payable May 15. The meeting also marking the thirtieth anniversary of the election of Royal E. Robbins as treasurer, this gentleman reviewed the history of the company, and made some pertinent comparisons between the first and last annual reports. At a subsequent meeting of the directors, a cash dividend of 50 per cent out of the surplus was declared payable the 15 of the present month. No changes in the management or directory were made.

—The suit of A. J. Goldstein, of Seneca Falls, N. Y., against J. C. Aikin, of Alkin, Lambert & Co., New York, which had been in the courts for over a year, was decided on April 1, at Syracuse, N. Y., against the plaintiff. It will be remembered that shortly after the failure in 1886 of M. Levy & Co., of Little Falls, Mr. Goldstein was arrested on the charge preferred by the New York creditors of obtaining goods under false pretences. Goldstein was in February, 1888, examined before Judge Smith in the Tombs, New York, and acquitted. Goldstein immediately commenced suit for \$10,000 against Mr. Aikin, who had made the formal complaint before the justice, for malicious prosecution, claiming that he had been arrested and brought to New York, thereby ruining his health and reputation.

—W. F. Nye, the prominent manufacturer of watch and clock oils, will have an exhibit at the Paris Exposition. Any words of commendation for these oils at this late day would appear superfluous. They are taking first place in the estimation of the leading watch and clock manufacturers, and the verdict from numerous critical watch adjusters that they are the "best," is a sufficient testimonial of their merits. Mr. Nye now commands the entire stock of "jaw" and "melon" oil, having recently purchased what has been retained by outside parties from the large school of fish caught in 1884; he is thus prepared to meet the demands of the trade during the next four years. As to the manufacture of watch and clock oils from vegetable or animal substance, Mr. Nye says: "Our 25 years' close observation warrants us in making the assertion that a first-class oil cannot be made from them. We know of no oil suitable for the purposes of a watch or clock oil excepting those made from the head and jaw of the blackfish and porpoise."

—The Alvin Manufacturing Co., of Newark, N. J., has adopted a new method of decorating glass and porcelain surfaces, combining practical utility with beauty of design, which, after a series of experiments, they have brought to a state of perfection. Words can hardly express the exquisite effects thus produced. The article is coated with a heavy deposit of pure silver, and designs are applied in open work to the richly cut or polished surface of the glass or porcelain. The number of useful and at once beautiful objects that can be produced by this process is practically unlimited, and can range from small and inexpensive to large and costly ones. Among the articles of which samples can be displayed, are water bottles and glasses in plain and cut glass, claret pitchers, decanters and glasses in sets to match, several new and handsome designs in toilet perfume bottles, flasks, vinaigrettes, pungents, salad and fruit dishes, finger bowls, salt cellars, besides a large line of small pearl, ivory and tortoise shell novelties decorated in the same manner.

PAILLARD NON-MAGNETIC WATCHES.



No. 45.

15 Jewels, Nickel, Adjusted.



No. 71.

20 Jewels, Nickel, Adjusted.



No. 81.

15 Jewels, Nickel, Adjusted.



No. 47.

15 Jewels, Gilt, Adjusted.



No. 74.

15 Jewels, Nickel, Adjusted.



No. 84.

7 Jewels, Gilt.

ARE MADE IN THE FOLLOWING GRADES:

18 SIZE, FULL PLATE,

AMERICAN MANUFACTURE.

No. 43—15 Jewels, Nickel, Adjusted.
 No. 45—15 “ “ “
 No. 47—15 “ Gilt “

16 SIZE, $\frac{3}{4}$ PLATE.

No. 71—20 Jewels, Nickel, Adjusted.
 No. 72—18 “ “ “
 No. 73—16 “ “ “
 No. 74—15 “ “ “

No. 81—15 Jewels, Nickel, Adjusted.
 No. 82—15 “ Gilt, “
 No. 83—11 “ “
 No. 84— 7 “ “

We invite special attention to the above grades, which can be found with our Special Wholesale Agents.

Very Respectfully,

NON-MAGNETIC WATCH CO., OF AMERICA,

177 BROADWAY, NEW YORK.

—It is reported that an important discovery of agate has been made by one Judge Burns at Kingston, New Mexico. The lode is said to measure 300 feet in length.

—The Fidelity Watch Case Company will move into the Corbin Building, 192 Broadway, early in the present month in order to secure more room than their present office affords. Under the active office management of A. G. Funck, ably seconded by M. Schwitter's long factory experience, the business is advancing with rapid strides.

—Work on the new plant of the Gorham Manufacturing Co., at Elmwood, Providence, is making rapid progress toward completion, and we learn that it is the intention of the company to move thence, at an early date, its wood-working shops in order to increase the present factory facilities for this season's requirements. The order of the silver centennial medals was placed in the hands of the company; the medal is designed by St. Gaudens, and modelled by Phillip Martiny.

—A so-called "star emerald" is being exhibited in a town in New York State. It is of a beautiful green color, is extremely brilliant and has in its center a multi-cornered white star. These peculiar artificial gems are rare, and are formed by the crystallization of pieces of green glass left at the bottom of the glass pots during the time the workmen are on strike, and the formation in the mass of small white crystals, shaped like stars or snowflakes. The mass is cut into ornamental shapes for wear. There was one in the Hope collection, but it was not very beautiful.

—The Columbus Watch Co. has discontinued the manufacture of Nos. 34 and 22, open face watches, and is now disposing of its remaining stock of them. The former is adjusted nickel, gold settings, patent regulator, 15 jewels, and can be furnished with either Roman or Arabic dials as desired; the latter is nickel, 11 jewels, patent regulator and Roman or Arabic dial. All the movements are fully guaranteed and are offered at greatly reduced prices to make room for new high-priced goods. There is only a limited number to be disposed of, so dealers should exert themselves to take advantage of this unusual opportunity of buying salable and good articles at low figures.

—A New York jeweler last month re-set for Mrs. Harrison a quaint old heirloom of the Harrison family in the shape of a brooch. It shows the miniature of a woman in costume of 50 years ago, painted in pastel. There is a faint smile on the shadowy face, which shines out of a grayish halo, and suggests the poetry that surrounds an ancestress, more effectually than a modern photograph can do. A narrow rim of gold surrounds the face, and outside this is a filigree setting studded with small pearls and garnets. The brooch is much too large for present ideas, but would look admirable as a belt clasp or shoulder medallion.

—The factory of the Newark Watch Case Co., 60-62 Arlington street, Newark, of which Henry Lefort is President and Victor Nivois manager, is now in operation and everything is running smoothly. They have a large number of orders on hand for both filled and gold cases. Their filled cases are warranted to contain more gold than any other filled case on the market, and their establishment will be headquarters for novelties in gold cases, Mr. Nivois, the manager, having recently originated the patterns of the Dueber Watch Case Mfg. Co., and being generally recognized as one of the most skilful engravers in the country.

—With this issue of THE CIRCULAR we present to our readers a cut of the new Owings Building in Chicago, to be occupied by one of the most successful watchmakers' schools in this country, the Chicago Horological Institute. Retaining the most talented instructors to be had, and equipped with all that is best and most modern in the way of tools, it is no wonder that this institution has grown to the size it has, and taken its place in the front rank with the horological schools of the world. R. E. Fenner, the head instructor, is one of the best known and most skilful watchmakers in the country, and has been a close student of horology. He is most ably assisted in his duties by M. Einsiedel, of Grossman's school of horology, Glasshütte, Germany, and the whole corps of instructors are men of ability. An institution where practical and theoretical instruction could be had has been a want long felt in this country, and we are glad to record the fact that at last some one has had the enterprise to start such a school and put in the necessary instructors and complete outfit of tools to make it what this has now become—a permanent fixture in the trade; the time has passed when young men are satisfied with a store apprenticeship of three or five years. The watchmaker of to-day must know his art thoroughly to successfully carry it on and retain the confidence of his customers. We expect to see the students of this institution graduate with the highest honors, not only reflecting credit upon themselves but upon the institution, its instructors and its founders.

—S. W. Gould is out of business at Ashland, Kansas.

—Wm. F. Ladd, the well-known Wall street jeweler, has moved to 104 Broadway.

—Julius Lando, optical goods dealer, of Milwaukee, Wis., is contemplating opening a branch store in Omaha, Neb.

—The practice of awarding medals and prizes to the winners of outdoor sports and athletics is gaining more and more popularity every year, and jewelers to whom orders for such goods are usually given should always keep in mind the name of a reliable manufacturer who makes these articles his specialty. E. R. Stockwell, 19 John street, New York, has the facilities for producing any species of such work—prizes for shooting, aquatics, bicycling, base ball, etc. Mr. Stockwell recently filled a contract for 25,000 white metal souvenirs, for the Galveston City Railroad Company. Jewelers receiving inquiries for such orders or for any special medal work, would do well to communicate with this manufacturer.

—During the Exposition recently held at Melbourne, Australia, at which the American Waltham and Non-Magnetic Watch Co.'s had exhibits of non-magnetic watches, question arose as to the similarity of the balance of the watches of these companies. The opinion of an expert, Mr. Kahan, was obtained, and his report is as follows: "I have received from Robert Beevton & Co., agents for the Waltham Watch Company, a non-magnetic watch for the purpose of reporting to you whether the same is identical with those known as Paillard & Co. I have examined No. 3,292,923. Lever escapement, keyless (Riverside). The balance (bi-metallic compensated, hair spring, Breguet), lever pallets and ruby roller are made of such metals that are not liable to become magnetized, and consequently these watches are well adapted for the purpose for which they are made. *The balance and hair spring are not identical with those known as Paillard's.*" This report, together with the following, was sent from the exhibitors, American Waltham Watch Co., to Mr. Ellery, the government astronomer, of Victoria, in consideration of which he recommended that that company be given a first award for their non-magnetic watch: "At first the watch had a gaining rate of thirty minutes per day. After wearing it for some days and finding this rate fairly constant, the watch was used in timing tests or dynamos—the rate then changed to go seconds per day, losing. I then regulated it so as to bring it to a gaining rate of twenty seconds per day. This being constant for six days the watch was again used in the dynamo room and without affecting the rate. I have worn it constantly, and it has been brought several times in contact with dynamos at work, having a magnetic field which I think would have ruined an ordinary movement; but its rate still remains gaining about twenty seconds per day." These statements were sent to the company by Captain Joseph, who carried one of its watches with him while occupied about dynamos in the electric lighting department.

—At the five sittings of the Executive Committee held during the past month, the following have been granted certificates: Louis A. Martin; Robert J. Mills; Walter S. Mills, M. D.; Albert Susstrong; Joseph Moscovitz, Bruttner & Moscovitz; Frederick Boger, *Jewelers' Catalogue*; Edwin F. Skinner, Elgin National Watch Co.; Louis E. Fay, Alling & Co.; Chas. A. Fraser, Riley & French; John W. Brereton, Stern Brothers & Co.; William L. Meerbott, Jr., Ten Eyck W. Rouse; John W. Sherwood, United States Jewelry Company; Henry E. Oppenheimer, H. E. Oppenheimer & Co.; E. H. Fordham, P. & A. Linton; Walter Jessop, C. Sullivan; Rudolph Ceyers, Richard C. Pennock; William C. Lucas, Alford & Lucas; Samuel E. Turner and Benjamin F. Wollen, D. H. Wickham & Co.; Clinton R. Fisher, Henry Clews & Co.; Moses H. Landman, Salomon Davidson; Chas. L. Krugler, Krugler, Kimball & Co.; Nathan Rosenbaum; William L. Vennard; Fred'k D. Ilgen, Aikin, Lambert & Co.; and Theo. H. Schulz; all of these are of New York City. John W. Poe, M. Eisenstadt Jewelry Company, St. Louis, Mo.; Peter Blake, Benjamin J. Hill, William H. Hamilton and Adam Kessell, Brooklyn, N. Y.; Alfred H. Driggs, Theo. M. Favre, Joseph Shopp and Lawrence Westerlund, Jersey City, N. J.; John H. Schofield, Richard L. Bohannon, M. D., Frederick W. Stadler and Frederick W. Tegtmeyer, Stamford, Conn.; Stephen D. Ferris, Five Mile River, Conn.; Arthur S. Ferris, George Olley, with Arthur S. Ferris, and Arthur N. Clark, M. D., South Norwalk, Conn.; Herman Lockstaedt, Union N. J.; Edward H. Eckfeldt, Kerr & Battin, Newark, N. J.; Alfred W. Lawton, Bergen Point, N. J.; William M. McDougall East Orange, N. J.; Cornelius Schoenfeld, Hoboken, N. J.

Additional examining surgeons have been recently appointed as follows: For Jersey City, N. J., Dr. John Nevin, 137 Wayne street; South Norwalk, Conn., Dr. A. N. Clark, 51 South Main street; for Stamford, Conn., Dr. R. L. Bohannon, 79 Atlantic street; for Brooklyn, E. D., N. Y., Dr. Jas. W. E. Roby, 115 Lee Avenue; for Harlem, N. Y. City, Dr. Walter Sands Mills, 415 East 116th street.

TABLE OF CONTENTS.

A Complete History of Watch and Clock Making in America.....	28	Foreign Gossip.....	78	Master Work, A.....	54	Plated Jewelry of the Future.....	30
Advice to Watchmaker's Apprentices.....	58	Free Hand and Mechanical Drawing.....	48	Mechanical Ocular Defects.....	54	Pendulums.....	47
Atleboros, The.....	37	Glimpses of the Paris Exposition.....	25	Movable Stud, The.....	78	Pallet Lockings.....	70
Center Seconds Chronograph Watch with only one Barrel.....	70	Good Way to Clean a Mainspring, A.....	70	Northwest, The.....	44	Preparing for Wet Coloring.....	74
Chicago Briefs.....	33	Gossip of the Month.....	20	Obituary—William Smith—Charles Downs—Hiram Hotchkiss—William D. Black—Charles Fasoldt—James R. Harper— and James Abbe.....	93	Providence Notes.....	34
Cincinnati Letter.....	34	Improved Poising Tool.....	62	Ohio Association's Annual Meeting, The.....	29	Recent Patents.....	82
Communications.....	81	In the South.....	44	Oxidation on Silver.....	42	Remarkable Musical Clock, A.....	74
Electricity and Magnetism.....	61	Japan's New Patent Laws.....	73	Paris Exposition (editorial).....	24	Smuggling Under Difficulties.....	57
Fashions in Jewelry.....	49	Jewelers' and Tradesmen's Company, The.....	38	Paris Gossip.....	41	The Quaker City.....	92
Foreign Matters.....	42	Jewelers' Security Alliance, The.....	38			Trade Gossip.....	85
		Jewelers' League, The.....	93			United States Jewelers' Guild, Meeting of.....	22
		Marfels Watch Collection, The (Illustrated).....	65			Workshop Notes.....	77

INDEX TO ADVERTISERS.

Abyr, Chas. Leo.....	40	Dinkelspiel, S. B. & Co.....	103	Merritt, S. F.....	14	Sheafer, W. H., & Co.....	36
Aikin, Lambert & Co.....	51	Didishelm, Hlpp.....	36	Middletown Plate Co.....	11	Shlebler, George W.....	17, 35
Albro, S. & Co.....	Inside back cover	Dueber Watch Case Mfg. Co.....	10	Miller Bros. & Co.....	27	Simpson, Hall, Miller & Co.....	63
Alvin Mfg. Co.....	40	Edge, W. C. & Sons.....	2	Montgomery & Co.....	103	Smith & Knapp.....	52
American Watch Tool Co.....	60	Evans, W. F. & Sons.....	76	Moore & Horton.....	72	Smith, Alfred H., & Co.....	24A
Ansonia Clock Co.....	1	Fidelity Watch Case Co.....	80	Myers, S. F. & Co.....	80	Smith B. & W. B.....	outside back cover
Anti-Magnetic Shield & Watch Case Co.....	13	Fisher & Sons.....	59	N. Y. Watch Case Spring Co.....	97	Special Notices.....	97
Atkinson Bros.....	67, 75	Floyd, Pratt & Rounds.....	40	New Haven Clock Co.....	51	Spencer Optical Mfg Co.....	7
Bartholomew & Peckham.....	103	Poster & Bailey.....	23	Newman, Louis, Jr.....	103	Sterling (The) Company.....	4
Ball, Wm. H. & Co.....	19	French, J. H.....	76	Newport Aluminum & Steel Co.....	80	Stern & Stern.....	15
Beguelin, Tell A.....	96	Friedlander, R. & L.....	15	New York Standard Watch Co.....	59	Stockwell, E. R.....	40
Bedichlmer, I.....	60	Gorham Mfg. Co.....	20	Nicholson File Co.....	80	Sussfeld, Lorsch & Co.....	46
Berger, Albert & Co.....	12	Hancock, Becker & Co.....	52	Nissen, Ludwig, & Co.....	88	Tannenbaum, L & Co.....	46
Birch, John S., & Co.....	96	Haskell, H. C.....	59	Non-Magnetic Watch Co.....	39	Taylor & Bro.....	36
Blackinton, W. & S.....	31	Hausburg, O. E.....	103	Nye, Wm. F.....	18	Ternend, F.....	103
Blancard & Co.....	71	Hedges, Wm. S. & Co.....	64	Odenheimer & Zimmern.....	104	Thrall, Edwin A.....	71
Bookhout Bros.....	103	Heinrich, H. H.....	60	Oppenheimer Bros. & Velth.....	56	Towle Mfg Co.....	75
Bowden, J. B., & Co.....	27	Howard, S. P.....	Outside back cover	Oppenheimer, Henry E. & Co.....	79	Trenton Watch Co.....	87
Briggs, J. & Sons.....	17	Hyde's Sons John E.....	60	Ostby & Barton.....	32	Troemner, Henry.....	103
Carter, Sloan & Co.....	52	Jacques, Charles.....	40	Owen, G. & S., & Co.....	36	Vallentine & Co.....	71
Buhler & Nanz.....	67	Jeandheur, F. Jr.....	46	Palrpoint Mfg Co.....	15	Van Moppes, D. L.....	103
Bynner, T. B.....	103	Jeannot & Shlebler.....	63	Perclval, D. C., & Co.....	68	Valuable Instruction Books.....	Inside b'k Cover
Carter, Sloan & Co.....	55	Keller, L. H. & Co.....	96	Peterson & Royce.....	67	Wade, D-vis & Co.....	88
Cattelle & Decker.....	67	Kendrick & Davis.....	63	Pforzheimer, Keller & Co.....	59	Wallace, R., Sons Mfg Co.....	79
Chalmers-Spence Co.....	76	Kent & Stanley.....	76	Plainville Stock Co.....	68	Waltham Watch Tool Co.....	14
Cheever, J. G. & Co.....	46	Ketcham & McDougall.....	102	Platt, Chas. S.....	Outside back cover	Want, Edwin.....	19
Chicago Horological Institute.....	2	Koch & Dreyfus.....	32	Prindle & Russell.....	71	Washburn & Moen Mfg. Co.....	103
Clark, A. N.....	76	Kohlbusch, Charles.....	103	Randel, Baremore & Billings.....	84	Watchmaker, Jeweler and Silversmith.....	96
Colby, C. K.....	51	Kremetz & Co.....	95	Richardson, J. W. & Co.....	13	Waterbury Clock Co.....	1
Columbus Watch Co.....	27	Lady Raelne Chatelaine Watch.....	46	Riley, John A.....	56	Waterbury Watch Co.....	91
Conover, D. F. & Co.....	19	Laurencot, J. B.....	Inside Back Cover	Robert, J. Eugene, & Co.....	63	Wheeler, Hayden W. & Co.....	52
Cooke, B. J's. Sons.....	60	Lawson & Van Winkle.....	19	Rogers & Bro.....	9	Whiting, F. M. & Co.....	88
Crescent Watch Case Co.....	45	Lclong, L. & Bro.....	outside back cover	Russell, Chas. A. & Co.....	Inside back cover	Wiesbauer Mfg. Co.....	72
Cross & Beguelin.....	17	Logan, A. J.....	104	Russell, Irving L.....	59	Wilkinson, C. B.....	103
Crossin & Tucker.....	31	Lorsch, Albert, & Co.....	Outside back cover	Sauter, L. & Co.....	36	Woglom, Gilbert T.....	72
Cottler, C. & Son.....	103	Manhattan Watch Co.....	95	Schleicher, Schumm & Co.....	72	Wood & Hughes.....	36
Crouch & Fitzgerald.....	Outside back cover	Mathey Bros., Mathez & Co.....	14	Scott, J. T. & Co.....	6	Wood, Chas. F.....	71
Cuppla, L. A.....	75	McCall & Newman.....	72	Seth Thomas Clock Co., Inside front cvr & 3		Wood, J. R., & Son.....	103
Day & Clark.....	12	Meriden Britannia Co.....	16	Sexton Bros. & Washburn.....	18	Zineman, M. & Bro.....	46

THE
ANTI-SWEAR
CUFF BUTTON.

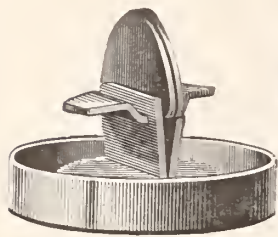

OPEN.

(AUTOMATIC.)



CLOSED.

We are the SOLE MANUFACTURERS of these buttons, the action of which is entirely new and different from any other in the market. Some of its advantages are as follows:

FIRST.—It is the only button having a regular shoe which closes itself automatically when inserted in the cuff and opens itself when taken out.

SECOND.—It has short posts so that it will not rattle or shake in the cuff, but holds it firmly.

THIRD.—There are no steel or composition springs to get out of order.

FOURTH.—We propose to sell them **ONLY TO THE RETAIL JEWELRY TRADE**, and thereby prevent ruinous competition from Dry Goods, Millinery or other outside trade.

FIFTH.—We warrant every pair, and can also put these actions on any buttons at about the same cost as the regular lever backs.

A full assortment in stock in Rolled Plate, Gold Front and Gold.

Orders for Selection Packages solicited.

We also call attention to our

“LEADER”
 SPLIT SECOND, OPEN FACE,

In Silver, Gold Filled, and 14k.

THE LOWEST PRICE SPLIT SECOND WATCH IN THE MARKET.

—ALSO, A FULL LINE OF—

Waltham and Swiss Plain Chronographs

In Gold, Silver and Filled.

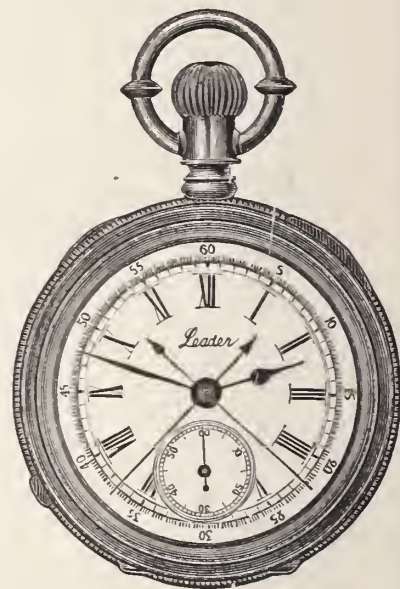

We are also manufacturers of the



Complete Ring.

“SUCCESS”

INTERCHANGEABLE INITIAL RINGS,

of which we carry a large assortment of styles in stock and can fill orders at short notice.



Part of Prong Exposed.

—ALSO,—

Importers and Jobbers of all kinds of American and Swiss Watches, Jewelry, Chains, etc.

Including a large stock of **DIAMONDS**, mounted and loose.

J. T. SCOTT & CO.,

4 MAIDEN LANE, NEW YORK.



THE JEWELERS' CIRCULAR

AND

HOROLOGICAL REVIEW.

OFFICIAL REPRESENTATIVE OF THE JEWELERS' LEAGUE, THE NEW YORK JEWELERS' BOARD OF TRADE, AND THE JEWELERS' SECURITY ALLIANCE.

It is also the Recognized Exponent of Trade Interests.

A MONTHLY JOURNAL DEVOTED TO THE INTERESTS OF WATCHMAKERS JEWELERS, SILVERSMITHS, ELECTRO-PLATE MANUFACTURERS, AND THOSE ENGAGED IN THE KINDRED BRANCHES OF ART INDUSTRY.

SUBSCRIPTION.—To all parts of the United States and Canada, \$2.00 per Annum, Postage Paid. To all Foreign Countries, \$3.00 per Annum, Prepaid.

All communications should be addressed to

THE JEWELERS' CIRCULAR PUBLISHING CO.,
189 BROADWAY, NEW YORK.

Advertising rates made known on application.



A full Index to Advertisements and Table of Contents will be found on Page 5 of this issue.

WE WOULD direct the attention of every reader of THE CIRCULAR to the communication of J. W. Hall, which we have the pleasure of publishing in this issue. It strikes at the very root of one of the greatest evils that afflict the jewelry trade to-day—deterioration in the quality of goods sold and the consequent loss of reputation among the legitimate trade. "The world is still deceived with ornament," and we fear that some of the retail trade have made the mistake of becoming a party to the deception. Mistake, we say, for it is a false and short-sighted policy in the retailer to imagine that by sharing a little larger profit from an inferior article he is the gainer. Quite the reverse. He jeopardizes his own good name and that of his craft, and perseverance in such a course cannot fail to injure his business. A dissatisfied or defrauded customer will cost a dealer many profits before he is through with him. Is it to be wondered at that jewelry becomes unpopular when the jeweler is content to sell "snide" trumpery that is fit only for a bargain counter? There is a legitimate demand for plated jewelry and filled cases, but this demand should be met with reliable goods and not with stuff that can be sold only on misrepresentation. If the jeweler would meet the competition of the dry goods and notions trade on the

proper vantage ground, then let him take high ground and not descend to their level. He should be enterprising and study their arts of drawing custom, but not foolishly sacrifice his reputation and experience, which are his chief strength. The remedy for this evil lies in the hands of the retail trade. They must determine to handle only such goods as they can warrant. This will necessitate a more careful examination of the manufacturers' goods than is commonly given, and a preference in patronage for those who are accustomed to stamp their goods and hence have reputations to lose. The retailer comes in direct contact with the consumer, who holds him responsible for the quality of goods purchased. This responsibility cannot possibly be shifted to the manufacturer. We repeat, the retail trade must protect themselves and their customers from the impositions of careless or unscrupulous manufacturers.

* * * * *

Look at "The Plated Jewelry of the Future," on page 30, then read the communication of J. W. Hall, on page 81, and ponder well their meaning.

* * * * *

THE admirable essay read by Mrs. J. H. Purdy, editor of the *Chicago Jeweler*, before the Ohio Retail Jewelers' Association last month was so replete with intelligent criticism and useful suggestion, that we have reprinted some of the best paragraphs. The emphasis which she laid on the growing demand for purpose in decorative work is illustrated by the increasing popularity of articles of utility that have been beautified by the jeweler. This tendency can not be too carefully observed by the retail jeweler who wishes to keep abreast of the times. What she says about woman's place in the jewelry store is a hint in season, especially to the bachelors of the trade. The advice of an intelligent wife will no doubt help to select patterns suitable to feminine tastes. As to the irresponsible attitude of many on the question of the guarantee we have already expressed our views.

* * * * *

Mrs. Purdy's essay contained some home truths that all ought to reflect on. Vid p. 29.

* * * * *

THE most important question before the American manufacturer to-day, is how to find an outlet for his goods. In the processes of manufacture we stand confessedly the peer of all the world, but in the sale of goods we seem to be deficient as compared with other nations. The Germans, the French and the English, by a more rational tariff policy than ours and a persistent study of the requirements of foreign trade, have stolen a march on us and forestalled us even in the markets of our near neighbors; and now, at this late day, we are just beginning to realize our shortcomings.

The reason why, for so many years, we have neglected our opportunities in this direction is not far to seek. We have had a large and rapidly growing home market to supply, which, until of late years, has been able to absorb about all of our products. This expansiveness of the home market has fostered an impression among our manufacturers that foreign trade does not pay, and is better left for others to do. Orders from foreign ports seldom received the same attention that was given to domestic demands, and no steps were taken to familiarize ourselves with the customs and tastes of those with whom we might have carried on a lucrative trade. And it must be confessed that when our manufactures were yet in their leading strings and the general growth in wealth was greater than it is to-day there was much truth in this view. But we have long outgrown those conditions. Another and less favorable state of things confronts us to-day. Owing to the feverish energy of a new country and the stimulus of excessive protection, manufacturing enterprises have advanced with such rapid strides that our capacity to produce is now greater than our power to consume, and production lags, while on all sides is heard the familiar cry of glut and overproduction. The majority are beginning to see vaguely that we need a wider market for our products. It is in the method to be used in securing that market that the greatest diversity of opinion is found. Some, like the South American Union, recently organized in New York, favor the subsidizing of steamship lines to ply between ours and foreign ports, and the appropriation of bounties by the government to persuade foreigners to trade with us. This policy, if pursued with energy and liberality, would enrich some individuals and might bring good results, but it is roundabout and wasteful. A more sure and speedy remedy is at hand. Let raw materials in free, and then our manufacturers will be able to compete in the markets of the world, and those with whom we wish to exchange will not, as they are now, be so heavily taxed at the Custom House on the products of their labor which they send to us, that trade becomes unprofitable for them. This problem of foreign trade is amazingly simplified if we but remember that it takes two to make a bargain and that except in isolated cases, trade must be mutually advantageous if it is to increase.

* *

* *

* *

The jewelers want reform. Ohio, Minnesota, Pennsylvania, and Iowa say so. See reports of proceedings in this issue.

* *

* *

* *

THE NEW postmaster of New York, Cornelius Van Cott, has been making vigorous efforts at Washington to get a largely increased appropriation to enable him to make the postal service in New York more efficient than it is at present. Many more carriers are wanted to insure prompt delivery of mails to business men, especially in the suburbs. Various other improvements are contemplated, but the necessary funds for their adoption are lacking. The New York post-office contributes a very large portion of the profits of the mail service, and certainly whatever is needed here should be supplied. There is one suggestion, however, that we have never seen noted, which, if adopted, would contribute very greatly to the convenience of business men, and that is the appointment of postal clerks on ocean steamers carrying the mails, similar to the postal clerks now on the railways. At these postal railway offices letters are received up to the moment of the starting of the train. But with the ocean steamers it is very different, while the foreign correspondence of business men with their European customers is quite as important. If one will observe the notice published in the daily papers as to the time of closing the mails for the ocean steamers, it will be seen that the mails close from three to five hours in advance of the time of the sailing of the steamer. If there were a postal clerk on board the steamer who could receive letters up to the moment of sailing, it would be a very great convenience to the business community, and we are surprised that it has not already been

adopted. A single clerk could attend to all this, and sort and distribute his mail during the passage, and have it ready for prompt delivery immediately on the arrival of the steamer at the foreign port. This would give the business community an advantage of several hours in their correspondence, and if it was generally understood that letters would be received on the steamer, a much larger mail could be accumulated for each steamer. We suggest that Postmaster Van Cott take up this subject and give it his matured consideration, and then bring the matter to the attention of the Postmaster General at Washington.

* *

* *

* *

Don't miss a single number of the series treating of "Mechanical Ocular Defects," by Dr. A. C. Bucklin.

* *

* *

* *

THE letter of Margaret F. Sullivan to the *New York Herald*, in reference to the American display at the Paris Exposition, is at once so encouraging to our craft and so intelligently critical of our national defects in the industrial sphere, that we cannot forbear reprinting a portion of it. It reinforces powerfully the editorial comments which were made in our last issue on the new industrial movement for the education of the artist-artizan. After a few pointed remarks on the inferiority of the American decorative sense in general to that of the Europeans, and our evident superiority in mechanical construction, she proceeds to make an exception. She says:

"In decorative treatment of gold, silver and jewels, in etching and enamelling, the American exhibit stands first in simplicity, clearness, elegance and suggestiveness of design, as well as in the ingenuity with which use and beauty are associated. While endless copying of exhausted patterns proceeds in European workshops, the American designer is manifesting discernment in the selection of types worth preserving, and originality and imagination in the creation of new ones possessing the essential traits of beauty. The Tiffany exhibit introduces native ideas of decoration taken frankly from the Indians and developed, presenting a pleasing contrast to British and colonial designing, which is flabbily repeating the feeble, stiff patterns of India, hackneyed at the Indian and Colonial Exhibition three years ago, and worked to subsequent exhaustion at Kensington. In force and individuality, as well as in exquisite manufactures, the Gorham Company stands in front.

Also in the artistic use of plates by electric process the Meriden Company has no visible rival.

The small articles exhibited from the workshops of the Fairchild Company, such as pencils, matchboxes and penholders, are notable for dainty, fancy, durable construction and beauty.

If we have supplied an intelligent world with reading, writing and speaking machines we have also given it the only universal gold pen, but with this brief comment the decorative and industrial art of the United States, impressive in only one great line, comes to an end. It is incredible that we should be content to occupy a relatively insignificant position. The Universal Exposition shows that our path out of it is not untried. England has taken it before our eyes. She sent to artist countries for designers, foremen and trained artisans. She located art museums, and established technical art schools near the centre of her raw materials. She has been educating her labor. Her artizans are acquiring the consciousness of the artist. She sets apart money every year for the art training of labor. We have been doing in a small way involuntary what she had the sagacity to do in a large way under stress of her unconquerable commercial instinct. The American artizan, if given an opportunity, soon distances his alien competitor in originality, keenness and inventiveness. When the educational exhibit can be comparatively considered, it will be found that artistic people begin training the eye when they begin training the mind. The child learns to think with his hands when he begins to think with his head. Decorative manufactures are the most profitable. In the future of American industry, when the training of eye and hand is universally established there will be a natural, beneficent distribution of talent into the various artist crafts. The professions of law and medicine, the counters of merchants, now all overcrowded with under-paid men, will be relieved, and we shall become as independent of foreign countries in the manifold products blending beauty with use as we are now in food supply, fuel, motive power and machinery."

* *

* *

* *

If you don't agree with Mr. Hall, put the difference on paper and mail to us for publication.

Meeting of the United States Jewelers' Guild.

THE United States Jewelers' Guild convened in regular meeting at the Saratoga Hotel, Chicago, on May 8th, and was called to order promptly at 10 o'clock by President Boynton. A quorum was present. Secretary Fox being absent, J. S. Kelley acted in his place.

Office of

WHOLESALE JEWELERS.

Chicago, Ill., May 4, 1889.

MESSRS. FOSTER & BAILEY,

PROVIDENCE, R. I.,

Gentlemen:---Please send at once 1 doz. ea. "Mount Hope" Buttons, 4035, 4081, 4305, 4805, 4806, 4835, 4890, 4891, and ½ doz. ea. of same numbers in your new "Omega" Button. We are having a good many calls for them and would like to try them. Send at once and oblige,

Yours truly,

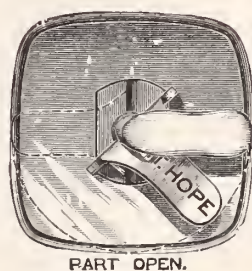
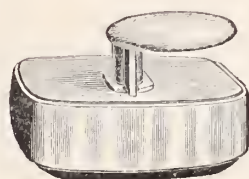
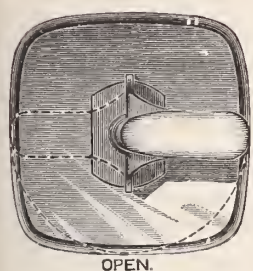

Office of

FOSTER & BAILEY,

Providence, R. I., May 8, 1889.

MESSRS.

, Chicago, Ill.,

Gentlemen:---Your favor of May 4th with order came to hand, and has received prompt attention. As our entire line of "Mount Hope" Buttons are made in the "Omega," you can at any time order the latter from your stock of "Mount Hope" by prefixing "0" to the number. Thanking you for your liberal orders, we are,

Yours very respectfully,

FOSTER & BAILEY.

The following officers were present: W. N. Boynton, S. C. Sisson, O. Startzman. The minutes of the meeting of 1886 and subsequent committee meetings were read and approved, after which the Guild adjourned to meet in the afternoon, when, after two hours discussion, an auditing committee composed of S. C. Sisson, August Burkland, and G. Schurzinger, were appointed by the chair to audit the Secretary's books. On the morning of the 9th the election of officers was taken up, resulting as follows: For president, Oliver O. Startzman, of Iowa City, Iowa; for first vice president, S. M. Bailey, of Uniontown, Pa.; second vice-president, F. H. Huntley, Cadillac, Mich.; secretary and treasurer, Charles J. Olin, Piqua, Ohio. Executive officers: W. N. Boynton, Manchester, Iowa; S. C. Sisson, Covington, Ohio; J. R. Parsons, La-Porte, Ind.; August Burkland, Osage, Kansas; G. Schurzinger, of Wis. All of these officers are elected for the term of three years. The board of trustees chosen consisted of Joseph Welf, Cleveland, Ohio; O. Startzman, Iowa City, Iowa; and J. S. Kelley, Abilene, Kansas—elected for the term of five years.

The contract with the Aurora Watch Co. was renewed for the term of two years, subject to all the conditions and restrictions of previous contracts, with this addition, viz., that the contract shall also be subject to Stock Company formation, as in the contract with the Rockford Silver Plate Co. and J. H. Purdy.

At the evening session the following resolution was adopted:

Resolved: That the Convention indorse the action of the Board of Trustees in making a contract with W. N. Boynton for the manipulation of the Guild stamp, tending to place and keep on the market a more complete line of Guild stamped goods, and that we heartily approve the action taken by Mr. Boynton in the arrangements made for the purpose and distribution of the Guild goods. We also indorse the present co-operative method of raising the necessary funds for conducting the Guild deal; and we hope this move may develop into a strong stock company, wherein each and every member of our Association may have an opportunity to share and share alike.

It was moved and carried that Secretary Olin be appointed to draft resolutions condemning the action of Messrs. Lapp and Fler-shem, in the manner they were guilty of conducting an auction of jewelry at St. Paul, Minn., in March last.

At the morning session Mr. J. H. Purdy was called on to address the Convention in behalf of the Guild for whom he had so long been sole distributor of guild goods, but had resigned, to take effect the 1st of January last. Mr. Purdy said he had not come to address the Convention, but would cheerfully answer any questions they might see fit to ask him. Many questions of minor importance were asked, and promptly answered by him; but when it came to the question of what course he would advise the Association to pursue, he could no longer remain seated. On arising, he said he had always been what they might call a broad gauge worker, and that narrow gauge had never suited his idea of how the best interests of the Guild might be served, and that on account of his liberal and extended ideas he apprehended he had lost some friends in the Guild, but nevertheless he was fully convinced that if he had the power and inclination and wanted to make the most of the situation the Guild has, he would sow it broadcast. He would have a sub-distributor in every city where there was a demand for one, all over the United States.

Professor Fred Purdy, a son of Mr. J. H. Purdy, was invited to repeat his lecture of one year ago on "Magnetism, and How to Demagnetize Watches," but this gentleman was called away on electrical business and did not make his appearance.

In the early part of the meeting it was thought by some that the committee meeting that met in Chicago in January last, had done a bad thing in the distribution they had made of the Guild stamp, but the explanation made by the retiring president was so satisfactory to all that too much could not be said in exoneration of their action.

The following resolution by Mr. Olin was made and adopted:

Resolved: That we in Convention assembled do agree that we will heartily sustain and co-operate with Mr. W. N. Boynton in his new field of operation, and that we will use our untiring efforts to have the entire craft of the United States come forward and assist this cause to the best of their ability, and that we earnestly

desire that every member of the United States Jewelers' Guild shall make an effort to dispose of Guild goods, and in other ways assist the cause.

Resolved, by O. Startzman, That we recommend the *Chicago Jeweler* to guild members as a medium of guild news and guild communications.

After a very pleasant trip to Aurora to visit the Aurora watch factory, through the courtesy of their manager, Mr. J. H. Weber, had been participated in, and the closing hours of the Convention were near, resolutions of thanks and recognition became the order of procedure. The first one of these resolutions to be adopted came in the way of due respect to the retiring president, W. N. Boynton. A vote of thanks was also extended to the retiring secretary, H. E. Fox, for his efficient labor while acting as their secretary; to the Aurora Watch Factory; to Mr. J. H. Weber and Superintendent Johnson; the Saratoga Hotel; the press, and all others that had lent a helping hand. On motion, the Guild adjourned, to meet in Chicago three years from the second Wednesday in May.

* *

* *

* *

Excelsior's articles on Magnetism: continue. Send us your views.

The Paris Exposition.



THE GREAT exposition which is taking place in Paris during the present season is, undoubtedly, one of the grandest exhibits of the industrial and artistic progress made by the nations of the world during the past quarter of a century to be conceived.

The preparations for this exposition have been made upon a very extensive scale, and reports from Paris represent that the buildings have reached satisfactory stages of completion, that the exhibits being sent forward by different nations are numerous and varied, and that the probability is that the exposition will be in good condition at the date announced for the opening. The Centennial Exposition at Philadelphia, by bringing in contrast the products of the genius of different nations gave a great stimulus to the arts and industries of this country, and our manufacturers of to-day are strongly impressed with the ideas obtained at that exposition by our workmen. The Paris Exposition, being of a more general character than any that has occurred since the Philadelphia Exposition, will afford a more magnificent opportunity for contrasting the present condition of the arts, sciences and industries with their former condition, and studying the progress that has been made during a quarter of a century than has occurred since the Philadelphia Exposition. Paris has made every preparation for entertaining an immense number of strangers during the coming season, and all the outgoing steamers are crowded with tourists from this country, who take this occasion to make the tour of Europe and to embrace a lengthy stay in Paris and a study of the exhibits at the exposition. American industry, and especially American art, is very largely represented. The commissioners appointed by the government to superintend the American representation have extended every facility to our people to exhibit the products of their skill and labor, and, as a result, the United States will undoubtedly be more largely represented in Paris than at any exposition that has occurred since that of Philadelphia. Many exhibits of art work in gold, silver and precious stones have already been forwarded, extended notice of most of which will be made in THE CIRCULAR. This exposition at Paris will do more to attract our fellow-citizens than anything else Europe has to offer, and anyone who is proposing to go abroad this season will find himself in the midst of large numbers of our own people and his individual acquaintances. The only difficulty that seems to be presented is that which the steamship companies encounter in providing sufficient accommodations for those who desire to go abroad. We look upon the Paris Exposition as an epoch in the history of the arts and sciences destined to lead in the future to greater development than has ever been known.

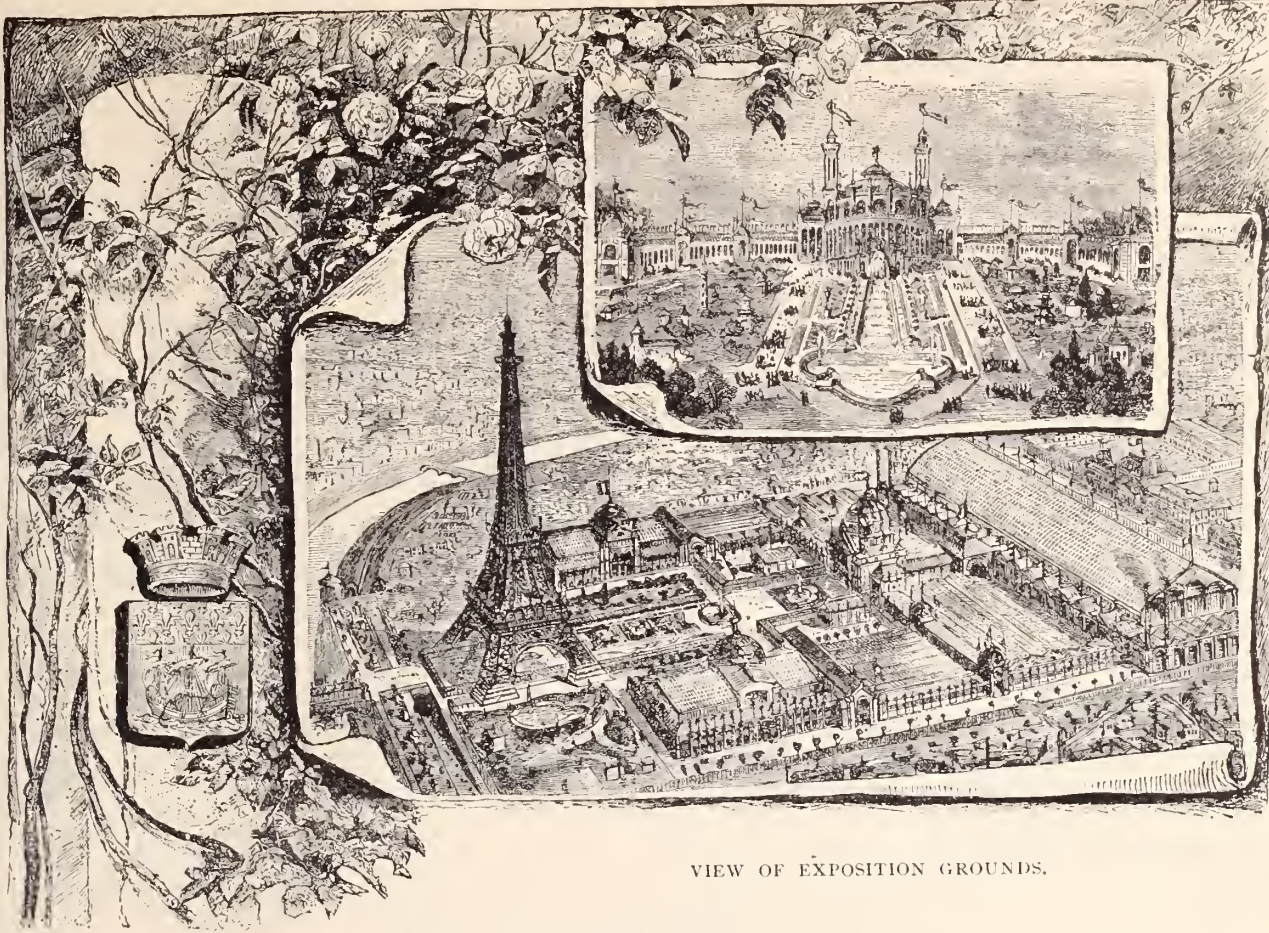

VIEW OF EXPOSITION GROUNDS.

Glimpses of the Exposition.

PARIS, May 5th, 1889.



THIS is written on the eve of the opening day, in the middle of an indescribable excitement. A few sections are prepared and will, perhaps, have received some of their goods by to-morrow morning; but it is now evident that most exhibitors in our lines cannot be ready much before the end of the month. In consequence I can merely offer you a kind of introductory article, in which my personal remarks and observations made (so to speak) behind the scenes, may be completed by some floating rumors and *racontars*.

On entering the Champ-de Mars from the Jena bridge, we are bound to pass underneath the Eiffel tower and have a look at the fountain of Mr. de Saint-Vidal, Carpeaux's pupil. Although of large size, it really does not appear so where it stands, under the iron monster. Eleven figures adorn it, five of which, placed at the base, represent Europe, America, Africa, Asia and Australia, and four are hanging higher up around a globe wrapped up in clouds, which occupies the center of the fountain. One of these personifies History and holds a medalion on which are inscribed the two dates, 1789—1889. The others show us Mercury, Cupid, and the Goddess of Night. Above, mankind, in the shape of a fine woman reclining on the clouded sphere, repels with a dignified gesture the Genius of Light, who has removed her drapery and soars upward brandishing a torch. The ensemble is a very artistic one.

I need not describe to you the Exposition buildings, as, no doubt, several of your periodicals must contain illustrations of them. What particularly strikes one is the metallic appearance of the various colors in all the decorations; on the domes, the statues, the escutcheons, etc. Owing to a happy arrangement of the different hues cleverly harmonized, the polychromy is not at all showy. At least, I did not find it so, although I saw it as it was being done, in that state of glaring freshness which must gradually deaden.

Wonderful is the structure of the *Palais des Machines*, extending right along the back of the central building, and whose architect is Mr. Dutert. The iron frame of this enormous hall looks at once

light, bold and sober. The nave, which is about 1,350 feet long and 375 feet wide, is supported by twenty trusses shooting up from the ground and forming a lowered ogeval arch. The absence of any pillar to prop up the immense roof greatly puzzles people who do not understand the laws of modern architecture. No unnecessary intricacy, no pretense to anything elaborate appears here. All has been perfectly calculated to answer the double purpose of leaving the whole room free and of admitting into it the maximum of light. The effect is one of majestic simplicity.

Every main entrance to each one of the principal sections is decorated with a special character appropriate to the part of the exhibition it leads to. The monumental door which opens on the metallurgic department is supported on each side by columns entirely made of iron and curled at the top into a Corinthian capital. This same metal, alone visible on the sides and at the top, is rolled so as to form a variety of ornaments, in order to show, no doubt, that hardness and durability are not the only qualities of iron which an artistic hand could bend into the most delicate shapes and designs.

The entrance to the section of horology is designed in a very elaborate way, exhibiting all that is suggestive of time or connected with it. On the center of the entablature stands a gigantic hour-glass rising above the broken pediment, in the Henri II. style, and surmounted with a bell. Underneath I see a large clock circled with a garland of flowers. On each side of it is one of those narrow openings in which are placed in a slanting way several pieces of sheet-iron, reminding us of church towers, etc.

The main door of the jewelry department is adorned in a very dainty manner, which borrows something from several favorite styles and especially the Louis Quinze one. The silversmiths' entrance, which is just opposite, in the central hall, is of a very sober appearance, and from its nearness to the gorgeous main cupola is still more severe. The plainness of the round columns, and the old fashioned outlines of the escutcheons, which resemble ancient shields, surmounted with a very simple crown and framed with palm branches, are slightly enlivened by touches of yellow and green gold. The

names of the most celebrated French silversmiths from St. Eloi to Pierre Germain are inscribed along the frontal.

Among the foreign sections, the entrance to the United States department seems to me the most important one. Above the central door are placed the arms, underneath an arch formed by the letters of the words *United States*. Over it two figures, gracefully reclining, one on each side, hold a medallion with the date 1889. Right along the entablature run ten niches in which are inscribed the names with dates of all the Presidents from Washington to Harrison. Great American men in all branches of science from Franklin up to our own days are also mentioned in two other series. All this fronting has been arranged so as to give a serious impression, such as we ought to derive from a history, which, although it only relates facts having occurred in a little more than one century, is full of highly interesting matters connected with progress and civilization.

I should like to give you a description of the artistic jewelry and of the refined pieces in massive silver which will be exhibited in a few days, or maybe in a few weeks; but it would not be an easy task. I have seen many separate parts of those works scattered on benches, but hardly anything in a thorough finished state. When passing, yesterday, through the hall devoted to statuary, I had to wind my way around limbs, heads and trunks of all sizes, lying about on the ground, and I confess that I did not attempt to realize with the help of my imagination how they would look when properly assembled. I think I ought to do the same for those articles which most directly interest us. I shall in my next letter describe to you the most conspicuous pieces. For the present all I can say is that since, in jewelry, the art of reproducing delicate works of nature has been making progress during the last few years, we must be prepared to see flowers, insects and birds made of gems tastefully arranged look still more real than those exhibited in 1878. Perfect wonders in that line are being accomplished by Boucheron, Bapst et Falize, Vever, Fouquet, Rouvenat et Desprez, Teterger, etc., and many will appear, no doubt, in all the foreign sections. If much can be learned in the goldsmith's art from our celebrated ancestors, I think that we can boast of being superior to them in jewelry. Even in the eighteenth century, when highly delicate artists handled gold and silver at will, almost molding it like clay, they never reproduced to a nicety the supple look of leaves and the graceful curves of petals. In that respect, some of their pieces would appear to be a clumsy workmanship to a second-rate jeweler of our time. The ornaments of all kinds, made of grouped jewels, are also more daintily finished in our days. We notice, in the surprising intricacy of some of them, a lightness, a harmony that command the highest admiration.

Parisian exhibitors in the silver line will nearly all invite us to see reproductions of old French styles or free imitations of them. This does not mean that they consider themselves unable to devise something new, but simply that customers will have it so. As real old pieces were getting rarer and rarer, a longing for artistic copies of them began to take possession of our wealthy classes. Mr. Boin-Taburet was the first one who understood the importance of this growing mania, and made the kind of articles well calculated to gratify it. In spite of the strong attachment of his competitors to ornaments made with engine-turning, etching and chasing, they all followed him by degrees, and repoussé became generally adopted. As a consequence, pieces were finished off in oxidized silver, which seemed at the time a most daring revolution. That fashion is far from being exhausted, therefore we must expect to see a great many tea sets, ewers, table services, tête-a-têtes, flower vases, etc., in the old styles, especially the Louis XV. I have seen of that kind some ice shells of a very pretty design. Christoffle & Co.'s important exhibition will show no partiality whatever to one special class of articles. Besides some elaborate works of a large size, they will place in their glass cases their usual run of goods electro-plated and also that the public may have an idea of what they make for daily sale. Most of the other silversmiths will confine themselves to the so-called artistic genre. Among many remarkable pieces in an

unfinished state, I have noticed in M. Boin-Taburet's workshop a stately surtout in the Louis XIV. style. I had also the pleasure of seeing at M. Tebard's shop four candelabra, supported each by a seated figure with emblems, representing the four seasons. They are a part of a large set, including two double fruit dishes of 65 centimeters in width, and a surtout of one meter 15 centimeters, with a female at each end which personify day and night. The whole service in massive silver, also in the Louis XIV. style, amounts to 75,000 francs. Odiot, Froment Meurice and Poussiélgue will show us some veritable master-pieces.

One of the wonders of the Exposition will be, no doubt, Tiffany & Co.'s display, which is going to occupy a large space, and whose surprising variety is described in your April number. I am longing to examine it, and will give you as soon as I can, the impression it will produce on the visitors. The Parisian people, who have seen their exhibit in 1867, still recollect, besides a lovely statuette and a very elegant tea set, two little steamers in silver with ivory parts of a marvellous workmanship; and every one here remembers their brilliant success in 1878, with pieces of so striking a character, obtained by entirely original means. I am also extremely anxious to note the remarks of the many who will linger before the complete collection of American gems, superintended by Mr. George F. Kunz, the distinguished mineralogist.

The Gorham Mfg. Co.'s exhibit is a very important one. I have had the pleasure of seeing Mr. G. H. Houghton, who represents them, and in a few days their display will be arranged in the glass cases. I intend to give a full account of all these pieces, as most of them are remarkable specimens of the silversmiths' art.

Our section of horology will be a very interesting one, especially the exhibits of Claudius Saunier, Rodanet, Paul Garnier, Gustave Sandoz, etc. I have been shown a very curious watch, made by Messrs. Armand Schwob et frères for the Exposition. It belongs to the class of time-pieces called mysterious, being entirely made of glass, with the exception of a silver rim and of the two hands moving as if by some hidden spell. The whole surface is so clear that you could read through it. If you manage to open it the enigma is at once unriddled. You notice between the dial and the back made of plate-glass another glass circle whose outline is hemmed with a metallic rim, divided all round into regular dents. These are set in motion by a mechanism concealed in the top part of the silver margin, slightly wider there and shaped like a crescent. The axis holding the hands is fixed on the middle glass through which it runs both ways, resting on the center of the dial and on that of the plate glass back. The minute hand which turns with the revolving circle, causes the second hand to move, by means of mechanism absolutely microscopic. The whole of it (the watch being shut) is more than a puzzle to the uninitiated.

Now that I have given these personal observations I must come to a few reports which you may find interesting. It is said that a very large pearl of an original color and shape will be seen at the section of French fisheries. It weighs 75 grains and is valued at 75,000 francs.

In the part of the Exhibition devoted to collections of ancient tools, instruments and implements of all kinds, there will be made a rehabilitation of two old work shops. One of them will show us Thomas Germain's shop, with the real sign hanging outside. This will be lent by M. G. Bapst, whose very accurate book on *the Germains* will also greatly help to make the place as it must have been towards 1740. A portrait of the illustrious silversmith, painted by Largillière, and which belongs to M. Odiot, will prove very useful, if Thomas Germain is represented at his bench, as intended. M. Duhamel, President of the Jewelers' and Silversmiths' Society, has been asked by Colonel Laussedat, Director of the *Arts et Metiers*, to procure a few old tools, in which he has fully succeeded, and M. Boin has promised to lend some Louis Quinze pieces in various stages of execution.

It is reported that the total value of the exhibits in the section of jewelry, will be about forty million francs.

J. B. BOWDEN & CO.,

On or before June 1st, will occupy their
new office in

THE CORBIN BUILDING,

Broadway and John St., New York.

★

Sleeve Buttons,
Sleeve Links, Studs,
Collar Buttons, Bangles,
Finger Rings,
Charms.

★

MILLER BROS. & CO.,

37 Union Square,
:: NEW YORK. ::

Factory: 49 FRANKLIN ST., NEWARK.

★

Lace Pins,
Brooches, Locketts,
Medallions, Scarf Pins, Hair
Pins, Buttoners, etc.,
in 14-k. Solid
Gold.

★

INITIAL GOODS A SPECIALTY.

DISCONTINUED.



No. 27.—Open Lever Set.

Nos. 27, 34, 22 and 21,

OPEN FACE LEVER SET,

With Roman or Arabic Dials, as desired.

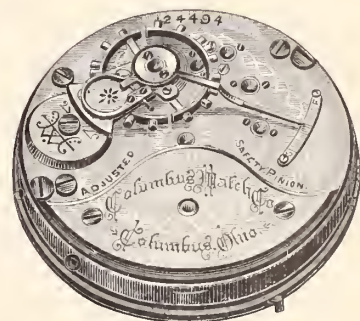

No. 34.—Open Lever Set.

EVERY MOVEMENT FULLY GUARANTEED.

These Movements are offered at greatly reduced prices to make room for new
Pendant Set. **A limited number only** to be disposed of.

FOR SALE BY WHOLESALE DEALERS.

COLUMBUS WATCH CO.



* A Complete History of Watch and Clock Making in America.

[By CHAS. S. CROSSMAN.]

Number Thirty-Four.

Continued from page 26, May, 1889.

WATCH CASE MAKING.

PERRET & MATHEY.



LOUIS MATHEY came to New York in 1814 at the age of twenty-one years, after having served his apprenticeship at the casemaker's trade in Locle, Switzerland. The ship he came over in was wrecked and he lost his tools. He entered the employ of Mr. Perret, the largest casemaker in New York at that time, and during his leisure time made the necessary tools to start business with, which he commenced on the southeast corner of John and Gold streets in 1825. Previous, however, to going into business, he had, besides making his tools, made several trips through the country selling watches. He was probably assisted in making his tools by Mr. Perret.

After a little time he took into partnership Mr. Francis Dubois, and later, in 1837, the firm began the importation of Swiss watches. Mr. Dubois did the engine turning. In 1839 the firm dissolved, Mr. Mathey going to Switzerland, and the business was sold to his nephew, Edward Jacot, and George Courvoisier. They removed in 1842 to 119 Fulton street. At the expiration of seven years Mr. Mathey returned from Europe and re-entered the firm, which now became Jacot, Courvoisier & Company. By this time the principal business of the firm had become the importation of Swiss watches. In 1856 Mr. Jacot withdrew from the firm and returned to Europe. Louis Mathey, Jr., was taken into the firm, Mr. Mathey, Sr., retiring from the business. The firm was now Courvoisier & Mathey.

Mr. Courvoisier died in 1857, and the vacancy was filled by his son, Ulysses Courvoisier, until 1860, when he withdrew to represent the firm of Lutz Brothers in New York, and August Mathey, a brother of Louis, Jr., came in, and the firm became Mathey Brothers. The new partner was a practical casemaker and took charge of this branch of their business. They continued to manufacture gold watch cases until 1880, when they disposed of their case factory to Courvoisier & Wilcox and moved to Maiden Lane, where they have since given their entire attention to the importation of fine and complicated watches. Louis Mathey, Sr., died in 1873 at eighty-three years of age.

ULYSSUS SAVOYE.

Ulyssus Savoye was born in France in 1811. He was an engine turner by trade, and at the age of 17 came to this country to succeed Edward Perret, who was engaged in business in Rose street, New York. In 1845 he moved to West Hoboken, where he remained until he went out of business in 1856. He made English and Swiss cases.

JAMES M. DURAND AND DURAND & CO.

This business was founded by James M. Durand, who served his

apprenticeship with a Mr. Young, who commenced to make cases in a small way in John street, New York City, in 1828. In 1834 Mr. Durand, being then twenty-one years of age, associated himself with his uncle, Silas Durand, who started a machine shop at Irvington, New Jersey, and they made cases there for a year or more. But Silas Durand was a bank note engraver and inventor, and could not give his entire attention to the business, and it was finally swamped in the panic of 1836.

James M. Durand then went to Newark, New Jersey, and associated himself with Taylor & Baldwin, the pioneer manufacturing jewelers, and added a case making branch to their business. He remained a member of the firm until 1840, when he withdrew and started in a small factory making gold watch cases only. He afterwards commenced the manufacture of jewelry.

The firm subsequently became Durand, Carter & Co., from 1850 to 1855, but from the latter date until he retired from business in 1880, at the age of seventy years he had no partners excepting members of his family. It may be said of his production in the case line that they have always been of the highest class of workmanship, and of new and original design. Probably no case manufacturer in this country has done so much in the matter of producing really artistic work in gold cases as Mr. Durand.

The present firm of Durand & Co., which is composed of Wickliffe B. and Wallace Durand and James G. Ward, succeeded him in 1880, and they are keeping up the same high standard of workmanship in the case making as well as in other branches of their business.

WILMARTH, MOFFAT & CURTIS, AND E. TRACY

Were general jewelers, located at 68 Spring street, corner Crosby. They were the first to make watch cases to any great extent in New York City, confining themselves principally to 18-k. old-fashioned English cases. They employed several pencil makers and jewelers, and two brothers by the name of Schuvelts, and Mr. Buckos. John White, of 64 Nassau street, and Chas. A. Hulse were two of their first apprentices. In 1842 they removed to 17 John street, and Mr. Moffat soon afterward went to California for a license from the government to coin money. Mr. Bowman succeeded him, and Mr. Everts, their bookkeeper, came into the firm in 1845. They dissolved partnership in 1850, Mr. Everts retiring, Mr. Bowman continuing the manufacture of locket, jewelry and cases. He gave up the latter branch in 1857.

NEW YORK GOLD WATCH CASE CO.

The New York Gold Watch Case Co. was established in 1842 by William August Guinand, at 173 Broadway. He remained there until his death in 1878, when he was succeeded by his son-in-law, F. A. Jeanneret. Mr. Jeanneret carried on the business for six years and then sold it to Victor Nivois, who took into partnership William and A. S. Herzog, and adopted the name, the New York Gold Watch Case Company. The Messrs. Herzog withdrew after a partnership connection of three years, and Leopold Stern, of Stern Bros. & Co., took an interest, the name of the company remaining unchanged. In 1888 the entire plant at 117 and 119 Nassau street was bought out by the Dueber Watch Case Company, and Mr. Nivois entered their employ for a time, resigning to become connected with the Newark Watch Case Company, a concern recently organized at 60-62 Arlington street, Newark, N. J. They manufacture both gold and filled cases, and have facilities for employing a large number of hands.

LOUIS EUGENE GLATZ.

Louis Eugene Glatz established himself at 42 Beekman street in 1831. He opened with three or four workmen, but his business

men, and was probably the most extensive watch casemaker in the country at that time. He also imported watches, many of them being from his brother, Charles Glatz, of St. Imier, Switzerland. He also imported English watch movements, entirely cased both these and the Swiss movements for the home trade as complete watches. He died in 1863 and was succeeded by his son, Charles Glatz.

HENRY E. DROZ.

Henry E. Droz, now one of the oldest watch casemakers in New York City, went to Switzerland as a young man in 1835 to learn the watch casemaker's trade, and returned in 1837, bringing with him all the tools in use at that time, including an engine turning lathe fitted with the latest improvements. He commenced business at 216 William street in the interest of the firm of E. & J. Droz, of which his father was a member. The principal part of his business consisted in making cases for Swiss movements which the firm imported. He moved in 1845 to 92 Fulton street, his present place of business, and started in his own name. Here he carried on the case business until 1870, when he sold it to the present firm of Henry Goll & Co., 4 and 6 Liberty Place, who make a general line of gold cases for American movements. Mr. Droz himself has since carried on a watch importing and jobbing business at the old stand.

(To be continued.)

The Ohio Association's Annual Meeting.



THE ANNUAL meeting of the Ohio Watchmakers' and Jewelers' Association began on May 14, in the Hollenden Hotel, on Euclid avenue, Cleveland, Ohio. More than 100 members were in attendance. The convention was called to order by President Welf.

Ten applicants for membership were admitted, seven being from Ohio, two of Pittsburgh, Pa., and one of Farmington, Mo. The president reported that he had been in attendance at the United States Jeweler's Guild, which had met during the previous week at Chicago, and that three Ohio Jewelers had been elected to office in that association.

The pool of the association was then discussed, and the books were placed at the disposal of the members for inspection. The convention agreed that the margin on pool goods will be of necessity increased to meet the expenses of traveling agents employed for the distribution of the goods.

The election of officers resulted as follows: President, Henry Welf, Cleveland, O.; 1st Vice-President, A. L. Miller, Malta, O.; 2d Vice-President, W. Horn, Findlay, O.; Secretary, Ed. Lohmeyer, Newport, Ky.; Treasurer, H. Mithoefer, Cincinnati, O.; L. F. Hummel, Cincinnati, O., E. R. Kant and A. D. Ernne, of Cleveland, O., W. Jacobs, of Millersburg, and L. C. Eisenschmidt, of Newport, Ky., were chosen as members of the Executive Board. S. Shott, of Cincinnati, O., A. Thoma, of Piqua, O., and A. C. Collins, of Cleveland, O., were chosen as the Board of Council.

It was decided to hold the next meeting at Dayton, Ohio, on Wednesday, the 13th of November, 1889.

Mrs. M. E. Purdy was pre-ent and read a very interesting essay on "Woman as related to the Jewelry Trade," from which we make the following selections:

"Instead of trying vainly to create a demand for jewelry that is a caricature of ornamentation, turn your attention to supplying the new and growing demand for articles of home adornment and utility, and a class of jewelry that is in harmony with the more delicate sense of beauty of this cultured age. This demand being the outgrowth of a higher ideal of the beautiful, and in perfect accordance with the best and truest sentiments, is in no danger of waning and leaving you with an overstock of unsalable goods. We hear and read much about the caprice of fashion; but if we carefully observe the phenomena of fashion's changes, it will be found that there is an underlying commonsense reason in much that is called

caprice, and that these changes are often significant of moral and intellectual transitions.

That many are awakening to a sense of these changed conditions is evidenced by the almost endless variety of articles now found in jewelry stores that are called innovations, articles that are made to ornament the home, the boudoir, the library, the dining room; articles of personal utility, such as umbrellas and canes, with beautifully wrought handles in silver and gold, handles of brushes, etc., leather goods of every description with silver trimmings, picture frames; elegantly bound books with silver corners and clasps. These beautiful accessories to home adornment furnish ample scope for the skill of the silversmith, and open a field of enterprise which the jeweler is entering largely in the cities. The increasing favor that table silver is obtaining accords with the finer sentiments, as it makes bright and attractive the table around which we gather the home and social circle; and so it will be found in the entire range of ornamentation adopted by intelligent men and women, it is the outward manifestation of inward character. Take up any trade paper you will, in England or America, and you will find a universal agreement that the better class and neater styles of jewelry are growing in favor, while showy and meaningless articles are scarcely called for.

Allow me to throw in a suggestion, which I trust you will take kindly, even if you do not give it your assent. It is the advantage you may gain by employing the talent that woman possesses in your business. No one can interpret the taste of woman like one of her own sex; and however you may pride yourself on your acumen in that direction, the fact remains that very few men should ever undertake to select ornaments for a woman to wear.

If you have a wife who is qualified with just ordinary talent and possesses taste sufficient to dress herself well, let her select your jewelry; educate her in your business and encourage her to take an interest in all that concerns you financially. It is really just as much her interest as your own, and you may by developing her talents discover in her a treasure of financial gain. Marriage would less frequently prove a failure if wives more thoroughly understood and sympathized with the business pursuits of their husbands; and the jewelry business being so peculiarly suited to womanly capabilities, it is a fruitful field in which to develop her genius and secure to you a partner whose interests are identical with your own.

Much has been said by Col. Ingersoll and others about the mistakes of Moses, but none of them have ever mentioned the greatest mistake that Moses made; it was in omitting from his code of morals a separate and distinct list of duties to govern the jewelry trade, for it has been demonstrated repeatedly that there is nothing in the decalogue that fits their case specifically, and the moral obtuseness of a large portion of the craft is such that unless a written contract with ample specifications is drawn up between man and man, they do not recognize any moral obligations.

Strange, too, that Moses should have overlooked this when the first trouble he had after coming down Mount Sinai was on account of the jewelers. It is a study in moral science to observe that in the long line of succession from that far off time to the present day the same spirit has been preserved in this unique craft, for we read that "Moses said unto Aaron, what did these people unto thee that thou hast brought so great a sin upon them?" And Aaron said: "Let not the anger of my Lord wax hot; thou knowest the people that they are set on mischief. For they said unto me make us Gods which shall go before us, for as for this Moses, the man that brought us up out of the land of Egypt, we wot not what has become of him; and I said unto them, whosoever that hath gold let him break it off. So they gave it me, then I cast it into the fire and there came out this calf."

"Thus you see the origin of the grounds of justification that are in use at the present day. 'the people are set on mischief.'

We only supply the demand and furnish what the people want; they do not want honest goods, but will go out of their way to be humbugged.

We receive an order for 10-k. goods to be marked 18-k., and we simply fill it. It is not our province to keep the conscience of those who distribute. We manufacture the goods that are wanted, and after they leave our hands we have no jurisdiction over them.

So the manufacturer is perfectly innocent, and all the responsibility for the demoralization of the trade falls back upon the retailers and the calf they clamored for; this calf for which the trade have sacrificed their gold, their liberty and independence; this God that goes before them, that the manufacturer bows down and worships, and the sad thing about it is that so many of the people say amen (when we say people here we mean the retail jeweler), the people who are the consumers know and care nothing about all the tumult that is going on in the camp of the Israelites.

This golden calf dictates terms to the manufacturer till he dare not claim to have a soul of his own, and the most pitiable sight that the trade has to witness is the spectacle of the retail jewelers carrying this calf on their shoulders."

In Wednesday's session, which was secret, secretary Olin explained the action of the United States Jewelers' Guild and Pool, and numerous addresses were delivered in the discussion which followed.

On Thursday a large number of the jewelers in attendance accepted the invitation extended them by Mr. Dueber, and went to Canton. After dinner at the Hurford Hotel, the party were taken to the Dueber and Hampden factories, where they spent the afternoon in looking through those works. The party, headed by Henry Welf, consisted of A. L. Miller, Malta; John B. Smith, Union City, Indiana; Ed. G. Lohmyer, Newport, Ky.; C. M. Davis, Gallion; E. R. Kant, New York; J. A. Marx, Cleveland; F. H. Kramer, Cleveland; Henry A. Dodt, Cincinnati; D. W. Smith, Alliance; A. D. Erme, Cleveland; C. H. Fuller, Cleveland; Henry Terheyden, Pittsburgh; J. W. Jaengling, Cleveland; Louis Uhl, Cleveland; Chas. A. Eich, Cincinnati; Miss F. A. Warner, Cleveland; Mrs. J. H. Purdy, Chicago; Joseph Welf, Cleveland; H. H. Mithoefer, Cincinnati; N. L. Marsh, Bellaire, Ohio; A. C. Collins and wife, Cleveland; E. Schopp, Cincinnati; Samuel B. Duncan, Cincinnati.

PLATED JEWELRY OF THE FUTURE.



PLATE CHAIN

GETTING ON THE WESTERN TRIP

PINS - THE WAY AROUND

PLATING PROCESS

SOLDERING A BILL

MINUTE FINISH PLATE JEWELRY
WATERBURY & CO. ESTABLISHED 1850

WATERBURY & CO.



[FROM OUR SPECIAL CORRESPONDENT.]

CHICAGO, May 20, 1889.

May has made a better showing than did April, and Chicago's jobbers of jewelry are in a more contented mood than this time last month, although even then there was not sufficient cause for such grumbling as was indulged in; we all know that beginning with April or May there is never very great activity noticeable in wholesale warerooms, still, as compared with a year ago, May has a better record than the month preceding. Collections are satisfactory, and no failures of any consequence have affected Chicago jobbers during the month.

From now on such jewelers as purpose making an exhibition in the Exposition which is held here annually in the fall, will devote some little time in making plans for their display. For some years past the only one in the trade making an agreeable exhibit has been the Meriden Britannia Co., who will also fit up a booth this year. But they will not be alone, as Spaulding & Co. are already making preparations for a display which shall exceed in originality and richness anything heretofore attempted in this city. Edward Forman is daily making plans for it, and he says that Mr. Spaulding is doing the same thing on the other side of the water. He will return to America in time to elaborate the arrangements, and being, as the representative of this State, in constant attendance at that international display, many of the ideas most successful there will be reproduced in Spaulding & Co.'s exhibit at Chicago's Exposition. Several other firms also announce an intention to secure space.

First of May removals and enlargements have made several pleasant changes in Chicago's jewelry trade. Most prominent among the improvements is that made in both location and size of premises by the Ansonia Clock Co., which, with the Meriden Plate Co., make an imposing front on Wabash avenue. The Geneva Optical Co., in place of their contracted space on a second floor, now have the main floor of No. 23 Washington street, while the factory occupies the upper floors of the same building, with ample light and facilities much increased. Max Young has enlarged his establishment by taking in other rooms on the same floor and tearing out the intervening partitions. The Towle Manufacturing Co. have greatly enlarged and refitted their premises. W. S. & J. B. Wilkinson have also removed their manufactory of jewelry cases and silk case fittings to the corner of Madison street and Michigan avenue, where larger space has been secured, which their increasing business has made necessary.

The Corey's Columbia Watch Co has been incorporated here since our last letter, with capital stock \$25,000, C. A. Corey, R. N. Johnson and G. W. Underwood being the incorporators, with the stated object of manufacturing and selling watches, clocks and jewelry.

The Shurley & Co. Jewelry Manufacturing Company announce their intention of dissolving that corporation.

Treleaven & Co. have given a chattel mortgage for \$1,000.

The sensational report telegraphed from this city to eastern journals during the month of the suspension of work at the Illinois Watch Co.'s factory at Springfield, was without foundation. They have not shut down for an hour, nor is any such thing purposed; the facts of the case being that inasmuch as several departments of the factory had gotten ahead of others, it has been found expedient to stop work in those departments until the accumulated material should be used up, and, of course, this necessitated the temporary laying off of quite a number of hands.

The Blauer Watch Case Co., who by the way have gotten their new factory at Kenosha under way, have sent two specimen watch cases of their make to the Paris Exposition where they will be fitted with

Jurgensen movements. The cases are models of the goldsmith's work.

The Dueber Watch Case Co.'s suit against Lapp & Flershem has been disposed of since last month's letter, to the greater satisfaction of the latter firm than to the watch case company, although a verdict for a nominal amount was rendered in their favor.

A. Serewicz has been appointed in charge of the Chicago office of the Dueber Watch Case Co.

The United States Jewelers' Guild, which was formed several years ago with the avowed purpose of forcing wholesalers to sell to the jewelry trade only, and of doing away with the middlemen, as they termed all the jobbers throughout the country, but which, thus far, has not made very astonishing progress in that direction, held six sessions with closed doors in this city, beginning May 8th. While the secrets of the meetings have been carefully guarded, it is stated that it was resolved to establish a manufactory at Chicago, and that Wm. N. Boynton, of Manchester, Ia., and a brother of A. P. Boynton who has a retail jewelry store on State street, this city, has been appointed the manager.

The daily press here has been brought into disrepute among Chicago jewelers, by *The Tribune*. This paper, which formerly occupied the leading position here, recently devoted a large portion of its space to some statements reflecting on the Elgin Watch Co., and on Mr. Avery personally. It seems that *The Tribune* employs a woman who writes over the signature of Nora Marks, to dish up an occasional morsel of scandalous gossip. This woman endeavored to get into the Elgin factory as an employee, but on being refused she admitted that her mission was to spy out whatever may be made into a sensational story, and was properly enough referred by the superintendent to Mr. Avery at his Chicago office. Mr. Avery in his turn, with the sound business sense for which he is noted, refused to give the opportunity for sensational misrepresentation of the life of the watch company's operatives. By reason of this refusal Nora Marks' employers, *The Tribune*, had to make up a sensation without material. It was headed "Avery's Sore Toe," but is not worth the space in these columns necessary to its reproduction.

The creditors of Bowman & Jefferson, Moline, Ill., have granted them an extension, and they will resume business.

F. E. Morse & Son have joined the Jewelers' Security Alliance.

O. W. Wallis has just returned from New York, where he went to attend the funeral of the late Wm. Smith.

It seems that not a month can pass in which the Chicago jewelry trade does not suffer from thievery of one kind or another. Wm. Paulson is the black sheep of this month, and as the result of the theft of nine watches from M. C. Eppenstein & Co., his employers, he has been sent to the penitentiary at Joliet for a year's sojourn. He was employed by the firm as a watch repairer.

John M. Heany, a jeweler of Berlin, Wis., deserves to become known to the jobbing jewelry trade, by reason of his facetiousness. Heany has a habit, which, doubtless, he thinks remarkably brilliant and witty, of sending back circulars received by him from jobbers whom, for one reason or another, have incurred his displeasure, with his opinion of their establishments scrawled across the address so all the world may read it. Two or three years ago this Heany bought thirteen whole dollars' worth of goods from C. H. Knights & Co, thinking, no doubt, that this enormous purchase placed the firm under such obligations to him that he could take his own time in paying for them. It was a good many months before Messrs. Knights & Co. saw their money, and then the major portion of it had been eaten up by the cost of its collection through attorneys. At intervals since that time, one circular from each lot sent out has come flying back through the mail with the words "snide house" and other expressions rather too startling to appear on the pages of THE CIRCULAR. Who it was that regularly returned these circulars, Messrs. Knights & Co. could not determine until a few weeks since they verified their suspicions by sending one to Heany peculiarly marked,

and thus it happens that Heany's heathenish practices are made known for the guidance of other jobbers.

F. E. Morse, of Morse, Mitchell & Williams, has just returned from a trip through Detroit, Cleveland, Cincinnati, St. Louis, Kansas City, St. Joseph and Omaha; in each of these cities the jewelers invariably stated that trade was dull and they would therefore buy but little, but each one of them when asked to compare his present trade with last year's figures, did so willingly and were in nearly every case surprised to find that this blossoming year of A. D., 1889, was quite a way in advance. Every straw your observer notices shows that trade is better than this time last year. Asked for the experience of his own firm Mr. Morse showed the figures in his sales record to prove that from January 1st to May 1st their sales were \$11,000 ahead of the same months last year, and that up to to-day (May 20th) this month's sales equal the entire month of May, 1888.

H. G. Peck, manager of the Waterbury Clock Company, has a sales record proving that the first five months of this year have rounded up a greater sum total than these same months did last year, and there is no question that trade is fully up to the average of this season.

The following are amongst the more prominent jewelers who have visited this market recently: August Buckland, Osage, Kas.; Josten & McGuire, Clarinda, Ia.; H. H. Hunter, Bloomington, Ill.; M. S. Stimson, Dallas, Texas; Oseas Rose, Crown Point, Ind.; J. B. Furgerson, Brownsville, Ill.; E. B. Sunberg, Fargo, Dak.; F. H. Huntley, Cadillac, Mich.; Carl Osterle, Joliet, Ill.; A. H. Nichols, Dowagiac, Mich.; E. Trask, Aurora, Ill., and H. C. Koppage, Racine, Wis.

THE CIRCULAR'S OBSERVER.

CINCINNATI

[FROM OUR SPECIAL CORRESPONDENT.]

CINCINNATI, May 19, 1889.

The weather in this latitude in this, the middle of May, is abnormally hot. The heat of May, 1889, is the heat of July in ordinary years. I think this condition of affairs may have something to do with the dulness in the retail jewelry trade. If the old Roman custom of wearing rings of a certain weight in winter and of a much lighter weight in summer were in vogue here retail dealers would have no cause for complaint. Everybody would be in a big hurry to move into their summer rings. The dulness in retail trade has the sympathy of the wholesale dealers to a certain extent, and the wholesalers, therefore, are not over busy.

A. & J. Plaut, who formerly occupied limited quarters in the Arcade, have just opened an extensive establishment at 131 West Fourth street. Their new quarters are six or eight times as large as their old ones, and are very handsomely fitted up.

The enterprising firm of Oskamp & Nolting have enough faith in the immediate future of their business to put three new men on the road, who have just started out with cases in hand.

R. H. Galbreath, head of the firm of Duhme & Co., is in Europe looking up all of the latest novelties in his line.

There are in Newport, just across the river from this city, two large buildings advertised for sale or for rent. One of them is on Washington street, is 200 feet long by 200 feet deep; the other is on Jefferson street, and is 300 feet long and at least 100 feet deep. They are the buildings which the great Dueber Watch Case Manufacturing Co. have made famous. Before a month rolls around they will be

vacant, the machinery and all the busy hands employed there will have been transported to Canton, Ohio. The company have made elaborate arrangements for the comfort of their employees in Canton. In the first place, by signing an agreement to stay with the company for a year each workman has all the moving expenses of himself and family paid by the company. In addition to this each workman has a house put up for him by the company, and the rent of it goes toward paying for it, so that in the end each workman will own his own home.

Besides their watch case manufactory the Dueber Co. now control the Hampden movement, and will manufacture that at Canton in connection with their watch case business. Indeed, it is generally understood that the acquirement of this Hampden movement is what precipitated the withdrawal of this great industry from the city of Newport. The Dueber Co. needed more ground on which to locate a movement factory, and the estate controlling all the ground in the neighborhood of the Dueber works demanded such exorbitant prices that no company sagaciously managed could afford to pay them. As a result, Newport loses a company that now employs altogether about two thousand men, and not less than \$150,000 is sponged off the Newport tax duplicate.

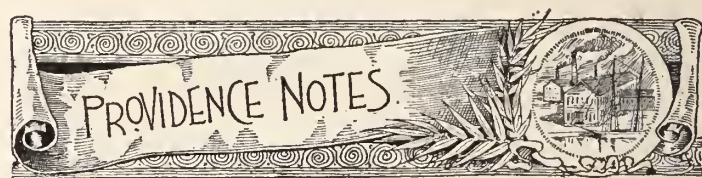

[FROM OUR SPECIAL CORRESPONDENT.]

PROVIDENCE, R. I., May 15, 1889.

The manufacturers are at present worrying their heads in regard to what to place on the market for the fall trade. Many elegant designs will be shown for the first time and should meet with satisfactory sale, judging from their merit. The Centennial celebration at New York closed the spring business sooner than would otherwise have happened. Collections have been very fair during the past month and money easy.

C. Anthony Fowler and family, of Fowler Bros., will spend the coming summer at the "Wentworth," at Portsmouth, N. H., where the blue-fishing is the finest on the Atlantic seaboard, and as Mr. Fowler is a great lover of the sport, he will have ample scope to satisfy himself.

R. A. Kipling, the stone importer, sailed on Saturday, May 11, per the Cunard steamer *Catalonia* from Boston for Liverpool and Paris; he will be away for four months, during which time he will constantly ship to his office in this city large invoices of the latest and choicest novelties which Europe can produce.

Jacob Rosenfeld, formerly connected with Hahn & Co., stone importers, but of late a reporter on the *Evening Telegram*, met with a bad accident on Tuesday afternoon by the fall of the elevator in the Swarts Building on Weybosset street, which resulted in a concussion of the spinal column. He is improving slowly and may possibly recover.

Stephen C. Howard, of Howard & Son, is at present stopping in southern California for the benefit of his health, which had become slightly impaired by close attention to business. He finds the climate of California the finest in the world.

John F. Sipe, of Sipe & Sigler, of Cleveland, Ohio, was in the city the past week buying goods for the firm.

George W. Hutchison, of Hutchison & Huestis, has just returned from a ten days' sojourn down at Rangely Lakes, Maine, where he

caught some very fine specimens of the finny tribe known as salmon-trout and land-locked salmon.

The Foster & Bailey base ball nine, from the factory of Foster & Bailey, were defeated last week by the Riverside Club by a score of 12 to 6.

The monthly meeting of the Directors of the Board of Trade was held at the rooms of the association on Saturday last and was well attended.

Fred. B. Luther's new residence at the corner of Atlantic and Niagara streets is progressing nicely, and will be ready for occupancy late in the fall.

Geo. Wm. Ailman died at Newport on Tuesday of Bright's disease. Mr. Ailman was formerly connected with Tiffany & Co. and the Gorham Manufacturing Co., as head manager in their engraving department.

The following co-partnership notice has been received by the manufacturing jewelers of this city: "Notice is hereby given that the partnership heretofore existing between the undersigned, as wholesale jewelers, and carrying on business in the city of Toronto, under the name, style and firm of Lee & Chillas, has this day been dissolved by mutual consent. The undersigned, Thos. H. Lee, has taken over and will continue the business on the same premises, and all debts due the firm are to be paid to him, and he assumes and will pay all the liabilities of the late firm.

THOS. H. LEE,
GEO. CHILLAS.

Dated at Toronto this 17th day of April, A. D., 1889.

The machinery, tools, office furniture and fixtures of the late firm of Schutz & Co., at No. 38 Friendship street, were closed out at public auction on Saturday, May 4, at 10 A. M., by order of the mortgagee. The prices realized were very low.

Belcher & Loomis, dealers in jewelers' findings, have removed to their new quarters, Nos. 89 and 91 Weybosset street, where they will be happy to welcome all of their old customers, and as many new ones as find it convenient to call on them for they are headquarters.

The Corliss Safe Manufacturing Co. delivered to the Gorham Manufacturing Co. on Wednesday, in Elmwood, a fire-proof door measuring 32x78 inches, for the storage vault the latter company has built in its new works.

S. B. Champlin & Co., have removed from the corner of Eddy street and Friendship to their new building at the corner of Chestnut and Clifford streets, where they have large and elegantly fitted up quarters, fully adequate to their increased business.

Henry Tilden, of Tilden, Thurber & Co., sailed on the 27th ultimo for Havre per steamer *La Bretagne*. He will visit the Paris Exposition, and will travel through England and Germany in the interest of the firm to secure novelties for the coming fall trade, and will return about June 15.

W. H. Ryder, the able representative of the Scovill Manufacturing Co. throughout the States of Rhode Island and Massachusetts, has just recovered from a severe fit of sickness; his many friends are pleased to see him about again.

Hoffman S. Dorchester, Treasurer of the Jewelers' Board of Trade, has been elected one of the Trustees of the Homeopathic Hospital.

George Owen, of the firm of G. & S. Owen & Co., who has been indisposed since the death of his brother, is much improved and is able to be around once more although very weak.

A. B. Day, formerly with C. F. Irons, has commenced business at No. 12 Broad street, under the firm name of A. B. Day & Co. The new firm will make a specialty of society badges, emblems, etc.

Frank W. Davenport has served the manufacturers of this city and vicinity with a notice that the "pigs in clover" puzzle is covered by patent No. 277,120, date of May 8, 1883, held by him, and that all parties manufacturing them without licenses, and all parties handling

goods not marked "Pat. May 8, 1883," make themselves liable under the law.

O. C. Devereux bought at mortgagee's sale on Saturday the pearl business of Chas. L. Potter.

Wm. G. Lawton, with the Gorham Manufacturing Co., has been re-elected Grand Chief Templar of the order of Good Templars of the State of Rhode Island.

Freeman Crowell, late with S. B. Champlin & Co., died of paralysis at his home on the 7th inst.

Wm. M. and John M. Fisher, a committee appointed by the Directors of the Manufacturing Jewelers' Board of Trade to investigate the affairs of Pond, Wilmes & Co., of Kansas City, Mo., have returned home and presented the fruits of their investigation to the Board.

C. A. and J. D. Fowler have just returned from a ten days' fishing trip down at the famous Rangely Lakes, Maine; they brought back some fine salmon-trout, the largest of which weighed about eight pounds each.

The following notice was sent out to the trade during the past month:

Providence, R. I., May 6, 1889.

The undersigned hereby notifies all whom it may concern, that Fred. I. Marcy, individually, and as Fred. I. Marcy & Co., having liquidated all claims against him individually, and as a firm under assignment to me, and such assignment being no longer in force, parties may make payments to, and deal with said Fred. I. Marcy and Fred. I. Marcy & Co., as previous to said assignment.

(Signed) WM. C. GREENE, Assignee.

FAIRFAX.



[FROM OUR SPECIAL CORRESPONDENT.]

ATTLEBORO, May 15, 1889.

During the past thirty days some of the shops have done a large business manufacturing "pigs in clover" charms and novelties, but it would seem from the present indications that those firms who kept out of this business are in luck, as a number of individuals have sprung up to claim a patent on the device, and infringement suits are threatened.

ATTLEBORO.

The controversy over the alleged ownership of the patent on the "pig puzzle," as intimated above, is being watched with much earnestness by a number of the largest firms in town. Very soon after the large toy puzzle began to boom the Bates Button Company started in to make a few samples in imitation of the puzzle, and as soon as they were seen by New York jobbers they received some large orders. They undoubtedly got a good price for the first lot, but other firms "caught on" and orders began to come thicker and faster. In the midst of this boom, Mr. Moses Lyman, of Waverly, N. Y., who claims a patent on the puzzle, stepped in to see what he was to get out of it. One of the firms who had a very large order evidently got scared and stopped, but others kept right on until the market was glutted. Now Mr. Lyman claims a royalty on every charm made, but it seems that he will be obliged to prove his patent as a certain Mr. Davenport, of Providence, has been in town within a few days to put in a prior claim.

W. A. Bigelow, formerly a merchant in town, has been engaged as traveling salesman for the Bates Button Company. It was reported

that he had become a member of the firm but this is not the case.

Sumner Blackinton, manager of the New York office of W. & S. Blackinton, was in town this week.

A party of Attleboro jewelers, among whom are W. G. Clark and C. R. Harris, are spending a week or ten days among the Maine lakes. Great tales are expected on their return.

NORTH ATTLEBORO.

I believe the general tone of business here is somewhat healthier than a month ago. But most of the shops are doing something, and, while not plentiful, orders are still numerous enough to be quite encouraging.

There have been a number of applications for the bankrupt Wamutta house but as yet it has not been opened.

E. I. Franklin & Co. are, as usual, doing a very good business. Mr. Franklin is noted for his fondness for horses, and his stable is an interesting place for a man who is a good judge of horseflesh.

S. E. Fisher has recently been on a business trip to Manitoba.

MENDON.

The Jewelers' and Tradesmen's Company.

GILBERT T. WOGLOM, *President.*

THOMAS A. YOUNG, *1st Vice-Pres.*

SHUBAEL COTTLE, *2d Vice-Pres.*

EPHRAIM S. JOHNSON, JR., *Sec'y.*

SAMUEL W. SAXTON, *Treasurer.*

BOARD OF DIRECTORS.

JAMES A. SMITH,.....M. B. Bryant & Co.
 EPHRAIM S. JOHNSON,.....Treasurer, E. S. Johnson & Co.
 SAMUEL W. SAXTON,.....President Solid Link Chain Mfg. Co.
 CHARLES A. FOWLER,.....Fowler Bros.
 JOHN C. DOWNING,.....Downing & Keller.
 SHUBAEL COTTLE,.....President S. Cottle Company.
 THOMAS A. YOUNG,.....Ex-President National Association of Commercial Travelers ;
 Chair'n Legislative Committee and Vice-President of the Commercial Travelers'
 Asso'n, State of N. Y. ; President Traders' and Travelers' Union.
 CHARLES F. ROBERTS, M. D., *Medical Director*, 69 E. 54th St., N. Y. City.
 SAMUEL A. BALDWIN,.....W. E. White & Co.
 GILBERT T. WOGLOM,.....Gilbert T. Woglom.
 WILLIAM B. KERR,.....Kerr & Battin.
 SAMUEL SONDEHM,.....Brühl Bros. & Co.
Superintendent, BENJAMIN O. LAMPHEAR,
Counsel, JAMES M. HUNT,.....(of Rudd & Hunt) 31 & 33 Pine Street.

The following named have been added to the roll of membership: John S. Allen, of J. S. Allen & Co., Minneapolis, Minn. ; Jos. H. Fanning, of J. H. Fanning & Co., Providence, R. I. ; Geo. C. Ridings, Morris, Ill. ; E. N. Chapman, of Chapman Brothers, Holyoke, Mass. ; Wm. Steel, of Wm. Steel & Son, Albion, Mich. ; James P. Warner, of Warner & Parker, Bridgeport, Conn. ; Henry Ginder, of A. B. Griswold & Co., New Orleans, La. ; Eugene W. Price, of E. E. Barrows Company, Plainville, Mass. ; Moses Schawb, A. G. Schawb & Bro., Cincinnati, Ohio ; Victor S. Merritt, Merritt & Small, Easthampton, Mass. ; George A. Strong, Knoxville, Ia. ; Maxamilian J. Mayer, Appleton, Wis. ; Chas. F. Beckstedt, Rockaway, N. Y. ; William Hüger, of the Hüger Manufacturing Company, Ferd L. Nicolay, Enos Richardson & Co., Newark, N. J. ; Julius W. Hoyt, Oswego Falls, N. Y. ; Paul P. Fleeth, of P. P. Fleeth & Co., La Grange, Ga. ; Elbert R. Niles, Z. R. Niles & Son, Oneida, N. Y. ; Frederick H. Reed, and William C. Reed, Jersey City, N. J. ; Michael O'Keefe, Brooklyn, N. Y. ; Geo. E. Cooke and C. L. Cooke, Clarksville, Tenn.

The following from New York city were admitted: James T. Scott, of James T. Scott & Co. ; Walter S. Williams, of Barstow & Williams ; Edwin F. Crawley, with Adolphe Schwob ; Fernando C. Gleason ; Wm. L. Borland ; Alfred Simons, of Falkenau, Oppenheimer & Co. ; Joseph Wienhold and Edward R. Smith, Jos. Wienhold & Co. ; Louis Kaufman ; Ed. Kaufman ; Frederick B. Clement, Bower Bros ;

William Jennings, of the Lincoln & Bacon Manufacturing Company, and Geo. H. Williamson, of Williamson & Co.

The Jewelers' Security Alliance

President, DAVID C. DODD, JR.

First Vice-President, AUGUSTUS K. SLOAN,.....Of Carter, Sloan & Co.

Second Vice-President, HENRY HAYES,.....Of Brooklyn Watch Case Co.

Third Vice-President, DAVID UNTERMAYER,.....Of Keller & Untermeyer.

Treasurer, CHAS. G. LEWIS,.....Of Randel, Baremore & Billings.

Secretary, GEO. H. HODENPYL,.....Of Hodenpyl & Sons.

EXECUTIVE COMMITTEE.

J. B. BOWDEN, *Chairman*,.....Of J. B. Bowden & Co.

C. G. ALFORD,.....Of C. G. Alford & Co.

N. H. WHITE,.....Of N. H. White.

F. KROEBER,.....Of F. Kroeber Clock Co.

SILAS STUART,.....Of Silas Stuart.

H. H. BUTTS,.....Of H. W. Wheeler & Co.

EXAMINING FINANCE COMMITTEE.

J. P. SNOW,.....Of G. & S. Owen & Co.

HENRY ABBOTT,.....Of Henry Abbott.

For further information, Application Blanks for Membership, By-Laws, etc., Address
 P. O. Box 3277. 170 Broadway, New York.

The Sixth Annual meeting of the Jewelers' Security Alliance was held at their office, 170 Broadway, on Tuesday, May 7th, at 3 P. M. In the absence of the President the meeting was called to order by Vice-President Hayes.

The reading of the minutes of the preceding annual meeting were dispensed with. The report of the Executive Committee was presented showing the past year to have been a prosperous one. The report was accepted, and ordered placed on file.

The Treasurer's report was presented, also the report of the Auditing Committee certifying that everything was as represented. Both were accepted, and ordered placed on file.

Two Amendments to the Constitution were offered changing the wording of Art. IV. and VII. The Amendment was approved. A committee of two was appointed to review and revise the By-Laws, said revision to be offered for acceptance by the members at a special meeting of the Alliance that may be called. Mr. Geo. H. Hodenpyl, and Mr. David C. Dodd, Jr., constitute said committee.

The following officers were elected for the ensuing year :

President, David C. Dodd, Jr. ; first vice-president, A. K. Sloan ; second vice-president, Henry Hayes ; third vice-president, David Untermeyer ; treasurer, Chas. G. Lewis ; secretary, Geo. H. Hodenpyl.

There being three members of the executive committee to be elected, C. G. Alford, N. H. White and H. H. Butts were elected as members of the executive committee, each for a term of two years.

Messrs. J. P. Snow and Henry Abbott were appointed as examining finance committee for the year.

The Alliance expresses its appreciation of the courtesy extended to it by the different trade journals, and for the interest manifested in its welfare.

At the regular monthly meeting of the Executive Committee of the Alliance, held at its office on the 10th of May, there were present President David C. Dodd, Jr., Vice-President A. K. Sloan, Treasurer Chas. G. Lewis, Secretary Geo. H. Hodenpyl, and Messrs. White, Butts and Stuart.

J. B. Bowden was unanimously re-elected Chairman of the Executive Committee.

The following firms were admitted to membership : Charles H. Robie, Williamson, N. Y. ; Spott & Spott, Richmond, Va. ; Howard Tully, Fort Worth, Tex. ; Linde Bros., Newark, N. J. ; John Farrow, Charlotte, N. C. ; J. E. S. Medsger, New Florence, Pa., and F. E. Morse & Son, Chicago, Ill.

PARIS GOSSIP.

[FROM OUR SPECIAL CORRESPONDENT.]

PARIS, May 10, 1889.

The Exhibition is now the one absorbing topic in Paris. Every word uttered seems to refer to it, and every action appears to be done in view of it. Consequently our retailers' imagination is worked up to such a pitch that they actually believe themselves to be exhibitors. The remotest shops of our lively town are being polished and trimmed up as though the most distinguished visitors were expected at every moment to come and take a look at them. Each one endeavors to give a special individuality to his display, arranging it over and over again, until he is absolutely satisfied with the effect.

In the Avenue de l'Opera, the Rue de la Paix and the Palais Royal the leading places aim at a rich, yet sober exhibit, a few choice pieces being offered to the admiring onlooker. Here a splendid necklace is shown in the center of a set whose different parts, such as bracelets, earrings, brooches, etc., are made to match it to a nicety. There a diadem or an aigrette occupies the prominent place. If the show consists of silver goods, it is often a ewer on its plate, or an artistic jug in its basin which forces the attention, this being surrounded by various articles of different sizes and uses, similar in style. Another day a *tete-à-tete* will replace the ewer, etc. All these pieces are generally oxidized.

In the faubourgs, where customers are seldom people of independent means and refined taste, it is clear that the retailer's chief object is to impress the spectators with the absolute belief that he keeps a very large stock. If we look, there, at the jewelry, we notice how scarce the gems are. Most rings, bracelets, earrings, brooches, lockets, etc., crowding behind the pane are of gold or imitation metal. If we turn to silver goods, we see them elbowing each other, all in close lines on straight glass shelves, with a rather stiff symmetry. These articles are generally polished. A great supply of goblets, from the smallest size to the biggest, is found at those shops, as the *bourgeois* and the artisans are very partial to that drinking vessel. Serviette rings, egg cups, carving sets, salad spoons and forks, handles for joints, pastry knives, etc., are sold, too, rather plentifully, as occasional presents or wedding gifts, in those hard working neighborhoods. These goods are placed in cases lined inside with ruffled satin of deep light blue, or of dark red; the outside being made of varnished leather (or simili) bordered with a course of gilt ornaments. The second rate dealers have been obliged to reduce their prices enormously, in order to meet the terrible competition of the great bazaars.

The number of mediums between manufacturers and retailers is gradually decreasing. Among the Parisian *commissionnaires* (factors) those in the export line are not so much to be pitied as the others. Although most of the important firms in foreign countries send agents every year to Paris, he is generally accompanied to the various manufacturing places he wants to go to by a factor who is supposed to bargain for him, and to see afterwards that all the goods ordered are finished off properly and sent to him at the appointed time. As a rule, the foreign purchaser, even if he knows French well, does not believe himself sufficiently acquainted with the ways and habits of Parisian makers to do without the help of a factor. This one, besides, being known in the town, seems to offer more guarantee for a prompt and regular settlement. Everything is for the best, when the middleman really has the interest of the buyer at heart, and is qualified to understand what he wants and where it can be found, as, I daresay, some may do. If, now, we consider the class of factors who deal with France alone, it seems evident that they must find it very hard to make it pay at all. Nearly all manufacturers have travelling agents. Besides, they send albums and catalogues to the

principal shops in every one of the towns. Therefore most retailers know where to find all they want and need not apply for it to a third party. Some of the factors, seeing themselves threatened in their very existence, have come to a determined move. They managed to get goods made for them at a reduced price by workmen established on a small scale, and have thus obtained rather cheap articles; but nothing which might be compared, for the finish and the variety, with the general run of goods to be found at manufacturers. They still retain the custom of second rate shops; but even these are bound to turn from them to the manufacturers, in course of time.

Dr. Chautemps, President of the Paris Town Board visited on the 5th of April, the School of Drawing and Modelling, patronized by The Jewelers' and Silversmiths' *Chambre Syndicale*. He was received by Mr. Boucheron, who, assisted by all the members of the commission of the school, and all the professors, explained to him the organization and the object of it. The influential visitor seemed to take a lively interest in all the details, and was pleased to hear

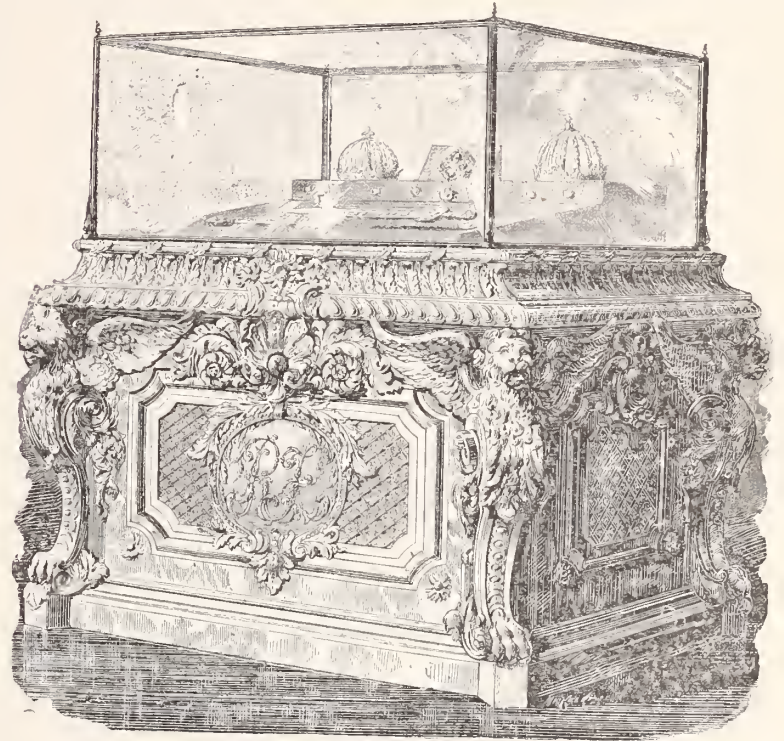

CASE OF CROWN JEWELS.

that, during the last twenty years the School had supplied our trade with 1,800 clever artisans, some of whom have become real artists. Dr. Chautemps was glad to hear that everything had been arranged so that the pupils cannot escape from attending regularly to their duties. They must show to their parents a daily *carte de présence*, and monthly certificates. In taking leave, the president promised to call the special attention of his body to the institution.

The glass case made to receive the crown jewels is finished at last, and occupies a place in the center of the Galerie d'Apollon. It is about four feet long and three feet wide. It rests on a large stand in gilt wood adorned with rich mouldings. On each of the four angles is a handsomely carved lion's head. The initials of the French Republic, slightly linked together show in the center of the two principal sides, and above it shines a sunflower (a symbol of the pagan god to whom that gallery is dedicated). The glorious flower has not been placed there simply as an ornament, but is meant to conceal that point of the mechanism which, being acted upon, sends the cushion with the jewels resting on it sliding down into the iron-coated vault for safe keeping. The beautiful engraving (reproduced above) shows to a nicety all the details of that gorgeous stand, but all the pieces represented are not the crown jewels. I took the trouble to inquire about it at the Louvre, where I learn that a facsimile of Charlemagne's crown and one of Louis XV's with large imitation stones, together with some of the real royal relics, had

been arranged in there temporarily, so as to complete the effect of the illustration.

Happily the fashion of giving Easter eggs has not yet passed away, although it does not seem attended with the same excitement we used to notice a few years back. Two or three weeks before Easter, the purchaser used to visit a great many shops to bargain about the articles that struck him. The object was to get something which would really please the person, or amuse the child to whom it was destined, and all the attention of the buyer was centered on that point. Now, it is wholly different. The giver's sole idea is to be looked upon as a man of taste, or, at least, as a very original being. He must get the striking novelty of the day, or the most dainty piece of old fashioned style, and, as he knows where to find it, having stopped very often in his strolls before those places, he goes at it without hesitation, and sometimes at the very last moment. I must say that intelligent retailers (as now they all need be) thoroughly understand the taste of their customers and generally manage to provide for their fancies.

Christening sets in silver admit of a great variety of decoration. They can be made almost at any price, according to the quantity of pieces. The large ones include: a rattle, round in shape, having no point, with a pearl handle or an ivory ring; a goblet; a spoon and a fork; a silver bladed knife; a little saucepan; a panadière (vessel in the shape of a wooden shoe out of which infants are made to drink); a hollow plate; a shallow one; a serviette ring; an egg cup standing on fowl's claws with a spoon whose handle has the shape of a tiny feather. Sometimes, to the above pieces is added a lilliputian coffee cup which the happy being will be allowed to use as soon as he begins to move about. Those sets are generally decorated in aquafortis or *repoussé* and finished off in dead or oxidized silver, the inside of some pieces being gilt.

I have seen a very elegant brooch made of diamonds. It represents three birds different in size and flying in the same direction. They follow each other at a short distance, and there is in the whole of it such a go that the sparkling wings actually seem to flutter.

Another one shows, on a piece of ground worked in sunny metal, two fowls in enamel and gold who confront each other defiantly. A pearl lying between them and evidently supposed to be a seed is, no doubt, the cause of the contest.

Blonde and dark tortoise shell, mounted or inlaid with gold, platina and silver, or adorned with gems, is not only the fashion for hair combs and *face-à-mains* but also to some extent for cigarette cases, pocket books, purses, *carnets de bal*, and even watch cases.

JASEUR.

Oxidation on Silver.

WE FIND the following process for oxidizing silver in the *Journal des Applications Electriques*:

The salts of silver are colorless when the acids, the elements of which enter into their composition, are not colored, but they generally blacken on exposure to light. It is easy, therefore, to blacken silver and obtain its oxide; it is sufficient to place it in contact with a sulphide, vapor of sulphur, sulpho-hydric acids, such as the sulphides or polysulphides of potash, soda, dissolved in water and called *eau de barège*. The chlorides play the same part, and the chloride of lime in solution or simply *eau de javelle* may be used. It is used hot in order to accelerate its action.

The bath must be prepared new for each operation for two reasons: 1. It is of little value. 2. The sulphides precipitate rapidly and give best effects only at the time of their direct precipitations. The quantity of the re-agent in solution, forming the bath, depends upon the thickness of the deposit of silver. When this is trifling, the oxidation penetrates the entire deposit and the silver exfoliates in smaller scales, leaving the copper bare. It is necessary, therefore, in this case to operate with dilute baths inclosing only about 3 grams

(45 grains) of oxidizant at most per liter. The operation is very simple: Heat the necessary quantity of water, add the sulphide or chloride and agitate to effect the solution of the mixture, and then at once plunge in the silver plated articles, leaving them immersed only for a few seconds, which exposure is sufficient to cover it with a pellicle of deep black blue silver. After withdrawing they are plunged in clean cold water, rinsed and dried, and either left mat or else polished, according to the nature of the articles.

Should the result not be satisfactory, the articles are brightened by immersing in a lukewarm solution of cyanide of potassium. The oxide, the true name of which would be the sulphuret or chloruret, can be raised only on an object either entirely of silver or silver plated.



[FROM OUR SPECIAL CORRESPONDENT.]

THE TONE OF THE ENGLISH MARKET.—NEW STYLES AND REVIVALS OF OLD.—THE LANCASHIRE WATCH SYNDICATE.—WHAT IS A WEDDING RING?

LONDON, May 10, 1889.

In spite of opinions to the contrary, expressed in some of our journals, I am satisfied that the business now doing in the various branches of our trade is fairly good. The manufacturing and factoring (wholesale) houses have every reason to be content with the Easter season. Whether our shopkeepers have been equally fortunate in their sales I have not yet ascertained.

Leaving official returns out of the question for once, and judging solely by my own observation in and about almost every department of the jewelry trade, I am inclined to think that the business for the first four months of this year will be found a decided improvement on that of the same month of several previous years.

Mounted stones are still in good demand, especially diamonds. It is noticed that the enquiries lately have been more for the better class of articles. Brooches are still in request, and the inventions of our designers are seen in several new patterns. Spray brooches of oxidized silver are being brought out in various designs, and seem to be going off well. Coral is said to be finding favor in various quarters. Manufacturers are making up various styles of the pale stone, so I suppose they know there is, or will be, a demand for it. The manufacturers of gold chains are tolerably busy—more so than they have been for some months, and I learn from them that the public are preferring hall-marked goods to others. It appears to me that this must be the natural outcome of the recent scare—people who buy expensive jewelry will ask for and select only such as carries an official estimate of its worth.

Stud and solitaire makers are very busy. A spurt has doubtless been given to this particular branch by the recent expiration of a popular patent for solitaires. The worst of this is that in the heat of competition to secure orders of some kind prices have been reduced too low to leave any profit. Solitaires have not yet been reduced to the lowest level of so-called jewelry, that is, to the hands of the street vendor, but I expect they soon will be. The way to prevent this is not to repeat the production of worn out designs and to rely upon a reduced price for a sale, but to devote ingenuity and capital to the production of something both new and good. The "novelty" will sell the design, while the "quality" will keep it from the lower grades of vendors. There are some new devices in solitaires that are calculated to do good to the trade as well as to their originators.

I have just had shown to me a ring that certainly has novelty for

a recommendation. It is composed of gold and silver coils alternating, and is snake-like in appearance.

In common with other members of the trade, I received an invitation to a private view of the exhibition of goldsmiths' work and jewelry which took place at Vienna on the 20th inst. This unique exhibition was held at the Schwarzenberg Palace, Vienna, and was opened to the public on April 22. I have attended rather a formidable number of exhibitions the last few years, but none have had the peculiar interest that has attached to this remarkable one. The exhibition at Vienna was of unusual interest because of the class of exhibitors, the character of the exhibits, and especially because of the object for which it was held. The principal exhibitors belong to the leading families of the Austrian and Hungarian nobility; the proceeds of the exhibition will be distributed among the poor of Vienna, and it may safely be asserted that for no other purpose than that of charity could such a collection of valuable and historically interesting articles be made.

There are many pretty and new things in fancy jewelry which one can see duplicated, in a sense; the originals appear in all the splendor imparted by diamonds and other gems in the jewelers' shop proper, while imitations of them may be seen in very pretty materials, without any pretensions to be anything better than imitations.

A novelty is the merry-thought of a fool, made of paste, and neatly arranged with floral decorations as a brooch—a strange combination, but not so strange in appearance as it seems in mere description. There are some very pretty flower brooches in the windows—a very timely idea to exhibit them just now when the real flowers are becoming daily more accessible.

The mania for the formation of syndicates increases rather than otherwise. So many Utopian schemes have been projected, bringing disappointment, loss, and, in some cases, ruin to most of those who have embarked in them, that the wonder is that even legitimate enterprises are favorably entertained. There should be a wide distinction between companies or combinations formed for legitimate trading, and what are now commonly called "rings." It is to be regretted that the difference is not always apparent. It would be difficult to enumerate the various "combines" (I think you admit that word, it is not yet current here), that have lately been presented to us. Amongst the more prominent of those connected with trade, we have had "copper rings," tin trusts, salt unions, the great flour ring, a gigantic coal syndicate projected with a capital of *one hundred millions of pounds*. This multiplication of trade syndicates is becoming a serious matter. I do not look upon them with much favor, but on the other hand, I do not agree with those who so fear them that they desire a government enquiry into them. The less a government interferes with the business of a community the better it will be. The plea put forth in favor of these unions, or trusts, or syndicates, or associations, or whatever else they may be called, is that they are formed for the protection of British industry. This, to me, is pure nonsense. The idea that British industry wants government protection I regard as an exploded one. John Stuart Mill—and he was no mean authority on these matters—said that "no permanent rise of prices can benefit anybody except at the expense of somebody else." This would be consulting the greatest good of the *least number*, whereas we all know that the common sense basis of political economy is the greatest good of the greatest number. Now, my objection to syndicates is in those cases where the only object is to force an advance in prices. When a company obtains increased prices simply by combination, the extra profit, as a rule, go to shareholders who have taken no part in earning them. Of course, I do not object to *all* combinations; there are companies *and* companies. Because many syndicates are formed solely to exact for the few a higher price for any commodity than it is really worth to the many, it does not follow that all companies are therefore to be condemned. I look upon the Lancashire Watch Company with more favor than I should do, because the circumstances under which it was originated

are quite a sufficient reason for its existence. This company owes its existence to the passing of the Merchandise Marks Act. This act has certainly diminished, and to a great extent, the importation of foreign watches into this country. Considering that such importation is not prohibited and that it is not hampered by heavy import duties, it may be a mystery to many why the act should have had the effect of checking the importation. The fact is that this interference has proved what was not openly admitted before, that for a long time past watches of foreign manufacture have been sold as English made watches. As a matter of necessity, these imported watches were cheaper than those of English make. Seeing, then, that a certain supply from abroad appeared to have greatly decreased and that it was probable there would be increased demand for English watches. I can quite understand our larger manufacturers uniting their efforts to meet that demand, and to take the full advantage of the opportunity of supplanting the foreign makers. I believe if the company had been somewhat differently constituted, so as to make it the joint effort and the joint benefit of makers and workmen to produce just the watches that are required at the time, they could have produced a *complete, cheap* and good English watch. It was only on these lines that I ever saw any chance of success for the syndicate, because, in my opinion, there was no other sound reason for its existence at all. The field they had to work in was distinctly pointed out in the prospectus which reminded us that while in 1887 the value of watches and parts of watches imported amounted to £750,750, in 1888 the total value only amounted to £585,369. It was stated that the company comprised all the principal watch movement makers in Prescott and several from outside. A very good feature of the prospectus was that only about £4,760 was to be paid in cash to purchase the machinery and tools (and, I believe, the stocks as well) of the firms amalgamating. The balance of the purchase money was to be accepted in shares. The capital is £50,000—in 5,000 shares of £10 each. Of these, 1,610 shares are issued as fully paid, and 3,390 are offered to the public. I have not now much faith in the company ever effecting the purpose I expected of it. I know some of the promoters have left—opposition companies are being floated—particularly the "Coventry Watch Movement Manufacturing Company." It would not be wise, and if your paper was published in London it might not be safe, to say all I think respecting the probable future of these syndicates. But this much I may say, that I think it will yet devolve upon private enterprise to redeem the position of the English watch trade, and I am firmly of opinion that private enterprise will do it.

There is still much controversy on the subject of hall marking and scarcely a week passes but it presents some new phase. To give you one instance—it seems that it is lawful to make, and, of course, to sell, gold rings that have not been hall-marked, provided they are not wedding rings. This has raised the apparently very difficult question, what is a wedding ring? A jeweler has been selling plain gold rings, not hall-marked, and of the value of nine karats only—that is to say, five eighths of their substance is not gold at all. The question was raised, were these wedding rings within the definition of them by the act? This was not a trivial question, as you will understand when I say that this jeweler is said to have rendered himself liable to fines amounting to above £700. This is not an isolated case, as scores of jewelers are in precisely the same position. To an ordinary mind it would appear that any plain gold hoop ring that will fit the third finger of a lady's hand is a wedding ring. The difficulty is that these rings are used as scarf rings. Of course, these are not then wedding rings and they should have been hall-marked. Our lawyers have been contending that a ring cannot be a wedding ring until it has been used as one. This would leave the jeweler free to sell all rings without the hall mark, but he would run the risk of being prosecuted if the purchaser afterwards used his scarf ring as a wedding ring. Either wedding rings must be exempt or every plain ring must be compulsorily marked. The feeling of some portion of our trade was indicated in the House of Commons a few days ago,

when in answer to a question the Chancellor of the Exchequer said, "he had received evidence of the very strong feeling of the silver trade that hall marking should continue compulsory. In reference to the recommendation of the Royal Commission on gold and silver duties, the Chancellor has stated—also in the House, so that the announcement is official—that he could not accede to any proposal for the abolition of the duties on gold plate, but that he should be glad to see his way to abolish the silver plate duties, but the state of the revenue would not justify any steps this year. VIGILANT.



[FROM OUR SPECIAL CORRESPONDENT.]

ATLANTA, May 20, 1889.

The summer is all but upon us, but the usual sensation of sudden transition is not experienced, owing to the fact that the past seasons have been so much like a summer that it is difficult to draw the line just where one ends and the other begins. Notwithstanding the unusual condition of the weather, Atlanta seems to hold her own and is at present pushing on with her accustomed energy. On the 11th of the month the Chamber of Commerce of this city adopted a policy, that when materialized will be bound to prove of incalculable benefit to the city and to the South. At the meeting it was decided to form an association with a capital stock of \$600,000 for the purpose of aiding and advancing small industries, and for the purpose of proving to several manufacturers of the North and West, who are inclined to think favorably of a location in Atlanta, but who fear a change because of a supposed indifference of the people, that the contrary is the case, that the people would welcome such additions with every sign of encouragement. The latter is the principal purpose of this Chamber of Commerce Association. Our people have rapidly taken the stock and the scheme bids fair to place Atlanta in the van of all southern cities.

But about the jewelry trade. It has been exceptionally good for this time of the year. The large storerooms of Freeman & Crankshaw, J. P. Stevens & Bro., A. L. Delkin & Co., F. J. Stilson and A. F. Pickert are well patronized during these warm days. This shows that they are selling goods that the people will buy and that trade is keeping up pretty well. A good many purchases in costly wedding presents are being made for the month of June, and it is likely this trade will keep up for a few weeks yet.

L. Snider since consolidating his two stores seems to be doing a big business.

The success of J. P. Stevens & Bro. in the watch club business is perhaps beyond parallel in the history of the jewelry business in the South. They have watch clubs in a large number of the towns and cities in this State, and are increasing the number of their clubs in other States.

Fred. J. Stilson some time ago secured the services of J. S. Doyle, one of the most practical jewelers in the South. T. J. K.



[FROM OUR SPECIAL CORRESPONDENT.]

ORGANIZING FOR PROTECTION.

MINNEAPOLIS, Minn., May 17, 1889.

A very important movement is on foot among the retail jewelry dealers in St. Paul and Minneapolis to effect an organization, which, it is hoped, will in some particulars benefit the trade. A meeting was held at the Ryan Hotel, in St. Paul, on Monday, May 6, at which there was a pretty full representation of the retail jewelry dealers of St. Paul, together with a few from Minneapolis. The retail trade here has suffered considerably from the competition from jobbers sending catalogues, and more especially from the sale of goods by the installment houses, and in some instances by the dry goods and general stores. Several so-called "watch clubs" have also been organized, and between these various sources of competition the retailers find considerable cause for complaint and their trade is being badly cut up. Even some of the old retail dealers have found it necessary for their own protection to go into the installment plan. At the meeting held in St. Paul, May 6, the matter was very fully talked over and the following resolutions were adopted:

Resolved, That the retail jewelers of St. Paul and Minneapolis, assembled, organize an association for the purpose of promoting and protecting the interests of the retail jewelry trade, in an effort to secure the abolition of the general circulation of jobbers' catalogues, and of the club and installment business in American watches and other evils detrimental to the business of the retail jeweler.

And, That the next meeting of the association for the object of permanent organization to be held at the West Hotel, Minneapolis, Monday, May 20, 1889, at 8 o'clock P. M.

And, That a committee of five be appointed by the chairman to draft a constitution and by-laws, to be submitted at the next meeting, and that notice of the meeting be sent to the retail jewelers throughout the State and their presence and co-operation invited.

Among the firms or persons present, or who have since endorsed the resolutions, were the following parties: M. Albrecht, Wm. Anderson, E. C. Arosin, C. C. Bergh, Bockstruck & Lee, J. D. Bodford, W. H. Breen, Bullard Bros., P. F. Egan, F. M. Finch, Thos. Gaskell, Emil Geist, Geo. R. Holmes, J. E. Ingham, Myers & Co., John Pfeister, G. E. Reed, A. H. Simon, all of St. Paul; Wm. Bard & Co., A. C. Clausen, F. W. Hanson, M. C. Kummerer, B. B. Marshall & Son, G. A. Miller, J. M. Donelson, Tindolph & Co., Weld & Son, Wilk Bros., all of Minneapolis. A circular invitation has been sent out in accordance with these resolutions to all the retailers in the principal cities in the state, and it is hoped to secure a very full representation at the meeting to be held on Monday evening next, when the matter will be gone over and fully discussed. The plan of organization is to effect some sort of a combination among the retailers in this State and then secure the co-operation, if possible, of retailers in other adjoining States. The active participants in the movement are fully aware that they have a fair-sized contract on their hands, and that to accomplish the purpose which they have set out to accomplish means a great deal of hard work and the encountering of numerous obstacles. The responses to the circulars indicate that there will be a pretty full representation at the meeting to be held on Monday evening. The retailers will make a special effort to prevent the sale of watches outside the regular channels. It is becoming the practice in these two cities to canvass for the sale of watches, and the peripatetic retailer with his case of samples, which he is ready to sell, in

BALANCE.—Three things cause a loss of the balance velocity, viz: the resistance of unlocking the escape wheel, the friction of the pivots in the holes, and the stress of the reciprocating spring on the pivots. If the mass of the balance is unbalanced the pivots will suffer an additional stress from the centrifugal force in revolving.

counting rooms, in offices and in the business blocks, is no stranger about the two cities.

Trade is not particularly good with either the wholesalers or with the retailers, a condition not peculiar to the jewelry trade alone, but common to all lines of trade in the Northwest. Real estate is exceedingly dull in St. Paul and Minneapolis for the first time in several years, and this, of course, has its effect upon the class who have enjoyed turning handsome profits from time to time from real estate deals. As a whole, too, the crops in the territory northwest of this center of trade were not particularly good last year, and the country certainly poor. Dealers, therefore, are enjoying only a moderate trade. In Minnesota this is the tax paying time and this also makes money close. However, the outlook is exceedingly good. Recent rains have bettered the situation. The prospects here are better than they were a week or two ago, and a much more cheerful feeling prevails in the country.

The long-contested case of the Van Norman Bros., who assigned here something over five years ago, periodically bobs up in the courts. Recently Judge Young rendered a decision in the matter of a claim to Lapp & Flershem, of Chicago. C. C. Bennett, assignee of the Van Norman Bros., disallowed the claim of the Chicago firm against the estate, and the latter appealed from the disallowance court and holds that Lapp & Flershem are not entitled to prove their claim, and that they have by their unfriendly proceedings necessarily exhausted a sum larger than their share of the estate.

W. L. Pettitt, a wholesale dealer, doing business in Minneapolis, is a candidate for the position of United States census taker for Minneapolis. Mr. Pettitt was exceedingly active in politics last fall, and during the past winter he was largely instrumental in the election of Congressman Snyder from the St. Paul and Minneapolis district, and later gave Hon. W. D. Washburn more or less assistance in his canvass for the United States Senate. Mr. Pettitt's candidacy is meeting with more or less opposition from men who want somebody of more experience to take the census.

The Minnesota Watch Co. has been incorporated with a capital stock of \$10,000. The place of business is St. Paul, and the incorporators are J. D. Caldwell, C. H. Walton and W. H. Richardson. The company is incorporated to do a retail business, and not, as its name indicates, to make watches.

W. Strohmier is a new manufacturing jeweler who has recently located in this city.

F. M. Finch, who three or four years ago located down in the jobbing district below the Merchant's Hotel, in St. Paul, has found his quarters too small, and has recently moved three doors north of Jackson street, above the Merchant's Hotel, where he has fitted up a very handsome store.

Pendulums.



PENDULUM required to vibrate seconds, says a lecturer, must be of such a length as to make the distance between the centers of suspension and oscillation 39.14 inches; and it must farther satisfy the condition here indicated, namely, the expansion of steel downwards must equal that of brass upwards. The co-efficients of expansion of steel and brass are respectively 0.0000124 and 0.0000188 per 1° centigrade, and it can easily be shown that the smallest number of rods that can satisfy this condition, keeping the pendulum symmetrical, is nine. The arrangement of the rods and the mode in which they effect the required object need but little explanation. The outer steel rods are firmly pinned at right angles to the upper brass cross-piece, but they are only held loosely by the pins in the lowest cross-bar. This carries two brass rods expanding upward, and each pair is loosely held by pins in the same way. The innermost steel rod hangs from a pin at its upper end, passes freely

through the lower cross-piece, and supports the pendulum bob by a nut at its extremity.

The necessity for so many rods has always been regarded as a serious objection to this form of pendulum, and many attempts have been made to avoid the difficulty. Troughton suggested a very elegant arrangement, in which the four brass rods are replaced by two brass tubes, the five steel rods being joined in a manner corresponding to that above indicated. The bulk of the pendulum rod is thus diminished to a tube .6 of one inch in diameter, an important point, since the center of oscillation is thereby lowered, and a shorter pendulum can be employed. Zinc has a much higher expansibility than brass, and attention was, therefore, directed toward the employment of this metal. By increasing the length of the pendulum, and placing the bob some distance above the lower end of the pendulum, supported by a short cylinder of zinc, Berthoud succeeded in obtaining sufficient compensation with only two brass rods and three of steel; and, even with a brass cylinder in place of the zinc, the compensation was at times found to be complete. This is a compact form of gridiron pendulum, but long, and the excessive friction between the rods is a serious objection. Berthoud constructed them about 13 inches long, beating half-seconds, and the center of oscillation comes very near the center of the bob.

Reid, Tiede, Jacob, Ward, Dent and others, inverted pendulums in which zinc and steel are employed in conjunction, and in an interesting arrangement suggested long ago by Robert, zinc is associated with platinum as being at the opposite end of the scale of expansibility. The form adopted by Jacob is worthy of notice on account of its extreme facility of adjustment. The central rod is of steel, and terminates in a screw bearing a locking nut, which supports a rectangular zinc frame. A screw thread is cut on the upper portion of this, and a nut on it supports the frame that carries the bob. Assuming the pendulum to be under or over compensated, it will only be necessary to elevate the upper screw and depress the lower, or *vice versa*, and the effective length of the zinc will thus be altered as required. The expansion of zinc being more than double that of steel, a single zinc rod less than the length of the pendulum will suffice for the compensation.

The only other combination of these two metals that need be specially referred to is the pendulum employed by Dent & Co., of London, England, for astronomical clocks, in which the bob is of lead, and the steel and zinc are two concentric tubes, the rod also being of steel. A zinc tube resting on the rating nut supports, at its upper end, a steel tube by which it is enclosed; to the lower end of the steel is fixed, by its center, the lead bob covered with a brass jacket. Holes are drilled through the steel and zinc tubes in such a manner that each portion of the pendulum is equally influenced by thermometric variation.

The pendulum by Mr. Robert, above referred to, is a light platinum tube passing through a zinc bob and terminating in a steel screw, which carries the rating nut. The bob extends to half the height of the rod, and its upward expansion is sufficient to neutralize the downward expansion of this latter.

Numerous other combinations of two or more substances have been suggested from time to time, but detailed reference to them is unnecessary since the principle of all is identical. J. L. Smith employed a vulcanite tube surrounding the lower extremity of a steel rod, in a manner somewhat analogous to Berthoud's pendulum, only that the tube passed within the (copper) bob; Ley used zinc and glass similarly arranged, and Callaud proposed a combination in which steel, brass, and platinum (wire) are used. The brass tube resting on the timing nut supports a plate at its upper end, through which pass two screws attached to the extremities of a platinum wire. This passing round a groove in the pendulum bob raises it as the brass tube expands, and the adjustment for compensation somewhat resembles that of Jacob's pendulum. Benzenberg's pendulum, as modified by Kater, consists of a lead tube traversed by an iron wire, the bob being suspended by two iron wires from the upper end of

this tube. By employing steel and zinc, Kater succeeded in reducing the length of compensation metal so as to conceal it within the bob; and Bailey proposed a cheap construction that has been much used, in which the upward expansion of a cylindrical lead bob neutralized the downward expansion of a deal rod.

It is unquestionable that a carefully made wooden pendulum is to be preferred in all clocks, other than the very best astronomical timepieces; in conjunction with a well made train, it can be relied upon to give a more uniform rate than any unadjusted compensation pendulum. Indeed, such a pendulum may give rise to a very great irregularity, if, as is perfectly possible, the arrangements for compensation tend to produce an opposite effect to that which is required.

An immense variety of devices have been proposed for correcting this error of temperature, but they may all be classified under four heads:

1. Two or more solid and rigid substances employed in conjunction, and so arranged that the vertical downward expansion of one is neutralized by the vertical upward expansion of another.
2. Two metals of different expansibilities actuating levers, and thus maintaining the length of the pendulum invariably.
3. Two metals of different expansibility, rigidly joined together by soldering or otherwise, employed to vary the distance of a weight from the center of suspension whenever the temperature varies.
4. Pendulums in which mercury is employed.

The earliest attempt to correct the variations of temperature was made by Harrison, in his construction of his "gridiron" pendulum, consisting of nine vertical rods—five of steel and four of brass.

Free Hand and Mechanical Drawing.

BY EXPERT.



IT FREQUENTLY happens that we have to lay a sketch to one side for months before we can resume work on it, and when we do the colors are hard dry and have lost much of their freshness. In such cases it is difficult to apply fresh colors so that they will not look crude and glaring. Books on painting give many recipes for freshening up the dry sketch to something near the appearance it had at the time it was laid aside. A favorite method with painters some years ago was to prepare on the palette a mixture

of poppy, oil and saliva, stirring it with the palette knife until it was in a frothy condition. This mixture is applied with a hard bristle brush to the surface of the sketch. Such a composition will undeniably freshen the surface of a piece of work, but the freshness will last but a few hours.

In all matters of art, and, indeed, in matters of all kind, the best course to pursue is that founded on our judgment, prompted by experience. And in the present instance the requirements are to restore the surface of the picture as near as possible to the condition it had when freshly painted; or, in other words, to replace some of the oil which has dried out. Nine-tenths of our prepared colors in tubes are manufactured in the best linseed oil; consequently, if we replace the oil which has dried out of the color we will come very near to the accomplishment of our purpose. Linseed, nut or poppy oil can be used according to the selection of the artist. The method is to use freshly prepared oil so that it is as thin as possible; old oil is thick and viscid, consequently not as desirable for our purpose. The oil is applied abundantly, and after a few minutes a soft woollen rag is used to remove all the oil that can be wiped away. Usually before the re-touching is commenced it is better to let the sketch or

picture stand for a few hours for the oil to incorporate itself with the colors and also to harden a little, but sometimes very desirable effects can be obtained by commencing to work while the "greasy" condition remains. The writer has known artists who took advantage of this condition to rub on dry color to lighten some sky effects. As for himself, he never tried the idea, because he is a firm believer in trying to accomplish the best possible results at the time when the work is done.

I shall beg the reader's indulgence in dealing a little longer in technical details. We often hear artists lament the impossibility of obtaining good colors. This is simply nonsense; there never has been a time in the history of art when as good colors are so well and skilfully prepared as at the present day. It is true we have many colors which have no place in art, but the skilful artist never buys nor uses them. I gave, some months ago, a list of simple colors for dead coloring, believing the student would do better to school himself to a few colors of rather a low key than to attempt the use and management of a full color box. That even in studies it is always the best course to pursue to restrict oneself to weak expressions in color, if I may be allowed the phrase, is questionable. Now, the full strength of the best selected color box in existence is only feeble to express our impressions when studying nature. The reason of my recommending at first the few colors of feeble power was to train the eye to depicting form and relative importance of objects, and then as the eye gained strength and judgment to avail ourselves of all the power of the palette. If the length and scope of these articles permitted, the writer would, with pleasure, dwell on the details of gradually extending the resources of the color box, but being in a sense restricted, he will leave out the intermediate demands which attend a full progressive course, and give a full and complete list of all colors which can be termed absolutely necessary for pictorial purposes. One important feature attends the selection—they are entirely reliable for permanence, and can be used with a feeling of security that time will not speedily affect them. The list given below is copied from Philip Gilbert Hamerton's treatise on the Graphic Arts, and embraces more colors than most artists use and all that seem absolutely necessary:

White, ivory black, yellow ochre, strontian yellow, pale lemon yellow (not chrome), orange cardium, raw sienna, burnt sienna, light red, Venetian red, vermilion, rose madder, madder brown, deep madder, cobalt blue, artificial ultramarine, ultramarine ashes, cobalt green, light emerald oxide of chromium, dark emerald oxide of chromium, terre verte, raw umber, burnt umber, cappagh brown—24 colors in all. Many permanent and desirable colors are omitted for the reason that with the list given about all the strength of the palette can be realized without them. It is quite unnecessary to go into all the details why certain colors are selected and others rejected; experience seems to throw the scale in favor of the list given.

A word in regard to white. The accepted white for oil of this day is some of the carbonates of lead—Kremnitz white, silver white or flake white are all about the same, except in the care and purity of the preparation. Those prepared from zinc lack body. Colors, as they come prepared in tubes, are about the proper consistency for use, seldom needing any addition except some "drier" for rose madder or some other tardy color. Occasionally one needs a little particularly thick color; for such cases a little expressed from the tube on to yellow straw paper which absorbs the oil will answer. Such color is usually applied with a palette knife, spreading it flat and smooth, and afterward giving it form and surface with a brush. I mentioned this in the April number and would beg to add that the use of the palette knife is generally applied to skies and rocks in the foreground.

I have endeavored to give broad and general instruction for technical use of the tools and material employed by the artist in the production of his art. With the next contribution to this series of articles I shall commence a succession of studies from nature and give the details of their technical treatment, which will embrace color and mode of expression and treatment as fully as is possible in black and white. It is only by such inductive methods we can hope to convey anything like a thorough disciplining of the eye and hand.

Fashions in Jewelry

A Lady's Rambles Among the Jewelers.

THE "leafy month of June," from time out of date, has been a favorite season for marriages the world over. It is not only prolific of roses with which to deck chancel and bride, but is rich in folklore that brings all sorts of good luck to the happy pairs who are in wedlock united during its thirty days' reign.

* * * * *

THE dictates of high society in New York City do not conflict with the time-honored custom of "June weddings." On the contrary, June weddings are pronounced quite the "correct thing" by the powers that be, and wedding bells, and wedding rings, and wedding presents are, therefore, now in order.

* * * * *

THERE has come in with the revival of interest in all things pertaining to the last century, awakened by the Centennial festivities, a sudden passion for the old-fashioned trinkets. Naturally this revival extends to engagement and wedding rings, in instance of which may be cited the "Poesy" engagement and the "Gimmel" or double wedding rings.

* * * * *

THE new-old wedding ring, which, by the by, figured at some of the May marriages, is double, so as to open in two, and yet not separate—an emblem of the married state. Within this ring a suitable motto is engraved, and on the inside of the hoop are the initials and date. The "Gimmel," when closed, presents the appearance of an ordinary hoop of gold.

* * * * *

THE first "Gimmel" ring, it is claimed, was worn by Martin Luther's bride, and was designed by Luther's friend, one Lucas Cranach.

* * * * *

AT THE great majority of weddings the ring of pure gold, neither too heavy nor yet too slender, and softly rounded over, remains the ideal marriage token, fitly symbolic of a true devotion "endless, without flaw and pure as gold forever."

* * * * *

THE fashion of engagement rings varies from time to time, and depends, in some degree, upon the purse of the donor.

* * * * *

WHERE there are no limitations to his purse, the modern young man, as did the swain of ancient times, chooses a diamond solitaire for the engagement ring.

* * * * *

THE diamond—or, as the mediæval Italians called it, "*Pietra delia reconciliazione*," because they believed it maintained peace and happiness between man and wife—is generally recognized as an appropriate

gem for the betrothal ring. For generations it has been recognized in gem lore as the emblem of power and devotion.

* * * * *

THE ruby—emblem of exalted love—is sometimes selected, and, occasionally, an emerald—which signifies a promise of happiness—as fitting stones for the espousal ring.

* * * * *

SOMETIMES a ring set with three gems is selected, and occasionally a fine pearl figures in the engagement ring. This latter gem, however, is less often chosen than others for the purpose mentioned, owing to the fact that its beauty is more precarious.

* * * * *

ALTHOUGH pearls are less often selected for engagement rings than more enduring gems, these are in high favor just now and are represented in every bridal *corbeille* of importance. They are set in brooches, bracelets, ear rings and necklaces.

* * * * *

SIZE, as well as luster and shape, is an important item with pearls.

* * * * *

PEARL necklaces are not only in favor with the English aristocracy, but with New York's "Four Hundred." A favored form is that of one or more rows of fine pearls. Occasionally as many as seven or nine rows or festoons occur in one necklace.

* * * * *

A UNIQUE necklace, which owes its novel features to some cunning artificer of one or more generations ago, is worthy of description. It consists of fine pearls, strung alternately with flattened beads of red and of green enamel, from which swings a gold pendant enameled to match and set with colored gems.

* * * * *

PEARL ear rings are in demand, and there is frequently a small but clear white diamond on the ring to which they are suspended.

* * * * *

ON THE occasion of a recent New York wedding, included with other valuable presents were a necklace of large pearls, a diadem made of a row of diamond stars, a *rivière* necklace from which fell diamond drops, several handsome bracelets, and pins, brooches, arrows, flies and butterflies in precious stones, plate enough to furnish beautifully a house on Madison avenue, silver dishes, coffee and tea pots, spoons of all sorts, parasols, umbrellas and fans with gold and silver mounts, and a sufficient quantity of choice ceramics and choice bric-à-brac to furnish several bazaars. Who shall say that weddings are not profitable occasions to our jewelers and silversmiths.

* * * * *

THE *rivière*, it may be explained, is at the present time oftener used as a decoration for the bodice than worn in a conventional fashion around the neck. The rows of gems may be attached to the shoulders and carried across the bust upon folds of the silk or lace of the bodice.

* * * * *

THE demand for slides and buttons with which to ornament Directoire and Louis XV. toilets, has been met, by several ladies of

fashion, by having their family diamonds mounted in form of the required articles.

* * * * * *

AS THE "chic Anglaise" is just now the rage among our society women, the records of court dress are welcome. In this connection, therefore, it may be well to explain that the favorite jewels at the drawing rooms are diamonds, but women who possess other precious gems wear them *ad libitum*.

* * * * * *

ENGLISH women cover the front of their bodices often with diamond brooches of quaint and curious form, and the fashion is more or less imitated here.

* * * * * *

VERY large diamond stars are worn, and a new style of stars have waved rays or rays with small gems between.

* * * * * *

THE less setting there is about a choice gem the better pleased appears milady, and one sees diamonds joined by almost invisible links, not only for rivières and necklets, but for various sorts of pendants.

* * * * * *

Rows of pearls and rivières of diamonds and phenomenal solitaires are beyond the reach of most women, but this large class of patronage wear jewelry, and jewelry, too, that enhances the completeness of dainty and artistic toilets. It is with this widespread patronage that our jewelers find a ready and profitable market for such ornaments as represent the best work in the goldsmith's art—work that has a value outside of its intrinsic worth.

* * * * * *

MANY of the ornaments of to-day aim at quaintness rather than absolute beauty; others are fac-similes of objects in nature, while others are plain geometric forms depending for their attractiveness in the harmonious blending and association of colored gems and enamels.

* * * * * *

THE multiplicity of designs in jewelry has the advantage of allowing every one's ornaments to be individual and expressive of the wearer's self. For instance, a musician may have a brooch or scarf pin simulating the bars and treble clefs in gold and tiny diamonds; a diamond fox, gem-set, in shape of a domino, enameled bulls and bears, and gold crops crossed with a gem-set horseshoe, are a few other suggestive models reproduced by our jewelers.

* * * * * *

THE trail of the mariner is observable in much of the newer jewelry, and also in silver table ware, sea shells and wave lines, boats, fishing rods, coral and weeds and other tokens of the sea, occur in the decorations.

* * * * * *

FLOWER brooches are among the most attractive and fashionable of the simpler jewelry, and in these has appeared a demand for many of the old garden flowers. The heartsease, in tinted enamel, is a

prime favorite, and the same is true of the dog rose, which latter is not only reproduced in pale pink, but also in blue and mauve and creamy white.

* * * * * *

EXCEEDINGLY pleasing effects have been gained in brooches, lockets and pendants, with pierced gold work laid over a colored enamel background.

* * * * * *

FILIGREE gold work, with and without gems, is again popular in jewelry.

* * * * * *

FINE moonstone brooches remain in favor, especially when carved and set about with diamonds. A style most in favor consists of the face of the typical man in the moon circled within a diamond crescent.

* * * * * *

A LACE SCARF pin produced in both gold and silver and attracting considerable attention, has for its design six blind mice. These rodents are made to assume a variety of postures on a long bar.

* * * * * *

THE outline heart of diamonds, pearls, sapphires or ruby garnets makes a charming brooch or scarf pin.

* * * * * *

DOUBLE circles linked together, with stones set at intervals, make pleasing brooches.

* * * * * *

CUFF links are out in new designs, in illustration of which is noted the padlock and key links, the crop and horseshoe links, the canoe and paddle links, and gold and platinum horn and crop links.

* * * * * *

A QUITE new bracelet consists of a gold wire circlet, around which is twined the stem and leaves of the heartsease, two blooms of which appear on top of the bracelet in enamel that reproduces the natural tints of the flowers.

* * * * * *

ONE of the most attractive "1889" brooches seen had the figures surrounded by a ring of pearls, and this, in turn, was encircled by a heavily chased gold border.

* * * * * *

CUFF links, which for several seasons have been almost entirely confined to use by men, are, it is claimed, coming into fashion again for ladies' wear.

* * * * * *

THE sun-star is, just at present, a favorite method of setting diamonds. In this design the points of the many-rayed star are circled by another row of diamonds, from which starts forth a fresh succession of rays. This sun-star is very effective as an ornament, whether worn at the neck, in the hair or clasping the drapery of the bodice.

JEWELLED ornaments for the hair have not fallen off in importance; on the contrary, their employment is, if possible, more widespread than ever.



THE forms assumed by pins and combs are legion, and frequently—as when there are three prongs and a decorative top—it is not easy to decide whether the article ought to be classed as the former or the latter.



TWO-PRONGED pins, with a gold top decorated with chasing or with stones, are in considerable favor, and similar pins ornamented with biscuit-colored enamel are among novelties.



HANDSOME bracelets of elaborate pattern and florid style are often worn in the hair instead of on the arm.



NUMBERED with attractive bracelets are those in which occur a plain row of stones, or two or more rows set side by side—diamonds with rubies or sapphires or else the three, forming a tricolor band.



WIRE bracelets, on the clasp of which appears cat's-eye, topaz or other stone inclosed in a ring of small diamonds are in demand.



BANGLES remain popular. A novelty in this line is known as the "Shakespeare," because on each bangle is engraved a brief quotation from the immortal poet.



A BRACELET much favored as a souvenir to bridesmaids, is a stiff gold band finished on top with a moonstone heart encircled by pearls.



A BROOCH which comes under the head of "luck and love" jewelry, consists of a gold horseshoe with diamond center and two hearts outlined with pearls interlaced on either side.



GOLD balls set with brilliants, balls enameled and balls of filigree gold work are very fashionable, and are employed as ear rings and pendants to bracelets and watch chains.



SOME attractive lockets and other watch charms seen, depended for their decoration on an applied design in gold on a colored enamel background.



THE button hook jewelry, which was described on its first introduction, and is of English origin, has gained favor here. As the name betokens, it is utilitarian as well as ornamental in character, and is made either as a brooch or bracelet.

THE button hook brooch consists of a double knot with a gold ball in the middle and at each end. Concealed behind the brooch is a button hook which can be easily opened out, and is quite strong enough for all ordinary purposes.



IN THE button hook bracelet the button hook serves a double object, for, by being fastened around one of the gold balls, it affords an admirable clasp.



A NOVELTY in cases, introduced in Paris for the Easter trade and which has found its way into some of the New York stores, consists of white morocco egg-shaped boxes. These unique affairs are lined with white satin and contain a yellow velvet puff, in imitation of the yolk of an egg.



EGG-SHAPED morocco cases are employed by one of our silversmiths for holding silver egg cups which simulate broken egg shells. These silver cups have proven a favorite present where small pieces of silver are in request.



A NOVELTY in silver egg cups represents a broken egg shell mounted on a tripod, formed of three fowls' feet.



AN ODD silver piece consists of a small tray, on one end of which is half of a silver egg shell for an egg cup, and on the other end the other half of the shell for a salt cellar. The chink in the center of the tray serves as a pepper shaker.



THERE is a wide diversity in way of small silver trays. Some are irregular in shape, bordered in the Louis XV. style with acanthus leaves, some are square with Empire bordering, while others are finished with a line around the edge.



THERE was quite a number of new styles out in the knit or woven gold work, now familiar to all of our jewelers. The woven work bracelets and chains are especially popular.



AMONG novelties introduced for the convenience of the sterner sex, are clamp scarf fasteners, made not only in sterling silver, but in gold, and showing chased and jeweled designs.



ARABESQUE and floral designs, traced with inlaid gold in different colors, are to be seen on some of the new watch cases.



SOLID silver table ware includes richly chased tea sets, in bright and oxidized finishes.



A NEW spoon pattern, seen recently, bears the name "Siren," which is suggestive of the decorative design that appears on the handle.

SCENT cabinets and liquor frames of polished wood, with silver bars and mounts, have self-acting locks and contain beautiful cut glass bottles.

* * *

* * *

* * *

NUMBERED with novelties in clocks are some in quaint early English brass and silver frames.

* * *

* * *

* * *

A DECIDEDLY useful novelty in silver is the combination letter weight and stamp box. This will find its way to a great many counting rooms and desks before the season is over. It ought to prove a boon to women, who almost never know the rates of postage for printed and written matter, as these are engraved on the stamp box.

ELSIE BEE.

A Master Work.

A RICH artistic token in the form of an archiepiscopal cross which has recently been finished in this city will be sent to Minnesota, where a metropolitan see has been created, with the Rev. John J. Ireland appointed to preside as the first Archbishop of St. Paul. This production is in gilt, with filigree ornaments and jewels combined in an elaborate style. The cross itself is forty-four inches in height, and the staff fifty-nine inches. The sides of the square base are set at the center with single large sapphires and amethysts, one in each panel in regular alternation of the varieties, with raised work in filigree covering the adjacent surface. A globular section above in the formation of the upright bar is adorned with medallions representing in bas-relief the four Evangelists. The ends of the two arms of this archiepiscopal cross show heads of the Evangelists sculptured in silver, with encircling ornamentations in filigree work and precious stones. The figure of Christ is at the center in full relief of about ten inches in height, and is of gold, with a great ruby of fine deep color just beneath the feet. At either side, near the hands, are set two large amethysts on the lower arm of the cross. Above and behind the bent head is a medallion with the Agnus Dei, surrounded with intricate ornamentation, including gems in opals and turquoises. The angles are filled with pierced work in elaborate and delicate character. A small medallion at the top of the vertical bar represents St. Peter, and below the central figure is another in representation of St. Paul. The varied divisions of the work are richly marked with sapphires, emeralds and other precious stones. The reverse is designed with angels' heads appearing singly on the arms of the cross, and in two in the medallions on the upper and lower parts of the piece. This side, like the other, is highly enriched with precious stones, as well as with fine ornaments in filigree and chased designs.

AN EMPEROR'S PASSION FOR JEWELS.—Leo IV, Emperor of the East, was passionately fond of jewelry. The Byzantine historians assert that being present in the church of St. Sophia on Sept. 8, 780, he was struck by the splendor of the precious stones in a crown which Emperor Maurice had suspended above the altar. Immediately removing it, he put it on his head and carried it into his palace. The superstition of the age affirmed that this act of sacrilege was punished by an eruption of the skin, which, in a few days, terminated his life at the age of 30. The historian Platina ascribes the death of Pope Paul II to a similar cause. He was so fond of jewels that he spent immense sums of money in collecting them from all quarters, and in these purchases exhausted the treasury of the church. Whenever he appeared in public his head did not seem to be that of a prelate, but rather "of a Phrygian Cybele, loaded towers." To the weight of this gem incrustated structure (and his extreme corpulence) may be attributed the fit of apoplexy which carried him off.

Copyrighted 1888 by Charles A. Bucklin.

Mechanical Ocular Defects.

Their Nature, Cause, Correction and Relations to Functional Nervous Diseases.

EDITED BY C. A. BUCKLIN, A. M., M. D., NEW YORK.

[The aim of the author is to produce a clear and thoroughly practical course of instruction on the subject of "mechanical ocular defects," which is entirely void of useless technicalities and within the easy comprehension of every thinking student, without his having had any previous technical or mathematical education.]

LENSES.



HAVING DESCRIBED lenses, we will now consider the special action of various lenses on light, their measurement, quality, analysis and framing. We have already seen that convex lenses focus all rays of light passing through them at a common center.

Theoretically, the *double convex* lens has two equally convex surfaces; practically, their convexities are more frequently unequal. Thus, if a grinder wishes to produce lens No. 6½, he grinds on one side with a shell made to grind convex six, and on the other side of the lens he grinds the surface with a shell used to grind convex seven.

The *periscopic convex lens* has a convex surface on one side and a concave surface on the other, in proportion as the sharpness of the convexity exceeds the concavity; the lens acts as a convex lens.

The plane convex lens has its entire convexity on one side, the other side being plane.

Some persons can see through a given double convex lens, but they are unable to use with comfort the same number of periscopic convex lenses, while other individuals can use the periscopic but cannot use the double convex lenses. The majority of individuals can see equally well through either lens.

By glancing obliquely through any convex lens at an astigmatic disc, it will be observed that a most decided cylindrical effect has been produced; this effect is much more decided in double convex than in periscopic lenses. The individual who has a slight astigmatism, which by utilizing the cylindrical effect produced by looking through double convex lenses obliquely can correct the astigmatism, prefers double convex lenses. The individual who has a slight astigmatism, which is increased by the cylindrical effect produced by looking obliquely through any convex lenses, has trouble with all convex lenses, especially double convex lenses. These individuals will complain that if they wish to see distinctly through their glasses they must hold the reading matter up and thus tire their arms. The moment they allow the book or paper to be lowered to a position comfortable for their arms the glasses annoy them. Very small degrees of astigmatism which never attracted the attention of the individual during early life produce this form of annoyance when the individual becomes presbyopic. A weak concave cylinder may be required with axis placed horizontally or a weak convex cylinder may be required with axis vertical to correct a degree of astigmatism which, added to the effect produced by looking obliquely through any form of convex lens, becomes troublesome.

Measurement of lenses. Convex lenses have been and are still measured by the inch system. The inch of the country in which the lens is manufactured is used to measure the distance at which any given convex lens will bring to a focus parallel rays of light. This distance expressed in inches represents the number of the lens. The number of a concave lens is determined by the power of the convex lens required to neutralize it, or by an instrument called a "*foco meter*," which measures the diminishing effect which the introduction of any concave lens produces on the convex system already existing in the instrument.

The want of uniformity in the inch measure among various nations was undoubtedly the cause of the introduction of the *metric system*

for measuring the value of lenses. The following comparison of different values will illustrate the difficulty:

The meter contains	39.37	English inches.
" " " "	37	Paris " "
" " " "	38.23	Prussian " "
" " " "	38	Austrian " "
One English inch contains	25.4	mm.
" Paris " "	27.07	" "
" Prussian " "	26.16	" "
" Austrian " "	26.28	" "

All inches are divided into 12 lines; therefore,

One English line =	2.1116	mm.
" Paris " =	2.256	" "
" Prussian " =	2.18	" "
" Austrian " =	2.19	" "

The difference between the English and French inch is $\frac{1}{12}$.

The inch system has been objected to on account of the irregularity of the focal interval between the lenses of weak power compared with those of high power. *Second*—The lack of uniformity of the inch in various nations. *Third*—The inch numbers represent focal distances and as such are not quickly added or subtracted from each other. In adding or subtracting the values of lenses, their refractive indices must be added or subtracted. The refractive index of a lens is the inverse of its focal distance; thus No. 20 convex has a refractive index of $\frac{1}{20}$. Now, to add two lenses, No. 20, together we would be obliged to add $\frac{1}{20} + \frac{1}{20} = \frac{2}{20}$, or the fraction $\frac{1}{10}$ can be reduced to a decimal; the decimal fractions may then be added as whole numbers. In the table given below, opposite the decimal found by this addition will be found the number of the lens sought.

In the dioptric system no attempt is made to give the focal values of the lenses. A lens of one meter focal value is called *one* dioptric. *One* is the refractive power of the lens. Two such lenses would make two dioptrics. It was proposed to introduce a uniform interval between all the lenses when the metric system was introduced. In this particular they completely failed to in any way improve the irregular interval which exists in the inch system. When we push a convex lens one inch away from the eye we increase its number one; thus if I push convex No. 2 one inch from my eye the lens becomes convex No. 1. Now, the great increase of power produced by adjusting strong lenses enables the individual to compensate for an immense focal interval. With weak lenses nothing practical can be gained by this method of adjusting the distances of the lens; thus if we push convex 40 one inch away it becomes No. 39. Now, the difference between lens No. 39 and 40 would be $\frac{1}{15840}$, or lens No. 1560. No advantage being gained by adjusting the distance of these weak lenses, we are obliged to have a large number of lenses with a much smaller focal interval than we had among the strong lenses. The irregular focal interval found in the old trial sets, which was determined by meeting the practical requirements, has in no way been improved by the metric system.

The following table gives the various lenses found in the trial cases and their focal values, *decimal* refractive indices and dioptric numbers:

Focus in inches	Refractive power in decimals.	Number in dioptrics.	Focus in inches.	Refractive power in decimals.	Number in dioptrics.
160		025	9	.111	4.5
80	.013	05	8	.125	5
60	.017	(.0.67)	7	.143	5.5
50	.020	0.75	6½	.154	6
40	.025	1.00	6	.167	6.5
36	.028	(1.11)	5½	.182	7.5
30	.033	1.25	5	.200	8
24	.042	1.5	4½	.222	9
(22)	.045	1.75	4	.250	10
20	.050	2.	3¾	.267	10.5
18	.056	2.25	3½	.286	11
16	.063	2.5	3¼	.308	12
14	.071	2.75	3	.333	13
13	.077	3	2¾	.364	14
12	.083	3.25	2½	.400	16
11	.091	3.5	2¼	.444	18
10	.100	4.	2	.500	20

We are in fact using the same lenses which always have been used and it is a mistake to suppose that the appearance of any special system of measurement makes any difference in the practical selection of glasses.

Quality of Lenses.—Lenses are manufactured from all qualities of glass and from quartz, crystal or pebble; The power of lenses ground in the same cutter vary considerably owing to the density or refractive index of the substance used. One made of very hard glass will focus stronger than one made of soft glass. A lens ground from a pebble will focus higher than any lens with the same surface which is ground from glass. This is one of the reasons why old people frequently see considerably better with "pebbles" than with the same number of glass lenses. Pebbles are hard and will not scratch, consequently they do not in convex lenses become opaque from innumerable scratches. They become more thoroughly charged with electricity by friction than glass lenses, consequently in certain factories where lint and dust fills the air they become instantly so coated with these particles as to become useless. Pebbles have however an advantage to artisans which can not be thoroughly appreciated by those who have not had experience. The centers of the lenses do not become opaque from scratching where the lenses are carried exposed on a hook.

The best method of detecting a pebble is the pocket polariscope designed by the author. It consists of a short metal cylinder with two pieces of turmalin with the cleavage of the mineral set at right angles; this completely excludes the passage of light, because light can only pass through tourmalin in the line of its cleavage, consequently the light which comes through the first piece of turmalin is completely obstructed by the other piece.

A slot in the cylinder allows any lens to be placed between these two pieces of turmalin. Glass allows light to pass directly through, consequently when a glass lens is placed in the slot, no light can be seen through the instrument. Quartz has a circular polarization. When a quartz or pebble lens is placed in the slot, the light which comes through the first piece of turmalin is twisted by the pebble so that it falls in the line of cleavage of the second piece of turmalin, thus light is seen through the instrument and can only be seen when a pebble lens is in the slot.

SMUGGLING UNDER DIFFICULTIES—One of the strangest cases of diamond smuggling was that of a man who had subjected himself to a great deal of bodily pain to effect his purpose. It was generally understood among his fellow passengers on the steamer that he was a great invalid and was suffering from some incurable blood disease that would eventually end his life. When he came off the steamer, supported by attendants, he was indeed a frightful looking object, his face being a mass of eruptions. What it was that excited suspicions it is hard to say, but something told the inspector that the man was an impostor, and he decided to have him searched. His attendants protested that a search would endanger the life of the invalid, but the look of satisfaction on the invalid's face, however, when the inspector hesitated, settled the matter, and he was brought into the inspecting room and a physician sent for, to take no risks. When the doctor came he felt the man's pulse and looked puzzled. "There is nothing the matter with that man," he said finally, "except extraneous skin poisoning." They had him stripped pretty quickly. His skin was as white and as soft as a baby's with the exception of five red lumps on the inner side of the thighs that looked like large undeveloped boils or carbuncles. The physician examined them curiously and then directed the attendants to hold him. Three or four held him while the doctor made an incision over one of the lumps and extracted—a diamond! The fellow had evidently read that the diggers in the African mines sometimes used this way for concealing valuable gems, and he had tried it. He was the most crestfallen invalid ever seen, for, beside having had all his suffering for nothing, he was out about \$12,000.

Advice to Watchmakers' Apprentices

BY A MAN WHO HAS SPENT TWENTY YEARS AT THE BENCH.



THE BRIGHT concave grooves in the steel wheels spoken of in a former article are first turned with a round pointed tool made not purposely for this job, but for all similar jobs. Turning true and smooth concaves is something a little difficult to do for the average workman, and yet with the special tool I will now describe it is very easy. In using it there is just one particular care to be taken, and this is in having the tool smooth and sharp at the final cut. This avoids deep scratches, so hard to polish out. The tool referred to is made of a piece $\frac{1}{8}$ square, Stubs' steel 3 inches long, with one end tapered to go into a handle as shown at *a*, fig. 1. At the opposite end a hole is at an angle of about 30 degrees. It is well to

make two such holders, one with the hole at *b*, about $\frac{3}{8}$ of an inch in diameter, and the other with a hole about $\frac{1}{8}$. The hole at *b* is broached out slightly taper, and the end of *A* filed to the shape shown in fig. 1, and at the end as close to the hole as is safe and not break out. After the pin *A* is fitted, it is hardened and tempered to a dark straw color. The cutter *c* is fitted into *A* by careful turning, after which it is hardened and polished and the end ground and whet to a bevel as shown at *c*, diagram *A**, and by having two holders (*A*) as mentioned above, almost any size of groove can be turned. In turning a groove in a stem wind wheel a proper tool *c* is selected, a groove turned with it, and if not perfectly smooth, re-sharpen *c*, oil it a little, and with a light chip smooth out the groove just turned.

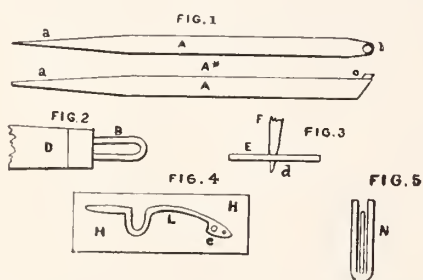

A piece of copper wire of the size *c*, or a little smaller, bent into a loop as shown at *B*, fig. 2, and stuck into a handle *D* used with a little oilstone dust and oil will, in a few seconds, smooth out the groove perfectly. All the fitting of such wheels should be done before hardening. The hardening is done by coating a wheel with a paste composed of boracic acid, yellow ochre and sal-tartar equal parts, mixed with a little water. The wheel is to be heated red hot and dipped edgewise into cold water. After hardening in this way the wheel is drawn to a dark straw color and the groove polished, first by using oilstone dust and oil with the loop shown in fig. 2, then with a piece of pegwood flattened and the end rounded with a file, using diamantine and alcohol. The sharpened pegwood is used flatwise in polishing. After the groove is polished it is filled with gamboge made into a paste with water and allowed to dry; this precaution is used to prevent the cutting disk, used for damaskeening, injuring the polish of the groove. Frequently we see stem wind wheels frosted, that is, they have a dull, gray, matted look. This is usually done with sifted oilstone dust and benzine on the end of a block of wood, giving the wheel or piece to be frosted a short circular motion. Such frosted wheels, when well and nicely done, are very pretty; but where one perfectly satisfactory finish of this kind is accomplished there will be a dozen failures. I mean to a greater or lesser extent. A beautiful frosting can be made, dissolving clear

white rosin in alcohol. The solution does not want to be thick, as the thinner the solution is the finer the grain or finish produced will be. Take two wide-mouthed bottles, holding about two ounces each, and fill one about half full of rosin broken into dust and small pieces, then fill the bottle with 95 per cent. alcohol and leave it stand, with an occasional shaking, for two or three days; after this pour the fluid portion into the empty bottle and fill up with alcohol. When we wish to frost a wheel, put piece of sharpened pegwood into the center hole (to handle it by) as shown in fig. 3, where *E* represents the wheel and *F* the pegwood; dip the wheel into the solution of rosin and alcohol and set the wheel on a riveting stake to dry, letting the point *d* go into one of the holes so the wheel *E* will lay flat and quiet until dry. The wheel is now to be dipped into dilute nitric acid prepared by mixing fifty drops of acid with an ounce of water. The wheel is allowed to remain in about two minutes, when it is removed and well washed with water. After this the rosin is dissolved off with turpentine and well washed in soap and water. If the first etching is not satisfactory repeat the rosin coat, dipping in acid, and the frosting will be found very even and a little coarser than the grain made by grinding. By rubbing the wheel on a bit of flat cork with oilstone dust and benzine, the dark coat produced by the acid is removed and the surface has a beautiful steel-grey appearance. A mixture of $\frac{1}{4}$ of an ounce of alum and $\frac{1}{4}$ of an ounce of corrosive sublimate in half a pint of water, makes a good acid solution into which to dip the wheel after the rosin coat has been applied. It is to be understood that the process of frosting by acid is not attempted until the wheel is ground smooth and flat, and free from any deep scratches. The solution of alum and corrosive sublimate acts much quicker than the dilute nitric acid, a few seconds answering. Before I leave the subject of cheap chatelaine watches it is well to speak of the stem winding works. These are, as a rule, very badly made and tax the ingenuity of the workman to the uttermost to remedy the countless ills to which (like flesh) they are heir to. The American plan of a tilting yoke for changing over the action from the winding to the hand setting, is usually kept in place by a spring struck out of sheet metal with a die. This method is to be deprecated, as the die breaks up the strength of the steel. Springs cut out in this way should be struck out much larger than needed, and worked down with a file or milling machine to the correct size. To make such springs we need sheet steel softened in charcoal annealing box to cut them out of. Every watchmaker should keep an assortment of such sheet steel of different thicknesses ready softened for just such jobs. In making such a spring, about the best way is to select a bit of softened sheet steel of the proper thickness and soft solder the old spring fast to the steel as shown in fig. 4. The sheet steel plate is shown at *H* and the old spring at *L*. The hole is drilled at *e* and the whole spring given shape while the old spring is attached. A jeweler's narrow saw can be used to saw the soft steel into shape almost as readily as if it was of brass. After it is cut out with the saw it should be brought nearly to shape with a file, and then hardened by placing it between two plates of thin sheet iron formed by folding one piece together like the covers to a book. Such a piece of sheet iron is shown at fig. 5 as if seen endwise. The spring is embedded in a paste of Castile soap between the folds of the sheet iron and heated red hot, and thrown into cold water to harden. It should now be tempered by laying on another piece of sheet iron with a little beeswax, and heated until the beeswax burns off. This device of heating to harden can also be used for wheels.

TO COLOR IRON AND STEEL BROWN.—Dissolve in four parts water, two parts crystallized chloride of iron, two parts chloride of antimony and a trifle of tannic acid, and apply this mixture with a cloth or sponge upon the surface; then let it dry. Repeat the application according to the depth of color desired. This coating fully protects the steel against humidity. The chloride of antimony should be as little acid as possible.

Electricity and Magnetism,*

AS AFFECTING THE PERFORMANCE OF WATCHES.

A brief statement of the general principles of electricity and magnetism with a review of the various ways in which they can injuriously affect the performance of watches, and of the different methods employed for preventing or remedying such effects.

BY "EXCELSIOR."

Continued from page 66, May, 1889.

Only magnetism is injurious. In my last article are described all the ways in which electric currents might be expected to injuriously affect a watch. We have found that only the one last mentioned is of any practical consequence, and that is not through electrical but magnetic action. In other words, we have nothing to fear from electricity, as such, but only from magnetism. We will therefore direct our attention to that branch of our subject.

A magnet, so far as we are concerned, is anything which produces a "magnetic field" around it, *i. e.*, throws out magnetic lines of force in the surrounding space. It may be a bit of lodestone, a piece of magnetized iron or steel, a wire coil with an iron or steel center or "core," or simply a wire conducting a current.

The earth itself is a magnet and we live in its magnetic field. Its magnetism pervades our atmosphere, our houses, our food and our bodies. No man ever got where there was *no* magnetism whatever, unless he surrounded himself with iron or steel. We generally think of the earth's magnetism as "very weak" and not worth our attention. Yet, if we reflect upon what it does, we must admit that it cannot be entirely disregarded. It is that which forces all the compass needles of the earth to point in a certain direction—whether in the surveyor's instruments, the mariner's compasses, the electrician's galvanometers or elsewhere. A force so all-pervading, so unavoidable, so sure and strong enough to do all that—may it not have *some* influence upon the vibration of a steel balance, especially if it is magnetized?

In fact, the whole thing is a matter of degree. Magnetism below a certain strength may be disregarded—not because it has no deleterious effect, but because the disturbance is no greater than other disturbances which are unavoidable, such as jarring, dirt, friction, change of temperature, workmanship not perfect, etc. A watch might perform so poorly that magnetism could not make it any worse—and it would not be worth while to protect that watch from magnetism. On the other hand, the more completely we have removed every cause of error, mechanical or otherwise, the less disturbance can we tolerate from magnetism. Wearers of "cheap trash" need not bother themselves about magnetism, but owners and makers of good watches must and will.

A magnetic field is a space more or less thickly filled with magnetic "lines of force." Without going into any theoretical speculations, I will merely say that the lines of force show the direction in which the magnetism or magnetic force acts. They are not visible to the eye, nor can we feel them in any way, but their presence and direction can be ascertained by scattering iron filings over a sheet of paper, card board or glass, holding the sheet in the magnetic field which is to be explored, and gently tapping it to enable the filings to take the positions to which the magnetism tends to carry them. It is found that they arrange themselves in lines corresponding to the lines of magnetic force. In magnets they extend between the north and south poles.

In the case of a wire conducting a current, we thrust it through the paper, which we hold horizontally, while the wire is vertical, and on tapping the paper the filings arrange themselves circularly around the wire, showing that the lines of force are concentric with the wire carrying the current. When the current is powerful, this magnetic field may extend for many feet from the wire, as stated in my last article, and the entire space is filled with the circular lines of force.

When the current is sent through the wire the magnetic field spreads out around the wire as a sort of magnetic wave, and when the current stops the field contracts towards the wire, and disappears or ceases to exist. If the current is rapidly broken or reversed, this may occur hundreds of times per second. As long as the current flows the magnetic field surrounds the wire, and all magnetic bodies within it are necessarily affected by it.

If we form the wire into a coil we may get the magnetic force of a great length of wire into a small space, and correspondingly increase the strength of the magnetic field. We may suppose that fig. 13

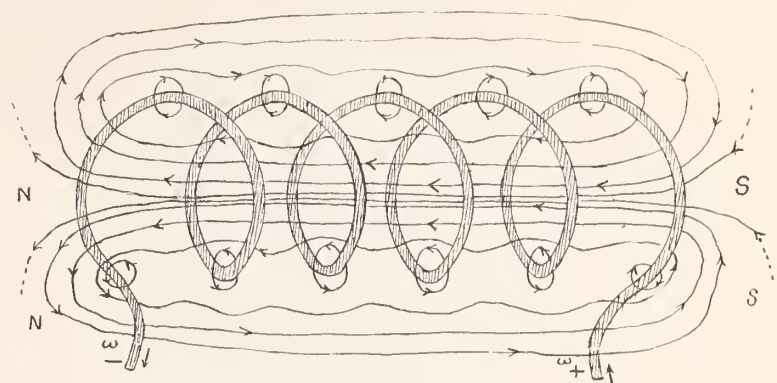

FIG. 13.

represents about what occurs. The arrows at the end of the wire *w* show the direction of the current through it, flowing into the end marked + and out of the — end. The small arrows around the different turns of wire may show the direction of the lines of force around the wire. They are shown only at the top and bottom of the coil. But we may suppose that when the turns are close together the lines of force do not surround each turn by itself, but combine in some way and surround the coil as a whole, as shown by the long arrows. They pass from one end of the coil to the other, inside, and on reaching the end marked *N* they diverge in every direction, umbrella-like, as we may say, and pass back to the *S* end, as shown by the outside arrows, thus completing the magnetic circuit. Every line of force is supposed to be a closed circuit, without beginning or end. It cannot be broken except by being obliterated. That end of any wire coil, around which the current flows in the same direction that the hands of a watch move, is the south end or pole. In fig. 13, the end facing us, at the left of the figure, has the current flowing in a direction *opposite* to the hands of a watch, and consequently it is the north end or pole of the coil, or the end *out of* which the lines of force emerge, as shown by the arrows.

Such a coil and current virtually constitute a magnet. But if we insert an iron rod in the coil, projecting a little at each end, as shown in fig. 13-A, we have a true magnet, called an electro-magnet,

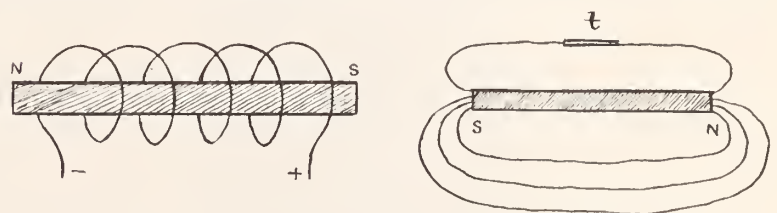

FIG. 13A.

FIG. 14.

because the magnetism is produced by the electric current in the coil and ceases with the current. The magnetism is the same in direction, etc., as before, but it is much more powerful with the iron than without. Air has several thousand times as much magnetic resistance as iron. Consequently the substitution of the iron core in the place of air in the coil facilitates the development of magnetism.

The core need not be straight, but may have any form we wish. If we take a long bar, put a coil around each end (both wound in the same direction and connected together so that a current will flow through both of them), and bend it into U-shape; it will be called a horseshoe magnet. We can tell which is the north or south pole by

* Copyright, 1889, by The Jewelers' Circular Publishing Co.

noting the direction in which the current flows around the ends facing us, by the rule before given.

Permanent magnets. If we put a bar of tempered steel in our coil or coils and magnetize it, it will retain a large share of its magnetism when removed from the coil; but soft iron is magnetic only while the current flows. A permanent magnet is therefore a metallic body whose molecules retain the state into which they were put by being magnetized, and it has its permanent magnetic field around it.

Fig. 14 represents a permanent bar magnet, $N S$. The lines of force pass from S to N in the metal, and from N to S in the air—the direction being shown by the arrow heads on them. Only a few lines of force are drawn in the figure, especially on its upper side, but in reality there may be thousands or millions of them, surrounding the magnet and filling the entire space in its vicinity. The action of the magnet upon other bodies is due to its lines of force passing through those bodies.

The lines of force may be localized, or to some extent concentrated in any particular direction, by offering them an easier path than through the air. For instance, if we place a piece of soft iron i in the magnetic field, as in fig. 15, many more of the lines of force will complete their circuit on that side of the magnet M than without the iron. If i is very close to the poles a large share of them will pass through it. But whether they are few or many, i is then

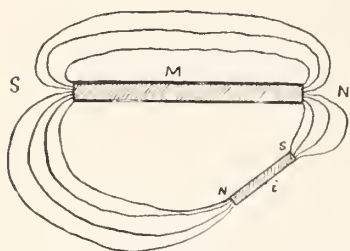

FIG. 15.

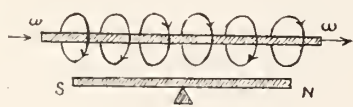

FIG. 16.

“magnetized” in that proportion. The end *into which* the lines of force enter is its south pole and *vice versa*. The poles of i are marked n and s . As two unlike magnetic poles attract each other, i is drawn towards M the same as two distinct magnets would be—only in this case the total magnetic power existing is that derived from the magnet M , instead of that of two separate magnets. If a dozen pieces be used instead of i alone, they will all be magnetized, and will all have the same polar directions as the lines of force of the magnet M . If we ask why i is attracted towards M , we are told that it is due to the tendency of the lines of force to shorten themselves. Hence the “attraction” between i and M is mutual and equal; i attracts M as much as M attracts i . So a piece of unmagnetized iron will attract a magnetized balance as strongly as the balance attracts it—the “attraction” being merely the shortening tendency of the lines of force which pass from one to the other.

The action of magnets can now be studied. I have before said that a current in a wire would deflect a magnetic needle. The needle may be held pointing to the wire as in fig. 20, but the best position is parallel with the wire, and close to it, as shown in fig. 16, where $N S$ is the needle, turning on a point at its center, and $w w$ is the wire, with the current flowing in the direction of the arrows at its ends. When so arranged, send the current through the wire and see if the needle is promptly deflected. According to Ampère's rule: “Suppose yourself placed in the wire, facing the needle, with the current entering by your feet and leaving by your head, then the N pole of the needle will be deflected to your left and the S pole to your right.” By reversing this rule you can find the direction of a current in a wire.

But *why* does the needle turn to the left? Numerous explanations are offered in the text books and elsewhere, but they do not seem to be entirely satisfactory, and I would suggest the following as being very simple and intelligible, and perhaps as reasonable as any. Let the small circular arrows around the wire represent the lines of force

of the current. As they come down on the front or right hand side of the wire they tend to enter and pass through the magnet $N S$. They cannot enter at its N end, because the magnet's lines of force (not drawn in the cut) are emerging therefrom and repel them; but they can enter its S end, because that is the normal direction for the passage of lines of force through it. Its N end is therefore repelled to the left and its S end attracted to the right, till the needle stands parallel with the current lines of force around the wire, when it will be in the best position to afford an easy passage for them. It may not turn quite across the wire unless the current is quite strong, because the earth's magnetism tends to keep it in its normal position parallel with the wire, and opposes the deflecting action of the current to the extent of its power. The amount of the deflection, therefore, shows whether the current is strong or weak.

The action of our magnetism detectors is explained in the same way. The soft iron needle, even if at first held transversely to the magnetic lines of force, is drawn around with its axis parallel with them, because in that position it substitutes iron for air through a greater distance and makes the magnetic resistance of their path so much less. In fig. 14 i is our needle, and obviously shortens the air path much more than it would in any other position. As is seen, it does not point towards the magnet which is acting upon it, but if it is moved longitudinally in either direction, it will follow the lines of force and reach the magnet. If, however, the magnet was quite weak, it might affect the needle enough to make it “point” when near the pole, but not enough when further away. The needle must then be moved only in that direction where it continues to point.

If now we substitute, in place of the magnetic needle, a balance with a magnetized center bar, the current will tend to deflect the balance as it did the needle, and will interfere with its free movement in proportion to its strength, in the manner described in the first article and shown in fig. 1. An unmagnetized balance will be acted upon similarly to our magnetism detectors. And both of them will be affected by magnets according to the law that “unlike poles attract and like poles repel each other.”

(To be Continued.)

Improved Poising Tool.

WATCHMAKERS who have occasionally to poise balances know the difficulties of doing this work with the instruments ordinarily used for the purpose, and also know that they can be certain of the truth only when the poising tool stands truly horizontal, a position obtained only after a number of trials.

A German watchmaker, recognizing the defects of these old instruments, has contrived a new poising tool, which requires very

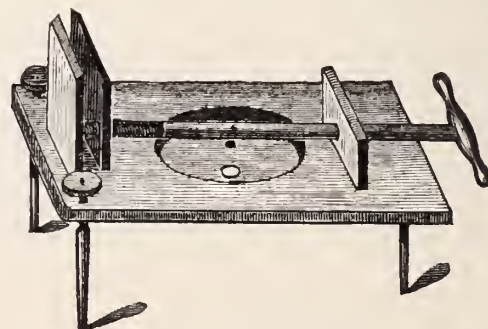

little explanation, as the cut explains its nature. It is about 5 centimeters long and 3 centimeters broad, stands upon three steel feet, two of which can be raised or lowered by milled screws. In the center is a spirit level, truly fitted in; it requires only a few turns either way on the milled screws to set the tool. Other explanations are unnecessary.

The Marfels Watch Collection.

[From the *Deutsche Uhrmacher-Zeitung*.]

Continued from page 78, May, 1889

AFTER having in the last few specimens shown several eminent productions of English and French workmanship, we will divert our attention again to various specimens made by German inventors—pieces distinguished by the great artistic work expended on them. We first are interested in a silver, double case repeating watch of the first part of the last century, the inner case of which is distinguished by its artistic execution. It is shown in fig. 55. The eye of the examiner is charmed by the peculiar, perforated work, the exquisite engraving and the tasteful arabesques, with which the case is ornamented. Very carefully worked is the silver dial, bearing the name of the maker, "Lichtenauer, Würzburg." The well-executed work is distinguished for its very delicate and artistically-perforated and engraved balance bridge. The watch strikes the hour upon a very loud-sounding bell in the interior of the case. We are tempted at this opportunity to mention that according to all appearances gongs were introduced into watches only as late as 1780; we have, at least, never seen either a repeating or an automatically-striking watch of an earlier date which strikes upon a gong.

Of the second very large verge watch, made by the German mas-

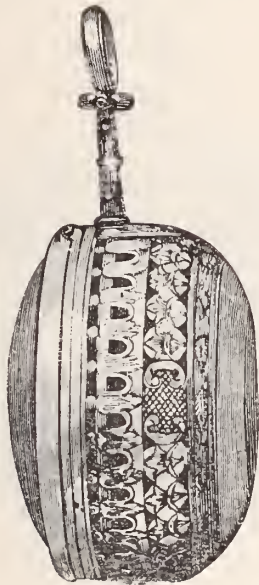

FIG. 55.

ter, Wolfgang Wager, of Wolfbüttel, the movement is the most remarkable part, by reason of its ingenious style of construction, which is represented in fig. 56. It will be seen in the cut that besides the bridges for the balance, there is still another for the third wheel. Both bridges are delicately perforated, not even excepting the foot of the balance bridge. The minute iron springs and ornaments, which decorate the back plate, are also deserving of our attention. The name of the maker is engraved in the same style of ornamentation, so that the whole produces an agreeable impression. The watch was made toward the end of the XVIIIth century.

The great value as a production of art is still enhanced by the considerable value of the metal used for the next watch, fig. 57. It is a heavy gold repeater, of the middle of the last century, the maker of which is not known. He understood how to turn the perforation of the case to practical account: to permit a freer passage to the sound of the bell. At the same time he has created a highly artistic case, the central part of which is decorated with an admirably engraved frieze of delicate floral and animal ornaments. As is common with all perforated cases, this also has an outer case, to protect against dust. The movement, of an English style of construction, has a handsomely ornamented balance bridge, as is customary with all watches of the 17th and 18th century.

To the same category belongs a silver verge watch with alarm, of English make, of the middle of the last century. The excellent *repercé* work (perforated engraving) of the case, calls to mind the previously described piece, and it also has a number of forms of animals. It is doubtless that such watches were very costly, because the marvelously minute execution, for which machine work was utterly excluded, required a very skilful workman and considerable time. The designs alone, of which we have never yet seen two alike,



FIG. 56.

bespeak a great genius and expert sketching, and we are forced to assume that only excellent artists were the makers of specimens of this kind. The silver dial of the watch under examination also is of an artistic execution, and consists, like all the alarm watches of earlier times, of two separated hour circles, the inner one of which is movable for setting the alarm. The name plate contains the name of the maker: Bangiloner, London.

Interesting is also a brass verge repeating watch, of extraordinary dimensions, which is worthy of being mentioned at this place, on account of the execution of the cases; because not alone the inner, but also the outer case is handsomely perforated and engraved. The watch was made about the year 1710. It appears that brass was



FIG. 57.

used by watchmakers very rarely for the making of cases at least. We do not recall the occasion of our having seen a second watch of that period with a brass case; in by far the greatest number of instances the old masters used bronze or silver. The piece under inspection has already two hands; the bridge is of the English style of ornamentation. An engraving upon the back plate tells us that it was made by Johann Heinr. Klein, of Copenhagen.

To the previously described high double cased watches with perforated inner case, also belongs a high verge alarm, silver watch.

The copiously perforated and artistically executed broad frieze, which ornaments the inner case of this watch, is surrounded upon both sides by an engraved scale ribbon of most enchanting effects. The ornaments of which the frieze is formed, depart essentially from the general routine, and, beside this, they attest to the great diligence displayed as well as to the exceedingly rich imagination of the maker, who understood how to use foliage ornaments to the height of their



FIG. 61.

effects. The watch has only one hand, which indicates the time upon the artistically engraved silver dial. The movement itself is of a substantial construction, and was made by B. Dukamet, in London, about 1690.

Our interest is next engaged by the curious dial of an old French verge watch, fig. 61. It is of bronze gilt, and tastefully *ciselé*. The figures are burned in upon small enamelled plates, which are fastened upon the dial, and contribute not a little to the admirable impression of the whole. Another ring formed also of little enamel plates, separates the hour circle from the center of the dial, and are specially handsome upon the *ciselé* work. The highly constructed work is executed with great care. Especially handsome are the pillars and



FIG. 63.

bridge, by reason of their artistic execution. The latter is ornamented by one of the beautifully designed perforations which make the verge bridge a preferred article by art connoisseurs. This watch was made by Cogniat, in Paris.

In the next piece we find an ingenious departure in the ornamentation of the balance bridge. When opening the watch, a high English verge with finely engraved silver dial, the examiner is surprised

by an enamel portrait of a young lady. The watch made by Amtram, in London, is furnished with date movement, the figures being visible through an opening in the dial. It appears that this style of ornamentation was occasionally resorted to, because the collection contains a second specimen of the kind—a very high French verge watch, with an admirably engraved silver dial, the bridge of which also contains an enamel picture, of a spicy subject.

One of the most valuable specimens of the collection, a veritable masterpiece of the art of enameling, is the gold hunting-case watch, the front and back of which are shown in figs. 63 and 64 and belonging to the 17th century. The enamelings upon both sides of the case exhibit such a charming display of coloring as is but seldom found. It may be safely asserted that no enameler of the present day is capable of producing such an effective piece of work. The simple wood cut is unhappily capable of presenting only an inferior representation of the beauty and wealth of the execution.

The enameling upon the front cover, fig 63, represents a scene from the Iliad; the Goddess Thetis, commanding Vulcan to forge weapons for her son Achilles. Upon the back cover is also shown a scene, in the same unsurpassable style of work. The rim of the case is ornamented with delicate miniature landscapes. Upon the inner side of the cover are also found excellent enamel inlays, representing landscapes, which from their manner of execution, can worthily take rank with the productions of a Vander Neer or Ruysdael. The dial with only



FIG. 64.

the hour division, is also enameled and painted. The admirable exterior causes us to suspect a similar movement; the small oval bridge, underneath which vibrates a balance without spiral spring, is charmingly engraved. The master maker of this piece is De Bauffre, Paris, who made it doubtless about the year 1670.

In order to show how scarce and in what great demand specimens of this kind are, and what art value they have is seen from the statement that it cannot be purchased from antiquarians at less than several thousand marks, and such specimens are not found in other private hands. Even not considering the price, a collector who succeeds in acquiring such a piece, may consider himself fortunate, because if not thrown on the market by an accident (the death of a collector, etc.), he may be on the alert for years without enjoying the opportunity ever of seeing such a specimen.

There is a verge watch, dating to the middle of the last century, and belonging to a kind but very rarely found—the *vieux Saxe*. The case is of porcelain, painted and mounted in gold, is of rare beauty. The many hued flowers grouped in bunches upon the white ground create a most agreeable impression. Even the bezel is of porcelain, painted and rimmed in gold. The movement itself possesses no noteworthy alterations. The maker is unknown.

The next following piece again shows a specimen of precious chased workmanship. It is a double case English verge watch, the

outer case of which is shown in fig. 66. The back bottom of this masterpiece has in its central part a mythological scenery, "Leda with the swan," in a perfect style of execution. This central part is surrounded by four most carefully *cisellé* heads, which again are framed in by excellent arabesques, which harmoniously confine the figures and heighten the total impression. The movement, also, is very carefully gotten up and stands well in harmony with the artistic execution of the exterior; thus, for instance, the balance bridge is very handsome, its perforations representing a hunting scene. The engraved silver dial is in keeping in all its style with the other parts. The watch was made in the beginning of last century, and is apparently French work. Its maker is unknown.

Less interesting by reason of the artistic execution of its case than by the very complicated dial, fig. 67, is the next watch. As will be seen in the cut, it contains three small, very carefully engraved silver circles with numbers, while between them, toward the rim, are three openings. The hours (the minute division being still wanting) are shown upon the lower dial with ordinal figures, while the other two circles, as well as the openings, indicate the date, day of the week, the four divisions of the day (forenoon, afternoon, etc.), month, zodiac, and phases of the moon. This watch was made apparently about the year 1680 by the English watchmaker Javat, in London.

The next, an alarm watch, fig. 68, also made in the 17th century, has a remarkable dial. At first sight it would appear that the num-



FIG. 66.

bers, upon square silver plates, are located in place at random, but at closer inspection, a certain symmetry is discovered, and it must be confessed that this arrangement is interesting, if for nothing else than its originality. The hour hand (the watch has only one hand) is firmly united with the alarm disc, which is perforated into handsome arabesques. Upon the back plate, close to the handsomely engraved bridge, stands the name of the maker, "Leonh. Bommell Nürnberg." The watch was made about the end of the 17th century.

This collection still contains many pieces, each of which is highly interesting, the description of which, however, would make this article too long. We will therefore simply point out several of them that are worth being examined by the visitor:

A most excellently executed repeater with cylinder escapement, stone cylinder and parachute; of an original style of construction.

A cylinder repeating watch with gold, very peculiarly cut-out wheels, made by L'Epine in Paris.

An interesting watch with comma escapement, with gold wheels entirely perforated, by the same maker.

Three verge repeating watches with movable figures upon the dial, such as harvesting man and woman, two amorettes, two negroes, each of which, in repeating, strike upon a bell.

A fairly large quantity of fine English verge movements with artist-

ically engraved silver dials and bridges; this collection contains a specimen in which a crystal plate is inserted in the balance bridge.

We cannot close this article without saying a few words about the Marfels collection of verge bridges, which subject has in general been much neglected. It is necessary to have seen this collection, consisting of about 400 picked specimens, in order to understand why connoisseurs prize this collection so highly. And it is no wonder, because these 400 pieces have been selected from among about 60,000, and not alone Germany, but the whole of Europe has contributed

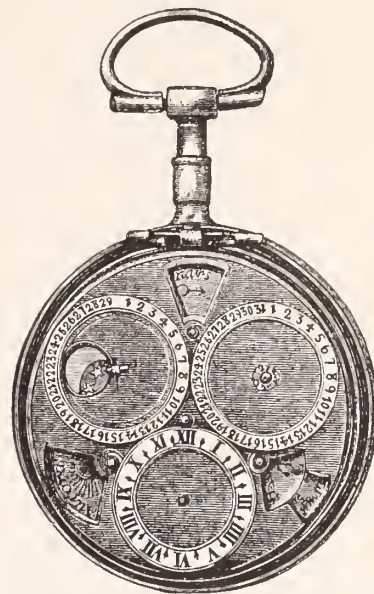

FIG. 67.

toward it. In it we meet with samples which in point of beauty and size are but rarely rivaled, never excelled.

We wish to show at least two specimens of verge bridges in natural size, remarking at the same time that they have not been specially selected, but taken at random.

Various offers from abroad, it is said, have already been made to Mr.



FIG. 68.

Marfels, for the purchase of his collection, but it appears that he has refused every offer made him.

In conclusion, THE JEWELERS' CIRCULAR desires to convey its thanks to Mr. Marfels for his kind permission to the former to copy the article and for the excellent lithograph volume of the collection sent.

[THE END.]

Center-Seconds Chronograph Watch with only One Barrel, Beating Full Seconds.



IN THE *Revue Chronométrique*, M. Claudius Saunier describes a very ingenious arrangement for a chronograph watch, with but one barrel, beating full seconds, invented by M. Ratel. As will be seen from the annexed engraving, communication is made between the arbor of the fourth wheel and the center arbor, by means of three wheels, as in the ordinary chronograph. This second train is composed as follows: The wheel *x*, carrying the seconds hand, engages with the wheel *A*, the last-named being shown in elevation at *A'*. This wheel *A* is loose on the fourth wheel arbor. The fourth wheel *B* is shown by a dotted circle in the plan, and in elevation at *B'* with its pinion *u*. A bar, *s*, carrying a spring detent, *c*, is fixed in position on the wheel *A*, and acts with it. Under the bar *s*, on the pinion of the fourth wheel, is the ratchet *n* of 20 teeth, which engages with the head of the spring detent *c*. The wheel *A* not only engages with *v*, but also with a pinion of 8 leaves (*h*), and on this pinion is riveted a wheel of 48 teeth (*D*), which engages with a pinion of 6 leaves (*E*), with a flirt. This flirt takes into a pinion of 6 leaves (*f*), fixed to the scape wheel pinion.

The action of the seconds train is as follows: As the fourth wheel

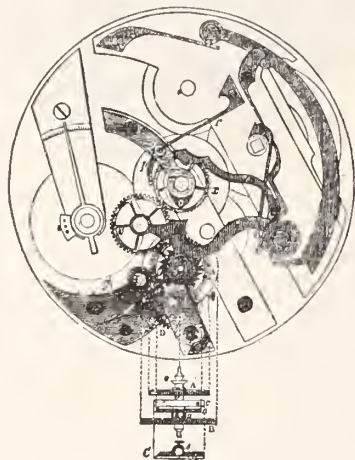

travels, the ratchet *n* arms the detent *c* by putting it in tension, and the detent fixed by means of the bar *s* to the wheel *A*, and so drives the seconds train, which, however, is controlled by the flirt.

When the flirt escapes from one leaf of this pinion *f*, the detent makes an advance of one tooth of the wheel *A*, and the center seconds hand moves through one-sixtieth of the circumference of the dial. It is understood that the watch has an 18,000 train.

The detent is always armed with the force accumulated during 15 vibrations. During the going of the watch, if the center-seconds is detained, the detent, when sufficiently armed, simply slips on to the next tooth of the ratchet, and is always ready to resume its function, when required.

The starting, stopping and returning to zero, the arrangement is none the less simple. For starting the chronograph hand, a push of the pendant brings *v* into engagement with *x* by means of the pivoted lever. A second push of the pendant withdraws *v* from *x*, and the hand is stationary. To return the hand to zero, a third push of the pendant allows the lever *z* to press against the heart-piece *v*. These movements are the same as in the ordinary chronograph. The click *p* with the spring *r* insures the stopping of the head level and steadily on the seconds.

A Good Way to Clean a Mainspring.

THERE are several methods for cleaning and mounting a mainspring, but the following ranks with the best in use among good watchmakers. Let us suppose we have a watch that has run twelve months or more. After taking the watch down, first examine the mainspring by taking off the cap of the barrel, carefully remov-

ing the arbor, then holding the barrel in the thumb and fingers of the left hand, lift out the inner end of the spring with small round nose pliers, holding the thumb and fingers in such a manner as to allow the spring to uncoil itself from the barrel in a gentle manner into the hand, and if sound and of the right strength, proceed to clean it with a piece of domestic (a clean soft rag is preferable, as it is free from starch and other foreign matter calculated to injure steel). Holding the cloth or rag in the left hand and the spring just as it has come out of the barrel in your right, gently move it back and forth, holding two or three of the coils between the thumb, first and second fingers, pressing the coils slightly over with the ball of the thumb (not nails), so as not to materially change the natural curvature of the spring in any way during the operation. In this way the entire spring can be cleaned, with the exception of a small portion of the inner coil, which can be cleaned by using a corner of the rag, applied with a piece of pegwood, or by a slight brushing with a brush used for this purpose. A first-class spring (and no watchmaker should use any other if he values time and reputation) thus cleaned, with proper space in the barrel, and with the arbor free, of proper size, and a liberal application of watch oil, but not flooded with it, turned up to its proper capacity will give out its full force for one or two years, at least, without breaking, rusting or becoming gummy and foul.

Pallet Lockings.



IN RESPECT to the pallet lockings, the equality of sharpness of draught inward is readily judged to be about equal by trial—some persons try them by placing the guard pin against the round edge of the roller and gently putting the peg on the escape wheel. But the equality of their draught inward does not quite prove their equal resistance to the reciprocated force of the balance, nor does the writer know of any way to prove when they are so, strictly, but he will make some remarks about them. It is to be observed that the two lockings are at unequal distances from the center of the pallet, and also that with deeper depths the wheel drops further under the inside locking, so that in unlocking the wheel has to be moved further back to get the locking out from under the tooth; still, as the radius to the inside locking is the shortest, therefore the long arm of the lever bears a greater ratio to that shortest pallet radius, and although the inside locking of itself may be a trifle the hardest, yet it may not subtract any more velocity from the balance in unlocking than the outside one; and, indeed, if the inside locking of itself was as easy to unlock as that of the outside we should then be certain that the resistances to the force of the balance would be unequal, as the two radii to the lockings were unequal. Unequal radii must have unequal resisting lockings to subtract equal portions of velocity from the same reciprocated force of the balance.

In light pallet depths the wheel has only to be moved back in the locking a mere trifle, but in very deep depths or long run to the bankings, the wheel has to be moved back a good bit. It is the moving back of the wheel to get the locking out from under the tooth that causes the principal resistance to the force of the balance, for if there were no motion backward of the wheel the unlocking would only be a frictional resistance, like in a regulator clock; but this is impossible in watches, for there must be a detachment by draught inwards sharp enough to free the guard pin without any hesitation, or else there is danger that the vibration of the balance is frequently interfered with, which, in some cases, will stop the watch.

All pallets that make equal arcs by the two workings have, and must have, the deepest hold of the outside locking. Suppose the depth hold to be such that each of the pallets make an arc of 3° in the unlocking, it is easily seen that 3° of the larger outer circle which

the pallets describe is a greater space than 3° of the smaller inner circle, and the piece of stone which must enter the wheel is the greatest on the outside locking—and if pallets were made to draw off equally, that depth at which they would do so must be planted precisely or they would be unequal in the draw off. As a rule, it will be found that if the wheel just catches a tripping hold of the outside locking and just ships the inside locking, when tried in a depthing tool before closing the tool to the depth, the unlockings will draw off pretty nearly equal when in at the depth, provided the depth is not very deep.

The Movable Stud.



THE GREAT objection to the ordinary balance spring lies in the distance of the center of the balance cock from any one of its points of fastening; this causes the body of the spring to crowd to one side in vibrations of any extent. A change of form takes place, which opposes the progress of the isochronal development.

This defect may be overcome by not fastening the spring to the bridge, but to the end of a straight spring screwed with a foot upon the plate, as shown in the accompanying cut. This construction is known by the name of "spring stud," or "movable stud." By the vibrations of the balance the stud bends, and when the balance spring closes, its end approaches towards the center, while in the opening of the former it withdraws. This disposition, gotten up by Young & Hardy, favors the isochronal development of the spring to a high degree.

The difficulty is to find the exact proportions. It is evident that

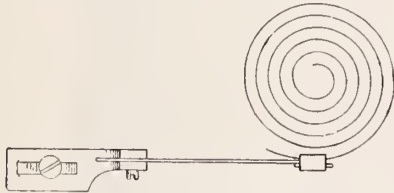

by a given balance spring the spring stud must comply with certain conditions of length, thickness, flexibility, etc., which until now could be established only by experiments. Besides this, strictly considered, the head of the stud must have almost no weight, so that its elasticity alone would operate, and its weight would not enter into account as a different power, between the vertical and horizontal positions.

This arrangement, says Cl. Sannier, is still too new to express an opinion on its merit. C. Frodsham, of London, introduced a flat balance spring with a spring stud in a marine chronometer, and it has been shown that this chronometer was one of the best he ever made. Raby, of Paris, also used the spring stud in watches, and expressed great satisfaction as to their performances.

Japan's New Patent Laws.



THE Japanese Government has just adopted a system of patent laws unsurpassed in completeness and simplicity by those of any other nation. The fact that they are designed entirely for the benefit of Japanese subjects, not a word being said about the inventions of foreigners, shows that there must be some originality in this wonderful people, else why provide a means of protecting new discoveries?

The new patent laws of Japan are worthy of brief reference. They provide for the issue of patents to all inventors whose discoveries are beneficial to or calculated to improve existing processes of

manufacture. Exception is made in the case of articles of food, drink or fashion, which cannot be patented, and medicines. The latter strikes us as a very strange exception, so large a proportion of the patents issued in most countries now-a-days being granted on all sorts of nostrums. The Japanese Government holds that if a medicine is of real value, it is wrong to withhold it from suffering humanity; if it is valueless, the Government has no right to do anything that would enhance its value as a medium for the swindling of the public. No patents can be obtained on articles in use prior to the application, and every invention brought before the public before protection has been secured may be imitated. Where patents are likely to be of public value, they may be claimed by the government and the inventor compensated for their use. The Bureau of Patents is under the supervision of the Minister of State for Agriculture and Commerce, and the commissioners command the services of two judges in deciding doubtful cases, etc. Patents are granted for five, ten or fifteen years, according to the fee the patentee is willing to pay, the first costing 10 *yen*, the second 15 *yen*, the third 20 *yen*, with preliminary fees of 12 *yen* in each class.

In connection with the Bureau of Patents, there is a special department in which, for a small fee, a valid trade-mark may be registered for twenty years, and there is also a Bureau of Designs, in which new designs relating to shape, figure or color for industrial articles may be registered by their originators for exclusive use. The cost of such registration is, for three years, 1 *yen*; for five years, 2 *yen*, and for ten years, 8 *yen*, with a moderate scale of fees for the registration, sale, transfer, revision, etc., of designs.

Owing to the laws of Japan being inoperative as regards foreigners, it is impossible for the latter to take out Japanese patents, and the value of such protection as they would afford, in view of the rapid progress Japan is making in the industrial arts, makes it exceedingly important that they should benefit by this patent system. As it is, any article sent for sale to Japan can be imitated by Japanese workmen, no matter how stringently protected in every other country granting patents, and as the Japanese advance farther in industrial development this will soon become a serious question. Of course, it would be folly to request Japan to give us the benefit of her laws to this extent and leave us to our own legislation in every other, as provided by the present treaties, under which the various nations maintain their own courts of justice in Japan, in which all cases concerning their subjects must be tried.

The adoption by the Japanese of a constitutional form of government and of a patent law system are destined to prove important factors in the abolition of these treaties, which are regarded by intelligent people as, at best, discreditable memorials of a policy of oppression that has been too long maintained against progressive Japan.

A FATEFUL RING.—A curious story is related from Madrid in explanation of the misfortunes which have lately afflicted the royal house of Spain. It appears that the root of the mischief is a fatal of quite mediæval deadliness. The late King Alphonso XII. gave it to his cousin, Mercedes, when he was betrothed to her, and she wore it during the whole of her short married life. On her death the King presented it to his grandmother, the Queen Christina. She died very soon after, when it was passed to the King's sister, the Infanta del Pilar, who at once began to sicken and in a few days breathed her last. Alphonso then handed it to his sister-in-law, Christina, the youngest daughter of the Duke of Montpensier but in three months she was also dead. His Majesty now resolved to retain the baleful jewel in his own keeping, but he too, soon fell a victim to its mysterious malignancy. By order of his widow it has now been suspended by a chain around the neck of the statue of the Maid of Almudena, the patron saint of Madrid.

A Remarkable Musical Clock.

Made by Eardley Norton, of London, Eng.

A VERY curious musical clock is in the possession of Mr. J. E. Whiting, a jeweler of Andover, Mass. It was at one time owned by Mr. Whiting's grandfather, Edward Savage,* a portrait painter of New York, and was exhibited by him in his museum of curiosities. After the sale of his museum to the New England Museum, (now Boston Museum) this clock, in company with a number of other things, was moved to his home in Princeton, Mass. Since the death of Mr. Savage, which occurred in 1817, the clock has been handed down among his descendants until it became the property of Mr. Whiting in 1865. It is about 28 inches high, and is in solid mahogany case, veneered with mahogany and elaborately trimmed with brass. It plays twelve tunes on a chime of sixteen bells at intervals of three hours, chimes every quarter-hour on eight bells, and strikes the hour on a large bell entirely separate from the chime. It has a porcelain dial with hour and minute hands, and also a hand indicating the day of the month. Above the time dial is a small dial in the shape of a half-circle, and around the outside edge of this are arranged the names of the tunes played by the clock; on this dial is a hand pointing to the tune to be played. There are also two



smaller hands by which the clock can be made to strike or be silent, chime or not chime. The names of the tunes played are: Fandango, Gaita Gallega, Minuet, Patty's Mills, Minuet-Gavot, Harvest Home, March, Nancy Dawson, Dance, March, Hymn. It can, by a tassel on each side, be made to repeat the last quarter chimed and the last hour struck, and the last tune played, at any time desired. The movement is made of brass, and is comprised of four trains for time, strike, chime and music; each train has separate barrel, fusee and chain. It has a dead beat escapement and is nicely polished and engraved throughout. The name of the maker, Eardley Norton, and the number of the movement, 1339, is engraved on the back plate. On the back of the dial are scratched the names of the clockmakers who have repaired it, and also the dates of repair, as follows: Jan. 24, 1781, cleaned, Daniel Balch, Newbury Port; August, 1787, cleaned, R. Pope; Dec. 21, 1826, mainspring, E. Sutton; 1866, J. E. Whiting, Waltham, Mass.; 1868, J. E. Whiting, Andover, Mass.; 1889, J. E. Whiting, Andover, Mass. Mr. Whiting has spent a great deal of time and money in getting it back as near its original state as possible, and having succeeded beyond his expectation, is desirous to learn what he can of the history of the clock or its maker. Any information in relation to either would be highly appreciated and thankfully received.

* April, 1889, *Century Magazine*, page 864.

Preparing for Wet Coloring.

THERE are several methods of preparing work for wet coloring, each operator adopting the one which suits him best and appears to claim an advantage over the others. We do not intend to assert that there is any particular advantage in the adoption of any particular process. The main principles are thorough polishing (this need not be so much the case as for dry coloring, though it is of great importance) and cleanliness, the latter element being very essential in the production of a good color. The operator cannot be too careful in enforcing these two conditions.

Some persons prefer to color from the black anneal; others to boil for a time in nitric acid pickle; others, again, after the work has been well annealed, boil out in sulphuric acid pickle, and afterward in clean water. In adopting any of these plans, the method is that after the work has been well polished by means of the finest materials and washed out, it must be placed upon an iron or copper pan and heated to redness over a clear fire, the latter proceeding being of importance. If it appears greasy in the interstices and it is desired to color it black, it should be boiled out again and annealed; it may then be placed aside to cool, and afterward suspended upon the wires usually employed for this purpose. In the work of re-coloring

articles it is by far the best plan to anneal them. Where this can be done, boil them out and again anneal them, which is easily performed. It is an economical plan to re-color goods of this sort in old color, which should always be preserved for the purpose. If this appears dry, or nearly so, when put into the pot, add one ounce of acid and one ounce of water; if tolerably liquid make no addition whatever, for, in some instances, and especially where the alloys contain a great proportion of copper, the weaker the preparation the better and brighter is the color produced upon the work.

Finishing the Work.—After the process of wet coloring, it is absolutely necessary that the work should go through another operation, that of "scratching," which consists of submitting it to the revolving action of a circular brush of fine brass wire, mounted upon a lathe after the manner of the round hair brushes used in polishing, and upon which a weak solution of ale is allowed to run from a small barrel with a tap to it. This removes any dull color that may be upon the work and gives it a perfectly bright and uniform surface. Frosting is effected by keeping the points of the wires of the brush quite straight and running the lathe very fast, just letting the ends touch the surface of the work; to do this accurately requires great practice. After this process has been performed the work must be well rinsed in either hot or cold water, and finally dried in warm boxwood sawdust, which must not be allowed to burn or char in any way; if so, the color of the work will be much damaged and its beauty marred. A soft brush will remove all traces of sawdust from the interstices of the articles which have passed through this operation.



WORKSHOP NOTES

QUARTER SCREWS IN TIMING.—In timing a watch, when withdrawing or inserting the quarter screws it is not necessary to take the movement out of the case; simply hold the balance rim at the place, where the screw to be operated on is placed, with a pair of tweezers, and make the operation in such a manner as to exert no lateral pressure on the balance rim or staff pivots. Very delicately and sharply filed screw drivers are necessary for this job.

POISING TOOL.—A very good poising tool can be made by adapting to one end of the ordinary depthing tool two new centers of steel wire, about one-half inch of the inner end of each of which is filed away beyond the diametrical line. Harden and polish these ends, and they will present, when properly fastened in the tool by the set screws, a very nice sharp angle on which to poise the balance; the adjustment for the length of staff is, of course, made by the screws which open the tool.

REPAIRING A POCKET CHRONOMETER.—The repairer who finds that the chronometer sets, should try if the angle of impulse is too great for the amount of vibration of the balance. Should there be any inequality in the wheel teeth and the escapement trips, a considerable amount of drop on to the pallet may be given; this is done by moving the rollers nearer together, and by turning the balance round and reversing the action, the amount of drop and engagement of each tooth on the impulse and the locking stone may be tested.

WATER-RESISTING CEMENT.—A good cement, which completely resists the solvent action of water, may be prepared by the following process: From 5 to 10 parts of pure, dry gelatine are dissolved in 100 parts of water. To the solution is added about 10 per cent. of a concentrated solution of bichromate of potash and the liquid kept in the dark. When articles joined by this cement are exposed to the light, the gelatine film is acted upon, the chromate being partially reduced and the film of the cement becomes tough and durable.

EQUIPOISE.—Characteristic of the lever movement is its fork, which is solidly united with the pallets. At its other end, the fork is provided with a prolongation for establishing a counterpoise; nevertheless, it may be observed in many watches that, in spite of this provision attached to the fork, this body is far from being perfectly and evenly balanced upon its axis. As may be supposed, this absence of equipoise prevents the regulating in the horizontal and vertical positions, and before the timer expends any work it is necessary to place anchor and fork into the balance tool, and to establish the equipoise in a suitable manner, in case it does not already exist.

THIRD PINION.—In those calibers of movements in which, from the reversed position of the center wheel, the power is received and transmitted from opposite ends of the pinion (as in the case of the third wheel in the ordinary foreign or barrel movement), one commonly finds, after the watch has been going for any length of time, the upper pivot considerably worn out or cut. This proceeds in many cases from the pivot in the first place being too small to withstand the necessarily great pressure. In addition to this, the leaved portion of the pinion having been so high as to meet the center wheel with safety, renders it difficult to get a sufficient shoulder to the pivot. If, in addition to this, there is an insufficient hollow, and that but roughly cut, it is hardly to be wondered at if the oil disappears rapidly and the pivot becomes cut. In repairing the pivots it will generally not be sufficient to turn out the works and re-polish. If this is done it often becomes cut again very quickly. It is much better to replace the pivot with one of the original size, and at the same time see that the extreme corner is clearly sloped off, and that the hollow is somewhat large, deep and clearly cut.

MALLEABLE BRONZE.—Dronier claims to have discovered a simple method for rendering bronze as malleable as iron, copper, etc. This consists in the addition of a very little mercury, from $\frac{1}{2}$ to 2 per cent. It seems to act mechanically rather than chemically. The mercury may be combined with one of the metals with which the bronze is made before they are combined, by pouring it into the melted metal and stirring it well; or it may be put into the melted copper along with the tin, or just after the latter has been added, or an amalgam of tin stirred into the melted copper.

CURB PINS.—Some watchmakers have the pernicious habit of bending the curb pins, in case they do not exactly correspond with the position of the balance spring, to suit the occasion. It is evident that the pins will then no longer stand at right angles, but obliquely, to the plane of the spring, and the faulty result occasioned by such irregular touching of the spring at each vibration can easily be imagined. If it is impossible to avoid this bending, then the pins should at least be brought back to a vertical position by being bent with an elbow. It is also advisable to the watchmaker to closely study the different systems of regulators used by the different manufacturers, because for a close regulating it is of great importance to have even the smallest motions of the regulator under perfect control. If a close rate is demanded, the curb pins must be kept free from filth and oil, because a slight gluing of the spring at these parts is apt to generate other irregularities.

FACTITIOUS GOLD.—A metallic alloy very extensively used in France as a substitute for gold consists of 100 parts of pure copper, 17 parts of zinc, or, preferably, tin, 6 parts of magnesia, 3 to 6 parts sal-ammoniac, $\frac{1}{8}$ part of quicklime, and 9 parts of cream of tartar. These ingredients are mixed as follows: the copper is melted first, the magnesia, sal-ammoniac, lime and tartar are then added separately and by degrees in the form of powder, after which the mixture is diligently stirred for about one-half hour to be certain that it is thoroughly intermixed; the zinc is then introduced in small grains by throwing it on the surface and stirring it until fused; this being effected, cover the crucible and maintain the mass in fusion for about thirty-five minutes; skim the surface, and the alloy is ready for casting. It will be found to have a fine grain, to be malleable, and take a fine polish. It is an excellent substitute for gold for many purposes, as it does not easily corrode. When tarnished, its luster can be restored with a little acidulated water. The alloy will be more brilliant if tin is used instead of zinc. It is very popular in France.

THE REGULATOR.—The regulator performs an important function in timing. Many a young watchmaker has tried in vain to reduce a watch to a regular rate, simply because he had not bestowed sufficient attention upon the regulator. It is well known that it should move with gentle friction, neither too hard nor too soft. Equally well known is the fact that the outer spring coil must lie exactly in the circle described by the curb pins. To some, however, it appears unimportant whether the curb pins stand far apart or close together, yet this difference is productive of many irregularities in the rate. The curb pins must never squeeze the balance spring, else it would be forced into an unnatural position with each moving of the regulator. Equally objectionable is an undue width of these curb pins. Let us suppose them as being too wide, with the balance spring lying free between them; it stands to reason that with a small vibration the entire length of the spring is in action, regardless of the presence of the regulator; the spring would then only touch the curb pins in more extended vibrations, and an acceleration would take place. If, however, the regulator fork is too wide, and the spring is placed against one of the pins, it will not, in small vibrations, proceed from the pins, and approximately operate in such a manner as if its length only reached up to the pin. In its larger vibrations it will proceed from the pin, and the vibration will be retarded.



PERPETUAL MOTION.—This fantastic idea, which was once supposed to be able to perform the most astonishing of services, still counts its followers. More than 100 patents have been taken out in England and France during the last 20 years, although science demonstrates that the idea is a piece of nonsense, because power must be where labor is expected.

THE FORK.—A well preserved fork with five prongs, one of which is broken off, was recently found in a Roman grave at Pæstum, and sent to the Museo Nazionale of Rome. This shows that forks were used by the Romans, who called them *fuscinula*. The introduction of the fork is generally laid in the fourteenth century, when it is first mentioned in the inventory of King Charles V. of France (1379). But the so-called forks of that time were small affairs, with two or three prongs, while the other end was a spoon. In England they were first used under James I.

GIGANTIC DEVELOPMENT OF THE SWISS WATCH INDUSTRY.—Alexis Favre, of Geneva, the reporter of the section "horology," in the National Exposition in Zurich, gives in his interesting memorial a history of Swiss watchmaking, which contains the following statements: Watchmaking is one of the branches of industry in Switzerland that may be called national. It arose in the middle of the fifteenth century in Geneva. In 1587 the watchmakers formed a separate guild; one century afterward Geneva already contained 100 master watchmakers, who employed 300 journeymen and made 5,000 watches annually; in 1760 there were 800 masters with 4,000 workmen. At present, Geneva contains about 300 factories and workshops, with 10,000 workpeople. In the mountains of Neuchatel we find the first watchmakers near the end of the 17th century; in 1752 there were 466 watchmakers in Chaux-de-Fonds; in 1802 the entire canton contained 4,000, while at present 15,000 people are engaged in this branch. In the eighteenth century this industry was introduced into the Vallee de Joux, in Sainte Croix, as well as a few localities of the Canton Berne; in the latter, however, it began to develop only in this century. In Purrentruy, for instance, where it was introduced in 1843, about 3,000 people are engaged in it at present. In Biel the watch manufacture began in 1847 with 7 people; at present this number has grown to 3,000; in 1851 there were 4, but in 1886, about 100 manufacturers. In round numbers, 20,000 workpeople are engaged in the making of watches in the whole Canton Berne. In the Canton Solothurn the first factory was erected in Granges in 1840; it now counts 16, with more than 2,000 workpeople. The small village Waldenburg, in the Canton of Baselland, has among its 900 inhabitants 400 watchmakers; the industry was introduced here in 1850, with the assistance of the community. The Valley of the Rhine also contains watch factories. In 1868 a workshop was opened in Schaffhausen, which employs at present 150 watchmakers. According to Birkhäuser's year book, Switzerland contained at the beginning of 1886, 1,363 steeple and house clock manufacturers; 1,223 watch factories; 439 case factories; 397 watch material factories; 171 watch stores, etc. The number of the persons occupied in this industry amounted to 29,189 men and 14,716 women, according to the census of 1880; indirectly supported by it were 17,150 males and 30,383 females, so that a total of 93,357 persons were supported by the Swiss watch manufacture. Of this, 10,873 working people of both sexes worked in 751 factories. The value of the productions of this industry can be readily understood from the fact that alone in 1885, watch cases to the value of 78,848,000 francs were exported. Of this, cases to the value of 20,288,000 francs went to Germany, 16,996,000 francs to England, etc. Also the United States still obtains a considerable supply of cases from Switzerland.

ENTERPRISE.—A French jewelry drummer intends to travel his route per tricycle. The vehicle is built to carry about 30 kilograms (66 lbs.) of goods.

FINGER RINGS.—The old style of finger rings, with a setting containing a compass, is now being brought into use by electrical engineers. Held near a line-wire, the movement of the compass shows at once whether a current is passing.

HOW ROMANTIC!—Miss Kate Bishop, an actress in Australia, wears a silver bracelet on the left arm night and day. Her only sister locked it there before she sailed for America to get married. The ship went down with all hands, and the key is with the drowned girl.

THE WATCHMAKER'S ART.—A European horological journal says that "A thorough mastery of all the difficulties incident to watch repairing can only be acquired by a thorough conception of the correct theory of the escapement, and the variations from it which occur in actual practice, and the manner in which one error is made to compensate another. Owing to the microscopical character of watch work, true theory has often to yield to practical necessity, and watchmakers are beginning to realize that simple forms of watches give a satisfaction too often denied to the more complicated."

THE TIME-BALL.—When Pope Alexander V. drew his celebrated dividing line of the world, science was still so helpless that this line could not be transported upon the earth. At the conference held at Badajoz, Spain, by the Spaniards and Portugese, the latter stated the distance from the Moluccas to be 137 degrees; the former, however, had computed it to be 183 degrees. The science of our days shows that the former counted 13 degrees too little, the latter 33 degrees too much. Even one hundred years later an astronomer was able to approximate the geographical length between Cadiz and Constantinople to three degrees of the actual truth. Philipp II., of Spain, therefore, offered a prize for a simple method for determining longitude. The marine nations—the Dutch, French and English—soon followed this example. The British Parliament, for instance, offered a prize of £20,000 for determining the longitude at sea within one-half degree, and these rewards stimulated the inventive genius of the age. The celebrated Tobias Mayer rendered famous his name by his improved ephemeris of the moon, which assisted largely in determining the longitude fairly exact, and his widow received part of the prize offered by the English Parliament. As is well known, the simplest method of ascertaining longitude at sea is by the assistance of a good chronometer, because geographical length is nothing but the difference between the earlier and later noon of two localities. If one, therefore, carries a correctly-going timepiece either to the east or west, he may, by the occurrence of noon at that locality, compared with the rate of the timekeeper, determine precisely the eastern or western longitude of a place. Harrison succeeded in making chronometers that could be used for this purpose. His first chronometer had the (at that time) unheard-of rate, in a sea voyage of 150 days, of 1 minute, 49 seconds, and the English Parliament therefore granted him, in 1769, one-half of above-named reward. Of historical celebrity among the numerous chronometer voyages are those of the year 1826; thirty-five chronometers were taken six times from Greenwich to Heligoland, Altona and Breiten, and back to Greenwich. The mean deviation of the best chronometers of this expedition amounted to only 0.85 arc second of the distance. The time-ball was but a consequence of the chronometer, and serves for comparing local and chronometer time. Its purposes are too well known to the readers of 'THE JEWELERS' CIRCULAR' to require explanation. England was the first to establish time-balls; more than thirty years ago, and there are at present 14 of them in the largest seaports of the United Kingdom; Germany has seven, France seven, besides two other stations of a similar kind, Sweden and Norway, Austro-Hungary, Holland and Belgium, and the United States, each, have five, Denmark two, Spain and Portugal, each, one, Italy and Russia, none.



[THE CIRCULAR is not responsible for the opinions or statements of contributors, but is willing to accord space to all who desire to write on subjects of interest to the jewelry trade. All communications must be accompanied by a responsible name as a guarantee of good faith. No attention will be paid to anonymous letters. Correspondence solicited.]

"STRONG WORDS AND BITTER, BUT TRUE."

Cazenovia, May 23, 1889.

To the Editor of the Jewelers' Circular:

Time was when the watchmakers, jewelers, goldsmiths, and silver-smiths were called "Members of the Ancient and Honorable Craft." I say time was, for alas, "How are the mighty fallen!" Time was when it was hardly considered honest to sell 12 carats of gold and 12 carats of brass as solid gold; when indeed, it required a strong recommendation by a dealer of established reputation to succeed in putting upon the market as gold anything below 15 carats fine. I believe the large majority of our craft in these times are honest men and desire to sell honest, straight goods, and for this reason I am moved to put these thoughts on paper.

Hardly a month passes but we are offered goods the prices of which awakens our suspicions, and when we ask about the quality we get a shrug of the shoulders and are glibly told, "Oh, they are all right, they will not tarnish. Of course, you cannot expect to get a plump 14-k ring for that price, but no one knows the difference. You see they are not stamped all right, your neighbor sells them and you might just as well make part of the money as to let him have it all." These arguments are used and more of the same sort while the invisible "black fellow" behind you whispers in your ear, "Try them, no one will know it, and if they do find out, you can say you are very much surprised as you bought them in *good faith*." Many a young dealer has wrecked his reputation and lost his chance of ever becoming prosperous by listening to these charmers.

Really we *are* getting sadly demoralized. Watchcases looking like solid gold are advertised in the papers as "solid rolled gold," at fabulously low prices. You can take your choice now between handsome looking filled cases, not warranted to wear twenty-five minutes, and those guaranteed to last twenty five years. *Solid gold* rings are offered you, at prices which convince you they must be at least six carats fine, and I have had four carat gold spectacles offered me. What are we coming to? Must we turn our stores into "Peter Funk" shops? Shall we maintain the former integrity of our business, or shall we drop it to the level of the bargain store?

It seems to me that this time of unusual depression is a good time to devise plans for shutting off this flow of illegitimate goods through the channels of legitimate trade. I say *illegitimate* goods advisedly. You will see the point if you ever try to find their parentage.

If we can do nothing else, let us combine and agree to sell only those goods which are plainly stamped with the quality and maker's initials. Then let the people understand through liberal advertising, just the stand we propose to take, and I fancy the trade in our lines would grow better. If those who have no reputation to maintain desire to handle these doubtful goods let them do so, it will only help the legitimate trade. I know that there is a demand for plated goods in jewelry and for filled watch cases, and this demand must be met, but let us meet it honestly and with goods which we are willing to back up by our reputations and the beauty of which is more than *skin deep*.

If the 17,000 jewelers in the United States should throw their influence in the right direction, it would soon become very unpopular, to say the least, if not actually a matter of mortification, for a man or a woman to be caught wearing any article of *snide* jewelry.

I hope I have not written too strongly, and I shall be gratified if what I have written shall cause some one to suggest a way to lift the cloud of suspicion which is settled over our business.

Twenty years ago, when I began my trade, rolled plate meant the best quality of plated jewelry. Will some one please explain to me what it means now? Already some of the wide-awake manufacturers are adopting a series of marks for plated jewelry showing its quality. If we can have these goods which are plainly stamped, we can stop the flood of worthless imitation goods with which the country is being flooded by peddlers and unprincipled dealers.

We are all desirous of increasing our trade. This is the problem we must solve. If I sell a piece of jewelry which will tarnish in a few weeks, no matter how low the price, will it produce in the mind of the buyer a desire for more jewelry, or will it create a feeling of distrust and disgust for all jewelry?

Respectfully yours, JESSE W. HALL.

OLD LINE VERSUS ASSESSMENT INSURANCE.

New York, May 10, 1889.

To the Editor of the Jewelers' Circular:

No one will question the propriety of the plans of the old line insurance companies and their adaptability to the requirements of some classes in the community. We will grant them the right to exist, therefore. We do, however, question the propriety of considering every man as a machine which grows older year by year, meanwhile periodically grinding out his premiums for the company according to the tables they have provided. All he has to do is to grow old according to the mortality table provided and pay his penalty therefor and in accordance therewith, regardless of his surroundings, except so far as they may be old line life insurance companies.

One would suppose, to read the tables, that these actuaries considered man as but an aging, money-producing, unreasoning animal, which must stand up to the rack as laid down in the tables.

Such is the prominent characteristic of a book recently issued by one J. J. Habrich, an insurance agent, in the interest of old line insurance companies.

On the other hand, the assessment companies consider a man as they find him, with his hopes, his apprehensions, his desire to marry, to raise his family, and to provide for the contingency of his loss to the members of his family while they are incapable of support.

Between the ages of 25 and 45 years is when most men require such contingent provision for their young and growing families. When, after 45 or 50 years of age, the girls have married out of the family, and the boys have become self-supporting, the need of further life insurance closes for most men.

If, now, they want to continue to simply speculate on their own lives, they may continue to pay their higher rate of assessments, or resign and be replaced by their married sons, who can practice the same caretaking as was evinced by the parents.

There are thousands that think the latter plan of life insurance best adapted to the requirements of themselves, their friends and their families, and who decline to be laid out and measured by the yard stick and percentage tables of the old line companies.

In other language, they decline to second the effort of the old line companies to fit the man into the arbitrary suit of clothes they have provided for him according to their ideal of a suit, but prefer the assessment societies, which fit the suit to the man's requirements and abilities. He is buying to wear now, and so long as he pays for it is entitled to buy where he pleases.

The disingenuousness of the whole book as "a practical illustration of life insurance" is shown by the fact, as acknowledged in the prefatory remarks, that the author has selected from the assessment societies *one* of "the largest and apparently most successful, * * * and therefore may be fairly taken as their former representative" for the purpose of comparing its record with that of an average of several old line companies.

We opine that the author has somewhere read the story of the old

Roman and his sons now immortalized (the story, not the Roman and his sons), in the Fasces, the old Rome's emblem of power, and ability to break one opponent at a time.

Why not in all fairness have averaged the assessment societies against an average of an equal number of old line companies? He would then avoid the apt inference that he is writing to break one of the sticks, the said "banner representative," instead of writing a quasi candid "practical illustration of life insurance."

Furthermore, if this one "banner society" is his text for belittling and belaboring all assessment societies, may we not reasonably suppose him, by reason of his insincerity therein, to be an enemy of assessment insurance? And if an enemy, are we ready to admit the correctness of his dictum that the said unnamed society is the "banner" or representative society?

Again, with a charming naivete, the traducer of all assessment societies, after discussing the "instability of assessment societies," heads another dissertation on the before-mentioned unnamed association thus: "Rates of Assessments Must Increase With Age." This is just what the Jewelers' and Tradesmen's Company, an assessment society, has been doing ever since it was founded, and it must feel proud that it can thus meet the approval of an enemy of assessment insurance, whether it be wise to do so or not. Perhaps the Jewelers' and Tradesmen's Company may also win further approval from this illustration of life insurance for having long before fallen directly into line with his suggestion to use a certain mortality table, followed by this language: "The distinguished actuary, Shepard Homans, the author of the above table, in a treatise published May 10th, 1888, says:

"The attempts by so many co-operative or assessment companies to furnish insurance by assessments based upon the age at entry, and which rates do not increase with age, must inevitably result in disappointment and disaster. Natural laws may not be violated with impunity."

Would it modify Mr. Habrich's bitterness against all assessment societies to know that the assessment rates of the Jewelers' and Tradesmen's Company are substantially the same as those recommended by him, or does he doubt that any good thing can come out of Nazareth?

He writes thus also: "The absolute necessity for increasing the assessment rates yearly is further confirmed by an apt quotation from a letter of the eminent independent actuary, Mr. David Parks Fackler, published in the *Insurance Times* in 1883:

"If the death funds of a society are to be raised only as the deaths occur, each member should contribute for current claims just in proportion to the risk of death at his own current age."

"That any other system would be inequitable must, it seems to me, be as clear to all persons of average sense as that two and two will always make four; if any such say they cannot see it, excuse my apparent curtness but the matter will not admit of argument."

It may annoy the author of "practical illustrations of life insurance" to learn that although classed as an assessment society, and thus subject to the scourgings of the author, the Jewelers' and Tradesmen's Company is founded on just the system which he thus approvingly quotes. There are those who prefer to bend down with one eye to a knot-hole in a fence and satisfy thus their narrow physical and mental vision rather than to stand upright on their feet as God intended they should, with two eyes above the top of the fence and view the landscape in all its breadth and beauty.

If the said author's specious diatribe be intended to convert our assessment society advocate to the doctrines of the old line advocate he may feel as proud as the schoolboy who wrote an essay on "Pins": "Pins have saved thousands of lives," it said. "But how?" asked the teacher. "By folks not swallowing 'em" was the essayist's reply.

GILBERT T. WOGLOM.

San Francisco, Cal., May 13, 1889.

To the Editor of *The Jewelers' Circular*:

Having read with the greatest interest your very valuable article, "How to Test for Magnetism" in *THE CIRCULAR*, I take the liberty of asking you, as an expert, as to your manner of demagnetizing. I am not able to take the magnetism out entirely; am successful sometimes, especially in fine, complicated watches, as repeaters with very hard gongs and hammers. I do not use for demagnetizing a reversing cylinder with crank to withdraw plates of battery—a very exact working machine with watches lying inside the coil. Was for several years satisfied with its working, but since I have used your tester, find that I have not perfection, and that I have to improve.

E. HARTMANN.

[I do not know what demagnetizing machine you use; but if it works well, with the exception that it does not remove *all* the magnetism, you should employ a stronger current, until it does.—EXCELSIOR.]

BACK NUMBERS TO BUY AND SELL.

Canton, Ohio, April 18, 1889.

To the Editor of *The Jewelers' Circular*:

The numbers I want are April, 1884, and January, 1886. I have for sale March, 1880, February, June, September, November and December, 1884.

G. W. LAUGHLIN.

KIND WORDS.

Toronto, Can., March 18, 1889.

To the Editor of *The Jewelers' Circular*:

I have been a constant subscriber for some years now to *THE CIRCULAR*, and I look for it every month as an old friend. In fact could not do without it.

C. WRIGHT.

Manager American Clock & Jewelry Co.

Placerville, Cal., April 16, 1889.

To the Editor of *The Jewelers' Circular*:

Enclosed find the required amount for your valuable journal without which we could not relish our lunch. Am glad to say it comes regularly; is newsy and to the point in every particular.

F. F. BARSS & SON.



The following list of patents is compiled from the records of the United States Patent Office, and specially reported to *THE JEWELERS' CIRCULAR*.

Issue of April 30, 1889.

- 402,135—ENGRAVING AND CHASING MACHINE.** WILLIAM W. BRADLEY, Newport, Ky., assignor to John C. Dueber, same place. Filed March 14, 1888. Serial No. 282,708. (No model.) The combination, in an engraving and chasing machine, of a mandrel having a head, a screw-threaded shank and a longitudinal groove; the ornamented roll secured to the head by the screws, the head having a screw that enters the groove; the stop plate having an annular neck surrounding the mandrel; a series of notched disks mounted upon annular neck; a cap secured to the stop plate by screws traversing the disks; and a nut engaged with the screw-threaded shank of the mandrel, which latter is coupled to the driving chuck.
- 402,171—CUTTING-OFF MACHINE FOR JEWELERS' STOCK.** FRANK L. LEWIS, Providence, R. I. Filed January 10, 1889. Serial No. 295,918. (No model.) This machine consists of a series of mounted cutting-off saws, together with a series of stationary guards or clearers arranged to intercept the severed blanks, and a sliding table provided with a stop gate.
- 402,314—ART OF ENGRAVING.** WILLIAM S. EATON, Sag Harbor, N. Y., assignor to the Fahys Watch Case Company, same place. Filed December 23, 1888. Serial No. 294,846. (No model.) This process consists in first engraving upon a series of pattern plates, different fragments of the entire design to be produced, including the lines which cross each other; and subsequently transferring on any desired scale, by a tracing and engraving instrument, successively, from the plates to the article to be engraved, the different fragments of the design.
- 402,329—ELECTRIC STRIKING AND REPEATING CLOCK.** ALPHONSE M. J. JANSEN and VINCENT J. A. M. JANSEN, San Willibrordo, Curacao. Filed October 9, 1888. Serial No. 287,667. (No model.) In an electric clock there is combined an impulse wheel, pallets, an arbor carrying the said pallets, a lever provided with a contact point, a balance wheel and roller for engaging the lever, an electro-magnet and an armature lever provided with a contact point.
- 402,343—REPEATING WATCH.** CHARLES MORLET, Hoboken, N. J., assignor of one-half to Prosper Nordman, New York, N. Y. Filed September



TRADE GOSSIP.

The following named jewelers were seen in town during the past month :

A. Ilch, Albany, N. Y.; E. A. Armstrong, Detroit, Mich.; C. S. Raymond, Omaha, Neb.; W. Broadbent, Utica, N. Y.; G. L. Strceter, New Haven, Conn.; J. M. Sheaffer, Pittsburgh, Pa.; H. K. Blanchard, Providence, R. I.; L. Leiter, Jacob Hammel, Syracuse, N. Y.; E. H. Ayres, Elmira, N. Y.; M. Schwed, New Haven, Conn.; A. Read, Buffalo, N. Y.; J. Hopkins, Baltimore, Md.; M. P. Hurlbut, L. Zickel, Detroit, Mich.; L. W. Bundy, Milwaukee, Wis.; J. Seely, Ogdensburg, N. Y.; A. H. Schilling, Oswego, N. Y.; E. C. Patterson, Boston, Mass.; S. M. Van Valkenburg, Albany, N. Y.; B. Emerich, Baltimore, Md.; S. J. Owens, Lancaster, Pa.; F. J. Jacobs, Cincinnati, Ohio; E. B. McClelland, Syracuse, N. Y.; J. H. Dunn, Columbus, Ohio; F. Dutton, Boston, Mass.; C. G. Weber, Pittsburgh, Pa.; C. D. Peacock, Chicago, Ill.; J. R. Burt, Detroit, Mich.; G. Gay, Hartford, Conn.; J. K. Welden, Binghamton, N. Y.; C. P. Henn, Buffalo, N. Y.; H. Moses, Richmond, Va.; J. R. Reed, Pittsburgh, Pa.; K. Schimpff, Scranton, Pa.; G. Jackson, Philadelphia, Pa.; M. Cohn, Cobleskill, N. Y.; C. C. Terry, Hudson, N. Y.; L. S. Stowe, Springfield, Mass.; J. H. Leighton, St. Louis, Mo.; Geo. H. Richards, Boston, Mass.; E. Zahm, Lancaster, Pa.; D. Wolf, Philadelphia, Pa.; A. Rhoads, Lancaster, Pa.; J. McKee, Pittsburgh, Pa.; E. C. Tower, Troy, N. Y.; D. P. Cook, Hartford, Conn.; G. W. Clous, Reading, Pa.; A. Carleton, Boston, Mass.; L. A. Graff, Syracuse, N. Y.; C. M. Veslay, Troy, N. Y.; E. G. Hine, Washington, D. C.; O. W. Wallis, Chicago, Ill.; G. Weil, Danville, Pa.; F. Hess, Harrisburg, Pa.; H. E. Kenny, Detroit, Mich.; E. Walter, Baltimore, Md.; J. W. Wright, Toronto, Can.; M. Rosenberg, Philadelphia, Pa.; A. L. Saltzstein, Jr., Washington, D. C.; Max Meyer, Omaha, Neb.; C. G. Wilson, Reading, Pa.; L. Lake, Baltimore, Md.; C. W. Smith, Chicago, Ill.; W. J. Reid, London, Can.

—The international medal presented for competition by G. L. M. Sacks, and won by a member of the Blackheath Harriers' Club, is a very fine specimen of the goldsmith's art. It weighs $3\frac{3}{4}$ ounces of 14 and 16 karat gold, and was designed and executed by Robert Stoll, 19 John street, New York, on whom it reflects the highest credit.

—The management of the Otay (Cal.) Watch Factory now in course of construction, has adopted a co-operative plan in its method of selecting the future employees of its works, that will have the two-fold beneficial effect of building up the town of Otay to a respectable size, and placing the new industry upon a firm foundation. Every man who is to work at the factory must become a bona-fide settler, acquire property and build a cottage.

—George H. Elson, of 27 Beacon street, and George A. Richards, formerly with the late firm of Crosby, Morse & Foos, and Palmer, Bachelder & Co., have formed a co-partnership under the firm name of Elson & Richards, and have commenced business at 9 Park street and 27 Beacon street, Boston, Mass. They will carry a full line of watches, clocks, diamonds, jewelry, silverware, etc., making a specialty of fine goods suitable for wedding gifts.

—A. J. Logan, manufacturer of watchmakers' tools, hair-springs, spring wire, and small springs of every description, whose works are at Waltham, Mass., has just placed upon the market a .001 and .01 of an inch jaw and upright gauge, and jaw and depth gauge. Mr. Logan, last month, delivered 2,000 screw drivers to the American Waltham Watch factory, the largest order for screw drivers he has ever filled, and one of the largest orders for such articles that the American Watch Co. has ever given.

—C. Cottier & Son, one of the oldest and most reliable houses in the business of importing precious stones and gems, have now in stock and ready for the inspection of manufacturing jewelers and dealers, one of the best selected lines of the above goods to be found in the city. Their stock of rubies, emeralds, cats-eyes, pearls, alexandrites and fancy gems when examined will be found well worthy of special attention. J. C. Cottier left for Europe on the 25th of May, and is at present engaged in purchasing goods of most desirable qualities for this season's trade.

—It is said that the Keystone Standard Watch Co. proposes shortly to start a case factory.

—On May 1, S. B. Champlin & Son moved into their new building, No. 74 Chestnut street, corner Clifford street, Providence, R. I. where they have the best of facilities for the manufacture of rings, etc.

—Robert Stahl, of L. Sauter & Co., 1 Maiden Lane, who has been in Europe some time over a month, is expected home in a week or so. Mr. Stahl went to Europe to recuperate his health, traveling for the most part in the northern part of Germany.

—The superintendent of the Great Northern Railway, King's Cross, London, Eng., has ordered from Robbins & Appleton, London, 20 Waltham non-magnetic watches for use by the engineers and guards of the famous Scotch express train on that road known as the Flying Scotchman, whose time between London and Edinburgh is 60 miles an hour, inclusive of stops. This little item may give an idea of the high opinion in which these watches are held by one of the classes of people for whose use they are intended.

The American Watch Tool Co., of Waltham, Mass., is at present doing a brisk business. It has just completed a model for a very superior typewriter, which the Company expects to manufacture in large quantities. The new "Webster Whitcomb" lathe is creating a lively demand. It is the highest achievement of Mr. Webster's long career at lathe manufacturing. It is said to contain more excellent qualities even than the famous "Whitcomb," which needs no praise, as it has said in praise of itself during its use in years past more than it is in the power of words to express. Many large orders are being placed with the company by the various watch companies, so that the works present a scene of much activity.

—On another page of this issue are illustrated several views of the patented clamp scarf holder, manufactured by John A. Riley, 860 Broadway, New York. Mr. Riley has been preparing for some months past a large and varied assortment of this article, with which he is now ready to supply the trade. These holders combine beauty with practical utility, for besides being made in sterling silver and 14-k gold, they are beautifully chased, or gem-ornamented. The clamping device is simple, strong and reliable. As during the warm months this year the wearing of tennis shirts will prevail among gentlemen to a larger extent than in any previous year, a good demand can be anticipated for this appropriate article.

—The New York Standard Watch Co. is now almost settled in its new quarters, 13 John street, (store, Corbin Building, Broadway and John st.) During May a lively business was done, notwithstanding the unfinished condition of the store. The Company has been accepted as a co-operating manufacturer and it is its intention to market its entire product through the members of the National Association of Jobbers in American Watches, so retailers can now order from their jobber and have movements forwarded with other purchases. The numerous testimonials received from dealers throughout the country bear evidence to the many good qualities of the Company's new 7-jewel movement. The retail jeweler, to get a comprehensive opinion of the article should send for sample or for a pamphlet of testimonials.

—Bowman & Musser, Lancaster, Pa., with their customary enterprise, have issued a net price list of their repairing department, which from its completeness and convenience should be in the hands of every dealer. Prices are quoted for the repairing of watches, cases, jewelry (including stone cutting) and spectacles; fitting Abbott's and Long's stem winding attachments to the various makes of watches; bangles, (their own manufacture); engraving, piercing, etc.; stone fitting, cutting and incrustation and electro-plating. Two sets of prices are given in the watch repairing portion of the list; one, when the watch is sent complete for repair, the other when only the parts to be repaired or made are sent. By this arrangement, in some instances money can be saved by sending the work "stripped." Numerous valuable instructions and hints as to mailing and forwarding jobs are given throughout the book.

—Jules Racine, of Julien Gallet & Co., 1 Maiden Lane, sailed to Europe on May 18 by the steamer *La Normandie*.

—J. G. Batte, of Belton, Tex., has disposed of his business to Rugely & Dorenfield, who continue the business. Mr. Batte contemplates locating in some other town.

—C. G. Alford, of C. G. Alford & Co., 200 Broadway, left the city on May 6 on his annual vacation, extending over two months, in the Adirondack Mountains, New York State.

—Jewelers who contemplate visiting the International Exhibition at Paris, are respectfully invited to make their headquarters in the sumptuous offices of E. E. Kipling, at No. 1 Rue Richer.

—During the past month F. M. Finch, St. Paul, Minn., moved from 193 3d street into his new and elegantly fitted up store at No. 155 on the same street. Mr. Finch announced his removal to the public in a two-column advertisement in the Minneapolis *Pioneer Press*.

—The co-partnership that existed between John R. Greason and C. F. Pierce, under the firm name of John R. Greason & Co., was dissolved on May 4 by mutual consent. The business, which is that of manufacturing fine gold jewelry, is continued at 182 Broadway by Mr. Greason.

—On May 1 the partnership that existed between John J. Ferguson and C. A. Schnack, of Alexandria, La., was dissolved by mutual consent. Both parties continue in business on their own separate account, C. A. Schnack buying out the building and stock of the firm and settling all outstanding debts, while John J. Ferguson opened his new store on May 15.

—The productions of the Nicholson File Co., of Providence, R. I., are too widely known and their remarkably good points appreciated to need description or comment here, as the testimony of all that have used them is that they sustain the claim of the makers that they are "unrivalled in beauty of shapes" and "unexcelled in quality." We would recommend any of our readers who have not given them a trial (they are few) to do so.

—Of the many novelties offered to the trade by Hancock, Becker & Co., 40 Clifford street, Providence, R. I., is a patent setting illustrated on another page, which, while heavy enough for diamonds, is so perforated between the points that the rays of light penetrate the bottom of the stone, making a very flashy and graceful setting. They have completed a handsome line of seal and stone rings which, being entirely new, will pay jobbers to inspect before purchasing.

—Increasing business has necessitated several changes in the office arrangements of the Manhattan Watch Co. Part of the office force has been transferred to the factory, leaving the company's double offices at 234 Broadway to be entirely devoted to the selling department. Extra desks and accommodations for visiting friends in the trade have been installed, and the company extends cordial invitation to out-of-town visitors to make themselves at home in its offices during their stay in the city.

—The Trenton Watch Co. has lately made arrangements with several leading jobbing house to carry large stocks of Trenton watches, so that the retail trade will experience as little inconvenience as possible in procuring them. Since opening its new offices at 177 Broadway the company's business has been rapidly increasing, and the improved watch is meeting with universal favor. The energy and push displayed by the new management in bringing about such a state of things entitles it to all commendation.

—We learn that J. M. Cutter, general manager of the Elgin National Watch Co., and F. M. Avery, son of the president of the same company, who left for Australia a month or so ago, have safely arrived in that continent after a pleasant trip. The object of this tour, it is said, is partly for pleasure and partly for the obtaining of information upon any points affecting the interest of the watch trade. At the Melbourne Exhibition just closed, the Elgin Company secured two gold medals for excellence of manufacture.

—The R. Wallace & Sons Mfg. Co., of Wallingford, Conn., manufacturers of solid silverware, plated ware and fine cutlery, has established a salesroom at 104 State st., Chicago, under the management of O. F. Bridges. A complete line of its goods will be carried, adding frequently the latest productions in silver and other metals, so that at all times the stock will be fresh and up to the most recent and artistic efforts in silver and plated wares. The company feels confident that it possesses the ability to please the most fastidious and exacting trade, as well as to suit the more moderate desires and tastes of those requiring goods of less intrinsic value.

W. F. A. Woodcock, who is becoming every day more and more known as a proficient instructor of horology, has moved his watchmakers' school at Winona, Minn., into a fine brick building at 179 E. 4th street, in one of the finest parts of the same city. The seating capacity of the new building is very large, allowing each pupil a commodious space at the bench. An excellent light is obtained from fourteen large windows in three sides of the building. A new pupil from Canada has just joined the school, and another is expected to arrive shortly. Mr. Woodcock will shortly send out three graduates whose training fits them for the bench in perhaps any jewelry establishment.

—The Seth Thomas Clock Company in the last week of April contracted for a tower clock for the court house of Donaldsonville, La., to replace one which was also of the company's make and which had been destroyed by fire. The company recently installed a tower clock in the office of Holmes, Booth & Haydens, Waterbury, Conn., and also one in the court house of Fredonia, Kan., and has secured an order for a clock to be placed in a church at Los Angeles, Cal., which an English lady is having erected. This latter, the Seth Thomas Co. considers quite a victory, as the lady began corresponding while in England, and compared descriptions and prices with those of English makers.

—In connection with the introduction of a new pattern in 1847—Rogers Bros. spoons, forks, etc., the Meriden Britannia Co., of Meriden, Conn., has issued an exceedingly artistic pamphlet, giving illustrations and prices of the new pattern. The artistic work is from the hands of the company's own designers. The title of the little book is of especial beauty, displaying in a most exquisite style a combination of scroll and leaf work which blends harmoniously with the practical objects on which the book treats. Four or five selected pieces printed in silver upon a black background form the first illustrated page; this is followed by others printed both with and without colors and including several representations of new designs other than the "Siren." The latter, however, hold the place of honor, and worthily so as may be inferred by examining an illustration of the design upon another page of this issue. The "Siren" will undoubtedly win the favor of the trade, not only as a new thing, but as one of the richest and most beautiful designs in the market.

—The pioneer house in the jewelry trade to break loose from the ties binding them to the public corporations, in respect to the furnishing of electric light, is S. F. Myers & Co., New York, who, employing considerable light in their several spacious stores, have invested, at a large expense, in an electric light plant, and installed it in one of their basements. The dynamo of the plant, made by the Continental Dynamo Co., is connected with a modern Ball high speed engine of 100 horse adjusting power; connected with the plant are their 250 incandescent lights, distributed throughout the establishment. The firm has also attached the power to their numerous ventilators, air fans, and other devices for atmospheric purification. S. F. Myers & Co. appear to be in favor of good light, pure air, etc., and their large force of employees are to be envied, especially as the sultry days are not far off. This is to our knowledge the only wholesale jewelry house in this country that possesses its own electric plant, and that one sufficiently powerful to illuminate a small city; but the movement is only in line with the spirit of enterprise and consideration that actuates this firm.

—Charles Jacques, 2 Maiden lane, received during the latter part of the month a large and elegant line of English mantel and hall chiming clocks.

—The Seth Thomas Clock Co. will have a fine nickel watch ready for market by July 1st. It has a breguet hairspring and 17 high colored ruby jewels in gold settings. This watch is to be named the "Henry Molineux."

—The Spencer Optical Co. state that the aluminum spectacles and eye-glasses are meeting with flattering success. They anticipate that these frames, owing to their lightness, will supersede all others as a setting for the finest lenses.

—Odenheimer & Zimmern, 69 Nassau street, New York, are actively preparing several new patterns in their widely known initial rings, lockets, and sleeve buttons, with which they expect to surprise the trade about the middle of July.

—The Towle Manufacturing Co., whose factory is at Newburyport, Mass., has just completed the enlarging and refitting of their salesroom at 149 and 151 State street, Chicago. The new improvements make the salesroom one of the most attractive in the West.

—Simon Stern, of Stern & Stern, 13 Maiden lane, is now thoroughly recovered from his recent illness, and his genial face is again seen on Maiden lane. The firm is preparing its fall stock, which, it is said, will contain one of the best lines of watches and diamond jewelry in the country.

—The new Corbin building not being finished by May 1, as agreed between its agent and the prospective tenants, Wm. H. Ball & Co., who were to occupy room 38 of the building, after allowing reasonable time to the builders to get their quarters into condition, have decided to remain at their present location, 15 John street, enlarging and thoroughly refitting and remodelling their offices, introducing electric lights, etc.

—Hipp. Didisheim, 83 Nassau street, New York, has just received from the factory at St. Imier, Switzerland, large invoices of chate-laines in gold, silver, and nickel, beautifully engraved with the latest designs. The "Nassau" watch, introduced less than two years ago, but which has since become well known, and is increasing in popularity daily, is now being made to fit 4 size American cases in addition to the former 6, 16 and 18 sizes.

—The demand for graduation medals, class rings, competition badges and trophies for out of door contests, etc., common to this season of the year, is as lively this year as in many a previous year. Out of town and city jewelers receiving orders for such articles would do well to have them executed by E. R. Stockwell, 19 John street, New York, whose facilities are perfect for the performance of such work with promptness and excellence.

—Work on the erection of the wing to Kremenz & Co's factory in Newark, N. J., is rapidly progressing, the walls as far as the second floor being up. This addition fronts about forty feet on Chestnut street, and runs fifty feet to the rear, thus affording a goodly additional manufacturing space, one that has been needed for some time. Kremenz & Co. have added some new conceits to their line of enamel goods, in brooches, scarf and lace pins, etc. This line, though but one of a number of productions of the firm, is for beauty and richness of design, and excellence of execution, the equal perhaps of any that has come under our notice.

—Koch & Dreyfus are putting their commodious new office at No. 22 John street rapidly into shape. They have refitted and repapered it throughout, so that it is now one of the most cheerful and convenient offices in the jewelry district. Their spring sales up to date are considerably ahead of last year's, and they have abundant reason to feel satisfied with the change. Mr. Leon Dreyfus returned to New Orleans on the 28th to bring his family on to New York, the details of closing out the remainder of the stock at New Orleans being left in the hands of the senior partner, Mr. Nathan Koch. It is their intention to quit the New Orleans store as soon after the 1st of June as possible.

—Postal Dictionary, published by the New York *Evening Post*, is a little book that, placed on the desk of a business office, would be appreciated as a convenience and guide in mailing matters. It is an alphabetical handbook of postal rates, laws and regulations, and miscellaneous information upon every postal subject which concerns merchants, professional men, occasional correspondents, and all who use the mail. The subjects, numbering 150, are arranged in dictionary form, and are discussed thoroughly, though tersely and simply. The book is compiled from official sources by Edward St. John, publisher of the *Evening Post*, a man of extensive experience in the use of the mails. The book can be obtained direct or from any bookseller at the low cost of 15 cents.

—We call the attention of the trade to the advertisement of George W. Shiebler, which will be found on page 35. A series of twelve new and artistic designs in tea spoons, forming a bouquet of favorite flowers, as it were, each one of the twelve being a separate design. The series may be ordered as a whole, or any separate number of the series can be furnished in quantities. The spoons are in sterling silver, $\frac{9}{10}\frac{2}{10}\frac{5}{10}$ fine, as are all the goods manufactured by this house.

—The Seth Thomas Clock Co. is still receiving orders for tower clocks. Contracts have recently been made to furnish striking clocks for the Le Moyne Normal Institute, Memphis, Tenn.; the City Hall at Meridian, Miss.; and the City Hall at Crestline, Ohio. Reuben Tower, of Waterville, N. Y., who recently ordered from the company a small quarter striking clock, has changed his order to a large quarter strike, and has also purchased a chime of nine bells from the C. H. Meneely Bell Co. The clock will strike the Westminster chime on a selection of four of these bells. The Western Union Telegraph Company continues to increase its orders for synchronized clocks from the Self-Winding Clock Company, and the Seth Thomas Company, which is under contract to furnish these self winders, is very busy in getting them out.

—In consequence of its rapidly growing business, caused by the demand for the artistic line of silver deposit goods which it has been supplying to the trade recently, the Alvin M'g Co., of Newark, N. J., has secured and fitted up a commodious office at No. 10 East 14th St. (N. Y.), where it shall keep on hand a fine and complete assortment of its well known specialties. Although comparatively a new house, it has made many friends in the trade, and built up an extensive business, through its fair and upright methods of dealing with its customers. New and handsome designs are being daily added to its already large stock of specialties made by the deposition of silver, and its various forms of ornamentation. One of the newest designs shown is that of a cup and saucer of Doulton ware upon which is deposited a beautiful design consisting of a tracery of flowers and branches in pure silver, forming a most effective contrast with the color of the porcelain underneath. The company offers to send to responsible parties any of its goods on memorandum for selection, or will send photographs of specimens of its work.

—One of the most extensive newspaper expeditions ever projected in this country is that which the Scripps' League of western newspapers will send out during the coming July. As Congress took no steps towards sending American workmen to the Paris exposition with a view to examining the advance of mechanical arts, this wealthy newspaper syndicate has stepped into the breach and undertaken the work which congress overlooked. They propose to spend anywhere up to \$25,000 in paying all the expenses of 50 American workmen chosen from St. Louis, Cincinnati, New York, Boston, Detroit, Cleveland, Chicago and other manufacturing points. The details of choosing the men who are to accompany the expedition are now being arranged. All trades will be represented, including ironworkers, carworkers, shipbuilders, carpenters, molders, printers, jewelers, etc. Previous newspaper expeditions have gone to the North Pole and to the heart of Africa, but it is probable that no expedition has yet gone out which will afford more lasting benefit to a great class of people than this one. Jewelers' organizations are invited to correspond with the Manager, Paris Expedition, Scripps' League, Detroit, Mich., concerning the selection of men.

—During a two-days' absence of L. F. Cornwell, Salida, Col., at Monarch, same State, his watchmaker, Henry F. Strauss, whom he had left in charge of the store, absconded with his whole stock of gold watches, ladies' and gentlemen's, numbering 20, 80 ladies' set rings, 50 gents' large set and diamond initial rings, 75 plain gold and engraved rings, and various other articles, valued together between \$2000 and \$2500. Mr. Cornwell followed the refugee by telegraph, and he was arrested on the Rock Island R. R., and turned over to the sheriff at Norton, Kans. By mistake Mr. Cornwell was telegraphed to Pueblo, Col. It was three days before the telegram reached his hands, during which time the prisoner was released, though he had on his person 15 watches at the time of his arrest. He has since disappeared. Strauss is about 28 years of age, 5 feet 5 inches in height, low set, wears No. 7 hat, has black curly hair, heavy moustache, dark complexion, black eyes. He claimed to be a Frenchman, and speaks French, English, and German. He claims to have worked for John L. Russell & Co., of Liverpool, England. It is certain that he was once employed by B. Gegtret, 21 Catherine street, New York, where he went under the name of Henry Brown. One hundred dollars reward is offered by Mr. Cornwell for Strauss's arrest and for the recovery of any portion of the goods. The stock has been somewhat replaced, and Mr. Cornwell continues as heretofore.

—E. Holbrook, of the Gorham Manufacturing Co., left for his usual summer trip to Europe on May 22, by the steamer *Celtic*

—Sexton Bros. & Washburn, of 41 Maiden Lane, have been admitted as members of the New York Jewelers' Board of Trade.

—The Cheshire Watch Company's new nickel watch will be placed upon the market in a few days. The increased demand for their 18 size movements retarded the work on this watch, making it two months late, but its quality will fully compensate for all delays.

—Charles Glatz, manufacturer of watch cases and jobber of American movements, on June 1 moved into room 37 on the sixth floor of the Corbin Building, Broadway and John street.

—Pinnell, May & Co., manufacturers of watch cases, of Newark, N. J., have just placed upon the market a new 8 karat acid proof watch case, which looks fully as well as a 14 karat case.

—At the Centennial Industrial Exhibition just closed at Melbourne, Australia, the Waterbury watch received honorable mention for cheapness combined with fitness for the purpose intended.

—The United States Watch Co., Waltham, Mass., will have its 6 size movement ready for delivery in September next. It is said to be one of the finest American ladies' watches made.

—The largest shipment of scrap metal, including silver, nickel, brass and copper, ever made from the factory of the American Waltham Watch Co., at Waltham, Mass., to the Waterbury (Conn.) smelters, was that of the first week of May. It weighed 12½ tons.

—Jas. Hamblet, manager of the time service of the Western Union Telegraph Co., has been appointed by that company to introduce the self-winding clock which it has contracted to put out on rental for the Self-Winding Clock Co. The Western Union Co. is ready to put them up wherever its wires run.

—Blancard & Co., 36 John street, New York, manufacturers of diamond settings, galleries and hollow balls for the trade, will be glad to send their illustrated catalogue to jewelry manufacturers who will send their addresses. No matter how dull and quiet the jewelry trade may be, this firm is always busy.

—Jacot & Son's new store at 298 Broadway, New York, is very centrally located, being on the second block north of the City Hall. The firm's stock of musical instruments surpasses anything that has ever been seen on this side of the Atlantic, and jewelers from out of town should not fail to call and examine it.

—L. Tannenbaum & Co., 65 Nassau street, New York, dissolved on May 18, Adolph Tannenbaum and Alexander Samuels retiring. Business will be continued under the same style by the senior member, L. Tannenbaum. He leaves for Europe June 5 to buy goods and will carry as large and fine a stock as ever.

—Max H. Kling, formerly of Elbe & Kling, 42 Maiden Lane, but who is now in business by himself, has secured an office in the Corbin Building. The office, which is numbered 53, is on the eighth floor. L. Goldsmith, who till a few weeks ago with J. D. Casperfield composed the firm of Goldsmith & Co., at 909 Broadway, has also secured offices in the same building.

—The unique novelty which in different sizes is at once a salt, pepper or sugar sifter, or bon-bon box, that the Pairpoint Manufacturing Co., 20 Maiden lane, recently placed upon the market, has had an unusual success, and is still in active demand. Gotten out at first as an Easter gift, it has the form of the conventional egg, the base being flat to allow it to stand, and the sifting cap being at the tapering end. The cap is in silver plate, while the body of the article is of exquisitely shaded colored porcelain, decorated with hand-painted floral designs. The novelty is made in two sizes, the smaller being applicable as a salt or pepper sifter, and the larger as a sugar sifter; in both sizes, with the cap unperforated, it makes a handsome bon-bon box.

—Wm. F. Nye's export trade in his famous watch and clock oils is constantly on the increase. In the European countries a general protest is being made from the watchmakers against the oils in use, other than those from America. The foreign oils, prepared more or less from the olive or joints of animals, are proving a failure, owing to their liability to evaporate and corrode or gum upon the watch. American importers of French and German timers, are beginning to insist upon the use by the foreign manufacturers of oils made from the jaws of fish, and experience has taught them that there is no oil so perfectly adapted for lubricating watches, clocks and chronometers as the "jaw" and "melon" oil of the blackfish and porpoise, made by Wm. F. Nye, of New Bedford, Mass.

—The Manhattan Watch Co., 234 Broadway, New York, have just placed upon the market a line of their well-known watches, fitted in gold filled cases that are guaranteed for ten years. The cases are manufactured expressly for the company by one of the best case-makers in the trade, and are fitted to movements that embrace several improvements. The company claims these gold filled case watches to be the cheapest of their class in the market.

—The Columbus Watch Co., 41 Maiden Lane, New York, have discontinued their Nos. 27 and 21 open face lever set watches in addition to Nos. 34 and 22, and now have a limited number to dispose of. These watches can now be furnished with Roman or Arabic dials as desired, and every movement is fully guaranteed. The object of these discontinuances is to allow facilities for the manufacture of their new pendant set watches.

—J. B. Bowden & Co.'s new office in the Corbin Building promises to be, when completed, one of the handsomest in the jewelry district. All the appointments and fixtures are new and attractive. Two new Herring Champion burglar proof safes of six tons each have been installed on one side of the room, and are framed in natural cherry wood. The furniture, railings, partitions, etc., are in the same material which matches the trim of the building, producing thereby a very bright effect. A point of noticeable beauty in connection with the office, is an annealed copper railing on the partition that divides the book-keeping department from the main office. The quaintness of its color contrasts beautifully with the color of the wood work. The office is fully twice as commodious as the old one.

—Wm. C. Edge & Sons, 15 John st., New York, have prepared a large assortment of necklaces and bracelets, in the material on which W. C. Edge recently was granted patent letters. The goods are made in a variety of handsome patterns, and this fact combined with the commendable principle which is the essence of the patented material, warrants us in anticipating for these articles a goodly amount of success. This material consists of numerous small elongated links composing a chain arranged in spiral order, each link interlocking at each end with the ends of two other links; by this arrangement, the chain is elastic and self contracting. Illustrations of finished articles are given in another portion of this issue. The firm continues to make their well-known woven goods, and have a new line of chain ornaments and charms.

—On the 8th of May a decision was given in the United States Circuit Court in the celebrated Dueber-Fahys-Dalzell case, which has been in litigation for the past three years, in favor of the Dueber Company. Judge Wallace, after reviewing all the details of the testimony, while admitting the difficulty of a decision where the evidence was so equally balanced on both sides, was inclined to regard the evidence of the plaintiff as preponderating, and ordered a decree in his favor. The issues upon which the decision is based were two—whether there was an agreement between the Dueber Co. and Mr. Dalzell for the sale of the patents by the latter to the company, and if so whether the Fahys Watch Case Co. had knowledge of it. The patents are on dies for making the cores of filled cases. The Fahys Company declares its intention to appeal to the end.

—On another page of this issue will be found the obverse and reverse views of the official Washington Centennial medal, which the Gorham Mfg. Co. is manufacturing under the authorization of the Centennial Committee, and under the supervision of the Committee on Art and Exhibition. The medal, which is cast from the design by Saint Gaudens, modelled by Phillip Martiny, is made in silver and bronze, and is a beautiful souvenir of the great national centennial. The printed souvenir is also in the company's charge. It is a pamphlet of eight pages, on the front of which is displayed the obverse side of the medal and the back the reverse. The inside pages contain several beautiful photogravures by eminent artists. The company is also manufacturing and are displaying a very handsome medal commemorative of both the Washington Centennial just past, and the Paris Exposition now agitating Paris. The medal is intended for the Paris Exposition, though it is suggestive of both centennials. It is approximately the size of the American silver dollar, being 1¾ inches in diameter. On the obverse side, in the middle, is a drooping winged female figure in relief, holding aloft laurel, olive and palm branches and leaves, and suspended from which on one side is the face of Washington, and on the other the face of Mirabeau, both in medallion. The faces are in relief and are finely executed, the likenesses being almost perfect. The figures 1776, 1789 and 1889 are also on this side. On the reverse side are the phrases, "Centennial of the Republic," "Progress," "Labor," and the salutation, in English and French, "To all men, our brethren," "A tous les hommes, nos freres." The medal is made in silver and bronze.

AMERICANS SHOULD WEAR AMERICAN WATCHES.

THE
WATERBURY WATCH CO.

CAN SUPPLY RELIABLE TIMEKEEPERS AT PRICES WITHIN THE REACH
OF EVERY INDUSTRIOUS PERSON.

THE LADIES' WATERBURY WATCHES, "SERIES L."

THE NEW SHORT-WIND, STEM-SET, "SERIES J."

THE LONG-WIND, "SERIES E," WATERBURY.

These watches are SOLD ONLY through the regular retail watch dealers and cannot be bought otherwise.

Do not let your stock run low.

Do not wait for our traveling salesmen, but send your orders by mail at once.

THE WATERBURY WATCH CO.,

GEORGE MERRITT, AGENT.

92 & 94 LIBERTY ST., NEW YORK.

—Chester Billings and J. C. Mount, of Randel, Baremore & Billings, returned from Europe on the 26th by the *Etruria*.

—The Standard Watchman's Clock, of which O. E. Hausburg, 71 Nassau street, New York, is sole agent, is gaining more and more in favor monthly, and is being utilized largely by insurance companies, hotels, public buildings, all classes of factories, and, in fact, is being adopted in every place that requires and by every individual that desires special protection. It is too well-known to bear description. The success of the clock has been achieved through the simplicity and strength of its construction. It is in all cases warranted perfect and satisfactory, and will be delivered to any reliable house on a trial of thirty days.

—The Brown & Sharpe Manufacturing Co., in conjunction with Darling, Brown, & Sharpe, both of Providence, R. I., have issued a complete catalogue and price-list of machinery, castings, small tools and instruments to the number of over three hundred, many of which are used in jewelry and watch manufacturing. The articles of this company are made with the intention that they shall be the best of their respective classes, and careful attention is given to insure workmanship of the best quality. All machinery is subjected to inspection in detail, and to actual operation if necessary, before being packed. The companies pay attention to the careful grinding of jewelers' rolls and flattening dies, and annealing and case hardening. They are prepared to manufacture any variety of special machines, parts of machines, and a large range of articles in the line of machine work.

—The Sterling Company have enlarged their office at 176 Broadway, New York, have totally refitted it, and have partitioned off a private apartment for the better showing of goods to visitors. These improvements render the office one of the most attractive in the trade, and the accommodations that can be afforded out-of-town customers are of the best. George Parks, the company's well-known representative and manager of the office, returned on the 25th from his regular western trip, and reported that the volume of his sales was far ahead of that of any previous spring trip, which assertion, when we consider the prevailing low state of trade, bears evidence of the excellent nature of the goods he handled. At the works in Providence every line of goods, including those of leather with silver mountings, is being largely increased, and new, original and tasteful designs are superseding the older and less attractive. Almost every variety of silverware, with the exception of that adapted for the table, is manufactured by the company, and the vacancies are being rapidly filled in. For the fall trade is promised a more extensive assortment of new articles than ever before.

—The Treasury Department has issued its report of the state of trade for the month of March, 1889, and from it we glean the following data of interest to jewelers: Exports of clocks, 1889, \$118,115; 1888, \$91,862; watches and materials, 1889, \$12,436; 1888, \$18,994; jewelry, 1889, \$280,148; 1888, \$26,107; plated ware, 1889, \$64,975; 1888, \$36,860. For the nine months ending March 31: Exports of clocks, 1889, \$827,548; 1888, \$885,219; watches and materials, 1889, \$158,863; 1888, \$238,669; jewelry, 1889, \$572,129; 1888, \$336,611; plated ware, 1889, \$436,532; 1888, \$419,913. Imports of clocks, 1889, \$20,855; 1888, \$14,474; watches and materials, 1889, \$130,622; 1888, \$141,265; jewelry, 1889, \$108,658; 1888, \$114,464; precious and imitation stones, 1889, \$1,095,993; 1888, \$748,518; rough diamonds, including glaziers' diamonds, 1889, \$42,912; 1888, \$18,499. Imports of clocks for the nine months ending March 31: 1889, \$351,530; 1888, \$315,576; watches and materials, 1889, \$1,272,576; 1888, \$1,253,870; jewelry, 1889, \$1,019,700; 1888, \$889,531; precious and imitation stones, 1889, \$7,927,314; 1888, \$7,687,163; diamonds, in the rough, including glaziers' diamonds, 1889, \$207,828; 1888, \$192,762.

—Adjoining the pretty office of the Trenton Watch Company at 177 Broadway, New York, the Ott & Brewer Co., of Trenton, N. J., have fitted up a little office that is a veritable art room. The walls are handsomely papered, a chaille curtain hangs over the window, a Brussels rug covers the floor, and three cabinets and a corner stand of antique oak, filled with numerous specimens of the company's beautiful Belleek china stand against the walls. The establishment of this office has been brought about to afford better facilities than heretofore for reaching the jewelry trade, for which the Belleek china is especially manufactured. Of late years the larger and finer class of the jewelry trade have deviated from the old rut of the goldsmith, and have become dealers of the beautiful, or *articles de vertu*, rather than as distinctive jewelers, art pottery and bric-à-brac forming a prominent portion of their stocks. But till the introduction of the Belleek ware it was a difficult matter for American potters to sell their productions to the jewelers. The Ott & Brewer Co. dispelled

this prejudice to a large extent, and now Tiffany & Co. carry a large line of the Belleek, as do numerous other high-class establishments throughout the country. The Belleek china is in imitation of the rare egg shell pottery of China, the highest esteemed porcelain of past ages. To its original pure white beauty is added the exquisite colors and decorations of the famous Royal Worcester ware. Its fabric is most delicate, in thickness being not much more than that of an egg shell and is beautifully translucent. An idea of its marvelous lightness may be gained from the fact that a dozen cups and saucers, numbering 24 articles, weigh exactly sixteen ounces. The shapes are varied, original and beautiful. The Belleek is made in vases, cups, saucers, plates, tea pots, peppers and salts, rose jars, urns, creamers and others too numerous to specify.



[FROM OUR SPECIAL CORRESPONDENT.]

PHILADELPHIA, May 20, 1889.

Business in Philadelphia is in a somewhat more flourishing condition than when I last addressed you. The salesmen on the road are sending in a goodly sprinkling of orders, enough to keep the jobber in an expectant frame of mind, and all are looking forward to the usual fall awakening. The optical branch of the business seems to be quite brisk, for Philadelphia enjoys a reputation in this specialty second to none. M. Zineman & Bro. report the largest order of the season from a house in the far West. The National Optical Co., 11th and Mifflin streets, are very busy turning out their well-known specialties, royal alloy and nickel compensating spectacles, which they market through the jobbing trade only. These goods are daily growing in favor, and the general complaint of dull trade is not heard at their factory. The optical and silver plate departments of David F. Conover & Co. are also well supplied with orders for this season of the year.

President Boynton, of the United States Jewelers' Guild, recently paid a visit to this city on the invitation of the Philadelphia Retail Jewelers' Association, and the result has been to inspire the officers with new zeal and courage. The Association announces that on Decoration Day they will have a benefit performance at the Walnut Street Theatre, when the musical comedy star, Verona Jarbeau, will appear in "Starlight." The local trade have subscribed liberally for the entertainment, and the Association expects to come out with a handsome balance in its favor.

A controversy that is attracting considerable attention among the local trade, is that which has arisen between Chas. S. Hirst, the popular agent of the Dueber Company in Philadelphia, and a London house over the ownership of a safety watch pendant, now being manufactured and sold in England, as Mr. Hirst claims, in infringement of his rights. He has taken steps to prosecute the alleged infringers, and contemplates forming a stock company to manufacture the device. Among the advantages claimed for it are that it will baffle the pickpocket.

The end of the first corporate year finds the National Watch Case Co., 717-719 Arch street, with a factory full of hands, plenty of orders ahead and a good balance to show for the year's activity. They have an improvement in cases which they are perfecting and from which they expect good results.

I. Bedichimer, 618 Chestnut street, is constantly receiving orders for fine presentation jewels and shrine badges from California, Colorado and the far West, and claims that last month excelled all previous records for large orders. He has just distributed among the trade a very unique advertisement in the shape of a foot rule and calendar combined, folded into a neat paper case.

A watchmaker's school, called the Philadelphia School of Horology, was started in this city recently at 1148 Seventh street, by Martin E. Harmstead.

A curious tale comes from Lancaster, Pa., where the Lancaster watch factory is located. A Bitner was relieved of his duties as superintendent by the Board of Directors early in the present month. To the surprise of everybody he immediately brought criminal suits

against some of the officers of the company, charging George M. Franklin, President, with perjury, and Mr. Franklin and W. Z. Sener, of Lancaster, and Dr. C. N. Shellenberger and W. J. Atkinson, of Philadelphia, with conspiracy to defraud the stockholders of the company. Mr. Bitner alleges in his complaint before the magistrate that Mr. Franklin in November, 1886, made affidavit that 10 per cent. of the capital of the company (\$50,000) was paid in, when it had not been paid. The complaint for conspiracy charges that the four persons named so managed the company's affairs that the stockholders were defrauded of money they had in the concern. All the defendants entered bail at once. The sentiment of the trade and of the community at Lancaster is with them. They state that Mr. Bitner tried to compel them to purchase \$18,000 of stock held by him, and threatened them with charges of this character if they did not buy. As a sequel to Mr. Bitner's charges, it is interesting to know that he is now accused by the Water Committee of the town of secretly tapping the water main which supplied the factory.

One of the largest and oldest established clock houses in the country is that of B. J. Cooke's Sons, 137 North Third street. It was founded by the father of the present proprietors in 1853, he succeeding the Jerome Clock Co., for whom he had carried on business in that city. The Messrs. Cooke being born in the business and having kept abreast of the times, know a thing or two about clocks and can supply anything called for in that line. Their bronze department, which is very large, is the outgrowth of the clock business, the handsome parlor and mantel clocks usually requiring top and side ornaments to make them complete. Watchmakers' regulators are a specialty. Next fall they will add to their present assortment a fine line of onyx clocks, their orders having been already placed with the importer. Our readers, when in Philadelphia, will be well repaid by a visit to their establishment. Ben. Cooke, the youngest member of the firm, is well known to the trade in all the principal towns of Pennsylvania. Their advertisement, which has almost become a trade mark, has appeared in every issue of THE CIRCULAR, for several years past.

Obituary.

WILLIAM SMITH.

An event during the past month that inspired the deepest and sincerest expressions of sorrow, near and far among the jewelry trade, was the death of William Smith, of William Smith & Co., and President of the New York Jewelers' Board of trade; a gentleman who for a quarter of a century had been closely identified with the best interests of the jewelry trade. When it was told in the jewelry district of New York, on the morning of May 3d, that Mr. Smith had died suddenly during the night, regret was expressed on every side. Many doubted the report, as Mr. Smith had only the day previous been seen among the trade, apparently enjoying good health and in his usual spirits. Inquiry substantiated the report, however.

Mr. Smith breathed his last at 1 o'clock, on Friday morning, May 3d, at his home in Brooklyn, after an illness of only two hours. At 11 o'clock he retired for the night, and almost instantly was affected with pains at the heart, which became so violent that a doctor was summoned. But he was past help, passing away quietly at 1 o'clock.

William Smith was 61 years of age as his death, and leaves a wife and nine grown children. He was born on Dec. 31, 1827, at Paisley, Scotland, of poor parents. When thirteen years of age, he came with his parents to this country, landing at Fall River, Mass., where the family took up its residence. The lad had always shown an aptitude for work, and was inspired with a keen ambition to make his mark in the world. At first, he was employed in several of the print shops that that city is known for, but his aspirations were higher, and he accordingly entered the employ of A. Brown & Co., jewelers, of Providence, R. I., in 1854. He soon mastered every detail of the trade, and became a journeyman, serving as such for nearly six years, when his business abilities won for him a partnership in the firm. The other partners were Allen Brown, and George Reynolds; the firm name being Smith, Reynolds & Brown. The energy and ability of Mr. Smith soon placed the concern upon a sound foundation. In 1865 the firm was dissolved, William Smith & Co., composed of the deceased, John Smith, a brother, and O. C. Lenz, succeeding. Prosperity favored the new concern, due in the main to William Smith, who did all the traveling. But the profits of the firm were not large owing to the numerous heavy failures throughout the country in which it was concerned. It has often been remarked how William Smith & Co., escaped magically from failures that overwhelmed other manufacturers, and the story is often told, how when a failure in the trade occurred, one of the first questions that was asked by the outsiders was, "How much is Smith in for." In 1867, it was considered necessary to open an office in New York, and one was rented at 66 Nassau street; two years later saw the office at 14 John street, where it remained 10 years; it was then removed to 25 Maiden Lane, where it remained till 1886, when it was again removed to 33 Maiden Lane, at which place it now is. In 1883, John Smith and O. C. Lenz retired from the firm, and David N. and William Smith, Jr., two sons of Mr. Smith were admitted.

When the New York Board of Trade was organized in 1885, Mr. Smith was unanimously elected treasurer, a position he filled with honor and fidelity to his trust. In February last, he was elected president and held that position till his death. As a mark of respect, the Board's room were closed on the day of his funeral. On Monday, the 6th, the Board of Trade met at its rooms in the Knapp Building adopted the following resolutions:

Whereas, Death has suddenly removed from our midst Mr. Wm. Smith, for many years our efficient Treasurer, and lately our honored President:

Resolved, That we deeply deplore the loss of one, who, by his wise counsel, sound judgment, and untiring devotion to the interests of this Association, has so materially enhanced its usefulness and strength:

Resolved, That our heartfelt sympathy is tendered to the family in this their hour of bereavement and sorrow:

Resolved, That we (The New York Jewelers' Board of Trade)



President, HENRY HAYES.....Of The Brooklyn Watch Case Co.
 First Vice-President, JAMES P. SNOWOf G. & S. Owen & Co.
 Second Vice-President, ROBERT A. JOHNSON.....Of Celluloid Enamel Co.
 Third Vice-President, JOSEPH B. BOWDENOf J. B. Bowden & Co.
 Fourth Vice-President, CHARLES G. LEWIS.....Of Randel, Baremore & Billings.
 Secretary and Treasurer, WILLIAM L. SEXTON.....Of Sexton Bros. & Washburn.

EXECUTIVE COMMITTEE.

GEO. H. HOUGHTON.....With Gorham Mfg. Co.
 WM. H. JENKS.....With Tiffany & Co.
 A. A. JEANNOT.....Of Jeannot & Shiebler.
 GEORGE R. HOWE.....Of Carter, Sloan & Co.
 WM. BARDEL.....Of Heller & Bardel.
 J. R. GREASON.....Of J. R. Greason & Co.

At the meeting of the Executive Committee of the Jewelers' League, held May 3, 1889, there were present Messrs. Howe, Bowden, Bardel, Greason, Jenks, Jeannot and Sexton.

There were three requests for change of beneficiary granted. Two applications for membership were referred for investigation and one application was rejected. The following applicants were accepted: Edward J. Bilat, Brooklyn, N. Y., proposed by A. A. Jeannot; A. T. Blank, Allentown, Pa., proposed by J. A. Massey; Cæsar Dannenfeiser, New York City, proposed by Wm. Bardel; John B. Erd, St. Paul, Minn., proposed by Emil Geist; C. H. Heineman, Philadelphia, Pa., proposed by C. J. Pequignot; Robert C. Just, Vicksburg, Miss., proposed by Wm. Voellinger.

The next meeting of the Executive Committee will be held on Friday, June 7, 1889.

attend his funeral as a body to pay the last tribute of respect to our departed friend :

Resolved, That a copy of these Resolutions be engrossed, and sent to the family, and the same be entered on the minutes of this board.

The funeral took place on the same day from his late home at 1030 Bedford ave., Brooklyn, and was largely attended. The pall bearers were William Bardel, Thomas Quayle, Henry Ginnel, Ira Goddard, S. Oppenheimer, O. W. Wallis, T. B. Bynner, and John C. Downing. Among the other jewelers present were: M. J. Lissauer, H. Z. Oppenheimer, Louis Kahn, A. Freund, H. D. Sherrill, D. Keller, C. Knapp, I. Elbe, H. May, S. Aufhauser, J. Strauss, S. F. Myers, A. Goldsmith, P. Jandorf, L. Adler, John Senior, and H. N. Brush. The interment was in Greenwood cemetery in the family plot.

CHARLES DOWNS.

One of the most prominent figures in the eastern manufacturing jewelry trade passed away at five o'clock on the morning of May 13, in the person of Charles Downs, of Providence, R. I. The immediate cause of his death was heart failure. On the evening of the 11th, he was, apparently, in good health, and attended the supper of the Young Men's Republican Club. On the following morning he complained of illness, experiencing sensations similar to those that had chronically troubled him before, and which were the outcome of a rheumatic affection which he had been afflicted with for several years, so nothing serious was feared as the result of his indisposition. The next day, however, he began to sink, and grow worse, and died at five o'clock on the Monday morning.

The deceased was born in England in 1829; and came to this country with his parents at the age of nine years. He had not been in the country long when he began to learn the jewelry business in the works of E. Ira Richards & Co., of North Attleboro, which he shortly gave up and studied dentistry. He however afterward reentered the jewelry business at North Attleboro, engaging on his own account. About 20 years ago he moved his business to Providence, and started upon a most successful business career. Nathaniel Grant and Mr. Newell were at one time partners with him.

Mr. Downs was a member of the West Side and Pomham Clubs, He belonged also to the Calvary Commandery, K. T., of Providence, and the Bristol Lodge of Masons of North Attleboro, besides several other smaller organizations. He was thus a prominent social figure, and his genial presence will be greatly missed.

Mr. Downs had been twice married, and was always considered a kind father and loving husband. Kindness of heart and geniality of spirit were his predominating qualities, and won for him the goodwill and esteem of an unusually large circle of friends, who found pleasure and honor in his friendship.

The funeral took place on Friday, the 17th at twelve o'clock from the First Universalist Church, on Washington st., and the interment was at Attleboro. The ceremonies which were under the charge of the Masons were largely attended.

HIRAM HOTCHKISS.

On May 4, in the death of Hiram Hotchkiss, the city of Buffalo lost one of its oldest and best citizens. For almost a year Mr. Hotchkiss had been suffering from heart disease, and though his death was painfully sudden, it was not unexpected.

The deceased was perhaps the oldest jeweler in Buffalo, and his name is familiar throughout the jewelry trade of the country. For about forty years he was identified with the jewelry trade of Buffalo, during the whole of which time he was looked upon as an honorable and trustworthy business man. Hiram Hotchkiss first saw the light in the village of Burlington, Conn., on April 16, 1821, and was accordingly 68 years of age at his decease. He was brought up in that place, marrying Miss Mamie Lowry, of Burlington. In 1849 he went to Buffalo, and a year later established himself in the jewelry business at Main St., below Seneca St., in the heart of the business district of that day. As the tide of business began to move northerly, Mr.

Hotchkiss went with it, doing business for three years in the Hamlin Block, the site of the present great house of Barnes, Hengerer & Co. From 1863 to his death he occupied the store at 286 Main St., in the Weed Block. About a year ago, when his heart trouble first made itself known, he arranged for the closing out of his business, April 1 being the last day that he visited his store.

Though a firm Republican in politics, Mr. Hotchkiss never held nor sought public office, but as a citizen he was ever ready to do all in his power for the best interests of the community.

He left a wife and a dearly beloved grand-daughter. The funeral was from the family home on Delaware ave., and was largely attended. The interment was at Forest Lawn.

WILLIAM D. BLACK.

The older and reminiscent members of the trade had cause for sorrow, during the past month, in the death of William D. Black, on the night of May 5th, who passed away at his home in New Milford, Conn., from Bright's disease. He was formerly a member of the old-time firm of Ball, Black & Co., of New York, the predecessors of the present well-known house of Black, Starr & Frost. Upon his retirement from the firm in 1871, he took up his residence with his family in New Milford, and became prominent in all the local enterprises of the town of his adoption, and was a leader in the establishment of a pottery business, an electric light plant, a new hotel, a new Episcopal church, which is one of the finest of its kind in the state, and a new park. He did much to make the town more progressive and beautiful. The deceased was fifty-four years of age, and leaves a wife.

CHARLES FASOLDT.

Charles Fasoldt, of Albany, N. Y., well-known to clockmakers throughout the country as an expert clockmaker and inventor died at his home, after a few weeks' suffering with Bright's disease. The deceased came from his native place, Dresden, Saxony, to America in 1848, at the age of thirty years, and settled at Rome, N. Y. His experience as a horologist shortly became known, and he constructed, the year after his arrival, for General Armstrong, an eight day watch which had two mainspring barrels. This was the beginning of a career of invention on his part, which brought him into great prominence. In 1861 he went to Albany. He then began to devote his attention to astronomical clocks and micrometer regulators. Ten years later he constructed the first town clock of Albany, being the inventor and maker himself of many of the parts. At the Centennial Exposition at Philadelphia, he received the prize medal and diploma for a large tower clock. Ten years later, he began to devote his ingenuity to a field that brought him great distinction. This was microscopic work, and ruling of lines with a diamond on glass for which purpose he made several machines. After months of tireless energy he attained the almost incredible record of 100,000 lines to the inch. For such fine work the then existing microscopes lacked the necessary delicacy of construction. Mr. Fasoldt's inventiveness produced a more suitable instrument which has been in general use since. One of his perfected plates was purchased by the United States government.

JAMES R. HARPER.

On the night of May 5, died James R. Harper, of Montreal. Of late he had been in very poor health, and for more careful treatment had gone to the city hospital where he died.

The deceased gentleman was well known by his long connection with the jewelry business, extending over a period of twenty-five years. His specialty was the manufacture of sporting medals. When the retail trade of Montreal was in its infancy, he was a partner with Joseph Street. Just before his death, he sold out his business to R. Hemsley. Mr. Harper was a member of the Montreal Hunt, and a warm supporter of all kinds of athletic sports. He was well known and esteemed for his remarkable geniality and good-feeling which prompted him to lend his assistance in any case when appealed to.

JAMES ABBE.

James Abbe, at one time president of the Hampden Watch Company, and one of its heaviest stockholders, till its removal to Canton, Ohio, died at his home at Springfield Mass., on May 11, after an illness of three months. He was 66 years of age at his decease, and leaves a wife, a son, James T. Abbe, president of the Holyoke Envelope Co., and a daughter, Mrs. Charles D. Rood, wife of the present president of the Hampden Watch Co.

TABLE OF CONTENTS.

A Move in the Right Direction.....	40	Glimpses of the Paris Exposition.....	28	Paris Gossip.....	43	The Northwest.....	83
Around Boston.....	36	Gossip of the Month.....	19	Plated Jewelry of the Future.....	44	Trade Gossip.....	87
Attleboros, The.....	36	Jewelers' and Tradesmen's Company, The.....	42	Problems in the Detached Lever Escapement.....	64	Watch and Clock Companies, The.....	93
Chicago Briefs.....	38	Kremenz & Co. vs. The Cottle Co.....	84	Providence Notes.....	35	Watch Club System, The.....	71
Communications.....	47	Lathes and Lathe Work.....	68	Quarter Staking Work.....	76	Watches and Clocks.—A Complete History of Watch and Clock Making in America	81
Electricity and Magnetism.....	52	Mechanical Ocular Defects.....	48	Recent Patents.....	55	Window Dressing.....	60
Fashions in Jewelry.....	56	New Free Watch Escapement.....	47	The Jewelers' League.....	94	Workshop Notes.....	80
Foreign Gossip.....	79	Oldest Watch in the World, The.....	75	The Jewelers' Security Alliance.....	94		
		"On Memorandum".....	23	The Quaker City.....	40		

INDEX TO ADVERTISERS.

Abry, Chas. Leo.....	58	Crouch & Fitzgerald.....	Outside back cover	Manhattan Watch Co.....	34	Seth Thomas Clock Co., Inside front covr & 3	
Aikin, Lambert & Co.....	62	Day & Clark.....	12	Mathey Bros., Mathez & Co.....	14	Sexton Bros. & Washburn.....	85
Albro, S. & Co.....	Inside back cover	Derby Silver Co.....	57	McCall & Newman.....	70	Sheafer, W. H., & Co.....	49
Alvin Mfg. Co.....	91	Didisheim, Hipp.....	49	Merritt, S. F.....	16	Shiebler, George W.....	6
American Waltham Watch Co.....	41	Edge, W. C. & Sons.....	85	Middletown Plate Co.....	13	Smith & Knapp.....	62
American Watch Tool Co.....	66	Evans, W. F. & Sons.....	73	Miller Bros. & Co.....	50	Smith, Alfred H., & Co.....	21
Ansonia Clock Co.....	1	Fidelity Watch Case Co.....	74	Montgomery & Co.....	103	Smith B. & W. B.....	outside back cover
Anti-Magnetic Shield & Watch Case Co.....	17	Fisher & Sons.....	25	Moore & Horton.....	70	Special Notices.....	97
Atkinson Bros.....	65, 70	Floyd, Pratt & Rounds.....	58	Myers, S. F. & Co.....	74	Spencer Optical Mfg Co.....	9
Arnstein Bros & Co.....	85	French, J. H.....	73	N. Y. Watch Case Spring Co.....	97	Stern & Stern.....	15
Bates & Bacon.....	26	Friedlander, R. & L.....	14	Newman, Louis, Jr.....	103	Stockwell, E. R.....	54
Bartholomew & Peckham.....	103	Froelich, H. & Co.....	6	Newport Aluminum & Steel Co.....	74	Sussfeld, Lorsch & Co.....	42
Ball, Wm. H. & Co.....	15	Gorham Mfg. Co.....	18	New York Standard Watch Co.....	58	Taintor & M Alpine.....	33
Beguelin, Teil A.....	96	Grant, J. W. & Co.....	16	Nicholson File Co.....	74	Tannenbaun, L & Co.....	42
Bedchimer, I.....	66	Greene, W. C. & Co.....	42	Nissen, Ludwig, & Co.....	34	Taylor & Bro.....	49
Birch, John S., & Co.....	96	Haldimann, E. A.....	6	Nye, Wm. F.....	104	Ternendf, F.....	103
Blackinton, R. & Co.....	46	Hamilton & Hamilton, Jr.....	33	Odenheimer & Zimmern.....	104	Thrall, Edwin A.....	50
Blackinton, W. & S.....	45	Hancock, Becker & Co.....	33	Oppenheimer Bros. & Veith.....	57	Towle Mfg Co.....	54
Blancard & Co.....	77	Haskell, H. C.....	25	Oppenheimer, Henry E. & Co.....	37, 91	Trenton Watch Co.....	92
Bookhout Bros.....	103	Hausburg, O. E.....	103	Ostby & Barton.....	46	Troemner, Henry.....	103
Bowden, J. B., & Co.....	34	Hedges, Wm. S. & Co.....	78	Owen, G. & S., & Co.....	49	Valentine & Co.....	77
Braxmar, C. G.....	103	Howard & Son.....	4	Palrpoint Mfg Co.....	15	Valuable Instruction Books.....	Inside b'k Cover
Bryant, M. B. & Co.....	62	Howard, S. P.....	Outside back cover	Peterson & Royce.....	65	Wade, D vis & Co.....	33
Buhler & Nanz.....	65	Hyde's Sons John E.....	66	Pforzheimer, Kelter & Co.....	66	Waterman & Lehmann.....	95
Bynner, T. B.....	103	Jacques, Charles.....	25	Pinnell, May & Co.....	85	Wallace, R., Sons Mfg Co.....	69
Byrd, C. L. & Co.....	37	Jeannot & Shiebler.....	61	Plainville Stock Co.....	62	Waltham Watch Tool Co.....	16
Carter, Sloan & Co.....	53	Keller, L. H. & Co.....	96	Platt, Chas. S.....	Outside back cover	Want, Edwin.....	14
Cattelle & Decker.....	65	Kendrick & Davis.....	73	Prindle & Russell.....	77	Washburn & Moen Mfg. Co.....	103
Chalmers-Spence Co.....	73	Kent & Stanley.....	6 & 69	Randel, Baremore & Billings.....	86	Watchmaker, Jeweler and Silversmith.....	96
Cheever, J. G. & Co.....	42	Ketcham & McDougall.....	16	Riley, John A.....	50, 91	Waterbury Clock Co.....	1
Chicago Horological Institute.....	91	Kirby, Mowry & Co.....	26	Riley-Osborn Mfg. Co., The.....	2	Wheeler, Hayden W. & Co.....	46
Clark, A. N.....	73	Koch & Dreyfus.....	25	Robert, J. Eugene, & Co.....	61	Whiting, F. M. & Co.....	7
Colby, C. K.....	77	Kohlbusch, Charles.....	103	Rogers & Bro.....	11	Wiggers & Froelich.....	Inside back cover
Columbus Watch Co.....	54	Kremenz & Co.....	95	Rogers, Smith & Co.....	12	Wilkinson, C. B.....	103
Conover, D. F. & Co.....	2	Lady Racine Chatelaine Watch.....	42	Russell, Chas. A. & Co.....	Inside back cover	Woglom, Gilbert T.....	70
Cooke, B. J's. Sons.....	66	Laurencot, J. B.....	102	Russell, Irving L.....	25	Wood & Hughes.....	49
Corbin, D. R.....	6	Lawson & Van Winkle.....	14	Sauter, L. & Co.....	49	Wood, Chas. F.....	77
Cross & Beguelin.....	17	Lelong, L. & Bro.....	outside back cover	Schleicher, Schumm & Co.....	70	Wood, J. R., & Son.....	103
Crossin & Tucker.....	45	Lorsch, Albert, & Co.....	Outside back cover	Scott, J. T. & Co.....	10	Zineman, M. & Bro.....	42
Cottler, C. & Son.....	103						

NOVELTIES IN PLATED JEWELRY.

The Largest Variety and Finest Line to be
found in the market.

40 MAIDEN LANE, NEW YORK.

HENRY FROEHLICH & CO.

E. A. HALDIMANN,

JOBBER IN

American Watches,

3 MAIDEN LANE,

NEW YORK.

Particular attention paid to orders from the Country.

SEAMILESS

See
Page 69.

Infringement Notice.

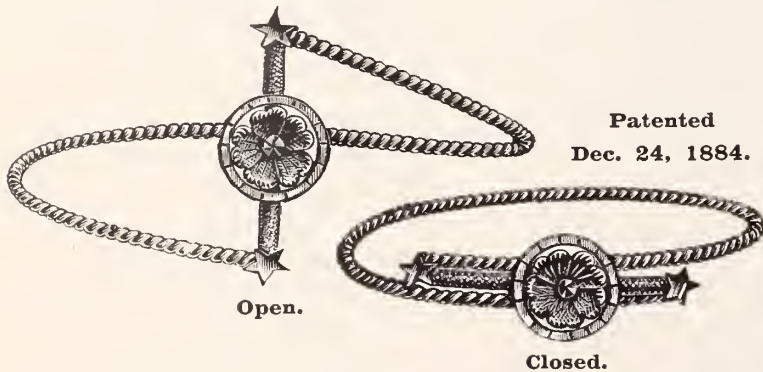

The trade is hereby notified that the bracelet above illustrated is patented and that suit will be commenced against all persons infringing on the same.

A large variety of styles of the above bracelet for sale by

D. R. CORBIN,
MANUFACTURING JEWELER

No. 10 Cortlandt Street, New York.

SCARF PINS IN GOLD AND PLATE A SPECIALTY.

TO LET.

Four fine, large floors in new Factory,
St. Marks Street and Underhill Ave.,
Brooklyn; Solid Floors; Light all
around; Power in abundance.

Fire proof Vaults built in on each
floor. Elevator, Stairs, Transmitting
Room and Plumbing in separate ex-
tension.

Apply to

GEO. W. SHIEBLER,
8 Liberty Place, New York.



THE JEWELERS' CIRCULAR

AND

HOROLOGICAL REVIEW.

OFFICIAL REPRESENTATIVE OF THE JEWELERS' LEAGUE, THE NEW YORK JEWELERS' BOARD OF TRADE, AND THE JEWELERS' SECURITY ALLIANCE.

It is also the Recognized Exponent of Trade Interests.

A MONTHLY JOURNAL DEVOTED TO THE INTERESTS OF WATCHMAKERS JEWELERS, SILVERSMITHS, ELECTRO-PLATE MANUFACTURERS, AND THOSE ENGAGED IN THE KINDRED BRANCHES OF ART INDUSTRY.

SUBSCRIPTION.—To all parts of the United States and Canada, **\$2.00 per Annum**, Postage Paid. To all Foreign Countries, **\$3.00 per Annum**, Prepaid.

All communications should be addressed to

THE JEWELERS' CIRCULAR PUBLISHING CO.,
189 BROADWAY, NEW YORK.

Advertising rates made known on application.



A full Index to Advertisements and Table of Contents will be found on Page 5 of this issue.

FRIGHTFUL as was the disaster in the Conemaugh Valley by the flood which substantially destroyed eight villages and was accompanied by loss of life, the first reports regarding the loss of life were far below the actual number lost; but later reports exaggerated this number considerably. It is now believed that between three and four thousand persons were sacrificed, and not ten to fifteen thousand, as was currently reported for a number of days. The exaggerated number was based upon an over estimate of the population resident in the valley. This had been stated at from thirty to thirty-five thousand, but more conservative estimates place it at about twenty-five thousand. The entire country entered into generous rivalry as to which should contribute the most liberally in proportion to its population and means for the relief of the sufferers by the flood. Not only were the living mourning for their dead, but property of the value of from thirty to fifty millions of dollars was destroyed. The generous outpouring of contributions amounts to probably two millions in cash, while supplies of clothing and food in great quantities were forwarded promptly, upon which no estimate of value can be placed. The state of Pennsylvania undertakes the work of clearing the valley at an expense of not less than a million

of dollars. This will give employment to a very large number of men for a considerable period, who are doing the work under supervision of State officers. One benefit to be derived from this liberal outpouring of a nation's wealth will be the distribution of large sums among needy and deserving persons, who will at once put it into circulation. The money contributed is from the surplus of individuals and represents sums that probably had been withdrawn from circulation, so that, great and terrible as this disaster was, it has so much compensation attached to it that thousands of unemployed persons have found employment for a number of weeks at good wages, while the sufferers receiving this bounty must necessarily spend it immediately for the necessaries of life and to restore their property. By the middle of June the sufferers of Johnstown had recovered from the immediate depressing effects of the disaster, and had commenced to rebuild their homes and to re-establish themselves in their usual avocations. Among the first of the merchants to resume business was an enterprising jeweler. While he probably had little demand for the articles of luxury in his stock, yet as dealers usually carry articles that are necessary in every household, the probability is that he has done a fair amount of business. One of the notable things in connection with this disaster was the alacrity with which manufacturers and general dealers offered to aid the business men of Johnstown to resume business, guaranteeing them long credits and all the goods they wanted. By this means the men who had lost everything by the flood were enabled to start again and commence anew their business careers. The people of the United States have had frequent occasion to demonstrate their generosity in times of affliction, but never before to the extent that they were required to give for the Johnstown and Seattle disasters. The loss of property at the latter place by fire was estimated at from five to seven millions of dollars, the entire business part of the place being destroyed.

* * * * *

Cut and description of the oldest known watch in the world on page 75.

* * * * *

THE case of Alfred H. Smith & Co., vs. Henry Clews, which has just been decided upon the third trial after six years litigation, is the most important in its consequences to the jewelry trade that has occurred within recent years. The confusion that has prevailed on the question of memorandum and the numerous unsatisfactory lawsuits that have arisen over it have created the impression in the outside business world and among the legal profession, that jewelers, particularly diamond merchants, conducted their business with almost criminal negligence. This decision goes far to remove that stigma. The whole case hinged on the trade meaning of the words "on approval," to the peculiar use of which on previous trials little attention had been given. So far as the law is concerned, the meaning of the words "on approval" or "on memorandum" is now

thoroughly established in the State of New York. Those words are now recognized by the Courts to mean that where goods are delivered "on memorandum," or "on approval" the person who receives them has not the legal power to sell them or part with the title to any purchaser, whether or not such purchaser acts in good faith and pays value. Such purchaser, if he pays value to the broker, or other person who has the goods in his possession, must surrender the goods to the true owner whenever called upon to do so, and resort to his vendor to recover from him the money he has paid. As lawyers express it, the doctrine of *caveat emptor* holds. That doctrine is that the purchaser, in buying chattels, does so at his peril as to the title. He must look out for himself. The effect of this, in the first place, is to confine dealings to responsible parties, which is a very desirable effect. A purchaser ought not to buy from a man who has not a bill of sale of the goods that he has to sell, or who has no evidence of his authority to dispose of them. It will not interfere in the slightest with the honest dealer or the honest broker; for he can very easily get an invoice from the owner, or produce direct authority or liberty to make the sale. It cuts up by the roots the disposition to pawnbrokers by dishonest clerks and brokers of diamonds in their possession. It prevents them also from putting up diamonds as collateral security to margins in stock speculations, in bucket shops or other places. For these blessings the jewelry trade is indebted to the pluck and persistence of Alfred H. Smith & Co., and the legal acumen of their counsel who was determined to carry the case on to victory.

* *

* *

* *

"Electricity and Magnetism," by EXCELSIOR, a most valuable series of articles for the watchmaker, is still continued. Worth a year's subscription.

* *

* *

* *

We have received the following communication which opens an interesting subject for discussion, and is published in full, with the answer :

Toronto, June 20, 1889.

To the Editor of the Jewelers' Circular:

I should like to have your opinion, or perhaps "Elsie Bee" would give her's upon this point. Which is the proper engagement ring finger and which the wedding? As a customer puts it: "Engagement and wedding ring fingers being the same, you have got to break the engagement whereas you are usually sealing it. Is it customary to do such things left-handed?"

I suppose the majority of people consider the third finger of the left hand proper for both rings; at the same time there are many who think otherwise. I would be pleased to have an answer by mail instead of waiting for the next issue of THE CIRCULAR if you can find it convenient.

O. WRIGHT, Manager,

American Clock and Jewelry Co.

[The third finger is the preferred one for both betrothal and marriage rings, although efforts have been made at various times to make the engagement ring finger the second. Two reasons are assigned for this preference of the third digit as the "ring finger." First, the belief entertained by the ancients that a delicate vein ran from the third finger of the left hand to the heart. Second, in the Roman Church the thumb and two first fingers represent the Trinity, the third being the husband's, "to whom the woman owes allegiance next to God." The left hand was chosen to show that "the woman is to be subject to the man." When the betrothal ring is removed to make place for the wedding ring, it is in token that the engagement with a *fiancé* is at an end and with a wife just begun. In a word, the marriage ceremony ends the betrothal. The custom of moving the engagement ring above the wedding ring is a significant one, for the former not only serves as a guard to the latter, but is a constant reminder of halcyon days, whether marriage proves a failure or not.—ELSIE BEE.]

THE club or installment system of disposing of watches and other articles of jewelry has taken firm root in many parts of the country. Its effect, notwithstanding the complaints of many jewelers, and the claim that it is not a legitimate mode of disposing of goods, has been vastly to augment the sale of these articles by bringing them within reach of a much larger public. Dishonest dealers or roving shysters have occasionally taken advantage of it to prosecute unlawful schemes, and many who went into it with the best possible intentions have met with large losses through lax and unbusinesslike methods. But these exceptions should not blind us to the advantages of the system if properly conducted. On another page "Taintor" outlines a plan of conducting a watch club which we are assured will prove a helpful stimulus to the watch business of every jeweler. None of the objections usually brought against watch clubs will hold against this. It is perfectly fair, does not excite unnecessary competition, and is an attractive advertisement in itself. Jewelers should examine this subject without prejudice. There is no terror in a name. If a watch club judiciously conducted will increase trade, it is certainly more profitable for a business man to give it a trial than to waste time and breath in hurling anathemas at some more independent competitor.

* *

* *

* *

THE interest in birthstones and occult science generally seems to be reviving in this country. A number of jewelers have accordingly been getting out little advertising cards giving the sentimental significance of the various precious stones and those appropriate to each month. One of our subscribers sends us one of these folded cards which he has found a useful adjunct in his business, and which we reprint for the information of our readers. The modern jeweler must be on the alert for every popular craze. He must be a cosmopolite and in a sense, a jack-of-all-trades, turning astrologer, milliner, and what not for the nonce if his trade demands it. The little verses that caught the fancy of our correspondent's customers are as follows :

JANUARY.

By her who in this month is born
No gem save GARNETS should be worn;
They will insure her constancy,
True friendship and fidelity.

JULY.

The glowing RUBY should adorn
Those who in warm July are born:
Then will they be exempt and free
From love's doubts and anxiety.

FEBRUARY.

The February-born will find
Sincerity and piece of mind,
Freedom from passion and from care,
If they the AMETHYST will wear.

AUGUST.

Wear a SARDONYX, or for thee
No congenial felicity;
The August-born without this stone
'Tis said must live unloved and alone.

MARCH.

Who in this world of ours their eyes
In March first open shall be wise;
In days of peril firm and brave,
And wear a BLOODSTONE to their grave.

SEPTEMBER.

A maiden born when autumn leaves
Are rustling in September's breeze,
A SAPPHIRE on her brow should bin—
'Twill cure diseases of the mind.

APRIL.

She who from April dates her years,
DIAMONDS should wear, lest bitter tears
For vain repentance flow; this stone
Emblem of innocence is known.

OCTOBER.

October's child is born for woe,
And life's vicissitudes must know:
But lay an OPAL on her breast,
And hope will lull those woes to rest.

MAY.

Who first beholds the light of day
In spring's sweet flowery month of May,
And wears an EMERALD all her life,
Shall be a loved and happy wife

NOVEMBER.

Who first comes to this world below
With drear November fog and snow,
Should prize the TOPAZ, amber hue—
Emblem of friends and lovers true.

JUNE.

Who comes with summer to this earth,
And owes to June her day of birth,
With ring of AGATE on her hand
Can health, wealth and long life command.

DECEMBER.

If cold December gave you birth,
The month of snow and ice and mirth,
Place on your hand a TURQUOISE blue,
Success will bless whate'er you do.

We would refer those who wish to study the intricacies of the language of precious stones and jewelry to a volume, entitled: "Gems, Talismans and Guardians; Their Sentiment and Language," published by John Wiley & Sons, 15 Astor Place, New York, Ten Alcott, author. The book contains a great deal of "long-forgotten lore" about birthdays, horoscopes, charms, besides superstitious concerning jewelry and gems, old Hebrew traditions and quaint saws and proverbs. The chapter on "Sentimental and Symbolical Jew-

ALFRED H. SMITH & CO.,

DIAMONDS,

182 Broadway, New York.

Dealers going to Europe this season are
invited to visit our London Office,

33 HOLBORN VIADUCT.

Respectfully,

ALFRED H. SMITH & CO.

elry" will be found most interesting to the general reader, as it explains the rationale of engagement and birthday rings. Take it all in all the work will be valuable as a reference book to those who have not entirely outgrown superstition and sentiment and who wish to placate the powers of destiny in naming children, giving presents, etc.

**

**

**

"Window Dressing." How our English cousins do it. Contains some good hints on this important subject. See page 60.

**

**

**

THE prevailing report in trade is to the effect that the spring and summer have been extremely dull. Why it should have been so at this season is a matter of speculation, for the indications were excellent. Possibly a change of administration had something to do with it, though this is scarcely probable. All lines of business were similarly affected and complain accordingly. The general impression seems to be that dealers have been overstocked, and in the absence of an active demand from consumers were not inclined to make additional purchases. In June came the great disasters at Johnstown, Penn., where the floods worked such terrible damage to property and such a frightful loss of life, and at Seattle, Wash. Ter., where the better part of the town was consumed by fire. Other sections of the country, notably Pennsylvania, Virginia and Maryland, were great sufferers by floods, simultaneously with the Johnstown disaster. This naturally affected all lines of trade disastrously in those sections. The old proverb says that it is always darkest just before the dawn, and applying this to trade matters it is probable that this prolonged season of dullness will be followed by a compensating activity in the fall. Such, at least, is the anticipation of those best informed in the trade. Certainly the surplus stock in the hands of the dealers should have been worked off during the summer, and as they have been very chary of buying they could not have added very much to the stock on hand. The country is fairly prosperous at present. All crops are looking well and promise abundant harvests. Manufacturing and other industrial enterprises have been busily employed, so that the prospects for the fall and winter trade are excellent. We hope these anticipations may be fully realized, and wish prosperity to one and all in the trade.

**

**

**

Call the attention of editors of your local papers to "Elsie Bee's" "Rambles Among the Jewelers," and have the items reprinted. It will increase your trade.

**

**

**

FLOATING exhibitions seem to be a success so far as Spain and Germany are concerned. A fine steamer loaded with the best specimens of all kinds of goods lately sailed from Spain for South America. The German Export Company has decided to apply the sum of \$1,000,000 (5,000,000 marks) on the building, equipment, and working of a very large steamer which is to serve as a floating exhibition. The vessel in question will be called Kaiser Wilhelm, and the principal dimensions are as follows: Length, 564 ft.; depth, 46 ft. The steamer is to have four engines, entirely independent of each other, and four propellers, and she is to be fitted in exceptionally good style. The expenses for a two years' tour are calculated at \$785,000, while the receipts for hire of room and profits on sales are expected to reach \$1,815,000, leaving the very handsome profit of more than \$1,000,000. The steamer will, according to the present arrangements, be ready to start in the spring of next year. A previous undertaking of a similar nature, the steamer Gottorp, dispatched from Hamburg, is understood to have given a satisfactory result. Not only are Spanish and German goods being shown in many different parts of the world, but the staff accompanying the steamer has ample opportunities for studying in each place the various local and special requirements, and seeing to what extent

and in what manner the different wants are being supplied, either by home or other foreign makers. How many years longer must the American people stand aside and see the foreign trade carried off by other nations by simple devices such as the above?

**

**

**

A Novel Watch Club Plan is described on page 71.

**

**

**

ENGLAND too, is experiencing a fashionable revival of jewelry and the newspapers there like the press on this side of the water, are lending a hand in the good work. We quote the following from the *Watchmaker, Jeweler and Silversmith*:

With the revival of fashionable taste for articles of "bigotry and virtue," as "Mrs. Partington" would put it, it is satisfactory to note the increased space that is daily, almost, devoted to the subject jewelry fashions; by those organs of the public press which are, or should be, authorities on what should be worn by fashion's devotees in other matters. The lead thus taken, and the publicity accorded to the productions of the jeweler's art, cannot (if the inspired ones are properly directed) but have a beneficial effect on the trade, and we welcome most cordially the signs of the times, of which the aforesaid are possibly the outcome, and which should mark an era in the history of the trade.

**

**

**

GREAT enthusiasm is being evoked by the displays of Tiffany & Co., the Gorham Co., the Meriden Britannia Co. and other American jewelry and silverware houses at the Paris Exposition. Some even go so far as to assert that these exhibits mark a new era in the jewelry and silverware industries. To the European critics it is nothing short of a revelation, nor, indeed, is it much less to many of our own countrymen who are inclined to think that no good thing can come out of Nazareth. At the Paris Exposition of 1878, it is true, Tiffany & Co. carried off the palm, but it has required a second competition to show the world the marvellous progress we have been making in these arts during the past ten years. We may justly pride ourselves on our attainments in these the crowning arts of civilization, but this should not satisfy our ambition. American jewelers and silversmiths have not reached their zenith yet. Another decade will doubtless bring still greater triumphs, and when next the nations come in competition we shall have fewer rivals than now. As another instance of the success that Americans are meeting with at foreign expositions, it is interesting to note that of the 74 American exhibitors at the recent Brussels Exposition 75 per cent. received awards of prizes.

**

**

**

"On Memorandum." These words are found to have a definite legal meaning at last. See account in this issue.

**

**

**

THE Treasury Department has published its summary of exports and imports for the month of April, 1889. From it we glean the following items of interest to the trade: Exports of clocks 1889, \$103,071; 1888, \$74,261. Watches and materials, 1889, \$14,483; 1888, \$56,004. Jewelry and manufactures of gold and silver, 1889, \$161,997; 1888, \$34,174. Plated ware, 1889, \$63,358; 1888, \$32,055. Exports for the ten months ending April 30—Clocks and parts, 1889, \$930,619; 1888, \$959,480. Watches and parts, 1889, \$173,346; 1888, \$294,673. Jewelry and manufactures of gold and silver, 1889, \$734,426; 1888, \$370,758. Plated ware, 1889, \$499,890; 1888, \$451,968. Imports of clocks 1889, \$25,248; 1888, \$25,364. Watches and materials, 1889, \$147,426; 1888, \$157,607. Jewelry and manufactures of gold and silver, 1889, \$77,946; 1888, \$114,388. Precious stones and imitations, unset, 1889, \$1,095,993; 1888, \$748,518. Rough diamonds, including glaziers' diamonds, 1889, \$8,382; 1888, \$21,860. Imports during the ten months ending April 30—Clocks, 1889, \$376,778; 1888, \$340,940. Watches and materials, 1889, \$1,420,002; 1888, \$1,411,477. Jewelry and

manufactures of gold and silver, 1889, \$1,097,646; 1888, \$1,203,919. Precious stones and imitations, unset, 1889, \$8,720,616; 1888, \$8,315,018. Diamonds, in the rough, including glaziers' diamonds, 1889, \$216,210; 1888, \$214,622.

* *

* *

* *

Read "A Form for Memorandum Bills," under Communications.

* *

* *

* *

AS a supplement to the very interesting series on the "Marfels Watch Collection," Frankfort on the Main, which has just been concluded in the CIRCULAR, we print in this issue an account of the latest addition to the collection, a watch supposed to have been made by Peter Henlein himself and said to be the oldest known watch. It may further interest our readers to learn the prices that are paid in Europe for curiosities of this kind. We can state on Mr. Marfels' own authority that he paid from \$500 to \$800 for most of the rarer pieces, while a few, like the wooden watch and the ivory one, are so rare that no market price is obtainable. The owner states, however, that he would not sell either of these for \$1,200. He now has, without doubt, one of the largest and most select collections of old watches in the world, yet he is constantly on the lookout for new acquisitions. Readers of THE CIRCULAR who possess antique watches or know of any that are for sale, should communicate with Mr. Marfels, at Frankfort. In conclusion we wish to extend our thanks to Mr. Marfels for the courtesy he has shown in enabling us to lay this series before our readers in so complete a form.

"On Memorandum."

THE LEGAL MEANING OF THIS TERM AT LENGTH SETTLED.—THE CASE OF ALFRED H. SMITH & CO. vs. HENRY CLEWS.



THE CASE of Alfred H. Smith & Co. vs. Henry Clews, which has been in litigation for the past six years, having been three times tried with varying results, has at length been decided in favor of the plaintiffs, and a conclusion reached of transcendent importance to the jewelry trade. The whole question really turned on the meaning that was to be attached to the term "on approval" as used in the trade. The law had never before taken cognizance of the specific meaning of this term. Now the whole vexed memorandum business is set at rest by this verdict. Chas. H. Woodbury, attorney for Alfred H. Smith & Co., whose conduct of the case has been masterly, gives the following history of it:

Prior to the 11th day of April, 1879, Henry Clews requested a man by the name of Eliza Meyers to obtain for him a pair of diamond ear rings, which he proposed to buy for his wife. This man Meyers was a broker in stocks in Wall street, and was also in the habit of carrying about diamonds to dispose of if he was able to do so among operators in the street.

Meyers obtained from other diamond brokers several pairs of diamond ear rings and showed them to Mr. Clews, but they did not please him, and finally Meyers came to B. W. Plumb, the diamond broker, and told him that he was unable to find any diamonds to please Mr. Clews, and Mr. Plumb told him that he had exhausted all his stock, but he would take him to a house where there was a large stock, and where he would have a larger assortment to choose from.

Accordingly Mr. Plumb took Mr. Meyers to the house of Alfred H. Smith & Co., diamond importers, then carrying on their business at No. 14 John street, but whose place of business at present is No. 182 Broadway. Mr. Plumb introduced Mr. Meyers to Mr. Smith, who had never seen him before, and who had no acquaintance with or knowledge of him. Mr. Meyers stated that he was trying to find

a pair of diamond ear rings to see if they would suit Mr. Clews. He looked over the stock that was shown to him, and after examining the stock he selected a pair of diamond ear rings that he said he thought would suit Mr. Clews, and wished the privilege of taking them to show them to Mr. Clews. Mr. Smith said he would think about the matter, and if he concluded to deliver them to him he would send them down the next day.

The next morning Mr. Smith delivered the diamonds to Mr. Plumb to be delivered to Mr. Meyers, and Mr. Plumb took them down on the 12th of April to Mr. Meyers and delivered them to him, taking from him at the time a receipt in this language:

"New York, April 12, 1879.

Received from Alfred H. Smith & Co., by their representative, B. W. Plumb, a pair of single stone diamond ear knobs, 10 $\frac{1}{8}$ karats, of the value of \$1,400, 'on approval,' to show to my customers, and knobs to be returned to said A. H. Smith & Co. on demand.

E. MEYERS "

Mr. Meyers delivered these stones to Mr. Clews, and Mr. Clews had them in his possession and under his consideration for several weeks, and finally purchased them from Mr. Meyers, according to Mr. Clews' statement, on the 3d of May for the sum of \$1,100, said \$1,100 to be paid to Mr. Meyers by giving to him a pair of diamonds which he, Mr. Clews, already owned, at the price of \$450, and giving to Mr. Meyers credit on his, Mr. Clews', books for the balance, \$550.

On the afternoon of that same day Mr. Meyers came to Mr. Clews, so Mr. Clews said, and told him that he had sold some stock short and the market had risen, and that he wanted Mr. Clews to buy the stocks to fill these short sales, and charge the difference in the cost of the stocks to him Mr. Meyers. This Mr. Clews did, and it absorbed \$550 of the balance to Mr. Meyers' credit. The remaining balance of \$100 was never paid by Mr. Clews to Mr. Meyers, and it still remains to the credit of Mr. Meyers on Mr. Clews' books.

Whether this transaction between Mr. Meyers and Mr. Clews took place before or after Mr. Clews was notified of Alfred H. Smith & Co.'s claim to the diamonds is uncertain. Mr. Clews said that it was before. According to Mr. Meyers' evidence it could not have been before Mr. Clews knew of this claim. But be that as it may, Mr. Smith, without being able to give the exact date when he first saw Mr. Clews, said that within two or three weeks after the 12th of April he found Mr. Meyers in New street. Mr. Smith had been trying to find Mr. Meyers for several days in order to get his diamonds. He had not seen or heard from him since the 11th day of April (when Mr. Meyers first called upon Mr. Smith). Mr. Smith demanded the stones of Mr. Meyers, and was then told by Mr. Meyers that he had deposited the stones with Mr. Clews as collateral security on stock transactions. Mr. Smith immediately sought out Mr. Clews and demanded the diamonds from him, telling him he, Smith, was the owner of them, and that Meyers had no right to dispose of them. But Mr. Clews told Mr. Smith he had bought the diamonds and he refused to surrender them. Accordingly Mr. Smith brought an action against Henry Clews for the recovery of the diamonds.

The action was first tried in January, 1883, before Judge Lawrence and a jury, and the plaintiff had a verdict for the value of the diamonds. Upon that trial no evidence was given of the trade meaning of the words "on approval." That verdict was affirmed at the General Term. The court held upon the trial and at the General Term that the receipt given by Mr. Meyers did not authorize Mr. Meyers to part with the title to the goods; that the utmost he could do would be to show and return the diamonds. But Mr. Clews appealed to the Court of Appeals, and when the case reached the Court of Appeals that court held that the case was not to be determined upon the terms of the receipt alone, but that there was some evidence in the case, as the evidence then stood, that Alfred H. Smith & Co. had delivered the diamonds to Mr. Meyers with the knowledge that Mr. Meyers had previously sold diamonds belonging to them to Mr. Clews, and that as, according to that evidence, they

had received the money paid by Mr. Clews for those prior stones, both Mr. Meyers and Mr. Clews and Alfred H. Smith & Co. might be reasonably supposed to have delivered the stones mentioned in the receipt for the proposed sale, and not merely to show them and return them. The court, therefore, reversed the judgment and ordered a new trial.

The case came on for a new trial before Judge Donohue and a jury in November, 1887. Upon that trial it was shown conclusively that the man Meyers had never sold any stones belonging to Smith & Co. to Clews prior to this transaction of May 3, 1879, and had never received any money from Mr. Clews and paid it to A. H. Smith & Co., and that A. H. Smith & Co. had never known Mr. Clews until Mr. Smith made the demand for these particular diamonds about the 3d of May, and had never had any transaction whatever with Mr. Meyers. This removed the basis of the reasoning given by the Court of Appeals in reversing the prior judgment.

The offer was then made to prove that the words "on approval," mentioned in the receipt, have a recognized trade meaning, which is that the person to whom goods are delivered "on approval" has not the authority to sell the same or to pass the title thereto; that he can only show the goods to his customers, and, if they please the customers, to report to the owner; and that the title does not pass until the owner either gives a bill of sale of the goods or authorizes the party to sell them.

Judge Donohue refused to permit such evidence to be given unless the trade meaning was brought home to the knowledge of Mr. Clews, and as this could not be shown he dismissed the complaint. The plaintiffs appealed to the General Term, which affirmed the judgment. The plaintiffs then appealed to the Court of Appeals for the second time.

When the case was reached in the Court of Appeals in March last, the court held that this appeal presented facts entirely different from those presented in the former one, and that the former opinion was not controlling; that the evidence offered as to the trade meaning of the words "on approval" was competent and should have been received. They held that the question to be decided was, what was the legal power of Mr. Meyers? If he was legally authorized to sell the goods then he could sell them, and a purchaser in good faith would acquire title. If he was not authorized to sell them, then a purchaser from him could not acquire title to the goods. It all depended upon what was the legal power of Mr. Meyers. The court directed a new trial.

The case came on for trial the third time before Judge Beach and a jury on the 13th day of June last, and it continued until late in the afternoon of the 17th of June. The plaintiffs introduced the same evidence that was introduced on the second trial before Judge Donohue, and then they introduced the evidence of the trade meaning of the words "on approval." They called from twenty to twenty-five witnesses, embracing the large retail houses in the diamond trade, brokers in the diamond trade, the importers, wholesale dealers and jobbers. There was no variation in the testimony of these different classes of dealers as to the trade meaning of the words "on approval." They said that the words "on approval" and "memorandum" mean the same thing in the trade, and that meaning is that the title to the goods remains in the owner until the owner gives a bill of sale or directly authorizes the party to whom they were delivered to sell the same.

The defendant called a few witnesses who testified that it was their custom to deliver diamonds "on approval" or "on memorandum" to brokers; that they delivered goods "on approval" or "on memorandum" to other dealers, and when they delivered goods to brokers they did it for the purpose and with the understanding that the broker might sell them. But there was no variation as to the meaning of the words "on approval" or "on memorandum" among any of the witnesses.

The case was thoroughly tried, and was submitted to the jury in

an able charge by Judge Beach at the close of the trial, late in the afternoon of June 17. The jury were out about half an hour and returned a verdict for the plaintiffs, awarding \$1,926, including value, interest and depreciation. Mr. Clews' counsel gave notice of an appeal.

The Jewelers' and Tradesmen's Company.

GILBERT T. WOGLOM, *President.*

THOMAS A. YOUNG, *1st Vice-Pres.*

EPHRAIM S. JOHNSON, JR., *Sec'y.*

SHUBAEL COTTLE, *2d Vice-Pres.*

SAMUEL W. SAXTON, *Treasurer.*

BOARD OF DIRECTORS.

JAMES A. SMITH, M. B. Bryant & Co.
 EPHRAIM S. JOHNSON, Treasurer, E. S. Johnson & Co.
 SAMUEL W. SAXTON, President Solid Link Chain Mfg. Co.
 CHARLES A. FOWLER, Fowler Bros.
 JOHN C. DOWNING, Downing & Keller.
 SHUBAEL COTTLE, President S. Cottle Company.
 THOMAS A. YOUNG, Ex-President National Association of Commercial Travelers;
 Chairm'n Legislative Committee and Vice-President of the Commercial Travelers' Ass'n, State of N. Y.; President Traders' and Travelers' Union.
 CHARLES F. ROBERTS, M. D., *Medical Director*, 69 E. 54th St., N. Y. City.
 SAMUEL A. BALDWIN, W. E. White & Co.
 GILBERT T. WOGLOM, Gilbert T. Woglom.
 WILLIAM B. KERR, Kerr & Battin.
 SAMUEL SONDEHEIM, Bruhl Bros. & Co.
 Counsel, JAMES M. HUNT, (of Rudd & Hunt) 31 & 33 Pine Street.

As a necessary item in life, life insurance has taken its place in the market in common with merchandise. The time has arrived when the necessity of reliable life insurance is generally recognized, so much so that it is no longer a question with the average business man whether he will purchase the article, but whether he is physically qualified to secure it.

The privileges and benefits of membership in the Jewelers' and Tradesmen's Company which have been extended to the fifteen or twenty thousand jewelers of this country, are being promptly availed of by those who are ready to save their entrance fee of from five to twenty dollars. Up to the present an aggregate of over two million dollars insurance has been written, at a rate that promises in a few weeks to reach the point whereupon the full regular entrance fee will be required from all applicants without exception. The officers desire to emphasize this statement in order that the very many who have expressed their desire to join (of whom many will doubtless procrastinate beyond the time set) may have been duly warned through the columns of THE JEWELERS' CIRCULAR.

During the first three weeks of June, the following named have been admitted to membership: William H. Jennings, with Theodore B. Starr; Nathan A. Ulman, with United States Law Association; Thomas R. Creede, with J. Rosenthal & Co.; William Cooper, with Hayden W. Wheeler & Co.; William L. Meerbott, Jr., Peter Conrad, Frank D. Reilly, with Crofut & White; Maurice L. Powers, with Falkenau, Oppenheimer & Co.; Abraham Levy, William H. Snellgrove, Morris Langer, Berthold Veit; Frank J. Leibmann, with E. P. Reichhelm & Co.; Chas. R. Gardner, all of New York city; Egbert B. Schwingler, Shickshinny, Pa.; George D. Van Horn, Paris, Tenn.; Charles F. Winter, River Falls, Wis.; John L. Davison, Mason City, Ill.; Gustave Godefroy, Britt, Ia.; John J. Salfinger, of J. S. Allen & Co., Minneapolis, Minn.; Charles C. Carroll, Herman Crondahl, Hartford, Conn.; Erastus K. Shaw, Manhattan, Kan.; Carl Mayer, Austin, Tex.; James W. E. Roby, M. D., Brooklyn, N. Y.; John H. Tappin, Troy, N. Y.; Oswald McMillan, Ernest Rosenthal, Charleston, S. C.; James Coatsworth, J. Coatsworth & Son, Galena, Ill.; Carl Bertram, Tulare, Cal.; Jacob L. Schweizer, Selma, Ala.; Chas. E. Graves, J. B. Chambers & Co., Chicago; Robert Ziebell, Milwaukee, Wis.; John G. Batte and Julius Dorenfield, with John G. Batte, Belton, Tex.; Henry J. Fruchy, Dupont, Ohio; Emory Hall, Dallas, Tex.; Elijah Vanderwerken, Clasen W. Hoyt, Clark & Hoyt, Daniel M. Fisher, Charles R. Toms, Alexander Weed, Stamford, Conn.; Daniel H. Blinn, D. H. Blinn & Co., Waterbury, Conn.; Erza L. Hall, Green Bay, Wis.; Louis W. Kurten and John C. Meyer, New Orleans, La.



SAINT ELOI, a famous goldsmith of the middle ages, lived about 650 A. D. He was canonized for his many pious deeds. His modern namesake is depicted above.

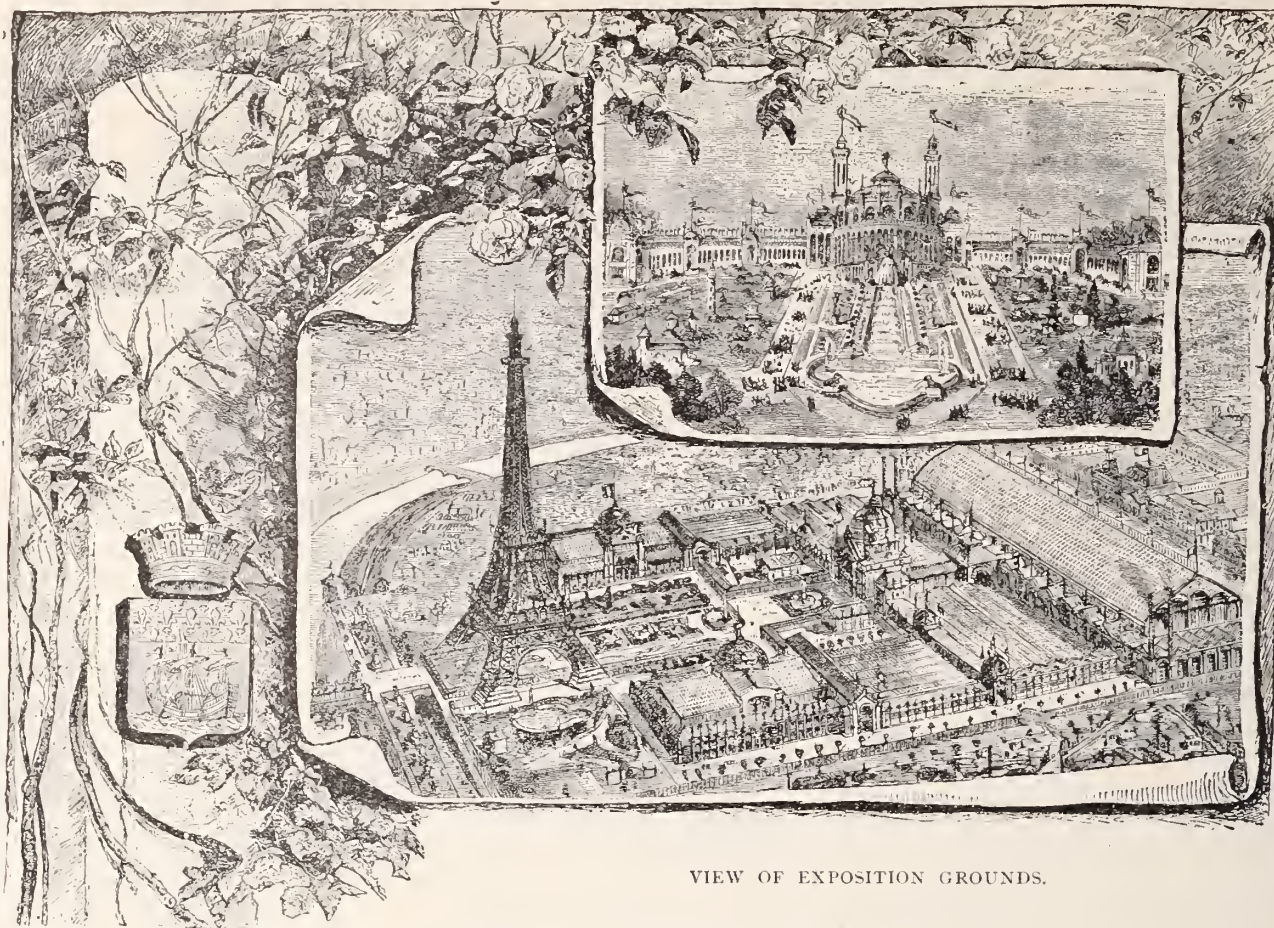

VIEW OF EXPOSITION GROUNDS.

Glimpses of the Exposition.

THE GORHAM COMPANY'S EXHIBIT.

PARIS, June 5th, 1889.

I cannot resist beginning this article with an admiring survey of the Gorham Mfg. Co.'s exhibit. Not only my own impression, but the unanimous remarks of the visitors compel me to do so. It is undoubtedly a fair and comprehensive exemplification of American skill and design in the production of silverware, and fully realizes the theory and aim of the company, namely, to combine in every article produced in its works, however commonplace, artistic beauty with practical utility. This principle actuating the company, designers, artists and artisans of the most pronounced skill have been sought for throughout the globe, and their energies engaged for its realization. That success has crowned their efforts is fully attested by the magnificence of the display ensemble, and the elegance of execution and truthfulness to nature in design of the individual pieces. While artisans of recognized reputation from England, France, Russia, Germany and other countries other than United States are employed, the company are by no means wholly dependent upon this force; experience has taught them that native material for equally as good workmen exists, and a force of highly skilled workmen apprenticed in their own shops under progressive American methods has produced many of the most elaborate articles. Carried off by the prevailing current, I sent you a telegram, which, I hope, you received in time for publication in your last number. The success of the Gorham Co. at the Paris Exposition is not likely to surprise you. Yet its suddenness with so varied, so heterogeneous a public, seems almost unprecedented. Let us inquire into the causes of it.

First of all, the whole display is cleverly arranged and distributed so that not a single piece can possibly fail to produce its intended effect. The visitor, who paces slowly outside along the glass cases, looking with interest at their contents, arrives by degrees at the entrance, and then the century vase, resting on a table at a short distance, calls and retains his attention. Struck at once by the importance of the work and anxious to examine it thoroughly, he steps into the place and inspects all the details of that truly American masterpiece. The

bold and artistic effect of the ensemble and the perfect finish of all the parts provoke his unreserved admiration. He feels that he must see the whole exhibit, and the natural result is one of complete satisfaction, generally conveyed to Mr. Houghton in the warmest terms.

I dare not attempt to give you even a summary description of those countless articles, two of which are reproduced here, but I feel it compellant to give you detailed descriptions of a few. The tureen illustrated herewith, is a piece of an exquisite repoussé dinner service—a collection that is universally admired by visitors. The designs are prominently East Indian, and are varied in the many pieces, no two being alike. The repoussé decoration is exceptionally fine. The general opinion obtains, that such a set, for beauty and variety of design, has never been produced in America.

Then there is a tea service, also in East Indian design, that attracts much attention. All the pieces are massive in character, and the designs are consistent with the peculiarity of the form of each piece. Thus, each is different, but there is a general harmony of style.

Right near this is an individual piece of noticeable beauty. It is a champagne pitcher, that is illustrated in this article. It stands about 15 inches in height, and its base is about $3\frac{1}{2}$ inches in diameter. The designs are etched on a black oxidized background. The whole, though massive in reality, by reason of its finely proportioned dimensions and its delicate curvatures, produces in the mind of the observer an idea of exquisiteness and delicacy.

And then there are other dinner and tea sets modelled after Greek designs. Noticeable is a salver, in the center of which are two faithfully executed figures of a Grecian woman in a sitting posture, and a male Greek, evidently young, waiting upon her. The styles of decoration of these sets are chasing and engraving. There are at least four of these sets, all different in form and decoration. A group of toilet articles and *articles de vertu* commands much observation and excites much comment. Scent bottles, manicure sets, puff boxes, check cutters, calendars, inkstands and articles too numerous to specify abound in profusion.

A patriotic piece, an American shield, designed and modelled by F. A. Heller, has been exhibited before, at the Centennial Exposition of 1876. The plan is a medallion, enclosed by four panels, the top panel containing the national shield of stars and stripes, an eagle and olive branch and streamer bearing the national motto, "*E pluribus unum*," the right hand panel representing a figure of Liberty bearing in her hand the wand of Mercury, the left hand panel containing the figure of Justice, and the bottom panel symbolizing Fraternity by the embrace of a pair of Cupids. The medallion contains a profile face of Columbia, semi-Indian in expression; she wears a necklace and other ornaments indicative of the fondness of the Indians for adornments.

And so I could go on almost indefinitely describing tea sets, punch bowls, tureens, pitchers, candelabras, flower vases, toilet sets, etc., all different in style and decoration, which are assembled here in a most tasteful arrangement, but I must defer completion to future numbers. The leather articles, also, with their handsome silver

THE TIFFANY DISPLAY.

Tiffany & Co.'s magnificent display of jewelry, which you fully described in your April issue, throws the public into rapture from the very instant they enter their extensive apartment, all fitted up in fine rosewood. Ladies are at once attracted by the elaborate corsage garniture (a study from lace work), composed of a network of more than 2,000 diamonds. It is elegantly arranged on a bust covered with dark brown velvet, showing the whole effect. Held on the right shoulder by a very large rosette, it drops—four inches wide—and is caught by another rosette on the center of the bodice, then falls down to the waist on the left side where its course ends.

Lovers of handsome stones linger in deep admiration before the splendid diamond necklace, valued at \$175,000, and described in your April number. The pendant, weighing $25\frac{3}{8}$ karats, is proclaimed to be the finest stone of that size in the whole Exhibition.

A glorious head ornament, which might have been designed for



SILVER TUREEN, REPOUSSE, EAST INDIAN DESIGN. GORHAM MFG. CO.

ornaments, present a wonderful array. Several pieces have been sold already, among which a very original coffee pot on a square tray, bought by M. Luis de Rezende; and important orders are given by continental firms.

I must conclude this brief installment of the Gorham Co.'s exhibit with saying that it is impossible to see a greater variety of silver articles in the Paris Exhibition. As to the workmanship of all those pieces, from the smallest item of a toilet set to a large-sized candelabra, or from a pansy in enameled silver to a prize cup, every one of them can bear a close inspection. You may examine attentively the whole contents of those huge cases in which I have seen complete table sets, you will find nothing in them that the most acute criticism could not approve of.

My personal remarks are confirmed by the thoroughly favorable impression which the Gorham Co.'s exhibit has made on several French silversmiths of note.

the central piece of a Persian Shah's tiara, consists of sapphires and diamonds tastefully contrasted. An aigrette of yellow spun glass, shooting up straight in front, but of a soft and silky appearance, gives it a thoroughly Asiatic effect.

A marvellous necklace is one made of diamonds, among which are five yellow ones. The largest of these (placed at the base of an elaborate pendant ornament, enlivened on each side by clusters of garnets) is 77 karats in weight.

If I were to mention all the pieces which fascinate the visitor, I should have to give you a complete catalogue of the whole exhibit, which would be a repetition (only varied by the remarks of the public) of what has been already seen in this paper. Let us quote at random: A beautiful necklace formed of diamond ivy leaves.—A lovely pearl necklace with introduction of large emeralds.—A tiny watch, circled with brilliants, set in the heart of a wild rose, the leaves in green chased gold sprinkled with diamond dew-drops.—A bonbon-

nière in rock crystal bound with gold wire and set with turquoises.—A match box in Chillkat Indian decoration, green and still blue enamel on yellow gold.—A bracelet of arrow-shafts with Ceylonese-cut sapphires drilled through, the end swinging.—A pendant bon-

suspended from a necklace in pierced work, set off with brilliants, etc., etc. I shall describe in my next some of the silver articles.



CHAMPAGNE PITCHER. GORHAM MFG. CO.

bonnière representing a bunch of violets, with a diamond bow knot; it opens at the top as a flacon, underneath which there is a tiny place for a photo.—A black pearl and diamond pendant hanging from a dainty chain of black and grey enamel with intervals of diamonds;



DIADEM. VEVER.

the largest of those pearls weighs 80 grains; it comes from the Gulf of California and is valued at \$28,000. A cat's-eye brooch of a Burmese style, with an addition of rubies and diamonds, the whole

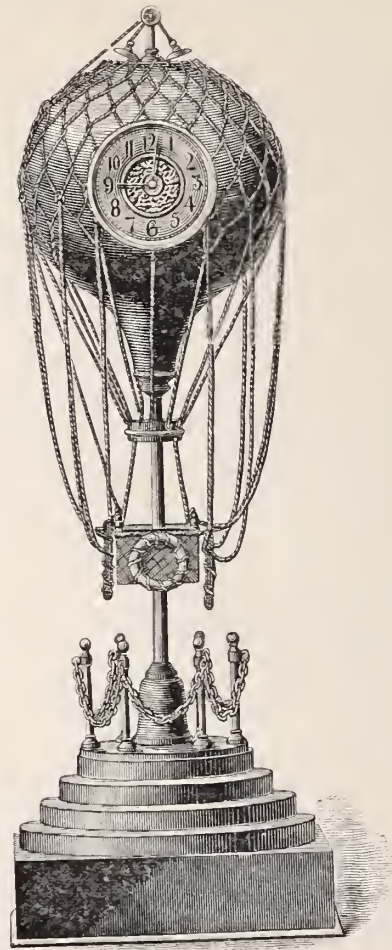

MECHANICAL CLOCK.—BALLOON. DIETTE & HOUR.

The unparalleled variety of gems and the thorough originality of designs makes of 'Tiffany & Co.'s place at the Exhibition a kind of



MECHANICAL CLOCK.—THE EARTH. DIETTE & HOUR.

royal treasure house where the rarest jewels in the world are assembled, and it is always with an obvious reluctance that visitors leave that magic circle.

The important exhibit of precious stones found in America is placed in the very center of the United States' Court. It has been arranged under the direction of George F. Kunz (special agent for the U. S. Exposition Committee), which has made of it one of the chief attractions to the Champs de Mars. This highly interesting display occupies a circular rosewood case 27 feet in circumference, and is raised on a pavilion, at the base of which are placed all around sofas separated by steps. A continual procession of people walk up

such as ought to fill up the hearts of that great people with a legitimate pride, France, on the other hand, feels highly honored by it.

THE ENGLISH SECTION.

Although the English section occupies a very large place, British jewelers and silversmiths are far from being represented to the extent they ought to be. I regret not to see there Elkington & Co., Mappin & Webb, etc., etc. Yet I must confess that the very elegant stall of the Goldsmith and Silversmith Co. (of London) contains many pieces worthy of notice. Besides a necklet worth £20,000 having a large black diamond (worth £2,500) circled with small white ones, as a pendant, they exhibit a complete silver tea set of a quaint design,



CORSAGE GARNITURE. (A STUDY FROM LACE WORK.) TIFFANY & CO.

to see the contents of the capacious case, and utter laudatory remarks in all existing languages. Mr. Kunz, whose time is more than fairly employed in answering endless questions, will kindly give me shortly a few details about that wonderful exhibit.

I shall mention in my next article (at length) the display of the Meriden Britannia Co., which is a very important one, and contains some remarkable pieces. And I have still to describe the displays of Leroy W. Fairchild Co., H. H. Heinrich, Kent & Stanley, J. F. Fradley & Co., Trenton Watch Co. and others, which, no doubt, I shall be able also to do next month.

If the participation of the United States to the Paris Exhibition is

said to be the exact copy of Queen Dunc's service. Very curious is their tankard, with the British lion on the handle. The whole piece, in frosted silver, is of a simple shape and covered with 37 historical English coins, from William the Conqueror's time to the Queen's Jubilee. Two goblets, adorned in the same way, accompany it. The Polo Cup, an elaborate piece in massive silver, is very ornamental.

THE FRENCH SECTION.

In the French section of horology I have been particularly attracted by two exhibits of an opposite character, both equally interesting. Diette & Hour's display consists of original clocks, in all kinds of shapes and decorations, reminding us chiefly of scientific

inventions. This place is really full of life. Those steam engines, wind and water mills, light houses, etc., showing a dial, a barometer, and here and there a thermometer, are all in motion. Very pretty is their balloon turning gently around, and so is the revolving sphere. The most trivial details of these pieces are well calculated to give the real effect. People who prefer something elegant will inspect with pleasure the Sedan chair in bronze, richly decorated, with a *fleur-de-lis* at the top. The dial, in front, is daintily formed, and on each side face there is a pretty miniature, one being a portrait of Mlle. de la Vallière and the other one that of Princess de Lamballe. There is also a sledge in oxidized bronze partly gilt, resting on a beautiful onyx stand, etc.

M. Planchon's display is utterly different, since all the models exhibited by him are reproductions of ancient works. It begins with a clepsydra, as described by Vitruvius and drawn by Perrault, which

(tration) with a yellow diamond weighing 54 karats in the center, reminds me too much of that of Fouquet in 1878. It is the only fault I find with it. M. Boucheron's exhibit is very remarkable, yet I do not like his diamond vine branch. The leaves are of a good design, but the grapes hardly look natural. If diamonds cannot represent them it is of no use attempting it. M. Lefebvre's anemones, whose petals are made in enamel, with a diamond in the heart of the flower and brilliants all over the stalk, have a charming effect.

In the silversmiths' section, which I must carefully visit next month, there is a lilliputian reproduction in silver and gold of the *Bourse*. All the details of that important building have been patiently copied and delicately chased. It is surrounded with 64 gas lamps which can be lighted up. This piece of a special character, which alone a lucky speculator might think of purchasing, is valued at \$10,000.

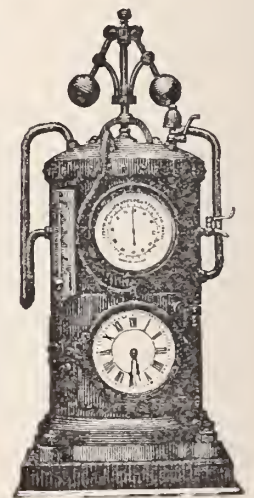
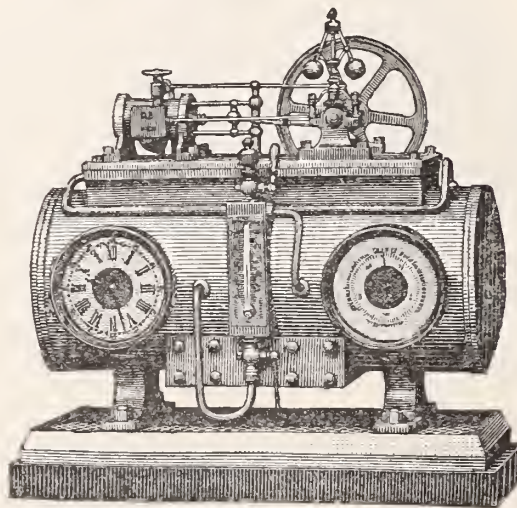
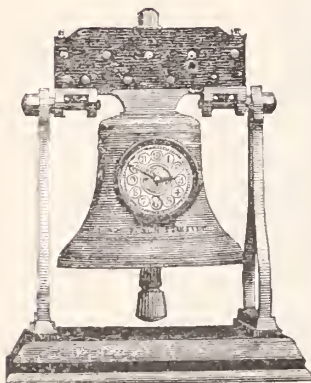
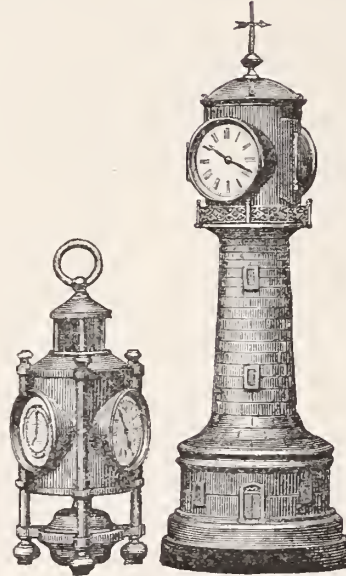
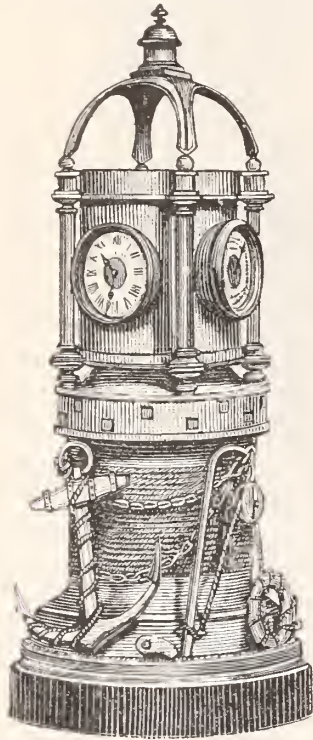

MECHANICAL CLOCKS. DIETTE & HOUR.

is neatly built, with a symmetrical arrangement of wood, brass, marble and mosaic. Next, the visitor ought to examine a clock made of worked iron, in the gothic style; then several other ones belonging to the sixteenth century and which are copies of Italian, Spanish or French timepieces, and finally have a close inspection at those lovely Louis XIV. and Louis XV. clocks, some of them decorated in *Verins-Martin*.

I can only pay this time a short visit to the section of jewelry. Nearly all the displays contain something worth looking at and deserving mention. Yet, I must say that M. Vever is especially favored by visitors. I need hardly speak of his pearl necklace worth \$140,000. I have a special liking for a diamond branch of roses, perfectly imitated as to the folds and the droop. Very pretty, also, is a knot entirely made of gems. His diadem (as seen in the illus-

A chaser, Jules Brateau, exhibits some plates and other articles in tin, most daintily worked. That refined artist has attempted to revive the beautiful style invented by François Briot, a celebrated French silversmith of the sixteenth century, well known to all through his ewer and basin in chased tin on view at the Musée de Cluny. The circular designs, with numerous groups of figures, particular to that genre, is of an elaborate and yet delicate effect. J. Brateau seems to have special processes which, the model being once created, allow him to reproduce it on a cheap scale, as some of his plates cost only \$10.

I have seen some lovely pieces of a character *sui generis* in the Russian section, and will not fail to describe them. Italians seem anxious to revive the fashion for coral, and Bohemia, with her pretty crystals, is everywhere in the Austrian court.

FRANCUS.

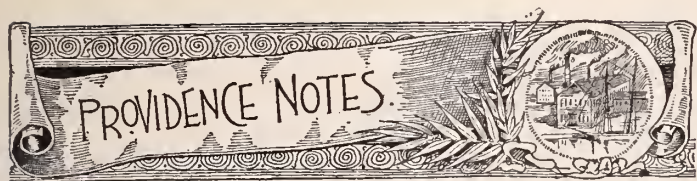

[FROM OUR SPECIAL CORRESPONDENT.]

PROVIDENCE, R. I., June 20, 1889.

The annual field day of the New England Manufacturing Jewelers' Association was held at Rhodes-on-the-Pawtuxet, on Friday, June 7. The attendance was fair, as also the weather, and the outdoor sports and the excellent menu of mine host Rhodes were thoroughly enjoyed by all. Base ball, foot ball and rowing were good appetizers, and full justice was done at the board. Dinner was served at about 3.30, after which Vice-President Edwin Lowe asked the members to rise and drink in silence to the memory of their late President, Alfred S. Potter. The members then assembled up-stairs and Vice-President Edwin Lowe called the meeting to order. H. F. Carpenter, Treasurer, read his annual report. Secretary John A. McCloy read the report of the last meeting and also the annual report, announcing that during the past year three members had died: President Alfred S. Potter, V. H. Blackinton, of Attleboro Falls, and Charles Downs. He reported forty-three members in good standing. The election of officers resulted in the choice of Edwin Lowe for President, A. A. Bushee, first Vice-President, W. D. Fisher, second Vice-President, John A. McCloy, Secretary, and Horace F. Carpenter, Treasurer. The old Executive Committee, consisting of J. M. Buffinton, Frank T. Pearce and Henry G. Smith, was re-elected. The resignation of Hiram Howard was then accepted, and Wm. H. Riley, of Riley, French & Heffron, of North Attleboro, was elected a member. A motion that when the meeting adjourn it be at the call of the Executive Committee some time in July to consider whether to continue the association or disband it, was made. The motion was finally carried, but a majority of the members present favored keeping the association alive. The members and guests present were: Edwin Lowe, W. D. Fisher, G. E. Fisher, W. H. Riley, H. F. Carpenter, O. C. Devereux, John A. McCloy, John M. Buffinton, Frank T. Pearce, Henry G. Smith, Wm. F. Leeder, Joseph H. Fanning, P. F. Parsons, John W. Case, Stephen Albro, J. J. Fry, B. A. Ballou, Martin L. Read, Chas. A. Stahl, Jr., Wm. H. Richmond, W. S. Hough, Jr., Benj. L. Hall, F. H. Bryant, F. Buffinton, Geo. B. Angell, David Bernkopf, S. W. Albro, C. F. Harris, Col. L. Stephens, C. H. Mathewson, of the *Jewelers' Weekly*, W. B. Frost, of the *Manufacturing Jeweler*, J. W. Watson, of the *Jewelers' Review*, E. P. Ingersoll, of THE JEWELERS' CIRCULAR, and L. R. Southworth, of the *Providence Journal*.

E. C. Ostby, of the firm of Ostby & Barton, ring makers, returned from Europe June 3 on the *Gascogne*, having had a very enjoyable trip.

Davis & Emerson have purchased from Alexander Milne & Co., Newark, N. J., the patents and plant for manufacturing the Monarch solderless collar button, and have transferred the plant to Providence. They will manufacture this button with increased facilities.

A. L. Sweet, formerly of the firm of Sweet, Fletcher & Co., has become a full partner in the firm of G. B. Willis & Co., of which he was a special partner. Fletcher, Burrows & Co. is the new style of Sweet, Fletcher & Co., Henry Fletcher, Edward G. Burrows, Jr., and John Fletcher constituting the firm.

Foster & Bailey have been making some alterations in their office and shipping department owing to increase of business. One of the improvements is a cosy little private office. This enterprising house is constantly adding to its mammoth line of Mount Hope buttons, which are becoming more popular if anything, and the new companion button, the *Omega*, is likely to run abreast of the older favorite.

Hiram Howard, of Howard & Son, was recently elected a director of the Rhode Island School of Design, in which he has taken a warm interest since its inception. Mr. Howard is mentioned as a possible candidate for Mayor on the Democratic ticket next election. Stephen C. Howard, the junior of the firm, has returned from his long western trip much improved in health, and laden with a large number of orders which he could not well resist taking, even though he was on a pleasure trip.

The plant and good will of the firm of Atwood & Co., No. 18 Nassau street, successors to Atwood & Colwell, has been purchased by the Providence Stock Co., who will continue to manufacture a full line of the well-known "A. & C." chains, adding new patterns and increasing facilities generally.

W. L. Ballou, 80 Clifford street, returned from Europe recently much invigorated by the voyage.

"Barney" Crossin, of Crossin & Tucker, is celebrating the arrival of another daughter, and says he now has four queens, a full hand.

The business of the late Charles Downs, 61 Peck street, will be continued under its present management.

Towne & Ingraham is the name of a new concern that has just commenced the manufacture of rolled plate chains at 29 Point street. Mr. Towne was formerly a member of the firm of Dunham & Towne, now E. H. Dunham & Co.

Mr. Hancock, of Hancock, Becker & Co., who is in the West, is sending in encouraging reports on their new line of samples. They have been granted a patent on a new setting, illustrated elsewhere in this issue.

After an extended trip West, Fred. A. Ray, representing J. W. Grant & Co., may be expected at the Astor House by or before the 7th of July. He is now showing up the merits of the "G. & Co." chain, a line fast pushing itself into notice as one of the finest and largest lines of ladies' and gents' chain in rolled plate and solid silver that can be found in the market. These goods are sold at exceedingly low figures and all styles are exactly as represented, every chain being warranted to give satisfaction. They sell only to the jobbing jewelry trade.

Howard & Son are nothing if not original, and the circular they have sent out to announce the coming of their new button, the "King of Korea," would make a pilgrim from the "Flowery Kingdom" feel homesick. The "King of Korea" promises to be just as startling a novelty in the button line as the circular is in its province.

To protect their customers from inferior goods, Hamilton & Hamilton, Jr., the chain manufacturers, of 7 Eddy street, have adopted a series of tag marks to accompany their well-known trade mark, *H. H., so that the retailer, as well as the jobber, may know the exact quality of the chain he is buying. These quality marks, which are all illustrated on another page, should be carefully studied and memorized by all who want a good article. Every swivel bears their trade mark plainly stamped thereon.

Hutchison & Huestis have a very useful little advertising novelty which they are distributing to the jobbing trade.

Chas. F. Irons, maker of masonic marks and emblems, 102 Friendship street, has just had a design for a badge accepted and adopted by one of the prominent secret orders.

The seamless filled gold chains made only by Kent & Stanley, 7 Eddy street, have become a staple in the trade here, so they are looking for more worlds to conquer, and are accordingly going to exhibit their product at the Paris Exposition next month. Mr. Brainerd, their representative, is already on his way thither, and after superintending the exhibit he will make a tour through the principal European countries to introduce these goods to foreign buyers.

H. A. Kirby, of Kirby, Mowry & Co., Providence, R. I., returned from Europe in the early part of the month, after a short but pleasant trip. He brought with him large purchases of diamonds, precious

stones and specialties which are now being offered to the trade, in fancy stone rings and novelties in scarf pins, lace pins, drops, etc. Mr. Mowry will, as usual, call on the trade in person to deliver an important message.

F. I. Marcy & Co., are in the field with a brand new line of American lever buttons, which are selling with all the old time snap.

Geo. W. Parks, manager of the New York office of the Sterling Co., has been here this month getting out novelties for the summer and fall trade.

S. A. Baldwin, W. E. White & Co.'s representative, is on his first trip West.



[FROM OUR SPECIAL CORRESPONDENT.]

ATTLEBORO, June 20 1889.

Business seems to be going along with a rush; salesmen out on the road are meeting with very good success. Orders have now been coming in for two weeks, and there is hardly a shop in town that is not running on full time. It is a very satisfactory condition of affairs, especially for the employees, although many of them might wish the rush had come a little earlier.

ATTLEBORO.

I believe the sudden boom that struck the business in this town last week was quite a surprise. To be sure, the salesmen all started out on about the same date, but I think they met with better success than was expected.

One of the surprises of this week is the dissolution of the old and well-known firm of W. H. Wilmarth & Co., manufacturers of cheap jewelry. Mr. Wilmarth retires from the firm, while the business will be carried on by E. B. Bullock, the junior partner.

The Bates Button Company is one of the live young firms in this town. It was this firm who first commenced the manufacture of the "pig puzzle" as an article of jewelry, and now they have purchased the right to manufacture a novelty called the "Columbia Necktie Holder."

W. & S. Blackinton are doing a good business. Mr. Sumner Blackinton looks out for the New York trade in a manner which does credit to his executive ability.

Marsh & Bigney is one of the comparatively new firms. Mr. Marsh, who is now in the West, is evidently a first-class salesman, for this firm never seem to lack for orders.

J. M. Fisher & Co. are doing a good business. Their new designs in watch charms are always attractive and find a ready market.

James Blake, of Blake & Claffin, has sent home so many orders that the firm think seriously of running nights.

Two of the most prosperous firms in the Attleboros are undoubtedly Horton, Angell & Co. and A. A. Bushee & Co. It is reported that neither of these have lost an hour except for holidays since January 1. Both do a very large export trade, in fact, nearly their entire products is sent abroad, and as this trade is generally considered profitable, it is fair to presume that both firms are laying by a few dollars every month.

Albert Bushee, of the above firm, received some unwelcome visitors about a week ago. Burglars entered his beautiful residence on County street and took away about \$1,200 worth of solid silverware and a diamond pin valued at \$250.

FALLS VILLAGE.

Since my last letter the well-known firm of Mason, Draper & Co.,

has made an assignment. There are numerous rumors afloat as to their indebtedness, and from the wide difference in the amount given it is very evident that no one knows exactly what it is. I have interviewed C. J. Draper, of the firm, several times, but he says he can make no statement as he is ignorant of what the condition is.

R. F. Simmons & Co. are driving away as usual. Both Mr. Simmons and Mr. Sweet, of this firm, are in rather poor health, but they are always ready to push their business for what it is worth.

NORTH ATTLEBORO.

Here, as well as in Attleboro, business is very much improved since last month. Salesmen have gone onto the road and are meeting with very good success.

One of the most prosperous firms in this section is the firm of F. M. Whiting & Co. Their goods are beginning to be known all over the country, and as they make nothing but sterling work they are getting a most excellent reputation.

F. D. Heffron, late with the firm of H. D. Merritt & Co., has just become a partner in the firm of Riley & French, which concern is to be known hereafter as Riley, French & Heffron. Mr. Heffron is a most popular gentleman and a good salesman, and his new partners may well be congratulated on their new business connection. Mr. E. B. Eaton, formerly with W. G. Hopkins, of Providence, has taken Mr. Heffron's place as representative of H. D. Merritt. Mr. Eaton is well known to the trade and will doubtless make many new friends while retaining the old.

The Wamsutta Hotel, which is really the only place in town where traveling men could stop, still remains closed, no one as yet having leased it.

A new concern, called the French & Franklin Co., has started in the shop building occupied by Riley & French and Clark & Coombs. Mr. Franklin, of the company, was formerly a partner of J. E. Draper. The new concern will make a specialty of silver novelties, and are already in the market with a desirable line for the jobbing trade.

MENDON.



[FROM OUR SPECIAL CORRESPONDENT.]

BOSTON, June 17, 1889.

If there has been a day during the past month that hasn't been showery it has long since slipped from the memory of local tradesmen. The continually bad weather has emphasized the natural dulness of the early vacation season. This is the blossoming time of fakirs, installment dealers and peddlers in all their glory, and the chances are that these business artists are temporarily making a wider margin of profits than the legitimate jewelers. The latter have hard work to coax extensive purchases from their regular patrons, for the Back Bay purse has already suffered from the annual demands of mountain and seashore resorts. However, this is not entirely discouraging. The experienced dealer knows that this is a healthy relapse, and contents himself with the moderate trade supplied by the June weddings, which flourish encouragingly in this part of the country.

The Paris Exposition and its accompanying festivities abroad have drained the society of the Hub of much of its financial strength. The great majority of the tourists will, however, return during August.

Merchants' week boomed things a bit, though perhaps the jewelry

APPRECIATING the value of a neat and salable SINGLE STONE RING MOUNTING, we have concluded to offer this amount for competition among retail dealers, or their employees, believing those behind the counter best able to judge the demands of the market.

The design should combine three qualities: it should be

PRETTY,

ORIGINAL

AND

PRACTICAL.

On September 15, Mr. L. J. Mulford, formerly a manufacturing jeweler, and now Manager of

THE JEWELERS' CIRCULAR,

the oldest and largest journal devoted to the interests of jewelers, will award the prize. He will be assisted by practical jewelers of his own selection.

47 Maiden Lane, New York.

\$50.00

Will be paid for a design of
a SINGLE STONE
Ring Mounting.

Henry E. Oppenheimer & Co.

IMPORTERS OF DIAMONDS.

AND MAKERS OF

FINE DIAMOND MOUNTINGS.

47 MAIDEN LANE,

NEW YORK.

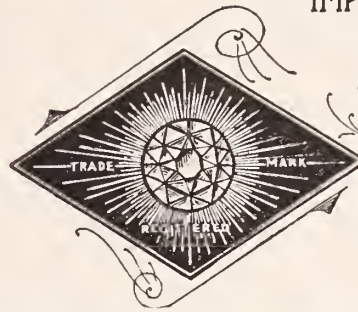

TO WATCHMAKERS:

*WE HAVE FACILITIES FOR CONVERTING ALL KINDS OF FINE KEY-WINDING
WATCHES, SUCH AS JURGENSEN, NARDIN, PATEK, PHILIPPE &
CO., AND FRODSHAM & CO., INTO STEM-WINDERS.*

We are prepared to put Chronographs to Swiss and American Watches
at reasonable prices.

Repeating Work attached to American Watches.

All work done in the best possible manner and at reasonable cost. A trial from the
Trade is solicited.

C. L. BYRD & CO.,

Main & Madison Sts.,

Memphis, Tenn.

trade didn't enjoy so extensive benefits as some of the other lines of commercial business.

Among the old Boston dealers who have taken a new lease of business life is Geo. W. Hagen. Everyone remembers his watch-making establishment in the old Niles Block on School street. He was obliged to vacate during reconstruction, but has re-opened at the old stand in all the glory of its elaborate rejuvenation.

Geo. H. Elson, of Elson & Richards, leaves for Europe on the *City of New York* a week from next Thursday.

Some of the regular dealers are inclined to criticize severely the advertising scheme of Wm. H. Zinn, who recently celebrated the ninth anniversary of the opening of his big department store by selling clocks and jewelry at half price. Such methods as this cannot but injure the legitimate business of those who depend for profits upon a single line of goods.

The Boston Clock Company is acquiring a wide reputation for the delicate accuracy and excellence of its marine clocks. A good many of the yachts that float in Dorchester Bay are provided with them.

The irrepressible Louis Bonnie has opened another store at 783 Washington street. His phoenix-like abilities are the marvel of the trade. The new establishment is well stocked and attractive.

The new Chamber of Commerce building will be erected at the corner of India street and Central Wharf. They say \$300,000 will build it fire-proof.

Among the sufferers in the great Marblehead fire of last winter was J. Frank Summers, who now has part of the quarters of J. Horner, at 45 Winter street, Boston.

Watchmaker Jonathan Brown has found more room to grow in at 50½ Cambridge street.

Everyone in Wareham and a good many wholesalers in Boston know George H. Griffin. He has lately bought the entire business of Wentworth & Co., at Portland, Me. If there's anything in it he'll find it.

Jeweler E. B. Horn has just put \$150,000 into real estate at the Back Bay. He is building several apartment houses.

The Whitney brothers, who came here from Fitchburg nine years ago, have dissolved partnership. A. E. retires and Edwin A. continues the business.

Vincent Lajorme has been confirmed by the Board of Aldermen as Commissioner of Public Institutions.

E. H. Miller & Co. have bought the L. T. Harrington establishment at 102 Court street

The agreement to close at 5 o'clock during the weeks of June, July and August, and at 1 o'clock on Saturdays, has been signed by D. C. Percival & Co., Morrill Bros., Floyd, Pratt & Rounds, Smith & Patterson, Harwood Bros., American Waltham Watch Co, Whitney Bros., M. T. Quimby & Co., J. V. Kettell & Co., Henry T. Spear & Son, and others.

Thos. B. Brogan was refused a discharge in insolvency late last month.

Joseph W. Hanson, who hasn't been in Boston long but who is building up a promising trade, was saved from being victimized recently by the timely arrest of a snatch thief, who gave the name of Michael Sullivan.

They are going to paint Waltham red with fireworks and noise on July 4. The following watch company delegation will have the arrangements of the celebration in charge: J. L. Keyser, C. J. Russell, W. B. Chaddock, W. H. Holland, C. C. Symes, Willard P. Locke, Geo. Dickinson, F. C. Hodgdon and Wm. Caughey.

There have been several swindling cases during the month, but most of them were trivial and unsuccessful.

LEON.



[FROM OUR SPECIAL CORRESPONDENT.]

CHICAGO, June 20, 1889.

In the matter of sales made, the record of the past month is not calculated to awaken much enthusiasm. Both the jobbers and the retailers of jewelry complain of too much leisure; not that trade is any slower this month than last, on the contrary, it is a trifle more active; not that trade has been less in volume than in June of 1888, for the grand total, as compared with a year ago, shows an increase rather than a decline; still no one is busy and summer vacations have begun. Throughout this portion of the country the farmers are jubilant over flattering prospects of good harvests, and country jewelers are correspondingly cheerful in their prophecy of an early and brisk fall trade. The present sales consist mainly of close margin staples. Collections rule satisfactory.

The Johnstown sufferers found no more prompt or generous sympathizers than in the rank and file of Chicago's jewelers. "He gives twice who gives quickly," was realized from the start, and a meeting of the Chicago Jewelers' Association was called so soon as the calamity was known. Not only did this meeting result in the appointment of a committee for the soliciting of funds, but also in the immediate sending of the following telegram to the Governor of Pennsylvania:

"The jewelers of Chicago authorize you to draw on the Chicago Jewelers' Association for \$1,500, payable at the office of the Elgin National Watch Co.; more to follow. (Signed)

H. S. PECK, *President.*"

The subscriptions made to the relief fund were as follows:

Elgin Watch Co.	\$500 00	Gilbert Clock Co.	\$25 00
Meriden Britannia Co.	100 00	A. H. Smith & Co.	25 00
C. H. Knights & Co.	100 00	Towle Mfg. Co.	25 00
Otto Young & Co.	100 00	Rowe Brothers.	25 00
Lapp & Flerhem.	100 00	Juergens & Anderson.	25 00
H. F. Hahn & Co.	100 00	Courvoisier-Wilcox Mfg. Co.	25 00
Benj. Allen & Co.	100 00	M. A. Mead & Co.	25 00
Spaulding & Co.	100 00	C. D. Peacock.	25 00
Waterbury Clock Co.	75 00	Theo. Schrader.	25 00
F. E. Morse & Son.	50 00	Dennison Mfg. Co.	25 00
Morse, Mitchell & Williams. .	50 00	Ansonia Clock Co.	25 00
Shourds, Storey & Kaspar.	50 00	J. B. Chambers & Co.	25 00
H. Mulr's Sons.	50 00	C. F. Happel & Co.	25 00
Simpson, Hall, Miller & Co.	50 00	Prindle & Russell.	25 00
B. F. Norris, Alister & Co.	50 00	Gorham Mfg. Co.	25 00
S. Hyman & Co.	50 00	Lesser & Wirdemann.	10 00
Cogswell & Wallis.	20 00	Joseph & Greenbaum.	10 00
L. Manheimer.	20 00	F. Leonard & Co.	10 00
E. Howard Watch & Clock Co. .	20 00	A. Shakman & Lowenbach.	10 00
Theodore Kearney Company. .	20 00	Kind, Abt & Co.	10 00
H. Oppenheimer's Sons.	20 00	A. Hirsch & Co.	10 00
Employees Benj. Allen & Co. .	15 00	H. M. Carle.	10 00
Employees M. C. Eppenstein & Co.	13 35	Cash.	5 00
M. C. Eppenstein & Co.	10 00	M. Streicher.	5 00
Swartchild & Co.	10 00	W. Hill & Co.	5 00
Weber & Co.	10 00	E. H. Goodrich.	5 00
Glickauf & Newhouse.	10 00	E. W. Burchard & Co.	5 00
Meriden Silver Plate Co.	10 00	Charles T. Wittstein & Co.	5 00
J. H. Purdy & Co.	10 00	A. M. Weinberg.	5 00
Max Young.	10 00	Robert M. Johnson.	5 00
A. & L. Falsenthal.	10 00	William C. Potter.	5 00
Joseph & Fish.	10 00	I. Strelitz & Co.	5 00
R. W. Patton.	10 00	Riehm & Beygth.	2 00
Giles, Bro. & Co.	50 00	Harry Leod.	1 00
Illinois Watch Co.	25 00	M. Solomon.	1 00
F. M. Sproehnle & Co.	25 00		
		Total.	\$2,497 35

Among the questions peculiarly interesting to jobbing jewelers during the month past, the two which have excited the most discussion are *The Tribune's* continued and unwarrantable attack on Mr. Avery, of the Elgin Watch Co., which has been referred to in previous editions of *THE CIRCULAR*, and the raking up of the Clapp & Davies failure. Of course, the readers of *THE CIRCULAR* know that *The Tribune's* recent attempt to prove that the Senate were being unduly influenced by bribery on the part of Messrs. Bunn,

Avery and others, resulted in a disastrous fiasco for *The Tribune* people, it being clearly shown that none of the articles recently appearing in that paper claiming all this contained one iota of truth. Judge Blodget is engaged on the Clapp & Davies muddle; some remarks of his, made within the past few days, rather intimate that the preferences made by them at the time of the failure will be sustained, and that the unsecured creditors stand little chance of ever getting anything. The result will not be made known officially for some time to come.

At the recent annual meeting of the Chicago Jewelers' Association, the following officers were elected: H. S. Peck, President (re-election); M. N. Burchard, Vice-President; A. L. Sercomb, Secretary and Treasurer. The Board of Directors is made up of H. S. Peck, M. N. Burchard, A. L. Sercomb, M. A. Mead, Geo. Sackett, W. Todd, H. Hahn, F. Talbot and F. O. Sproehnle. As has been heretofore stated by your observer, the collection department has grown to be the principal feature of the Association and continues to do efficient work.

The R. Wallace & Sons' Mfg. Co. have established a branch house in this city where a full line of samples of goods of their manufacture will constantly be shown. O. F. Budge is the Chicago representative, and the warerooms are at No. 104 State street.

The Chicago Optical Mfg. Co. has been incorporated with a capital stock of \$20,000, and the avowed purpose of manufacturing and dealing in optical goods. H. W. Duncanson, Lillie M. Duncanson and Thos. P. Thompson figure as the incorporators.

L. & M. Kahn & Co. have sued Raphael & Newman, who failed last November, in the Superior Court, applying for a receiver and an injunction restraining them from the disposal of any property.

One of the contemporaries of THE CIRCULAR states in a recent issue that Forgy & McHenry, of this city, are closing out their stock for the benefit of themselves and their wives and to the detriment of their creditors. No such firm is known here, nor do their names appear in any of the mercantile records, trade directories or city directories.

The name of the R. W. Sears Watch Co. has been changed to A. T. Evans & Co., and the capital stock reduced to \$60,000. As previously stated in these columns by your observer, the Sears' Watch Co. was bought out some time since by one of the Butler Bros., the well-known and wealthy dealers in general store supplies.

The Chicago Horological Institute is now at home in its new quarters in the Owens Building, corner of Dearborn and Adams street. Their new school in this, one of the finest thirteen-story buildings in the country, give them increased room for additional scholars, over fifty being already in attendance.

The representatives of eastern jewelry manufacturers are here in full force, there being a hundred or more of these "Knights of the Grip" domiciled at the Palmer House. They are all apparently in good spirits and are a jovial lot, but to a casual observer their visit seems a trifle previous. Some of the dealers, however, express their satisfaction at the early opportunity of deciding upon fall stocks, more especially those houses whose fall catalogues must soon go to press.

The Cronin case, while exciting a vast amount of interest in the minds of everybody, has an especial hold on the attention of H. S. Peck, the genial manager of the Waterbury Clock Co., who is one of that grand and representative body of men now making up the personnel of the Grand Jury, specially called to sift the great mystery. It is a matter of peculiar gratification to the people of Chicago that these jurymen are almost without exception clear-headed, irreproachable and influential business men of Mr. Peck's type.

Mr. Burchard, of Simpson, Hall Miller & Co., manages to keep as

busy in June as in November, and the order clerks and sales people are kept equally so. The new fall patterns of Simpson, Hall, Miller & Co.'s goods are beginning to open and are more attractive than ever before, which, as everybody knows, is saying considerable. Just below them are the rooms of the Gorham Mfg Co., and their western manager is not happy; he wants goods with which to supply his trade and he cannot get them; he wants, for example, at least five hundred of those sterling silver buckles which ladies are just now so partial to. His whole stock could be counted on one hand; he wants berry bowls, but there are so many orders in ahead that he cannot tell when he will get sight of any. Gorham ware seems like Elgin movements, it cannot be made fast enough.

Spaulding & Co. have instructed the directors of the American Horse Show, which has its meeting here immediately at the close of the annual exposition, to call upon them for a prize cup, to cost not less than \$500. Your observer has already been shown the design, which calls for a piece of mammoth proportions, and shows two prancing horses *en repoussé*. This will, no doubt, make the finest prize of the kind ever offered for horse competition. The *Chicago Herald* had the following to say last Sunday of Spaulding & Co.'s enterprise in Paris:

"The first collection of fac-simile duplicates of *objets d'art* now exhibited in the Universal Exposition at Paris, arrived in Chicago last week, and was taken out of bond by Spaulding & Co., the State street jewelers. Onyx vases, gold and enameled case clocks, hand painted enamels, point lace fans studded with diamonds and some terra cotta-hued bronzes are included in the shipment. The establishment of the branch house at 36 Avenue de l'Opera, Paris, enables a constant receipt of Parisian high novelties at the store here as well as the extending of appreciated courtesies to Chicagoans visiting Paris.

The Ansonia Clock Co. have now got quite settled in what are, perhaps, the finest clock warerooms in the country. Adjoining them are the spacious rooms of the Meriden Silver Plate Co., presided over by Mr. _____, and whom your observer saw setting a good example to all housewives and sales jewelers who want to keep their silverware from tarnish; camphor gum will do it every time.

Geo. Crook was met by your observer on State street yesterday accompanied by a wife. It was quite evident that this well-liked representative of J. T. Scott & Co. was on a honeymoon trip, and that for the nonce Maiden Lane jewelry was a secondary consideration. The bride is from Decorah, Iowa, where Mr. Crook has found it convenient to make rather long stays at occasional intervals for the past five or six years. Another bridegroom of the jeweler persuasion is also in town, keeping his share of a bridal suite at the Grand Pacific. It is E. P. Sunberg, of Fargo, Dakota.

Seth Thomas, of that well-known clock company, made rather a too hurried visit to Chicago within the month.

C. H. Knights left on June 16 to combine business and pleasure in a trip to Denver, Colorado; his business will probably cover three weeks. R. W. Barlow, the jolly, bald-headed and popular Illinois traveler for C. H. Knights & Co., has chosen a rather southern route to Yankeeland, and expects to shortly arrive in Vermont with his wife by the way of Washington. Will Shandrew, also one of the numerous force of Knights & Co., is utilizing his vacation in fitting up his new retail jewelry store at the corner of 39th street and Cottage Grove avenue.

Your observer has noticed the presence of the following out-of-town jewelers recently: A. W. Ford, Freeport, Ill.; J. F. Lushton, St. Louis, Mo.; Mr. Klopper, manager for J. W. Cushman, Polo, Ill.; W. H. Beck, Sioux City, Iowa; Mr. Leyson, of Leyson & Furch, Butte City, Montana; G. W. Quirk, Houghton, Mich.; C. H. Coles, Reed City, Mich.; J. W. Brill, Danville, Virginia; Ayres, of Keokuk, Iowa; Dave Hess, G. Bauman, Milwaukee, Wis.; L. S. Lavey, Lima, Ohio; Weiskopf Bros., Kenosha, Wis.; Mr. Goldschmidt, manager for Mrs. T. Kircher, Davenport, Iowa; Benjamin & Co., Dever, Col.; Walter Bauman, St. Louis.

THE CIRCULAR'S OBSERVER.



[FROM OUR SPECIAL CORRESPONDENT.]

PHILADELPHIA, JUNE 20, 1889.

Philadelphia jewelers, like their brethren in other lines of trade, have been chiefly occupied during the past three weeks in talking over the Johnstown calamity and devising measures of relief for the stricken community. The jewelers have responded nobly to the call for help, as they always do, although many firms suffered considerable losses by the death or utter bankruptcy of those who were indebted to them. David F. Conover & Co. will cancel all claims which they may hold against the estates of jewelers who perished in the flood, and they have also shown their liberality to the living by donating show cases and other necessary fixtures to enable their unfortunate customers in Johnstown and other cities to resume business. All through the State of Pennsylvania business has been crippled by the disastrous floods, and the afflicted districts will scarcely recover before fall. This has had a dampening effect on the spirits of the business community here and intensified the prevailing summer dullness. The majority think they see light ahead, however.

Henry Troemner, the well-known manufacturer of jewelers' scales, Market street, is summering in Europe, taking in the Exposition and other minor attractions.

I. Bedichimer, whose name is rapidly becoming a synonym for masonic jewels and badges, recently completed a very unique 32d degree charm for presentation to Representative Dalton E. Young, of Newport, R. I. On one side is the emblematic eagle, the eyes being of rubies and a $\frac{3}{4}$ karat diamond ornamenting the body of the bird. On the reverse appears the Maltese cross and other emblems of Templar masonry. Mr. Bedichimer is making a specialty of Mystic Shrine jewels, of which he sells a large number, both plain and ornamented.

Jacob Bennett & Son, 10 Chestnut street, manufacturers of diamond mountings, report an increasing demand for fine goods. The old craze for cheapness seems to be dying out; 18 karat is taking the place of 14 karat in their experience.

M. Zineman & Bro., manufacturing opticians, 130 South Ninth street, report a very satisfactory condition of business, which is a little unusual considering the almost universal depression of trade, since the commencement of the season. They report that their orders have been more numerous and of greater volume than ever before in their history. This attests the great popularity of the "Diamanta" spectacles and eye-glasses as manufactured by this enterprising firm. One of the principal causes of their success is that they sell their goods at unusually low prices, which they are enabled to do because they manufacture all of their goods with the exception of those that they are direct importers of. The firm's pronounced success is a good instance of what industry, push and capital can accomplish. M. Zineman, of the firm, is summering at the "Diamanta" cottage, Atlantic City.

The National Optical Co., 11th and Mifflin streets, have a new patent flexible eye-glass that seems destined to revolutionize the business. It differs from all other flexible eye-glasses in the market in that both ends of the nose piece are free, making the adjustment universal. The eye-glass rests upon the nose as light as a feather, and can be changed to any position with equal facility, whereas in other so-called flexible eye-glasses the rigidity of the spring creates a constant pressure on the nose to the great discomfort of the wearer

and the disfigurement of his features. They also have a patent spectacle that possesses the advantage of a compensating pin and screw joint, enabling the dealer to change the bow, if desired, without any filing or unnecessary trouble. All he has to do is to take out the bows that do not fit, and screw in one of the required length.

Westcott Bailey, of Westcott Bailey & Co., sailed for Europe on the *Umbria* June 8, to be absent until the latter part of August.

Jacob Muhr, of H. Muhr's Sons, has returned from Europe, where he has been for several months purchasing goods.

S. M. Fridenberg and M. S. Fridenberg will sail in a few days for Paris.

The benefit of the Retail Jewelers' Association at the Walnut street Theatre yielded a handsome sum for the organization. The association has moved its headquarters to 1,207 Chestnut street, where better accommodations could be obtained. Joseph Forsyth has resigned his position of corresponding secretary, and William H. Long has been elected to succeed him.

A Move in the Right Direction.

AT THE recent convention of the Ohio Retail Jewelers' Association at Cleveland, Ohio, S. C. Scott, of J. T. Scott & Co., New York, was present and was invited to address a few words to the meeting.

Complying with the request, Mr. Scott, after speaking of the benefits which might accrue from such an association if properly upheld, entered upon the main object of his presence—to call attention to his firm's line of cuff buttons, called the "Anti-Swear," which they have lately placed on the market.

He read from a printed circular some points of advantage which he claimed for these buttons, the final one of which was as follows: that his firm proposed to sell this line of goods only to the retail jewelry trade, in order to prevent the ruinous competition from the dry goods, millinery and other outside trades. This last clause was the one which he thought of interest to the Association. He further stated that the firm owned the patents and proposed to control the sale of these goods, and that no jobber or manufacturer would have any of them for sale; by this means they expected to prevent these goods from getting into the hands of outside trades, who have done so much to cut the profits and injure the business in most all lines of jewelry that jewelers handle.

Mr. Scott then read several endorsements from some of their customers who have handled the "Anti-Swear," in order to show what favor this line has met with since its introduction. In conclusion, he stated that he was not there for the purpose of soliciting any orders, but merely to bring this matter to their attention, as he thought his firm's method of selling these goods was worthy of their consideration, and that they would be willing to give the "Anti-Swear" cuff buttons their endorsement and recommendation, which was all he asked.

The convention then passed the following endorsement:

MESSRS. J. T. SCOTT & CO.,

New York:

DEAR SIRS:—The convention endorsed the business method of your firm in selling your Patent Anti-Swear cuff buttons only to the retail jewelry trade, and recommends the button to the members of this Association.

Very Respectfully,

ED. G. LOHMEYER, *Sec'y*,
Ohio Watchmakers' and Jewelers' Association.

PARIS GOSSIP.

[FROM OUR SPECIAL CORRESPONDENT.]

PARIS, June 10, 1889.

Parisian retailers are just now in a very excited state. They evidently thought that with the month of May, 1889, an era of easy sales and unlimited profits was likely to begin for them, and, as the result has not come up to the mark of their sanguine expectations, they seem confident that there must exist a conspiracy to ruin them. Let us examine their case and see whether they are altogether in the wrong.

It is a fact that for the past two years they found it very hard to bear against several competitions of a serious nature, described at full length in some of my letters. Desiring to combine their efforts in order to defend a position constantly menaced, they united into a league, called "The Retailing Jewelers' and Silversmiths' Society," whose members agreed not to buy anything from manufacturers known to deal with bazaars of any kind, or found to use means of drawing to their places the shops' habitual customers. These measures, and other ones to the same effect, seem to have had some good results. But an important question arose when the present Universal Exposition was being organized. When retailers understood that they could not be admitted as exhibitors since they were unable to prove that they manufactured anything or had any special article made exclusively for their places, they were thoughtful. If exhibitors were allowed to deliver, *stance tenante*, goods chosen out of their display, the buildings, in the Champ de Mars would soon become an enormous bazaar where passing visitors would buy anything they might fancy, thus neglecting to go for their purchases to the shops about the town. They explained their case to Mr. Berger,

Director of the Exposition, who at once consented to introduce in the regulations the following article: "Sold goods cannot be delivered before the Exhibition is over, except by special leave." But Mr. Berger soon found that if the prohibiting paragraph were to apply to all, Oriental dealers would refuse to come, which, evidently, would deprive the great Universal meeting of one of its most original features. In consequence, sun-burnt exhibitors obtained an unlimited permission to sell their gaudy articles; and, although it has been reported that some of their goods, such as bracelets, earrings, brooches, etc., are supplied by a Parisian manufacturer, the exception in favor of Mahomet and Buddha's worshippers has been generally accepted by our retailers. Everything seemed to be settled for the best, and all went on smoothly during the first week or so from the opening of the Exhibition, when suddenly it was rumored that Austrian, English, and even French exhibitors, in the jewelry lines, had been seen offering small goods to visitors, some of whom had bought and taken them. Mr. Hamel, President of the Retailing Jewelers' and Silversmiths' Society, anxious to ascertain these facts, went to the Champ de Mars, accompanied by a qualified lawyer (*huissier*), purchased a ring in the French section and saw a lady buy a brooch

in the English one. These and other similar cases were put down by the legal witness, and the following day Mr. Berger received a writ stating the above infractions. What will be done? I cannot tell. It is a pity that all this was not foreseen. It might have been prevented, for instance, by allowing some retailers to open shops in separate pavillions among the grounds, and take their chances just as well as the foreign fancy dealers. Then it would have been easier to enforce a regulation about goods on show in the various sections, through drawing the line between the exhibitors and the shop keepers, those being obliged to keep up to the end in their display articles evidently brought there to meet others in competition.

During the first fortnight in May, the centennial jewelry, consisting of enameled revolutionists' emblems, has been in high favor, chiefly in the working neighborhoods. Heedlessly or wilfully, some people made a confusion of dates, and pranced about with jewels meant to commemorate the 14th of July. Earrings made of broken chains and padlocks undone, with inscriptions all around, commemorating the fall of the Bastile; brooches representing the old prison on a Lilliputian scale; and trinkets, in the shape of seals and towers surrounding their base, were seen about, everywhere, as, according to history, was the case in the last fortnight of July, 1789. Something has just given a new impulse to this craze, namely, the opening, on the Place du Carrousel, of an exhibition of relics belonging to the eventful period which extends from the death of Louis XVI. to the accession of Napoleon the First to the throne, as emperor.

A novelty in salt cellars consists of silver wooden sabots, assembled by two, with a high wicker basket raising between, filled up with fishes or with apples. On that basket stands a man or a woman in Norman costume, having their arms a-kimbo, which allows room enough to receive a salt spoon in the shape of a shovel. It is finished off in oxidized, or in frosted silver with gilt, parts.

I have seen there a lovely fan, which was handled by Queen Marie Antoinette. It shows a

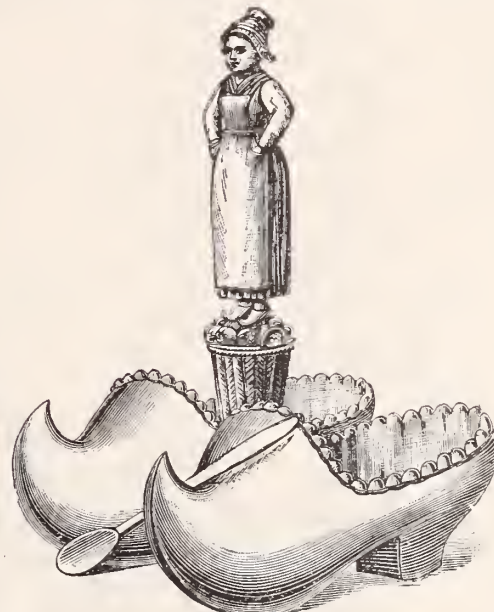
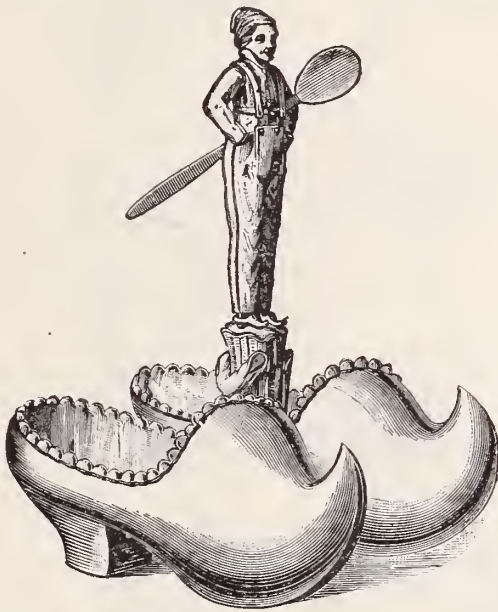

painted scene, framed with graceful garlands of fine embroidery, made of several colored silk and gold. On each side there is a pretty design formed of a spade, a rake, a basketful of flowers, and a shepherdess' hat, tastefully arranged. The sticks are of pierced tortoise shell, chiefly adorned with figures of cherubs in gold. Very curious is Marat's silver watch in the shape of a Phrygian cap, with this device: *n'obeir qu'à la Coi*. Lucile Desmoulins' wedding ring is of special interest. It is made (according to the custom of the time) of twisted gold and silver threads entwined, the former metal symbolizing the husband and the other one the wife. Hair combs to stick on men's heads would seem to have belonged to a more ancient period. Several of an elegant pattern are exhibited there. One of them has a very high top in chased gold, with an outline boldly curved. Three cameos, being portraits in the Greek style, adorn it. The center one is circled with pearls. An important collection of seals, medals and coins in gold, silver and brass; a large amount of snuff boxes and *bonbonnières*, in ivory or precious wood, with miniatures on the top; besides a countless quantity of buttons, studs and trinkets of all kinds, some of which are in the shape of the guillotine, fill up many glass cases. Visitors never fail to have a look at Lazare Carnot's sword of ceremony, partly damaskeened with gold, whose sheath is embroidered in the symmetrical and severe style of the time. It is surrounded by medals, watches, snuff boxes, etc., relics of the same, lent to the Exhibition by his grandson, our President.

JASEUR.



PLATED JEWELRY OF THE FUTURE.

GETTING READY FOR A WESTERN TRIP

OLD FASHIONED

PINS - THE WAY AROUND

MISS BATTING BROTHERS.

S. MAREBROOK & CO.
FINEST JEWELRY
10000

FABRENS & CO.

A. BILLY



[THE CIRCULAR is not responsible for the opinions or statements of contributors, but is willing to accord space to all who desire to write on subjects of interest to the jewelry trade. All communications must be accompanied by a responsible name as a guarantee of good faith. No attention will be paid to anonymous letters. Correspondence solicited.]

A FORM FOR MEMORANDUM BILLS.

New York, June 15, 1889.

To the Editor of the Jewelers' Circular:

As the editor of the oldest trade journal in the line I wish through you to call the attention of the importers, manufacturers and jobbers to the total lack of uniformity in our memorandum clause as given on memorandum bills. It was shown in the case of A. H. Smith & Co. vs. Henry Clews, that out of about 70 memorandum forms, from as many firms, only four or five were the same in phraseology, although they all aimed to preserve the title of the goods until the sale was actually consummated by the rendering of a regular bill.

While there may be a doubt in the minds of our hair-splitting friends, the lawyers, as to the terms, on memorandum or on approval, being well known and customary in our trade, there is no thought of doubt among those of us who every business day have so many calls for goods on memorandum, but there is a difference of opinion among us as to our ability to legally hold the title to our own goods after we have given them on memorandum to a customer or broker, and on this point hinges the whole matter. Let us examine it. What is a memorandum bill? Is it a contract that the owner agrees to sell the goods at the prices given? No, for it particularly reserves the right of making a regular bill of sale. If it were a contract to sell at these prices, the customer could demand the bill if he tendered the price, but there may be and occasionally are good reasons why the owner declines to sell even for cash, preferring to keep his goods. Or, if the money is not offered, the owner very often declines to make the sale on credit. In fact a memorandum bill, except for the ownership clause, might as well be made on an unprinted slip of paper, with merely descriptive numbers and prices of the goods written on it either by the customer or by the owner. The question asked of nearly all the witnesses in the Smith vs. Clews case was, what do you understand the meaning of the term, on memorandum, as given on these bills to be? The answers all showed that it was intended that the title of the goods be preserved by the owner or first party, in order to prevent the second party transferring the title to a third party, and thereby causing loss to first party, or, in short, that the goods were not sold until a bill of sale was given.

Many of us know how important it is to retain control of the title to our goods until we receive our pay for them. How common it is for some small dealer in the country to order four or five diamond pieces or very expensive watches from six, eight or ten different dealers at one time so that he can show his customer (who may be a scamp) a large assortment to select from. The small dealer is considered honest and these goods are usually sent to him by every one to whom he has written. If he is not a morally honest man the temptation to get the goods on credit legally would be very strong. If the memorandum bill is binding enough to preserve the title in the owners he must return the goods on demand or turn thief and run off with them. Again, there are many in the trade whose past records do not entitle them to credit, but to whom we are willing to sell for cash. This class of customers seldom buy goods outright. They are forced to get what they want on memorandum, show them and sell their customer what he wants, return the balance and pay for goods kept. While their trade is not always desirable, yet they sell quite a goodly amount in a year, and as they buy for cash, we do not want to stop trading with them. But as in all business matters, those who buy from them, must take the risk. The title to the goods shown must

be clear and with the seller. Who thinks of buying a lot worth \$500 or \$1,000 without searching the title? Yet men will pay a shyster dealer more than that for a diamond if they think it cheap, or if it is hinted to them that it was gotten a little irregularly. Why should the honest owner suffer in such a case? The memorandum business is an unmitigated nuisance in any light it is looked at, but it has evidently come upon us to stay. Therefore let us adopt some single universal system, with a clause in our bill, drawn by competent legal authority, which will keep our title to our goods until we part with them in a regular way. Our trade associations have good attorneys. Let them have this attended to and at once.

GEO. B.

DATES OF OLD SILVERWARE.

East Las Vegas, May 26th, 1889.

To the Editor of The Jewelers' Circular:

Below you will please find copies of marks on old silver which is in the possession of a customer. He has copied them and has added some remarks. He desires to know their age. Thinking you can give me some information in this respect, I forward them to you.

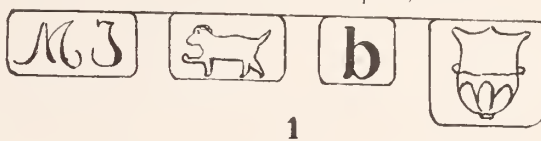

1

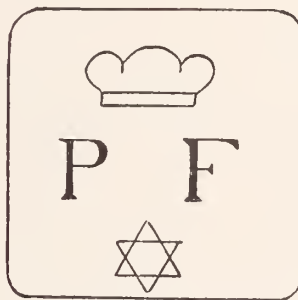

2



4

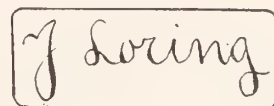

5

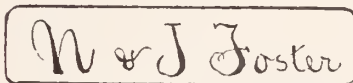

3

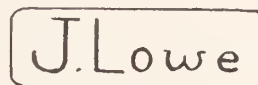

6

1. Gold-headed cane. M. T. (script); a lion passant; a small letter b; and a figure that may be a thistle head or a crown resting on a trefoil. 2. An old silver spoon from England. A crown, the capital Roman letters P. and F. and a star or mullet below. 3. Silver spoon, 60 or 80 years old. 4. Silver spoon, probably 80 or 100 years old. 5. Spoons; and smaller spoons of same set stamped with initials only. 6. Spoon, probably 60 to 80 years old. American make.

P. H. CURRAN.

Answer: 1. Hallmark, date 1777. M. F. not M. T.; lion passant; letter b, the stroke on the long portion being oblique; and a leopard's head crowned, not a thistle or trefoil.

2: We would be pleased if you would send us an impression of this mark, as we are sure there is some mistake in your diagram.

3: Date, 1789. Maker, Joseph Foster, Boston, Mass., who afterwards moved to Newburyport, same state.

4: This is no doubt the mark of David Tyler, of Boston, Mass. Date 1789.

5 and 6: We cannot find any record of these names. They are probably the names of the dealers (not makers) or purchasers. If you will closely examine the articles you will no doubt find in them some other trade mark or device by which the makers' names can be discovered.

REVIVING INTEREST IN BIRTH-STONES.

Auburn, New York, May 23, 1889.

To the Editor of the *Jewelers' Circular* :

The interest in birthstones having revived of late I have carried out an idea of my own with good success, and thought it might be of interest to others.

The enclosed card is one of a large number which I had printed and distributed very thoroughly, both by mail and presentation. The verses of course are not original with me.

The style of ring I designed is a twisted wire band, with plain neat setting, and I display a full line of them in a tray with the name of the month belonging to each. I have made arrangements with the manufacturers to give me the sizes required on short notice and the stones I keep loose, in either genuine or doublets.

I have had good returns for the outlay so far and it is but two months since I started it.

If you think well of it you can write this up to suit yourself.

Yours very truly, WM. C. CROSMAN

BACK NUMBERS TO BUY AND SELL.

New York, June 4, 1889.

To the Editor of *The Jewelers' Circular* :

I have complete files of THE CIRCULAR from 1882 to 1888, inclusive, which I would like to sell.

W. H. EINHAUS.

To the Editor of the *Jewelers' Circular* :

Vinton, Ia., June 5, 1889.

I cannot find February number of 1887. I have had last year's books bound. Would like to get missing copy.

J. A. BILLS.

South Paris, Me., May 21, 1889.

To the Editor of the *Jewelers' Circular* :

Have you a spare CIRCULAR dated 1885? If not, have you a full volume for sale? I began with Vol. 1, No. 1, and received it until the end of Vol. 14. On account of failing health, I neglected to renew, and now regret it, as I am again reading Dr. Bucklin's optical papers. I am a subscriber now.

S. RICHARDS.

KIND WORDS.

To the jeweler, a household necessity.

C. F. GREENWOOD & BRO., Norfolk, Va.

I don't want to lose a single copy.

J. G. LAWRENCE, Greenville, Tenn.

Pine Bluff, Ark., April 9, 1889.

To the Editor of the *Jewelers' Circular* :

Have secured all the missing back numbers, so I have THE CIRCULAR complete from January, 1875, to date, and intend having them bound.

SIDNEY SMITH.

Philadelphia, April 12, 1889.

To the Editor of the *Jewelers' Circular* :

Please find enclosed postal note for my subscription. I am always pleased to see it come and always find it interesting.

ROBERT H. BOTTOMLEY

Aurora Ontario, April 15, 1889.

To the Editor of the *Jewelers' Circular* :

I would not like to miss it for double the amount.

W. J. DUNN

Copyrighted 1888 by Charles A. Bucklin.

Mechanical Ocular Defects.

Their Nature, Cause, Correction and Relations to Functional Nervous Diseases.

EDITED BY C. A. BUCKLIN, A. M., M. D., NEW YORK.

[The aim of the author is to produce a clear and thoroughly practical course of instruction on the subject of "mechanical ocular defects," which is entirely void of useless technicalities and within the easy comprehension of every thinking student, without his having had any previous technical or mathematical education.]

LENSES.

The Qualitative and Quantitative Analysis of Lenses.



THE QUICKEST method of determining the nature of any lens we wish to examine is to observe the effect produced on distant objects observed through it, when the lens is held just within its focal distance from the eye and it is moved in various directions.

Prisms.—A prism when rotated causes any distant line which crosses its base at right angles to break, and the portion of the line seen through the prism becomes displaced to one side, but always remains in a position parallel to those portions of the line which are observed outside of the margins of the prism; thus if a vertical line be observed which passes squarely through the base of a prism when it is rotated, the relative positions of that part of the line which is seen through the prism and that part of the line which is seen above and below the prism will be thus—



A B represents that part of line seen above and below the prism. *C D* represents that part of the line seen through the prism. If the prism be *simple* its strength may be determined by an adjustable triangle which registers in degrees the angle at which it is set. The strength may also be determined by placing a prism with the base in exactly the opposite direction of sufficient strength to entirely neutralize all tendency to displacement when the prisms are rotated; in this case the prism used having a known value, the prism tested must be of the same value.

This method will also answer where the prism is in combination with one or two other lenses. The other lenses being perfectly neutralized the prism may then be neutralized. The adjustable triangle is perfectly useless when the prism is in combination with other lenses, simply because the surfaces of the prisms are covered with lenses which prevent the triangle from being applied to the prismatic surfaces.

Convex lenses are analyzed in a variety of ways. *First*—The distance at which they will focus parallel rays of light measured in inches gives the number of the lens. To obtain parallel rays of light its source must be at a greater distance than twenty feet. Sunlight is most frequently used. *Second*—They are measured by a variety of instruments called foco-meters; the foco-meter designed by the author is the simplest and most perfect of this class of instruments. The principle involved in these instruments is the measurement of the effect which the introduction of any convex lens produces upon rays of light which are already sufficiently convergent to make the instrument very short, convenient and portable.

A convex lens, No. 60, is measured within an instrument ten inches long.

Third—They are measured by a concave lens of known value which will exactly neutralize the apparent motion of objects in the opposite direction when they are observed through a convex lens which is slowly skaken. The distance between the eye and any convex lens examined must be less than the focal distance of the lens, otherwise the action of the lens is reversed.

Concave lenses. They are measured as follows: *First*—By a foco-

meter which registers the decreasing effect which they produce on a strongly convex lens system which is contained in the instrument.

Second—They are measured by the convex lens of known value, which exactly neutralizes the apparent motion given to objects observed through a concave lens in the direction in which the lens is moved or shaken.

Simple cylindrical lenses. They have a line of no shake this represents the axis of the lens.

The measurement of weak cylinders is possible by a foco-meter, but not as practical as the measurement of spherical lenses. The neutralization of cylindrical lenses with other cylindrical lenses of known value gives results which are positively accurate.

Convex cylinders are measured by a concave cylinder of known value which entirely neutralizes the apparent movement of objects in the opposite direction when the lens is shaken at right angles to its axis. Great care is necessary in testing cylindrical lens to determine whether the two axes of the cylinders exactly correspond or not. Two cylinders which neutralize with corresponding axes will not neutralize if there is an almost immeasurable discrepancy in the parallelism of their axes. The axes of the cylinders can instantly be placed in a corresponding position by first placing them approximately in this position, then while looking through both lenses at distant vertical or horizontal lines as the corner or cornice of a building, rotate one lens on the other till these lines are perfectly continuous and straight. The axes of the lenses will then exactly correspond if the lenses are of the same power the apparent motion of distant objects observed through them when shaken will have entirely disappeared, and the number of the concave cylinder used will be the number of the convex cylinder tested.

Concave cylinders have a line of no shake which represents their axes. A convex cylinder of equal power applied with its axis in a corresponding position will neutralize the lens.

Compound convex cylinders when shaken cause an apparent motion in opposite direction of distant objects observed through them. The motion is more marked in one direction than in the opposite direction. The line in which the apparent motion is least will be found to represent the axis of the stronger cylinder or the cylindrical lens in the combination. As there is no difference in the effect produced by a compound convex cylinder formed of two cylinders of unequal powers, and one formed of a spherical convex lens joined to a convex cylinder, we will analyze all *compound* or *crossed* cylindrical lenses as if they were sphero cylinders. Neutralize in the line of the least apparent motion with a spherical lens; this being completed a simple cylinder alone is left in the combination. Hold firmly together in one hand the lens examined and the sphere selected. Take in the other hand a concave cylinder, carefully adjusting one upon the other by rotating until all distant objects appear square. By trial select a cylinder of the necessary power to neutralize the motion caused by the cylinder in the combination. The two lenses used in the neutralization of the examined lens will represent the numbers of the lenses in the combination. The examined lens will have opposite values from the neutralizing lenses.

Compound concave cylinders are analyzed in like manner only with lenses of reversed values. The line of least shake is neutralized by a convex sphere, and the cylinder is then neutralized as above described with a convex cylinder.

Mixed and cross cylinders are analyzed in a like simple manner. These lenses give in one direction an apparent motion to distant objects observed through them which is in the opposite direction, while in the reverse movement of the lens objects appear to move in the same direction.

The line of least motion is neutralized with a spherical lens, while the remaining motion in the line of the greatest apparent motion is neutralized by a cylinder which is always of an opposite value from the spherical lens used in neutralizing the line of the least apparent motion. These rules will be criticised by many. They are not only practically and absolutely true, but the most learned mathematicians of

the world pronounce the mathematical formulæ given in support of their correctness as being beyond criticism.

It has frequently been asked by students why do all convex lenses when shaken give to distant objects an apparent motion in the opposite direction, while concave lenses give to objects under the same circumstance an apparent motion in the same direction the lens is moved. We judge of the position of an object by the direction of the light which comes from the object as it enters our eye. When the distance between a convex lens and the eye is considerable less than the focal distance of the lens and we observe a distant object through its center, we receive convergent rays of light; if the lens is moved down we receive light through those portions entirely above the center of the lens; this light will come from above downward, consequently the object will appear to move upward more and more as the line of vision falls further above the center of the lens. When the lens is moved *upward* so that the line of vision comes below the center the eye receives rays of light coming from below; consequently the object appears to move downward.

We change rapidly by the lens the direction of the light which comes to us from a stationary object; this gives to the object an apparent motion in the opposite direction. In concave lenses this is reversed. When the line of vision passes from the center of the lens upward by moving the lens down, the eye encounters rays of light coming from below; consequently the motion of the lens and the apparent motion of the object is in the same direction.

At the exact focus of a convex lens there is no motion, and beyond the focal distance of the lens the light crosses and reverses the apparent motion of distant objects produced by the movement of the lens, thus producing divergent rays of light similar to those which come through concave lenses. These same peculiarities, which are true of concave and convex lenses in all meridians, are also true of concave and convex cylinders in the meridian at right angles to their axes.

We will take up the subject of setting and framing lenses in our next.

Chas. P. St. John, a former student at the school of optics, perished in the Johnstown disaster. I am informed by E. H. Hopkins, of Penn Yan, N. Y., by whom St. John was formerly employed, that he was very prosperous in his optical work.

The school of optics will close July 1 for the season. The classes will commence forming for the coming season on September 10. In answer to many enquiries regarding the advantages claimed for this school over other institutions teaching the same subject, I would say that no comparison can be drawn. The method of teaching is entirely different. The number in each class is limited for the purpose of giving individual object instruction to each student.

I do not hesitate to say that the success which students have had in gaining a clear knowledge of optics in a short space of time has been remarkable.

The financial success of the majority of the students who have been taught by this method is a fair demonstration of its superiority over all others.

The large optical houses of the country who do prescription work for the optical trade are all thoroughly convinced that the financial success of students taught by this method has been quite general.

TO REMOVE INK STAINS.—For the removal of ink stains from the skin, oxalic acid is probably the simplest and cheapest agent for removing stains of iron ink. A mixture of equal parts oxalic and citric acid is still better, as it seems to have more rapid solvent action. Nigrosene ink is best removed by friction with a nail brush and plenty of water and soap. Eosene Ink soon yields to ammonia and friction. Violet aniline ink is readily removed by washing with a mixture of alcohol and acetic acid.

Electricity and Magnetism,*

AS AFFECTING THE PERFORMANCE OF WATCHES.

A brief statement of the general principles of electricity and magnetism with a review of the various ways in which they can injuriously affect the performance of watches, and of the different methods employed for preventing or remedying such effects.

BY "EXCELSIOR."

Continued from page 62, June, 1889.

Magnetic summary. We may therefore understand from what precedes that every "magnet" fills the surrounding space with magnetism in proportion to its strength; that magnetic bodies in a magnetic field are traversed by its lines of force and become magnetized—temporarily, if they are of soft iron, permanently, if of tempered steel; that all magnets, whether permanent or temporary, if brought close together will act upon each other by either attraction or repulsion, according to the law before quoted. It will now be easy to see that the statements made in my first article are strictly correct, and why they are so. It only remains to consider the ways in which we may avoid or remedy the injurious effects of magnetism upon watches. These come under the heads of

Remedies, protections and preventatives. There are methods and means for preventing watches from being magnetized, for remedying the evil after they have become affected, and for protecting the unmagnetized watch from magnetism.

1. Remedies. We will first consider the remedies or methods of demagnetizing watches which have unfortunately become affected. The cheapest way, and good enough to practice on a "turnip," is that followed by many employees around electric light stations. Hang the watch by the pendant at the end of a stiff cord, twist the cord up tightly, then, holding the upper end of the cord in one hand, let the watch hang near the pole piece of a powerful dynamo. Hold it still with the other hand for a moment to let the magnetism get "soaked in," then "let her spin," and as the string gradually untwists walk slowly away, removing the whirling watch further and further from the source of magnetism. Repeat the dose whenever exposed to the disease.

Demagnetizing machines are now employed to do the work of whirling the watch, which can be kept up as long, and the magnetism weakened as slowly and gradually, as may be desired. They act on the same general principle as before described, but do the work with thoroughness and certainty. The idea is to first magnetize every part of the watch thoroughly, with their north and south poles all in the same directions. This wipes out all previous polarities existing in any of the pieces, and gives them all a new and uniform polarity, *i. e.*, magnetizes them all in the same way. The watch is then reversed before the magnet, whose strength acting on the watch is also reduced a little (by increasing the distance between it and the watch or in some other way), and every part of the watch is then magnetized in the reverse way. The previous magnetism is blotted out, and the ends which before were of north polarity are now south, and *vice versa*.

This alone would have been nothing gained, for every piece is still thoroughly magnetized, all having their north and south poles alike in direction, as before. But now the magnetism is not quite so strong as it was before. The next reversal of position blots out this magnetism and gives all the pieces reversed polarities, and again the magnetism is a little weaker; and so on.

The object of the reversing is to remove the existing magnetic state, and substitute therefor another which is a little weaker. This process of weakening and virtually removing the magnetism goes on until the magnetizing influence becomes so weak as to have practically no effect on the watch, which is then found to be practically free from magnetism of any sort in any of its parts.

In the Maxim machine, which, I believe, was the first ever used in

practical work, the watch is constantly being turned in every position before the magnet, and is, at the same time, slowly removed from it by means of a screw. In other machines the polarity of the magnet itself is constantly being reversed, and the current which energizes the magnet is weakened by increasing the resistance through which it flows, thus weakening the magnet and its action on the watch; or the watch is slowly removed from the magnet by hand. Another way proposed is to first place the watch in the most powerful part of the magnetic field, then gradually move it to the "neutral point," which is presumably the position where both poles of the magnet act simultaneously and equally upon the watch, which is then not magnetized either way, *i. e.*, not at all. I have no knowledge of the practical working of this last method, but the others are well known to be efficacious if properly carried out.

2. Protections. After the watch has been freed from magnetism, it must obviously be protected in some way from being again acted upon, inasmuch as it is liable to be exposed at any time. This protection is afforded by surrounding it with magnetic metal, which shields it from magnetism, not by stopping it, but by guiding it *around* the watch instead of letting it pass to and through it.

Fig. 17 will explain the principle. *N* and *S* are the poles of a horseshoe magnet. *W* represents a watch movement, surrounded by

FIG. 17.

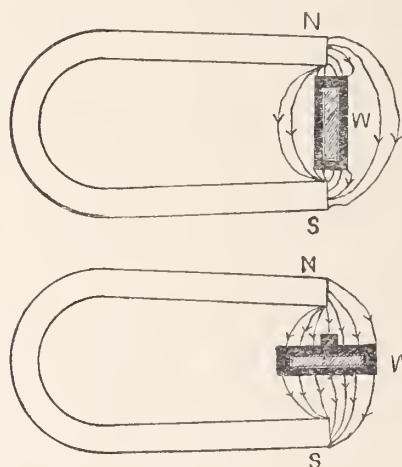

FIG. 18.

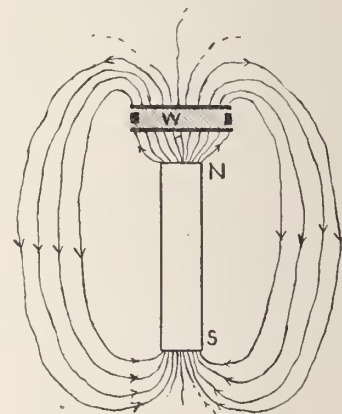

FIG. 19.

a box or envelope of soft iron, represented by the heavy black lines around it. The magnetic lines of force proceeding from *N* to *S* would naturally pass through the movement and magnetize every part of it. But before reaching it they meet the soft iron of the box, which is an almost perfect magnetic conductor—or, more properly speaking, which has almost no magnetic resistance. The lines of force take the easiest path, which is through the iron, as far as it goes. On reaching the further point of the iron they leave it, and complete the remainder of their circuit through air to the pole *S* of the magnet. It will thus be seen that the iron box does not stop the magnetism, it merely guides or directs its course, and diverts it from a path of comparatively high magnetic resistance through the movement to another of low resistance, which latter is so arranged as to conduct it around the movement instead of going through it. Such a box is, therefore, in effect a true

Magnetic shield. Its efficacy depends upon its containing enough iron to afford a free passage for the lines of force. Iron will readily conduct magnetism up to a certain amount, when it is said to be "saturated." Just as if you were pouring water into the open mouth of a pipe: if you pour more water into the pipe than it can readily carry off, the surplus will, of course, run down on the outside. So if there is not enough metal to freely conduct all the magnetism to which it is exposed, more or less of it will seek other courses through the magnetic metal in the movement. Even the thinnest shield is undoubtedly capable of protecting the movement from the magnetism of the earth and of most other influences to which it would ordinarily be exposed, but in order to be a perfect protection, the thickness of

the iron must be increased in proportion to the strength of the magnetic influences which it is required to withstand.

But pieces of magnetic metal projecting outside of the shield are weak points, because they are obviously protected by the shield only partially, if at all. For instance, if the pendant of a stem-winder be turned towards pole *N*, some of the magnetic lines of force would take their course through it, because it would be nearer the pole than the shield was. Again, if the shield be presented to the pole flatwise, as in fig. 18, the protection is much less than in fig. 17, for the lines of force, instead of following the long and roundabout course through the walls of the shield, may some of them take the shorter and more direct path straight through the magnetic parts of the movement. In such a position the center post is especially exposed and liable to become the passageway for more or less magnetism directly into and through the movement, as seen in fig. 18.

This danger is greater, if the edge or rim of the shield is not in contact with its front and rear sides, as represented in fig. 19, where an air space or break in the path of the lines of force is seen. (The lines of force passing through this break are not drawn). This danger increases with the increase of distance between the two adjacent portions of the iron, as it makes the magnetic resistance by way of the shield nearer equal to that through the steel parts of the movement. In order to be really efficacious, the parts of the shield should be in contact, as in fig. 17, or very near to it, with an amount of metal proportional to the magnetic force acting upon it.

Magnetic Pockets.—As there is a limit to this increase of iron around the movement, it is better, where the watch is liable to be exposed to very powerful magnets, to also inclose it in a magnetic "pocket," *i. e.*, an iron box into which the watch case can be placed. Any desired amount of metal can be used in such a pocket, as its size, shape and beauty of proportions need not be considered, while in a watch case those points could not be disregarded. Then, by using reasonable care when consulting the timepiece, to avoid taking it out of the magnetic pocket except when the magnetic influences around it were such as the shield alone could safely resist, the protection would be practically sufficient for all purposes.

Anti-magnetic watches are those in which the balances, hairsprings, ruby rollers, and lever forks and pallets are made of steel and strongly magnetized. It is hardly necessary to say that any watch in which those parts are powerfully attracted by every piece of iron or steel near them, is certainly not to be commended as a first-class timekeeper. It may be magnetized in a particular way, which is preferable to some other way—but that is merely a choice between evils. The fact that a magnetized watch gives good results in an observatory test, indicates nothing, for the reason that the metallic surroundings are uniform there during the test. But let the same watch be exposed to the constantly changing conditions and arrangements of metallic objects around it met with in actual use, and it might prove to be practically worthless for fine timekeeping, although it might still be far superior to one magnetized "just as it happened."

The best possible way is to magnetize the whole rim of the balance *one way*, say North, and the center of the balance, the staff, and the roller table, all South; and it is preferable to magnetize these parts after they are put together. That is easily and quickly done by means of a special apparatus, in which the balance rim is in contact with one pole of the magnet and the central parts with the other pole, during the operation. It is beneficial to turn the balance around and so rub the parts over the poles while magnetizing, as their magnetism will be stronger. The staff and table roller, being hard, retain their magnetism longer, and tend to prolong that of the balance. I also proposed to harden the central portion of the center bar for the same purpose, by first suddenly heating it red hot by electricity, then clamping it rigidly between two heavy cold blocks, to harden it.

Then the inner or notch end of the lever fork should be South. The hairspring, the lever pallets, pallet arbor and escape wheel pinion (or such of them as are to be magnetized) should be magnetized *the same* as that part of the balance which is nearest to each one, in the watch. In this way we cause *repulsion* between the adjacent parts of the escapement, which is less powerful than attraction, and we also cause any external attraction to act upon the balance in a manner *alike all around the rim*. It is obvious that we do not prevent magnetic attraction and repulsion from acting upon the parts

in the escapement, but only render such action more uniform and less objectionable, and we prevent it from accidentally becoming magnetized in a more injurious way, until it is exposed to external magnetism strong enough to overcome its own.

It will, perhaps, not be out of place to say that this process and apparatus, from beginning to end, are my inventions. The same thing may be said of all the other anti-magnetic devices described in these articles, and the second class of demagnetizing apparatus described.

RECENT PATENTS.

The following list of patents is compiled from the records of the United States Patent Office, and specially reported to THE JEWELERS' CIRCULAR.

Issue of May 28, 1889.

- 403,943.—SAFETY ATTACHMENT FOR WATCHES.** CHARLES G. KREBAUM, Havana, Ill. Filed Aug. 2, 1888. Serial No. 281,738. (No model.) A watch protector, constructed of rubber or similar material and adapted to fit around the stem of a watch; has a concave or hollowed top to provide a rim which has outward-projecting guards to engage the side of the pocket.
- 404,092.—ORNAMENTAL RING FOR JEWELRY.** GEORGE H. KNIGHT, Providence, R. I., assignor to William R. Lane & Co., same place. Filed Oct. 27, 1888. Serial No. 289,330. (No model.) A jointless ring having plated inner and outer surfaces, and having the base metal at the edge of the ring concealed by means of a flange which is beveled at its end, and turned so that the plating of the flange will be carried over the edge of the ring and over the base metal at the end of the flange, and be made to abut edge to edge with the plating of the opposite surface.
- 404,093.—ORNAMENTAL RING FOR JEWELRY.** GEORGE H. KNIGHT, Providence, R. I., Assignor to William R. Lane & Co., same place. Filed Oct. 27, 1888. Serial No. 289,331. (No model.) A jointless ring having inner and outer surfaces and having angular thickened edges formed by an outwardly turned thinned portion or flange, which carries the inner plating outwardly and back against the surface of the outer plating over the edge of the ring and conceals the base metal.
- 404,094.—ORNAMENTAL RING FOR JEWELRY.** GEORGE H. KNIGHT, Providence, R. I., assignor to William R. Lane & Co., same place. Filed Oct. 27, 1888. Serial No. 289,332. (No model.) An ornamental ring formed from a seamless plated tube and having the end portions of the tube turned backward, so that the ends thereof will abut against the surface of the tube and the exterior plated sides of the turned end portions will be in contact with each other.
- 404,099.—WATCHMAKER'S LATHE.** STEPHAN MESSERER, Newark, N. J., assignor of one-half to Jean Tack, same place. Filed June 2, 1888. Serial No. 275,805. (No model.) In this lathe is combined with front and rear headstocks thereof, the latter having an adjustable center of a hollow spindle, provided with a flange, a chuck and a draw-in spindle, screw-threaded to the chuck at its inner end, and provided at its outer extremity with a socket to receive the center, and with a suitable finger-piece.
- Design Patent No. 19,121.—THIMBLE.** JOHN F. SIMONS, Philadelphia, Pa. Application filed Feb. 15, 1889. Serial No. 300,060. Term of patent 14 years.

Issue of June 4, 1889.

- 404,506.—APLANATIC LENS.** HEINRICH L. H. SCHROEDER, 17 Althorp Road, Upper Tooting, County of Surrey, assignor to John Stuart, Clapham, County of Surrey, England. Filed March 13, 1889. Serial No. 303,139. (No model.) Patented in England April 7, 1888. No. 5,194. An aplanatic lens or objective giving a positive image, and being composed of a plano-convex lens made of high refractive power and as high or higher dispersive power, the convex surface of the lens or objective having a longer radius than the concave surface.
- 404,522.—METHOD OF MAKING RING-DIES.** FREDERIC ECAUBERT, Brooklyn, N. Y. Filed Nov. 5, 1888. Serial No. 289,972. (No model.) This method of manufacturing annular dies, in finishing up the ring of soft steel with the necessary contour, engraving or ornamentation upon the interior surface thereof, hardening the said ring, and afterward breaking the ring apart into two or more sections adapted to being placed together for use or removed from the article that is rolled or otherwise formed to shape within such ring-shaped die.
- 404,803.—TRIAL-FRAME FOR OCULISTS AND OPTICIANS.** ANDREW L. SMITH, Geneva, N. Y., assignor to the Geneva Optical Company, same place. Filed Sept. 3, 1887. Serial No. 248,674. (No model.) This trial-frame for oculists consists of the frame-work thereof and the lens-holders adjustable thereon, in combination with the central bearing-block of the frame-work having its front face circular or segmental in shape, an adjustable nose bridge-piece resting against the circular or segmental face of the central block, an oscillating shaft mounted in the central block, and a clamping screw and nut engaging with the said shaft and clamping the nose bridge-piece against the face of the central block.
- Trade Mark Patent No. 16,665.—OPTICAL GOODS OF ALL KINDS.** ANDREW J. LLOYD, Boston, Mass. Application filed April 1, 1889. Used since Sept. 8, 1888. "The representation of a lion issuant."
- Trade Mark Patent No. 16,679.—WATCH MOVEMENTS.** AMERICAN WAL-

THAM WATCH COMPANY, Waltham, Mass. Application filed April 12, 1889. Used since Jan. 1, 1888. "The letters and words 'A. W. W. Co., Riverside, Waltham,' and a circular design or frame-work enclosing them."

Trade Mark Patent No. 16,698—OPTICAL INSTRUMENTS. CHARLES F. PRENTICE, New York, N. Y. Application filed April 12, 1889. Used since November 5, 1886. "The word 'Opticist.'"

Issue of June 11, 1889.

404,906—**ELECTRIC ALARM CLOCK.** WILLIAM E. HADLOCK, Wrentham, Mass. Filed February 8, 1888. Serial No. 263,416. (No model.) An electric circuit closer and breaker for clocks, comprising two members, one carried by the clock hand and the other located in its path, and completing the circuit when the member carried by the clock hand engages the other member; these combined with a contact piece in the same circuit co-operating with one of the members, which is operated by the movement of the clock hand, whereby the circuit is broken, while the two members that originally closed it still remain in engagement.

404,910—**THIMBLE.** CHARLES HORNER, Halifax, County of York, England. Filed June 21, 1886. Serial No. 205,824. (No model.) Patented in England June 14, 1884, No. 8,954. A thimble composed of an outer casing and an inner lining, both of precious metal, in combination with a steel core interposed between the casing and lining, whereby a thimble having the appearance of the precious metal and the durability of steel is formed.

404,937—**WATCHMAKER'S TOOL.** ALBERT F. THOMPSON, Adel, Iowa. Filed August 23, 1888. Serial No. 283,547. (No model.) A tool for watchmakers, consisting of two handles pivoted together and provided beyond their connection with jaws bent upwardly, tapering toward their outer and upper ends and beveled on their adjacent side edges to form knife edges.

404,956—**FINGER RING.** LEVI L. BURDON, Providence, R. I. Filed October 4, 1885. Serial No. 287,160. (No model.) A composite ring having a roundabout seamless exterior surface of suitable metal, such as alloyed gold, and an interior or filling portion of inferior metal or composition of metals united to the exterior portion, and having the ends of the ring united.

404,997—**CLOCK PENDULUM.** JOSEPH WERNER, Dresden, Saxony, Germany, assignor to Arthur Dzondi, same place. Filed October 10, 1888. Serial No. 287,778. (No model.) Patented in Germany February 15, 1888, No. 44,446. In this pendulum is combined with the vertically adjustable carrier anchor spindle and suspension springs, suspending the spindle from the carrier of an adjusting lever suspended at its upper end from the anchor spindle, the pendulum pivotally suspended from the lever between the ends of the latter, and also connected with the latter at the lower end thereof, and an adjusting screw applied at the last-mentioned connection for the lateral adjustment of the pendulum.

405,004—**KEY FOR TIMEPIECES.** MARTIN BOCK, Hazleton, Pa. Filed November 16, 1888. Serial No. 291,045. (No model.) A key for timepieces consisting of a freely rotating pipe to engage the post or arbor of the mainspring, combined with a friction clutch by which the rotation of the pipe may be regulated so as to let down the spring gradually and easily without danger of breaking and without accident or injury to the workman, and a detent or locking device for such pipe, whereby its rotation may be arrested as desired.

405,089—**ELECTRIC SELF-WINDING CLOCK.** JAMES H. GERRY, Brooklyn, assignor to the Self-Winding Clock Company, New York, N. Y. Filed March 21, 1889. Serial No. 304,111. (No model.) In this mechanism is combined the clock train having a mainspring for driving the same, an electro-magnet having curved pole pieces, with armature having its face curved to correspond with said pole pieces, a sector, springs insulated from each other and from the train and having the circuit-closing points, a wheel upon the main shaft of the clock train, a lever engaging therewith, and pins which control the positions of the springs.

405,157—**MOUNTING FOR EAR RINGS.** VALENTINE GENTNER, JR., Buffalo, N. Y. Filed September 24, 1888. Serial No. 286,260. (No model.) An ear mount provided with a curved slot, across which is secured a spherical bearing surface, and which has a setting having a loop adapted to rest upon the spherical bearing surface.

405,206—**ELECTRIC ALARM CLOCK.** BENJAMIN DUBINSKY, St. Louis, Mo., assignor to one-half to Charles P. Budd, same place. Filed March 18, 1889. Serial No. 303,693. (No model.) This clock, has its graduation, combined with an encircling frame having its graduation a series of adjustable pins, an arm moving with the shaft and an electric alarm.

Issue of June 18, 1889.

405,258—**CLOCK MOVEMENT HOLDER.** JOHN HARWOOD, Somerville, Mass. Filed March 16, 1889. Serial No. 303,609. (No model.) This device for holding clock movements consists, essentially, of a standard threaded at its upper end and supported by a pedestal, an externally threaded tube and set screw, a tubular thumb piece provided with the annular groove and spring, a cross head and a frame supported by the thumb piece.

405,394—**ATTACHMENT FOR CLOCKS.** EDWARD T. CHASE, Philadelphia, Pa. Filed November 9, 1888. Serial No. 290,351. (No model.) The combination, with the gong bracket and bottom of a striking or chiming clock, of a bracket having a threaded boss, a rod, one end of which is threaded and screwed into the boss, and a support resting upon the bottom of the clock and against which the lower end of the rod bears.

405,437—**SPEED INDICATOR.** ALBERT R. SHERMAN, Pawtucket, R. I. Filed December 26, 1888. Serial No. 294,701. (No model.) The combination, with a time clock having the usual graduated face and moving index hands, of an annular dial surrounding the clock dial, a toothed disk or wheel arranged behind the clock and having a cuff or flange extending around the clock and adjustably connected to the annular dial, and a gearing connecting the toothed disk to the engine.

405,529—**BUTTON.** CHARLES A. BRYANT, Wakefield, Mass. Filed April 1, 1889. Serial No. 305,502. (No model.) A button composed of a front and a back piece, the latter having an opening to allow the entrance of the stud or back piece, which has an annular groove in its shank to engage with two springs in the back that are integral with the body of said back.

Fashions in Jewelry

A Lady's Rambles Among the Jewelers.

THE past month has developed nothing radically new in jewelry.

* * * * *

WHILE there is an absence of startling innovations, there are numerous useful and decorative objects in both jewelry and silverware which present new features.

* * * * *

CARVED and chased work in white finish afford some of the most artistic objects made in silver at the present time, and yet the oxidized finish holds its own and promises to make a lively competition with white and bright finish again.

* * * * *

SOONER or later, as a rule, the fashionable world is influenced by what the French people have and wear. Just now oxidized silver is to the front in gay Paris.

* * * * *

THE miniature brooch, which has already found great favor, promises to be one of the leading styles in neck pins during the coming autumn and winter.

* * * * *

THE miniature paintings on ivory, employed in brooches, are set in two ways, viz., the French border, which is carved and laid over the edge of the painting, and the American border, either carved or chased, and placed below the painting.

* * * * *

ROUND brooches are exceedingly popular, although oblong and irregular forms find patrons.

* * * * *

ALL gold jewelry is more fashionable than previous in some years.

* * * * *

INDICATIONS point to the revival of all gold necklace pendants, pendants of which the beauty lies in artistic shape and fine workmanship.

* * * * *

GOLD beads appear to have come to stay. These form an attractive necklace, and are worn in from one to seven strands. The preferred style calls for small to medium-sized beads.

* * * * *

AN ATTRACTIVE necklace is formed of three strands of graduated gold beads, the largest size finding a place at the front of the necklace.

* * * * *

DECORATIVE hair pins of gold and silver remain in fashion.

These are made in coil and knot patterns, also in carved work.



TORTOISE shell side combs, in small to medium sizes and with ornamental tops, are in increased demand. Numbered with new combs are those with gold tops surmounted with little gold balls. Gold wire-work tops are also attractive.



ELEGANT and costly side combs have their gold tops studded with gems. A pleasing style seen consisted of a row of pearls surmounted by diamonds and pearls of larger size, alternating in a second row.



ALL gold scarf pins are finding many patrons. An approved style is a flower or other design in carved work.



NECK ornaments being in fashion, naturally enough has stimulated again the desire for ribbon pins. A pleasing style of ribbon pin is the miniature round brooch in diminutive pattern.



CHASED work in silver, applied upon ivory by hand, furnishes some of the most artistic toilet articles in the market. Where the exposed ivory is carved, the artistic effect is correspondingly increased.



CARVED or chased gold jewelry set with small brilliants and pearls represents a class of personal adornments everywhere popular, meeting, as it does, the demand for decorative effect at a comparatively small cost.



A NEW watch attracting attention is enclosed in a square case and is designed to be worn on a chatelaine.



ALREADY various objects, such as pins, bangles and barometers, are out in both gold and silver fac-similes of the Eiffel tower.



THE Eiffel bangle consists of a circlet of gold rope tied on top in a true lover's knot, from which swings a pendant simulating the Eiffel Tower.



CANE heads and umbrella and parasol handles are a study at the present time. The solid looking silver heads and handles, running, in some instances, a third the length of the stick and made by the deposit process, appear to be as fashionable this season as last.



NEWER than the solid handles are those of ivory with applied silver.



A SOMEWHAT costly but beautiful handle is a silver one exposing ivory carved in Japanese style.

A NOVELTY attracting attention in various quarters is a stout but æsthetic corkscrew, with buckhorn handle and profuse ornamentation.



DRINKING flasks now come in boxing glove pattern. These, it is said by those who ought to know best, are shaped just right to fit into an inside pocket.



A DRINKING flask, on one side of which appears in chased work a fine specimen of pouter pigeon, is a remarkable piece of handiwork.



THE miniature paintings on ivory, which are for the most part imported, depict, as a rule, historic subjects, being copies of old paintings. Of late the head of Martha Washington has figured along with those of old time court beauties



As THE tennis season is at hand and all sorts of picturesque outing and negligé garments are consequently en règle, the new scarf holder, previously described, is again brought to notice. This article, while severely practical, has nevertheless been made so as to serve also as an ornament. The gold holders show a variety of finish, including the Roman, bright and chased. Others are ornamented with gems.



GEORGE WASHINGTON'S dress sword has been simulated of late in both gold and silver, these fac-similes serving the various purposes of hair pins and scarf pins.



TO THOSE who are sentimentally inclined is dedicated what may safely be termed the lover's brooch. This consists of two gold bars between which swing two gold hearts, united by a chain and padlock.



A UNIQUE gold bracelet is one ornamented with a jeweled daisy in the heart of which appears a watch dial.



A NEWCOMER in ink bottles is of rock crystal finished off with a silver top, containing a compartment for holding letter stamps.



DECIDEDLY new in water pitchers is a cut glass model mounted in silver, and having an inner compartment or "well" in the center for holding the ice.



ARTICLES commending themselves to the lovers of dogs, include a walking stick dog lead and a variety of whistle calls. The inside of the stick of the first mentioned article is ingeniously arranged with a short chain and swivel, which, on occasion, can be drawn out, forming a convenient dog lead. When not in use swivel and chain are entirely concealed, and the stick presents the appearance of an ordinary walking cane.



THE combination whistle and match box in silver is likely to

attract attention. This, as the name indicates, serves the two-fold purpose of a call and deposit for matches.

* * *

* * *

* * *

JUST why women like to wear an indefinite number of bangles, each one varying in pattern and finish, nobody pretends to understand. But the fashion continues to exist, much to the delight of the manufacturers of said bangles.

* * *

* * *

* * *

IN FANCY jewelry occur many such realistic pieces as a brooch simulating in brilliants two bits joined in the center by a horseshoe. Another device is that of two gold crops crossed in the center and joined by a horseshoe.

* * *

* * *

* * *

IN THE lower priced goods there is considerable demand for such matter-of-fact designs as the padlock and key, the merry thought bone, double hearts and true lover's knots and the buckle ring.

* * *

* * *

* * *

THE buckle ring is a somewhat massive all gold affair which presents the appearance of a pierced thong, secured by a hasp thrust through it.

* * *

* * *

* * *

CHATELAINE watches in gold or silver have proven popular presents for bridesmaids at recent weddings.

* * *

* * *

* * *

A PRETTY conceit likely to please the ladies is a silver sabot in which is set a plush cushion for pins.

* * *

* * *

* * *

AN ARTISTIC piece for the toilet is an ivory tray partially concealed by its applied silver decoration, and showing in the center a mound of blue velvet designed to serve the purpose of a pin cushion.

* * *

* * *

* * *

ALMOST every collection of wedding presents among fashionable folk, includes at least one punch bowl and liquor set. Many of these are composed of crystal with silver mounts. Naturally the grape figures frequently in the designs wrought upon the silver.

* * *

* * *

* * *

THE Queen chain has a competitor in a chain of delicate, light workmanship in what is familiarly known as the fancy vest style. Sometimes this chain is finished with a swivel and sometimes with a pin to fasten at the side.

WATCH pins made to wear with the short vest chain assume a variety of designs, an original one being a gold hook.

* * *

* * *

* * *

AN ATTRACTIVE outfit in way of watch and chain, is a watch with a miniature painting set in one side of the case, while a similar painting, but much smaller in size, is mounted for a watch pin.

* * *

* * *

* * *

A WATCH set in a gold bracelet and surrounded by a ring of diamonds, is one of the presents of the day to bridesmaids, where all parties concerned have little regard for expense.

* * *

* * *

* * *

BRIGHT cut bangles are numbered with popular sorts in silver.

* * *

* * *

* * *

BOBKN pins, being easy to adjust, are conveniently used for holding the bonnet in place; consequently these are made with decorative heads in both silver and gold.

ELSIE BEE.

Window Dressing.

OBSERVATIONS IN LONDON.—WINDOW DRESSING A NEW ART—ITS VALUE.—SIMPLICITY, THE AIM.

TO MAKE special tours to "look at the shops" has long been the practice of thousands of those ladies who have not any fixed method of employing their time. "Looking at the shops" in London—and, I presume, in New York also—seems to take the place of walking "over the hill," "down to the river" or "across the fields," in our country districts. The object aimed at in all is the same—to pass pleasantly some spare time upon which no fixed claim is laid. I can only suppose that it is in just accord with that inexorable rule to the effect that there is always a supply to meet a demand, that the custom of making exclusive displays in our shop windows exists. That these displays are made purely for the information and accommodation of actual buyers I cannot believe, because experience shows that, as a rule, when a person really intends to purchase, she or he goes straight inside the establishment and then has specimens of the particular article required spread out for selection; different kinds are compared and the relative merits of each are considered before the purchase is concluded. It will be noticed that the display in the window is very rarely taken into account in the transaction. I do not say that at some earlier stage a display in the window may not have had something to do with the matter, but the majority of our West End jewelers would tell me, in reference to any particular sale I might indicate, that it would most likely have been made just the same if, on that one day, the shop window had for any reason been devoid of its attractions. As I have said, I have recently paid a visit to many of the best shops, or rather, shop windows, in some of the principal streets of London. I noticed repeated instances of persons coming along the street, or crossing it nearly opposite a shop, or stepping out of a conveyance at the door—but in each case they went directly into the shop apparently quite regardless of the elaborate display in the window. I also noticed other persons who very leisurely strolled up to the window—of course they strolled up to the shop, also—but it was very evident that the window alone was the object of their attention. They

seemed to look with pleasure at its contents, to criticize them freely to their companions, and then they strolled away again as leisurely as they arrived.

I had not any difficulty in deciding that these were "looking at the shops" and could not be said to be shopping. For the time being I joined this last-named contingent, and, as my business for that particular afternoon was "looking at the shops," I soon found myself accompanied for a considerable time from shop to shop by the same persons.

Regarding the window displays from the particular point of view I had assumed, I was reminded of the great improvement that has been effected during the last few years in window dressing. Ten or twelve years ago it would have been difficult to imagine the great development that has taken place in the art of window dressing. It certainly is an art, and one in which there is very great scope for the display of taste and originality. Remembering our jewelers', and silversmiths', and watchmakers' shops of about twenty years ago, I come to the conclusion that one-half, at least, of the present more pleasing effect is due to the great reduction in the quantity of things shown. It is only necessary to compare some of our better shops now with some of the others, to see at once that the great evil to avoid is over-crowding. The best taste in the arrangement of the windows of our principal jewelry shops is making itself felt by its simplicity. The most effective window displays are those in which goods are shown in very moderate quantities.

I think our retailers are acting wisely in consulting the taste of their friends who come only to "look at the shops." Many of those who come so to-day will some day want to purchase, and it is only natural that they will then resort as purchasers to those houses whose windows left the most pleasing impression on their minds as spectators.

It is becoming more the rule that in our better London shops goods are not displayed in excessive profusion; but there is still room for an extension of the improvement. Our fashionable houses in the silk and millinery trades employ professional window dressers—men who devote their whole attention to the artistic display of the materials and articles dealt in. There is room for great skill and considerable ingenuity—nay, I will say, for high art—in the arrangement of the articles in a jeweler's shop window. Each article should be placed so that it will attract attention; the position should be changed every day, and the articles themselves frequently alternated.

It should be remembered that the interest of the persons who come almost daily to "look at the shops" can only be maintained by something new. Every variety of taste must be catered to, and this can only be done by frequent exhibitions of fresh and attractive articles. My opinion is that these frequent changes will be found not only interesting to those who look at the windows, but also profitable to the shop keeper. If a particular suite, or ring, or pin, or bracelet, has been shown in a window for any length of time, many persons will have become accustomed to it, and when the time arrives for them to make a purchase they will have almost any pattern but the one with which they, and perhaps many of their acquaintances are so familiar. Articles seen too frequently repel rather than attract, whereas a frequent change in the character of the articles displayed and in the style of arranging them attracts persons to the window and creates a favorable impression of the superiority of the establishment. Our retail shop keepers—your store keepers—may, I think, follow with great advantage the example of our best *modistes*, who never exhibit a bonnet, or a mantle, or a dress, more than two days consecutively, and who take particular care that its position in the window shall not be the same, even for those two days. I can quite understand that a lady might go into ecstasies over a bonnet seen for the first time, but if she saw the same bonnet in the same place, and with the same surroundings, on several days in succession, her fancy would grow weaker and she would soon get to dislike what she had at first admired. Any article, whether it is a feathered hat, a tailor-made costume, a diamond pendant or a fancy stone ring, is

more likely to enhance the favorable impression it first creates if it is only seen occasionally than if it is exposed to view for many days, perhaps weeks, in succession under precisely the same circumstances. When a really good article is withdrawn after a short display in the window, "those who come to look at the shops" notice its absence, and some, who may perhaps have begun to entertain a desire to possess it, will regret they did not use the opportunity of purchasing it. They will imagine it is sold; and it is remarkable how well patronized a shop becomes whose goods go off quickly.

I have seen shops where true artistic taste in the arrangement of the articles in the window was displayed to perfection. I have also seen others, claiming to be first-class shops, where goods of equal quality were crowded together with apparently no other design than to get the largest possible number of them into the space at command. It is true I have never kept shop for the sale of jewelry, and I shall probably be told that the man who *does* keep it knows better how the window should be dressed than I do. Possibly he does from his point of view, but I wish to bring before him another and, perhaps to him, a new aspect of the same question. I have had rather extensive experience in displaying expensive jewelry, articles of vertu, valuable articles of ornament and utility, to the best advantage, and that experience has convinced me that the most artistic display can be made with a limited rather than with a superabundant number of articles.

I am sure that those shop keepers who have achieved success in the artistic arrangement of their commodities have found it a pecuniary success as well. Buyers are more likely to appreciate an article which the vendor appreciates. I have just seen a window full of good stock (there did not appear to be any inferior articles in the whole collection), but they were crowded together in the most painful confusion. The very quantity was appalling, and I grew tired in looking at them. I could not now name any one article that impressed me particularly, and yet I have no doubt there were many justly entitled to consideration and appreciation. I believe there were some silver menu stands and silver flower stands that, seen under favorable conditions, would have been more than ordinarily attractive. But they were simply lost in a chaos of valuables. They were not buried, not hidden, but shown without any art, without any taste, and consequently without any effect. I would respectfully suggest that any work of art should be treated with the respect due to the art it represents. How can a dealer expect a person of taste and judgment to desire to possess an article which he himself treats contemptuously? It is treating an article contemptuously to crowd it in with other articles that have no affinity to it. Yet this is done every day. Many windows and their contents are scrupulously clean, and the proprietors seem to be satisfied with that. I pity the assistants who keep them so—they seem to take out the stock periodically, clean the windows and the stand and, if necessary, the articles themselves, and then replace them just as they were before, probably as they will remain for months to come. The way the work is done shows it is irksome, and there is an evident sense of relief when it is finished. In proper hands, the window display of the beautiful productions that our retail jewelers now always keep in stock, is work in which honest pride should be taken. You may call this a mere sentiment if you like, you may say it is only a satisfaction arising from gratified vanity at having a better display than one's neighbor, but in these days it is worth any money to its possessor. This important work—window dressing—when no pride is taken in it, when it is pursued without ingenuity, when it excites no emulation, affords no pleasure to the man who does it, cannot excite any interest in the public, and consequently does little to improve the business of the proprietors.

It is only bare justice to the artists to whom we are so much indebted for the beautiful productions we enjoy in such profusion, that those whose business it is to display their productions even in shop windows, should cultivate some of that true artistic feeling to which such works owe their origin.

Problems in the Detached Lever Escapement.

BY DETENT.



IN ALL THE various problems we have had under consideration, we have never taken up the relation of the lever escapement to the balance spring. This has been in a great measure owing to the importance of having all parts of the escapement thoroughly understood before this question was brought on the tapis. Most workmen imagine that adjusting is a great mystery, and that the man who masters this portion of the watchmaker's art must necessarily stand at the head of the profession. I use the word profes-

sion advisedly, and I hope our horological schools will soon be in condition to bestow degrees as do schools of law and medicine.

It is well to know that a balance spring adjusted to isochronal vibrations in a duplex or chronometer watch would not possess this property if placed in a detached lever. To make this proposition better understood, suppose we were to make two movements, one of which was provided with a detached lever escapement of the most perfect construction, the other a detent or so-called chronometer escapement; the trains of each watch as far as the scape wheel being precisely alike. For these movements we made but one balance staff and balance spring. In other words, the balance staff and balance spring were interchangeable, after we changed the rollers on the staff to adapt it to the escapement of the particular movement to be experimented with. The balance and its spring were perfectly adjusted to isochronism with the lever escapement. Now, if we changed the balance with its spring to the chronometer movement we would find the general rate of the watch about the same; that is, if the weight of the rollers were alike; but the spring, which was perfectly isochronal with the lever escapement, was badly out with the chronometer escapement. What does this tell us? Simply that the escapement is a great factor in isochronal adjustments. This influence exists not in an abstract sense, because one is a lever escapement and the other a chronometer escapement, and that if the balance had been changed to another lever escapement that was adapted to receive it, it would have been perfectly isochronal, as it was with the first movement. One fault in watch manufacture we must strive to remedy lies in seeking to separate the watch constructor from the watch adjuster, because the adjuster will constantly be trying to remedy faults in construction by making his adjustments imperfectly compensate for these imperfections. Whereas if the maker did the adjusting also he would be able to locate the fault and remedy it instead of trying to make one error correct another, which is much like the doctrine of doing evil that good may come of it. Much of the adjusting, especially of the more delicate methods relating to position, consists of remedying downright mechanical defects. But if we are going to take up the problem of adjusting as related to the detached lever escapement let us commence at the beginning.

Adjusting is divided into three departments, viz., heat and cold, isochronism and position. To take them up in order we must first consider adjusting to heat and cold. Most people fancy there is but little in this; that all one has to do to effect this compensation is to take a balance which has its rim composed of composite metals (brass and steel) and cut it at a certain place, run some screws into the rim, poise it and it is complete. Others carry the idea a little farther and think the segments should be provided with extra holes so that the screws can be shifted to different posi-

tions along the segments until the proper compensation is effected. Although this is true, still it is not even the A B C of heat and cold adjustment. The trade has experimented a great many years with the compensating balance, but still the problem is far from solved. We may venture to lay down a few rules for construction, deduced from experience. A compensation balance should have its compensating segments composed of brass and steel in the proportion of three to two, that is, three-fifths of brass and two-fifths of steel, and the thickness of the segments one thirty-second part of the diameter of balance, not, of course, centering the screws. These proportions are not absolute but approximate, and about the aggregate result of actual measurements of fine balances of several hundred watches from the best makers, English and Swiss. The depth of the rim should be three times the width. It is important that the relative thicknesses of the composite metals should be preserved throughout the entire extent of the two segments. This, of course, is the immediate province of the balance maker, but the workman who finishes should, on receiving the balance, be competent to judge whether or not it is adapted to his purpose.

In making compensation balances the steel is usually hardened by quenching and tempering, and the brass hardened subsequently by hammering. Recently some fine balances have been made by the electro-deposit process. This process seems particularly adapted for the production of balances for non-magnetic watches. An alloy of gold and platinum has an expansion ratio about the same as that of steel. It hardens in the rolls to a fine spring temper, and then can be wrought into shape by lathes and die press. This portion of the balance corresponds to the steel part of a compensation balance. The portion to be added which corresponds to the brass or outer portion of the rim is of silver deposited by galvanic action, and the current so regulated that the deposit is as hard and elastic as best rolled or hammered silver. This process ensures a very accurate balance, as the inner part of the rim of the balance which is of gold and platinum alloy is of exactly the same thickness throughout the entire circuit, and consequently if after the silver deposit is made, the rim is turned off so all parts are alike in thickness the relative proportions of the composite metals must be preserved throughout. The first cost of the material for such a balance for a watch would not exceed forty cents, a very inconsiderable sum when a high grade movement is in question.

To resume the question of compensation balances of ordinary construction. After the outer brass rim is hardened by hammering, the segments are cut near the arms. As soon as this is done, no matter how much care has been taken, the segments will be found untrue and the balance out of round. The correction for this is effected by hand manipulation, and in binding the segments a great deal of care and experience is required. And as these remarks apply particularly to such jobs as occur every day in the repair shop, I shall go to some length in explanation. Suppose after cutting a balance we find the segments to spring outward; now, if we only use force enough to bend them in so that the original curve is restored we will find after a short time that the rim will have curved outward again; not as much, perhaps, as in the first instance, but still out of the true curve. To insure a permanent bend we must at first overbend the segments, that is, bend it too much, and then set it back a little. Just how much to overbend is a question only experience can decide. After the balance is cut and trued comes the actual test and trial by temperature. This preliminary trial is not made in the watch but on the poising tool. We place two screws in the holes at the ends of the balance arms and bring the balance to poise, and there subject the balance on the poising to a temperature of, say, 120° F. and note if it is still in poise; then try it in cold down to 40° F. If it stands the test we can consider it safe to go on to adjust. If it falls out of poise it is best to reject it and take another.

New Free Watch Escapement.



IT HAS repeatedly been stated in these columns, that although inventive genius has, during the past ages, devised more than one hundred watch escapements, they all, excepting two, labor under the same objection, viz.: of being too complicated for general use.

These two exceptions are the anchor and the cylinder, which have succeeded in establishing their claims to simplicity upon the severe touchstone of daily experience. The new free escapement described in the following, however, appears to possess several features not open to this charge, and the readers of THE JEWELERS' CIRCULAR may study its details, given by description and illustrations, and should they so list, reduce either their concurrence or objections to writing, and send their opinions, which will be gladly published, to this office.

In the accompanying illustrations, figs. 1, 2 and 3 show the escapement in its simplest form, while figs. 4, 5 and 6 are modifications.

Fig. 1.

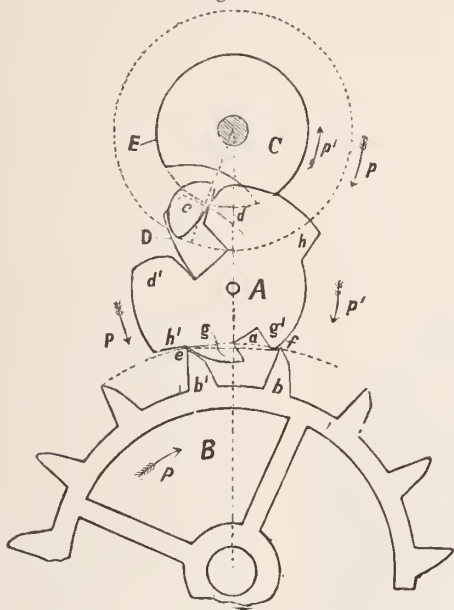

As will be seen in figs. 1 to 3, the three escapement parts *A*, *B* and *C*, have one common straight line of centers; *C* designates the motion regulator, the balance in general; it has been omitted in the cuts, and only the parts *c* and *E*, connected therewith, are shown, as they stand in closer relation with the escapement; *B* is the scapewheel, while *A* represents another new part of escapement, the impulsator, establishing the connection between the scapewheel and balance;

Fig. 2.

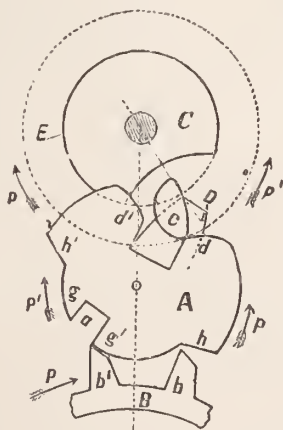

this impulsator is the characteristic part of this escapement, and makes it different from other free escapements.

Let us call the impulsator *A*, which unites both anchor and forks within itself, detent cylinder, on account of simplicity, although it does not consist of a hollow cylinder, but of a flat steel plate of

cylindrical form, which, like the pallet of the anchor escapement, sits upon an arbor with pivots.

The detent cylinder *A* is furnished around its circumference with a tooth space *a* and teeth *d* and *d'*, and enters so far into the scapewheel *B*, that the common chord *e*, *f*, is approachingly equal to the tooth division. The impulse pin *c* of the balance is arranged in such a manner that in the position of repose of the latter, fig. 3, the

Fig. 3.

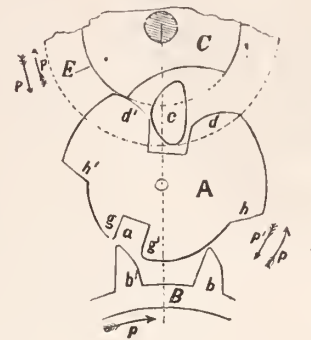

detent cylinder stands in such a way that a tooth *b* of the scapewheel can drop into the space *a*. The effect of this is that as soon as the scapewheel is impelled by the train, an impulse takes place at once in the direction *pp*, and that so far until the following tooth *b'* of the scapewheel has arrived upon a reposing plane *g* of the detent cylinder *A*, fig. 1. Both scapewheel and detent cylinder then remain stationary, while the balance continues its excursions free in the direction *p'*, the impulse pin *c* strikes against the tooth *d*, after which, by reason of the moving mass of the balance, the transposition from the position shown in fig. 1 into that of fig. 2 takes place, that is the space *a* of the detent cylinder is in such a manner carried away by the tooth *b'*, that the latter comes to lie upon the second reposing plane, *g'*.

Both scapewheel and detent cylinder again remain stationary, while the balance now continues its vibration free in the direction *p'* (fig. 2). Upon its return in the direction *p*, the impulse pin *c* strikes against the tooth *d'*, and places the space *a* again in such a

Fig. 4.

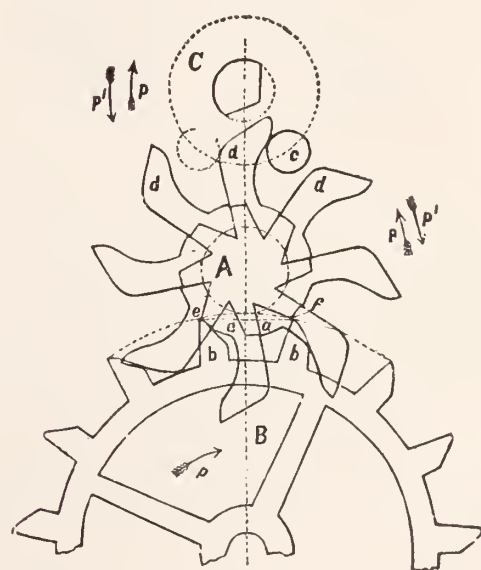

manner before the scapewheel tooth *b'*, that this, like *b* in fig. 3, enters into depth and exerts a fresh impulse in the direction *pp*. Then succeeds again the play shown in fig. 1, and the entire described procedure is repeated, which always occurs anew so long as the scapewheel is impelled by the force of the impulsion of the watch. The safety roller *E* and the tooth *D* serve for preventing the untimely unlocking and discharge the same functions as the corresponding parts in the anchor escapement. On the other hand, the shoulders *h* and *h'* of the detent cylinder alternately prevent its dis-

placement for the duration of the required repose in the positions figs. 1 and 2.

Only in the position shown in fig. 3 of the escapement parts the balance receives an impulse, therefore, at each double vibration only one, as in the chronometer escapement. The impulse is produced by the entrance of the tooth into the space *a*, while in the so-called dead beat, that is, in the transposition from the position fig. 1 into that of fig. 2, the tooth slides over the space *a*, in order to only impart the new impulse by the return of the balance in the position fig. 3. By this sliding away of the tooth over the space *a* takes place, as is easily visible, there is first a trifling advance and then a return of the escape wheel. But since a recoil might be more or less hurtful in the various uses of the escapement, it is completely prevented by a construction of the escapement shown in figs. 5 and 6.

In this disposition the radii *R* and *R'* of the repose planes *g* and *g'* are different, and the difference of the two radii is made in such a manner that the drop of the tooth from one edge of the space *a* to the other corresponds at least to the possible advance of the scapewheel teeth *b* in the transposition from position fig. 1 (now fig. 5) into that of fig. 2 (now fig. 6). By this disposition is entirely prevented, that the scapewheel in that transposition experiences a recoil. In order now to also equalize the friction of the scapewheel teeth on the repose plane of the entrance plane *g*, the arc of this plane is

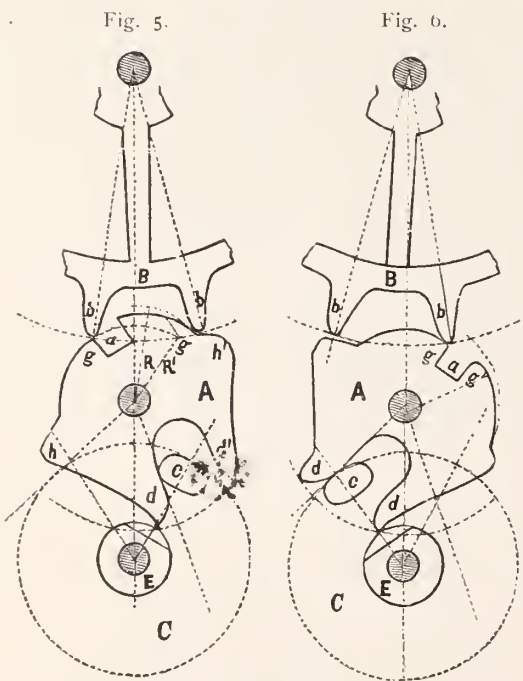

eccentric to the center of the detent cylinder *A*, and that in such a manner that the corner of the lip at the notch *a* lies closer to the center than that part of the arc lying remote from the notch *a*. In the transposition from the position fig. 5 into that of fig. 6, this arrangement effects that the escape wheel tooth *b* upon the entrance lip, so to say, passes through an inclined plane, whereby the friction is considerably diminished. The teeth *d* and *d'* are prolonged in this construction, in order to serve together with the roller *E* direct as safety tumbler, and to dispense with a different safety piece. The shape of both the safety roller and impulse pin are altered correspondingly.

This escapement is capable of quite a number of modifications, which we pass by, however, except one. The modification represented in fig. 4 appears at first glance to deviate very essentially from the original form shown in figs. 1 to 3, nevertheless, it is only another disposition of it. While the detent cylinder in the above arrangements has a to-and-fro angle motion, similar to the pallets of the anchor escapement, it moves in the modification shown in fig. 4, by pushing around its axis. This is effected by the following arrangement: The long teeth *d d'*, which in their totality form

a wheel, which moves underneath the scapewheel *G*, are unlocked by the, in this instance, circular impulse pin *C*. The teeth of the escape wheel operate upon the spaces *a a* of the upper part of the detent cylinder *A*, which also forms a wheel here, one with blunt teeth. The spaces *a a* correspond to the notch, equally so designated, of the original construction, and the blunt teeth form the repose planes. Now, if only one space *a* were to correspond with the chord *ef* between every two teeth *b* and *b'* of the scapewheel, the detent cylinder (here the double wheel *A*) would only make a to-and-fro motion, but accomplish no revolution, because *A* would, at each double vibration of the balance, be moved only by the same quality forward and then back again. But, as is shown in fig. 4, there are *two* spaces *a a* upon the distance *ef* of escapement teeth. When now the detent cylinder *A* is placed in thus, that the impulse pin *C* in the return vibration of the balance in the direction *p'*, turns the detent cylinder *A*, therefore the teeth *d d'*, only by one-half of *ef*, while in the direction *p*, by the effect of the scapewheel *B*, unconditionally the whole distance *ef* must be accomplished, there results for each double vibration of the balance a revolution of the detent cylinder *A* by one-half *ef* in the direction *p p*. This will, therefore, assume a rotary motion, since the velocity of the motion in the direction *p* is twice as large as that in the direction *p'*.

Lathes and Lathe Work.

BY THE MODEL WATCHMAKER.



THE NEW SPINDLE or arbor for holding wheels about to be described and illustrated, will hold any stem wind wheel, and present either the edge or flat side to the cutter mounted on the lathe spindle. The reader is referred back to February CIRCULAR to aid him in keeping up a clear connection of ideas. In fig. 6 in that issue is shown the device complete for cutting ratchet teeth. In our improved cutting machine we must extend the length of the bed piece *N L*, or let the piece *N* pass back farther between the joint screws, one of which is shown to the left of the crank *R*. In fig. 1 of the present issue is reproduced very nearly the cut of fig. 6 in February number with the exception that it shows the parts described in

this issue as being essential for cutting wheels whose teeth are cut more or less in the direction of the axis on which they revolve. Suppose it is required to cut a wheel, the section of which on a line with its axis is shaped as shown in fig. 2. We get a piece of steel of the proper size and form and place it on such a sub-chuck as is shown in diagram *A****, this issue. The wheel to be cut and chuck are placed in the device shown in fig. 1. It is to be understood that all the parts shown in this figure are reproduced, and also combined with the appliances described and illustrated in February. Let the reader accept the improved arbor and slide placed at *V* as a combination of all the parts formerly described and now ready for use. We will, however, add to the slide *N* a stop screw *a* and cock *b* to chuck the forward movement of the arbor *G* and slide at *F*. The cock *b* is firmly attached to the bed plate *N*, and the screw *a* stops the slide *F* on which the arbor *G* is mounted. The slide *F* referred to here corresponds to the one shown at *F* in December number. The action of the several parts will be readily understood on inspection of the cuts, but to aid we will continue the consideration of the

wheel we started to cut. We place the wheel *d* so it stands as shown in fig. 1, manipulating the screw *B* so the wheel *d* (to be cut) is presented to the center *s* as shown in fig. 2; that is, so the cutter commences to cut at right angles to the face of the bevel edge turned for the face of the teeth, as shown at the dotted line *i*. The screw *R* is now turned to advance the wheel *d* until the tooth is deep enough, when the stop screw *a* is set to stop the advance of the wheel *d* when a tooth is cut of the proper depth. The screw *R* next retracts the slide, and the division wheel *H* is set for another tooth and the process repeated. A cutter (*s*) for flat bevel wheels of American watches should be about one inch in diameter, as then the curvature of the cutter is of small importance. For cutting wheels such as are shown

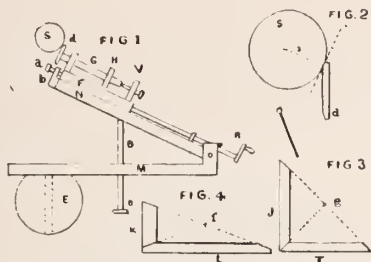

at fig. 3 (July) a smaller cutter, one about half or five-eighths of an inch in diameter, should be used. For cleansing and finishing the teeth of such wheels a fine wire scratchbrush, with tallow and flour of emery, is employed. The description of this wheel-cutting device has occupied several months, but when the entire description and cuts are taken together the reader will see the whole arrangement is extremely simple and easy of construction; and, in addition, if he will take the trouble to make one, he will have a tool capable of performing as good work as any produced. An additional advantage is that he can make his own cutter at a trifling cost, and these cutters, superior in many respects to any in the market. I will now commence the description of a more complete cutting engine, attached like the one described to an American lathe. This engine will cut any wheel used in watch work or ordinary clocks, from the smallest to a wheel four inches in diameter. It will also produce its own cutters of either epicycloidal or involute form; and its rapidity of execution can be judged from one in the possession of the writer, which will cut a tooth in a clock wheel $\frac{1}{8}$ inch thick and four inches in diameter of 32 diametrical pitch in less than three seconds. The phrase 32 diametrical pitch means that for every inch in pitch diameter there are 32 teeth in the circumference of the wheel; consequently in a wheel four inches in pitch diameter there will be 128 teeth. Such a wheel in this engine would be cut in about six or seven minutes. The parts are simple and easily made and contain many novel and desirable features. Among these is its power to produce the cutters used on the ordinary rounding up tool. The engine is also a complete rounding up tool in itself, with the advantage, as stated above, of making its own "frases" or cutters. The slides to the several parts are short and easily fitted in any ordinary workshop. And in addition to a full and complete description and working drawings of the several parts, the writer will give concise and simplified instructions for drawing and forming epicycloidal teeth.

Before we take up the details of construction, the writer would beg to impress on the mind of the reader the importance of strength and firmness in such machine. One of the best features of the American lathe is its rigidity and firmness; if it were not for this characteristic it would be hopeless to attempt to run a cutter which was large enough for clock work. I would further beg a little indulgence while I digressed a little from the description of any machine and talk a little about bevel wheels, such as are used in stem winding watches.

A fact not generally known is that no bevel or mitre wheel with teeth of the correct form can be cut with a rotary cutter. A little thought will readily convince any person of this truth, as it is evident

that in a bevel or mitre wheel the teeth must converge to a cone, as is illustrated in figs. 3 and 4. In those diagrams it will be seen that if these cones were provided with teeth the teeth would taper to nothing at the centers, spaces and teeth tapering in like proportion. Hence we see that teeth on such wheels cut with a cutter which necessarily cuts a channel of the same width, must in cutting give the teeth too much taper. Not only this error exists, but the curvature of the teeth is wrong, as the same curvature must be produced from the outer to the inner point of the tooth. When I state above that our engine would cut any wheel used in watch work, I should, perhaps, have made an exception of a cylinder scape wheel, although if we would take the trouble to fit up the cutters and laps these could also be produced. The idea of the writer is to describe a cutting engine cheaply and readily made, which can be worked as an attachment to any American lathe, which will do the very best work and do it rapidly, and, in addition, have the several parts so contrived as to be readily made by any ingenious workman.

The Watch Club System.

BY TAINTOR.



ATELY THE desire to buy goods on installments has greatly increased, especially wherever weekly payments have been introduced, and dealers in all lines are constantly besieged to trust out their goods on small weekly installments. Of course, no one can afford to sell on such terms as cheaply as he could for cash, and a great many do not have the capital to do a long credit business at all. It is to do away with these objections that a great many other dealers, as well as ourselves, have gone into the watch club business. Although in principle the clubs throughout the country are conducted in a similar manner, yet in several important details our plan is somewhat novel, and we think our experience proves it excellent.

The general plan of a watch club is to secure say, fifty members, each of whom desires a fifty dollar watch, and agrees to pay one dollar each week for fifty weeks. Then by means of some form of drawing or selection, one watch a week is given out to the members until all are supplied.

Now, we have run our clubs only forty weeks, thinking that is a sufficient time to allow any customer to pay for a watch, and instead of compelling each member to take the same priced watch, we give them the privilege of joining our club for any grade of watch ranging in price from \$20 to \$200. Each one pays us a sufficient sum per week to amount to the price of the watch in forty weeks. That is to say, 50 cents a week for a \$20 watch, 75 cents for one at \$30, \$1 a week on a \$40 watch, \$2 on \$80 and so on.

The advantage of this plan we have found to be that it pleases our customers better, and, as a consequence, it is an easier matter to secure enough members to fill a club; it also takes the "edge off" competition and the cutting of prices. For if it is attempted to run a club on any special grade of watch human nature will assert itself, and all the other dealers in town will proceed to cut the price and may succeed in breaking up the club. This they cannot do when the club is run according to our plan, unless they cut on their whole stock.

Another point in which our plan differs from some others is that

we take into our clubs anybody and everybody who desires to join, and we conduct our drawings in a perfectly impartial manner. Our method of protection against loss is as follows: Before we deliver a watch to any member we compel him to sign a paper acknowledging the receipt of it, and promising to continue his weekly payments until the whole amount is paid. We also compel him to get some person, whom we know to be responsible, to sign the paper with him, agreeing "to be responsible as security for the true and faithful performance of his contract."

The results of our career in running clubs in this manner for the past two years, is that we have doubled our sale of watches and have not lost a single cent.

We have also found it desirable not to make known the names of the members of our clubs. Ladies, in particular, object to having it known how they buy a watch or what they pay for it. For this reason we assign a number to each member, and when we have a drawing we simply announce that such a number draws the watch without mentioning the name.

We have also another novel feature in the shape of a drawing

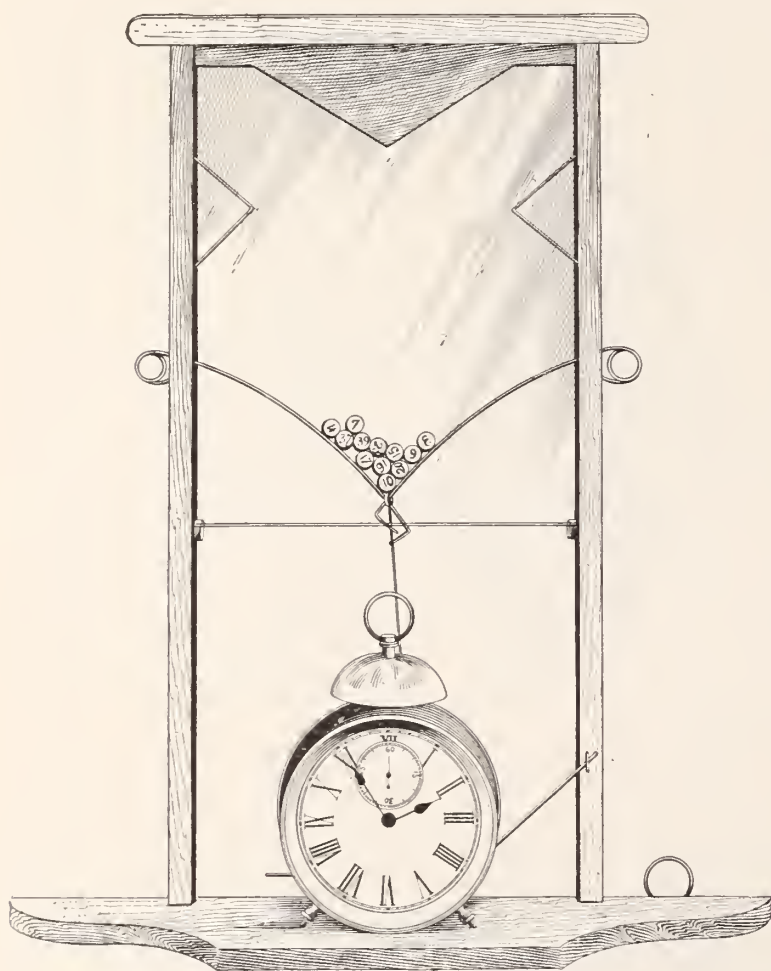

machine which is here illustrated. It consists of a small frame 17 inches high and 8 inches wide, in which are two plates of glass about $\frac{1}{8}$ inch apart. Between these we put small pieces of cork on which the numbers are printed. These corks rest on two small wire springs which extend across between the glasses. Below is an ordinary alarm clock with a cam fastened on the alarm key. A lever extends from the frame to this cam, and a fine wire connects the end of the lever with the small wire springs between the glasses. We wind up the alarm and set it to go off at the time we desire the drawing to occur. At that time the cam on the alarm key causes the lever to work rapidly up and down, and by means of the little springs between the glasses, to thoroughly shake up and mix the numbers. When the alarm is nearly run down another spring is released which pulls the two small springs down to the position shown in the illustration, and the number falling lowest in the notch draws the watch

We have found this machine of great advantage to us. As the numbers and drawings are all in sight, our customers can see that it is conducted in a perfectly fair and open manner and there is no opportunity for complaint. It has also proved to be quite an advertisement to us, as it stands on our show case, and new customers coming in are sure to ask what it is; and often by explaining the machine we are enabled to secure members for our club or cash buyers for watches. Another of its advantages is that in case we are busy waiting upon customers or are otherwise employed at the time the drawing should occur, it takes place just the same without our assistance. Of course, as much could be said in favor of any other similar machine which any jeweler might devise and construct for himself.

We have never heard but two reasons urged against the existence of watch clubs, and those are, firstly, that it is a kind of lottery, and secondly, that the dealer runs considerable risk of losing. In regard to the first, we fail to look at it in that light, inasmuch as every member is sure to get just what he pays for, and is obliged to pay for what he gets. The drawings only determine when he shall receive it. In fact, we have the written opinion of an able lawyer to the effect that in a legal sense it cannot be considered a lottery. There possibly may be more force in the other objection. But we feel confident that by a reasonable amount of shrewdness and care any dealer can conduct watch clubs with even a smaller percentage of bad debts than he can any other form of business which is not strictly a cash business, for the simple reason that in the club system he has it all his own way. First he has it in his power to refuse admittance to any person he does not desire in the club. Second, he can insist on good security before delivery or hold the watch until paid for. The members all understand the terms and cannot complain, whereas it might be quite unpleasant to ask some people, even doubtful ones, to give security under any other circumstances. The statement of the case is simply this: in ordinary selling on credit no security is given, as a rule, while in the club system it is given in every case.

So much for the objections; now for some of the points in its favor: It will undoubtedly increase largely the sale of watches, and incidentally of chains and charms. It places one's business more nearly on a cash basis, as a sufficient amount of cash to pay for it is actually received before the watch is delivered.

It enables a dealer to carry a more complete line, and so stand a better chance of selling to those who might desire to purchase for cash than he otherwise could, as his sales are assured beforehand.

It also places him in a position to take advantage of the market in buying. He can better calculate on what he is liable to sell and how much cash he will probably have on hand to pay for it.

It is a very effective weapon with which to fight off peddlers and installment agencies, as under no installment system can watches be sold with a profit at so low a price as can a regular jeweler sell them through his club. In fact, it is the only credit system in which goods can be sold as cheaply as they can for cash.

Of course, it is possible to conduct a watch club in so obnoxious and unfair a manner as to disgust all honorable dealers and prejudice people against them. This, we fear, has been done in some localities. It is a sad fact that tricksters and sharpers should be allowed to monopolize a plan which evidently can be used to so great advantage to both dealers and customers. Honorable and reliable jewelers have it in their power to conduct watch clubs in the same straightforward and respectable manner as they do any other portion of their business, and the more generally this is done, the less chance of success will there be for the unprincipled and dishonest.

IMITATION GOLD.—An alloy of imitation gold, resembling in color 12-karat gold, is made of 3 parts of platinum and 9 of copper. A good alloy for small bells, giving a nice tone, is made of 100 parts nickel, 20 parts tin, 2 parts silver and 1 part platinum.

The Oldest Known Watch in the World.

IN THE MARFELS COLLECTION.



ALTHOUGH the description of the Marfels Watch Collection was brought to a close last month, Mr. Marfels has recently been so fortunate as to procure a specimen of the very first watches made, only one of which was hitherto known to exist in the Bavarian Museum in Nuremberg. The specimen below described is doubtless still older than the latter, to judge from the work and construction.

This watch has still the round form similar to that in the Museum—a proof that the egg-shape is not the oldest form of watches; it is 6 centimeters (2.44 inches) in diameter, and 2 centimeters (0.81 inch) in height. The bronze dial has only the hour division, and is over each number furnished with a small button, which above the figure XII has a sharp point. This was for the purpose of telling the time at night. The movement is entirely of iron, and the style of execution is so nearly like locksmiths' work that no doubt can exist either to its age and maker, who was undoubtedly a locksmith. It is even



FIG. 1.

not impossible, and indeed highly probable, that we have in this specimen a sample of Henlein's watches before us.

Concerning the construction and execution of the single parts, the first thing noticeable is that this watch has no barrel. In place of this, four iron pins are in a circle fastened in the plate, between which the spring lies. Its outer end is hooked to one of the plate pillars. The spring is very crudely made, and looks more like one belonging to a door lock than a watch spring. A fusee is not yet there. For equalizing the unequal tension of the very powerful spring, which, it is evident, operates with much greater force immediately after being wound, a contrivance shown in fig. 2 is used. Upon a revolvable arbor, standing in connection with the spring wheel, is an eccentric disc, upon the circumference of which presses a roller sitting on a curved spring. When the watch is wound, the eccentric turns from left to right, until, when the watch has been

wound, the spring pressing upon the former arrives at the highest place and thereby acquires its greatest tension. In this state of tension, the roller fastened to the spring, exerts a great pressure upon the eccentric, and impedes or "paralyzes" to a certain extent the increased strength of the fully wound mainspring. In the running down of the latter, the eccentric turns from right to left so that the pressing spring is weakened to the same degree, therefore, its exertion diminishes in ratio with the decrease of the force of the mainspring. This is certainly an excellent conception, even though it be a primitive auxiliary for equalizing the unequal power of the mainspring.



FIG. 2.

Beside the plates and wheels, the pillars as well as the bridges are of iron, and show by their style of make, that the watch was made by a locksmith and, as has been shown in the recently published article, we owe the invention of watches to a locksmith.

The balance is wanting although a hole in the plate proves that there was one, but it must have been very small, and the regulation of the rate was effected by means of two hog's bristles, fastened in a slidable lever. The two arms of the balance are banked alternately against them.

The handsomely engraved bronze case and dial were formerly



FIG. 3.

smooth, as is shown by several undoubted indications; to judge from the style of work, they were engraved a number of years afterward, say about 1560.

The number of wheel teeth and pinion leaves differs entirely from the proportions used at present. The wheels and pinions are as follows: The hour wheel, 24 teeth; spring wheel, 30; center wheel, 45; its pinion, 7 leaves; third wheel, 40; its pinion, 5 leaves; crown wheel, 35, its pinion 5 leaves; vertical wheel, 15, its pinion 5 leaves. It marched about 40 hours with one winding, and the balance made 22,680 vibrations per hour.

There are various reasons leading to the belief that this watch is

perhaps the oldest specimen known, and we do not hesitate to pronounce it even older than that made about the year 1510 by Hans Gruber and kept in the Bavarian Museum.

Although, as shown in the preceding number of THE JEWELERS' CIRCULAR, the Marfels collection contains many very rare and artistic watches, yet there is perhaps not one that can compare in true interest to the watchmaker with the one above described. All the indications (which to the eyes of experts are as plain as print) point out that the beholder views one of the very earliest specimens of the chronometer of the present day; it is complete in all its details, and the successive generations of horologists have been able to correct, modify and alter only the emanation of the study and skilful hands of a simple locksmith nearly 400 years ago.

The man of thought may readily imagine how much study it cost the originator to evolve that old watch! Only think of the above mentioned eccentric disc for equalizing the tension of the spring or the introduction of the hog's bristles, in place of the balance spring; the buttons for ascertaining the time at night; the making of wheels, pinions, etc., by unaided hand and with the simplest tools imaginable. All honor to the old masters!

Quarter-Striking Work.



TWO German inventors have obtained an Imperial German patent for a striking mechanism, by which the same striking-work strikes the quarter as well as the full hours; the same hammer strikes them in different tones.

This striking mechanism is constructed in the following manner: The limb a^1 of the piece a , fig. 1, is by the four pins y on the snail x lifted every quarter of an hour, whereby the limb a^2 of the piece a issues from the tooth of the quarter rack b , figs. 1 and 3, and liberates it. This rack now falls with its arm b^1 upon the snail x furnished with four steps. As soon as the limb a^1 is liberated and can slide from the pins y , the striking-work is set into motion; the tumbler u ,

Fig. 1.

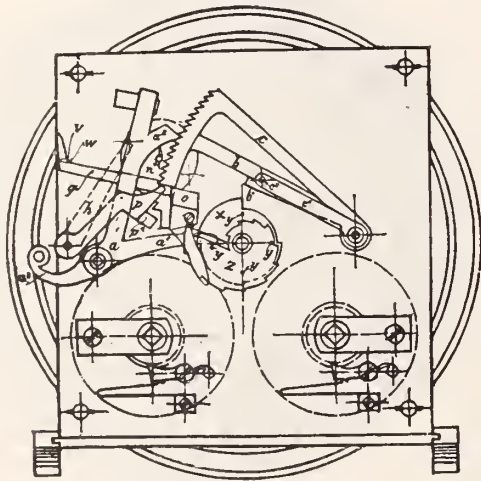

fig. 1, which sits upon the prolonged arbor of the gathering pallet wheel gears in succession into the four upper teeth of the rack b , and raises it again, whereby the shoulder p^1 of the drop arm p , fig. 1, prevents the falling back of the rack, by gearing into the four lowest teeth of the rack b . When, now, the latter is raised by from one to four teeth, accordingly as its arm b^1 had dropped upon the first, second, third, or fourth step of the snail x , then this rack is again held by a^2 , and as there are now no more teeth the rack b cannot be raised higher by the tumbler u .

But now, when the four quarters have been struck, or when the repeating arm a^3 is pulled to let the clock repeat, the hour rack c , fig. 1, comes into operation.

By drawing on the repeating arm a^3 the drop arm a , upon which

reposes the hour rack c is displaced a little by the limb a^1 , so that the rack c is liberated. The same displacement, however, also occurs automatically at the expiration of one hour, as the highest plane of the snail x twists the drop arm a a little; the rack c then falls with the pin c^2 , which is fastened in the arm c^1 , and which forms one piece with the rack c , upon the snail F , furnished with twelve steps. When now the quarters have been struck, then p^1 lies no longer upon the teeth of the rack b , but has dropped back a little, whereby p can now gear into the teeth of the rack c . This rack can now be raised tooth for tooth by the tumbler u , while the drop arm p prevents the falling back, which was not possible as long as p^1 dropped into the teeth of the quarter rack b .

When now the rack c has been raised so high that the drop-arm p can fall back by a quality greater than the depth of tooth, whereby it comes to lie upon a pin, the striking work is arrested by the lever

Fig. 2.

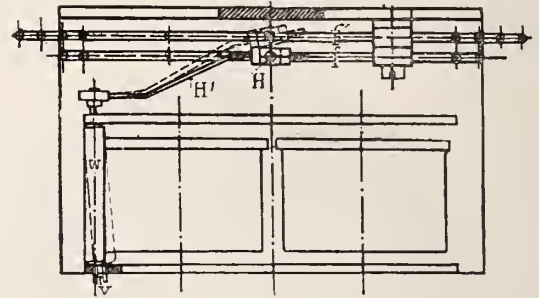
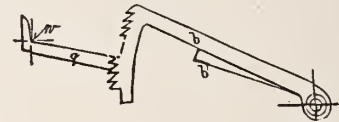

Fig. 3.



h , and stopped; but beside this, the drop arm a falls at the same time under the rack b , which prevents the hour rack from dropping back and coming into operation by the striking of the first, second and third quarter.

The hammer H , fig. 2, which strikes the quarter as well as the full hour, is by means of the hammer rod H^1 firmly connected with the arbor w . This arbor w can, in its bearings at v , be slid horizontally, and is held in position by a small spring, while the hammer strikes upon the quarter gong. But as soon as the quarters have been struck, the arbor w , is twisted horizontally by the lever g , which is firmly connected with the quarter rack b , fig. 3, whereby the hammer H slides from the quarter gong f upon the hour gong f^1 . This position is shown in dotted lines in fig. 2.

As the two gongs f and f^1 are of different sounds, the ear can easily distinguish when the quarter strokes are ended and those of the hour begin.

CLEANING SILVER.—The daily press is not distinguished for the profundity of its spasmodic dissertations on technical subjects. The following quotation, however, may be good enough for our retail jewelry store dealers to recommend to their customers what to do with their silverware: The operator requires a small sponge or a piece of flannel, a soft chamois skin, a clean, dry duster, and a silver brush. If you have no chamois, keep old, undressed kid gloves for the purpose. Rub all articles that are badly stained, such as egg spoons, etc., with salt; it will remove stains more easily than anything else. The simplest way, and one of the best, is to mix a little whitening in a saucer with water enough to make a thick paste; to this add a few drops of household ammonia. Instead of ammonia and water, you may moisten the whitening with alcohol, or with simple water; whichever way you use, the process is the same.



SALARIES AT PFORZHEIM.—The wages of workmen, according to the report issued by the Chamber of Commerce of Pforzheim, range from 15 to 25 marks per week of 60 hours for the good workmen, and from 25 to 50 marks for the excellent. An average of 18 marks may be stated to be about correct. Women earn an average of 10 marks per week, and apprentices 4 marks.

CONSUMPTION OF GOLD AT PFORZHEIM.—There were consumed in 1887, in Pforzheim, for jewelry purposes, 3,500 kilograms (1 kilogram = 2 lbs., 3¼ oz., avoirdupois) of gold, and 10,000 kilograms silver. The total value of the precious metals worked into jewelry, in 1887, was 12,000,000 marks.

HONORS.—M. Gustave Sandoz, of Paris, France, a large manufacturer of watches, etc., has been appointed an officer of the Légion d'Honneur.

A PRESENT.—The Queen of Spain has sent to the Duchess of Edinburgh, a souvenir on her recent visit to the Exposition of Barcelona. The object is a mother-of-pearl fan, ornamented with a diamond monogram and a painting executed by the Spanish painter, Melida.

A PRESENT TO COUNT BISMARCK.—King Humbert of Italy has presented to the German Secretary of the Exterior, Count Bismarck, an ornamental tankard, which is said to be a masterpiece of Italian goldsmithing. A member of the most prominent Italian masters assisted in making it. The lid is ornamented with heads of animals and leaf-work, from which rises the representation of justice, holding aloft the scales; on three sides of her are most charming figures of Truth, Strength and Fortune. The handle is formed by the figure Italia, which is said to be betwitchingly beautiful; she rests her arm upon the coat-of-arms of Savoy. A ribbon twines around the tankard, containing in enameled writing the dedication: "Umberto I Re d'Italia," and "Herbert Conte di Bismarck." The German and Italian coats-of-arms are on either side. All the details have been executed with the highest degree of perfection. The tankard was intended as a rival between German and Italian goldsmithing, and it really excels anything recently produced in Germany.

INHERITANCE.—Italian papers speak of a certain Coiraud de Lyon (apparently a Frenchman, to judge by the name), who recently died at Florence, bequeathing to the museum at Florence an exceedingly rich and artistic collection of paintings, ivories, bronzes, and antique bijouterie, valued at more than 2,000,000 fr.; to his testament he adds: "To the republican Frenchmen I leave only my hatred and contempt." A French exchange says that the good man's head must have been cracked, because, supposing even that he hated French republicans, he should not have ignored the well-known fact that there exist in France as good and fervent royalists as anywhere. Speak up, Mr. Goblet!

AN ANTIQUE MIRROR.—The French Academy of Inscriptions and Belles-Lettres has received from Dr. Carton a communication concerning a bronze mirror, which he has found in the graveyard at Bulla-Regia, while hunting for herbs. The two discs of the metal are artistically engraved. Upon one, a person is stretched at full length upon a bed, resting the upper part of the body upon one elbow; in its hand it holds a cup raised to the height of the head. Above the figure is a crescent. Upon another part of the mirror is a woman, whose lower limbs only are draped. She leans against an altar upon which stands the God of Love. She offers a laurel wreath to a person who appears to be a warrior. A soldier braces his head upon a shield. Another woman, fully draped, assists in the transaction going on. It is not known to which era dates this work of art, the execution of which is perfect.

EIFFEL TOWER.—The Eiffel Tower in Paris has been finished, and the jewelry market is glutted with its devices. Ear pendants, breastpins, hairpins, charms on watch chains, chain links—everything is Eiffel Tower.

STANDARD TIME.—"There is nothing new under the sun," is an ancient truism, yet its truth is re-affirmed every day. Electricity, it must be acknowledged, belongs to the modern epoch, but the transmittal of the hour is considered to be the very latest achievement. Nevertheless, the THE JEWELERS' CIRCULAR'S translator read in *Les Confidences*, of Robert Houdin, the inventor of the "mysterious clock," the following sentence, written thirty years ago. "I have adopted as programme: To popularize electric clocks by rendering them as simple and precise as possible. And, as art supposes always an ideal which the artist seeks to obtain, I dream already of the day when a net-work of electric wires, parted from a standard regulator, shall cover entire France and carry the correct time to the most important cities as well as to the most modest villages."

A VERY RARE COIN.—A druggist in Berlin, an ardent collector of old coins, has recently purchased a highly interesting coin, which is, perhaps, very rare at present. It is a play check—a play kreutzer of the Empress Maria Theresia, and its history is as follows: It is well-known that Maria Theresia was an extraordinarily virtuous and religious woman—yet, she had one secret passion—she loved to play at cards for high stakes with the most intimate of her court. This passion of the noble lady was a matter of great scandal to the Prince Kaunitz and the Jesuitical party, and all means, both mundane and spiritual, were employed to prevent her from playing. Finally, the private priest of the Empress was gained over to the good cause, and he succeeded in causing her to promise that in the future she would limit her bets to 1 kreutzer (= ½ cent). The Empress apparently adhered to her solemn promise, but secretly she sent for her court jeweler, and ordered of him 100 kreutzers of a peculiar construction. Each one was cut into halves, and could be unscrewed; in the interior was a small sink into which fitted a ducat (3½ grains fine gold), and these apparently innocent play checks with their precious contents were in the future used among the gambling fraternity, and only the initiated knew their value. It will be seen that although Maria Theresia was a perfect specimen of her sex, she shared in one characteristic: the possession of cunning.

THE SANCY.—Those of our readers who have at all read the accounts of the advertisements and sale of the French crown jewels, have heard of the Sancy. The following anecdote concerning this celebrated jewel we copy from *L'Intermédiaire des chercheurs*, which has exhumed it from *Le Français*—a journal no longer published. Jules Janin, the celebrated literary genius, one day visited the Louvre in company with the Princess Demidoff, who, feeling hot, removed her shawl, pinned together by a brooch in which was set the Sancy. The princess requested the author to keep safe the brooch. Naturally, Janin acceded, and slipped the jewel into his white vest pocket, and—forgot all about it. The princess did not think of her jewel on that day, but next morning she asked her husband whether Janin had returned the diamond. "No!" answered the prince. Janin is found. "Sure enough, I have the Sancy, but what have I done with it—let me think." He finally remembers, rushes to his wardrobe, and shouts to valet-de-chambre, "I left it in the white vest pocket." "In that case," this individual replies coolly, "it is at the washerwoman's." She is visited and questioned cautiously. It won't do to tempt the poor soul by telling her that the Sancy is in her possession. "Ah, yes," she answers carelessly, "a brooch—I remember; I didn't think that you wanted such an insignificant piece of glass, and I gave it to my boy to play with." Happily, the boy was still close by, and called. He did not dream, doubtless, that his plaything was worth one and one-half millions of francs. But Janin never told this story without a chill creeping over him.

WORKSHOP NOTES



BLACK FILLING FOR ENGRAVING.—Get a piece of "black ball" from a shoemaker; and on any parts desired to be filled in, rub it in hard over the engraving, then wipe it off briskly with a woolen rag. I have used the above a number of years on metal and ivory, and for the latter, it cannot be excelled.

THE DUPLEX ESCAPEMENT.—In the duplex escapement the amount of necessary drop, to insure a safe action of the parts, wastes fully one-third of the power employed; and it must be considered as an escapement that will occasion much trouble in the repairer's hands.

WHY GOLD IN JEWELRY CHANGES COLOR—It is well known that the human body contains humors and acids, similar in action to and having a like tendency toward baser metals, as nitric and sulphuric acids, have, namely, to tarnish or dissolve them, varying in quality in different persons. Thousands wear continually, without any ill effects, the cheaper class of jewelry, with brass ear-wires, while if others wore the same article for a few days they would be troubled with sore ears, or, in other words, the acids contained in the system would so act on the brass as to produce ill results. Instances have occurred in which articles of jewelry of any grade below 18 karats have been tarnished in a few days, merely from the above named cause. True, these instances are not very frequent; nevertheless, it is as well to know them. Every case is not the fault of the goods not wearing well, as it is generally called, but the result of the particular constitution of the wearer.

PROPORTION OF MAINSPRING—The following is a right proportion of the spring: Fourteen (never less than twelve) coils must lie within the spring barrel; the empty space between the spring and the core must amount to fully one-third of the barrel diameter, and the core must also measure one-third; it should be fusee-shaped, and be a complete circle with the beginning of the first inner spring coil, in order to impart as concentric a motion as possible. A protruding core hook is to be avoided, and that of the barrel must be kept as low as consistent. If all these conditions are complied with, the spring will make about six revolutions, if wound up to within one-half or three-fourths turn, and there is obtained for a going barrel making four turns, a spring power in its best attainable proportions.

OXIDIZED SILVER.—Articles of silver can be oxidized (as it is erroneously called) by introducing them into a solution of sulphur and potash (Schwefeleber, Germ.), by which the surface of the article becomes coated with a thin covering of sulphuret of silver.

THE TWO-PIN ESCAPEMENT.—The greatest accuracy is required in planting the two roller pins equidistant from the roller notch, and well out toward the roller edge, so that the space moved through on the roller edge may not be much greater than the space moved through on the circle, wherein the two pins are planted. If the two pins are much inward toward the balance staff, the roller edge will advance through a great space, while a light pallet depth is being unlocked, and in this case the roller notch will have to be very wide to keep free from the guard pin during the unlocking, and there will be a long drop across the guard pin at the impact on the pallet face, and consequently a great loss of impulse etc, and the blows on the pallet face and in the roller notch will not come so near together. If the roller notch is narrow, when the two pins are too much inward, it will be impossible to completely unlock the pallet depth by the roller pin and lever notch, for the side of the roller notch will come foul of the guard pin, and the unlocking will be partly effected by the roller pin and lever notch, and finished by the roller notch and guard pin.

TO STRAIGHTEN A PIVOT.—This may be done with an ordinary tweezers, or in the bearing of the pivot-burnishing tool, by pressing strongly upon it with a dull pivot-polishing file. Else, a small plate may be made with a number of holes of varying sizes; of this a suitable one is found for the pivot, and it is straightened in it by holding the wheel or pivot between the fingers; it may also be done with small punches with corresponding small holes; the operator must be careful, however, not to bend too much.

SILVER ASSAY BY SMELTING.—If no lead is present, mix six hundred grains of the pulverized ore with three hundred grains carbonate of soda, six hundred grains of litlarge and twelve grains charcoal in a crucible, add a slight coat of borax over all, put on the furnace, melt, take off, give a few taps to settle metal, let it cool, and remove the button.

TO ASSAY LEAD-BEARING SILVER ORE.—Should the piece of ore be an argentiferous galena or lead-bearing silver ore, mix three hundred grains of the pulverized ore with nine hundred grains carbonate of soda and thirty grains charcoal; set in a crucible on a furnace; melt, take off, give a few taps to settle the metal, let cool, and remove the button. Then re-melt the button in a porous cupel made of bone dust, which absorbs the lead, leaving the pure silver.

NEW ALLOY.—A new alloy has been discovered by Herr Reith, of Bockenheim, which is said practically to resist the attack of most acids and alkaline solutions. Its composition is as follows: Copper, 15 parts; tin, 2.34 parts; lead, 1.82 parts; antimony, 1 part. This alloy is, therefore, a bronze with the addition of lead and antimony. The inventor claims that it can be very advantageously used in the laboratory to replace vessels or fittings of ebonite, vulcanite or porcelain.

SILVERING.—A German periodical gives a method for the purpose of silvering, invented by Boettger. The articles, after being thoroughly cleaned, are suspended for about ten minutes in a bath made as follows: A fine powder of tartrate of silver is kept in suspension in distilled water, and ammonia is added until almost all the tartrate is dissolved, and the liquid shows no odor of ammonia.

SILVER SOLDER FOR GOLD PLATING.—Silver, one ounce; copper, five pennyweights; brass, five pennyweights.

TO MAKE PLASTER CASTS WATER-PROOF.—Reissig proposes for this purpose to heat the cast with baryta water, by which the calcium sulphate (of which the plaster consists) will be converted into the sulphate of barium—an absolutely insoluble substance—and caustic lime, which in the air is rapidly changed into calcium carbonate—also insoluble. The casts should be immersed in the baryta solution, which should be heated from 100° to 120°, Fahrenheit. After removing from the bath, in which they should remain several days, they are allowed to dry thoroughly, and then coated with an alcoholic solution of soap, which gives the surface a shining, lustrous appearance, and renders it impervious to moisture, so that the objects may be washed occasionally to remove any adhering dust or dirt. Plaster casts thus treated acquire a high degree of durability, and bear exposure to the weather quite well.

OILSTONES.—To keep gravers in good condition, the oilstone must always be fit for use. Constant use will soon cause the surface of an oilstone to lose its flatness, and bad hollows will soon appear upon it. When in that condition it need not be set aside for a new one. It will pay to expend a little time and some hard and uninteresting labor upon it in facing it down. This can be done by rubbing the stone upon the coarsest piece of emery cloth that can be obtained. In doing this, see that the bench, or piece of wood upon which the cloth is placed, does not round upwards, as, in that case, the surface of the stone would become concave in form—the very worst shape it possibly can have. A stone is in the best condition to sharpen gravers upon when its surface is smooth, free from hollows, and in form slightly convex. The Arkansas oilstone, only, needs a finer finish than the coarsest cloth will give.



* A Complete History of Watch and Clock Making in America.

[By CHAS. S. CROSSMAN.]

Number Thirty-Five.

Continued from page 29, June, 1889.

WATCH CASE MAKING.

GEO. COURVOISIER, L. & A. MATHEY.—THE COURVOISIER-WILCOX MFG. CO.

George Courvoisier was born in Switzerland in 1812, and served his apprenticeship there. He came to America in 1836 and established himself at 119 Fulton street, New York City, making cases for Swiss and English movements. He made a few in silver, but mostly gold 16 and 18k. He remained there until his death in 1857, when his son, Ulysses, in connection with J. L. Mathey, took the business and continued it for four years, at the end of which time L. & A. Mathey bought the business and continued it until they in turn sold it to Courvoisier, Wilcox & Company, in 1875. This firm continued it in the same location until 1878, when they removed to their present commodious factory corner of Doughty and Columbia streets, Brooklyn, N. Y. It became an incorporated company February 1, 1883, under the name of the Courvoisier-Wilcox Mfg. Company, George N. Wilcox, President; George Courvoisier, Vice-President and Treasurer, and T. K. Benton, Manager.

Mr. Courvoisier and Mr. Wilcox previous to this were both connected with the case manufacturing and watch business, importing and also jobbing American watches. When they commenced to manufacture they occupied one floor and had twenty-five employees, but increased their force previous to their removal to Brooklyn to eighty. Now they employ about two hundred and fifty hands, and are among the leading case manufacturers of the country.

FRANCIS DUBOIS & CO.

This firm started in business at No. 89 Fulton street in 1840, after having previously been connected with George Courvoisier for two or three years. The firm at first was composed of Frederick and Francis Dubois, father and son. They made English and Swiss cases. Francis Dubois withdrew from the firm later and imported watches. Frederick continued the business for some years, but afterwards he, too, went into the importing of Swiss movements. They employed a good many hands, and their reputation as gold case-makers was never excelled. They went out of the business in 1857, as times were very hard. They made the first cases for Dennison, Howard & Davis, of Boston, when they commenced to make movements in 1852.

PIGUET BROS.

Piguet Bros. commenced the watch case business in 1856. There were six brothers in the firm, viz., Adolph, Charles, Theophilus, Ely, Benjamin and Urbain, all of whom came to this country in 1849, and learned their trade after arriving here. (Their father was an engine turner). They continued together for twenty years, the whole family being engaged in case making, including two or three sisters. There are four of the brothers employed in the watch case business at the present time. They made all kinds of cases at first for

English and Swiss movements, and later for American movements. They were located at No. 4 Liberty Place, New York City.

JOSEPH FAHYS & CO.

Joseph Fahys is a native of France, but came to America in his boyhood, and in 1854 located at 71 Nassau street, where he made gold cases for English and Swiss movements. He also bought Swiss movements and cased them, and sold them as complete watches. In 1859 he began to make silver cases for American movements, being the first to make them in large quantities. About this time he moved to 16 Maiden Lane, but soon afterward he transferred the silver case business to Carlstadt, New Jersey, where it was carried on under the firm name of Foutenbach & Sons until 1878, when Mr. Fahys succeeded to the business and continued it there until 1882, when a stock company was formed and the works were removed to Sag Harbor, L. I. Here the company had erected several buildings of three stories high, covering 1,500 feet of ground, and built in the form of an H. They make about 1,200 cases a day, having added to their former product the manufacture of gold filled cases, as well as patent silver dust-proof and nickel cases. Their product of gold filled and silver cases is larger than that of any company now in the trade. They have about five hundred employees.

WARD & JENNINGS, JOHN WARD, AND ALBERT SUSSTRONG.

Ward & Jennings started in business at No. 16 Maiden Lane in 1859, the location previously occupied by Joseph Fahys, where they continued together for one year. At the end of this time Mr. Jennings retired and Mr. Ward continued the business alone until 1885. He manufactured only gold cases of a high class of workmanship, making a specialty of casing Swiss movements. On May 1 of that year he sold the business to Albert Susstrong, who had worked for him from the start. Mr. Susstrong continues the business at the same location, making the same line of cases that Mr. Ward did on a somewhat smaller scale, though keeping up the high standard of workmanship which his predecessor had set up.

LOUIS LACHET

Made cases in New York from 1860 to 1877. Then he moved to Chicago and was located at No. 70 La Salle street for four years. He then went to Kansas City, but subsequently returned to Chicago. He is now located in Louisville, Ky., and makes cases on a small scale.

JACQUES LAURENT

Commenced in New York in 1863 at 77 Nassau street. For a long time he made cases exclusively for Giles, Wales & Co. He employed a large number of hands and built up a very successful business. He probably turned out a larger number of fancy cases than any other man in the country at that time. Emil Laurent, his brother, afterwards joined him, and the firm became J. Laurent & Co. for a few years. They remained here two years and then removed to 17 John street, where they were located until 1878, when J. Laurent moved to Linden, N. J. Mr. Laurent proceeded to erect a large brick factory, with accommodations for 300 workmen, and intended to make both gold and silver cases, but the business was not successful. It was wound up shortly afterward, the tools and machinery being sold to Hagstoz & Thorpe, of Philadelphia.

JOHN GIFFIN.

John Giffin learned the trade of watch case making in 1832 with John L. Ward, 44 Fulton street, New York, when there were only three or four casemakers in the city. Mr. Ward made open face cases with gold dials up to 1840, from twelve to twenty-four cases a week being considered a fair business. In 1854 he made the first

two gold cases for the Howard & Davis American movement, which ran eight days and were very large.

D. BOURNIQUE

Started about 1865 at Middletown, Pa., and afterwards removed his business to Milford, Pa. He made silver cases, selling his entire production to Chas. Glatz, of New York, who conducted the business six months and then sold it to the Association of Silver Case Manufacturers. Mr. Bournique died in 1883.

GUSTAVUS WILLEMIN, AND WILLEMIN WATCH CASE CO.

Gustavus Willemin, founder of the Willemin Watch Case Co., learned the trade of case making with Messrs. Gigon, Pequignot & Bro., of Philadelphia. Upon the dissolution of that firm in February, 1863, he was taken into partnership with Gustavus Gigon, under the firm name of Gigon & Co. He remained with Mr. Gigon until 1867, and then went to New York, where he entered the employ of Mr. Cronin, at the corner of Broadway and Cortlandt street. After working here for eighteen months he returned to Switzerland, his native country. He remained there for two years, and, returning to Philadelphia, once more entered the employ of Mr. Gigon.

In 1875 he went as foreman with Messrs. Courvoisier & Wilcox, and remained with them until 1882, when he started in business for himself in Brooklyn, manufacturing fancy gold cases. He died in 1887, and the business has since been transferred from Brooklyn to Philadelphia, and incorporated with the filled case business of H. Muhr's Sons.

JOS. H. H. PENTON.

Mr. Penton served his apprenticeship with Messrs. Bowman & Everts, commencing with them in 1846. In 1852 he went with Francis Dubois & Co., and remained there a number of years. In 1865 the firm of Penton, Ludlam & Underhill was formed and a location chosen at 25 John st. They remained there but one year, after which Mr. Penton went out of the firm and carried on a business alone a short time in Brooklyn, at the junction of Adams and Fulton sts. Soon afterward his former partners separated and the original firm was entirely dissolved.

Mr. Penton afterwards went to Huntington, L. I., and started business as a silver case maker, but soon afterward returned to New York and began business at 65 Nassau st. Here he stayed two years, removing finally to his present location at 38 Maiden Lane, where he has been located for about twelve years as a maker of special cases.

BALL, STEFFANY & CO. AND BALL, PARKER & WATERS.

The first-named firm started a co-operative shop May 1st, 1870. The firm was composed of nine journeymen case makers, as follows: T. F. Ball, Geo. L. Waters, C. Linderman, F. Gueringue, F. Steffany and his brother L. Steffany, A. A. Jeannot and J. F. Durand. Mr. Jeannot was business manager and foreman.

They were located at 42 State st., Brooklyn, and all remained in the firm until the spring of 1875, when six out of the nine withdrew, and the remaining three, viz.: Messrs. Jeannot, Ball and Waters, associated with them William Parker, and changed the name of the firm to A. A. Jeannot & Co. They continued together until 1880, when a dissolution again occurred, Mr. Jeannot going out of the firm, and the new firm name being changed to Ball, Parker & Waters. They then removed to their present location, 21 Cliff st., New York city. This firm has always maintained a high standard of workmanship, making only the best cases, and has done quite a large and successful business.

The co-operative company employed about forty men and turned out about one hundred gold cases a week. The first year they made a few silver cases for American movements but none since then. Messrs. Ball, Parker & Waters employ at present about fifty men and make many fine cases on special orders.

CHARLES SCHWITTER.—THE FIDELITY WATCH CASE CO.

Charles Schwitter went into business in 1877, at Nos. 40 and 42 State st., Brooklyn, in a building known as the glass house, with a silent partner named Frank Steffany, under the firm name of Charles Schwitter. Mr. Steffany withdrew in about six months and died soon afterward. His interest in the business was sold to Courvoisier, Wilcox & Company, and Mr. Schwitter was connected with them as a partner for one year, after which a dissolution took place. He did not, however, have means sufficient to carry on his business alone and soon took as a partner a watchmaker named Peter Renaud, who remained in the firm about two years. Mr. Schwitter stayed in this location until 1879, when, the building being destroyed by fire, he removed to No. 380 Water st., New York city, where he carried on business until, in January, 1888, a stock company was organized under the name of the Fidelity Watch Case Co., with a capital of \$125,000. The officers of the company are Charles Schwitter, President, and A. G. Funck, Secretary and Treasurer. Their factory remains at the same location, and they employ about one hundred men in the manufacture of all grades of gold cases.

THE CHICAGO WATCH CASE COMPANY.—THE CRESCENT WATCH CASE COMPANY.

The Chicago Watch Case Company was established in Chicago in June, 1882, with a capital of \$50,000, the officers being, M. S. Smith of Detroit, Mich., president; S. H. Hale, the Chicago agent of Robbins & Appleton, vice-president; M. A. Mead, of Chicago, secretary and treasurer; W. H. Fitzgerald, also of Chicago, general superintendent.

Mr. Hale was the chief promoter of the enterprise and choosing as he did M. A. Mead, who had long held positions of trust with the American Watch Company, as business manager, and Mr. Fitzgerald as superintendent, he obtained men thoroughly competent for the extensive business which the company secured from the outset. The product of this company was confined to gold filled cases and a moderate line of gold cases, mostly 10 kt. Mr. Fitzgerald proved to be an inventive mechanic as well as an efficient superintendent, as they soon began to turn out what proved to be a popular line of goods. The business which began with about thirty hands soon employed from fifty to sixty, and turned out some four hundred cases a week. After nearly three years of successful operation, during which time Mr. Mead had concluded to engage in the jobbing business, it was decided to move the Chicago Watch Case Company's plant to Brooklyn, N. Y. The business management was then placed in new hands, but the manufacturing department continued under Mr. Fitzgerald's direction. The business was reorganized and incorporated under the laws of the state of New York, and the name changed to the Crescent Watch Case Company. Within a few months after being settled in Brooklyn the working force and production was largely increased. While not claiming to rank with the largest watch case companies of the country, as to the quantity of the goods turned out, they do claim to make watch cases second to none in shape, finish and quality. Their entire production is sold through Messrs. Robbins & Appleton, agents of the Waltham Company, at 5 Bond st. The present officers are: President and General Superintendent, Walter H. Fitzgerald; Treasurer, A. M. Crommelin; Secretary, W. E. Matthews. The facilities possessed by this young company are such that we shall not be surprised to see it steadily gaining in popularity and in patronage.

to the extent that eventually it will be found among the leading producers of watch cases.

THE BROOKLYN WATCH CASE CO.

The Brooklyn Watch Case Company was at first a private enterprise. It was started in 1865 in a small factory at No. 42 Pearl st., near Franklin Square, New York City, with about fifteen employees. They occupied this about a year, after which they removed to 42 State street, Brooklyn, and organized the present company. They remained in this location four years at the expiration of which they bought lots and built a brick building four stories in height at the corner of Fourth Avenue and Warren street, which is their present location. At this period, Mr. Darling, the superintendent, became a member of the company. When the firm first commenced they made both gold and silver cases but the manufacture of the latter was soon dropped, and an extensive line of gold and a small line of gold filled cases have since been made. They began to make the "Eagle" case in 1876, which under its trade mark of "Brooklyn Eagle" has become one of the most popular and staple cases in the market. The Brooklyn is one of the most enterprising companies in the trade. The present officers are L. A. Parsons, President, F. E. Parsons, Secretary and Treasurer. Mr. E. P. Ellsworth is now the General Manager of the New York office, which is located at No. 11 John street, in the new Corbin Building.

JULIAN FAVRE & GUINAND

were located at the corner of Ann and William streets, making cases about 1840. They had a small shop and kept three or four workmen, many branches being done outside.

THE ROY WATCH CASE COMPANY.

In January, 1885, Messrs. Aug. X. Roy, Charles Chevalier and Aimee Girard, all of whom had long held responsible positions in watch case factories, entered into a co-partnership and located in York street, Brooklyn, as manufacturers of fine gold watch cases.

It was but a few months before the young enterprise met with a disastrous fire which completely destroyed its plant—but without delay and with redoubled energy the partners re-organized as a stock company under the present name, at the corner of York and Washington streets. With increased capital and a good equipment, the product was placed on the market under the business management of Mr. Louis de Goll, formerly with the Illinois Watch Co., who became a stockholder. During the fall and winter of 1885 this company made efforts to revive the bassine shape in watch cases, and called attention to the advantages of that style for rich and varied engraving and decoration. The idea met with a favorable reception in the trade. The company found it expedient, early in 1886, to open an office at No. 1½ Maiden Lane. The company soon became widely known through its specialties, among which photo-enamelling attracted general attention. This was a process for the reproduction of photographs upon watch cases, fired upon an enamelled ground. It has recently been supplemented by their new photo-miniature reproduction, fired directly upon the gold cap of the case.

In 1887, the office of the company was removed to No. 3 Maiden Lane. At the same time Mr. Joseph Girard, well known as one of the most skillful case turners in the country, withdrew from partnership in the Willemin Watch Case Co., and entered the Roy company, as stockholder, and took charge of the turning department.

The output of the factory has steadily grown. Traveling salesmen cover the territory from Boston to Denver, and an office has been opened in San Francisco, under the charge of Mr. Fred. E. Mason, dealing directly with the jobbing trade there. The product is confined to the higher grades of gold cases, in 14 and 18 karat, engraved and ornamented, raised gold and enameled work being special features.

Kremenz & Co. vs. The S. Cottle Co.



THE SUIT of Kremenz & Co. vs. The S. Cottle Co., for alleged infringement on a patent collar button of the former, known as the "one piece," came to trial in the United States Circuit Court for the Southern District of New York during the past month, before Judge Wallace, resulting in the dismissal of the bill, the judge holding the opinion that the patent is invalid for want of novelty. The opinion is appended:

The patent in suit granted to complainant May 6, 1884, is, in the words of the claim, for "A collar or sleeve button having a hollow head and stem, the said head, stem and the base plate or back of the said button being shaped and made of a single continuous piece of sheet metal, substantially as shown and described." The specification and drawings describe and illustrate a button in the form of a stud. It is made of a single piece of metal without soldering or joints. By means of any suitable dies a metal plate is pressed into the form of a cap with a flange or rim at the bottom, and then the sides of the cap are pressed together about the middle in any suitable manner to form the head and stem.

The prior state of the art may be sufficiently understood by referring to only two of the several earlier patents in the record. The patent to Stokes, No. 171,882, granted January 4, 1876, describes a stud composed of one piece of sheet metal in which the head and stem are made by striking them up or raising them out of the metal base plate by means of a punch and die. The stud is of substantially the same form as the stud of the complainant's patent, except that the head is flat instead of round; the stem is hollow and the head is solid. The patent to Keats, No. 177,353, granted May 9, 1876, describes a button or stud made of a single piece of sheet metal having a hollow head and hollow stem, and is of the same form as the stud of the complainant's patent. It has an extra shank or base plate. In making it the sheet metal blank is formed in two sections having the desired configuration, one of which is doubled over upon the other, and the edges are brought together by lateral pressure.

It thus appears by the two prior patents referred to that the complainant was not the first to make a hollow stud, or a hollow stud from a single piece of metal, or a stud from a single continuous piece of metal, or a partly hollow stud from a single continuous piece of metal. So far as appears he was the first to make a stud from a single continuous piece of metal in which the head was hollow and round in shape. The stud of the Stokes patent would be his if the head were not flat and preferably solid, instead of being round and hollow. The stud of the Keats patent would be his if it were not folded over and joined by lateral pressure at the sides so as not to be made of a continuous piece of metal. For the particular use for which the Stokes stud was designed a flat and solid head was preferable; and for the particular use for which the Keats stud was designed a joint or seam at the sides was not objectionable. For the use for which the complainant's stud was designed a round head was preferable and a seam at the sides was objectionable. He desired to improve upon his predecessors by making a stud without a seam, and thus obviate the necessity of soldering, and which should be hollow throughout and thereby save material, and he desired to make a stud differing somewhat in details of the configuration of the parts from that of Stokes or Keats. The idea and the method of making a seamless stud out of a single continuous piece of metal was suggested and fully shown by the patent of Stokes; and the idea and method of saving material by having the entire stud hollow was suggested and fully shown by the patent to Keats. It is not open to reasonable doubt that any competent mechanic, versed in the manufacture of hollow sheet metal articles, having before him the patents of Stokes and Keats, could have made these improvements and modifications without exercising invention and by applying the ordinary skill of the calling. Indeed, the stud of the Stokes patent alone is a substantial anticipation of the complainant's patent. The different manipulation of the blank necessary to introduce the desired modifications of form, and the hollow head which distinguish the studs was within the obvious knowledge of the skilled mechanic.

It must be held that the patent is invalid for want of novelty. The bill is dismissed with costs.

Kremenz & Co. at once filed an appeal to the Supreme Court of the United States.

EFFECT OF BAD DEPTHING.—Many repairers are puzzled by the fact that many watches that come into their hands for the purpose of cleaning only, with a good character for past performance, will not go at all when cleaned and mounted again. This arises from the depths having been set by forcing the cocks in the required direction with the pliers the last thing, and when unscrewed, these resume their original position.



[FROM OUR SPECIAL CORRESPONDENT.]

MINNEAPOLIS, Minn., June 17, 1889.

THE MINNESOTA RETAIL JEWELERS' ASSOCIATION PERFECTED—ITS
PLAN AND MEMBERSHIP.

Mention was made in this correspondence last month of the movement which had been set on foot among the jewelers in St. Paul and Minneapolis to establish an association for their protection. The meeting was held on the evening of the 20th of May at the West Hotel in this city, at which the organization of the association was completed by the election of the following officers: President, T. B. Myers, St. Paul; Vice-President, J. B. Hudson, Minneapolis; Secretary, A. C. Clausen, Minneapolis; Treasurer, P. F. Egan, St. Paul. Executive Committee—T. B. Myers, St. Paul; A. C. Clausen, Minneapolis; C. Marshall, Minneapolis; J. E. Ingham, St. Paul; F. Williams, Stillwater; C. J. Odell, Windom; J. H. Isham, Duluth.

There were a large number of the men in the trade in the twin cities present, besides representatives from a number of the towns throughout the State. The temporary Secretary also had with him, and presented to the meeting, a large number of letters from dealers scattered throughout Minnesota, which were all of one tenor. A very decided sentiment was expressed that some organization must be perfected to protect the legitimate retail dealers against the damaging competition from jobbers' catalogues, watch clubs and general dealers. Nearly a hundred letters of this character were received, the most pointed of which were read at the meeting. Acting upon the very evident desire for an organization, the gentlemen present adopted the following Constitution. By-Laws were also adopted.

CONSTITUTION.

ARTICLE 1.—NAME.

This Association shall be known as the Minnesota Retail Jewelers' Protective Association.

ARTICLE 2.—MEMBERSHIP.

The members of this Association shall be retailers in watches, jewelry and kindred goods, and who make the selling of such goods their principal business.

ARTICLE 3.—OFFICERS.

SEC. 1. The officers of this Association shall consist of a President, Vice-President, Secretary and Treasurer, who shall be elected at the annual meeting by ballot to serve for one year or until their successors are elected. A majority of all the votes cast by members present or represented by proxy (which must be in writing) shall elect.

SEC. 2. The officers and Executive Committee shall be elected at the annual meeting, and the newly elected officers and Executive Committee shall be installed at that meeting to serve for one year.

SEC. 3. The Executive Committee shall consist of the President, Secretary and five members, who shall be elected by ballot and hold office in accordance with Sections 1 and 3, Article 3, of this Constitution.

ARTICLE 4.—MEETINGS.

SEC. 1. The annual meeting shall take place on the second Tuesday of May, at such place as may be designated by the Executive Committee. Ten days' notice of the annual meeting shall be given.

SEC. 2. Special meetings shall be called by the President on the written request of three members of the Executive Committee.

SEC. 3. Notice of such meeting shall be mailed to each member five days previous to each meeting.

SEC. 4. Should any vacancy occur in the board of officers it shall be filled by the Executive Committee.

ARTICLE 5.—AMENDMENTS.

Notice of alterations or amendments to this Constitution must be proposed in

writing at any meeting, and shall be acted upon at the next meeting. Five days' notice, in writing, of such proposed change shall be mailed to each member by the Secretary.

Since the meeting the membership has been augmented by the following retailers in St. Paul and Minneapolis, who constitute the greater majority of all the retail dealers in these two cities:

Myers & Co., P. F. Egan, J. E. Ingham, Bookstruth & Lee, M. Albrecht, J. D. Bodford, Thomas Gaskell, A. H. Simon, F. M. Finch, Bullard Bros., Emil Geist, C. C. Bergh, G. L. Rohardt, F. A. Defield, W. H. Breen, Chas. Beard, Stahl & Martin, Geo. R. Holmes, John Pheister, Wm. Anderson, H. Von Unroe, O. H. Arosin, A. L. Haman & Co., Geo. E. Reed, St. Paul; J. B. Hudson, A. C. Clausen, B. B. Marshall & Son, E. W. Storer, W. C. Leber, S. Legale, Tindolph & Co., Wm. Bard & Co., Eustis Bros., H. F. Legg, Weld & Son, Winter & Lueck, J. R. Elliot, J. N. Weinstein, S. Jacobs, A. Sanborn, J. M. Donaldson, L. Metzger, Joseph Ridgeway, L. F. Barker, W. B. Woolsey, A. Mauseta, J. A. Vlasak, A. Peterson, O. T. Thompson, C. A. Olson, C. Weding, F. W. Hanson, S. Dobrin, Minneapolis.

The Executive Committee have also sent out to the retail dealers and watchmakers throughout the State the following letter, accompanied by the pledge which follows:

To the Retail Jewelers and Watchmakers of the State of Minnesota:

At a meeting of representative retail jewelers and watchmakers, held at the West Hotel, Minneapolis, May 20, 1889, a Constitution and By-Laws was unanimously adopted and a permanent organization formed. The purposes of this Association are the protection of the retail jeweler from the inroads made upon his business by the promiscuous distribution of jobbers' catalogues and price lists, the selling of our goods by the dry goods, auction, general stores, watch club and installment houses. The extent of this outside business is apparent when it is estimated that not more than one-half of the watches at present sold to consumers throughout the United States are sold by the legitimate retail jeweler; and in other lines pertaining to our business the trade has largely passed into the same channels. By your co-operation and a harmonious effort of our members we expect to remedy these evils and largely abolish the cause of our many grievances. We attach a list of members, comprising nearly the entire trade of St. Paul and Minneapolis, as an evidence of our initial success, and enclose a copy of the Constitution and By-Laws with a membership application.

A tidal wave is sweeping over the entire country such as has never been known before in the history of the jewelry business. We hope ere long to be organized into one grand national body for the correction of manifest abuses affecting the interests of the entire trade. Please sign the application, enclose \$5 with business card, and address it within ten days to the Secretary, A. C. Clausen, 244 Nicollet avenue, Minneapolis, Minn.

If the sentiments expressed in the letters were any indication, the organization will be a very complete one before many weeks. All this has been given somewhat in detail, because the Secretary of the association has already received numerous inquiries from different cities throughout the United States, asking for some indication of the plan and manner of the organization.

The recently organized Minnesota Watch Company, mention of the near incorporation of which was made in my last letter to THE JEWELERS' CIRCULAR, is engaged in conducting a watch club, and advertising their enterprise largely in the daily newspapers. The company have established an office at the corner of 4th and Robert streets, St. Paul, which is under the management of J. D. Caldwell, and are selling watches to members of the clubs for \$40 each, payable in \$1 assessments, after a method already familiar to the trade. The company is said to be already doing a large business on the plan which they have adopted.

TRANSPARENT CEMENT.—According to a French journal, a good transparent cement may be made from the following recipe: Mix in a well-stoppered bottle ten drachms of chloroform with twelve and a half drachms of non-vulcanized india rubber in small pieces. The solution is easily effected; when finished, add two and a half drachms of mastic, and let the whole macerate from eight to ten days, but without heat. The cement produced is perfectly white and very adhesive.



TRADE GOSSIP.

The following out of town dealers visited New York during the past month :

J. Kahn Chicago, Ill.; A. J. Phillips, Albany, N. Y.; H. Davis, Pittsburgh, Pa.; J. M. Smith, Detroit, Mich.; J. Wright, Toronto, Can.; Mr. Hewitt, (Lancashire Watch Co.) England; J. F. Beyerle, Reading, Pa.; Edward Koehn (Patek, Philippe & Co.) Geneva, Switzerland; I. Schloss, Detroit, Mich.; J. K. Welden, Binghamton, N. Y.; E. Harris, Washington, D. C.; F. Sherman, Albany, N. Y.; W. Wilcox, Utica, N. Y.; M. Schwob, Montreal, Can.; R. Winzenried, Cleveland, Ohio; A. Staib, Baltimore, Md.; C. Hadenfeldt, San Francisco, Cal.; J. Christiansen, Chicago, Ill.; J. M. Duff, Lexington, Ky.; E. Hill, Cleveland, Ohio; C. A. Hoffmann, Minneapolis, Minn.; M. Sternberg, Savannah, Ga.; H. D. Woodruff, Albany, N. Y.; C. Roth, Denver, Col.; C. C. Terry, Hudson, N. Y.; S. D. Mills, Kansas City, Mo.; L. Lake, Baltimore, Md.; E. Rowe, New Haven, Conn.; J. McKee, Pittsburgh, Pa.; G. Blum, Philadelphia, Pa.; B. Strauss, Buffalo, N. Y.; J. F. Rand, Portland, Me.; H. Kohn, Hartford, Conn.; J. Zineman, Philadelphia, Pa.; J. Gibson, Kansas City, Mo.; F. Dutton, Boston, Mass.; D. Oppenheimer, Baltimore, Md.; E. A. Giles (Giles, Brother & Co.) Chicago, Ill.; F. W. McAllister, Baltimore, Md.; C. Weaver (Bailey, Banks & Biddle,) Philadelphia, Pa.; A. Paul, Boston, Mass.; N. G. Wood, Boston, Mass.; R. Friendly, San Francisco, Cal.; E. Burr, Philadelphia, Pa.

—August Loch, has moved from 149 to 145 Federal st., Allegheny, Pa., and has, perhaps, the largest and finest store in the city.

—Harry B. Thornbury, buyer for C. G. Alford & Co., 200 Broadway, New York, left the City June 7, for a sojourn in the Adirondacks.

—A. G. Funck, the genial secretary of the Fidelity Watch Case Co., 192 Broadway, left on the 15th inst. for a brief sojourn in Europe.

—Reed & Barton, Taunton, Mass., designed and executed the prize cups, raced for at Lake Quinsigamond, Worcester, Mass. June 17.

—E. A. Haldimann has moved his business from 24 John st., New York, to 3 Maiden Lane. He will hereafter confine himself almost exclusively to jobbing American watches. His card appears elsewhere in this issue.

—Wm. C. Greene & Co. have moved their New York office from 17 Maiden lane to 192 Broadway, Corbin Building, room 37, where the trade are requested to call and examine their new line, which is more complete than ever before.

—The Wiesbauer Mfg. Co., of Buffalo, N. Y., are at present making an unusually fine line of paper boxes. Their latest conceit is a Turkey red telescope ring box, the printing being in gold, and the lining of dead white colored plush.

—The Rogers & Hamilton Company, Waterbury, Conn., have commenced a suit for damages for alleged libel against W. H. Watrous, president of the Wm. Rogers Company of Hartford, Conn. It is charged that Mr. Watrous has written letters libelling the Cimeter Rogers brand of goods, manufactured by the plaintiffs.

—Henry Froelich & Co. have established themselves as wholesale dealers in plated jewelry at No. 40 Maiden lane, New York. In plated novelties, Mr. Froelich knows exactly the needs of the trade, and can present to the retailer the right kind of selling goods. The firm intends to keep on hand only well selected and new goods.

—Waterman & Lehmann, manufacturers of rich diamond jewelry, 37 Maiden lane, have prepared an elegant line of diamond mountings for the fall trade. In addition to manufacturing this staple line they give their personal and immediate attention to orders for single work, also deal largely in loose diamonds at very close prices.

—Leopold L. Adler, of L. Adler & Co., importers of precious stones and manufacturers of diamond mountings, 44½ Maiden Lane, New York, left for Europe, June 22, by the *Enns*. Although Adler & Co. have a resident buyer in Paris, and receive invoices of goods—diamonds, rubies, sapphires and other precious stones—by almost every steamer, customers will no doubt find in their fall lines, some parcels of goods, above the average importations in excellence. As Mr. Adler is thoroughly versed in his line of business, his experience extending over a period of 30 years, (favorably known to the trade from his long connection with L. Strasburger & Co.) his visit abroad will produce good results to the firm.

—S. F. Myers & Co., 48 and 50 Maiden Lane, New York, are offering in their "New York Jeweler" for June, special reductions in discontinued goods, particularly in Elgin and Cheshire movements, and in various makes of cases. They are also closing out preparatory to assuming the sole agency of a new clock company, an entire line of staple clocks.

—The Derby Silver Co., Birmingham, Conn., have been so successful with a number of their patented designs in manicure sets, toilet brushes and mirrors, that imitators have been infringing on them. They notify the trade in this issue that suits have been commenced against the infringing parties, and caution all dealers about handling the spurious goods.

—The season of commencements, competitions and tournaments having set in, dealers should bear in mind that E. R. Stockwell, 19 John street, is headquarters for such things. He is prepared to furnish designs for anything that may be wanted in this line, including school medals, shooting, canoeing and rowing prizes, bicycle, lawn tennis, baseball and military trophies, etc.

—L. F. Cornwell, Salida, Col., who was robbed in May of goods valued at fully \$2,000 by his watchmaker, Henry T. Strauss, as reported in the June CIRCULAR, has issued a notice giving full descriptions of the refugee and of the goods stolen, and offering \$200 reward for the former's arrest and recovery of 30 per cent. of the goods; or \$100 for the arrest with any portion of the stolen property.

—The Ott & Brewer Co. of Trenton, N. J., have issued together with a neat folder giving a descriptive history of their Belleek China, a beautiful circular formally announcing the opening of their show room at 177 Broadway, New York, fully described in the June CIRCULAR. A cordial invitation is extended to the trade to visit and see this handsome little apartment.

—W. C. Edge & Sons, following the example of others have removed their office from 15 John street, New York, to their factory 46 Green street, Newark. They have a fine line of new charms for queens and centers for vest chains. The new necklets and bracelets illustrated on another page, are well liked by the trade and are an important addition to this popular class of jewelry. These goods are made in both Roman and polished.

—After an existence of eighteen years, the firm of Burdick & Otero, Pueblo, Col., was dissolved last month, Charles Otero purchasing his partner's interest, and continuing the business under his own name. It is Mr. Otero's intention to increase his stock and add several other lines, giving him perhaps as complete jewelry establishment as there is in Colorado. Mr. Burdick with his family will shortly leave Pueblo for Washington Ter.

—Cross & Beguelin, 23 Maiden Lane, New York, recently received large imports of horse timers in nickel cases, and split second timers in nickel cases. These goods are offered at extremely low prices, and are very accurate, the former being in use by many horsemen. The firm has also a large assortment of split seconds timing watches, in gold and silver cases. As they have no travelling salesmen, we would advise the trade to send for the firm's price list.

—Wade, Davis & Co.'s line of samples this season, is undoubtedly the most extensive and beautiful that the firm has ever put upon the market, and the manner in which orders are being placed, fully attests the appreciation of the trade. Their line of bracelets of which they make a specialty, is unusually large, and excellent in styles and quality, and Mr. Whiting, the firm's genial representative is on his mettle, accommodating his customers in the best possible manner, as he is ever anxious to do.

—New and attractive designs are constantly being added to the stock of L. A. Cuppia, who, in his new and commodious quarters at 42 East 14th st., New York, is provided with the most improved machinery and appliances for the manufacture of sterling silver goods. Mr. Cuppia's stock is both extended and varied and includes specialties not to be found elsewhere. Special attention is called to a full line of bracelets and bangles; also to artistic cane heads and umbrella handles of silver with exposed ivory and pearl.

—The Alvin Manufacturing Co., 24 Boudinot street, Newark, N. J., illustrate in this issue of THE CIRCULAR a specimen of the rare and beautiful work for which their name is becoming famous in the trade. It is called Alvin ornamentation and consists in the application upon crystal glass of a delicate tracery of silver work in flower and leaf designs. The effect is exceedingly rich, pleasing the most refined and artistic taste. In addition to this specialty the Alvin Co. have a very complete line of novelties in silver, including cane heads, toilet articles, etc. Their work in the electro-deposit process is worthy of special praise.

—Frederick Dreher, who formerly was in the jewelry business at 1,668 Second avenue, has taken a shop at 16 Maiden lane, and will do business as repairer for the trade. Mr. Dreher is an experienced and earnest young man, and deserves the patronage of the trade.

—The firm of Arnstein Bros & Co., of 37 Maiden lane, have loomed up into prominence within the last few years as one of the leading jobbing firms in American movements. The Messrs. Arnstein are also importers of diamonds, which are placed before the trade at very close rates. We are very glad to be able to record the success of this enterprising circle of brothers.

—The Middletown Plate Company of Middletown, Conn., are actively preparing an exceedingly large and handsome line of new goods for the coming Fall trade. The line covers staple table ware in every variety, brushes, combs, mirrors, candelabra, cigar boxes, bonbons, toilet sets, manicure sets, in fact a full assortment in every class of staple and fancy goods. After July 1 samples of every line can be seen at the company's New York office, 22 John street.

—As the racing and athletic season generally now at its height brings with it a heavy demand for timing watches dealers throughout the country will be recipients for some months hence of inquiries for such articles. This being the case, they would do well to bear in mind that J. Eugene Robert & Co., 30 Maiden lane, New York, have a most complete stock of these articles on hand; a special feature of which is that they combine medium cost with accuracy and reliability.

—The Pairpoint Mfg. Co.'s factory at New Bedford, Mass., is running full time, producing an extended variety of new goods, including many novelties, for the Fall trade. On another page of this issue may be seen representations of two of three beautiful patterns in flat ware, the "Myrtle," the "Ivy," and the "Hawthorn," which the company have just brought out, and which, being put up in plush-lined boxes, like the company's other fancy pieces of flat ware, including pie and cake knives, etc., are already in lively demand.

—C. G. Braxmar, 36 Cortlandt street, New York, has issued free to the trade an illustrated catalogue and price list of badges, medals and charms of his own manufacture. The catalogue contains nearly one thousand designs. The illustrations of the goods are very finely executed and the price list attached makes it altogether one of the most complete books of its kind ever issued to the trade. Mr. Braxmar is no new comer in his business, for he has been established in this city for more than ten years, and has acquired a reputation for producing fine goods as well as for business probity.

—Day & Clark, goldsmiths, 10 Maiden Lane, New York, have now ready for the Fall trade many new and elegant designs in rich gold jewelry, of which we need specify but their new curb and link bracelets, graduated link bracelets, and single stand extension bracelets, mounted either with diamonds or with pearls and turquoises. Lace pins have long been a favorite manufacture of this firm, as well as earring covers, those in vermicelli finish at present being in much favor. Their stock of bead necks in single, three and five strands, Roman or polished, is full and handsome. A few designs are represented in another portion of this issue.

—A watchcase which has just been placed upon the market, and which promises to command a goodly sale, is known as the "Owl," and is the latest production of Pinnell, May & Co., 52 Lawrence st., Newark, N. J. It is an 8 karat case, and the trade mark, an owl stamped in the back, with the initials, P. M. & Co., in the cap, guarantees it to be as represented—that it is 8 karat in quality and that it will stand a pure nitric acid test without discoloring, and every other test that a case of its guaranteed quality can be put to. In appearance the "Owl" equals a 14 karat case. These qualities aside from the beauty of design and excellence of execution of the cases should pique the curiosity of jobbers.

—As may be expected at this season of the year, Rogers & Bro., 16 Cortlandt street, New York, are making a specialty of silver plated prize cups and premiums for yachting, sailing, rowing, shooting, bicycling, lawn tennis, baseball and other contests, and shows and fairs, and are finding an active demand for them. Loving cups, some with three handles, others with two, are also being made a specialty at present. The firm is negotiating to supply a prominent New York hotel with one hundred three branched candelabra, to be placed upon the hotel's tables. It is proposed to connect them with some electrical source by a most simple contrivance, which if successful, as we have no doubt it will be, will, we predict, bring about a revolution in hotel illumination.

—Charles E. Medbury, representative of Fred. I. Marcy & Co., Providence, R. I., is visiting the western trade with the most complete line of Acme lever buttons he has ever shown.

—J. B. Bowden & Co. are now thoroughly comfortable in their new handsome offices in the Corbin Building, where with their increased facilities they are able to discharge all demands made upon their handsome line of gold rings.

—Following the terrible episode of the Conemaugh Valley, came the news of the destruction by fire of the business portion of the flourishing town of Seattle, Wash. Ter. The exact particulars of losses and insurances are not yet obtainable, but it is estimated that among the unfortunate jewelers H. C. McLaughlin & Co. lost between \$10,000 and \$12,000, with no insurance. Giering & O'Donnell's establishment was completely blotted out. Other jewelry stores that were burned to a greater or less degree, were those of Frisch Bros., L. Greenberg, Albert Hausen, W. H. Finck, G. G. White & Co., G. E. W. Bowers, and Gerhard Benninghauser. Next to Giering & O'Donnell and H. C. McLaughlin & Co., the greatest loser is Albert Hausen, whose stock was damaged to the amount of \$10,000.

—The Riley-Osborn Manufacturing Co., of Newark, N. J., have removed their New York office to the Prescott House building, 529 and 531 Broadway, N. Y., where they have secured elegant parlors on the second floor. Their catalogue of Silver and brass goods is one of the most complete we have ever seen in this line. We take this occasion to remark that there are many articles of solid silver manufacture which are quite beyond the reach of a very large class of good customers, but which the retail dealer can secure, as this firm reproduces many of the most useful of these manufactures in brass and silver, which are equal in design, finish and durability, to the solid silver sets, at a mere fraction of the expense; and in addition the firm guarantees that these goods will not tarnish. This remark is especially applicable to toilet sets, mirrors, etc., etc. In brass goods the catalogue contains many designs of furniture, art goods, lamps, clocks, match holders and many other "boudoir" articles. Dealers visiting the city cannot spend an hour more profitably than in examining the stock of this firm at the above location. See their advertisement on page 2.

—On June 1 the Board of Assessors of Pittsburgh, Pa., published their returns of the business tax assessments of the first eight wards of the city down to the amount of \$25,000. The total assessment shows a decided increase over that of last year, demonstrating that business in that city is in a notably prosperous condition. It is reasonable to presume that the jewelers are sharing in this prosperity. The following are the assessments as far as they refer to jewelers: Heeren Bros. & Co., wholesale, \$325,500; Goddard, Hill & Co., wholesale, \$250,000; I. Ollendorf, wholesale, \$200,000; Heckel, Bieler & Co., \$200,000; Barrett, G. B. & Co., wholesale, \$198,500; Roberts, E. P. & Sons, retail, \$168,300; Bonn, M. & Co., wholesale, \$162,600; Grogan, J. C., retail, \$150,000; Slemmons, J. O., wholesale, \$125,000; Kingsbacher Bros., wholesale, \$120,000; Wattles, W. W., retail, \$100,000; Biggs, G. W. & Co., retail, \$100,000; Wattles & Sheaffer, retail, \$92,800; Reed, J. R. & Co., retail, \$700,00; Hardy & Hayes, retail, 57,400; Seidle, R. & Co., retail, 51,000; Grafner Bros., wholesale, \$50,000; Hauser, C. S., retail, \$50,000; McKee, James, retail, \$50,000; Terheyden, Henry, retail, \$40,000; Will, C. C. & Co., retail, \$25,000; Durbin, H. H. & Co., retail, \$25,000.

—W. H. Butler, 79 Duane st., New York, agent for the Diebold Safe and Lock Company, of Canton, O., announces that his company have effected several improvements in their steel lined fireproof safes, which are designed especially for use by jewelers. These safes are guaranteed by the manufacturers to represent the best qualities as to fire and burglar resistance. The special production of this company for jewelers' use is their Independent burglar proof safe, which has all the latest improvements in a modern bank safe. It consists really of two safes, the burglar proof portion being secured within a fire-proof safe, each having separate doors and fastening mechanisms, and each adding to the protective qualities of the other. These safes contain many original and exclusive features that essentially show the highest work, such as our solid welded angle frame, patent round cornered door and hard drying fire-proof filler, chrome steel plates and screws, straight carrying hinges, interlocking air-tight tenons and grooves, patent cut-off spindles, pressure bar and anti-dynamite attachments, silver bronze finish, nickel plated trimmings, etc. The company's object is to produce a perfect construction, combining good fire and burglar proof security with a minimum of cost, and they have no doubt fulfilled it.

—Charles Van de Sande, has severed his connection with Henry Carter, 198 Broadway, New York, and will shortly start in business on his own account.

—J. W. Richardson & Co., 196 Broadway, New York, are contemplating issuing a supplement to their catalogue that will contain a large number of new patterns in masonic emblems, charms and pins.

—D. R. Corbin, of 10 Cortlandt street, New York, illustrates a bracelet in this issue and notifies the trade that certain parties have been infringing on the patent which he holds. He has commenced suit against the infringers and will hold responsible all who handle these pirated goods in future.

—George T. Bynner, a gentleman widely known in the trade, has accepted the position of traveling salesman for the Alvin Manufacturing Company of Newark, N. J., and is now showing their fine line of sterling silver novelties to the trade. A full line of samples can always be seen at the New York office of the company, No. 10 East 14th street.

—Henri P. Hoffer, for three years past head of the watch repairing department of J. Eugene Robert & Co., 30 Maiden Lane, New York, has left that firm and has associated himself with Jens F. Pedersen, 1½ Maiden Lane, as watchmaker and salesman. Mr. Hoffer is a graduate of the Horological School of Geneva, Switzerland, which fact, together with his long experience, will guarantee him a goodly amount of patronage.

—The improvements effected in the office of Howard & Son, 176 Broadway, New York, make it one of the cosiest and handsomest in the trade. A little apartment has been partitioned off to offer better facilities for showing goods, though we suppose Howard & Son's line would command almost as many sales were they displayed under circumstances even worse than the old ones. S. C. Howard returned last month from his California trip and reported good business.

—The firm of Henry E. Oppenheimer & Co., 47 Maiden Lane, New York, has been dissolved by mutual consent, Norbert and David Gunzburger retiring, and Henry E. and Milton E. Oppenheimer continuing the business under the old style, and assuming all liabilities. The Messrs. Gunzburger have for the present made their headquarters with Henry Dreyfus & Co, 25 Maiden Lane, where they continue as importers of diamonds and manufacturers of diamond mountings. They have adopted the style of Gunzburger Bros.

—The prevailing style of goods made by Simpson, Hall, Miller & Co., and known throughout the trade as the *repoussé*, is at present claiming the capacity of their factory. Large lines of these goods will be shown for the fall trade. The beauty of the *repoussé* goods has always been admitted, the only objection ever existing being their rather high price; but now, by the process of hand work introduced by Simpson, Hall, Miller & Co., these staple goods can be furnished at a price that brings them within the reach of every dealer.

—The Crescent Watch Case Co. have just issued the second edition of their handsome linen mounted panel, the first edition having been issued a year ago. This panel contains representations of fifty new designs of engraving on crescent cases, printed in black upon white paper mounted on linen. The beauty of the press work, together with beauty of the designs and ensemble, should make dealers eager to possess one, as an advertisement as well as an ornament to their stores. They will be sent to dealers only upon application accompanied by business card.

—On the 6th of June, Judge Wallace in the United States Court in New York, heard the subsidiary motions in the actions of the Dueber Watch Case Manufacturing Co., against Allen C. Dalzell and the Fahys Watch Case Co. The latter company have appealed against Judge Wallace's recent decision. The plaintiffs motioned to have the appeal bond fixed at \$50,000. This was refused, the sum of \$1,000 being ordered. Counsel for plaintiff moved an injunction to restrain the defendants from using the patents during the motion for a new trial but the motion was refused.

—Persons of inventive genius and enterprise are invited to exercise those qualities and be liberally rewarded, as may be seen by reading the advertisement of Henry E. Oppenheimer & Co. in another portion of this issue. This firm offers \$50 for a design of a single stone ring mounting, to combine beauty, originality and practicability. The competition is extended not only to the retail dealers, but also to their employees behind the counters, who are apt to be good judges of the demands of the market. The prize will be awarded on September 15, so we would advise prospective competitors to commence at once agitating the gray matter of their brains.

—The office of Wm. C. Edge & Sons having been removed to Newark, the portion of the office at No. 15 John street, formerly occupied by them will be rented, furnished or unfurnished, very low to a desirable tenant. Parties desiring information should call on Wm. H. Ball & Co., 15 John street.

—R. Blackinton & Co., of North Attleboro, are showing through their representative J. R. Morss, the finest line they have ever produced in gold, rolled plate and sterling silver. The line embraces bright cut bangles, flexible ball bracelets, buckles in large variety, hairpins, in silver and rolled plate, side combs, and a number of new patterns in their staples, brooches, lacepins, etc. They also manufacture the well known Krementz bracelet in rokt., rolled plate and sterling silver oxidized.

—The offices of Ostby & Barton and the Plainville Stock Co. have been handsomely improved. The two offices have been partitioned off, the show tables and fittings have been repainted, a new carpet has been laid, in fact, everything has been altered and bettered, and a cosy and pretty office is the result. C. W. Seymour, the Plainville Co.'s good-humored representative, assured THE CIRCULAR'S young man that trade was already far ahead of the same time last year, and submitted to his criticism his lines of goods for this season, which, if perhaps not larger than those of previous years, contain more new and handsome designs, though the Plainville Co.'s lines have always been admitted to be among the handsomest in the trade. New designs in brooches and lace pins in unpolished and Roman gold combined, others in plain Roman, a pretty new line of knife-edge bar pins having in the center a pentangular design with a small white stone set in each end, a fine line of black diamond horseshoe brooches, a neat line of drops with turquoise and garnet ornamentations, and drops and scarf pins with the pentangular design are among the company's novelties for this season.

—A little circular that is being issued by the Spencer Optical Mfg. Co., and which every progressive dealer should be desirous of reading, speaks fully of the company's aluminum spectacles and eye-glasses, which are, month after month, creating for themselves a greater and greater demand. To enumerate the intrinsic merits of aluminum would be perhaps superfluous, as they are widely known. It is commonly admitted by scientists to be the lightest metal existing; it is known not to tarnish or to be affected in any way by atmospheric action, in appearance to resemble the finest burnished steel, to be pre-eminently durable, having the ductile strength of steel and to have the flexibility of gold. Spectacles or eye-glasses made of this metal does away with that dragging feeling so often produced by their constant use. The spectacles are made with the regular single bow, and with very light flexible riding-bows, also riding-bows with spiral adjustment at the lower end of the bow which adjusts itself to the varying distances between the *temples* and the *ears*; this spiral is protected by a tube, which does not disfigure the spectacle or make it appear cumbersome, but equalizes the pressure back of the ears and prevents the ridging of the nose common to the old style.

—For several days, pedestrians on Maiden Lane were attracted to the windows of Aikin Lambert & Co., at No. 23 and the Spencer Optical Co., at No. 15 in which were displayed some pathetic tokens of the recent disaster at Johnstown, Pa. In the former window were several miscellaneous pieces of jewelry, a few watches, and about a dozen pen holders, battered, covered with mud and ruined. They were the property of J. A. Larkin & Co., and represented about all that had been found of their original stock valued at about \$4,000. They had been unearthed fully a square away from the store. In the Spencer Co.'s window was displayed the remains of one of their cases of trial lenses. The case was battered and the top knocked off, but not a lens was lost from its celluloid frame, as would have been the case had the frame been of steel or other metal. Mr. Larkin tells of his miraculous escape from death upon the roof of a floating frame house, where he remained for over twenty-four hours. Aikin, Lambert & Co., have made good the portion of Larkin & Co.'s stock destroyed composed of their goods, and have forwarded to the stricken firm, a safe and various articles, to help to recommence business. Among other customers of Aikin, Lambert & Co., who were affected by the flood, were T. W. Kerlin, who with his family and business was completely lost, and J. W. Stevenson, who had the good fortune to be saved with his family, though he lost all his personal property. Every jeweler of the city suffered to some extent. S. F. Blough and wife and property lost; Louis Luchhardt, Sr., and daughter-in-law dead, and property destroyed to extent of \$50,000; W. A. Kraft lost his whole family as well as his small stock; Mrs. Susan M. Young lost \$1,200, her husband and son were killed, and John H. Sedelmeyer lost all his small business, and his family were killed.

—J. B. Laurencot, importer of optical goods, arrived home from his European trip on the 25th ult. Opticians should examine the new importations that he has sent over. Mr. Laurencot holds out an invitation to jewelers visiting the Paris Exhibition to make use of his Paris house under "Hotel Terminus," where they can have their correspondence sent, and where orders, etc., will receive prompt attention.

—One would think that the opportunity for the execution of a numerous variety of designs in thimbles would be little, but if he were to look over the stock of thimbles manufactured by Ketcham & McDougall, he would be quickly undeceived. This firm has, no doubt, the largest as well as the most handsome line to be seen in the trade. They have lately placed several new designs upon the market. A line with checkered bands, made in 10-k and 14-k., is very handsome and is commanding a goodly sale, as does also a line with chased oval bands in 10-k. and 14-k., with either ornamented or plain edges. A couple of lines that are in especially good demand are the firm's oxidized silver thimbles, with rose or lily-of-the-valley decorations, occasionally gem ornamented with pearl or diamond, and their embrociderly thimbles of bright cut silver or gold, the whole outer surface being in floral designs chased. The firm's standard No. 105 is being made with faceted edges and fine cord rim; the No. 103 and No. 101 have been also improved. Samples will be cheerfully sent to dealers desiring them.

—The jewelers responded liberally to the call for aid for the Johnstown sufferers, as may be seen by the appended lists. These of course do not include the numerous sums subscribed by the employees of firms collectively:

From the New York Jewelers' Board of Trade:

Oppenheimer Bros & Veith . . . \$100.00	Crouch & Fitzgerald..... 25.00
Simpson, Hall, Miller & Co.... 50.00	Sinnock & Sherrill..... 25.00
Sussfeld, Lorsch & Co..... 50.00	Adolphe Schwob..... 25.00
H. W. Wheeler & Co..... 50.00	Stern & Stern..... 25.00
Downing, Keller & Co..... 25.00	E. Ira Richards & Co..... 25.00
E. Karlsen..... 25.00	Wiggers & Froelick..... 20.00
Wm. Smith & Co..... 25.00	Engelfried, Braum & Wiedman.. 15.00
S. F. Myers & Co..... 25.00	Levy, Dreyfus & Co..... 15.00
A. Lorsch & Co..... 25.00	A. Pinover & Co..... 10.00
Enos Richardson & Co..... 25.00	A. S. Gardner & Co..... 10.00
L. & M. Kahn & Co..... 25.00	C. S. Smith..... 10.00
Lissauer & Sondheim..... 25.00	Hodenpyl & Sons..... 10.00
Max Freund & Co..... 25.00	A. Goldsmith & Co..... 10.00
Chas F. Wood..... 25.00	L. Sauter & Co..... 10.00
Falkenau, Oppenheimer & Co., 25.00	Geo. W. Pratt & Co..... 10.00
Stern Bros & Co..... 25.00	Guinberg & Glauber..... 10.00
Louis Herzog & Co..... 25.00	J. B. Laurencot..... 10.00
Hahn & Co..... 25.00	Chas. Jandorf..... 10.00
Marx & Weis..... 25.00	Odenheimer & Zimmern..... 10.00
Julien Gallet & Co..... 25.00	Sol. Lindenborn..... 10.00
Henry Dreyfus & Co..... 25.00	Paul Jeanne..... 10.00
Goodman Bros..... 25.00	H. Z. & H. Oppenheimer..... 10.00
Helter & Bardel..... 25.00	Henry May..... 10.00
G. & S. Owen & Co..... 25.00	Leon P. Jeanne..... 10.00
M. Fox & Co..... 25.00	Cash..... 10.00
Dennison Mfg. Co..... 25.00	J. H. Johnston & Co..... 10.00
Keller & Untermeyer..... 25.00	Arnstein Bros. & Co..... 10.00
D. L. Van Moppes..... 25.00	L. Weil & Co..... 5.00
Pforzheimer, Keller & Co..... 25.00	Henrich & Graves..... 5.00
L. Tannenbaum & Co..... 25.00	C. Knapp..... 5.00
S. Eichberg..... 25.00	Henry Zimmern & Co..... 5.00
Geo. W. Schiebler..... 25.00	H. C. Haskell..... 5.00
Heilbronn & Blank..... 25.00	Jacot & Son..... 5.00
J. W. Johnson..... 25.00	L. Adler & Co..... 5.00
Joseph Fahys & Co..... 25.00	J. W. Block & Co..... 5.00
F. Bing & Co..... 25.00	R. A. Breidenbach..... 5.00
M. D. Rothschild..... 25.00	Chas. A. Gallagher..... 5.00
Bruhl Bros & Co..... 25.00	W. I. Rosenfeld..... 3.00
Blancard & Co..... 25.00	Cash..... 3.00
L. S. Friedberger & Co..... 25.00	J. F. Angell..... 3.00
I. Goldsmith & Co..... 25.00	Leon Hirsch..... 2.00
Ladd Watch Case Co..... 25.00	Novelty Mfg Co..... 2.00
F. Kroeber Clock Co..... 25.00	I. L. Russell..... 2.00
Waterbury Watch Co..... 25.00	Hattie J. Bunzel..... 2.00

From the New York Jewelers' Association:

Randel, Baremore & Billings... \$100.00	J. Eugene Robert & Co..... 25.00
Carter, Sloan & Co..... 50.00	Eisemann Bros..... 25.00
Wm. S. Hedges & Co..... 50.00	C. G. Alford & Co..... 25.00
Krementz & Co..... 50.00	Smith & Knapp..... 25.00
Dominick & Haff..... 50.00	Thomas G. Brown & Son..... 25.00
Rogers & Bro..... 50.00	N. H. White..... 25.00
Shafer & Douglas..... 50.00	H. C. Hardy & Co..... 25.00
Alfred H. Smith & Co..... 50.00	Spencer Optical Mfg. Co..... 25.00
Peterson & Royce..... 50.00	Aikin, Lambert & Co..... 25.00
S. Cottle Co..... 50.00	J. H. Johnston..... 10.00
Taylor & Bro..... 25.00	Cash..... 10.00
Jaques & Marcus..... 25.00	Hebbard Bros..... 5.00
Fowler Bros..... 25.00	

—The latest price-list of the Mosely lathe and attachments, issued last month by Mosely & Co., Elgin, Ill., contains many changes to suit the times and the watchmakers.

—Charles Glatz is now comfortably located in his new offices in the Corbin Building, room 37, where he will continue to carry on an extensive assortment of watch cases and movements.

—Mathey Bros, Mathez & Co., 16 Maiden lane, New York, are fully prepared for the peculiar demand of the season with a large line of fine timing watches. The department of demagnetizing watches is kept very busy; their process of demagnetizing, which is kept secret, is perhaps, the most effective in use.

—A very pretty advertising conceit, consisting of a cardboard fan, on one side of which is a representation of a young female face with a pair of opera glasses to her eyes, the lenses being made of blue isinglass, is being issued by R. & L. Friedlander, 65 Nassau street, New York. Dealers desiring some of these fans should apply at once.

—James Peacock, who recently succeeded Mr. Dayton as New York representative of Fred. I. Marcy & Co., of Providence, has taken a new office in the Dennison Building, one floor above the old one, where he is now ready for the campaign with an unusually fine line of Acme buttons. Mr. Peacock was formerly with the defunct firm of F. G. Whitney & Co.

—Koch & Dreyfus are now fully settled in their new quarters at 22 John street, which are among the best equipped in the jewelry district. The store at New Orleans has been entirely closed out, and Mr. Koch, Sr., is now en route for Europe. The firm report a considerable increase in their business over last year. Mr. Hirsch has just returned from Europe with large purchases of diamonds.

—The furore excited by the placing on the market of the puzzle ring by Henry C. Haskell, some time since, has not yet subsided by any means. The volume of sales of this article has been veritably marvelous. Mr. Haskell is issuing an attractive little puzzle ring circular that dealers would find advantageous to their interests to place in their show windows. Mr. Haskell's new office in the Corbin Building is now in perfect working order, and with his increased facilities he finds it a pleasure to submit to his visitors' criticism a handsomely odd line of twist rope, knot and snake rings, gem-ornamented with pearls or garnets in silver, so oxidized as to give the appearance of antiquity, a pretty line of silver bracelets, silver-topped hairpins, and a multiplicity of other lines.

—Group 3, class 26, at the Paris Exposition is the display of H. H. Heinrich, the well-known watch and chronometer maker of 14 John street, New York, and consists of three chronometers, each containing a distinct invention of the makers. In the first is a simplified application of weight for compensation in ordinary temperature from 40 to 95 degrees Fahrenheit; in the second an auxiliary balance for compensation in extremes of temperature, self-adjusting compensation, and in the third a new system for regulating the isochronism, and for regulation in positions. The *Jewelers' Weekly* of June 6 contained a portrait together with a sketch of Mr. Heinrich's life, which was so well written that the subject of the sketch has had a number of reprints made and is distributing them among his numerous friends.

—On Friday afternoon, June 21, J. E. Spencer, of the Spencer Optical Mfg. Co.; W. R. Alling of Alling & Co., and J. B. Bowden of J. B. Bowden & Co., composing a committee appointed by the directors of the New York Jewelers' Association, to meet such committee as the New York Jewelers' Board of Trade should appoint to confer on the advisability of amalgamating the two organizations, met the latter committee, composed of F. H. Richardson, of Enos Richardson & Co.; David Keller, of Pforzheimer, Keller & Co., and S. F. Myers, of S. F. Myers & Co., at the Board of Trade's rooms in the Knapp Building. After several hours conference, during which much headway was made, the meeting adjourned till 3 o'clock Tuesday, June 25. No apparent obstacles stand in the way of consolidation, which if consummated, as it undoubtedly will be, will make the New York Jewelers' Board of Trade the strongest jewelers' association in the country. At the meeting of June 25, nothing was settled; but there is a general sentiment prevailing, among the members of both organizations, that the union must take place. No sufficient reason can be assigned for the contemporaneous existence of two such organizations. Their objects being practically similar, the existence of both must necessarily weaken each other, for strength is divided where it should be combined. The consolidation will always retain the name "New York Jeweler's Board of Trade," though it was at first proposed to substitute the word "United" for "New York

—On the 17th ult., several prominent jobbers, at the solicitation of G. Blum, of J. A. Schwarz & Co., Philadelphia, assembled at the Metropolitan Hotel, New York for the purpose of expressing their views and adopting some plan whereby to alleviate the many grave abuses to which they are subjected at the hands of several manufacturers. The jobbers assert that these manufacturers make it a practice to sell their goods to retailers and dry goods dealers at the same prices as they sell to them, thereby competing with their own customers. That the idea of preventing such practices was approved may be gathered from the fact that within one hour a temporary organization was effected, and the name, "The Wholesale Jewelers' Protective Association of America," decided upon. Circulars advising the jobbing trade of the object of the association, and asking for co-operation will be issued. Mr. Blum said that he expects within a month to have organized the jobbers of Philadelphia, Chicago, St. Louis, Pittsburgh and Cincinnati, as they are only awaiting the action of the New York houses. The meeting was adjourned till 3 P. M. June 21, to meet at the Board of Trade rooms. At this meeting a Committee of Plan and Scope was appointed, and met at the Metropolitan Hotel, June 25th. They made very satisfactory progress in formulating their plan and constructing their constitution and by-laws. They reported that they had already received written applications from some sixty out-of-town jobbers, and also from a large number of firms in New York who had not attended the previous meeting. The communications heartily endorsed the feeling in the trade, that a decided and a firm step must be taken to remedy many of the existing abuses. The organization will be secret in its character, and will have representatives from all the principal cities. They will invite the manufacturers to express the position that they propose to assume in the future, recognizing the right of every business man to trade as may be to his best interests; though holding at the same time that it is against their interest to handle or purchase the lines of such manufacturers who cater direct to the retail dry goods trade without discriminating in prices, in the belief that such goods found in the large dry goods bazaars, and sold at a margin proportionate with that yielded by dry goods has worked and is working the greatest injury to the retail jewelers throughout the country.

THE WATCH AND CLOCK COMPANIES.

—The tempering and annealing room of the Elgin factory is to be rebuilt and generally bettered.

—The Waltham factory will be closed for vacation, Friday evening, July 12th, and will re-open Thursday, Aug. 1.

—Machinery is now being placed in the works of the Otay Watch Company, which was completed about a fortnight since.

—The Manhattan Watch Co. have already received many orders for their new filled case watch that they introduced a month or so ago.

—The present capacity of the Elgin company's factory is approximately 1700 watches per day. It is said that the number is to be increased.

—George E. Knight, secretary of the Rockford Watch Company, married last month Miss Maud Price, daughter of President Price of the company.

—The employees in the establishment of the Manhattan Watch Co. contributed \$35 to the fund for the amelioration of the condition of the Johnstown survivors.

—At the Sydney (New South Wales), Exhibition, just closed, the Seth Thomas Clock Co., was awarded a gold medal. The Ansonia Clock Company received a third prize.

—The Keystone Watch Club Co., of Philadelphia, at the end of May declared a quarterly dividend of 2½ per cent. and placed \$5,104 to the account of their net earnings.

—The American Waltham Watch Company have issued their new line of 14 size hunting movements in 18 k., 14 k., 10 k. gold, silver and crescent filled cases. These movements have been placed upon the market to parallel the pendant set 14 size open face, issued some months since.

—Wm. F. Gardner, who has supervision of the exhibit at the Paris exposition, illustrating the United States government time service, under the date of May 21, reports to Mr. Thomas that the Seth Thomas Clocks shipped to Paris for that purpose, had all arrived in good condition.

—The formal articles of incorporation of the new factory at Otay, Cal., have been filed with the secretary of state at Sacramento. Directors R. D. Perry, H. P. Woodward, J. W. Guion, M. D. Hamilton, E. H. Miller, P. H. Wheeler, S. B. Hamer and D. R. Moore. The capital stock is \$175,000.

—The Waterbury Clock Co., 10 Courtlandt st., New York, are preparing a new catalogue, that will be ready for distribution by August 1. It will contain representations of numerous new things.

—The Rockford Watch Company are still increasing their factory's capacity, and it is expected that by August 1 the daily output will be 250. It is at present about 200, which scarcely supplies the demand. The "New Model" placed upon the market last January has passed through the crucial test of a first season and has become a success.

—The new watches of the Trenton Watch Co. are on the market and jobbers are placing large orders for them, which fact would indicate that the new "Trenton" is a success. The company's endeavors to make a serviceable and reliable timekeeper and sell it at a price within the reach of the masses are fully exemplified in this new watch which should be seen to be fully appreciated.

—The first distribution of the "New Nickel" Cheshire will be made August 1. The improvements in this watch consist of a second-hand, back ratchet and hinged bezel with imitation gold joints. The price is but slightly more than that of ordinary Cheshire. That the "New Nickel" will prove a success is already evidenced by the numerous orders, aggregating several thousand watches, that are waiting at this writing to be filled.

—The Terry Clock Co. is no longer in existence. The company was recently dissolved, Messrs. Russell & Jones retiring, and a new company, to be known as the Globe Clock Co. was organized, of which S. F. Myers & Co. are among the heaviest stockholders. The new company, whose works are at Bristol, Conn., will manufacture an extensive variety of nickel and walnut flamed clocks, and S. F. Myers & Co. will retain the agency, as with the dissolved Terry Clock Co.

—The Keystone Standard Watch Co., Lancaster, Pa., have lately made some changes which will greatly improve its product and exert a very favorable influence upon its future career. On May 1, A. Bitner was superseded as general manager by H. J. Cain, formerly superintendent of the Hampden Watch Co. Already the good effects of the change are apparent. Several new improvements have been added to the company's list, which will be ready for the Fall trade.

—The Columbus Watch Company, have now ready for delivery their first new open face pendant set movements, to make room for the manufacture of which several grades of their open face lever sets were discontinued. These latter discontinued grades are now being sold at quite a reduction; which many dealers are taking advantage of. The company are considering the matter of the removal of their works from one end of the city to another, where considerable more room will be obtainable, to accommodate increasing business.

—The annual meeting of the stockholders of the United States Watch Company of Waltham, was held on Saturday afternoon, June 8. The following officers were elected: President, Thomas B. Eaton of Taunton; Treasurer, Emil C. Hammer, of Boston; Clerk, James E. Cox, of Waltham; Directors, Emil C. Hammer, Thomas B. Eaton, T. F. Hammer, Granville Nutting and A. E. Hammer. The company have been widely extending their operations of late. They will shortly have their new 6 size movement ready for delivery. It is said to be one of the finest ladies' watches made in America.

—By August 1, the Illinois Watch Company will have ready for delivery their new 14 size open face pendant set. By the same date, it is expected that the works will be running with their regular force of workmen, on full time. The laying off of some of the hands as previously reported, is but temporary, and is mainly caused by the lack of hands in the finishing department. At one time several thousand watches were awaiting finishing, owing to this lack of sufficient facilities, and to prevent increase and to balance the several departments, numerous names had to be temporarily stricken from the lists.

—In the early part of the month the foundation stone of the first English watch factory which adopts the American principle was laid, by Lady Margaret Cecil. Gracefully referring to Lord Derby's enforced absence from Prescott, she accepted from the Chairman of the Lancashire watch company a silver trowel and ivory mallet, proceeded with the ceremony, and in a clear and audible voice assured the 2,000 people assembled that "the stone was well and duly laid." Miss Emily Faithfull, who was called on to move the vote of thanks, expressed her interest in the new departure as offering a wide field for the employment of women, and as the step most likely to save a British industry fast being ruined by the importation of foreign watches.

—During the second week of June, the Seth Thomas Clock Co. contracted for a large tower clock for the Union Depot, in Ogden City, Utah, and for a large striking clock for the State Capitol at Harrisburgh, Pa. The company are experiencing a good demand, considering the season of the year, for their small nickel clock, the "Pony," which they expect to sell in large quantities for the fall trade. The large quarter-striking clock for the court-house of St. Paul, Minn., and the clock for the *Chronicle* building in San Francisco, Cal., were shipped during the latter part of last month. The latter was fully described in a recent number of THE CIRCULAR. It has four 16 ft. dials the centers being $11\frac{1}{2}$ feet.

—Patek, Philippe & Co., of Geneva, Switzerland, have a handsome display of their productions at the Paris Exposition. Every detail of construction is exhibited, from the most elementary stage to the most absolute perfection. The exhibit contains watches of all sizes and all prices, from those of 6 line anchor escapements to the chronometer watches of 20 to 21 lignes, complicated watches of all kinds, hour, quarter and minute repeaters of 9, 10, and 12 lignes, and the finest mechanisms. The cases and the ornamental work of this rich collection are of the best taste. Their fancy watches also hold a prominent place. The observer admires a watch in the heart of a rose of diamonds, another in a narcissus of diamonds, a ring watch, etc.

—By July 15th, the new Hampden watch factory at Canton, Ohio, will be in regular working order. At this writing almost every effect is moved from Newport, Ky. The capacity of the new works is 2,000 watches per day. By the 15th, five hundred movements will be turned out daily, and it is anticipated that that amount will be increased to 1,000 within a year. The Hampden adjusted movements are to be furnished free of extra charge, in silverine movement holders with glass fronts, of the same general form as cases. This is to be done to avoid the liability to damage which adjusted movements are subject to when put in tin boxes for shipment; dealers can keep their adjusted movements in them, noting their rate until sold, thus avoiding the annoyance in taking a fine movement from its tin box, and finding it in bad order just at time of sale.

—The New York Standard Watch Co.'s new hunting movements are now ready for delivery, and are being forwarded on orders booked some time ago. All who have seen and examined it are pleased with its appearance and timekeeping qualities. Retailers, who can use a low price reliable movement, fitting any regularly made case, would do well to procure a sample from their jobbers. Both the open face and hunting are 7-jewel, straight line lever escapement. On application to the office, 13 John St., New York, a small pamphlet containing the opinion of a large number of practical watchmakers who have tested this movement. This company have also on the market a snap bezel and back open face watch. The case is made of special white metal, that has no plating to produce a bright surface. Frank G. Miller, the general selling agent, is highly pleased with the manner the retailers are taking hold of these movements.

—A unique, yet handsome design in alarm clocks that was introduced last week, represents a belfry and tower, the movement being set in the tower, and a good-sized bell to strike the alarm being suspended in the belfry. The frame work of this clock represents old unpainted boards, such as the conventional barn is made of. The whole is very handsome for a mantel ornament, and will, no doubt, sell well. It is made by the Wm. L. Gilbert Clock Co., whose New York office is in Murray street. The company are now carrying a good line of cuckoo clocks, and are displaying an odd and rather expensive mechanism in the shape of a "flute clock," at each hour, a figure of a Tyrolean yodler, coming out and playing a tune on a flute. This is, perhaps, the only clock of its kind in the country. By Aug. 15, the company expects to issue a new catalogue that will contain many new things in walnut and oak as well as fancy clocks.

—Visitors to the salesroom of the Ansonia Clock Company, 11 Cliff street, New York, can examine several new and pretty designs in fancy clocks; a unique one consists of three stacked rifles in bivouac, a small eight day clock, representing the drum, being suspended from their intersection; another represents a bicycle and rider, the clock movement being in the small wheel; still another represents the front view of a castle with turrets, etc., a mirror being in the center, with the clock above it. The company has just added to their stock lines of black marble and Mexican onyx clocks. The latter are made in thirty-five different styles of frame and with twelve styles of gilt dials. The latest novelty, however, is an elegant line of black marble clocks with bronze trimmings. The well-known Bee is now being made as an eight-day clock, and additional popu-

larity for it can be anticipated. Vernacularly, the "Jumper" is selling like hot cakes, which brings to one's mind the old query regarding pins, "Where do they all go to?"

—During the month thousand tongued Rumor was abroad spreading her chatter of an offer to buy the Elgin Watch factory by an English syndicate for the sum of \$8,000,000. The publication of the rumor in several daily papers caused quite a hubbub at Elgin, Ill., where it took the people by surprise. Both President T. M. Avery of the company, and E. J. Scofield, their eastern representative, denied point blank any foundation for the rumor, and asserted that the whole was a fabrication pure and simple. The figures that were reported as offered, alone, are so comparatively small that the report warranted immediate disbelief. The capital stock of the company is \$2,000,000, the assets showing the stock to represent 1,666 per share. It is natural to suppose that the stockholders are, under these circumstances, only too anxious to hold on to the shares. The report probably had its origin in the statement made at the annual meeting of the stockholders at Chicago that an agent of an English syndicate had asked President Avery what the factory could be bought for.

Many of the older and reminiscent portion of the trade will clearly recollect the genial figure of Victor M. Ramée, and will be grieved to learn that he died on the evening of May 19, in the town of Hackensack, N. J. He had been an invalid since 1871.

The deceased was truly a pioneer of the trade, having been intermittently associated with it from his youth until within a few years of his death. He was born in New York City in 1811, of French parents. After a short apprenticeship to a manufacturing jeweler he branched out for himself, continuing in business in New York until 1843, when he moved to Wisconsin to devote himself to farming and miscellaneous mercantile business. He returned East in 1852, establishing himself once more as a jeweler in Hackensack. In 1866 he formed a partnership with John R. Greason, under the style of Ramée & Greason, the firm doing business for five years at 25 John street, New York, when Mr. Ramée, owing to ill-health, was compelled to retire.

To recuperate his health he spent a few years in Yokohama, Japan, but very little benefit being derived from the sojourn he returned to Hackensack, where he remained for the rest of his days.

The deceased was of a genial temperament and was highly esteemed in his community. A widow, two sons and two daughters survive him.



The regular monthly meeting of the Executive Committee of the Jewelers' League was held on Friday, June 7th, there being present Messrs. Howe, Bowden, Bardel, Greason and Sexton.

Six requests for change of beneficiaries were granted. The death by drowning of Emil Young of Johnstown was announced and the Secretary was instructed to make immediate remittance for the aid of the family.

One application for membership was rejected; two were referred for investigation and the following applicants were admitted to membership: Caesar A. Cuppia, N. Y. C., proposed by Wm. Payne; Ira Emmet Pee, Indianapolis, Ind., proposed by Wm. H. Bradshaw; Otto W. Heineman, Philadelphia, Pa., proposed by Z. J. Pequignot and W. G. Blair; Henry Horwitz, N. Y. C., proposed by John R. Greason; Christopher Loeffler, Philadelphia, Pa., proposed by J. Rosendale and Geo. Osburn; Isidore Scooler, New Orleans, La., proposed by Wm. Bardel; Jewett W. Watson, N. Y. C., proposed by John W. Senior and J. J. Fogerty.

The Jewelers' Security Alliance

The regular monthly meeting of the Executive Committee was held at the Alliance Office on the 14th inst. There were present President David C. Dodd, Jr., Vice-President A. K. Sloan, J. B. Bowden, Chairman, Chas. G. Lewis, Treasurer, and Messrs. White, Butts and Stuart.

The following were admitted: Hans Guido, 1305 Lorimer St., Denver; Yale & Dillon, 17 South Main St., Gloversville, N. Y.; C. F. Mayer, 808 College Ave., Appleton, Wis.; John Best, 204 Market St., Paterson, N. J.; A. Wallenhorst, 17 South Gay St., Baltimore, Md., and Eli J. Boyce, 383 Washington St., Boston, Mass.

TABLE OF CONTENTS.

Accuracy of Certain Tools.....	77	Foreign Gossip	69	Leather Bracelets the Go.....	65	Rise in Diamonds, The	25
Advice to Watchmakers' Apprentices.....	65	Foreign Matters	33	Method of Demagnetizing Watches, A.....	34	Timing in Positions	66
Alessandro Volta.....	77	Glimpses of the Paris Exposition.....	26	New Optical Glass, The.....	66	To Lap Old Gold.....	71
Among the Diamond Mines.....	49	Gorham Mfg. Co.....	26	Obituary—Orin L. Coombs, Eben Cutler, 87		Trade Gossip.....	85
Around Boston.....	45	Meriden Britannia Co.....	29	Rice Sharpley, David Block,		Among the Watch and Clock Companies,	93
Attleboros, The.....	81	Leroy W. Fairchild Co.....	30	John Kleiser.....	82	Two Curiosities at the Paris Exposition	62
Chicago Briefs	37	Miscellaneous American Displays	31	Opening of the Dueber Factory	81	Welding or Soldering by Electricity.....	78
Communications.....	82	Gossip of the Month.....	21	Paris Gossip.....	41	What Waltham is doing for the Watchmak-	
Complete History of Watch and Clock		How often should a Chronometer be Cleaned	46	Proportion of Balances, The	66	ers of the World.—John Stark.....	59
Making in America—Watch Case Making	83	In the South	46	Providence Notes.....	42	A. J. Logan.....	53
Electricity and Magnetism.....	73	Jewelers' League, The.....	61	Quaker City, The.....	37	Workshop Notes.....	70
Fashions in Jewelry.....	57	Jewelers' and Tradesmen's Company, The..	83	Recent Patents.....	53		
" Art Glass and Ceramics.....	58						

INDEX TO ADVERTISERS.

Abry, Chas. Leo	80	Evans, W. F. & Sons.....	79	Lawson & Van Winkle.....	89	Scott, J. T. & Co.....	35
Acme Lever Button.....	88	Falkenau, Oppenheimer & Co., Outside bk cov.		Lelong, L. & Bro.,.....	outside back cover	Seth Thomas Clock Co.,	Inside front cov
Aikin, Lambert & Co.....	35	Fidelity Watch Case Co.....	56	Lorsch, Albert, & Co.....	Outside back cover	Sexton Bros. & Washburn.....	72
Albro, S. & Co.....	Inside back cover	Fisher & Sons.....	72	Mahler, E.....	37	Sheafer, W. H., & Co.....	52
Alvin Mfg. Co.....	44	Floyd, Pratt & Rounds.....	48	Mathey Bros., Mathez & Co	10	Shiebler, George W.....	12
American Waltham Watch Co	39	Foster & Bailey	48	McCall & Newman.....	76	Smith & Knapp.....	44
American Watch Tool Co.....	75	Fox, M. & Co.....	60	Meriden Britannia Co.....	13	Smith, Alfred H., & Co.....	23
Anti-Magnetic Shield & Watch Case Co..	17	Fowler Bros.....	27	Merritt, S. F.....	16	Smith B. & W. B.....	outside back cover
Atkinson Bros ..	71, 76	French, J. H.....	79	Middletown Plate Co.....	7	Special Notices	97
Arnstein Bros & Co.....	18	Friedlander, R. & L.....	16	Miller Bros. & Co.....	56	Spencer Optical Mfg Co.....	9
Bartholomew & Peckham.....	103	Froelich, H. & Co.....	18	Montgomery & Co.....	103	Sterling (The) Company.....	4
Beguelli, Tell A.....	96	Gorham Mfg. Co.....	20	Moore & Horton	76	Stern & Stern.....	6
Bedchimer, I.....	75	Grant, J. W. & Co.....	95	Myers, S. F. & Co.....	67	Stockwell, E. R.....	68
Berger, Albert & Co	10	Haldimann, E. A.....	18	N. Y. Watch Case Spring Co.....	97	Straus, L. & Sons	56
Birch, John S., & Co.....	96	Hamilton & Hamilton, Jr.....	36	Newman, Louis, Jr.....	103	Sussfeld, Lorsch & Co ..	60
Blackinton, R. & Co.....	36	HASKELL, H. C., - 18, 19		Newport Aluminum & Steel Co.....	56	Taintor & M: Alpine.....	88
Blancard & Co.....	72	Hausburg, O. E.....	103	Nicholson File Co.....	80	Tannenbaum, L & Co.....	60
Bookhout Bros	103	Hearn & Braltsch.....	12	Nissen, Ludwig, & Co.....	87	Taylor & Bro.....	52
Bowden, J. B., & Co.....	40	Hedges, A. J., & Co.....	87	Non-Magnetic Watch Co	28	Ternend, F.....	103
Braxmar, C. G.....	103	Hedges, Wm. S. & Co.....		Nye, Wm. F.....	104	Thrall, Edwin A.....	44
Bryant, M. B. & Co.....	80	Heinrich, H. H	36	Odenheimer & Zimmern.....	104	Todd, Ed. & Co.....	Outside back cover.
Buhler & Nanz.....	71	Howard, S. P.....	Outside back cover	Oppenheimer Bros. & Velth.....	67	Towle Mfg Co.....	35
Bynner, T. B.....	103	Howard Watch & Clock Co., E	91	Oppenheimer, Henry E. & Co.....	44, 64	Trenton Watch Co.....	92
Byrd, C. L. & Co	14	Hyde's Sons, John E.....	75	Ostby & Barton.....	68	Troemner, Henry.....	103
Carter, Sloan & Co.....	59	Illinois Watch Co.....	55	Owen, G. & S., & Co.....	52	United States Watch Co.....	24
Cattelle & Decker.....	43	Jacot & Son.....	43	Pairpoint Mfg Co.....	15	Van de Sande, Chas. & Co.....	19
Chalmers-Spence Co.....	71	Jacques, Charles.....	1, 75	Peterson & Royce.....	71	Valuable Instruction Books, Inside b'k Cover	
Champanois & Co.....	48	Jeandheur, F. Jr.....	60	Pforzheimer, Keller & Co	88	Wade, Davis & Co	68
Cheever, J. G. & Co.....	60	Jeannot & Shiebler	63	Pinnell, May & Co.....	18	Wallace, R., Sons Mfg Co.....	64
Chicago Horological Institute.....	87	Jewelers' & Tradesmen's Co	47	Plainville Stock Co	80	Waltham Watch Tool Co.....	16
Citroen, Vve. L. B., & Co	18	Kahn, L. & M. & Co.....	19	Platt, Chas. S.....	Outside back cover	Washburn & Moen Mfg. Co.....	103
Clark, A. N.....	79	Keller, L. H. & Co.....	96	Prindle & Russell.....	72	Watchmaker, Jeweler and Silversmith.....	96
Conover, D. F. & Co.....	2	Kendrick & Davis.....	79	Randel, Baremore & Billings.....	84	Waterbury Clock Co.....	1
Cooke, B. J's. Sons	75	Kent & Stanley.....	16 & 55	Richardson, J. W. & Co.....	15	Welch & Miller.....	36
Crescent Watch Case Co.....	39	Ketcham & McDougall.....	12	Riley, John A.....	87	Wheeler, Hayden W. & Co.....	40
Cross & Beguelli.....	19	Klüber, S. & Co.....	19	Riley-Osborn Mfg. Co., The	2	Whiting, F. M. & Co.....	8
Cottler, C. & Son.....	103	Klingenberg, A.....	88	Robert, J. Eugene, & Co.....	63	Wilkinson, C. B.....	103
Cottle, S. Co.....	55	Koch & Dreyfus.....	43	Rogers & Bro.....	11	Woglom, Gilbert T	76
Crouch & Fitzgerald.....	Outside back cover	Kohlbusch, Charles	103	Russell, Chas. A. & Co.....	Inside back cover	Wood & Hughes	52
Day & Clark	14	Krementz & Co.....	95	Russell, Irving L.....	88	Wood, Chas. F.....	72
Didisheim, Hipp.....	52	Lapierre, F. H. & Co.....	12	Sauter, L. & Co.....	52	Wood, J. R., & Son.....	103
Dorflinger, Chas. & Sons.....	24	Laurencot, J. B.....	Inside back cover	Schleicher, Schumm & Co.....	76	Zineman, M. & Bro.....	60
Dreyfus, Henry, & Co.....	3						

JEWELERS

VISITING NEW YORK THIS SEASON WILL FIND IT TO THEIR ADVANTAGE
TO INSPECT OUR LINE OF WATCHES, DIAMONDS AND JEWELRY FOR THE
FALL TRADE, WHICH

WE

CLAIM TO BE UNSURPASSED BY ANY IN THE MARKET. THE DESIGNS
ARE NEW AND EXCLUSIVELY OUR OWN, AND THE PRICES

ARE

GUARANTEED TO DEFY ALL COMPETITION.

STERN & STERN,

13 Maiden Lane, New York.



THE JEWELERS' CIRCULAR

AND

HOROLOGICAL REVIEW.

OFFICIAL REPRESENTATIVE OF THE JEWELERS' LEAGUE, THE NEW YORK JEWELERS' BOARD OF TRADE, AND THE JEWELERS' SECURITY ALLIANCE.

It is also the Recognized Exponent of Trade Interests.

A MONTHLY JOURNAL DEVOTED TO THE INTERESTS OF WATCHMAKERS, JEWELERS, SILVERSMITHS, ELECTRO-PLATE MANUFACTURERS, AND THOSE ENGAGED IN THE KINDRED BRANCHES OF ART INDUSTRY.

SUBSCRIPTION.—To all parts of the United States and Canada, \$2.00 per Annum, Postage Paid. To all Foreign Countries, \$3.00 per Annum, Prepaid.

All communications should be addressed to

THE JEWELERS' CIRCULAR PUBLISHING CO.,
189 BROADWAY, NEW YORK.

Advertising rates made known on application.



A full Index to Advertisements and Table of Contents will be found on Page 5 of this issue.

IN THESE days of undue and unbusinesslike competition, detraction and defamation form a goodly portion of the stock in trade of many salesmen, be they on the road or in the store. We do not believe that in the long run anything is gained by misrepresenting the character of the goods of a competitor. On the contrary, the most successful salesmen are those who candidly admit all that may be said favorable of the goods of another, thus establishing a reputation for candor and frankness, but continuing by showing the advantages of the articles they have to sell. If a merchant in any line of trade should arrogate to himself all the commercial integrity of that line; if he should deny to others the merits of simple honesty; if he should claim to have the best stock and to sell at the lowest figures; if he should in divers ways assert his superiority to all others, his modesty would speedily be at a discount and his motives open to suspicion. Beside laying himself open to suspicion by such assertions he gratuitously insults the intelligence of those with whom he converses. Buyers are not idiots, and they are very apt to judge one somewhat after the fashion that he judges others, so that when salesmen pick flaws in the reputation of a competitor their hearers immediately begin to look for the vulnerable spots in their armor.

If goods cannot be sold upon their merits they are not worthy of being in the market, and buyers are getting tired of this continual depreciation of competitors. We hear complaints of this kind from all sources, and we would suggest to all persons identified with the trade that it never pays to attempt to build up their own reputations by pulling down those established by their neighbors.

**

**

**

"Electricity and Magnetism," by EXCELSIOR, a most valuable series of articles for the watchmaker, is still continued. Worth a year's subscription.

**

**

**

A PARISIAN contemporary, the *Moniteur de la Bijouterie et l'Horlogerie*, commenting on the silverware display in the American section of the Exposition, offers some criticisms, which for their general truth and candor will bear translation. Speaking of the goldsmith's work of Tiffany & Co., the editor says:

"If I dared to express my opinion on the matter, I should avow that this is just the part that pleases me least. Certainly there are handsome pieces, of an exquisite workmanship, rich, artistic, and even exaggerated in decoration. All of these things, however, will not succeed in hiding to the eyes of the connoisseur the fundamental vice of manufacture, namely, the poverty of design, the want of proportion, the absence of harmony between the different parts of a whole. Let them be compared with similar products exhibited in the French sections of goldsmithing and jewelry. Here we find what we vainly seek in the American section—that is to say, more simplicity, more design and less ornamentation. Refined though the taste of Americans has become already, it is far from joining perfect art and science innate of the form which has given to Paris the superiority over the entire world in all branches of artistic production."

Without taking issue with the *Moniteur* on the particular application of these strictures to the exhibit of Tiffany & Co., we must confess that as regards our present stage of art development there is much truth in them. Organic art is a product of slow growth. Symmetry, harmony and proportion are among its fundamental laws. Ornament or embellishment is of secondary importance. Yet this last is almost invariably exalted above the other by the uncultured judgment. Tried by the principles of art, much of the work, both in gold and silversmithing, that now passes current among us, is seen to be defective. It is heterogenous, lacks harmony or organism, as the critics express it. For this fault of immaturity there is but one remedy—education, the development of taste through the permeation among our people of the spirit nurtured in the art schools that are now springing up here and there. This is the only corrective for the amateurish, prentice-like style which we now seem to affect. Thoroughly trained and capable artist-artisans, imbued with the love of their calling and grounded firmly in its principles, will, by the work of their hands and brains (for brain and hand will work together), put models before the people that shall fulfill the eternal laws of beauty. Year by year, then, unconsciously will the national

taste correct itself, until with genuine artists as leaders the people themselves shall become no mean adepts in connoisseurship. It is for this reason, and further because we recognize the commercial value of true art applied to manufactures, especially such as the jewelry and kindred trades, that THE CIRCULAR has from the outset avowed itself a friend of the art school and a firm believer in its saving mission.

*

**

THERE is no question that the retail trade has been pretty well canvassed by the representatives of manufacturers and jobbers, and that competition has lead buyers to look upon the traveling salesman as almost "too frequent," if not too previous. At the same time, buyers do not always act with that frankness and candor that ought to characterize a business man. When not desiring to purchase goods they are very apt to give to the traveler excuses that are, to say the least, extremely gauzy. For instance, a traveler for a well-known house in the Lane returned recently from a trip and reported that his goods did not seem to go very well, and added the remark that if he had had the line of goods sent out by a competitor he could have sold them "like hot cakes." The salesman of this same competitor made precisely similar reports, that in this dull season they could sell but few goods, but if they had had those of the other house they could have done a good business. This is one of those flimsy excuses that retail dealers are in the habit of using to get rid of the salesman who is soliciting their orders. A dealer does not want any goods that are shown to him, but but he has not the courage to say so promptly, but alleges that something else of somebody else's make is what the public wants, and so from one excuse to another. He has been a fortunate salesman during the past few months who has been enabled to make a favorable report upon his trips. There is no use of prevarication in a matter of this kind. If a man does not wish to purchase the goods shown him he ought to be courageous enough to say so frankly and with sufficient decision to convince the traveler that he wastes time in talking with him. Such a course would save both the traveler and himself much annoyance and valuable time. Why will not business men see that the straightforward, businesslike way of dealing with every subject presented to them is the only true and manly course for them to take, and that beating around the bush is only a subterfuge easily seen through and reacting ultimately to their disadvantage.

*

**

Call the attention of editors of your local papers to "Elsie Bee's," "Rambles Among the Jewelers," and have the items reprinted. It will increase your trade.

*

**

THE Secretary of the Treasury's report on imports and exports for May contains the following items of interest to the jewelry trade: Imports of rough and glaziers' diamonds, 1888, \$30,588; 1889, \$14,050. Imports of clocks and clock materials, 1888, \$27,586; 1889, \$24,549. Imports of watches and materials, 1888, \$130,237; 1889, \$124,963. Imports of jewelry, 1888, \$68,109; 1889, \$62,948. Imports of precious stones, 1888, \$1,188,859; 1889, \$955,712. Exports of clocks and clock materials, 1888, \$93,242; 1889, \$105,199. Exports of watches, 1888, \$43,879; 1889, \$22,700. Exports of jewelry, 1888, \$34,681; 1889, \$66,425. Exports of plated ware, 1888, \$56,147; 1889, \$56,521. There is a decided falling off in nearly every article, jewelry as export being about the only one that shows a decided and encouraging increase. For the eleven months ending May 31 the increase in exports of this commodity was nearly 100 per cent. This would seem to indicate that our manufacturers are beginning to look up neglected opportunities for foreign trade and are finding the venture a profitable one.

FREQUENT inquiries are received at the office of THE CIRCULAR for Excelsior's "Treatise on the Balance Spring." This valuable work is unfortunately out of print, but if there should appear on inquiry to be sufficient demand for it, another edition will be struck off. Those who are desirous of procuring it are requested to send in their names, as also any having copies they wish to dispose of.

*

**

"Welding or Soldering by Electricity," page 78.

*

**

WHILE treating of the subject of design in jewelry the question arises, whether much of the complaint we hear about excessive competition in the plated line is not due to poverty of design. Mere mechanic labor and cost of raw material are easy to compete against; not so, the captivating beauty which the skill of the designer can give to an article of use or ornament. In an Atlantic seaboard city are two potteries, one old-established house, wealthy and conservative, another younger, more energetic, and more alive to the commercial value of art. The proprietor of the former cannot understand why his competitor gets almost double the price for what he is pleased to think are the same goods. During a recent conversation this younger rival explained to him that beauty is what people pay for in wares of that kind. Said he: "I exercise my ingenuity in the devising of tasty and novel designs constantly while you ignore the element of beauty altogether. You are paid simply for labor and your capital invested, I am paid for my brains." This, it seems to us, is the condition that prevails among many of the manufacturers of plated jewelry. They ignore the element of design altogether, fall into monotonous stiffness in their styles, copy-gold patterns or repeat themselves wearily year after year. Is it any wonder that they complain of the ruinous effects of such a policy? On this dead level of dullness any workman with a hundred dollars and ordinary knowledge of his trade can become a competitor. But there is a higher level on which a manufacturer may become in a sense above competition because he is individual and original in his styles. Goods that are used for ornamental purposes must have something besides cheapness to recommend them. There is no reason why a piece of plated jewelry should not be durable and artistic in design, and if the makers of such jewelry have a regard for their own interests they will confine their production to reliable goods such as consumers can recommend. Business men who count too much on the ignorance and credulity of the public are almost sure to meet with deserved failure in the end. It is far better to manufacture for a public that knows how to appreciate merit and is willing to pay for it. You will find that public if you persevere, and it will reward you.

*

**

OUR Chicago correspondent informs us that one of the fashionable retail jewelry stores of that city is adding to its stock an assortment of elegant satchels and traveling bags with silver mounts. This is only another instance of the versatility the modern jeweler is capable of. Obedient to the demands of the times, leading jewelers all over the country are making their stores headquarters for all sorts of luxuries in the decorative line, so that customers find it convenient to make much more frequent calls than they would if jewelry proper were the only thing dealt in. The modern tendency to centralization in business cannot be ignored. Neither can the laws that govern the actions of men, and one of the most obvious of those laws is that men are disposed to satisfy their wants with the least possible expenditure of effort. Consequently, if a half-dozen articles which a man wants can be purchased at one place and the time and exertion of further seeking saved, other things being equal, he will go to that place for convenience sake. It will be seen at once therefore, what

an advantage it is to the jeweler from this point of view alone, to diversify his stock by the constant addition of novelties in art pottery, cut glass, bric-a-brac, fancy leather and the numerous other "things rich and rare" that the market is continually affording, taking care, only, to maintain his position as a purveyor of the choicest and most artistic grades. If he is handling the same goods that other trades do, his assortment should be so select, so exquisite and unique, that competition between them will not be keenly felt. The first-class jeweler ought to have at least a share of the wealthy patronage of his town, and he must be a leader in taste if he expects to retain his prestige.

* * * * *

Read "Two Curiosities at the Paris Exposition," on page 62.

* * * * *

The many readers of Dr. C. A. Bucklin's articles will be sorry to learn that owing to the doctor's illness it was necessary to omit the regular instalment on "Mechanical Ocular Defects" from this number of THE CIRCULAR. That his illness will not prove of such a serious nature as to prevent him from taking up the thread of his story in our next, is the wish of THE CIRCULAR and, we feel sure, of our many readers who receive pleasure and instruction from his pen.

* * * * *

"Art Glass and Keramics"—a new department—will help you in buying your fall stock.

* * * * *

WE ARE indebted to our esteemed contemporary, the *Manufacturing Jeweler*, for a copy of a new directory of the jobbing trade of the United States and Canada, entitled, "The Wholesale Jeweler, 1889." It is evidently complete and will do good service as a work of reference.

* * * * *

AT THE preliminary meeting held in Mayor Grant's office on the 25th ult., to organize for the World's Fair of 1892, the mayor expressed a wish that the various trade organizations of New York city meet and appoint committees to represent them in the work of preparing for the great event, and report the lists to him for approval. So far as we know no steps have been taken by either the Board of Trade or the Jewelers' Association to this end, but those organizations should immediately take joint action in the matter. Representative men from both bodies should be selected to receive the mayor's official approval at once. The jewelry trade ought to take a leading position in this movement, and we feel certain that it will.

* * * * *

"The Paris Exposition"—description of some of the chief American exhibits in the jewelry section, continued.

* * * * *

THE CIRCULAR acknowledges the receipt from the Baker & Taylor Co. of a very instructive little book on "The Art of Selling: with hints on good buying, etc." by F. B. Goddard. The book is full of good hard common sense advice to those who wish to perfect themselves in this important art. After considering the changes in commercial methods which have led to the rise of the commercial traveler, the writer enters into the rationale of selling goods, and treats us to a very entertaining mixture of philosophy,

phrenology, metaphysics and morals, so that when we finish the book we are constrained to believe that the successful salesman of to-day must be more than human in his many excellencies. Literature of this class is multiplying to add further testimony to the growing importance of the traveler in the commercial sphere. Salesmen will find both pleasure and profit in perusing this book.

The Rise in Diamonds.



URING the past month the absorbing topic of discussion and speculation in the jewelry trade was the advancement in the prices of diamonds. The representative of THE CIRCULAR, hearing on all sides the pros and cons of the subject eagerly dissected, was led to interview a prominent diamond dealer, who had just returned from his annual European trip.

"I think," said this importer, "that what your Kimberly correspondent says in his letter respecting the DeBeers, Kimberley Central, Bulfontein, and Dutoitspan Diamond companies is true. These companies have consolidated their interests, the Bulfontein and Dutoitspan having been offered a guarantee of 4½ per cent. per annum on their capital stock to join the combination. This I think, has been effected more for the purpose of reducing the expenses in mining and for the establishing of a steady market, than for any such reason as creating a corner in diamonds.

"The whole cause for the present advance, may be seen by studying the condition of the existing mining operations. Diamond mining is monthly becoming more and more difficult. You may know that these operations are quite different from those of coal, iron, etc. Bevelled excavations are made from the surface of the field down to the Blue Earth in which diamonds are found and the space is increased by constantly encroaching upon the walls. You will perceive that sometime or other, the limit of the field must be reached and the walls become so steep that thousands of tons of reef that have been left from past operations, are caused to fall on the mining ground. These falls are attended with loss of life and the removal of the debris to uncover the blue ground is very expensive. All the mines suffer more or less from these falls. The Bulfontein and Dutoitspan having reached the limits of their fields, and owing to threatened increased falls of reef, must either suspend operations, or adopt expensive underground methods. The supply is not exhausted, but lies unobtainable. The consolidated DeBeers have now sunk shafts and are operating in tunnels, leaving pillars of the blue ground to support the roof. This has proved an uncertain method owing to the disintegration of these pillars on exposure to the atmosphere. The Kimberley Central have had much trouble from this cause. These falls of reef and disintegration being frequent and costly, it is no wonder the supply has decreased during the last few months. So by this consolidation of interests, new and expensive methods can be adopted, and the smaller companies can share in a measure, a dividend that they have long been struggling for.

"The advanced prices are undoubtedly the result of the consolidation. Rough is 15 to 30 per cent. higher than it was two months ago. While in Amsterdam, I noticed that some 40 or 50 cutting establishments had shut down; prices of rough were so high in London that the cutters could not realize for their finished goods as much as they cost them. But the suspension will last only to such time as prices become assured, which I think will be within a couple of months. Some cutters are to-day cutting stones heavier, thicker and in every way inferior in order to keep the price down. They save between 45 to 50 per cent. of the rough, while in good cutting 37 is an excellent percentage.

"The outcome of the whole agitation, I think, will be a stiffening of prices and a steady market; no doubt before the end of the year a new standard of higher prices will be reached and maintained."

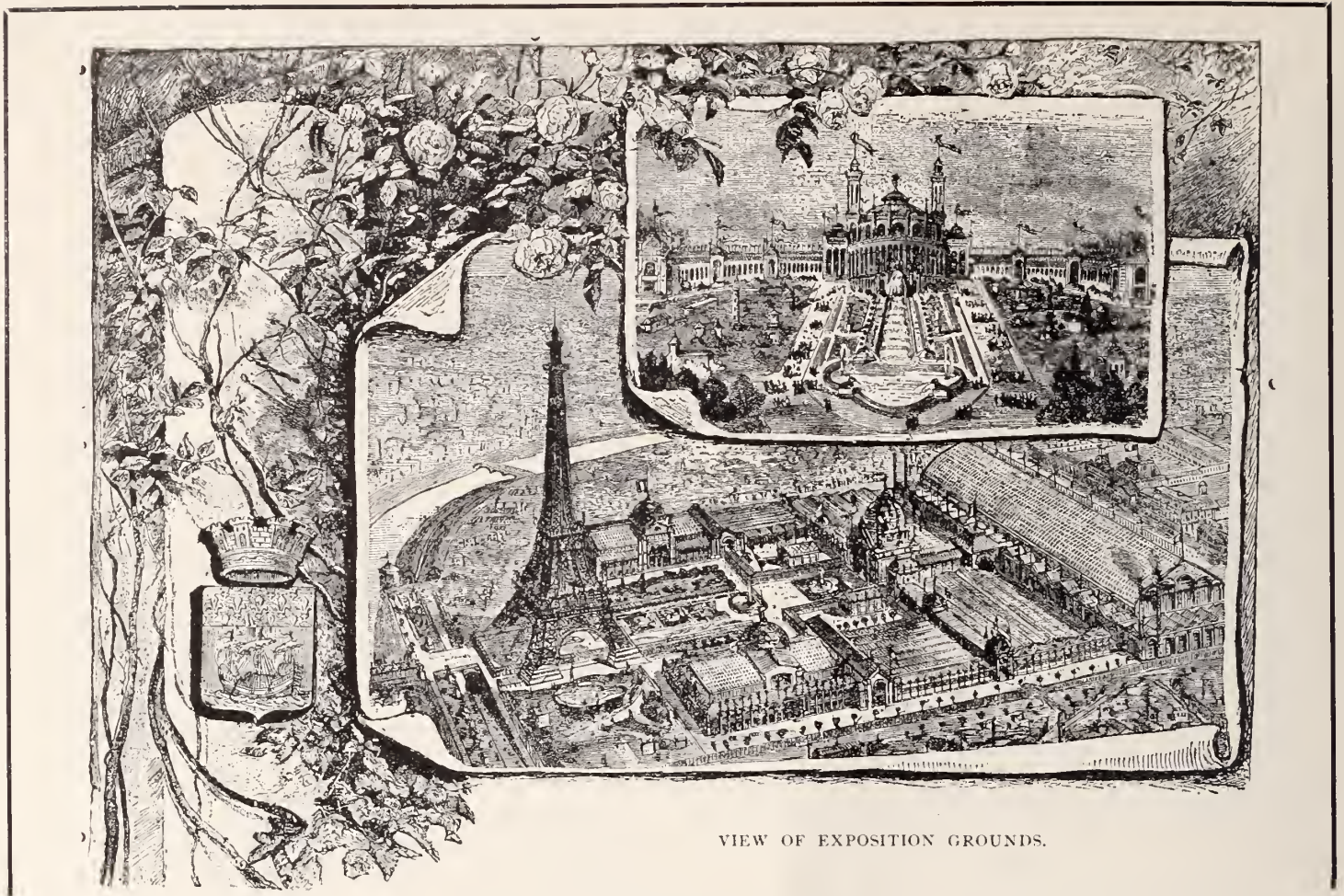

VIEW OF EXPOSITION GROUNDS.

Glimpses of the Exposition.

PARIS, July 15th, 1889.

THE GORHAM EXHIBIT.



THE GROWING success of the Exposition is a fact, and all participants in it will obtain results by far superior to what they might have dreamt of. The terrible predictions of the political prophets, Von Bismarck, Tizza, and Crispi, have been set at naught by something better than words, viz. : industry and art ; and people who may have come timidly to Paris, with a vague fear of being ill-treated, soon alter their opinions of us, and lengthen their stay in the French capital far beyond the limits they had previously assigned to it. It is true that all has been calculated to render the Exposition thoroughly attractive. Besides the enormous variety of articles or products exhibited in the numerous sections of the main buildings, there are, in the grounds numerous pavilions of different sizes and architecture, some of which, made of assembled iron parts elaborately adorned, will be sent to South America, when the great competition meeting is over. Everywhere there is something interesting to see. If you are tired of inspecting goods and works of art, you may take a rest at the Roumanian Café, or the Hungarian, where a sweetly peculiar music will enchant your ears. Or you may take a stroll in the street of Cairo, where all kinds of original shops will offer you a varied distraction, unless you should prefer paying a visit to the Japanese, or the Persian, or the Chinese, or the Indian places. Then, if the Champ de Mars and the Trocadero, which is on the other bank of the Seine, are not enough for you, take the Decauville train near the Eiffel tower, and ride off to the Esplanade des Invalides. There if the Javanese, Cochinchinese, Tonquinois, Annamites, Cambodians, Congolese, Algerians, Tunisians, etc., all native, with their peculiar exhibits in original palaces exactly reproduced, fail to interest you, even with their plays, ballets, conjuring performances, ceremonies, etc., then you will find nothing on earth likely to awaken your curiosity.

Let us describe a few of the Gorham Mfg. Co.'s most striking pieces :—The tea set in the Louis XVI. style with a happy introduction of figures among the ornaments has a charming effect. There seems to be real life in those nymphs and cupids, moving out of the conventional foliage and shrubbery. The attitudes are graceful and the features fine. In point of execution the set is perfect. A waiter of an original outline is a remarkable example of chasing in low relief. A candelabra, in the same style, is beautifully modelled and chased in all its parts. Another one, of an Indian design, resting on the back of an elephant, is most original. It is finished off in old gold and oxidized silver.

A set that attracts a goodly amount of attention and excites numerous exclamations and remarks of admiration is a charming Japanese tea service consisting of eight pieces, two of which, the coffee and cream, are elegantly illustrated herewith, and decorated with Japanese figures in *repoussé*. The other pieces are the waiter, kettle, tea, sugar, slop jar and tea caddy. The whole set is in remarkable contrast to the surrounding beautiful objects in style of decoration and execution. In describing the set I fear I shall commit the error of employing a redundancy of adjectives, for too much cannot be said in praise of this magnificent service. The tray or waiter is an effective example of decorative color engraving ; it represents a Japanese landscape, showing water, mountains in the distance, pagodas birds, foliage, etc., all finely represented in etched work, the effect being much heightened and enlivened by the employment of gold in combination with the oxidation, thus faithfully following the Japanese idea, which conceives the use of gold in most every work of art and skill, and forming a picture as artistic as if it was executed with a brush or pen.

We note that in proportion, perspective, outline, and execution, the objects in the landscape are distinctly and essentially Japanese.

The design of decoration is different in each piece, though all represent natural Japanese scenes and objects, faithfully executed and true to the model. The effect of each piece is beautifully heightened by a judicious employment of gold and colors in combination with the engraved ornamentations. The native stork, with its conventional but characteristic surroundings of water, foliage, etc., is depicted gracefully and naturally on one piece; on another are delineated two figures in their native habits; on another is a Japanese coolie, laboring under the weight of his water-carrier, while on the others are delineated dragons, flowers, butterflies, etc., all characteristic of the country and charming and interesting portrayals. On the lid of the tea is a modelled ornamentation of a frog; on the coffee, a dog; on the kettle, a large specimen of native fruit with its leaf; all are faithful to the life and are charming in effect.

The principal mounts and handles represent dragons of different character, some having human heads while their bodies are those of serpents; some are winged, while others are taloned. Thus it will be seen that the amount of detail in each piece is remarkable; one never seems to end discovering new points of beauty and admiration; one inspection is not sufficient, nor can a description such as this convey a complete idea of the beauty, originality, fascination and charm of the reality. We regret space will not allow a fuller description and illustration of this set, which, however, must be seen, and seen more than once to be thoroughly appreciated. A point worthy of remark, and one that will convey an idea of the artistic excellence and quality of the Gorham Company's productions is, that this magnificent service was not made especially for the exhibition, but was taken from the stock.

The *repoussé* coffee set in modern American style is very elegant. The pieces are finely wrought and bold in their outlines. The cups sweetly pretty, seem to spring up from their saucers. The floral ornamentation on the coffee pot is treated with a remarkable gracefulness. Those velvety petals exhibit gentle curves true to nature, and the relief, well managed everywhere, while subdued in some parts prominent in others. The whole service bears the mark of a hand thoroughly experienced and skilled.

The toilet set in the rococo style is simply lovely. All the shell fragments and sprigs of flowers seem to ripple as if under the influence of an inspired breeze (if I may be allowed to speak thus). There is something unfettered, out-flowing, yet symmetric in the ensemble. All the parts seem to turn to opposite directions and yet they all meet and assemble in perfect harmony. Playful little cupids introduced here and there make the effect still more charming. The mirror which accompanies this set is a master piece. Its design, modelling and chasing are of such a superb character as to be unsur-

passable by any other artist. All visitors are and will be of the same opinion.

Also of superlative beauty is the tea service, consisting of six pieces, the tea of which is depicted on this page. The service partakes of a pronounced oriental feeling, while its treatment is East Indian. The several pieces are massive and unusual in character, the designs, as in the Japanese set, varying distinctly in each piece, while a general harmony between all the adornments prevails. The body of each consists of chased vertically curved shallow flutings, the curves being most perfectly and delicately executed. In each of the sides is executed in high relief a bunch of flowers, a species of the rose, with their leaves, harmonizing sweetly with the flutings, and enhancing greatly the beauty of the whole. Four similar bunches, though much smaller, occupy an intermediate position, and form the corners of an imaginary square about the larger bunch. The flowers in each piece are different, but equal in beauty and excellence of workmanship. The top decoration below the lids is elegant; it consists of a circle of overlapping flowers, looking, in their half developed character, like



TEA OF EAST INDIAN TEA SERVICE.

exquisitely delicate shells. The effect of this high relief ornamentation is elegant. The spouts of the pots and the socket for the handles are bright finished. Altogether, the service is an elegant example of artistic manipulation

THE MERIDEN BRITANNIA CO'S EXHIBIT.

The silver plate exhibit of the Meriden Britannia Co is one of the finest ever seen, and includes the whole range of goods desirable in that line. Among their capital pieces, visitors at once remark The Indian on Horseback Fighting a Buffalo. That group is full of life and all the attitudes are true to nature. It is finished as a work of art and is worthy of any museum. Several punch services for twelve people are also very much admired. One of them rests on a large stand with wide festoons all round the outline of the base, thus forming twelve separate and regular places occupied by the cups. The bowl rises gracefully on the center and on its cover is a pretty figure on tiptoe. There is also a grand sur-tout, of an original style, deserving a careful inspection. It is one meter high and 75 centimeters long.

The exhibit contains a great variety of elegant and original models. If we only look at their mirrors, it will be difficult to know which to admire the most. Here is a square one bordered with pearls (No. 9932) of a Louis XVI. style; it has a cherub at the top (in a half-soaring attitude) holding up a drapery, while two other playful infants are seated, restlessly, one on each side of the case. Other triplicate mirrors, from 16 to 25 inches in height, show different decorations done in etching, *repoussé* and chasing; most of them are in old silver and some have gold inlaid. A very original one (No.



COFFEE AND CREAM OF JAPANESE TEA SERVICE.

soaring attitude) holding up a drapery, while two other playful infants are seated, restlessly, one on each side of the case. Other triplicate mirrors, from 16 to 25 inches in height, show different decorations done in etching, *repoussé* and chasing; most of them are in old silver and some have gold inlaid. A very original one (No.

9931) has a figure of a negro female, who laughs with a broad grin, standing at the back. Her hands rest on the top of the frame; an arrow is in the right one.

The fruit dishes are all very handsome. I especially remarked the one with a dog on the stand. Partly hidden underneath a kind of cover from the partridge or grouse, which he is spying, he stretches his head forward toward his prey. The subdued excitement of the animal, and his impatience to run, denoted by the curled foreleg are perfectly rendered.

They have a great variety of tilting pitcher sets with goblets and slop bowls. I particularly admire the one in embossed old silver (No. 76), 21 inches in height, with a figure standing on each side. It is a graceful female whose fine features and elegant arrangement of hair remind one of the celebrated Diane de Poitiers, as immortalized by Jean Goujon.

With the description of all the other items such as muffineers, tureens, lamps, candelabras, spoons, forks, knives, napkin rings, toilet sets, razors, pocket flasks, etc., I could fill up many pages. I must be contented with saying that all those pieces are beautifully treated and look very attractive. I propose, however, to forward you full descriptions of several other pieces in due time for the September issue, in which you will afford space for illustrations to several of the articles in this company's exhibit.

LEROY W. FAIRCHILD CO.'S DISPLAY.

What a pretty stand is that of the Leroy W. Fairchild Co.! Every passer-by is bound to stop before it and admire its many points of beauty. The pleasant contrast of white and gold settings and coverings makes it exquisitely charming. Visitors cannot resist the fascination of minutely examining the contents of the large case



FLASK.—(ONE-HALF SIZE).—L. W. FAIRCHILD CO.

whose frame is of solid brass, with a light yet elaborate ornamentation running along the base.

The exhibit occupies a space 10 x 10 feet. The table on which the case rests, as seen in the illustration, is nine feet in length, while the case itself is eight feet. The goods within the case rest upon soft black velvet, a material well calculated to set off their beauty. The case is divided into three parts; in the left-hand portion, the observer looking at the case, are gold pens, penholders and pencils;

in the right-hand portion are silver novelties and pocket knives, corkscrews, cigar cutters, cigarette cases, match boxes, flasks, whistles; in fact, all varieties of small ware adapted for pocket use; and in the center department are small wares and pencils in solid gold, and gold in combination with platina.



MATCH BOX.—(FULL SIZE).—L. W. FAIRCHILD CO.

The pencils make a fine array, and among them are discerned some of exquisite loveliness. Almost endless in variety of design, the observer discovers some item of originality and beauty in each piece. Charming to the vision are some in worked gold; others in gold and platina gracefully intertwined; while others are gorgeous with gem decorations, consisting of diamonds, pearls, rubies, sapphires, etc.

Among the match boxes in gold and silver are seen some containing enameled paintings, sweetly pretty. One, an illustration of which is given in this article, is decorated in Florentine scroll-work style, which, combined with its peculiar outline, makes it a very attractive article. This box is made by the firm in both gold and silver, and is design-patented. A box whose gorgeousness almost takes one's breath away is of gold in cable pattern, the surface being a veritable net-work of diamonds, set in the convex curves of the ribs. It is priced at \$1,000.

The flask, of which a half-size illustration is given, is of sterling silver, bright and oxidized. The front represents two partially nude female dancing figures, perfectly executed, in bright relief. They stand out from a black oxidized ground, and surrounding them are elegant specimens of chased scroll-work, very pleasing in effect. The reverse or back of the flask is of clear bright silver. The whole is strikingly handsome, and should satisfy the taste of the most fastidious. Then there is the same design made in solid gold.

As to the small wares, they are decorated in all possible styles—engraving, chasing, *repoussé*, enamel, miello, etc., and many are tastefully studded with gems. The variety of the pieces is too numerous and the beauty almost too equalized to allow an attempt at mentioning of any special object.

The execution in every piece, pencil, box, case or flask, is so fine and perfect that if examined through a microscope a real pleasure would thereby be afforded.

In the panel on the left hand side of the case, set in a background of black velvet, are fifteen medals awarded the firm at numerous exhibitions during the past forty-five years. All of these are first prizes, received at the following competitions: New York American Institute, 1847, 1848, 1849, 1850, 1853, 1876, silver, gold, silver, gold, silver, silver medals, respectively; Paris Exhibition, 1867, 1878, bronze and gold respectively; Vienna, 1873, bronze; United States Centennial, 1876, bronze; Sydney, 1877, bronze; Adelaide, 1881, gold; New Zealand, 1882, gold; World Industrial and Cotton Exhibition, 1885, gold and bronze.

Already many foreign orders for duplicates of these Exposition

goods have been received at the New York office. But in few cases is it necessary to manufacture them, as most of the goods displayed at the Exposition have been taken from the stock, and are but samples of lines constantly carried.

gem. This and other pieces will, no doubt, place American glass at least on a level with that of the long known continental houses. What to say concerning the Rookwood Pottery, or rather where to stop speaking, is a question that puzzles me. Nearly all that portion

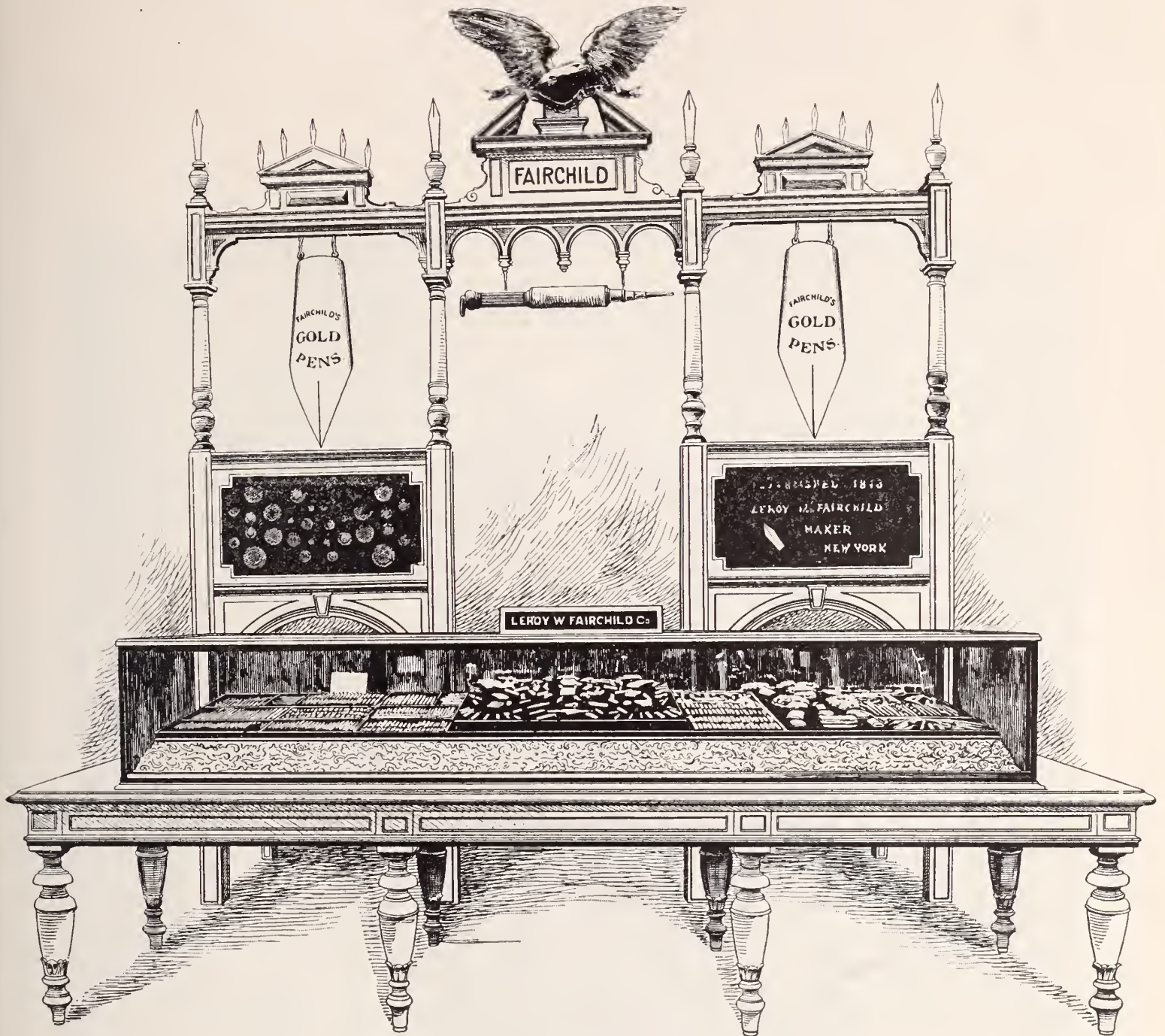

THE DISPLAY OF THE LEROW W. FAIRCHILD CO.

I must really return to the United States section and give you more details about it. The Meriden Britannia Co., on one side, and Davis, Collamore & Co., on the other, occupy with the Gorham Mfg. Co., and Tiffany & Co., the four important corner places formed by the intersection of two wide alleys crossing each other so as to divide the whole court into four equal parts. Those *privilegiés* exhibitors develop their displays on so extensive a front that visitors can almost obtain a thorough idea of it from the outside. Yet they never fail to enter those places, attracted by an inviting arrangement which gives them the appearance of elegant and comfortable salons.

MISCELLANEOUS AMERICAN DISPLAYS.

The exhibit of Davis, Collamore & Co., is like a fairy palace in which fair visitors forget all about flying hours. The admiration of by-goers is won at once by a large punch bowl, 18 inches in diameter by 14 in height. It is supposed to be the largest cut glass bowl in existence, and being of the purest white, it sparkles like a gigantic

of the exhibit is already sold, and will, at the close of the Exposition, take different roads leading to all parts of the globe. A vase of a dark red on which in slight relief a branch of berries stand out, the leaves of which are most gracefully folded, has been bought for the *Musée des Arts Décoratifs*, Paris. A curious vase of an elongated shape, 12 inches in height, is of Japanese treatment, and shows a conventional daisy decoration, on a background of mahogany and yellow, beautifully painted. It is of the rich appearance native to the skin of a fine pear. That piece has been purchased for the Royal Worcester Museum.

The other American exhibits of interest to your readers, those of the Trenton Watch Co., Waterbury Watch Co., Kent & Stanley, H. H. Heinrich, J. F. Fradley & Co., W. F. Gardner, etc., are now in order, and I will forward you in due time for your September issue, full descriptions and photographs of them. Meanwhile I content myself with a brief sketch of each.

Tiffany & Co.'s jewelry is more and more admired. I described you some of their pieces in my last article, but I wish I could place them graphically before your eyes. Ordinary illustrations without the advantages of colors, cannot do justice to the different pieces. The various hues of those lovely stones have been so skilfully opposed that they must be shown exactly as they are, or the effect is sure to be weakened.

The Trenton Co.'s glass case is neatly arranged. An hexagonal column covered with blue marine velvet rises in the center, and on it are hung gold and silver watches with cases decorated in etching, engine turning, etc. I need not speak of the quality of the watches as they are too well known in America.

H. H. Heinrich exhibits several chronometers, with self-adjusting compensation weights and isochronic regulators. The perfection of these timepieces is too well established to require any insistence of the fact in any part.

The gallant king, represented in profile in a medallion and surrounded with garlands of fruits and flowers, is shown by the artist at his very best. The crown and the sword of the popular ruler are placed at the base of the frame, which fact may be a sufficient excuse for my description of the aspect in *THE CIRCULAR*. All the floral details appear as though they had been painted in the most nature-imitating colors. The sky-blue scarf worn by the king and the metallic appearance of the breast armor are perfect in execution. I think the beautiful illustration reproduced in this article gives a very striking idea of that fine work.

The Prince of Wales and family spent a whole week in Paris and went to the Exposition every day. The section of the United States was favored with a special visit and its central exhibits examined with deep interest.

The foreign members of the jury of awards for gold and silver-ware are: J. Schieb (U. S.), Chopin (Russia), Baron Delort de

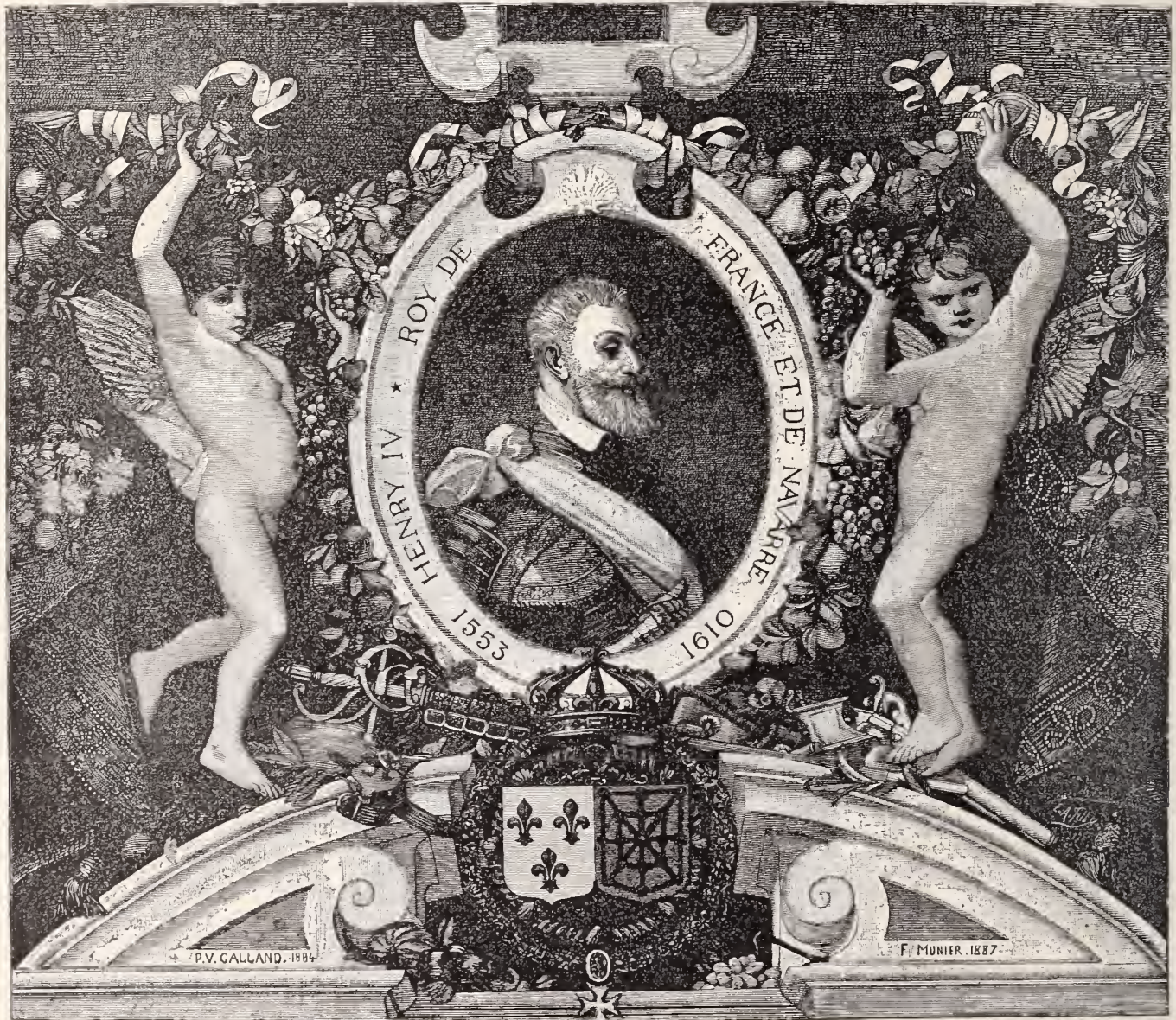

GOBELIN TAPESTRY, DESTINED FOR THE GALERIE D'APOLLON.

The Waterbury Watch Co.'s pyramid covered with 2,296 watches attracts attention from the very moment you enter the American Section, although it is placed just outside the further end.

Kent & Stanley's exhibit of seamless filled gold chain is well placed to attract attention, and the articles are neatly and invitingly arranged on a deep blue velvet background.

J. F. Fradley & Co.'s display of fine gold-headed canes, in embossed work of various styles, is very tasty and strikes almost a dazzling effect on the passers by, who cannot help approaching the glass case to examine the various articles in it.

I can hardly be accused of stepping out of my limits if I mention one of the Gobelin tapestry works, exhibited near the circular balcony, glittering underneath the resplendent cupola. I mean the one with the portrait of Henri IV. of France, destined for the Galerie d'Apollon, at the Louvre, where all our historical jewels are preserved.

Gléon (Egypt), Krog (Denmark), and Dru (Siam). The French jurors are: Odier, Falize, Chenaillier and Poussiégné-Rusand.

The success of the Exposition, which has been very great from the first, is daily increasing. On holidays the amount of paying visitors very often exceeds 250,000, and although the buildings and the grounds occupy a much larger space than ever was covered by any previous Exposition, people are in some points thickly crowded.

This is hardly the place to describe the fête of the 4th of July. All I can say is that the impressing speech of Whitelaw Reid, and Dr. Chautemps' answer, associating the names of Washington, Lafayette and Rochambeau, were warmly welcomed on both sides. American exhibitors and French people, in the presence of President Carnot, exchanged most heartfelt wishes for an enduring friendship, which can easily be established between two nations that enjoy the blessings of freedom.

FRANCUS.

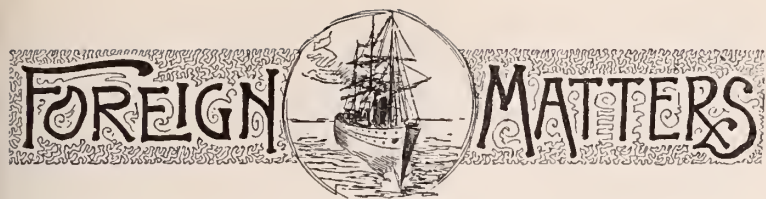

[FROM OUR SPECIAL CORRESPONDENT.]

TRADE IN THE HEIGHT OF THE TOURIST SEASON.—PRIZES AND PRESENTS IN VOGUE.—MRS. GLADSTONE SETS A PRECEDENT, AND PINK CORAL WILL BE A FAVORITE.—ALL WEDDING RINGS TO BE HALL-MARKED.—A NOTABLE AUCTION.—VALUE OF OLD ENGLISH PLATE.—RUBIES IN THE ROUGH.—SEMI-ANNUAL MEETING OF THE BURMAH RUBY MINE CO.

LONDON, July 10, 1889.

I suppose it is not in the nature of retail jewelers, any more than it is in that of other traders, to express perfect satisfaction with the amount of business they do. I am both disappointed and puzzled. For the past few days I have purposely made numerous inquiries as to the amount of business done. I expected better reports. I know we have had hundreds and thousands of strangers passing through London, either to or from Paris, and I hoped, and it seemed our shopkeepers expected, they would have patronized our trades more extensively. There is plenty of time for the season to be a good one yet; still, in the uncertainty to which the jewelry, perhaps more than any other trade, is liable, we have not done so well as has been anticipated. Manufacturers have been fairly busy, but not so much in the execution of orders actually booked as in anticipation of the future. I think they are wise in making some preparation, because there are plenty of indications that goods will be wanted before long. Experience has taught us not only that much foreign money will be spent with us, but that we may rely upon the jewelry and fancy trades getting a fair share of it. The shipping trade has been quite as busy as it usually is at this season, but it has been noticed that orders have mostly been for articles of a less expensive kind. There have been some good consignments to Australia and South Africa, but very few best class lines included in them.

Our regular home trade is always interfered with in these months, our middle class population taking their holidays, which are usually spent at the seaside, or, at any rate, out of London, and our upper class quitting London as soon as "the season" is over.

PRIZES AND PRESENTS IN VOGUE.

I find that in the trade which has been done prices have been very low. Competition, natural and artificial, is very keen—by artificial competition I mean the introduction suddenly of large bankrupt stocks, which are forced into the market at any price, and are then retailed often at less than cost of production.

The presentation season has been one for which manufacturing jewelers should be thankful. Athletic, angling, rowing and cricket clubs have all been giving somebody something. Wedding presents have also been in greater demand in our trades than usual in summer. A good precedent has been set by Mrs. Wm. E. Gladstone, who presented the daughter of Sir Walter Foster, on the occasion of her marriage at Cambridge, with a coral brooch. Coral—the pale pink type—has been a favorite, but there is no doubt Mrs. Gladstone's example will be followed in many cases. I think it was a most suitable selection. Pale coral will be the fashion.

CASKETS AND PRESENTATION PIECES.

A very handsome casket has been designed by Mr. Whitmarsh, jeweler, of Trowbridge, and manufactured by B. H. Joseph & Co., of London and Birmingham. It is in the Renaissance style; silver gilt, very richly embossed and engraved, and is supported by six carved feet. The casket was presented to the Mayor of Trowbridge on the occasion of the opening of the Town Hall there. It was

intended as a mark of the respect in which the Mayor, W. R. Browne, Esq., is held by his fellow-townsmen, and the design of the casket is in accordance with this object. The front contains a view of the Trowbridge Town Hall—*repoussé* work, very beautifully executed in oxidized silver. On the back of the casket is seen the old castle of Trowbridge in *repoussé* work, also oxidized silver, while at one end are the royal arms and at the other end Mr. Browne's armorial bearings, enameled heraldic colors. The top of the casket is the royal crown on a cushion resting on a dome supported by pillars. The whole conception is highly creditable to the designer, while the work has been executed with a delicacy of finish of which Joseph & Co. may be proud. I should mention as explaining the reason for the introduction of the royal emblems, that the presentation was made to Mr. Browne by H. R. H. the Duchess of Albany on behalf of the townspeople. I believe Her Royal Highness has some connection with the town.

There have been several other noticeable presentations to which the jewelers' or silversmiths' art has contributed the gift, but I can only mention a silver shield 15 or 16 inches high, resting on a stand of ebony and supported by three rifles. This is the "Challenge Shield of the Royal Durban Rifles," and has been manufactured by John Thomason, Spencer street, Birmingham, and is executed with the best possible taste. The work is not only a splendid specimen of artistic skill, but is also singularly appropriate in its design. The decoration is quite characteristic of the artist itself.

THE WEDDING RING.

The vexed question of the wedding ring is settled, the manufacturers unanimously agreeing not to sell wedding rings in future unless they are duly hall-marked. From wedding rings to a wedding is an easy and not unnatural transition. I may, therefore mention very briefly that at the wedding of the Duke of Portland with Miss Dallas-Yorke last month, the six principal bridesmaids each received a bangle watch with the face surrounded by diamonds, while the younger bridesmaids, of whom there were six also, were each presented by the duke with a small ruby and diamond heart surmounted by a ducal coronet.

SALE OF RELICS OF NAPOLEON III.

On the 12th of last month a sale took place that is likely to become historical. It was a sale by auction of a quantity of porcelain faience and bric-à-brac belonging to Camden House, Chiselmurst, so well known as intimately associated with the fortunes of Napoleon III. and his family. The sale was by order of the executors of the late Nathaniel Strode. This gentleman lent his house, fully furnished, to the exiled emperor.

Considering the unusual interest attaching to the articles, the prices obtained for them were not high. A Louis XV. cartel clock, by Filon, in ormolu case of scroll design, with a dragon, flowers and foliage, was sold for 136 guineas; a crown derby dinner service fetched 48 guineas; a pair of Campana-shaped dark blue and gold vases, with painted medallion, was sold for £40; another pair of vases, decorated with mythological figures, £37; an ormolu clock surmounted by a boy on a dolphin, £31; and several other articles in proportion.

OLD ENGLISH PLATE.

In connection with auction sales, I may remark that I have attended several with special reference to the old silver offered, and my experience is that it has throughout this year fetched (or *realized*, I should, perhaps, say to your readers, though the less elegant term "fetched" is very current here) very high prices. It has not always been that pieces of particular interest, or age, or workmanship have commanded high prices on account of either of these qualifications, but old plate generally has sold well for no other reason than that it *was* old plate. It is noticed that your countrymen have been great purchasers of this old plate, and have always shown special interest in any that bore the date letter of the earliest Georges—or, better

still, of Queen Anne. It is very remarkable how the value of Irish old silver has gone up, especially when we remember that a good deal of Irish silver was never marked at all. At an important sale of old Irish silver in London (at Christie's), some of it was hall-marked and some not.

THE SHAH IN STATE.

I have revelled in the sight of jewels of all kinds during the past month—in Paris and in London. If your papers have contained only one-tenth as much about the Shah and his diamonds as ours have, you will appreciate my forbearance in mentioning the subject very briefly. You will have read detailed descriptions far better than any I could possibly give you, so I need only say that the general effect produced by the more than brilliant scintillations as the sun shone on his decorations was truly the finest exhibition of precious stones I have ever seen. My experience in this line has been a limited one, comparatively. I have seen our own royal family in all their splendor on numerous State occasions, but their jewels have never impressed me so much with their brilliancy as those of the Shah did last week. As you read the description of them, you may be able to realize something of their effect. I have had several opportunities of seeing him and his decorations, indoors and out, and can say that none of the descriptions I have read have been exaggerations.

RUBIES AT THE ROYAL SOCIETY SOIREE.

I must mention (though it be briefly) the soirée of the Royal Society on the 19th of last month. I will so far restrain myself as to speak only of the display of oriental rubies, rough, cut and mounted, which was made for our delectation. It is only within the last few years that any one in England, except, perhaps, a few—very few—minerologists had seen a ruby in the rough state. All the rubies we have had came from India, cut by the native lapidaries. This crude cutting left the stone in a very imperfect state, the object of the native workers having always been to get weight and color, rather than brilliancy. This collection of rubies, exhibited by Mr. Streater, was from the Burmah mines, and was the subject of much interest, especially to the ladies. There was a very fine specimen of a ruby in its matrix, in which the matrix was composed of calc-spar, associated with oxide of iron. Indications were pointed out to me, from which it is inferred that the stone had travelled a long distance, and had been much water-worn. There was a large cut stone shown of about twenty carats, Indian cut and of magnificent color. It was, however, so full of flaws that it would be dangerous to attempt to recut it. The stone, as it is, is valued at £2,000. Were it not so defective, it would be valued at £10,000.

MEETING OF THE BURMAH RUBY MINE CO.

On the 24th ult. the statutory meeting of the shareholders of the Burmah Ruby Mine Co. was held in London. We all remember the sensation attendant upon the issue of the shares last February; how the police had difficulty in keeping back the crowds who thronged Messrs. Rothschilds' doors in St. Smithen's Lane; how the chief of the firm had to make his way out through a back window; how the list was closed as soon as it was opened, and how the 200,000 shares offered to the public were subscribed to fourteen times over. All this is matter of history.

But during the past six months we have heard some little about this venture, and so there was very considerable interest attaching to that statutory meeting, and every one knew it. The chairman, Sir Lepel Griffin, succeeded in investing with some little romantic interest the usually very prosaic speech which the chairman has to make at the statutory meeting of a mining company. He did this by drawing a vivid picture of the difficulties always incidental to the search for the most precious jewels in such a country as Burmah, and by giving a graphic account of the splendid results which the history of ruby mining for ages past in that country affords. Of course the inference he wanted his audience to draw was that the results which had been achieved in the past might reasonably be hoped for in the

future. He was not quite so fluent or so happy when he came to confess that the government concession to the company extended only to seven years, and he was obliged to admit that the capital of the company invested must be replaced and the profits upon it must be made in those seven years. He does not consider this estimate too sanguine, because, as to the past, he says that of the most valuable jewels discovered, some of them, worth, very probably, £10,000 or more each, have been broken up by native miners rather than they should be confiscated to the king or treasure-trove, the former condition of the royal leases having stipulated that stones of a certain value should be given up without compensation.

He explained that the mines lie in an inaccessible mountainous district sixty-four miles from any river communication with Mandalay; that the country is subject to a fever fatal to white men, and is infested by a fierce band of robbers, the dacoits. He explained, as best he could, that before any results can be expected, a costly road must be constructed and the newest types of English or American machinery must be dragged up, under heavy escort, to the mines. Under these circumstances, more than one year out of the seven years concession must pass before any really productive work can be commenced. The chairman believes that in spite of the many difficulties to be faced the prospects are good. Major Aubrey Patten, who has resided for some time in the districts, says the royalty to be paid the British Government is not greater than the rent native miners have paid to the King of Burmah, while the company are not likely to be so heavily handicapped by the loss of the best stones.

It is evident that the real value of the mines will be in the larger stones. The discovery of a few only of these equal to some of the largest yet found will recoup the company. Personally I don't consider that the company made a good arrangement with the government. But shareholders knew the nature of it when they rushed so frantically into the speculation. One point is clear to all outside the scheme who have any commercial experience—that if the mines should prove anything like as valuable as is anticipated, at the end of the term of concession a much higher rate will be demanded for its renewal.

VIGILANT.

A Method of Demagnetizing Watches.

WATCHES can be demagnetized by taking a bar of Norway iron 1 inch in diameter and 20 inches long, costing 25 to 40 cts., and winding it with copper wire $\frac{3}{4}$ of an inch in diameter, insulated and paraffine-coated, costing 28 cts. a pound and requiring about $1\frac{1}{4}$ pounds, the wire being in two pieces of equal length and wound in opposite directions, crossing each other on opposite sides of the iron at every turn, and thus closely covering the iron nearly its whole length, and having a wire clamp driven on at each end of the iron to keep the wire in place, and having a spare foot or two of the wire left free for connections at each end. The whole then being shellac-coated to secure the wire well, and a small channel cut through the insulation for the whole length of the iron, which the small part of a sharp rat tail file will do best, so that when both the wires, at one end of the iron are attached to the battery or dynamo, the wire from the opposite pole of the battery being brought in contact with the coils in the channel where the insulation is removed and rapidly passed along the whole length of the iron, touching thus each of the coils in succession alternately, the electric current is reversed at each wire it touches, thereby reversing the poles of this soft iron magnet as often as the wire, which is moved along and touches each successive coil. The first move is the whole length of wound magnet, the next is a coil or two less and each repetition of the movement is less and less till it comes to making contact with only the last two turns of the wire on the iron, when the effect is complete. The operation is the work of a few minutes, and requires an outlay for battery and all, if four gravity cells (quart cells) are used, of less than five dollars.

The watch is to be placed against the end of the iron



[FROM OUR SPECIAL CORRESPONDENT.]

PHILADELPHIA, July 20, 1889.

Obedient to the god of the summer solstice, Philadelphia jewelers are taking stock and vacations. The prospects for the fall trade are good and all are resting on their oars till the signal to start is given.

B. J. Cooke's Sons have been taking stock and find that they are considerably ahead of last year on the business of the past six months, but they are not satisfied and are willing to be worked harder if necessary. W. L. Cooke the oldest member of the firm, has just purchased the very handsome brown stone front residence, No. 1536 S. Broad st., which he expects to occupy about Sept. 1st. Just now he is taking a vacation, and is visiting Mr. Fenton, of the New Haven Clock Co., near Boston. B. J. Cooke has also invested some of his profits in real estate. C. J. Cooke has rented a furnished cottage at Ambler where he enjoys the evenings and Sundays with his family.

James W. Queen & Co. report a large increase in special order work for spectacles and eye-glasses upon prescription, to such an extent that they have doubled their power, putting in a magnificent new engine, and have throughout improved their plant. They fully recognize the necessity of furnishing glasses in time for them to be worn by the patient before the effects of the mydriac have passed off, as the patients become accustomed to their glasses much easier under such circumstances than when there is much delay.

It is announced that Bowman & Musser, the jobbers of Lancaster, Pa., will soon open a branch establishment here under the supervision of Geo. Greubel.

Charles L. Hirst, diamond dealer, at 631 Chestnut street, had the misfortune to break his leg while alighting from a moving train in Newark recently. He was removed to his home and is doing well.

The Nationals, a picked nine from among the employees of the National Watch Case Co., 715-717 Arch street, defeated a nine selected from among the jobbing jewelers, on the 6th inst., by a score of 18 to 9. The Nationals will form a permanent organization.

T. M. Knight, the precious stone dealer, is traveling in Europe.

D. F. Conover and family are summering at Long Branch.

William Zineman, of M. Zineman & Bro., the South Ninth street optical firm, sailed for Europe last Monday to combine business and pleasure. M. Zineman's address out of business hours is "Diamanta" Cottage, Atlantic City, N. J.

McCall & Newman narrowly escaped a serious fire recently.

H. Muhr's Sons are extending their boundaries. Simon Muhr, head of the firm, has purchased several houses and grounds on the south side of Race street, 140 feet west of Broad. The property, which comprises four dwellings on Race street and six fronting on a small court in the rear, is 40x100 feet, and adjoins their present factory building on North Broad street. The dwellings will be torn down, and a building occupying the entire lot will be put up conforming in style with the factory. The increasing business of the firm requires an enlargement of its manufacturing facilities. The new structure will add about 28,000 square feet of working room to the 70,000 or more square feet now utilized in the factory. Work will be begun as soon as possible.

Within the vaults of Bailey, Banks & Biddle are the jewels of wealthy people to the value of nearly seven millions of dollars. They are the wedding presents of Miss Drexel, who married Bob Morrell; the diamonds of Mrs. Harrison, the wife of the Russian railroad prince; the family jewels of the Scott, Biddle and Lippincott families, and the other day they received an order from the

Duchess of Marlborough to make and send her a coronet of diamonds to be of unusually fine stones and "to be set as no other stones are set." At this time, it is said, they have an agent in the diamond fields of Africa, who has *carte blanche* to purchase the most beautiful and costly stones for a bride of the coming fall.

The National Optical Co., corner of 11th and Mifflin streets, are now ready to fill orders for their patent flexible eye-glass described in my last letter, and anticipate a very large demand for this latest and best improvement in eye-glasses. Their patent compensating spectacles are growing in popularity.

I. Bedichimer, maker of masonic marks and badges, 618 Chestnut street, is too busy filling orders and getting out his new fall stock to take a needed vacation.



[FROM OUR SPECIAL CORRESPONDENT.]

CHICAGO, July 20, 1889.

There is nothing intense or exciting hereabouts except the heat; it is too hot for many observations. Apparently nearly all the jewelers, both the proprietors and the employees, are resting up for the trade which is expected to begin before the middle of August, by visits to the country and the sea shore.

Hot as it is, a little extra stir was occasioned last week by the rumor that Oppenheimer Bros. & Veith, of New York, had bought all the No. 6 size, lever-set, Waltham watch movements in existence, together with a 14 karat gold case for each, and that having paid a very small sum for them they were in a position to demoralize the entire watch trade of the country. Some of the jewelers were quite alarmed at the ominous outlook, and talked wildly of the biggest deal ever made in watches in either Europe or America, which would, no doubt, amount to hundreds of thousands of dollars. It did not take much investigation to prove that Dame Rumor had very much over-reached the mark in this gossip, as has been her custom in most other cases. Mr. Avery, of the Elgin Watch Co., told your observer that he had heard the rumor, and showed him a telegram which he had received in response to a telegraphic inquiry which he had sent. It read: "There is no foundation whatever for the rumored purchase of Waltham movements and 14 karat cases. Oppenheimer has bought nothing from the Waltham folks since July 1, and has not 500 of their watches in stock." The whole foundation for the rumor would appear to lie in the fact, well known here for the past year, that the Waltham Watch Co. has been making ready for the introduction of the new No. 2 size movements, by selling out the No. 6 size in job lots. C. H. Knights & Co. bought all the No. 6 size movements which the Chicago office had in 10 karat cases some two months ago, and the purchase only amounted to about \$25,000. It is very certain that even were the Waltham Company to close out all their stock of these movements to one person the purchase would not cut any figure, for the reason that there are very few of them remaining in the hands of either that company or the trade.

This rumor calls to the memory of those who can think back 12 or 15 years, the "tempests in a tea pot" occasioned by the sale by the Elgin Watch Co. of their No. 10 ladies' watch movements, at the time of their discontinuing making them. Some few of the large jobbers gobbled all there were, and a great many of the smaller wholesalers criticized the Elgin Co. for not giving them a whack at them. They need not have been disturbed, for those Chicago jobbers who loaded up with them found that the sale of the new and more popular sizes which superseded No. 10 made it very hard work to sell the job lot at any profit.

The Elgin Watch Co. deny any thought of selling out their factory and business to the English syndicate, whom, so this very same Dame Rumor has repeatedly assured us, during the past few weeks, has purchased their plant. It is true that the syndicate has made an offer, and a very handsome offer, to the Elgin Co., but it is like the story of the man who came near buying a horse, the only trouble was that the other fellow would not sell.

The Englishman is not looking at watch factories alone, nor at breweries alone. He tells us that he is going to make gas for us at 25 cents per thousand feet, and he says it is only a question of time before he and his brothers will control all the best paying industries of this country. He says he has gotten tired of buying American railroads, and we cannot blame him much for arriving at this decision, but no well-balanced Chicagoan fears any ill result from the present movement of English capital towards this country.

Considerable complaint is heard in jewelry circles about packages consigned to various parts of the country being lost while in the hands of the express companies. The jewelers claim that no one of the companies will pay the value of the lost package until the end of a long lawsuit is reached. Of course, as is well known, a package lost by the freight companies remains unpaid for years any how, and forever if the railroad or freight company can tire out the jeweler; if he be persistent he will ultimately recover the value of his goods. It is such practices alone that made it possible for the swindler Post to establish his so-called freight claim bureau, in which he swindled so many wealthy Chicagoans out of all their surplus cash, and a well-known New York diamond merchant out of a small amount of gems.

As reported in THE CIRCULAR by your observer some months since, the United States Jewelers' Guild is now managed by W. H. Boynton, who will move the headquarters of the Guild to his brother's store, No. 282 State street, Chicago, as soon as he can get around to it.

The Northwestern Watch Club Co. has been incorporated during the month with a capital stock of \$150,000. Geo. Keene, Frank Reilly and H. S. Brenton are the incorporators.

The Chicago Watch and Case Co. lost about \$5,000 in the fire which occurred at their factory a fortnight since.

Chas. Bieling has sold out his stock of jewelry, closed up his shop and gone to Europe.

B. K. Chase is another jeweler who is reported to have gone away, but to lend a little variety to these announcements it may be stated that M. Spear has opened a new jewelry store on West Madison street.

Traveling bags and tourists' satchels have become quite a feature of jewelry establishments. Spaulding & Co., Chicago's largest retailers, show an elaborate collection of them with sterling silver mountings; the bags themselves are made of sealskin and lined with undressed kid.

L. B. Orton bought a stock of jewelry here in the early part of the month, and has opened a jewelry business in Ogden, Utah Territory.

H. H. Walton, the western manager of the Meriden Silver Plate Co., is the first to commence making active preparations for the fall trade. Two new center cases he is just putting in are 4½ feet high, 4 feet wide and 20 feet long, and will still further add to what is already one of the finest warerooms for the display of silver plate in this country.

Wm. Alister, of B. F. Norris, Alister & Co., writes from Europe that London and Paris provide a heap more fun than does the selling of jewelry in Chicago in hot weather. B. F. Norris, who usually spends his time in San Francisco mainly in collecting rentals from no one knows how many dozen houses there, is holding the reins here in Mr. McAlister's absence.

H. E. Howard, the Chicago manager of the Howard Watch and Clock Co., has taken unto himself a wife, and it may be added that he has taken both himself and his wife on a summering tour.

G. J. Corey, the western manager of the Pairpoint Mfg. Co., has returned from an eastern trip.

E. W. Prentiss, the manager of the Gorham Manufacturing Company's branch warerooms here, went East on the 15th, and will not return for three or four weeks. He will divide his time between looking up fun and picking up his fall stock at the Gorham Company's factory.

H. S. Peck, manager of the Waterbury Clock Co., has finished for the present his work as a Grand Jury man on the Cronin case, although he expects to be re-summoned to once more endeavor to help work out the great mystery, within a fortnight. In speaking about recent changes and improvements in the clock trade, he says that the iron mantel clock is fast disappearing, having been replaced by marble. A handsome solid marble clock is now sold quite as cheap as an iron imitation, but it must be borne in mind that the cost of these marble clocks has been lessened 30 or 40 per cent. within the past year, and a very handsome one is now sold to the jobbing trade at \$15.

F. G. Tnearle, Jr., manager and confidential man for C. H. Knights & Co., has gone East, to remain a month in the interest of his health and happiness and his house; he will spend a portion of the time in buying Knights & Co.'s fall stock.

By far the most important mercantile change of the month has been the sale by Wm. Smith & Co., the well-known gold chain manufacturers, of New York, to C. H. Knights & Co. of the Theodore Kearney Company's entire stock of watch materials, jewelers tools and watches and jewelry. The stock invoiced \$36,000, the fixtures are worth perhaps \$2,500, and there are \$5,000 in bills receivable. The entire establishment has passed into Knights & Co.'s hands, and it is their intention to close it all out, and turn their money within ninety days.

Doubtless many jewelers, both East and West, have heard some mention of Sheridan Road, which is now being made to extend 36 miles along Chicago's north lake shore, and passing Camp Sheridan, the military reservation, named in honor of "Little Phil." S. Hyman & Co., who are among the leading Chicago jewelers, have placed in their show windows two scenes, representations in miniature of Sheridan Road as it will appear when completed. The scenes are each supposed to represent one mile of roadway, and give a very clever indication of scenery along what will doubtless become the most noted drive in America. One is the road as it will appear in the summer, showing a tally-ho coach bowling along the road, while off on the lake are a number of vessels and the Goodrich line steamer *Chicago*. The companion piece is Sheridan road by moonlight, after the first snow. A steamer is seen in the distance plowing its way towards Chicago; a church along the roadside, with its snow-covered roof glistening in the moonlight, and a merry sleighing party adds its life to the realistic representation.

The Chicago jewelers, and, perhaps, the watchmakers in particular, are watching with much interest the result of the present agitation of the trust, pool and combination systems, now going on in many courts of as many States. Just at present all eyes are turned to New York, where the Supreme Court has just confirmed Judge Barrett's decision respecting the sugar trust in particular, but closely relating to trusts of all kinds, watches and jewelry not excepted. We understand here that this case is to be at once carried to the United States Supreme Court, in order to secure an immediate decision there, and if this is done interesting developments may be expected. It is difficult, however, to see how any action taken by any court can work much harm to such manufacturers as our Elgin Watch Co., for the reason that it is hard to hurt a man who can sell at his own price more than he can produce.

Among the out-of-town jewelers who have taken advantage of the cheap railroad fares offered to the Odd Fellows, Masonic and other conventions annually held in this summer resort, have been A. F. Hall, of Hall & Co., Janesville; Chas. Fey, of Fey Bros., Peoria; C. Jebb, of Jebb Bros., Jacksonville, Ill.; A. E. Harland, of Oakland, Iowa; E. Goldberg, August Bruder, Fort Wayne, Ind.; L. C. Hedskey, Big Rapids, Mich.; David Hess, Ottawa, Ill.; David Ayres, of T. R. J. Ayres & Sons, Keokuk, Iowa; W. W. Hunter, Bloomington, Ill.; and W. H. Sieberns, of Gridley, Ill.

PARIS GOSSIP.

[FROM OUR SPECIAL CORRESPONDENT.]

PARIS, July 15, 1889.

The Grand Prix has been this year still more animated than usual on account of the presence in Paris of a large number of foreigners come to view the Exposition. Favored with splendid weather very slightly damped by a little shower, people who went to the races and and those who waited, seated in the Champs Elysées, to witness the return of carriages, will preserve a pleasant recollection of that day. It is hardly necessary to mention the quantity of brooches, in diamonds, rubies, sapphires, or simply in cheap enamel, representing favorite runners, worn for the occasion. Those kinds of articles cannot alter very much from one year to the other. The horses may be reproduced more or less like life, but no striking originality can be introduced.

with one foot placed on a dull brass stool. She holds by the hair Holofernes' head resting on her slightly bent knee; her other hand rests on the hilt of a sword, etc. It seems a pity to see the fashion for cameos so utterly abandoned, and it is a wonder that special artists should still cherish a kind of work for which they cannot expect any retribution. Let us hope that they may succeed in attracting the attention of people endowed with taste to their praiseworthy efforts. If processes have been discovered which permit quick cameo cutting and which produce almost any pattern, yet in that branch of art, as in all the other ones, a thorough masterpiece, made by the independent hand of a true artist, ought to deserve a high and effectual admiration.

The immediate delivery of goods sold at the Exposition continues to provoke the anger of Parisian retailing jewelers. I am afraid that all their excitement will do very little towards preventing what they consider a serious evil. As long as exhibitors will be able to show that their glass cases contain the very same pieces which they are accused of having delivered to buyers, the Director of the Exposition can hardly interfere with them. Some patterns have been purchased and taken away ten times or more, and it matters very little after all, to find out whether the sample exhibited was, each time



DIAMOND BRANCH OF MEDLAR TREE FLOWERS.

The Salon, as brilliant as ever this season, has been attended with the habitual success. Large crowds of people visited it day after day, in May and June, in spite of the many attractions of the Exposition. Although the fashion for cameos seems to have entirely passed away, French artists in that line never fail to send new works to our annual exhibition of fine arts.

Georges Lemaire shows us, this year, forty profile portraits, being those of all the members of the Académie Française. The great variety of countenances is well rendered. It is evident from the difference in the expressions of the faces that if their possessors all belong to the same body, they cannot possibly be of one mind.

H. François exhibits a beautiful bust of Pallas, in sardonyx, of three colors; the face and neck in white, the helmet and breast armor in brown of two tinges.

Emile Gaulard has there a remarkable statuette in calcedony (pink and heliotrope) representing Judith, standing on a triangular pedestal

replaced by another one, or whether the manufacturer sent a copy of the chosen piece from his working place.

Another question, evidently more important, will perhaps be quietly solved. Fraud was to be prevented, yet pglauing on exhibitors avoided. In consequence, hall-marking officers have been appointed to visit the jewelry and silverware stands in all the sections in order to obtain from *Exposants* a rating of their goods. It is done in a very courteous way, the accuracy of statements being taken for granted. It is only at the close of the Exposition that all articles will be tested and stamped according to law, if they bear no legal marks. The same process must also be gone through for goods sold and delivered before the close. I am afraid that this last regulation will be often transgressed. It is, no doubt, necessary for the responsible authorities to show themselves lenient in their dealings with exhibitors, but they have to protect the public against possible frauds.

Some of the Parisian manufacturers who exhibit are still working with a view to increase their displays. It seems as though, now that they have the swing, they were unable to come to a stop. I hardly think that the new-coming articles will be examined by the jury of reward, but they may find favor among the public. Several of those pieces were commenced many months ago and were expected to be ready in time, but those which consist of elaborate chasing, combined with fine enamel work, cannot be hurried, and a few may have had to be re-made more than once. Besides, it often occurs that manufacturers give to visiting retailers (on approval) the striking piece prepared for the Exposition. In some cases, the customer *demand*s at once the article in question; consequently, another one must be made to fill its place at the Champs de Mars. This was the case with a pretty diamond branch of medlar tree flowers (an illustration of which we give here) which was meant to occupy a prominent place in one of the principal glass cases in the Jewelers' Court, and has been carried away to other climates.

French artists are known to be a very original class of people, who work only when they really feel so inclined, and who will never sit down to do the most trifling sketch unless they are in the right disposition for it. Designers for jewelry are no exceptions to that rule. One of the most refined in his style, H. Banneville, who exhibits some remarkable works at the Champs de Mars, in the Arts Libéraux, is a striking illustration of it. The Palais Royal houses know it well, and if their favorite designer chooses to spend a few days in the country (face to face with nature), they never attempt to oppose it, as they feel confident that, from his rambling among the fields, he will bring back to Rue Molière—to his little room under the roof—a freshness of inspiration which must give life to the expected designs.

Parisian retailers are getting quite busy, but some of them never will give up complaining; they say "that their chance customers are always in too great a hurry. This is, however, generally the case with foreigners and provincial people. They go to and enjoy themselves at the Exposition, or somewhere in the vicinity, and, just before starting for their native lands or remote towns, we receive a rapid visit. They *must* have this, or that, or something else, *at once*. Impossible for them to wait another day; they ought to have been off long ago, etc. Then the peaceful retailer has to run about in a feverish state and get the coveted piece." How can it be otherwise? And why should those welcome visitors purchase anything before they have a look around? Besides, you ought to consider yourselves happy, retailing jewelers, my friends, to do a little business of a palatable kind, even if you have to exert your wits and body more than usual for it.

Silver flat ware, such as spoons and forks, is gradually admitting pierced work, and, although that field of decoration might appear at first rather limited, it gives a very large scope to fancy. Some lovely things in that line are made in imitation of old locksmith's art, either in Gothic or Renaissance style. I shall give you, later on a description of some remarkable pieces.

JASEUR.

TEMPORARY REPAIR.—Sometimes when teeth are broken, small holes are drilled in the edge of the wheel and pins driven in to take the place of teeth. This plan is very good as a temporary remedy, and the writer has practiced this makeshift in repairing a clock, when it could not at the time be removed to the workshop; but, although proper under such circumstances, it is not to be commended as an example to follow when a clock has been taken to a workshop for thorough repairs.

OPTICS.—A German paper says that the latest invention of Edison is an apparatus with which one can see for hundreds of miles. Edison thinks that this new wonder will be rendered thoroughly practical long before 1892.

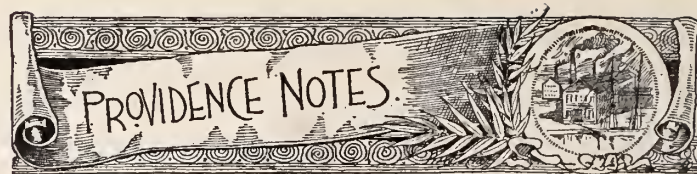

[FROM OUR SPECIAL CORRESPONDENT.]

PROVIDENCE, R. I., July 15, 1889.

Business, which started off about the middle of June with quite a rush and show of orders, has, during the past two weeks, quieted down very perceptibly, and for the first week of July it may be said that times were remarkably quiet. But since about the 10th, the improvement of trade has been very noticeable, although with some it is quiet at the present time and some complaints are to be heard. Duplicate orders do not seem to come along very fast as yet, but may do so later on. Some seem to think that the trade has been forced and that goods have not commenced to move yet. This may possibly be the reason for not receiving more duplicate orders. Collections are very dull throughout the trade. Failures have not been heard of during the past month or so or have been of little account to the manufacturer.

Alderman Edwin Lowe, one of the special committee of the City Council to arrange the celebration of the 4th of July, at the close of the military parade gave a complimentary dinner at his residence on High st. to Mayor Barker, fellow-members of the committee, his associates in the Board, and City Sergeant Rhodes. The dinner was elaborately served in courses and an hour was spent in a most sociable and enjoyable manner. The committee reviewed the military parade and trades procession at the corner of Sutton st. and Broadway, and were the recipients of early morning serenades by the Continental Band.

Rudolph Epstein, the able representative of Veit & Co., of Gablonz, Bohemia, sailed on July 17th per the North German Steamship, *Saale* for a four months' sojourn. Mr. Epstein recently met with a sad loss in the death of his father, and has the sympathy of THE CIRCULAR in his sad affliction.

Ostby & Barton, ring manufacturers, of No. 80 Clifford street, have a larger and more select line of solid gold and engraved band rings than ever, and with prices that will compare with any in the market.

Kent & Stanley, of No. 7 Eddy street, have on exhibition at the Paris Exposition a collection of different styles and designs of their celebrated seamless gold watch chains which are being greatly admired for their workmanship and fine finish.

The manufacturers here have received notice that the business heretofore conducted by J. R. White, of Rochester, hereafter will be known as the J. R. White Jewelry Co., incorporated capital stock, \$250,000.00, with J. R. White, President, Frank A. Smythe, Secretary, and James L. Wall, Treasurer.

Foster & Bailey are doing a heavier business with their celebrated "Mount Hope" and "Omega" sleeve-buttons than ever before. The public seem to appreciate a good article when they find it, and give it the support which it justly merits.

Wm. R. Dutemple has been re-elected President of the Odd Fellows' Beneficial Association.

The Jewelers' Sick Benefit Association held their regular annual excursion on the 30th ult., instead of the 16th, as at first proposed.

Levi L. Burdon has been granted a patent on an improved pattern of a finger ring.

The power in the Owen Building has again started up, having closed down the latter part of June to give the following named concerns a chance to make necessary alterations: G. & S. Owen & Co., D. Wilcox & Co., J. W. Richardson & Co., Potter & Buffinton, Wightman & Hough, and A. T. Wall & Co

The firm of Wild & Banister has dissolved partnership, R. B. Banister having retired.

W. S. Greene & Co. have commenced business at No. 25 Calender street.

Edwin Lowe, H. S. Dorchester, and Silas H. Manchester were on the joint committee of the 4th of July celebration.

M. L. Reed & Co. are now represented through the West by James Underwood, who is making the regular trip.

John R. McAdams & Co. have started in the manufacturing business at No. 52 Aborn street.

R. A. Greene has removed from No. 180 Friendship street to No. 129 Eddy street.

W. A. Ballou & Co. are located in their new quarters in the new Champlain Building at No. 74 Chestnut street, where they have greatly enlarged facilities to meet the requirements of their fast extending business.

T. E. Carpenter is represented in New York by F. W. Collom, who has charge of the office.

M. Fitzgerald has been elected a director of the Mercantile Trust Co. of this city.

The case of Albert Lorsch & Co. vs. Clarke & Turner was brought up in the Court of Common Pleas on Monday before Judge Tillinghast, and a *nil dicit* judgment was awarded to Lorsch & Co. for \$348.45, amount of debt and costs.

A. B. Day & Co., masonic badge and locket makers, have a full line of new charms on the market. This house is represented by Ira Johnson formerly with C. F. Irons; also Geo. Hopkins, late with C. A. Russell & Co.

The regular quarterly meeting of the Manufacturing Jewelers' Board of Trade, was held at the rooms of the association on Saturday the 29th ult., at 1.30 P. M., when the regular routine business was transacted.

Abram Colman, lately connected with the Gorham Mfg. Co., died on Sunday evening.

J. H. Fanning & Co. will now be represented on the road by B. F. Crandall, late with H. H. Curtis & Co.

I. Gutman was in the city during the past week stopping at the "Narragansett." He looked over the "lines" of some of our largest manufacturers and made some large purchases.

F. T. Pearce & Co. show a larger line than ever for the fall trade in gold pens, holders, etc. Their new fountain and stylographic pens are among the best in the market. They have many new and beautiful designs in pencils and holders and are meeting with large sales.

The reputation of J. Briggs & Sons stands without question in regard to the high standard goods which they manufacture, all grades of plate are made by this house, and are always found to be as represented in quality.

Towne & Ingraham are the successors to E. B. Ingraham & Co., at No. 29 Point st., and manufacture a general line of gold and plate chain, buttons, novelties, etc.

C. A. Russell & Co. have met with very flattering success so far the present season with their extensive line of emblems, charms, etc. which this wide-awake house manufacture.

On Monday last, at a meeting of the stockholders of the Citizen's Saving Bank, John Austin was elected President, and Edwin Lowe and Arthur E. Austin, Directors.

The contract for making the official badges to be worn by the Knight Templars at their triennial conclave in Washington, D. C., in October, has been awarded to Chas. F. Irons.

Davis & Emerson are meeting with great success with their new "Monarch Belle Post Solderless Collar Button," and have lately placed many new and unique designs of it on the market which seem to be fully appreciated by the trade all over the country.

Hancock, Becker & Co.'s new patent setting has taken the trade by storm to judge by the heavy orders that are being received by

them. Their line has been greatly extended to meet the call of the fall trade and it is meeting with well earned success.

Hamilton & Hamilton, Jr., are running to a good business in their ever popular line of gold and plated chain, and seldom complain for want of orders.

Charles Downs has met with the most flattering success so far with his new line of cane heads, etc., which he has placed on the market the first time for the fall season,

FAIRFAX.



[FROM OUR SPECIAL CORRESPONDENT.]

BOSTON, July 18, 1889.

This is the dead center of trade progress. It wouldn't take much to bring things to a standstill. Society has left the city, and the jewelry demands of what few weddings and receptions take place are trivial both in number and character. Many of our dealers have themselves taken advantage of the midsummer stagnation to go abroad in search of fall novelties, while those left behind are content to idle away this annual season of commercial fallowness.

The curious history of a diamond necklace is brought to light by the suit of Alfred H. Smith & Co. against the Adams Express Company. The jewel, which was valued at \$1,600, was shipped in 1879 to A. B. Griswold & Co., of New Orleans, but was lost in transit and was not recovered until an expense of \$260 had been incurred. Even then it was seriously damaged, and the New Orleans firm refused to accept it. The express company demanded reimbursement for the expense of finding the necklace before returning it to Smith & Co. This the latter refused to do, as the loss was due to the carrier's carelessness. They also refused to accept the ordinary indemnity of \$50 for accidents to unvalued packages. And so the matter rests pending the trial.

Jeweler William Rogers, of Watertown, died in the latter part of June from a stroke of paralysis. He was 69 years old and leaves a widow and children.

Jeweler Charles Salie has removed from 1,175 Washington street to 6 Cambridge street.

The meeting of the creditors of Charles E. Davis will be held here to-morrow, July 19.

The building at 46 School street, occupied by A. A. Robert & Foster, has been sold. The firm's lease expires soon and a removal of their watch case manufactory is almost certain.

The creditors of Austin Bros. meet July 26.

J. H. Klein & Co. have furnished a new store at 324 Tremont street.

Louis J. Wyman will try to reach a settlement with his creditors on July 26.

E. J. Boyle, of Boyle Bros., sailed recently for Europe. He received a farewell presentation of an elaborately engraved gold watch and chain. The former was a chronograph movement.

A merchant's convention will be held here in the fall, beginning Monday, September 9.

Jeweler David C. Percival is summering with his family at Marblehead Neck.

Laurence & Co. is the name of a newly established firm at 493 Washington street. W. F. Lawrence, F. H. Cox and W. H. Hooper are the partners. They will do a wholesale business.

Miss Alma M. Addison, daughter of Chas. I. W. Addison, of

Addison Bros., Chelsea, was married recently to Wm. L. Haynes at the Addison residence.

The installment jewelers of this city have been forced to organize for mutual protection against fraud. They have formed the "Credit Jewelers' Association," with A. D. Cairns, President; W. B. Foster, Secretary; Wm. M. Thompson, Treasurer.

Chas. Harwood, of Harwood Bros., sailed for Europe early last month with his daughter, on the *Scythia*.

The re-organization of the Craighead & Kintz Manufacturing Company, with a capital of \$250,000, disposes of many unpleasant rumors that have been circulating of late in regard to the old company's financial embarrassment. The concern manufactures chandeliers and fancy metal goods. It would seem from all accounts, the Pacific guano failures involved Glidder & Curtis to some extent. Their association of clothier G. W. Simmons, lawyer J. O. Teele and banker J. M. Graham with the business will wipe out many perplexities, and leave the new corporation with \$50,000 in the treasury. Mr. Simmons is President and John H. Fiint Treasurer of the concern.

Wm. Bond & Son have taken their chronometer business to 134 State street, and their watch department to 94 Boylston street.

A bogus customer robbed J. J. Keating of a non-magnetic watch a few days ago.

A sensational story comes from Bangor, Me., concerning Jeweler Chas. S. Gilman, whose store was recently robbed and burned. He left his father's house, where he and his wife were stopping for the night. A little past 6 o'clock the horse and carriage were found a mile beyond, with a note saying that Mr. Gilman's body could be found in Puchaw's pond, several miles distant. There one of the boats was found broken from its moorings and adrift. Gilman is said to have been the first to reach his own store on the night of the fire, and to have told some of his friends that he then found \$200 in the safe, which was then open, but in his excitement he did not take it. Detectives have gone to Corinth from Boston, but no new developments are yet reported.

LEON.



[FROM OUR SPECIAL CORRESPONDENT.]

ATLANTA, July 10, 1889.

This is the midsummer season in the south and trade in the jewelry line is about as it usually is this time of the year. Very little buying is going on and the retail merchants are taking advantage of this lull in business, and are spending a while at the sea shore or in the mountains.

The crop outlook was never better. Cotton, which is our standby, looks uncommonly well, and the indications are that over 7,000,000 bales will be grown this season. The fruit crop is the largest for years, which means considerable money for Georgia, as she can boast of the largest fruit farm in the world, consisting of several hundred acres, owned and operated by Mr. William Parnell, brother of Mr. Parnell, the great champion of the Irish cause. Altogether the outlook is bright for the early fall trade.

It occurs to me that the jewelry trade is being prostituted, probably more than any other branch of commerce. The counterfeiters are abroad in the land, and the "cheap John" business is taking the country. The merchants in the clothing, grocery, and in fact every line, are offering a "Solid Gold" watch free to everyone who will buy a certain amount of goods. The newspapers are clubbing a watch with their weekly editions, and so on it goes.

If all the watches are gold that are claimed to be it is a very easy matter to get a gold watch. The greed for money is so great that

newspaper men are not satisfied with the legitimate profits of their own business, but reach over and take in whatever they can, and at any price, from the jewelry trade. This may be legal, but it is bad ethics.

T. J. K.

How Often Should a Chronometer be Cleaned.



R. C. BEUCHEL, of Odessa, says complaints are frequently heard that chronometers, after having been cleaned, do no longer go as well as before, and it must be acknowledged that this is often indeed true. But when we inquire into the reason of this phenomenon we will almost invariably find that the owner of the chronometer let his timepiece go too long before having it cleaned, or else that he went to a botch watchmaker.

It is true that chronometers will frequently preserve a good rate for five, six or seven years, but when after the lapse of this time the timepiece is handed to a watchmaker to be cleaned, it will result with never-failing regularity that all the pivots, and especially those of the balance, are so badly worn by having gone too long without cleaning, aggravated by the ruined oil, that they will shake in the cleaned pivot holes. This might not make so much difference for the pivots of the train wheels, but every watchmaker knows that the rate is essentially influenced by worn balance pivots, and that in this alone may be found the reason why a chronometer will march much worse after cleaning than before.

The explanation for this is very simple. The chronometer is in such a way suspended in its zymbals, that in the pitching of a ship it remains in a well nigh horizontal position, and this suspension is contrived so that its motions take place with some friction. This friction, however, produces the effect by which one might say the chronometer constantly assumes a slightly altered position. This is undoubtedly the cause of the bad rate, because the effect of it is that the worn balance pivots in their holes assume a constantly changing position, and therewith the balance to the scape wheel and other parts of the escapement.

The scape wheel, as well as all the other wheels, are, in consequence of their little weight and the much greater power by which they are moved, in the condition that their pivots will always assume that place within their holes, whither they are pressed. This, however, is not the case with the balance, because it is much too heavy, so that by the least change in the horizontal position, it occupies a new relative position to the escapement. These irregularities occasion, first, an inequality in the difference of the arc of vibration, and next, a greater friction in the holes of the balance pivots, because these latter have assumed the well-known shape of the hole. It is entirely inadmissible to re-polish the pivots to restore to them the straight form, and simply makes matters worse; the readiest way to correct the evil is to put in a new balance staff; the chronometer loses thereby nothing of its value, and will afterward march just as well after having been cleaned than it did before it, and when in the prime of its excellence. Such a proportionally costly repair, however, may be averted by the possessor of the chronometer if he does not defer too long the cleaning. This procrastination of having the timepiece cleaned might be called downright want of care; the possessor of such a delicate instrument should know that even the best oil used for this purpose will become thick and acid after two years, and if the chronometer marches well after two years this should be considered as the very latest date, and cleaning can under no circumstances be deferred longer than this.

I repeat that in chronometers which have marched five or six years, the balance staff should unconditionally be renewed, and the conscientious repairer, when some one brings him a chronometer in this condition, should at once inform the possessor of this indispensable necessity.—*Deutsche Uhrmacher Zeitung*.



[FROM OUR SPECIAL CORRESPONDENT.]

KIMBERLEY, SOUTH AFRICA, JUNE 10, 1889.

Life here goes on much the same as elsewhere on this sublunary sphere. People come and go, are born and die; there is birthing and burying, marrying and marring the same as elsewhere. Only the pace is very, very fast. Recent statistics show that the death rate is higher than either Bombay or Glasgow, two of the most unhealthy cities in the world. The Europeans here pursue most every calling under the sun. If not diamond buyers they are "share and stock brokers;" if neither, they are "wholesale merchants" and "direct importers." Descending in the scale a little, we find them retail storekeepers, master builders, publicans, produce dealers, butchers, bakers, tailors, shoemakers, masons, miners, and members of a hundred other vocations. Hard work from the rising to the setting of the sun is the principal characteristic of their daily life. During the hours of darkness the place is a London, a New York or a Paris on a small scale, and every form of fast life is obtainable. Malays, Chinese and Indian coolies now form an important part of the population, while the native population is composed of members of every tribe on the southern portion of the African continent.

It is said that the De Beers, Dutoitspan and Bulfontein diamond mines have joined in the pool, for the purpose, presumably, of reforming existing evils; but it is my impression, and I hear on many sides remarks that strengthen it, that the consolidation has been effected more for the ruling of higher prices. When we recollect that the supply is approximately even, month after month, while the demand is constantly extending, the proportion of increase of the population wearing diamonds, greatly exceeding the ratio of increase of inhabitants. Then again, diamond mining is becoming more and more difficult and expensive as the years roll by. The mines are deep and the walls are all the more high by reason of the thousands of tons of reef, the results of past operations, which have been deposited upon the surface. Subsidences in the diamond fields, causing loss of life and money, have recently been of very frequent occurrence, scarcely a mine having not suffered to a more or less degree from falls of reef. It is said that underground operations, employing timbering mines composed of clay and shale, are the only remedy against these costly subsidences, but the cost of the undertaking of these methods is extremely heavy.

A large extension of payable diamondiferous ground was last week found in the Dutoitspan Mine. It is confidently believed by experts that if the additional ground is cleared for working, the number of claims in the mine will at least be doubled. In the Kimberley Mine, also, at the 750 feet level, a splendid deposit of "blue" has been discovered beneath the hard rock. Experience has proved that the deeper diamond miners go the richer the ground is found to be, and it is considered as probable that this new discovery will necessitate sinking to 2,000 feet.

The official figures show that during the month of May the diamonds exported from Kimberley to England weighed 290,018 karats, of the value of £385,632. During the month of April the diamonds exported weighed 281,673½ karats, valued at £377,825 16s. 6d. It will thus be seen that during the last few months the output has been regular, and that values on this side have not greatly fluctuated.

Models of diamond machinery and specimens of different kinds of ground are on view at the Paris Exhibition, to which center of

attraction many leading Kimberley residents have gone for instruction and recreation.

Travelling in the Transvaal a few weeks ago, I had an opportunity of meeting the old man O'Reilly, who can certainly claim to be the first individual who proved that diamonds existed in South Africa. But for this man's thick-skinned pertinacity the two hundred million pounds' worth of diamonds which have been unearthed since the discovery might still have been in the place where they had lain for ages. Yet this man has gained nothing by the discovery and is now working for his living; indeed, his constant complaint is that he was ruined by the diamond fields. Prior to the early stampedes to the fields he was a successful trader amongst the natives, but with the advent of the thousands of Europeans his occupation departed. O'Reilly stated to me that prior to 1869 no idea whatever existed in the minds of the colonists of South Africa that the country was rich in diamonds and gold. The country was then in a condition verging upon a general financial collapse and commercial bankruptcy.

The crime of I. D. B., as illicit diamond buying is termed, appears to be on the increase. At the last Special Court, which is held monthly for the trial of these cases, the Judge President intimated that it would be necessary to make sentences more stringent and arduous if this crime continued to increase. As it is, the punishment is very severe. Europeans are frequently sentenced to ten years' imprisonment on conviction of having bought a single diamond. To the general outsider this may seem unnecessarily severe, but in reality it is not so. The men who engage in the traffic are perfectly cognizant of the risks they run. Of course, the temptation is very great, for by a single transaction a man may gain a fortune. Many of the natives who steal the diamonds while working in the mines possess but dim ideas of their values. In a case before the court this week it was shown that a native boy had stolen a diamond and sold it for 35s, a bottle of brandy and an old coat. The purchaser, a European, transferred it to a third party for £250, and it was while the last "owner" was attempting to take passage to Europe, where, when cut, the stone would have realized at least £1,500, the illicit was caught. Of course, these robberies seriously interfere with the operations of the companies. It was at first thought that amalgamation and compounding would put an ending to much of this illicit dealing, but the crime appears to flourish still and even to increase. Detectives state that some of the most ingenious rascals from London and the large cities of Europe come out here for the especial purpose of engaging in the traffic. The majority of them elude detectives here for many years or return to their native places with their ill-gotten gains. Others are caught in the act and pay the heavy penalty.

I have recently had an opportunity of visiting Johannesburg, the new gold center in the Transvaal. There can be no question of the permanency of these fields, and it is not unlikely that in the future the output from that place, together with that of the numerous other fields in the region, will materially affect the gold production of the world. At present the output from Johannesburg alone averages 30,000 ounces of gold per month, but this is small to what will be produced when all the machinery is in activity. The fields furnish a melancholy testimony to the gullibility of the British public. Companies have been floated and hundreds of thousands of pounds of capital subscribed for the purchase of properties that are practically worthless. There has been swindling of the most deplorable nature. These fraudulent schemes, however, cannot much affect the good properties, which are numerous, and are being slowly, if somewhat clumsily, developed. It seems probable that the gold industry will remain an important one in the Transvaal for many years to come. There is clear evidence, also, for the belief that the countries north toward the Zambesi are marvellously rich in auriferous deposits, proving that the old adage respecting "Africa's golden sands" is not altogether deception.

Johannesburg is now a place of about 30,000 inhabitants, repre-

senting nearly every nationality. Life is rather fast there as in most young mining communities. The output of gold during the month of May totalled 32,000 ounces. It has been decided to send this output to the Paris Exhibition. Visitors will thus have an opportunity of seeing for themselves what *one* only of the Transvaal gold fields can produce.

In reference to this matter, however, I may be permitted to refer to an official report by United States Consul Hallis, at Capetown, on the gold fields of the Transvaal. He says *inter alia*: "No one in the United States can have an idea of the extent and richness of the gold bearing reefs or lodes, that have so recently been discovered in the Transvaal Republic. Even England, which is in such close commercial touch with South Africa, has just become awake to the fact that almost boundless wealth lies just across the borders of one of her colonies. The discovery of the rich deposit of diamonds in the Kimberley district was discredited and the reports sent from there were derided. The Kimberley mines, with their production of two hundred million dollars' worth of diamonds in the twenty years preceding 1885, and their annual output of twenty million dollars, now govern the diamond market of the world and influence the prices of the precious gem. Gold, fortunately, unlike all else preserves its value. One naturally associates gold mines with mountains. Of the latter there is a total absence. Only here and there rise the stone kopjes, mounds of loose detached feringinous rocks from 50 to 200 feet high, sometimes singly and again in ranges. The land lies as level as an Iowa prairie, rolling somewhat, and nothing bars the way from turning a team out of the road on either side, with the whole wide prairie before one. The mining territory already prospected covers an area of over 1,500 square miles. The richest mine I visited was growing richer as the depth increased, and was turning out 7 ounces of 22 karat gold to the ton. All the mines are producing from 1 ounce upward to the ton of ore, and the cost of working is on the average about four dollars. It would seem as if nature had determined to outdo herself when she stored up the mineral wealth of South Africa, the latest discovered, and, I confidently believe, the richest in the world. Silver now enters into competition with gold, side by side, territorially speaking. Taking Pretoria, 36 miles from Johannesburg, as a center, silver-bearing reefs have been discovered of a new character, with silver predominating, covering a radius of 30 miles, the extent of which is an unknown quantity. One mineralogist informed me he had assayed samples that gave 200 pounds of silver to the ton. In combination with the silver is found galena and copper to an extent that will more than pay the cost of working. It must be borne in mind that this is only the beginning of mineral discovery in this country. Thousands of square miles which in all probability will prove equally productive, are yet held by the ultra-conservative Boers, who will not permit a prospector to appear within their limits. An offer of two hundred thousand dollars has no more effect on their cupidity than the offer of so many cents."

I quote the above lengthy extract from the report of Mr. Hallis, because so great an amount of interest is being shown in the Transvaal by Americans, who are arriving in considerable though not large numbers. The fact is clear that this part of the world is marvellously rich in minerals of nearly all kinds.

The diamondiferous area is also much greater than many people have previously imagined. Within the last few weeks over thirty small diamonds have been found at a place about ten miles from Harrismith on the Natal border. Prospecting is actively proceeding. Near Delagoa Bay, too, on the east coast, some parcels of beautiful white gems have been found. As the place is in Portugese territory, however, the finders are very reticent about the exact locality for fear of losing their rights. They say the place is rich in promising diamondiferous soil. Near the mouth of the Zambesi a valuable pearl mine was found last month.

What Waltham is Doing for the Watchmakers of the World.

BY WENDEL F. FOSTER.



WITH THE increase of the watchmaking industry of this country, the invention and manufacture of watch-making tools has become a branch of the business; but it has of necessity materially increased during the past few years. As a pioneer, John Stark, Sr., must receive the palm, as his is the oldest establishment in this country, devoted entirely to the manufacture of watchmakers' lathes.

This establishment was founded by John Stark in 1862 and was continued by him until 1880, when his son, John Stark, Jr., was admitted to partnership with him, and the business was carried on prosperously until the death of the founder, when John Stark, Jr., bought the interests of the heirs of the estate, and the business is now conducted most successfully by him.

The factory, which is situated on Moody street, "South side," is a two story building 60x25 feet, with a wing 25x20 feet. During the past year Mr. Stark has added to his list of manufactures a great many improved tools, such as automatic grinders, milling and shipping machines, etc., to enable him to meet the increasing demand for his celebrated lathes. There is at present a force of 15 skilled men employed, and every detail is under the personal supervision of the able proprietor, Mr. Stark, who is a thoroughly practical man, and is also a worker himself, taking a hand at any intricate job when an occasion calls, and it is due to this mechanical skill that the "Stark lathes" have become so famous, for it is impossible to find a tool more perfect in design or finish, and the large number of them in use is a gratifying commendation of their merit. Of course, such a manufacturer as Mr. Stark is constantly besieged with orders for various machines and tools, and he has done considerable work for the American Watch Co. and other watch and clock companies.

John Stark, Sr., received an award at the Philadelphia Centennial of 1876, for a line of watch repairing tools; he received also in 1881, the highest award over all other watch lathe manufacturers, from the Massachusetts Mechanical Society of Boston.

The "Stark" mainspring winder is pronounced by all who have used it to be unequalled, and it is made in large quantities to meet the great demand for them.

The principal business, however, is the manufacture of American lathes, and every machine and device that ingenuity can suggest is used to produce them, and when it is understood that with these lathes every part of a watch from plate to jewel may be made, it is difficult to understand how a man having any pretensions to being a watchmaker can do business without one of these important tools. The "Stark" lathes are designated by the letters "C," "E" and "D." A machinist bench lathe is another product of this factory, and is especially adapted to use by clockmakers, modelmakers, electricians, and for numerous other kinds of small work requiring duplication or accuracy. The letter "C" has a bed of 9 inches and a swing of 4 inches; the letter "E" has a bed of 10 inches and a swing of 4¾ inches; the letter "D" has a bed of 12 inches and a swing of 5⅞ inches. The "E" is considered the popular size by watchmakers generally, and the "D" is preferred by chronometer makers and others desiring a heavy lathe. All of the lathes built are what are called hard lathes, that is, having the spindles and spindle bearings of hardened and ground steel, insuring a perfect fitting and light running lathe. All the latest and most improved attachments can be used on these lathes, such as universal heads, improved slide rest, jewelers and caliper tool, screw tail stock, pivoting or step head, rotary and staff polishers, arbor squaring fixture, wheel cutting and rounding-up attachment, traverse spindle grinders, etc., etc.

The Stark foot wheel is all that the inventor claims for it, it being of the swing-treadle style, which is the only kind of motion that

allows perfect control over the upper part of the body, so requisite for the finest work.

A visit to his factory will convince one that every man there is a workman, and thoroughly understands the work in hand. I will say to those who are not personally acquainted with Mr. Stark that he is a most entertaining man and well posted in all the mechanical arts, and able to give the great fraternity of watchmakers many points to their advantage

A. J. LOGAN.

The hairspring manufactory of A. J. Logan is located on Crescent street, "south side" in the commodious building owned by Bartlett & Dillingworth, which overlooks a portion of Charles River. Mr. Logan's office is on the second floor, with the factory in the rear, running the entire length of the building, with a separate room for the tempering. In this little factory a vast amount of business is carried on. Not only are hairsprings, and a large variety of small springs, such as bracelet, steam gauge and other kinds manufactured, but a number of watchmakers' tools, which are considered by leading material jobbers to be the best in the market. Many of these tools were invented by Mr. Logan, and are controlled by letters patent. Some of the gauges made by him require more than a passing notice, for there has long been a want among fine workmen for some moderate priced gauges of precision. One gauge is of the upright pattern and measures to the one-thousandth of a centimeter; and also a jaw and depth gauge measuring to one thousandth of a centimeter, and one of the same measuring to one-hundredth of a centimeter, and a promise of some shortly using the inch measurement. These gauges are sold for eighteen, fourteen, and eight dollars, as against the regular factory gauges, costing from forty-five to sixty dollars.

Of course Mr. Logan's principal business is introducing his justly celebrated hairsprings which are well known among the various watch and clock factories of the country. The making of these springs is a more intricate business than might be supposed by those unacquainted with its manufacture. Only the finest quality of steel is used and it is imported in large quantities from England. It comes specially drawn in round polished wire .008 diameter. The first manipulation is to draw it through sapphire-jeweled draw-plates to .004. The next process is to draw it through very finely constructed rolls, to flat it the required amount, then to be finally drawn through diamond draw-plates to the diameter the order may require. After its several drawings it is straightened, and is then ready for the "coilers." The coiling is done by winding the wire tightly into small metal discs or boxes, having a recess turned into one side sufficient to take the wire when tightly coiled, three or four slots, according to the spacing of the coils, are sawed in the edge of the disc, for the wires to run through; an arbor, also slotted to take the wires, is put through a hole in the center of the disc, and the wires being inserted into their respective slots are wound tightly and evenly until the recess is packed full, each little disc now containing three or four coils of wire soon to become springs. They are now "tied up" in stacks, with wire, and are ready for the tempering room; a number of packages of the discs are put into a large iron pot, closely packed with charcoal dust, which is placed in the furnace and brought to the proper degree of heat, and are plunged into water to harden; they are now "cut out" by girls, and dried off, when other girls called "finishers," pick them apart—a very delicate task, as they are as brittle as glass—and after cleaning, by a chemical process, they are blued; this first blue is removed, after which they are finely polished and blued for the last time, being now ready for the "inspector." The utmost care has to be used throughout the different processes, to ensure the perfection which these springs are noted for. No work is allowed to pass the "inspectors," unless perfect in every particular. It has only been in recent years that hairsprings, true in the round and flat, and evenly coiled, tempered and finished, have been produced in large quantities in this country: Some of the leading watch factories, preferring to

import Swiss or English springs and some companies that manufacture their own were put to large expense and much trouble to produce perfect springs. Mr. Logan was among the first to see the need of a spring specially adapted to American watches, and free from many of the defects of the imported ones, and immediately made arrangements to manufacture them on a large scale, and of the highest quality, many of the large watch and clock companies being among his customers. Thus by his ability and untiring energy he has proved himself a worthy representative of the skilled labor of Waltham.



The following list of patents is compiled from the records of the United States Patent Office, and specially reported to THE JEWELERS' CIRCULAR.

Issue of June 25, 1889.

- Design Patent No. 19,177**—MATCH BOX. HARRY P. FAIRCHILD, New York, N. Y. Application filed May 27, 1889. Serial No. 312,301. Term of patent $3\frac{1}{2}$ years.
- Design Patent No. 19,184**—SPOON, ETC. GEORGE P. TILTON, Newburyport, Mass., assignor to the Towle Manufacturing Company, same place. Application filed May 27, 1889. Serial No. 312,302. Term of patent 7 years.
- 405,783**—SCARF PIN. JOSEPH C. LEIBEL, Colorado Springs, Colo., assignor of one-half to D. Ashby, same place. Filed June 22, 1888. Serial No. 277,892. (Model.) A scarf pin having the portion of the pin opposite the ornamental head bent back out of the plane of but parallel to the portion below it, and connected therewith by the inclined part, whereby the rear face of the ornamental head will lie approximately flat upon the scarf.

Issue of July 2, 1889.

- Design Patent No. 19,189**—BADGE. JOSEPH K. DAVISON, Philadelphia, Pa. Application filed November 9, 1887. Serial No. 254,731. Term of patent 14 years.
- Design Patent No. 19,191**—BADGE. CHARLES F. IRONS, Providence, R. I. Application filed June 3, 1889. Serial No. 312,962. Term of patent $3\frac{1}{2}$ years.
- Design Patent No. 19,194**—BADGE. JOHN C. UNDERWOOD, Columbus, Ohio. Application filed May 31, 1889. Serial No. 312,807. Term of patent $3\frac{1}{2}$ years.
- 406,217**—OPERA GLASS HOLDER. GIDEON ISLEY, Jersey City, N. J., assignor to Edwin Terry, Brooklyn, and Leo Wormser, New York, N. Y. Filed February 5, 1889. Serial No. 298,713. (No model.) This device consists of a handle having an outer ornamental tube together with an intermediate continuous tube, and an inner tube which is slotted in combination with a sliding section having a stud.
- 406,356**—SPLIT CHUCK FOR WATCHMAKERS' LATHES. FREDERICK LAUTERMILCH, Kirkwood, Mo., assignor of one-half to Edward Wilmas, same place. Filed March 19, 1889. Serial No. 303,834. (No model.) In this split chuck for watchmakers' lathes the head is provided with a lateral opening into the tubular center of the chuck for the insertion of watch cylinder spindles and the step cone pulleys mounted thereon, and other objects to be trued by the lathe when presented to the grip of the chuck.
- 406,364**—ANTI-MAGNETIC WATCH. CHARLES T. MASON, Sumter, S. C., assignor, by direct and mesne assignments, to the American Waltham Watch Company, of Massachusetts. Filed June 26, 1888. Serial No. 278,256. (No model.) In this anti-magnetic watch a magnetic ring of soft iron surrounds the balance wheel; it is provided with an inwardly-projecting flange on its lower part.
- 406,383**—PROCESS FOR MAKING ALUMINUM ALLOYS. WILLIAM A. EALDWIN, Chicago, Ill. Filed August 21, 1888. Serial No. 283,364. (No specimens.) This process of aluminizing a metal consists in fusing such metal and pouring the same on an unfused compound of clay or substance bearing alumina, sodium chloride, and charcoal or other carbonaceous substances placed in a vessel or pouring ladle.

Issue of July 9, 1889.

- 406,513**—STEM WINDING AND SETTING WATCH. GEORGE F. JOHNSON, Aurora, Ill. Filed September 12, 1887. Serial No. 249,488. (No model.) In this improvement there is a lever actuated by the end thrust of the stem key, in combination with the lock lever and a swinging yoke, the said lock lever and yoke being so formed at the point of their contact as to cause the yoke with its attached wheels to be locked in engagement with the

dial wheels when the lock lever is restrained in its movement to a certain limit, but will permit the same to be automatically disengaged therefrom when the lock lever is allowed additional movement, as when the watch is removed from the case.

406,702—WATCH-WINDING MECHANISM. WHELOCK N. CLIFFORD, Waltham, Mass. Filed February 9, 1888. Serial No. 263,527. (No model.) This mechanism for winding a wound spring is composed of two loose turning gear wheels, an arbor or stud common to both of the gear wheels, two ratchet or clutch wheels, one for each of the gear wheels, two pawls or clutches to engage and to pass freely over the ratchet or clutch wheels, a gear wheel to directly mesh with one and to connect with the other of the loose gear wheels through an intermediate gear wheel and to rotate them in opposite directions, and a support for the driving gear wheel adapted to be adjusted to place the gear wheel in and out of the mesh.

406,816—WATCH CASE. EDWARD C. CHAPPATTE, Philadelphia, Pa. Filed March 2, 1889. Serial No. 301,730. (No model.) The combination of a combined watch center and bezel provided with a curved annular groove about the bezel portion and on the interior of the center, a movement holding ring provided with a curved annular rim adapted to fit into the groove, a removable back secured upon the combined center and bezel, and means to removably secure the movement ring in the combined center and bezel, and force the curved rim into the annular groove to form a dust-proof connection, consisting of a projecting ledge or flange about the surface of the combined bezel or ring and half head screws upon said movement ring.

Design Patent No. 19,203—HANDLE FOR SPOONS, FORKS, ETC. FREDERICK SCHMIDT, North Attleboro, Mass., assignor to F. M. Whitney & Co., same place. Application filed June 13, 1889. Serial No. 314,145. Term of patent $3\frac{1}{2}$ years.

Design Patent No. 19,205—SPOON, ETC. GEORGE P. TILTON, Newburyport, Mass., assignor to the Towle Manufacturing Company, same place. Application filed June 5, 1889. Serial No. 313,203. Term of patent 7 years.

Issue of July 16, 1889.

406,923—METHOD OF ORNAMENTS SURFACES WITH MOLTEN METAL. WILLIAM H. MARSHALL, Chelsea, Mass. Filed October 1, 1888. Serial No. 286,914. (No model.) This method of ornamenting surfaces with molten metal, consists of submerging the surface to be ornamented in a liquid, and pouring the molten metal in a stream into the liquid and onto the surface.

406,989—TIME SIGNAL. NICHOLAS H. BORGFELDT, Brooklyn, N. Y. Filed November 19, 1888. Serial No. 291,203. (No model.) This mechanism consists of a clock having a pointer and a means for automatically moving the same, a dial having independent sections and having its remaining portion divided into sections indicative of double the distance traveled by sound during the motion of the pointer, in combination with a movable index hand.

407,015—HANDLE FOR CANES, UMBRELLAS OR PARASOLS. AUGUST KESSLER, New York, N. Y. Filed April 4, 1889. Serial No. 306,026. (No model.) A head for canes, umbrellas or parasols, composed of a shell formed of a series of interlocking spiral strips, and a lining of lead or soft solder which holds the strips together.

407,040—BOX FOR REPEATING WATCHES. HENRI SANDOZ, Locle, Switzerland, assignor to Adolphe Schwob, New York, N. Y. Filed February 9, 1889. Serial No. 299,271. (No model.) This watch box is provided with an annular receptacle for holding a repeating watch, which receptacle has a notch for the watch pendant and a recess in which the pusher of the repeating watch can be moved, a lever pivoted on the box, and a pin projecting from the lever adjacent to the pusher of the repeating watch.

407,243—STEM WINDING AND SETTING WATCH. HENRY REMPE, Houtzdale, Pa. Filed November 21, 1888. Serial No. 291,420. (No model.) In a stem setting and winding watch, the combination of two plates, a pinion, a block, a yoke having a vertical arm, winding and setting mechanism carried by the yoke, a spring bearing on one end of the yoke, a lever having its lower end extended through an opening in one of the plates and engaging with the vertical arm, another spring, stronger than the aforementioned one, bearing on the lever, a stem and a sleeve on the lower end of the stem.

407,305—PROCESS OF DECORATING BASE METALS, GLASS, Etc., WITH PRECIOUS METALS. FRANZ ROESSLER, Perth Amboy, N. J. Filed October 22, 1888. Serial No. 288,833. (No specimens.) This process of decorating articles of base metal, glass, terra cotta and the like, consists in first applying varnish to the surface of such article, next drying the varnish, next applying a solution of the sulphuret of a precious metal and balsam of sulphur, and subsequently firing.

Design Patent No. 19,210 and 19,211—SPOON, FORK OR OTHER TABLE UTENSIL. EDWARD C. MOORE, Yonkers, assignor to Tiffany & Company, New York, N. Y. Applications filed May 24, 1889. Serial Nos. 312,005 and 312,006. Term of patents 14 years.

Design Patent No. 19,212—SPOON OR FORK HANDLE. WILLIAM ROGERS, Hartford, Conn. Application filed April 23, 1889. Serial No. 308,337. Term of patent 7 years.

Issue of July 22, 1889.

407,481—WATCH-MOVEMENT HOLDER. HEINRICH HEIDENREICH, New York, N. Y., assignor to Henry Zimmern, same place. Filed April 24, 1889. Serial No. 308,381. (No model.) In this device is combined a supporting-standard having guideways, a tooth segment guided in these ways a pinion meshing with the toothed circumference of the segment, and a movement-holding device that is pivoted at diametrically-opposite points to the segment and provided with a pawl-and-ratchet device for retaining the holding device at any suitable inclination to the segment.

407,566—BRACELET. WALTER B. BALLOU, North Attleboro, Mass. Filed Feb. 7, 1889. Serial No. 298,945. (No model.) A bracelet consisting of a number of independent disconnected units strung on an spirally-coiled elastic tube, having an endless chain in the tube constructed to limit the expansibility.

407,637—THIMBLE-EMBOSSING MACHINE. JOSEPH BROWNING, Philadelphia, Pa., assignor to John F. Simons, Frederick M. Simons, and Edwin S. Simons, all of same place. Filed May 14, 1889. Serial No. 310,720. (No model.) In this embossing-machine there is an embossing-wheel, its shafts and gear-wheel, with a thimble-carrying shaft, its pinion, an intermediate pinion, and intermediate wheel, the wheel being carried by a lever pivoted to the thimble-carrying shaft, but connected to the intermediate pinion, so that on the movement of the embossing-wheel toward or from the thimble the lever will be moved.

407,642—STEM WINDING AND SETTING WATCH. CONSTANT DIMCHERT, Montilier, near Morat, Freyburg, Switzerland. Filed April 11th, 1889. Serial No. 306,814. (No model.) In this watch is combined with the crown and the lever actuated by the crown and its stem, of a yoke actuated by the lever for bringing the setting and winding wheels into action and a detent for locking the lever both in the winding and in the setting position of the mechanism, the lever being provided with a locking-shoulder for holding the yoke in the setting position.

407,668—HOLDER FOR FINGER-RINGS. CHARLES A. KRON, New York, N. Y. Filed Mar. 1, 1889. Serial No. 301,657. (No model.) In this device is combined of fixed plate having a central opening traversed by a horn, and a surrounding slot, traversed by radial arms, with a superposed movable plate having a central slot, and prongs that engage the slot of plate.

407,719—THREAD-CUTTER FOR THIMBLES. ORRIN CADY, Cincinnati, Ohio, assignor of one-half to Willard B. Pritchard, Waterbury, Conn. Filed Apr. 2, 1889. Serial No. 305,658. (No model.) The inventor has here a thimble combining a thread-cutter consisting of an open elastic spring-metal band having one of its ends broadened, turned outwardly, and provided with a centrally-located cutting-edge, and with guards projecting above the cutting-edge at each side thereof.

407,723—ORNAMENTAL CHAIN. JOSEPH E. CROOK, Providence, R. I., assignor of one-half to A. T. Wall & Co., same place. Filed Dec. 26, 1888. Serial No. 294,633. (No model.) A chain made up of links each composed of an outer grooved ring and an inner ring partly or wholly embedded in the groove of the outer ring.

Re-issue.

11,014—WATCH-MOVEMENT. GEORGE HUNTER, Elgin, assignor to the Elgin National Watch Company, Chicago, Ill. Filed May 31, 1889. Serial No. 312,760 $\frac{1}{2}$. Original No. 347,272. dated Aug. 10, 1886.

CHEAP VARNISH.—To make a good, cheap varnish: Borax, 10 parts; powdered white shellac, 30 parts; water, 200 parts. Dissolve on the water bath, which will take several hours; when cold, filter. The addition of a few drops of glycerine will make the varnish much more flexible. For black, add nigrosin (soluble in water); for blue, methyl blue, alkaline blue or marine blue; for green, use malachite green or brilliant green; and for violet, use methyl violet. All these colors are coal tar colors.

Fashions in Jewelry

A Lady's Rambles Among the Jewelers and Dealers in Art Glass and Keramics.

THERE is a fad now among society women for collecting coffee and dessert spoons to figure at luncheons and "five o'clock" teas. In these collections duplicates are avoided and each spoon is a souvenir. The spoons especially prized represent the collection of a traveler who has visited many countries and many climes. In this case each spoon is etched or engraved with the name of the town and the date of the collector's visit there.

* * * * *

UNIQUE birthday collections are gained in a few years, in many families, by the custom now prevalent of presenting each child, on its birthday, with an odd piece or two of silver. Spoons large and small, and designed for a great variety of uses, are included in these gifts. It need hardly be added that this collection usually begins with the apostle spoons presented at the christening by the Godparents.

* * * * *

THE christening of infants born with silver spoons in their mouths is, by the way, an event that calls for an unlimited extravagance on the part of parents, and friends. Every well-regulated house in the fashionable world owns its own baptismal bowl, for one item. When of sterling silver these bowls are, as a rule, made to order, from designs drawn especially for the baby king or queen who first uses it.

* * * * *

"BABY silver," almost without exception, is decorated with designs especially adapted to little people. On many of the pieces are reproduced nursery rhymes and Mother Goose melodies in illustrations beautifully etched or engraved.

* * * * *

THE fashion is ever increasing for silver bowls of one kind or another. Bowls of medium size are wonderfully convenient articles and are employed for a variety of uses regardless of the original desire, as for punch, cracked ice, flowers, etc.

* * * * *

INFANTILE jewelry includes button studs, bib pins and finger rings, all of which are alike worn by boy and girl babies.

* * * * *

Little girls wear tiny bangles, and patronize finger rings to a larger extent than do their brothers.

* * * * *

THE turquoise and garnets have long been looked upon as the most desirable stones for setting in children's jewelry. Blue enamel also figures largely in infantile jewelry.

* * * * *

THE present craze for veritable antiques in jewelry has been

accentuated recently by the statement that the archbishop placed on Miss Elizabeth Drexel's finger, on the occasion of her marriage, the ring given by Martin Luther to solemnize his betrothal to Catharine Von Bora.

* * * * *

To be in the extreme fashion a chatelaine should be old, but silver ones of modern date, with their ten or twelve pendants, are nevertheless eagerly sought for by those who are without the heirlooms.

* * * * *

SILVER belt buckles, in many instances are made to resemble old silver by a dull dark finish. Others have bright surfaces while others again show a bright finish with oxidized shadings.

* * * * *

NEW silver buckles are out in floral patterns, and there are some attractive buckles formed of silver cords and chains ingeniously knotted into the required shape.

* * * * *

NUMBERED among novelties are studs and earrings of silver, finished to simulate black pearls.

* * * * *

BROOCHES of gold and silver, finished with dull black enamel, are popular for mourning, as are oblong and round forms in onyx.

* * * * *

FOR half-mourning toilettes, ladies wear a variety of jewelry including hairpins in all-white or lavender enamel; grey pearls, mounted so as to conceal the gold setting and dull finished and heavily oxidized silver ornaments.

* * * * *

ONE sees now-a-days a great deal of flexible jewelry, bracelets that cling to the arm, necklaces that adjust themselves to curves and undulations of the throat and neck, and corsage pieces that may be fitted to the requirements of the bodice.

* * * * *

SOME very pretty things are to be seen in the way of garnet jewelry.

* * * * *

A FLEXIBLE gold chain bracelet that claims attention has a rose diamond padlock, that locks; the gold key is suspended from the bracelet by a tiny gold chain.

* * * * *

THE insatiate demand for small presents in silver has been met with a wondrous variety of patterns in the form of book marks and envelope openers which sell at from one dollar to five dollars apiece.

* * * * *

THE double heartsease bracelet is a pretty ornament. It consists of a circlet of gold entwined with the long slender stems of two flowers which meet on top of the bracelet.

* * * * *

A NEW color this season in leather goods is pearl-gray. Purses,

blotters and card cases continue to be relieved with silver ornamentation.

* * * * *

A CURB chain bracelet that fastens with a hook and staple, is counted among the novelties.

* * * * *

BANGLES are very delicate and pretty, especially a gold one with two gold mice nibbling at a golden bit of cheese, and a platinum and gold curb, with a moonstone and diamond heart attached.

* * * * *

WHETHER as a brooch or bracelet the button hook jewelry is decidedly pretty and convenient.

* * * * *

THE orchid which is enjoying a wide spread popularity among florists, is just now a favorite model in jewelry. A flower brooch recently seen consisted of a cluster of orchids, perfectly reproduced in enamel, with sapphires to give them color.

* * * * *

PARMA violets are favorites in jewelry where they often have a diamond dew-drop to relieve the monotony of their lavender petals.

* * * * *

A BEAUTIFUL presentation brooch is one in which the diamond figures 1889 are interwoven so delicately as to half conceal themselves, while in the centre of each figure is dropped a single gem, either a diamond, emerald, amethyst, ruby, signifying "dear" in a graceful hieroglyph.



Art Glass and Ceramics.

PROGRESSIVE jewelers and silversmiths throughout the country now enhance the attractiveness of their stores and increase the numbers of their patrons by carrying, in addition to their regular stock goods of a kindred nature, such as art glass and ceramics and bric-a-brac of various descriptions, for the decoration of the "house beautiful."

* * * * *

CUT GLASS and potteries represent popular goods throughout the length and breadth of the land. Wide-awake jewelers are furnished with a sufficiently diversified assortment to include not very fine specimens of the most expensive wares for their exclusive trade, but articles that sell at from one to five dollars, to meet the requirements of that important and importunate army of shoppers who want something new and pretty at a moderate cost.

* * * * *

SINCE improved methods have placed American cut glass to the front and lessened the expense of its production, much of the table ware and other useful articles are now made in glass and afford a comparatively cheap substitute for silver, as well as a charming adjunct to it.

* * * * *

THERE is a fascination about handling cut glass, with its glittering

prismatic hues, that jewelers quickly experience—a feeling wonderfully akin to that which comes with the handling of diamonds. Connoisseurs in fine glass, as in diamonds, perceive, at a glance, if the glass be of true color, or rather, of no color at all, and if it has been cut and polished so as to gain the required diamond-like hues and brilliancy.

* * * * *

THE fact that the figures cut in glass must be geometric, prevents as great a diversity of patterns as is seen in etched and engraved glass. Very handsome designs have, however, been produced, designs which have rendered the clumsy old English patterns entirely obsolete.

* * * * *

EFFECTIVE designs noted are the rose-diamond, the sun, strawberry, passion flower, prism and bead, phoenix, pineapple and fan shaped cuttings.

* * * * *

IN THE more elaborate and costly pieces, a combination of patterns usually appears. Most of the pieces are finished with a scalloped edge, the fan pattern scallop being a favorite.

* * * * *

NOVELTIES in cut glass are individual flower globes which, as the name suggests are employed for placing before the plate of each guest. Butter tubs for holding little fancy pats of butter are also new.

* * * * *

IN PLACE of tall celery glasses, formerly in fashion, are provided a variety of horizontal shapes on which the celery stalks are laid. Similar shapes are also furnished for asparagus, while tiny little dishes with folding sides, are provided for after dinner coffee spoons.

* * * * *

INDIVIDUAL sugar and cream receptacles of cut glass are a delight to the housekeepers' heart.

* * * * *

OF SMALL odd pieces which may be employed for a variety of purposes, the number is legion and the shapes sufficiently diversified to please the most capricious. These irregularly shaped dishes are in many cases provided with handles and may be used for bon-bons, olives, cheese and the like.

* * * * *

A UNIQUE vase destined to attract attention, comes in what is called the pineapple pattern and simulates both the fruit and its foliage.

* * * * *

JUGS for whiskey and other liquors copy closely in form "the little brown jug," and have proven especially acceptable as presents from men to men. Caraffes are still made, but these divide popularity with glass pitchers and individual water jugs.

* * * * *

CUT glass is much used as presents for weddings. The conse-

quence is, one finds ice-cream sets, fruit sets, berry dishes and the like, in elegant cases after the fashion of cased silver.

* * * * *

ONE of the noted places of modern times in connection with the manufacture of glass, is Venice. Consequently Venetian glass is largely imported. This is represented in innumerable shapes, sometimes fantastic and quaint. Very beautiful are the liquor glasses, wide and shallow, with spiral lines of color in their tall thin stands. Equally beautiful are flower vases decorated with imitation precious stones, beads, etc., and known as jewelled glass.

* * * * *

NUMBERED with comparatively new claimants for favor, is the Belleek china made in New Jersey. This beautiful ware is noted for the delicacy of its coloring and its extreme lightness. In this latter respect, it may be said to rival the old eggshell of the Chinese. Especially dainty are the after dinner coffees, one dozen of which making 24 separate pieces, weighs only sixteen ounces, avoirdupois. The most striking pieces of the Belleek china are, however, large vases of artistic modelling and presenting richly elaborate decorations in enamels or gold relief and chasing.

* * * * *

WHAT is known to the trade as "art porcelain" ought to be in the show cases of all first class jewelers. This resembles the finest of carved ivory and comes in form of historic and classic heads, statuettes, busts, vases, etc.

* * * * *

THERE is always more or less demand for decorative pieces in Royal Worcester, Crown Derby, Sèvres, the decorative Hungarian and other choice and costly wares, the merits of which are too well known to require description here. It may be well, however, to mention in this connection, toilet articles and vases in Royal Worcester, with perforated edges and tops.

* * * * *

NUMBERED with what may be termed popular wares, in which small articles may be found that will sell at from one to five dollars each, are English-Hungarian ware, Staffordshire pottery, Imperial Crown, Leeds ware, Moorish Faience, Bonn ware, Sheppard ware Soudanese ware.

* * * * *

THE IMPERIAL Crown ware made at Carlbad, is characterized by its artistic shapes and delicate decorations, and is to be seen in form of bonbonnières, card receivers and other fancy pieces.

* * * * *

ENGLISH-HUNGARIAN, which comes in shape and decorations similar to the Hungarian, has the merit of being very much cheaper in price.

* * * * *

MUCH of the Staffordshire pottery is pleasing in its decorations and unique in its forms. Especial attention is drawn to the Adderley ware made in Staffordshire. This copies some of the effects

gained in Doulton ware, and is especially commended when represented in jardinnieres and other large pieces.

* * * * *

SHOWY and useful pieces are palm pots in Leeds ware,

* * * * *

MOORISH faience is remarkable for its artistic shapes, the decorations being both Moorish and Egyptian in design.

* * * * *

LARGE vases, urns and mantel pieces of Bonn ware, in tapestry ornamentation, are decidedly decorative in effect.

* * * * *

A UNIQUE ware that promises to become very popular, is introduced by the name "Soudanese." It is a species of Bohemian glass, being made in Bohemia. The shapes incline to bottles and jugs patterned after the Japanese gourd bottles. In these, two kinds of glass are intermingled, one representing in color and form a broken gourd, the other of some harmonious but contrasting color, filling out and completing the piece.

* * * * *

THE Sheppard ware which is represented in vases and urns, shows a granulated surface overlaid with a smooth decoration in another shade of the same color laid on in a sort of vermicelli pattern.

* * * * *

VERY pretty rustic stands of pottery simulate stumps and gnarls of wood in form and color.

ELSIE BEE.

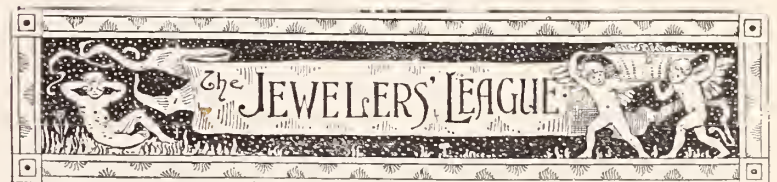

- President, HENRY HAYES.....Of The Brooklyn Watch Case Co.
 - First Vice-President, JAMES P. SNOW.....Of G. & S. Owen & Co.
 - Second Vice-President, ROBERT A. JOHNSON.....Of Celluloid Enamel Co
 - Third Vice-President, JOSEPH B. BOWDENOf J. B. Bowden & Co.
 - Fourth Vice-President, CHARLES G. LEWIS.. ..Of Randel, Baremore & Billings.
 - Secretary and Treasurer, WILLIAM L. SEXTON.....Of Sexton Bros. & Washburn.
- EXECUTIVE COMMITTEE.
- GEO. H. HOUGHTON.With Gorham Mfg. Co.
 - WM. H. JENKS.....With Tiffany & Co.
 - A. A. JEANNOT.....Of Jeannot & Shiebler.
 - GEORGE R. HOWE.....Of Carter, Sloan & Co.
 - WM. BARDEL.....Of Heller & Bardel.
 - J. R. GREASON.....Of J. R. Greason & Co.

At a special meeting of the Executive Committee of the Jewelers' League, held at their rooms on Friday, July 12th, there were present Vice-Presidents Snow and Bowden, and Messrs. Bardel, Greason and Sexton.

One application for membership was referred for investigation, six requests for change of beneficiary were granted, and the following persons were elected as members of the League: Henry F. Baker, Detroit, Mich., proposed by C. H. Morrison and F. E. Smith; Ernst Bechert, Corpus Christi, Texas, proposed by A. S. Freund and D. Hersch; Abram Brande, Philadelphia, Pa., proposed by J. Rosendale and A. Herzberg; M. Q. Lindquist, Red Wing, Minn., proposed by A. Krailsheimer and B. Chapman.

The next meeting of the Executive Committee will be held on Friday, August 2d, 1889.

Two Curiosities at the Paris Exposition.

IN THE war department is exhibited, among a great many interesting instruments, a *Phonotelemeter* invented by Captain Thouvenin. It consists of a watch with a curvimeter on its dial (fig. 1), of a mariner's compass on the *poussoir* (fig. 2), and of a meter telemeter placed on the back of the watch (fig. 3).

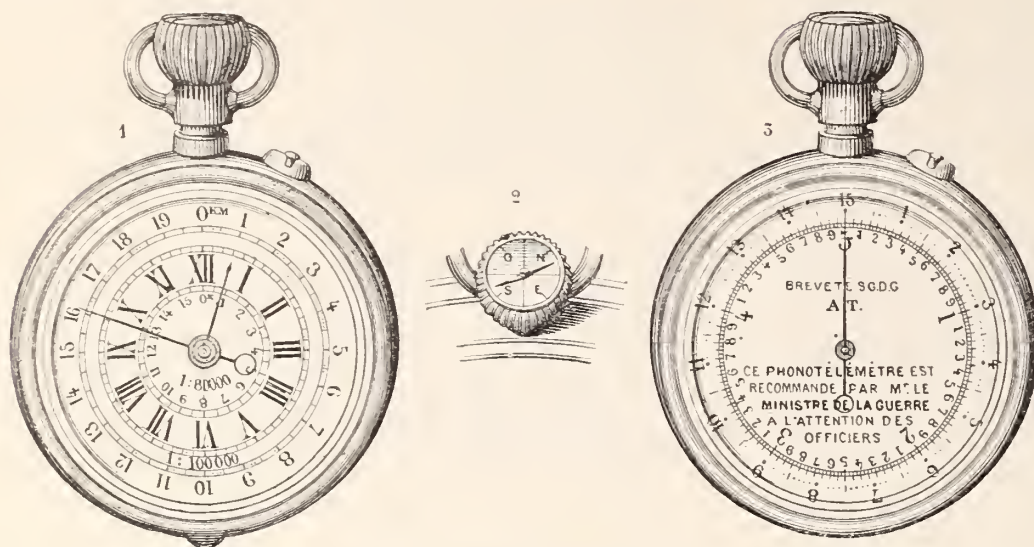

PHONOTELEMETER.

We need only describe the special parts of the instrument. On the dial are two graduations; one near the outside, corresponding to the scale which is on the map at 1-100,000; the other one, near the center, to that of the staff, at 1-80,000 (fig. 1).

To use it, you must bring the hand on OKM by moving a small wheel, and follow with this the space which you intend to measure, looking also at the graduation of the dial corresponding to the scale of the map on which the distance is to be ascertained.

As to the meter-telemeter (fig. 3), it consists of a dial divided into 15 seconds, subdivided into ten equal intervals, similar to the marks on fuses or guns, indicating time spent by shots, according to distance.

On the telemeter's dial, kilometers are indicated by the large black figures, 1, 2, 3, 4, 5; the hectometers by the little figures (in red on the instrument), the 50 meters by long marks between, and the 25 meters by short ones.

The watch being wound up and hung by the help of a spring pincers, on the side of a telescope or opera glass, as soon as you see a lightning flash or the light from a gun or from a fired cannon, you set the hand going by a gentle touch on the *poussoir*. You press it again at the very instant you hear the thunder, or the gun report, and at once the hand stops. An inspection of the graduated dial will then show you the distance inquired for, within ten meters. With this *phonotelemeter* the exact time can be made known to a tenth of a second.

In the section of horology which contains exhibits of Cl. Saunier, Rodanet, Paul Garnier, Gustave Sandoz, etc., is displayed a very curious watch made by Armand Schwob & Frères, which is classified under the category of timepieces known as "mysterious." It is made entirely of glass with the exception of a silver rim and the two hands, minute and second, which are moved as by some magic power. The watch is so transparent that one can easily read print through it. At first sight it is a perfect enigma to the beholder. If he manages to open it, the secret is partially revealed. Between the dial and the back which are made of plate glass, held together by a silver rim, another plate of glass is disclosed whose circumference has a rim of metal divided into regular dents or teeth. The axis of the hands passes through the plate, one end being fastened at its center and the other resting against the center of the dial. The inside

plate is set in revolution by a mechanism that is concealed in the top part of the outer silver rim, which is slightly wider at that place and shaped like a crescent. These revolutions of the plate transfer motion to the minute hand, which in its turn transfers motion to the second hand by means of a microscopic motion-work, hidden away at the center. The whole when shut is a great puzzle to the uninitiated.

By a close study of the explanatory illustration given below, the reader will readily understand the arrangement of the various parts of the mechanism. The fig. 1 represents the watch as it looks, the dial and all parts of the back of it being of polished glass. The fig. 2 shows the details of the mechanism, and the fig. 3 an enlarged profile. At C and C are the two front and back glasses; J is the dial; D the space in which the hands move; E, H, G, are the three wheels and pinion of the minute work; A is the center glass circle with a dented metal rim moved by the mechanism at the top, and F and B represent the two glass circles enclosing the revolving plate of glass.

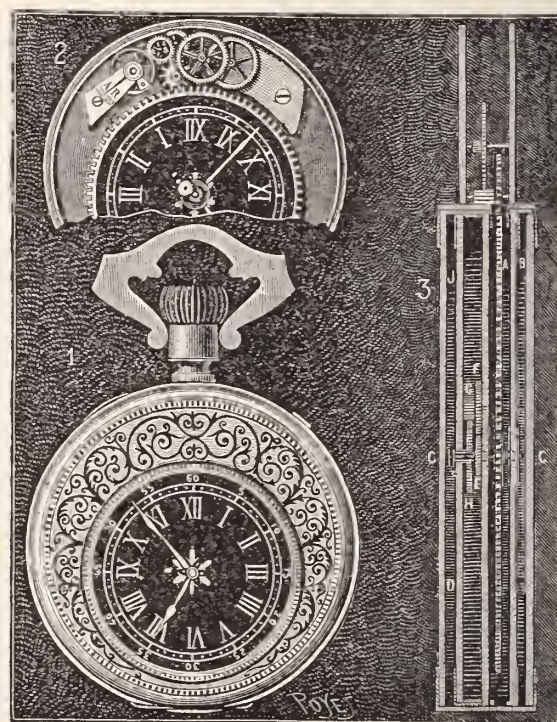

MYSTERIOUS WATCH.

ITINERANT JEWELRY STORE.—It costs something for royalty to make a tour of diplomacy among neighboring powers, the expenses of Emperor William's trip to Austria and Italy being not less than \$200,000. He took with him enough rich gifts to start a jewelry store, among them being diamond rings and bracelets, gold watches, scarf pins, presentation swords, and stars of the orders of the Black and Red Eagles.

LARGE AND RARE DIAMONDS.—Our French correspondent says that a large yellow diamond, larger than the Sancy, and valued at 160,000 francs, is very much admired in a store on one of the grand boulevards. In the same store is to be seen another black diamond valued at 90,000 francs. The two handsome baubles are surrounded with white brilliants, which set them off charmingly.

Advice to Watchmakers' Apprentices.

BY A MAN WHO HAS SPENT TWENTY YEARS AT THE BENCH.



BEFORE closing the subject of stem winding watches I will take up the matter of fitting new crowns. All watchmakers know how unpleasant it is to fit a new crown if it is a trifle too small. A chuck can readily be made to receive crowns so they can be turned out with the greatest possible ease and facility, by taking an ordinary cement chuck and fitting an addition to it as shown at fig. 1. In this cut, *A* represents an ordinary cement chuck, and *B* the added part. It is quite unnecessary to describe the cement chuck; suffice

to say it is cut quite short, leaving only about $\frac{1}{4}$ of an inch in the part shown at *B*. The part *a* which screws into the lathe spindle or rather into the lathe chuck which holds the cement chucks, is left of the usual length. The end at *b* has a screw similar to the one at *a* and screws into a disc *D* of heavy brass, shown at diagram *B**. This disc is fitted to the end of the short piece of tube *B*, and afterward *D* is secured onto *b* and turned true to fit *B*. The tube *B* is now soft soldered to *D*. A longitudinal section of the new chuck is shown at diagram *B***. The short pin of brass tube *B* should be about $\frac{3}{4}$ of an inch long and $\frac{1}{2}$ an inch in interior diameter; these dimensions leave the recess shown at *E* about $\frac{5}{8}$ by $\frac{1}{2}$ inch. To use our new chuck for turning out a crown, we fill the recess *E*, diagram *B*** with a plug of hard wood, and with a graver shaped as shown at *d*, fig. 2, turn a recess to hold the crown; the recess is turned to nearly the shape of the crown, as shown in fig. 2, where *G* represents the wood plug and *F* the crown. If the turning is done properly in the wood plug *G*, the crown will be held true and secure; if it should accidentally be turned a very little too large, dipping the

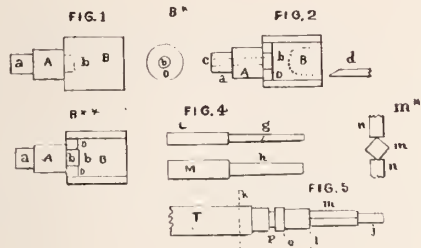

chuck in water will remedy the error. Such chucks can be used for a great many purposes. Rods of hard wood which will exactly fit *E* can generally be bought of the furniture makers for two or three cts. a piece. They are three feet long, so make a new winding arbor when the old one is lost; remove the dial of the watch and place the movement in the case and whittle a piece of peg-wood so it will extend into the movement of the watch, as shown in fig 3, where *H* represents a portion of the plate of the watch movement, *K* the pendant, and *f* the piece of peg-wood. By means of the peg-wood we can easily obtain the measurements of the correct lengths; the sizes for the bearings are best gotten at by measurements made with taper gauge. I do not think I can do the reader a greater favor than to describe a set of such gauges. Take two rings of steel wire; one size say about $\frac{1}{16}$ of an inch, the other $\frac{1}{8}$ of an inch, select such as fits the split chucks, as they run very true. The idea is to make a set of these with a slight taper as shown in fig. 4, where *L M* represents the two sizes of wire, and *g h* the taper parts. If eight sizes are made ranging from about .02 up to .11 of an inch in regular order, we will have not only a set of gauges but a set of round broaches to smooth out holes where we have bushed a barrel, or a center bridge. After they are turned in a regular grade, they

are hardened and polished. In hardening, dip them endwise into the water, then temper by drawing them to a straw color.

These pieces can also be used for arbors to slip on any piece to be turned. Such an arbor can be used to get the size of the crown arbor when it passes into the movement, as indicated at the dotted line *i*, fig. 3. In fig. 5 is shown the acting portion of a crown arbor, as the size to turn the pivot at *j* can be obtained by inserting the end of one of the round gauges into the hole where it belongs, and there turning the part *j* to nearly the proper size. The whole arbor is roughed out of that wire and then hardened and tempered to a spring temper. The wire *L*, from which the arbor is turned, is put into a split chuck, so that the part to the right of the dotted line *K* extends outward from the lathe chuck; we first turn the pivot *j* to the correct size, using a snap gauge as the instrument of measure. Such gauges are properly named *Douziemal gauges*. The part shown at *m* represents the square when the shifting wheel goes; the size to which this is to be turned is obtained by inserting a square file into the hole in the wheel, and measuring diagonally across the angles, as shown at diagram *m**, where *n n* represents the jaws of the snap gauge. The part of the arbor at *m* is turned to this size, leaving for the present the shoulder on the line *z* the full size of the wire. After *m* is of the correct size, we square the part at *m*. We push the holding pin into the division holes on our lathe at the quarter spaces, and set the tool rest so it is on a level with the arbor in the lathe; then with a sharp file guided by the tool rest, and the edge of the file by the shoulder left at *z*, we file the square *m*, one side at a time, until the shifting wheel will slip onto *m*. The part at *o*, where is the stone wheel with the round hole in it, is turned to match the size obtained by inserting one of the taper gauges shown in fig. 4 into the hole and then measuring the size with the snap gauge and turning the part *o* to correspond. The groove at *P* should be turned with a groove or a tool shaped to correspond to the groove. To briefly look over the process of making a crown arbor, we first select a piece of steel wire of the proper size, then give it a rough turning to approximate form, then take the piece of wire out of the lathe and harden and temper it. If the part at *o* should be overlooked and turned so small before we start to make the square at *m*; that it will not guide the file temporarily a washer of brass can be placed on *o* to guide the edge of the file. All the lengths are readily obtained by the pin of peg-wood, shown at *f*; the best way is to mark the peg-wood with a sharp knife at all the points from which to measure. The chuck shown at figs. 1 and 2, should have a hole in the direction of its axis as shown at *c* to admit a piece of soft brass to force out a crown if necessary.

LEATHER BRACELETS THE GO.—Leather is becoming quite fashionable as a material for making bracelets. First they began to put jewels on ladies' slippers, and the effect was so charming that some enterprising person at once caught the idea of ladies' bracelets made of fancy leather and studded with gems. The bracelets are made of soft ooze leather and the finest kind of kid in different shades of color, such as light fawn, brown, drab, black, dark red, and in fact any shade that will best harmonize with the stones to be set in the bracelet. The prettiest are of ooze in a delicate drab, flat on the inside and rounding on the outside, and studded with rubies and pearls. A silver cord guard chain is attached to the bracelet in the form of a true lover's knot, and the inside of the bracelet is lined with silver and bears an appropriate inscription for an engagement gift, leather bracelets being very popular for this purpose. Kid bracelets range in cost from moderate to large sums, but the cheapest of them are pretty and novel. They are generally in broad, flat bands, fastened with plain gold or jeweled gold buckles, sometimes ornamented with silver or gold thread worked in a delicate design on the leather and sometimes set with brilliants, emeralds, pearls, rubies and even diamonds. The lining is of gold, silver, silk or satin, and the stones are first set in gold in the design desired and then fastened to the leather.

Timing in Positions.



TO ADJUST a watch so that it has the same rate when placed first in a horizontal and then in a vertical position, says Cl. Saunier, is a delicate and often difficult operation; thus it is seldom found to be properly done in ordinary watches. It will be well here to summarize such of the directions as have a bearing on everyday work.

The rates in a vertical and horizontal position are made identical, or nearly so, by equalizing the resistances that interfere with the motion of the balance in the two cases, and by taking advantage of the displacement of the center of gravity of the balance spring.

Satisfactory results will be obtained in most cases by employing the following methods, either separately or with two or more together, according to the results of experiments or the rates, and the experience and judgment of the workman:

1. Flatten slightly the ends of the balance pivots so as to increase their radii of friction; when the watch is lying flat, the friction will thus become greater.

2. Let the thickness of the jewel hole be no more than is absolutely necessary. It is sometimes thought sufficient to chamfer the jewel hole so as to reduce the surface on which friction occurs; but this does not quite meet the case, since an appreciable column of oil is maintained against the pivot.

3. Reduce the diameter of the pivots, of course changing the jewel holes. The resistance due to friction, when the watch is vertical, increases rapidly with any increase in the diameters of the pivots.

4. Let the balance spring be accurately centered, or it must usually be so placed that the lateral pull tends to lift the balance when the watch is hanging vertical. In this and the next succeeding case it would sometimes be advantageous to be able to change the point at which it is fixed; but this is seldom possible.

5. Replace the balance spring by one that is longer or shorter, but of the same strength; this is with a view to increase or diminish the lateral pressure, in accordance with the explanation given in the last paragraph.

6. Set the escapement so that the strongest impulse corresponds with the greatest resistance of the balance.

7. Replace the balance. A balance that is much too heavy renders the timing for position impossible.

8. Lastly, when these methods are inapplicable or insufficient, there only remains the very common practice of setting the balance "out of poise."

If there is a gain in the vertical hanging position of the watch, slightly reduce the *lower* side of the balance; the vibration will increase somewhat in extent, and there will be a losing rate in this position. The contrary must be done in the opposite case.

When the vibration extends a whole turn, the changes will be the reverse of those above indicated. This fact must not be forgotten, especially in regard to the duplex and lever escapements, which may at first make a vibration of more than a turn, and subsequently less, according to the state of the oil.

We would again observe that the timing of a watch for position presents some difficulty, and it will only be after making a number of trials and studying articles on the subject, that the watchmaker will be able to accomplish it with certainty.

The Proportion of Balances.

TWO very important elements in timing are the weight and dimensions of the balance; it is, therefore, necessary that a watchmaker should practice himself in observing their relative values, and the effect of increasing one at the expense of the other in timing, and more especially in timing for position.

The *sensibility* of a balance to variations in the motive force, and

the time that elapses between the initial short vibration and the first that is of normal extent, a time that is approximately constant, will serve as a criterion. A balance that is very sensitive in the motive force is generally too small; and one that attains to the normal arc of vibration almost instantaneously, is, as a rule, too light. The contrary effects would indicate that the size and weight were excessive.

In order that he may be able to practically apply these remarks, the workman should gain experience by making observations on several watches the rate of which is known to be good, in the following manner. In regard to *weight*: Stop the balance at the position of rest of its spring, then release it and count the number of vibrations up to the point at which the normal arc is attained; the extent of this must have been previously recorded on the plate with rough marks. Record the number thus obtained in a table opposite to the dimensions of the balance, and, by comparing these dimensions with those of another balance of equal size, the weight can be ascertained and also recorded. In regard to *size*: Pass through the center pivot a kind of short screw arbor carrying a large, thin ferrule, on which a cord supporting a weight is coiled. Fixing the movement in a movement-holder, set it in a vertical plane, and observe the extent of the vibration of the balance with different weights attached to the cord. These arcs should also be recorded in the table opposite to the dimensions of the balance. With sufficient practice the watchmaker will be enabled to judge at a glance whether the weight and size are well proportioned.

The New Optical Glass.

THE READERS of THE JEWELERS' CIRCULAR will remember that a few months ago these columns contained a description of a new kind of glass for optical purposes. The article, based upon information gleaned from a European exchange, was fairly high-colored in its expectations from the virtues of the glass. These high expectations, however, have as yet not been entirely fulfilled, nor is there any prospect of their being so at a future time. The material was subjected to scientific tests, which demonstrated that these praises were altogether too flowery, although they also proved that the material possessed decidedly preferable virtues worthy of attracting the attention of scientific men.

C. S. Hastings, stimulated by these praises, instituted experiments with the glass, and published the results in the *American Journal of Science*. He obtained a piece of the material large enough to grind from it a telescope lens of $2\frac{3}{4}$ inches in diameter, and with it, he observed several celestial bodies, especially Saturn with his rings and satellites. He found that he could see with the $2\frac{3}{4}$ -inch lens about as far and as distinct as he could with the $3\frac{1}{2}$ -inch lens of the ordinary glass, and about 50 per cent. better than with an ordinary lens of equal diameter.

Although one may not yet be able with this new glass to see people in the moon, especially if none are there, nor see with it the "last atom," nevertheless the glass may be hailed as a valuable auxiliary for scientific observations, and it will assuredly assist in increasing our knowledge of things on this earth and other worlds. Another quality that makes it very valuable is that it does not refract the light as much as other glass does.

A SKULL AS A WATCH CASE—In the watch collection of Prince Soltykoff is a watch as remarkable as it is little and graceful. The case represents a skull, cut of rock crystal. This lugubrious piece of work was made by Jack Jolly in the reign of Henry III, which proves that not all the monstrosities were conceived during the XIXth century.



INTERESTING RESEARCH.—The well-known linguist and antiquarian, Dr. Max Müller, of the University of Oxford, recently delivered a highly interesting discourse in the Mansion House, London, on "Manners and Customs of the English-Speaking Nations," the origin of many of which could be traced away into the dawn of history. Thus, for instance, he pointed out that our letters were derived from the old Egyptian hieroglyphs, from which, be it stated, all the known alphabets, except the Chinese, are taken. Our figures also are very ancient. As is known, we call them Arabian, because we received them from the Arabians; and these people called them Indian figures, because they received them from India. Our figures, from 1 to 0, originated in India. These facts are sufficiently well known. Less known, however, is the fact that we are indebted to the Babylonians for our timepiece. The dial is a veritable piece of cuneiform writing. Why is the hour divided into 60 minutes, and each of these into 60 seconds? Simply because the Babylonians, beside the decimal system of counting, also used another—the sexagesimal—And why the number 60? Because the Babylonian merchants had found out that no other number has as many multiples as the number 60, which is therefore the most convenient for calculation. They divided the daily path of the sun into 24 parasanges which were equal to 720 stadia. Each parasange, or hour, was divided into sixty minutes, and corresponded, according to their views, to about the distance which a good pedestrian could accomplish in the same time. The 24 hours of the sun path were, therefore, divided into 720 stadia or 360 degrees. This system was introduced into Greece about 150 B. C. by Hipparchus, and 300 years afterward Ptolemy popularized it in Europe. Measures, weights, and coins were rendered into the decimal system by revolutionary France, which only halted in reverence before the Babylonian dial.

"OLD TIMER."—An admirably engraved and gilt toilet and voyage service of the time of Louis XIV. was recently sold at auction in the Hôtel Drouot, Paris. It had once belonged to Queen Maria Anna, Archduchess of Austria, spouse of Joseph I., of Portugal. The service, consisting of 19 pieces, brought 25,000 francs.

A WORTHY EXAMPLE.—Under the heading of "An example to imitate," the *Journal Suisse d'Horlogerie* says that the firm of Mermod Frères, watch and musical box manufacturers of Sainte Croix, imitating the example set by other houses of Geneva and elsewhere, have divided among twenty-eight of their workmen who complied with the rules and regulations governing the matter of participation, a sum of 5,000 frs., representing their share of the profits of the business transacted during 1888-'89. On the occasion of the jubilee—its fiftieth year of existence—this firm also divided a sum of 3,014 frs. among its old workmen, who are no longer at work under the present management, but who were engaged by former firms since 1839. "This," the periodical says, "is socialism of a sterling value."

WITHDRAWAL.—M. Hipp, so well and favorably known, not only in Switzerland, but also in all civilized countries, founder and head of the "Fabrique de telegraphes" and electrical apparatus of Neuchâtel, has, because of ill-health, retired from the active discharge of the business of this firm, but will continue, nevertheless, to assist his successors with his vast experience and talents in the construction of electrical apparatus. He will be succeeded by Messrs. Alfred Peyer and Albert Farvanger. The former gentleman was, until recently, director of the military workshops of the Swiss Confederation at Thoune; the latter is well known to the Swiss readers of THE JEWELERS' CIRCULAR, as having been employed for fourteen years under M. Hipp. It is rumored that this far-famed factory will, at an early date, be changed into a partnership concern.

HONORS.—On the 22d of May last, an imposing ceremony united the notabilities of horology and jewelry of the city of Paris, the occasion being the wedding of Mlle. Marguerite Rodanet, daughter of the president of the Syndical Chamber of Paris, with M. Georges Gilmer. It may be unnecessary to say that much jewelry of the most tasteful styles was displayed. The Chamber desiring to confer on the President and family a token of its high esteem, presented to the bride a handsome statuette of white marble.

PARIS EXHIBITION.—In the section of English colonies at Paris is a counterfeit of a lump of gold found at Ballarat, on January 5, 1871, and labeled £6,484. Its gross weight is 1,717 ounces.

HAT WITH EYE-GLASSES ATTACHED.—This invention, says *L'Industrie Parisienne*, is one of the most original which we had recorded for the past twenty years. Its object is to make the eye-glasses constitute a piece of clothing. It reminds us of the light with spectacles, invented by a dealer in *articles de Paris*, the success of which was very short-lived. By the use of them, the traveler could read at night in the railroad car. The spectacles were provided with a movable attachment, the nose serving as support; at the front end was a candle, which shed the light. The incommodity, the fatigue, which the traveler experienced, were great hindrances to their popularity. The hat eye-glasses are fixed in the interior of the hat, and the wearer may draw them down on to his nose, or push them up as he may so desire.

IVORY.—It has been known for years that ivory is getting scarcer every year, and the usual spring sale of ivory held at Liverpool on May 7, corroborates the fact. The use of it is constantly enlarging, while the elephants are getting scarcer, and ivory will soon be dearer than gold.

MALLEABILITY OF GOLD.—The round wire for the adornment of epaulettes, etc., is manufactured in England; but the bulk of the manufactured article finds its way in the shape of silky gold thread to India and the far east generally, where it is converted by skilled native labor into those gorgeous cloths and tissues in which the heart of the Oriental delights. What a wonderful property does gold possess in its malleability. To make this wire, bars of the metal are drawn from 100 to 150 times through ever-diminishing holes in steel plates, and finally, when the capabilities of this metal have been exhausted through apertures in diamonds, rubies, or sapphires.

CURIOUS WATCH.—A very curious watch is exhibited in the French horological section. It belongs to the class of timepieces called "mysterious," being entirely made of glass, with the exception of a silver border and of the two hands. Unless he finds the way to open it, the uninitiated cannot at all realize how it goes. Between the dial and the back, made of plate glass, is a glass circle with a metallic rim divided all around into regular teeth, which are moved by a mechanism, hidden in the top part of the silver margin which is slightly wider at that place. The pivot holding the hand is fixed on the middle glass through which it runs both ways, resting at once on the centre of the dial and on that of the plate glass back. The minute hand (which turns with the revolving circle) moves the hour hand by means of a microscopic gearing.

THE CLOCK OF THE BASTILLE.—On the occasion of the coming Exposition of Paris, an interesting and historic piece of ground has come into notice again: we mean the quarter of the famous Bastille. This celebrated prison had a clock, set up in 1764, in the body of the building that separated the two Courts of the Castle. It was made by one Sieur Quillet, clockmaker, who was also charged with winding it every day, for the sum of 150 francs per year, to date from March 14, 1764. This clock was ornamented with a scene entirely in keeping with the lugubrious purport of the building: two prisoners one a young man, the other an old man. Finally in 1783 these symbols excited the indignation of L'inquet, and M. de Bretenil, then secretary of state, had them taken down in 1783. The clock itself was taken away three days after the taking of the Bastille, and since then all trace of it has been lost.

WORKSHOP NOTES



TO POLISH A BALANCE STAFF.—The part of a balance staff requiring the most dexterity is the polishing of the slope. Many do this by resting the polisher on the arbor before it is turned down; but it is a far more workmanlike process to turn the arbor down to the proper size and to polish the slope simply by the "feel" of the polisher. The skilful "crossing of the grain" is a most essential point here. In polishing the front arbor the great thing to avoid is "getting a lump in the corner;" a small nick should be left from the turning so that the shoulder and arbor "come up" at the same time.

THE REPAIRER'S CHIEF RELIANCE.—In most works on watch repairing, elaborate directions are given for finding proportions and appliances for accurate productions, which, however valuable to the manufacturer, are useless to the repairers, as only a capitalist could purchase the requisite tools, and no single lifetime would be long enough to acquire skill in their use. The watch repairer must depend upon his file and mother wit for most of his success. His bow and turns, well used, will never be surpassed, and seldom equalled by the most elaborate lathe ingenuity can devise; and as these have been sufficient in the past to produce the highest specimens of the horological art, the repairer will do well to place his chief reliance upon them.

USE OF THE GRINDSTONE.—Considering how frequently it is used, the full virtues and use of the grindstone and Arkansas oilstone are not understood as thoroughly among watchmakers as it should. The best angle for cutting purposes is about forty-five degrees from the point backward, but it depends very much on the kind of work in hand. You can use a sharper point with light than with heavy work. For heavy work, you need strength in your cutter, as well as a good, strong bow, while for staff and pivot work a fine hair bow and slender point are desirable. Always be careful in sharpening your graver to carry a steady hand so as to have the face of your graver flat and both edges of equal lengths. This requires much practice, and you must learn to grind flat on the grindstone and preserve your surface and angles on the oilstone. The practice of whetting the sides of the graver on the point is to be avoided, although it may be done to a limited extent. But to turn a nice, square shoulder on a pivot, a sharp, diamond-point graver is very necessary.

EMERY GRINDER.—Shellac, melted together with emery, and fixed to a short metal rod, forms a grinder excellent for opening the holes in enameled dials. The grinder is generally rotated with the thumb and forefinger, and water is used to lubricate the cutting part, which soon wears away. The grinder is reshaped by heating the shellac and moulding the mass while it is in a plastic condition.

TO RIVET THE PALLETS.—The general way is to drive the pins into the pallets from the top side of the lever. By this means the largest ends are uppermost; but we was always taught to fix the pins in the pallets first, and after shortening them, to press the lever down on them, and then rivet the ends over with a suitable punch. By this means a "perfect fit" was insured.

TO STRAIGHTEN A PIVOT.—This may be done with an ordinary tweezers, or in the bearing of the pivot-burnishing tool by strongly pressing upon it with a dull, pivot-polishing file. Else, a small plate may be made with a number of holes of varying sizes; of this a suitable one is found for the pivot, and the latter is straightened in it by holding the wheel or pivot between the fingers; it may also be done with small punches with corresponding small holes; the operator must be very careful, however, not to bend too much.

SIZE OF LATHE.—Some watchmakers will put work to be turned in a small lathe, so as to have the screw collet on the right-hand side of the piece to be turned, and work at the left. There are some pieces where some advantage is to be gained by this, but although adopted as a rule by all workers, and many on the continent of Europe, we think the English method of having the collet at the left and working at the right more simple, and therefore preferable.

STEEL FOR POLISHERS.—The use of square steel for polishers was formerly regarded with disfavor. It is easier to make a polisher out of square steel; but on the other hand very much more important lessons may be learned by using round steel, and narrow polishers are preferable to broad, because the necessary movement on the arbor to cover the whole surface gives a freedom of touch which can be acquired in no other way. It is technically called "crossing the grain."

TRANSPARENT CEMENT.—According to a French journal, a good transparent cement may be made from the following recipe: Mix in a well-stoppered bottle, ten drachms of chloroform with twelve and a half drachms of non-vulcanized caoutchouc in small pieces. The solution is easily effected; when finished, add two and a half drachms of mastic, and let the whole macerate from eight to ten days, but without heat. The product produced is perfectly white and very adhesive.

TO MOUNT A WATCH.—After having cleaned a watch, and when you proceed to mount it, remember four rules: 1. Never handle a piece more than you can help; 2. Seize it with the tweezers, or handle it lightly with silk paper; 3. Hold it as short a time as possible between your fingers; 4. Use linen rags that do not defibrate. There are several kinds of paper that can be used advantageously in place of linen rags for drying and holding the parts.

ALLOY OF ALUMINUM AND TIN.—A useful alloy of aluminum and tin has been obtained by M. Bourbouzè, by melting together 100 parts of the former metal with ten parts of the latter. This alloy is whiter than aluminum, and has a density of 2.85, a little greater than that of the pure metal, so that it is not too heavy to replace aluminum in instruments requiring great lightness of their parts. It is less affected by re-agents, etc., than aluminum is, and is also more easily worked. Another of its merits is that it can be soldered as easily as brass, without any special preparation.

THE MEANING OF PITCH CIRCLES.—Saunier says, in regard to pitch circles: In every depth the *curved* portions, both of leaves and the teeth, which are known as the *points of curves*, always project beyond the pitch circles. In discussing any depth, we start with the supposition that if these two circles were to roll on each other without friction, the depth would be perfect or primitive. Hence, they are known as the *primitive geometrical* or *pitch circles*, and their diameters and radii are also called geometrical or primitive. Thus, in every wheel or pinion it is important to remember that the total diameter is the primitive diameter plus twice that of the point, or curve portion of the tooth or leaf.

MAGNETISM IN WATCHES, ETC.—It has been well settled that the springs of chronometers and watches, which are made of steel, are often magnetic. Steel is at all times liable to become magnetized, either by being carelessly brought within the circuit of a dynamo, or from other causes beyond man's control. Watchmakers are advised to test their springs as to magnetism by placing them near a very small and truly balanced mariner's compass. If the spring exhibits in none of its circumference any tendency to move to one pole of the compass more than the other, it may be considered free of magnetic influence; on the other hand, if the north pole moves to one part and the south pole to the other, the spring is decidedly useless; for in whatever position the timekeeper may be placed with such a spring, it will be affected by the earth's magnetism.

Electricity and Magnetism,*

AS AFFECTING THE PERFORMANCE OF WATCHES.

A brief statement of the general principles of electricity and magnetism with a review of the various ways in which they can injuriously affect the performance of watches, and of the different methods employed for preventing or remedying such effects.

BY "EXCELSIOR."

Continued from page 55, July, 1889.

Anti-magnetic watch cases act on the same principle as the shields and pockets before described—the body being made of iron, preferably in the form of "hunting cases," whereby the magnetism is led around the movements as just stated, instead of being allowed to pass through them. The writer was an early inventor of such cases. They can be made of iron alone, or iron tinned or "galvanized" over. But for general wear the writer once proposed what are called "filled cases," the filling or body being of iron, and the outside plating of gold, silver, nickel, brass (or more politely speaking, some sort of "oroïde," aluminium bronze, etc.), or any metal desired. I had special processes for hard-soldering the metal plates together, rolling them, stamping out the blanks, etc. The inner caps or domes and bezels were nearly all iron, the thickest plating being on the outside parts, exposed to wear. The stem was also of iron, plated, and the stem-winding and setting posts or levers were made of some strong and hard non-magnetic metal, such as the modern aluminium bronze. The explanation of the magnetic shields shows how these cases would protect the movement from magnetism, by surrounding it with iron.

Anti-magnetic movement boxes the writer also devised, of iron, tinned over—to protect the movements before being cased; of standard sizes for the principal grades of movements, with openings in the edges for the winding and setting pieces to pass through; and with or without pendants for hanging them up.

Anti-magnetic and non-magnetic devices.—The magnetic shields, pockets and cases might also be called preventives, but they are more properly termed protections, because they protect a watch which is susceptible to magnetism, and which without them would be liable to become magnetized, whereas the preventives are means or methods of removing this susceptibility or liability, and thus preventing magnetism from having any injurious effect upon the running of the watch. The former are "anti-magnetic," the latter non-magnetic. Thus a magnetic shield is an anti-magnetic device, while a watch not susceptible to magnetism is a non-magnetic watch.

Protection from currents and magnets.—Electric and magnetic apparatus are, now-a-days, found almost everywhere, and it is important to arrange them in such a way as to do us no harm, especially in your store, where tools and other objects as well as watches are liable to be affected. The only protection from the action of small magnetic apparatus is to surround it with an iron case or box. If the magnet is weak a box of ordinary tin plate may be sufficient; if stronger, use sheet-iron, or something having metal enough to conduct all the magnetism freely, and thus confine it in and within the casing. The box may be all metal, or partly of wood or other material, lined or sheathed with iron. When you are inspecting or using the apparatus, the cover can of course be removed; proper care should be taken and it should be replaced as soon as your work is done.

In a similar way, trunks or portable cases for watches, tools and materials, can be made safe for keeping them in, by being made wholly or partly of iron, as above stated. Soft iron is the best, but very soft cast iron or soft steel may answer, provided they do not retain magnetism. The kinds of iron or steel required, and the proper treatment, may be learned from any electrician. Whenever you are uncertain, use soft iron. Movement boxes should also be of soft iron.

Your watch-racks, portable or stationary, can be sheathed with sheet iron, or lined with it under the velvet, the hooks or fixtures running through it. Ordinary sheet iron is much improved for all of the foregoing uses by heating it red hot and cooling slowly, being careful not to hammer or work it afterward and make it hard again. Avoid touching the magnets with steel tools, etc., especially those used in watch work.

To neutralize the effect of a current in a wire, we simply offset one current against another, or arrange the same current so that in one portion of the wire it will neutralize the effect from another portion. This we can do by arranging the outgoing wire and the return wire near each other, and thus sending the current in opposite directions in the two wires, as shown in fig. 20, where the outgoing wire is marked +, and the return wire —. The current flows to the electric lamp *L*, (or any other piece of apparatus,) and back to the battery or dynamo. As the current is always of the same strength in every part of the circuit, it will be equal in both the + and — wires, and while one would tend to deflect the needle *NS* one way, the other would tend to deflect it the other way. The needle (or the watch, or other article susceptible to magnetism) being practically at an equal distance from each wire, and equally acted upon in two opposite ways at the same time, is not affected either way. The security of this arrangement is greatly increased by twisting the two

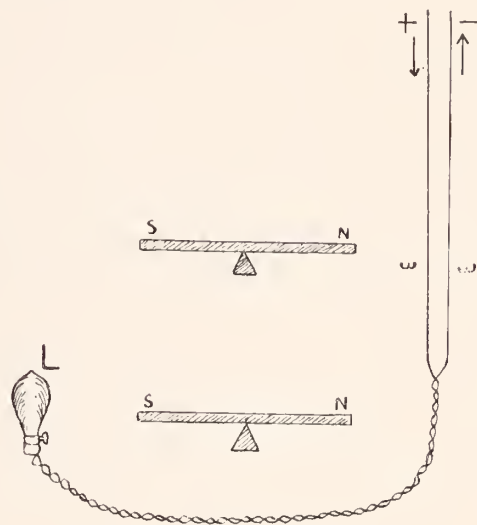

FIG. 20.

wires together, which should be done when practicable, as shown in the lower part of the figure. Of course the wires must be well covered with non-conducting material before twisting, to prevent contact between them, as the current would flow through the point of contact, instead of going through the lamp. They must also be kept dry to prevent current leaking through the insulating covering around the wires or between them.

Protecting the work bench from magnetism. Last, but not least in importance, is the method of protecting the watch bench, tools, etc., so that you may have a safe place to work in. In my first article I remarked that if you had a shop free from magnetism you were "a fortunate man—one among ten thousand!" It sometimes occurs, especially in iron buildings, that the metal work of the structure will act like our magnetic shields and conduct the lines of force (through itself) around the bench or shop, which is then practically free from magnetism. But generally there is the magnetism of the earth, if not that from iron objects or magnetic apparatus, to get rid of.

If our detector needles still "point," after you have removed all tools and other objects which could reasonably be suspected of throwing out magnetism, we must provide a shield for our bench. It need not completely surround the bench or workmen, but should be so arranged as to intercept the lines of force before they reach the bench, conduct them either over or under the bench to a safe distance on the other side, and there discharge them, to continue their onward course, *i. e.*, "complete their circuit." The general idea is

shown in fig 21, where the arrows at the left represent how the magnetic lines of force are thus intercepted by the iron screen 1, 3, 2, discharged at the right hand, and so conducted around the table or work bench *B*.

First test by the detector needles the general direction of the lines of force in the shop, or the portion to be protected. It is the same as the direction in which the needles point. In a wooden building, free from magnetic apparatus, it will be north and south; but in other cases it may be in any direction whatever, depending on the producing magnets or causes. Having found their direction, we arrange our sheet iron shield or shell in the same general direction. For instance, if the direction is substantially lengthwise of the bench *B*, in fig. 21, we erect two upright iron screens, 1 and 2, at the ends of the bench, and connect them by the most convenient course, as by means of the soft iron sheet 3 on the floor, making good clean metallic contacts between it and the upright screens 1 and 2. This may be done by wide laps, as shown in fig. 22, secured together by numerous tacks or nails driven through both, into the floor, or any similar way—the object being to avoid any openings or breaks in the magnetic circuit between 1 and 2. In other positions they may be well riveted together. Possibly it might be sufficient to connect 1 and 2 by 3 alone, on the floor as shown, or under the bench itself. Or it might be more convenient to run it overhead like 3*a*; or it may be necessary to use both 3 and 3*a*, thus constituting four sides of a sheet iron box without top or bottom. These sides or screens should be wide enough to intercept all the magnetism which could reach the bench, and have substance enough to conduct it freely.

Although lines of force repel each other laterally, when they are of the same direction, yet they are attracted by soft iron, which seems to overcome this mutual repulsion between them, brings them close together, and crowds a great number of them into a small body of iron. In this way an iron screen will clear the adjacent space of free

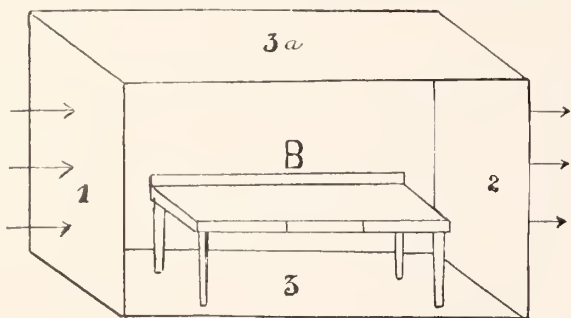

FIG. 21.



FIG. 22.

magnetism, even when it is not erected in the exact direction which the lines of force were previously following.

In case the lines of force run transversely across the bench, the problem becomes more difficult, as it would be very undesirable to have an opaque screen both before and behind the workman. In such cases, instead of a continuous screen, one having iron arranged around the border only, will often be sufficient to intercept the magnetism—just as if you should first erect the continuous upright screen and then cut out a window or large opening through it, in the middle, leaving the iron all around it. Whether this will answer the purpose, can only be found by trial, with our detector needles. If the task is too great, it will often be easier to change the position or location of the bench.

Doubtless some will laugh at all these precautions, just as they laughed at the idea of non-magnetic watches and anti-magnetic cases when I first proposed them many years ago, but it will only demonstrate their obstinacy, as in the former instances. I may add that one of the most conspicuously loud-mouthed decriers of the value of anti-magnetic devices, to-day, was also one of those who rejected them then. It is very hard for some people to learn anything new, however plain it may be.

Preventatives. Non-magnetic watches, the only preventatives now used, are those which are so constructed that magnetism does not

disturb them. The method of accomplishing this result which is at present in vogue consists in the employment of a non-magnetic alloy in place of ordinary steel, in the escapements, and especially for the balances and hairsprings. This at once overcomes the difficulty, for a metal which is non-magnetic is of course indifferent to the presence of magnetism—except that a balance of non-magnetic metal, vibrating in a magnetic field, might under some circumstances have a current produced in it. But, as shown in a previous article, there is really no danger from this source. If the escapement is non-magnetic, it is of little or no consequence whether the rest of the movement is magnetized or not.

The Paillard and the Waltham watch companies have made watches with such alloys for some time, and the Elgin company, as I am informed, have also secured a non-magnetic metal and have several thousand non-magnetic movements nearly ready for the market. Two other companies are publicly reported as making or about to make non-magnetic watches, and I know of four more companies which are experimenting with or negotiating for non-magnetic inventions. How many other companies are privately doing the same thing, and thus "getting under cover," I, of course, don't know. All these are in addition to the companies or firms using anti-magnetic cases, shields or other protecting devices alone.

We have now considered our subject pretty thoroughly, and I hope understandingly. Numerous details have necessarily been omitted, but a careful reading will suggest enough of them to the thoughtful workman to enable him to master our special topic. In order to understand "electricity and magnetism," he will of course need to study something further, and I would recommend every aspiring watchmaker to do so.

The principal question which will arise in the minds of those unacquainted with the subject is, Will magnetism really affect a watch so as to injure its running? We can now intelligently answer that question. As regards the latter branch of it, magnetizing a watch certainly will injure its running, unless it is anti-magnetic. And as for the first branch, we can now see that it is impossible for a watch to be exposed to magnetism without being more or less affected by it. Some claim that a watch will not become magnetized unless in actual contact with a magnet. That is absurd, for we know that watches are magnetized every day without having been in contact with any magnet.

Of course weak magnetism has less effect than strong, and it will require stronger magnetism to permanently magnetize the lever and hard parts than the balance, the steel of which is comparatively soft. That part, the most essential to be protected from external disturbances, is the very one most easily and most injuriously affected by magnetism. If a man lets his watch run down every other day, anyhow, an error of 5, 10 or even 15 minutes per day may not be noticed—provided it does not stop entirely. But if he takes any care of his watch, or any pride in it, and places any dependence upon it, then most assuredly magnetism is injurious. To appreciate this, it is only necessary to look back at fig. 1, and again follow out the explanations there given.

To Lap Old Gold.

WHEN you have gold of different qualities to refine you must melt it with saltpetre, putting in a little at a time, but using enough to have it boil while you are melting. When you think it has been melted long enough, let the crucible get cool enough to handle; break the crucible, and you will find the gold in the bottom. If all the copper and base metals are destroyed the gold will look clean; if your old gold was of low quality it will look white. You must now test it with nitric acid by something you *know* the quality of, to see how fine it is, and to bring it up to the standard you will have to add pure gold, putting in enough copper to make it of the desired color. If your gold was very fine you will only need to add copper

to bring it down to the desired quality. Suppose your gold *after* being refined is ten karats, then every pennyweight will have ten grains of pure gold and fourteen grains of alloy. Now, you wish to make it sixteen karats; to do so proceed as follows: Take one pennyweight of your gold ten karats fine and deduct the quality from the quantity: $24 - 10 = 14$; then multiply the quantity by the alloy, $24 \times 14 = 336$, divide this by the quantity of alloy there is in the quality you want $336 \div 8 = 42$, deduct the original quantity $\frac{7}{8}$ grains of pure gold to be added to each pennyweight of the gold you have.

Proof: Add together the amount, 24 grains, you had, with the 18 you have added, making 42 grains; multiply by the quality, 16 karats, divided by the original quantity, the product will show the amount of pure gold you have added with that which was in the original 24 grains, which you will find is 16 grains to each pennyweight.

24 grains, the original pennyweight;
18 grains added;

—
42
16 quality;

—
252
42

—
24)672(28 grains pure gold in the 42 grains.
672

This rule will apply to any quality you can buy of the dealer in jewelers' tools.

Accuracy of Certain Tools.

Drilling Tool.—To test the accuracy of the drilling tool, first center the runner in the turns, and ascertain that it is straight, cylindrical, and exactly centered; then fit a ring to it so as to slide with friction to (temporarily) limit the descent of this runner in the vertical stock of the tool.

After placing it in position, adapt to its lower end a collar, provided with a long index of soft brass, which is bent so as almost to touch the plate at its circumference. Rotate the runner, and it will be shown to be perpendicular to the plate, if the point in the index remains at the same distance from the plate.

As a confirmatory test, the runner may be drawn up in the stock, and the trial repeated after bending the index to nearly touch the plate.

Uprighting Tool.—If the two stocks or tubes that receive the runners are exactly in line, a runner should move easily through the two at once.

Setting the points in contact in various positions in a vertical line, observe whether they coincide, both when at rest and when rotated together, or independently.

First ascertain that the table is at right angles to the axis in the manner already explained for the drilling tool, making the necessary tests with the two runners independently. Then support between their points a short arbor carrying a soft brass index. The position of the lower runner being maintained constant by means of a collar as above explained, rotate the upper one by hand; its friction will carry the arbor and index around the point of this latter, being set close to the plate. Repeat the operation by raising the pair of runners and bending the index down to the same amount. If in these various positions the first remains at the same distance from the table, the tool is accurate.

An uprighting tool consists of two parts: the table carrying the lower stock, and the bridge that forms the upper stock. The base of this latter is a ring turned flat and coaxial with the stock, and is fitted accurately into a square groove surrounding the table, where it is fixed by screws.

Any watchmaker understanding this mode of construction will easily perceive when he has tested the tool in the manner above indicated, both what are its faults and how far he can correct them.

Alessandro Volta.



FEW months ago THE JEWELERS' CIRCULAR published in these columns the life of a man—Galvani—who had by his eminent invention contributed largely to the advance of art and science, and more especially the art of electro-metallurgy. On the 24th day of April, was celebrated a memorial day in the small village of Lazzarre, near Camnogo, in the vicinity of Milan, in honor of another scientist of the same class, Alessandro Volta. A memorial tablet was fastened to the house, which this learned man once had owned there, and in which he lived during summer, and where he had constructed his well-known "Voltaic Pile." Scientists from all parts of Italy, noblemen from the vicinity, old men who had known Volta, had collected there on the occasion, and the little town was literally "dressed in its Sunday clothes." Volta was by the peasants considered to be a wizard and magician, and the few still living who had been witnesses of his acts and doings recounted to the younger people many characteristic anecdotes. One of them said that he remembered very well when "Signor Lisander," as Alessandro Volta was called by his fellow-townsmen, requested him and a number of young people to clasp hands and arranged them into a chain, and when the Signor either touched them with his hand or cane, they fell down, then by another touch they would rise again. Another had seen "the magician" stirring with his stick into a quagmire, whereby bubbles arose to the surface of the water, which he caught in a recipient; with the contents of this he shot birds. Another time he immersed a burning candle in water, and left it in quite a while; when withdrawn, it still burned. One old man had heard him prophecy that the day would come when wagons and carriages would move about without horses, etc.

ALESSANDRO VOLTA was born at Como, of a noble family in 1745, and received an excellent education. In 1774, he was appointed professor of natural philosophy at Pavia, and continued to discharge the duties of this chair till 1804, when he retired to his native town to spend the rest of his days. Volta, while but a youth, had exhibited considerable taste for letters, and had even written two poems, one in Italian, the other in Latin, but as he grew older he abandoned such pursuits and devoted himself exclusively to the sciences, especially those connected with electricity. At intervals between 1777 and 1782, he visited Switzerland, Tuscany, Germany, Holland, France and England, making the acquaintance of the most eminent philosophers of these countries; and on his return he is said to have introduced the culture of the potato into Lombardy. In 1796, he was one of the deputation sent to solicit the forbearance of Napoleon, and was received with distinction by the French general, who afterward invited him to Paris to exhibit to the members of the Institute the action of the "pile" which he had invented, enrolled him in the Legion of Honor, and conferred on him the Order of the Iron Crown, with the titles of Count and Senator of the Kingdom of Italy. He was also elected (1801) a foreign associate of the French Institute, ten years after he had been made a Fellow of the Royal Society of London. He died at Como, March 5, 1826.

Volta's contributions to the science of electricity are of great importance, the chief of them being his theory, in opposition to the "animal electricity" doctrine of Galvani, that the electric power resides in the metals; although, in turn, he fell into the error of supposing that the chemical action of the different kinds of metals on each other was only incidental. He also invented an electric battery, consisting of a series of cups arranged in a circle, each cup containing a saline solution in which were immersed, edgewise, two plates, one of zinc, the other of silver, the zinc plate in one cup being connected with the silver one in the next by means of a wire. This battery, however, was soon after superseded by his "pile." He made various discoveries in electricity, the most important of which were communicated directly to the Royal Society in the form of Memoirs. A collection of Volta's works was published in 1816 at Florence, under the title, *Collezione delle Opere*, etc., 5 vols., 8vo.

Welding or Soldering by Electricity.



WE HAVE already, says *La Nature*, presented to our readers the processes of electric welding, devised by Prof. Elihu Thomson, of Lynn., Mass., and pointed out the numerous ways in which they might be applied. We will rapidly return to the subject in order to complete the technical details recently published, by the representation of the apparatus manufactured and used for the purpose by the Thomson International Electric Welding Co., at present exhibited and performing in the American section of the Paris Exposition.

The methods of welding by Prof. Elihu Thomson, in which alter-

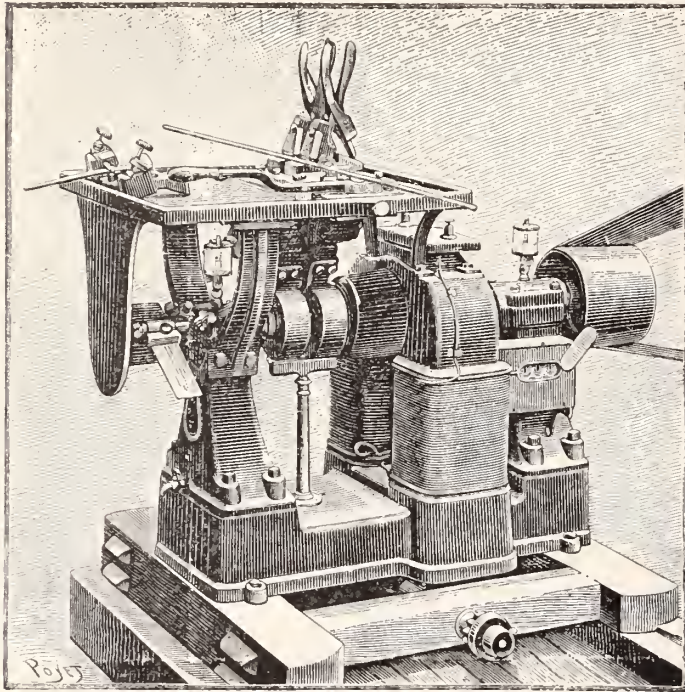

FIG. 1.

native currents are exclusively made use of, employ sometimes the *direct method*, when it concerns small pieces, sometimes the *indirect method*, for more important work.

In the *direct method*, fig. 1, the current is produced by a dynamo with alternative currents, furnished with two distinct bobbins, one being the principal, with alternative currents, the other secondary, furnishing a current for exciting the conductors. The principal current arrives directly at the pieces to be welded or soldered by two brushes rubbing upon the collectors mounted upon the axis of the machine, below the welding plate or table. The operator places the pieces to be soldered between two machines united by the brooms, places them close together mechanically, and raises the point of contact to the desired temperature, causing the excitation to vary by means of a rheostat intercalated in the circuit. When the desired result has been obtained, an arrester rapidly breaks off the circuit of excitation, and instantaneously prevents the generation of heat.

This disposition suffices for soldering wires, the diameters of which vary from $\frac{1}{2}$ millimeter to 6 mm. Beyond this, the operator must have recourse to the *indirect method*, fig. 2.

By the *indirect method*, he will overcome the difficulty encountered in generating currents of great intensity by the use of induction transformers. A machine with alternative currents of sufficient power—that working in the American section is of 35 kilowatts, excited separately—sends a current of an intensity variable with the excitation in the circuit inductor of a transformer stowed in the body of the apparatus shown in fig. 2. The circuit induced from this transformer, which forms only one coil or a small number of

coils, communicates with the jaws between which are fixed the pieces to be soldered or welded. The largest apparatus constructed at present (which is exhibited at the Exposition) can weld bars of iron of 5 centimeters (2 inches) in diameter, and produces a current up to and occasionally exceeding 50,000 ampères, with an electromotive force less than 1 volt.

The method as devised by Prof. Elihu Thomson possesses the great advantage of a wide range of application without being materially costly or cumbersome, over the old method of welding by continual current and accumulators. The quantity of 50,000 ampères, which we state, is not absolute, however; it is the maximum intensity found necessary to weld bars of iron from 5 to 6 centimeters in diameter, but with a more powerful apparatus, suited to larger work, it would not be difficult to obtain intensities from 100,000 to 200,000 ampères. At this point of view, the power of action of a transformer is well nigh unlimited, and the theory of the phenomena of induction is sufficiently well understood, so that the operator may in advance calculate all the elements of construction; these elements depend on his desire; for instance, how much time he wishes to spend in accomplishing certain results, etc. The duration of an operation of welding varies between one second and two minutes, according to the size and the nature of the pieces to be welded. From this will be seen that the process is very quick.

A very ingenious and simple electro-magnetic counter, fixed to one of the inductors of the alternative current machine, advances by one unit every time that the machine is excited, that is to say, each time that it is set into operation, and thus counts the number of weldings made per day, without the operator needing to take further notice of it.

The collection of weldings shown by the Thomson International Electric Welding Co. is really remarkable. The beholder will not only see weldings of iron and steel bars of all sizes (which is only in the infancy of the art), but also those of all metals which have up to the present resisted all attempts, and which could be soldered only by a brazing by means of some third metal; silver, copper, brass, bronze, lead, tin, zinc, platinum, aluminum, German silver, are soldered one to the other in a very heterogeneous order. In like manner are to be seen iron pipes welded together; covered wires are

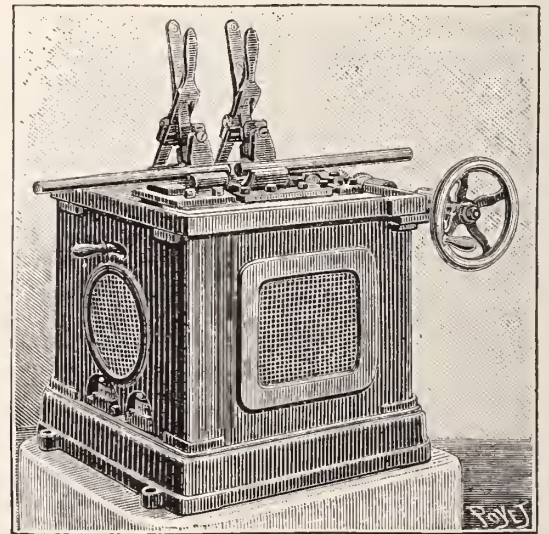

FIG. 2.

soldered together by laying them bare for a length of about 3 centimeters (1 inch) only; chains made from one or more metals, and a great number of other specimens, none less interesting. A detail of the results obtained by this process might perhaps be tiresome, and it is better to see the machine at work and note results. We would, therefore, strenuously advise our readers to visit the collections of marvels to be found in the Champs de Mars.



[FROM OUR SPECIAL CORRESPONDENT.]

ATTLEBORO, July 20 1889.

"Not a big season as yet, but still most of us are doing fairly well," is the answer received by THE CIRCULAR'S representative from one of the leading jewelers, when spoken to in regard to the present condition of the trade.

Time it is that most of the firms could easily do double the amount of business they are now doing, but still everything seems to have a healthy look. Not a shop in town but is running full time, although the benches are far from being crowded with workmen.

I have watched the business in this town and in this vicinity for more than four years, and at no time have I seen it with a healthier look. The men are satisfied; they are never anxious for "booms," for well they know that they always mean small orders to follow. The salesmen are meeting with very good success among the western jobbers, and they almost to a man feel that the outlook ahead is a good one.

ATTLEBORO.

I believe that for some reason the firms of this town are always the first to feel the ups and downs. I cannot account for it in any way whatever, but they surely do get the "booms" first and lose them first. Just now everything is moving along as smoothly as could be wished, and the prospect is good for continued prosperity.

The firm of G. H. Coggsill & Co. have dissolved, and E. W. Makepeace has withdrawn. The business will be carried on at the old stand under the old firm name by Mr. Coggsill, while Mr. Makepeace goes into business for himself. C. L. Watson, of the firm of Watson, Newell & Co., is very much interested in the success of the North Attleboro Steam and Electric Co., of which he is the President. The firm, over Mr. Watson's signature, have just made a proposition to put in gas pipes at North Attleboro, and supply the people of that town with illuminating gas at \$1.60 per one thousand feet.

C. A. Marsh, of the firm of Marsh & Bigney, has returned from a successful trip among the jobbers.

S. A. Butman, of Cincinnati, has recently been in town looking over the fall samples.

ATTLEBORO FALLS.

The assignee of the firm of Mason, Draper & Co., has sold most of the stock and fixtures of that concern, but as yet there has been no settlement of the firm's affairs.

NORTH ATTLEBORO.

This decidedly prosperous community is congratulating itself on the near prospect of excellent facilities for reaching the outside world. The extension which is being made to the branch of the Old Colony road through this town and ultimately to Boston is being rapidly pushed, and Engineer S. L. Minot, under whose immediate supervision the work is being done, told me this week that it would probably be in running order by December 1. The electric street railway which is to connect Plainville with Attleboro, running through the main street of this town, is now well under way, and in six weeks it will probably be finished. Both of these schemes will be of great practical benefit to the town, and will probably attract new business.

The Wamsutta Hotel, which has been closed for several months, is about to be opened, and after August 1 traveling men can find a place to put up.

The following notice has been sent to the trade this week: "The co-partnership heretofore existing between Frank Mauser, Frank O. Coombs and Henry R. Franklin, under the firm name and style of Frank Mauser & Co., is this day dissolved by mutual consent. Signed, Frank Mauser, Frank O. Coombs, Henry R. Franklin." Mr. Franklin retires and the remaining partners will continue the business at the same stand.

O. L. Coombs, of the firm of Clark & Coombs, died Wednesday, July 3. He was well known and highly respected by the trade, as well as in North Attleboro, where he had lived since 1861.

MENDON.

The Opening of the Dueber Factory.

CANTON, OHIO, July 16, 1889.

Yesterday was a great day in the history of Canton and Stark County, and, in fact, of Northern and Eastern Ohio; a day that will be remembered as the one that saw the inauguration of the great Dueber watch case industry of this city, as August 11, 1888, saw that of the great watch movement factory on the West Side.

It being so desired by those directly interested, business was immediately commenced with a will, without the pomp and banquetting that characterized the opening last year. Fully four hundred men, together with all their foremen but one, at once set to their duties. The remaining hands are constantly arriving, and it is expected that the force, numbering about 1,000 souls, will be complete in a very short time. The heaviest arrival in numbers, those from Newport, will be here during this week, so says Mr. Dueber. Thus, soon this enterprise, together with the Hampden works, now employing nearly 1,000 persons, will between them, it is expected, be giving work to 2,000 people. It is the intention of the management to give employment to a number of Cantonians in the case works. Altogether, July 15 may be put down as a red letter day for Canton.

In addition to Manager Moore in the office are head bookkeeper E. Bush, entry clerk Max Loebintz, storekeeper William Joseph and paymaster Fred. Jones. Mr. Moore comes from New York and will take up his residence with his family in this city. Besides General Superintendent Detmering and Master Mechanic Bradley, there are foremen of the several workshops as follows: Metal department, press room, gold turning department, silver turning department, crown department, joining department, spring department, polishing department, gilding department, engine turning department, gold engraving department, finishing department and inspecting department.

The first delivery of gold and silver bullion has already been made. It consisted of \$10,000 worth of the precious metal, the gold being in 2½x1½x1½ inch bricks, each worth \$601.57, and stamped with the American eagle weight mark. The bricks came in a box from Colgate & Co., New York, via the Adams Express. The silver bars came in an iron-bound chest; each bar is worth \$200.

ARBOR HOOK.—The French pendule clock makers have the senseless habit of making the spring-arbor hook as projecting as possible, as if experimenting to find out how much the spring is able to resist. I can ascribe the proportionally few breakages of such springs only by the reason of their great breadth and thinness, which also protects them against undue expansion, conjointly with the gum-like lubricating oil, which protects them against any injurious effects of friction in its coils. Finally is the careless treatment and the putting in of the spring with too small a core often the reason for a subsequent breakage.

Obituary.

ORIN L. COOMBS.

On Monday evening, July 1, Orin L. Coombs, of Clark & Coombs, Attleboro, Mass., was stricken with apoplexy while walking in the yard of his residence. He became unconscious and died on the Wednesday following, his death removing an esteemed and industrious citizen from the community.

The deceased gentleman was born on August 28, 1827, at Northbridge, Mass. Arriving at manhood he learned the jewelry trade with Daniel Evans of Attleboro Falls, and was at one time foreman of the burnishing room of the Gorham Manufacturing Co. Moving to North Attleboro in 1861, he, after a short service with W. D. Whiting, formed a partnership with William Clark, their object being to carry on business as burnishers. Later he became foreman of the burnishing room of the newly formed Whiting Mfg. Co., which position he held until 1875, when he again formed a partnership with his old associate, William Clark, under the style of Clark & Coombs, for the manufacture of jewelry. The business has been successfully conducted ever since.

Mr. Coombs was an eminent example of a faithful, diligent and honest business man, as well as a loving husband and father. Mr. Coombs leaves a wife and a son, Frank Orin Coombs, a member of the firm of Frank Mauser & Co.

EBEN CUTLER.

On the 28th of June, Boston lost one of its oldest jewelers, in the person of Eben Cutler, who in his day, which was almost two score years ago, was widely known in jewelry circles, and whose figure will be favorably recollected by his contemporaries who still experience the trials and triumphs of jewelry manufacturing. Mr. Cutler was born in Warren, Mass., in 1816, thus making him 73 years of age at his death. He went to Boston at an early age and engaged with his brother Amos in the jewelry and watch business on Washington street, near Franklin street. Amos, who was a practical watchmaker, looked after the repairing business, while Eben took charge of the business details. After continuing in business for several years, they sold out to Dodge & King, but shortly commenced business again. About 1852 they sold out again, this time to Abraham Hughes, and retired from the jewelry trade. Eben then went to Europe, and on his return, became interested and achieved considerable prominence in politics. He was in the convention that nominated Abraham Lincoln for President, and was afterward elected Representative from Boston to the Massachusetts Legislature, serving in sessions with Governor Bullock, Caleb Cushing and Harvey Jewell.

RICE SHARPLEY.

One of the oldest and best known jewelers of Montreal, Canada, passed away in the person of Rice Sharpley, at the age of 85. When the century was still young he had been in business in London, and coming to Montreal, established a store in St. Paul st., then the principal retail business thoroughfare of the city. He continued in business with varying fortune till his death, his store on St. James street being fitted up in elaborate style, and containing, in addition to the finest jewelry, an excellent stock of fine art goods.

DAVID BLOCK.

Doubtless many of our readers will recall to mind the genial personality of David Block, of the old house of Block Bros., whom death claimed for her own, on May 30 last. Last year, his health being not strong by reason of a lung trouble that affected him, he determined to relinquish all ideas of business, and took up his residence in Paris. About two months ago, he was taken thoroughly sick, and died at his home 15 Avenue d'Jena, after but three days illness, at the age of 63 years.

David Block while yet a very young man, and rather poor, came

to America, and shortly afterward found employment with Charles Rubens, then a well known watch importer. Fortune smiled upon the young man, and at the expiration of five years, having mastered the business, he together with his brothers, Samuel, Theodore and Jacques, established the firm of Block Bros., at 76 Nassau st., with a factory at Chaux-du-fonds. David and Samuel took charge of the office, while Theodore and Jacques looked after the factory. Success attended these brothers throughout their business career, and in 1884, having acquired considerable money, they concluded to retire and sold out to Adolphe Schwob.

The deceased ever enjoyed a reputation for sterling integrity and honesty among his business associates.

JOHN KLEISER.

John Kleiser, one of Toronto's pioneer jewelers and watchmakers died on July 15, at the age of 65. Mr. Kleiser had been in the jewelry business on his own account since 1852, and had become known and universally respected in the trade from one end of Canada to the other. He learned his business with J. G. Joseph & Co.



[THE CIRCULAR is not responsible for the opinions or statements of contributors, but is willing to accord space to all who desire to write on subjects of interest to the jewelry trade. All communications must be accompanied by a responsible name as a guarantee of good faith. No attention will be paid to anonymous letters. Correspondence solicited.]

Ashland, Pa., July 22d, 1889.

To the Editor of the Jewelers' Circular:

Can you give me a recipe for polishing the cones and pulleys of an American Lathe. Please publish in your next issue.

A SUBSCRIBER.

[Mix oil with saphirine just sufficiently to wet it; then with a soft cloth, such as flannel, apply the mixture to the pulley while revolving. Powdered Tripoli can be used instead of Sapherine, but it is not so fine. The Saphirine costs 25 cents per bottle.—ED.]

BACK NUMBERS TO SELL.

River Falls, Wis., July 19, 1889.

To the Editor of the Jewelers' Circular:

I have THE CIRCULAR bound in full sheets, in good order, which I will sell at \$3.25 per volume. Have vols. 1878, '79, '80, '81, '82, '83, '84. Have other volumes up to date, but not bound; will sell them at \$2.00 per volume.

C. F. WINTER.

KIND WORDS.

Adrain, Mich.

I would not "keep store" without it.

WM. M. SHELDON.

New York, July 6, 1889.

I desire by all means to continue THE CIRCULAR for another year.

A. E. APPLETON

Warren, R. I.

Send CIRCULAR as heretofore. I don't expect to discontinue it as long as I live.

W. S. MILES.

Wyoming, R. I., July 19, 1889.

Your CIRCULAR is the best thing under the sun. Keep it coming.

A. M. OLNEY.



*** A Complete History of Watch and Clock Making in America.**

[By CHAS. S. CROSSMAN.]

Number Thirty-Six.

Continued from page 83, July, 1889.

WATCH CASE MAKING.

KELLER & UNTERMAYER.



KELLER & UNTERMAYER, 192 Broadway, manufacturers of fancy decorated gold cases, commenced to make cases in 1880, having previously been engaged in the wholesale jewelry line in Chicago and New York. Alexander Keller and David Untermeyer were the original members of the firm, which was augmented later by the admission of Henry Untermeyer and S. Aufheiser. Their first factory was located at the corner of Beekman and Gold streets, where they began to put upon the market the raised ornamented cases that have since been identified with their name. At first they encountered many obstacles, but by dint of persistence they educated the trade up to their standard, and now they are the largest manufacturers of encrusted and ornamented cases in the country, a single case of their make frequently costing upwards of \$1,500. In 1885 they were compelled by rapidly increasing business to move their factory to more commodious quarters, which they found at the corner of Barclay and Washington streets. Here they occupy three floors, covering 28,800 square feet and employ about 125 hands solely in the manufacture of fine ornamented and engraved cases. The large gilt sign which adorns the top of the tall factory is a conspicuous object from the ferries and steamers plying the river. On the 1st of January, 1889, E. Untermeyer, who had been on the road for a number of years in their interest, was admitted a partner, and in May, of this year, the New York office was moved from 9 Maiden Lane to the new Corbin Building, corner of Broadway and John street, where they have a large and handsome suite of offices adequate to the demands of their growing business.

BATES & BACON.

Bates & Bacon, manufacturing jewelers, of Attleboro, Mass., commenced to manufacture filled cases in the summer of 1883, under the patent of C. K. Colby, on a snap bezel, the special feature of which is that the pendant is attached to the rim holding the movement, which is in the outside case. They also make a regular line of filled cases. The concern has prospered and is now one of the leading manufacturers of filled cases in the country, employing over 200 hands. Their "Gem," "Favorite," "B. & B." and "Peer" cases are among the most popular in the market. Their factory, which is the largest in Attleboro, is a well-lighted structure, adapted to the branch of business carried on in it. The New York office, at 196 Broadway, is in charge of George M. Bacon, of the firm.

PAUL A. JEANNERET & CO.

When E. A. Jeanneret, 173 Broadway, sold out his business to Victor Nivois in 1884, three of his employees, Paul A. Jeanneret,

Louis Hilbert and J. Ludlam branched off for themselves and started a shop at 75-77 Nassau street, to manufacture gold and fancy cases. Ludlam subsequently withdrew from the firm, and the business is now carried on at the same place by the remaining partners, P. A. Jeanneret and Louis Hilbert.

COLBY & JOHNSON.

In 1879, Colby & Johnson, jobbers, began the manufacture of celluloid watch cases under a patent of C. K. Colby, of the firm. Their product consisted entirely of 18 and 16 size open face, but after about 25,000 of them had been made the enterprise was abandoned on account of lack of support from the trade. It was claimed for this case that, being dust-proof, it protected the movement from any injury by the penetration of dust or moisture, and they are said to have been favorites among practical watchmakers on that account. Quite a number are worn to this day.

(To be Continued.)

The Jewelers' and Tradesmen's Company.

GILBERT T. WOGLOM, *President.*

THOMAS A. YOUNG, *1st Vice-Pres.*
SHUBAEL COTTLE, *2d Vice-Pres.*

EPIHRAIM S. JOHNSON, Jr., *Sec'y.*
SAMUEL W. SAXTON, *Treasurer.*

BOARD OF DIRECTORS.

- JAMES A. SMITH, M. B. Bryant & Co.
- EPHRAIM S. JOHNSON, Treasurer, E. S. Johnson & Co.
- SAMUEL W. SAXTON, President Solid Link Chain Mfg. Co.
- CHARLES A. FOWLER, Fowler Bros.
- JOHN C. DOWNING, Downing & Keller.
- SHUBAEL COTTLE, President S. Cottle Company.
- THOMAS A. YOUNG, Ex-President National Association of Commercial Travelers ;
Chairman Legislative Committee and Vice-President of the Commercial Travelers' Ass'n, State of N. Y. ; President Traders' and Travelers' Union.
- CHARLES F. ROBERTS, M. D., *Medical Director*, 69 E. 54th St., N. Y. City.
- SAMUEL A. BALDWIN, W. E. White & Co.
- GILBERT T. WOGLOM, Gilbert T. Woglom.
- WILLIAM B. KERR, Kerr & Battin.
- SAMUEL SONDEHEIM, Bruhl Bros. & Co.
- Counsel, JAMES M. HUNT, (of Rudd & Hunt) 31 & 33 Pine Street.

During the past month the following named have been granted certificates of membership: Wm. E. Bidwell, with Jas. H. Hart, John G. Fream, Fream & Lawrence, Philip W. Taylor, Brooklyn, N. Y.; Jesse A. Reed, Stamford, Conn.; James J. Mitchell, William H. Lyon, Newburgh, N. Y.; Sam'l Coxeter, with C. M. La Rue, Danbury, Conn.; Adam Heerdt, Stamford, Conn.; C. B. Hufnagel, Mount Vernon, N. Y.; Thomas Hart, Albert Shiels, A. J. Schippert, Jr., Tiffany & Co., Geo. Carrington Taylor, Taylor & Brother, Albert H. Oakley, H. D. Merritt & Co., of New York City.

The system of mortuary assessments of the Jewelers' and Tradesmen's Company is based on the incontrovertible fact that the cost of insurance advances as the age of each member increases.

In consideration of this fact, the rate of mortuary assessments is increased slightly on each member annually, but sufficiently to meet the increasing risk incident to the advancing age; thereby, the more aged members themselves pay for their increasing risk and are not a burden to the younger members, and stability is assured.

The vitality of the company does not therefore depend entirely upon the accession of new members, but is as well preserved by the ageing feature of its assessments. Members are, however, a feature essential to strength, and the management present the merits of the company to that end in an advertisement on another page, inviting the jewelers of the country to membership without entrance fee for a while longer.

With a present membership of 800 and growing rapidly, the closing of the charter roll of members is in the immediate future.

— IMPORTERS AND CUTTERS OF —
RANDEL, BAREMORE & BILLINGS,

DIAMONDS,
AND MANUFACTURERS OF

DIAMOND JEWELRY.

58 Nassau Street,
29 Maiden Lane,
NEW YORK.

1 Tulp Straal,
AMSTERDAM.

1 St. Andrews St.,
Holborn Circus,
LONDON, E. C.



TRADE GOSSIP.

—L. A. Cuppia, 42 E. 14th street, New York, on the 20th July sailed for Paris on a short business trip by the steamship *La Champagne*.

—S. F. Merritt, Springfield, Mass., is at present calling on the trade in person, and is displaying handsome and extensive lines of his well-known eyeglass holder.

—The popularity of the "Acme" lever button, made by Fred. I. Marcy & Co., is well illustrated by their advertisement, which appears in this issue. The eagle is still perched up aloft with wings spread.

—The largest importers of pottery and fancy goods in the city are L. Straus & Sons, 44 Warren street, from whose enormous though carefully selected stock jewelers can find no difficulty in supplying their wants in this line.

—Walter E. White, of W. E. White & Co., was stricken with facial paralysis last month, and for a time fears of serious consequences were entertained. We are pleased to report a decided improvement in his condition, and that he will probably return to business this month.

—A. G. Funck, Secretary of the Fidelity Watch Case Co., 192 Broadway, returned from his flying European pleasure trip on the 29th ult. much improved in health and ready to buckle down to business again. Mr. Funck is a flyer, whether he goes on business or pleasure.

—Lawson & Van Winkle, 11 Maiden lane, are preparing, in addition to their complete line of black onyx and hematite jewelry, a full line of enameled flower pins, both for the bonnet and the scarf. They also have special facilities for importing and repairing coral, which seems to be coming into favor again.

—A. W. Merritt has left the employ of his father, S. F. Merritt, the well-known eyeglass holder manufacturer, of Springfield, Mass., and has accepted an interest in the Merritt Mfg. Co., manufacturers of the Merritt type-writer. Now all of S. F. Merritt's sons, numbering five, are connected in some way with this company.

—M. B. Bryant & Co.'s three travelers, W. L. Supple, Lewis E. Smith and Frank W. Harmon, started out on August 1st for their respective territories, taking with them the finest stock of rings that the house has ever sent out. In the picturesque phraseology of Mr. Supple, who travels through the Northwest woods, "they are loaded for bear."

—A. U. Olney, Wyoming, R. I., has conceived a simple though effective mode of advertising. This consists of issuing to customers the Waterbury Watch Co.'s odd little pamphlet, "A Tale of Three Revolutionary Watches," with such sentences as "Specs from 20 cents to \$2," "Clocks put in order at a fair price," etc., written on the covers.

—The firm of Hirsh & Metzger, 7 Maiden lane, New York, has been dissolved, Veit Hirsh retiring. Martin Metzger continues the business, retaining the old office, where, with increased facilities, he is prepared to fill orders for all goods in the jewelry line. He makes a specialty of watches of all makes, and diamonds, of which he carries large lines.

—Jacot & Son have now one of the most attractive show windows in Broadway at their new store at No. 298. The large plate glass is artistically decorated, and the window is full of attractive goods. Within the store the immense stock they carry will supply all the demands of the trade for musical boxes, which are sold at prices to suit the economical spirit of the age.

—Welch & Miller, 171 Broadway, New York, in addition to their large stock of jewelry cases, have for sale a fine line of Japanese bronze boxes, which they recently imported. These boxes deserve the attention of the trade, both on account of their novelty as jewelry cases and their artistic finish. The firm is making also an assortment of boxes for side combs in sizes suitable to the trade.

—Chas. D. Pratt, of the Chas. D. Pratt Co., importers of jewelers' fancy goods, 36 Chambers street, New York, will return from Europe early in the present month, when the house will begin receiving and arranging, in their large show-room, those choice novelties that Mr. Pratt knows so well how to buy. Retailers who have been fortunate enough in seasons past to get the pick of these importations, will take an early opportunity to inspect the stock.

—It will be seen, by a reference to page 48, that it pays to handle the "Best Lever" button, made by Champenois & Co., 5 Maiden lane. The moral of the advertisement should be heeded.

—No better example of the success that rewards enterprise and energy can be found in the trade than the young firm of Hearn & Braitsch, makers of gold and silver cane and umbrella heads, 121 Broad street, Providence, R. I. In the short space of two years they have won a leading position among the manufacturers of these specialties. They will shortly illustrate some of their new patterns in THE CIRCULAR.

—Special attention is called to the novelty introduced under the name "Soudanese Ware" by Hinrichs & Co., 31 Park place, New York, who have obtained letters patent on the processes of its manufacture. This ware is a species of Bohemian glass, and offers opportunity for decidedly novel shapes, as well as a unique style of decoration. As it is decorative in effect and comparatively cheap in price, it is believed the "Soudanese" will be a great success.

—A new spoon pattern, the "Marquis," has just been put upon the market by F. M. Whiting & Co., the well-known silversmiths of North Attleboro. It is a simple but artistic design, and appears in spoons, forks and fancy pieces. Cuts of this latest design will be found on another page. For the better information of the trade it should be stated that the New York office of F. M. Whiting & Co. is at 857 Broadway. *Entrance around the corner at 25 East 17th street.*

—Foster & Bailey are always out with something new, rain or shine. They are indefatigable, and, as a natural result, one hears no complaints in their factory if he is fortunate enough to find Mr. Foster sufficiently at leisure to give him an audience. Their latest additions are a locket to keep count for games and to be used as a calendar and a new rolled plate glove buttoner, which they sell at an astonishingly low figure. "Mount Hope" and "Omega" are appropriate words to close with.

—A. C. Smith, after a three months' absence from the active management of the Non-Magnetic Watch Co. of America, has accepted the general selling agency for the entire product of that company. He retains the agencies of the Trenton Watch Co.'s products and the beautiful "Belleek" china of the Otto & Brewer Co., of Trenton, N. J. Visitors to New York are cordially invited to inspect the varied samples of these companies' productions at his pretty office, 177 Broadway.

—Chas. Van de Sande, who has been on the road in the interest of the jewelry trade for upwards of thirty years, has severed his connection with Henry Carter and started in business for himself at 198 Broadway, Room 6, under the firm name of Chas. Van de Sande & Co., his partner being his son-in-law, C. E. Moller. Mr. Van de Sande is widely known in the South, and his numerous friends in that section may look for him in September with a brand new stock of the most salable novelties.

—The July 6 issue of the *Daily Herald* of La Porte, Ind., contained a six-column illustrated article, descriptive and historical, of the well-known horological institute of J. R. Parsons, of that town. The illustrations comprise a portrait of Mr. Parsons, an exterior view of the new building, and interior views of two work-rooms. Persons desirous of having their sons practically as well as theoretically instructed in watchmaking, and apprentices desirous of finishing their trade, should read the article.

—A visit of inspection to the Phoenix Glass Co.'s show-room, 729 Broadway, New York, will repay connoisseurs in cut glass, whether they wish to buy anything or not. Here is in stock cut glass without color, like the diamond, and remarkable for its polish and the perfection of its facets. A number of entirely new patterns are to be seen, together with an endless variety of small pieces for the table. Especially effective and likely to please is the company's new pineapple vase, also their individual flower globes and unique liquor sets.

—The new factory of J. F. Fradley & Co., of Pearl and Frankfort streets, New York, by reason of its spaciousness, healthy location, fine light and cleanliness, should serve as a model to many of the smaller manufacturers of John street, Nassau street and Maiden lane, whose workshops are grimy and close. The factory occupies the whole top floor of a large building, the floor capacity being about 3,400 square feet. There are no surrounding house tops, and the large windows in the four walls, numbering twenty-five, admit a perfect light and a splendid supply of fresh air. Most all the machines are new and contain the latest improvements. The firm has gone largely into the manufacture of silver novelties, such as brushes, combs, mirrors, cigarette and match boxes, etc. A handsome line of gold novelties is also being made.

—During the last fiscal year 59 pounds of fine jewelry, paying a duty of \$1.50 per pound, were imported into Honduras.

—M. F. Charles, who was formerly in business at Fryeburg, Me., has bought out the business of W. E. Beard, Reading, Mass., and will continue the business at that place.

—Maxheimer & Beresford, 3 Maiden Lane, have taken the two rooms adjoining their shop on the third floor of No 3, and now occupy nearly the whole floor, an indication of growth and progress.

—A. Klingenberg, 37 Park Place, offers to the trade this fall a very large stock of artistic pottery and bric-a-brac. The European manufacturers have contributed their choicest goods to Mr. Klingenberg's stock, and a whole army of bisque figures stand with open arms ready for customers.

—Jas. Schawel & Co., 29 John street, New York, make a specialty of assaying gold and silver in lot for out-of-town houses. This is an old and conservative house, having been founded in 1866 by Simon Schawel. James Schawel, a thoroughly practical assayer, was brought up in the business and learned the profession from his father, Simon.

—The Rockford Watch Case Co. have added to their works a watch repairing department. They have as its head, it is said, a skilled watchmaker as there is in the country in the person of I. B. Scott, who has, at different periods, held responsible positions in the Elgin, Aurora and Rockford watch factories.

—In the window of Tiffany & Co. was displayed last month the tanned hide of "Chief Forepaugh," the erstwhile gigantic elephant. This elephant was ten feet six inches in height, weighed five and one-half tons, and was next in size to Jumbo. The hide averages about three-eighths of an inch in thickness, is of a reddish brown color, and will be converted into traveling bags, dressing cases, etc. The tanning process occupied five months.

—The hearing in the case of George W. Laughlin, Canton, O., against the city, asking \$15,000 damages for injuries sustained by a fall on the street, was given last month, and was suddenly and unexpectedly terminated. Judge Thayer, one of the attorneys for the plaintiff, arose, and addressing the Court, stated that the plaintiff was ready to quit the action, several witnesses upon whom he depended having disappointed him. The jury was then discharged. City Solicitor Pomerine said that the city would have to pay the costs incurred.

—Darling, Brown & Sharp, Providence, R. I., manufacturers of special machinery and tools, have applied for a patent on a center gauge and gauge for grinding and setting screw tools, having a table for determining the size of tap drills. This instrument can be put to numerous uses—gauging the angle to which a lathe center should be turned, the angle to which a screw thread cutting tool should be ground, the correctness of the angle of a screw thread already cut, etc. Watchmakers and jewelers should send for one of the patentees' illustrated circulars.

—E. R. Stockwell, the badge and medal maker of 19 John street, recently finished a very handsome Masonic jewel for presentation to District Deputy Grand Master B. B. Odell, Jr., of Newburgh, N. Y. It is highly praised by all who have seen it. It has three ornamented gold bars fastened upon a band of blue ribbon, suspended from which is a pendant wreathed in leaves of gold and silver combined. Inside of this wreath are the emblems of the order, a large solitaire diamond being suspended from the center of the compass. The dimensions of the jewel are six by two inches.

—Charles Leo Abry, 4 Maiden lane, New York, is issuing a comprehensive price-list of Vacheron & Constantin's watches, for which he is sole agent, containing complete descriptions of the watches—balance, escapement, lever, lever spring, jewels, center jewel, finishing, adjusting, patent regulator and special signs—and giving the prices of those fitting Waltham 14 and 18 size cases, Elgin 16 and 18 size, Elgin 0 and 6 size, and Swiss 12, 13 and 14 lines. The list contains full particulars of the XXIX, placed upon the market recently as a watch especially adapted for railroad use.

—A partial history of the first eight-day watch made in this country has made its appearance. The timepiece was manufactured for the late General Armstrong, of Rome, N. Y., by the late Charles Fasoldt, of Albany, N. Y., who finally disposed of the watch, and it afterward came into the possession of J. M. Orton, of Rome. Mr. Orton purchased it of a man who at one time was in the employ of General Armstrong. Mr. Orton sold the relic to George Marsh, of Dayton, Ohio; nothing has since been heard of it. Mr. Fasoldt was a very ingenious mechanic, and many people in the vicinity of Albany are wearing watches made by him over fifty years ago.

—Gus Fredericks, for the past thirteen years in the employ of Sweeney & Coombs, jewelers, brokers and dealers in exchange, Houston, Tex., has been admitted to partnership in the firm. The style of the new firm is Sweeney, Coombs & Fredericks.

—The "Shakespeare Bangle" has scored an astonishing success. This little novelty consists of an ordinary slender bangle, having some pat quotation from Shakespeare stamped around the outside. The quotations are generally quite apropos, and, in consequence, the bangles are in great demand for presents. But their popularity has led to a pretty general piracy on the part of makers of silver novelties. The holder of the design patent on this idea is Frank H. La Pierre, 18 E. 14th street, who notifies the trade in this issue that he will hold responsible hereafter all who manufacture them, as well as those who sell the pirated goods. Avoid complications by ordering your "Shakespeare bangles" of the inventor.

—"That is the handsomest vinaigrette in this city," said Mr. Bolt, manager of the repairing department at the Mermod-Jaccard Jewelry Company the other day, as he wrapped up the bijou and passed it over the counter. Miss Orth is the owner of this approved scent bottle, which is of English cut-glass, long and tapering in shape, square-cut at the sides, but with a rounding bottom cut in long rayed lines, the hipped top similarly finished and capped with a silver lid—first glance seemingly like many another long scent-bottle, but on examination easily recognized as unique in elegance and costly in workmanship, a fit trifle for the fair hands of an elegantly dressed woman in idle moments.—*Fashion and Fancy.*

—About two years ago Perry Smith, of Unadilla, N. Y., bought from R. & L. Friedlander, 65 Nassau street, New York, a watchmaker's lathe and other tools, amounting to \$125. Time passing and no payment forthcoming, the firm came to look upon the debt as simply a bad one, until it learned that Mr. Smith had boasted to several salesmen that he did not intend to pay for the goods. Then through Edwin L. Kalish a writ of replevin was granted on the ground of fraud on July 5, and the goods returned. A somewhat similar case was that of the same firm against Granat & Davis, New York, who failed last December. On July 1 the plaintiffs were granted a writ of replevin for goods amounting to \$300.

—Rich cut-glass is coming into favor with jewelers all over the country. It is peculiarly appropriate for wedding presents on account of its elegance and purity. An old established American firm, C. Dorflinger & Sons, 36 Murray street, New York, has attained to such a pitch of excellence in the manufacture of this beautiful product of the furnace and the graver, that their finest pieces rival anything the world can show in this line. Retailers selecting their fall stock, therefore, cannot afford to overlook the Dorflinger show-room in Murray street, where they will find a complete assortment of cut-glass ware appropriate to the season, which Mr. Martins, in charge, will take pleasure in expatiating upon.

—Perhaps the very oddest advertisement in this issue of THE CIRCULAR is that of Ludwig Nissen & Co.—a lithograph of Mr. Nissen's signature placed diagonally across a pale inky blue background. Any one familiar with Mr. Nissen's signature would recognize it at once, and so skillfully is the work done that the ink seems scarcely dry in the flourishes. Such striking originality in advertising, backed by push and enterprise, cannot fail to carry this young house rapidly to the summit of its ambition. It may interest the trade to know that Mr. Nissen is not yet through with Henry Adams, the clever diamond thief who was sentenced to ten years in Sing Sing through his untiring efforts. He is endeavoring, and with every prospect of success, to learn who were the receivers of the goods that Adams stole and expressed to New York. There would be fewer thieves if we were rid of these Fagins.

—Catalogue 10, recently issued by Bowman & Musser, the well-known jobbers of Lancaster, Pa., is that of spectacles and eyeglasses manufactured by T. A. Willson & Co. It is a beautiful little pamphlet, its cover being of white leatherette, and having the word "Spectacles," in gold script, stamped across its front. It is asserted that this is the first complete catalogue of the products of the above mentioned factory that has been issued by the jobbers who handle them. For that reason alone the pamphlet should be in every retailer's office. The book is profusely and finely illustrated; the descriptive matter is terse and comprehensive. The price list to the catalogue is sent under separate cover, sealed, in accordance with the firm's invariable rule to quote prices in sealed envelope only. This line of spectacles and eyeglasses has but recently been added to the firm's former lines—watches, chains, tools and materials—and they assure the trade that they give to this new department the same thorough attention to detail and the same methods of management which have characterized their business throughout.

—H. F. Barrows and family, of North Attleboro, are sojourning at Rangeley Lakes.

—John W. Miles, the manager of the New York department of the Meriden Britannia Co., sojourned last month at Coldville, N. Y.

—Chester Billings and J. C. Mount, of Randel, Baremore & Billings, have returned from Europe, having made extensive purchases in new goods.

—O. E. Hausburg, the agent for the standard watchman's clock, has moved from 71 Nassau street, New York, to a larger office in the Knapp Building, 41 Maiden Lane.

—The retail jewelers of Halifax, Nova Scotia, have formed an organization to be known as the "Retail Jewelers' Association." John W. Gabriel, of 17 Buckingham street, is secretary.

—Mulford & Bonnet, importers of precious stones, 21 Maiden Lane, have dissolved partnership, Mr. Mulford retiring. The business will be continued at the same stand by the other partner, Jacob N. Bonnet, who will keep on hand constantly as choice an assortment of precious stones as ever.

—Louis Strasburger & Co., importers of diamonds, 16 Maiden Lane, New York, issued last month a tasteful memorandum book that is well suited to have bulky orders inscribed in it. It contains a calendar and a complete fractional diamond price list, very convenient for reference. The book is bound in leather, the covers being mainly of very flexible celluloid. A neat card of the firm is printed on the front cover and enhances the beauty of the book.

—R. Blackinton & Co., North Attleboro, Mass., are putting on the market a line of bright cut or brilliantine silver goods that are creating a decided sensation. This beautiful work, which sparkles like the diamond, appears in lace pins, scarf pins, side combs, buckles, bangles and ear drops. Buyers should not fail to call on Mr. Morss, their New York representative, at 182 Broadway, and see this latest novelty from the Attleboros.

—Miller Bros. & Co., 37 Union Square, New York, have been actively preparing for the demands of the fall trade, and have now handsome new lines of lace pins, scarf pins, buttons, brooches, etc., containing numerous novelties. They are made in strictly 14-karat gold, are handsomely and variedly designed, and are either plain or ornamented with diamonds, rubies, sapphires, pearls and other precious stones. Their line of bangle bracelets is of particular excellence.

—By examining the advertisement of H. Mahler, of Raleigh, N. C., the reader will learn something that will be of interest to him. Mr. Mahler advertises a patented combination business card and ring gauge. It is simplicity itself in construction, being but a business card with graduated holes cut in it, these holes representing the standard ring sizes. The patentee furnishes these cards completely printed, with the exception of the name and the address, which the purchaser can have printed in spaces left blank for that purpose.

—Hipp. Didisheim, 83 Nassau street, New York, has his stock prepared for the fall season. This stock consists of extended lines of chatelaines of all descriptions, including the famous "Mignon" and "Gem," and containing the latest conceits in engraving and design; and a complete stock of the well-known "Nassau" fitting 4, 6, 16 and 18 American cases. A line of chatelaines of particular beauty is of oxidized silver, with either etching or raised work. B. Didisheim, of the firm, is in Europe, combining business with pleasure.

—In the salesroom of the Middletown Plate Co., 22 John street, New York, may be seen samples of several new and handsome lines placed by the company on the market for this fall. Trophies for sporting competitions are to be seen, consisting of cup with an extended stand, the base containing tokens of the sport, such as an anchor, cable and block, or a bicycle, etc.; also some handsomely designed nut bowls, several new tea services, a new line of waiters with bright cut floral designs and new border, ice pitchers porcelain lined, many new designs in berry dishes, dessert sets, consisting of sugar bowl and cream in rustic design and numerous other specialties.

—The reader will notice that the cuts in the advertisement of John A. Riley have all been changed. The new illustrations represent samples of new goods that Mr. Riley has prepared for the fall trade. The reader will not fail to note the beauty of the designs and the elegance of finish of these new goods, for they are representatives of as handsome lines of hair pins and side and back combs as this country produces. Mr. Riley's other lines, bead necklaces, miniature brooches, patent scarf holders, etc., are also noted for their excellence. All these goods are made in 14-k. gold or sterling silver, in plain or gem-ornamented designs.

—The New York Jewelers' Board of Trade will have its regular annual dinner in the third week in January next, at Delmonico's.

—The dazzling advertisement on pages 18 and 19, we are sure, will not puzzle anybody—not nearly so much of a riddle as the ring is. Everybody knows where to go to get the "Razzle Dazzle Puzzle Ring."

—The handsome chatelaine represented in the advertisement of the Sterling Co., of Providence, R. I. is a sample of an elegant and extensive line of sterling silver novelties and small ware that the company have prepared for the Fall season.

—The committee of The Board of Trade and the Jewelers' Association, held a conference last month, at which the Board by reason of its being incorporated agreed to admit members of the Association in a body or individually, free. Owing to a large number of the Association's members being out of town no response has been heard from them.

—N. Kauffmann, managing partner of the American branch of the firm of L. B. Citroen & Co., 21 John street, New York, informs us that he has received a very large consignment of diamonds of the firm's own cutting. If there is such a thing in the trade as buying at first hands,—surely, here is the chance. Mr. Kauffmann leaves New York for the west in the first week of August.

—S. F. Myers & Co., 48 Maiden Lane, New York, will, in a few days issue their publication, *The New York Jeweler*. It will contain among other new things, notice of the closing-out of a large stock of silverware and clocks, and description, prices, etc. of a new line of watches and cases. This publication which was originally a four-page sheet, has now sixteen pages, and has numerous paid up subscribers.

—At the 3d meeting of the jobbers, organized to alleviate the abuses to which they are subjected at the hands of certain manufacturers, the attendance was very satisfactory, a number of new members were admitted, and the name first adopted revised to the "National Wholesale Jewelers' Protective Association." There is no doubt that the membership list will shortly include every prominent jobbing firm in the country.

—It may not be generally known that on May 1 of this year, Michel Bloch ainé, of Paris, France, widely and favorably known in the diamond and precious stone trade, became special partner with a contribution of 500,000 francs in a limited co-partnership with Henry Dreyfus, under the style of Henry Dreyfus & Co. Mr. Dreyfus in his recent European trip, made extensive purchases, and the firm now has in stock, well worthy the attention of dealers, a full and beautiful line of diamonds and fine colored stones, such as rubies, emeralds, sapphires, etc.

—C. C. Morrison, who has been connected with the jewelry trade book department of R. G. Dun & Co. since its foundation, and who has lately had charge of that department and has just finished the August edition of the trade book, on July 25 left New York for Providence to enter the company's office in that city. From his long experience with the jewelry trade, we judge Mr. Morrison fully capable of looking after the interests of that trade in his new city. The new book, now ready for delivery, contains over 100,000 names of tradesmen throughout the United States and Canada, together with bank lists and State collection and assignment laws.

—The new pin-tongue catch recently patented and placed upon the market by Henry E. Oppenheimer & Co., 47 Maiden Lane, New York, has met with much favor among the trade, as being a device that thoroughly secures the lace pin from theft or loss, and protects the material in which the pin is fastened from tearing. These catches are used largely by the firm, but manufacturers can be supplied with them finished and ready to be soldered on their own lace pins. The reader should send for an illustrated circular. The firm's factory is now being run twelve hours daily, and large lines of fine diamond mountings and finished goods are being completed for the fall trade.

—In the beginning of last month, at Lucerne, twenty-five fraternal gentlemen, with their families, all Swiss-Americans, the majority of whom for business purposes make annual trips to Europe, agreed to come together while on the Continent, and celebrate royally, the anniversary of the signing of the Declaration of Independence of their adopted country. They met on July 12, at Luzerne, Switzerland, one gentleman coming from Spain and another from London, for the sole purpose of celebrating. Among them were J. Eugene Robert, Jules Racine, and Leon Gallet, of Julien Gallet & Co. For three days the merry party remained inseparable and jollity reigned supreme. The festivities included dinners, excursions to Mt. Pilatus and other places, and a variety of recreations to excite good humor.

—S. F. Myers, as one of the committee composed of himself and August Oppenheimer, appointed by the New York Jewelers' Board of Trade, to raise funds for the aid of the sufferers of the recent Johnstown calamity, will shortly stop over at Johnstown, while on his way west, and dispose of the balance of the sum raised.

—Albert Lorsch, of Albert Lorsch & Co., 37 Maiden Lane, N. Y., arrived from his annual European trip, on July 29. Mr. Lorsch, during his sojourn on the continent made extensive purchases for the coming season, and the firm is now displaying full lines of new goods. Alfred Krower will leave for the other side in the latter part of the month.

—The Justice Jobbing Co., has been incorporated with a capital stock of \$50,000, and will shortly commence business at 182 State st., Chicago, as general jobbers of American cases and movements. The officers of the new company are: H. M. Justice, president; G. N. Fitts, vice-president; M. R. Hart, secretary and treasurer; and John Bresin, general manager.

—A. J. Hedges & Co., manufacturers of rich diamond jewelry, 6 Maiden Lane, have prepared for the fall trade a large line of lace pins, scarf pins, brooches and pendants, hairpins, locket, Queen chains, etc., etc., all made in high karat gold. Their variegated gold work has become a staple with the fine trade, and their enamel work is scarcely excelled by any at home or abroad. A very pleasing pattern of a brooch will be found in their advertisement, to be followed by others during the fall.

—Fowler's English Crape Stone has become a staple with the jewelry trade. No more appropriate article for mourning wear has ever been devised, its corrugated crape-like surface harmonizing perfectly with the fashionably mourning costumes of the day. So popular has it become that the market is being flooded with imitation goods gotten up in cheap shoddy fashion and resembling the true article only in superficial appearance. The jeweler can protect himself against deception by remembering that Fowler's English Crape Stone jewelry is carded on crape bordered cards with the words "Fowler's English Crape Stone," embossed plainly on each card. None are genuine without this stamp and carding. Buyers of mourning jewelry should remember this fact if they want reliable goods of style and reputation.

—As pretty and simple a little advertising conceit as the writer has seen is that being issued by Irving L. Russell, importer of diamonds and other precious stones and dealer in diamond mountings, Corbin Building, New York. It consists of six diamond-shaped leaves, held together by a bow of silk. "Diamonds and other precious stones" in fanastically designed letters ornaments the first leaf; name an address, the second; on the third and fourth leaves are specified the various precious stones carried in stock—diamonds (single stones, match pairs, *mèlè*, *melange*, and fancy colored diamonds), rubies, pearls, opals, sapphires, turquoises (Ceylon and Burmese), emeralds, cat's eyes and chrysoberyls; on the fifth a statement of his diamond jewelry, brooches, pendants, rings, earrings, scarf pins, etc; and on the sixth, a pretty poetic stanza on the diamond.

—On the 1st of the current month the four representatives of Stern & Stern, 13 Maiden Lane, New York, started out on their fall trips to their several territories, carrying with them samples of the most extensive and attractive stock of diamonds, watches and jewelry that this well-known house have ever displayed. Among the jewelry are new, unique, and beautiful designs, exclusively their own, and unobtainable elsewhere. The writer saw some of them and was veritably astonished at the excellence and lowness of prices. The firm have prepared these extensive and beautiful lines, with the anticipation of a good fall trade, from the west as well as the east, and from the north as well as the south. We are sure that jewelers visiting the city would find it to their interest to spend a short time in the handsome offices of this firm to examine their fine stock before placing orders elsewhere.

—"Plain Truths about Diamond Cutting," is one of the most interesting pamphlets that have ever been issued to the trade. Though primarily an advertisement for its publishers, D. De Sola Mendes & Co., diamond cutters, 49 Maiden Lane New York, it partakes largely of the nature of an essay, the matter being written in strong and simple style. Within its sixteen pages solid facts relative to diamonds and diamond cutting abound in profusion. That lowness of cost is not synonymous with cheapness, as far as diamond cutting is concerned at least, is fully demonstrated; that practical and professional knowledge of the art is essential to the successful running of a diamond-cutting establishment, is also made fully clear. The work embraces a series of excellent rules to be followed by dealers and other persons desirous of having gems recut. Every dealer should have one of these little pamphlets in his office.

—H. E. Beguelin, of Cross and Beguelin, 21 Maiden Lane, N. Y., is due from Europe, August 4; he has been recuperating his health for three months, and it is said, he returns home greatly improved. The firm reports that last month's business far exceeded that of several preceding Julys, the increase not applying to any special lines, but effecting every line,—watches diamonds jewelry, materials and tools. A. F. Cross will soon leave the city for his cottage at Schroon Lake in the Adirondacks, New York, where he will sojourn until October 1.

—A representative of THE CIRCULAR visited last month the showroom of S. Klaber & Co., 47 West 42d st., New York, and inspected an assortment of Mexican onyx pedestals, tables, lamps and clock frames, which for universal excellence is unsurpassed by any other manufacturers in the country. In pedestals alone the firm manufacture fully 150 designs, and have over 40 designs regularly in stock. To attempt to describe the individual pieces and enumerate their many points of excellence would lead us too far. Suffice to say that this firm, having the choice of the richest variegated Mexican onyx and employing nothing but the purest of metals in the mountings, attain their aim—to make a superior line of art goods, particularly adapted to the finest class of the jewelry trade. The goods must be seen to be appreciated, and this dealers should do. The salesroom is very centrally located, being near the Grand Central Depot and the station of the 6th ave. Elevated Road.

—Wood & Hughes, the widely-known silversmiths, 16 John st., New York, are at present running largely into chased work, in tea services, toilet sets, large table and small ware. The representative of THE CIRCULAR was shown some specimens of this work,—a large tureen, teas, brushes, mirrors, nail brushes, combs, toilet bottles, horse hair whisk brooms, etc.—the surfaces, handles or backs representing one net work of leaves and flowers, daisies, roses, etc., faithfully and accurately executed and charming in effect. Some pieces of superlative beauty shown were a pitcher, the surface combining etched, chased and satin-finished work, and a toilet set, combining acid-finished, satin-finished and etched work. As to their satin-finish it is safe to assert that Wood & Hughes have no peer. Some beautifully designed match boxes have just been placed upon the market; besides these, are carried fully forty different designs with etched, chased and stamped surfaces, and some with oxidized effects.

—The Chicago Horological Institute, of Chicago, Ills., now one of the foremost institutions of its class in the world, has issued a little pamphlet that every young man desirous of learning the trade of watchmaking in a short time, and at a very moderate expense, should read. The aim of this institution is to give such young men and to the members of the trade, a thoroughly practical, theoretical and technical education in watch making and repairing, in a fractional portion of the time otherwise devoted to their acquirement. That the institute accomplishes this desired end is evidenced by the statements set forth in its interesting advertisement printed elsewhere in this issue. In this practical age, the most valuable trade instruction must resemble that which its recipients will be expected to accomplish when they depend upon their trade for a livelihood. Such instruction combines theory with practice, and the ambitious young man will learn both. Watchmakers who have received but the practical knowledge of their art, and appreciate the lack of the other ingredient, by a few months' attendance at the Chicago Horological Institute, will receive as much theoretical knowledge as it would take years of solitary study to acquire.

Among the Watch and Clock Factories.

—The Aurora Watch Factory, at Aurora, Ill., has now a full force working ten hours daily.

—It is reported that the wild town of York, Neb., is endeavoring to establish a watch factory within its limits.

—The Ansonia Clock Co. are perfectly satisfied with their new Chicago store at 103 Wabash avenue. It is elegantly fitted and commodious, and its location is proving advantageous to business.

—The Columbus Watch Co. are contemplating a removal of their works from Columbus, O., and are awaiting inducements from other cities. The company desire to enlarge their factory, and to do this it will be required to double the present capital stock of \$200,000. They propose to employ from 600 to 1,000 people.

—According to the report to the State Department of Minister Hubbard, there were imported into Japan in 1888, watches valued at 704,000 silver yen (silver yen equals about 74 cents) as against 368,000 during 1887; of the former amount \$122,000 worth of watches represented those of American manufacture, a gain of \$107,000 over the previous year.

—The Metropolitan Watch Co. has been incorporated in New York by W. F. Atkins, Warren Scarborough, D. S. Baker, Godfrey Landmann and J. E. Mitchell. The capital stock is \$200,000, and the company will manufacture watches and jewelry.

—The Illinois Watch Company have now taken up a prominent position in England. It is claimed for the Illinois watches that they are specially fitted to suit the ideas of the English watchmakers. This makes the fourth American company represented in England, and it is said that four more contemplate an immediate settlement in that country. It is clear that whatever complaints the English may have in the future, want of competition will not be among them.

—The Manhattan Watch Co. have just placed upon the market the first lot of their new filled case watches, with improved movements. The new features in these movements consist of the mainspring being so arranged as to allow of its being taken out without taking the movement to pieces, and of the capability of letting the mainspring down without separating the movement from the case. These are points of advantage of which dealers should take cognizance. The company has on hand more orders than can readily be filled.

—An English contemporary having read the paragraph in the July CIRCULAR to the effect that the Great Northern Railway Co., of England, recently ordered twenty non-magnetic watches of the American Watch Co., raises a wail and desires to know what the English manufacturers are about, and asks if there are no home productions to be had. Perhaps if our "esteemed, etc.," fully appreciated the essence of American enterprise, and were thoroughly informed on the merits of the non-magnetic watch of the American Watch Co. he would be hardly so nervous.

—The Rockford watch factory is running full time on their new model movement trying to catch up with the orders on hand. J. P. Drake, their genial New York agent, informs us that the company are turning out 200 movements daily, and will soon enlarge their plant to enable it to turn out between 250 and 300 movements daily. Mr. Drake came to New York a perfect stranger to the trade, but in a few short months has made scores of friends. The Rockford Co. have now disposed of their old model movements, and will hereafter carry only the one model, which will be made in 6, 16 and 18 sizes. They claim that their new pendant set will give the others a hard rub.

—The largest chiming clock in America is now being placed in the belfry of the Court House at St. Paul, Minn. The prodigious clock, the product of the Seth Thomas Clock Co., arrived in that city on July 9, packed in 21 large boxes, weighing in all 11,360 pounds, and filling a car. A corps of expert mechanics at once set to work to install it in the tower. The clock will tell the hours and the quarters; will sound the Westminster and other chimes, and will regulate the huge bells in the Belfry that have been silent for two months. The dial is ten feet in diameter and will illuminate itself at a set hour. The mechanism is such that it will turn the lights on and off at a desired second, and it can be so regulated that it will not ring at certain periods, this latter arrangement being provided in the exigency should the ringing of the bells be found unpleasant during the later hours of the night. For the first quarter-hour four taps will be given, for the second quarter eight taps, and for the three-quarters twelve taps.

—The August *Waterbury* will contain for its central illustration, a two page representation of the Egyptian god, Horemku, commonly known as the Sphinx, with several laborers at its base, unearthing Waterbury watches. The execution of the idea is true to the original, and shows the Sphinx to be quite a different thing to our conventional conception of a horse with a woman's head. Though we have as yet not seen the complete copy of this month's issue, we presume that it will be up to the high standard established by the last half-a-dozen numbers. Of recent years a few of the more progressive companies of the country, believing in the efficacy of liberal though judicious advertising, have adopted a mode of bringing their business more prominently before the public mind, that in itself is most praiseworthy, and that must produce the desired results. This consists of the issuing to their trade, of a weekly or monthly periodical of humorous characteristics. Without doubt, the best of these, is this *Waterbury* issued by the Waterbury Watch Co. To those who may not know it (they are few indeed) we will inform them that it is of the size of *Life*. Pictorially it is almost the equal of that humorous pamphlet, *Judge or Puck*; the artist being a gentleman who does work for those journals; and its humorous paragraphs are pointed and American. The editor of the *Waterbury* is undoubtedly a journalist of experience, for he attains success in journalism's perhaps most difficult field.

—The Non-Magnetic Watch Co. will have a large exhibit of Paillard non-magnetic watches at the Convention of the National Electric Light Association, to be held at Niagara Falls, Aug. 6, 7 and 8.

—By reading the advertisement of the E. Howard Watch & Clock Co., a fair knowledge of the comparative appreciation of the different makes of American watches by the Inspectors of the various railroads will be gleaned.

—During the past month a goodly number of the western and Canadian jobbers and buyers who visited New York, made their headquarters in the handsome offices of the Hampden Watch Co. and Dueber Watch Case Mfg. Co., 178 Broadway.

—The Non-Magnetic Watch Co. announce on page 28, a reduction in prices of Paillard Non-magnetic Watches, and offer to rebate the stocks of all dealers having on hand any of the grades reduced. This policy of the Non-Magnetic Watch Co. insures retailers against loss by reduction in prices of their watches, and is one that is bound to be appreciated. The company have just received a large invoice of complicated watches, including minute repeaters, chronographs, split-seconds, perpetual calendars, and combinations of the same. These watches can be had through any regular jobber.

—A. C. Smith, having, after three months' absence, accepted the General Selling Agency for the entire product of the Non-Magnetic Watch Company of America, this fact combined with a largely increased product, plenty of capital and the association of men of large business experience, will start the Paillard Non-Magnetic Watch out on a boom such as it has never had during its phenomenally successful career. Mr. Smith is laying his plans for the fall campaign which, under his supervision, will, no doubt, be a vigorous one, and characterized by his usual push and energy. If the Paillard watch is not a great success it will be no fault of A. C.'s.

—On July 20 the first lot of the new nickel six size movements of the Illinois Watch Co. was received at the company's New York office and was immediately gobbled up, and large orders for them are now awaiting to be filled. The movement is known as No. 149, and is the only seven jeweled six size movement now offered to the jobbing trade. The company will, during August, make delivery of their new 14 size, open face, pendant setting movements with seven jewels, known as No. 120. These movements will be furnished either uncased or with silver and silveroid cases. Orders for these grades will be filled in rotation, so the sooner orders are placed the sooner will they be filled.

—One of the busy places in the New York jewelry district is the office of the New York Standard Watch Co., in the Corbin Building, 13 John street, ground floor. The methods adopted by the general selling agent, Frank G. Miller, to create a demand for the "N. Y. Standard" movement, have produced excellent results, and orders of good size are of frequent occurrence. Since the new partitions have been put up the office has had a very attractive appearance, and now perhaps no more handsomely fitted office is to be found among the many in that new watch and jewelry building, the "Corbin." All who have business to transact with this company will always receive a pleasant greeting.

—The prodigious clock just installed in the tower of the new depot in Jersey City of the New Jersey Central Railroad, is the product of the E. Howard Watch and Clock Co.'s factory. This clock has the largest glass dial of any clock in the country, it being 14 feet in diameter. The clock faces the Hudson River, and is so enormous that the time can easily be discerned from the docks on the New York shore. Thirty-two electric lights illumine the dial at night. A double dialed clock, six feet in diameter, has been placed by the same company in the waiting room of the depot. One dial faces the interior of the room, while the other is seen from the incoming trains. One mechanism operates the two sets of hands.

—The United States Watch Co., of Waltham, Mass., intend to enlarge their factory in the early spring, by the erection of a central building, fifty feet front and four stories high, and the addition of a wing one hundred feet long, of three stories and a basement. The product of the present factory is about one hundred and fifty movements per day, and the addition will give a capacity for at least three hundred per day. The goods of this company are so well known that praise is unnecessary, the universal testimony of the trade being that for accuracy and finish they are worthy of all commendation. The new six size that will be ready for the fall trade is among the prettiest ladies' watches made, and the factory is kept running to its fullest capacity to meet orders already ahead and those that promise to come in this fall. So great is the demand for the United States movements that the company have been obliged to deny their operatives a vacation this year—a thing somewhat remarkable among watch factories.

—The Waterbury Clock Co.'s catalogue will be ready for issue early this month.

—The Trenton Watch Co. intended to take their regular six weeks' summer vacation, but the demand for their new watches is so great that they have reduced the length of the vacation to two weeks, from July 27th to Aug. 13th.

—The New Haven Clock Co. are fully prepared for the fall trade with a large number of new lines. At their New York office, 29 Murray street, may be seen a full line of eight day and one day clocks in newly designed black walnut frames, a large line of very handsome bronze figure clocks in electro-bronze and silver platings (these figure clocks consist of a fancifully-designed clock with a bust or figure at its side, both on one base), an entirely new line of eight day clocks, with silver dials and cabinet frames made in walnut and antique oak, with brass ornamentations, several new designs in black "Irons," some very elegant hanging clocks, newly-designed, a fine new line of French marble clocks fitted with the 15 day New Haven movement, some new and beautiful Mexican onyx clocks, and so on almost indefinitely. A peculiar novelty, new for the coming season, is a cheap alarm clock that rings every three minutes for an hour after the set time. The alarm can be stopped at will. A person who will not wake after twenty several rings of an alarm clock, would sleep as well on a picket fence as on the softest of live feather beds.

—The Otay (Cal.) Watch Factory is now completed. The general office, presided over by J. H. Guion, general manager, presents the most elaborate appearance of any office used in connection with manufacturing that we have ever seen. It is made of red brick, finely lined between each brick. The Cottier system of ventilation is in use. It is finished inside and out with pieced gnarled red wood, polished in various colors, as only red wood can be. The office is divided into two divisions, and a hall passes through the entire length of the building. The partitions are also made of variegated red wood, polished like glass, which reaches about four feet from the floor, and is carried up about four feet more, with gilded screens with half round openings. The other side of the hall is finely carpeted, with gilded screens reaching about four feet from the floor. This is intended for the general manager and for reception rooms. The transoms and upper sash of windows are frosted pea green and elegantly decorated. The lower sash is supplied with pea green damask curtains. The furniture is solid black walnut, and, in connection with the above surroundings, presents a fine appearance. The main building is separate from the office, is three stories high, built of red brick, the window sills being of white stone, with frames and casings of Oregon pine and California red wood in variegated colors. The windows are large, the upper sashes of which are frosted pea green, with regular designs, making a pleasant appearance, pleasing to the eye. The floors are double, and of narrow, hard wood. The engine and boiler room is finished in solid Portland cement, sides and floor, and are as smooth as glass. The massive Westinghouse engines, boilers, pumps, heaters, etc., reminds one of the engine room of an ocean steamer. The shaftings are all up and pulleys in position. The machine shop lathes are being placed in position, and the machinery, now being put up, is of the finest and most improved kind. The office of the main building is made of variegated red wood and gilded wire, and is quite novel in construction. It is situated on the first floor, and is presided over by P. H. Wheeler, superintendent. Palm trees, flowers, etc., are being set out in front of the factory, and will present an appearance never seen around a watch factory before. Otay feels proud of such a magnificent institution. It is a credit to Southern California.—*Otay Press.*

—The following, descriptive of the new building to be erected by the Elgin Watch Co., for the physical and intellectual welfare of its employees is gleaned from the *Elgin Courier*: "We are enabled to present to-day a fine engraving of the new building to be erected this season by the watch company for the physical welfare of its employees. We do not know of another manufacturing concern which has provided for such use anything so elaborate or expensive. It is the experience in all sedentary occupations that pulmonary diseases secure a foothold in numerous instances because of a lack of proper exercise. To better the general health the company is now substituting throughout its departments electric for gas lights. There is no economy in maintaining the new system, the reverse rather being true, and the substitution required an outlay of over \$50,000, but it will save life. In the winter the sudden increase in the temperature when the gas was lighted, and the rapid consumption of whatever pure air remained, have been a source of much illness. A better system of ventilation is also to be undertaken. The amusement building will be a material aid in these health reforms. From

the engraving it will be at once seen that the new building will be a handsome one, of a much more elaborate design than the National house, which it will join on the east, facing National street of course. It will be a large four story building 45 feet front with a depth of 104 feet, of white brick with terra cotta trimmings, the first story of large cut stone, and have a slate roof and tower on the southeast corner. The first floor is to be a model home for the company's band; the second floor will contain the amusement hall; on the third floor will be the gymnasium, forty-one by seventy-one feet;

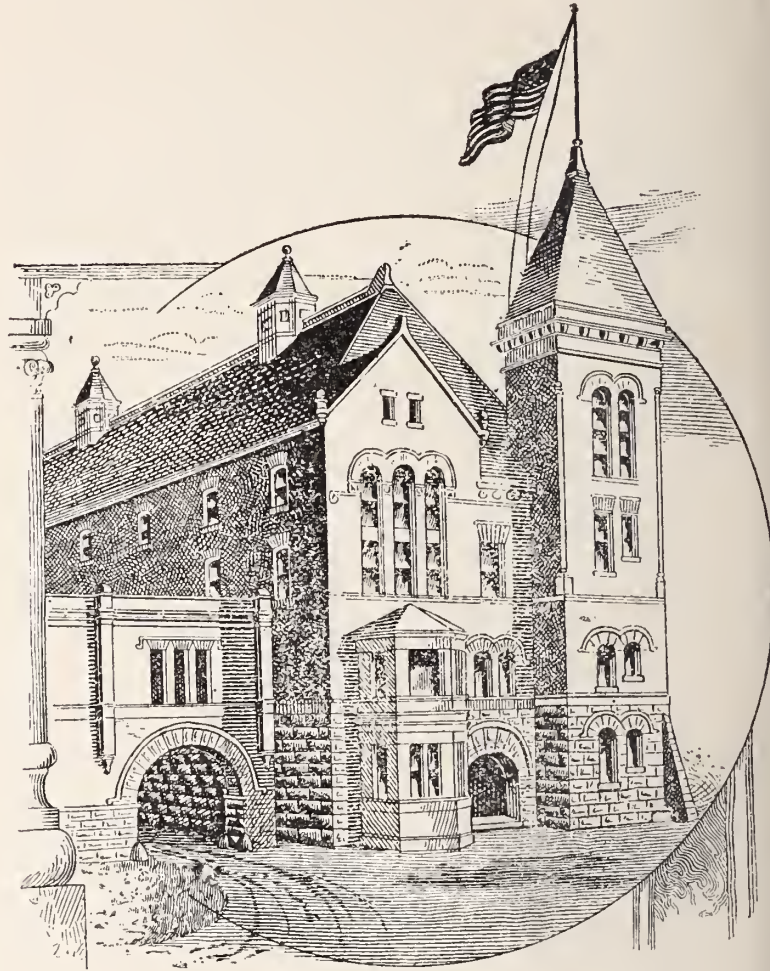

THE ELGIN CO.'S PROPOSED GYMNASIUM BUILDING.

and above, in the rear of what in front will be a fourth floor, will be a running gallery, the circumference of the gymnasium. The gymnasium will have every modern improvement possible, and will be open to the public with but a nominal charge.

The building will be begun at once and completed this summer. It will cost in excess of \$30,000. The finish inside will be natural woods, and both outside and inside it will be a great credit to the company and to the city as well."

—E. A. Thrall, 3 Maiden Lane, New York, jobber in all grades of American watches, and importer of precious stones, is notifying the trade that he will demagnetize any watch sent him and return it on the same day as received, free of all expense except expressage. His demagnetizing process, which is part his own invention, is claimed to effect a perfect cure. Mr. Thrall cited to the writer several cases where watches sent to others with ineffectual results, had finally been submitted to him and perfectly demagnetized.

—Dealers visiting New York should not fail to call upon J. Eugene Robert & Co., 30 Maiden Lane, where they can examine the most complete line of Swiss watches, with either plain or complicated movements, that can be found in America. In this stock of watches, which includes large assortments of the famous Agassiz and Longines, Louis Audemars and Jules Monard, of which they are sole agents, and chronographs with split seconds, minute repeaters, etc., will be found numerous novelties as the firm keeps pace with the characteristic of the present times, which is a constant call for new things.

TABLE OF CONTENTS.

American Art.....	29	Cylinder Plugging Tool.....	74	Kent & Stanley.....	37	New Watch and Clock Key.....	54
Around Boston.....	82	Fashions in Jewelry.....	57	Imperial Diamond, The.....	37	Paris Gossip.....	49
Attleboro, The.....	85	Art Glass and Keramics.....	61	Gossip of the Month.....	25	A Rare Collection of Jeweled Bonnets.....	49
Chicago Briefs.....	42	Foreign Gossip.....	73	In the South.....	46	Obituary—John J. Hyde.....	106
Chicago Horological Institute.....	89	Foreign Matters.....	41	Jewelers' Security Alliance.....	38	Plate with Aluminum, To.....	74
Cincinnati Letter.....	85	Glimpses of the Paris Exposition.....	30	Jewelers' and Tradesmen's Company, The.....	93	Providence Notes.....	86
Combination of Independent Full Second and Chronograph with Zero Setting.....	69	Gorham Mfg. Co.....	34	Lathes and Lathe Work.....	62	Quaker City, The.....	46
Communications.....	66	Meriden Britannia Co.....	30	Mechanical Ocular Defects.....	65	Recent Patents.....	53
Complete History of Watch and Clock Making in America—Watch Case Making.....	81	Standard Time Service and Seth Thomas Clocks.....	30	Motive Force in Watches, The.....	78	Trade Gossip.....	97
		Waterbury Pyramid.....	34	Neglected Problems—Measuring the Wheel and Pinion Depths.....	93	Among the Watch and Clock Companies.....	105
						Workshop Notes.....	77

INDEX TO ADVERTISERS.

Abray, Chas. Leo.....	79	Dueber Watch Case M'g. Co.....	19	Lorsch, Albert, & Co.....	Outside back cover	Sexton Bros. & Washburn.....	72
Aikin, Lambert & Co.....	103	Elliott, Geo. & Co.....	Inside back cover	Mahler, H.....	64	Sheafer, W. H., & Co.....	52
Alvin Mfg. Co.....	25	Essex Watch Case Co.....	44	Mathey Bros., Mathez & Co.....	10	Smith & Knapp.....	39
American Horological Institute.....	95	Evans, W. F. & Sons.....	80	McCall & Newman.....	63	Smith, Alfred H. & Co.....	27
American Waltham Watch Co.....	43	Falkenau, Oppenheimer & Co., Outside bk cov.	76	Meriden Britannia Co.....	48	Smith B. & W. B.....	Outside back cover
American Watch Tool Co.....	76	Fisher & Sons.....	76	Merritt, S. F.....	23	Smith, H. M. & Co.....	92
Anti-Magnetic Shield & Watch Case Co.....	23	Floyd, Pratt & Rounds.....	92	Middletown Plate Co.....	7	Special Notices.....	109
Arnstein Bros & Co.....	14	Foster & Bailey.....	63	Miller Bros. & Co.....	56	Spencer Optical M'g Co.....	9
Atkinson Bros.....	84, 91	Fox, M. & Co.....	87	Montgomery & Co.....	115	Stark, John.....	20
Aurora Watch Co.....	44	Fowler Bros.....	31	Moore & Horton.....	63	Sterling (The) Company.....	4
Bartholomew & Peckham.....	115	French, J. H.....	80	Muller's Sons, Nicholas.....	10	Stern & Stern.....	13
Bawo & Dotter.....	32	Friedlander, R. & L.....	15	Myers, S. F. & Co.....	68	Stockwell, E. R.....	68
Beguellin, Tell A.....	108	Froelich, H. & Co.....	14	N. Y. Watch Case Spring Co.....	109	Straus, L. & Sons.....	56
Bedichimer, I.....	95	Geneva Optical Co.....	21	Newman, Louis, Jr.....	115	Sussfeld, Lorsch & Co.....	87
Berlin Demagnetizer Co.....	8	Glaenger, Leon J.....	103	Nicholson File Co.....	79	Taintor & M. Alpine.....	52
Birch, John S., & Co.....	108	Gorham Mfg. Co.....	24	Nissen, Ludwig, & Co.....	60	Tannenbaum, L. & Co.....	60
Blancard & Co.....	75	Grant, J. W. & Co.....	20	Non-Magnetic Watch Co.....	36	Taylor & Bro.....	83, 87
Bookhout Bros.....	115	Haldimann, E. A.....	14	Noterman, Jos. & Co.....	14	Ternent, F.....	115
Bowden, J. B., & Co.....	40	Hamilton & Hamilton, Jr.....	104	Nye, Wm. F.....	92	Thrall, Edwin A.....	47
Braxmar, C. G.....	115	Hartford Silver Plate Co.....	21	Odenheimer & Zimmern.....	116	Thurnauer, G. M.....	22
Bradley & Hubbard Mfg Co.....	47	Haskell, H. C.....	104	Oppenheimer Bros. & Velth.....	68	Todd, Ed. & Co.....	Outside back cover
Brown, Thos. G. & Sons.....	88	Hausburg, E. O.....	115	Oppenheimer, Henry E. & Co.....	69, 64	Towle M'g Co.....	39
Bryant, M. B. & Co.....	79	Hearn & Braltsch.....	15	Oskamp, Nolting & Co.....	71	Trenton Watch Co.....	100
Buhler & Nanz.....	91	Hedges, A. J., & Co.....	60	Ostby & Barton.....	55	Troemner, Henry.....	115
Bynner, T. B.....	115	Hedges, Wm. S. & Co.....	59	Owen, G. & S., & Co.....	52	United States Watch Co.....	28
Byrd, C. L. & Co.....	16	Howard, S. P.....	Outside back cover	Pairpoint M'g Co.....	2	Van de Sande, Chas. & Co.....	22
Carter, Sloan & Co.....	51	Hyde's Sons, John E.....	76	Peterson & Royce.....	91	Valuable Instruction Books.....	Inside bk cover
Cattelle & Decker.....	91	Imhauser, E.....	115	Pforzheimer, Keller & Co.....	76	Wade, Davis & Co.....	72
Chalmers-Spence Co.....	80	Jackson, S. C.....	116	Pinnell, May & Co.....	22	Waltham School of Horology.....	84
Champerols & Co.....	75	Jacot & Son.....	71	Pinover, A. & Co.....	92	Wallace, R., Sons M'g Co.....	64
Cheever, J. G. & Co.....	87	Jacques, Charles.....	1	Plainville Stock Co.....	79	Washburn & Moen Mfg. Co.....	115
Chicago Horological Institute.....	47	Jeannot & Shlebler.....	67	Platt, Chas. S.....	Outside back cover	Washburne, E. G. & Co.....	14
Citroen, Vve. L. B., & Co.....	14	Kahn, L. & M. & Co.....	8	Prindle & Russell.....	75	Watchmaker, Jeweler and Silversmith.....	108
Clark, A. N.....	80	Keller, L. H. & Co.....	108	Randel, Baremore & Billings.....	96	Waterbury Clock Co.....	1
Colby, C. K.....	8	Kendrick & Davis.....	80	Riley, John A.....	72	Waterman & Lehmann.....	107
Conover, D. F. & Co.....	18	Kent & Stanley.....	20 & 55	Riley-Osborn Mfg. Co., The.....	2	Well, Maurice.....	14
Cooke, B. J's. Sons.....	75	Ketcham & McDougall.....	15	Robert, J. Eugene, & Co.....	67	Weich & Miller.....	76
Cox & Sedgwick Mfg. Co.....	23	Kirby, Mowry & Co.....	56	Rogers & Bro.....	11	Wheeler, Hayden W. & Co.....	40
Cottler, C. & Son.....	115	Klaber, S. & Co.....	15	Rogers & Hamilton Co., The.....	104	Whiting, F. M. & Co.....	12
Cottle, S. Co.....	99	Klingenberg, A.....	60	Rogers, Smith & Co.....	17	Wiggers & Froelich.....	Inside back cover
Crescent Watch Case Co.....	43	Koeh & Dreyfus.....	40	Russell, Chas. A. & Co.....	Inside back cover	Wilkinson, C. B.....	115
Cross & Beguellin.....	17	Kohlbusch, Charles.....	115	Russell, Irving L.....	84	Woglom, Gilbert T.....	63
Crouch & Fitzgerald.....	Outside back cover	Krementz & Co.....	107	Sartorius, A. & Co.....	115	Wood & Hughes.....	52
Day & Clark.....	16	Lapp & Flershem.....	6	Sauter, L. & Co.....	52	Wood, Chas. F.....	75
Didishelm, Hipp.....	87	Laurencot, J. B.....	116	Schleicher, Schumm & Co.....	63	Wood, J. R., & Son.....	115
Dorflinger, Chas. & Sons.....	28	Lawson & Van Winkle.....	8	Scott, J. T. & Co.....	39	Zineman, M. & Bro.....	87
Dreyfus, Henry, & Co.....	3	Lelong, L. & Bro.....	Outside back cover	Seth Thomas Clock Co.,.....	Inside front cover		

INTERIOR VIEW OF THE
BEE HIVE OF THE JEWELRY TRADE.

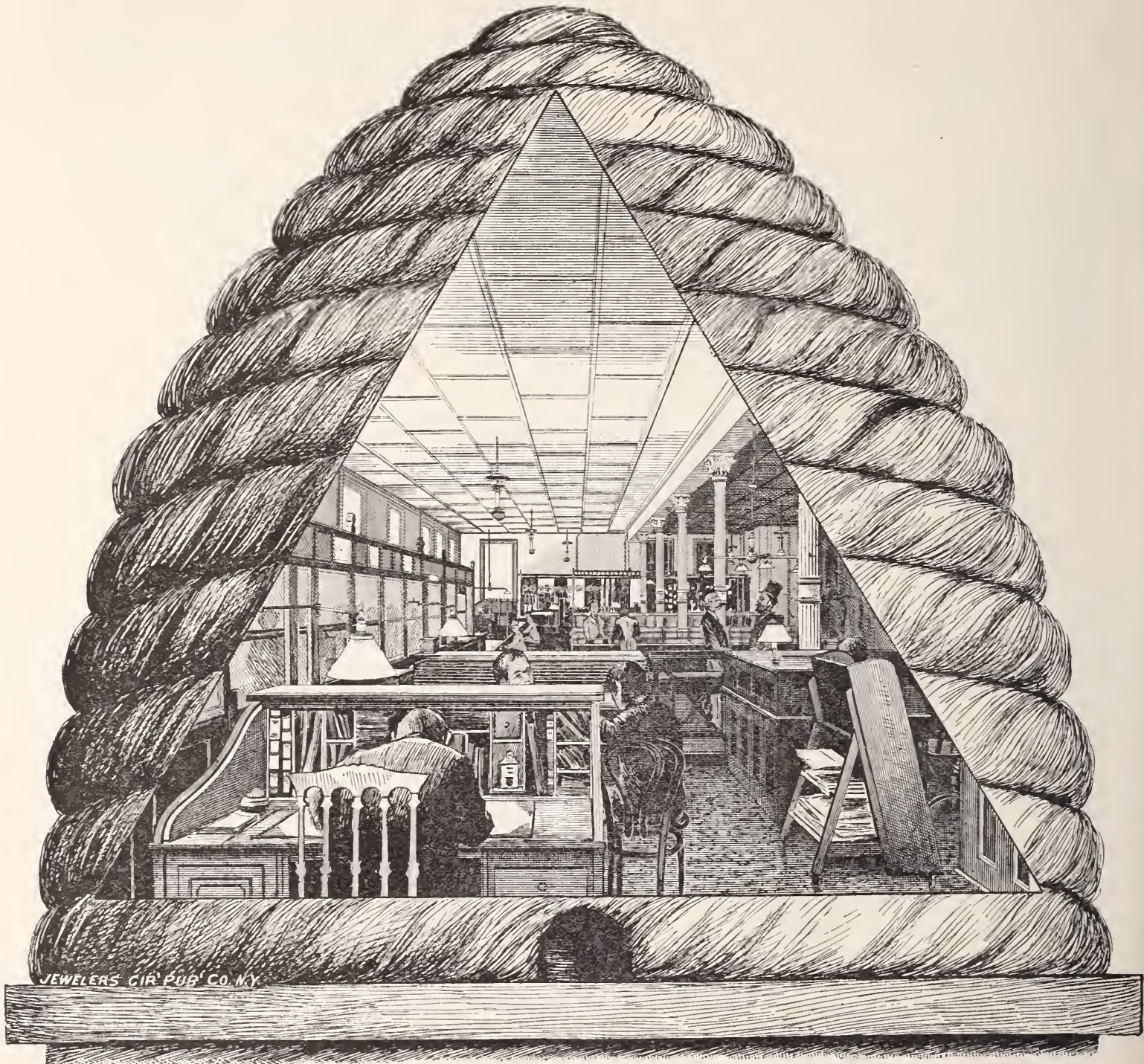

OFFICE AND SALESROOM OF
LAPP & FLERSHEM,

92, 94, 96 & 98 STATE STREET,

CHICAGO, ILL.

WHOLESALE DEALERS IN EVERYTHING NEEDED BY JEWELERS.

PUBLISHERS OF

"THE BUSIEST HOUSE IN AMERICA" Catalogue, without our name and address.



VOLUME XX.

NEW YORK, SEPTEMBER, 1889.

No. 8.

THE JEWELERS' CIRCULAR

AND

HOROLOGICAL REVIEW.

OFFICIAL REPRESENTATIVE OF THE JEWELERS' LEAGUE, THE NEW YORK JEWELERS' BOARD OF TRADE, AND THE JEWELERS' SECURITY ALLIANCE.

It is also the Recognized Exponent of Trade Interests.

A MONTHLY JOURNAL DEVOTED TO THE INTERESTS OF WATCHMAKERS, JEWELERS, SILVERSMITHS, ELECTRO-PLATE MANUFACTURERS, AND THOSE ENGAGED IN THE KINDRED BRANCHES OF ART INDUSTRY.

SUBSCRIPTION.—To all parts of the United States and Canada, \$2.00 per Annum, Postage Paid. To all Foreign Countries, \$3.00 per Annum, Prepaid.

All communications should be addressed to

THE JEWELERS' CIRCULAR PUBLISHING CO.,
189 BROADWAY, NEW YORK.

Advertising rates made known on application.



A full Index to Advertisements and Table of Contents will be found on Page 5 of this issue.

THE rapid advance we have been making in educational matters in the past ten years is well shown by the special technological schools that have been springing up in various sections of the country. We now have schools where a man may perfect himself in almost any mechanical branch and put the fine polish of the highest scientific knowledge on his education. In all the trades the prentice system is being superseded by the school system. But the watch making trade for some reason or other has been slow in adopting the new order of things. It was only quite recently that a few bold spirits saw the needs of the hour and set about endeavoring to give us what we had long been suffering for—good horological schools. Time was, and not so very long ago either, when a boy who wished to learn watchmaking could not do better than apprentice himself to some watchmaker of local reputation, and who, generally speaking, had little grasp of mechanical principles, and who, judged by present standards, would scarcely be called a competent workman. Here he would serve his time, picking up the crumbs of information that fell sparingly from his master's table (for a man may have a good practical knowledge of a trade and yet be utterly unable to impart that knowledge). Under these circumstances the apprentice seldom

excelled his master, his ideas being necessarily confined to that individual's limited experience. Thanks to the "increasing purpose" of the age, a better way is open to the youth of to-day. It must be evident to the most superficial reasoner that the advantages offered by a good horological school are far greater than any the old-fashioned prentice system could possibly give. In the first place, the man who makes a business of teaching any art or trade must become better fitted to impart instruction in that art or trade than a mere practitioner of it. Experience will give him a knowledge of human nature and a skill in treating his subject that can be obtained in no other way. This alone is a distinct gain. Another advantage is that the equipment of a school, including tools, models, etc., is quite sure to be more complete than any retail store or repair shop can boast of. The close proximity of urban schools to libraries, museums, watch factories and other institutions of educational value should not be overlooked. These advantages which we have briefly touched upon are positive and apparent to all. There are still others that might be mentioned, such, for example as the benefits a young man derives from association with congenial companions of good abilities, for his associates in the class room will be of a higher average grade of intelligence than can be found in any one neighborhood. Those who attend these special technical schools are among the brightest and most ambitious youth in the land, eager to embrace every opportunity for improvement that is within their reach. This last, which may be termed the influence of association, is acknowledged to be one of the chief benefits of a college education. Hence it is that THE CIRCULAR welcomes the present movement for higher horological education, feeling assured that the result will be a very decided elevation of standards in the watch making trade, and the correction of many of the evils which our esteemed correspondent "J. W. H." points out in our "Communications" this month. Possibly as he intimates, some of these institutions, in their inexperience and flushed with early enthusiasm, may have tried to create the impression that they had a wonderfully short cut to proficiency in watch making. But if there are any such they must speedily discover the folly of attempting any hotbed cultivation of experts and settle down to honest, earnest work, which is the only sure foundation for them to build on. THE CIRCULAR will watch the progress of these schools with the most friendly interest, confident that the time is ripe and that those manifesting enterprise and thoroughness worthy of the cause will achieve success in astonishingly short time. Chicago has shown us what can be done in this direction.

* * * * *

Read "Art in America," by John Ward Stimson, page 29.

* * * * *

FLOATING exhibitions are becoming a favorite mode of developing export trade in the prominent commercial nations of Europe. The steamship, *Condé de Vilano*, having on board a representative collection of specimens of Spanish natural and industrial

productions, has sailed from Spain on her exhibition trip to the different South American countries. A considerable amount of money and a great deal of care and time have been expended on this enterprise, which is under government patronage. At the same time the German floating exhibition, mentioned in a recent issue of THE CIRCULAR, for the equipment and manning of which 5,000,000 marks have been raised, is rapidly approaching completion. A steamer of large dimensions (564 feet long, 66 feet beam and 46 feet depth), built specially for this purpose, with four independent engines and four propellers, will be elaborately fitted up with electric lights, etc., and arranged with show rooms and every facility for the display of German manufactures. She is to make a trip of two years to the chief markets throughout the world, in which it is supposed that a trade in German goods can be established, and in a number of instances the exhibitors will accompany their goods for the purpose of explaining their merits and pushing their sale. She is expected to be ready to sail from Antwerp early in the spring of 1890. In the arts of encouraging export trade it must be admitted that these foreign nations are far ahead of us. The idea of sending out such floating bazaars has never occurred to us, notwithstanding our boasted push and progressive ideas. And yet this seems to be the most ingenious device for booming export trade that has ever come under our observation. How long are we going to limit our enterprise to the fierce and sometimes ruinous competition of the home market?

* * * * *

"Do we make watchmakers too fast?" page 66. Send us your views.

* * * * *

THE London *Horological Journal* states that the fashion of giving bracelets as engagement tokens has been introduced in England. Makers of wedding rings need not be alarmed at this news, however, for the time-honored custom of preferring the circlet for the engagement finger, hallowed as it is by the superstitions of ages, is too deeply rooted to be easily superseded. While the fair sex will doubtless hold to the sacred traditions that cluster around the wedding ring they will scarcely object if the symbolism is completed by a band for the wrist. Bracelet manufacturers on this side of the water might look into this matter with a view to devising styles appropriate for the engagement token.

* * * * *

"A Rare Collection of Jeweled Bonnets;" illustrated in our Paris correspondence.

* * * * *

SALESMEN in the jewelry line have been a good deal troubled of late by the refusal of railroad companies to check their sample trunks, causing them annoyance and frequently delaying their journey. The recent decision of Judge Gresham in the case of Perry Bros., of Chicago, against the Wabash Railroad, will probably have the effect of making the railroad companies still more guarded in taking the baggage of jewelry salesmen. There is no possible way in which they can be compelled to take such baggage against their will, and it would seem on reasonable grounds that the proper manner of transportation is by express. Certainly the receiver of valuable merchandise should know approximately its value and is entitled to the option of refusing it. Some seem to suppose, however, that this principle does not apply to railroad companies as they are common carriers, and as such are supposed to be required to transport all passengers and freight that may be offered to them at uniform rates. This is obviously subject to very important limitations, for even railroads cannot perform impossibilities. Things might be offered to them which they could not possibly transport, or could transport only at the risk of life or to the detriment of their rolling stock. The railroad company has rights and cannot be expected to take

unreasonable risks or jeopardize the rights of its patrons. If experience has shown them that they cannot afford to be responsible for valuable trunks, while there are express companies organized for just such business, they are simply exercising ordinary business prudence in refusing them. In the case of Perry Bros. vs. the Wabash Railroad, the trunk was evidently accepted by the station agent knowingly, and consequently the company was responsible for the damage caused by the wreck which followed. If there had been any deception the case would have been decided very differently.

* * * * *

Magnificent Views of the displays of the Prominent American firms at the Paris Exposition. page 30.

* * * * *

THE New York Institute for Artist-Artisans, 140 West 23d street John Ward Stimson, superintendent, opens for the new term on October 1, with increased facilities and every indication of a prosperous year. The annual report of the superintendent is so remarkable a document that we would advise all interested in art or educational work to send to Mr. Stimson for a copy. To any of our young readers who may wish to fit themselves for designing in any of the decorative trades we would say, investigate this school by all means. It offers advantages that cannot be obtained elsewhere in this country. For a few gleamings from this remarkable report we would refer our readers to another page of this number.

* * * * *

Dr. Bucklin's valuable series on "Mechanical Ocular Defects, resumed in this issue.

* * * * *

THE Secretary of the Treasury's report on exports and imports for the month ending June 30, 1889, contains the following items of interest to the jewelry trade: "Imports of rough and glazier's diamonds, 1888, \$64,403; 1889, \$27,245. Imports of clocks and clock materials, 1888, \$19,727; 1889, \$19,495. Imports of watches and materials, 1888, \$130,382; 1889, \$117,153. Imports of jewelry and manufactures of gold and silver, 1888, \$88,726; 1889, \$67,775. Imports of precious and imitation stones, 1888, \$1,017,030; 1889, \$1,095,305. Exports of clocks and clock materials, 1888, \$71,158; 1889, \$113,471. Exports of watches and materials, 1888, \$67,174; 1889, \$9,984. Exports of jewelry and manufactures of gold and silver, 1888, \$33,978; 1889, \$115,713. Exports of plated ware, 1888, \$42,954; 1889, \$30,752. There is but little worthy of comment in this showing, except the very marked decrease in the exports of watches and an almost equally marked increase in the exports of jewelry. During the twelve months ending June 30, 1888, the exports of jewelry amounted to \$439,417, while during the twelve months ending June 30, 1889, the total was \$916,264. The increase for the month of June was still greater, as will be seen by a reference to the foregoing table. It is gratifying to THE CIRCULAR to see that a policy of foreign trade it has consistently advocated is now being adopted by many of the eastern manufacturers to their manifest gain.

* * * * *

Don't forget to keep posted on "Art Glass and Keramics," page 61.

* * * * *

THE appointment by Mayor Grant of Messrs. D. F. Appleton and Chas. L. Tiffany to represent the watch and jewelry trade in the counsels of two of the Committees of the World's Fair of 1892, must give satisfaction to all. The trade can safely entrust its interest to their care. The committees are already grappling with the problems involved and a report may soon be expected. As regards

the site of the proposed Fair, in the opinion of the CIRCULAR, New York is the only place that possesses the advantages that would ensure the success of the enterprise. These advantages were fully presented in the New York Times of August 25th in an interview with a traveling emissary of the permanent British Colonial Exhibition, and a gentlemen of experience in such matters. To rehearse his arguments—in the first place New York and its environs have a population to draw from three times as large as Chicago has. Second, the distance of Chicago from the Atlantic coast would certainly prevent many Europeans from exhibiting as well as many hundred thousand Americans in the Eastern states from attending. Of course, if New York were selected for the site large numbers in the West would be unable to come, but the fact remains that the center of culture is in the Middle states and a far larger proportion of the population of this section are of the fair-going kind than of the Western portion of the country. We can expect many more European visitors if we hold the Fair in the metropolis. And right here we come to the word that covers the whole question. New York is *the* metropolis of the country and Chicago is *a* metropolis—of a section. The difference is summed up in the words "the" and "a."

American Art.

THE IMPORTANCE OF THE QUESTION.

NO MORE interesting educational document has appeared of late than the first annual report of John Ward Stimson, Superintendent of the New York Institute for Artist-Artisans, 140 West 23d street, New York. As showing the general need of the times and the only practical method of supplying that need, we select a few of the most pungent paragraphs to lay before our readers:

ART'S CATHOLICITY AND DEMOCRACY.

"Let us take, again, the highest testimony upon certain other vital points before us. 'The *Catholicity of the Arts*,' says one ancient historian, is an *essential characteristic of every favorable epoch, i. e.,* their application equally to palace, cottage, cathedral or village church. The art we discover in the poetry and sculpture of Greeks we find in their architecture. The most modest Greek construction exhales a perfume of art as well as the richest temple. From the union of all the forces of France in the 12th century, says another, the great cathedrals rose, representing the social and intellectual movement of the age, and in the largest expression of old Gallic genius left the poetic and impressive embodiment of the religious sentiment to build a cathedral large enough for Humanity.' Still again another witness: 'The lay school of the 13th century was essentially *democratic*, everywhere and in everything—villager had as much pride in his little church as citizen in cathedral. In the humblest buildings it was often the *most evident*.' 'It is important,' says Le Duc, 'that all—especially artists—should perceive that art in architecture consists not in the employ of precious marble merely or accumulated ornament, so much as in *distinction of form* and in the *most honest and graceful way of doing* practical things. An epoch which makes art a luxury or appurtenance of privileged classes, does not possess the highest elements of civilization nor one of the *most essential qualities of public tranquility*. There are intellectual enjoyments and uses as well as material, and the former, like the latter, when exclusive generate harm. If *few* read, the crowd burns books (when it gets power) with the same passion it does palaces. If *all* read, books are respected and protected. So, to make art a luxury associated only with money, is dangerous alike to art and dilettantism. It is important to render it *catholic* and restore its influence *everywhere and in everything*.'

It is the acme of public folly, then, to give power to all without teaching principles of wisdom and beauty to all. In a republic founded upon *intelligent labor and intelligent votes* it becomes a very vital question! Certainly in our new 'world republic,' which claims to lead the van in the liberal and enlightened life of all its children, founded on the essential dignity of labor, and pledging them from the start a generous education for self-government and industrial success to attain the only aristocracy it recognizes, of patriotic service and self-support, we should be first to discard exploded feudal fallacies which consider art, religion and liberty the fad of quixotics, the monopoly of the few. Says the great English poet, artist and artisan, Wm. Morris: 'I do not want art for a *few* any more than religion for a *few* or liberty for a *few*. The democracy of art springs from the democracy of the people!'

ART IN AMERICA.

As to Americans, we are in some directions the oldest and most advanced, but crudest in taste and industrial skill. Van Brunt says: 'It is impossible to enter comparison without finding our society unfavorable to high thought, serious study and self-denial.' Our country needs earnest men, vitally in sympathy with American destiny, but broadly educated and balanced, comprehending Principles and disciplined by practice, tried in the fire and not found wanting, in whom the era will *repose confidence*. Art has been long enough rack-ridden by mechanicalism, conservatism, dilettantism, exploitation, without a redeeming idea. The last letters from the International Exhibition at Paris state frankly that 'The freedom of which we Americans boast, is found *associated with ignorance and slavery in industrial life*. Paying transportation *over and back* again, plus manufacturing costs and customs, added to millions yearly drained from us for foreign skill, we reach an approximate to the *colossal penalty we pay* for failing to develop *Art in ourselves*.' If we exported equal amount of taste-made-manufactures it would be honorable exchange, but exporting 'raws' and importing 'manufactured' is confession of creative inferiority, for which we pay the tribute of intellectual vassalage.

As civilization advances the preparation for life's struggle changes; what was not a necessity here a century ago is felt to be so now. Nations grow less solely agricultural and more manufactural, our work like others must become *more beautiful*. Americans find cost of living and competition increased, while markets are artificially cramped. Waste and the cost of the Rebellion burden us with debt, which means more must go to pay interest and principal and less to our families. Channels of unskilled labor are being glutted by crude immigration, skilled positions seized by imported foreigners with their alien affectations. The American must be more wisely educated or grow steadily poorer. Outrived abroad, neglected at home, blinded by the politician and monopolist, where is his hope save in his best industrial Art schools? In this direction (as with other nations) will be found his surest settlement of labor troubles, for it is the *acquisition and economy of power*. We are paying enough to misery, pauperism, police and parasites to redeem us a dozen times by proper schools for skill.

THE CENTENNIAL EXHIBITION.

Our Centennial Exhibition awoke us to this shame, which travel, competition, facilities of communication and labor convulsions have made clearer, while we pour our straightened earnings into the lap of tax-gatherers! We find ourselves in the midst of a wonderful revolution in the world's industry, and laboring under disadvantages which past training unfits us to meet, and for which antiquated systems and policies are utterly inadequate. The realms of skill are enlarging as in the golden ages gone, and Artist is designing for artificer. The leading civilizations are bestirring themselves and adjusting to new conditions, while we stand stupefied or sterile. Warning after warning goes neglected. Popular intelligence rises over the globe like the tide, and rolls the waves of the 19th Century upon our laggard life and impotent leaders at whose childish brooms or bauble hobbies it laughs, as the Ocean at the command of infatuated Canute. There is no lesson more emphatic in history, from the Tower of Babel to the wrecks of Samoa or the sad vale of Conemaugh, than the folly of founding the public weal upon blind Materialism and presumptuous Ambition, instead of Spirituality and Justice, or confiding it to the tender mercies of the careless dilettant, or dragging our rusty anchors of Conservatism and Greed till disaster overwhelms! Far nobler, from every point of view, to steam bravely out into the high seas of human brotherhood and co-operation by the force of inner fires of intelligence and cultivated skill! The race is not to the flashily 'swift' nor materially 'strong,' but to those large-minded and large-hearted efforts *nearest to the primal plans and sympathies of our Creator*. Man knows he is more than a machine and asks that his toil be enlightened and ennobled. The final word of Science is 'God *never wastes* and God *never fails*.' He has therefore never *carelessly* created Beauty to cover the face of sky and earth, nor *ruthlessly* planted in the heart of human nature those famishing cries which everywhere it utters for 'bread instead of stone,' for 'fish instead of serpents.'

In this year of our national reminder of patriots of the past, are there no *patriots of the present* to hearken with quicker sense than the dull ear of sordidness, this cry of our American yeomanry rising from mortgaged farms and crowded cities, and thousands of brave yet hard-pressed women staggering from moral or physical exposure at inappropriate and unfeminine toil, who ask us to open avenues of education and employment which shall engage their better faculties and 'protect' them and the country *organically* and *from within* against foreign competition, while enriching us by the creation, retention and economy of our wealth?

In brief summary, we Americans need Art training, broadly, practically and *immediately*. The Individual for stimulus, contentment, character. Home for the potency and charm of its atmosphere. Society to soften manners, develop amenities, refresh toil, refine its pleasure from vulgarity and vice. The State to perpetuate its glory and awaken patriotism, to make available her raw material and raw humanity, to inspire and direct industry, revoke oppressive imposts, brighten the monotony of a mechanical era, temper the tedium of routine, sweeten the asperities of puritan tradition. The whole World needs her as its universal language, its vehicle of approach by International Exhibition, in which we lose local bigotry, ignorance, conceit, through mutual appreciation and generous respect. It broadens the scope of human sympathies, enlarges religious conscience and intellectual horizon, becomes a practical philanthropy to thousands of darkened lives. To toiler at the factory, prisoner at the bureau, stooping apprentice and laden woman, country drudge and city accountant, weary mother and wondering child, it comes an angel of benediction and relief with its voices of spring, song of birds, odors of flowers, echoes of mountains. Garlanded with Joy and radiant in its Grace it opens its winning arms to all and welcomes us into its Beulah land of *BEAUTY which is the MUSEUM OF GOD!*

* * * * *

AN ORGANIC AMERICAN SYSTEM.

It is with a sense of pleasurable relief that we can now turn from these crimes of lese humanity in patent 'praying machines' or 'Art automatons,' to the real source of life popularity and success, which has attended our new system of AMERICAN ART EDUCATION. 'New' only in the sense that Truth and living Principles are ever 'new,' yet ever 'old.' 'American' in that specific sense that light, which is ever human and universal, can yet be assimilated by *local* organisms, and 'ours' personally only in the sense that organic growth adds ever something new, fresh, *individual, spontaneous*, to all true self-expression, vital arrangement, real Evolution.

Premising the truths we have elaborated in the preceding survey, we practically recognize a *Dualism* in Nature not alone expressible in terms of Eternity and Time; Space and Place; Statics and dynamics, Centripetal and Centrifugal force; but *Ropose and Action*; Conservatism and Progress; Tradition and Inspiration; Humanity and Self. We therefore strive to combine in teaching '*Matter and Mind*,' '*Realism and Idealism*,' '*Practice and Theory*,' '*Artisan and Artist*.' Indeed, on scientific and sociologic grounds, as well as ethic and esthetic, *our Ideal is to create the 'Artist-Artisan'*, whom we believe to be '*the Coming Man*,' i. e., a balanced temperament and development which *harmonizes instead of alienates mutually allied truths*. Without losing sight of respective roles, the Artist is made broader and more helpful by acquaintance with *practical media*. The Artisan is made more plastic and efficient by becoming *more artistic and sympathetic*. On similar grounds we welcome in class training the inter-influence of opposite temperament and sex, woman's work growing more valuable and stronger, man's more refined and sensitive by contact. Best of all, Art herself is vastly benefitted and broadened by universality and comparison, in which essential charms of the material and the ideal are distinguished. Students being taught to *do justice, not violence, to respective limitations and conditions*.

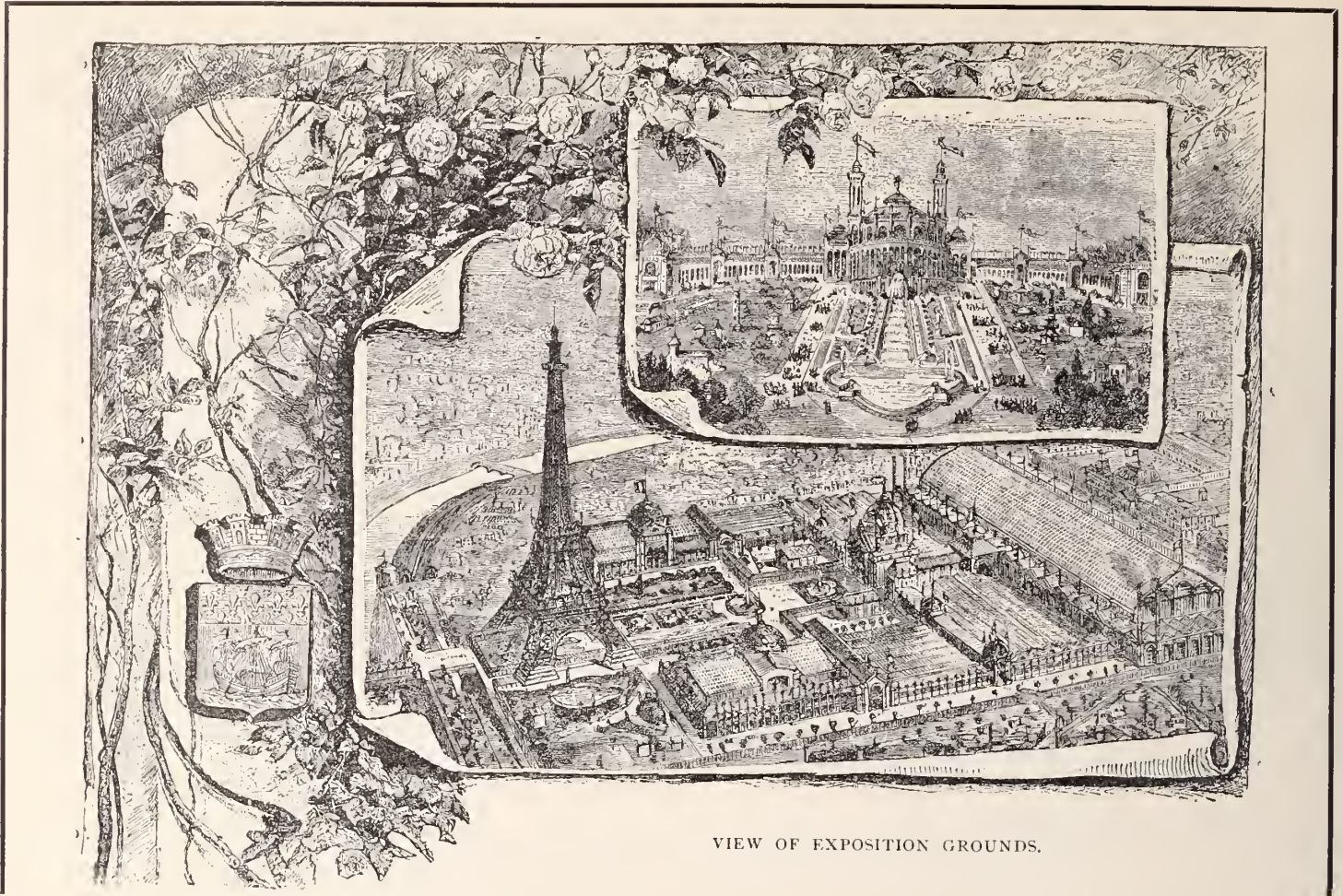

VIEW OF EXPOSITION GROUNDS.

Glimpses of the Exposition.

[FROM OUR SPECIAL CORRESPONDENT.]

PARIS, Aug. 15, 1889

THE MERIDEN CO'S EXHIBIT.

Let us describe a few more of the Meriden Britannia Co's wares, the variety of decoration of which has been a real cause of wonder to the members of the jury of awards. Worthy of mention is a pair of original candelabras in the shape of a vase and adorned in the Moorish style; also many candlesticks held by Cupids and Fauns. Then we remark an old silver cigar-box (9 inches high, with a capacity for holding 100 cigars) with a beautiful course of ornamental foliage in half-relief all round with interspaces, each occupied by a head of a Medusean character. On the top is a group consisting of a horse rampant on his back legs, and held strongly by a young man who appears to master him. Further we notice a great variety of whisk brooms, either in the Louis XV. style, or in embroidered old silver; some with Moorish decorations, etc. No end of letter-files and paper-knives, differently ornamented claim our attention, which soon wanders to a collection of splendid plates and dishes, decorated with shooting trophies, birds, dogs, and also sprigs of plants, sprays of flowers, and lovely vistas through luxuriant countries. All those of a very reasonable price, being made in placque, or enamelled copper, either with hammered back ground or etching, and finished off with inlaid gold or old silver. What a quantity of cake-baskets from 8 to 14 inches in length with engraved, chased, and other ornaments! Many of them are in satin finish. Shall we describe the casters, the tooth-pick holders, the flower-stands, the match-boxes, etc? It is like an endless fairy realm. To attempt an inventory of it would lead us to bewilderment and confusion.

The exhibit occupies one of the corners formed by the intersection of the two corridors that run through the American section. Davis, Collamore & Co. and the Gorham Manufacturing Co. occupy two of the other corners, while the Tiffany exhibit is in the center

of the square space. Perhaps more interest is centered in this locality than any other portion of the whole Exposition; certainly, it is the most interesting portion of the American section. There are three arches in the Meriden's structure which is higher than any enclosing the neighboring exhibits; the exhibit is in the form of a trapezoid or triangle with one of the angles cut off and is a striking display of quiet and beautiful colors, the combination of the cream and gold of the front producing a charming effect. Curtains of blue plush hang in each arch. The divan in the center is also of blue plush, and the walls are hung with tapestry of blue and gold, black and gold, and other blending colors. The floors are carpeted with Persian rugs.

STANDARD TIME SERVICE AND SETH THOMAS CLOCKS.

In the horological line, the Seth Thomas Clock Co.'s exhibit is by far the most interesting of the whole exposition, for any one who values, above all, perfect accuracy. To speak of their ordinary clocks alone, I can say, as a matter-of-fact, that they have been a cause of wonder to visitors of all ranks, who seem at a loss to understand how such reliable timekeepers can be marketed at so modest a price. Then, if we consider the two center clocks with uncased dials, and resting on a glass case stand, which arrangement allows all the works to be examined, we are still more impressed with the superior science applied in the productions of the Seth Thomas Clock Co. The fact that the Time Service of the U. S. Naval Observatory, at Washington, uses none but those timekeepers and has had them placed, at the Exposition, in the very center of the Government's exhibit is a very high tribute to the manufacturers.

Mr. William F. Gardner kindly explained to me the use of the various apparatus employed to illustrate the new system of Observatory time to which his name is attached, and the perfect application of which would, he said, be utterly impossible without the help of the Seth Thomas Co.'s clocks. I here reproduce Mr. Gardner's

explanations, word for word. "The basis of the system is that if an astronomical observatory, such as the U. S. Naval Observatory, at Washington, D. C., ascertains and sends out the standard time by electric signal, at stated periods, it may control any number of clocks within reach of these signals. Each supplemental or controlled clock is complete in itself, having its own train, weight and pendulum" (which, I may add, is not the case with the Popp system used in Paris); but, in addition it has an electro-magnet connected with the correcting apparatus, and a small gong. The clocks furnished by this company are made by the well-known Seth Thomas Clock Co. and are first-class timekeepers, having close rates. The electro-magnet, in each of them, is connected by means of a suitable wire

system." Before the Seth Thomas Co.'s transmitting clock struck twelve, Mr. Gardner set the signal apparatus going, and, having previously had all the clocks connected with the system mark a time too fast or too slow, he caused, through a slight touch, every hand of the above-mentioned timekeepers to run forwards or backwards on the dial to the number indicating twelve, at the same moment as the leading clock struck that hour, the operation being done within $\frac{8}{10}$ of a second. If it were extended to every place of importance in each town, the system would prove highly beneficial. It will, no doubt, be generally adopted in America, long before any other nation has seriously considered the matter. But no important result would be obtained without a transmitting timekeeper absolutely reliable;

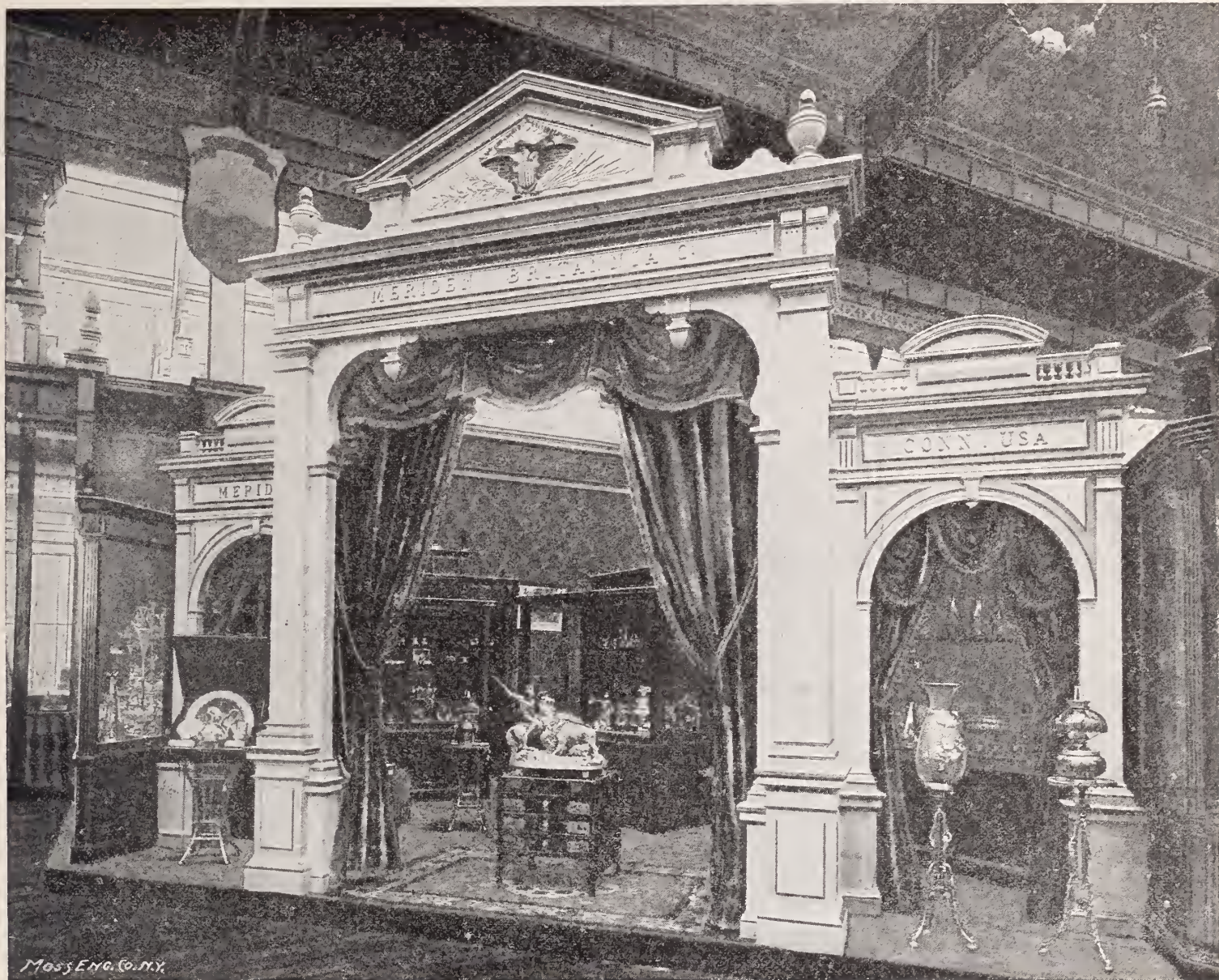

VIEW OF THE MERIDEN BRITANNIA COMPANY'S DISPLAY.

with the astronomical observatory (or other source of standard time) in such a manner that at certain hours an electric current will be transmitted over the wire, which by simple and peculiar appliances will cause the electro-magnet in each clock to move the hands of the clock to their correct position in accordance with the standard timekeeper at the observatory, or elsewhere. Thus it will be seen that, while one clock may be slow and another fast, all will be set exactly right by the electric current sent from the standard. This is done automatically by the regular time-signal. When signals are sent out by railway wire, no additional line is necessary, connections with the clocks being made at each station by the telegraph operator turning a small switch on his table at the proper moment. Thus is insured regular, uniform and accurate correction of all clocks in the

and I gathered from the interesting information which I obtained from Mr. Gardner that unless clocks of precision, like those of Seth Thomas & Co.'s be employed—these having been selected by several observatories for their value and accuracy—it is impossible to arrive at any result approaching perfection. While the above explanations were being given to me by the learned representative of the U. S. Naval Observatory, Mr. Russell B. Harrison, the United States President's son, came to see Mr. W. F. Gardner, and after he had examined with deep interest the eminently scientific exhibit, he showed himself highly pleased with the striking illustration, given on a comparatively limited scale, of that extensive system of Observatory Time. This is, no doubt, one of the most important features in the whole Exposition.

THE WATERBURY PYRAMID.

The Waterbury pyramid of watches (reproduced here) is just outside the further end of the United States section. On the hidden right hand side there is a square opening at the top of a low door which has a little counter. Placed as it is, the pyramid never fails to attract the visitors, and proves to be, decidedly, a capital adver-

tisement. This article), gives a thorough idea of its general effect. The exhibit occupies one of the four corners in the center of the American space. While the company have made no attempt at elaborateness of fittings or decoration, the effect of their plain, low cases, finished in ebony, together with the display of rich goods, is very striking, and the arrangement is commented upon as being the most perfect



THE WATERBURY PYRAMID.

tisement. The ground of the pyramidal portion of the display is of red, white and blue material. There are fully 1,700 watches contained in the exhibit.

THE GORHAM CO. EXHIBIT.

I cannot help mentioning the ever increasing success of the Gorham Mfg. Co.'s exhibit. The photo of their stand, (reproduced in

for its purposes of any exhibit in the whole Exposition. The frontal of the entrance is overhung with the United States flag and that of France, held together at the top and gracefully drooping on each side. The whole appearance, with the century vase (the most impressive single piece in the exhibit) in the center, is at once grand and elegant, and the visitor immediately realizes the prominent

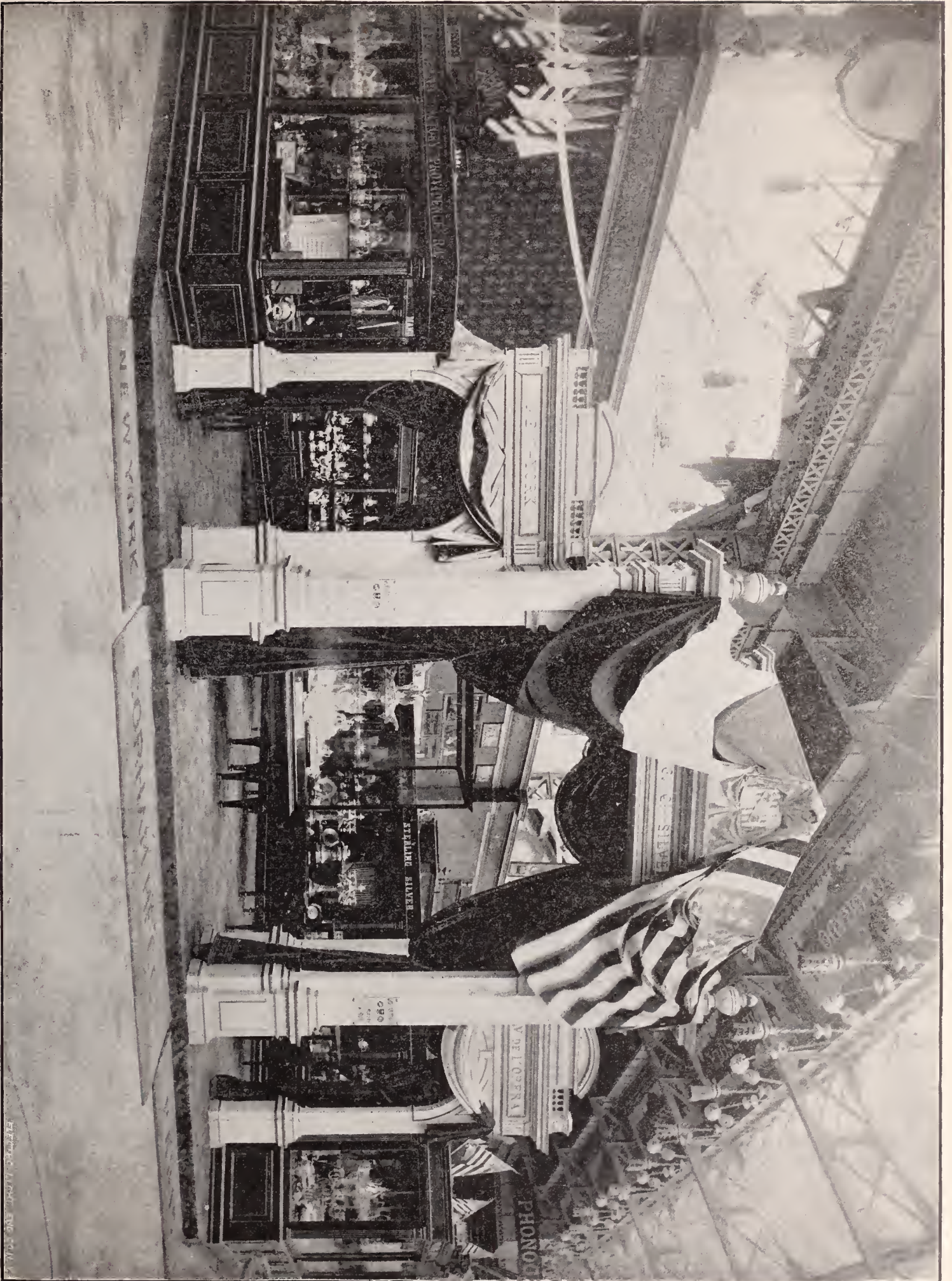

VIEW OF THE GORHAM MFG CO.'S EXHIBIT.

PHOTOGRAPH BY H. L. BROWN

NON-MAGNETIC WATCH CO.,

✧ OF ✧ AMERICA, ✧

SOLE OWNERS AND CONTROLLERS OF

THE CELEBRATED

Paillard Patent Non-Magnetic



Compensation Balance and Hair Spring,

which possess the durability and elasticity of the finest steel; are unaffected by moisture and heat, and are

Absolutely uninfluenced by Magnetism.

MANUFACTURERS OF

PLAIN AND COMPLICATED WATCHES,

Of superior construction and finish and containing the Paillard inventions

Full line of Gentlemen's Fine Watches; Ladies' Watches, Plain, Enameled and Diamond Decorated Chronographs; Split Seconds; Repeaters. Split Seconds with Minute Registers and Independent 1-5 Seconds, Calendars and all Combinations of the same.

OUR WATCHES LEAD THE WORLD!

Selection Packages sent to parties known to us or furnishing Satisfactory References.

FOR SALE BY ALL JOBBERS!

Non-Magnetic Watch Co. of America,

177 & 179 BROADWAY, NEW YORK.

A. C. SMITH, General Selling Agent,

position occupied by the Gorham Mfg. Co. in the Universal Exhibition, which really means—in the world.

Directly on the right as you enter, will be found a few rare examples of the finest *repoussé*, which have won the admiration of every one. A liberal minded French manufacturer observed that he found

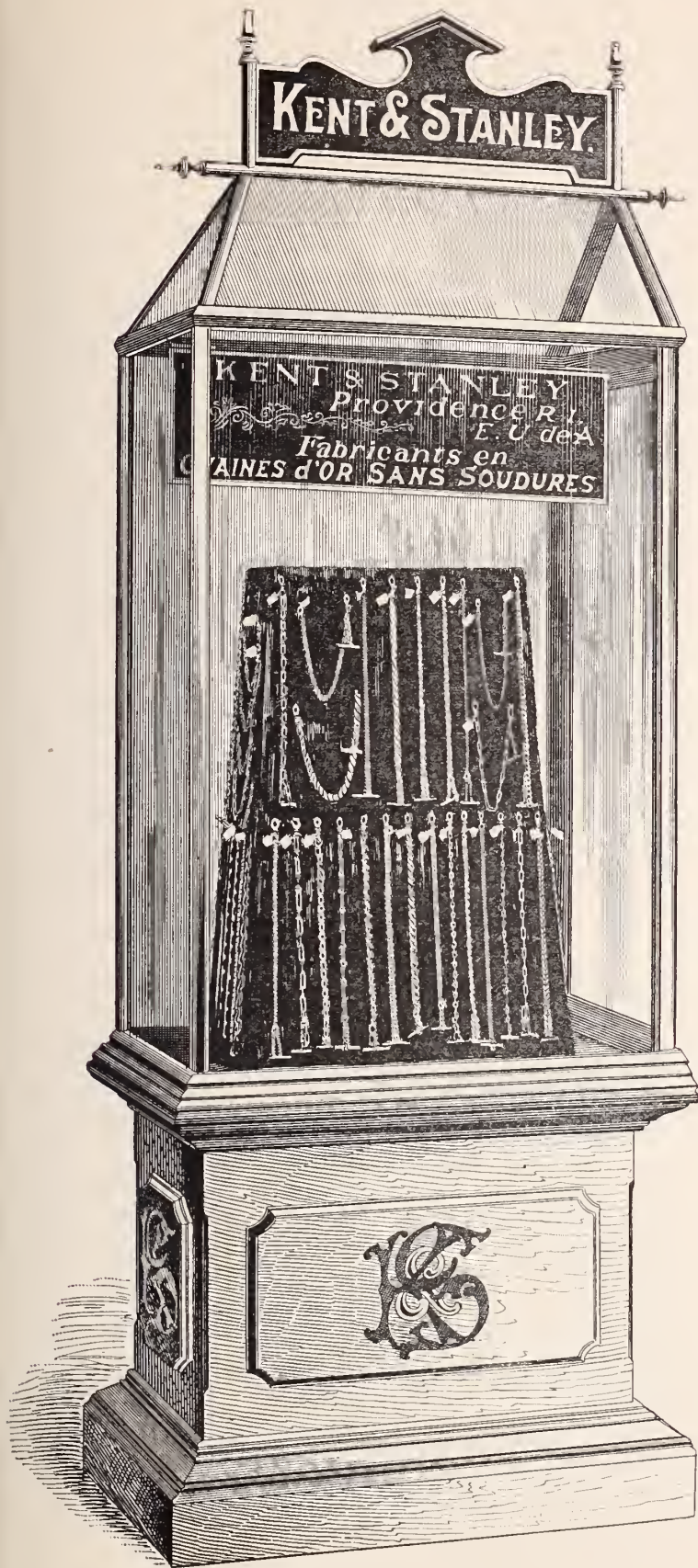

KENT & STANLEY'S CASE.

more that was absolutely new in design in the Gorham exhibit, than in the entire French section of silverware. As you proceed around the interior of this court, the next important subject that impresses one, is the large pair of Indian candelabra, of simple, yet grand design, and most beautifully chased, which were fully described in a

previous issue. These have already been sold for delivery after the close of the Exhibition. The tea set, consisting of kettle, pitcher and tray, executed in floral chasing of a peculiar character, has also displays the word *Vendu* (sold); in fact, the Gorham Company have been most successful with the sale of their largest and finest pieces, and some important orders already sent home for execution.

As you look carefully through the remaining cases, you become aware of the comprehensiveness of the display, and the manager claims to be able to show examples of every variety of articles and decoration made and executed by the company. The large cabinet chests of forks and spoons are almost unknown in the trade of Paris; they have been much admired, and all of the important ones sold. The display of silver mounted leather goods is large and attractive, and these productions have become popular.

I know, for a fact, that the members of the jury of rewards have greatly admired most of the company's pieces. I described to you in my last, the lovely tea and coffee sets, the stately candelabras and the exquisite mirrors. How characteristic are all these styles: the Versailles, the Dresden, etc., the two latest, one of which is called the Coligny, are magnificent specimens of the most refined Renaissance, applied to articles unknown in the sixteenth century; and the execution is such that Benvenuto Cellini himself, if he had attempted a work of that kind, which he never did on account of the fashion being different, could not possibly have surpassed that supreme delicacy of treatment. It does the greatest credit to the well known artist, F. A. Heller. What is especially remarkable in connection with this company is their policy of combining thorough artistic work with practical. It is really surprising to see in the same house complete table sets at once elegant and useful, side by side with bold productions of the most advanced kind of art, such as Heller's Vintage group (4 meters 30 centimeter high, modelled in plaster) which represents Bacchantes and Fauns dancing around an Indian Bacchus. I sincerely assert that I do not know of any other living artist who could give such life to a composition of that kind. Carpeaux, alone, who made the *groupe de la danse* (placed to the right in front of the Opera) could have done it. I really find it almost impossible to bring this paragraph to a close, and I am sure I shall have to mention again the Gorham Co. exhibit in my next letter.

AMONG THE FRENCH JEWELERS.

In passing through the jewelers' section let us notice Teterger's spray of geraniums in enamel, of so perfect a rendering, so light and natural. Gustave Sandoz exhibits some lovely pieces. His corsage garniture in the shape of a bold yet regular ornament, bordering the top of a low-neck bodice, and gracefully coursing down to the center of the waist, has an elegant effect. His bracelet divided in small pieces and decorated in enamel of a tender hue, is very pretty. A rather attractive glass case is that of Mr. Fornet, of Bourg-en-Bresse, (near Lyons), who exhibits some special kinds of articles called Emaux Bressans, whose style was already known and in very great favor in the Gallo-Roman period. They consist of rings, brooches, bracelets, earrings, necklaces, etc., in vermeil filigree and enamel. The center of the display is occupied by a sweet little mirror, underneath which we remark an inkstand of a pretty design. Mr. Fornet has greatly changed that peculiar genre from the old-fashioned style, and it is now somewhat different, chiefly consisting of enamel on *champlevé*. Although that abandonment of an ancient track may be amply justified from a business point of view, yet I cannot help regretting the old crosses in the shape of a double hatchet, the hearts with pendants, the rings so naively ornamented, and the vari-colored jewels called *papillons*, which not many years ago, were still worn in the southern part of France.

THE IMPERIAL DIAMOND.

A tiny glass case raised prominently on a stand in the center of the jewelers' court contains the largest diamond ever seen, worth between six and ten million francs, according to the opportunity of

sale. It weighs 180 karats; thus it weighs 44 karats more than the Regent, and 74 karats more than the Kohinoor. It was found at the Cape and belongs to an Anglo-French syndicate. When it was shown to the Queen of England, some time since, the Prince of Wales, being present, exclaimed: "*This is an Imperial diamond.*" From that moment the unique stone has been considered as baptized by that name and will, no doubt, preserve it hereafter. It was cut

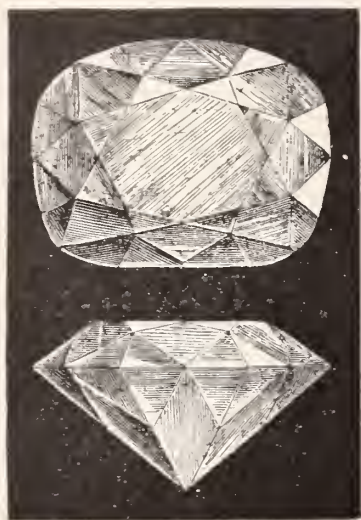

THE IMPERIAL DIAMOND.

at Amsterdam under the care of three of the foremost lapidaries of that city. The Queen of Holland is said to have witnessed the grinding of the first facet. Eighteen months were required to bring it from its primitive appearance to its present one. In a rough state this stone weighed 475 karats. In order to give the finished stone a beautiful shape, a piece weighing 45 karats, which was afterwards cut into a brilliant weighing 20 karats, was split from it. At the Exposition the Imperial diamond is fixed on a wire to a revolving velvet stand which turns slowly around, favoring a constant circle of admirers with its sparkling rays.

IN THE SWISS SECTION.

The Swiss exhibit of watches can hardly be described in a few lines. All I can do in this letter is to offer you a kind of introduction to a more complete article. I intend to give you next month a detailed account of all the most interesting displays, such as those of Geo. Agassiz, E. Francillon, Longines, etc. The glass case of Patek, Philippe & Co., (Geneva), contains some original pieces. I have noticed in it a wild rose encircling a tiny watch. From the gold stalk shoots three leaves and a bud, all made of brilliants. Another watch is concealed in the very heart of a daisy, underneath a pearl which has to be lifted to disclose the dial. But the attention is particularly brought to bear upon the display showing the difference in the processes employed for the making of all essential parts of watches: movements, regulators, etc. We shall, later on, have to note the results obtained at Chaux-de-Fonds, Locle, Geneva, etc. We must also have a look at musical boxes which are a very important and interesting item in the Swiss section.

IN THE BRITISH SECTION.

A curious feature of the English court is the entrance to the Victoria, (Australia), section. It is a very stately arch, all in gilt, with courses of elaborate ornaments in high and low reliefs. This remarkable piece of architecture is supposed to give an exact idea of what could be done with the total quantity of gold obtained since the foundation of the colony in 1851. The total weight has been 56,000,000 ozs., representing a value of one hundred million dollars.

An original feature in the British sections is the stand of J. M. Crough, Royal Scotch jeweler, of Regent street, London. I am hardly prepared to attest on oath that his Highland jewelry is of the exact style worn by Burns' bonny lassies; but those brooches in the

shape of dirks and claymores, and those vinaigrettes made of horn are very pretty. The exhibits contains no end of necklaces, earrings, bracelets, etc., consisting mainly of Scotch fancy stones, and Mr. Crough says he has already sold a large quantity of his sweet little trefoils in Connemara marble.

The largest and most varied display in the British section is that of the Goldsmiths and Silversmiths' Co. of London, which is of a most magnificent and glittering character. The best products of their several factories, as to quality and finish are shown. Although clocks and watches are among the principal productions of this company, but few are seen, the exhibit consisting principally of electro plate, sterling silver, table cutlery, jewelry, diamond ornaments, etc.

Gillett & Johnston, Croydon, England, exhibit a very beautiful case, a model of one of their patent carillon machines, for which the firm is noted. It attracts very much attention.

The Goldsmiths' Alliance make a very worthy show of silver-plated wares, consisting of table services, tea services, and individual pieces such as waiters, currant scoops, muffineers, soufflet dishes, wine funnels, butter coolers, etc.

An eight-day watch called an "Octometer," and built by Weill & Harburg, Holborn Circus, London, is displayed. An assortment of such are to be seen, a prominent feature of them being the black lettering on the dial.

If we go up the elegant flight of stairs leading from the central gallery to the balcony which extends around the Palais des Machines, we soon find before us the pavilion of Mr. L. Latine, well known lapidary from Anvers, where the Shah of Persia bought, the other day, during his rambling promenade through the Exposition, a black diamond worth \$6,400, which he took with him. Among the enormous quantity of diamonds exhibited there, all showing new faceting patterns, visitors who understand the matter especially remark a cross made of one stone. That piece is absolutely invaluable, if we consider, not only the intrinsic worth and wasting of precious substance, but also the time and the superior skill spent on it.

FRANCUS.

The Jewelers' Security Alliance

President, DAVID C. DODD, JR.

First Vice-President, AUGUSTUS K. SLOAN.....Of Carter, Sloan & Co.

Second Vice-President, HENRY HAYES.....Of Brooklyn Watch Case Co.

Third Vice-President, DAVID UNTERMAYER.....Of Keller & Untermeyer.

Treasurer, CHAS. G. LEWIS.....Of Randel, Baremore & Billings.

Secretary, GEO. H. HODENPYL.....Of Hodenpyl & Sons.

EXECUTIVE COMMITTEE.

J. B. BOWDEN, *Chairman*.....Of J. B. Bowden & Co.

C. G. ALFORD.....Of C. G. Alford & Co.

N. H. WHITE.....Of N. H. White.

F. KROEBER.....Of F. Kroeber Clock Co.

SILAS STUART.....Of Silas Stuart.

H. H. BUTTS.....Of H. W. Wheeler & Co.

EXAMINING FINANCE COMMITTEE.

J. P. SNOW.....Of G. & S. Owen & Co.

HENRY ABBOTT.....Of Henry Abbott.

For further information, Application Blanks for Membership, By-Laws, etc., Address
P. O. Box 3277. 170 Broadway, New York.

The regular monthly meeting of the Executive Committee was held at the Alliance office on the 8th inst. There were present David C. Dodd, Jr., President, A. K. Sloan and David Untermeyer, Vice-Presidents, J. B. Bowden, Chairman, and Messrs. White, Stuart, and Geo. H. Hodenpyl, Secretary.

Chas. A. Roush, Baltimore, Md., was admitted to membership; also on July 30, J. C. Watts & Co., East Saginaw, Mich.; Henry J. Friedlein, Saginaw City, Mich.; J. W. Browning, Windsor Locks, Conn.; Brumer Bros., Clinton, Iowa; C. L. Haskins & Co., Saratoga Springs, N. Y.; and Constantine Lucius, 841 Sixth avenue, New York, N. Y.



[FROM OUR SPECIAL CORRESPONDENT.]

THE HOLIDAY SEASON.—COMPETITION BECOMING KEENER.—SMALL STERLING SILVERWARE SUPERSEDING ELECTRO-PLATE.—THE SHAH'S VISIT AND ITS DISAPPOINTMENT TO THE JEWELRY TRADE.—A NAUTICAL SCARF PIN.—EAR RINGS AGAIN IN FASHION.—ROYAL WEDDING GIFTS.—THE EXPEDITION OF THE SCRIPP'S LEAGUE.

LONDON, Aug. 10, 1889.

Considering that July is rather a favorite month for those who can choose their own time in which to take a holiday, and that the present week commenced with the fourth of our bank holidays for the year, our manufacturers have not much to complain about in the volume of the business done. These holidays, by which I mean the national holidays—bank holidays—have a double effect on our trades. In the first place they are taken advantage of by many manufacturers for enjoyment of a short holiday themselves, and on the other hand they induce thousands of persons to travel about and to spend money in jewelry that they would not otherwise spend. I am very glad to be able to report that our London and Birmingham manufacturing houses are much more hopeful than I have known them to be for some time. There is the usual amount of complaining that seems chronic in manufacturing jewelers, but I think those to be the best judges who are preparing for a good autumn trade by keeping up their stocks. I know some who are doing this and who are keeping their workmen at full time, although orders for immediate delivery are not so plentiful.

"HAWKING" ON THE INCREASE.

London houses are remarking upon the severity of the present competition, which is said to be keener than any previously experienced. There is no doubt that the facilities for rapid production have greatly contributed to this. It is equally true that the means now adopted for effecting sales are greatly accelerating the intensity of the competition. I refer to the increasing practice of wholesale dealers (jobbers) and manufacturers taking large assortments with them from shop to shop operating sales direct from stock instead of booking orders for delivery as was formerly the practice. I confess I do not see how this is to be altered now. It might have been prevented, but the custom once adopted is more likely to increase than diminish. A very few years ago it would have been considered *infra dig*: but the conditions of business seem to have undergone a complete change. I am not a very old man but I can remember the time when some of our principal manufacturers would not have done by request from a customer, that which they are now doing every day to dealers whom they wish to make customers. I will not take upon myself to actually condemn the practice, although I do not like it. We are indebted to this practice (I do not like to call it "hawking," though it would be so designated if fruit or tinware was the commodities) for two results—namely: The quantity of jewelry now sold and the miserable prices obtained for it. There is jewelry and jewelry: I am referring now to the bulk of the trade done. The higher class of business is, you will easily understand, not so amenable to these conditions. In that branch prices are more evenly regulated, but the extent of trade being done is not increasing, indeed is hardly being maintained.

STERLING SILVERWARE IN DEMAND

There is a very perceptible improvement in the demand for silversmiths' work and this it is asserted that the increased demand would be very considerable if the duty were removed. There is a constantly growing demand for "nickel silver" and "German silver"

goods; prices are very low but the sales are brisk. Reverting to the duty I find from statistics issued for the year ending 31st March last, that duty was paid for the year 1889 on 90,000 ounces more than the quantity paid for the year ending 31st March, 1888. The increase has been in respect of our home consumption, as the same returns show that there has been a falling off in the export trade. The decrease in the exports is a dead loss of trade, while the increase in the home trade may, perhaps, be regarded as a change in the character of the business done. This change may be explained by the fact that small silver articles of ornament and utility for the table are now taking the place of the large electro-plate pieces that have had such a good run. This substitution of 'sterling' for 'imitation' articles is in my opinion a good indication of the improvement of the general trade of the country. These silver goods may be classed as luxuries because they are silver: for all purposes of utility plated goods are just as serviceable. The taste and the desire for these better goods are as strong as ever, perhaps stronger. The indulgence of it has been curtailed by the reduced funds available for such a purpose. But if the present much appreciated improvement in the general business of the country continues, the demand for luxuries such as our trade supply will be greatly increased.

THE SHAH OF PERSIA'S VISIT.

It was generally expected that the visit of the Shah (we have had to speak of him so much lately that this short title is all we have time to use) would cause something like activity in certain branches of our industries. Our West End tradesmen had been preparing for a good customer and are greatly disappointed at the small number and poor value of his purchases. It was soon discovered that he had brought with him a large assortment of Persian jewelry larger in fact than his generosity required, for he is reported to have taken a considerable quantity back with him. He was accompanied by some of his native jewelers. It is not known whether this visit was intended to be an educational one in a business sense, or not. From what I have heard, from others who have heard, it seems that these gentlemen accepted every opportunity of disparaging every English production in their line. I cannot answer for the truth of this report, but as the total amount expended by the Shah in jewelry amounted only to a little over £200 and as many of these purchases were presents to be given in this country, he does not seem to have greatly fancied our British jewelry for its own sake. However if his Majesty did not spend much money himself, he causes others to do so and thus our retailers have derived some benefit from his visit if not so direct and to such an extent as they expected.

A PRETTY SCARF PIN.

I suppose the Naval Review held this week is responsible for the appearance of a pretty scarfpin formed of the trident of Neptune. The middle prong is set with turquoise and the others with pearls. It is a neat pin even for those who have not nautical proclivities. There are to be seen many devices for showy scarfpins and brooches, and some of them are very attractive. The long white ties now so fashionable for gentlemen's out-door wear require a pin of some kind, and hence the supply.

LADIES' COLLAR STUDS.

Another opening for our inventive jewelers this summer is found in the demand for collar studs and front studs for ladies' wear. Ladies are now wearing neat tailor made light costumes, consisting of a sort of jacket body with an open front similar to that of our vests, and of course inside this body is seen a spotless white chemise, showing the studs I have mentioned.

THE EARRING REVIVED.

This summer has witnessed the restoration to something like its former position of a good friend of the jeweler and silversmith—1

mean the earring. Long discarded and out of fashion, earrings are to be met with frequently now. I have seen some veritable old stagers—the real originals brought out again I should think. There are, however, some new designs that are not at all becoming. I really don't like the long pendants in fashion in some quarters. They look heavy if they are not so; though they may not be so heavy as they seem. I am sure they are cruelly heavy for the delicate auricles sometimes compelled to bear them. If the beautiful shell-like, tinted little ear must have an ornament, let it be a solitary gem close to the lobe and with as little setting as possible, that little being as light as possible. Presents of earrings are found in the lists of gifts at all fashionable weddings and a beautiful pair was among the gifts of the Duchess of Fife the other day.

A FEW OF THE ROYAL WEDDING GIFTS.

I was among the fortunate few who were permitted to inspect the presents to that very fortunate young lady, the Princess Louise of Wales. If I had a whole number of THE JEWELERS' CIRCULAR at my disposal I might, perhaps, undertake a description of them. The spectacle which greeted my eye on entering the dining room where the many beautiful and costly offerings were spread out, was one to be remembered. Down the center of the spacious apartment was the family dining-table drawn out to its full extent. Arranged upon this, with more care to artistic effect than is usual in such cases, were all the articles of jewelry and plate which were received, as well as the china, glass, portraits, dressing-cases, and other small presents, of which there was an infinite variety. On smaller tables around the room were arranged many works of art, and on the floor stood the more bulky souvenirs. Almost the first object that attracted attention, was a copy, in solid silver, of Landseer's picture, "Hunting the Stag." The model, which was nearly two feet high, was executed with remarkable care and fidelity, and is one of the features of the collection. The subject was chosen by the Prince of Wales, the donor, as being peculiarly appropriate in view of the Scottish descent of the bridegroom. A considerable proportion of the space at the upper end of the table was devoted to jewelry. The blaze of diamonds was particularly striking, whilst nearly every kind of precious stone could be seen in brooch or bracelet. The place of honor was accorded to a superb diamond tiara, the Earl of Fife's gift to his bride. The stones, of which there are a great number, were specially selected for their purity, and the larger brilliants—or briolettes, as they are technically known from the manner in which they are cut—were of unusual size, exceeding 10-carats in more than one instance. A diamond parure, designed on similar lines, and containing equally valuable stones, was also presented by the bridegroom. The Prince and Princess of Wales give their daughter a magnificent diamond necklace to complete the set, and there was a profusion of diamond brooches, stars, arrows, etc., from other well-wishers.

THE SCRIPP'S LEAGUE.

While I was in Manchester the American workingmen, the representatives from the Scripp's League, sent to visit prominent manufacturing centers here and on the continent—came to the hotel I always stop at—the Trevelyan, Corporation street. I had, therefore, an opportunity, though a brief one, of conversing with some of the party. There were 44 of them (including four females) and they are understood to represent every branch of your industries. I tried to get hold of the "jeweler" but could not find him. Their stay in Manchester was brief—arriving in the afternoon, a reception by the Mayor, visiting some half-dozen factories, inspecting the Manchester Ship Canal and leaving for London the following evening. The trip will give them a very instructive and enjoyable holiday, I presume free of all cost to themselves, and I do not blame them for taking it. I shall be glad to learn if the jewelry trade on your side is interested in, or benefitted by it

VIGILANT.



[FROM OUR SPECIAL CORRESPONDENT.]

CHICAGO, August 20, 1889.

Your observer has just returned from a tour through Iowa, Nebraska, Kansas, Missouri and Colorado, to find the Chicago jobbing jewelers contented and busy with the beginning of fall trade. They all report that for the past week or two business has begun to rush, and from personal observations your observer can assure them that if big crops—possibly the largest crops the Western States have ever known—will give purchasing power to the retail trade of the West, Chicago jobbers will be kept as busy as bees until January.

The retail jewelers in all of these States appear energetic and prosperous, and while it is no news, it is worth while to remember that there are few more attractive jewelry establishments in either New York, Chicago or St. Louis than can be found in Kansas City, Omaha and Denver. It was gratifying to learn from Eugene Jaccard, son of D. C. Jaccard, of the big St. Louis house, that the Kansas City enterprise inaugurated by him a few months ago has proven successful beyond all anticipation. R. J. Gilbert, the secretary of this Kansas City Watch & Jewelry Co., also received his training from the parent house in St. Louis, while J. Russ Mercer, the treasurer of the company, has been identified with the jewelry trade of Kansas City for the past nine years. Mr. Jaccard will be in New York until about September 7th. His house carries a stock of about \$125,000, and from business done since the store opened, they say they can safely count upon a business of from \$150,000 to \$175,000 per annum. Not only have they been agreeably surprised in the volume of sales, but also in the quality of wares demanded by Western trade. Many of the fine pieces sent out from New York "on memorandum" found ready sale, and encouraged the arrangement of an art-room in the rear of the store, which is set apart for bronzes, marble pieces, music boxes and art wares.

Even the little city of Colorado Springs has a half dozen well stocked and tastefully arranged exclusive jewelry establishments, and five or six miles away, at the very foot of Pike's Peak, are quite a number of bazaars dealing principally in jewelry, but handling also mineral specimens and native furs. The larger of these is owned by J. G. Hiestand, who nine years ago, while studying mineralogy in Philadelphia, got the Western fever, and went out to the Rockies to collect specimens of minerals. He never came back, and at Manitou makes a specialty of a lapidary department, where he cuts and polishes stone, agates and jewels found in the mountains. A topaz weighing thirty pounds was being cut in slabs when your observer called, and a crowd of on-lookers (some of whom became purchasers) were admiring the set and unset crystals which filled several large show-cases. A file of THE JEWELERS' CIRCULAR occupied a conspicuous position, and the completeness of Hiestand's bazaar would attract attention in Fifth Avenue, New York.

Amongst the disagreeable happenings during your observer's absence was the failure of Max Young, which occurred on August 1st, and was followed, on the 9th inst., by his assignment, with liabilities, of \$25,000 and nominal assets of \$17,000. Max, who is, perhaps, forty years old, is well liked and respected by the trade here, who all regret that his two years of over ambition and hard work should have, after all, the result of worse than nothing. Otto Young, his brother, has an income of not less than \$200,000 a year, and has had a career of uninterrupted prosperity since the days when he travelled for the fancy goods house of Hecht Bros., of New York. He could spare \$25,000 without missing it, and perhaps when it comes to a settlement he will be found ready to place Max, who is his only brother, on a sure footing.

Mr. H. S. Peck, the busy manager of the Waterbury Clock Co., was

found superintending the sending off of six thousand of this company's annual catalogue for '89.

The Ansonia Clock Co. are fully equipped in their new quarters, and particularly noticeable is the line of white onyx clocks introduced by them about a year ago. The line has received several new additions, and ranges now in price from \$15 to \$60. These clocks have achieved a wide popularity.

The Chicago Horological Institute have begun the fall term with pupils from all over the United States, and even from South America, England and Russia. One of the scholars, by name C. F. Batchelder, from the little town of Milton, Fla., has just finished a 16-size sweep second chronometer, and the beauty of the workmanship is a striking example of the proficiency attained by the scholars of this school. Nothing need be said of the engraving department other than to announce that J. B. Wiggins is its chief instructor. He has done the greater part of the engraving for Chicago jewelers for close on to a quarter of a century, still remaining at the head of his profession.

The Protection Watch Co. has been incorporated, with a capital stock of \$150,000, within the month. E. S. Cory, G. D. Chettendon and G. G. Underwood figure as the incorporators.

The Jewelers' Distributing Co., incorporated at Rockford, Ill., recently, is but another name for the Jewelers' Guild, in which A. B. Boynton, the Chicago jeweler, has become interested, for the reason that his brother, W. N. Boynton, is the Guild's manager. The Jewelers' Distributing Co. has a capital stock of \$50,000, with W. N. Boynton, Geo. B. Kelly and C. J. Taggart for its incorporators.

Another of the month's corporations is the Justice Jobbing Co. The name indicating fair play does not spring from any spread-eagle idea, but signifies that W. M. Justice is the founder of the company. With him are interested G. N. Fitts, M. R. Hart and John Brison. The capital stock is \$50,000, and they have fitted up No. 182 State street with watch cases and movements very attractively.

The Hale building, at the corner of State and Washington streets, caught fire in the early part of the month, and gave quite a scare to Messrs. Giles, Bro. & Co., O. W. Wallis & Co. and Hart & Co., none of whom were scorched, though receiving more or less damage from water. O. W. Wallis & Co. are the successors of Cogswell & Wallis, and had just finished the refitting of their premises.

Giles, Bro. & Co. are adding a fine stationery and engraving department to their jewelry business. It will be under the charge of Mr. Fred H. Smith, for some time previous with Brentano Bros., Chicago.

Quite a little interest has been taken in the recent decision of our Federal Court, which reduces the duty heretofore paid on opera glasses taken out of bond here from 45 to 25 per cent., it now being decreed that mother of pearl cases forming the larger part of their make-up, they should not be classed as "manufactured metal and glass."

Another legal case which is interesting to our jewelers is the awarding of \$7,615 damages to Perry Bros. It will be remembered that a sample trunk containing jewelry to the above amount was wrecked on the Wabash, St. Louis & Pacific Railway, and owing to the burning of the baggage car, the trunk, when finally recovered, contained but a mass of molten metal, worth, perhaps, \$600. The award covers the full amount claimed.

The plans for the gymnasium and amusement hall to be built at once by the Elgin Watch Co. at Elgin, have been approved. The dimensions of the building are to be 45x104, four stories in height. The material is white brick trimmed with terra cotta. The roof is to be of slate and a tower will rise from the southeast corner. The amusement hall, in which will be given lectures, dancing parties and theatrical entertainment, will occupy the entire second floor. The gymnasium itself will take all of the third floor, while the main floor will be used for lockers, toilet rooms, offices and a band room, which of itself occupies considerable space. The cost of the building will be \$30,000 and creates a much needed means of exercise, which

the sedentary pursuit of watch making renders indispensable.

Spaulding & Co., although established as the successors of Matson & Co. not yet a year, have become recognized as a house capable of executing orders for everything which can be fashioned from the precious metals. Up to date this one establishment has received orders for no less than 17 sterling silver prize cups, each costing from \$100 to \$400, to be awarded at the American Horse Show which meets here from October 30 to November 9. These 17 cups are in addition to the prize costing \$500, and contributed by Spaulding & Co. themselves.

Employees of the Meriden Britannia Co. are expert ball tossers as well as silverware men; the base ball club of this company stands at the head of the commercial league, which includes all branches of trade represented in Chicago.

A large number of petty thievings have been reported by Chicago jewelers within the month; the only one held to the criminal court was the case of Mary Marthula. Mary, with two girl companions, asked to be shown some gold rings at Adolph Lurie's jewelry store and when a tray full was handed her for inspection, she made a quick selection of three and decamped. She could not furnish \$200 bail and is therefore repenting her act in solitude.

M. N. Burchard, the western manager of Simpson, Hall, Miller & Co.'s business, has just got back from his vacation spent at Mackinaw Island.

E. W. Prentiss, of the Gorham Manufacturing Co., has returned from his New York trip but is off on another one (West), from which September 1 will see him returned.

This pretty well covers the trade gossip of the month excepting the interest taken by Chicago's jewelers in the procurement for this city of the World's fair in 1892. C. D. Peacock, the well-known retailer, has been put at the head of the jobbing jewelers' committee, associated with Benjamin Allen and D. D. Roddin. Those commissioned to push on the work amongst the retail jewelers are J. B. Mayo, C. K. Giles and Frank Hyman. Of course, all our jewelers are in favor of this, their own town, but with the western agencies of New York houses the case is a queer one. The western managers, of course, are all enthusiastic over the advantages of this spot, but they durst not say much about it, because they have a reasonable suspicion that those at the New York factory will come out strong for that city. It is supposed here that New York feels sure of the prize, but we think it will be after a harder struggle than you Gothamites look for.

One of the brothers Weiskopf, of Kenosha, Wis., called upon the trade here recently. On August 8 E. E. Chandler, one of the leading jewelers of Boone, Iowa, accompanied by one of his sons, visited Chicago en route to visit relatives in Wisconsin. J. K. Bassy came here all the way from Albuquerque, N. M. From points nearer by came John Erbanon, of Batavia, Ill.; J. F. Lindbau, of Moline, Ill.; J. W. Brill, Danville, Ill.; W. R. Forbes, Portage, Wis.; Montague & Co., Duluth, Minn.

Lapp & Flershem, the "busiest house in America," of 92-98 State street, have a novel advertisement in this issue of THE CIRCULAR, one that very aptly illustrates their well-known push and enterprise. Their large establishment is a veritable beehive in every respect save one—there are no drones in it and no drones enter it. Their customers are as wide-awake as they themselves are, too, and know when they are well served.

THE CIRCULAR'S OBSERVER.

EXPLANATION OF TERMS.—The distance between holes is called the "distance of centers." A line drawn between the holes is called the "line of centers." The "pitch surfaces" in depthing are those surfaces of a pair of moving pieces which touch each other, when motion is communicated by rolling contact. If we take away the working points of the teeth of the wheel and the rounds of the pinion leaves, the wheel and pinion will be reduced to their pitch surfaces. The radius of the pitch circle of a wheel is called the "geometrical radius," that of a circle touching the crests of the teeth the "real radius," and the difference between those radii the "addendum."



[FROM OUR SPECIAL CORRESPONDENT.]

PHILADELPHIA, Aug. 20, 1889.

Quaker City jewelers are beginning to feel the pulsings of the fall activity already, and most of them regard the future with complacency. One of the most important of recent events here is the organization of the "American Horological Institute," of which E. J. Beach is president and W. H. Dotter, secretary. The school is destined to supply the growing demand among the youth of our country for thorough, scientific training in horology. The west has anticipated the east in this work and can boast of several very creditable schools of this character. Heretofore it has been almost impossible for those residing in the eastern states to get the needed instruction to fit them for the bench without going to Europe or to the west for it. Now, however, judging from the prospectus of the American Horological Institute and the enterprise of its founders, Philadelphia will soon have a first-class watchmaker's school. The term opens on October 1st, and any who desire further information should write to the secretary, W. H. Dotter, or visit him at 531 Arch street. Mr. Dotter states that many branches of the jewelers' art including engraving, stone setting, etc., will be taught by competent specialists, and in the watchmaking department he asserts positively that the instruction will be unsurpassed in this or any other country. Many tools and instruments of precision will be employed which are now unknown to the fraternity.

I. Bedichimer, 618 Chestnut street, the well-known manufacturer of masonic marks, emblems and society badges, is busy getting up special badges for the triennial conclave of the Knights Templar, to be held at Washington, in October. Mr. Bedichimer is taking a leading position in his line, by dint of his indefatigable industry, his fair dealing and the reasonable prices at which he is enabled to sell his goods. His experience covers a period of about twenty-five years, and he is regarded as an authority in matters pertaining to the symbols of masonry and in badge lore generally. He shows on another page probably the most unique advertisement of masonic goods that THE CIRCULAR has ever had the pleasure of laying before its readers.

Henry Troemner, the manufacturer of jewelers' scales and weights, is still in Europe and will not return before the middle of next month.

The National Optical Co. state that they are pushed to the utmost to fill the orders they are receiving for their "Royal Alloy" and patent interchangeable steel spectacle. The new eyeglass which they are putting on the market seems likely to prove a great success.

Until the recent hot spell, the large retail stores enjoyed a good trade for the summer season, but the heat of the past few days has driven shoppers back to the sea shore or to the mountains.

M. Zineman, of M. Zineman & Bro., and his corps of travelers and assistants, have buckled down to work again after a brief period of rest. The salesmen are sending in large orders for the popular "Diamanta" spectacles and all bodes well for a remarkably successful season with this stirring house.

Charles De Young, 704 Chestnut street, is advertising a closing-out sale preparatory to retiring from the retail business.

David F. Conover, has the sympathy of the trade in the loss of an older brother who died a few days ago.

Westcott & Bailey, the new retail firm, will open their store in a few days, both partners having been absent in Europe buying goods.

The National Watch Case Co., 715-19 Arch street, add their testimony to the volume that bears witness to the general improvement in the wholesale line.

E. Fox, of Queen & Co., is enjoying a well earned vacation.

Albert Zugsmith, jewelers' findings, 907 Arch st., has a novelty in the watch box line that is becoming very popular with the retail trade. It is called the "Silver Shell" watch box and is intended to set off watches to the best advantage when displayed in the show window. They are silver plated, both bright and oxidized finish, and are lined with fine silk plush. The price is so reasonable that any jeweler can well afford to make his show window more attractive by investing in them.



[FROM OUR SPECIAL CORRESPONDENT.]

ATLANTA, August 16, 1889.

We are now having the calm before the storm. August is the month of dull trade. At least it is claimed to be so by the retail dealers. The better class of people in the Southern towns and cities usually spend the month of August either at the seashore or in the mountains; consequently there is less buying now than during any other month. Retail dealers are having a rest. The jobbers just now are on the alert. Most of them from this territory are now in the East buying goods for their fall trade.

The jewelers in Atlanta have made extensive preparations for the coming season's trade. The crops in the South are better than they have been in twenty years, and this fact has given not only the jewelry merchants encouragement, but all branches of trade. The fruit crop has been enormous, while the cotton yield will be one-half million bales larger than ever before. These facts give a healthy tone to business, and inspire confidence in all branches of industry.

One of the largest jobbers in Atlanta said to your representative yesterday: "I expect to double this year the amount of business I did last year. My trade was satisfactory last season, and, judging from the indications, it will be at least one hundred per cent. more this year."

Messrs. J. P. Stevens & Bro. have recently enlarged their store on Whitehall street. It is now one of the largest and best lighted store-rooms in the South. Mr. Stevens is quite an experienced jeweler. He has been travelling in Europe for many months, and his store shows the result of his excellent taste.

A. L. Delkin is now in New York looking after the trade. He will be absent about one month.

Mr. Chas. W. Freeman, of Freeman & Crankshaw, has been spending the summer in the mountains.

Mr. R. N. Scott, of J. R. Watts & Co., has been quite sick. He is better, and will soon be at his place again.

Mr. Robert Freeman, manager of Freeman & Crankshaw's large store, is said to be one of the best all-round jewelers in Atlanta.

T. J. K.

PARIS GOSSIP.

[FROM OUR SPECIAL CORRESPONDENT.]

PARIS, August 10, 1889.

The national fête was this year somewhat more animated than usual, on account of the numerous visitors to Paris. Yet from morning to 5 o'clock in the afternoon frequent showers fell on our capital, but the intrepid inhabitants bore cheerfully against them, never allowing a grumbling word to issue from their lips. A serene evening permitted the splendor of the illuminations to be seen at their best.



BOHEMIAN BONNET—GEMMED.

I chanced to pass near the garden of the Cluny Museum and was particularly struck with the effect it presented. Mediæval statues were adorned with tri-colored glasses lighted up, some crowning the heads and some encircling the necks. Prejudiced people might have considered it as a mockery. They might have said the present is insulting the past, and so on. There was, however, nothing of the kind. The exulting commemorators of the fall of tyranny are very



RUSSIAN CAP—GEMMED.

far from being deficient in good taste, and although they may appear to be, and perhaps are, themselves convinced that they are unbelievers, they deeply reverence all the artistic treasures of France, even those inspired by the most childish superstition.

Revolutionary emblems worn on the 14th of July did not differ essentially from those exhibited by coquettish females on the last 6th

of May, and the tricolor jewelry, completing the effect of costumes *ad hoc*, looked as bewitching as possible.

It might be supposed that the mediæval style applied to jewelry would give it too severe an appearance, and that a lady so adorned could not possibly preserve a cheerful countenance. I am happy to say that such is not the case. Conventional oak tree leaves, ivy leaves, etc., such as you see in stone carving on cathedrals of the middle ages, have been reproduced by jewelers so lightly and so

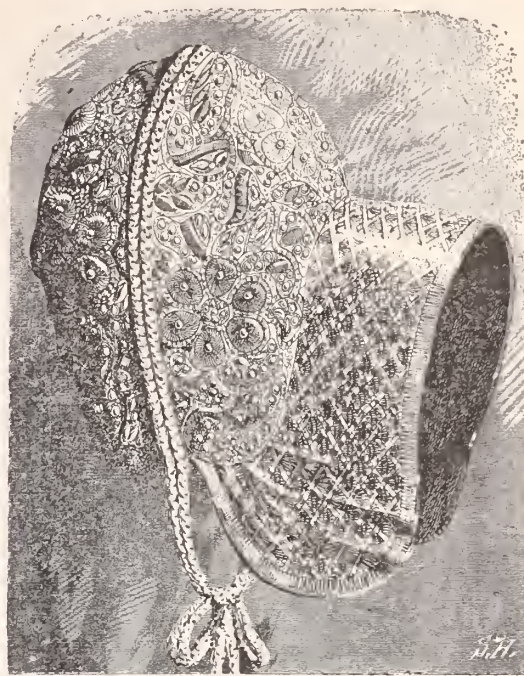

VIENNA BONNET—GEMMED.

tastefully that they have become a most elegant fashion. We are often accused of looking to the past for inspiration, and, no doubt, some of our silversmiths' highest efforts aim at making servile copies of ancient works. Such is not at all the case in the jewelry line. A single hint taken from some details in mediæval architecture has given rise to a new style of adornment never contemplated by the artists of the thirteenth and fourteenth centuries.

A RARE COLLECTION OF JEWELED BONNETS.

The eminent jeweler, Germain Bapst, who is an antiquarian, has, among his numerous collections, a very curious one, which I must, rather briefly, describe to you. I may say, *en passant*, that our intrepid hunter of rare things is but a little more than thirty years

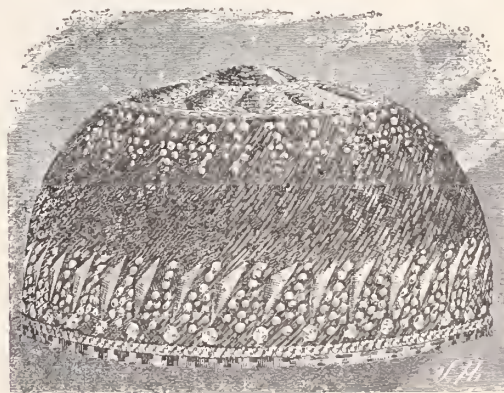

TARTARY CAP—GEMMED WITH PEARLS.

of age, which does not entitle him to be the *doyen* of jewelers, as a correspondent of the London *Times* so liberally called him the other day. A few specimens of old time bonnets seen by M. Bapst in a German museum some time ago, gave him the idea of gathering an important collection of female head-gear of bygone days. The first one of the group I will mention is a pretty Alsatian bonnet in black

velvet, bordered with gold lace, and showing ornaments in the shape of ear corns and other natural products. It is worn on the top of the head and allows the hair to hang at the back. The next one is Russian. It is covered with a wide embroidered material, vaguely reminding us in its outlines of the imperial eagle. It has the shape of a diadem or hieratic tiara, is gemmed and is of a thoroughly Oriental appearance. Some of that kind were worn during the fêtes given on the occasion of Alexander III. coronation.

Then we remark a Saxon one, in the shape of a glory, exhibiting a curious intricacy of ornaments made of silver threads mounted on wire. It mainly consists of coils repeatedly twisted into trefoils, and is adorned with garnets.

The Bohemian bonnet illustrated is of an elaborate design, being all covered with spangles and embroidery. In the center part of the back is an important piece in high relief, consisting of gold threads closely knitted and enlivened with precious stones symmetrically arranged.

The Viennese bonnet, as shown here, is sparkingly adorned, yet it seems thoroughly adapted to the purpose of hiding beauty.

Besides several other peculiar bonnets of France and other countries, Mr. Bapst has gathered some men's head-gears, two of which, a Russian cap and a Tartar one, richly embroidered and studded with pearls, are reproduced here.

A HINT TO SILVERSMITHS.

Among our manufacturers in the silver line, many, as stated already, keep on treading the old paths, thinking, no doubt, it far easier to do so than to open a road across the fields. In that they are mistaken, as the necessity of following a track well delineated, and of stepping into old footmarks must give them very often a clumsy gait. In short, they run the risk of doing imperfectly what has been so well done in bygone years. Why should they not simply like most jewelers, look for inspiration among the works of nature. It takes so very little to make something pretty if you are capable of finding an artistic arrangement. See, for instance, the jardinière reproduced here. It is a silver vessel of a very simple shape, with sprays of flowers showing in various reliefs on a fine granulated background. Fir apples with projecting needles are employed as handles and as feet. Let the whole of it be finished off in a well-shaded oxidized silver, or give it some touches of deadened color opposed to flashes of white, and you will obtain in either case a piece worthy of notice. It is true that this piece cannot stand a bad treatment.



AN INSTRUCTIVE JARDINIÈRE.

It must be most delicately chased and everything has to come up to the mark, since there is no intricacy to confuse the attention of the looker, and no difficulty in finding out the model reproduced in the decoration.

A FINE DIAMOND NECKLACE.

An exquisite diamond necklace, designed by H. Banneville and executed by Duguine for one of the best houses in the Palais-Royal, consists of net work of conventional leaves studded with brilliants. It can be used also as a diadem or worn as a clasp. The first impression it gives is one of elegant originality. Almost every leaf of the conventional foliage seems to turn and to shoot by impulse. What is greatly to be admired in the jewel besides the delicacy of its

treatment, is that so elaborate a piece should be made from such trivial elements. All the separate parts appear to be alike, and yet, through an artistic arrangement which presents them to the eye in different positions, calculated to form together an harmonious ensemble, they give a most charming effect.

ROMANCE OF A GOLD NUGGET.

A gold nugget, 904 millimeters long and weighing 543 grammes, was found recently near Avols, in Ardèche (south of France), by a peasant who was picking up bits of wood. A shepherd, brother of the discoverer, claims that the glittering mineral was the very same



NUGGET OF GOLD FOUND AT AVOLS. (FULL SIZE.)

he a few years ago flung at the head of an unruly goat. He said he never thought of going after it, thinking it valueless. After passing through various hands the nugget reached Paris, where mineralogists examined it. Deep crevices crossing it here and there (as shown in the illustration, which nearly represents the real size) facilitated the study of the inner parts. The metal has been found very compact. Analyzed by Mr. Riche, it proved to contain $\frac{9}{10000}$ gold, $\frac{1}{10000}$ silver and a few particles of oxide of iron. Mr. Descloiseaux, of the Academie des Sciences, noticing some filing marks, supposed it might have belonged to an American mineralogist who had come to the place and lost it, but as the nugget had passed through several jewelers' hands, a different explanation might be offered. Besides, at various periods small gold nuggets have been found in the same neighborhood, which corroborates Agricola's remarks concerning that region of Gaul: *Aurum in Cebennis invenitur in lapillis nigris*. Yet, I do think that a Frenchman of to-day, however proud he might be of the natural wealth of his fatherland, could hardly quote without a smile the *Gallia aurifera* of Cæsar.

SOME REMARKABLE WEDDING GIFTS.

The last remarkable wedding of the season in Paris is that of the Count Allan de Montgomery with Mlle. Double de Saint-Lambert. Let me mention a few of the presents received by the young couple: A diadem of diamonds and pearls from the Duchess de la Rochefoucauld-Doudeauville; a pearl and diamond crescent from the Duchess de la Tremoille; a silver lunch service for traveling use from the Duchess d' Uzès; a trefoil consisting of three enormous pearls bounded with diamonds from the Marchioness de Portes; a bracelet *semaine*, with seven stones, from Mme. de Gallifet; two silver cups in the shape of shells from Princess Murat, etc. The bridegroom presented his bride with a corbeille containing a diamond riviere of three strands, mounted as water drops; a pearl necklace; a diadem in diamonds with a star of the same stones; a shoulder knot (Anne d'Autriche style) made of brilliants; a watch in red enamel surrounded by diamonds, with initials of the same; a scent bottle, with a large-sized ruby as a stopper; a prayer book adorned with hand paintings and bound in Morocco *bleu de roi*, with silver clasps and corners in pierced work, etc.

JASEUR.



The following list of patents is compiled from the records of the United States Patent Office, and specially reported to THE JEWELERS' CIRCULAR.

Issue of July 30, 1889.

Design Patent No. 19,233—BADGE. HENRY M. BETZ, Philadelphia, Pa. Application filed March 23, 1887. Serial No. 232,199. Term of Patent 7 years.

Trade Mark Patent No. 16,874—WATCH MOVEMENTS. AMERICAN WALTHAM WATCH CO., Waltham, Mass. Application filed April 23, 1889. Used since 1864. "The letters and word, 'P. S. Bartlett' stamped or engraved in a semi-circular or curved manner in type or script letters."

407,789—SELF-ADJUSTING EYE-GLASS FRAME. FRED. W. NOLTE, St. Louis, Mo. Filed July 17, 1888. Serial No. 280,162. (Model.) In this invention is combined with the frames the spring-loop nose-pieces, the loop straps secured to the frames and having bifurcations, a bridge piece having connecting stems and angle pins projecting from the stems and fitting in the bifurcations, and the fulcrum clips securing the spring-loop nose-pieces to the frames, whereby the spring-loop fulcrum on the clip secures an increased ratio of expansion and contraction relatively in the movement of the lower portion of the nose-pieces.

407,945—ELECTRIC CLOCK FOR USE IN EXPOSED PLACES. ALFRED SPEER, Passaic, N. J. Filed Sept. 22, 1888. Serial No. 286,115. (No model.)

407,953—PROCESS OF ORNAMENTS GOLD SURFACES. LOUIS JAGIELKY, New York, N. Y. Filed March 3, 1889. Serial No. 302,522. (No model.) This process consists of the following steps successively performed: first, producing a raised design by cutting out the stock around the design; secondly, matting the cut-out ground; thirdly, gilding the entire surface; fourthly, polishing the surface of the raised parts, and, lastly, inserting precious stones into the raised parts and engraving the surface of the raised parts.

407,977—CALENDAR-CLOCK. HARRIS F. WELLS, Friendship, N. Y., administrator of Albert F. Wells, deceased. Filed Jan. 22, 1889. Serial No. 297,107. (No model.) The combination, with a horizontal shaft, of a main actuating wheel attached to the shaft and having thirty-one teeth, pawl mechanism whereby an intermittent rotary motion is imparted to the wheel, a detent engaging with the wheel, a movable detent-releasing frame pivoted to said actuating wheel and consisting of a segmental plate and a lifting foot, a month cylinder provided with an actuating wheel having twelve teeth and operated from the horizontal shaft, one or more stationary pins arranged on the actuating wheel of the month cylinder in the path of the lifting foot, a movable pin arranged on the actuating wheel adjacent to the stationary pin or pins and capable of standing in line with one of said stationary pins when released, a revolving cam bearing against the movable pin, a revolving four-armed wheel connected with the cam and journaled on the actuating wheel of the month cylinder, and a stationary disk having a tooth or projection engaging with the arms or teeth of the four-armed wheel, whereby the latter is turned the distance of a tooth at every revolution of the month cylinder.

407,990—LENS-BLOCKING. JOHN J. BAUSCH, Rochester, N. Y. Filed April 20, 1889. Serial No. 307,970. (No model.) A holder for lenses while grinding the same, consisting of a spherical body with a series of distinct elevated facets, each having its face formed to fit the surface of a corresponding lens.

408,037—WATCHMAKERS' TWEEZERS. JOHN A. MILLER, Cairo, Ill. Filed June 23, 1888. Serial No. 277,986. (No model.) Watchmakers' tweezers, provided with jewel push-tubes, one of which tubes has a flattened side consisting of projecting tubes at the union of the tweezer-arms, these arms being also provided with cuts.

408,055—GLAZIERS' DIAMOND. JOHANN URBANEK, Vienna, Austria-Hungary. Filed June 1, 1888. Serial No. 275,709. (No model.) A glaziers' diamond consisting of a recessed head or block, a handle pivoted within the recess, and two diamonds or cutting-points, one of which is stationary and eccentrically disposed with reference to the pivot of the handle, while the other is adjustably secured to the block.

408,151—ELECTRIC EYE-GLASSES. HERMANN WELCKER, Berlin, Germany. Filed April 25, 1889. Serial No. 308,508. (No model.) In this device is combined, with a sectional frame, insulating plates, a bow spring in metallic connection with one of the frame sections, a nose plate insulated from the bow spring, a nose plate in metallic connection with the bow spring, and the electric conductors.

408,130—NON-MAGNETIC ALLOY. HEINRICH OSTERMANN and CHARLES LACROIX, Geneva, Switzerland, assignors to the Usine Genevoise de Degrossissage d'Or, same place. Filed May 13, 1889. Serial No. 310,634. (No specimens.) This alloy is composed of nickel, chromium, platinum, copper, zinc, lead and tin, in proportion.

408,109—EYE-GLASSES. ROBERT C. KENNEDY, New York, N. Y. Filed March 20, 1889. Serial No. 305,302. (No model.) This improvement combines with the lens frames and the connecting bow spring, of nose pieces pivoted to the lower portions of the lens frames, and automatically-acting springs curved upward and outward from the upper ends of the nose pieces to the upper portions of the lens frames at the points at which the ends of the bow spring are attached.

Issue of August 6, 1889.

Trade Mark No. 16,908—FINGER RINGS. SINNOCK & SHERRILL, New York, N. Y. Application filed June 4, 1889. Used since January 1, 1889. "The representation of a crucible—such as is used for the melting of gold in the manufacture of jewelry."

408,268—EYE-GLASS HOLDER. SIMON R. STIBGEN, Marietta, Pa. Filed April 17, 1889. Serial No. 307,621. (No model.) This eye-glass holder is formed of a single piece of metal and comprises a lateral portion provided with a mouth-piece, a substantially vertical portion having provisions for holding the glass, and an elastic spring joint at the junction of the lateral and vertical portions.

408,308—CLASP FOR NECKLACES. ADAM KELLER, New York, N. Y., assignor to himself and John C. Downing, Newark, N. J. Filed February 16, 1889. Serial No. 305,205. (No model.) In this clasp is combined two barrels fitting within each other and having corresponding holes through each, the outer barrel having a longitudinal slot and the inner barrel a feather to fit into the slot, and a pin on a pivoted arm, and a spring to retain the pin in the corresponding holes through each barrel.

408,498—ENGRAVER'S TOOL. GEORGE A. MASON, Washington, D. C., assignor to John Sellers & Sons, New York, N. Y. Filed May 17, 1889. Serial No. 311,129. (No model.) An engraver's tool consisting of a single piece of steel having one end shaped into a scraper and the other end into a burnisher, and a protecting cap or caps to cover the ends, the cap or caps fitting on co-operating shoulders on the tool.

408,573—STEM WINDING AND SETTING WATCH. EDWARD K. BOYD, Chicago, Ill. Filed January 31, 1889. Serial No. 298,171. (No model.) In a watch movement, the combination, with a handle and a yoke for transmitting motion from the handle to the winding and setting mechanism, the yoke being provided with a tooth of a lever connected to the handle and adapted to engage the tooth to move the yoke to the setting position, and a spring extending from the lever to the yoke, this spring when under tension tending to move the yoke to the winding position.

408,576—JEWELRY TRAY. LOU BURT, Detroit, Mich., assignor to the Burt & Hurlbut Company, same place. Filed May 1, 1889. Serial No. 309,256. (No model.) A jewelry tray consisting of side pieces and a bottom board, this bottom board being slotted in the direction of the grain by slots which lap past each other, whereby it is prevented from warping.

408,665—CLOCK. EDWARD M. MOULTON and MARK MOULTON, Rochester, N. Y.; said Mark Moulton assignor to said Edward M. Moulton. Filed October 4, 1888. Serial No. 287,243. (No model.) In a clock, the combination, with the main wheel and spring, of a sleeve fitting between the sides of the clock frame and provided with a smooth interior, a winding arbor fitted in the sleeve, the ends forming journals resting in the frame and one end projecting, forming a winding stem, and a nut screwing on a beveled screw-thread on one end of the sleeve to clamp the sleeve and arbor together.

Issue of August 13, 1889.

Design Patent No. 19,261—BACK FOR BRUSHES, ETC. HENRY BERRY, Shelton, Conn. Application filed July 17, 1889. Serial No. 317,809. Term of patent 7 years.

Design Patent No. 19,267—CLOCK CASE. EDWARD C. STODDARD, Plymouth, Conn. Application filed July 18, 1889. Serial No. 317,947. Term of patent 7 years.

Trade Mark No. 16,915—COMPOSITION WATCH CASES. THE DUBBER WATCH CASE MANUFACTURING COMPANY, Cincinnati and Canton, Ohio; Newport, Ky.; Chicago, Ill.; New York, N. Y.; Boston, Mass., and San Francisco, Cal. Application filed May 6, 1889. Used since April 25, 1884. "The word 'Silverine.'"

408,725—ASTIGMATIC EYE-PIECE FOR OPTICAL INSTRUMENTS. JOSEPH KORNBUM, JOHN A. BRASHEAR and PARK PAINTER, Allegheny, Pa. Filed March 8, 1889. Serial No. 302,474. (No model.) This improvement has in combination with the eye and object glasses of a telescope or similar optical instrument and the frame carrying the same, an annular lens holder for carrying a secondary astigmatic lens, within which frame the lens is capable of being turned on its axis, and a graduated scale for indicating the angle of astigmatism when the primary and secondary lenses are adjusted in use.

408,830—WATCH CASE. JULES DUBOIS, Brooklyn, N. Y. Filed March 28, 1889. Serial No. 305,081. (No model.) This case has an inwardly beveled ring secured centrally upon the outer face of its cap to form a retaining seat for a photograph, an outer case covering the cap, having an opening therein to register with the seat and encircled by an inwardly-projecting bead or ring, and a covering plate fitting accurately within the opening to close it.

408,903—MUSICAL CLOCK. JOHN SPRANGERS, Kaukauna, Wis. Filed February 19, 1889. Serial No. 300,434. (No model.) In this clock the minute post is provided with a cam, and is combined with a bell crank lever fulcrumed to a bearing on the train frame and arranged to be actuated by the cam, a music box positioned to have its stock lever actuated by the bell crank lever, a finger on the lever arranged to come in the path of the music box fan when the stop lever is actuated, and a spring cut-off arranged on the music box to interpose itself between the stop lever and the adjacent gear wheel at the same instant that the finger comes into position with relation to the fan.

408,935—CLIP FOR SILVERWARE CASES. HENRY SIEBERT and WILLIAM SIEBERT, Bayonne, N. J. Filed March 11, 1889. Serial No. 310,390. (No model.) In this device is combined with a block strips formed with long and short legs, the long legs resting against the side faces of the block, and the short legs overlapping the upper face of the block, a clamping bolt, a nut that is engaged by the bolt, and a washer through which the bolt passes.

408,956—CLOCK PENDULUM. WALTER D. DAVIES, Brooklyn, N. Y. Filed March 27, 1889. Serial No. 304,983. (Model.) A pendulum having a rotary spindle or arbor supported in it, with its axis at right angles to the balance of oscillation of the pendulum, a figure or body mounted on this spindle or arbor, a ratchet wheel fast on the spindle or arbor, and a pawl pivoted to the pendulum and engaging with the ratchet wheel.

409,132—BUTTON OR BADGE. STEPHEN C. WILCOX, Dubuque, Iowa, assignor of one-half to Alonzo V. Richards. Filed August 18, 1887. Renewed July 9, 1889. Serial No. 316,994. (No model.) The inventor here combines a formed with an opening and provided with a rim having inwardly bent lips, a base plate formed with notches adapted to pass over

these lips, and having its margin gradually increased in thickness from the notches in one direction, and a layer of colored material lying between the base plate and the inner face of the cap.

409,150—TIMEPIECE ESCAPEMENT. ALEXANDER KAISER, Berlin, Germany, assignor to Ludwig Marckwald, same place. Filed October 9, 1888. Serial No. 287,651. (No model.) Patented in Germany May 19, 1888, No. 46,989; in France August 7, 1888, No. 192,294; in Belgium September 12, 1888, No. 83,243; and in Switzerland November 21, 1888, No. 175. In an escapement for watches and clocks, the combination with an escapement wheel, of a cylinder having a notch for receiving the teeth of the escapement wheel, a balance wheel provided with a hub having parts cut away, pins on the balance wheel, projections on the cylinder, on which projections the pins on the balance wheel can act, and arms or projections on the cylinder, which arms or projections can come in contact with the hub of the balance wheel.

Issue of August 20, 1889.

Design Patent No. 19,276—HANDLE FOR TABLE WARE. ROBERT HENRY KLINGEL, Bridgeport, Conn., assignor to the Holm's & Edwards Silver Company, same place. Application filed July 24, 1889. Serial No. 318,556. Term of patent 14 years.

Design Patent No. 19,277 and 19,278—FOUNTAIN PEN OR PENCIL HOLDER. EDWARD TODD, JR., New York, N. Y., assignor to Edward Todd & Co., same place. Applications filed July 10, 1889. Serial Nos. 317,053 and 317,054. Term of patents 7 years.

Design Patent No. 19,269 and 19,270—CLOCK CASE. GEORGE WARD BIDWELL, New Haven, Conn. Applications filed May 10, 1889. Serial Nos. 310,347 and 310,348. Term of patents 7 years.

Design Patent No. 19,271—BADGE. JOSEPH K. DAVISON, Philadelphia, Pa. Application filed June 11, 1889. Serial No. 313,929. Term of patent 14 years.

409,255—KEY HOLDER. CHARLES E. VAN NORMAN, Waltham, Mass. Filed January 24, 1889. Serial No. 297,341. (No model.) This key holder consists of a chain with a locking device, having an eye attached to one end of the chain, a cross bar or lateral extension and a spring bail or hook, adapted to be locked to the opposite end of the chain.

409,267—CANE OR PARASOL WATCH. JAMES W. ALLEN, St. Louis, Mo. Filed August 20, 1888. Serial No. 283,239. (No model.) The combination, in a cane or parasol watch, of the watch movement, the watch movement holder and the cane or parasol stick, the cane or stick at its end being attached to a part which is journaled in the watch movement holder, and in engagement with the watch winding mechanism for the purpose of effecting the winding of the watch movement.

in the walls of *d*. The hole *g* is larger than the pin *f*, and thus allows play of *e* to *c*. The pipe and its clutch member *c* are free to rotate axially in the handle excepting as the member *e* is forced down into *c*, and thus by its friction therein restrains such rotation more or less, as may be desired.

In letting down the watch spring, the pipe is placed upon the post or arbor, pressure is applied to the clutch to hold the pipe from rota-

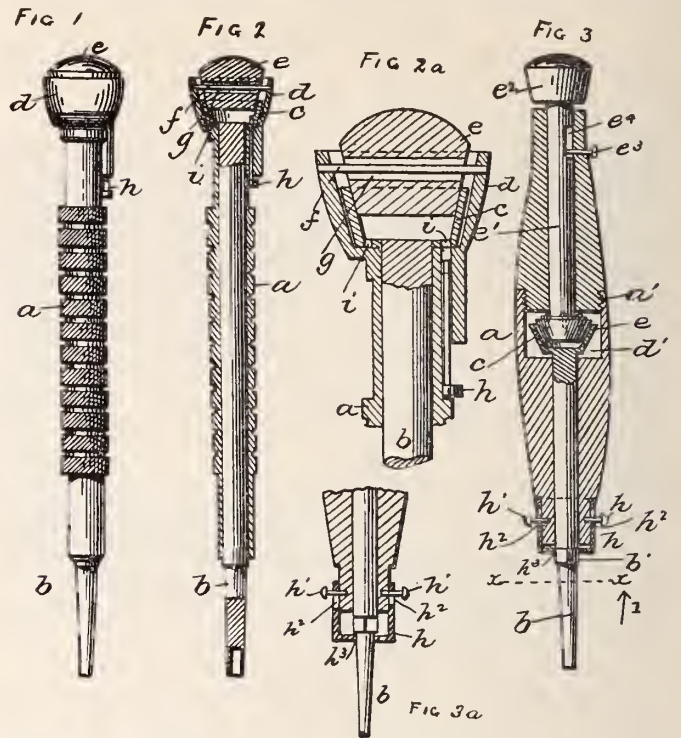

New Watch and Clock Key.

MARTIN BOCK, of Hazleton, Pa., has had recently patented an improved key for timepieces which is novel in its construction and useful in application. Its object is to unwind or wind the mainspring of a watch or clock, and consists, firstly, of a freely-rotating pipe to engage the post or arbor of the mainspring, combined with a friction-clutch by which the rotation of the pipe may be regulated, so as to let down the spring gradually and easily without danger of breaking and without accident or injury to the workman; secondly, of a detent or locking device for such pipe, whereby its rotation may be permanently arrested for any purpose in letting down the spring, and also for winding.

In detail, with reference to the accompanying diagrams, in which like parts are similarly designated, fig. 1 represents a side elevation and fig. 2 a longitudinal section of the key with the parts locked; fig. 2a an enlarged vertical section with the parts unlocked; fig. 3 is a longitudinal section of another form with the parts unlocked; fig. 3a a detail section with the detent unlocked; fig. 4 a section taken in the plane of line *x x*, fig. 3, and looking in the direction of the arrow 1; fig. 5 is a longitudinal section of the clock-key with parts unlocked; fig. 5a is a detail section with the detent unlocked; fig. 6 is a section taken in the plane of line *y y*, fig. 5, and looking in the direction of arrow 2; and fig. 7 is a longitudinal section of another modification, the parts being locked, while fig. 7a a detail section with the detent unlocked.

The form of the handle, as well as that of the clutch and pipe, is susceptible to many modifications.

The handle *a* is tubular, and within it is arranged the pipe *b* having at one end one member, *c*, of the clutch, which may be cup-shaped or tapering outwardly, with the head *d* of the handle shaped correspondingly to it. The other member, *e*, may be a block of hard wood, shaped to enter *c* and more or less firmly to engage it, according to the pressure exerted. The member *e* is loosely arranged in *d* upon a pin or cross-bar, *f*, fixed loosely in a hole, *g*, in *e*, and fixed

tion, the click of the spring-barrel ratchet is released, and then the pressure is decreased sufficiently to permit the spring to unwind gradually and easily, the pipe rotating correspondingly under the action and control of the friction clutch.

A heavier and more substantial tool may be needed for clock-work, and such is shown in figs 5 and 6. The handle *a* is rather more bulky, but otherwise may be substantially as in the examples

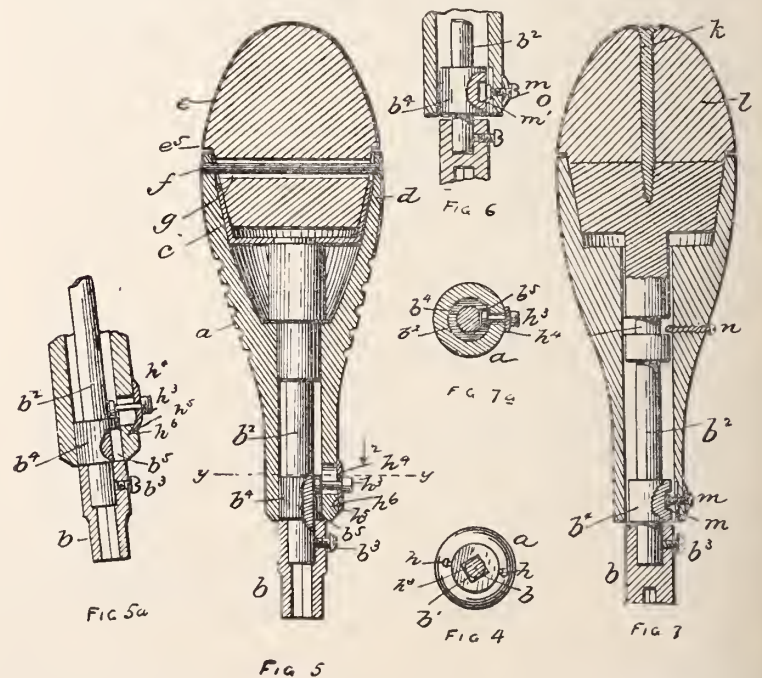

already described. In fig. 5 the cavity in the handle below the member *c* may be filled up with wood to form a support, or the stem may be shouldered, as shown, for a like purpose.

In fig. 7 the handle is shown as forming the member *c* of the clutch, and in this case wood or metal may be used for such handle. The stem *b*² is provided with the member *e*, and if the handle be of wood then, preferably, this member will be of metal.

Fashions in Jewelry

A Lady's Rambles Among the Jewelers and Dealers in Art Glass and Keramics.

THERE is a decided novelty in necklaces. This is formed with the flexible stem of a flower and its foliage in diamonds and precious stones. The gold stem encircles the neck while the multicolor part serves as a pendant or clasp. A charming necklet of this description had for its pendant a spray of diamond grape leaves with amethyst berries.

* * * * *

THE present style of dress bodice favors the wearing of neck ornaments. The consequence is an increased popularity of gold beads and necklaces of every description. For day wear are tiny little neck chains with daisy or mignonette pendants enameled in natural colors.

* * * * *

THE engagement or invisible locket, as it is also called, is worn from a light neck chain and falls out of sight underneath the bodice. These lockets are thin, flat and closed on both sides. It hardly needs be told that they contain a miniature and that the smooth case is engraved or etched with the giver's name and the date of the engagement.

* * * * *

THE Victoria, a modification of the Queen chain, has been well received and promises to find increased favor. It is short and of light workmanship, with a bar at one end and a ball or charm at the other, the swivel for the watch being on a small drop chain. The watch is thrust inside the bodice the same as with the Queen; the bar in the button hole, however, keeps it from pulling on the chain.

* * * * *

LADIES are wearing fancy vest chains. These are sometimes fastened with a bar and sometimes with a pin, to the bodice.

* * * * *

SCARF rings for men have been revived and are out in a variety of designs, some of the most attractive of which are enameled and set with small gems.

* * * * *

A BROOCH deserving mention is made of dead gold, inlaid with a cross of light blue enamel, and has a gray pearl in the center.

* * * * *

LONG purses of silver wire net work, with a ring in the center, made after the style of old time silk knitted ones, are a feature among purses.

* * * * *

DECORATIVE hair pins with crooked gold prongs, are quite new. The diamond heads represent a leaf, a flower or other design.

* * * * *

ALTHOUGH the Eiffel Tower does not receive as much attention from the American jeweler as it appears to do among the French it is represented in some of the trinkets made on this side. It is etched or traced in enamel on gold sleeve buttons, and also serves as a watch charm.

* * * * *

THE styles of most of the jewelry now worn show a decided tendency to those of the Renaissance with its combination of precious stones and colored enamels set in chased, engraved or filigree gold and silver.

A PENDANT worthy of description shows a Renaissance frame of enameled leaves terminating with pearls, and the center a miniature bust of silver surrounded by a circle of pearls.

* * * * *

A CROSS of oxidized silver with garnets set in gold at the four ends, a large garnet surrounded by pearls furnishing the center, furnishes a unique pendant.

* * * * *

IN gold jewelry, the Roman finish is a popular one.

* * * * *

YOUNG men show a preference for the Dickens or double pocket chain, especially when a seal cut intaglio drops from the center.

* * * * *

A DIAMOND necklace set in a late fashion—that is, the setting quite invisible—and consisting of two rows of graduated diamonds, the largest being at the lower part of the necklace, resembles two circles of brilliant lights with nothing to support them.

* * * * *

GOLD curb jewelry is in high favor. There are stiff curb bracelets and flexible curb bracelets, platinum and gold curb bracelets, and brooches and gold curb rings.

* * * * *

SOME of the very newest bracelets are decidedly massive in effect and present a striking contrast to the dainty gold wire ones which are equally fashionable.

* * * * *

THE desire manifested by the fair sex for miniature paintings set as brooches amounts to almost a craze. These paintings are imported and leading manufacturers claim that they have difficulty in mounting them fast enough to supply the demand.

* * * * *

A NOVELTY in gold curb chains has been gained by flattening the rounded edges of the curbs. The result is decidedly effective.

* * * * *

NARROW ribbon watch fobs are provided for evening wear with gold swivel and slide. The ribbon employed is narrow.

* * * * *

A CHARMING brooch of circular form is carried out in filigree gold, dotted with clusters of small sapphires and a diamond in the center.

* * * * *

SLEEVE buttons for men run somewhat larger in size.

* * * * *

OF the making of watch charms, there appears no end. One sees little gold vinaigrettes, gold purses, baskets of flowers, fans open and shut, perforated balls, and Eiffel Towers dangling from the Queen and Victoria chains.

* * * * *

GOLD plaques with plain bright surfaces figure as watch charms, and when they find owners are engraved with name and date.

* * * * *

SOME of the jewelers are offering what they term "Fiancée" jewelry, which includes curb bracelets fastening with a padlock and key, brooches that outline two hearts with gems, diamond orange blossom brooches, lucky moonstone bracelets and the engagement lockets.

* * * * *

A BROAD band bracelet, showing a renaissance design, partly chased and partly engraved, is a very effective ornament.

* * * * *

MINIATURE watches are now worn in the large heavy curb bracelets; these also appear on some of the wire bracelets.

THE beautiful things in silverware are not all on exhibition at the great show in Paris. There is a fine stock at home ready for the fall trade.

* *

* *

* *

SILVERSMITHS in preparing their new goods have not been limited in designs to any school, period or country, hence their productions afford an exceedingly wide range of selection.

* *

* *

* *

IN the matter of tea and dinner service, each lady may choose what suits her best, with every confidence that she will be in the fashion. If she wants massive pieces with pronounced oriental decoration, she will select a service in East Indian style; if something decidedly unique, her selection may be a Japanese set, decorated with Japanese landscapes artistically etched and tinted; or her service may be in Queen Anne style, or purely American. Does she like the *repoussé* work, she will find what she wants marvellously well done, or with equal propriety she may select satin finished work, or bright finish or the surface of the pieces may be etched, chased or engraved.

* *

* *

* *

JUDGING from what is to be seen in the shops, the coming season will see a continued demand for silverware simulating that made in good Queen Anne's time. There are also examples of the oval shapes, spiral flutings and chased edgings of George III. period.

* *

* *

* *

DESSERT knives with carved ivory handles and chased silver ferules, have blades engraved with fruit designs. Similar knives for fish, show piscatory designs.

* *

* *

* *

BOUQUET holders for ladies and boutonniere holders for men are out in gold and silver. These are designed so as to be connected by the flowers they hold.

* *

* *

* *

EACH season a few novelties appear in the way of jewelry cases and the present is no exception; although velvet cases, small and compact, with soft linings, are the sort generally preferred for fine goods.

* *

* *

* *

CELLULOID cases which have been more or less made for three years afford some novelties. Very artistic ones seen were delicately tinted, etched in Japanese effects and otherwise decorated with applied ornaments of oxidized silver or bronzes. These cases are lined with satin and afford a pleasing contrast with the velvet ones. The applied ornaments are imported from Japan and represent in many cases flies and other insects.

* *

* *

* *

IN silverware, there are all sorts of dainty souvenirs such as glove buttoners, stamp boxes, envelope openers and the like, which are hid in fancy baskets of bon-bons, when the sender is on hardly sufficient terms of intimacy with the fair lady to openly offer the trinket.

* *

* *

* *

APROPOS of confections, there are some charming little bon-bon baskets of woven silverware, with fancy tongs for handling the sweetmeats.

* *

* *

* *

A QUITE new idea in traveling bags is expressed in a bag with a spring stand holding all the silver appointments and fixed to the center of the bag, but removable at will and adapted for standing upright on a dressing table.

* *

* *

* *

NUMBERED with fashionable knick-knacks, are card and letter cases of lizard skin, with silver mounts.

ONE of the prettiest among the Eiffel Tower ornaments is a candlestick produced in filigree silver.

* *

* *

* *

LITTLE shopping bags of leather or velvet, with silver clasps and chatelaine, are popular. Many of these have the initial of the wearer wrought in silver on one side.

* *

* *

* *

A DAINY photograph frame is of white enamel wood with a wide trellis designed in silver wire all around it. This trellis design, by the by, is something of a novelty and has been adapted to a number of knick-knacks.

* *

* *

* *

CIGARETTE holders of amber are mounted with little acorn-shaped pipes in gold.

* *

* *

* *

THERE are eye-glass guards of delicate gold chain, made to wear around the neck and held in place with a slide. These are thought to be an improvement on the old kinds.

* *

* *

* *

A NOVELTY in silver is called the scuttle sugar basin and is an exact copy, so far as form is concerned, of a scuttle.

* *

* *

* *

SILVER trays of small dimensions and of shell form are used as bon-bon plates.

* *

* *

* *

THE statement was recently made in a New York daily that men are wearing bracelets. If leading manufacturers and jewelers are authority, this is a mistake. The fad is not known outside of the extreme borders of Dudedom, which men do not cross.

* *

* *

* *

THE very latest in parasols are those with a fan inserted in the hollow silver handle.

* *

* *

* *

THE fashion is all the while growing for such fancy jewelry as is expressed in diamond sprays, rivieres and other ornaments suitable for trimming the front of a low bodice. To meet the demand this fancy conceives three sprays of diamond holly leaves and ruby berries; gold acorns and oak leaves; wild roses and their foliage and similar devices.

* *

* *

* *

MOST of the long jeweled sprays designed to wear on the dress bodice or in the hair, can be divided at will into two or three pieces which may serve as brooches, settings on bracelets, or as pendants.

* *

* *

* *

A FAVORITE form of necklace appears to be a strand of gems about the neck with larger gems hanging pendant in front. This same idea is carried out in gold neck chains which have rows of enameled flowers or gems suspending from them, after the fashion of a fringe.

* *

* *

* *

GOLD beads are more worn than ever.

* *

* *

* *

CHATELAINES continue in style.

* *

* *

* *

DECORATIVE combs still find favor and are frequently costly

affairs with their exceedingly fine workmanship and gem-set tops.

* * * * *

ENAMELED jewelry, which is now made in great perfection, appears to be as popular as ever.

* * * * *

THERE are some very attractive round brooches in colored enamels, with gem-set centers.

Art Glass and Ceramics.

BEAUTIFULLY decorated gilt vases of Crown Derby attract attention wherever seen, and afford attractive objects in the jewelry stores.

* * * * *

VERY beautiful are the dessert services of Doulton decorated with raised designs in gold and platinum.

* * * * *

A DECORATIVE vase in Royal Worcester is colored in imitation of old ivory and has pierced handles. The designs on the panels represent a peacock worked out in raised gold and surrounded by a floral arabesque scroll in gold and metallic colors.

* * * * *

QUITE new among ink stands is a Dresden china one in the form of a Louis XVI. sofa; the cut glass ink wells on either end are silver mounted.

* * * * *

AN attractive feature in some of the show windows are the vases and mantel ornaments of pierced and raised work on ivory tinted Worcester porcelain. The same may be said for the vases showing an application of gold and metallic tints.

* * * * *

CUT glass claret jugs have silver tops which are attached to the handle of the jug by means of a silver chain.

* * * * *

VERY beautiful effects are now produced on crystal glass and choice ceramics by the electro deposit process. This artistic combination of silver and glass and silver and fine porcelains is especially happy in toilet articles, vases and perfume bottles.

* * * * *

A PRETTY dinner table ornament just received from the other side is in Bohemian ware, and represents a Jersey lily. The shape, size and color—soft garnetish shading into cream—are accurately reproduced. This piece is designed simply for decoration, but it answers its purpose well.

* * * * *

IN after-dinner sets, several charming novelties are being displayed by the importers. Some that attracted my attention especially were in Carlsbad china with fluted or *canellée* surface and floral, tinted and gold ornamentations. Single moustache cups and saucers in the same ware and design are new and will satisfy the fastidious at their breakfast coffee.

* * * * *

CRYSTAL spring glass, in flower vases of various designs, an importation from Bohemia, is one of the most recent novelties. A series of rounded flutings, starting from the rim of the neck, which in some cases is itself festooned, and continuing to the bottom create a handsome effect. All the pieces have this characteristic.

A MARVELLOUS piece of Doulton pottery is a vase representing a large rhinoceros tusk and having a dragon for the handle. It stands about fifteen inches in height, and rests on its broad end. The shape is last season's but the decoration is entirely new. The handle is the noticeable feature. The dragon which is in gold, trails its tail about the base of the vase, and its head with mouth agape stands out in full relief at the neck. One would think that the combination of the tusk and dragon would create a feeling of repulse on the part of the observer, but the effect is contrary.

* * * * *

MANY new and beautiful shapes in Doulton with tapestry ornamentations are on exhibition at the various importers.

* * * * *

IN Royal Worcester, decorations this year are about the same as last season's, but numerous new shapes are displayed, especially in plates, some of which have festooned edges and others are shell-designed. These are particularly pretty.

* * * * *

ATTRACTIVE and rich in design are some new shapes in floor vases of George Jones Crescent china and Foleyian ware.

* * * * *

PETITE and pretty are several new creams, sugars, and fancy little teapots in George Jones Crescent china, with natural flower designs. The clouded gold of the edges standing into the white is a charming effect. These little beauties will surely satisfy any lady of taste.

* * * * *

CHINA decoration still being a popular fad in polite circles jewelers are constantly being called upon for white china novelties for decoration. A large number of such, in fancy cups and saucers, moustache cups, creams, bread and butter plates, smoking sets, etc., have just been received.

* * * * *

CARLSBAD ivory ware resembles Royal Worcester in shapes more and more each season. A line of small ewers seen was decorated with beautiful little violets and leaves in natural colors.

* * * * *

CARLSBAD ivory ware novelties in shell and basket forms are most charming.

* * * * *

VERY rich and attractive are new jardinières of Bonn faience with gold effects.

* * * * *

STYLISH and pretty are the new designs in Pointons pottery.

* * * * *

THE new clematis floral designs and combinations in the Carlsbad clematis ware, are exquisitely beautiful and truthful. Vases, jugs, and fancy pieces, in this ware are to be seen in many new shapes and decorations.

* * * * *

NEW trays, ice cream sets, celery trays, etc., in Parisian designed fine cut glass are being displayed in many new patterns.

* * * * *

BEAUTIFUL hock glasses in exquisite combinations of colors—blue and red, shading into purple, ruby shading into yellow, producing the colored effect of a flame, blue and yellow shading together and looking like changeable silk, etc.—have just been produced. Some

are plain, others fine cut, and others engraved charmingly in rock crystal style.

* * * * *

IN cut glass, numerous new patterns are to be seen. The writer saw a punch bowl, large in size, cut with prisms and fans. The execution of this piece was so perfect, that the ideal—that it should resemble the diamond in color, or rather lack of any color, and brilliancy—was reached. No flaw or scratch or color marred its perfection.

* * * * *

TENNIS players in white and gold, represented in bisque figures, are new and pretty and will please the lover of the polite game.

* * * * *

WATER bottles or carriers of fine cut glass, are now *recherché* for use on the dining table. They can be had in a variety of designs, and the most exacting can be accommodated. ELSIE BEE.

Lathes and Lathe Work.

BY THE MODEL WATCHMAKER.

IT IS well before we take up the subject of first-class gear cutting engines, to understand the principles involved in gears and gear cutting. The problem of the teeth of gear wheels involves many factors; some are evident at sight, while others are obscure and only present themselves after a great deal of thought and study. The simplest, and at the same time most perfect gear wheels, are those which run by friction, and can be defined as wheels with innumerable teeth, these teeth being infinitesimally small. Practically such wheels would be uncertain in their action, and incapable of transmitting any power. The first idea which would occur to the mechanic to remedy these defects would be to attach points, or pins to one wheel which would engage and enter into corresponding recesses in the companion wheel.

As the subject received more and more attention, mathematicians of high attainments took the problem in hand, and the result was the evolution of the epicycloidal tooth, which form of tooth stands permanent to-day for all wheels containing less than ten teeth. Few teeth cut for clock or watch work are more than an approximation of the epicycloidal form. I will give first the principles on which such curves are formed, and then give the methods by which this curve is easily approximated for most requirements. Before we proceed to consider the form of the epicycloidal curve we will give some attention to what is known as angular velocities. For instance we take three perfect wheels whose peripheries touch each other, as shown by the circles *A*, *B* and *C* in the cut. Now if the wheels *A* and *B* were exactly of the same diameter, their angular velocities would be the same, that is, if *A* turned through an arc of one degree or ten degrees, *B* would turn the same. But *B*, having half the diameter of *C*, would have double the angular velocity. Now in order to get fine practical results from gear wheels the form of teeth must be such as to maintain such relative velocities. To illustrate, suppose we have two wheels whose diameters are to each other as five to one. Now the action of these wheels is represented by the two levers *e f*. If the longer lever *e* moves through an angle of 5 degrees, the shorter lever *f* should have moved through 25 degrees, but the reader will see at a glance by the diagram, fig. 2, that the shorter lever *f* would be restrained or held back, consequently the motion would be irregular and jerky. What the epicycloidal curve accomplishes is to define the form of the teeth so they will

impart a uniform angular motion. Of course, this statement has not been proven yet, and we must now make the demonstration. Perhaps some of my readers would like to have the word epicycloid defined. I will first define the word cycloid. It means a curve produced by rolling a circle on a straight line. As for instance in fig. 3 if we had a wheel *D*, and a fine tracing point placed in the periphery and this point rested against a wall or tablet, the wheel *D* being rolled to the right, the tracing point at *g* would describe the line *h h*. Here the curve *h h* would be a cycloid. If again we should roll the wheel *D* on a circle, as shown at *F*, fig. 4, the tracing point would describe the curve *i i* which would be epicycloidal. Again we will place our wheel *D* on the inside of a circle and roll it, in this case we produce a hypocloid, as shown at *J J*, fig. 6. Now in producing teeth for gear wheels we must shape the tooth outside the pitch line on a curve formed by rolling our generating circle *D* on the outside of our pitch line; and the portion of the tooth (called flanks) inside the pitch line. At fig. 7 is shown a curious hypocloid produced by rolling the generating circle *D* inside a circle twice its diameter. There are several methods for delineating the epicycloidal curve; one of the most practical consists of using circles several times as large as the work to be ultimately produced. To illustrate: suppose two circles are very carefully turned out of metal in the proper relative proportion of size to each other as shown at *D F*, fig. 4. If now we should wrap a thin ribbon of steel partially around them (*D F*) and secure the ends at *l m*; and we arranged so the ribbon *l m* that it was kept taut and *D* rolled on *F*, then tracing point *g* would describe the curve *i i*

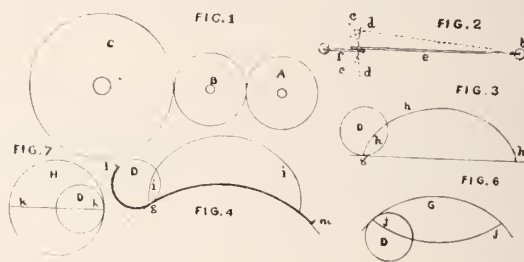

almost perfectly. It would be theoretically a little incorrect, but for practical purposes it would be all right.

In the definitions just given, I have avoided all mathematical formulæ so tiresome to the general reader, and endeavored to come to simple and plain explanations of the principles involved. In my next communication I will explain how to delineate an epicycloidal curve geometrically, and then explain in detail how to construct teeth embodying the principle and form of the epicycloid. Before doing so I must beg the reader's indulgence for a slight talk on what most watchmakers term "depthing."

This seems to be a subject on which most all workmen have an idea they have profound knowledge, and still not one in a hundred is capable of calculating the proper relative pitch diameters of a wheel and pinion of $7\frac{1}{2}$ to 1, even after the distance between the centers of the two holes are given. And yet this is precisely what the workman should know, and just what I shall endeavor to explain to my readers. It is not a difficult problem; it does not in fact involve as many figures, or require any deeper mathematics, than are necessary to ascertain the amount due on a note of hand for \$75, which has been running for 10 months at 7 per cent. interest. Let the reader acquire a correct knowledge of the proper form of teeth and pinion leaves, and then assure himself of the fact that the two wheels, or wheel and pinion, are of the correct size to secure the demanded relative angular velocities and the problem of depths is solved. I can conscientiously assure my readers it will pay them for the short time involved to master all that is necessary to know.

Copyrighted 1888 by Charles A. Bucklin.

Mechanical Ocular Defects.

Their Nature, Cause, Correction and Relations to Functional Nervous Diseases.

EDITED BY C. A. BUCKLIN, A. M., M. D., NEW YORK.

[The aim of the author is to produce a clear and thoroughly practical course of instruction on the subject of "mechanical ocular defects," which is entirely void of useless technicalities and within the easy comprehension of every thinking student, without his having had any previous technical or mathematical education.]

THE FRAMING OF LENSES.

THIS is an intensely practical subject and should be thoroughly understood. The truth of the matter is, the subject is the least thoroughly understood of any in the whole chapter of practical optics as applied to the selection of correction lenses. I frequently meet practical men who have been in the retail optical trade for twenty or more years who gaze with astonishment upon some experiment which demonstrates the absolute necessity of careful framing. They freely acknowledge that they never had suspected that so many difficulties could be caused by the faulty relative position of the lenses produced by an improper frame. Simple spherical lenses are owing to this fact, much more difficult to handle correctly than cylindrical lenses.

The majority of applications I receive from students commence by stating that they know all about spherical lenses and their adjustment for the various ocular defects requiring their use, but they now wish to learn the nature of some of the complicated subjects, such as astigmatism and its correction by cylindrical lenses, etc. Astigmatism and its correction is a simple subject, while the use of spherical lenses for the correction of *hyperopia*, *myopia* and *presbyopia* presents unending complications which the most experienced experts have great difficulty in overcoming. Nothing convinces me more thoroughly that an individual knows absolutely nothing about optics as applied to the eye than his statement that he knows all about the subject excepting *astigmatism* and the *muscles*. The mere fact that he does not understand the ocular muscles demonstrates that he does not understand the use of spherical lenses as he should, for in the muscles lie all the difficulties which complicate the use of spherical lenses.

There are few men with so bright a mind that they can learn how to use simple spherical lenses properly without having had thorough instruction on the subject.

Every pair of lenses of considerable strength which are exactly suited to the eyes of an individual, may be so framed that the party cannot wear them without experiencing immediate discomfort.

The requirements of distinct binocular are very complicated. It is necessary that the ciliary muscle of each eye and the twelve muscles which direct the visual lines of the eyes in binocular fixation shall act in such perfect harmony that both eyes are easily directed at any given object, and easily accommodated for this object without bringing any undue strain on any muscle involved in this complicated action. The relations existing between accommodation and convergence being very exact, they are consequently easily disturbed. The individual with a given degree of convergence has learned to use a given amount of accommodation; the introduction of lenses disturbs these existing relations. When the lenses are properly introduced the disturbance arising from this cause will be less than the disturbance of accommodation which existed without the lenses. In many cases the introduction of the lenses in an improper manner produces a greater muscular disturbance than the accommodative disturbance that formerly existed without the lenses, although the lenses have been properly selected.

Convex lenses act from the center as prisms, the base being at the center of the lens. Concave lenses act as prisms, the base being at

the circumference of the lens. These lenses cease to act as prisms when the line of vision passes exactly through the center of the lens. It will thus be seen that they may be deprived of the prismatic effect they produce by placing the centers so that the line of vision for each eye passes directly through the center of the lens when they are used. The lenses may be placed so that the prismatic effects assist given muscles, or they may be so placed that they increase the work necessary for given muscles which were already taxed to their utmost capacity. This is the cause of the trouble experienced by most persons who first attempt to wear convex lenses, the relations between the fixation of both eyes and the accommodation being disturbed in any case, and being disturbed to a very annoying degree when the centers of the lenses are outside of the line of vision. They then act as prisms, antagonizing the internal muscles in their efforts to produce convergence. When the center of one lens stands higher than that of the other the most annoying weak vision is produced when the vertical muscles are normally balanced. Occasionally individuals having a weak vertical muscle wear their glasses with a most decided tilt, thus favoring with the vertical prismatic effect of both lenses the disabled muscle.

Convex glasses for reading require the distance between their centers to be much less than the distance between the pupils of the eyes. The proper position for lenses in the frames can only be determined by experimental trials on each individual. The American adjustable trial frame is most valuable for this purpose.

Many persons cannot use the same frames for distant vision and reading, owing to a peculiarity of the nose and face. Frames which are perfect for reading set too low for distant vision and *vice versa*. A selection of sample frames from the various manufacturers should be in the possession of those who deal in optical goods, for there is no way so perfect in determining what kind of a frame to order as an experimental trial with the frame. The catalogue number of the manufacturer being attached to the sample, you simply have to give the number, pupil distance, height of nose, and you will obtain the frame desired. Occasionally it is necessary to please an individual by ordering cylindrical lenses in eye-glass frames. Instruct the individual to take hold of each end of the frame selected and place it where he finds it most comfortable. Then carefully measure with delicate dividers the distance between the spring parts and lay this distance on a match. Carefully cut the match, being sure that both marks from the dividers are cut away. Enclose this frame with the piece of match to the manufacturer, indicating the points on the frame between which the match must be placed.

Your prescription will then be filled with approximate correctness. When the glasses are returned let the patient place them on his nose. Cover one eye with a card and slightly tilt the frame up and down to determine if the axis is in the best possible position. Repeat this experiment on the other eye. Any slight error in the position of the axis may be corrected by adjusting the frame. To finally test the correctness of both axes, call the patient's attention to a card at twelve feet distance; if it appears perfectly square the axes are correct; if not, the axis of one or both cylinders is wrong or the cylinders are too strong. Distant square objects should not appear out of square.

All cylindrical lenses ordered should be tested when they are returned from the manufacturer in the above manner. The correctness of the axes of cylinders should always be tested with a square card before they are ordered.

A frequent trouble which is unrecognized and makes selected lenses unsatisfactory, is their being out of center. It is not an unfrequent thing to find the optical center of a lens $\frac{1}{4}$ of an inch away from the center of the lens. This defect can be detected by looking squarely through the center of the lens at two lines which cross each other at right angles. When the lens is centered the portions of the lines seen through and outside of the lens are all continuous. When the lens is not centered the amount and direc-

tion it must be moved to make the lines continuous, locates the position of the optical center of the lens.

NOTE.—The student with the above text before him and a small collection of assorted lenses to practice with, will become very expert in a short space of time in analyzing lenses, and will also become very familiar with the cylindrical and prismatic effects which can be produced by changing the position of various spherical lenses.

All the lenses and combinations of lenses which we have thus far considered exist in human eyes. The defect is of an opposite value from the lens required to correct it. We will next consider the eye as an optical instrument, and the optical defects which result from its deformities and infirmities.



[THE CIRCULAR is not responsible for the opinions or statements of contributors, but is willing to accord space to all who desire to write on subjects of interest to the jewelry trade. All communications must be accompanied by a responsible name as a guarantee of good faith. No attention will be paid to anonymous letters. Correspondence solicited.]

Cazenovia, July 29, 1889.

DO WE MAKE WATCHMAKERS TOO FAST?

To the Editor of the Jewelers' Circular:

A great detriment to the watchmaking trade to-day is the ease with which a young man may set up in business for himself. Three months in a jewelry store, a small stock of watches and jewelry, a few clocks, a glib tongue and lots of cheek are all that is necessary these days for a start in business. Apparently the majority of the watch-carrying public consider price before the ability of the workman to make repairs on their timepieces, and because a workman who has served long years of apprenticeship wants fair pay for good work, they take their watches to the "new fellow," never stopping to inquire as to his skill or experience, and when he has succeeded in utterly demoralizing their watches they come to the old workman and expect him to repair the damage done by the botch. Even then they grumble if the price is higher than that demanded by inexperience. I have had watches brought to me with the ratchet cover soldered to the bridge, scape wheel soldered to the pinion, roller plate soldered to the staff, brass roller jewels, plate and bridge jewels set in soft solder or cement, bits of mainspring for cap jewels, mainsprings riveted together and—but I forbear; there is no use trying to enumerate the wonderful triumphs of inventive skill exhibited by these phenomenal workmen, who, if you believe their friends, were evidently foreordained and predestined to be skilled mechanics without any previous instruction or preparation. No young man who wants to make a success in the trade of horology should start in business for himself without serving at least three years, under a competent workman, in a shop where he has a chance to study the various kinds of work now demanded of the watchmaker. The trade is not as simple as it used to be. Our grandfathers were satisfied if the old "bull's eye" varied no more than five minutes a day, but now even the low priced watches are rejected if they vary that number of minutes in a month. Yet in those days seven years was the usual term of apprenticeship; now we see advertisements offering to make good workmen in three months, even to the extent of teaching that difficult art, adjusting.

I heartily endorse the movement leading to the organization of schools of horology, but are we not too fast in certifying that the three months graduates of these schools are qualified to take up

every class of watch work and do it as it ought to be done? If we are to have such schools let there be uniformity in the course of study; let it embrace all that a young man starting in the trade ought to know of both theory and practice, and let the course be long enough for the student to mentally digest and put in practice what he learns. There is, so they say, a quick method of fattening turkeys which produces fine birds in a few weeks by a process of stuffing. It may do for turkeys, but I have no faith in that kind of process for making watchmakers.

A smart young man may sit down and learn the theory of isochronism in half an hour, but when he has a watch put into his hands to be adjusted to isochronism, how many hairsprings will he spoil before he attains his object? The reason is that in watchmaking one thing is so closely connected with another and the principles are so interwoven, that it is impossible to single out one operation and learn it separately from others. If you tell me a man is a good adjuster, I at once imply that he understands the laws of friction, gravity and magnetism, the action of different shaped teeth upon each other, the best angle of impulse for tooth and pallet, the effect of heat and cold on various metals, and the proper portion of power to produce the effect desired with the least wear and tear. I do not believe there is a short cut to efficiency in the trade. No doubt the period of apprenticeship may be reduced below seven years and still be sufficient, but how much it may be shortened is a question demanding thought. With the present abundant supply of reading matter, a young man with good inventive faculty and natural ingenuity ought to be able to master the rudiments of the theory of timekeepers and gain a fair share of skill at practical work in three years, but in order to do this he must have a good common school education and some knowledge of physics, chemistry, geology and astronomy. A thorough knowledge of geometry is indispensable to one who means to go to the top, but this study can be pursued while learning the trade.

Many persons view the watch making trade as a purely mechanical one, but a little thought will show that if a man desires to excel in it he must have a very liberal education.

I want to say something about prices for work. I am aware that there is a great difference of opinion on this subject, and, of course, prices will vary somewhat in different sections of the country, but there is no excuse for the ruinous competition in prices of work which is now demoralizing the trade in this State. The causes which bring about this state of things are generally about these: Into a place well supplied with watchmakers comes a tyro in the trade, and straightway, in order to steal trade from the others, he begins to cut the prices of work. Some of the people of the town, who are always running from one store to another, immediately espouse his cause, and for a time make it appear that the old workmen have been robbing the people and that now they are to be emancipated from high prices; nothing is said about competency because nothing is known, and only after large numbers of watches have been spoiled does the fellow's trade drop off.

This matter would settle itself in a little time if let alone, but usually the other watchmakers take alarm and put down their prices for work, thus putting themselves on a level and in competition with unskilled labor. This leads to carelessness and haste in doing work and the struggle for a living becomes so difficult that there is no time for the study of improvements or for necessary recreation, and the consequence is the workman grows old, working hard, enjoying life but little, and gets rich in experience only.

Every watchmaker who has spent the time to master the trade ought to stand firmly against the proposition to in any way enter into competition with the botches, either in prices or quality of work done; for lowering the grade of work done in order to catch a close-fisted customer who "just wants the dirt brushed out," often works great injury to the reputation of the workman, because such a man, if the accuracy of his watch is questioned, will be quick to say that you fixed it, and he always forgets to say how much he paid for the

job, leaving the impression with the listener that you are no good.

Let us stand for fair prices for skilled work, and while we vote for protection from the results of pauper labor across the water, let us also vote to restrict the volume of pauper labor which is flooding this country, reducing wages and driving the American young men into the professions. Let us all stand together to elevate the trade and cause it to be respected by the people, notwithstanding the fact that botches will exist and be patronized by vacillating people, just as quacks and pettifoggers flourish in the professions.

J. W. HALL.

Vinton, Ia., August 13, 1889.

To the Editor of the Jewelers' Circular:

Please send me a receipt for satin finish silver. J. A. B.

[The common method of satin-finishing silver consists of satin-finishing brushes (called such) revolving on a lathe and acting upon the silver article. Of course, satin-finishing is a branch of a special trade, and one requires experience before good results can be obtained by even fully acting up to the receipt. We would advise you, if you have any particular job in hand to send it to some such gold and silver plater as F. Jeandheur, Jr., 4 Liberty place, New York, or Louis Newman, Jr., 36 John street, New York. The brushes can be ordered from any material and tool house.—ED.]

Montgomery, Ala., August 15, 1889.

To the Editor of the Jewelers' Circular:

There was a receipt in one of your journals for cutting glass, in which a liquid is used. Will you be so kind as to tell me the number of the journal or sell me the receipt? A. A. PEARSON.

[We cannot find in our files any article on glass cutting other than that which appeared in the May, 1888, issue: *To Engrave Glass*.—Some of the interesting effects obtained by Mr. Planti with his secondary batteries have suggested to him a new method of engraving on glass. The method he adopts is this: A plate of glass or crystal in a horizontal position is covered with a concentrated solution of nitrate of potash. Into the liquid layer and along the edges of the plate is introduced a horizontal platinum wire, connected with a secondary battery of fifty or sixty elements. Then holding in the hand the other electrode, formed of platinum wire, and sheathed, except at the point, with insulating material, you touch the glass with it at the parts where the characters are to be reproduced. A luminous track is produced wherever the electrode touches, and the lines are found to be distinctly engraved on the plate. The more slowly the operation is performed the deeper are the lines, and their width depends on the diameter of the electrode. Either electrode may be used to engrave with, but a less strong current serves for engraving with the negative electrode. Any source of electricity of sufficient quality or tension would serve for the purpose, for instance, a Bunsen battery or a Gramme machine.]

KIND WORDS.

Rochester, N. Y., August 1, 1889.

To the Editor of the Jewelers' Circular:

THE CIRCULAR has many competitors but it has not lost its grip. W. P. SMITH.

Pittsboro, N. C., August 14, 1889.

To the Editor of the Jewelers' Circular:

I do not want to miss a copy. W. H. LEONARD.

Warren, R. I., August 13, 1889.

To the Editor of the Jewelers' Circular:

I do not feel as if I could get along without it, for it seems like an old friend. A. J. MAKER.

Walsenburg, Col., Aug. 5, 1889.

To the Editor of the Jewelers' Circular:

I receive five other trade journals, but consider THE CIRCULAR as good as all the rest put together. JAS. C. LE CLARE.

Port Arthur, Ont., July 26, 1889.

To the Editor of The Jewelers' Circular:

I would have subscribed for it long ago if I had known it was only two dollars. I have read some old numbers that were lying about the shop, and have found them very interesting and helpful.

GEORGE H. RISCH.

Franklin, Ind., August 14, 1889.

To the Editor of the Jewelers' Circular.

I cannot do without THE CIRCULAR, so please send it regularly. CHAS. A. BECK.

Combination of Independent Full Second and Chronograph with Zero Setting.

AN EMINENT German watchmaker, Richard Lange, of Glashütte, has patented the following described invention: It is an arrangement by which the seconds hand of a watch either shows the fractional part of a second (ordinarily 0.2 second) or an independent full second; again, by the following described mechanism, the watch may be changed into a chronograph with zero placement, so that a watch furnished with this contrivance may be used for scientific purposes.

The arrangement of the mechanism for the conversion of a trotting into an independent second, or the reverse, is shown in ground plan in fig. 1, while figs. 2 and 3 show two other positions of the active parts for converting the watch into a chronograph with zero placement.

The watch movement, omitted in the illustration, unites at the

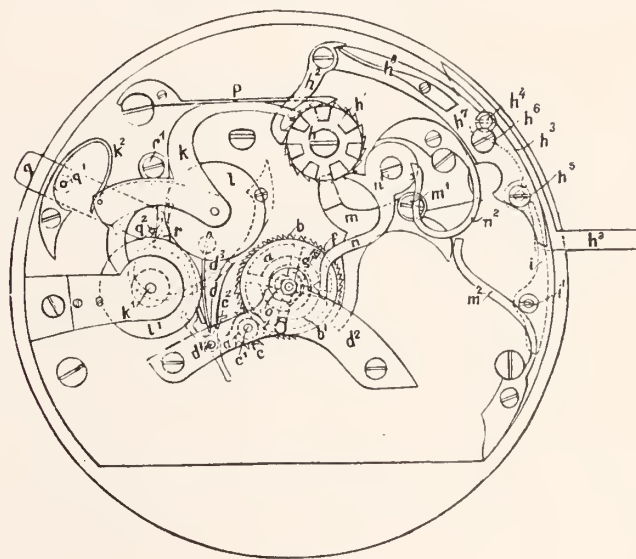

FIG. 1.

axis k^1 of the wheel l^1 , fig. 1, and the occasioned rotary motion is by the wheel l transported upon the chronograph wheel a . Underneath the chronograph wheel a , fig. 1, loosely sitting upon the axis of the seconds hand, is the seconds independent (spring) wheel b , firmly sitting upon said axis, and provided with 60 teeth; both wheels are by a fine spiral spring, b^1 , united with each other. For the propulsion of the wheel b and seconds hand in independent full seconds sitting upon its axis, sits upon the axis c^1 , pivoted in the bridge d^2 , a small unlocking wheel, c , which by the springing (independent) full seconds unlocks a lever, d , revolving at d^1 in the bridge d^2 from the teeth of the wheel b , by means of an arm, c^2 ,

whereby the wheel is detained from second to second, and the seconds hand sitting upon its axis, springs a full second. Upon the arbor c^1 sits beside this a small wheel, a^1 , which is in constant dephthing with the chronograph wheel a . The lever d is thrown into gear in the teeth of the wheel b by a fine spring, d .

By showing the fractional part of a second (0.2 second), the lever d is disengaged from the teeth of the spring wheel b ; the latter becomes free thereby, and revolves forward until a small pin, f , projecting upward from the wheel b , strikes against one of the limits of the slot g in the disc of the wheel a . By this, the two wheels a and b journey together and show 0.2 second.

h is an intermediate wheel with raises and hollows; to its lower part joins a ratchet wheel, h^1 , into the teeth of which depths a tooth, h^2 , pressed on by spring h^3 , by which is effected a continued motion of the wheels h h^3 by pressure upon the lever h^3 . This lever, h^3 , which is at h^4 fastened to the lower plate of the watch in such a manner that it can revolve, applies itself with one of its edges against the pin h^5 , which passes through the upper plate of the watch and to which is fastened at h^6 lever h^7 , with a revolving capacity. By means of a strong spring, i , which lies underneath the upper plate of the watch, and which at i^1 is fastened with a revolving capacity to the lower side of aforesaid plate, and which with its hook-like end applies itself against the pin h^5 is continually pressed to the inside of the long end of the lever h^7 , which carries above-mentioned lever h^8 .

k is a pivoted detent with a revolving capacity pivoted at k^1 ; its front end applies itself alternately against the raises and in the hollows of the intermediate wheel h , which is secured by spring k^2 . In

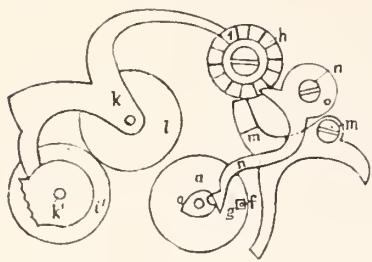

FIG. 2.

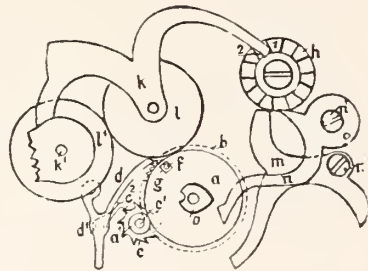

FIG. 3.

the center of the pivoted detent k is pivoted a wheel, l , which alternately engages into, and disengages out of, the chronograph wheel. Against the intermediate wheel h also apply themselves beside the end of the detent k : the lever m , which can revolve at m^1 , and which by means of the spring m^2 is constantly pressed in the direction against a heart, o , upon the chronograph wheel a ,

The further progress of the ratchet wheel h^1 by more than one tooth is prevented by the spring p dephthing into its teeth. For the purpose of engaging the lever d into the teeth of the second-springing wheel b , near to the circumference of the upper plate of the watch, at q^1 is pivoted with a revolving capacity, lever g , the end of which, lying toward the center, is beveled. Against this bevel is applied a pin, q^2 , which, passing through the upper plate of the watch, protrudes to one side of the lever r , with revolving capacity at r^1 . The free end of the latter lever ordinarily holds the lever d out of dephthing with the wheel b , but for the purpose of an engagement of d in b it liberates it, in order to push this lever d by the operation of the spring d^2 into the teeth of the wheel b .

The conversion of the watch first into an independent and then into a chronograph, or the reverse, is effected in the following manner:

If the parts are in the position of zero (fig. 2), then by pressing upon the lever h^2 the ratchet wheel h^1 is advanced by one tooth. By this advance, the raise 1, fig. 2, revolves so far that the free end of the detent k drops into the next hollow, 2, fig. 3; by this the wheel l , sitting on the detent, dephths into the chronograph wheel a , fig. 3, so that the watch is from XII or Zero forward converted in

its course into an independent or swinging full second, after the lever d is intercalated by the lever g , fig. 3.

By converting the watch into a chronograph, the wheel l remains in dephthing with the chronograph wheel, but the lever d is disengaged by the sliding back of the lever g out from the teeth of the wheel b , so that in consequence of the stretched spiral spring b the pin f applies itself against the limiting edge of g , so that both wheels journey in common by 0.2 second.

By this single advance of the ratchet wheel h^1 , the two other levers m and n , applying themselves against the intermediate wheel h , have remained stationary upon the raises of h , so that they could not alter their position. By the second pressure upon h^3 , however, the front end of the lever m drops into the next hollow, fig. 1, whereby the springing wheel b , together with the hand upon its axis, is retained. A third pressure upon the lever h^3 permits also the zero lever n to drop into the corresponding hollow, fig. 2, whereby its other end applies itself against the outer plane of the heart piece o , in order to bring back the springing wheel b to its zero position by a pressure upon the spring n^2 .

In order to cause the watch to go on in the ordinary manner, it is only necessary, if it has run previously as independent (springing) full second, to push back the lever g out of its initial position. In the ordinary march of the watch, the wheel l^1 then turns loose, whereby also wheel l is then set loosely into rotation. By a repeated conversion of the watch into the independent full second or chronograph, pressure is again exerted upon the lever h^3 , fig. 3.

The previously described arrangement admits of four different styles of execution:

1. Only as constant full independent second. In this case, the three wheels, l , l^1 and a are pivoted in an immovable bridge. This disposition then consists only of the wheels l , l^1 , a and b , remaining in steady dephthing, as well as the small unlocking wheel c , and the unlocking lever d .
2. As independent second with stop motion. In this case, instead of the stationary bridge a movable one is used, so that by stopping the wheel l is brought out of dephthing with the wheel a .
3. As independent second with stop motion and conversion into a chronograph. This style of execution dispenses with the zero position of the patented disposition; consequently the heart piece o , the zero lever n and the spring n^2 are omitted.
4. As independent second with stop motion and zero placement, as well as conversion into chronograph, as described above.

QUALITY OF A POLISHER.—The first principle to be observed is that a polisher must be softer than the thing to be polished. This principle admits of no variation. Hard steel, for instance, may be brought to a fairly good surface with soft iron; but with steel of less temper, bell-metal zinc or tin must be used according to the temper of the piece under treatment. It will be found as a rule that larger surfaces require softer polishers than smaller ones. This may be accounted for by the hand polishers cutting the large surface too fast and so charging the polishing stuff with the worn metal. This fact is most observable in large pieces polished under hand. The indications of a polisher being too hard is a dull, seamy, milky-looking surface. If covered with sharp scratches, the fault is more likely to lie in the polishing stuff than in the polisher. A too soft polisher will produce a surface apparently covered with minute flaws, known in the trade as "specky." The foregoing remarks are meant to apply to steel pieces, and the same general principles hold good in the case of brass, though it may be remarked in passing that to polish brass well is far the more difficult operation of the two. The substances used for brass are soft tin, whalebone, horn and hard wood. All are good, especially the first.



INTERESTING REMINISCENCES.—A very interesting volume of reminiscences has recently been published by Madame Corette, who, before her marriage, occupied the position of reader to the Empress Eugénie. Frequent mention is made in the book of a brooch in the form of a trefoil, composed of large emeralds surrounded by brilliants. When the Empress dressed for dinner, it was always placed among the folds of her low bodice, no matter what other gems she chose to wear. This custom was continued in exile until the death of the Emperor. After the tragedy in Zululand, which deprived her of her only child, she gave the brooch to her kinswoman, the Duchesse de Mouchy, as a memento of the past. As we know, many of the Crown jewels were remounted for the use of the Empress, and among others was a yellow diamond, of large size, that had a curious history. During the revolution of 1848, when so many of the Crown jewels disappeared, this stone was stolen by one of the insurgents, who swallowed it to avoid detection. It gave rise to a terrible malady, from which he died, having, however, confessed his theft. At the post mortem examination the diamond was discovered and restored to the government treasury. One day the story was related to the Empress, and she never afterward wore the comb in which the stone was mounted.

"UNEASY LIES THE HEAD THAT WEARS A CROWN."—In another part of the book Madame Corette describes how the Empress was often much fatigued by the weight of the jewels with which her person was ornamented for grand balls and other ceremonies, and how, as soon as she would reach her own apartments, before summoning her women, she would take the diadem from her head and the jewels from her neck, and throw them to her "reader." It is amusing, also, to learn that the Imperial household, being kept in ignorance of the Emperor's projects, became expert in making surmises as to them. Thus, for instance, every one knew that when a gold tea-caddy, which had belonged to Napoleon I., was absent from the tea service that a journey was in contemplation, as Bignet, First Groom of the Chambers, had packed it up for departure. If the journey was postponed, or fell through, the tea-caddy reappeared.

THE ANTIQUITY OF SUN-DIALS.—Charles Lamb was possibly not far wrong when he conjectured that Adam had a sun-dial in Paradise. Dials are probably older even than alchemy. The Babylonians had them, though the Egyptians, that wonderful people who knew most of the things the moderns have re-discovered, seem not to have used them. The Babylonians gave them to the Greeks; the Greeks to the Romans; and the Emperor Trajan is credited with an epigram upon the art of dialling. Naturally, dials are most frequent in lands where the sun shines as a matter of course and not as an act of courtesy and complacency. French and Italian gardens are full of them, and they are affixed in hundreds to the walls of sunny châteaux. In days of yore, when there was time for sentiment, and room for it, sun-dials were favorite gifts from great personages to one another, from people to princes and from princes to people. Cosmo de Medici, whose fitful humors so angered Benvenuto Cellini, gave one to the Florentine students of astronomy, and it still marks the time of day on the walls of Sta. Maria Novella. Sun-dials may even be found in England. They there bear various legends, such as "Tempus fugit," "The Hour of Drinking." A grim old joke is that of the Englishman who had engraved upon his sun-dial, "We must and shall ere long dyall."

WHAT THEY KNOW OF US IN FRANCE.—The *Moniteur* says that a new gold mine of a fabulous wealth has been discovered on the Mexican border, between Mesilla and El Paso. One of the prospectors found a nugget of gold valued at 65,000 francs which is at pres-

ent exhibited in the window of a money broker in Nevada.

DIAMONDS.—The diffusion of wealth, which is one of the most noticeable features of the progress of the nineteenth century, has led to a steady appreciation of all gems, particularly of diamonds, which have completely changed their position in the public esteem since Benvenuto Cellini appraised them at one-eighth the value of rubies and one-fourth the value of emeralds. In spite of the vast output of the African mines, there has been a steady increase in the market price of diamonds for many years past. One curious fact is noticeable in comparing the rates of to-day with those of a quarter of a century ago, namely, that it is the stone of moderate size which has risen most in value. The middle class are ready to absorb these steadily in enormous quantities, while gems of royal and ducal magnitude only find purchasers after there has been a successful "corner" in New York or Chicago financial circles.

TRIAL OF DECK WATCHES AT GREENWICH.—The observer royal, Mr. Christie, at the Greenwich (Eng.) Observatory, gives notice that the trial of deck watches at that place will commence on October 26, and that timepieces will be submitted to the following tests:

Watch, horizontal, dial up, in room for 6 weeks;	
“ “ “ in oven for 1 week;	
“ vertical, pendant up, “ “ 4 days;	
“ “ “ right, “ “ 3 “	
“ “ “ left, “ “ 3 “	
“ “ “ up, “ “ 4 “	
“ horizontal, dial up, “ “ 1 week;	
“ “ “ in room “ 6 weeks.	

The mean temperature in the oven will be from 80° to 85° F. The watches are to be in silver cases, with crystal glass, and each must bear a distinguishing number engraved on the plate of the movement. Preference will be given to stem-winders.

GRIM HUMOR.—Burglars entered the jewelry store of a large manufacturer in Leipzig, and made off with a very heavy booty. Shortly before this occurrence, the jeweler had a bronze medal struck, for some purpose or other, with the inscription (in German), "Learn to suffer without complaining." The considerate burglars left one of them in a conspicuous place in his safe, by way of consolation we suppose. It is, however, better "to give than to receive," which refers principally to advice and medicine.

WEALTH.—At the Loan Exhibition in a Vienna palace, there is a marvelous display of jewelry. An eastern paper says: "Five large rooms are filled with such things as emerald and diamond diadems, necklaces, coronets, tables of solid silver, big chairs set with silver, huge mirrors framed in silver, toilet services of solid gold, and golden cups and tankards by the hundreds. There is a necklace belonging to the Princess Metternich in which are set the biggest emeralds in the world, and the Princess Russ shows a necklace made up of the largest opals known, some of them as big as peaches. The Duke of Nassau exhibits a small case, for the contents of which he has just refused a quarter of a million dollars. The case contains two golden tankards surmounted with Roman heads in relief, and having miniature portraits of the German Emperors encircled by big diamonds inside the lids of both tankards. Among other trifles may be seen the great Napoleon's golden travelling dressing case, and some queer-looking golden instruments with which he used to pick and clean his imperial teeth.

BOGUS TURQUOISES.—A German merchant discovered, during the recent fair at Nijni-Novgorod, that the turquoises offered for sale by the Persian traders in those stones were nearly all false. These rogues have been imposing paste upon their customers for the last six or seven years, and it is estimated that, out of about 100,000 turquoises which have been sold during that period, not more than 10,000 were genuine stones. The imitations are described as marvellously clever.

Cylinder-Plugging Tool.

THE American repairer's bench is doubtless well provided with tools and auxiliaries of every description to assist him in the often difficult labor of repairing. By far the greater part of the repairs coming to him are those of the American watch, Swiss, German, and a few French anchor watches, and the English patent lever—all of them anchor movements of one kind or another; cylinder watches rank perhaps second in importance; the duplex and tourbillons are fast disappearing, and will soon be found only in watch collections. Cause, "too complicated."

The plugging of a cylinder is occasionally a disagreeable job, especially if the repairer's bench does not contain an assortment of proper tools to assist him. An exchange, *L'Union Horlogère*, contains an article, with illustration, on the plugging of a cylinder, by Mr. H. Ganio, watchmaker at Crémilú, France, which appears to be worthy of consideration, and THE JEWELERS' CIRCULAR transfers it to its pages. He says:

"I have been extensively engaged in pivoting and all that pertains to it, and I believe that I render a service to my brother 'pivots' by giving them the description of a simple and practical cylinder-plugging tool, which greatly diminishes the risk of accidents; this I can state by experience, as I have used the tool with eminent success for the past three years. It is easily made, and its construction requires only a little patience and reflection. The tool was invented, I believe, by a watchmaker, living in Saucerre. His name is unknown to me.

The accompanying illustration shows the little tool in its original

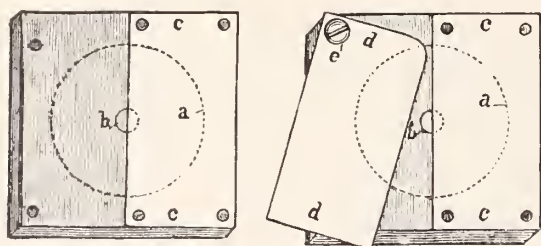

FIG. 1.

FIG. 2.

size; it consists of three square pieces firmly riveted one upon the other, and a movable plate. It is made in the following manner:

Two entirely uniform square plates of 30 millimeters side length are made first. The lower or fundamental plate is of brass, 8 to 9 mm. thick, and has a hole drilled through it of about 20 to 22 mm. in diameter, as shown by the dotted circles *a* of figs. 1 and 2. The second plate, of the same size, is made of steel plate, from 0.8 to 0.9 mm. thick, and through its center is pierced a hole from $2\frac{1}{2}$ to 3 mm. in diameter (the small dotted circles shown in the cuts and marked *b*). Another, a third, plate *c c*, figs. 1 and 2, still remain to be made of sheet steel. Since this plate must be sufficiently thin, so that it can be passed into the cylinder notch of a 12-line watch, a piece of clockspring can be used. The plate *c c* must be only one-half as large as the first two, so that, when laid upon the right side of the large steel plate, the hole *b* of the latter is covered one-half. In the cut, that part left light represents the small, thin steel plate, and the darkened part the large steel plate lying underneath.

In the same order as that of the description, the three plates are laid exactly one upon another, and six holes are drilled through them. After the hole for the screw *e* (fig. 2) has been made in the two lower plates, the steel plates are hardened, annealed blue, and the three plates are then riveted upon one another. It is unconditionally necessary to pay strict attention to having the two steel plates close perfectly flat upon each other, as the tool might under other circumstances comply with its functions but imperfectly.

Only the last part still remains to be made, which consists of a steel plate, *d d*, fig. 2, of exactly the same dimensions as the plate *c c*. The steel plate *d d* is with a screw, *e*, fastened upon the left side of

the steel plate in such a manner that it can be slid horizontally while lying perfectly flat, as shown in fig. 2. The pins by which the first three plates are held together must be fully countersunk, and the rivetings must not protrude in the least. In order to facilitate easy motion, so that the plate *d d* can be made thus that it can close exactly with the plate *c c*, its upper right corner is rounded off.

The tool is used in the following manner: When an upper cylinder plug is to be driven in, the plate *d d* is slid aside to the left, and the cylinder is pushed through the half center hole *b* in such a manner that the sharp edge of the plate *c c* seizes into the large notch of the cylinder, and this lies firmly upon it. The plate *d d* is then carefully pushed against the back of the cylinder and screwed tight in this position by the screw *e*. The cylinder lies now in a position both very convenient and secure for the driving in of the plug, so that this work may be done in the ordinary manner without any danger, by the use of a corresponding hole punch.

If a lower plug is to be driven in, the cylinder is from below pushed through the half center hole *b*, after the plate *d d* has been pushed to one side. The short end of the cylinder is thereby supported upon the plate *c c*, by introducing its edge in the cylinder notch, after which by the plate *d d* the cylinder is fastened in entirely the same manner detailed for the driving in of the upper plug. The large sink of the lower plate fully accommodates the balance, and diminishes the danger of damaging it. It is a special preference of this tool that the repairer can use it comfortably before him upon the work bench, while under other circumstances he has to use the vise, by which the operation is seldom performed without the dropping out, if not breaking, of the cylinder."

To Plate with Aluminum.

L. Q. Brin, of Paris, France, furnishes the following method for plating with aluminum:

The process which constitutes this invention is intended for depositing a coat of aluminum upon a metallic surface by the direct contact of a volatilized salt of aluminum with the surface. The sheets of iron or other metal are first of all cleansed from all impurities by an acid bath, and they are afterward plunged into a solution of borate of soda, hydrated alumina, and some easily fusible flux, so that the surfaces shall be preserved in a state of perfect cleanliness. The articles which have been treated in this manner are placed within a closed muffle, and the walls of the muffle are heated to a very high temperature by a surrounding furnace. There are openings in the sides of the muffle to provide for the entrance of the vapors and for the escape of the gases resulting from their decomposition.

Some salt of aluminum, such as the chloride, is heated in a vessel of fire clay to the temperature of volatilization, and it is then conducted through the muffle in direct contact with the surfaces of the plates. The aluminum is at once separated, and it is deposited upon the metallic surface. A current of inert gas, such as nitrogen, is forced through the retort and muffle along with the stream of aluminum vapor, so that no oxidation shall be possible. The outlet tube from the muffle conducts the residual gases into a receiver, upon whose condensing surfaces the sublimated vapors are deposited for further utilization as by-products. In this operation of plating it has been found by the inventor that the metallic sheets are not only covered with a coating of aluminum, but that they become impregnated with it to such an extent that it may be considered that they are composed of an alloy of the two metals.

TO SHARPEN A GRAVER.—The best way to turn up the point of a flat graver is to stone away the sides of its belly first until the point assumes, for about a quarter of an inch backward, somewhat the form of a knife blade. It is then easy to stone off the thin edge until the right pitch is obtained, and equally as easy to secure the exact width and proper form of belly—slightly widening towards the point.

WORKSHOP NOTES



TO SHARPEN A GRAVER.—Do not sharpen the face of a graver in the middle of the stone. The face of a graver must be sharpened the oftenest, and in doing that the stone receives the greatest wear. The face of a graver should be sharpened near the edge (not the end) of the stone, as near the top edge as possible, for if the *lower* end be used, and the tool during the operation slip off from the stone, its point is almost sure to be rasped away, and the cutting edge of its belly seriously damaged by the accident. Use the *top* edge, and avoid the danger. By following this advice, the largest portion of the face of the stone is kept in good order for sharpening graver bellies.

TO BEND A GLASS TUBE.—To make a bend in a glass tube without flattening, two inches of the tube should be heated to an equal temperature. This may be done by holding the glass width-wise in the flat flame of an ordinary gas burner.

REST YOUR FILES.—When you are doing a difficult filing job, use two or three files. They seem to take hold better and work more free from having had a "resting spell." Perhaps it is because different files fit the hand differently, and thus furnish rest and a change.

SILVER PLATING FLUID.—Dissolve one ounce of nitrate of silver in crystals in twelve ounces of soft water; then dissolve in the water two ounces cyanide of potash; shake the whole well together and let it stand till it becomes clear. Have ready some half-ounce phials, and fill half full of Paris white or fine whiting, and then fill up the bottles with the liquor. It is ready for use. The whiting does not increase the coating power; it only helps to clean the articles and saves the silver fluid by half filling the bottles.

STRONG CEMENT.—Mix some finely-powdered rice with cold water, so as to form a soft paste. Add boiling water, and finally boil the mixture in a pan for one or two minutes. A strong cement is thus obtained, of white color, which can be used for many purposes.

TO KNOW PURE GILDING.—By applying a solution of chloride of copper the difference between gilding for which solid gold has been used or gilding with alloys of inferior metals will be seen. If the gilding is imitation gold, a touch of the solution gives a black mark, copper separating out through the zinc in the yellow metal; with pure metal, no discoloration occurs. The test can also be effected with a solution of chloride of gold, or nitrate of silver, the first of which gives a brown spot, the second a gray or black spot, neither, of course, having any effect on gold. Common gold goods do not change their color with nitrate of silver. Leaf gold is tested by being shaken up in a closed bottle with sulphur chloride. Beaten gold shows no alteration, while "metal" leaves grow gradually black.

THE ESCAPE WHEEL.—At the beginning of motion the escape wheel acts by a continual pressure on the pallet impulse faces; usually through about two-thirds of the impulse portion of the escapement arc being one half of the whole arc of the escapement, reckoning the impulse and unlocking together; and at this half-way point of the whole arc the reciprocating spring and balance are at rest when the mainspring is down.

FOURTH PINION.—The undercutting of the fourth pinion at the bottom pivot is necessary to keep the oil in the sink, and the pinion left no higher than the third wheel requires, or it may foul the balance or banking pin.

TO REPLACE A BROKEN FOOT JEWEL.—Remove the broken jewel from the collet or setting in one of your lathe chucks, large enough to hold the same; start in motion, and with a fine pointed burnisher raise the bezel sufficient to receive a new jewel; select a jewel to fit both pivot and setting, replace in the chuck, close down the bezel on the pivot with a little larger burnisher, and the job is complete.

THE FORK.—The fork and its connections require the special care of the watchmaker. They are the hiding place of a number of errors. The limits of the motion of the fork are of great importance. Its motion should be as small as consistent—that is, the fork must have accomplished nearly its motion at the time when the tooth drops. The banking of the fork near its fore end must be corrected, because sticky matter, consisting of oil thickened with dust, fibres, etc., will collect there, and the fork will stick to the side at every beat, and require a certain amount of extra force to tear it off again; consequently an extra waste of power. In order to prevent this, insert two round banking pins, which, being round, will present little surface.

NEW PINIONS.—In putting in a new third pinion, it is necessary to undercut the shoulders and leave a hollow in the pinion, or the oil may work into the leaves of the pinion and center-wheel teeth. Before the wheel is riveted to the pinion, the balance is to be put in to see if it is free, as in some callipers the circle intercepts.

UNDULY GREAT VIBRATION.—A very troublesome fault in some of the best class of Swiss watches is a too great vibration, causing the balance to strike the bankings. It is most often found in watches having large wheel teeth with straight inclines. The more modern practice is to curve the acting face of the teeth, and a slight alteration of the tooth diminishing the incline at the heel of the tooth will always diminish the amount of vibration.

DRILLS.—It is not sufficient to have a well-tempered drill for drilling hard stuffs, arbors, etc., without blueing them. In drilling, drive the bow by feeble jerks, so that the bottom and sides of the hole do not become polished, for otherwise it would be impossible to continue the drilling.

CEMENT FOR LABELS.—Mix pure dextrine with boiling water, until it assumes the consistency of ordinary mucilage. Apply the mixture with a full, evenly-made camel's hair brush. The paper should not be too thin or unsized.

ADVANTAGE OF THE TWO-PIN ESCAPEMENT.—If a two-pin escapement has an advantage over a one-pin escapement, it depends upon the attainment of the following points: First, the impact of the pallet impulse face and drop across the guard pin should be nearly simultaneous blows; hence there must not be a very long drop across the guard pin in the roller notch, or the blows will not come so near together, as the first and perhaps the chief impulse is so clear, and so near the line of centers, this is the most effective line of impulsion. Another merit of centers is that, by the great width of the lever notch the position assumed by that side of the notch which effects the unlocking allows the leading pin, on coming in, to take hold of the notch at once.

SCREW THREADS.—It requires quite a knack to make a nice screw, and beginners are apt to use too much force when cutting the thread. If the spindle has been turned too large for the hole in the screw plate, there is danger of breaking the latter; again, the piece to be tapped is apt to break and stop up the hole in the plate, entailing the tedious job of drilling out the piece and cleaning the thread. It is better to begin with a hole much too large and work down gradually. It is natural that a certain amount of force must be employed, and a little practice will soon teach the beginner how much is necessary to insure a full, good thread. Then put the screw back in the lathe and turn the head a little more than the required thickness, and cut the thread off turning a groove out.

OILSTONES.—If the watchmaker's oilstones are without boxes, he cannot do better than buy them. Good oilstones, kept in good, clean condition, are a means of first importance in keeping tools as they ought to be kept. With a covered oilstone, the oil upon it is kept in a liquid state for as long a time as it can be. The oil not becoming sticky, the pores of the stone do not, as they otherwise would, become filled with a gummy substance that diminishes its power, if it does not destroy it altogether. With stone and oil clean, the work of sharpening gravers is rapidly and easily done.

The Motive Force in Watches.

MR. OSCAR PERRET, of Les Novettes (St. Imier), says, in the *Journal Suisse d'Horlogerie*: It should appear that this question were worthy of meriting the attention of all those engaged in watchmaking; nevertheless, this is far from being so, because it is the most neglected part, to such an extent, even, that many watchmakers do not trouble themselves at all to study the important works which this force produces, nor the parts that consume a portion of it. It appears that the moulder has no other duty to perform than that of imprisoning the spring within the barrel, lubricating it with a little oil of an inferior quality, without further troubling himself whether it runs without being cramped or whether its force can develop as it should. This is due to the fact that the motive force labors under one disadvantage. Its motions cannot be seen and studied like those of the other movable parts; were this so, one can be certain that it would be the object of greater care, and it would be more highly esteemed.

... It is rarely the case that the mainspring is examined; this fact is left to the good faith of the spring manufacturers, who may employ either steel of a bad quality or badly tempered; nor is any rigorous exactitude exerted as regards the height or thickness of blade, etc. Such as the spring is, it is delivered to the moulder, whose duty simply is to put it in place regardless of the condition in which he receives it. It is not astonishing, therefore, that the greater part of these springs cannot but very imperfectly comply with the functions they are to discharge, and they become a source of imperfection to the watch, even when all its other parts are in fair order.

We have said that the mainspring performs a very important part; it produces a force which must be preserved as nearly intact as possible. The barrel being actuated by this force must, in its rotary motion, actuate an entire mechanism, and its energy experiences a diminution from one wheel to the other, so that when it arrives at the escapement a large part of the original force has been consumed by the many frictions of the depthing and pivots. Theory can with precision calculate this loss. To this may be still added the imperfections of construction, bad proportions, etc., which augments the intensity of the frictions and consequently requires more force.*

In order that the mainspring may comply with its functions passably, it must be capable of exerting a uniform traction force for at least twenty-four hours; it would thereby favor the regularity of the amplitude of the balance vibrations, which is very important for the adjustment. But experience has taught us that it is not always an easy thing to attain this result, because it is well known that the manufacturers of steel have not yet been able to produce it with a regular force, and, consequently, springs with a uniform action in the same conditions are the result. Nothing, indeed, is more interesting than experiments on their action, to prove the irregularities produced by them, as far as their traction is concerned, even with springs of the same height and thickness of blade; this irregularity is a great defect.

I would like to call the attention of young watchmakers to one point: it is better in order to have more force of augmenting the breadth of the blade rather than its thickness, because less is lost of development, and the traction is much more regular from the beginning to the end of the performance—that means that the differences are not as great in the extremes; we have been able to observe this fact in a number of instances, and it is easy to prove the truth of the assertion by instituting experiments.

The friction produced between the coil blades during the activity of the spring is also of great importance, and becomes so much more injurious as the spring is out of truth, that is to say, when it unfolds to one side. It is fairly difficult to ascertain the origin of this, and

* Experiments instituted have demonstrated that the train (wheels, pivots, depthings), when in proper condition and lubricated with fresh oil, absorbs about 20 per cent. of the motive force.

the inquirer frequently loses much valuable time in ascertaining it. In the common watch, where the price naturally does not permit any very exhaustive inquiry, much could nevertheless be done toward ameliorating this evil.

The barrel must be free upon its arbor like any other movable piece in the watch; the spring must be unconditionally free to develop with the greatest ease. The pivot holes and spring must be lubricated with a suitable oil of good quality. The repairer will frequently find a bad oil which rusts the steel and produces very injurious friction. One grave error often found is that the core is too large.

We might say much on the question of the stopwork, because it must be acknowledged that many watchmakers do not at all inquire into the utility and duty of this little mechanism. It is often the case that repairers take it out altogether because they do not understand its functions. The stopwork has its well-defined utility, if it is kept in good order, and especially if it is made to comply with its functions, to wit, of utilizing the turns which give the greatest equality in the tractive power.

By barrels for which no stopwork is used different stop systems are employed, and they are oftenest in bad condition, either by the space they occupy, the little quantity of solidity which they possess or the disagreeable friction produced by them. We have been able to observe frequently that in many cases the collar-stopping contrivance hinders the spring from unfolding. Although certain kinds of collars do not produce this effect, and thus enjoy an advantage over other kinds.

As regards the quantity of force to be employed, there are laws governing this question in a rational manner. Generally speaking, there is more force than is necessary, but by reason of the want of care this excess is completely absorbed.

It is often asserted that the Americans use springs which are too strong. It is necessary to do them this justice, however, that their springs are proportioned to the barrel, and that if they employ large barrels their trains and escapements are in the same proportion. One difference to be noticed is that they have employed a much smaller but much thicker balance than we. In Switzerland the principle governs that the watch must march with the least possible force. It is an old principle which exerts its full value, especially for fine grade watches; but when it concerns watches "by the thousand," which must be manufactured at a very low price, the question is no longer the same. We must admit that the Americans have abandoned this principle for a very simple reason: Their watches, as well as our own, possess imperfections which would cause them to stop, and, above all, to go badly. Now, it must be acceded that these defects are compensated to a certain extent by the resistance of the motive power, which is much stronger than in our watches.

We do not desire to say that American horology is of a better quality, but we would rather speak of the advantages of their style of manufacture, because we know the time spent on watches with an unsatisfactory march. We know that the American watch possesses certain defects which we would not let pass without employing stopwork. We must admit, however, that in the manufacture of current watches the Americans thus possess an advantage over us. It may be objected that the wear is too great, but if the movement is worn out before the case, the former may be replaced at little expense.

THE WATCH REPAIRER.—A mechanical eye is almost an absolute necessity for a watch repairer. Whenever you have a piece to make, it should be made so that if the man who made the watch were to examine it, he could not detect the piece replaced unless by superior excellence. All the botch makers of the trade have no idea of finish; their only idea is to put in something that will work, no matter how unsightly.



* A Complete History of Watch and Clock Making in America.

[By CHAS. S. CROSSMAN.]

Number Thirty-Seven.

Continued from page 83, August, 1889.

WATCH CASE MAKING

SOLIDARITY WATCH CASE CO.

The Solidarity Watch Case Co., co-operative, of Brooklyn, N. Y., was organized in the early part of the year 1885, and was incorporated under the co-operative laws of the State of New York, July 1, 1885, with a capital stock of \$50,000, divided into 2,000 shares of \$25 each. At the annual meeting of the shareholders in 1885, the following officers were elected: M. Lewis Donniez, President, Frederick R. Sprake, Vice-President, Frank E. Hurmer, Secretary, D. E. D. McMurray, Treasurer and Superintendent, and a Board of Directors consisting of nine members, three to serve for one year, three for two years and three for three years. The Board of Directors have the entire management and control of the business. The superintendent has the entire control and management of the factory.

No person can become a shareholder unless he is a practical workman engaged in the watch case trade and a member of the Watch Casemakers' Association, and each shareholder has one vote irrespective of the amount of shares he may hold. The profits are divided among the shareholders according to the amount each has invested.

The company commenced manufacturing October 9, 1885, in the top floors of 242 and 244 Plymouth street with eight men in their employ, and have been very successful. Only solid gold cases of first-class workmanship were produced, together with a line of specialties, such as diamond, raised gold and highly decorated cases (on which they have several patents), for which a ready market was found. On the 20th of June, 1887, the factory was destroyed by fire, causing the company considerable loss. The three story and basement building, No. 11, 13, 15 and 17 Hope street, was then taken and fitted up by the company, and they now occupy the whole building. The output has steadily increased to such an extent that there are now employed ninety-four men, one woman, two girls and five apprentice boys. The New York office of the company at 194 Broadway is in charge of Simon Goldsmith.

DUBOIS WATCH CASE CO.

The Dubois Watch Case Co. was established in Brooklyn, May, 1887, as a stock company, the officers being L. Duval, President, J. Depollier, Secretary and Treasurer, and J. Dubois, Superintendent. Mr. Depollier was the chief promoter of the enterprise, withdrawing from the Willemin Watch Case Co., of which he was President, and taking with him Mr. Dubois, who was then superintendent of the case turning department of the Willemin Watch Case Co. The pro-

duct of this company is chiefly in fine ornamented cases with raised gold ornamentation, full bassine engine turned and Jurgensen cases being a specialty. This company has prospered in two years. At starting they employed only about 18 hands, while to-day they employ from 40 to 45. They have an office in New York at No. 2 John street, which is in charge of L. Combremont.

ROGERS, LANGDON & WENT

Started case making about 1852 at No. 4 Court street, Boston, the firm at first being Rogers & Langdon. Rogers and Went were silversmiths and were not actively connected with the business. The firm did fairly well until the panic of 1857, when they were obliged to discontinue. Mr. Rogers then moved to New York and continued in business until his death. Mr. Langdon carried on the case business until 1862 or 1863, when the war having broke out he engaged in fitting out two companies of sharpshooters and gave but little attention to case making. The elder Margot was in their employ and succeeded them in the case business. When Mr. Margot died the business passed into the hands of the present firm of Margot Bros., 23 Water street.

MARGOT BROS.

A. A. and A. P. Margot started in December, 1861, buying out a man named Catlin, at 4 Court avenue. They employed no one at the start. In 1866 they moved to their present location, 23 Water street. A. P. died subsequently and was succeeded by another brother, E. J. The firm was always Margot Bros. They employ about twenty hands and manufacture chiefly gold cases.

CHAS. L. THIERY.—THE THIERY WATCH CASE COMPANY.

Before going into the history of this company, a brief account of Mr. Thiery as an individual casemaker will be given. He is a native of Switzerland, but came to New York City with his parents in 1832 when a lad of 8 years. He served an apprenticeship with Julian Favre, who was then located in Ann street. In 1844 he started in business for himself in William street near Frankfort. Here he remained until Samuel Way, a capitalist, of Boston, induced him to give up his business in New York and start a gold case business in Boston. This was the first effort in that direction that had been made there. He removed there in October, 1848 with his family and two apprentices, Wm. Lahey and John Carlock. (The latter furnished the writer many of these facts).

Mr. Thiery started the business in an old wooden building on the corner of Harrison and Orange streets (now Way street), Mr. Thiery superintending the work and Mr. Way furnishing the capital. After a few months Mr. Thiery became the sole owner of the business. He had in his employ at that time as his principal workman Wm. Tracy, now of Philadelphia. George Thiery, a brother who accompanied Chas. L. from New York, also became interested in the business. The business was continued at this location for about five years, when Mr. Thiery bought a house in Cambridgeport and had his shop adjoining. In March, 1858, he removed to Boston and took a partner, John Serex, who had previously been with Rogers, Langdon & Went.

The firm became Thiery & Serex, and they were located in Graphic Court. From there they removed to School street, and then to the present location of the company, Harvard Court and Washington street. Mr. Serex withdrew from the firm subsequently. The present Thiery Watch Case Company was organized in 1876 with a capital of \$50,000. Mr. Thiery was made superintendent and took an interest in the company financially. The company, of course, use his patents which cover the making, or, rather, the spin-

ning of watch cases. The centers, backs and fronts of the cases are spun from a thin flat piece of metal, no turning whatever being necessary. They go through about ten operations previous to jewelery. The manufacture under these patents is mostly confined to nickel cases, of which they turn out large quantities. To work out this system of case manufacture required a great amount of thought, study and experimenting on the part of Mr. Thiery, and the company have spent a large amount in perfecting it. They claim under this method of manufacture to produce cases at less than one-half what it cost to make them in the old way. The machinery for doing the work is certainly novel in its way and reflects great credit on Mr. Thiery's mechanical ability.

JOHN F. SEREX.—SEREX & ROBERT.

John F. Serex came to this country from near Geneva, Switzerland, in 1850, at the age of 32, and after serving his apprenticeship in New York entered the employ of Rogers, Langdon & Went. He remained with them only about a year, and then formed a co-partnership with C. L. Thiery, who was then located at Cambridgeport, the firm becoming Thiery & Serex. They moved to Boston and started a shop on the present location of the Washington Building, subsequently removing to School street. They made both gold and silver cases for Swiss and English movements, and early began to make them for American movements. In 1860 they added steam power. After the concern moved to Harvard Place Mr. Serex dissolved partnership with Mr. Thiery, but remained in his employ for five years, until in 1869 he started in business with two brothers named Maitre at No. 8 Province Court, under the style of Serex & Maitre Bros. They subsequently moved to 7 and 9 Province Court and dissolved, the Maitre Bros. going out. In 1876 Mr. Serex admitted into partnership a workman named Desmaison, who continued for four years. In 1880 Arnold Robert was admitted, and the firm name of Serex & Robert was adopted. A dissolution took place recently, each partner continuing alone.

JOHN R. PROUD

Was born in East Greenwich, R. I., and served his apprenticeship with H. & D. Tarbox, importers and dealers, in New York, along in the thirties. He then entered the employ of H. & J. F. Pitkin, of Hartford, Conn., made the tools and appliances necessary for case making, and completed the first cases himself. He moved to New York with them in 1841. After the death of Henry Pitkin the other partner continued the case business, Mr. Proud acting as foreman. He subsequently went to Boston to work for Dennison, Howard & Davis, who were then trying to manufacture cases with but indifferent results. Mr. Proud increased the output from a dozen a week in 1855 to 200 a week in 1857. He then took Edward H. Owen as a partner and they commenced with the Waltham Watch Company and run the case manufacturing part of their business on a contract until 1861. He retired in 1867.

EDWARD H. OWEN

Was born in Gloucester, R. I., August 23, 1824, where he spent his early life. He worked for a time at locket making in Providence. Previous to this, however, he was employed for a year and a half in a factory to make spindles for mills. He entered into partnership with John R. Proud at Waltham in 1857, for the manufacture of cases, continuing with him until 1861, after which he was superintendent of the company's silver case shop for a number of years.

(To be continued.)



[FROM OUR SPECIAL CORRESPONDENT.]

A BIG BURGLARY.

BOSTON, Aug 19, 1889.

This has been a criminally eventful month. The professional burglar was in town and made off with his \$8,000 worth of plunder. Just where he or they are would be of interest to William B. Morse, dealer in diamonds, watches and jewelry, 268 Tremont street, near Hollis. The work was too skilfully planned and carried out to have been done by any mere amateur. The man or men were old hands at the business. So says every one who has seen the place—from inspectors at police headquarters down to the patrolmen. The time the job was done was probably between midnight and four o'clock in the morning. Morse's store, "The Gem," is located under a flat house. At night the most valuable of the jewelry is placed in a small safe standing next to the window, which by day is partially hid by a green curtain hung on a rod with brass rings. After the store is closed the light is left burning, and the screen is pushed back so that the officer patrolling the street has a good view of the safe and interior of the store. When Mr. Morse opened up the shop in the morning the curtain was pushed back against the partition and the gas was burning as when he had left the night before. The safe door was closed and everything was apparently all right. But in the safe door, between the lock and combination, was a hole a half inch in diameter. The door would open without regard to the combination. Inside all the trays that had been so carefully deposited the night before had been removed. The wood work under the show window had been broken out and replaced. An investigation showed that the trays and some of the jewelry were lying scattered around the cellar floor beneath the store, together with a dark lantern, a screwdriver and a bitstock. None of the silver watches were taken, they being thrown aside in the cellar, together with some plated watch chains and pins that were evidently considered of doubtful value. The jewelry taken consisted of 60 solid gold watches, 12 diamond pins, 12 diamond studs, valued at from \$10 to \$200 each, 12 pairs diamond ear rings, valued at from \$50 to \$500 per pair, six diamond bracelets, 50 diamond rings, valued from \$50 to \$250, a quantity of loose diamonds, some of which were to have been reset, and \$50 in cash. The store this morning presented an empty appearance, the thieves leaving about \$500 worth of stock. Mr. Morse's store was a small one, but he had the reputation of carrying very fine goods. The police think that they have a clue to work upon, but it is not of a very encouraging nature, however. Mr. Morse has been very unfortunate in having been robbed twice this year and once in 1886, when he had a store on Washington street which was burglarized and a couple of thousand dollars worth of stuff taken. He does not belong to the Jewelers' Security Alliance.

INSTALLMENT JEWELERS ORGANIZE.

As the outcome of an agitation among the jewelers of this city who do business on the installment plan, brought about by the necessity of mutual protection against that class of people who use the installment business as a means of replenishing their pocketbooks, 15 of the representative credit jewelers met in Wesleyan Hall and established a permanent organization, to be known as the Boston Credit Jewelers' Association. These officers were elected: A. D. Cairns was chosen President; W. S. Crown, Vice-President; W. B. Foster, Secretary; William Thompson, Treasurer. The President, Secretary, and Messrs. Henry W. Holbrook, C. Burgin and Henry W. Kinsport, Executive Committee. It was decided that regular meetings should be held on the first Monday in each month, and the annual meeting on the first Monday in April. The Secretary was

vested with power to open and operate an exchange in the central part of the city, and to engage the necessary clerical force. Each time a new customer applies for goods on credit his name, address and description will be sent to the exchange, and, if it is found on examination of the records that he owes some other firm or has been in trouble with any of the members, he will, of course, be refused credit. Should it be discovered that the intended purchaser has been defrauding the jewelers to any extent, the case will be put in the hands of a Pinkerton detective with orders to run the swindler to earth. Ultimately it is expected that the exchange will also be made a collection bureau.

Chas. A. Fernald has been arrested for concealing a \$77 watch bought of Clements & Co. on instalments.

Optician Wm. H. Edmands has opened a new and enlarged establishment at 43 West street.

Manufacturer Chas. M. Ward, at 409 Washington street, reports an exceptionally brisk trade.

There will soon be a new concern at 26 West street. It will be known as the Alexander Company, with a capital of \$25,000. James E. Alexander, long with Shreve, Crump & Low, is President, and Edward R. Barnes, late of Rand & Crane, is Treasurer.

A. H. Potter & Co., at 521 Washington street, have leased an extra store at Waltham.

A snatch thief recently robbed Jeweler Jacob Fainstein of \$74 at 229 Hanover street.

Jacob Lewis, of Tremont street, has gone into a museum enterprise with George F. Millbank, in Brooklyn, N. Y. Mr. Lewis will not, however, go out of his present business.

The instalment firm of H. E. Clement & Co., at 19 Milk street, has been dissolved.

Chas. E. Davis, at 7 Hanover street, was recently denied a discharge in insolvency.

Nelson H. Brown, the clock jobber, has been on a western trip.

Frederick W. Palmer, who once kept a jewelry store in Boston, and achieved notoriety in New York a few months ago, when he was thrown out of Theiss' concert hall by a waiter and sustained a fracture of one of his limbs and who was arrested at the Astor House recently, is well remembered here as a dashing man of fine physique and entertaining manners. His winsome ways have brought him into a good deal of trouble, and it is owing to his persuasive powers that he was taken into custody to answer a charge of having mulcted Mark Jacobs, a steamship agent, of 112 Canal street, out of several sums of money.

LEON.

CINCINNATI

[FROM OUR SPECIAL CORRESPONDENT.]

Cincinnati jewelers are feeling quite hopeful for the fall season. All through the Ohio valley, up through the middle lake states, and in Kentucky, Tennessee and the far south, in short, pretty much all over the region tributary to Cincinnati, crops are abundant and are already securely harvested. Travelers now out on the road are sending in good reports. Orders this spring and summer have been cautiously given so that now the retailer must stock up to prepare for his holiday trade. All these signs of promise are cheering to the Cincinnati jobbers and manufacturers and they are accordingly counting on a lively fall to compensate for the comparative quiet of the spring.

The "old reliable house" of Jos. Noterman & Co., 203 and 205 Race street, are very busy filling orders for their "Olympus" dia-

mond goods, and the other specialties of their manufacture. Their repairing department is also quite a feature of their business, and its steady growth is all the comment that is necessary on the style of work which they turn out.

W. S. P. Oskamp, of the wide-awake young house of Oskamp, Nolting & Co., 51 W. Fourth street, is in Amsterdam and the other diamond marts quietly securing the large stock of precious stones that the house will offer to the trade this fall. Mr. Oskamp, through his experience as buyer of the old house of Clemens Oskamp, is well fitted to satisfy the demands of the trade, who can rest assured that what he brings back will be right in kind and in price. He is expected back about the first of September and if you are wise you will be before hand and "catch him quick before the bargains are all gone."

Mr. John C. Dueber, of the great case and watch works, is frequently seen in this city on business. His family has not yet moved to their new home but expect to go soon. All who have inspected the new buildings at Canton are enthusiastic in praise of their vast extent and appointments, and the salubrity of the climate.

The elegant new store of A. & J. Plaut, 131 W. Fourth st., is now in perfect order. The window displays are attracting a good deal of attention.



[FROM OUR SPECIAL CORRESPONDENT.]

ATTLEBORO, August 20 1889.

News items in the jewelry trade are indeed scarce. The business in most cases is at rather low tide. The bright prospects which were so anticipated don't seem to materialize, and the manufacturers are still hoping for a revival of orders.

I expect that at the coming fair of the Attleboro Agricultural Association the jewelers of this section will again make a display of their products. It seems only right that in this especial fair of Attleboro there should be an exhibition of the one thing which has made Attleboro known all over the world. Last year, for the first time in many years, a general display was made, and the long cases with their novelties, representing the products of about all the large shops in this vicinity, were one of the most interesting features in the large exhibition hall. To the uninitiated this display reflected great credit upon the manufacturers, but those who know say that these same manufacturers exhibited the very oldest patterns to be found in their cases, as they were afraid their competitors would imitate them if they showed their new patterns. R. F. Simmons is president of this association, but as he is now in California on account of his health, Wm. M. Fisher, a well-known Providence jeweler and a leading member of the association, is attending to the duties of the office. In fact, one could go through the entire list of officers, and, with one or two exceptions, find well-known jewelers.

There is one firm in Attleboro who have had about all they could attend to thus far. I refer to W. & S. Blackinton, the well-known chain manufacturers. Sumner Blackinton was in town on business a few days ago, and it would seem that his firm have been peculiarly fortunate in getting out "taking" designs.

E. I. Franklin & Co. have moved their shop into the F. G. Whitney building, where they will find increased facilities for doing their work. The "Krementz Button" manufacturers are one of the liveliest firms in North Attleboro.

F. D. Heffron, the new traveling member of the firm of Riley, French & Heffron, has just returned from a very successful western trip.

In my last letter I said that in all probability the traveling public

would soon have a house to put up in when obliged to remain over night here in North Attleboro. Well, I was laboring under a delusion. The big "white elephant," otherwise designated as the Wamsutta House, is still closed, and likely to remain so for some time. The would-be proprietor was to take his lease only on the condition that the Board of Selectmen would grant him a license to sell intoxicating liquor, but this they refused to do and he left the town in disgust. So I say unto any of you drummers who may some time in the future be in danger of finding yourselves stranded on the inhospitable shores of North Attleboro, be sure you come in time to take the last train out, otherwise your only alternative will be the "hotel" run by our amiable deputy sheriff, Brown.

F. Mauser & Co., the silversmiths, have some elegant new designs in berry bowls, etc. They are going more extensively than ever into silverware, while preserving the same variety and excellence in their stock of silver novelties. A new pattern for a toilet set, which they have justly applied for a patent on, is likely to create considerable furor.

R. Blackinton & Co. report increased sales of their bright cut or brilliantine silver work.

J. G. Cheever & Co. are quite busy at present supplying orders for their reliable *J. G. C. & Co.* rolled plate chains.

At the factory of F. M. Whiting & Co., manufacturers of sterling silverware and silver novelties, everything is humming. This concern knows no dull season. They have been constantly getting out something new, until now the articles of their manufacture make quite a catalogue alone. Among the novelties for the fall trade, in addition to the "Marquis" pattern in flat-ware, illustrated elsewhere in this issue, are a variety of elegant designs in berry bowls and water pitchers, with scroll ornamentation and rich engraving.

Wade, Davis & Co., of Plainville, are constantly adding new ideas until their line is meeting the unqualified approval of all the jobbers. They have some of the most elegant and desirable goods they have ever produced, and the consequence is that orders are running far ahead of any season since 1883. They are receiving "duplicate orders," which really determines the appreciation of the trade, and from present appearances bid fair to keep the ball rolling.

MENDON.

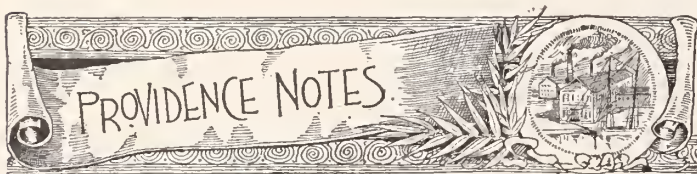

[FROM OUR SPECIAL CORRESPONDENT.]

PROVIDENCE, R. I., August 15, 1889.

The dullness during the past month has been more marked than at any time since the latter part of the spring season, and complaints are being heard on all sides. Very few concerns are being rushed to any great extent, and the prospects, to say the least, are not over encouraging for a heavy season's business, as some predicted earlier in the year. The great number of heavy failures of late and the unsettled state of the financial world seems to be impairing the confidence of the public, which is reflected in the present conservative state of affairs. During the present season, firms as a general thing have ordered as little as possible. Trade paper has again made its appearance to some extent in settlement of accounts, which speaks for itself in regard to the supply of available funds on hand in some localities.

Mr. C. Anthony Fowler and family will return home from Portsmouth, N. H., where they have been spending the summer, about September 1st.

The case of Hiram Howard against William S. Godfrey and others, for infringement of a patent button, was heard in the United States Circuit Court last Tuesday before Judge Colt. The defendants claimed that they were making the button long before it was patented, and that the plaintiff was not entitled to protection on the patent. By consent, however, the suit was discontinued.

The firm of Holden & Gardner has been dissolved by mutual consent, Chas. I. Gardner retiring. The business will be continued at the old stand by Robert B. Holden.

All persons who held claims against Mr. A. J. Robinson were given notice to appear on the 30th ult., before Mr. Walter F. Angell, Master in Chancery, in the cause in equity between Joseph B. Knowles, assignee.

The firm of Messrs. Godfrey & Adams, formed by Wm. S. Godfrey and Geo. E. Adams, with John C. Knowles as a special partner, has been dissolved by mutual consent, Wm. S. Godfrey retiring, and will be succeeded by Adams & Knowles, who will continue to transact business at the old stand.

Capt. Thos. W. Manchester, with Messrs. J. B. & S. M. Knowles, is about starting on a trip through the South and Southwestern States.

The estate of the late Alfred S. Potter, on Broad street, was sold at public auction on Wednesday, July 17th, to Mr. Jesse Metcalf, President of the National Bank of North America, for \$7,500.

Mr. W. S. Godfrey has commenced business again as Godfrey & Co. at No. 183 Eddy street.

Mr. Edwin Lowe was elected vice-president of the 1st Battery R. I. Detached Militia at Bristol on Monday last, at their reunion.

The Jewelers' Sick Benefit Association has elected the following officers: President, Mr. Albert Ohler; Vice-President, Carl Dahn; Secretary, Jacob Remlinger; Financial Secretary, Carl Monnier; Treasurer, John Mueller. At the semi-annual meeting it was shown that there are thirty-four members, and that the treasury contained \$786.67.

M. Chas. A. Fraser now represents the firm of Barstow & Williams throughout the West.

Mr. Hiram Howard, of the General Assembly, is spoken of as a possible candidate for the nomination of Mayor of this city by the Democratic party. He was one of the conference committee that framed the new liquor law which is soon to go into effect.

Alderman Edwin Lowe met with quite a painful fall from the porch of the Twin Mountain House at the White Mountains the past week, but is fast convalescing.

Mr. W. H. Luther, of the firm of Messrs. W. H. Luther & Son, has been appointed one of the new License Commissioners by Mayor Barker. The term is for two years, and salary about \$1,200.

The Admiral of the French Fleet (while his vessel was lying at Newport) visited this city as the guest of Gov. Ladd, and while here inspected the works of the Gorham Manufacturing Co., and was very favorably impressed with the magnitude of the works. He expressed great admiration, and has extended an invitation to the Governor to visit him at his home in France, which he will soon probably accept.

Mr. Charles F. Irons reports prospects to be very good for a steady business throughout the fall.

Messrs. C. A. Russell & Co. are quite busy in orders for their popular line of plated emblems.

Messrs. Fred. I. Marcy & Co. will soon place on the market their latest new collar button, which is named the "Eiffel" and should meet with instant favor with the trade generally.

Messrs. Davis & Emerson are doing a rushing business with their new solderless collar-button, the "Monarch."

Messrs. Foster & Bailey have their new patent locket about ready to place on the market, and it leads anything in that line for novelty and beauty. Their "Mount Hope" sleeve button holds its own with the trade against all comers.

Mr. Charles Downs has one of the largest and most complete lines of umbrellas and cane heads to be seen in the samples of any manufacturer, and says business is booming.

FAIRFAX.

The Chicago Horological Institute.

ITS ORIGIN, GROWTH AND PRESENT ATTAINMENT.

Origin of the Idea.

The Chicago Horological Institute, incorporated August 22, '88, has grown, in the short space of one year to occupy a leading position among the horological schools of the country. In August, '88, realizing the need of such an institution, where the present and coming workman could receive the highest practical and technical instruction to be had, Mr. Urban W. Frink and Mr. O. C. Jaquith, two acclimated yankees imbued with typical western push and enterprise, after living in the West and becoming imbued with the progressive spirit so manifest there, saw that the time was ripe for the successful establishment of a horological school of this character. So with their hearts in the work, and faith in its ultimate success, they took the first step by incorporating as the Chicago Horological Institute, under the laws of the state of Illinois, so that any of its friends who felt disposed to, might leave bequests to the Institute, the income from which would support one or more free scholarships for indigent students, who might wish to learn this trade, but could not owing to a lack of necessary funds. Upon receiving their charter, they leased one small room with a smaller one opening out of it, to be used as an office, at 175 Dearborn St., one block above their present quarters.

Early Difficulties.

Their hardest work now was to procure the proper man for first instructor. This they at last succeeded in doing in the person of Mr. R. E. Fenner, who then had a lucrative position, which he was loth to leave, but which, after careful investigation of the merits of the new enterprise, he concluded to surrender and enter the new and then untried field of horological instruction in Chicago. He had this for a reason, that his faith had been confirmed, not only in the enterprise, but in the ability of its promoters to sustain and push it to a crowning success. With his services secured as watchmaking instructor, it was then necessary to procure an engraving expert as instructor in this latter branch. To fill this position, they secured



VIEW OF OFFICE.

the services of Mr. J. B. Wiggins, one of the oldest and finest engravers in the West, a man who had a large experience in the teaching of his art to young men. The next step was to procure lathes, benches and foot wheels, taking care that everything should be of the best and latest pattern, and that their equipment should be complete in every detail. Then two benches, each fifteen feet in length, with a set of drawers for each student, were procured with six Grouts foot-wheels, and they were ready for business.

The First Student.

Two months had elapsed, yet not a student had, as yet, materialized, when on Oct. 24th, 1888 they received a matriculation card duly filled out, with money order for \$10.00 enclosed, as entrance fee of Mr. L. E. Winslow of Presque Isle, Maine, saying that he would enter the school January first. This was the first student. They then began to redouble their efforts to obtain students. In November, Mr. G. H. Batchelder from the La Porte school paid them a visit and was so much impressed with the showing of



INTERIOR OF WORKROOM A.

this school that he made up his mind that it was the place for him to attend, and accordingly, in December, entered the school as its first working student. His is the handiwork illustrated in this month's CIRCULAR, being a 16 size pocket chronometer, completed by himself after January first, 1889. This month, January, '89, Mr. Winslow appeared and was the second student, being followed by six others, and not a month has passed since without showing a healthy increase in the attendance of this constantly growing school, which became so large in April that the managers commenced to look around for larger quarters, as it was evident that the school had then become a success and they must have more room to accommodate the students.

The school now numbered thirty students, taxing the capacity of their location to its utmost.

Equipment.

During this time they had added to their plant in the way of lathes, benches, foot wheels, etc., as fast as the growth of the school required, using the Webster-Whitcomb lathe No. 2 in connection with the others, so that the different preferences of the students could be suited.

To New Quarters.

After a long and tedious investigation of the different sites deemed suitable for the school, they decided upon the new Owings building, then in process of construction, at the South East corner of Dearborn and Adams Sts., one block south of where they were then located. Here they ascended to the eleventh floor and increased their quarters to five rooms, which are used as follows: On the left, as you leave the elevator, you enter the office, which is neatly fitted up with every convenience for the dispatch of business. It also contains a large vault for the safe storage of watches sent in by jewelers, from all

parts of the country to be repaired. This item of trade work soon became such an important matter that it was necessary to engage a young lady to look after it and see that it was properly entered upon its receipt, and duly shipped when done. The receipts from this source are divided with the students. Her other duties are to check out the tools to the students and to answer the correspondence, which she takes down in short-hand from dictation by the managers, their mail having attained such proportions that it was impossible to answer it all by hand writing. In the office, for the purpose of answering the letters, they put in a new No. 2 Remington typewriter, so that all their mail shows the same neatness, and general character of discipline, to be found throughout in this model school.

System and Arrangement.

Here also is located the large tool cabinet, with glass doors, containing all chucks and attachments used by the students. Each student is provided with a set of checks with the number of his bench thereon, and if he wishes any tool, he steps to the opening in the window, and hands in his check corresponding to the required tool. This is immediately given him, and after using, he returns it to the office, taking back his check therefor. In this way all the tools are accounted for, and here again is shown the excellent system that the management have sought to introduce in the school.

Leaving this room we are ushered into the instructors' private

benches, occupied by students in the pursuit of their watchmaking studies. From this room, passing through the door, we enter room B. It is as large and similarly equipped. Here also one sees the same sight of busy students, filing, turning, jewelers, and doing all the different kinds of work that one would expect to see in an institution of this kind.

From this room, we are led into the laboratory, equipped with its heavy benches, vice, anvil, bellows, and automatic blowpipe, overhead of which is a large smoke main for taking off the gas and acid fumes and allowing perfect ventilation. In this room students are required to do all their heavy filing, tempering, forging, hammering, etc., etc.

In room B, there have just been added two large oak cabinets, of handsome workmanship, for the reception of the students' hats and coats, containing apartments numbered to correspond with each student's bench and check.

The cuts we show with this article give a good general idea of these rooms. For correct time, in room A we find a magnificent mercurial four jar pendulum Howard regulator. In room B is a clock worked by electricity, which is set to the fraction of a second every hour, by the master clock in the office of the Western Union Telegraph Co., on the corner of Washington and La Salle streets.

Familiar Talks from Visitors.

The school was favored, in the spring, while yet in their old quarters, with a call from Messrs. Logan and Duncan, of the Waltham Co. The evening was devoted to a general talk to the students, by these gentlemen, in which the general properties of model and escapement magnetism and the general outline of factory work as accomplished at Waltham were shown. When Mr. Logan returned to Waltham, he remembered the Institute by presenting it with a millimeter gauge of most accurate workmanship which measures to the one-ten-thousandth part of a millimeter; also a watch heater for the adjusting of watches to heat, used in connection with the large ice-box in the laboratory, for adjusting purposes.

Number on the Rolls.

The school now numbers about forty students, which with present applications, will raise it to nearly sixty by January 1st. This will necessitate the occupancy of the entire floor, which will double their present capacity.

To give our readers an idea of the wide fame this institution has already acquired, it is only necessary to say that they have students in their school from St. Petersburg, Russia, one from England, one from Ecuador, S. A., while nearly all the different states and territories have contributed their share to the Institute.

The work done by the students in this institute is commendable for its finish and accuracy, and the manifestation of the thorough teaching they receive. Being situated as they are, their advantages are at least equal to those of any other school in this or in the old world, and we look to Chicago to foster this institute and make herself a center of horological instruction in this country. We look to the management for the same enterprise in the future as they have exhibited in the past, with a keen eye to the wants of the students and a quick response to the same, ever keeping in mind that to maintain the high character they now have, they must ever be on the alert, and be careful that no diplomas are granted to students who are unworthy of them.

Painstaking, thought and study, and great expense were necessary to establish and maintain a school of this kind.

Their endorsements in the trade are sufficient guarantee of the ability of the management and the instructors employed, and we would sincerely advise those who contemplate taking a course of instruction in a horological school, to give this a thorough investigation.



STUDENTS AT WORK, ROOM B.

office. Here can be found Mr. R. E. Fenner, Mr. J. B. Wiggins, engraving instructor, and Mr. K. Einsiedel, a recent acquisition as second instructor, coming to this school. May 1st, from Grossman's School of Horology at Glashütte, Germany. His services were obtained about four weeks previous to the occupancy of their new quarters, the school having grown to such a size that it was impossible for one instructor to give the students the painstaking attention that the management was seeking to have each student obtain.

The Draughting Room.

In the instructors' private room we find the draughting tables and all the paraphernalia for the giving of theoretical instruction. Here the student is taught to draught a complete watch and everything contained therein, from the main wheel, with its coarse teeth, to the most minute escape wheel and tiny pallet.

The Workrooms and Laboratory.

We then enter the long workroom A, filled with long rows of

Neglected Problems.*

MEASURING THE WHEEL AND PINION DEPTHS.

BY "EXCELSIOR."

ONE of the most important points for the watchmaker to attend to is the correct action of the wheels and pinions in transmitting the motive power from the mainspring to the escapement. As this subject has not been so thoroughly treated by writers as it might have been, a short practical article, as free as possible from technical terms, will doubtless be welcomed by most workmen.

We read that by observing the action of the tooth upon the pinion leaf which it drives, we may know whether the wheel and pinion have the correct proportionate sizes to act properly together, and whether they are so placed in the watch as to work into each other the proper distance or depth. To some extent this is true. The watchmaker can tell whether they engage to the proper depth, *i. e.*, whether the depthing is correct, and the expert workman can judge pretty closely whether the pitching is correct, *i. e.*, whether the wheel and pinion have the correct relative diameters for each other. But all workmen are not experts, and consequently all cannot properly test the pitching in that way. Besides, in mechanical matters, no method of estimating or guessing at sizes is quite equal to actual measurement of the parts, and that should be resorted to whenever there is any uncertainty.

A wheel may have its teeth properly formed, and work the proper distance into a pinion whose leaves are also properly formed, and yet the two may be utterly unsuited to act together, because their relative sizes are not correct. Even when this error is considerable, the points of the teeth may be rounded in such a way as to avoid catching on the leaves, and to the average workman, following the usual rules, there would appear to be nothing very serious the matter, and yet the excessive friction and improper arrangement of the parts may actually stop the watch.

There are a good many ways in which the sizes may be incorrect. The wheel and the pinion may both have the correct sizes, relatively to each other, but their jewel holes may be too close together or too far apart; in the former case, both wheel and pinion would be too large, and in the latter case too small, for their position in the watch. The wheel may have the correct diameter, while the pinion is too large or too small for it; or the pinion may have the correct size for the distance between the pivot holes, while the wheel is too large or too small. Both wheel and pinion may have diameters unsuited to each other and to the distance between their pivot holes, the former being too large and the latter too small, or the reverse.

Any of these errors, or their absence can be detected by measuring the distance between their pivot holes, and then ascertaining, first, whether their diameters have the same ratio to each other as the number of the teeth and of the leaves; and second, whether the semi-diameter or radius of the wheel added to the radius of the pinion just equals the distance between the centers of the pivot holes.

For instance, if the wheel has sixty teeth, and the pinion it works into has six leaves, then their diameters should have the same proportion, *i. e.*, the diameter of the wheel should be ten times that of the pinion; and, having those proportionate sizes; their combined semi-diameters must just fill the distance between the pivot holes. Consequently, if you measure that distance accurately, and divide it off into eleven equal parts, the radius of the wheel must be equal to ten of those parts, and the radius of the pinion must equal one part. Or, the diameter of the wheel must equal twenty parts, and that of the pinion two parts. If either the wheel or the pinion varies from that, you may know that it is wrong. There is no guess-work or opinion about it, but it is a certainty.

We read that if the parts are of incorrect sizes, it is better that a certain part should be too large, than the other one; and that in trying to improve an imperfect depthing, when we cannot make it correct, we should make such changes as will leave the former part

too large and the latter too small, rather than the reverse. With regard to that I shall have nothing to say. This article relates to the method of ascertaining whether the parts are correct, or what the error is. What the workman shall do to correct the error, is another subject. His course is often governed by circumstances, which may compel him to take one, when another would secure a better result, but is forbidden by considerations of expense or time. I shall show him how to ascertain the condition in which the parts are and that in which they should be, and leave him to act his own pleasure about making them so.

The diameter of a part is its pitch diameter. In considering depthings, the diameter of a wheel is not its total diameter, from the tip of one tooth to the tip of the tooth on the other side of the wheel, nor is the diameter of a pinion the distance from the tip of one leaf to the tip of the opposite leaf. Depthings are calculated as for wheels and pinions without teeth, or as simple circular parts or rollers whose surfaces roll upon each other. But as such rollers would slip badly, we make projections upon them, those of the wheel resting against those of the pinion, and so revolving the pinion without slipping. We also make hollows in each part, for the projections of the other to pass in, without catching. The diameter of the roller, disregarding the projections and the hollows, is the geometrical or true diameter of the wheel or the pinion; and, if we draw a circle having that diameter, that is its pitch circle, having its pitch or geometrical diameter. Of course, from the center of this circle to its circumference is the semi-diameter or the geometrical "radius" of that wheel or pinion.

Teeth and leaves. The projections spoken of are outside of the pitch circle, and the hollows inside of it. A projection with a hollow on each side of it is therefore what we call a tooth of the wheel or a leaf of the pinion, as the case may be. But the *acting length* of a tooth or a leaf, as a lever transmitting power, ends at the point where the pitch circle is. Inside of the pitch circle the sides of the tooth or leaf are made straight and in line with the center of the wheel or pinion; but outside of the pitch circle they are rounded off according to certain rules. We may call the straight-sided part of the tooth or leaf (inside of the pitch circle) its body, and the projection or rounded part its point.

Tooth points act as bent levers. When the wheel drives the pinion, as is the case in ordinary watch trains, the projections on the wheel, or the points of the teeth, are (or should be) shaped according to the mechanical "law of bent levers," so that when the extreme point of the tooth is pressing against the pinion leaf the wheel exerts the same mechanical pressure upon the pinion that it does when the pitch circle of the tooth presses against the leaf. The distance from the center of the wheel to the point of the tooth is greater than the radius, and the point touched by the tip of the tooth is inside of the pitch circle of the pinion, and therefore its distance from the center is less than its radius, and yet the mechanical pressure is the same as if the two pitch circles were in contact. I cannot now stop to explain how two levers, acting upon each other, can thus have their lengths changed, one being made longer and the other shorter, without affecting the power transmitted by them. But strange as it may appear to the workman, such is actually the case. I have said so much on this point in order to impress upon his mind the fact that no matter what the position of the tooth and leaf may be during their engagement (after passing the line of centers), the mechanical, acting diameter of the wheel or the pinion is the diameter of its pitch circle, and that diameter is the one to be measured.

In measuring the diameter of a wheel, we measure its pitch diameter as follows: Selecting two sound and perfect teeth exactly opposite each other, *i. e.*, at opposite ends of a line passing through the center of the wheel, we mark on the under side of each one where the straight sides meet the rounded parts or points, as closely as we can see with the eye-glass—making the mark a trifle too near the center of the wheel rather than the reverse. Then measure the distance from the mark on one tooth across to that on the other and you have

*Copyright, 1889, by The Jewelers' Circular Publishing Co.

its pitch diameter. Take this distance with fine needle-pointed dividers or calipers and set it off on a finely-divided scale; then one-half of it is the radius of the wheel.

In measuring the diameter of a pinion we proceed a little differently. The points of pinions are generally rounded off in circular form, *i. e.*, as a semi-circle set on the body of the leaf. Consequently, the width of a point at its base is twice its height above the pitch circle, or equal to the height of two points. We therefore measure the outside diameter of the pinion, from the tip of one leaf across to the tip of the opposite leaf; then measure the thickness of one leaf at its broadest part; deduct this (the height of two points) from the total diameter and you have the pitch diameter. When the number of pinion leaves is uneven make proper allowance in measuring the total diameter. Half of the pitch diameter is the pinion radius.

For measuring the distance between the pivot holes we need what are called vertical or pump dividers, because the measuring points are on pump centers, sliding parallel with each other and with the handle or body of the tool. One center is held in a stationary hole, the other in a sleeve movable along a three-sided bar at right angles to the body of the tool, like the lower part of the letter L. The stationary center is placed in one pivot hole, and the other is moved along the bar to come into the other hole. The sleeve is then fastened in position by a screw. When this tool is held vertically to the plate, the centers, being held truly tapering to points, will rest centrally in the pivot holes, no matter what the sizes of the holes may be, and show the distance between their centers or "center distance."

We do not want to know the actual distance between the holes in the movement, but the distance between the center or axis of the wheel and that of the pinions when held in their pivot holes, *i. e.*, what the distance would be if the holes were all on the same level. The third wheel hole may be $\frac{3}{8}$ inch below the center wheel hole. We therefore place one center of the tool in the center wheel hole, then slide the other center out until it rests properly in the third wheel hole while the tool is held vertically to the plate and the movable sleeve is screwed fast. Leave the movable center just loose enough to be moved by gentle pressure. Then rest the tool vertically on a flat plate of hard brass, and press it down gently till both points touch the plate, when they will be in the same plane and show the distance between the axes of the two parts when in their holes. Now, fasten the movable center and transfer the two points to a scale to ascertain the distance between them in thousandths of an inch, or any other measure preferred. There is a scale marked on the three-sided bar, but a separate scale is generally finer and better. In case of necessity, a depthing tool, with its sliding centers, may answer instead of the dividers.

Examples. In order to avoid calculations and make these examples as plain and simple as possible, we will suppose our measurements are taken in hundredths of an inch, but in practice the watchmaker should work to thousandths of an inch. Our center distance, measured as before described, is, say, 49 hundredths of an inch. To save repetition I will hereafter omit all but the number, and call the center distance 49. On counting the teeth and the leaves they work into we find 48 teeth and 8 leaves, which is 6 to 1. The diameters are always in the same proportion as the numbers of teeth and leaves, so their diameters should also be as 6 to 1. Therefore our center distance must be allotted to the wheel and pinion in the proportion of 6 parts wheel radius and 1 part pinion radius. There being 7 parts, when they are added, and the center distance measuring 49, one part equals 7 measured divisions on the scale. Consequently, the pinion radius should be 7 and its diameter 14, and the wheel radius should be $6 \times 7 = 42$, and its diameter 84 hundredths of an inch.

Example 1. On measuring, we find the pitch diameter of the above mentioned wheel to be 86 and that of the pinion to be 14. Therefore the pinion is correct, because its radius is one-seventh of the center distance, but the wheel is too large.

Example 2. The wheel measures 87 and the pinion 12 in pitch diameter. The wheel is therefore too large and the pinion too small.

Example 3. The wheel measures 82 and the pinion $13\frac{1}{2}$. Here they are well proportioned to work together, the wheel being very close to 6 times the diameter of the pinion, but they are both too small for the center distance, producing a very shallow depthing.

These examples show how easy it is to be certain whether the sizes are correct, and if not to know precisely where and what the error is. By counting the teeth and the leaves they work into you learn what proportion the pitch diameters of the wheel and pinion should have been to each other. Then by measuring the center distance and dividing it up in that proportion, you find precisely what the semi-diameter of each part should be. Lastly, by measuring the parts you ascertain whether their sizes are what they should be, and if not, how they vary from correctness, *i. e.*, whether they are too large or too small, and how much.

It is, of course, more trouble to do this than simply to look at the parts when running, and judge of their correctness by the way the teeth meet and act upon the leaves. But, as before stated, such inspection is not always satisfactory. It is comparatively easy to see whether the parts work into each other to the proper depth, if the points of the teeth are properly shaped, but if they are not so, or if they have been tinkered at, it is often difficult to tell any more than that the action is not right. For ordinary examinations inspection may do. But when there is known to be some trouble in the depthing and whenever the workman is uncertain about its correctness, the method by measurement should be followed. It is also good exercise for the young workman to examine the depthings of a movement by inspection, and then test the correctness of his conclusions by measurement when taken apart. This will not only positively determine the condition of the depthings, but will also educate him to know the meaning of what he sees in his inspections. When he has discovered an error he should put the parts in their places, and again observe the action which results from that error until he is familiar with all of them.

The Jewelers' and Tradesmen's Company.

GILBERT T. WOGLOM, *President.*
 THOMAS A. YOUNG, *1st Vice-Pres.* EPHRAIM S. JOHNSON, JR., *Sec'y.*
 SHUBAEL COTTLE, *2d Vice-Pres.* SAMUEL W. SAXTON, *Treasurer.*

BOARD OF DIRECTORS.

JAMES A. SMITH, M. B. Bryant & Co.
 EPHRAIM S. JOHNSON, Treasurer, E. S. Johnson & Co.
 SAMUEL W. SAXTON, President Solid Link Chain Mfg. Co.
 CHARLES A. FOWLER, Fowler Bros.
 JOHN C. DOWNING, Downing & Keller.
 SHUBAEL COTTLE, President S. Cottle Company.
 THOMAS A. YOUNG, Ex-President National Association of Commercial Travelers;
 Chairman Legislative Committee and Vice-President of the Commercial Travelers'
 Ass'n, State of N. Y.; President Traders' and Travelers' Union.
 SAMUEL F. ROBERTS, M. D., *Medical Director*, 69 E. 54th St., N. Y. City.
 SAMUEL A. BALDWIN, W. E. White & Co.
 GILBERT T. WOGLOM, Gilbert T. Woglom.
 WILLIAM B. KERR, Kerr & Battin.
 SAMUEL SONDEHEIM, Bruhl Bros. & Co.
 Counsel, JAMES M. HUNT, (of Rudd & Hunt) 31 & 33 Pine Street.

During the past month the following named were admitted to membership: Maurice Weil, Richard S. Pennock; Joseph Sherman, Jr., Gorham Mfg Co.; Richard T. Supple, Keller & Untermeyer; Peter F. Kayser, Frank E. Idell, William H. Jennings, Edward T. Denning, with Theo. B. Starr; Harry V. Freund, Victor Freund & Son; Geo. R. Collis, with Whiting Mfg. Co.; Nathaniel L. Cannon, with S. Cottle Co.; William A. Bryant, with M. B. Bryant & Co.; Henry G. Alford, of Alford & Lucas; all of New York City, and Joseph Winton, P. B. Levy, Newark, N. J.; Aaron R. Vanderbilt, Amsterdam, N. Y.; Samuel C. Tappin, Troy, N. Y.; Charles E. Richards, with Geo. H. Richards, Jr. & Co., Boston; Robert C. Parsons, Derby Line, Vt.; Albert H. Peacock, Dallas, Tex.; Henry G. Peirsons, with F. W. Sim & Co., Troy, N. Y.; Elijah J. Pring, Watrous, N. Mex.; John Nevin, M. D., Jersey City, N. J.; Charles L. Nicholson, Brooklyn, N. Y.; Willis B. Musser, Bowman & Musser, Lancaster, Pa.; Cornelius, G. Lockwood, Port Jervis, N. Y.; James Lawrence, Fream & Lawrence, Brooklyn, N. Y.; Leonard Krower, New Orleans, La.; George R. Kroher, St. Louis, Mo.; Christopher Klaus, Brooklyn, N. Y.; Menzo E. Baum, McGrawville, N. Y.



TRADE GOSSIP.

—Andrews & Doty is the name of a new firm of diamond brokers at 182 Broadway, New York.

—The August 18th issue of the *Hartford Globe* contained a lengthy article descriptive of the new quarters of A. F. Springer, at 32 Asylum street, that city.

—G. M. Thurnauer, of 66 Reade street, New York, importer of faience and bric-a-brac is, owing to a change of business, selling off his large stock at very reduced prices.

—David Untermeyer, of Keller & Untermeyer, Corbin building, New York, after a four months' sojourn on the Continent, arrived from Europe on August 3d. During his trip he visited, among other places, London, Paris, Amsterdam and Geneva.

—Pinnell, May & Co., watch case manufacturers of Newark, N. J., have placed upon the market a light 14-karat case that is meeting with much favor. Though very light in construction (and correspondingly cheap) in strength and durability, it approaches an 18-karat case.

—Sartorius & Co., of 28 Barclay street, New York, carry the largest stock of enamels in this country. They also keep a line of special colors for painting on enamels, ordinary colors not answering for enamel painting. Artists' brushes and Winsor & Newton colors are largely dealt in by them.

—H. E. Beguelin, of Cross & Beguelin, 21 Maiden lane, New York, returned from Europe on August 4th by *La Bretagne*, looking all the more hearty and contented for his three months' trip. During his sojourn he secured, among other attractive lines, a large and choice assortment of precious stones.

—H. J. Woodside, who for the last nine years had conducted a jewelry business in Portage la Prairie, Manitoba, has disposed of his business to McCullagh & Rost, and will hereafter devote his attention to the interest of *The Liberal* of that town, of which he has been managing editor for some months past.

—E. A. Haldimann, 3 Maiden lane, New York, reports that the imported "Bridgeport" movement, for which he is agent, is being received favorably by the trade. As a good and yet low-priced movement, Mr. Haldimann considers it to be the best in the market. These movements are made to fit silveroid key cases especially.

—Handsome and extensive (undoubtedly the most extensive in the trade) is the stock of rings that J. B. Bowden & Co., Corbin building, New York, have prepared for the coming season. Twist wire, rope, serpent and other novel rings with diamond, ruby, emerald and pearl combinations are shown in abundance, all uniquely and attractively designed.

—A class in optics at Dr. A. C. Bucklin's school, 206 West Forty-second street, New York, will form for September 10th. The course of optical instruction at this school is, without doubt, one of the most practical and thorough given by any such school in America. Letters are received daily from students who are pursuing or have pursued the course, and who feel it a duty to announce the success they are meeting in the optical trade.

—William F. Nye is daily the recipient of voluntary testimonials commending the excellent qualities of his famous watch and clock oils; those from the principal watch factories, Waltham, Elgin and Non Magnetic of America, being of particular value. Probably the severe cold test of from 24° to 30° below zero, to which Mr. Nye submits his oils in their preparation at his St. Albans refinery, is one of the operations in their manufacture that rendered them so superior.

—About 18 months ago, George Elliot & Co., wholesale opticians, of London, established an American agency at 38 Maiden lane, New York. Their branch office has proven successful and has firmly taken root. The specialty of this firm is the "aqua crystal spectacles" which they claim has many advantages over other makes. The firm are advertising them extensively by means of interesting pamphlets which they distribute to opticians in large quantities. These pamphlets are also sent to dealers with their own advertisements printed upon the covers. Elliot & Co.'s repairing shops are very extensive and only the most skilled mechanics are employed. The firm guarantee to return oculists' prescriptions the same day as received. We advise those in the optical trade to write for their book and particulars which are furnished free of charge.

—The pedestrian on Maiden Lane scarcely ever passes the show window of Stern & Stern without casting admiring glances to the display made therein. The semi-circle of bright diamond jewelry in light blue plush cases makes a charming effect which is enhanced by the surrounding mirrors.

—The *Annual Supplement* of the *Constitution Democrat*, of Keokuk, Iowa, is a commendable issue. It contains very creditable illustrations of the city's public buildings, churches, schools and parks, factories and principal stores, and residences, besides portraits of public officials and prominent business men. T. R. J. Ayres & Sons and Ayres Bros., the former doing a prosperous jewelry business and the latter conducting a good trade in musical instruments, are represented.

—Albert Berger & Co., 47 Maiden lane, New York, sole manufacturers of the celebrated "W. B. & C." watch glasses, have their store filled to its utmost capacity with their numerous lines in readiness for the fall trade. The glass or raw material of the "W. B. & C." glasses is of their own make and its great characteristic is its elasticity which has been so much admired by watchmakers. Their stock of lenses is extraordinarily large, and they can display over one hundred and fifty different styles of spectacle and eye-glass frames in gold, silver, steel, nickel, zylonite and rubber.

—The desire among the fair sex for miniature brooches borders upon a craze. To meet this demand the factory of John A. Riley, 860 Broadway, New York, is turning out large quantities of these goods with imported paintings beautifully mounted in 14-karat gold borders, in Florentine and other styles. They are made in assorted sizes. Mr. Riley is also busy preparing extensive and handsome lines of bead-necklaces which are also, at present, extremely popular. They are made in both gold and silver, with one to seven strands, and with regular-sized or graduated beads.

—The Middletown Plate Co., Middletown, Conn., have just issued a supplement to their previous catalogues, which illustrates a number of their new designs for 1889 in tea sets, in embossed, satin or plain finished, satin bright cut and burnished designs; urn sets in similar styles; swing kettles, tête-à-tête sets, coffee sets, waiters, water sets, cake baskets, preserve or berry dishes, jelly dishes, nut bowls, dinner and salad casters, desert sugars and creams, bureau boxes, baking dishes, cups, chocolate pots, pickles, celeries, salt and peppers, napkin rings, rose jars, wine coolers, mirrors, brushes, candelabra, and a host of other articles, all in several styles of decorations and in a variety of designs. This supplement as well as photograph albums will be sent to dealers upon application. All these new designs can be inspected at the company's salesrooms in New York, Chicago and San Francisco.

—An enumeration of the different articles that the Bradley & Hubbard Manufacturing Co. have prepared with a view to their adaptability to the jewelry trade, would occupy too much space. Suffice it to say that the visitor to the company's show rooms at 26 Park place, New York, can expect a large variety of extension piano and banquet lamps elegantly designed in silver finish, brass, bronze, copper and wrought iron, some having Mexican onyx ornamentations; a fine line of table lamps in plain and oxidized silver finish, copper bisque cameo, all the lamps having the celebrated B. & H. burner; bronzes of medium to fine qualities; onyx tables with metal legs and mountings; five o'clock teas, the stands being in silver finish or wrought iron, while the kettles are of copper; bronze, silver and metal pitchers, vases, candelabra, pedestals, sconces, mirrors, clock cases having imported French movements, handsome candlesticks in copper, silver, etc., easels and a host of small wares in metal, new and uniquely designed.

—A very remarkable line of imported goods consisting of clocks, bronzes, porcelains, pottery, cabinets, etc., is displayed at the salesrooms of Leon J. Glaenger, 80 Chambers street, New York. Four spacious floors are filled with new goods just received from France; the first floor is devoted mainly to clocks, and we notice handsome designs in marble, porcelain, Mexican and California onyx, the latter having the appearance of tortoise shell, and being very handsome; an extensive assortment of imported carriage or traveling clocks. In the three upper floors the visitor can inspect an enormous assortment of new bronze figures and combination white bisque busts, Baccarat cut glass in candelabra, lamps, water pitchers, etc.; sets of French desert plates (of which forty dozen are in stock) in various designs with hand-painted figures excellently executed; a large variety Vernis Marten fancy tables and cabinets with unique shapes and hand-painted tops, Dresden bric-a-brac, Sevres porcelain, elegant cabinets, etc. Many of the pieces are duplicate of articles now at the Paris Exposition, the originals having been bought by Mr. Glaenger.

—E. Holbrook, of the Gorham Mfg. Co., arrived from Europe on August 2.

—Isaac Valentine has re-entered the employ of F. Jeandheur, Jr., the plater and colorer.

—George A. French, representing Wm. S. Hedges & Co., diamond importers, sailed on his annual European trip on August 3.

—Lord & Lowell, Augusta, Me., have disposed of their branch store at Winthrop, same State, to W. C. Bailey, who will continue the business.

—Dr. Leonard Waldo, formerly of the Yale Observatory, has accepted the office of electrical engineer of The Aluminum Brass & Bronze Co., of Bridgeport, Conn.

—Theo. Evans has accepted the position of Western salesman for Hodenpyl & Sons, importers of diamonds and manufacturers of jewelry, 170 Broadway, New York.

—Cattelle & Decker, of 24 Maiden Lane, New York, have produced for the fall trade a very large line of silver novelties, embracing almost every article for ornamental or boudoir use.

—Jacob N. Bonnet, successor to the firm of Mulford & Bonnet, left for Europe on the *Servia* on the 10th for a short business trip. Mr. Bonnet expects to return by the first week in September.

—A pretty advertising conceit is being issued by the Dueber Watch Case Mfg. Co. It is a little circular looking glass, at the back of which is the familiar gladiator embossed in white upon a blue ground.

—C. P. Murphy, Newcastle, Ind., has removed to the store formerly occupied by W. G. Hillock, which he has fitted up in elegant style. The present location gives him more room and affords better facilities for business.

—H. F. Barrows & Co., North Attleboro, Mass., the trade-mark of whose plated chains is the well known "H. F. B.," a trade-mark which is esteemed by the jewelry trade as thoroughly reliable, are on hand this fall with a fine selection of patterns.

—W. & S. Blackinton, the chain manufacturers, are again on deck with a new chain, for which they have secured a new trade-mark, "The Star and Crescent." It is made in a great variety of styles, and is known among the trade as "The Crescent."

—L. Newman, Jr., gold and silver plater, of 36 John street, reports business to be satisfactory for this season. Orders for Etruscan and heavy coloring on gold constitute his principal demands, although importers still send lines of watch cases for plating.

—Nicholas Muller's Sons have in preparation for the coming season an attractive stock of top and side ornaments for clocks. Bronzes, lamps, &c., &c., in bewildering variety, fill the shelves of their extensive store at 117 Chambers street, New York.

—The Acme Silver Plating Company, Boston, Mass., have taken a ten years' lease of a building at Boylston Station, and purpose giving up their quarters in Beverly street. The company will occupy the whole three floors, as they are doing a steadily increasing business.

—Chas. R. Williams, formerly with the Chas. D. Pratt Co., importers of jewelers' fancy goods, has connected himself with the house of Schneider, Campbell & Co., Union Square, New York, manufacturers and importers of artistic gas fixtures, bronzes, onyx clocks, pedestals and marbles.

—Finding his present quarters too small for his growing trade. W. L. Whedon, York, Neb., has leased the Savings Bank Building, which occupies one of the best business corners of the town. Improvements to be effected in the new store will make it one of the handsomest of its kind in the state.

—The Wm. Rogers Mfg. Co., silverplated ware manufacturers, of Hartford, Conn., are reported to be negotiating for the purchase of the plant of the Wickersham Horse Nail Company, Norwich, Conn., with the intention of using it largely for the production of steel blanks of which they are a large consumers.

—Stern Bros. & Co., 30 Maiden Lane, New York, have purchased a thimble manufacturing plant, and have transferred it to their spacious factory on Gold street, where, in addition to their large line of set, plain, filled and initial rings, they are manufacturing and have now ready an attractive line of gold and silver thimbles.

—A. N. Clark, the well known manufacturer of watch keys, Plainville, Conn., reports a flourishing trade and orders ahead. The productions of this manufacturer have met much competition, but they have retained their good reputation and steady demand. Especially is this the case with his loop watch key, which is regarded by the watchmakers of the country as one of the best keys for the small price produced in this country.

—The "Princess Louise" bracelet is the latest evolution from the fertile ingenuity of Henry C. Haskell, Corbin building, New York. It is a continuous band of sterling silver, made to slip over the hand and up and down the wearer's wrist. The patterns are handsome, some being satin finished, others plain, oxidized, chased or engraved. The bracelet sells at sight and is becoming very popular. Mr. Haskell will be pleased to forward samples to any dealer who has not seen it.

—The lines prepared for the coming busy season, displayed at the New York office of R. Wallace & Sons' Mfg. Co., 23 Park Place, is being admired by all visitors. In children's knife, fork and spoon sets, the assortment shown is wonderful in its variety. In match-boxes, over one hundred patterns and styles are carried. Glove buttoners, button hooks, nut picks and a host of other desirable things, are well worthy an inspection.

—The Rockford Silver Plate Company, Rockford, Ill., which have been for some time in search of a first-class plater, have at last secured a man from Philadelphia, who will assume charge in September. Orders from the trade are coming in so much in excess of previous years that the capacity of this department is taxed to its full extent. The company are now putting in an additional motor, so as to run silver solutions continually, without any break at the noon hour. This will increase the output one-third.

—The "old reliable house" of Jos. Noterman & Co., 203 and 205 Race street, Cincinnati, are having a brisk trade in their celebrated "Olympus" diamond goods, a line of white stones mounted in all forms, the most tasteful and artistic. The stones are especially cut and imported by them, and the polish is as high as that of the real gem. Notwithstanding the excellence of these goods, they are put upon the market at a price charged for a much inferior article. In buying white stone goods, remember the "Olympus" trade-mark."

—A remarkable line of novelties in metal goods is now being exhibited by the Riley & Osborn Mfg. Co. in the parlors of the Prescott House, 529 Broadway, New York. Their line of oxidized silver goods includes toilet, manicure and work-box sets, shaving mugs and numerous other novelties. In smokers' sets, toilet articles and general bric-à-brac, the assortment is extensive and the designs original and unique. Worthy of inspection is a line of art metal goods, consisting of onyx tables, piano lamps and various other articles of ornament.

—President Carnot, of the French Republic, who strolls through the Exposition buildings quite frequently to examine the exhibits, has greatly admired the fine gold-headed canes in the display of J. F. Fradley & Co., the celebrated manufacturers of New York. This came to Mr. Fradley's ears, and a representative of our Government suggested that it would be a good idea to present to the President one of the quartz-mounted canes which he especially admired. Accordingly, at the close of the great fair, it has been arranged to have a formal presentation. The following inscription will be engraved on the cane: "Presented to M. Carnot, President of the French Republic, by a citizen of the United States of America, as a mark of esteem and a recognition to the French nation of the cordial reception his countrymen have received."

—Fowler's English Crape Stone has become a staple with the jewelry trade. No more appropriate article for mourning wear has ever been devised, its corrugated crape-like surface harmonizing perfectly with the fashionable mourning costumes of the day. The jeweler can protect himself against deception by remembering that Fowler's English Crape Stone jewelry is carded on crape-bordered cards, with the words "Fowler's English Crape Stone" embossed plainly on each card. None are genuine without this stamp and carding. Buyers of mourning jewelry should remember this fact if they want reliable goods of style and reputation.

—The veteran of the lathe makers is John Stark, of Waltham, whose father, John Stark, way back in the sixties, began the arduous task of introducing a lathe of American make, with many improvements of his own invention. By dint of perseverance and careful study of the watchmaker's requirements, Mr. Stark succeeded in perfecting a tool which has met with the unqualified approval of the trade. The father's mantle has fallen upon the son, the present John Stark, who was educated in his father's shop, and understands the business thoroughly. As the result of his later experience and experimenting, he has added a number of very desirable improvements to the celebrated Stark lathe, until at the present it is the peer of any in the market. The "letter E," which is shown elsewhere in this number, combines some features that cannot be found elsewhere, notably a lateral feed screw and micrometer stop screws. Mr. Stark also manufactures a mainspring winder which he claims to be the best in the market.

—Geo. L. Vose & Co., makers of the celebrated "original separable button," have a new button with which they will astonish the trade shortly.

—Walter E. White, of W. E. White & Co., Providence, who has been seriously ill for some weeks past, is rapidly convalescing, and will soon be able to attend to business.

—The stock of chatelaines at the office of Hipp. Didisheim, 83 Nassau street, New York, is complete and extensive. B. Didisheim arrives on September 1 by the *Champagne*.

R. & L. Friedlander, 65 Nassau street, New York, have added to their extensive stock of watches, jewelry, tools, materials, optical goods, etc., a full line of cuckoo clocks and cuckoo clock materials.

—Kirby, Mowry & Co., manufacturers of gold jewelry, Providence, R. I., have opened a New York office on the sixth floor of the Corbin building, corner John and Broadway, in the office of Charles Glatz. The office is in charge of D. K. Perrine.

—The "Marquis" pattern in flat ware is illustrated in this issue by F. M. Whiting & Co. It is shown in plain and fancy pieces, and is very attractive in design. Their new assortment of berry bowls, water pitchers, etc., merits the early inspection of purchasers.

—The Sterling Company, Providence, R. I., will show in its autumn line nearly one hundred different articles of ornament and use exemplified in a thousand designs, in which novelty and beauty vie for supremacy. The company's representatives now on the road are taking many large orders for September and October delivery.

—* H. & H. is a trade-mark that has long been recognized as a guarantee of the highest quality in rolled plate chains. The manufacturers, finding that their name was being infringed upon, have adopted a series of marks to indicate the quality of their chains. These tags or marks are illustrated on another page, and should be carefully noted by every retail jeweler.

—On Aug. 19, a fire in the upper floors of the building, 298 Broadway, New York, caused slight damage by water to the stock of Jacot & Son, musical boxes and novelties, which was fully covered. The fire was soon extinguished and business was but temporarily delayed. The Messrs. Jacot have prepared for the fall trade the finest and fullest stock they have ever carried, and they can show visitors several novelties.

—Major C. H. Case will represent the jewelry interests of Hartford, Conn., in the semi-centennial anniversary of Connecticut Odd Fellowship at New Haven September 3. He will serve on the staff of the chief marshal, being one of the two Odd Fellows selected from Hartford for the position of aide. The Major is one of the most popular men of his town, and the growth of his business is keeping pace with his popularity.

—Among the concerns that realize the importance of the artistic element in their productions is the Derby Silver Co., of Birmingham, Conn. They are sparing no pains to have their line distinctive and unique in design and finish. Their line of novelties, such as toilet sets, necessaires and ornamental pieces, is one of the most varied and tasteful to be found. The oxidized finish on their goods has a peculiar rich burnished appearance that is seen on no other productions. Dealers who are looking for oddities in this line can always count on finding plenty of them in the stock of the Derby Silver Co.

—Foster & Bailey have a new glove buttoner in rolled plate, which is certain to prove a good seller once it is seen by the trade. The wire is very flexible, and it terminates in balls that can be locked together by twisting when the buttoner is not in use, thus permitting it to be fastened securely almost anywhere, in the button of the glove, on the watch chain, or in the buttonhole of the bosom. They are now ready to supply all orders for this little necessary, and on account of its exceeding cheapness a large sale is certain to follow. Their new calendar locket and game counter, patented, is one of the most taking novelties of the season.

—Among the numerous art glass goods that dealers should examine are some beautiful hock glasses, in exquisite combinations of colors, that C. Dorflinger & Sons, 36 Murray street, have just produced. Some are plain, others fine cut, while those engraved in rock crystal style are of especial beauty. The handsome show rooms of this firm undoubtedly contain the largest display of fine cut glass exclusively of any such establishment in the country. All the wall and show cases are filled with goods, many of which are new, and all appropriate to the autumn season. Noticeable is a full assortment of water bottles or carriers, which are especially popular at present for use on the dining table.

—Among manufacturing jewelers who never seem to experience a "dull" season, and whose force is kept busy during the entire twelvemonth, are Carter, Sloan & Co., of 15 Maiden Lane, New York: This firm, as most readers know, manufactures extensive lines of staple goods, as well as many novelties, with complete stocks of which they are now ready for the autumn trade. Just now their great aim appears to be the producing of gold bead necklaces and miniature brooches fast enough to satisfy the demand existing for these fashionable articles. The miniatures, which are imported, are as artistic as they are beautiful, being set in finely wrought gold frames, or encircled by pearls and diamonds.

—Exquisitely pretty pottery recently placed upon the market, and especially adapted to the jewelry trade, is known as George Jones Crescent China, and is made in sugars, creams and fancy little teapots. Numerous new designs are contained in the stock of Bawo & Dotter, 30 Barclay street, New York, which comprises also several new shapes in Royal Worcester, new designs in Doulton ware with tapestry ornamentation, Carlsbad ivory ware which closely resembles Royal Worcester, Crystal spring glass in flower vases in various new patterns, charming after dinner sets in Carlsbad china with fluted surfaces, many unique ornaments in Bohemian ware, and an almost infinite number of novelties in other classes of Ceramics. Dealers should inspect this stock.

—We notice that the marine chronometers exhibited by H. H. Heinrich, of this city, at the Paris Exposition are receiving much praise from the technical watchmakers' journals of Europe. *The Goldschmid*, of Vienna, Austria, considers that these chronometers, with the three separate improvements, place their manufacturers at the head of all marine chronometer makers. The improvements are as follows: 1st, a simplified application of weight for compensation in ordinary temperature from 40 to 95 degrees Fahrenheit; 2d, an auxiliary balance for compensation in extremes of temperature—self-adjusting compensation; 3d, a new system for regulating the isochronism, and for regulation in positions. Ample information in reference to these improvements can be obtained by addressing Mr. Heinrich, 14 John street, New York.

—The Julius King Optical Co., Cleveland and New York, is one of the rising concerns of the country in this line. They spare no pains in their business to supply their trade with perfectly reliable goods, introducing many improvements of their own invention. This, together with the fitness of their salesmen, accounts for the remarkable success they have had. Every traveler they send out is thoroughly posted in all the ins and outs of the optical business. Their new set of "Elite Test Lenses" is as complete and accurate a thing of the kind as any in the market. The process of manufacture is largely original with them, and the most rigid scrutiny is given to each individual lens. Thus it happens that only the highest grade of work is permitted to pass out under the name of the Julius King Optical Co., a name that is now synonymous with reliability and accuracy.

—The old-established pen house of Aikin, Lambert & Co. (incorporated) are now dispatching their travelers over the entire United States and Canada with the finest line of gold pens, pencils, charms and novelties that the house has ever shown. C. G. Megrue, Jr., and S. W. Jenkins will take their old routes through the Northwest. A. S. Canney, recently with the John Holland Pen Co., will represent them in Canada, in the Rocky Mountain region and on the Pacific Coast. Pennsylvania, Ohio and Michigan will be taken care of by M. F. Thornton, late with the Leroy W. Fairchild Co., while the South will be covered by W. N. Shute. J. C. Wakefield, W. S. Eaton and H. A. Lambert will still visit their numerous friends in the Eastern States. In addition to these, five others will carry samples of Aikin, Lambert & Co.'s goods in different sections.

—The American Horological Institute, opening in Philadelphia on October 1st, 1889, is rapidly getting into working order. No pains are being spared to make this the model school of the continent. The course of study embraces watchmaking, engraving, jewelers' work, optics, etc., etc. In the theoretical department, classes, both day and evening, will be held in free hand and mechanical drawing, arithmetic, geometry, trigonometry, mechanical principles, including escapements; optics and chemistry illustrated; also all that is essential to thoroughly prepare a pupil for running a first-class watch and jewelry establishment. The officers court inspection of their methods, tools and facilities, confident that these will be found in advance of the best now in use. They refer to the Elgin National Watch Co., Waltham Watch Co., E. Howard Watch & Clock Co., Seth Thomas Clock Co., American Watch Tool Co., and Louis A. Scherr & Co., Philadelphia, Pa.

—Alfred Krower, of Albert Lorsch & Co., 37 Maiden lane, New York, left for Europe on August 31st, by the *Umbria*. He will be gone several months, and will combine business with pleasure.

—Sanford & Cook, the diamond dealers of 14 John street, inform us that by their prompt action they secured themselves completely against loss by the rascality of Alfred Post, the Chicago "Napoleon of Finance."

—The new factory of the Courvoisier-Wilcox Manufacturing Co., now nearing completion, in Newark, N. J., promises to be one of the handsomest manufacturing establishments in that city. It is expected that the building will be ready for occupancy in October.

—Visiting retail jewelers from leading points are profound in their praises of the beautiful "Belleek" china exhibited by the Otto & Brewer Co. at their art rooms, 177 Broadway. No jewelers catering to a refined trade should leave the city without seeing this company's exhibit.

—James E. Spencer, of the Spencer Optical Co., returned last week from a two weeks' vacation at Richfield Springs, N. Y., feeling much improved after experiencing the pleasures of that fashionable resort. On his return he found business in a flourishing condition, and prospects for the fall trade very favorable.

—If jewelers would, with a small compass, test every watch brought to them for repairs for traces of magnetism and be able to demagnetize such watches as they find magnetized, they would add to their profits and reputation. The Berlin Demagnetizer advertised on page 8 is said to do the work thoroughly and surely.

—Dealers in the finer class of goods while visiting New York this season should pay a visit to the show rooms of S. Klaber & Co. at 47 West Forty-second street, where they would find it to their advantage to examine the beautiful stock of Mexican onyx pedestals, tables, clock cases, etc., there to be seen. The show rooms are centrally located, being near the Sixth avenue elevated railroad station and the Grand Central depot.

—Blancard & Co., manufacturers of settings, galleries, etc., 36 John street, New York, report business as being very good. They are at the present time in receipt of more large orders than any corresponding time of previous years. This favorable state of things is owing to the fact that they are always getting up something new in their lines, that the goods they furnish the trade are, as to quality, what they are represented to be. The best of workmen are always employed and they turn out perhaps the finest-finished goods of their class now on the market.

—The affairs of the Manhattan Watch Co. are in a lively state, as may be seen by a visit to the office. All their travelers are out on their respective territories, and are sending in numerous bulky orders. Though the factory is taxed to its utmost capacity, it is 3,000 watches behind on orders on hand. The filled cases recently placed upon the market by the company have proved successful, orders for them coming in a steady stream.

—Retailers who do not desire to be counted among the dead men will read and reflect upon the advertisement of the Rogers & Hamilton Co., Waterbury, Conn., which is presented in so novel a form on another page. The Crown-Hamilton and Rogers-Hamilton brands of flat ware have already achieved so wide a popularity for their sterling qualities and originality of design, that it may be said with perfect truth that they are as well known to-day as many makes that have been on the market for a generation. The Rogers & Hamilton Co. are about to publish a new illustrated pocket price-list of their manufactures, which dealers are requested to send for at once.

—S. F. Myers, while on a western trip last month, disposed of the remaining fund contributed by the members of the New York Jewelers' Board of Trade for the relief of the survivors of the recent terrible calamity at Johnstown, Pa. The contributions originally amounted to over \$1,700; of this, \$1,000 were merged in Mayor Grant's fund, and at a meeting of the Board it was decided that the remaining sum, \$700, should be placed at the disposal of Mr. Myers and August Oppenheimer, who were appointed a committee, to be used as they deemed best. In his report to Secretary Condit, Mr. Myers stated that with one exception, each surviving jeweler received a draft for \$100. The exception was William A. Kraft, to whom \$150 were given. Mr. Kraft was particularly unfortunate; his wife and children, who had been carried away with him, were lost and he himself had been picked up in an unconscious condition. J. A. Larkin and J. W. Stevenson are the only jewelers who have thus far been able to reopen their stores. Those benefited, besides the above-mentioned, are Mrs. Young and Adolph Luckhardt.

—That the purpose of horological schools in this country (to afford an opportunity to those desirous of learning the trade of watchmaking and repairing, to master the art in a fractional portion of the time usually devoted to it in the jewelry store) is being realized, was fully evidenced last month by several specimens of the work of the students of J. L. Hutchinson's school at La Porte, Ind., which were submitted to our criticism. These specimens consisted of an enlarged lever escapement model, a balance staff model, a burnisher model, a drill model, four variously designed vibrating stands, and a small chronometer watch. All represented the work of students who had not received over three months' instruction. They had been submitted to the opinion of the Hampden Watch Co., who spoke high in their praise. John Bliss & Co. also examined the balance staff and reported very favorably on its work and the method pursued by the institution.

—Odenheimer & Zimmern, 69 Nassau street, New York, have just issued to the trade an ingeniously-conceived and neat, cloth-bound little book, that combines the characteristics of a memorandum book, descriptive illustrated catalogue and price list. Each page contains an illustration and description of a new design in their well-known interchangeable initial rings, lockets and sleeve buttons. Several pages are devoted to illustrations of their alphabet of initials. The book is small enough for the vest pocket, and is a neat means of preserving memoranda. An important item in connection with this little book is a telegraphic code contained therein, which has been adopted by the firm for the convenience of customers, and in order to avoid mistakes in transmitting orders by telegraph. A new initial locket which the firm have placed upon the market is very handsome; the ground is in satin-finished gold, the initial being in relief of polished gold. The demand for O. & Z.'s initial goods is ever on the increase. The volume of business in these goods during the first unusually dull six months of 1889 far exceeded that of the same months of 1888.

—Addison Conkling, widely and favorably known in the trade, has accepted the general selling agencies of both the Aurora Watch Co., of Aurora, Ill., and the Essex Watch Case Co., Newark, N. J., and for the better accommodation of customers and friends in the trade, whom Mr. Conkling is ever pleased to welcome, he has opened a spacious office at 6 Maiden lane, New York. The office is perhaps more centrally located in respect to the trade than that of any other watch or case company, being in a building that has always been known as being distinctly devoted to jewelry interests; it is neatly fitted up, and has a bright and inviting appearance. A full line of Aurora movement in 18 and 6 sizes, and a complete assortment of styles and patterns of Essex cases will be kept constantly on hand, and new grades and styles constantly added. Though the office has been in existence scarcely more than a month, its success is already felt; both factories are running to their utmost capacity in order to fill orders on hand. Samuel B. Mann, than whom no one in the trade enjoys a more flattering reputation for ability as a salesman, general integrity and geniality, will cover the southern territory for Mr. Conkling. Mr. Mann brings to bear upon his duties an experience of nearly 15 years gained with J. T. Scott & Co., and several years as Eastern agent of the Rockford Watch Co. Under these favorable circumstances we feel the assurance expressed by the Companies, that the outlook for their interests is very satisfactory.

—Some of the new designs in silver-headed canes, umbrella handles, crops and riding whips, now being shown the trade by the Alvin Manufacturing Co., of Newark, N. J., are marvels of combined beauty and oddity. This enterprising firm is continually producing new and beautiful effects in their process of depositing pure silver. Among the many new patterns shown this season in cane handles, is one consisting of a Weichsel root covered in portions by a deposit of pure silver etched in a rustic design, with a massive serpent in chased silver trailing its folds through natural openings in the root. Another new and beautiful effect is produced by covering pearl handles with an etched deposit of silver in portions, as well as the ever popular styles in antique ivory. Owing to the difficulty of duplicating patterns, a great measure of the beauty of which consists in the natural form of the stick selected for applying the silver, they will send reputable firms canes, umbrella heads, riding and driving whips, crops, etc., on memoranda for selection. They are also showing a large line of designs in chatelaines, buckles, pungents and other novelties in silver, as well as a beautiful line of glass decorated goods of which it is scarcely necessary to refer owing to the reception that they have received from the trade at large. They desire the trade visiting the city to be informed that a complete sample line of their goods, as well as several odd pieces that cannot be duplicated, can be seen at their New York office, 10 East Fourteenth street.

—A. J. G. Hodenpyl arrived from Europe on August 22d by the steamer *Veendam*.

—Geo. W. Fairchild, of the Leroy W. Fairchild Co., returned from his wedding trip to Europe on Aug. 25, by the *Normandie*.

—S. Cottle Co., 860 Broadway, New York, have placed on the market a new collar button which is uniquely illustrated in another portion of this issue.

—The third annual picnic of the Mutual Benefit Association of the Solidarity Watch Case Co., of Brooklyn, N. Y., was held at Ridgewood Grove, Brooklyn, on August 24. It was well attended, was a jovial affair, and netted considerable money toward the fund of the association.

—The *New York Jeweler* of September, published by S. F. Myers & Co., 48 Maiden Lane, New York, is a very interesting issue. Special bargains are offered in a line of nickel and fancy clocks, which is being closed out to make room for new lines of fall goods; also in discontinued watches and silver-plated ware. Several new designs in "Globe" cases are shown, as well as in the "Regent" and "Crescent" 14 k. gold filled cases made by the Waltham Watch Co., and "Monarch," "Conqueror" and "Montauk" gold-filled cases made by Fahys Watch Case Co. The firm's corps of salesmen is now all out in their respective territories, the last four, James S. Knowles, M. S. Weand, A. D. Nelson and C. A. Bucklin having started last week.

—The visitor to the establishment of L. Straus & Sons, 42—48 Warren street, New York, the well known importers of fancy goods, will require a very large note book if he is to put down everything that interests him and that ought to be remembered by him. Of the exquisite Vienna hand-painted vases so much admired now, a very large line is shown. Royal Dresden ware, which is more popular among jewelers this season than ever before, is represented by the finest and most varied line the house has ever imported. The Royal Worcester factory has been producing many new styles of late and samples of all the latest and most desirable of them are found in the array. Of course the rich Doulton ware is not forgotten, nor the Crown Derby so costly and recherche, and now more fashionable than ever. The leading specialty of this house is perhaps the Rudolstadt elite ware which rivals the Royal Worcester. Some of the most attractive styles are the Voltaire, the St. Denis, and the Calderon. L. Straus & Sons are the sole agents for these goods for the United States. The antique ivory and matt antique varieties are also very choice and sell readily. It would be unpardonable to omit to mention a line of new English vases and pieces called the Eglantine, an English vellum, wonderfully delicate and dainty and as cheap as they are pretty. In cutglass the house announces a boom. They are unable to fill their orders notwithstanding their increased facilities, on the Venetian cut (a patent of their own), the Peerless, the Escutcheon, the Radiant, the Renaissance, the Electra, and the Prismatic, another pattern of their own designing.

—In the busy little city of Waltham, Mass., made famous by the development of the American watch industry, there is a modest little school for instruction in horology that is well worthy of being brought to the attention of the student. D. D. Palmer, for many years in charge of the adjusting department of the Waltham factory and an expert in all branches of horology, has for a number of years made a practice of taking apprentices under his own personal tuition. Some of the best horologists in the country owe their success largely to the thorough grounding received in the institute of Mr. Palmer. Many of his pupils occupy positions of responsibility in the watch factories of the land. So encouraging have been the results both to teacher and students that Mr. Palmer has decided to increase his accommodations for students and offer the singular advantages which his school affords more generally to the trade. Among these advantages are the following: In the first place all branches are under the personal supervision of Mr. Palmer, the benefit of direct contact with a teacher and investigator of over thirty years experience. The school being located in Mr. Palmer's own house, the pupil can have the use of tools and power at any time he chooses, day or evening. Every operation in the manufacture of the complete watch comes under the observation of the pupil as a patented movement called the "Palmer Watch," is made by the students in the shop. Thus thorough efficiency is secured. Again, from Mr. Palmer's long experience in watch factories, he is able to take the student through all the operations and explain them fully. Many of these advantages can be obtained no where else in this country. Those who are intending to take a course in horology should apply to Mr. Palmer by mail, or make a visit to Waltham to inspect the school, where they will be cordially welcomed by the genial proprietor.

—The National Wholesale Jewelers' Protective Association is receiving new members from all parts of the country. The Chicago jobbers are organizing, and will elect a representative to the Executive Committee during September. The jobbers of Philadelphia, Cincinnati, San Francisco, Pittsburg and St. Louis are also about to organize for the same purpose.

—Dealers, in selecting goods for their holiday trade, should not overlook the attractive stock of new goods displayed at A. Klingenberg, 37 Park Row, New York, and which contains, besides new shapes and patterns in Royal Worcester, Doulton, Pointons, Sevres, Royal Dresden, Hungarian, etc., several handsome novelties in Carlsbad ivory ware, very rich new jardinières of Bonn, Faience, new vases, jugs and fancy pieces in Carlsbad clematis ware, which are exquisitely beautiful, and a full assortment of white and gold bisque figures.

—Thomas G. Brown & Sons, as may be seen by referring to their advertisement on another page, have gone largely into the manufacture of sterling silver novelties. At their office, 860 Broadway, can be examined an endless variety of new designs in such articles as flasks, match boxes, cigarette cases, etc., new designs in articles suitable for the desk or library table, articles for the toilet, novelties in photograph frames and standing mirrors, silver jewelry, etc. They are making a feature of canes and umbrellas and an extensive assortment with silver and gold mountings has been prepared. The umbrellas are made up in four qualities of silk. The stock is well worthy an inspection.

Among the Watch and Clock Companies.

—The E. Howard watch factory shut down last month for vacation.

—The Seth Thomas Clock Co. are at work upon a new clock for the capitol building at Harrisburg, Pa.

—The Trenton Watch Co. started up on the 13th of August with a full force and pitched for producing 250 watches per day.

—The electric light plant now being added to the Elgin Co.'s works is expected to be completed within a month.

—The work in the new Otay (Otay, Cal.) watch factory is making satisfactory progress. Lathes that are capable of doing work to the exactness of a thousandth of an inch are now in running order.

—The Waterbury Watch Company are at present employing 475 hands—300 females and 175 males. The pay of the females, mostly girls, averages \$1.75 per day, and that of the males, including a large number of boys, \$2.50 per day. The output is approximately 1,000 daily.

—The Non-Magnetic Watch Co. have fitted with modern improved American machinery and now occupy the fine stone building erected for Tiffany & Co. as a watch factory in Geneva, Switzerland, and are there manufacturing the Paillard balances for all their numerous plants.

—Deliveries of the "new nickel" Cheshire watch are now being made. Orders for these watches have been far ahead, and it has been difficult to satisfy the demand. The improvements in this watch consist of a second hand and hanger bezel with imitation gold joints.

—Experts employed in the Otay Watch Factory have constructed a complete model watch. It furnishes a model for each and every part, on which it is intended that separate machinery will be set to work and thus simultaneously turn out the entire running gear in a short period of time.

—The Non-Magnetic Watch Co. have just received at their office, 177 Broadway, New York, a large line of complicated watches, chronographs, split seconds, repeaters, etc., and ladies' small size watches beautifully jeweled and enameled. It would pay jewelers seeking something extra fine to inspect this stock.

—The Aurora Watch Co. find the demand for their No. 10 movement extremely difficult to supply. Their business in all grades is gradually increasing, and with opening of the New York office and the installation of so capable a man as spoken of on another page, a prosperous fall trade is anticipated by the company.

—The popularity of the new Trenton watch is evinced by the rapidly increasing demand. Most of the visiting jobbers ordered and laid in large stocks of these watches, and as the company are doing some effective advertising and have several missionaries in the field, jobbers who have informed their customers that they have the new Trenton, are doing a good business.

—Interested parties are endeavoring to induce capitalists in New York, Rochester, and Baraboo, Wis., to start watch factories.

—The American Watch Co. have just issued their new ladies' 6 size gold pendent set hunting case watch. The new feature in these watches lies in their pendent setting; they are cased in various qualities of gold and are very handsome.

—The Elgin Watch Co. have in contemplation the erection of a solid brick row of buildings, numbering twenty or more, and comprising a small village, to be leased to their factory employees at a reasonable rent. The new houses will be fitted with all conveniences, water, lights, etc., and will be of great benefit to the operatives.

—The Western Union Telegraph Co. are sending agents about the country soliciting orders for their self-winding electric clocks, recently purchased from the erstwhile Self-Winding Clock Co. The company install the clocks on a rental basis of \$1 monthly, and guarantee that they will not tolerate a variance of one-sixtieth part of a second from standard time.

—The Soho Clock Factory (W. F. Evans & Sons), Handsworth, Birmingham, England, are doing a large trade with the States with their grandfather, chime and other clocks, and South America is demanding a large number of their jeweled lever saloon clocks. The jubilee year in England gave this firm large orders for church, chime and quarter clocks for churches, etc.

—Some of the local papers, last month, erroneously stated that the plant of the New Haven Clock Co. was to be temporarily shut down to allow the operatives a vacation. The vacation applied merely to a few of the hands in the marine department which at present is not very busy. The demands, however, in the remaining departments are too heavy to allow of any cessation.

—A statement has been circulating among the local papers of the watch manufacturing towns, that the Keystone Standard Watch Co. have in contemplation, the removal of their plant to Springfield, Mass. In refutation of this rumor, President Geo. M. Franklin says that "there is no foundation whatever for the rumor that the Keystone Standard Watch Co. will be removed to Springfield, Mass., or to any other place. Lancaster is the best location we know of for manufacturing and we intend to remain there."

—The directors of the Dubuque Board of Trade met in special session in the early part of the month to consider a proposition of the Non-Electric Watch Company, of Chicago. The company propose that Dubuque buy \$30,000 worth of land and that half of it be donated to the company as a site. The company guarantee that they will employ 1,200 men and turn out 600 watches a day. The proposition was referred to the real estate committee with instructions to look up the ground.

—The Crescent Watch Case Co., issued last month a new screw bezel double stock case, silver and nickel, 18 size pendant setting, bassine, which they christened the "Century." These cases are made on the same principle as the double stock Bond Street cases which are so well known and popular with the trade. The pendants and bows are of solid coin silver; the body of the case and glass bezel is made of double stock, composed of coin silver and nickel, one-third being silver; this combination makes a watch case that has the wearing qualities of a solid silver case, and being dust-proof, affords perfect protection to the movement.

—Business at the United States watch factory, Waltham, Mass., appears from all accounts to be booming; additional help are taken in daily, and the orders for their remarkably accurate and highly finished watches are away ahead of the capacity of the factory to fill. The output reached seventy-five watches per day during August, which is the largest yet attained, though it is expected to reach 100 by October 1. In the spring the factory buildings are to be enlarged to more than double the present tool and bench capacity, and additional expert watch tool machinists are sought after to produce the needful machinery. The product of the company has taken a sudden spurt under the management of Supt. Granville Nutting.

—The Waterbury Clock Co., whose salesrooms are at 10 Cortlandt street, New York, have just issued their August, 1889, catalogue, which will be furnished the trade on application. The book is profusely illustrated and contains numerous new designs, all of which can be seen at the salesrooms. The first 24 pages are devoted to illustrations and descriptions of a totally new line of French marble cases fitted with Waterbury movements. Besides, there are depicted several new designs in enameled iron, polished walnut, polished wood, polished veneered and metal, plush and wood cased lever clocks. The line of walnuts is very large and contain numerous novelties. Their line of regulators, bronzes, figures, etc., are fully illustrated. A complete price accompanies the catalogue separately.

—The several improvements being effected at the works of the Elgin Watch Co. cause such activity, that President Avery finds it necessary to run over from Chicago to Elgin twice or three times a week.

—The Boston Clock Co., Boston, Mass., are making a specialty of a marine clock designed for use on yachts. These clocks have chronometer balances and jeweled escapements, and are very attractive in outward appearance.

—The new brazing furnaces recently installed in the Elgin watch factory have been tested and found to work fully up to all expectation. It is expected by this invention, for which George E. Hunter, an employe in the factory, is responsible, a revolution in the process of brazing will be effected.

—The Columbus Watch Co. are running full force, and are daily increasing their product with the expectation of reaching in September 200 watches a day. The company are desirous of doubling or trebling their capacity, and are contemplating an increase in their capital stock, in order to satisfy the demand for their popular watches. They are unwilling to leave the State of Ohio, and there is some likelihood of their moving to another part of the city, where residents may give land and take stock.

—The daily output of fifty watches from the United States Watch Factory, at Waltham, Mass., will be increased as soon as the necessary tools, now being made, are ready to perform the work. This is a healthy sign. The company has had a handsome offer to locate in a western city within the past three weeks, and it is said that the inducement held out would turn the heads of managers of many factories who employ even more hands than does the United States shop, but the offer is but one of the many that this company has had during the past year, all of which have been refused.

—Two new lathes and other new machinery have been received at the watch factory at Otay, Cal. These lathes, for fine work, have

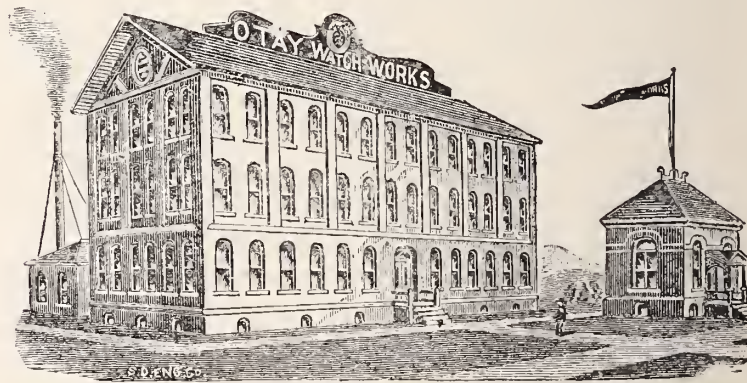

been put in place and the process of watch making begun. Other machinery is expected soon, and machinists of first-class ability are busy arranging for the introduction of the more complicated work.

JOHN JAMES HYDE.

On the 20th of last month, at St. Servan, France, died John James Hyde, a member of John E. Hyde's Sons, one of the oldest and best known firms of watch importers in this country, and introducers of many of the improvements in watches that have been made during the past 40 years. The firm were the introducers and always been the wholesale agents of the famous Jurgensen watch, the best watch made.

Mr. Hyde was born in 1816 and was a son of John E. Hyde who founded the present business in 1818, and was at one time well-known in New York. He received his education partly in New York and partly in Paris, and as a young man, was an amateur artist of considerable repute, some of his work, exhibited at the Paris Salon having achieved a share of success.

He was appointed Paris representative of New York house, in 1837, and remained such until 1842, when he returned to America and took charge of the home business. About eight years ago he was stricken with paralysis, and was compelled to retire from active commercial pursuits. In 1887 he was taken by his family to France, where he remained until his death. He leaves a widow two daughters and two sons. His eldest son, J. Hinton Hyde, is a member of the law firm of Betts, Hyde & Betts, while the younger, William H. Hyde, is pursuing art studies in France.

TABLE OF CONTENTS.

Around Boston.....	53	Glimpses of the Paris Exposition.....	32	Jewelers' Security Alliance.....	54	Providence Notes.....	49
Attleboro, The.....	101	M Falze on the American Exhibit.....	32	Jewelers' and Tradesmen's Company, The.....	54	Quaker City, The.....	46
Chain, The.....	78	Standard Time Service and Seth Thomas Clocks.....	32	Mechanical Ocular Defects.....	65	Recent Patents.....	85
Chicago Briefs.....	42	Exhibits of Geo. Agassiz and E. Fracillon.....	36	Mutual Relations of Refraction, Accommodation and Convergence.....	65	Repeating Arrangement for Watches and Clocks.....	74
Communications.....	93	The Gorham Co.'s Exhibit.....	37	Northwest, The.....	50	"Safest" Watch, The.....	81
Complete History of Watch and Clock Making in America—Watch Case Making.....	86	Exhibit of American Precious Stones.....	41	Obituary—Nathaniel Grant—Wm. F. Ladd, Fred'k W. Gesswein—Elijah Peacock, Sigmund Hymen—Alzamora Buck.....	98	Trade Gossip.....	105
Does it Pay to be Ilonest?.....	31	J. F. Fradley & Co.'s Exhibit.....	42	Our Round Table.....	99	Among the Watch and Clock Companies, 113	
Fashions in Jewelry.....	58	History of the Bracelet, The.....	69	Paris Gossip.....	57	To Revamp Nickel Movements.....	46
" Art Glass and Ceramics.....	61	Improved Arbor for Clocks.....	66	Problems in the Detached Lever Escapement.....	81	Two Recent Optical Inventions.....	66
Foreign Gossip.....	73	Improvement in Complicated Watches.....	82	Proceedings of the Watchmakers' and Jewelers' Union.....	89	Universal Watch.....	77
Foreign Matters.....	97	In the South.....	102			Workshop Notes.....	70
Gossip of the Month.....	27	Jewelers' League, The.....	82				

INDEX TO ADVERTISERS.

Aby, Chas. Leo.....	52	Falkenau, Oppenheimer & Co., Outside bk cov.		Mathey Bros., Mathez & Co.....	12	Shiebler, Geo. W.....	84
Alkin, Lambert & Co.....	63	Fisher & Sons.....	76	McCall & Newman.....	64	Smith & Knapp.....	64
American Horological Institute.....	92	Floyd, Pratt & Rounds.....	96	McCarty & Co.....	6	Smith, Alfred H., & Co.....	29
American Waltham Watch Co.....	44	Foster & Bailey.....	39	Merritt, S. F.....	14	Smith B. & W. B., outside back cover	
American Watch Tool Co.....	76	Fox, M. & Co.....	48	Middletown Plate Co.....	3	Smith, H. M. & Co.....	56
Ansonia Clock Co.....	2	Fradley, J. F. & Co.....	30	Miller Bros. & Co.....	56	Special Notices.....	117
Arnstein Bros & Co.....	24	French, J. H.....	50	Montgomery & Co.....	123	Spencer Optical Mfg Co.....	9
Atkinson Bros.....	68	Friedlander, R. & L.....	24	Moore & Horton.....	64	Stark, John.....	14
Ball, Wm. H. & Co.....	22	Froelich, H. & Co.....	24	Morse, Mitchell & Williams.....	25	Sterling (The) Company.....	4
Barrows, H. F. & Co., Outside Back Cover		Fuchs, Ferd. & Bro.....	100	Muller's Sons, Nicholas.....	2	Stern Bros. & Co.....	56
Bartholomew & Peckham.....	123	Geneva Optical Co.....	23	Myers, S. F. & Co.....	96	Stern & Stern.....	13
Bawo & Dotter.....	34	Glaenzler, Leon J.....	111	N. Y. Watch Case Spring Co.....	117	Stockwell, E. R.....	64
Beguelin, Teil A.....	116	Gorham Mfg. Co.....	26	Newman, Louis, Jr.....	123	Straus, L. & Sons.....	60
Bedichlmer, I.....	56	Haldimann, E. A.....	24	Nissen, Ludwig, & Co.....	63	Sussfeld, Lorsch & Co.....	48
Berger, Albert & Co.....	16	Hartford Silver Plate Co.....	12	Non-Magnetic Watch Co.....	40	Taintor & M. Alpine.....	96
Berlin Demagnetizer Co.....	8	Haskell, H. C.....	92	Noterman, Jos. & Co.....	56	Tannenbaum, L. & Co.....	84
Birch, John S., & Co.....	116	Hausburg, O. E.....	123	Nye, Wm. F.....	8	Taylor & Bro.....	84, 87
Blancard & Co.....	75	Hearn & Braitsch.....	15	Odenheimer & Zimmern.....	124	Ternandt, F.....	123
Bookhout Bros.....	123	Hedges, A. J., & Co.....	63	Oppenheimer Bros. & Velth.....	67	Thurnauer, G. M.....	15
Bowden, J. B., & Co.....	92	Hedges, Wm. S. & Co.....	71	Oppenheimer, Henry E. & Co.....	88	Todd, Ed. & Co., Outside back cover.	
Braxmar, C. G.....	123	Helmrich, H. H.....	56	Oskamp, Nolting & Co.....	20	Towle Mfg Co.....	96 & 99
Bradley & Hubbard Mfg Co.....	88	Howard, S. P.....	Outside back cover	Ostby & Barton.....	79	Trenton Watch Co.....	112
Bryant, M. B. & Co.....	52	Hyde's Sons John E.....	76	Ott & Brewer Co.....	91	Troemner, Henry.....	123
Buhler & Nanz.....	68	Imhauser, E.....	123	Owen, G. & S., & Co.....	84	Ulrich, J. L. & Co.....	24
Bynner, T. B.....	123	Jackson, S. C.....	Inside Back Cover.	Pairpoint Mfg Co.....	17	United States Watch Co.....	30
Carter, Sloan & Co.....	47	Jacot & Son.....	67	Peterson & Royce.....	68	Van de Sande, Chas. & Co.....	22
Cattelle & Decker.....	68	Jacques, Charles.....	1	Pforzheimer, Keller & Co.....	76	Valuable Instruction Books, Inside bk Cover	
Chalmers-Spence Co.....	80	Jeandheur, F. Jr.....	48	Pinnell, May & Co.....	6	Wade, Davis & Co.....	72
Champerols & Co.....	75	Jonas, Dorst & Co.....	21	Plainville Stock Co.....	72	Waltham School of Horology.....	96
Chicago Horological Institute.....	52	Kahn, L. & M. & Co.....	22	Platt, Chas. S.....	Outside back cover	Waltham Watch Tool Mfg. Co.....	23
Clark, A. N.....	76	Keller, L. H. & Co.....	116	Pratt, Chas. D. Co.....	83	Wallace, R., Sons Mfg Co.....	60
Colby, C. K.....	100	Kendrick & Davis.....	80	Prindle & Russell.....	75	Want, Edwin.....	24
Conover, D. F. & Co.....	19	Kent & Stanley.....	14 & 79	Racine Jewelry Mfg. Co.....	122	Washburn & Moen Mfg. Co.....	123
Cooke, B. J's, Sons.....	75	Ketcham & McDougall.....	15	Randel, Baremore & Billings.....	104	Watchmaker, Jeweler and Silversmith.....	116
Cottler, C. & Son.....	123	King, Julius, Optical Co.....	20	Reeves, A. Ailing.....	23	Waterbury Clock Co.....	1
Cottle, S. Co.....	51	Klauer, S. & Co.....	15	Richardson, J. W. & Co.....	17	Waterbury Watch Co.....	103
Crescent Watch Case Co.....	44	Klingenberg, A.....	72	Riley, John A.....	55	Well, Maurice.....	24
Cross & Beguelin.....	21	Koch & Dreyfus.....	83	Robert, J. Eugene, & Co.....	35	Welch & Miller.....	80
Crouch & Fitzgerald, Outside back cover		Kohlbusch, Charles.....	123	Rogers & Bro.....	7	Wheeler, Hayden W. & Co.....	60
Cuppla, L. A.....	100	Krementsz & Co.....	115	Rogers & Hamilton Co., The.....	33 & 43	Whiting, F. M. & Co.....	18
Cummings, Josiah & Son.....	6	Lapierre, F. H.....	23	Russell, Chas. A. & Co., Inside back cover		Wilkinson, C. B.....	123
Day & Clark.....	16	Lapp & Flershem.....	95	Russell, Irving L.....	92	Woglom, Gilbert T.....	64
Didlsheim, Hipp.....	48	Laurencot, J. B.....	124	Sartorius, A. & Co.....	123	Wood & Hughes.....	59 & 84
Dorflinger, Chas. & Sons.....	30	Lawson & Van Winkle.....	22	Sauter, L. & Co.....	48	Wood, Chas. F.....	75
Dreyfus, Henry, & Co.....	11	Lelong, L. & Bro., outside back cover		Schleicher, Schumm & Co.....	64	Wood, J. R., & Son.....	123
Dubois Watch Case Co.....	100	Lewis Bro.....	111	Scott, J. T. & Co.....	43	Zimmern, Henry.....	124
Dueber Watch Case Mfg. Co.....	10	Lorsch, Albert, & Co., Outside back cover		Seth Thomas Clock Co., Inside front cover		Zineman, M. & Bro.....	48
Elliot, Geo. & Co., Inside back cover		Mahler, H.....	92	Sexton Bros. & Washburn.....	72		
Essex Watch Case Co.....	115	Marcy, F. I. & Co.....	52	Sheafer, W. H., & Co.....	84		
Evans, W. F. & Sons.....	80						

IMPORTANT.

AN OPEN LETTER.

TO THE JEWELRY TRADE:

We are fully aware that you may already have agreeable trade connections, but we want to impress upon your minds that we have a line of goods which are not to be seen elsewhere, and we are assured by many leading houses that these specialties—suitable for **DECORATING HOMES** and for **WEDDING** and **HOLIDAY PRESENTS**—attract to their stores custom which they can command in no other way.

We are showing new forms and decorations in pottery from England and the Continent, including such makes as **Royal Worcester**, **Doulton**, **Old Hall**, etc., etc. and also a great variety of artistic pieces in bronze and other wares, together with a thousand and one attractive articles of moderate cost suited to meet the demand for **WEDDING AND HOLIDAY** presents that are **ELEGANT** but **INEXPENSIVE**.

An inspection of our **MOUNTED VILLEROY** alone will more than repay you for a visit.

Our stock is entirely new, not carried over from former seasons, and, as we say above, composed of specialties **NOT TO BE SEEN ELSEWHERE IN THIS MARKET**.

Kindly place these facts before your buyers and ask them **NOT TO FORGET US**.

Very truly yours,

McCARTY & COMPANY,

PURVEYORS TO THE JEWELRY TRADE,

525 BROADWAY (near Spring Street), NEW YORK.

JOSIAH CUMMINGS & SON,

MANUFACTURERS OF

STEEL BOUND SAMPLE TRUNKS,

SAMPLE CASES, TRAYS,

ETC.,

FOR THE JEWELRY TRADE.

109 Summer Street,

BOSTON, MASS.

MADE BY PINNELL, MAY & CO.,
Manufacturers of Fine Gold Watch Cases
In 14, 10 and 8-k.

Office, 1½ Maiden Lane, New York.
Factory, 52 Lawrence St., Newark, N. J.
Goods Sold through
Jobbers Only.



The "TIP TOP" is a 14-k. Case weighing about 16 dwts., but constructed in such a way that it will stand as much wear and tear as a much heavier case. Jobbers will find, upon investigation, that the namer knew what he was about.



THE JEWELERS' CIRCULAR

AND

HOROLOGICAL REVIEW.

OFFICIAL REPRESENTATIVE OF THE JEWELERS' LEAGUE, THE NEW YORK JEWELERS' BOARD OF TRADE, AND THE JEWELERS' SECURITY ALLIANCE.

It is also the Recognized Exponent of Trade Interests.

A MONTHLY JOURNAL DEVOTED TO THE INTERESTS OF WATCHMAKERS JEWELERS, SILVERSMITHS, ELECTRO-PLATE MANUFACTURERS, AND THOSE ENGAGED IN THE KINDRED BRANCHES OF ART INDUSTRY.

SUBSCRIPTION.—To all parts of the United States and Canada, **\$2.00 per Annum**, Postage Paid. To all Foreign Countries, **\$3.00 per Annum**, Prepaid.

All communications should be addressed to

THE JEWELERS' CIRCULAR PUBLISHING CO.,
189 BROADWAY, NEW YORK.

Advertising rates made known on application.



A full Index to Advertisements and Table of Contents will be found on Page 5 of this issue.

THE chief benefit of international exhibitions is educational. They enable each nation participating to hold the mirror up to itself and realize its own deficiencies by comparison with the attainments of other peoples. In this respect the Paris Exposition has been an eye-opener to Americans. Many of our citizens who went there prepared to throw up their hats and shout for American supremacy in everything under the sun have come back sadder and wiser men—ashamed of our manifest inferiority to other exhibitors in the matter of industrial art. In silverware and jewelry we have received much deserved commendation, but this is almost the only department in which the United States made a creditable showing. Americans need such a lesson as this. They need to be reminded that there is a higher force in production than our much vaunted machinery, wonderful as that is, and that all these labor-saving appliances are but as means or tools in the hands of the creative intelligence of the artisan. America has still much to learn from the old world, and this great truth of the prime importance of the creative skill of the artisan in all the fields of industrial arts is one of the first we should take to heart. Capital and machinery are but the block of marble out of which the creative intellect chisels the human form. Have we not exalted the secondary factor in production and ignored that which is essential to give true value to the products of our labor?

Our young men have been brought up to look upon the mechanical trades as ungentle and to prefer the dubious fortunes of the speculator and the tape-measurer to the sturdy life of the artisan who fashions shapes of utility and beauty by honest labor of hand and brain. Happily a revulsion of feeling had already begun in favor of healthier and more earnest views of the function of the artisan in the social framework before this last humiliating lesson of the Paris Exposition confirmed the present tendency of our national thought. It is most fortunate that the revelation occurred on the eve of preparation for the great Columbian Centennial of 1892. Now the short time that intervenes before that colossal event may be improved in fostering training schools for the education of intelligent artisans, and endeavoring to draft enough impromptu talent into service to make a more respectable showing than we have just made abroad. Judged by the creditable displays at the Paris Exposition, the jewelry and silverware trades are surely ready for this movement. The more advanced manufacturers realize that the future of their business lies in design—that is, in the art quality of their goods, and are on the lookout for suitable talent. Many of them have taken an active interest in the foundation and maintenance of art schools to supply this want in their business. All these signs give unmistakable evidence of an awakening among our people to the culpable neglect that has characterized us as a nation in respect to the higher branches of industrial education. It is not too much to hope, therefore, that long before the great International Fair of 1892 is a thing of the past this reviving interest will have crystallized in a great national movement for sounder, broader education—education that shall fit our young men and women for something better than tending machines.

* * * * *

Every wide awake jeweler has an optical department now-a-days, and ought to read our optical department, edited by Dr. C. A. Bucklin, M. D.—Vide, "Mechanical Ocular Defects," page 65.

* * * * *

REPORTS of the rise in the price of diamonds, which at first seemed somewhat exaggerated, are daily confirmed by the statements of recent arrivals from the diamond centers, and by cablegrams received from European agents. There is no longer any doubt that a powerful and carefully planned combination of mining interests has been effected at Kimberley, and that prices will be still further advanced before the limit is reached. In his speech at the annual meeting of the shareholders of the De Beers Consolidated Mining Co. last July, Vice-President Barnato said that prices would be raised as much as 40 or 50 per cent., or about 20 or 25 per cent. above present prices of rough, and that they would be held there. He further intimated that no attempt would be made to carry them to so high a point as to choke of the demand, the object of the combination being simply to hold the market firmly and prevent glut and injurious fluctuation. With judicious handling the vast syndicate

will doubtless prove equal to this task, and those who count on a firm and rising diamond market for 1890 are not counting without their host.

* * *

* * *

* * *

Keep your eye on "Our Round Table" and you will find much to Amuse and Instruct.

* * *

* * *

* * *

THE fabulous reports that have reached the East about the richness of the Wisconsin pearl fisheries are doubtless greatly exaggerated. A few good pearls have been obtained, but not enough to pay for the labor of the searchers. Fresh water or unio pearls are found in a number of the States of our Union, and occasionally some rustic makes a big find and sets the whole surrounding neighborhood aglow with excitement. Farmers desert their plows and rush to the rivers to waste time that in most cases might be more profitably employed in raising corn and potatoes. Instances of the finding of splendid pearls like the one which was found by a shoemaker many years ago in a brook near Paterson, New Jersey, and sold for some \$1,200, are very rare. In short, fresh water pearl fishing at present is the proper vocation of the loafers and ne'er-do-wells that constitute the nautical element in country towns.

* * *

* * *

* * *

Last Glimpse of the Paris Exposition before the curtain falls, page 32.

* * *

* * *

* * *

READERS OF THE CIRCULAR, will find much to amuse and instruct in following the discussions of the new Watchmakers' and Jewelers' Union; the proceedings of whose first meeting appear in this issue. In giving publicity to the minutes of this organization it is our desire to stimulate discussion and thus aid in the dissemination of more intelligent methods, and popularize the latest discoveries in all branches of the trade. Correspondence is solicited from all who have suggestions or criticisms to offer. No one need be deterred by modesty or petty jealousy from speaking his mind freely, for he will receive fair treatment at our hands, and he is quite sure to get at least as much information as he gives. Don't be afraid to air your own hobbies, nor to show up any that you think are being ridden too hard by the debaters of the Union.

* * *

* * *

* * *

Do we make Watchmakers Too Fast? You will find one answer under "Communications."

* * *

* * *

* * *

OUR Paris correspondent gives us some interesting extracts from a critical review of the American silverware exhibits at the Paris exposition, by M. Falize, one of the judges in this department and a recognized authority in France. Eulogy would be more correct than criticism, perhaps, for M. Falize seems to have been so overcome with pleasurable amazement at the novelty of the display, that he could formulate no judgment. He evidently finds himself in the presence of an entirely new, and to him, somewhat chaotic school of metal work, which leads his fancy astray and upsets all his critical canons. In the lavish wealth of the motives and the boldness of treatment, he sees much promise in this young prodigy from the western hemisphere, yet he is somewhat fearful of its future. Unnecessarily so, it seems to us. In the natural course of development our artisans will soon rid themselves of the foreign affectations and other incongruities that now mar their work, and evolve a harmonious and characteristic national style, broad and cosmopolitan, but none the less our own. Still, it is highly gratifying to find in this eminent French critic so true an appreciation of our handiwork.

* * *

* * *

* * *

Look out for new features in our next.

THE question, "Do we make watchmakers too fast?" may be answered in a paradox. We turn out poor ones too fast and good ones too slow, that is, we have been making poor watchmakers because we lacked the facilities for making better ones. Haste and superficiality have been characteristic of all our education, both general and special. Compare the training our watchmakers have received with that afforded by the horological schools of France and Germany. The apprentice system is antiquated, and the factory system is inadequate to produce skilled watchmakers. Both must be superseded by the horological school—in fact, they are already superseded. The horological school furnishes the readiest means for the average student to obtain a broad, general knowledge of his craft. But, be it remembered,—superficial theory is no better than superficial practice.

* * *

* * *

* * *

How do you like our new style of advertising?

* * *

* * *

* * *

THE business man who can by any possibility arrange it ought to take a vacation every year, throwing all care to the winds for the nonce. We are aware how difficult it is for many to tear themselves loose from the engrossing duties of modern mercantile life, but if the hygienic benefits of a complete change of scene for the tired brain and overwrought nerves were generally recognized, many more of the slaves of business routine would find time to get it. Hay fever, that annual visitant, has proved a blessing to many persons because it compelled them to seek a change of climate at the same season every year. Of two business men of the same age and physique starting out in life together, let one take an annual vacation of from two weeks to a month and the other bind himself to his task the whole year through. The one who is wise enough to apparently sacrifice his business interests for a short time and seek pleasure, will accomplish more than the other and with far less friction, and will have better chances of attaining to a serene and healthy old age. The broken down old men, as a rule, are those that didn't take vacations. Variety is not only the spice of life; it is the fount of life.

* * *

* * *

* * *

Call the attention of editors of your local papers to "Elsie Bee's "Rambles Among the Jewelers," and have the items reprinted. It will increase your trade.

* * *

* * *

* * *

OUR able contemporary, the *Watchmaker, Jeweler and Silversmith* of London, has, in a recent number, some very interesting editorial comments on the present condition and tendencies of the jeweler's art in England. After quoting an opinion that the French goldsmiths have given up symbolic art, in favor of æstheticism, the editor says:

"In what direction are we on this side of the channel trending? In so far as regards the work of the goldsmith proper, superficial observation would lead one to think that the tendency now-a-days is entirely in the direction of symbolism, to the neglect, perhaps, of other qualities in the work produced. But in this respect the goldsmith is not altogether a free agent. Municipal, ecclesiastical, masonic, and other badges and insignia are of necessity symbolical, whatever be the meaning of the emblems embodied, and whencesoever the derivation (whether they are emblematical of amusements of clubs or official positions, or are merely the outward and visible manifestations of esoteric imaginings on the part of the authors or designers), and in comparing modern French and English art productions with one another, we would more especially suggest a consideration of the difference between the smaller jewelry produced in the two countries.

Let the intelligent jeweler make a round of visits to the principal London shops and inspect the various specimens of, say, diamond mounted work, for example, and then (after he has got what should be a good idea of the style of work manufactured by some of our leading firms) let him visit the French section of the Paris Exhibition that is devoted to jewelry; or, if he cannot manage this, let him do the next best thing for the purpose, and read up the published accounts of that exhibit. We venture to say that, in either case, the result will be of the nature of a revelation to him in one respect at least, and that will be in the opening of his eyes to the immeasurable distance the French are ahead of us in the æsthetic qualities of their work. In the first case he will see (with a few notable exceptions) beautiful stones, splendidly mounted in a number of geometrical designs, all of which are more or less repeated in the larger objects, but as for any combinations

of color or artistic designs—none. A few colorless sprays of the Prince of Wales' feather type seem to be the uttermost limits to which our manufacturers are permitted to stray. In the French jewelry, on the other hand, fancy appears to run riot; birds, beasts and fishes, flowers and fruit, in every imaginable combination are to be seen, colored stones and enamel being largely drawn upon to carry out the effect.

"The masterpieces of Bapst, Richstadt, Boucheron, and others would indeed be a revelation to some of our home workers who have no conception of anything beyond what can be seen in Bond Street. We ask a leading manufacturing jeweler: Why is this? Cannot English jewelers turn out work of a similar character, or is it that they are not content to take a back seat in the matter of complicated design, and acknowledge the superiority of the French artists? "No, it is not that," is the reply, "nothing but work of the set kind alluded to will sell to the great majority of English shopkeepers, and the public look upon anything else as *outré* and vulgar, and won't wear it." *Voilà tout*. The sooner the public are educated up to the point of not regarding the wearing of artistic jewelry as *outré* and vulgar, the better it will be for the trade here, say we, and we should strongly advise English jewelers to make the attempt at once."

These remarks about the inferiority of English jewelry designs must be acknowledged just, and the candor with which the admission of inferiority is made proves that if the English trade are as fair-minded and as open to suggestion as the *Watchmaker, Jeweler and Silversmith* is, this inferiority will soon disappear. When our contemporary says that "fancy appears to run riot" in some of the conceptions of the French jewelers, it touches what in our opinion is a frequent fault in the Parisian novelties of the day. They are too often incongruous or in bad taste. The bizarre, or the *outré* is attained at the expense of correct principles of taste. Skill and fancy it is true are displayed in nearly all their handiwork. This criticism does not apply to the best efforts of the French jewelers.

* *

* *

* *

What is the new Watchmakers' and Jewelers' Union? Read and learn for yourself.

DOES IT PAY TO BE HONEST?

THE writer recently heard a gentleman connected with the trade criticising some deceptive goods that had been brought to his attention, and after some remarks in connection therewith he concluded by saying: "It does not pay to be honest in trade." The remark was not intended in earnest by any means; but it was made to illustrate the fact that shoddy, deception and fraud are too often attended with pecuniary success in the transaction of business in these days. Adulteration of quality is the most common form that these dishonest practices take. There is scarcely anything of daily use or consumption that has not been subjected to some process to degrade its quality. The fresh creamery butter, for which we pay the grocer a liberal price, is apt to be composed mostly of oleomargarine; the best lard purchased ordinarily is made from cottonseed oil, and almost the entire quantity of olive oil used in this country is also the product of the cottonseed. Flour, sugar, and all those articles which are counted as necessities of life, partake more or less of foreign substances. The pepper, mustard, and all spices and condiments, possess but a small fraction of the genuine articles. And fortunate it is if the foreign portions are of a harmless nature. We know that in Brooklyn there are factories that make a business of grinding up cocoanut shells into a powder for mixing with pepper, ginger, and other spices, while the production of numerous other articles for degrading the quality of standard goods is no longer a secret, but is boldly advertised and proclaimed. Some of these industries have met with great success, and the fraudulent products of their factories find ready sale to their profit. Indeed, so common has become this practice of adulterating food products that one no longer expects to buy a pure article but takes whatever is presented to him under an attractive label. Everybody complains in one way or another, but there seems to be no remedy. State laws have been enacted to prevent the adulteration of certain articles of food; but they are powerless to remedy the evil for the reason that no proper provision is made for the enforcement of such laws. Our readers will all doubtless remember the hue and cry that was raised against oleomargarine and the legislation that has been had; but yet oleomargarine factories flourish and their products are sold as pure butter even by the best grocers. Similar laws have been passed to prevent the adulteration of milk, yet it is a question if any pure milk ever reaches this market. Milkmen have been convicted under the law, paid their fines and returned at once to their old practices. But it is

not alone in food productions that this degradation of quality is to be found. It extends to almost everything that anyone has occasion to use, either in his domestic circle or in his business pursuits. Even printers' ink is no longer the genuine jet black substance that it used to be, and the ink and pencils with which we write are sometimes frightfully and flagrantly bogus.

It is a question to what extent this general proclivity for adulteration is injurious to the public. While there can be no excuse for a grocer knowingly selling a cheap article of oleomargarine for a high-priced quality of butter, yet oleomargarine, being not only harmless but healthful, if sold for what it is and at a low price is doing a good work in providing a cheap article of food. So in the jewelry business. If rolled plate goods are sold for genuine gold, a fraud is committed; but at the same time rolled plate goods have their place and have enabled the masses to indulge in the luxury of personal decorations that would have been impossible to them had they been dependent entirely upon solid gold. It is only where deception accompanies adulteration that the public is defrauded and a crime committed. All this degradation of quality comes from excessive competition and from a demand on all sides for cheap goods. Dealers find that to hold their trade they must undersell their neighbors, and so they ask of the manufacturers to produce a class of goods that can be sold at lesser prices. Thus adulteration of the genuine is demanded and even made a necessity, because when one manufacturer so cheapens his goods so as to undersell his neighbors, others must perforce follow suit. It is a frequent remark that clothing, groceries, and the general necessities of life were never cheaper than they are now. But they are cheaper because the quality has been impaired, for the genuine article possesses such actual value that it is scarcely possible for it to fluctuate much in price. The prices of staples from year to year for a series of years will be found almost uniform; but the prices of the products derived from these staples are constantly on the decrease. Part of this decrease is due to better facilities of production; but nevertheless the processes of adulteration are responsible to a very great extent for the fall in price. In the jewelry trade genuine goods have intrinsic value as great, probably, at the present time as it ever was. Such goods, by reason of improved machinery, etc., may be produced now somewhat cheaper and so sold for a less price than formerly; but the value of the actual material of which they are composed is substantially the same as it was many years ago. As regards goods of actual intrinsic value, when the price to the consumer is lessened there must be either a reduction in the labor that produces them or improvements in the methods employed in their production, for the actual values are still there. It is only when degradation of quality steps in and palms off an inferior metal for the genuine that fraud participates in the transaction. That this is done to some extent is unquestioned; but that it has become so general, as is charged, we believe to be untrue. Manufacturers are not lost to all sense of honesty by any means, and the jewelry trade is certainly composed of men who rank as high as any others in points of honesty and integrity. There are many of them who would close up their business entirely rather than consent to a swindle of the nature indicated. They may make cheap goods; but in placing them upon the market they affix to them the price that should attach to cheap goods, and do not attempt to palm them off as genuine, Simon-pure articles. One reason why the trade is charged with degrading the quality of its wares lies in the fact that persons entirely outside of the trade purchase cheap goods, paying for them the price of cheap goods, and subsequently retail them as the genuine article. The great bazaars of the larger cities and the outside merchants who carry, for special purposes, small lines of jewelry, are largely responsible for this. Not being legitimately in the trade and having no reputations as jewelers to make or lose, they are at liberty, from a business standpoint, to do what they please with the goods they purchase. And if they choose to buy plate goods and sell them as the genuine article, no redress is to be obtained by the swindled purchaser. It is very different with the legitimate dealer, whose reputation in the community in which he lives is at stake, and he must guard it as religiously as any other business man. If the experience of the jewelry trade could be spread out before the present representatives of it, we do not question that the result would prove that honesty *does* pay, because the most successful dealers are those who have dealt honestly and fairly with their customers, and so established a hold upon public confidence that has brought them the reward which virtue is always said to bring to those who practice it. In these days of cheap goods of all kinds, it is very easy to cry "fraud" and "swindle;" but at the same time we believe that there is to-day quite as much honor and morality in trade as there ever was, and that dishonesty receives its merited rebuke quite as frequently and decidedly as ever.

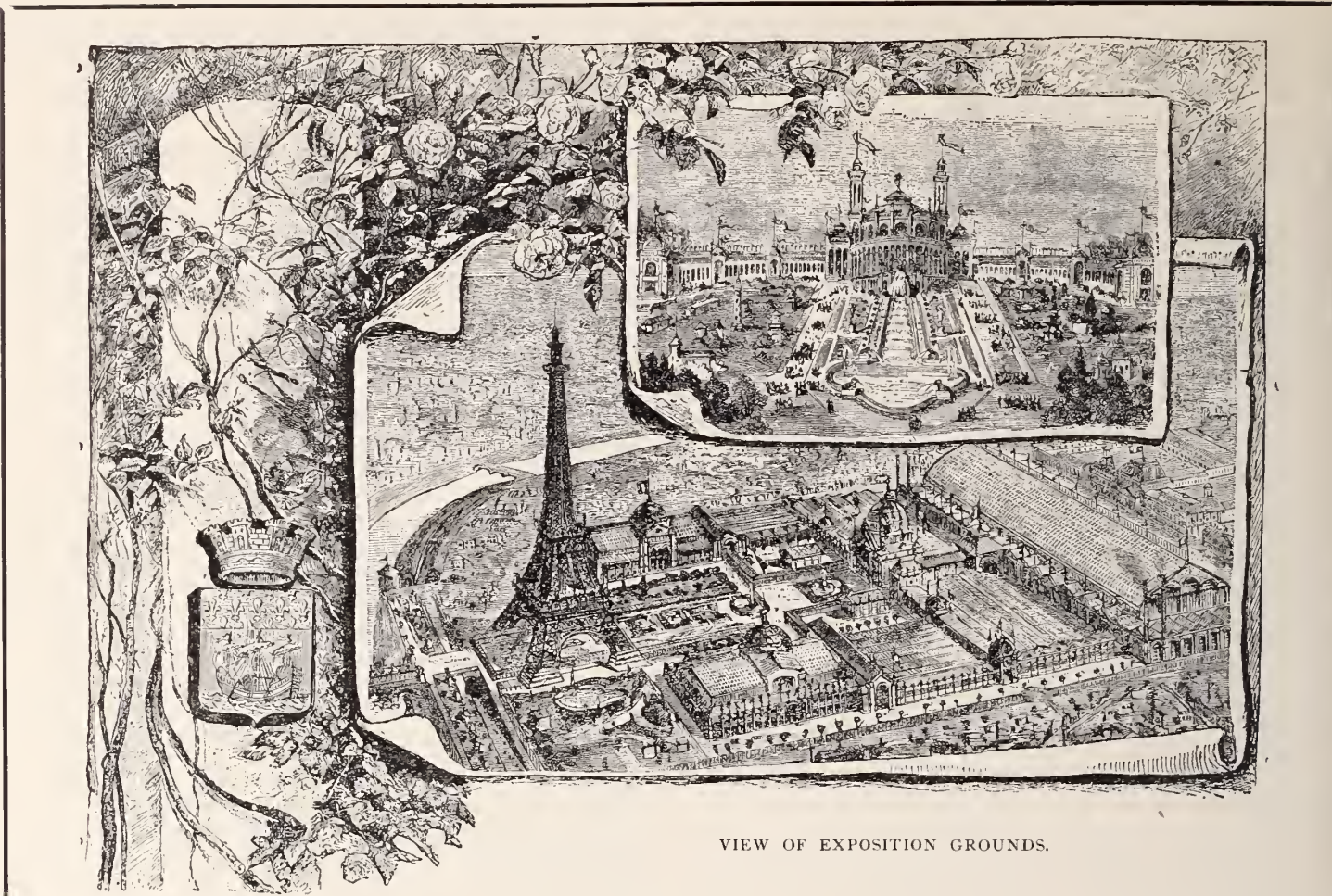

VIEW OF EXPOSITION GROUNDS.

Glimpses of the Exposition.

[FROM OUR SPECIAL CORRESPONDENT.]

PARIS, Sept. 15, 1889.

M. FALIZE ON THE AMERICAN EXHIBIT.

Your readers may be interested in the following extract from an article published in a well-known artistic periodical by M. Falize, the *rapporteur* of the jury for silverwares :

"Among foreign exhibitors, Americans alone have made a serious effort. They are coming to the front, and although their works are criticized, they deserve to be studied. My present position does not allow me to express my opinion on their merits ; but I will try to define the new taste discernible in those works. Many people rebel against it ; most of those to whom I have spoken of it do not admit of that way of treating silver. The colors, the shapes, in fact everything seems strange to them. Their eyes accustomed to rest on symmetrical lines and architectural mouldings, wonder at those bold rotundities, at those independent shapes, reminding one of peculiar fruits, or even showing no imitation of anything to be found in nature. No rough part, no sharp line is visible. The metal is so smooth that it seems to invite fingers to caress it. Etching and chasing have been used together to swell out some delicate embroideries, or to trace open different designs for niellos, alternating with plain surfaces. It is incrustated with enamel or inlaid with various metals, not according to the rules of our European styles, but with a harmony of opposed shades of colors (inspired by the numerous tinges of leaves, the diverse hues of flowers) which are like intelligent stains (*sic*) watersilking silver, etc."

This superabundant description, which runs through many more lines, coming from M. Falize, who is considered, in France, as the highest authority on gold and silversmithing, is very significant. M. Bapst, his distinguished partner in business, deals more especially with old curiosities of art of whatever description, and although he belongs to an ancient family of Royal Jewelers, he has allowed his

taste to lead him into many different fields. Therefore we may well say that M. Falize's opinion on the present subject is of the highest worth. Our eminent critic certainly tries to cool down towards the end. He says that French people will not easily admit of a style which violently upsets all their notions about silverwares and jewelry, but in spite of himself a deep admiration possesses him, and bursts through in spite of his evident effort to escape from the spell. Here is the end of the paragraph :

"Gold takes the shape of the most complicated of orchids. Precious stones and enamel give to those mysterious flowers appearances which act on us in the same way as strong scents, that charm us into sleep or maybe unto death. Never was the art of frightening or enchanting carried so far." Now it is utterly evident that M. Falize could not quietly and deliberately come to adopt such a tone. If it may be urged that his duty compelled him to examine closely the American Exhibits, it is perfectly clear that he has been fascinated by them, and the repeated study of those original pieces seems to have deeply impressed him. Although a critic of unbiased mind, his special education and strong likings have given him a decided preference for works thoroughly harmonious and well balanced in all their parts, according to the rules that have given birth to our historical styles. Therefore he is actually frightened, as he says, by these offspring of a new art, and dares not (must not) contemplate the possibility of its ever becoming a ruling one. M. Falize will, no doubt, inwardly acknowledge that it is, so to speak, the splendid outbreak of an Oriental Renaissance, whose exuberance may, in course of time, be checked and regulated so as to suit his sober taste.

STANDARD TIME SERVICE AND SETH THOMAS' CLOCKS.

I have the pleasure of giving you here an illustration of the United States Naval Observatory Time Service exhibit that is made up principally of Seth Thomas' clocks. In my last letter I gave a descrip-

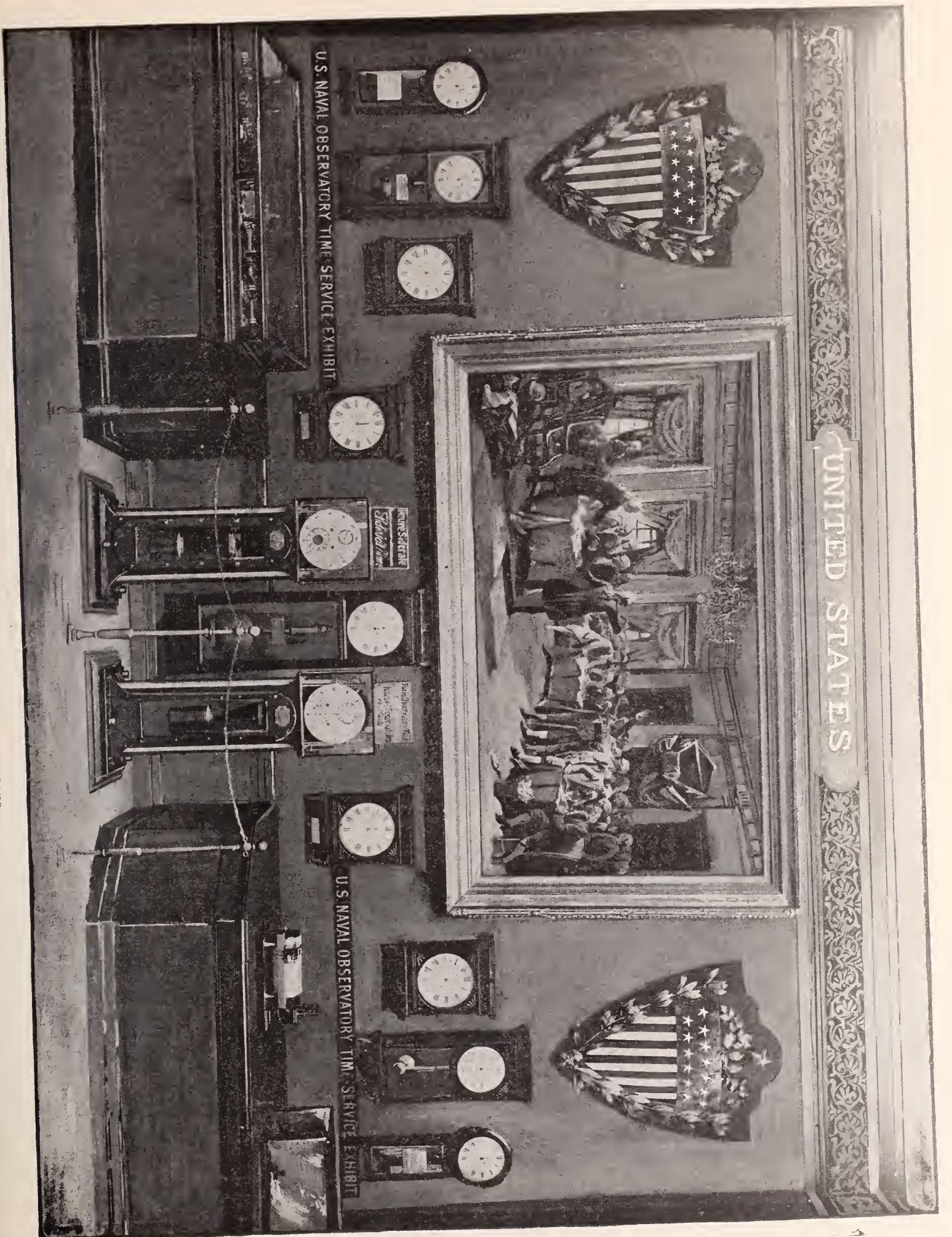

STANDARD TIME SERVICE—SETH THOMAS CLOCKS.

tion of the exhibit as well as an interview with W. F. Gardner, who has charge of it, in which he gave me a complete explanation of the system. The exhibit is no doubt one of the most striking in appearance in the American section, and I see none which can be compared to it in the other courts. The tasteful groupings of the clocks, as you will note, gives a peculiar impression of pleasure to the mind which is strengthened by the sober outlines of the cases. One of the two standard clocks in the center shows the siderial time, while the other, the Paris Observatory time. These two standard clocks belong to that grade of the company's manufacture known as precision clocks, which were originally designed and built under the scientific supervision of Dr. Leonard Waldo, then astronomer in charge of the Horological Bureau in the observatory of Yale college, but now electrician for the Bridgeport Brass and Aluminium company, and which since their introduction in 1888, have become well-known throughout the United States and Europe. I am told that these clocks had been in process of construction for several years before their introduction; that in their manufacture every feature of design and work-

by visitors. The neat and elegant appearance of the specimens displayed in most glass cases, and especially in those of Geo. Agassiz and of E. Francillon, together with the admirable finish of all the inside parts, roused in me the desire to know all about the making of those time pieces. Therefore I paid a short visit to St. Imier, a picturesque village of the Berne district, and entered the manufactory of Longines, established in 1832. It has constantly increased ever since. In 1866 it was found necessary to rebuild the whole place and to adopt an entirely new system which would allow the whole work, from sketching to finishing, to be done at the one factory.

The Longines employ 400 workmen and women who make 50,000 watches a year. The workshops resemble glass houses, and, in consequence, the benches receive a splendid light. Besides, the manufactory is situated in a healthy neighborhood, which places artisans in the very best condition to do their work properly.

Although everything is done by mechanical process, yet intelligent and clever artisans have to be employed, as, in spite of the

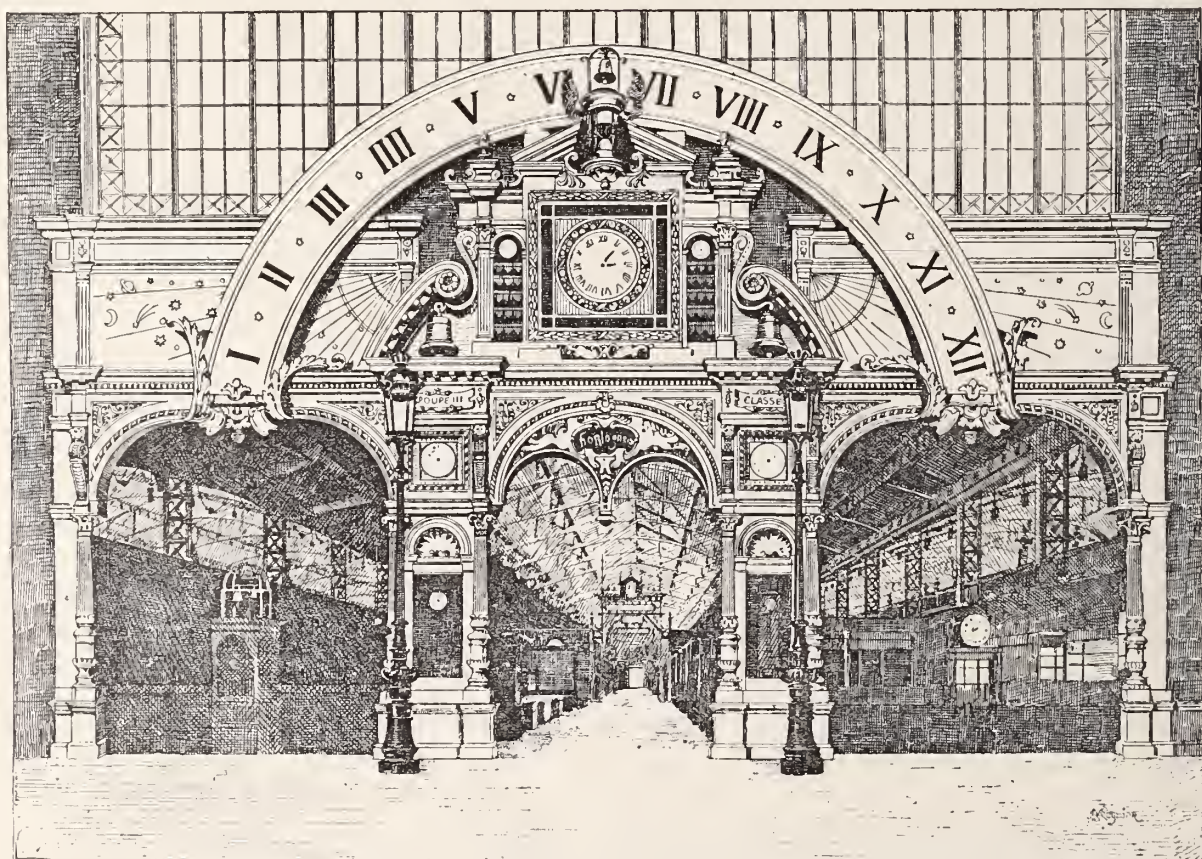

ENTRANCE TO THE HOROLOGICAL SECTION.

manship is made subservient to the principal idea of obtaining as high an accuracy in their time measuring qualities as the existing knowledge of horology will allow. The name "Precision clocks" was adopted in the sense in which that term has come to be understood in modern science as indicating a time measuring instrument entirely above the line of every day accuracy and intended for those who desire for purposes of scientific work, or for watch and chronometer rating, or as a standard timepiece for local reference, to have a clock of extreme precision.

The other clocks are the ordinary Seth Thomas' regulators, too well-known to require any special mention or praise from me.

THE EXHIBITS OF GEO. AGASSIZ AND E. FRANCILLON.

To get an exact idea of the Swiss exhibits of watches, it is almost necessary to go to Switzerland. If you apply to one or several of the Swiss agents at the Exposition, you may possibly obtain from them some of the details you require, but it will not be very easy, as their explanations are bound to be frequently interrupted

perfect regularity of the machine work, there may be found, here and there, a flaw or a defect, which, alone, a skilful hand can correct. If we cannot help admiring the beauty of the movement, what shall we say about the decoration, whose variety, being applied to so limited a field as a watch case, is simply wonderful. Besides a great many designs done with etching, engine-turning and chasing, we notice some delicate ones obtained with a rolling or stamping process. Beautiful samples of all these artistic patterns are shown in the unpretending glass case of E. Francillon (of Les Longines) at the Exposition. I have remarked also some exquisite miniatures in enamel, one of which covers a surface no larger than that of an ordinary stud. Geo. Agassiz exhibits a great variety of movements or separate pieces which can well bear examination through a magnifying glass. It is impossible to see anything more perfect in that line.

I shall visit the Swiss section again to have a look at musical boxes, etc.

THE GORHAM MFG. CO.'S EXHIBIT.

The Gorham exhibit still continues to elicit expressions of unqualified praise from all visitors who see it, and perhaps no set of theirs excites more admiration than the repoussé dinner service, of which the pitcher is here represented, and which I think, has not been heretofore described. Massive, yet delicate, the beauty of execution of the numerous pieces is wonderful. The design is distinctively East Indian, the main idea being a convolution of ram's horns, and the repoussé decoration is elegant in every particular. Though the style and character of ornamentation are similar throughout, the variety and uniqueness of shape of the tureens, salad dishes, sauce and gravy boats, and the other pieces, to the number of fifteen, produce a charming effect. It is undoubtedly one of the most elegant services of the same number of pieces ever produced in America, and has been the subject of a great deal of comment on account of its high art character.

The beauties of the Louis XVI style of decoration are charmingly applied in the table service, of which the tureen here given is a representative piece. Elaborate yet beautiful, this set has attracted the attention and excited the admiration of thousands of visitors.



PITCHER OF EAST INDIAN DESIGN.—GORHAM MFG. CO.

The design of each piece while preserving some of the characteristics of the other, possesses merits of its own, and with the chasing, is a striking example of remarkably fine workmanship. The characteristics of the style of art followed are faithfully and distinctively preserved, the lids, arms and legs being treated in the same manner as the bowls.

Among the more prominent individual pieces the black coffee muffineer and pitcher, illustrated in this article, claim especial attention. They are beautiful examples of fine silver work in repoussé, the pitcher noticeably being a remarkable piece of clearly defined chasing, showing a goodly amount of undercutting, the highest branch of the chaser's art. Note the quaint outline of the coffeepot; no model is followed, originality being sought and attained with charming effect.

The fallacy of the opinion prevailing in Europe, that the superior products of America, are copies of European achievements is daily becoming more apparent, owing to the complete originality of the Gorham and other displays.

IN THE FRENCH JEWELERS' COURT.

In the jewelers' court, the bijoutiers, or workers in metals exclusively, find it very hard to draw the attention of visitors fascinated by the displays of the joailliers (employing precious stones), yet the former are a very interesting class, who try their very best to check



INDIVIDUAL PIECES.—GORHAM MFG. CO.

the all-invading tendency of precious stones (real or imitation) and revive the fashion for plain or worked gold. I am afraid that their case will prove a hopeless one with the high spheres of society, but they still preserve a firm hold on the *petits bourgeois*. Among the exhibitors in bijouterie, Messrs. Gross, Langoulant & Co., are prominent. I have noticed in their display more than three hundred different models of gold chains, bracelets, lockets, brooches, and trinkets of all kinds, out of 350 items. They make a specialty of cheap, yet good jewelry which is said to meet with a large demand from some foreign countries. They have a necklace in Indian style which weighs only 80 grammes. But the real wonder of lightness is a chain of 87 grammes, which it would seem ought to weigh 160 grammes if it were hollow, and 540 grammes if it were solid.

The most remarkable display in the jewelers' court is by far that of Messrs. Bapst and Falize. The numerous pieces of their exhibit are as many different specimens of historical French styles of jewelry and silver or gold works of art shown at their very best. We see there the reproduction of Marie Leczinski's cancan necklace (of which you had an illustration in Paris Gossip of last March) with a ruby as center stone of the three groups and the real Sancy as pendant. Then we notice the *neud papillon*, a light and graceful diamond bow-knob with a large pear-shaped pearl at the base, being a copy (very much superior to the original, I believe) of that made

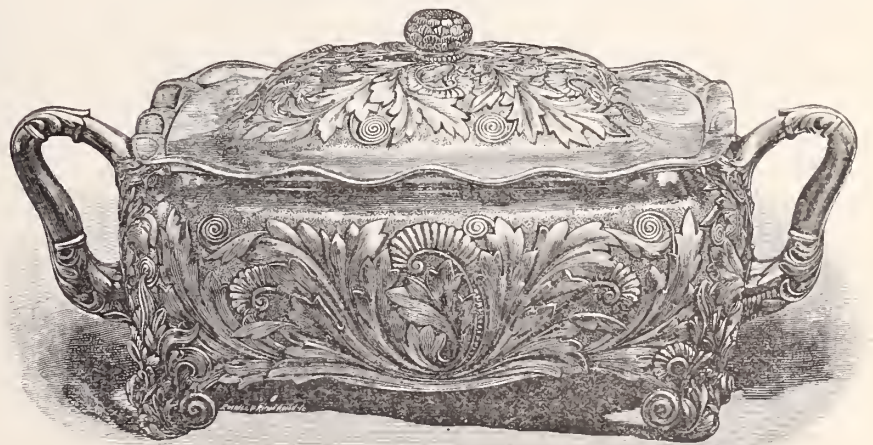

TUREEN IN LOUIS XVI. STYLE—GORHAM MFG. CO.

for Anne d'Autriche, Queen of France, in 1650. Next, we are attracted by an exquisite piece of jewelry, reproducing the well-known *panier fleurie*. It is a bewitching little basket with flowers drooping on each side in half relief—the whole being made of



CORNER OF CHRISTOFLE & CO.'S (PARIS) EXHIBIT.

diamonds, rubies and emeralds, lightly mounted on gold. This masterpiece of workmanship is supposed to be an exact copy of the one made for Queen Marie Antoinette by M. Germain Bapst's successor.

REMARKABLE FRENCH SILVERWARE.

Now, if we step into the French section devoted to silversmiths, and stop before any one of the exhibits, we shall notice at once that, the key-note is Louis Quinze for ever. I have told you already the causes of it. All I need say at present is that the effect is very pleasing, as this style admits of unlimited fancy; those unending variations on the same pretty tune do not appear so monotonous as might be expected. The illustration (reproduced here) showing a corner of Christofle & Co.'s exhibit gives a vivid impression of what I mean, with its candelabras, the jardiniere and the fruit stands, all supported by figures in different attitudes. The silver tea set resting on a table (as shown here) is a great deal more sober in its details. Now if I may offer an opinion on Christofle & Co.'s exhibit I confess that although I greatly admire it, I do not find those pieces superior at an artistic point of view to those of 1878. If (to help my memory) I look at good illustrations of the principal pieces, which they exhibited then, I come to the conclusion that they have not, this year, made any advance. I acknowledge that they have always employed the best French artists for the modeling of their pieces, and therefore may have attained long ago the highest degree of perfection within their reach.

IN THE BRITISH QUARTER.

In the British Court, where jewelers and silversmiths are comparatively scarce, one glass case has particularly attracted my attention; I mean that of James Dixon & Sons, of Birmingham. The display is far from being a large one, considering the kind of articles exhibited; but yet, in looking it all over, one gets a thorough idea of the true English silver and silver plated wares. Those claret jugs, liqueur-stands, biscuit caddies, ice pails, tea sets, cruet stands, candlesticks, smoking lamps, etc., are a proof that the real characteristic of the English style is fitness applied to an imperious longing for



EXHIBIT OF FRENCH SILVERWARE.

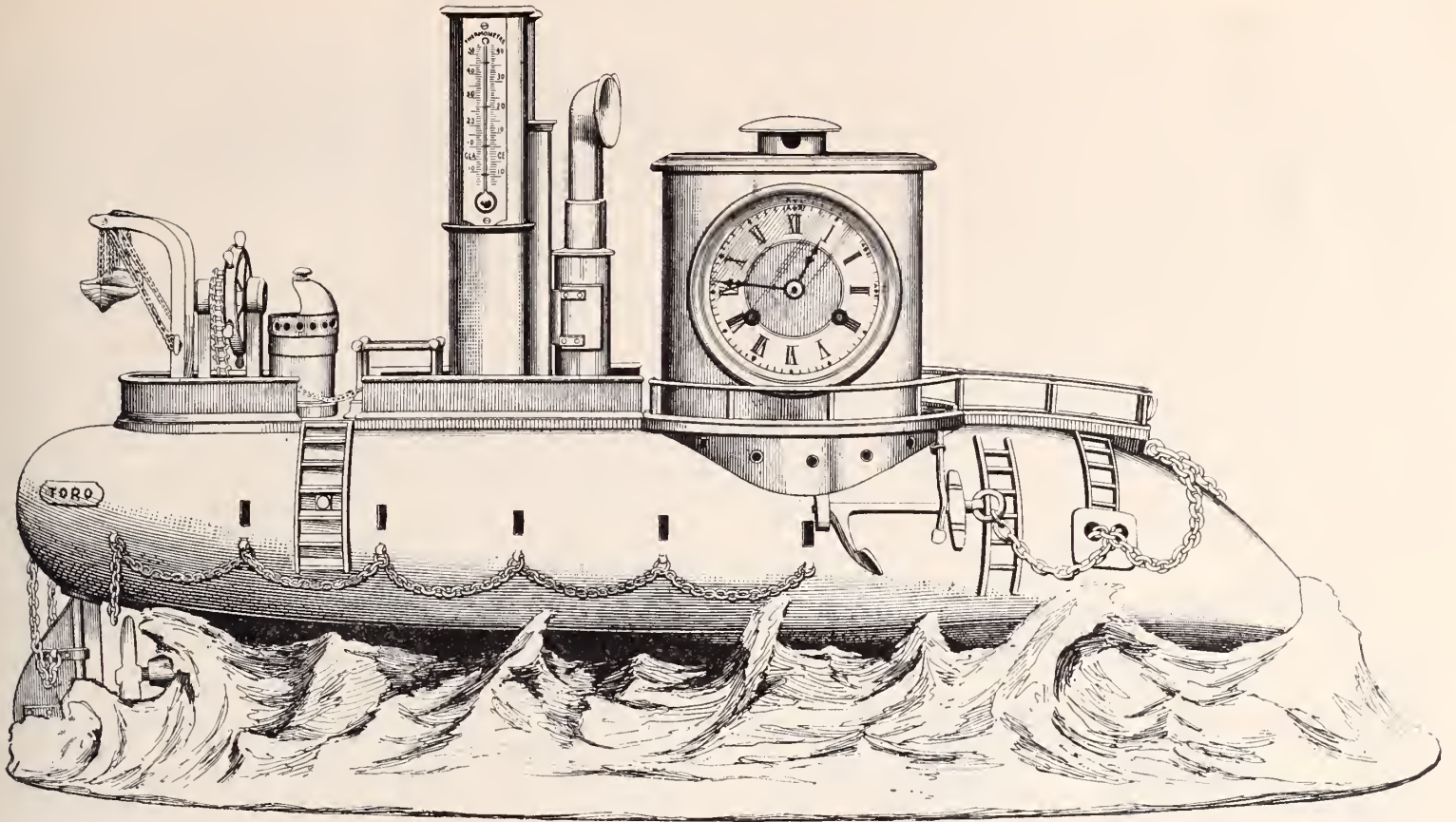

MECHANICAL CLOCK, MADE BY BORIUS.

comfort. The present illustration showing you a group of those articles fully confirms this statement. A bit of fancy appears here and there, but imagination is never allowed to transgress some especial limits prescribed long ago for admitted shapes and patterns.

BORIUS' MECHANICAL CLOCKS.

The mechanical clock representing one of Borius' latest original clocks hardly requires that I should describe it. These mechanical clocks are faithful copies of well-known mechanical works. All I need say about them is, that although constructed with the greatest care, they appear to be of a rather high price.

THE EXHIBIT OF AMERICAN PRECIOUS STONES.

If you go through the American section at the Universal Exposition, past the Palais des Arts Liberaux, you must not fail to stop before a circular glass case containing a marvellous collection of precious stones of North America. This exhibit, connected with Tiffany & Co's., has been organized by Mr. George Kunz, special agent for the Mineralogical and Metallurgical Exposition of the U. S. Visitors will see there highly beautiful gems, and obtain a most exact idea of the mineralogical wealth of North America, so rich in all kinds of products. The magnificent collection contains splendid



ENGLISH SILVERWARE, JAMES DIXON & SONS, BIRMINGHAM.

specimens of native crystallized gold from California, fine diamonds and unrivalled rubies. One of these, matchless in point of color and transparency, comes from North Carolina, Jenk's mine, Franklin, Macon County; some of the rarest sapphires, beautiful emeralds and tourmalines, pieces of rock-crystal as transparent as the purest water; peridots, amethysts of a deep, yet clear, violet; obsidiennes, gadolinites, and turquoises. These have been used in North America for ages past. This collection contains some very curious specimens of Indian jewelry. A few of them are reproduced here. Fig 1, shows a necklace consisting of circular pieces of perforated turquoises held together with a thread. Fig. 2 (full size) is a tiny imitation of a prairie dog, cut out of white marble, and inlaid with a couple of turquoises, forming the eyes. The animal's neck is circled with a necklace from which hangs a circular mother-of-pearl piece. This is an ancient luck-bearer considered by Pueblo Indians as causing a beneficent rain to fall. No. 3, is a silver ring with a turquoise in the bezel. No. 4, is a turquoise heart with a small ring fixed on it. This collection contains a great variety of curiosities of the same

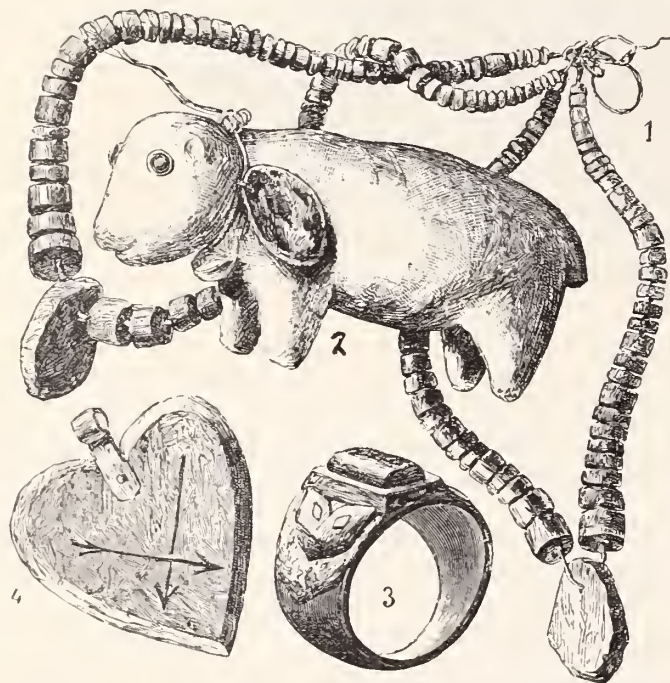

INDIAN JEWELRY.

kind, besides beautiful samples of pyrites, malachite, azurites, ambers and other precious stones.

J. F. FRADLEY & CO.'S EXHIBIT.

J. F. Fradley & Co's. display of gold headed canes is certainly the most elegant and the most complete ever seen here. It is surprising that so many shapes and designs could be devised for an article of use in which fitness must be the over-ruling consideration. The wonderful richness remarkable in all these cane tops does not interfere in any way with a comfortable handling of them. How perfect is the work of the numerous patterns so entirely different! Here is a rope closely twisted; there a knot beautifully formed; then appears a square of basket work, delicately treated. This one shows a tiger's head full of life, and that one the vivid image of an eagle. Dogs' heads, horses' heads, etc., are reproduced to a nicety. The thoroughly artistic arrangement of all these chased motifs whose reliefs are so well proportioned gives a most pleasing effect. Some have gold quartz heads framed in worked gold, which looks as neat and as refined as the most fastidious taste can desire. Now, if we consider the canes themselves we find no less a variety. We have to admire in turn, rose-wood, snake-wood, ebony, malacca, etc. The public cannot resist the attraction and the more they look into the details of all those specimens the more they are fascinated by them. I am glad to say that Fradley & Co. will have no reason to regret their participation in our great International Exposition.

FRANCUS,



[FROM OUR SPECIAL CORRESPONDENT.]

THE GRIM REAPER THINS THE RANKS OF CHICAGO JEWELERS.— FAILURES, OLD AND NEW.—FROM OUR OBSERVER'S NOTE BOOK.

CHICAGO, September 20, 1889.

The Chicago jewelry trade has met with two irreparable losses since our last letter; not that there has been any financial depression nor that any business failures have affected them, nor that they have had occasion to complain of dull trade. The grim visitor, who respects neither persons nor any of the hopes and plans of our frail humanity—Death—has made a wide breach in the rank and file of Chicago's jewelers. The founders of two of Chicago's representative establishments have been called to their last account, leaving behind them as the one consolation for their families and their friends, records of successful integrity and a memory, which is an example to all their fellows. The first to leave was Elijah Peacock, the founder of the establishment to which his son, C. D. Peacock, succeeded. Following soon after, the same dread summons came to Sigmund Hyman, who in 1866, founded the jewelry business latterly conducted under the name of S. Hyman & Co., and now to be conducted by the two sons of Mr. Hyman, associated with Mr. Berg, who has been a member of the firm since 1876.

Naturally the sensation of the month was the assignment of the Aurora Watch Co., on the 9th. The latest estimate places the liabilities at about \$200,000, and the assets at \$210,000. Truman H. Day, the secretary of the company, who was first appointed assignee, has been succeeded by a representative of the creditors.

The Aurora Watch Co. was organized in 1883, Morris Wendel of the Chicago establishment of Chas. Wendel's Sons, being the originator of it. The capital was \$250,000 and the officers were E. W. Trask of Aurora, President; Albert H. Pike of Quincy, Vice-President; Morris Wendel of Chicago, Treasurer and Business Manager; George T. Johnson and M. Hoffman of Quincy, were Directors. The city of Aurora at that time gave to the corporation valuable real estate, upon which it built well appointed works, and the first watch movements were put on the market in the fall of 1884. Mr. Wendel retired from the company not long after its inception, and the plan, which at first was to sell to one retail dealer in each town, who would become the sole agent, was then changed, and from that time they sold to the jobbing trade more generally. The company had a capacity of one-hundred and fifty movements a day, and employed a large force of workmen, to whom, it is said, \$15,000 is due. The closing of the factory was chiefly occasioned by the large amount of the watch company's paper held by the four banks in Aurora, and the two at Quincy, and judgments amounting to \$32,000 were entered against the company by these banks previous to the assignment.

The cause given for the failure is the attempt to do too large a business on the capital invested. Previous to the Max Young failure the company was obliged to accept \$12,000 of his notes, which, by reason of preferences given, are now absolutely worthless. The factory recommenced manufacturing by order of the court last Monday, and J. H. Weber, the superintendent, says it will be kept running until reorganized with additional capital.

There is not much to be added to what was said in our last letter respecting the affairs of Max Young. At present the sheriff and assignee are each in possession, the sheriff having charge of that portion of the stock which was attached before the assignment was made. It is stated here that the creditors in New York city and the East object to the selling of the stock, which was advertised to take place

some days ago. Mr. Young himself wishes the stock sold and the affairs wound up.

The *Chicago Herald* has devoted considerable space during the past month to the Wisconsin Pearl Fisheries, so called; but there is a great deal more nonsense than truth concerning the wonderful discoveries alleged to have been made, and although it is a fact that one Chicago jeweler has bought several thousand dollars worth of these pearls, it is equally true that a great many of the farmers are fooling away considerable of their more or less valuable time in digging up the mollusks from the Wisconsin streams. If they will take the advice of your observer, which is only given after a careful study of the whole situation and a sifting out of the facts from a great deal of chaff, they will find more profit in making preparations for other crops than in continuing their digging for pearls.

A Chicago man paid \$500 for one of these Wisconsin pearls which is the highest price thus far reported. The jeweler who made the sale had paid \$250 for it and the pearl dealer paid the finder \$75, but this is the one exception, which but proves the rule that most of these pearls are of little or no value.

H. A. Spaulding, the head of our largest retail jewelry establishment, sails from Havre on the French line steamer, *Gascogne*, on the 28th of this month, and will reach Chicago, October 8th, having spent several months, as the representative of this State, at the Paris International Exposition. Advices from Paris tell the trade here that the Paris branch house of Spaulding & Co., has had a most successful and profitable business since the day of its opening, and that the American silverware made by the Gorham Manufacturing Company is having a great sale, both at wholesale to the Parisian jewelers and through Spaulding & Co. at retail.

The fire which occurred at the Exposition building on the evening of the 14th, gave quite a scare to Mr. Sercomb, of the Meriden Britannia Company, and to Mr. Forman of Spaulding & Co., each of whom hurried down to their respective booths at about eleven o'clock in the evening. However, although the fire occasioned no less than \$100,000 damage to exhibits in their immediate proximity, the little palaces in which these firms make such imposing displays escaped harmless and yesterday there remained scarce any trace of the blaze, which ate up a fortune in a very few minutes. The Exposition has had quite an increase of patronage from those whose curiosity led them to see what havoc the fire had wrought, and the doors have not been closed since its occurrence.

Chicago has reason to be proud of the collection of pictures filling the walls of the art galleries of the exposition, and scarcely less pride is taken in the really wonderful display of jewels and the examples of goldsmithing and silversmithing shown by Spaulding & Co. It surpasses anything of the kind ever seen here.

O. W. Wallis, who attended the G. A. R. encampment at Milwaukee, Wis., says that quite a little enthusiasm was occasioned by the presentation of two watches to the first regiment. The American Waltham Watch Company were the donors of one, for the largest number of recruits, and the other was given by the Elgin National Watch Company, for the second largest number.

Max Ellbogen returned from Europe yesterday, and as soon as he gets settled down to work, Mr. Stein, his partner will go to Mackinaw, hoping to leave his hay fever in that cool spot. The average man thinks it has been quite cool enough here for the last week. J. B. Mayo, of Mayo, Groff & Co., has returned from his European vacation. M. N. Burchard, who has been in Denver for awhile returned to-day.

H. S. Peck, of the Waterbury Clock Company, started from his home on the west side yesterday morning on one of the open cars that the street railway companies persist in running, to the general ill-health of all Chicago. About half way down an ague chill overtook him, and he says that he shook the conductor off the car, at least the conductor got off, and a little further along he shook the whole car off the track, at least the car jumped the track, and he cannot give any

other reason for it. Nor did he wait to ascertain any other reason, if any existed; a brisk walk of some two or three miles brought him to his business office, and he then shook himself out of his office into the boiler room, down in the basement, where he hugged the boiler all day, leaving it at intervals to wait upon some especially big customer, and then running down again. Mr. Peck's ague, however, has not killed his enthusiasm respecting the present and future demand for Waterbury clocks, and he is especially proud of the marble cased goods made by his company, which are now taking the place of the older fashioned iron clocks, and which cost very little more. These marble clocks do not average 15 per cent. higher in price, and as the retailer gets at least 35 or 40 per cent. more than he can for the iron clocks, he is joining hands with the company in pushing their sale.

The Gorham Mfg. Co.'s branch warerooms here are in receipt of their full line of fall goods, including a great many of the smaller pieces suitable for holiday presentation. It won't do any jeweler any harm to get a sight of these novelties, and if that is impossible, he should write for their description.

H. H. Walton, Western manager for the Meriden Silver Plate Co., is fixed just right for fall trade. With enlarged premises on a level with the street (Wabash avenue), attractively draped with plush and lace hangings, and filled with a remarkably beautiful line of the newest ideas embodied in silver plate, the trade can't escape him. Your observer admired, most especially, some silver-mounted lamps whose globes and chimneys were of cut glass. They cost from \$60 to \$100 each.

The Ansonia Clock Co. have an attractive line of colored bronzes, one or two pieces of which will help set off the beauty of any show window or wall case. Their cost is but little more than the same figures in the plain bronze.

Mr. Smith, of the Geneva Optical Co.'s Chicago house, was good enough to take your observer on a tour through their warerooms and factory a few days since. The stock of compound lenses carried by this company is something enormous, and with the aid of a special order case, which they furnish to the jewelry trade, any jeweler of ordinary intelligence can fill all orders satisfactorily, even for most difficult cases. These special orders are called prescriptions. When the blanks with which the Geneva Optical Co. supplies the jeweler are returned filled out, they are first recorded by the receiving clerks, and then are sent to the top floor of the building, where a large force of operatives attend to the filling of the orders with absolute accuracy. Your observer saw several hundred tools of different curvatures ready to hand for the concaving and convexing of lenses, and the whole establishment bespoke the success that this company are having in catering to the optical department of the jewelry trade.

Another interesting visit was made to the the establishment of L. S. Grout. He makes a specialty of every sort and kind of sign, which any jeweler can find use for. Mr. Grout endorsed the statement of the Geneva Optical Co. that every jeweler who pretends to be up to the times nowadays makes the sale of optical goods and eyeglasses one of the principal features of his business, and any number of spectacle signs of all kinds and sizes are displayed in Mr. Grout's sign works. Of course the familiar big gold-rimmed, white-dialled watch is most in demand as a sign, but there are also quite a variety of novelties in the way of watch signs, which enterprising dealers might do well to learn about by addressing a letter to No. 124 Dearborn street, this city.

The big beehive which appears in the advertisement of Lapp & Flershem in last month's CIRCULAR, has attracted quite a little notice here in town, and a leading dry goods house wishes THE CIRCULAR's permission to use the same idea in an advertisement for their house. Messrs. Lapp & Flershem are perhaps "the busiest jewelry house in America," as asserted on their nameless catalogue. At any rate, your observer can vouch for the fact that they are

working late every night filling orders, which is quite remarkable this early in the season.

The Theodore Kearney stock of optical goods and jewelers' tools which was purchased at forced sale by C. H. Knights & Co. some time since, has all been closed out and the store closed. It has been a profitable venture for the buyers.

C. H. Knights & Co. received a despatch the other day stating that Sumner Bros., of Cleveland, O., and local banks had closed up the establishment of H. J. Goddard & Co., at Chippewa Falls, Wis., on confessions of judgment aggregating several thousand dollars, and a telegram received by the *Chicago Herald* states that the stock was attached yesterday morning on an execution in favor of Messrs. Knights & Co. This telegram places the liabilities at \$18,000 and the assets at \$30,000. Those of the jobbing trade conversant with Mr. Goddard's affairs state that he probably carried a stock of \$15,000 or \$18,000. It is also learned here that "too much politics" has occasioned the failure, as Mr. Goddard, when he attended strictly to the jewelry business, always made money, and a year or two since was worth \$25,000 above all liabilities, but when he was sent to the State Legislature his business was neglected, and his failure results.

Other news throughout this State is to the effect that Thos. Pratt has removed his business to Washburn, Ill. Also that Cook & Sprague, of Hadley, Ill., have added jewelry to their stock of general merchandise. Sam Prager, recently of P. L. Bartlett & Co., of Elgin, is manager. The safe of Thomas Webb, of Peoria, Ill., was burglarized recently, the thieves being contented with the looting of several watches.

Prominent among the out-of-town jewelers, who have been seen on Chicago streets within the month, your observer has noticed: J. A. Walker, of Valparaiso, Ind.; C. S. Hayes, of Norfolk, Neb.; S. W. McArthur, of Streator, Ill.; Ozias Riley, of Champaign, Ill.; D. W. Terrel, of Long Mount, Cal; Mr. Greene and Mr. Smith, of the C. H. Greene Jewelry Co., Denver, Col.; Mr. Bazette, of Allegan, Mich.; Theo. E. Schleuder, Albert Lea, Minn.; Sam E. Hall, of Hampton, Iowa; Mr. Hickson, of Hickox & Hickson, El Paso, Tex.; Frank Carruth, of Plattsmouth, Neb.; N. V. Cole, of Michigan City, Ind.; C. F. Sischo, of Sioux Falls, Dak.; J. H. Crowder, Missouri Valley, Iowa.

THE CIRCULAR'S OBSERVER.

To Revamp Nickel Movements.

IT IS a great objection to nickel movements that they will occasionally turn brown; small round spots which are with difficulty removed, will sometimes come on them. These are verdigris, which adheres very tenaciously; it is doubtlessly caused by sudden changes of temperature and the corporeal exhalations of the wearer of the watch. When, for instance, the watch is on cold winter nights taken out of the warm pocket and exposed to the cold air of the sleeping apartment, the humidity of the warm air within the watch will be condensed and precipitate in microscopic globules on the parts of the movement. The exhalation of the body contains a certain percentage of acids, which, of course, are contained within the aqueous precipitations, and in this manner the generation of rust and verdigris can easily be explained.

Many a watchmaker has doubtless tried in vain to remove these disagreeable spots, without injuring the spotting on the nickel plates, bridges, etc. The *Journal Suisse d'Horlogerie* recommends a method by which it says this can be effected without injuring the spotting while at the same time restoring all the brightness and freshness. Mix 50 parts of rectified alcohol and one part sulphuric acid, immerse in this fluid for about from 10 to 15 seconds the parts to be refreshed. As these parts must be exposed in it only for a short time, it is well to take only a few at a time; after withdrawal, rinse them thoroughly in clean water, and then enter them for a short time in rectified alcohol. Dry either with clean soft linen or in sawdust. Movements brightened in this manner will be as handsome as when new, while their spotting is in no manner injured, which will invariably be the case when using the buff-stick and chalk brushes.



[FROM OUR SPECIAL CORRESPONDENT.]

PHILADELPHIA, Sept. 20, 1889.

Trade in the "Quaker City" is improving rapidly. Because the severe storms of the past few weeks, visitors at the seaside resorts have been straggling in as soon as railroad communication was opened up, and this always means a revival of business in the jewelry line, however inclement the weather. The clear skies of the last few days, however, have given a fresh impetus to business, and most of the large retail houses are quite busy. The jobbing trade is also greatly improved. Travelers are sending in plentiful orders, and all have settled down to work in earnest. The only drawback is that collections are rather slow, but Philadelphia is not remarkable in this particular.

James E. Caldwell & Co. have been refitting their art rooms upstairs, putting up costly partitions and carpeting the rooms with a handsome inlaid wood carpet in the most modern style. This improvement will give them ample facilities for the display of the large lines of hall clocks, bronzes and art goods which they carry, in the choicest varieties.

We are pleased to announce the prospects for a large attendance at the new American Horological Institute of 1723 Chestnut street, this city, as being all its founders could have hoped. The promised success of this institution is certainly no more than its founders deserved, as among its corps of instructors are as good horological talent as the country affords, and the methods and tools will be such as to afford the pupil every advantage. In looking over their system of instruction and the appliances to aid in imparting the art, it does seem as if heretofore a great part of the time a learner spends in acquiring the trade of watchmaker or jeweler had been misspent. What the trade has been wanting for years past is just such institutions for the thorough training of workmen who wish to become proficient or those who may choose the trade from having a natural liking for it. Remember the address is 1723 Chestnut street, Philadelphia.

David F. Conover & Co. have now ready for distribution their new material and spectacle catalogue for 1890. It is a handsome folio of nearly 400 pages, copiously illustrated and neatly bound. The trade are urgently requested to send in their cards and get a copy of this catalogue, which will be sent only to the legitimate jewelry trade.

Henry Troemner, the manufacturer of jewelers' scales and weights, returned last week, after a sojourn of several months in Europe. He did the Continent quite thoroughly, and was much improved by the furlough.

B. J. Cooke's Sons, the well known clock dealers, are very busy, and hope to be kept so for the balance of the year. They announce that they never were so well prepared for business as now, never before had so large a stock or so great a variety of clocks and bronzes. Onyx and marble c'locks, they find, are having an unusually large sale for so early in the season. Mr. Ben Cooke has been on the road for the last three weeks, and is meeting with great success. This house has what the people want, a selection of the best goods of all the manufacturers, brought together and sold at factory prices.

M. Zineman & Bro., 130 South Ninth street, Philadelphia, manufacturers of the "Diamanta" spectacles and eyeglasses, have christened themselves "The Busy Opticians," and the name is no misnomer, for their business growth has been something phenomenal. Almost from the start they have been improving their facilities, till now these are adequate to all demands.

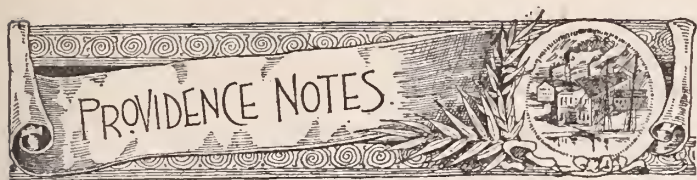

[FROM OUR SPECIAL CORRESPONDENT.]

PROVIDENCE, R. I., Sept. 15, 1889.

The improvement in business during the past month with the manufacturers has been slight, and there has been general complaint on all sides, but now that the Treasury Department has unlocked some of the money in its coffers, is it not reasonable to suppose that some of it will find its way back again through the regular business channel of the country? The high rates charged for money during the past month has, no doubt, had a bad effect on the business interests of the country, and is reflected in the dulness of the jewelry branch of the trade, and the seeming reluctance with which jobbers for the past month or six weeks have settled accounts long since due. Collections have been almost impossible to make, and trade paper is becoming more plentiful, for from one to six months.

Edward Holbrook, of the Gorham Manufacturing Co., was in the city during the past week on business connected with the affairs of the company.

With the following list I am pleased to note some of the heavy taxpayers, notably manufacturing jewelers and the kindred branches, with the amounts of each individual or corporation, viz.: Kent & Stanley, \$76,560.00; S. B. Champlin, \$81,180.00; Gorham Manufacturing Co., \$307,140.00; John C. Knowles, \$119,600.00; George Owen, \$221,580.00; Smith Owen Estate, \$259,060.00; Gorham Thurber Estate, \$197,280.00; Dutee Wilcox, \$194,980.00; Nicholson File Co., \$199,960.00; A. B. Gardiner and wife, \$78,580.00; M. Fitzgerald, \$84,960.00; John Austin, \$150,940.00; Brown & Sharpe Manufacturing Co., \$92,080.00; John M. Buffinton and wife, \$63,120.00; Thomas Davis, \$118,480.00; Stearns Hutchins and wife, \$50,100; George W. Ladd and wife, \$72,540.00; S. G. Martin, \$58,760.00; C. H. Perkins and wife \$232,680.00; I. M. Potter, \$70,160.00 and D. B. Waite, \$56,200.00.

F. T. Pearce & Co., have bought the property, rights, etc., of the late Chas. W. Livermore, known as the Stylographic Co., and will add this branch to their large and increasing business.

Barstow & Williams are now making a fine line of manicure goods, in addition to their line of match and stamp boxes.

Henry G. Thresher, of Waite, Thresher & Co., has lost his only son Chester Fanning, who died at Central Falls on Friday.

H. M. Howe, B. L. Hall and George Willis were among the delegates who attended the Grand Army Encampment at Milwaukee last week.

John M. Fisher, one of the committee chosen by the Jeweler's Board of Trade, representing Providence and Attleboro, to go to Kansas City, and investigate the failure of Pond, Wilmes & Co., in which many Eastern manufacturers lost money, was called before the counsels representing the bankrupt firm as well as the creditors in the association rooms in this city, Tuesday afternoon. Mr. Fisher made a thorough examination of affairs, and for four hours stood well under the fire of the lawyers on both sides. New discoveries concerning the failure have been made which are withheld until some future time.

Nelson S. Davis, of the firm of Davis & Emerson, who is Captain of the Narragansett Boat Club, was elected alternate judge at the annual meeting of the National Association of Amateur Oarsmen, held at Pullman, Ill., on the 8th, 9th and 10th insts.

Charles H. Downs was appointed trustee of the estate of the late Charles Downs, by Judges Matteson and Tillinghast, on the 7th inst., in the place of J. B. Mathewson, deceased.

The Pomham Club, on Tuesday last, gave one of their swell din-

ners, to about 200 members and guests. This club is largely composed of the manufacturing jewelry firms in this city.

B. M. Jackson, treasurer of the Narragansett Card Co., who has been passing part of the summer in Vermont, has returned home.

The New England Jewelers' Association held a meeting on the 15th ultimo. at "Tillinghasts," and decided by a unanimous vote to continue the association. The meeting was presided over by Pres. Lowe. J. M. Buffinton, Chairman of the Executive Committee reported favorably upon the following applications for membership viz: T. G. Frothingham, of North Attleboro, E. B. Thornton, Chas. Downs and Levi L. Burdon, of Providence, and they were declared elected. The following well-known persons, members, were noticed at the banquet: President Edwin Lowe, Vice-presidents W. W. Fisher and O. C. Devereux, Secretary John A. McCloy, Treasurer H. F. Carpenter; Executive Committee, J. M. Buffinton, F. T. Pearce, and H. G. Smith of Providence, Major E. S. Horton, of Attleboro, John Smith, C. F. Dennison, P. T. Parsons, B. A. Ballou, J. H. Fanning and Walter I. Gardner, of Providence.

L. R. Horton has assigned his patent on designs for spoon handles to Mess. J. B. & S. M. Knowles.

The court has allowed the executrix of the estate of Giles Manchester, to sell at private sale, the interest of the deceased in the late copartnership of Messrs. Fessenden & Co.

The following named jewelers contributed to the fund for the poor childrens' excursion down the bay; Isaac M. Potter, Isaac L. Goff, Joshua Gray, Barstow & Williams, Tilden Thurber & Co. and Wood, Bicknell & Potter.

Several R. I., G. A. R. members attended the re-union of the New Hampshire Veterans, last week. Among the members were noticed Col. Isaac M. Potter; Ass't Postmaster Col. Chas. H. Williams, of Providence, and Major E. S. Horton, of Attleboro.

C. B. Smith formerly with Messrs. Mackinney, Smith & Co., now represents the enterprising firm of Messrs. Kent & Stanley as manager of their New York office, at No. 17 Maiden Lane.

W. H. Luther entertained a party of friends from Newburyport, Mass. at the Pomham Club last week.

Grand representative W. R. Dutemple left on the 14th inst. for the West, for Columbus, Ohio, to attend the meeting of the Sovereign Grand Lodge of Odd Fellows.

Col. Moore of the Dueber Watch Case Co., was noticed at the Narragansett Hotel, the other evening, and was in his usual good spirits.

Flint, Blood & Co. have just issued a book of ring designs, which embraces many new and unique styles.

Mr. A. Aidrich late manager for Messrs. Tilden, Thurber & Co., has accepted a position with the Miller Chemical Fire Extinguisher.

Mr. Frank W. Taylor was elected Great Sachem of the Grand Lodge of Red Men on Thursday.

Mr. Ernest Zahm of Lancaster, Pa., has been in the city for a few days, and left for Newport on Wednesday night.

Mr. B. Auerbach of Montreal, has been in the city buying goods for the Fall and Winter trade.

Mr. Hiram Howard has declined to be the Democratic candidate for Mayor at the coming election. Mr. Howard feels deeply the high honor which the party would bestow upon him as their standard bearer but, at the same time thinks that it would not be advisable to accept of the nomination. Being of a go-ahead disposition, he would be hampered by the inactivity and sluggishness which seems to pervade all improvements now under way or in contemplation by the city viz: terminal facilities, sewers etc., which would not be in accord with his ideas of progressiveness for a city of the size of Providence.

Ostby & Barton have been obliged by their fast growing business to take another floor in addition to that previously occupied. They have fitted their new quarters with great taste in ash and walnut trimmings and have their entire quarters lighted up by electricity. This is one of the most progressive houses in the business. They are constantly adding to their stock of fancy rings until their line at

present is unrivalled for variety and novelty. As to their band ring patterns, their name is legion.

The New England Manufacturing Jewelers Association held their annual "Field Day" on Saturday at Lake Pearl near Wrentham Mass. Providence members will take the 9.30 A.M. train for North Attleboro where they will take the barges for the lake. Dinner will be served at 12.30.

Kallmeyer Bros. of Detroit are reported here as having left their business and gone to Canada, after placing chattel mortgages to the amount of \$12,000,00. Eastern creditors are in for about \$30,000,00 amongst the number being Kahn & Co., H. Muhr's Sons, Howard & Son, Fowler Bros., Horton, Angell & Co., E. A. Potter & Co., and others.

FAIRFAX.



[FROM OUR SPECIAL CORRESPONDENT.]

AFTERMATH ON THE BIG GRAIN FIELDS.—STRAWS WHICH SHOW THE WIND.

MINNEAPOLIS, Minn., Sept. 12, 1889.

Trade in the twin cities and their neighboring towns has been comparatively dull for the last two or three months on all lines, and the jewelry business has been no exception to the rule. Even when it was first hoped and then promised that the wheat crop, upon which this region so largely depends, was to be not only an average one, but above the average, people were cautious and doubtful, as first indications had been so discouraging. Many here regarded increasingly favorable reports as to the probable harvest as political trade fakes, and meant to be quite sure they were right before they went ahead. But now that the crops are actually harvested, threshed and being stored, the Thomases are catching on to the band wagon, and everything points to a lively Fall and holiday trade. All jewelers report an increased activity already.

The Minneapolis Exposition, which opened August 21, and will close the 28th of this month, and the state fair at Hamline, midway between the cities, annually draw large out-of-city crowds. The jewelry trade is one of the last to feel the impetus of their sojourn, however, though dealers report a small increased trade, and some jewelers from other towns are looking up stock. The movement is felt principally by retailers who dispose of much to the country trade at this time, which makes room for holiday stock.

Warner & Co., wholesalers, for instance, say that the Exposition time makes little difference to them usually, though this Fall they have supplied retailers with considerable light stock. They grumble, as others do, that collections are hard. Money, though loosening, as crops are disposed of and milling begins, is, so to speak, only preparing to pucker. This, perhaps, is the reason the diamond trade this Fall has not been quite so good as it was last year at the same time.

There seems to be considerable feeling in Minneapolis with regard to wholesalers selling to department stores and to retailers who sell on the installment plan. Some time ago a state association was formed to discourage it. A. C. Clausen, its secretary, made a voluntary assignment, August 17th, to Louis D. De Mars, of the De Mars Manufacturing Jewelry Company. His assets are placed at \$3,000, liabilities, \$4,800. Mr. Carpenter of the Minneapolis Jewelry Manufacturing Company, is one of those who assert he will not be dictated to by the trade and he will sell where he pleases.

A new diamond firm has been formed in Minneapolis: Allen & Co., with fine offices in the new Bank of Commerce building.

The Retail Jewelers' Association, of St. Paul, to the number of 75, took in the state fair this week, piloted by one of them, F. M. Finch, who has had charge of the main building and has distinguished himself as usual. The visit was a compliment to him.

J. S. Bredenbeck, of Minneapolis, has removed to West Duluth, to go into business.

W. W. Houghton, of Fargo, is in Minneapolis on business. He has jewelry stores in Fargo, Dakota and Little Washington.

What truer than the adage, "Delays are dangerous!" Arnold Monsette, a jeweler of this city, died recently. He was a member of the Knights of Aurora, and had insured his life for \$1,000. He had passed his examination, the policy was made out and in the hands of the secretary waiting for Monsette to call for it. There was fifty-five cents advance payment due on the policy and twenty-five cents reserve fund fee. Monsette neglected to call for the policy or to pay the eighty cents. He died suddenly and his family lost the \$1,000. The officers of the order would have paid the amount if they could, but would have had to perjure themselves by swearing that all dues were paid up.

Francis Talcott, the veteran jeweler in St. Cloud, Minn., has sold out his stock. He has surely earned a rest, having been in the business for over fifty-three years. He was a pioneer, too, having gone to St. Cloud from Glastonbury, Conn., in 1856. Ahmann, Ladner and Sommel, of Richmond, and Edelbeck Brothers, of Melrose are purchasers.

Speaking of Melrose, the people there are much perplexed over the sudden disappearance of a jeweler named William Swain, with about twenty watches, several clocks and a shot gun. A short time ago he opened a watch and clock repairing shop there and had worked up a good business. No trace of him or his property can be found. The St. Cloud police have been notified.

Matrimony is striking the jewelers. Owen Jones, one of the successful business men of Tower, Dakota, was recently married to Miss Fanny Sawbridge. They have gone east for their wedding trip. Mr. Jones will buy his Fall stock in Chicago before returning.

Another jeweler, F. C. Taylor, of Hastings, was married to Miss Maud E. Morse, this week.

Gustav Miessle, of Springfield, Minn., was unfortunate last week in having five watches stolen from his store by burglars who cut away the screen and a large pane of glass.

George Beamer, of Lead City, Dakota, has established a jewelry manufacturing establishment there, for working up the gold of the Black Hills, and has a large and unique stock.

STATE CONVENTION OF THE MINNESOTA RETAIL JEWELERS' PROTECTIVE ASSOCIATION.

The Minnesota Retail Jewelers' Protective Association held an interesting state convention in St. Paul, Wednesday, Sept. 11th. T. B. Myers, President and P. Egan, Treasurer, of St. Paul, and A. C. Clausen, Secretary, of Minneapolis, were present as were also a number of retailers from various places in the state. The meeting was the first general one since the organization of the association, two months ago, as outlined in this correspondence to the CIRCULAR. Advantage was taken of the fact that a large number of retailers were in the city to get the members of the association together to advance the mark which was undertaken at the time the organization was effected. Among the resolutions adopted was that a recommendation be made to all members of the association to refuse to buy from manufacturers and wholesalers who sold through traveling men or otherwise than through the regular retail stores, to retail purchasers. The selling to dry goods stores, department houses, dealers on the installment plan, who were not regularly in the jewelry business, and the selling through traveling men direct from the manufacturers to hotels, restaurants, etc., was discussed and censured. A position was taken against the catalogue system, on the ground that many besides those in the trade see them and consumers write for the prices direct, and so manufacturers fill orders which would ordi-

narily fall to the retailers. Action was taken on a number of matters in connection with the extending of the membership of the association and a number of new members were admitted. A. C. Clausen on account of his failure and retirement from the business, resigned the secretaryship, but his services were too valuable to dispense with and his resignation was not accepted. The president, T. B. Myers, expects great things from this association and is contemplating a trip through the state to visit the retailers, arouse interest in the association and increase its membership.

The following resolutions were read and unanimously adopted :

Resolved.—That the indiscriminate circulation of Jobbers' catalogues is condemned by the Minnesota Retail Jewelers Protective Association, as being prejudicial and injurious to the business of the Retail Jeweler, and that it is the desire of this organization based upon the individual experience of its members, that they be withdrawn.

Resolved.—That the privilege of Manufacturers and Jobbers to sell at retail, even under price restriction, is construed by the Association as an unjust discrimination against the retailer; for any reasonable restriction if enforced, is prohibitory in itself, and the jobber can only successfully retail at a price, less than will afford the retailer a profit.

Resolved.—That a refusal by the manufacturer to rebate to the retailer, when rebates are made to the jobber; in the event of a reduction in prices, is regarded by this Association with disfavor. And it is recommended that the goods of any Manufacturer so offending, be discarded by members of this Association.

Resolved.—That the Executive Committee be instructed to confer with the Associations of other States, and the Jobbers' Association in American Watches, and the Manufacturers and Jobbers not in the Association, for the purpose of securing to the Retailer, an impartial adjustment of his equity in his relation with the Manufacturers and Jobbers.

Resolved.—That a copy of these resolutions be forwarded to the various journals of the trade for publication.

HENDERSON.



[FROM OUR SPECIAL CORRESPONDENT.]

PROSPECTS AT THE "HUB."—INTERVIEWS WITH THE TRADE—A BUDGET OF SMALL TALK.

BOSTON, September 16, 1889.

The dead center of commercial inactivity has been overcome. The fall boom has begun and the jewelry trade shares in the general anticipation of prosperity. This condition of affairs is peculiarly gratifying, because in a measure unexpected. The disturbances of the early summer shook the business fabric of New England to its very foundation, and on all sides a financial crisis was predicted. The heavy leather failures of May and June were followed inside of a month by crashes in the woolen market that involved an ever-widening circle of disaster, from which the banks and other money centers are only just beginning to recover. That they are doing so at all is positive proof of the inherent soundness of affairs; and it is now generally conceded that the individual catastrophes that have occurred have served in the beneficent capacity of a public warning—a warning that has been heeded by conservative tradesmen.

Ripley, Howland & Co. see in this a season full of promise, and voice the sentiment of the jewelry trade at large in stating that local trade is to-day ahead of last year's record for the same time. Everyone points with confidence to the solidity of the iron market, the steady increase of railroad transportation and the prosperous crop reports are sure exponents of vigorous commercial activity from this time on. This means, of course, plenty of money, and an increased liberality in the popular taste and demand. The fall orders that have already been sent in by suburban retailers show that this phase of the situation is clearly realized.

Floyd, Pratt & Rounds join in the chorus of hopeful expectation. "It is one of the best signs possible," said Mr. Pratt, "that the activity is general rather than in special lines. There aren't more than half a dozen novelties in the list. I have my statement on sales already made by our house and by others. That shows that the only thing that has had a "boom" is bead ware. The demand for bead necklaces and bracelets is everywhere ahead of us. This is the more remarkable when it is recalled that a year or two ago the trade tried to push these goods to a moderate extent, but met with little or no encouragement from the public. Perhaps, on the whole, the most remarkable feature of this sudden revolution in taste is the spontaneity of demand. It is the result of work by no particular house, yet people are calling for beads with a rush that threatens to embarrass us wholesalers."

I want to stop long enough right here to tell a little story that will be appreciated by all who are acquainted with the qualities of jeweler Pratt as a sportsman: It seems that on a recent gunning trip through the woods of Maine, his party sighted a single partridge in the road, its head alone just peering out of the brush at one side. The honor of shooting it was accorded to Pratt, who failed, however, much to his own surprise and the general merriment, to even ruffle a feather. The bird flew off into the thicket with a mocking whirr and began to "drum" in lusty self-congratulation, while the unfortunate marksman remarked with casual indifference: "I want you all to understand that I'm a wholesaler from Boston, and I don't do things on a small scale." As luck would have it, three birds were discovered nestling in the wheel ruts a few rods farther on. This time the Pratt broadside killed all of them at a single shot. "I want you all to understand," remarked the now vindicated sportsman with grim satisfaction, "that I'm a wholesaler from Boston, and I don't do things on a small scale."

James W. Tufts reports plenty of early orders, and looks for a steady boom up to January 1. I am given to understand that this firm's silver department is developing remarkably. There are fifty men now on the road, and they are sending in the best of reports from every section of the country. Tufts makes a specialty of ware finished in old silver and rich in raised relief. This branch of the business was started in 1877, and since 1881 it has been a great and growing department. There are those who easily remember the old days when the manufacture of soda apparatus kept the concern busy only three months in the year. A large part of that work required skilled labor, and it was early discovered that most of the men were capable of being put directly into the various branches of making assorted silverware. Nowadays the change from one class of work to another is made easily, and the workmen find steady employment. Indeed, with the total force of 700 there are not over 50 changes in the year. The Tufts people have, among other things, undertaken to revolutionize the public taste in silverware. It isn't so very long ago since the oxidized variety was in principal demand, and it was not until a new finish was introduced by another and more expensive process that the fashion changed. Mr. Tufts claims that the new product is far superior to the oxidation artistically, and more profitable practically. "Besides," said he, "we find that our old-silver finish is much better adapted to set off varied relief than the older style." James W. Tufts, by the way, has removed his New York warerooms to more commodious quarters at No. 10 Warren street, near Broadway and City Hall. Removals have been frequent with the house, but there is significance in the fact that each time larger quarters have been taken. The new Tufts catalogue of fall styles is now in the hands of the printer.

The general atmosphere of prosperity pervades the retail trade as well. Several establishments report increased sales in diamonds, more especially in ring form. This is largely accounted for by a growing use among the middle classes of society, and the fact that the demand is steady encourages a belief in the popular character of the "good times coming."

"The fact is, as far as we are concerned," said W. B. Foster, of

Foster & Emerson, that we can easily convince a lady that an emerald is superior to a diamond; that a person who buys a first-class emerald gets a rarer thing than one who has a diamond of the first water—and our wealthy customers are beginning to see it.

One of the handsomest and most unique retail establishments in the country has just been opened by the Alexander Company, at 26 West street. The officers are: President, James E. Alexander; Vice-President, E. G. A. Isenbeck; Treasurer, Edw. K. Barnes. The concern is to do a jewelry and silversmith business. Messrs. Alexander and Isenbeck have been with Shreve, Crump & Low for several years, while Mr. Barnes has been with Chas. W. Kennard, and more lately with Rand & Crane. The new store is a model. It is fitted throughout in the old colonial style, and the brilliancy of its stock display is dazzlingly effective. A Lincrusta-Walton dado, eight feet high, in ivory finish, is surmounted by a frieze in cream and orange tints, with festoons in white. The familiar Grecian pattern adorns the ceiling in light shades. The furniture is of solid cherry, while the show cases are a good four inches deeper than those in ordinary use. The Alexander Company will sell nothing but solid ware, with watches and diamonds. The store is located just on the border of the exclusive Back Bay district. All its managers are young and popular men with wide business experience.

Watchmaker S. S. Crosby and H. Towne have apartments in the same store.

I have sought to obtain the opinions of leading tradesmen on the subject of the World's Fair and the best policy of the jewelry trade regarding it. But little interest is taken in the matter here. It is urged that to many houses the fair would be of comparatively small practical benefit. As a leading retailer said to-day: "If a big dry goods house offers special attractions, people will flock in and buy. But you can't expect them to buy half a dozen watches or a dozen rings because they happen to be offered at special rates or are extensively advertized." Be this view of the matter right or wrong, the fact remains that the local trade has made no movement in the matter of the fair as yet.

There are eight firms now in the newly-organized Boston Credit Jewelers' Association. According to Secretary W. B. Foster, these eight represent about seven-eighths of the trade of that class. The organization has been running so short a time that the proposed exchange has not yet been established. The list is nearly complete, however, and the members expect that the venture will be well worth the work of organizing it.

Among the installment canvassers employed by Wm. S. Crown, the well-known jeweler, at 186 Washington street, was Urbine Martin, of East Boston. This agent took a number of watches, valued at \$441, but failed to satisfactorily account for the same. The police arrested him for embezzlement.

Right in this criminal connection comes the case of Jeweler C. G. Show, of 71 Warren street, Roxbury. He has been ill of late and left his business in charge of clerk Frederick J. Marsh. Last Friday it was discovered that Marsh and another clerk named William Prout had conspired with one Geo. Steele to rob the place of \$1500 worth of goods. Prout had them all packed in a trunk ready to leave the city, when the arrest was made.

President [Chas. H. Harwood, of the Boston Jewelers' Club has returned with his daughter from Europe.

It is reported that Louis A. North, a former representative of Jas. W. Tufts & Co., has forged a \$1000 draft on that firm. He was discharged in July and has been carrying on his criminality it is said in Texas, ever since. He is thirty years old, belongs in Macon, Ga., and has not yet been arrested.

The Frederick J. Marsh, of whom I spoke in connection with the Shaw case was, I learn, formerly in business for himself in Hartford. He failed and owed Whitney Bros., of this city, heavily.

Our police have been consulting with Inspector Byrnes, of New York regarding the W. B. Morse robbery, but nothing definite has yet come of it.

The Acme Silver Plating Company are apparently on the high road to prosperity. They have just leased a new building at Boylston Station for ten years and will occupy three entire floors.

President Cavins, of the Credit Jewelers' Association, spent a week's vacation at Kearsarge, N. H.

The fifth "merchants' week" has boomed the local trade.

The wife of W. H. Kennard, of Bigelow, Kennard & Co., died recently at the family residence on Newbury st. Mr. Kennard has the sympathy of the entire trade in his affliction. LEON.

The Jewelers' and Tradesmen's Company.

GILBERT T. WOGLOM, *President*.

THOMAS A. YOUNG, *1st Vice-Pres.*
SHUBAEL COTTLE, *2d Vice-Pres.*

EPHRAIM S. JOHNSON, JR., *Sec'y.*
SAMUEL W. SAXTON, *Treasurer.*

BOARD OF DIRECTORS.

JAMES A. SMITH, M. B. Bryant & Co.
EPHRAIM S. JOHNSON, Treasurer, E. S. Johnson & Co.
SAMUEL W. SAXTON, President Solid Link Chain Mfg. Co.
CHARLES A. FOWLER, Fowler Bros.
JOHN C. DOWNING, Downing, Keller & Co.
SHUBAEL COTTLE, President S. Cottle Company.
THOMAS A. YOUNG, Ex-President National Association of Commercial Travelers ;
Chairman Legislative Committee and Vice-President of the Commercial Travelers'
Asso'n, State of N. Y. ; President Traders' and Travelers' Union.
CHARLES F. ROBERTS, M. D., *Medical Director*, 69 E. 54th St., N. Y. City.
SAMUEL A. BALDWIN, W. E. White & Co.
GILBERT T. WOGLOM, Gilbert T. Woglom.
WILLIAM B. KERR, Kerr & Battin.
SAMUEL SONDEHEIM, Bruhl Bros. & Co.
Counsel, JAMES M. HUNT, (of Rudd & Hunt) 31 & 33 Pine Street.

The continued energy of the management in presenting the merits of this association is being rewarded, even during the recent "outing" season, by a steady accession of new members, as follows:

Abram Bachrach, S. Bachrach & Sons; George Harges, M. J. Rooney & Co.; Gustave M. Lippmann, Pforzheimer, Keller & Co.; Rudolph Beyers, Philipp Silbermann, Alexander Walker, J. Howard West, I. Shelby Weiler, Vernon O. Ricker, John M. Peters, Wm. M. Morgan, all of New York City; and Paul P. Fleeth, P. P. Fleeth & Co., La Grange, Ga.; Titus Pantillon, A. B. & J. S. Holmes, Jr., Newark, N. J.; Ernest A. Spierling, Stamford, Conn.

The membership is now distributed over 28 States of the Union.

The Jewelers' Security Alliance

President, DAVID C. DODD, JR.

First Vice-President, AUGUSTUS K. SLOAN, Of Carter, Sloan & Co.

Second Vice-President, HENRY HAYES, Of Brooklyn Watch Case Co.

Third Vice-President, DAVID UNTERMEYER, Of Keller & Untermeyer.

Treasurer, CHAS. G. LEWIS, Of Randel, Baremore & Billings.

Secretary, GEO. H. HODENPYL, Of Hodenpyl & Sons.

EXECUTIVE COMMITTEE.

J. B. BOWDEN, *Chairman*, Of J. B. Bowden & Co.

C. G. ALFORD, Of C. G. Alford & Co.

N. H. WHITE, Of N. H. White.

F. KROEBER, Of F. Kroeber Clock Co.

SILAS STUART, Of Silas Stuart.

H. H. BUTTS, Of H. W. Wheeler & Co.

EXAMINING FINANCE COMMITTEE.

J. P. SNOW, Of G. & S. Owen & Co.

HENRY ABBOTT, Of Henry Abbott.

For further information, Application Blanks for Membership, By-Laws, etc., Address
P. O. Box 3277. 170 Broadway, New York.

The regular monthly meeting of the Executive Committee was held at the Alliance Office, on the 3d inst. There were present J. B. Bowden, Chairman, Messrs. Lewis, White, Butts, Stuart and Geo. H. Hodenpyl.

The following were admitted: A. M. Mossman, Woods Square, Hudson, Mass.; Emil Ader, 266 W. 125th St., N. Y. City; C. F. Lauterback, Petersburg, Va.; C. H. Daniels, Malden, Mass.; Jacob Karr, 945 Pennsylvania Ave., Washington, D. C.; H. W. Seaman, Washington, Pa.; Adam C. Miller, 107 Broadway, Brooklyn, N. Y. Robert Ernst, 103 Washington St., Vicksburg, Miss.

PARIS GOSSIP.

[FROM OUR SPECIAL CORRESPONDENT.]

SPAULDING & CO.'S NEW STORE.—TWISTED IVORY BEING IMITATED IN SILVERWARE MANUFACTURE.—SHALL THE ANCIENT JEWELLED SILVERWARE BE REVIVED?—THE EFFECT OF THE EXPOSITION UPON THE AUTUMN TRADE—THE EIFFEL TOWER IN DIAMONDS.

PARIS, September 10, 1889.

SPAULDING & COMPANY.

Spaulding & Company, of Chicago, have hardly opened their new Paris establishment more than a few weeks, at 36, Avenue de l'Opera, and they seem already as well known by the *Paris élégant* as though they had been here for years. It is impossible to find anywhere a jewelry establishment more attractive. The show rooms are directly beneath the American Consulate, in the Avenue de l'Opera, and are handsomely fitted up in white and gold. A reading room offers to visitors a complete set of papers from all parts of America; there is also a small post box for the convenience of customers who desire letters addressed in care of the firm. A most interesting feature is the "Evening Room," lighted with a 200-candle power electric light and draped with black velvet hangings. Mirrors are placed above and on all sides, so that a person standing in the center of the room can realize the effect of the jewels in a ball room or at the opera. The Shah of Persia, during his stay in Paris, visited Spaulding & Co.'s place, and purchased a lovely diamond brooch, showing a flight of five swallows. In one of the rooms is a beautiful Louis Quatorze cabinet made of citron wood with metal ornaments handsomely chased, the key, in steel, being most daintily wrought. Baron G. de Rothschild offered a high price for it, and would certainly have valued this fine piece of furniture as one of his choicest curiosities. On entering the stately show room, visitors are at once fascinated by the great variety of jewels resplendent in their pretty glass cases set in pale blue, pink and white leather, and by the remarkable display of the Gorham Co.'s silver wares, whose original styles and perfect finish have so thoroughly conquered the visitors at the Exposition. Spaulding & Co seem to understand what must be done to attract to their store not only the American Colony in Paris, but also the high society in France. Their glass cases contain so many different specimens of the jeweler's art that it is impossible for persons of good taste not to find something to their liking there. As to the silver articles, they all bear the mark of the greatest silverware manufactory in the world, a name now familiar to Parisians of all classes. Mr. H. A. Spaulding will leave for America by the French Line on September 28th to take charge of the business of the Chicago house.

JEWELLED SILVERWARE.

Why should we not adorn our silverware with jewels? M. Germain Bapst, who delivered on the 27th of August a lecture on Merovingian jewelry and Orfeverie at the Focadero Palace, remarked passingly that a revival of that style might prove a success. I am afraid it would have to be greatly altered in order to take with the general run of customers. As to the upper classes, I think they would only appreciate genuine old pieces of that kind, or those at least supposed to be real. It is evident that a refined jeweler, as M. Bapst is, would need to put away for a moment his delicate taste and become purely an archæologist, to admire the workmanship of those barbarian relics. Yet the fashion might be revived, to some extent, by intelligent jewelers and silversmiths if they would select from among the numerous fibulæ those which could be best adapted to our modern ideas. With a less clumsy setting than the ancient one and a better arrangement of the garnets and similar stones, they might possibly manage to make it popular. I believe that in gold and

silversmithing very elegant pieces might be obtained with a Merovingian revival. But if filagree work were to be used in preference to the massive style it would be easy for the public to confound it with an Oriental style. After all, if we are to credit our lecturer, that special art was imported from Asia into Europe by a race of men who invaded our continent about eighteen hundred years ago and spread gradually all over it, taking nearly 400 years to come from Samarkand to the Gallic territories. This is corroborated by the discovery of articles of jewelry, similar to what we call the Merovingian style, in Russia and other parts of Europe widely distant from each other.

A NEW DESIGN IN SILVERWARE.

Parisian silversmiths have applied themselves lately to making all kinds of articles in imitation of twisted ivory. Some show conventional leaves of a mediæval style, shooting about so as to form the

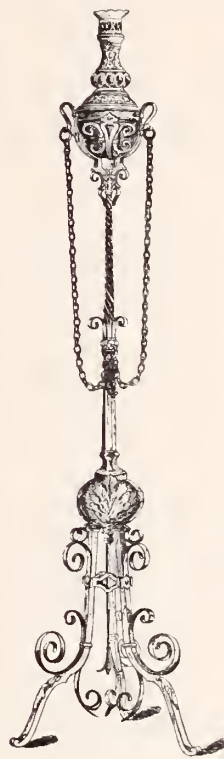

base of a candlestick or of a flower stand. Some handle that new fashion in a sober manner, simply curling the metal in a symmetrical way, and aiming at the production of an article light and graceful in appearance although made of massive silver. Though applied to such articles as lamp stands, etc., the same inspiration is noticeable among flat wares, and several patterns of spoons and forks have handles in open work, showing a pretty imitation of renaissance keys. Of course, everything is calculated so as to avoid as far as possible the unpleasantness of sharp edges coming into contact with delicate fingers. These patterns generally consist of conventional foliage or elaborate ornaments; introducing a bird, an insect or a chimera. This style seems to have reigned in jewelry for a long time before it found its way to the silver manufactories, and I have frequently mentioned hair comb heads, brooches, bracelets, chatelaines, and even studs, made according to this fashion, with the association of enamel work or the addition of precious stones.

DEALERS FLOCKING IN.

Provincial retailers are beginning to visit the manufacturing centers. Their notions being greatly altered by what they see at the Exposition, they seem, generally speaking, very difficult to please. Some retailers belonging to small towns, who have been hitherto accustomed to buying plain goods, are going in for more refined articles. They are naturally afraid that the people they serve, after having paid a visit to Paris and seen all the novelties, might, on their return home, look with a kind of contempt on their stock. This fear may induce them to buy more goods of fine quality.

Business is, no doubt, very brisk at present, but it is impossible to foresee whether it will remain so for long. The extraordinary animation now reigning in Paris is bound to benefit most trades for a time. Let us hope it may be maintained after the now prevailing excitement has subsided.

THE EIFFEL TOWER IN DIAMONDS.

I have just seen at the Galerie Petit, the Eiffel Tower made of diamonds. It is one metre high, and consists of 1,350 pieces which can all be unscrewed. 3,000 pearls represent the gas lamps, which on the real tower are lighted up at night. The imitation is carried as far as possible. You see the lights, the stairs, the restaurants, the revolving lighthouse (made of rubies). 13,500 hours were spent over this work. Besides the enormous quantity of diamonds, there are no end of pieces in chased and enameled gold, and the whole of it rests on a porphyro stand weighing 170 kilogrammes. This wonderful piece of jewelry is worth \$600,000 (three million francs). JASEUR.

Fashions in Jewelry

A Lady's Rambles Among the Jewelers and Dealers in Art Glass and Keramics.

THE WIDE latitude allowed in the selection of jewelry and silverware, is a noticeable feature of the present season. Round brooches are on the top wave of popularity, and yet some of our largest manufacturers are still making bar pins. Chased silver was never in greater demand, but every progressive silversmith keeps in his stock silver of bright finish, oxidized silver, and silver decorated with pierced work.

* * * * *

THE QUEEN and its offspring, the Victoria chain, represent the most fashionable watch chains now in the market, for ladies' wear.

* * * * *

ONE OF the most popular articles known to the jewelers' trade at the present moment, is the collar button. The one-piece, seamless, solderless, hollow stud, about which so much has been heard of late, appears to be a very desirable button. This one-piece affair is also represented in shirt studs for men, and chemisette studs for women.

* * * * *

COLLAR BUTTONS come in a variety of styles. There are some with plain surface, chased tops, and others set with a diamond or other gem. Collar buttons set with turquoise are much sought after by ladies who do not wish the expense of a diamond mounted button.

* * * * *

THE SHOW CASES demonstrate the fact that enameled jewelry has come to stay. It is out in new and pleasing fashions in which floral models appear to take the lead.

* * * * *

ENAMEL brooches and scarf pins are produced which imitate to perfection the size, shape and color of nature's blooms. Nothing is wanting but the fragrance.

* * * * *

A QUESTION which no one seems able to answer is, "Which is the more popular, the flower pin representing a single large flower, or the one that simulates a cluster of small blossoms?"

* * * * *

THE WOOD violet is a favorite flower in jewelry. Wood violet brooches that represent a bunch of violets so arranged as to form a nearly round pin, come in three sizes, small, medium and large.

* * * * *

A NEW use has been found for the miniature paintings which heretofore have been mounted chiefly for brooches. These are now placed in silver belt buckles and chatelaines, making exceedingly effective ornaments.

* * * * *

THE VARIETY of styles in which belt buckles have been produced

for the autumn trade, is sufficient evidence of the great popularity of these articles.

* * * * *

SILVER belt buckles are worn not only on silver and leather belts but on ribbon ones as well.

* * * * *

MANY of the patterns seen in brooches are reproduced greatly enlarged in belt buckles and chatelaines.

* * * * *

A VERY striking belt buckle seen, simulated a large cluster of daisies with white enameled petals and gilt stamens and pistils.

* * * * *

SILVER jewelry is as fashionable as ever, and does not appear to conflict in the slightest with either the all-gold, the enameled or the gem set.

* * * * *

THE fancy for wearing silver rings, which has been indulged in for some time past by men, it appears, still prevails. The snake rings, with jeweled eyes, are popular sorts.

* * * * *

BRACELETS and bangles are in greater demand than ever, owing to present fashions in dress sleeves.

* * * * *

IN bracelets, as in most other ornaments, there is a long list to choose from. There are solid gold curb chain bracelets with padlocks, flower initial bracelets, solid gold bangles with chased centers, gold horseshoe bangles and gold watch bracelets.

* * * * *

A UNIQUE bracelet seen recently, and wrought in Greek style, consisted of a twisted gold circlet surmounted by two lions, one at either end of the circlet and united by a gold chain.

* * * * *

A QUITE new pocketbook is a card case and purse combined. The folding flap shows silver trimmings and the central compartment, designed for coin, is finished with a silver rim and clasp. On one side of this purse is a pocket for cards, on the other, for bills.

* * * * *

SILVER trimmed leather goods remain fashionable. Black leather is the standard, but all colors are employed.

* * * * *

VERY artistic enamel brooches simulate a spray of dogwood blossoms, in coloring as well as in form.

* * * * *

IN silverware is seen much pierced work. There are very pretty cake baskets with bright centers and open work borders.

* * * * *

QUITE new sugar bowls and cream pitchers are out in bright finish with a decoration of flat chasing, oxidized. These are very effective.

* * * * *

THE new silver picture frames are worthy of special note. These

come in all sizes, from those small enough to accommodate miniature paintings to almost any size that may be desired.

* * * * *

Low forms prevail in silver tableware.

* * * * *

CHASING is a very popular form of decoration, not only for silver table ware but for silver toilet articles.

* * * * *

VERY effective frames are those in pierced work, through which is shown a background of colored velvet.

* * * * *

THE "chappies" are jubilant; for the collection of sticks is this season a wonderful one. They are surmounted by all sorts and kinds of knobs, to say nothing of the crooks and crutches with smoothly finished ends.

* * * * *

MANY of the new walking sticks are worthy of special and separate description. In some instances the sticks themselves are natural curiosities, the value of which is enhanced by the artistic finish of the handle.

* * * * *

A STRIKING feature of this season's umbrellas is an extremely long handle, though the stick remains the same.

* * * * *

UMBRELLA handles, like the cane handles, show a great variety of pattern and finish.

* * * * *

SILVER deposit on ivory, buckhorn and wood, figures in the new handles. There are numerous ball handles of silver in bright finish with chased decoration. Then there are long, somewhat slender handles, showing a combination of bright and chased finish.

* * * * *

A NOTICEABLE feature in clocks are the English chime mantel clocks in mahogany cases with gilt decoration.

* * * * *

THE English chime clocks, as most jewelers know, are in great demand, and to meet this demand they have been made in a variety of cases, such as the mahogany with gilt decoration, and handsomely carved oak and rosewood.

* * * * *

ANOTHER novelty likely to be sought by patrons with long purses, is represented by the French porcelain and gilt clocks. The hand painted decoration on these porcelain cases is worthy the consideration of connoisseurs.

* * * * *

AN especially handsome specimen of these clocks seen, was in old Sèvres blue with gold embellishment.

* * * * *

SILVER clocks recently designed, show Renaissance styles and are likely to prove acceptable as an artistic novelty,

* * * * *

ONYX clocks are very fashionable. A favorite and appropriate

form is that of a massive block of oblong shape, the center being flanked on either side with Corinthian columns. These onyx cases vary greatly in color, including white, a light mottled hue, an exquisite pink and a very rich dark brown color.

* * * * *

DIAMOND half-hoop rings find admirers.

* * * * *

NEW and pleasing patterns are out this fall in bar pins. These pins continue to find ready sale in many localities outside of New York, being special favorites in Texas and Louisiana. New York ladies find them extremely convenient, hence their continued use despite the many newer pins in the market.

* * * * *

ANOTHER old-time favorite that is still manufactured by some of our leading houses is the cuff pin. While cuff pins are largely utilized for the pinning of bibs and children's collars, they are also patronized by many ladies who find them too useful to be laid aside.

* * * * *

MEN'S jewelry is now an important item. The variety in scarfs necessitates in some cases the scarf ring, in others the scarf pin; hence both these articles are in demand.

* * * * *

THE present style of evening dress for men calls for studs, which are furnished in various sizes; these may be of plain gold, gem-set, or of white enamel, according to the taste of the wearer.

* * * * *

A UNIQUE sugar and cream stand is one which consists of two low, round silver bowls held together by the intertwining of an upright handle in the center between the two bowls. The sugar is lifted from the bowl with a long handled silver scoop, while the cream is served with a long handled spoon with deep bowl.

* * * * *

THERE is always more or less demand for initial and monogram jewelry, which is out this season in rustic, floral and other patterns.

Art Glass and Ceramics.

DECORATIVE articles coming under the general head of bric-à-brac were never in greater demand than at the present time. The furnishings of every home, however rich or simple, are supplemented to a greater or less degree with bric-à-brac.

* * * * *

MUCH of this bric-à-brac harmonizes well in a jeweler's stock, and wide awake dealers cannot afford to be without it.

* * * * *

AN ATTRACTION in this season's importations are French porcelain plates with borders of Sèvres blue decorated with gold, that makes a delicate frame work to a beautiful hand-painted picture that decorates the center of the plate. These pictures are genuine portraits of celebrated French court beauties, including the Duchesse du Barry, Duchesse de Lambella, Madame Recamier, and others.

* * * * *

THERE exists a fancy just now for statuettes and busts in alabaster, child figures and faces appearing to be popular subjects. In instance of these may be cited one representing a laughing boy, holding a very young member of the canine species in his tattered hat.

* * * * *

THESE alabaster figures are not confined, however, to child sub-

jects, as is evidenced by a very beautiful Venus rising from the sea, and similar classic subjects.

* * * * *

THE INCREASING demand for large marble figures and busts is most favorably met by the exquisite Carrara marble which, as many of our readers know, is among the finest that the world produces.

* * * * *

A NOVELTY in marble consists of a head of pure Carrara let into a bust of highly polished marble of very dark hue, the joining being quite invisible.

* * * * *

A PLEASING style of small vase is seen in tall slender urn shapes, surmounted with a cover, the body of the vase being of Sèvres or onyx, with gilt handles.

* * * * *

A JAPANESE vase of teak wood with applied ornament of mother of-pearl and carved ivory, contributes a very striking, as well as pleasing, novelty in this line.

* * * * *

ONYX inkstands with gilt racks add to the list of decorative articles for the writing table.

* * * * *

A THERMOMETER, set in a silver mounted elephant's tusk, is included in bric-à-brac for writing desk and library.

* * * * *

FINE bisque figures retain their old-time popularity.

* * * * *

CARLSBAD ivory, or art porcelain as it is also called, furnishes beautiful statuettes, heads, busts and vases, which appear as if carved in real ivory.

* * * * *

THE demand for cut glass is a wide-spread one, and very handsome designs are out to meet it. These new and original designs cast the clumsy old Englishs pattern quite into the shade. Leading patterns in cut glass are the Phoenix, pineapple, prism and bead, passion flower, rose diamond, the sun, strawberry and fan-shaped cuttings.

* * * * *

USEFUL articles in cut glass include ice cream sets and celery trays. The latter are much newer than the tall celery glass.

* * * * *

THE Soudanese ware made in Bohemia, and previously described, continues to find favor with its bottles, jugs and vases, fashioned after the Japanese gourd bottles.

* * * * *

FOR WEDDING and birthday gifts are provided dainty after-dinner coffees, hand painted dessert plates and the like, in satin-lined cases. Ice cream sets and tête-à-tête sets, also put up in handsome cases for presentation purposes.

* * * * *

JARDINIÈRES and decorative flower and palm pots are seasonable objects at the present time. Especially pleasing effects may be

found in the Adderley, also the Leeds ware. In the former ware come flower pots with the blue floral decoration so desirable.

* * * * *

CONNOISSEURS in Royal Worcester, Royal Dresden, Wedgwood, Doulton, and other choice potteries, will be delighted to know that artistic novelties in these various wares are to be had at prices much more reasonable than formerly, when, the demand being less, importations were very much smaller.

* * * * *

IN COALPORT china are to be seen what is known to the trade as Leafage Baskets which are low and flaring in shape with an irregularly scalloped edge and a surface whose flutings are suggestive of foliage.

* * * * *

CONNOISSEURS in fine china continue to find delight in the Belleek porcelains, which rival the old eggshell of the Chinese in their extreme lightness and delicacy.

* * * * *

ATTRACTIVE vases, jugs and ewers of modern Venetian glass are cut to imitate crystal and are profusely decorated.

* * * * *

THERE are some very pretty paper weights, inkstands and decorative bottles in rock crystal. This crystal is cut like precious stones with angles that favor the reproduction of prismatic colors.

* * * * *

READERS looking for quite new shapes in decorative articles at comparatively small price, are advised to investigate the Moorish faience. Where grotesque effects are desired, the Teplitz pottery is suggested.

* * * * *

ART goods in metal continue to meet the popular taste. Conspicuous among these are the high standing parlor lamps, and brass tables and stands with Mexican onyx tops.

* * * * *

STRIKING vases are of Belleek china with elaborate decoration in gold relief and chasing.

* * * * *

CUT GLASS has come to be much used as presents for weddings, The consequence is that dessert sets, berry dishes and the like are shown in satin-lined cases, the same as similar sets in choice porcelains and silverware.

* * * * *

FLAT dishes of cut glass with rolled edges are made for holding after-dinner coffee spoons.

* * * * *

RECEPTACLES for cracked ice come in cut glass bowls with iridescent lights.

* * * * *

BONN ware is decidedly decorative in effect with its tapestry and floral ornamentations.

* * * * *

SOME exceedingly unique shapes as well as pleasing decoration are afforded by the Staffordshire potteries. ELSIE BEE.

Copyrighted 1888 by Charles A. Bucklin.

Mechanical Ocular Defects.

Their Nature, Cause, Correction and Relations to Functional Nervous Diseases.

EDITED BY C. A. BUCKLIN, A. M., M. D., NEW YORK.

[The aim of the author is to produce a clear and thoroughly practical course of instruction on the subject of "mechanical ocular defects," which is entirely void of useless technicalities and within the easy comprehension of every thinking student, without his having had any previous technical or mathematical education.]

HISTORY OF THE THEORY OF VISION.

THE history of how we gradually arrived at the correct theory of vision is of interest to those studying our subject. The first advancement towards the explanation of the true theory of vision was made by a learned Abbe of the name of Francis Maurolycus. He compared the dioptric system of the eye to a convex lens, and stated as his belief that images were formed within the eye in the same manner as they are formed by a convex lens when a screen is held at the proper distance behind the lens. Although this was the first and nearest approach to the correct theory of vision, Maurolycus abandoned the theory on the ground that the images would be inverted, which, if true, in the eye would cause all objects to appear inverted.

As we follow on in the history of the development of the theory of vision, we next meet John Baptista Porta, the discoverer of the camera obscura. He compared the eye-ball to the dark chamber of the camera, and in so doing was entirely correct, but regarding the part which the screen represented in the eye he was entirely incorrect in that he believed that the cornea alone refracted the light, and that the visual image was thrown on the anterior surface of the lens.

It was reserved for the great genius of John Kepler to attain a complete insight into the mechanism of vision. It was he who first discovered and developed the correct theory regarding the effect of the use of spectacles and optical instruments in general. He founded with one stroke all the phenomena belonging to this subject with such clearness and perfectness that but little remained for his followers to do. In his two imperishable essays on this subject, the one entitled "Ad Vitellionem Paralipomena" which appeared in Frankfort in 1604, and the other entitled "Dioptric," which appeared seven years later in Augsburg, he says that upon the retina an inverted image of the observed object is thrown, and he further stated that the conditions always necessary for distinct vision were that the image be clear and sharp.

Prof. Helmholtz in his "Physiological Optics," gives Christopher Scheiner the credit of having first demonstrated the formation of the inverted image on the retina by removing the sclerotic and choroid, and he also gives Scheiner credit of having made the same experiment on a human eye in Rome, in 1625. Mauthner, who has carefully read the noted works of Scheiner, quoted in Helmholtz's "Oculus Sive Fundamentum Opticum," which appeared in Innsbruck in 1619, and which later appeared in London in 1652, states that the demonstration of the retinal image is not considered.*

The demonstration of the retinal image was first described and illustrated by Des Cartes in 1637.

Although the subject of the theory of vision has been for years a field for more active discussion, still with the exception of the particular part which different portions of the dioptric system played in the combined refraction which takes place within the eye, the subject was quite as well understood in 1700 as it is to-day.

Other parties opposed the theory that the retina received and

* Helmholtz being a great man and Mauthner being equally great as a critic in Ophthalmic literature, it is inexplicable to the author how either man could be mistaken.

appreciated the visual impression. They held that the choroid was the sensitive layer which received the visual impressions. They based their conclusions on the fact that all portions of the fundus covered with choroid were sensitive to light and only that portion occupied by the optic nerve which was not covered by the choroid was incapable of reserving light impressions. The argument appeared sound and had many ardent followers, but the conclusions were absolutely wrong. The light impression is reserved entirely by the retina and the choroid takes no part in its reception or appreciation.

Having demonstrated that the eye is a physical instrument, we are now in a position to pass on to its consideration as a monocular and binocular optical instrument.

MUTUAL RELATIONS OF REFRACTION, ACCOMMODATION AND CONVERGENCE.

An "emmetropic" eye is one of proper length and perfect shape. To all other eyes we apply the term "ametropia." If we examine an emmetropic eye we will find that it has a dioptric apparatus which in a state of rest has just the refractive power necessary to cast a sharp image upon the retina when parallel rays of light enter the eye.

Monocular ocular defects are those which produce defective, painful or weak vision, *notwithstanding one eye is excluded from the visual act.* It does not indicate that the difficulty is confined to only one eye.

Binocular visual defects are those which do not annoy when one eye is excluded from the visual act; but which become annoying as soon as the complicated requirements for binocular vision are made necessary by the use of both eyes. Either one or both of the above defects may exist at the same time.

Refraction is a term used to express the condition of the eye when the accommodation is in a state of rest—thus the refraction of an eye which throws on the retina a sharp image of objects from which parallel rays of light come, is called Emmetropic. When the eye is so long that the image formed by parallel rays of light falls in front of the retina the refraction is called *myopic* and the greatest distance from the eye at which given objects must be held to give the rays of light the necessary degree of divergence to cause the retinal image to fall on the retina enables one to compute the degree of the myopic refraction. When the eye is too short the refraction is called *hyperopic*. The retinal image formed by parallel rays must fall behind the retina and the image can only become focused on the retina by the use of the accommodation or convex lenses.

It is easily comprehended how these two errors of refraction, known as hyperopia and myopia, may produce both *monocular* and *binocular* ocular defects. In hyperopia, although the accommodation easily compensates for the defect when one eye is used alone, yet when both eyes are used the degree of convergence necessary to direct both eyes at a given object is a fixed quantity, and with a fixed degree of convergence it will frequently be found impossible to produce the necessary amount of *accommodation*, while with one eye it was possible to accommodate sufficiently. On the other hand, in myopia of a degree equal to $\frac{1}{12}$, no accommodation is required till an object is brought nearer than twelve inches. Accommodation and convergence being so intimately connected, it will frequently be found impossible to maintain convergence where no accommodation is required, and it is still more difficult when the myopia is of so high a degree that the observed object must be held at four or six inches distance. This makes an excessive degree of convergence necessary with absolutely no corresponding accommodation; consequently we have binocular optical defects, produced directly by hyperopia and myopia.

In monocular vision the correction of a given degree of hyperopia or myopia by a convex or concave lens which compensates for the defect is very simple, but as most individuals have binocular vision the conditions necessary to satisfy are very complicated when both eyes are used. The very correction glass which compensates for the

error of refraction may so completely disturb the relations existing between accommodation and fixation that it is absolutely impossible to tolerate the lenses. This difficulty is one of the greatest we encounter in selecting proper lenses, and it creates great confusion in the minds of those commencing the study of this subject. An individual complaining of weak, defective or painful vision must have one of the following conditions: *An error of refraction or accommodation; a disturbance of the natural relations existing between refraction and convergence; an obscurity of vision; a disease of retina, optic nerves or brain; a neuralgic or inflammatory affection of the eye.*

After having considered in detail the nature and peculiarities of the above mentioned conditions, we will consider the determination of their existence and the proper treatment under a special chapter entitled *Systematic Examination of the Eyes.*

The School of Optics will form a class for October to accommodate those desiring to study this subject in a practical way. Particulars will be furnished upon application.

Two Recent Optical Inventions.

WE GIVE below descriptions of two recent improvements in the manufacture of optical instruments which contain several points of interest to our readers. The first refers to an astigmatic eye-piece for optical instruments for whose conception Joseph Kornblum, Pittsburgh, Pa., and others are responsible.

It is well known among oculists and opticians, that fully one-half of the people who wear glasses are troubled with astigmatism, a defect of vision caused by difference of refraction in the horizontal and vertical meridian of the observer's eye. Persons having this defect of vision see objects distorted in a horizontal or vertical direction, or at some intermediate angle. The lenses of the eyes of such persons, although approximately spherical, are slightly cylindrical. To correct this defect, eyeglasses are made in the form of a segment of a cylinder upon one side, and upon the other entirely plane, spherical or concave, according to the requirements of the case, while the cylindrical surface may be either convex or concave, according as the patient is near or far sighted.

Persons seriously affected with astigmatism are unable to use telescopes, opera glasses, microscopes, or the class of engineering instru-

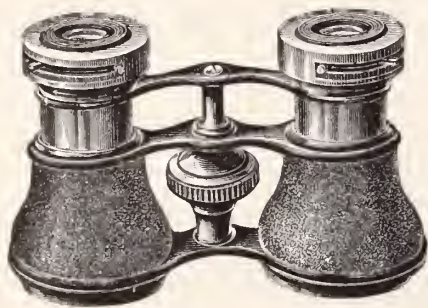

FIG. 1.

ments employing telescopes. The eye-piece above mentioned practically corrects all astigmatism when applied to the instruments.

Although this improvement applies to almost every kind of optical instrument, we will here describe its application to an ordinary opera glass, as shown in the engraving, fig. 1, which is a perspective view of an opera glass, while fig. 2 is an enlarged perspective view of the eye end of the glass, showing the details of the improvement.

The improvement consists in applying to each eye lens cell an extension in which is pivoted a frame containing a ring, which in the present case is revoluble, and in arranging in these rings auxiliary lenses of cylindrical form adapted to compensate for the cylindrical

curvature of the eye lens. These lenses are especially fitted to each case, and when once arranged at the proper angle, they are secured so that they rest in a pivoted frame, but they may be swung out of the field of vision, as shown in fig. 2, so that the opera glass may be used like any other by a person having normal eyesight.

The second is a self-adjusting eyeglass frame, of which Fred. W. Nolte, with the Mermod-Jaccard Jewelry Co., is the inventor. The frame contains several points of differences from other frames, which are of the nature of improvements. First, it has a bridge similar to a spectacle bridge and thus does away with the large spring and

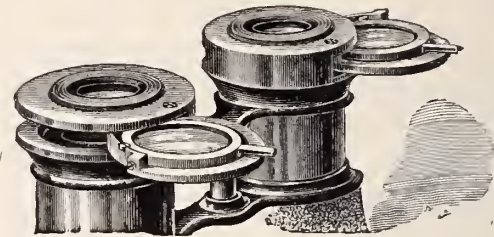

FIG. 2.

straight bar which in many cases are ugly and objectionable; second, by its construction it allows the glasses to set perfectly straight before the eyes of the wearer—a desirable feature for the use of distance and cylindrical lenses; third, the nose-pieces adjust themselves to the thickness of the nose; in the generality of eye-glass frames made, the pressure of the nose-pieces is unequal, they giving way mainly at the top which is the fleshy part and can stand considerable pressure without annoyance, whereas, the lower or bony part of the nose which is very susceptible, is pressed hard and great discomfort caused.

The frame contains no spiral springs, screws or rivets, and is composed of very few pieces; these can be taken apart without the help of tools. A wider, narrower, deeper, or shallower bridge can be put in in a short time.



The cut shows the eye-glass as it appears on the nose. The broken lines indicate the manner of placing the glasses, the lower parts of the nose-pieces spreading apart to allow of adjustment to the lower thickness of the nose.

Improved Arbor for Clocks.

AS IS known, in the clocks made by existing systems, in order to remove the mainspring and wheel, it is necessary to so loosen the plate on one side of the frame so that the bearings of the arbor can be lifted out, and this frequently so loosens and disarranges the other gearing that it is a considerable trouble to replace the parts, even by an experienced workman. Especially does this fault exist in striking clocks, as the teeth of the gears have to be adjusted to a given position in replacing in order to produce the proper motion of the striking mechanism. So, devices for removing the spring and wheel without disturbing the other parts are desirable, and, with a view to attaining this result, E. M. and Mark Moulton, of Rochester, N. Y., have perfected and patented an arrangement of which below are given its features.

The plates, pillars and wheels are not changed—in fact, no remodeling has been effected excepting with the arbor, which is so constructed as to allow of its being detached from the plates and the inserting of a new spring, and the replacing of the arbor without taking the clock apart. It further admits of the small, intricate parts

of the train to be set up and adjusted without the accompaniment of the main wheel or barrel, thereby lessening the intricacy of the work, as the main wheels, being larger than the other portions of the mechanism, ever and underlap those parts, and cause, frequently, considerable trouble before the plates are pressed down.

The essence of the improvement lies in the construction of the arbor and its attachments. *E* is a screw forming this arbor. It is cut with an external thread, *d*, that fits the internal thread of a hollow sleeve, *D*; it has a shoulder *f*, which, when it (the arbor) is screwed in the sleeve, strikes the shoulder *b* of the latter, and thus clamps

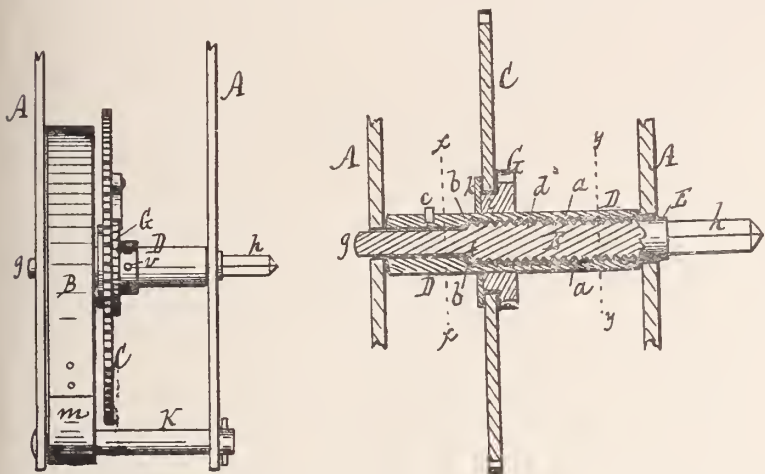

the screw to the sleeve by the frictional contact. The whole length arbor is of such diameter that it can be unscrewed and drawn out endwise through the bearing in the plate, by the winding stem *h*, leaving the sleeve free; the latter can then be removed from the frame without difficulty, inasmuch as it fits easily between the two side plates, *A, A*, and is detachable from the mainspring by means of the hook *c*, which is riveted to the mainspring, and is attached to the pillar or sleeve by simply hooking on. When unhooked, the mainspring and wheel can be removed without displacing any other parts. The frame is connected by the usual pillars and requires no change whatever in construction. The hook is of sufficient strength to sustain the strain and its great advantage is the facility it affords for readily connecting and disconnecting the mainspring.

If desired, a small pin or screw, *v*, can be driven through a hole in the sleeve and arbor to attach them together and prevent unturning of the screw if the arbor is turned backward.

The History of the Bracelet.

THE *Moniteur de la Bijouterie et de l'Horlogerie* deplors that its own government (the French) permits valuable private collections to be sold at auction and drift apart in this manner, for the want of funds to acquire them for the state. The English museums, it says, more richly endowed than theirs, hardly ever permit a chance to escape them to buy whole collections; for instance, that of Kensington, in London, has just bought at a high figure three or four hundred pieces of rare jewelry, constituting a complete history of the bracelet. The owner of this collection, Sir Harris Grant, had spent forty-five years in collecting it, and the London journals speak of it in high praise. It was, a few years ago, described in an (French) art review.

The history of the bracelet is a chapter of the history of coquetry. It is one of the most ancient of jewels. Among the Israelites, the gold bracelet was used alike by the two sexes; when Juda encounters Thamar, the latter asks in exchange of favors, his staff, his ring, and his bracelet. When Saul had perished by his own sword, a warrior despoils him of the bracelets with which his arms are covered.

“For the construction of the Tabernacle,” it is said in the Exodus,

“both men and women offered their jewelry, among which were quantities of rich bracelets.”

The Greeks and Romans also wore bracelets. After a time the latter abstained from wearing them daily; they were conferred as a mark of distinction, as a souvenir of some great act, and the possessor guarded them consequently as glorious decorations, and contented himself with suspending them upon his breasts on days of ceremony and triumph—in the same manner as a general to-day wears his orders and insignias. In this manner the bracelet became the insignia of the warrior. The plebeian classes, courtezans, dancing girls, and others, wore them around the wrists and ankles.

Our ancestors, the Gauls, were also great lovers of the bracelet. At Pont-Audemer is to be seen a magnificent gold bijou of this kind, very finely worked. It is attributed to the first part of the reign of the Merovingians.

At the commencement of the sixth century, no trace is found of the bracelet in France. A revolution has been effected in wearing apparel as well as morals. Ladies' wrists are ornamented with large, colored silk cuffs, embroidered with gold and pearls. ‘This fashion ends with the Carolingians. When was the time that fashions prevailed longer than one dynasty? Later on, ladies wore tight and buttoned sleeves, terminating at the wrist; in the twelfth century, Jean de Garlande specifies the works made by goldsmiths: hanaps (large cups) of gold and silver; necklaces, pins, knots and rings—but nothing is said of bracelets. Finally, “manacles” were used; they were a sort of bracelet composed of a piece of stuff upon which jewels were sewn, until finally in the last half of the fourteenth century, the true metal bracelet appeared. It seems that it was worn by gentlemen, although secretly, as a kind of vow, a badge of servitude which they pledged to the lady of their thoughts. The history of Jehan de Saintré, Chamberlain of King Charles VI., and of the Lady des Belles-Cousines, bears witness to this. When Jehan de Saintré vows eternal fidelity to his lady, she demands of him to constantly wear an emblem of attachment. “On the first day of May, which will be to-morrow,” she tells him, “you will place a gold bracelet of some kind or other on your left arm, and wear it for a year.” Next day he comes with the bracelet which he is to wear, and the lady herself puts it on. From about that time this piece of jewelry has been called “bracelet.”

From about the middle of the fifteenth century, the bracelet becomes a distinctive piece of ornament among French ladies. At the time of the “Directoire,” the women who had adopted the fashion of wearing a robe *à la Romaine*, ornamented their arms with six bracelets, three on each arm; one high up, another above the elbow, the third at the wrist. This is not all, however; they also wore rings on all their fingers, including the thumb; encircled their waist with a large sheet as belt and wore large hoops in their ears. A French lady dressed *à la sauvage* (in a *savage* style), wore flesh-colored tights, over which was thrown a simple linen tunique, gold hoops around her thighs and legs, diamond rings on her toes, while on her feet she wore sandals.

About 1830 bracelets assumed a great importance, and ranked even with literature and painting; in other words, they became “romantic.” Although it may appear rather bombastic to assign so high a place to a piece of jewelry, nevertheless nothing will qualify so well the artistic tendencies in this direction of the goldsmiths of that epoch. Bracelets appeared on the arms of ladies, composed entirely of pointed arches, in the midst of which iron-clad warriors kept watch and ward. It is easy to imagine the enthusiasm with which they were received, being so well in keeping with the tendency of the people.

At present, finally, the fancy and caprice of the day dictate to the jeweler the shape, either new or copied from former ages, to be given to their bracelets; sometimes a serpent twisting itself around the wrist, gold hoops with a long jewel, a chain, etc. The shapes vary to the infinite at present, and many of them are due to the ingenuity of our jewelry designers.



CYLINDER PLUG FOUL OF WHEEL.—Should the bottom plug of the cylinder be found foul of the scape wheel, the cylinder can be lowered by shortening the lower pivot, bending the cock down a little to correct the end shake; should the pivot not be long enough to admit this, the shoulder must be turned back and repolished. In the event of its being a square-shouldered pivot, the triangular burnisher used on the Jacot tool will be safest, as, by this means, not only is it impossible to break off the pivot, but it will not be smaller at the shoulder, a thing very likely to happen with the turns and polisher. Should the balance, by being lowered, become foul of the scape cock, it must be raised by its bars until free, trying it in the calipers until true.

FUSIBLE CEMENT.—The *Journal Suisse d'Horlogerie* says that a good, easily fusible cement for fastening glass and porcelain upon a metallic surface can be prepared as follows: Brass powder in form of a sediment, which has been prepared by laying zinc in a solution of sulphate of copper, is placed into an iron or enamel mortar and mixed with concentrated sulphuric acid of 1.85. To this paste add seventy parts of quicksilver to twenty or thirty parts of brass, according to the hardness desired. When the mixture has been well united it is carefully rinsed in warm water, so as to expel every trace of acid from it, after which it is left to cool. After a few hours the ready cement will be so hard that tin can be scratched with it. For use, it must be previously warmed, so that it can be worked in the mortar, whereby it becomes as soft as wax. In this state it is spread out upon the metallic surface, and the object to be fastened (glass or porcelain) is pressed upon it. When the cement has become sufficiently cold it retains with great tenacity.

EXTRACTING SILVER.—When you have a quantity of refuse from which you wish to extract the silver, mix the former with an equal quantity of charcoal, place in a crucible and heat to a bright red, and in a short time a silver button will be found at the bottom. Carbonate of soda is another flux.

TO TAKE IMPRESSIONS FROM SEALS.—To take an exact model of any coin, medal, embossed stamped paper, or, in fact, any raised or imprinted device, cut a piece of cardboard with which form a ring just the dimensions of the impression to be taken, then pour within the said ring melted fusible metal. The cardboard will prevent the metal from running away, and in a few minutes it will cool and the impression taken will be the same as the original, but reversed. A good fusible metal for this is a compound of eight parts of bismuth, five of lead and three of tin, which liquifies at the temperature of boiling water.

GOOD SUBSTITUTE FOR BRONZE.—Thirty parts of good brass (thirty-five parts of zinc, sixty-five parts of copper) and four parts of phosphor tin No. 0.

SILVERING IRON.—A manufacturer in Vienna employs the following process for silvering iron: He first covers the iron with mercury and silvers by the galvanic process. By heating to 300° C., the mercury evaporates and the silver layer is fixed. Iron ware is first heated with diluted hydrochloric acid and then dipped in a solution of nitrate of mercury, being at the same time in communication with the zinc pole of an electric battery, a piece of gas carbon or platinum being used as an anode for the other pole. The metal is soon covered with a layer of quicksilver, and is then taken out and well washed and silvered in a silver solution. To save silver, the wire can be first covered with a layer of tin; one part of cream of tartar is dissolved in eight parts of boiling water and one or more tin anodes are joined with the carbon pole of a Bunsen element. The zinc pole communicates with a well cleaned piece of copper, and

the battery is made to act until enough tin has deposited on the copper, when this is taken out and the iron ware put in its place. The wire thus covered with tin, chemically pure and silvered, is much cheaper than any other silvered metals.

TO POLISH A SCREW.—Finishers generally use the old English screwhead tool for producing the beautiful "tallow top" screws used in English work. This tool is a mandril running in one bearing with an overhanging ferrule, and the rest for the polisher. The screw, the head of which is to be polished, is put into a chuck, of which there must be a sufficient variety to suit all the ordinary run of screws. Tool marks are usually first removed with a slip of oilstone and the polishing finished with redstuff or diamantine. With a long bow screws are polished very expeditiously in the English tool, but it is not so handy for the repairer who uses a great variety of different screws. For repairing, the Swiss screwhead tool is generally used. There are a number of different sized holders, lined with brass so as not to injure the tops of the screws. It is important to use one of the right size, for if too small in the hole, the screw is sure to be marked. The holders are sprung open and a sliding thimble serves to nip them together sufficiently to grip the screw to be polished. The holders are rotated by rubbing the palm of the left hand to and fro over the octagonal body. The polisher rests on a roller, to permit of smooth running. The upper arbor projecting from the body of the tool is to receive a lap which is pressed against the work and slightly rotated to and fro by the thumb and right finger of the right hand, while work in the holder is rapidly rotated with the left. Two nearly semi-circular laps are generally screwed to one holder; one is of soft steel and the other of gun metal. Lanterns are used for polishing the ends of fusee squares. Smaller ones of the same kind are used for holding screws so that the tops and points may be polished as described in speaking of the English tool.

POLISHING.—The tool used for producing the beautiful polished and square surfaces to be found in watch work may be divided into two general classes—first, those used where the work is rigid and receives a reproduction of a previously squared surface, and, secondly, where the work is "swung," or arranged so as to yield to unequal pressure in polishing. Polishers for steel are either of soft steel, iron, bell metal, tin, zinc, lead or boxwood. They must be in all cases formed of softer material than the object to be polished; for instance, bell metal, which brings up a good surface on hard steel, is unsuited for soft. Polishers for brass are generally of tin or boxwood, with willow for finishing. The polishing medium is either emery (which is used for gray surfaces), oilstone dust, redstuff or diamantine, used with oil. Brass surfaces are generally "stoned" preparatory to polishing—that is, rubbed square with bluestone or water of-Ayre stone and water or oil.

POLISHING RAGS.—These rags, which are excellent for polishing metal surfaces, are prepared in the following manner: Dip flannel rags into a solution of 20 parts dextrine and 30 parts oxalic acid in 20 parts logwood decoction; wring them gently and sift over them a mixture of finely pulverized tripoli and pumice stone. The moist rags are piled upon each other, placing a layer of the powder between them. They are then pressed, taken apart and dried.

BUSHING ALLOY FOR PIVOT HOLES, ETC.—Gold coin, 3 dwts.; silver, 1 dwt., 20 grains; copper, 3 dwts., 20 grains; palladium, 1 dwt.; the best composition known for the purpose named.

TO FIT THE DIAL FEET.—Grind away the enamel where the feet are broken off, with the emery lap, and turn up two new feet, shaping them the same as a plate screw, the part corresponding to the head being large enough to get a strong hold when soft soldered to the copper plate of the dial. Solder them on so that when fitted on the plate, the center of the seconds hole will correspond with the hole in the fourth or second wheel jewel, mark the points to drill for the dial pins so that when the pins are inserted they will touch the plate and thus keep the dial from rattling.



LARGE TELESCOPE.—A monster telescope is at present being erected within the grounds of the Paris Observatory, the tower of which has just been finished. This tower is square, of two stories, eighteen meters (59 feet 6.65 inches) high, and ends in a terrace which serves as a support for the new instrument. The tower stands upon a foundation, upon which is also a broad platform to receive the mechanism for controlling the instrument. The telescope itself has cost 240,000 frs., to which adding the cost of the building, 120,000 frs., makes a total of 360,000 frs. It is calculated to have the new establishment ready by October 15th, as several scientific congresses meet on that date at Paris.

SOUND ADVICE.—The congress of diamond workers, which recently convened in Paris, recommends the publication of the following advice to parents in all regions remote from the great centers of diamond and jewelry setting. It says that parties seek to establish this precious stone cutting industry in out-of-the-way places, and hold out great inducements, such as large salaries, etc. The fact is that the resources of this industry are very limited at present. The market is overcrowded with workmen; Holland has about 5,000; Belgium 2,000, and the time is out of mind when all of them were engaged at work at one time. There recently were long continued strikes in Paris and the Jura, and at this moment, in Paris, half the cutting establishments are closed, and a number of workmen have been on a strike for the past three weeks. This dolorous situation recurs every year at this season, while, during the remainder, there is just about enough work for the workmen to make both ends meet. Heads of families are therefore cautioned not to be deceived by these glittering promises, and not to let their children learn the jewel cutting trade.

DISTINGUISHED VISITOR.—Mr. Carnot, the President of the French Republic, visited the diamond cutting establishments at the Paris Exposition and inspected the show cases of the Cape Mining Company. Diamantiferous earth was washed in his presence and a large diamond was split. A bouquet and two brilliants were tendered him. He admiringly inspected the mechanism by the aid of which the showcase containing both the large cut and uncut diamonds of the Bultfontein mines are lowered six meters under ground every evening. Twenty-four keys are necessary to operate the apparatus.

RENOWNED SEAL.—Messrs. P. & O. Luther, of Berlin, are in possession of a seal which once belonged to Dr. Martin Luther. Their family comes from Wittenberg and counts to the direct descendants of the great reformer. The seal is of brass, and two inches long. Upon its knob is engraved in the hand-writing of Luther, his name "Dr. Martin Luther." The plate is divided into three fields containing a white rose and a swan. The year 1521 is engraved on one side of the fairly thick plate.

COMING TO NEW YORK.—A large find of antiquities was recently made in Rome, to wit: a bronze memorial column of the Emperor Geto (brother of Caracolla, who had him assassinated), as well as half a Roman viga and a Lombardian grave with an iron coat-of-mail, and valuable gold ornaments. The articles were sold for 270,000 frs. to the Metropolitan Museum of Art, New York.

GOOD SALARIES.—According to *Le Petit Journal*, the French diamond cutting establishment of Mr. Roulina has, since its foundation, paid "ten million francs salary to five hundred workmen which it employs." This gives to each workman—counting only fourteen years of existence of the shops, and including the four years of apprenticeship—the sum of 2,000 francs, or 40 francs per week. A contemporary makes the sneering remark: The statistics of this establishment exhibited at the exposition of 1878, showed the salary to have been until that time 100 francs per week! These statistics have not been dishd up again this year—and for good reasons.

PRODUCTION OF DIAMONDS.—We cull a few results from *Afrique Minière*, to show that the production of diamonds continues unabated. The *De Beers Company* announces the payment of a half-yearly dividend of 10s., for July 1, and proposes to pay one of 15s. Jan. 1, 1890. The *South African C. L.* reports its work during the week ending June 1, 1,548 carats of diamonds, valued at £1,857. The *Anglo African D. M. Co.* reports its week's work, ending June 22d, £1,240 clear of all expenses; same company reports week's results ending July 6, £1,000 clear profit. The directors of the South African Co. received the following telegram as the result of the week ending July 8: 1,483 carats of diamonds, at the estimated value of £2,450.

REGATTA PRIZE.—The Imperial prize which the Emperor of Germany in person presented to the victors in the regatta at Kiel consists of a silver goblet in the shape of a vessel, supported upon a columnar golden stand. This is surrounded by marine animals shells, and corals, bathed by the waves, and the whole is on one side supported by a dolphin, and on the other side by a water nymph, that carry the ship. The support rests upon a reddish marble plate, one side of which contains the escutcheon with the dedication. The names of the victors are to be engraved upon it. The ship itself has golden riggings and silver sails swelled by the breeze. An angel stands at the helm. The golden flag is engraved with the German coat-of-arms, the Imperial eagle.

VALUABLE CAT'S EYE.—The most valuable cat's-eye in the world arrived recently in London. It comes from Ceylon, which and Madras are the only two places where these jewels are found. The finder was a laborer, who discovered it in some earth with which he was filling his wagon; it weighed 474 carats, and he sold it for 30 rupees. It changed hands several times, was recently cut, and weighs at present 170 carats. It is insured for 30,000 rupees. The stone emits four rays of light, which unite into one.

MARS AND SATURN.—Lovers of astronomy enjoyed a very rare treat last month. On September 20, the two planets, Mars and Saturn, approached so closely to each other that their mutual distance, as seen from the center of the earth, was only 54 arc seconds. Since double stars of equal brightness can by a trained eye be recognized as two stars only when they are distant from each other at least from four to five arc minutes, or about five times the above expressed value, these two large planets obviously melted into each other and appeared as though one. And to still add to the unusual interest of this highly rare phenomenon, a third star assisted in making it a marvel of ages. At the commencement of the conjunction, both stars stood in close proximity to the brightest star in the constellation Leo, viz., Regulus, and distant from this only four arc minutes, so that also the light of this melted into the brightness, and the three stars apparently formed one. Three days afterward, the morning star, Venus, also passed by Regulus within only twelve arc minutes. A second approach occurs on November 1, but is of little interest to the layman, as it is invisible to the naked eye.

THE AGE OF RINGS.—The first known jewel was the ring, which we find in all historical documents from the earliest time. For many centuries rings were current coin, and were used as such by the Egyptians until after the dynasty of the Ptolemies, that is, until Greek princes reigned over Egypt, and introduced the Grecian coinage. Rings were also used as signets, and served to attest public documents and private contracts. The Egyptian Scarabee had a name or inscription cut into the lower surface which made it available for the making of an imprint in wax or any other plastic substance. Soon the art of cutting intaglios made great advance and reached, so many think, its highest degree of perfection about 200 B. C. But the writer does not share this latter opinion, for the art of intaglio as well as that of cameo cutting was never so far advanced, in an artistic point of view, as at present, for the simple reason that the ancient masters had no lenses to assist them in their work. The engravings by one of the foremost gem cutters of ancient times, Dioscorides, will not bear close examination with a sharp magnifier.

Repeating Arrangement for Watches and Clocks.



GERMAN inventor has obtained a German Imperial patent for a novelty, which, to judge from the following illustration and description, appears to have points of merit worthy of the consideration of the readers of *THE JEWELERS' CIRCULAR*. The inventor had made it his aim to construct a repeating mechanism that can be introduced into watches and clocks at a comparatively cheap price, so that men of moderate means might possess a timepiece which will tell them the hour "in the dark hours of the night," when neither dial nor hands

are visible. We take the cut from the *Deutsche Uhrmacher Zeitung*.

The repeating mechanism under review consists of only one lever work, for the actuation of which neither a mainspring nor a separate train is required, as it is operated by pressing a button outside on the case rim, whereby it strikes the hour and each five minutes upon the gong. The strokes resound upon one gong, and after the hours are struck a double stroke indicates that these have ended, and the next succeeding strokes are for the five-minutes. The motion work of the watch has hereby the same functions as that of every ordinary repeating watch—it revolves the minute snail upon the cannon pinion and hourly displaces the star wheel carrying the hour snail.

The entire lifting work is located upon the upper side of the plate underneath the dial, except the hammers and the gong, which are lodged on the lower side of the plate, near its rim.

Accompanying cut shows the repeating mechanism on an enlarged scale, for sake of greater distinctness, and in the condition with simply the dial removed. The position of the pieces arranged on the supposition that an unlocking of the mechanism has taken place at 12:35.

In studying the illustration, we will notice first the well-known 12-toothed star wheel *a*, with the hour snail *b*, the jumper *a'* and the spring *a''* operating upon it. We further notice the canon pinion *c* with the five-minute snail *d* and the arm *d'* lodged movably underneath it, which effects in the known manner the hourly progression of the star wheel *a*; *e* is the hour rack with projection *e'*, and *f* the minute rack with projection or gathering pallet *f'*. Both racks are one over the other upon the joint steady pin *g*, located so that they can revolve independent from each other. The pressure springs *e''* and *f''* actuate upon the hour rack *e*, or minute rack *f*, and cause at the suitable moment the dropping of the racks upon their snails. Both racks have each a separate pawl, *h* and *i*, which are similar to the racks located one above the other upon one joint steady pin, *k*, movably but independent from each other. The split pressure spring *k'* operates upon both pawls, endeavoring always to press them into the teeth of the racks.

The mechanism further consists of a two-armed lever, *o*, which revolves around the screw *o'*. At its lower end is located the movable push piece *p*, which with its curved, edge-like point, alternately catches into the teeth of the two racks, whereby it is aided by the spring *p'*.

The unlocking of the repeating mechanism occurs in the following manner: The exterior projecting button *m* is seized with the fingers, and the slide *n*, fastened thereto, is drawn out as far as can be done. By this procedure, the pin *n'* raises the push piece *p* until it abuts against the two pawls *h* and *i*, and lifts them out of the teeth of the racks. The thus liberated racks drop under the co-operation of the pressing springs *e''* and *f''* with their projections upon the corresponding snails, and attain the position represented in the cut. In

order next to lead both racks tooth by tooth for each stroke back again into a position of repose, a two-armed lever, *q q*, which can revolve around screw *q'*, is located; after every pressure upon the button *m* it is carried down by the pin *n'* in the pusher *n*, and after accomplishing its purpose it is raised again by the operation of the very powerful spring *r*. As is visible in the cut, the short arm of the lever *q q*, when pressed down, moves upward and thereby also presses upward the short arm of the lever *o*, movable around the screw *o'*. By this mutual motion, the lower end of the lever *o*, to which is fastened the push pawl *p* seizing into the teeth of the racks, is carried to the right, and thereby after every pressure upon the button *m*, first the upper rack *e* for the hour stroke, and next the push pawl now dropping upon the lower rack for the minute stroke, also this is led back into the position of repose. By every pressure upon the button *m* and release, the push pawl *p* therefore receives a to-and-fro motion, whereby it is enabled to carry back the racks, tooth by tooth. The two pawls *h* and *i*, after the operation of the push pawl *p*, drop into the teeth of the racks and firmly maintain these in the position imparted to them by the push pawl.

In the position of repose, each of the two racks reclines against a

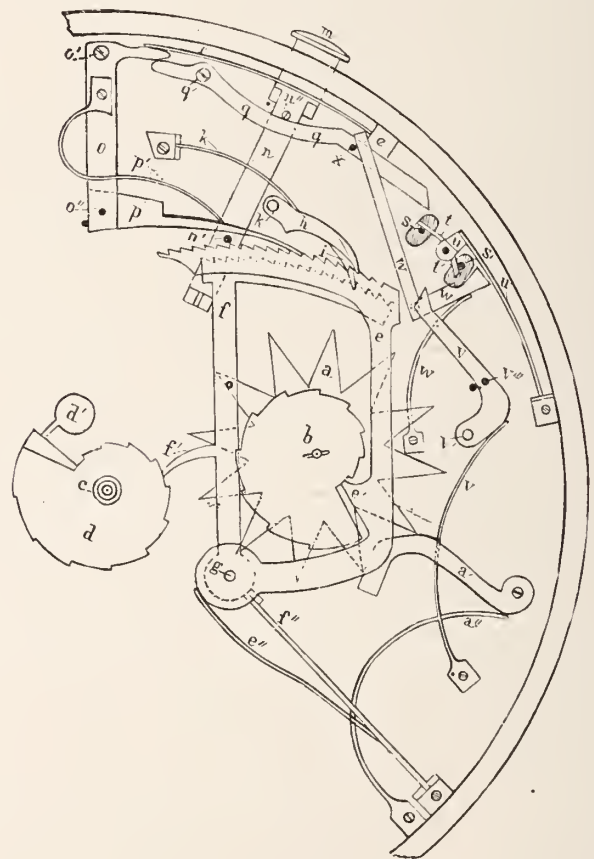

pin, whereby a further pressure upon the button *m*, until the re-unlocking of the racks takes place, is without effect.

It next remains to consider those parts of the mechanism by which the hammer strokes are effected upon the gong. As above specified, the two hammers, together with their pressure springs, as well as the gong, are located upon the inner side of the plate, consequently they are not visible in the cut; this, however, will in no manner render more difficult the understanding of the disposition, more especially as the arrangement of the hammers and gong is almost identical with that of the ordinary repeating watches.

In each of the hammers is introduced a lifting pin, both of which pass through correspondingly large openings in the plate and protrude beyond it upon the front side at *s* and *s'*; *t* is the lever for the hammer, which strikes the hours and minutes upon the gong, and *t'* for the signal hammer for producing the double stroke after the completion of the hour strokes. This double stroke is the signal that the next following strokes produced by the pressing down of the but-

ton *m* indicate the number of five minutes which have elapsed since the full hour. The hammer levers *t*, *t'*, are arranged one above the other upon a joint steady pin, but in such a manner that each may move independent from the other. The correspondingly formed pressure springs *u*, *u'*, serve for throwing back the levers into their position of repose after having lifted the hammers.

By throwing another glance upon the accompanying figure, we notice that the previously mentioned two-armed lever *q*, which with its short arm sets into motion the push pawl *p*, by pressing down, hits with the long arm upon the lever *t* of the hour, respective minute hammer, raises it, and by drawing back lets it go again, so that lever *t*, under operation of its pressure spring *u'*, flies back again into its position of repose. We will also notice the lever *v*, which is located freely movable upon the steady pin *v'*, as well as the pressure spring *v''*; the latter throws the lever *v* downward, when the hour rack is unlocked and drops with its projection upon the hour snail. When, now, the rack *c* is in the previously mentioned manner carried back tooth by tooth, it finally arrives upon the pin *v'''* in the lever *v*, and raises it. Its front end hereby raises the lever *t'* of the striking hammer, which is then by another lever, *w*, kept raised until the suitable moment, which is done in the following manner: The lever *w*, aided by the pressure spring *w'*, leans with its long front arm on the pin *x* fastened in the lever *q*, so that by the pressing down of the slide *n* it catches with its shorter hind arm the lever *t'* of the signal hammer, and keeps it raised until the slide *n* goes back again, whereupon the signal (double stroke) will occur as notification that the minute stroke will ensue next. This double stroke, of course, is not to be counted.

The operation of the above described mechanism, now, is as follows: If the time indicated by the hands upon the dial is to be made audible, the slide *n* is first to be drawn out by means of the button *m*, whereby the two racks are unlocked and by the pressure springs forced against their snails. When, next, a pressure is exerted upon the button *m*, there occurs, as often as it is done, an hour stroke, until the signal hammer (in the present instance 12:35), after having struck 12 times, announces the commencement of the minute strokes, after which, the pressure upon the button being continued, the next ensuing strokes are counted for each five minutes; in the present case, after the warning stroke, striking ceases entirely after seven pressures, and the inquirer knows that it is 12 o'clock and $7 \times 5 = 35$ minutes. If, for instance, the hands indicate exactly one o'clock, or one o'clock and four minutes, the mechanism, after the drawing out of the button *m* and pressing upon it, sounds only one stroke; if it were 1:16, it would strike first the hour stroke, then the double stroke, and next three other strokes for the $3 \times 5 = 15$ minutes, etc. After the time has been struck, the continued pressure upon the button produces no further results, since the two racks have assumed their positions of repose, and would operate again only after another unlocking.

The mechanism works with entire certainty, and since the operator has it in his power to regulate the speed of the strokes, there is barely an opportunity that an equivocation should occur.

BALANCE SPRINGS.—A soft spring, even when perfectly adjusted, on being bent and brought back to its former position, will be no longer isochronous in its vibrations. If the experiment be repeated a few times, the elastic force of the curve will soon become so small compared with that possessed by the body that instead of exercising a power over the latter, its motion becomes subservient to it. A hard spring will bear a much greater amount of over manipulation than a soft one, and a Breguet spring, the form of which in itself necessitates a certain amount of bending, must naturally possess a greater degree of hardness than helical springs.

Universal Watch.

AMONG those, says the *Revue Chronométrique*, who have endeavored to solve the problem of indicating different hours by means of the same horary apparatus, Mr. Anquetin will occupy a very prominent place. His first watch, called *Railroad*, was described in Vol. II., page 30, of the *Revue Chronométrique*, an illustration accompanying the description. Beside this, a favorable report of the Society of Watchmakers is to be found on page 62.

We refer to those two articles to show that of all the systems proposed, that of Mr. Anquetin is the only one showing exactly the hour and minute. But since Mr. Anquetin has finished his first conception, and there being at present such a great discussion about the universal hour, we have thought it proper to succinctly show the modifications introduced by him, their different purposes, etc.

We will in a few words explain the accompanying figure.

At the center of a dial, fixed in the usual manner, are located two movable circles (black ground); the larger one carries the minutes, the smaller the hours. These two movable circles stand between one another in a mechanical relation which permits them to turn in a certain proportion and in the progression permitted by the proportion of the hours to the minutes—that is to say, under the action of a button placed upon the pendant, the minute circle will make a whole turn while the hour circle makes only one-twelfth part of it. It is obvious that, the little black dial being able to turn either

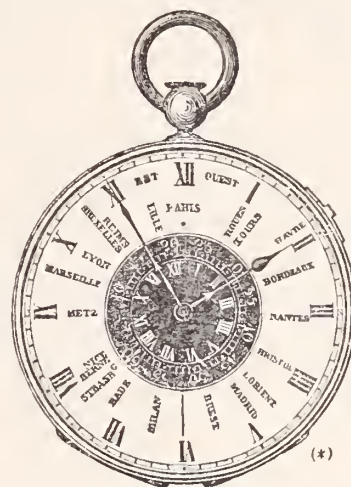

to the right or the left, one may give it an angular movement in its bearing to the hands and the large dial (white), so that the small dial indicates a different hour from that upon the stationary dial. Thus, for instance, one could ascertain at the same time the hour at Paris upon the large dial and that of another locality upon the small.

Mr. Anquetin gives the following details:

When used as a traveling watch.—In order to render plain the purposes of this dial, a red index is painted over the figure 60 of the movable minute circle; the names of the principal cities are inscribed within the free space between the two dials, at the places indicated by the difference of their meridian with that of Paris. It suffices to conduct this index against the indication of one of these cities, in order to have the time of that city place itself under the hands of the watch. You will therefore read the time of that locality upon the small dial; the hour underneath the hour hand and upon the movable lower circle; the figure of the minutes under the minute hand and upon the movable minute circle.

Example: In the above illustration the 60 index of the movable dial has been brought round opposite the word Strasburg; from this results that while the large stationary dial indicates the time of Paris, to wit, 1 o'clock 55 minutes, the small movable black dial points the time at Strasburg, 2 o'clock 17 minutes.

When used as counter.—Place the exact noon of the movable dial under the hands at the commencement of the observation; at the

end of it the hands mark the time elapsed upon the same small dial.

When used as reminder.—Place under the red arrow of the stationary dial the hours and minutes for your rendezvous; when consulting your watch to ascertain the hour of the day, you will be mechanically reminded of the hour or the meeting.

Fig. 1 represents the two dials; the movable dial *A* (hour and minute circles) is at the center of the dial. In the position represented in fig. 1 the hands point on the movable dial to 5 h. 19 m., while they at the same time point to 4 h. 7 m. upon the large dial *B*, which is the ordinary dial of the watch.

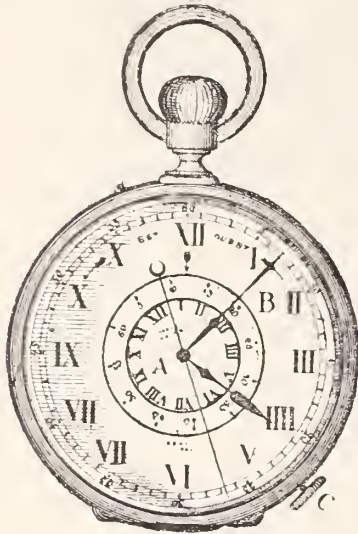

FIG. 1.

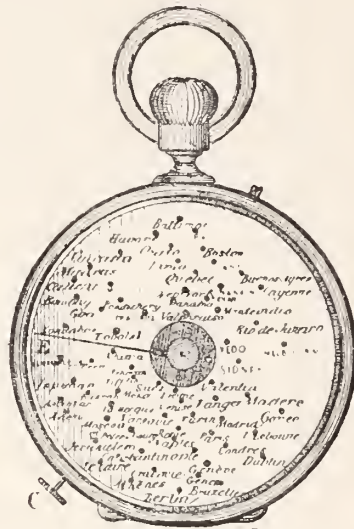

FIG. 2.

Fig. 2 shows the dome of the watch, lying underneath a beveled crystal. This dome is furnished with the principal cities of the world, over which rotates an index; it is enough, by means of the index button *C*, to place upon the point wanted the index *E*, which is pivoted at the center, for the movable dial *A* placed underneath this index to indicate the time of the place under question.

This operation completed and the index button having been returned to its place, the large dial will always give the time of the place where the observer is, while the other will indicate the time of the place singled out by the index. Again, the standard time may be changed on the large dial, and the time indicated upon the small dial will always be in correct proportion to the standard time as changed.

Cities which have the same time at night which we have in the day are inscribed in Roman letters; the others which correspond to us are in italics.

Fig. 3 shows the mechanism of the dial; fig. 4 that of the dome;

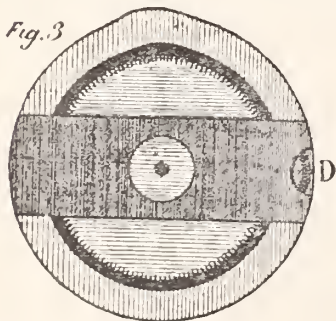

FIG. 3.

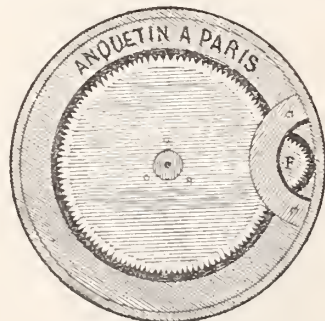

FIG. 4.

the wheels *D* and *F* are in communication by means of a crown wheel, which actuates the index button *C* (fig. 2), and which may be disengaged. It is readily seen that all this mechanism, not in any manner influencing the watch hands, but leaving them perfectly free, neither complicates nor surcharges in any manner the wheel work of this watch; and it is, therefore unreasonable to anticipate any complication or harm coming to the train of the universal watch.

Fig. 5 represents this watch: the names of the principal cities are inscribed upon the dial; a small gilt circle *L*, having indications of hours, halves and quarters is in bearing with the hour hand and

actuated by it. By figures inscribed upon this circle one may readily ascertain the time of the place.

Fig. 6 shows a watch with double concentric hour circles. The



FIG. 5.



FIG. 6.

hands are actuated by means of the drawn-out button *G*. This button having been restored into place, the hands will preserve their difference and correct proportion.

The Chain.

ALTHOUGH the English fusee watch with its chain is slowly disappearing, the American repairer will occasionally have one brought to him on which to exercise his ingenuity; the chain especially, being a very fragile piece, is liable to a number of accidents. While he may be fully conversant with every ailment likely to be met in anchor and cylinder watches, he may be nonplussed by those of a fusee, and consequently a few cursory directions may not be out of place.

To remedy a chain running flat or off the fusee.—If a chain runs flat on the barrel, or slips up the fusee, when winding, it must be carefully examined and the cause found out. The chain running flat on the barrel is generally caused by a faulty chain, though sometimes through the barrel being out of upright, and also if the chain is too wide for the spiral in the fusee. The chain should be examined to see that it goes into the groove in the fusee, and that it fills it entirely; then if the barrel and the axis of the fusee are both upright it is only necessary to stiffen the chain by hammering it along the rivets, and then, unless a very bad one, it will not turn over flat. It may result from the chain being too wide, then the remedy is a new chain. It may be found that the spiral projection on the fusee, which separates each turn of the chain from the next, has become bent or broken in places, so that the safe guidance of the chain cannot be relied on. If the damage is serious, the fusee should be re-cut; but if trifling, it may be rectified by carefully restoring the injured part as nearly as possible to its proper position. When the chain runs off without any apparent cause, it may frequently be remedied by changing it end for end, or by taking a very little off from the edge of the chain along its entire length.

To repair a chain.—A very frequent occurrence is the breaking of the chain, and to repair it neatly and strongly only a small amount of application is required. One end of the broken chain must consist of a double and the other end of a single link. Rest the broken chain upon a piece of hard wood, and with the edge of a sharp pen-knife slightly raise one end of the outside (double) link nearest the end of the chain, keeping the thumb nail of the left hand upon it in such a manner that only one rivet is loosened in the link. Turn the chain over and loosen the corresponding end of the opposite link in the same manner. Take the chain in one hand and the short broken link with a pair of pliers in the other, and give a sharp pull, when the piece will come out, leaving the little free ends of the link ready to receive the inside link of the other part of the chain. Take a piece of steel wire such as a sewing needle, tempered to a blue color, and taper it down with a smooth file until it passes through the holes in the links. Place the chain in position upon a piece of soft wood and join up with the pin. Press in quite tight, then with the nippers cut off as close as possible and file off the rough projecting ends with a very smooth file until nearly level with the chain. A few taps with a small round-faced hammer will complete the job.

Problems in the Detached Lever Escapement.

BY DETENT.

IT is not to be understood that a balance can not be so manipulated as to bring it to perform its proper functions when it is found to be faulty by the tests proposed in the last communication. As, for instance, after cutting the balance and truing it, we place it on the poising tool and bring it to poise in a temperature of say 60° F. If on raising the temperature to 98° F, we find the balance to be out of poise, the indications are the relative thickness of the composite metals composing the rim are not preserved, and the first thing to do is to examine the segments to determine if sight will not locate the fault. If such careful inspection with a high magnifying power will not reveal the location of the error, it will, in the majority of instances, be safe to make an effort to compel the segments to deflect alike. In carrying out such a determination we should be sustained by good judgment, based on experience. Let us reflect a moment on the situation, or, in other words, study the problem. What is the cause, say we to ourselves, of our balance becoming out of poise on raising the temperature? The answer is plain enough, one of the segments deflects by the increase of temperature more than the other. A very profitable (as far as experience goes,) series of experiments can be made by taking two or three old expansion balances and testing them for poise in temperature. We find one of the segments to be more susceptible to the effects of heat than the other. In seeking to remedy such defects it is easier to increase the activity of a dormant segment than to prevent the active one from deflecting too much. A segment can be made to deflect more by making it thinner near the arm. Generally a slight reduction in the thickness of the brass part of the rim will effect the desired result. It is unsafe to make any decided reduction in the thickness, as it would be attended with an untold number of complications. As a rule, however, thinning of a segment influences it more in cold than heat; consequently, a movement which was apparently perfectly adjusted to temperature, when laying flat, that is, dial up or dial down, would, when run through position adjustments from this cause, be affected as if one of the quarter screws were turned. It is well to bear in mind a poising tool is only a close approximation to anything like perfection. Let any person so disposed select a fine movement for a few experiments. To illustrate we will lay aside the strict consideration of heat and cold adjustments and try one or two in position. We will suppose our movement is gaining three and one-half seconds a day with the stem up, and the balance appears to be perfectly in poise; we now change the relative positions of the balance spring stud and roller so that the balance is revolved one-fourth of a revolution on its axis, and we will now find the rate of our watch changed. This may arise from a host of causes—from the balance not being perfectly poised, or the cause may be the pivots are not perfectly round or the jewels ditto; at any rate it is a very severe test and one to which every closely adjusted watch should be subjected. If the balance will not stand the poising tool test of temperature after it has been "manipulated" reject it, and try another. The greatest aggregation of weight in a balance rim should be about two-thirds of the distance from the arm to the cut end of the segment. Of course, the thickness of the rim (by thickness, I mean measuring radially), will affect the best relative position for "bunching" the screws. Thin deep segments would perform better with the aggregation nearer the arms. About three screws should usually be placed as close together as the holes in the rim will permit.

More than sixteen, or less than twelve screws in the two segments should, as a rule, be avoided. A balance should be trued in the round in a room where the temperature is from 75° to 80° F.

For all temperature adjustments it is not important to have any very elaborate appliances, either in the way of an "oven" or "refrigerator." In my next communication I will describe a very simple and complete outfit for adjusting and temperature. When I started

the theme of adjustments, I only proposed to consider the subject as relating to the lever escapement, but have since concluded to give it a broader and more comprehensive treatment, and while I do not propose to write an essay on adjustments in general, I propose to consider more in detail the relation of the detached lever escapement to the balance spring. Many workmen will attempt adjustments when the condition of the balance spring is such that it is simply nonsense to attempt anything of the kind. A balance spring should be true in the flat and true in the round; should have not less than ten or more than fifteen coils. The point where the inner end of the spring pins into the collet should stand opposite to the regulator pins when the regulator is in the middle of its arc, and the balance at rest. The watch should be brought to time by means of the screws; changing, taking out or adding, until the watch is running correctly with the regulator in the middle of its arc.

A very good test of a balance spring being true in the round is to notice if the third and fourth coils (counting inward from the stud) seem to stand still when the balance has a good motion. It is usual with adjusters to attend to heat and cold adjustments, and make no attempt at isochronal or position. This is well enough in factory methods, but to the watch repairer an approximation to isochronal adjustment is of quite as much, if not more, importance. A good practical way of getting at an approximate isochronal adjustment is to keep four main springs for eighteen size American movements, two weak springs, one with a T end, and one with a side brace; two strong springs, one with T end and one with side brace. After putting the escapement in as good order as possible and testing it by letting it run on half time, that is, without the balance spring. Put the weak spring in the barrel and wind it two full turns. The balance should now make about three-quarters of a revolution. Set your movement carefully with a good regulator and compare every six hours. Wind your movement half a turn every three hours. Note the rate of the watch carefully for twelve hours. Then change the weak main spring for a strong one. The balance should now make a revolution and a-half. Again make careful comparison with your regulator to ascertain whether the watch gains or loses in the long vibrations. How to equalize the long and short vibrations or "isochrize" one balance spring will be the theme for our next interview.

The "Safest" Watch.

IT is a well-known fact that the mainspring of watches break, no matter how carefully they are selected. Over-winding, change of temperature, and other causes will conduce to this. The force of the recoil of a broken spring is very great, and when we consider that many parts of a watch, such as pivots, etc., are nearly as fine as a hair, it is not surprising that this sudden recoil will often cause dam-

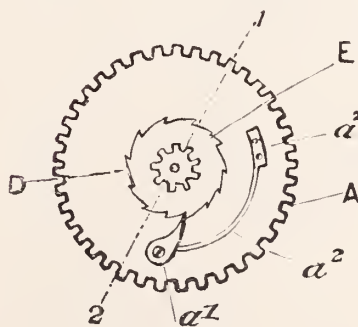

FIG. 1.

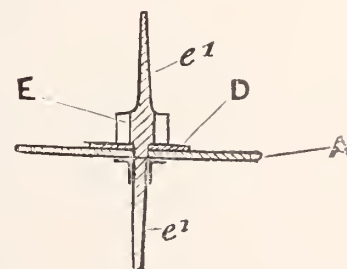

FIG. 2.

age (costly to repair) both to the pivots and to the teeth of wheels, the latter being frequently broken. To remedy this defect Alex. Edwards & Co., Coventry, Eng., have introduced in their "Safest" watch, an improvement, the nature of which will be understood from the accompanying illustrations. Fig. 1, shows a center wheel A with

the various parts connected therewith ; and Fig. 2, is a sectional elevation on the line 1, 2, of the wheel A, with its arbor $\epsilon 1$.

The center pinion E, usually forms part of the center wheel A. It is evident that if the spring breaks, and supposing the center wheel A and pinion E to be fast together as is ordinarily the case, the whole power will be transmitted through this wheel to the various trains of wheels with which it is geared until the momentum has been exhausted. In this instance this transmission is prevented by mounting upon the arbor $\epsilon 1$ (Fig. 2) the pinion E and ratchet D so as to run loosely when necessary without the arbor $\epsilon 1$ turning, but when the watch is working in the ordinary way, the ratchet $\epsilon 1$, which is held in its position by the spring $\epsilon 2$ carries round the centre wheel A, but immediately the spring breaks, the ratchet D and pinion E simply revolve upon the arbor loosely without having any effect upon the other parts of the watch.

It will thus be seen that this simple device adds no complication to the mechanism and yet is effective, and also that there can be no danger of its ever getting out of order.

Improvement in Complicated Watches.

CHARLES H. MEYLAN, of the firm of Mathey Bros., Mathez & Co., manufacturers of complicated watches, 16 Maiden Lane, New York, was on Sept. 3, awarded letters patent on a double watch barrel which contains several important improvements over the device at present used in complicated watches. Mr. Meylan is an expert horologist, and has the management of the firm's factory at Brassus, Switzerland.

Heretofore, in watches containing two trains of gearing, for independent $\frac{1}{4}$ or 1-5 seconds in stop-watches, or for striking time in repeating watches, two spring barrels have been made use of, one spring barrel giving motion to the main train or time gearing, while the other giving motion to the independent seconds-hand or to the striking devices. These barrels have been, however, upon separate arbors and have occupied considerable space in

the watch; and the devices that communicated motion from one spring barrel to the other, whereby only one movement was necessary in winding, have been complicated.

The object of this new improvement of Mr. Meylan's is for simplifying the construction and lessening the cost of manufacture and

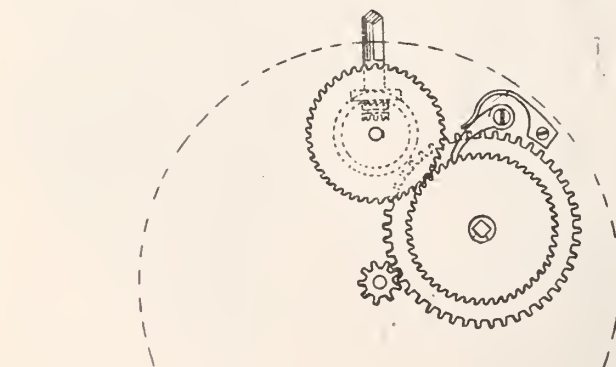

FIG. 2.

for lessening the space occupied by the two spring barrels. In this inventor's device, the two springs and the two spring barrels are placed on one arbor, and in consequence of the second spring having comparatively little work to perform, it can be made quite narrow; hence the space occupied by the two spring barrels on one arbor is but slightly increased, while the space occupied by the second arbor spring and barrel, in the old arrangement, is totally saved, and the

inventor takes the movement for one train of gearing from a wheel around the edge of each spring barrel.

The reader, if he be at all versed in watch making, will, by examining the diagrams, readily understand the construction of the mechanism, and will appreciate the great advantage that its use will secure in the manufacture of independent split $\frac{1}{4}$ and 1-5 seconds and repeaters—less room, less friction, less cost. Fig. 1 is an elevation illustrating the connections to the winding mechanism and showing the relative positions of the two spring barrels;

Fig. 2 is a plan view of the mainspring barrel and winding gearing; Fig. 3 is a section in larger size of the spring barrels; and Fig. 4 is a plan view of the secondary spring barrel and its spring.

In many instances, as is known, the springs barrels are provided with a stop mechanism to limit the number of turns in winding up the spring while in others this stop device is not employed. Mr. Meylan's invention may be used with or without such device.

Mr. Meylan has assigned the right of the patent to the firm of which he is a member. The conception of this device is in line with the policy of this firm of expert mechanics, who have so much advanced the manufacture of that important branch of horology—complicated watches—and to whose labors all credit is due.



President, HENRY HAYES.....Of The Brooklyn Watch Case Co.
 First Vice-President, JAMES P. SNOW.....Of G. & S. Owen & Co.
 Second Vice-President, ROBERT A. JOHNSON.....Of Celluloid Enamel Co
 Third Vice-President, JOSEPH B. BOWDEN.....Of J. B. Bowden & Co.
 Fourth Vice-President, CHARLES G. LEWIS.....Of Randel, Baremore & Billings.
 Secretary and Treasurer, WILLIAM L. SEXTON.....Of Sexton Bros. & Washburn.

EXECUTIVE COMMITTEE.

GEO. H. HOUGHTON.....With Gorham Mfg. Co.
 WM. H. JENKS.....With Tiffany & Co.
 A. A. JEANNOT.....Of Jeannot & Shiebler.
 GEORGE R. HOWE.....Of Carter, Sloan & Co.
 WM. BARDEL.....Of Heller & Bardel.
 J. R. GREASON.....Of J. R. Greason & Co.

There were present at the regular monthly meeting of the Executive Committee, held on Friday, Sept. 6th, Vice-Presidents Lewis and Bowden and Messrs. Howe, Greason and Sexton.

There were five changes of beneficiaries granted, and the following applicants were admitted to membership: Augustus P. Craft, Indianapolis, Ind., proposed by Ira E. Pee; Emil Crecelius, Providence, R. I., proposed by S. C. Howard; Jeremiah Hillman, New York City, proposed by G. Courvoisier; Victor L. Roessel, St. Louis, Mo., proposed by N. W. Phelps; R. F. Rupprecht, New York City, proposed by D. F. Foley; Geo. W. Smith, New York City, proposed by A. K. Sloan; Oscar Yost, Shenandoah, Pa., proposed by Rodney Pierce.

The next meeting of the Executive Committee will be held on Friday, Oct. 4th, 1889.



The following list of patents is compiled from the records of the United States Patent Office, and specially reported to THE JEWELERS' CIRCULAR.

Issue of August 27, 1889.

Design Patents Nos. 19,284 and 19,285—SPOON, FORK, ETC. GEORGE H. BALCH, Newburyport, Mass., assignor to The Towle Manufacturing Company, same place. Applications filed July 15, 1889. Serial Nos. 317,644 and 317,645. Term of patents 7 years.

Design Patent No. 19,287—HANDLE FOR SPOONS, ETC. LOUIS R. HORTON, Providence, R. I., assignor to Joseph B. Knowles and Stephen M. Knowles, both of same place. Application filed August 5, 1889. Serial No. 319,838. Term of patent 7 years.

409,668—PURIFYING ALUMINIUM CHLORIDES. HAMILTON Y. CASTNER, London, England. Filed March 19, 1889. Serial No. 303,901. (No specimens.) This process of purifying anhydrous chlorides of aluminium consists in melting the chlorides with a suitable quantity of a metal, as aluminium or sodium, adapted to reduce the contained iron to a metallic state, and then separating it.

407,905—CLOCK PENDULUM. GEORGE P. REED, Melrose, Mass. Filed June 30, 1888. Serial No. 273,713. (No model.) In a clock pendulum, the combination of a rod provided with a ball, a laminar ring comprising plates of different contractile and expansive capacity, the ring being secured to the ball and cut or opened at a point opposite its attaching point to form free ends, and the adjustable weights on the ends.

409,745—WATCH CASE SPRING. HARRY R. GAUL, Philadelphia, Pa., assignor to the Keystone Watch Company, same place. Filed April 2, 1889. Serial No. 305,752. (No model.) A watch case spring formed of stamped sheet metal, with free ends bent outwardly, and having a slit or slip at its middle part to make that of less width than the end parts and a part projecting from said middle part to act on the lid.

409,755—WATCH CASE SPRING. JAMES D. EWING, Philadelphia, Pa., assignor to the Keystone Watch Case Company, same place. Filed March 21, 1889. Serial No. 304,170. (No model.) A watch case spring formed of stamped sheet spring metal and curved to form a segment of a circle and to conform to the curvature of the groove of the case center, and having a slit by which a portion of its middle is reduced in width, and an upwardly and outwardly extending projection from the narrowed portion which points away from the inner curve of the spring, in combination with a watch case center having an inner granular groove, in which the spring is received and held by its elasticity.

409,789—HAIRSPRING STUD FOR WATCHES. STEPHEN JENKINS, New York, N. Y. Filed June 8, 1888. Serial No. 276,463. (No model.) This fastening for the springs of clock movements consists in the combination, with the back plate having the post secured rigidly thereto, of the stud having rotary bearings in the back plate and formed with the clamping head projecting to one side and at sufficient distance from the back plate to impart elasticity to the clamping fastening, whereby the free end of the spring is clamped between the post and head by a turning movement of the stud, and is held with a yielding pressure.

409,927—OPERA OR FIELD GLASS. ABNER B. CLEMENTS, U. S. Navy, assignor to Levy, Dreyfus & Co., New York, N. Y. Filed March 30, 1889. Serial No. 305,479. (No model.) As a new article of manufacture, an opera or field glass consisting of two barrels, folding frame and extension tubes, each having an independently-adjustable lens-carrying disk, pivoted eccentrically with relation to the eye aperture and projecting laterally beyond the cap of the extension tube, a series of numbers or symbols on the disk corresponding to the eye lenses, an opening in the cap of the extension tube through which the numbers are displayed, and a detent for maintaining the disk in position.

410,013—ELECTRIC PENDULUM CLOCK. ALBERT L. PARCELE, New York, N. Y. Filed April 27, 1888. Renewed July 18, 1889. Serial No. 317,858. (No model.) The combination of the pendulum, the switch operated thereby and carrying adjustable screws embracing the pendulum, the pivoted brush, its pivoted supporting block, and the adjusting screw for rocking the block.

410,233—EYE-GLASSES. JOHN L. BORSCH, Philadelphia, Pa. Filed Mar. 23, 1889. Serial No. 304,482. (No model.) These eyeglasses have duplex nose-pieces attached to a carrier having a central connection with the eyeglasses and adjustable at right angles to the lenses.

410,234—SPECTACLE CASE. WILLIAM W. BRILHART, Indiana, Pa. Filed Dec. 3, 1888. Serial No. 292,479. (No model.) In this spectacle-case, the shell has longitudinal swell portions at the sides thereof, and a longitudinal partition having the soft lining and having the extended end.

Issue of September 3d, 1889.

410,272—MANUFACTURE OF PENS. JOHN T. FOSTER, Arlington, N. J. Filed Mar. 7, 1889. Serial No. 302,312. (No model.) This improvement in the art of making pens consists in roughening the nib portion of the blank by striking it with a punch having its surface formed with projections, whereby corresponding indentations are formed in the blank, thereby compressing the metal, imparting elasticity to the pen, and avoiding the necessity of the process of nibbing or stoning.

410,274—CALIPERS AND DIVIDERS. WALTER GLITSCH, Geneva, Switzerland. Filed March 14, 1889. Serial No. 303,357. (No model.) Patented in Belgium August 24, 1888, No. 82,998. In this tool is combined, with the bars pivoted together, two pairs of legs pivoted to the outer ends of the bars, one pair of the legs having permanent lateral projections and sockets with points or lateral projections and adapted to fit upon the ends of the other pair of legs.

410,327—WATCH BARREL. CHARLES H. MEYLAN, New York, N. Y., assignor to Mathey Bros., Mathez & Co., same place. Filed June 8, 1889. Serial No. 313,545. (No model.) The combination, with the winding arbor, mainspring and spring barrel around such arbor, of a secondary spring and spring barrel also around the arbor, a wheel having a central opening setting over the square end of the arbor, and a circular hub entering a hole in the watch plate or bridge, and a pawl for holding such wheel.

410,558—PINION HOLDER FOR PINION-POLISHING MACHINES. GRANVILLE NUTTING, Waltham, Mass., assignor to the United States Watch Company, same place. Filed April 29, 1889. Serial No. 309,091. (No model.) This holder for pinions for leaves of pinions to be polished is composed of a block to hold and support the pinion at and with a portion of its perimeter exposed, and heads on opposite sides of the pinion-holding block, and each carried by and adjustable on separate blocks, in combination with a guideway, having the several blocks held thereon.

Issue of September 10, 1889.

Design Patent No. 19,301—SPOON, FORK, ETC. JOHN H. ARGVILL, Newburyport, Mass., assignor to The Towle Manufacturing Company, same place. Application filed July 15, 1889. Serial No. 317,643. Term of patent 7 years.

410,574—PROCESS OF OBTAINING ALLOYS OF ALUMINIUM. LEON Q. BRIN, Paris, France. Filed Jan. 24, 1889. Serial No. 297,440. (No model.) Patented in France March 6, 1888, No. 189,171, and in Belgium March 7, 1888, No. 80,909. This process of producing alloys of aluminium with copper or other metal in the immediate presence of ignited fuel consists in placing the metal (copper, etc.) and a mixture of flux containing aluminous clay or aluminous salt or earth and common salt (or other suitable chloride) upon and in direct contact with a bed of fuel, and in then igniting the fuel and subjecting the metal and mixture to a melting heat in the immediate presence of the burning fuel, thereby effecting the reduction of aluminium and alloying it directly with the metal.

410,808—PICTURE-HOLDER ATTACHMENT FOR WATCH CASES. GASPARD SCHELKER, Brooklyn, N. Y., assignor of one-half to Henry Goll, same place. Filed May 24, 1889. Serial No. 311,937. (No model.) This device consists of one of the outer lids or covers of a watch case having a circular offset and a concentrically arranged series of picture receiving recesses, of a bezel sprung upon this offset, and the revoluble disk resting over the recessed face of the lid or cover, under the bezel, and having an aperture and a pin or projection.

410,825—CLOCK CASE. JOHN M. DURWARD, Bristol, Conn., assignor to the Bristol Clock Case Company, same place. Filed Dec. 27, 1888. Serial No. 294,779. (No model.) A stone clock case having two of its parts each provided with intersecting vertical and horizontal pockets arranged so that when the parts are properly assembled their corresponding horizontal pockets will communicate, so as to permit the formation of a key, binding the two parts together, by pouring metal into the vertical pockets of one of them.

410,831—WATCH-PENDANT WINDING AND SETTING DEVICE. WILLIAM T. GRAESSLE, Philadelphia, Pa. Filed April 20, 1889. Serial No. 307,977. (No model.) In this winding and setting mechanism, there are two springs having overlapping ends, a stem passing through a slot in one spring and being provided with collars on opposite sides of the springs, the other spring having beveled faces, and the first spring having a lip adapted to engage the beveled faces.

410,945—WATCH CASE. WILLIAM C. TAFT and PAUL J. MORAND, Chicago, Ill.; said MORAND assignor to said Taft. Filed April 24, 1889. Serial No. 308,404. (No model.) A watch case in which are combined an integral center and back, a movement ring that is adapted to fit into this center, a spring latch which operates to lock the ring in place, and a glass bezel that engages with the outer portion of the ring.

Issue of September 17, 1889.

411,138—ELECTRIC CLOCK SYSTEM. CHARLES H. CARTER, Brooklyn, N. Y. Filed December 27, 1888. Serial No. 294,815. (No model.)

411,146—STEM WINDING AND SETTING WATCH. OSCAR F. GUNZ, Rutherford, N. J. Filed March 30, 1889. Serial No. 305,452. (No model.) In this invention is combined with an oscillating yoke carrying wheels for engagement with the spring barrel wheel and the hands-setting wheels, of a tubular pinion engaged with the central wheel of the yoke, a sliding stem or push pin in the tubular pinion and provided with an annular groove, a cam pivoted to act on one end of the yoke and provided with a pin or lateral projection passing through a slot in the main plate, a pivoted lever engaging at one end this pin or projection of the cam and at the opposite end entering the annular groove in the stem or push pin, and a single spring acting on the yoke and tending to engage with a wheel on the same with the spring barrel wheel of the watch.

411,147—STEM WINDING AND SETTING WATCH. OSCAR F. GUNZ, Rutherford, N. J. Filed May 9, 1889. Serial No. 310,120. (No model.)

411,148—REPEATING WATCH. EDOUARD HEUER, Bienne, Switzerland. Filed February 6, 1889. Serial No. 298,828. (No model.) Patented in France October 17, 1885, No. 192,640; in England November 14, 1888, No. 16,519, and in Switzerland November 15, 1888, No. 9.

411,164—NOSE PAD FOR EYE-GLASSES. JOHN P. MOLITOR, Vallejo, Cal. Filed January 28, 1889. Serial No. 297,823. (No model.)

411,168—GONG STRIKING MECHANISM FOR SYNCHRONIZED CLOCKS. CHESTER H. POND, Chicago, Ill., assignor to the Self-Winding Clock Company, New York, N. Y. Filed May 3, 1889. Serial No. 309,430. (No model.) In this mechanism there is combined with a clock train, a synchronizing mechanism, and an electro-magnet and armature for operating the same, of a gong, a spring-retracted hammer, and a rod independent of the clock mechanism, and extending from the hammer into the path of the armature; also the electro-magnet, its armature, the synchronizing device, as described, operated by the armature, the gong and the striking device therefor, consisting of the rod, the pivoted lever carrying the hammer and the spring.



* A Complete History of Watch and Clock Making in America.

[By CHAS. S. CROSSMAN.]

Number Thirty-Eight.

Continued from page 82, September, 1889.

WATCH CASE MAKING.

LADD WATCH CASE CO.

Work upon the tools for the Ladd patent watch cases was commenced in 1865, and the first cases were made in 1867, a patent having been issued to Geo. W. Ladd in June of that year. This case was such a novelty that it was a success from the start, and became a great favorite with the trade throughout the United States and British Provinces. Later, when flat cases were in great demand an improvement was made on them by Mr. Ladd, consisting of a ring of solid gold which was soldered on to the edge of the cover, where the heaviest wear came, for which a patent was issued to him in 1879.

As much objection was found to the exposed surface of base metal caused by the cut for the joints, Geo. S. Ladd, a nephew of Geo. W. Ladd, invented a method for covering these with a plate of solid gold which was soldered on, thus meeting this serious objection and making a perfect filled case without a flaw, for which a patent was issued in 1883.

In the year 1883, too, the Ladd Watch Case Co. was incorporated by the legislature of Rhode Island, and bought the plant, business and patents, of J. A. Brown & Co., who had heretofore manufactured and sold the Ladd cases.

The new company commenced to improve the shape of the case, and finally perfected what they designated as their Acme shape. A patent was applied for and issued by the Patent Office in June, 1885, and it is a leading style to-day for watch cases throughout the country.

The factory of the Ladd Watch Case Co. is at Nos. 104, 106 and 108 Eddy street, Providence, R. I. It is fully equipped with special machinery and tools, furnishing employment to many hands, while the trade of the company, which is supplied from the salesroom and offices at No. 11 Maiden Lane, New York, extends throughout the United States and the Canadas.

S. ANDERSEN,

Of Chicago, made cases in limited quantities from 1857 to 1860, employing altogether not more than five or six men. Afterwards when the firm was changed to Juergens & Andersen, from 1860 to 1871, about five men were employed. Mr. Juergens, of the firm, was instrumental in organizing the Blauer Watch Case Co. into a stock company at the death of Mr. Blauer.

S. COHEN & CO. AND THE CHICAGO WATCH CASE CO.

This firm, which was composed of Sol. Cohen, Martin Fisher and Louis Sanders, started in business in April, 1881, at 99 Madison

street, Chicago. In January, 1882, Geo. Piper and Leonard Strobel came in and they formed the Chicago Watch Case Co. Shortly after this they moved to their present location.

THE DUEBER WATCH CASE MFG. CO.

John C. Dueber, the founder of the Dueber case works, is a native of Prussia, whence he came to this country in 1850 at the age of nine years. When he was eleven years old his father died and he had to go to work to make a living for himself and his mother and sister. He began wrapping candies in a candy manufactory, but after a year or two concluded that was too slow for him, and apprenticed himself to Frank Doll, the earliest watch casemaker in Cincinnati, the agreement being that he should receive \$2 per week the first year, \$3 the second, \$3.50 the third and \$4 the fourth. He remained there till he was about 20 years old. Doll was content to make a few cases a week, but his young workman was quick to see the possibilities of a great development of the watch case business, and when he was about 20 years old he started in business for himself, his great desire at that time being to make provision for his mother and sister who were dependent upon him for support. He had saved about \$400, and when his little plant was established at Cincinnati he had about \$35 left as a working capital. Mr. Dueber began his business by himself, and as it was a success from the start he added one employee after another, personally selected workmen, and trained his own help, adding machinery all the time. This machinery was most of it made on the premises, as up to that time all watch cases had been made by hand and no special tools could be purchased. Mr. Dueber invented many of the tools and superintended the making of the machinery.

He made good cases and the young manufacturer and his product found favor with the trade rapidly. Ten years ago his business had increased to such an extent that he built a large factory at Newport, Ky, and from that time till the present the growth of his business has been almost phenomenal. In July, 1889, the factory was removed to Canton, O., where large donations of land and money had been given and spacious buildings erected.

The present works are located in a fine building nearly 600 feet long, and situated on a commanding eminence. They have facilities for turning out a very large production, their manufacture embracing a full line of cases, both gold, silver and filled, for the regular market.

FRANK DOLL

Began business in Cincinnati in 1857. His was the first watch case factory started in the West. He was located in the Carlisle Building, corner of 4th and Walnut streets, prior to his selling out to Duhme & Co. His business was the casing of Swiss and English movements and general repairing. He did a business of about \$50,000 in the year 1872, the last year he manufactured, prior to selling out to Duhme & Co.

DUHME & CO.

This well-known Cincinnati house began the manufacture of gold and silver cases in 1871, and in the following year purchased the business of Frank Doll, who was then on the corner of 4th and Walnut streets. They employ about 65 men and turn out about 5,000 cases a year, principally fine cases, of which they make a specialty. The factory is in the same building as their store, on the corner of 4th and Walnut streets. Herman Duhme, Sr., the founder of the house, died in 1887, and the remaining partners, Robert H. Galbreath, Frank and Chas. H. Duhme, continue the business. This house is entering on the second half century of its existence.

LOUIS LACHAT.

Louis Lachat commenced the business of watch case making in Chicago in 1877, at 70 La Salle street. He remained there until 1881, when he removed to Kansas City for a short time. He returned to Chicago the same year and started on Clark street in 1882. He went to Europe and, returning to America, settled in Louisville, Ky., where he carried on case making in a small way. In Chicago he turned out from forty to fifty gold cases a week. He was succeeded by the Chicago Watch Case Manufacturing Co.

THE CORNELL & CALIFORNIA WATCH COMPANIES AS WATCH CASE MANUFACTURERS.

After the Cornell Watch Company had located in San Francisco in 1875, they conceived the idea of making cases, both gold and silver, and engaged the services of Mr. Sperry, formerly of the firm of Blauer & Sperry, of Chicago, to take charge of that branch of the business. The company had got the case-making part of the business started, and were turning out about ten cases a day at the time of their failure. The California Company resumed the manufacture of cases under the new name early in 1876, but owing to the difficulties that arose in the company, as already detailed in the Cornell & California Company's history, no great progress was ever made, and the product probably never exceeded a dozen cases per day for any great length of time. The bulk of the production was silver cases, but some gold ones were made. At the time the company closed up its affairs the unfinished silver cases and the stock on hand was taken to the mint, where it was coined into trade dollars, then the prevailing standard of silver coin on the Pacific Coast. This was thought to be the easiest and quickest way of turning the silver into money. This may seem a strange method, but in San Francisco it was the prevailing custom for dealers and manufacturers to bring their old gold and silver to the mint and have it made into coin.

BLAUER & SPERRY—THE BLAUER WATCH CASE COMPANY.

Blauer & Sperry started at the corner of LaSalle and Anderson streets, Chicago, about 1869. Mr. Blauer, the senior partner, was born in the Canton of Berne, Switzerland, and at an early age was apprenticed to the trade of watch case spring making. He came to America at 21 years of age, and soon settled in Wisconsin. Mr. Sperry, of the firm, went to Cincinnati later, but subsequently returned to Chicago and entered the employ of Juergens & Anderson in 1868. The firm was located at No. 159 Lake street at the time of the fire, and afterwards started at 468 Washington avenue, thence removing to 182 State street, where they stayed about one year. In 1883 Sperry & Blauer dissolved partnership, and Mr. Blauer dying shortly after, the Blauer Watch Case Company was formed, with officers as follows: Paul Juergens, President; Chas. Blauer, Vice-President; Herman Nether, Secretary and Treasurer; Amelia Blauer and Wm. Taft constituting the company.

THE NORTHWESTERN WATCH CASE COMPANY,

Was organized about 1878, at Rockford, Ill. It had for its first president, H. W. Price; its first secretary, Paul Mockerhaupt, and its superintendent, Edward Muckle. They bought the tools of a defunct company of the same name in Chicago, and were the direct successors of Muckle, Tunking & Smith. They put on the market the patent climax case and made quite an extensive line of silver cases. The first year there was a deficit of about \$12,000. An effort was then made to increase the capital stock, but for some time it could not be done. In June, 1883, however, it was increased \$20,000, and the deficit made up. At this time the services of Mr. Tichnor were secured as secretary. Mr. Tichnor had been an express agent for many years in Rockford, and enjoyed the confidence of the stockholders. At the last annual meeting he was made president, Mr. Price, the great glove maker stepping out. Those who originally subscribed to the stock were made to think the concern would be a success if brought to Rockford, as the cases could be sold in connection with Rockford watches. The cases were poor at first, but the standard of workmanship has been raised since. The name of the company was changed in 1883, to the Rockford Watch Case Company.

(To be continued.)



Proceedings of the Watchmakers' and Jewelers' Union.

First Meeting.—Reported by the Secretary.

ANNOUNCEMENT.

FOR a long time there has been felt the need of some central organization or rallying point for the advanced thinkers of the trade, who wish to lay their ideas before their brethren, and have them intelligently and appreciatively considered and discussed.

There are also many workmen who would like to be informed upon technical points which are obscure, at least to them, and who at present have no other resource but to write to the editor of THE JEWELERS' CIRCULAR for the required instruction. So many such letters have been received that the editor has very kindly offered to allow a reasonable amount of space in its pages, each month, for the publication of the proceedings of a representative body of the trade on the condition that they receive and answer such inquiries.

The result is the formation of "The Watchmakers' and Jewelers' Union," which includes among its members watchmakers, clockmakers, jewelers and manufacturers, dealers and salesmen in all the various crafts comprised in the popular title of "jewelers," who are gentlemen of standing and well informed in their respective lines of business.

In order that they feel free to express their disinterested and candid opinion on all subjects brought before them, without any fear of unpleasant business complications on account of their remarks, which might sometimes arise if the parties were customers of theirs, it has been thought proper to assign to each member a fictitious name to be used in the published proceedings.

For the same reasons, we are obliged to limit the attendance at our meetings to the members exclusively, and we cannot answer any inquiries as to who such and such a member is, and the like. But all are invited to attend by letter, and we promise them careful and honest criticism of all papers sent in to us for that purpose.

We wish it understood that this invitation is not limited to horological subjects, but extends to all related matters, and not merely to their technical, but also to their commercial, artistic and theoretical aspects. Manufacturing, repairing, arranging, showing and selling are all worthy of attention, and all afford good fields for new and improved methods. Give us your original ideas on these subjects.

The trade is what we make it; let us make it what it should be.

TO THE ADVANCED THINKERS OF THE TRADE.

To those who are not content to rub along in the time worn ruts of superstition and custom, but can strike out new paths and ideas worthy of general attention, we offer a medium through which you can lay your discoveries and views before the trade. We will be pleased to hear from you at any time, and to discuss your propositions. You may be assured that they will be understood and appreciated here, and we shall endeavor to present them acceptably to our readers. We are in sympathy with every effort to improve or educate the trade, and it will receive our hearty commendation and support.

Write as briefly as possible, for our space is limited—so limited that no personalities can be published. Letters which are too lengthy or not suitable for publication in our proceedings, will be

sent to the editor of THE CIRCULAR, and if accepted by him, will be inserted as communications or articles.

TO THE TRADE AT LARGE.

If you have special and exclusive information on any point, are better posted than your brethren, write out a description and send to us. If every man who has an improved tool or attachment, or way of doing some job, would describe it in our columns, each one would receive back many times more than he gave, and the whole craft would be benefitted. Let us hear from you. We intend to be a live organization, and we want you to furnish some of the life.

Inquirers who wish for technical information on any subject properly within the purview of our body, should write their questions clearly and concisely, and send them in to be discussed and answered in our proceedings. If none of the members in attendance can give the desired information, we can doubtless obtain it from outside sources by printing the letter and laying it before the trade, and we will gladly be of service to our brethren in any way, as a focus for obtaining and disseminating valuable information.

NOTICE TO CORRESPONDENTS.

Communications should be written as briefly as possible consistently with clearness, on only one side of the paper, and should be received here by the 10th day of the month, in order to be discussed at our meeting for that month and inserted in the next issue of THE CIRCULAR. Write them separately from any business matters, and address them to "SECRETARY OF W. & J. U., care of THE JEWELERS' CIRCULAR, 189 Broadway, New York.

Illustrations.—If you send drawings which are properly finished and suitable to be photographed for printing, engravings will be made and inserted with the letters when the subject is of sufficient interest to warrant it. But we cannot undertake to remodel and correct them, nor to make new drawings. They should be made correctly, precisely as they are to be printed, on clear, white paper, with jet black ink.

If the device described has been patented, a copy of the patent can be sent to us, and we can probably select a suitable figure and have a cut made directly from the patent drawings, as they are executed with special reference to being photographed, and may serve as models for our correspondents to follow. These cuts will be made without expense to our correspondents. Diagrams and drawings, showing mechanical arrangements, are preferred to perspective and ornamental views, as our object is instruction, not amusement.

Should our correspondents wish more numerous and costly engravings than are contemplated for our proceedings, we would refer them to the editor of THE JEWELERS' CIRCULAR. He has authorized us to say that if the subject matter is of general interest to his readers, he will have engravings made (and the drawings also, if necessary), and insert them, with a suitable description of the device, as an illustrated article, at no expense to the correspondent except the actual cost of the drawings and engravings. After publication, the engravings will be sent to him, if he wants them. Approximate estimates of the cost can generally be made in advance if the correspondent describes precisely what he wants.

DISCUSSION.

After the formal organization of "The Watchmakers' and Jewelers' Union" had been completed, the officers took their places, and the following papers, received from the editor of THE JEWELERS' CIRCULAR, were then discussed:

"CLEANING ELECTRICITY OUT OF WATCHES."

To the Editor of the Jewelers' Circular:

I suppose you are willing to print a good thing for the fraternity, so I send you an account of a valuable discovery I have made about watches, to put in your paper. I have found out what the trouble is with so many watches that we put in first-class order, but still they won't keep time. They are charged with electricity,

and, of course, they cannot run well till that is cleaned out of them. The way I discovered it was this:

There is one other watchmaker in our town, up at the Post Office. He is one of the high-toned sort, has electric lights, dynamos, magnetizing machines, gilt-edged spittoons, and all the modern improvements, including a city watchmaker, and yet his watches will not keep time, and his customers have to bring them to me to get them fixed over.

I suspected that some of the electricity might have got into the watches, and as I had a horseshoe magnet a foot long I tried them with it. Sure enough, as soon as I brought my magnet near them they would begin to cut up all sorts of capers, showing that they were chuck full of electricity.

Sometimes one of my watches would make trouble, too. Then I would ask the owner if he had been near the other jeweler's store, and he would own up that he had. Then I would say to him: "That is just what ails it. That fellow's store is just saturated with electricity and it gets all over everything that comes near it. You ought to leave your watch at home when you go up there unless you want it ruined. I don't warrant it against electricity."

Well, of course, the watches have to be cleaned out and the kinks got out of them. Sometimes the customers kick a little about that when they have just had them cleaned and fixed up, but I say to them: "It has got to be done. This magnet shows that there is electricity all over the wheels and things, and it is getting worse every minute. Now, you don't suppose that watch is going to clean itself, do you? Of course not. You must have a good watchmaker get that pesky stuff out of it and straighten things up. And then you must keep it away from that fellow's store unless you want it ruined again."

I charge \$2.50 for cleaning electricity out of a watch, because it is a very difficult job to do thoroughly. I keep it a secret, but if any of your readers would like to learn how, I will sell them the receipt for \$5, with full instructions how to use.

The fact is, that most all watches are more or less infected with electricity, and anybody who learns how to exterminate it can do a rushing business at it. One man in every town ought to learn how.

Hoping you will print this for the good of the fraternity.

J. W. P.

After the laughter caused by the reading of this letter had subsided, Mr. ELECTRODE remarked that it furnished very timely and convincing proof of the necessity for such an organization as ours, to supply information on obscure technical matters. He feared that our correspondent was afflicted with cobwebs on the brain, and would advise him to subscribe for THE JEWELERS' CIRCULAR and read every number carefully. He would also do well to get the back numbers for the past six months, and read the series of articles on "Electricity and Magnetism," by EXCELSIOR. He would then perceive that his supposed discovery was really only a misapprehension on his part, due to lack of information about electricity.

It would be impossible within the limits of space accorded to us for our reports in THE JEWELERS' CIRCULAR, to correct his mistaken ideas and explain the true state of things. We can only advise him to inform himself about electricity, by books or otherwise, when he would himself see his error.

Mr. EXCELSIOR thought that if that letter was to be printed at all more definite comments ought to go with it. He would say that watches do not become "charged with electricity," but they often become *magnetized*, and can be demagnetized by proper apparatus. But no man should ever bring a powerful magnet near a watch as described by Mr. F., as it will be sure to magnetize it and injure its time keeping qualities. Every possible care should be taken to keep magnets away from watches, and also from all tools which come in contact with them. Finally, cleaning a magnetized watch does *not* free it from magnetism. That can only be done by the proper use of some kind of magnetic device, and it requires no cleaning, nor even taking the watch apart.

Our correspondent's "receipt" will therefore be of no benefit to anybody, so far as removing "electricity" from watches is concerned. We wish to be as lenient and polite as possible, but Mr. F. certainly cannot expect us to commend anything which we know to be entirely wrong.

DIMENSIONS OF THE ESCAPEMENTS OF AMERICAN WATCHES WANTED.

To the Editor of the Jewelers' Circular:

Can you send me the correct dimensions for drawing the escapements of the Elgin, Hampden, Wallham and Springfield, Ill., 18 size watches? I will be glad

to pay you for your trouble, and will remit in advance if you will inform me of the amount. J. M.

Mr. RUBY PIN thought that it would be rather difficult to obtain the exact measurements, except by applying to the factories of the various watch companies, and would advise Mr. M. to do that if the matter was of importance to him. If any of our readers have the dimensions we will be glad to put them in communication with Mr. M. if they will inform us.

RECOVERING GOLD FROM WASH WATERS, ETC.

To the Editor of the *Jewelers' Circular*:

How can I recover the gold from my coloring baths and the waters I pickle and wash jewelry in? And how can I tell whether I have got all the gold out? I do not want to throw away half of it, but would like to test the wash waters for gold. A. S. C.

Mr. ROLLIVER responded: Pour all your wash waters together. If convenient, warm them when ready for precipitating, but that is not absolutely necessary. Make a precipitating solution by putting into a dish of boiling water all the sulphate of iron it will dissolve. Pour some of this into your wash waters and stir thoroughly. This separates the gold, which then settles in very fine particles. Next take a little of the clear water, to test for gold, in a glass tumbler, or even in a watch crystal, so that you can observe it closely, and add to it a few drops of the sulphate solution. If this produces any clouding or precipitation of gold in the crystal, there is, of course, some gold left in the rest of the wash waters also, and you give them another dose of the sulphate solution, stir well and test again. Do this until the water tested in the crystal remains perfectly clear after the addition of sulphate solution, and you have then precipitated all the gold from the waste waters. Allow the gold to settle, then draw off the clear water, being careful not to disturb the sediment, which is the precipitated gold. Wash this thoroughly with boiling water, three or four times, as usual, then dry and melt.

CURIOUS BREAKS IN MAINSPRINGS.

To the Editor of the *Jewelers' Circular*:

I enclose a spring barrel containing a broken mainspring. As nearly as possible this represents the position of the different coils, as removed from the movement. It was taken from a key wind Elgin 11 jewel movement. Thinking that possibly it might prove of interest to you and others interested in the trade, I take the liberty of sending it to you. Respectfully, V. S. MERRITT.
Easthampton, Mass.

Mr. UHRMACHER said that such cases were not infrequent in large repair shops, being more often met with in English and Swiss than in American watches, owing to the better quality of the mainsprings in the latter. In the specimen sent to us (of which a cut is inserted herewith), the spring was probably wound tightly when it broke. The fracture was, perhaps, caused by the arbor hook projecting out too far into the barrel, or a small piece of some hard substance may have got in between the coils there. The coils being strained tightly over it produced a sharp bend at that point in all of them, and the breaking of one coil precipitated the fracture of the whole series, either simultaneously or almost instantaneously one after the other. When broken, the coils spring outward and rest against the outside of the barrel, where they, of course, occupy less angular space than they did around the arbor, thus leaving an opening between their ends. Sometimes the ends of the pieces will be found arranged in perfectly straight lines, radiating from the center.



What causes mainsprings to break is one of the mysteries of the trade. But it would seem that these wholesale fractures are most common in springs which have rather hard temper. If any of our readers have facts indicating a probable reason for the breakage of a spring evenly and properly hardened and tempered, and without any undue bending or other apparent inducing cause, we should be pleased to receive their statements and theories for discussion. For if we could ascertain the cause it would doubtless lead to some method of preventing breakages—at least to a large extent. This would be a result of very great importance to the trade, but perhaps not “devoutly to be wished for” by watch repairers.

A motion to adjourn was then made, and as the hour was late it was unanimously carried.



[THE CIRCULAR is not responsible for the opinions or statements of contributors, but is willing to accord space to all who desire to write on subjects of interest to the jewelry trade. All communications must be accompanied by a responsible name as a guarantee of good faith. No attention will be paid to anonymous letters. Correspondence solicited.]

“DO WE MAKE WATCHMAKERS TOO FAST?”

To the Editor of the *Jewelers' Circular*:

I was much interested in reading the communication of J. W. Hall, in the last CIRCULAR, and beg to present through your columns a few thoughts of my own on this question, that is now being agitated so generally.

To properly answer this question involves an investigation into the conditions of the trade at the present time. The true state of affairs is, watchmaking has been drifting into a deplorable condition for many years; good workmen becoming scarcer and scarcer, and botches more and more abundant. If we are to produce or make more so-called watchmakers, let us in the name of mercy make better ones. The production of watchmakers for the last fifteen years cannot be better instanced than by telling the actual conditions and methods employed for the time named in one of the largest towns on the continent. A workman, formerly a turner, from the United States factory, at Marion, N. J., opened a place where he did “pivoting;” he could do a fair job at pivots, but on other parts of a watch was worthless. In fact he could not have held the position of watchmaker in even a third rate place, for the repair of watches, for a single day. But many otherwise good workmen dreaded to put in a pivot, because they had only imperfectly learned the trade, and these men patronize our “pivoter,” and he, to extend his gains “took in” several young men “to learn the trade,” at a fee of from one to three hundred dollars. When these apprentices were through they could do nothing but “pivot;” and they in turn set up “to work for the trade” and do pivoting, and the price of pivots forthwith went down from 75 to 25 cents; these dupes went on from one step to another, through “the soft solder brigade,” until they “picked up” enough skill to creep into positions at any price (5 to 10 dollars per week.) Now let me relate actual experiences and describe some specimens for a *horological museum*. A man running a place for himself and keeping a fair stock of goods, bushes the foot to a P. S. Bartlett balance staff, making the bush do duty of hole, jewel and end stone. A fair workman from the “old country” files off the “potance,” to raise it for a short staff to a Rockford movement. A first-class workman working for a big dry goods firm who sell a “few thousand” dollars worth of watches a year, *shellacs* in both pivots to a cylinder. A workman whose shingle reads “fine watch repairing a specialty,” recently informed a customer with a Frodsham pocket chronometer, that his watch was “no good, as it had no regulator on it.” These are not remarkable instances, but “as common as bad colds.” To convince himself let any good workman with a large run of work make note of the damage done to each watch which passes through his hands, by incompetent workmen, and he will find four-fifths of the deterioration of all the watches he examines can be attributed to unskillful workmen. These are facts, and will assert themselves, and “the want will provide the remedy.” Schools for the watchmaker are among the realities of the near future, and workmen who dread the advent of this class of artisans must either advance themselves or prepare to meet a competition vastly different from the average workman produced from the various sources of the past twenty years. If we are to produce only workmen capable of doing repairs like

those cited in illustration, we have too many now; but if really skillful men are the output, we need at this time several thousand.

NEMO.

THOS. NAPIER, WATCHMAKER, GLASGOW.

Schenectady N. Y. September 5, 1889.

To the Editor of the Jewelers' Circular:

We have in our family an old silver watch movement, engraved "Thos. Napier, Glasgow, No. 1601." Can you tell us *near* the time when Thos. Napier did business in Glasgow.

JAS. SANDERS' SONS.

[Chas. Gagnebin, 4 Maiden Lane, New York, at one time had in his employ as bookkeeper, a man by the name of John Napier, who was the nephew of Thomas Napier, a watchmaker who was doing business in Glasgow when he, (John Napier) as a youth came to America. This bookkeeper died in 1878 at the age of 91; so we infer that this 'Thos. Napier did business during the latter part of the last and the beginning of the present centuries. We know of no other Thomas Napier, watchmaker, of Glasgow.—ED.]

THE PRICE OF REID'S TREATISE.

Kissimmee, Fla., Aug. 27, 1889.

To the Editor of the Jewelers' Circular:

We have a copy of "Reid's Treatise on Clock and Watch Making," published by Blackie & Son, 1857, with 20 plates, 6th edition. Would you please let me know its value. It is in good condition—the binding being perfect.

P. D. HEADLEY & CO.

[The Treatise you mention is out of print, but is for sale by several publishers. The retail price is \$9. Your book having been in use for some time, is worth what it will bring, which, of course, is less than \$9.—ED.]

RELIC HUNTERS, ATTENTION!

Portland, Mo., Aug. 30, 1889.

To the Editor of the Jewelers' Circular:

Enclosed I send you pencil sketch fac-similes of some old flints or Indian arrow points that I have for sale. If you know any one desiring to purchase such old relics please let me know and very much oblige one of the craft.

LOUIS RIES.

[Geo. F. Kunz, the well-known mineralogist of Tiffany & Co., Union Square, New York, is interested in this branch of archæology. He is at present in Europe, and is expected home within two months.—ED.]

BACK NUMBERS TO BUY AND SELL.

SHARON, CONN., September 27, 1889.

To the Editor of the Jewelers' Circular:

I would like to dispose of ten or more back volumes of the CIRCULAR, to the highest bidder. I have Vol. VII, Nos. 7 to 12 inclusive, Vols. VIII, IX, X, XI, complete; Vol. XII, Nos. 1 to 6 inclusive; Vol. XIII, Nos. 3, 9, 10, 11, 12, and Vols. XIV, XV, XVI, XVII, XVIII, XIX, complete.

GEO. M. MARCKRES.

KIND WORDS.

Toronto, Sept. 5, 1889.

Kindly send me a perfect copy as I keep them for future references.

C. WRIGHT, Mgr. Ann. Clock and Jewelry Co.

Oakland, Cal., July 20, 1889.

Allow me to thank you for the many pleasant hours spent in the perusal of the CIRCULAR's pages.

T. S. HARDY.

Chatham, N. Y., Aug. 24, 1889.

Enclosed find check for the CIRCULAR for another year, as to be without it would be like eating bread without butter. No jeweler can do much or know much unless he takes the CIRCULAR.

E. D. ROOT.

Havana, N. Y. Sept. 9, 1889.

I consider it too valuable to lose.

W. L. HOPKINS.

Moncton, N. B. Sept. 12, 1889.

I appreciate THE CIRCULAR very much; it is really cheap at the price; it contains so much valuable information.

K. BEZANSON.

Pueblo, Colo., July 14, 1889.

To the Editor of the Jewelers' Circular:

While at the Centennial in Philadelphia, in '76, I saw the fac-similes of three or four very large nuggets (gold) found at either New Zealand, Queensland or in some other part of Australia, I forget which. Can you inform me of their history, size, weight, etc.?

CHARLES OTERO.

[In the Victorian Court of the British section of the Paris Exhibition are displayed 46 fac-similies of gold nuggets found in Victoria, Australia. Below are given the names, etc. of those found previous to 1876. We presume that the fac similies you refer to are included in the list. There is no extant complete report of the Centennial Exposition, as far as we know, and the reports in the contemporary newspapers contain no specific mention of the fac-similies.

Date When Found.	Name of Nugget.	Name of Place from which the Nugget was Obtained.	Depth from Surface.		Gross Weight.	Approximate Value.
			ft.	in.		
11 June 1858.....	Welcome.....	Bakery Hill, Ballaret.....	180	0	2,195 0	8,780
5 Jan. 1871.....	Precious.....	Catto's Paddock, Berlin... District of Avoca.....	12	0	1,717 0	6,868
31 May 1870.....	Viscount Canterbury.....	John Paddock, Berlin...	15	0	1,121 10	4,420
3 Oct. 1870.....	Viscountess Canterbury.....	Berlin.....	6	6	896 14	3,536
11 July 1872.....	The Schlemm.....	Nr. Wilson's Lead, Dunolly	3	0	533 5	1,912
17 April 1871.....	Kum Tow.....	Catto's Paddock, Berlin...	12	6	795 19	2,872
March 1861.....	Platypus.....	Robinson Crusoe Gully, Bendigo.....	5	0	377 6	1,508
About the year 1858.....	Beauty.....	Kangaroo Gully, Bendigo.	9	0	242 0	968
Nov. 1872.....	Spondulix.....	Eureka Gully, Jordan's...	8	0	155 10	520
2 April 1872.....	Crescent.....	John's Paddock, Berlin...	2	0	179 0	704
10 May 1871.....	Needful.....	Catto's Paddock, Berlin...	12	0	249 0	984
March 1871.....	Unnamed.....	Wednerburn.....			20 16	83
11 July 1875.....	Lothair.....	Lothair Co.'s Mine, Clunes	307	0	107 4	308
January 1871.....	Unnamed.....	Key Co's Mine, Creswick...			32 0	120
25 Dec. 1875.....	Unnamed.....	White Horse Ranges, Ball.	50	0	41 8	164
April 1873.....	The Oldham.....	Turton's Creek, nr. Foster.	2	0	36 0	144
11 March 1871.....	The Virtue.....	Chinaman's Flat, Mary- borough.....	220	0	30 0	116
14 April 1873.....	Alma No. 2.....	Alma Consols Mine, Mary- borough.....	120	0	19 10	60
8 Aug. 1872.....	Unnamed.....	Broomfield's Gully, Creswick	100	0	24 7	96
14 April 1873.....	Alma No. 1.....	Alma Consols Mine, Mary- borough.....	120	0	145 14	500

ALCHEMISTS.—The early alchemists sometimes made very boastful assertions; for instance, the very famous Gebir says: "Bring me the six lepers (meaning the six imperfect metals—silver, mercury, lead, copper, iron and tin) that I cure them" (by which he wishes to say: "that I convert them into the perfect metal—gold"). Raymondus Lullus (died 1315) goes still further in his assertion: "If the ocean were full of mercury, I could transmute it into gold." Basil Valentine, in the 15th century, asserted that the philosopher's stone could change from 10 to 30 parts of base metal into gold. And yet, how imppecunious we are.



[FROM OUR SPECIAL CORRESPONDENT.]

THE LONDON "MID-SEASON."—STRIKE OF THE DOCK LABORERS.—
CONDITION OF THE DIAMOND MARKET.—SEASONABLE NOVEL-
TIES.—CO-OPERATIVE EXHIBITION AT THE CRYSTAL PALACE.

LONDON, September 10, 1889.

The period since I wrote you is what may be called "mid-season," and considering this and also remembering that so many persons are holiday making, our manufacturers have no reason to complain either of sales from stock or of orders placed. Those who have gone to the trouble of keeping records each month, find that the business done lately has been better than in the same period for some years past.

The jewelry trade, however, is always affected by the general trade of the country, so that I fear an examination at the end of the current month will not show so favorable a result.

EFFECT OF THE DOCK LABORERS' STRIKE.

The strike of dock laborers may not seem a very relevant matter to allude to here, but its effects are so widespread that every industry is more or less influenced by it. In many industries it affects the laborers, in ours it affects the masters. The general condition of trade always affects finance, so that with the recent tendency to rise in the rate of wages throughout the country, there has been an inclination to advance the rate of interest charged by lenders of capital. The first effect of this is to reduce manufacturers' profits. The next step, if the advance is increased, or even maintained, is to check business and perhaps to divert some of it to other countries. We are all affected by the heavy trades of the country, and we know that a considerable portion of these is done on borrowed capital. There are capitalists with large fortunes who employ their money in trade, but they are the exception. The most energetic trader is the man who has a capital moderate in comparison with the business he is engaged in, and who borrows the balance necessary for a large business, contenting himself with the margin of 2 or 2½ per cent. on the borrowed money. He is always the most active, often the most successful trader. But if he has to pay one per cent. more for his borrowed capital, any extension of his trade is out of the question. The effect of this check on general trade is soon felt in our trades. It is thus that the strike of the dock laborers, which is not settled at the time I am writing, is felt even by manufacturing jewelers and silversmiths.

If there is a return to the normal condition of business as it prevailed before this interruption, there is every prospect of a very good winter's trade in the industries we are connected with. I hope before I write again this return will have been made and that we shall all be rejoicing in the brighter indications.

CONDITION OF THE DIAMOND MARKET.

To come from generalities to particulars, it is to be noted that the diamond market has been quiet. The consignments from the diamond fields have not been extensive, and prices have so advanced as to limit the sales. There does not appear to be any likelihood of lower prices just yet, as efforts are being made by combinations to sustain the rise. These combinations will, no doubt, effect their purpose, as they are backed by unlimited capital and controlled by shrewd and experienced men.

A great change has taken place in the art of diamond cutting since its cultivation in Berlin and other places. It is not so long since this industry was quite in the hands of the Dutch, but there are now several extensive diamond cutting establishments in Germany. The almost general use of steam power for the work has completely revolutionized the calling, and this, conjointly with the increasing number of firms engaged in the business, has tended to a great reduction in the profits.

Speaking of diamonds reminds me of a most singular ornament for the hair I saw lately. It was a diamond toad, with emeralds for the eyes. As a novelty it was a success—I cannot say much more for it. It was certainly not "lovely," and I believe this is the term ladies like to apply to anything they admire.

In connection with diamonds a strange rumor has been circulated in the trade lately, that a wealthy lady has placed with a well-known firm of jewelers an order for a diamond necklace that is to cost £25,000. The name of the lady is said to be Lady Guinness, but the "rumor" has not yet decided upon the "name of the well-known firm."

Diamonds and rubies are just now fashionable in London and in Paris. Ear rings are being restored to the place they so long held as ornaments for the fashionable. Diamonds are being introduced extensively in their manufacture. There was a splendid pair (among many) presented to the Duchess of Fife.

QUAINT SILVER JEWELRY.

I have just seen some very quaint looking silver jewelry. Its novelty will give it a place for a time. Articles made up with the fine gray surface it possesses do not look anything like silver. It is not likely to retain hold on public favor long. It has been made up, among other devices, into brooches, but as the demand for these is not so general as it was, the new style may help them somewhat.

"RINGS AND THINGS AND FINE ARRAY."

The ring trade is improving. There is a growing tendency to purchase the better class of rings, both gentlemen's and ladies'. Among the more expensive types of rings of the season is one set with three rubies, around each of which is a row of small diamonds. It is a showy ring without being too large.

THE CRYSTAL PALACE EXHIBITION.

A co-operative exhibition has recently been held at the Crystal Palace. I happen to reside very near the Palace, and taking a stroll there one evening with the idea of resting after many days' close work, I accidentally came across this display and forthwith proceeded to take some "notes." The display of watches and clocks is not an extensive one, but is augmented by the exhibits of the London and Coventry Watchmakers' Association, who show some jewelry, watches and clocks, but not in competition.

One of our London technical schools, the Polytechnic, have a section devoted to watch and clock making, and they have an interesting and varied selection of exhibits. They show workshop appliances and tools, as well as the work of their students. The appliances exhibited include special tools and instruments used in the school for making escapements and for setting out calibres of watches and clocks, and were specially designed for the purpose by the chief instructor, J. Herrmann.

Work executed by students is shown, comprising, among other things, parts of clocks and watches, a turret clock and compensating pendulum, a bracket clock and some tools made by the students. Some very well executed drawings of complicated watches and escapements were also shown. The following were the awards to this section: A silver medal to the school, a bronze medal to Mr. Herman, the instructor, three bronze medals to students and seven certificates. All were fairly deserved.

VIGILANT.

Obituary.

NATHANIEL GRANT.

In the death of Nathaniel Grant, which occurred suddenly, at Woods Holl, Mass., on Sunday, Sept. 8, Providence loses an old and prominent manufacturing jeweler. "Nat." Grant, as he was familiarly known to his host of friends was one of the most social and genial of men, and was endowed with one of the most generous of hearts.

Mr. Grant was 56 years of age at his death, having first seen the light on Sept. 23, 1833, at Great Falls, N. H. He learned the jewelers trade with Tift & Whiting, of North Attleboro', and about 1860, he started in the business of coloring jewelry in Providence, with Thomas Quayle. This partnership was dissolved after three years, when he associated himself with the late Charles Downs, for the manufacture of jewelry. The business prospered, but Mr. Downs retiring in 1866, Mr. Grant formed a partnership with Frank Bliss, of New York, with whom he remained till 1887, when reverses came and Mr. Grant retired.

The deceased was at one time first lieutenant of Company C, First Regiment Light Infantry, and was prominent at the visit of that regiment to the Centennial, at Philadelphia, Pa., in 1876. He was a director of the Warwick Club, a member of What Cheer Lodge of Masons, and of Calvary Commandery, K. T. He leaves a widow, daughter and one son.

The funeral services were attended by members of these various associations as well as by a large circle of friends.

WILLIAM FITLOCK LADD.

The demise of William Fitlock Ladd, which occurred on September 14, from hemorrhage of the brain, caused regret to a large number of business men, both in the Maiden Lane and Wall street districts. He had been suffering more or less for three months with rheumatic gout, but had almost recovered when on the day preceding his death, he suddenly became worse, and sank rapidly.

He was a large man, of commanding presence, who would attract attention anywhere, and the doctors had found the organs of his body so sound that it was expected he would continue his activity for some years yet.

Mr. Ladd was born in Devonshire, England, on September 2, 1807, and came to America when but fourteen years of age, as assistant to his brother, James, a chronometer maker, who had previously emigrated. When twenty years of age, having finished his trade, he formed a partnership with Mr. Treadwell, subsequently with Tiffany & Co., under the style of Treadwell, Ladd & Co., and commenced business in lower Broadway. The partnership was after a few years dissolved and Mr. Ladd opened his well-known store under the Astor House. In 1845, he moved his business to the corner of Wall and Broad streets, the site of the present Drexel building, where he remained for twenty-five years, when he again moved to 19 Wall street, where his business became quite a landmark. The spring of the present year saw his business removed to 104 Broadway.

The deceased was identified as official timekeeper with the Stock Exchange since its infancy, and the well-known signal "Ladd's 2.15 time" has made his name familiar throughout financial districts. He was one of the founders of the Mechanic's and Tradesmen's Library and was the means of placing the books of that institution into the hands of many young people. Of the nine children that Mr. Ladd has had only one survives—George W., who has charge of the business and with whom the old gentleman had lived since his wife's death, two years ago.

ELIJAH PEACOCK.

There is scarce an adult in Chicago who has not known, by sight at least, Elijah Peacock. He came to Chicago from his birthplace, Cherteris, Cambridgeshire, England, in 1837, being then nineteen years old, and at once began his career as a jeweler. Chicago, at

that time, did not amount to much, and Mr. Peacock was one of those very few men who could look back upon the village of fifty-two years since. Of those days, and those following close afterwards, he never tired of telling, and his presence, as well as his anecdotes, had such cheeriness, and his disposition was so amiable, that his hosts of acquaintances were everyone friends. Every one of them knew of his invariable readiness to show courtesy or kindness, and every one of them now speaks of his goodness and his sympathy.

While Mr. Peacock had nearly reached the end of our allotment, three score and ten, it was hard to realize this when standing before



ELIJAH PEACOCK.

the hale, sturdy appearing man, as he chatted with the friends who daily gathered round him in his son's store, and at his own home he showed such keen enjoyment when surrounded by his children and his grand-children, that none of them were prepared for the sudden loss. He is resting after a busy life of good works at our beautiful Oakland cemetery, and there has scarce ever been a burial ceremony in Chicago, which called together so many old and honored residents. Very many of these were quite as old as was Mr. Peacock, some of them were well on to the eighties, but not allowing any of the infirmities of age to hinder their coming, the presence of these, many who must soon follow, lent an added pathos to the burial service.

SIGMUND HYMAN.

On the fourth of the month, the President of the Chicago Jewelers Association again called a meeting; this time to take appropriate action on the death of Sigmund Hyman. Forty representative jewelers met at the rooms, 170 State street, with C. D. Peacock in the chair. A committee consisting of C. K. Giles, Edward L. Groff, Edward Forman, C. B. Shourds, Jas. Rowe and C. D. Peacock were appointed to engross resolutions of respect and sympathy, which were spread upon the records of the association, and copy sent to the bereaved family.

Mr. Hyman was born in Oppenheim, Germany, May 4th, 1826, and soon after he had come to manhood he emigrated to this country. He first settled in Indiana, but after a year's discouragement there he came to Chicago. He was then 27 years old, and he at once established the old market, which was a familiar landmark for a good many years, at the corner of State and Randolph streets; this he continued until the beginning of the war, then becoming a cattle contractor for the United States government. The war having ended, in 1866, the firm of Wendel & Hyman was established, and these two gentlemen conducted a jewelry store under the Tremont House, until the fire of 1871 destroyed it. In common with nearly every other firm located in the down-town business district Wendel & Hyman lost everything, but they managed to resume business, and their trade increased with each succeeding year, until in 1876, Mr. Wendel retired and Mr. M. H. Berg became a partner. The firm name was changed at that time to S. Hyman & Co., and was continued until Mr. Hyman's increasing ill health led him, while yet liv-

ing, to make ready for his sons' succession by placing Harry Hyman in his stead, and changing the firm name to Hyman, Berg & Co. This fatherly forethought was typical of the man. From first to last he was known as a far seeing, thoughtful, honorable business man, fulfilling every obligation. In business hours he first achieved success, and later insured its continuance, by strict attention, not alone to large affairs, but to all those little details, without which no lasting success is possible. He was an example during the busy hours of the day to his sons and every employe, and when the day's business was ended he was no less their example, in the whole hearted zest with which he entered into every social amusement; these traits naturally drew around him very many friends. No man was more honored than he in Jewish social circles, and no man was more respected for the integrity of his business methods. The burial services, which were held at the family residence, were simple, but they could not have been more impressive. The abundance of beautiful floral pieces gave testimony to the esteem in which Mr. Hyman was held by his friends outside the jewelry trade, and the Chicago Jewelers' Association was not alone represented by many of its members but also by a magnificent floral timepiece, with the hands pointing to the hour at which their brother had gone from them. Rabbi Hirsch, of the West Side temple, which Mr. Hyman had for many years attended, was out of the city; in his stead Rabbi Stolz conducted the services, and in his address he comforted the bereaved family and friends in the telling of the plain truth respecting the man they mourned; it was no fullsome eulogy, but none the less it gave comfort to the wife and to the eleven children, and incited all there assembled to take example from the honored life which had ended.

Mr. Hyman left an estate of perhaps \$200,000, but only \$35,000 of this was scheduled in the probate court yesterday, for the reason, before stated, that he disposed of his jewelry business among his children before the making out of his will. The will only refers to \$10,000 worth of personal property and \$25,000 of realty, which is left to his wife and to his son, Harry S. Hyman, to distribute share and share alike amongst the eleven children, when the youngest reaches the age of twenty-one.

FREDERICK W. GESSWEIN.

The jewelry trade of New York received a heavy shock on Friday, Sept. 13, when the report was spread around that Frederick W. Gesswein, the well-known manufacturer of and dealer in jewelers' supplies and machinery, had been murdered that morning, just after reaching his office at 39 John st. Within a few minutes, his store was besieged by a large crowd, among whom were many prominent jewelers, and the truth became known. The details of the crime, and the causes which led the old man, Christian Deyhle, to commit the dastardly act, are well-known. Deyhle, who has very little command of the English, in his incoherent statements to the police, holds in extenuation of his crime that his victim cheated him out of certain patent rights, which reduced him to a state of poverty and dependence. These statements have awakened considerable sympathy for the murderer, and the Chicago anarchists availed themselves of the unfortunate occurrence to vent some of their ill-will against social order and declared the crime justifiable, and Deyhle a hero.

Mr. Gesswein was forty years of age, and leaves a wife and six children. The funeral ceremonies took place on the 16th, from his late home in Brooklyn, and was attended by a large circle of friends, among whom were many jewelers.

The deceased was born in Canstatt, Wurtemberg, Germany, on July 20, 1849, received a good education and came to America when sixteen years of age. After being employed in numerous places and accumulating a little money, he secured the position of book-keeper in the tool house of F. P. Kurtz & Co., where he afterwards became manager. After a disagreement with Mr. Kurtz, two years later, the deceased withdrew and started in business for himself at 171 Broadway. There he sold jewelers' tools and appliances, such as

whip saws, piercers, etc. It was about this time he patented a felt wheel which proved very successful, and occasioned several lawsuits in all of which Mr. Gesswein was successful. In 1873 he entered into partnership with E. P. Reichhelm, and they occupied half of the store No. 33 Maiden lane. In 1876, Mr. Gesswein bought out Mr. Reichhelm's interest in the establishment which was then at 39 John street. After this dissolution business rapidly prospered, and in conjunction with a Mr. Weiman, a file factory was started in Paterson, N. J. Mr. Gesswein had also become identified with several other enterprises all of which were successful.

Mr. Gesswein was a member of Royal Arch Lodge, F. & A. M., and also of the Jewelers' League. In his will he appoints his wife and William Dixon executors of his estate. The business can be continued by them, as they are given discretionary power in the will.

ALZAMORA BUCK.

Alzamora Buck, for many years the New York manager of the New Haven Clock Company, died at his residence in Westfield, New Jersey, on Sept. 14, from heart trouble. Mr. Buck was well-known in the clock trade and universally respected. A man of sterling worth and integrity it could well be said that he possessed "that chastity of honor which felt a stain like a wound."

His loss will be deeply felt by his many friends in the city, and still more by those who were more familiar with him in his home life at Westfield, where for over a score of years he had been one of the staunchest pillars in the St. Paul's Episcopal church.

The deceased had been in poor health for the past year, but, notwithstanding the urgent request of the officers of his company that he should by travel and change of surroundings endeavor to restore his shattered health, he insisted on remaining at his post of duty. He seemed to have a premonition that his death was shortly to be, and quietly accepted the fact, confident in the words of the master: "Be thou faithful unto death and I will give thee a crown of life."



[FROM OUR SPECIAL CORRESPONDENT.]

ATTLEBORO, Sept. 23d, 1889.

The season among the jewelers has opened very auspiciously and my September trip among the various firms finds them preparing for a good Fall trade. It is to be hoped that these expectations will be fulfilled and that before the month is over all the shops in town will be doing a good business.

The Attleboro' cattle show closed Saturday, after a week of rain. In my inspection of the jewelry exhibit in the main hall, I found that many of the largest jewelers had failed to make any showing at all. The exhibits were arranged in large cases at one side of the hall, but hardly any one seemed to take any particular pains to make a good display. Probably the best was that of the firm of Bates & Bacon, the well-known watch case manufacturers. They showed a large number of filled cases, arranged in attractive form, and these were greatly admired by all. W. H. Wilmarth & Co., had a good show and so did Watson, Newell & Co. One noticeable feature was the absence of novel styles and designs. It seems a pity that in this, Attleboro's special fair, there cannot be a better showing of Attleboro's special industry.

H. A. Clark, of Horton, Angell & Co., is in Paris. His firm have an exhibit at the great exposition, and he has gone over partly on pleasure and partly to look after the firm's interests.

Mr. French, of the firm of Riley, French & Heffron, seems to

think that the season now opening will be the best the jewelers of this section have experienced since 1883. He told me that in a recent trip to New York, he found the buyers on the look out for new designs and generally ready to place good orders. He, however, complains of the slowness in collecting bills. Mr. French is a bright young man and has evidently made up his mind after taking a good look over the field.

Wade, Davis & Co., of Plainville, had a good showing of bracelets, pins and novelties at the fair, their case being a very attractive one.

H. P. Richards, a well-known jeweler, of North Attleboro, committed suicide by shooting, September 14th. Various causes are assigned for the deed, but it is probable that business troubles were the main reason. Mr. Richards had a host of friends in this town and his tragic end was sincerely lamented.

The Wamsutta House is open. Donath & Litterer, proprietors of the Benedict house, Pawtucket, are the new lessees and Ernest Litterer, is to attend to this house. Drummers will henceforth find good accommodations here.

MENDON.



[FROM OUR SPECIAL CORRESPONDENT.]

ATLANTA, September 18, 1889.

Since I last wrote you, the warm spring days have passed away and the cool, refreshing breezes of Autumn have come. The large number of people who spent their summer months in the north and east, at the watering places and in the mountains, have returned to their places of business, and have their shoulder to the wheel pushing along.

The outlook for this season's business has never been brighter; good crops, plenty of cheer, and everybody feeling in a good humor, gives a very healthy tone to business and a very flattering prospect. The jewelry trade for September has been remarkably good. All of the buyers in the city have been in the east and in Europe, laying in large stocks of goods. The trade during the past month has been devoted almost entirely to purely staple articles, such as diamonds, watches and solid jewelry. From now until after the holidays is the time to sell bric-a-brac and goods of similar character. We note that large additions have been made to several of the retail jewelers' establishments in this city, which fact means much.

The jewelers' trade throughout the country and especially in the South, has been more or less affected by these cheap-John concerns and premium business. I am glad to say, however, that none of our merchants are engaged in that sort of business. They are all straight forward, reliable men and do not run on the cheap-John style.

I was talking with one of the largest jewelers in this city a few days ago, relative to the merits of certain goods. He said that a great many filled watch cases were sold now-a-days in the South. It looks just as well, and is perhaps as durable as a solid gold case. This fact has given the jewelers quite a trade on this style of watches.

With a large fruit crop, and unprecedented cotton crop, and an abundant grain crop, in the South this year, there is no doubt that in the next twelve months a very large trade in the jewelry line will be carried on. This is the expectation of everyone engaged in the business and I believe it will be realized.

A. L. Delkin, of A. L. Delkin & Co., has just returned from an extended trip through the East, in the interest of his house. He is what you might call one of the hustlers, and is doing a big business.

L. Snider has moved his store from 10 Marietta street to 84 White-

hall street, where he will be in close proximity with all the other jewelers in the city. This was a good move.

A. F. Pickert is at home in his beautiful little store on Whitehall street. He is regarded as one of the best jewelers in the city. He has been thoroughly educated in this business.

J. H. Peoples who has been with L. Snider, for many years, has resigned his position there, and has accepted a very lucrative one with A. L. Delkin & Co.

T. J. K.

Visiting Dealers should call at the Establishments of

Stern & Stern, 13 Maiden Lane, who say they have better lines this season than ever before, and claim them to be the equal of any in the trade.

S. Cottle Co., 860 Broadway, where in addition to their well-known handsome line of staple goods, can be examined a full assortment of their new patent button.

Henry Dreyfus & Co., 25 Maiden Lane, who are receiving constant shipments of diamonds, pearls and other precious stones, and whose Fall stock is of especial excellence.

Thomas G. Brown & Sons, in the same building, where will be found a profusion of sterling silver novelties prepared for and admirably adapted to the Fall and Holiday trade.

Edwin A. Thrall, 3 Maiden Lane, who has prepared for the Fall trade the largest stock of new goods consisting of jewelry, precious stone mountings and watches, he has ever shown.

Hayden W. Wheeler & Co., 2 Maiden Lane, where is displayed complete lines of watch cases and movements, gold plated chains, fine gold and plated jewelry, and diamonds and other precious stones.

Albert Lorsch & Co., 37 Maiden Lane, whose line of richly ornamented diamond watch cases has been greatly added to, and whose stock of diamonds, watches and jewelry is now complete for the season.

Pforzheimer, Kelter & Co., 24 John street, where they will find, besides extensive lines of American watches, diamonds and jewelry, a full assortment of elegant diamond-ornamented watch cases which the firm is making a specialty of this season.

The Middletown Plate Co., 22 John street, at the invitation of the company and inspect a full assortment of staple table ware and fancy goods, brushes, combs, manicure sets, small wares, candelabra and everything in the line of electro-plated ware.

Taylor & Brother, 860 Broadway, where they should examine before purchasing elsewhere, their elegant assortment of marble, travelling, onyx clocks, gilt regulators, and clock sets in porcelain and gilt, brass, etc., that have just been received from across the water.

J. Eugene Robert & Co., 30 Maiden Lane, who have just received invoices of Agassiz and Longines movements, Louis Audemars and Jules Monard superior timekeepers, of which they are sole agents, and chronographs, making their fall stock unusually complete and worthy the consideration of dealers.

Miller, Bros. & Co., 37 Union Square, whose safes are filled with new designs in 14 kt. gold lace pins, brooches, lockets, medallions, scarf-pins, hair-pins, buttoners, sleeve buttons, sleeve links, studs, etc., and whose line of well-known and beautiful initial and *cloisainé* goods has been increased by new patterns.

J. B. Bowden & Co., Corbin Building, whose new safes are filled with snake, twist wire, rope, and other fancy rings with diamond, ruby, pearl and emerald combinations gotten up to satisfy the prevailing craze for this class of goods; and where the whole population of New York might be supplied with rings, so extensive is the line.

J. T. Scott & Co., 4 Maiden Lane, where they can inspect an extensive assortment of the popular "Anti-Swear" cuff buttons, full lines of the "Leader" split-second open-face watches, "Success" interchangeable initial rings; besides complete lines of American and Swiss watches, jewelry, chains, diamonds mounted and loose, etc.

Ketcham & McDougal, 198 Broadway, who carry perhaps the largest line of gold and silver thimbles in the country, which for beauty of design and excellence of finish is unexcelled if equalled; and where the visitor can inspect their assortments of Nos. 103 and 105 (new), advertised on another page, which are handsomely ornamented though sold at the same price as the plain thimbles.



Awards to American Exhibitors.

By cablegram received in New York on Sept. 29th, the following are the principal awards to American Exhibitors at the Paris Exposition in the line of horology, jewelry silverware, etc.:

Darling, Brown & Sharpe. Machinery.....	Gold Medal.
Fairchild, Leroy W. Co..... Pens	Grand Prize.
Gorham Mfg. Co..... Silverware.....	Gold Medal.
Hawkes, T. G..... Crystal.....	Grand Prize.
Herring & Co..... Safes.....	Gold Medal.
Meriden Britannia Co..... Silverware.....	Gold Medal.
Tiffany & Co..... Silverware.....	Grand Prize.
" "..... Jewelry.....	Gold Medal.
" "..... Leather Goods.....	Gold Medal.
U. S. Naval Observatory (Standard Time, Seth Thomas Clocks).....	Grand Prize.

These are all that have been received up to the hour of going to press, but others are expected to follow.

—Day & Clark, New York, have been admitted members of the New York Jewelers Board of Trade.

—R. & L. Friedlander, 65 Nassau street, New York, will shortly have ready their new jewelry catalogue, which will be very complete.

—Chas. Van de Sande, of Chas. Van de Sande & Co., 198 Broadway, returned from a two weeks' trip among his friends in the south, and reports business indications to be good in that section.

—It is rumored, *The Aurora Democrat* says, that John C. Dueber has offered to buy the stock of the Aurora Watch Company at 40 cents on the dollar, and to keep the works running for five years.

—Henry E. Oppenheimer & Co., manufacturers of diamond mountings, 47 Maiden Lane, New York, have just introduced a new base-setting earring, that is neat, simple and pretty, and that has already manifested its selling qualities.

—On Sept. 18, was solemnized the marriage of Louis Moss, of R. & L. Friedlander, New York, and Miss Julia Goetz, of Harlem, New York, at the bride's home. *On dit* that the bride is a young lady of marvelous beauty and rare attainments.

—Pinnell, May & Co's new case, the "Tip Top," is well named for it possesses merits that make it a sort of *multum in parvo*. It is a 14 kt case, weighing about 16 dwts., constructed in such a manner that it will stand as much wear and tear as a much heavier case. See their novel advertisement.

—Josiah Cummings & Son, 10 Summer street, Boston, Mass., the old established trunk house, make a specialty of steel bound sample trunks and sample cases for jewelers. The trunks of their manufacture have an enviable reputation for strength and durability and are now in use by many jobbers and manufacturers. If desired, they make special trunks or cases to order.

—The project for a watch factory for Houston, Tex., is still being agitated and the outlook is said to be favorable toward the establishment of a good plant at a not very remote date. Several capitalists have expressed a willingness to take stock in the proposed enterprise. It is claimed that a little work would result in something definite, but there is no one in the city to push the matter.

—The trade is warned against the machinations of William Ulmar, a man about 60 years of age, tall, stout and with a good-sized seedy beard, who was for several years with E. R. Stockwell, the well-known badge manufacturer, 19 John st., New York, and who, during the past month or so got small amount of goods on credit from R. & L. Friedlander, and several other firms, skipped the city and has not been heard from since.

—In mourning jewelry, in which Gilbert T. Woglom, 32 John st., New York, manufactures bracelets, earrings, brooches, lace pins—in fact every style of jewelry manufacture with the exception of rings, there is at present no article more fashionable and in greater demand than the memorial locket, which the above-mentioned manufacturer makes in 13 sizes, in oval and oblong shapes, and in smooth design and ornamented with diamond monograms

—We have received from the publisher, C. F. Denison, a copy of the "Standard Directory of Manufacturers of Jewelry, Silverware, Watch cases, etc., in the United States and Canada," for the years 1889-1890. It is an accurate and complete compilation of these branch of the trade.

—As the pedestrian wanders through Maiden Lane, he cannot help admiring the beautiful show windows which are beginning to take on their holiday look; and no window, perhaps, is more handsomely attractive than that of Chas. S. Crossman & Co. The effect of the bright gold and silver with the black velvet is most striking; and is enhanced by the tasty arrangement of the numerous articles—pretty silver novelties and snake rings, watch cases, and masonic goods, and gold and enamel goods, all bright and new. Many of the articles sit snug in beautiful plush boxes, and altogether the window is an example of tasty display.

—Changes and improvements are being made at the New York office of the Julius King Optical Co., 4 Maiden Lane, but improvements are of such ordinary occurrence with this enterprising house as to attract little notice. When the representative of THE CIRCULAR entered, Mr. Wormser was crying, "More room," and more room he must have if, in order to get it, counters and desks must be relegated to the cellar. The unusual demand for Mack's patent opera glass holder and the "Elite" test cases is largely responsible for this temporary upheaval, and under these circumstances Mr. Wormser can afford to look with complacency upon it.

—L. J. Mulford, manager of THE CIRCULAR, who was appointed judge in the competition for the \$50 prize offered for the best single stone ring design, rendered his decision on September 16, in which he said: "I have carefully examined the various designs submitted and am of the opinion that the prize, \$50, should be awarded to Eugene J. Franz, of Canton, Ohio, whose design is not only novel, practical and pretty, but I think will prove to be a good selling pattern. I think also that special mention is due to several other designs, notably those submitted by H. B. Swart, of Worcester, Mass.; George H. Rentz, of Kansas City, Mo., and James T. Wise, of Elmira, N. Y." A check for \$50 was duly forwarded Mr. Franz.

—The popularity this season of sterling silver small wares and trinkets is manifested by the fine and full lines prepared by manufacturers. In the extensive stock displayed by the Sterling Company which contains new conceits to an almost endless number, in all lines, a special feature seems to be made of toilet articles, such as combs, hair, clothes, nail, military and other brushes, which are of unusual excellence in both design and finish. Another noticeable feature is a line of odd leather goods sterling silver mounted, which are having a fine sale. These goods form an unusual line in silver trinkets but their present popularity will undoubtedly make them a staple for some time. Full lines of samples of the Sterling Co. are always to be seen at their New York office, 176 Broadway.

—At the cut glass show rooms of C. Dorflinger & Sons, 36 Murray street, New York, jewelers will find a superb line of the finest pieces of this now popular class of goods, as well as a large assortment of inexpensive pieces, adapted to the wants of people of moderate means. Among their latest additions are a variety of new shapes and styles of flower vases and holders; punch bowls of "Florentine cut," water, claret and champagne jugs; celery dishes, now in season, particularly noticeable among these being a leaf-shaped pattern; magnum toilet bottles with resplendent stoppers three inches in diameter, which the house claim cannot be duplicated anywhere in the whole country, and a line of bonbon dishes at prices from \$2 75 upwards. This house carries the largest and finest assortment of cut glass goods to be found in the market to-day.

—For the new patent gold pens which Aikin, Lambert & Co., have placed on the market are claimed: 1. A largely increased surface for retaining more ink by means of a matted or granulated surface on the inner surface of the pen. 2. Better adhesion for holding ink. 3. Less liability of dropping ink. 4. A more uniform flow or feed. 5. A better spring for action. 6. These pens always retain their adhesive qualities, never become smooth like the ordinary pens which are simply abraded or very slightly roughened by a scouring process and by little use and frequent wiping become perfectly smooth both inside and out, destroying the adhesive qualities and hence, causing a dropping of the ink. By this firm's process the matted or granulated inner surface being produced by compression prevents the gold from spreading while under pressure, hence a greater density of metal is obtained and a more uniform thickness of nibs than can be obtained by the old way of hammering, where the hammer blows are unequally distributed over the surface and tend to spread the gold without sufficiently hardening it.

—A leading watch house in Dayton, Ohio, writes to Berlin Demagnetizer Co., 177 Broadway, New York: "The demagnetizer arrived all right and is the source of much pleasure. It works like magic and we consider it the best investment we ever made." We would advise watchmakers having a good trade to examine the qualities of this demagnetizer.

—The solid silver loving cup offered as a prize to forty-footers in the June regatta of the Atlantic Yacht Club, and won by the Scotch cutter *Minerva*, was on exhibition last month at Ackerman, Bicker & Manvels, 6 Maiden Lane, New York, the designers of the trophy. It was a praiseworthy piece of workmanship, the decoration being appropriate, novel and artistic.

—The ten dollar prize offered by Henry Haskell, manufacturer of rings and jewelry, Corbin building, New York, to the first retail dealer who could, without having seen the trick performed before, put together his famous puzzle ring within one-half hour, was won by J. B. Wilkinson, of Camden, Me., who unraveled the intricacies in twenty minutes, ten minutes within the limit.

—J. F. Fradley & Co., 23 John street, have a reputation second to none for fine gold and silver headed canes, cigarette cases, etc. They have recently added a full line of novelties in repousse silver, including toilet sets, cigarette cases, etc., etc. Their new factory at the corner of Frankfort and Pearl streets, is as well equipped as any in the land for the manufacture of goods of this class.

—The Waltham key ring advertised in this number of THE CIRCULAR, possesses several advantages over anything of the kind now in use. The chain with its short bar catch is flexible and easily conforms to the shape of the pocket without any uncomfortable feeling of pressure. Another advantage is that the key can be taken off at either end, rendering it unnecessary to remove more than a few whatever key is desired.

—Champanois & Co., manufacturers of gold jewelry, 5 Maiden Lane, New York, are noted for the variety of patterns which they are constantly offering to the retail trade. They make a full line of novel, yet staple goods, including scarf pins, charms, earrings, lace pins and brooches, chiefly in polished finish. In white stone goods they are one of the leading houses, using only the finest grade of stones, of their own importation. One of their specialties is the "Best Lever" sleeve button, illustrated in such an original manner on another page.

—James W. Queen & Co., Philadelphia, have issued a fine series of cards showing, beautifully engraved, the eye, in all the natural colors and shades of each color. From these cards artificial eyes may be ordered by mail. The price of the cards complete is \$1, and they may be had from Queen & Co. direct or from any optician. This firm has added an operating room to their artificial eye department, where artificial eyes are inserted by competent people employed for the purpose.

—The eager demand for gold and silver necklaces and miniature brooches does not wane. They are, undoubtedly, at the present moment, the most popular articles in the line of finer jewelry. The factory of John A. Riley, at 860 Broadway, New York, is running to its utmost capacity, turning out large quantities of new designs, which uphold the high reputation of this house for beauty and general excellence of workmanship. Mr. Riley reports general increased business, not only in these lines, but in his other handsome lines, hair and side combs, bracelets, etc.

—Emile Krauth, has commenced business as a designer of diamond jewelry and has opened an office in room 29, 169 Broadway, New York. Mr. Krauth was till recently, for eighteen years with Randel, Baremore & Billings, occupying the positions respectively of apprentice, workman, and foreman and designer. As the demand for novelty and beauty in design in jewelry is yearly becoming more and more arduous to accommodate, we would think that the field for such an artist would be good. Mr. Krauth will make a specialty of designing for private and order work.

—The latest thing in the way of catalogues is of that Morse, Mitchell & Williams, which is now in press, and which will be ready for the trade by the time that this is read. Since this firm succeeded F. E. Morse & Co., it has had about all the business it could attend to, and the publication of this catalogue will still further increase the rush they are having, for the reason that it gives a comprehensive description of the many lines of goods exclusively controlled by this house. This same reason should induce all readers of THE JEWELERS' CIRCULAR to send for one. The address is 137-139 States street.

—Fowler Bros. have put upon the market an astonishingly large assortment of bon-bon boxes and vinaigrettes. The number of patterns mounts up into the hundreds and each is a study in point of richness and novelty of design. These goods are in great demand among the finest retail trade.

—At the International Congress of Prehistoric Anthropology, held recently in Paris, George F. Kunz, of Tiffany & Co., presented papers on the following subjects: "A Gigantic Votive Adze of Jadeite from Oaxaca, Mexico;" "A Jadeite Tablet from Santa Lucia Cotzumaguaha, Guatemala;" "A Remarkable Copper Turtle from the Casa Granda at Chihuahua, Mexico," and "The History and Manufacture, by the Whites for the Indians, of Wampum, traced back to 1740." These communications were listened to by the members of the Congress with much apparent interest.

—Among the special features of the bewildering display of novelties for the jewelry trade which are stored in the vast establishment of L. Straus & Sons, 42-46 Warren st., New York, may be mentioned lamps, bronzes, (both French and real) marbles, onyx clocks and tables, artistic metal goods, smoking sets, candlesticks, piano and banquet lamps, writing sets, moorish ware from Bohemia, Hungarian ware, now reviving; Bonn art goods in styles and shapes of their exclusive importation; Teplitz ware and a large line of Bisques in new subjects. One of the prettiest of this season's importations is an English ware with water lily decorations, sold at very reasonable prices.

—Jules Dubois, of the Dubois Watch Case Co., Brooklyn, N. Y. has patented what is termed a convertible watch case designed to contain a souvenir or love token instead of the old-fashioned brooches heretofore employed for this purpose. In outward appearance this case does not differ from the ordinary one. The peculiarity lies in the back of the case where the fancy decoration is generally applied. Here there is a circular panel which can be removed to make room for a panel of different design or for a glass. Inside the case and on the covering, which in key wind timepieces is perforated by two holes for receiving the key, is a small, circular frame intended to contain either a photograph or a lock of hair. The picture or ringlet can be seen through the glass if desired, or a panel in conformity with the remainder of the case can be inserted, and the portrait kept secret. This, which they have named their "patent medallion case," is a very important improvement, and is sure to meet with a large sale.

—On Wednesday, Sept. 18, the New York Jewelers' Board of Trade held a special meeting to revise their by-laws with the object of inducing the general trade to become members of the Board. The initiation fee was done away with until such time as there are 150 names on the membership roll which at present contains about 100. It was decided to hold another special meeting on the 24th, for the purpose of electing a president to succeed the late William Smith. At this meeting Leopold Stern, of Stern Bros. & Co., was elected President, Gurdon W. Hull, of Simpson, Hall, Miller & Co., 1st Vice-President in place of Mr. Stern, and Edward J. Scofield, 2d Vice-President in place of Mr. Hull. The benefits of the Board of Trade to its members are being daily more and more appreciated and deserve the serious consideration of non-members. Besides the inducement of free initiation, invitation is held out to any reputable dealer to try the system of the board by sending in a number of claims for collection and a number of trade entrees for their reference department.

—The annual election of officers of the New York Jewelers' Association, was held on Tuesday, Sept. 24, at its rooms, 140 Broadway, and was well attended. The first ballot for the election of a president for the ensuing year resulted in favor of A. K. Sloan, which honor was declined by a representative of that gentleman, urging Mr. Sloan's many business obligations as the excuse. In consequence another ballot was taken, which showed that Henry Randel was unanimously elected. The other officers elected were as follows: J. B. Bowden, vice-president; Henry Ide, treasurer; A. E. Pritchard, secretary; A. H. Smith, George W. Shiebler, F. S. Douglas, C. A. Fowler, N. Geoffroy, J. E. Robert, W. H. Atwater, J. F. Chatellier, and J. G. Bacon, board of directors. It was decided to admit free of initiation fees, the first twenty-five firms who apply for membership before January 1, 1890. Several improvements in the collection department submitted by the secretary, were referred to the executive committee with power to act. The treasurers report showed that the organization had had a prosperous year. Arrangements are being completed for the annual dinner at Delmonico's, on Nov. 21, and which promises to be the most successful ever held. Mr. Randel having declined for business reasons, a meeting will be held on Tuesday, October 1st, to elect a president.

—The Spencer Optical Manufacturing Company, New York, have been admitted a member of the New York Jewelers' Board of Trade.

—Bowman & Musser, jobbers, Lancaster, Pa., are at work on a new material and optical catalogue which will surpass in completeness and style any they have previously issued.

—John Holland, of gold pen fame, has been in the East for the past two weeks to matriculate his son at one of the Universities, and also to look after his business interests in that section.

—Ludwig Nissen & Co., 18 John street, have in stock what they justly claim to be the finest large opal in the United States. It weighs nearly 22 carats and shows a superb combination of fire and color.

—Jonas, Dorst & Co., 169-171 Race street, Cincinnati, have mounted up a very fine line of scarf pins, lace pins and fancy rings, for the holiday trade. They also carry a very complete stock of loose diamonds at advantageous prices.

—L. Tannenbaum, of L. Tannenbaum & Co., importers of diamonds and precious stones, 64 Nassau street, New York, returned recently from a three months' sojourn in Europe, where he purchased largely and at great advantage, as he was on the ground in advance of the phenomenal rise in prices.

—The new tea set illustrated by the Hartford Silver Plate Co., of Hartford, Conn., is a very artistic pattern. The wares of this company are deservedly prized by the retail trade for their sterling merit and their tasteful design. This season are shown a number of choice patterns in old silver that the trade would do well to inspect.

—Koch & Dreyfus, 22 John street, report a gratifying increase in their business since their removal from New Orleans. They have not only added many new customers, but their old customers have caught the spirit of push and enterprise that prevails in the office at 22 John street, and are ordering more freely than ever before.

—The factory of Jos. Noterman & Co., 203-205 Race street, Cincinnati, is running full time with plenty of orders ahead. The "Olympus" white stone goods are well in the lead, while the repair department and the mounted goods come in a close second. Mr. Noterman is always to be found "on deck," in the very thick of the fight.

—Among the recent arrivals from European diamond marts was Leopold Stern, of Stern Bros. & Co., 30 Maiden Lane. He spent several months inspecting the markets and as he was fortunate enough to finish his buying before the balloon ascension that struck the European diamond trade, purchasers should not fail to see the results of his trip.

—Henry Zimmern, importers and wholesale dealers in watch materials, tools and optical goods, has fitted up his store in 37 Maiden Lane, New York, in a most convenient manner for the handling of his immense and varied stock. Mr. Zimmern spent the summer in Europe, and saw all that could be seen in his lines, and, no doubt, secured all the meritorious novelties.

—The vacation season is over and schools and colleges have opened their doors to receive pupils once more. Jewelers may, therefore, expect to get inquiries in the next sixty days for class pins and rings. E. R. Stockwell, 19 John street, has made a specialty of furnishing designs for these for many years, and knows just what is wanted. Send to him for designs if you have need of anything in his line.

—Taintor & McAlpine, Easthampton, Mass., are meeting with good success in the sale of their watch club outfits and drawing machines, advertised elsewhere in this issue, having filled several orders from various parts of this country and Canada. They report to us, that as far they have heard, jewelers find but little trouble in organizing clubs, and in many instances, the advertisement afforded by the use of their machine, has enabled those to secure the requisite number of members, who had before been unsuccessful.

—One of the most pronounced hits of the season is the "Shakespeare Bangle," designed and manufactured by Frank H. La Pierre, 18 East 14th street, New York. It is a narrow bangle with some appropriate sentiment from the Bard of Avon, struck on the matted ground of the band. The mottoes are well chosen and at once please the fancy of the givers of love tokens. Another novelty in the same line is the "Shakespeare Ring," a series of coils resembling in structure the popular snake ring, and inscribed with mottoes similar to those that appear on the bangles. A big run is predicted on these rings.

—Jewelers would add to the attractiveness of their stocks and increase their trade by carrying the delicate and beautiful bric-a-brac "Belleek" china, made by the Ott & Brewer Co., of Trenton, N. J., whose advertisement appears on page 91. Nothing more suitable to jewelers' stocks can be imagined, and the popularity of this ware promises a bright future.

—The new rolled plate glove buttoner, illustrated by Foster & Bailey, in this issue of the CIRCULAR, is certain to prove one of the most salable articles that have appeared of late. It is so made that it can easily be fastened to the glove button, the watch chain or the button of the bosom, the flexible wire twisting easily to permit the locking of the balls at the ends. The price at which they can be sold by the retailer, brings them within the reach of everybody. Foster & Bailey have scored another success in their new calendar locket and game counter, a combination of the ornamental and the useful that is sure to please. Both of these articles are patented.

—The American Horological Institute, 1723 Chestnut street, Philadelphia, Pa., has published a prospectus giving the plan for instruction in all the various branches and quoting press notices of the enterprise. The officers of this institution seem to have the proper spirit. They are wide-awake and intelligent in their business methods and furthermore, they recognize the necessity of putting the institute on a sound practical basis, and have, accordingly, secured instructors and provided an equipment in the way of tools and machinery that are second to none in the whole country. All who contemplate a course in horology should communicate with the secretary, W. H. Dotter, 1723 Chestnut street.

—William Oskamp, of the firm of Oskamp, Nolting & Co., Cincinnati, O., returned from his recent European trip with the choicest lots of diamonds he ever secured. He spent several months in the markets to meet all demands that might be made upon this rapidly growing branch of their business, and finds himself well satisfied with the results. The same can be said of the customers of the house to judge by the manner in which these goods are being "gobbled up." Diamonds are trumps for every retail jeweler now and every lot Mr. Oskamp purchased is a trump of the highest order. They are, consequently, holding a "full hand," and are quite willing to share their good luck with their customers.

—"The Monarch" pattern illustrated elsewhere, by the Rogers & Hamilton Company, of Waterbury, Conn., is characteristic of this concern in the richness of its decoration and the careful adherence to the principle of fitness, which is the overruling one in all true art. The Rogers & Hamilton Company never sacrifice utility or the higher beauty that consists in harmony to a mere pandering for oddity. Indeed the wares of this young and vigorous concern have taken a position second to none for their sterling quality and tasteful pattern. They are preparing an illustrated pocket price list, which should be in the hands of every retail jeweler. It will be sent on receipt of business card to the legitimate jewelry trade only.

—The great ring firm of Ostby & Barton, 40 Clifford street, Providence, R. I., who have been compelled by the rapid increase in their business to take an entire new floor for factory purposes, are now quite at home in their enlarged quarters. A great deal of the newest and most improved machinery has been added, electric lights, new safes and other conveniences put in, so that we have no hesitation in pronouncing this the most complete ring factory in the whole country. They are preparing a larger line of their popular styles of fancy rings than they have ever shown before, while keeping their unequalled line of band rings fully up to its former standard in point of originality and variety of design and sterling workmanship.

—In the office of Wm. H. Ball & Co., the well-known manufacturers of bracelets, 15 John street, New York, is a little wooden case bearing the historical memoranda of the connection of the name of Ball with the house. This connection began in 1842, when the firm of Taylor & Ball succeeded a Newark firm, whose name has passed out of recollection. After a few years the entire business came into the possession of H. W. Ball & Co., H. W. Ball being an uncle of the present W. H. Ball. Ball, Barnard & Parsell, then came on the scene, to be soon afterwards succeeded by Ball, Barnard & Rogers. For years thereafter, Ball & Barnard was the firm style. The Ball interest was nominally that of the widow of the former senior member, although her son, Wm. H. Ball, managed the business. In 1878, he bought out the other two interests, and the name was changed to Wm. H. Ball & Co., as it stands to-day. Thus the name of Ball has been identified with this house for nearly half a century, during which the concern has occupied a leading position in the manufacture of fine bracelets. Sterling integrity in all business transactions and originality and reliability in all its manufactures have characterized the house throughout its long career.

—Harrison B. Smith returned last month from his six months' sojourn in Europe.

—We would advise every retail jeweler to read the open letter of McCarty & Company, page 100.

—Will. T. Jordan, Appleton City, Mo., has transferred his business from the store of E. M. King, to that of John P. Harris, of that city.

—The Du Bois Watch Case Company, 2 John street, New York, make a specialty of fine ornamented cases and turn out only first-class work.

—W. H. Vogell, representative of Alfred H. Smith & Co., New York, is in Europe sending over invoices of fine new goods adapted for the Fall and holiday trade.

—The elegant onyx ornamentation in the new building of Ehrich & Sons, New York, is the work of S. Klaber & Co., art workers in onyx and bronze, 47 W. 42d street, New York.

—I. Bedichimer, the masonic badge manufacturer of 618 Chestnut street, Philadelphia, is over-rushed with orders, in consequence of the coming triennial conclave of the Knights Templar, at Washington.

—G. H. Houghton, of the Gorham Manufacturing Company arrived in New York, from Europe, Sept. 1, for a short rest from his labors at the Paris Exposition, and left again on the 14th for Paris, where he remains until the close of the exposition, Oct. 31st.

—We would call the attention of all dealers in silver novelties to the advertisement of Lewis Bros., 41 Maiden Lane. During the summer months they have been making improvements in the factory and adding to their line many new patterns in their original style of workmanship.

—On the night of Sept. 5, the upper floor of the building occupied by C. E. Rose, Ouray, Cal., were destroyed by fire, and some of the stock, in moving it, was damaged. The building is being repaired and remodeled, and Mr. Rose will move back in a few days. He resumed business the next day after the fire.

—D. D. Palmer, proprietor of the Waltham School of Horology, Waltham, Mass., does quite a business in fine repair work and difficult horological jobs generally, for which his talents and experience render him well fitted. Any of our readers who have a "puzzler" are advised to send it to Mr. Palmer.

—On Sept. 20, Joseph Lennon, a young man, 20 years of age entered the store of the Spencer Optical Company, and after walking about for some moments, was seen by a clerk in B. L. Strasburger & Co.'s office, at the back, to leave, taking with him a package of goods from a case in the front part of the store. He was chased and captured up stairs at No. 15 Maiden Lane. He was arrested and sentenced to five months imprisonment.

—The Geneva Optical Co., 23 Washington st., Chicago, Ill., have recently issued a very full catalogue of their goods consisting of optical goods of all kinds, barometers, thermometers, etc. The Company are manufacturing a most complete line of trial cases, test types, etc., of the finest description as they cater to the first-class trade. Heavy demands are being made upon their repair and prescription department, in which special care is taken to accommodate patrons and customers.

—Waterman & Lehmann, 37 Maiden Lane, New York, manufacturers of diamond jewelry, have applied for letters patent for a new ear wire, for which are claimed the following advantages: that it will sit close to the ear, will not tip over, cannot get lost out of the ear, and that it can be easily put in and taken out the ear. The advantages make the invention a valuable one, and as the patentees are men of experience, we may presume that all that it is claimed for it. Though on the market but a fortnight, a considerable number of orders have been received, and a general satisfaction in its properties is being manifested.

—The "Argyll" and "Scroll" patterns of spoon work in sterling silver displayed in the announcement of the Towle Manufacturing Co., Newburyport, Mass., on another page, are hand engraved and quite different in character from the usual productions in this line—in fact unique. It is unnecessary to expatiate on the beauty of these designs and the excellence of their workmanship. The productions of this company are too well known to contain these qualities to require the fact to be repeated. The "Argyll" and "Scroll" are thoroughly new, the former having been patented on Sept. 10, 1889, and the latter on Aug. 27, 1889.

—The stock of McCarty & Company, importers of fancy goods and bric-a-brac, 525 Broadway, near Spring street, New York, offers many special attractions to the dealer in search of Fall novelties. Among these may be mentioned a choice assortment of entirely new Bisque figures; Meisen china, decorated and mounted in real bronze, silver and gold, (notably rare jewel boxes); mounted Villeroy, one of their specialties; banquet lamps, breiber bisques for wedding presents, a very inexpensive ware; and a variety of beautiful pieces of Italian silverware, including mirrors, boxes, vases, etc. All of these goods are this season's purchases; nothing is carried over, and almost all of them are specialties with the house.

—The demand at present for piano lamps amounts almost to a craze, to meet which the Bradley & Hubbard Mfg. Co., 29 Park Place, New York, have added this season several very elegant and artistic styles to their line. Remarkable to note are the wonderfully light and graceful combinations that are effected. These beautiful objects are made in silver finish, bronze, copper and wrought iron. Another popular fad in polite society is the "five o'clock tea," which is made in heavy, solid metal, principally copper, and is very tastefully designed. Besides these handsome wares this company have at their extensive showrooms an assortment of metal articles, from which any desired selection can be made.

—Charles F. Irons, manufacturer of gold, silver and plated society goods, Providence, R. I., announces in a handsome circular to the trade, that he has now ready to ship at the low price of \$2 each, the official badge for the 24th triennial conclave of the Grand Encampment of the United States, to be held in October. The design of the badge consists of the cross of Saturn, on which is laid the temple cross, and on the four arms are represented in appropriate enamel the Commandery badges of the four commanderies who are the host on the occasion. The badge is gold plated, finely enameled, artistically engraved and enclosed in a neat box, with a copy of the certificate on the cover issued by the triennial badge committee certifying it to be their only official badge.

—The Pairpoint Mfg. Co. manufacturers of fine gold and silver plated ware, are about to issue their new catalogue which will be the largest and completest they have ever prepared. The excessive demand for their goods, compelling night work, and their policy to produce as extensive and varied lines as large forces of workmen, copious working space, and the desire to supply any taste for higher classes of plated ware, can perform, necessitates this more than usual large catalogue. The company's New York Office at 20 Maiden lane, is resplendent with novelties just arrived. Exquisitely designed flat ware, fish knives and forks, new styles of sugars, peppers, and salts, cigar bottles and other small wares, lamps, and staple articles newly designed are displayed on all sides.

—At the regular meeting of the N. Y. Jewelers' Board of Trade' on Sept. 10, the selection of Daniel F. Appleton and Charles L. Tiffany as representatives of the watch and jewelry trades, on the committee of the world's fair, was endorsed and secretary Condit sent Mayor Hugh J. Grant, the following communication:

NEW YORK JEWELERS' BOARD OF TRADE, }
41 AND 43 MAIDEN LANE, }
NEW YORK, Sept. 11, 1889. }

Hon. HUGH J. GRANT, Mayor of the City of New York:

DEAR SIR.—At the regular meeting of the board of directors of this Board, held at these rooms, on the 10th inst, it was on motion, duly seconded and carried, *resolved*: "That the secretary notify Hon. Hugh J. Grant, of this city, that this Board of Trade heartily endorses his selection of Daniel F. Appleton and C. L. Tiffany, as representatives of the jewelers' interests on the committee of the world's fair."

In compliance with the above resolution I hereby respectfully advise you of the same. Yours very respectfully,

H. H. CONDIT, Secretary.

The following reply has been received by Mr. Condit:

MAYOR'S OFFICE, CITY HALL, }
NEW YORK, Sept. 12, 1889. }

DEAR SIR.—The Mayor directs me to acknowledge the receipt of your communication of September 11, inclosing the kind resolution of the New York Jewelers' Board of Trade. The Mayor is greatly gratified by the New York Jewelers' Board of Trade, and desires to thank its members through you for it, and for their kind interest in the exposition. Respectfully,

W. MCSPEER, Secretary.

H. M. CONDIT, Esq.,

Secretary New York Jewelers' Board of Trade.

LEON J. GLAENZER,

No. 80 Chambers Street, New York,

CLOCKS, BRONZES, PORCELAINS.

THE LARGEST LINE, THE NEWEST STYLES AND MOST SALABLE STOCK
OF ABOVE GOODS IN THE COUNTRY.

Paris House, 35 Boulevard Strasbourg.

ESTABLISHED 1838.



Artistic * Metal * Workers.

STERLING SILVER NOVELTIES ⁹²⁵/₁₀₀₀ FINE,

FINISHED IN CHASED, ETCHED, APPLIED AND ENGRAVED PATTERNS.

- | | | | |
|------------------|---------------|-----------------|----------------------|
| Bracelets, | Charms, | Cloak Clasps, | Spectacle Cases, |
| Bookmarks, | Colognes, | Collar Buttons, | Eye Glass Cases, |
| Belt Buckles, | Pin Cushions, | Cuff Buttons, | Court Plaster Cases, |
| Bon Bon Tongs, | Chatelaines, | Link Buttons, | Cigarette Cases, |
| Bonbonnieres, | Vinaigrettes, | Locks and Keys, | Card Cases, |
| Glove Fasteners, | Nail Files, | Tablets, | Match Boxes, |
| Shoe Fasteners, | Ink Erasers, | Fob Chains, | Safety Pins, |
| Garter Buckles, | Shoe Hooks, | Key Chains, | Crochet Needles, |
| Corn Knives, | Glove Hooks, | Vest Chains, | Pocket Combs, |
| Cuticle Knives, | Gantelines, | Queen Chains, | Ointment Boxes. |

NEW DESIGNS In Berry Spoons, Coffee Spoons, Sardine Forks, Butter Knives, Cake Lifters, Cheese Scoops, Sugar Shells, Salts, Peppers, Tea Strainers, Baby Rattles, Etc.

Special Order Work Carefully Executed for the Trade.

Watch Case Decoration a Specialty.

LEWIS BROTHERS,

41 & 43 MAIDEN LANE, NEW YORK.

—The factory of the Waterbury Watch Co. is under good headway, turning out about 1,000 watches a day, of both the short and long wind. A more ship-shape and better systematized factory cannot be found in the whole country, and the management are always ready to receive visitors.

—Nearly eighteen hundred hands are now employed in the Dueber-Hampden works at Canton, Ohio, on the site where only three years ago was harvested the largest crop of wheat ever cut on the same land. The crop this year will be about four hundred watches and two thousand watch cases per day.

—Among the more beautiful exhibits at the St. Louis Exposition, now in progress at St. Louis, Mo., is that of the Non-Magnetic Watch Co., which is under the supervision of Robert S. Hubbell, the company's western representative. A full assortment of all grades of their celebrated watches is displayed.

—The new 6,000-lamp electric light plant at the Elgin factory is now in running order. An electrical exchange says that the plant is the largest of its kind in the world. The light building is being handsomely decorated inside, and a maple floor is being put over the pine flooring, thus making the building very pleasing to the sight.

—W. A. Moore, manager of the Dueber and Hampden companies, is deeply interested in the coming exposition and celebration of 1892. For local reasons he favors Chicago, and in the event of the exposition being held in that city, it is proposed to organize jewelers' parties in the East to stop *en route* at Canton and inspect the factories.

—Watch factory boomers are endeavoring to induce the Board of Trade of St. Joseph, Mo., to start a watch factory, but their Utopian overtures do not seem to make any favorable impression, and there is no immediate fear of the organization of such an enterprise. The boomers' proposition included a bonus of cash and real estate to the amount of \$80,000—exorbitant for such a manufacturing plant.

—The Keystone Standard Watch Co., Lancaster, Pa., are about to place on the market three new movements—two 18 size and one 6 size. The former are 7 and 10 jeweled respectively and the latter 7 jeweled. These are to be followed by 11 and 15 jeweled movements of the same size. The superintendent, H. J. Cain, is introducing a new system throughout the factory, which is productive of good results.

The Non-Magnetic Watch Co., are contemplating the erection of an extensive factory for the manufacture of 18 size movements as the demand for these movements exceeds the Company's ability to supply them, and arrangements for their manufacture by other companies is not advantageous. The location is not yet decided upon; several cities hold out inducements which are under the consideration of the company.

—Seth Thomas tower clocks are still in good demand. The company recently shipped to Honduras one with a peal of bells to strike the hours and quarters, and have on hand orders for a tower clock for India, a clock to strike the hours and half hours for Paita, Peru, a striking clock for Superior, Wis., and a street clock for Kalamazoo, Mich. This company's general business, including watches, is unusually lively for this season of the year.

—The reduced prices of the New York Standard watches have increased the already good demand for them and bulky orders from Association jobbers are quite regularly received. Complete open faced watches in special white metal cases (not plated) are reduced to \$3.75 for snap back and bezel, and \$3.90 for hinged back and bezel, allowing a good margin to the retailer when sold at \$5. Retailers by sending for a sample watch, No. 13 or No. 14, will benefit their own interests.

—The Cheshire Watch Co. have just placed on the market the "new Cheshire" in a beautiful solid gold case, plain and designed, and orders already are far ahead. A lively trade is still being done in the "new Nickel," and the company's 18-size hunting, Nos. 21 and 25 are having an especially good sale. Changes at the factory, enlarged train room and an enlarged plate room, have increased the daily product by from 75 to 100 watches, and altogether the future for the company is bright.

—The affairs of the Aurora Watch Co. are in a better shape than is generally understood by the public. Supt. J. H. Weber writes that "the factory is being run as usual by the assignee, Senator H. H. Evans, and there is good reason to believe that the business will be arranged so that the Company will be put on a substantial basis in the near future." The inventory showed the actual assets, including finished movements deposited with banks as collateral, to be \$366,839.37; total liabilities, \$290,019.73

—The Trenton Watch Co's. new watch No. 25, with hard enamel dial and in open face nickel case with double joints and thumb pieces is having a large sale and is in great favor with watchmakers desiring a low priced watch that can be depended on.

—The new machinery for the Otay watch factory, Otay, Cal., has been received, and all the lathes at the factory are running, and the business of tool making is now being pushed forward ready for the more immediate work on the construction of watches, a model of which has been completed. A number of expert mechanics have been secured and are now at work. Local help will gradually be introduced under the instruction of more advanced operators, and under the supervision of P. H. Wheeler, of long and successful experience.

—The new 1889-1890 catalogue of the Wm. L. Gilbert Clock Co., issued last month, is a handsome affair. The paper and letter press are of the finest quality, and the excellent press work displays the beauties of the numerous designs illustrated to best advantage. Special attention is called to the new patterns in walnut, oak and plastic marble clocks, of which a goodly number are illustrated. In addition several new regulators, octagon drops, calendars, nickels, cuckoos and other clocks, as well as a number of sets, side pieces, top pieces and other bronzes are depicted. A portrait of Wm. L. Gilbert occupies a front page, and the cover displays a complete and handsome view of the works.

A report was in circulation last month that the Columbus Watch Company had decided to move their works to Salem. This rumor was generally denied by the company though they had received from two large cities offers containing liberal inducements. The company desire to increase the capacity of their plant, and to do this it is necessary to increase the capital stock from \$200,000 to \$400,000. The company claim that they can borrow all the capital they want but do not desire to do so; they want men to invest money in it permanently. The capacity has been gradually increased since its foundation until now about 160 watches are turned out daily. At present all the orders cannot be filled, the capacity of the works being insufficient. The directors have stated the situation to a number of Columbus capitalists, but have not received much encouragement.

In the handsome showrooms of the F. Kroeber Clock Co., at 360 Broadway, New York, is displayed in addition to their regular stock of artistic clocks and bronzes, a line of goods, cheap, salable and bought with especial reference and adapted to the fall and holiday season, which will prove of particular interest to every retail dealer. Bisque figures in rich colors, (from 75 cents up) small automatic and mechanical clocks, hand painted bonbonnières, mantel ornaments, and bric-à-brac, terra cotta statuettes, mirrors, real Berlin bronzes, etc., abound in profusion; the variety of marble and French onyx clocks with American movements, is almost endless. The Company issued last month a supplementary catalogue of new designs of imported marble cased (American movements,) enameled iron and other clocks, and several patterns not illustrated in 1888 '89 catalogue. Beautiful are their combination figures and clocks of bronze on an enameled iron base. This catalogue together with separate price list can be had upon application. A circular received by us contained some handsome new designs in French onyx clocks with American movements.

—The *Watchmaker, Jeweler and Silversmith*, quoting Ambrose Webster, of the American Watch Tool Co, gives the following interesting table:

Factory.	Value of Plant.	Daily Output.
American Waltham.....	3,000,000	dols. 1,500
Elgin National.....	3,000,000	" 1,500
Illinois.....	1,000,000	" 600
Waterbury.....	500,000	" 1,000
Hampden.....	400,000	" 200
Seth Thomas (watches only).....	150,000	" 100
Trenton.....	200,000	" 200
New York Standard.....	150,000	" 150
Cheshire.....	150,000	" 150
Manhattan.....	100,000	" 125
Keystone.....	100,000	" 100
United States.....	100,000	" 50
Peoria.....	100,000	" 100
Columbus.....	150,000	" 125
Aurora.....	150,000	" 100
Rockford.....	150,000	" 100
E. Howard.....	150,000	" 20
	<hr/>	
	9,550,000	6,115

TABLE OF CONTENTS.

Advice to Watchmakers' Apprentices..... 74	Foreign Matters..... 65	Mystic Jewels..... 50	Proceedings of the Watchmakers' and Jewelers' Union..... 82
Around Boston..... 53	Gossip of the Month..... 33	New Safety Watch Bow..... 81	Providence Notes..... 50
Attleboro, The..... 105	How to Drill a Staff..... 90	New Free Escapement..... 78	Quaker City, The..... 105
Chicago Briefs..... 66	How to make a Swiss Barrel Bridge..... 93	New Compensated Clock Pendulum..... 77	Recent Patents..... 97
Communications..... 106	Jewelers' League, The..... 78	New York Jewelers' Association..... 104	Stark's Mainspring Winder..... 98
Complete History of Watch and Clock Making in America—Chronometer Makers 101	Jewelers' Security Alliance..... 92	New York Jewelers' Board of Trade..... 98	Suitable Engine for Jewelers..... 98
Dr. Wells' Patent Eye Glass..... 81	Jewelers' and Tradesmen's Company, The..... 145	Northwest, The..... 70	To Pivot a Staff, etc..... 93
Factory Clock showing Day's Production... 57	Last Glimpses of the Paris Exposition..... 38	Obituary—William M. Weil—Julius Lange—Henry Horwitz..... 106	Trade Gossip..... 113
Fashions in Jewelry..... 77	Paris Awards..... 46	Our Round Table..... 82	Among the Watch and Clock Companies, 121
Art Glass and Ceramics..... 61	Mechanical Ocular Defects..... 89	Paris Gossip..... 49	Workshop Notes..... 94
Foreign Gossip..... 73	Manufacturers in Japanese Prisons..... 90		

INDEX TO ADVERTISERS.

Aby, Chas. Leo..... 64	Falkenau, Oppenheimer & Co., Outside bk cov.	Mathey Bros., Mathez & Co..... 2	Shiebler, Geo. W..... 56, 102 & 103
Aikin, Lambert & Co..... 79	Floyd, Pratt & Rounds..... 87	Mauser, Frank & Co..... 21	Smith & Knapp..... 80
Alvin Mfg Co..... 100	Foley, John..... 71	McCall & Newman..... 80	Smith, Alfred H., & Co..... 35
American Horological Institute..... 100	Foley, D. F. & Co..... 108	Meriden Britannia Co..... 8	Smith B. & W. B..... outside back cover
American Waltham Watch Co..... 72	Foster & Bailey..... 39	Merritt, S. F..... 26	Smith, H. M. & Co..... 88
American Watch Tool Co..... 92	Fowler Bros..... 43	Middletown Plate Co..... 3	Special Notices..... 125
Ansonia Clock Co..... 23	Fox, M. & Co..... 84	Miller, Edward & Co..... 63	Spencer Optical Mfg Co..... 13
Arnstein Bros & Co..... 28	Fradley, J. F. & Co..... 36	Miller Bros..... 47	Stark, John..... 26
Atkinson Bros..... 95	French, J. H..... 52	Moore & Horton..... 80	Sterling (The) Company..... 4
Atwater, William H..... 47	Friedlander, R. & L..... 29	Morse, Mitchell & Williams..... 23	Stern & Stern..... 31
Baird, Henry Carey & Co..... 115	Froelich, H. & Co..... 28	Muller's Sons, Nicholas..... 2	Stockwell, E. R..... 80
Ball, Wm. H. & Co..... 24	Fuchs, Ferd. & Bro..... 88	Myers, S. F. & Co..... Inside Back Cover	Straus, L. & Sons..... 60
Barrows, H. F. & Co..... Outside Back Cover	Geneva Optical Co..... 19	N. Y. Watch Case Spring Co..... 125	Sussfeld, Lorsch & Co..... 84
Bartholomew & Peckham..... 131	Gorham Mfg. Co..... 32	Newman, Louis, Jr..... 131	Talnier & M. Alpine..... 76
Bawo & Dotter..... 40	Haldimann, E. A..... 28	Nissen, Ludwig, & Co..... 79	Tannenbaum, L & Co..... 56
Beguelin, Tell A..... 124	Hartford Silver Plate Co..... 19	Non-Magnetic Watch Co..... 44	Taylor & Bro..... 55, 56
Bedichmer, I..... 115	Haskell, H. C..... 100	Noterman, Jos. & Co..... 92	Ternendf, F..... 131
Berlin Demagnetizer Co..... 30	Hausburg, O. E..... 131	Nye, Wm. F..... 27	Thurnauer, G. M..... 27
Birch, John S., & Co..... 124	Hawkes, Thomas G..... 43	Odenheimer & Zimmern..... 132	Todd, Ed. & Co..... Outside back cover.
Blancard & Co..... 76	Hearn & Braltsch..... 24	Oppenheimer Bros. & Veith..... 60	Towle Mfg Co..... 9 to 12 & 87
Bonnet, Jacob N..... 28	Hedges, A. J., & Co..... 79	Oppenheimer, Henry E. & Co..... 51	Trenton Watch Co..... 116
Bookhout Bros..... 131	Hedges, Wm. S. & Co..... 75	Ostby & Barton..... 91	Troemner, Henry..... 131
Bowden, J. B., & Co..... 71	Heinrich, H. H..... 88	Owen, G. S., & Co..... 56	Ullrich, J. L. & Co..... 23
Braxmar, C. G..... 131	Herring & Co..... 107	Pallard, M. J. & Co..... 115	United States Watch Co..... 35
Bradley & Hubbard Mfg Co..... 83	Hollinshead Bros..... 83	Pairpoint Mfg Co..... 6	Valentine, D..... 81
Bryant, M. B. & Co..... 108	Howard, S. P..... Outside back cover	Peterson & Royce..... 95	Valuable Instruction Books..... 29
Buhler & Nanz..... 95	Hyde's Sons John E..... 92	Pforzheimer, Keller & Co..... 30	Wade, Davis & Co..... 86
Bynner, T. B..... 131	Imhauser, E..... 131	Pinnell, May & Co..... 71	Waltham School of Horology..... 115
Carter, Sloan & Co..... 59	Jackson, S. C..... 130	Pinover, A. & Co..... 57	Waltham Watch Tool Mfg. Co..... 29
Cattelle & Decker..... 95	Jacot & Son..... 63	Plainville Stock Co..... 96	Wallace, R., Sons Mfg Co..... 55
Chalmers-Spence Co..... 52	Jacques, Charles..... 1	Pratt, Chas. S..... Outside back cover	Want, Edwin..... 23
Champanois & Co..... 76	Kahn, L. & M. & Co..... 24	Pratt, Chas. D. Co..... 120	Washburn & Moen Mfg. Co..... 131
Chicago Horological Institute..... 64	Keller, L. H. & Co..... 124	Prindle & Russell..... 76	Washburne, E. G. & Co..... 27
Clark, A. N..... 92	Kendrick & Davis..... 52	Racine Jewelry Mfg. Co..... 25	Watchmaker, Jeweler and Silversmith..... 124
Conover, D. F. & Co..... 17	Kent & Stanley..... 26 & 91	Randel, Baremore & Billings..... 112	Waterbury Clock Co..... 1
Cooke, B. J's. Sons..... 92	Ketcham & McDougall..... 100	Riley, John A..... 64	Waterbury Watch Co..... 111
Cottler, C. & Son..... 131	King, Julius, Optical Co..... 6	Riley & Osborn Mfg. Co..... 2	Waterman & Lehmann..... 123
Cottle, S. Co..... 68	Kluber, S. & Co..... 24	Robert, J. Eugene, & Co..... Two inserts	Well, Maurice..... 115
Cralle, J. B. & Co..... 125	Klingenberg, A..... 96	Rogers & Bro..... 7	Welch & Miller..... 52
Crescent Watch Case Co..... 72	Koch & Dreyfus..... 88	Rogers & Hamilton Co., The..... 51	Wheeler, Hayden W. & Co..... 60
Cross & Beguelin..... 23	Kohlhusch, Charles..... 131	Rogers, Smith & Co..... 20	Whiting Mfg. Co..... 119
Crouch & Fitzgerald..... Outside back cover	Kremenz & Co..... 69 & 123	Russell, Irving L..... 100	Whiting, F. M. & Co..... 16
Cummings, Josiah & Son..... 132	Lapierre, F. H..... 29	Russell & Jones Clock Co..... 99	Wiggers & Froelich..... Ins de Back Cover
Day & Clark..... 20	Lapp & Flershem..... 18	Sartorius, A. & Co..... 131	Wilkinson, C. B..... 131
Didisheim, Hipp..... 84	Laurentot, J. B..... 132	Sauter, L. & Co..... 84	Woglom, Gilbert T..... 8
Dorflinger, C. & Sons..... 36	Lawson & Van Winkle..... 100	Schleicher, Schumm & Co..... 50	Wood & Hughes..... 56
Dreyfus, Henry, & Co..... 15	Lelong, L. & Bro..... outside back cover	Scheldig, John & Co..... 28	Wood, Chas. F..... 76
Dueber Watch Case Mfg. Co..... 14	Lewis Bros..... 108	Scott, J. T. & Co..... 48	Wood, J. R., & Son..... 131
Elliott, Geo. & Co..... Inside back cover	Logan, A. J..... 22	Seth Thomas Clock Co.,..... Inside front cvr	Zimmern, Henry..... 130
Essex Watch Case Co..... 99	Lorsch, Albert, & Co..... Outside back cover	Sexton Bros. & Washburn..... 96	Zineman, M. & Bro..... 84
Evans, W. F. & Sons..... 52	Marcy, F. I. & Co..... 71	Sheafer, W. II., & Co..... 56	

REDUCTION IN PRICES

Of many lines of our goods from July 1st.

JULIUS KING OPTICAL CO.,

4 MAIDEN LANE,
NEW YORK.

CLEVELAND,
OHIO.

WE ARE now manufacturing the finest and most complete set of TEST LENSES in the world, all coned and accurately focused. Our instructions regarding the CORRECTION of the DEFECTS OF VISION are PLAIN and PRACTICAL, and are of more value than the price asked for the OPTICIAN'S OUTFIT.

Don't Purchase until you have examined our ELITE SET.



We are the Sole Agents for JUDGE MACK'S CELEBRATED OPERA GLASS HOLDER. Prices Reduced.

PAIRPOINT MANUFACTURING CO.,

NEW BEDFORD, MASS.,

FINE GOLD AND SILVER PLATED W. RE.



No. 2628.-- Iain Gold Lined, \$4.25.



No. 3550.--Lunch Set.

The Largest Line of Novelties of Wedding and Holiday Presents on the market.

SOMETHING NEW EVERY DAY.

CATALOGUES ON APPLICATION.

20 Maiden Lane, 90 & 92 Wabash Ave., 220 Sutter St., Sydney,
NEW YORK. CHICAGO, ILL. SAN FRANCISCO, CAL. AUSTRALIA.

Readers, Please Mention **THE JEWELERS' CIRCULAR** When Writing or Buying.



VOLUME XX.

NEW YORK, NOVEMBER, 1889.

No. 10.

THE JEWELERS' CIRCULAR

AND

HOROLOGICAL REVIEW.

OFFICIAL REPRESENTATIVE OF THE JEWELERS' LEAGUE, THE NEW YORK JEWELERS' BOARD OF TRADE, AND THE JEWELERS' SECURITY ALLIANCE.

It is also the Recognized Exponent of Trade Interests.

A MONTHLY JOURNAL DEVOTED TO THE INTERESTS OF WATCHMAKERS JEWELERS, SILVERSMITHS, ELECTRO-PLATE MANUFACTURERS, AND THOSE ENGAGED IN THE KINDRED BRANCHES OF ART INDUSTRY.

SUBSCRIPTION.—To all parts of the United States and Canada, \$2.00 per Annum, Postage Paid. To all Foreign Countries, \$3.00 per Annum, Prepaid.

All communications should be addressed to

THE JEWELERS' CIRCULAR PUBLISHING CO.,
189 BROADWAY, NEW YORK.

Advertising rates made known on application.



A full Index to Advertisements and Table of a Contents will be found on Page 5 of this issue.

THE association known as the Wholesale Jewelers' Protective Association, which has been organized by the jobbing jewelers of the whole country, to protect themselves and their customers, the retail jewelers, from the unfair competition of dry goods and notions stores, proceeds upon the most broad and liberal principles and has no intention of boycotting anybody. The jobbers simply combine together and exercise their collective right to purchase goods from such manufacturers as will protect the interests of the jobbing and retail trades by refusing to sell the retail dry goods stores at unfair discounts. The association recognizes the indisputable right of every manufacturer to sell to whom he pleases; it also asserts its own indisputable right to buy of whom it pleases. The evils which it is designed to correct are becoming more grievous every day. Large notions houses in New York, Chicago and other cities send out illustrated catalogues broadcast over the land. These catalogues contain cuts of jewelry with prices attached. The receiver of one of them at once determines upon investigating prices, and sets out for a jewelry store where similar articles are priced, and the difference, of course, found to be in favor of the catalogue house. The inquirer, who may be a customer of the jeweler, then tells him that he can get the same article so much less. He feels distrustful of the jeweler,

and ten chances to one ceases trading with him. The jeweler then complains to his jobber, and he, too, feels as though he had been unfairly treated. The jobber, in his turn, falls back on the manufacturer, who has thus allowed his goods to get into outside channels, and there is general dissatisfaction and loss.

* * * * *

ANOTHER evil is found in the bogus export houses that buy jewelry ostensibly for export at a discount of 10 per cent. or so under current wholesale rates, and immediately bill the goods to some large dry goods or notions house, thus clearing a nice percentage by a mere turn of the hand. There is no good reason why manufacturers should sell to exporters at lower rates than to their other customers, especially when the effect is seen to be so disastrous to the interests of the whole legitimate trade.

* * * * *

THE case presents itself in this way: The jobbers find their interests and those of the retail trade firmly bound together. Both suffer from the ruinous competition in question. The jobbers have taken the initiative in the matter, and the retail trade is behind them. Manufacturers who sell the retail trade and wish to retain the wholesale will be expected to sell at prices that will protect the jobber, whether he be exclusively a jewelry jobber or a fancy goods jobber, it matters not so long as a just schedule of prices is maintained, and the dividing line is drawn on the principle that one who buys to sell to another dealer is entitled to closer rates than one who buys to sell to the general public. One consideration which should influence the manufacturer in deciding this matter for himself is that the fancy goods trade is constantly crying for novelty while the jewelry trade demands more staple goods. This effects a great saving to the manufacturer in the outlay required for dies, which constitutes a considerable portion of the cost of a manufacturing jewelry business.

* * * * *

TO SHOW the sources of information possessed by the new association, we may remark that some time ago there appeared in the New York papers an advertisement for a salesman to take charge of a jewelry department in a notions store. Quite a number of applicants responded, and nine out of ten of them were pumped dry, as they showed a perfect willingness to tell all they knew about their business. This little incident is sufficient to give an idea of the avenues of information that lie open to the association whenever it chooses to avail itself of them. The movement has met with a prompt response from the jobbing trade of the entire country, and if the liberal and conservative spirit of its promoters is preserved throughout, it is safe to predict a successful history for it. The retail trade should give this new power in the trade the attention its purposes and strength demand. We should state, in closing, that the Wholesale Jewelers' Protective Association is in no way con-

nected with the National Association of Jobbers in American Watches.

* * * * *

"Last Glimpses of the Paris Exposition," page 38.

* * * * *

SUBSCRIPTIONS for the World's Fair of 1892 will now be in order. The Jewelers' Association has been appointed agent of the Finance Committee for the jewelry trade, and the books have been opened at the rooms of the Association, 142-146 Broadway. The Gorham Co has also been appointed to receive funds. It is to be hoped that a liberal response will be made, so that the jewelry interest will make as creditable a showing in the organization of the Fair, as it undoubtedly will at the Fair itself.

* * * * *

AS ILLUSTRATING the difficulty of enforcing laws for the regulation of trade and commerce, however beneficent they may be, it is worth while to cite an instance of the evasion of the English Hall Mark Act that has recently come to light. The Prescott watchmakers complain that an immense number of foreign watch movements are secretly being brought into England from Switzerland, put into English hall-marked cases and then palmed off as of English manufacture. Foreign competition is one thing; palming off foreign goods as articles of English manufacture is quite another and the Prescott watchmakers have good reason to complain of such a fraud upon the public. The alleged conduct of these importers is clearly a violation of the spirit of the Merchandise Marks Act, as the law requires that imported manufactures shall be clearly marked with the name of their place of origin. The movements are doubtless so marked, but the marking is to little purpose if it is possible so to enclose these portions of a watch in English hall marked cases that the indication of the place of origin is kept out of sight. If the Vigilance Committee who have been appointed by the Prescott watchmakers should find the existing legal remedies insufficient, it is probable that the Merchandise Marks Act will be amended.

* * * * *

See our "Horological School Notes," a new department.

* * * * *

THE Committee of the New York Board of Trade and Transportation on bankruptcy legislation, presented a report to the Board last month endorsing the Torrey Bankrupt Bill and recommending its passage by the next Congress. Other commercial bodies throughout the country have given similar endorsements, notably the general convention of mercantile bodies of the United States held in Minneapolis on September 4 of this year. Judging from this singular unanimity of approval the Torrey Bill represents the views of the leading merchants of the land. This being so clearly demonstrated there is every reason to believe that Congress will take favorable action upon it at an early day, thus removing the conflicting and abstruse bankrupt laws that now constitute one of the greatest causes of annoyance and loss the merchant has to contend against.

* * * * *

Complete List of all Awards at the Paris Exposition, of Interest to the Trade, page 46.

* * * * *

THERE is great activity at present among the searchers for cat's-eyes in Ceylon. Crowds of Moormen have flocked to the gem districts. The recent finding of a stone weighing over six pounds is in part responsible for this. In Galle, a province of the district, a syndicate has been formed to carry on mining operations. The stones are found in the wash soil at a depth varying from 12 to 16 feet. It is rumored that the finder of the large stone already men-

tioned declined an offer of £19,000 for it. However this may be, it is quite likely that the demands of cat's-eye fanciers will be satisfied as a result of all this digging and turning.

* * * * *

BUYERS of silver plated ware cannot be too often urged to place their orders in the fall early. The time required to properly fill orders for silver plate, particularly hollow ware, and the great improvement in finish obtainable by giving a little time for extra care, as well as the advantage to the merchant of two opportunities to sell his goods instead of one—all these considerations make it plainly for the interest of the buyer to order as early as possible. Unlike jewelry, silver plated ware is in most cases finished after the receipt of the order.

* * * * *

THE Mexican House of Representatives has passed a bill to offer lands free to negroes who will emigrate from this country to Mexico. The bill has been sent to the Senate, and it is believed that it will pass that body and be signed by President Diaz. The expectation is that in event of this bill becoming a law there will be an enormous exodus of negroes from the Southern states. What will become of the race question in the South then? And what will become of some of our politicians who have been making it their stock in trade?

* * * * *

"An American Critic on the Exposition and the Awards," under "Communications."

* * * * *

IT IS said that the Paris Exposition has given awards to 33,000 out of 60,000 exhibitors, so that the honor of getting an award is rather a doubtful one, to say the least. Some of the "medals" were given on paper only, as they will never be actually cast.

* * * * *

AMERICANS who have been accustomed to think that no good thing can come out of Nazareth in the jewelry and silverware line, will receive a rude shock to their prejudices in the awards at the Paris Exposition. As a result of the displays made there, it is confessedly the opinion of experts, foreign and native, that the United States is easily the peer of the world in these branches of art industry. While the nations of the old world have been making tardy progress, if any, our silversmiths and jewelers have moved with gigantic strides. They have studied successively all the known styles of the art, ancient and modern, thoroughly made them their own, improved upon them, and after assimilating them all evolved a manner of their own that is exciting the wonder and admiration of the conservatives abroad. Here, then, before all the world are our artisans crowned and decorated! How foolish it will be for us hereafter to take ship to Paris or London when we want anything choice in this line! Foreign jewelers have traded largely on the gullibility of the average wealthy American tourist. They have found him a convenient outlet for old stock that could not be palmed off upon their more fastidious customers at home; and while thus deprived by a foolish prejudice of the trade that was deservedly theirs, our artisans have worked heroically to turn the tide in their favor. Their success at the Paris Exposition is a complete vindication of their ability not only to equal the leaders on the other side, but even to surpass them in many respects. We sincerely hope that the press of the country will take it upon themselves to force home to the people this plain moral of the Exposition, and that we shall not in future have to complain of the diversion of so much of our aristocratic trade into the hands of European jewelers and silversmiths. The period of fadism and slavish imitation of foreign wares as such is about over. Our people are learning to judge for themselves in

matters of taste. The day of our bondage to Europe is ended. We should assert our independence in art as in other things.

* * * * *

Take a seat at "Our Round Table" and listen to the discussions of the evening, page 82.

* * * * *

THE recent attempt of the Société des Métaux and the Comptoir d'Escompte bank to corner the world's supply of copper, has ended most disastrously for the speculators. The French courts have condemned the directors of both institutions to penalties aggregating nearly \$5,000,000, on the ground that the contracts entered into were clearly in violation of the bank's charter and by-laws. This is the last and most crushing of the losses that have "huddled upon the backs" of the luckless speculators, and should put a stop to such ambitious attempts in France for some time to come.

* * * * *

UNDER "Our Round Table" will be found letters from two correspondents describing novelties in the advertising line that will be found useful to the retail jeweler. Every reader of THE CIRCULAR should carefully peruse this department every month, for the questions discussed at the meetings are sure to be of vital interest to him. He will gain information from it that can be obtained in no other way. Little suggestions such as these about advertising are of incalculable value to the wide-awake, pushing jeweler. They furnish suggestions and stimulate his own ideas to greater activity. It is our intention to give the widest publicity to the transactions of the Watchmakers' and Jewelers' Union, and to all communications that may be sent in on the subjects under discussion by that body. It is for the reader to take advantage of this opportunity for self improvement.

* * * * *

The First Chronometer Made in America, with cut.—Vide, "History of Watch and Clock Making in the United States."

* * * * *

THE junketing tour of the delegates to the Pan American Congress has occupied a good deal of the attention of the politicians and the press during the past month. These gentlemen must now be fully impressed with the bigness of the country and the bigness of the talk of our politicians. Of course, this swing around the circle is all preliminary to the real work of the congress, and it is impossible to tell yet whether it will be its most important achievement or not, but one thing is certain, the European nations who now possess the trade of the South American countries can well afford to let us spend lavishly in entertaining their customers so long as they do the business. There is just so much less of it for them to do. They know that the duty on raw materials which prevents those countries from exporting to us is their best friend. Hence they are perfectly unconcerned about this junketing tour, and the Pan American Congress with its prospects of subsidies and the silver unit, except in so far as it furnishes an amusing spectacle to the nations. The cry of the woolen manufacturers and the eastern iron manufacturers for free raw materials is much more ominous to them.

* * * * *

Call the attention of editors of your local papers to "Elsie Bee's Rambles Among the Jewelers," and have the items reprinted. It will increase your trade.

* * * * *

ALMOST simultaneously with the report of diamond discoveries in Kentucky, comes the rumor of the finding of rich diamond deposits in Mexico, in the district of Guerrero. The beds are said to be situated in a range of mountains known as the Coronilla, near

the village of Tepantitlaw, and the soil is described as argillaceous, with a plentiful supply of small stones. Rumors of this sort are becoming so common now as to excite little comment. Prices are still in the ascendant in the diamond market.

* * * * *

NEWS comes that a company of New York capitalists has been organized to build extensive works for the manufacture of aluminum, near Findlay, O., clay in abundance being found in that region. Other companies are being organized in various parts of the land to manufacture the new metal. Many of our famous chemists are busily at work on the problem of separating the metal from clay at a low cost. As yet no process has been announced, and many experimenters have abandoned the search as hopeless. Others still persevere, and the coveted process will in all probability be discovered ultimately. In the meantime aluminum is finding many uses in composition with other metals, particularly for spectacles and eye-glasses, where its lightness and ornamental appearance are highly prized.

* * * * *

Every wide awake jeweler has an optical department now-a-days, and ought to read our optical department, edited by Dr. C. A. Bucklin, M. D.—Vide, "Mechanical Ocular Defects," page 89.

* * * * *

AMONG other reported gem discoveries during the past month is that said to have been made at the Lincoln Mines, San Pedro, N. M., where a large cave sparkling with sapphires, gold and silver is said to have been unearthed. The dimensions of the cave are given as 100 feet by 50, and the floor is said to be thickly covered with boulders of carbonate. An offer of \$250,000 is said to have been refused for the mine, and great excitement prevails in the whole region. Nothing is said about the quality of the sapphires, however. Another sensational story comes from Birmingham, Conn., where a metal very closely resembling gold is reported to have been discovered by a gentleman of that place in the course of some experimental tests of other metals. Rumor has it that the new metal weighs about the same as gold, closely resembles it in color, can be manufactured at sixty cents a pound, is malleable, ductile and strong. It is stated that the color is imparted by the action of a chemical. Is it possible that the power of transmuting into gold, which the mediæval alchemists toiled for in vain, has been accidentally hit upon by a 19th century experimenter? The whole story has hardly emerged yet from the misty land of rumor, and, in any event, it is probable that the new metal can easily be distinguished from gold. It must, however, possess many qualities that will make it available in the manufacture of jewelry.

* * * * *

Read "Art Glass, Keramics and Bric-à-Brac," page 61, to learn the latest selling novelties in this line.

* * * * *

WE PUBLISH in this issue of THE CIRCULAR our "Last Glimpses of the Paris Exposition," together with a complete list of the awards to American exhibitors in our departments and a list of the principal awards to European exhibitors in the horological section. The communication on the Exposition by an American critic of experience who was on the ground at the time the announcements were made, and whose knowledge of the whole affair is from inside sources, will be read with great interest by the trade. In closing our account of the great World's Fair we cannot refrain from again bestowing the congratulations that have been showered upon our silversmiths from all sides for the originality and magnificence of their displays. They alone saved the country from utter insignificance at the Paris Fair of 1889. What will they do for us in 1892? Something eminently worthy, rest assured.

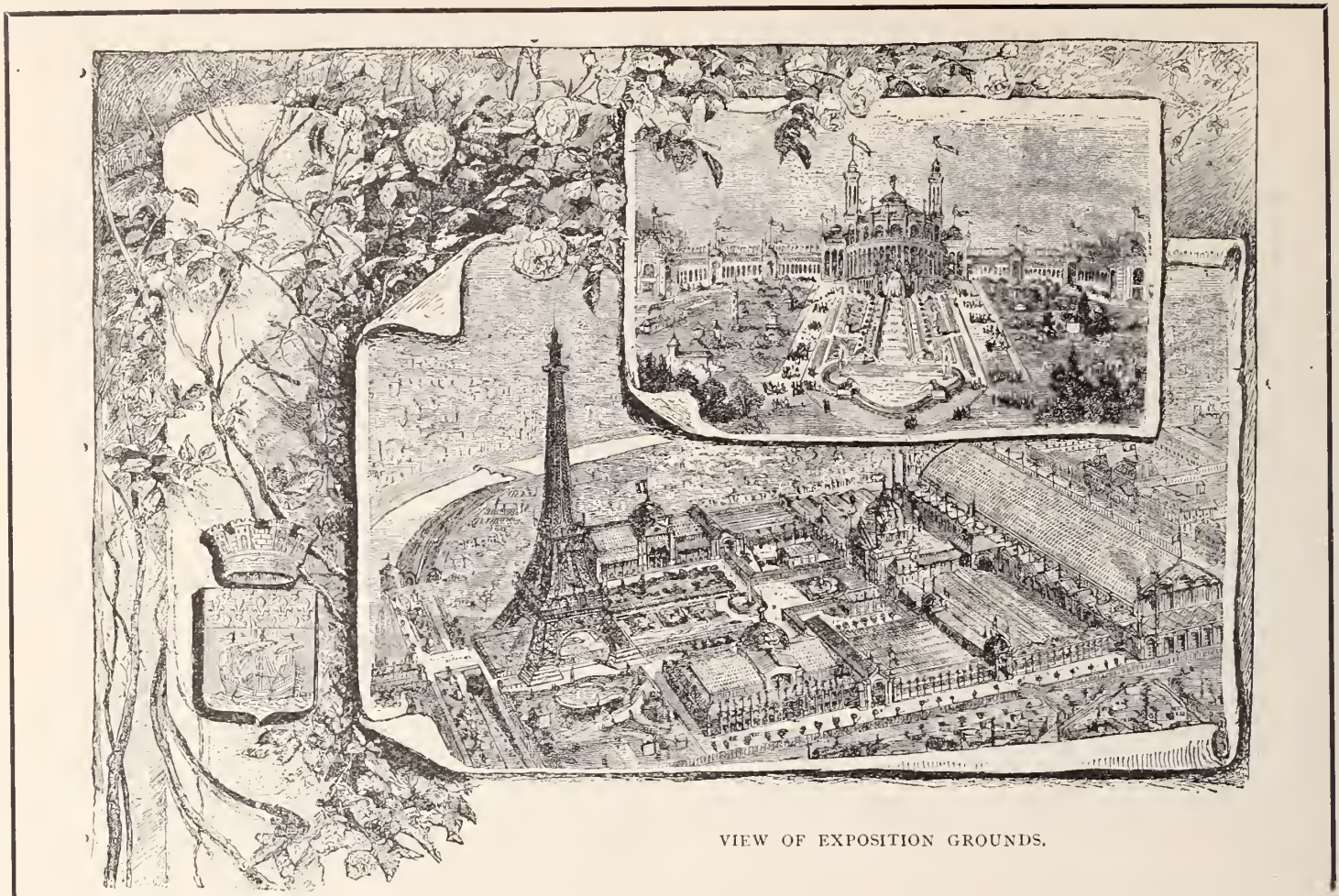

VIEW OF EXPOSITION GROUNDS.

Last Glimpses of the Exposition.

THE ROOKWOOD POTTERY AND T. G. HAWKES' CUT GLASS DISPLAY.—HISTORY OF THE ROOKWOOD POTTERY.—CUT GLASS IN AMERICA.—WATCHES FOR THE MILLION.—THE TRENTON AND THE WATERBURY.—HOW THE AWARDS WERE RECEIVED.—SOME PREVIOUS WINNERS.—DIAMOND CUTTING ILLUSTRATED.

PARIS, October 6th, 1889.

The Rookwood Pottery and T. G. Hawkes' cut glass (rewarded yesterday with a Grand Prix) have made of Davis Collamore & Co.'s exhibit one of the most attractive places in the whole Exposition. Their display, as shown in the illustration, is so beautifully and so cleverly arranged that one can obtain at a glance a thorough idea of its superior value. The entrance, of chocolate-colored wood, is adorned with red velvet hangings, and the glass cases on the side are in black wood, the whole being enlivened with a sober gilt rim. Davis Collamore & Co.'s exhibit has created a veritable sensation at the Paris Exposition. Many Americans hardly knew that glass or pottery were made at home, and the surprise to foreigners was still greater. This pottery has attracted the attention of manufacturers and collectors. Many choice pieces have been sold to museums, notably, to the Musée des Arts Décoratifs of Paris; the Musée Hongrois des Industries d'Art, of Buda-Pesth, Hungary; Nobuyoski Komai, of the Imperial Japanese Commission to the Exposition; the Worcester Royal Museum, of Worcester, England; and many other educational institutions, private collections, etc. Americans should feel proud of an industry which, with an existence of barely a decade, has been able to show to the people of the old world where the ceramic art has been nurtured and cultivated for ages, a product novel and original, and at the same time thoroughly artistic.

ORIGIN OF THE INDUSTRY.

The Rookwood Pottery Co. was established at Cincinnati, in 1880, by Mrs. Maria Longworth Storer, whose father, Joseph Longworth, was the founder of the Art School, and a chief patron of the Art Museum in the same city. The artistic impulse which inspired the venture came from the ceramic display of Japan at the Centennial Exhibition of 1876, and the production still bears the impress of that influence. For a time, a school for pottery painting formed part of the scheme, and, from the beginning, the commercial side of the enterprise has been subordinate to the artistic.

The ware is a true faience, made of clays from neighboring deposits in the Ohio Valley, while the decorators, with the exception of one native Japanese, and including the founder herself, are graduates from the local art school. The artists are encouraged to give to each piece an individual character, and, as no printing process is in use, duplications are seldom even attempted. After an early imitative period, these conditions, aided by the native inventive faculty and the ample capital at command, have developed an American pottery which possesses marked originality.

The coloring in both grounds and decorations is entirely under-glaze, and the production divides itself into three classes: "cameo," or shell-tinted ware, used for the table; "dull finish," whose surface while soft in texture, and easily cleaned, has the appearance of being unglazed; and, lastly, the most distinctive class of richly glazed ornamental work.

The distinguishing mark of Rookwood faience in all these classes is the decorative quality of the color grounds. Their harmonious blending is carefully studied with reference to the decoration, and to fine examples, especially of the darker toned glazes, their softness, depth and luster impart a rare beauty.

The cut glass divided the honors with the pottery. For many years the foreign articles had been the standard, and although (says

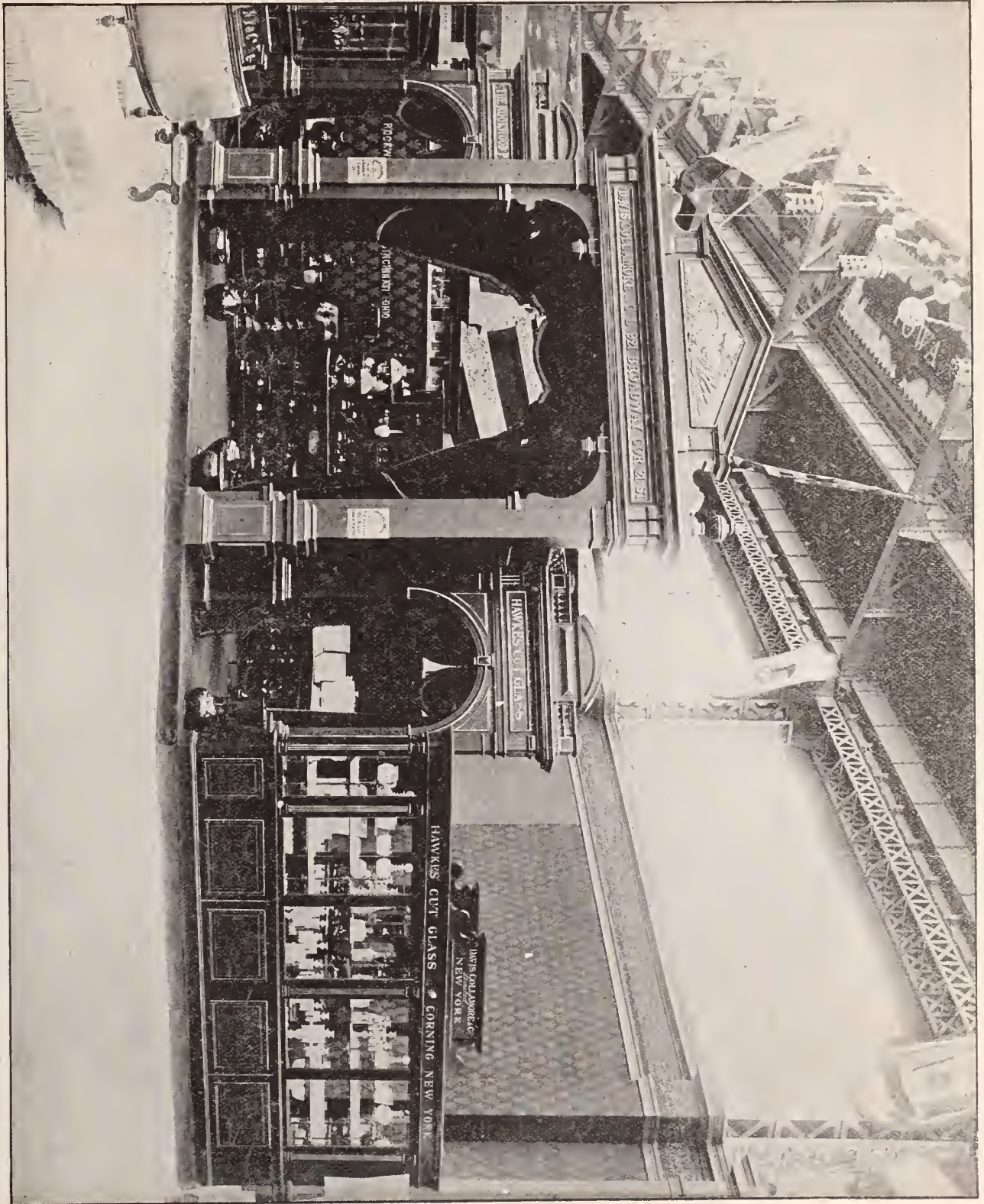

EXHIBIT OF DAVIS COLLAMORE & CO., SHOWING HAWKES CUT GLASS AND ROCKWOOD POTTERY.

Davis Collamore & Co.'s agent) for some time the United States has been producing a crystal as pure in color, perfect in cutting and finish, and unexcelled in design, as could be found anywhere, yet the

he cannot realize the fact. He hurriedly buys the article, thinking that he must at once profit by an evident mistake. The same thing occurs at the Waterbury depot, on the Boulevard Montmartre. The genius of enterprise never came to a full growth in our land or in the neighboring ones, and when we are told that the Waterbury Watch Co. produces 1,500 watches a day, a dizzy sensation comes over us. It is true that, even in a country like America, that may be considered something wonderful. A clear mind, however, will see at once that a machinery which goes steadily through such an amount of work must be backed up by an organization to match. Hence the (otherwise inadmissible) possibility of selling watches at so reduced a price, without running to ruin. A mere glance at the list of the Waterbury Co.'s depots will show that their watches are sold in every part of the civilized world; and I may add that they seem to have reconciled the most opposite classes, in winning the choice of the land owner as well as that of his tenant.

SUCCESSFUL COMPETITORS

You will not be surprised to hear that most American exhibitors: The Gorham M'fg Co., Tiffany & Co., The Meriden Britannia Co., Seth Thomas, Heinrich, Fairchild, etc., have obtained the highest awards. The Gorham M'fg Co.'s silverwares and Tiffany's jewelry will have proved up to the last very great favorites with the public. The Meriden Britannia Co. is considered unrivalled in the electroplate line, Fairchild pocket-wares have attracted all visitors



WORKS OF ART IN TIN.—JULES BATEAU.

old prejudice in favor of the foreign make, has lingered on, and has needed only such a practical demonstration as the Exposition to prove to the world that, in the matter of rich cut glass, you need not fear competition. The glass exhibited is manufactured by T. G. Hawkes, of Corning, N. Y., established the same year (1880) as the pottery, who, by producing only the best work, has to-day one of the largest cut glass establishments in the world.

Davis Collamore & Co., with an experience of nearly half a century as importers of pottery, porcelain and glass, were among the first to recognize the merit of domestic goods. The great success of their exhibit at the Paris Exposition, and the high awards they have received for the superiority of their goods will no doubt impart this belief to all American purchasers in those lines.

TRENTON WATCHES.

The Trenton Co.'s exhibit of watches is certainly one of the prettiest of that kind; the display is arranged on an hexagonal column covered with blue marine velvet. The public, fascinated by the elegance of the cases, so daintily adorned, and thoroughly captivated by the neat and strong appearance of the inside works, is soon conquered by the comparatively low prices. Anyone who can afford to purchase a good watch, is not always ready to pay a high price for it. Hence the well deserved success of the Trenton watches.

THE WATERBURY PYRAMID.

The Waterbury pyramid (see September number), is always a center of attraction. Placed outside the further entrance of the U. S. section, it stops the public, who gaze with the deepest surprise at those 2,996 watches so prettily arranged in a kind of ascending cone. The agents, always on the lookout, never fail to explain the qualities of the watches, whose price seems so low to a continental buyer that



DIAMOND VINE LEAF AND GRAPES.

and the Seth Thomas incomparable clocks have commended themselves to all experts in that line.

HOW EUROPEANS FARED.

In the Swiss section, Ernest Francillon & Co. received a Grand Prix, and Agassiz fils a gold medal. Great Britain's exhibits in our lines have not, on the average, been favored with very high awards. It is true that the Goldsmiths and Silversmiths' Co. obtained a gold medal, and the Silversmiths' Alliance a silver one, for their jewelry. But these two houses, as well as J. Dixon & Sons, only received a bronze medal for their silver wares. The members of the jury do not seem to have understood the special character of these goods which, although they may not suit all countries, answer the requirements of English customers.

In the French sections, several exhibitors have shown themselves very much dissatisfied.

SOME PREVIOUS WINNERS.

In the jewelry department where Vever and Boucheron have

HAND MIRROR BY VEVER.

One of the most lovely pieces in Vever's exhibit is a hand mirror. The exquisite frame is adorned with delicate foliage in chased green gold, set off by a yellow background, and circled with a row of pearls, divided by a gold ornament in the shape of a bean, or a flattened rattle-ball. On the top is a small shell in dead brown gold. The handle is of an original design, being formed of a mermaid or *fee aux perles*, in almost white gold. Her head, slightly turned on one side, is resting on a comparatively large shell in brown gold. The arms, gracefully uplifted, are playing with her hair, which is adorned with pearls. The finishing part of the body seems to belong to a sea monster, and the snake-like folds covered with scales of a changing color have a beautiful nacreous luster. The well-shaded pink pearl caught at the base is a dainty termination.

Boucheron's diamond vine leaf with a bunch of grapes is a thorough masterpiece of jewelry, which brings us closer to nature than anything he has hitherto attempted. It seems so real that the present illustration hardly shows the outlines of the stones it contains. The leaf chiefly consists of very large diamonds set with a very slight

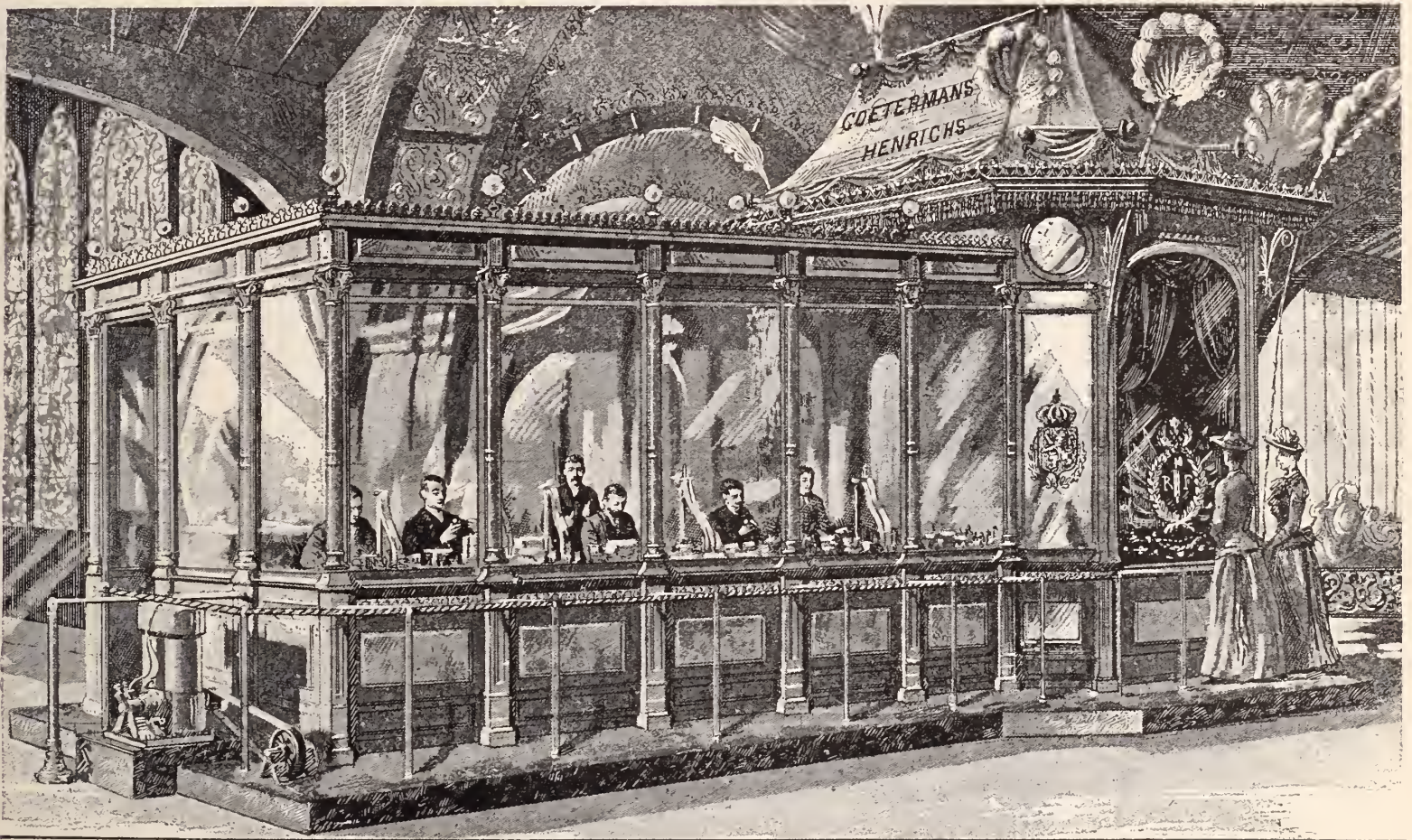

DIAMOND CUTTING BY COETERMANS HENRICH'S.

obtained the Grand Prix, it has been urged that the latter ought to have retired from competition, having received the highest rewards in 1878. I do think it would have been not only right but also advisable for him to do so, as, in spite of his important display of elaborate pieces, in the silver line, he only obtained a silver medal for it. The decisions of the jury seem to have been most submissively accepted by the French silversmiths. Yet, I must confess that I cannot understand why Christofle & Co., Fannière, and Froment Meurice were not considered *Hors Concours*, having obtained the highest awards to be had in 1867 and 1878. Although we have seen here and there a few remarkable novelties in their displays, most of the pieces exhibited by them were seen in previous expositions. It is really much too easy for them to carry off the great prizes.

relief, the main part of every stone being hidden underneath, at the back. The frame work shows all the nerves, dents and curves of the leaf to a nicety. The grapes are made in a way reminding us of the balls paved with diamonds, often used lately as hair pin heads. But in the present case, the brilliants are so tiny, and set so close together that, even at a short distance, it hardly looks granulous. This charming copy from nature is valued at \$24,000.

Jules Brateau obtained a gold medal for his tin works of art. The ewer, reproduced here, is a copy of Francois Briot's celebrated one preserved at the Musée de Cluny. It is covered with elegant arabesques. The prominent part is adorned with three medallions showing the figures of Faith, Hope and Charity. On the center of the basin is represented Temperance, surrounded with allegorical figures of the four elements. On the border, a circular course of

medallions contains images personifying sciences. The work is done in repoussé and shows various reliefs.

DIAMOND CUTTING ILLUSTRATED.

The present illustration may give an idea of the diamond cutting place established by Coettermans Henrichs, from Antwerp, at the top of the grand staircase leading to the balcony of the Palais des Machines. On each side of the pavillion there is a well-fitted glass case, one of which contains rough diamonds, and large solitaires, and the other, lovely cases setting off beautiful necklaces, etc. The most conspicuous piece is a large trophy showing the arms of France. It consists of 2,000 diamonds.

I know you will not expect me to describe the splendid fête given, last Sunday, in the Palais de l'Industrie, yet, I may say that all witnesses, foreign or French, derived from the grand sight the most unalloyed pleasure. The procession, consisting of representatives of all nations of the world, was greatly applauded, and the grouping of all the flags on the elevated stage made a magnificent effect. It seemed to announce a long run of peace, with universal encouragement of art, science and industry. FRANCUS.

Paris Awards.

PRIZES AWARDED AMERICAN EXHIBITORS.

Class 10—Fairchild Co., L. W., pens, etc	Grand prize.
" 10—Waterman Pen Co.	Bronze medal.
" 11—Tiffany & Co., stationery.	Gold medal.
" 11—Baldwin & Gleason Co, stationery.	Silver medal.
" 15—Naval Observatory, standard time, Seth Thomas clocks.	Grand prize.
" 19—T. G. Hawkes, cut glass.	"
" 19—Tiffany & Co., glassware.	Silver medal.
" 19—Pacific Art Glass Co. glassware	Bronze medal.
" 20—Rookwood Pottery Co., ceramics	Gold medal.
" 24—Tiffany & Co., silverware.	Grand prize.
" 24—Gorham Mfg. Co., silverware.	Gold medal.
" 24—Meriden Britannia Co., silverware.	"
" 25—Mrs. Louise McLaughlin, bronzes.	Silver medal.
" 26—W. T. Gardner (Seth Thomas Clock Co), horology.	Silver medal.
" 26—H. H. Heinrich, chronometers.	"
" 26—C. K. Giles, anti-magnetic shield.	Bronze medal.
" 26—Tiffany & Co.	"
" 26—A. Kaheen & Co.	Hon. mention.
" 26—Trenton Watch Co., horology.	"
" 26—Waterbury Watch Co., horology.	"
" 27—Rochester Lamp Co., lamps.	Silver medal.
" 27—W. Demuth & Co., cane heads, etc	Gold medal.
" 27—Tiffany & Co., cane heads, etc.	"
" 27—Gorham Mfg. Co., cane heads, etc.	Silver medal.
" 35—Folmer, Clogg & Co., umbrellas and canes.	"
" 35—Amasa Lyon & Co., umbrellas and canes.	"
" 37—Tiffany & Co., jewelry.	Gold medal.
" 37—Fairchild Co., L. W., jewelry.	Silver medal.
" 37—J. F. Fradley & Co., jewelry.	Hon. mention.
" 37—Horton, Angell & Co., jewelry.	"
" 37—Kent & Stanley, jewelry.	"
" 37—Uibel & Barber, jewelry.	"
" 43—Tiffany & Co.	Gold medal.
" 53—Brown & Sharpe, tools, machinery, etc.	Grand Prize.

To European Competitors in the Horological Section.

THE LAST mail brought the lists of awards of prizes distributed at the Universal Exhibition; at this time the list of those who received the bronze medal is still incomplete; after this follows the "honorable mention," both of which will in time be laid before the readers of THE CIRCULAR. France and Switzerland have divided the honors pretty evenly among themselves, because the art of horology from the United States was

but poorly represented, Germany had not engaged in the strife, and the other civilized countries weigh too little to seriously enter into a conflict of rivalry with these countries, for which reason the bulk of awards went to France and Switzerland. The awarding jury consisted of: A. H. Rodanet, Paul Garnier, Chas. Sandoz, Theodore Leroy, Chas. Requier, Claudius Saunier, Ernest Antoine, Chas. Diette, for France; J. E. Dufour, Col. David Perret, Cesar Brandt, Chas. Emile Tissot, for Switzerland; and J. Triplin for Great Britain.

CLASS XXVI.—HOROLOGY.

GRAND PRIZES.

The entire Municipal School of Horology of Besançon, and the entire collection of the watch work from the Doubs, France.
The entire collection of Swiss Horology, Switzerland.
The entire collection of Swiss horological schools, Switzerland.
School of Horology of Paris, France.
Fenon, Auguste, France.
Francillon, Ernest, & Co., Switzerland.
Lepante, Henry, France.
Japy frères & Co., France.
Nardin, Paul D., Switzerland.
Patek, Philippe, & Co., Switzerland.

GOLD MEDALS.

Agassiz fils, Switzerland.
Barbezat-Baillon, Chas., Switzerland.
Bergeon frères, Switzerland.
Bergier, F. Auguste, France.
Borrel, George A., France.
Brown, Edouard, France.
Callier, Bernard A., France.
Champion, Emile, France.
Château père et fils, France.
Delepine, Emile, France.
Drocourt, Alfred, France.
Dubail, Monnin, Frossard & Co.,
Switzerland.
Fernier, Louis, & frères, France.
Girard-Pernegaux & Co., Switzerland.
Golay-Leresche, A., & fils, Switzerland.
Gras, Dufour & Neyret frères, France.
Grandjean, Henry, & Co., Switzerland.
Humbert fils, Charles, Switzerland.
Jacot, Henry, France.
Jurgensen, Jules, Switzerland.
Kulberg, Victor, Great Britain.
Lecoultré & Co., Switzerland.
Passy, Jean, France.
Planchon, Mathieu, France.
Rannaz, Alfred, France.
Reclus, Victor, France.
Rotherham & Sons, Great Britain.
Schöchlin, William, Switzerland.
General society of watch casers of
Besançon, France.
Thommon, G., Switzerland.
Zentler frères, Switzerland.

SILVER MEDALS.

Association ouvrière of Locle, Switzerland.
Baehni & Co., Switzerland.
Baschmid, F., Switzerland.
Bassely, Louis, France.
Baumann, Frederic, Austria-Hungary.
Baveaux, Alf. ed L., France.
Beillard, Alfred E., Switzerland.
Bitterlin-Schmidt, J. B., Switzerland.
Bloch, L., France.
Blum & Meyers frères, Switzerland.
Bornaud-Berthe, Eugène, Switzerland.
Bourdon, Ch. A., France.
Breting, Auguste, & Co., Switzerland.
British Horological Institute, Great
Britain.
Buhre, Paul, Switzerland.
Calame-Robert, Jules, Switzerland.
Carizet J. B., France.
Cercloux & Montandon, France.
Chamber, Syndical, of Horology, France.
Cémençe frères, Eugène & Auguste,
Switzerland.
Coudray, F., France.
Coulon, L. G., & Molitor, France.
Couvovisier frères, Switzerland.
Dessiaux, Ve. E., & fils, France.
Droz & Co., Switzerland.
Ducommun, Arthur, France.
Ducommun, Paul, & Co., Switzerland.
Eccalle, Aug., France.
Exposition collective ouvrière d'Arches,
France.
Exposition collective ouvrière de Saint
Nicolas-d'Alhermont, France.
Faure, Ed., Switzerland.
Favre-Jacot, Georges, Switzerland.
Félix, Julien, France.
Gillett & Johnston, Great Britain.
Gondy, J. Claudius, A. (Alliance d'hor
logerie), France.
Grobet, F. L., Switzerland.
Guibaudet, Gustave E., France.
Hangard, J., France.
Heuer, Edouard, Switzerland.
Huguenin, C. L., Switzerland.
Iversen & Co., Norway.
Jeanneret, A., & frère, Switzerland.
Journal Suisse d'Horlogerie, Switzer-
land.
Junod, L. E., Switzerland.
Kramer & Meser, Switzerland.
Kremer, Adam, France.
Lacroix-Favre, J., France.
Lardet, Charles E., Switzerland.
Leborgne, P., France.
Lecoultré, Marius, Switzerland.
Lefebvre Edmond, France.
L'Épée, Aug., & Co., France.
Leroy, L., & Co., France.
Margaine, Arsène, France.
Marti, S., & Co., France.
Matille frères, France.
Mathey fils, Auguste, Switzerland.
Michelet, F., Norway.
Moré & Meroz, Switzerland.
Moynet & Co., France.
Muller & Schweizer, Switzerland.
Paillard, Ch. A., France.
Paignard, Théophile, France.
Parrenin & Marguet, France.
Ratel, France.
Redard, H., & fils, Switzerland.
Réunion collective des mécaniciens,
Switzerland.
Richomme-Deparis, Louis, France.
Rozat, Louis, Switzerland.
Servet, J. Marc, Switzerland.
Société anonyme de dégrossissage à
Besançon, France.
Société suisse d'horlogerie à Montilier,
Switzerland.
Usher & Cole, Great Britain.
Usine genevoise de dégrossissage d'or,
Switzerland.
Vautier, Samuel, & fils, Switzerland.
Wandenberg, Henri C., France.
Wagon frères, Switzerland.

PARIS GOSSIP.

[FROM OUR SPECIAL CORRESPONDENT.]

TALK OF A PERMANENT EXHIBITION.—A BOOM IN EXPORT TRADE.
—REVIVAL OF ENAMEL WORK.—REMARKABLE PIECES IN THE
LOUVRE.

PARIS, October 10, 1889.

Parisian retailers and manufacturers have done a good business with some of our foreign and provincial visitors, and consequently they are anxious to find a way of bringing them to Paris every year. At a recent banquet, M. Gustave Sandoz, the Palais Royal jeweler, suggested that the main Exposition buildings should be preserved with a view of using them for an annual fair, which might rival those of Leipzig and Nijni-Novgorod. Although all listeners seemed greatly to approve of this plan, I fail to see how it could be successfully carried out over here. If Paris trade has received a great impetus from the constant influx of visitors during the last five months, I can hardly believe that our provinces have at all benefitted by it, and, therefore, we may be sure that they would strongly object to an annual repetition of this attraction. Besides, the disparaging word *fair* being applied to it, all manufacturers of good standing would refuse their support, and visitors might soon get tired of seeing an accumulation of inferior articles. Therefore I do not think that M. Sandoz' suggestion, although it was warmly received the other night, will carry off a majority of sober minds. Even if a more flattering name were given to it, the impossibility of gathering every year a large quantity of new and artistic works would soon become obvious.

A BOOM IN EXPORT TRADE.

Our business in export lines, which has been rather slack in previous years, has somewhat improved lately; yet our manufacturers are aware of serious hindrances, which it ought to be within our power to remove. French Consuls are seldom chosen from among men capable of understanding business of any kind whatever, and they rarely feel inclined to take the trouble to find out the desired information. In consequence, most of our manufacturers hesitate about extending their business beyond French frontiers; and some will never think of attempting it until they are compelled to do so by an ever-increasing competition. A book recently published by M. G. Cadoux, with the object of calling the serious attention of our government to that question of high interest, contains the most startling statements. For instance, we see in it that, in 1888, a Parisian, being on a Saturday afternoon in an important town of England, went three times to the French consulate without finding anyone who could understand him. Nobody there knew a single word of French. He was happily enabled to obtain the desired information by the help of an Austrian gentleman. What seems to me perfectly evident is that if our nation were sensible enough to send to parliament business people instead of *beaux parleurs*, matters would be entirely different.

EFFORTS TO REVIVE ENAMEL WORK.

Our high-class jewelers and goldsmiths are making serious efforts to revive the fashion for enamel work, and, among them, Froment Meurice, Poussielgue-Rusand, Bapst et Falize, Boucheron, and Vever, have obtained already some remarkable results. Enamel has never been utterly abandoned by jewelers, who have lately made some dainty pieces in that line. But goldsmiths and orfèvres-bronziers for churches had for many years somewhat neglected it. All attempts to revive it had proved very unsatisfactory. There seemed to prevail a general belief that the art of Léonard Limouzin, Pénicaud, and Raymond, must be considered extinct. A few years back, some enterprising artists endeavored to find out the old secrets,

and, little by little, they came to the conclusion that what had been done centuries ago could be done quite as well at the present day, on condition that enamelists could find patrons to encourage their efforts.

Unfortunate attempts were made some time ago by several silver-smiths to introduce enamel into articles of daily use. Goblets and breakfast cups so adorned were sold to may-be careless customers, who soon brought them back to the makers in a very bad condition, and could not be made to understand that such repairs must be very expensive. I have seen some of these pieces; most of them consisted of Renaissance ornaments, finished off in oxidized silver, whose background and intervals, previously hollowed by the aquafortis process, had been filled up with enamel of well opposed colors. The work was so obtained at a rather reasonable price; but I must say that it would not bear a very close inspection. No doubt our old artists were right in removing the metal (which had to make room for enamel) by the help of several gravers, variously edged for the purpose. By so doing they managed with their skilful hands to finish their pieces to a nicety. Until we find another process, allowing us to do the same work quite as well but much quicker, we had better follow their example.

A VISIT TO THE LOUVRE.

The Galerie d'Apollon, at the Louvre, contains some beautiful specimens of enamel work. In the glass case where are exhibited

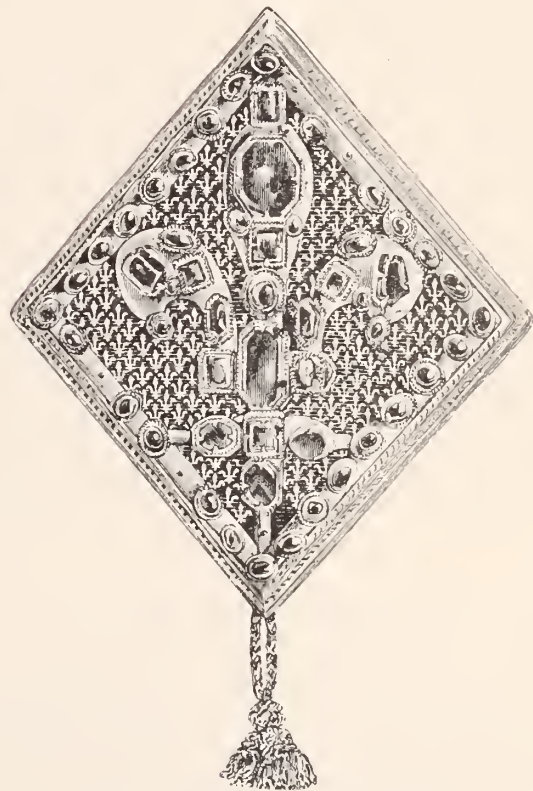

AGRAFE (CLASP) OF SAINT LOUIS.

the crown jewels, there is one belonging to that class, but perhaps more interesting from other points of view. I only regret that, through being placed at the top of the raised display, somewhat far from the glass, and at some distance from the nearest window (the case being in the center of the room), a great deal of its effect should be lost on the visitors. This remarkable piece (reproduced here) is generally called the *Agrafe de St. Louis*, and is supposed to have served as a clasp for the royal mantle of the Godly King of France—yet no document has ever confirmed this statement. Before being brought to the Louvre it belonged to the treasure of St. Denis Abbey, whose records of 1534 and 1634 mention it. According to all experts, it shows the exact characters of the works made in the second half of the thirteenth century. This, added to the fact that the emblem of French royalty is conspicuously on it, is well calculated to encourage the general belief. In the shape of a lozenge, it is 187

millimeters high and 165 mm. wide. On a deep blue enamel background we see what resembles a field of tiny fleur-de-lys, close together, on which stands out a large one adorned with amethysts, emeralds and garnets, some of which are cabochons and some table-cut. On the inner borders of the frame, whose outer rim is covered with mouldings, is a run of garnets and sapphires (cabochons). The Louvre catalogue of jewels mentions it as "a gilt silver clasp adorned with precious stones."

If you look at the glass case, as illustrated in my letter of last June, you will see this beautiful piece placed between two crowns. The one on the right-hand side is supposed to be, as to the framework, the real crown worn by Louis XV. on the day of his coronation. The stones are all fac-similes, and I must confess that they give a very poor effect. Here is a description of the true dazzling head-piece as made by Rondé, royal jeweler, who, previous to the great event, published it in the *Mercur*, and which I thought you might read with pleasure. It runs as follows:

"The band or diadem of this superb crown is bordered with two rows of pearls and adorned with eight stones of different colors, very large and perfect. Between them are three diamonds held together by some very light ornaments. A large diamond fleur-de-lys rises above each one of the colored stones on the diadem, and a fleuron consisting of three diamonds and three colored stones is placed between the fleur-de-lys. [Here is a mistake, since we see the fleur-de-lys above the groups of three diamonds, and not above the large single stones.] The top part of each one of the royal emblems consists of a table diamond, called Mazarin; the sides and the body are represented by three other diamonds, and at the base there is another one, elongated. The largest diamond is very perfect and weighs 547 grains. It is called the Regent, and was bought for the King by the Duke d'Orléans. It forms at once the body and the base of the front fleur-de-lys. A row of pearls, running between two rows of small brilliants, gathers at the top the eight branches, and the base of the capital ornament. Underneath, between each two branches, comes out a large diamond, which is like the budding of a new branch. The head of the top fleur-de-lys is formed by the pear-shaped diamond, Le Sancy. The sides, the center parts and the lower ones consist of sixteen diamonds arranged so as to correspond to the thickness and importance of the predominant stone. The cap of the crown is of violet satin, adorned with twenty-five diamonds held together by a very light embroidery, etc."

JASEUR.

MYSTIC JEWELS.—In 1400, an Italian writer set forth the virtues of the various gems, indicating the month in which it was proper to wear particular stones. The idea took, and for some time it was the fashion in several Italian cities to have the precious stone of the ring determined by the month in which the bride was born. If in January, the stone was a garnet, believed to have the power of winning the wearer friends. If in February, her ring was an amethyst, which protected her from poison and from slanderous tongues. The bloodstone was for March, making her wise, and enabling her with patience to bear domestic cares. The diamond for April, keeping her heart innocent and pure, so long as she wore the gem. An emerald for May made her a happy wife, while an agate for June gave her health and protection from fairies and ghosts. If born in July, the stone was a ruby, which tended to keep her free from jealousy of her husband, while in August the sardonyx made her happy in the maternal relation. In September, a sapphire was the proper stone, it preventing quarrels between the wedded pair; in October, a carbuncle was chosen to promote her love of home. The November-born bride wore a topaz, it having the gift of making her truthful and obedient to her husband, while in December the turquoise insured her faithfulness. Among the German country folk, the last-named stone is to the present day used as a setting for the betrothal ring, and, so long as it retains its color, is believed to indicate the constancy of the wearer.

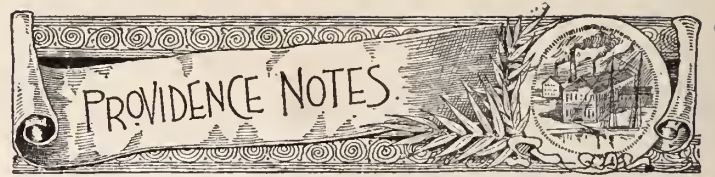

[FROM OUR SPECIAL CORRESPONDENT.]

PROVIDENCE, R. I., Oct. 15, 1889.

Since my last letter to you, I am glad to note that the business generally with the manufacturers has greatly improved, I might say boomed, in certain lines, and live houses have had all that they could possibly attend to. Some firms have really been forced to ask their employees to spend their evenings at the bench, in order to be able to fill their orders and satisfy their customers in anything like reasonable time, and some have countermanded their orders from the fact that they could not wait longer for the goods to be manufactured. Duplicate orders have been received for the past two or three weeks in very satisfactory amounts, showing conclusively that the jobbers are moving the goods. The money market during the past month has been very close, so that collections have been harder to make than though it had been easier, but still there has been no scarcity to speak of. Failures too have not been heard of worth mentioning during the past four weeks.

The Gorham Manufacturing Co.'s works was the scene of a small fire on Thursday last, which was extinguished by the prompt aid of the city fire department, the loss being merely nominal.

The executor of the estate of the late Thomas H. Lowe, on Tuesday the 24th ult., presented in the Municipal Court his account of the estate showing a balance of \$41,139.23.

Col. Theodore A. Barton, of the Gorham Manufacturing Co., was the happy recipient of a reception tendered to him by the Gen. A. E. Burnside Camp, in honor of his re-election as Col. of the Rhode Island Division of the G. A. R.

Messrs. J. Briggs & Son, report business better with them than at any time since the phenomenal year of 1883, their motto is "upward and onward," which accounts for the increase in their heavy orders received of late.

Mr. W. R. Dutemple has arrived home from Columbus, Ohio, where he went to attend the meeting of Sovereign Grand Lodge of Odd Fellows.

Mr. R. G. Schutz has paid a mortgage recorded against him for \$150.00.

Mr. Charles Alpin, an old manufacturer of jewelry, has had a stroke of paralysis resulting from his attempt to board a horse-car and falling off and injuring his spine.

Mr. Benjamin Allen, of the extensive firm of Benj. Allen & Co., of Chicago, was in the city the past week on business, and placed some very flattering orders with our large manufacturers for the holiday trade, which will soon be upon us.

H. F. Salisbury has given a chattel mortgage on his business and fixtures for \$200.00.

J. R. McAdams & Co. have dissolved partnership, and the business has gone into liquidation.

B. Smith & Co., have removed to No. 52 Aborn St.

W. A. Griffith, of R. L. Griffith & Son, is to be seen again on the street, after an illness of some seven weeks.

James G. & G. F. Whitehouse, have removed to No. 77 Dorrance st. from No. 116 Pine st.

Henry Blundell & Sons had an exhibition at the state fair at Cranston, several jewelry presses and drops, which proved quite interesting to the public.

W. T. Lewis has admitted as partner, his son, Wm. T. Lewis, Jr.,

and the firm name now is Wm. T. Lewis & Son, and will continue business at the old stand.

Fessenden & Co. have discharged a mortgage recorded against them, for the sum of \$5,000.

Thomas F. Kiley & Co. have closed up and gone out of business. Alfred Barton, Ostby & Barton's New York representative, joined the Benedicts on the 13th ultimo.

W. J. Feeley has returned home from his trip aboard, where he had an extremely pleasant time during the three months past.

Waite, Thresher & Co., are manufacturing one of the finest and most attractive lines of gold bar pins, mounted in white stone, Moonstone, and Pearls, to be found in the market this fall, the result of which is that they are receiving duplicate orders on the same.

The "Perfection" cuff holder manufactured by Barstow & Williams is meeting with great success. It is made of Roman and bright rolled gold plate and in both plain and oxidized silver.

D. R. Child & Co. make one of the best sleeve-buttons to be found in the market.

Mr. Braitsch, of Messrs. Hearn & Braitsch is confined to his home by a very severe attack of sickness, and it will be some days before he will be able again to resume business. A heavy cold was the primary cause.

Charles F. Irons is now making ten jewels for the Grand Encampment of the I. O. O. F. of the state of Kansas.

W. A. Beatty & Co. still remain head-quarters for hoop earrings, the firm manufacturing more of this style than any other house in the market.

William M. Fisher & Co. make a specialty of 14kt. gold bead necklaces, also gold and silver chain, and chain trimming. They report business quite lively this fall.

Hiram Howard, W. R. Dutemple, and B. A. Ballou attended the meeting of business men at the Board of Trade Building on Tuesday last, at the request of Gov. Ladd as representative of the Jewelers' Board of Trade.

C. Sydney Smith, manufacturer of solid gold goods, says that he is driven with orders to such an extent that he finds ten hours per day entirely too short to fill his orders on time. Consequently one can see his extensive works brilliantly lighted until about 11 P. M. every night excepting Sundays. Comment is unnecessary.

B. E. Daggett has no complaints to make in regard to the reception he received while on his recent western trip; the number of orders he received justifies him in believing that his line of plated rings are more popular, if possible, than ever before.

O. C. Devereux & Co. are rushing on their popular line of "Stonine" goods which seem to have found place with the jobber and are likely to stay for some time to come.

Chas. A. Russell & Co. have one of the most extensive lines of gold and plated emblems in both pins and charms that has been seen this season; their goods are A1 in style and finish and will always be found to be as represented.

Fred. I. Marcy & Co. are doing a good business with their new "Eiffel" collar button, which is extremely unique in its construction, having a white enamel back which comes in contact with the person instead of the old fashioned metal back, that in warm weather corrodes and discolors.

M. Fitzgerald & Co. vs Z. Auerbach, of Montreal, is on the docket of the Justice Court for Thursday Oct. 17th; this case was postponed from one week ago. Mr. Auerbach gave Mr. Fitzgerald a note in settlement of his account, which was never paid, hence the suit.

John L. Fowler has returned from a week's sojourn at home in New York, where he went to celebrate his birthday, and where he gained five pounds avoirdupois.

Stephen Howard, of Howard & Son, derived so much benefit to his health from the trip he made to the Pacific coast last spring, that he concluded to make another journey this autumn to the same point, and he is now in San Francisco. Last spring he went there mainly on account of his health, but this fall he goes in the interest of their business chiefly, and has taken with him a full line of samples of buttons as well as of the articles made by the Sterling Co.

Geo. L. Vose & Co. are busily engaged on something brand new for the coming season of 1889.

So extensive has the demand become for their celebrated seamless filled chains that Kent & Stanley, 7 Eddy st., have found it advisable to establish agencies or offices in different parts of the world. As a result of their creditable display at the Paris Exposition, a demand for these goods has sprung up abroad and M. Leon Lams, who has an office at 6 Rue d'Angouleme, has been appointed their foreign agent. An agency has also been opened in San Francisco in the Phelan building, and W. E. Pettes & Co. will have charge of it. The new office at No. 17 Maiden Lane, distinguished by a conspicuous sign announcing the specialty of the house, must not be overlooked. Altogether Kent & Stanley are now in splendid shape to cope with the rapidly increasing business that is rewarding their enterprise and liberal policy.

Of the large variety of rings manufactured by Ostby & Barton, their "Triple Crown" filled ring not only holds its own but every year the demand is increasing. This is sufficient evidence to show that the trade know when they get a good article.

Charles F. Irons and Charles A. Russell have both been attending the triennial conclave of the Knights Templar at Washington. Mr. Irons' design was adopted as the official badge at the ceremonies. Both gentlemen were delighted with the magnificence of the demonstration and the royal entertainment accorded them by the Templars.

Foster & Bailey have "a full hand in glove buttoners," and it may also be said that they have their hands so full in trying to supply the demand for them that their sample drawers are in a chronic state of emptiness so far as glove buttoners are concerned. But Foster & Bailey have a big shop, and when they drive it to its full capacity there is no danger of a famine in glove buttoners. And, what is more, the buyer of goods manufactured by this house can be dead sure that he is getting a reliable article. No tin plate gold film emanates from here. Everything is of the quality represented and will stand the test of wear.

FAIRFAX.



[FROM OUR SPECIAL CORRESPONDENT.]

TRADE REPORTS FROM NEW ENGLAND'S METROPOLIS.

BOSTON, October 17, 1889.

All the industries of New England have begun to feel the stimulation which cooler weather always produces. The general market continues firm in nearly all departments, with a fair amount of business doing. The market continues quiet in manufacturing circles but values are holding encouragingly steady. The iron trade shows promising strength, and local merchants rely hopefully upon the advances being made in outside markets.

The Boston money market is working along with a good degree of steadiness. There is a sufficient degree of uncertainty in regard to

the monetary requirements of the future to give a firm backing to rates, and there is sufficient money-seeking employment to supply the current demand. There is some little excitement in speculative circles over the recent Atchison deal, but this is not of a permanent character. General trade reports from nearly all the interior distributing centers show that the volume of trade is being well maintained, with an active movement in all directions. This is toning up the Boston market, which has already quite recovered from the slight depression caused by unfavorable weather in the latter part of September.

So much for the situation at large, all the favorable features of which are noticeable in the timeliness with which our jewelers are getting ready for the holiday boom. Whatever disappointment may have been felt, here and there, because of the lowering skies of merchant's week, has given place to a hopeful anticipation of the immediate future.

"October is always a busy month with us," said an officer of the Acme Silver Plating Company. "The stock for the October trade was shipped long ago, but the dealers are always running out of some one line of goods or other. Trade was never so good as now, or rather as it has been this season. There are no special novelties for the holiday trade. Of course, there are new designs in silver plated goods, lots of them, and some of them are very pretty and odd. People seem to call for a more substantial class of goods now than in former seasons. I do not mean that there is less demand for silver plated goods, but the designs now must look solid to catch the eye. Yes, business is good, and the retailers in the country are making money."

Mr. Ripley, too, of Ripley, Howland & Co., says their house and the line of goods they carry are booming. "Trade was never so good," he declared yesterday. "It may be because we handle a pretty good class of goods and it may not. Any way we are doing well, and think the trade out in the country must be very large. The diamond trade in particular is better, I judge. Many purchasers were waiting for a drop in prices, but the drop hasn't come, and now they must go into the market and buy any way."

A high-up official in the Howard Watch and Clock Company says the trade in tower clocks is booming. Many small town and city corporations in all parts of the East are putting clocks into their mill and factory towers, into their churches and town halls, and into their streets. Of watches, fine timekeepers, the local watch dealers are selling many that are purchased and used as gifts. The Howard Company received the order for the watch which was last week presented to that popular Boston journalist, John N. Taylor, of the *Globe*.

A. D. Cairns, of the A. D. Cairns & Co. manufacturing concern, says that the October trade for the wholesalers has not been quite what was expected. "If," said he, "we had done all we thought we should, we would have had our hands full. Of course, trade is better than it was some time ago, but not up to the average, taken all in all. In a week or two we will have all we want. Yes, I suppose that means trade is backward. The holiday goods? Well, it is a little early for those. I have not yet been over to New York, and have not seen much of the holiday goods yet. There are certainly more new designs in jewelry, both cheap and high priced, than ever before. The Paris Exposition may have caused that. The designs are better, too, more substantial and less given to extreme fragility."

Mr. Cairns is the President of the Boston Jewelers' Credit Association. This was founded in June last and now includes these firms: W. S. Crown & Co., Foster & Emerson, W. N. Thompson & Co., H. M. Holbrook, the Kinsfurts, the Metropolitan Manufacturing Co., Gordon & Burgen and A. D. Cairns & Co. Its object is to protect its members against loss from the credit system, so generally followed by a certain class of jewelers. "You understand," said

Mr. Cairns, "that we could not do business if we did not permit our customers to deal with us on credit. But the system subjects us to so many losses through the wilful dishonesty of the smaller trade that we formed our association to meet their designs. As often as one member of the association discovers an attempt at unfair dealing on the outside, the other members of the association are notified, and the spread of the loss is prevented. So far the system has met with considerable success, and we think that we have derived much benefit. The association includes all the dealers of our class in the city." A singular feature of the association is that outside the offices of the members of the association it is unknown in the trade in this city, and what is yet more singular in view of this fact, is that its members and officers do not show the slightest hesitancy to tell all about it.

Manager Stone, of J. W. Tufts & Co., says that the trade is excellent; better than ever before, and increasing all the time. The orders far exceed those of the same time last year. The factory is running every night till 9 o'clock, and has been for three weeks. Never before have they begun to run late hours until Nov 1. There are no decided novelties, although bon-bon boxes are made low, in square and round moulds. There are some new designs in sardine boxes and biscuit jars. A new process invented by Mr. Tufts himself is being used with not a little success. It consists in a species of decoration that cannot be called *repoussé* or raised work as there is no indentation on the inside. It is chasing that is not produced by a steel die, but by a press capable of exerting a force of one hundred tons to the square inch directly on the ware itself and making a beautiful clear impression.

Mr. Pratt, of Floyd, Pratt & Rounds, said yesterday there was no special increase of trade this month over last, and there were no particular novelties.

Mr. Cummings, of Josiah Cummings & Son, trunk makers, reports that his business is steadily on the increase. This is due in part to the growing demand for his celebrated steel bound sample trunk, which weighs less than a wooden trunk of larger size and will stand all attacks of the baggage smasher.

D. C. Percival said that trade was better this year than it was the same time last year. Mr. Percival is selling nothing but novelties, and he thinks that the Paris Exposition does not influence the American trade much as there are only four American jewelers exhibiting there.

Joseph B. Thaxter, of the firm of Thaxter & Bros., opticians, was married early this month to Miss Edith M. Corbett, of Malden. The couple will reside in Boston, after an extended wedding tour.

A report has it that the estate at present occupied by Shreve, Crump & Low will next year be used by A. Shuman & Co., the clothiers.

Daniel F. Pratt, of Daniel Pratt's Sons, is home from Europe.

So is Irving Smith, of Morrill Bros. & Co.

Horace Partridge & Co. received last month the largest consignment of jewelry and fancy goods ever received at the Boston port from abroad. There were a total of over 3,000 packages and the duties footed up \$45,000.

Jacob P. Palmer, now with Tiffany & Co., New York, was formerly associated with Palmer, Batchelder & Co., of this city.

George E. Lyford & Brother, have retired from the trade. They did business in the same spot, at 207 Washington st., for over half a century. Josiah Gooding founded the business in 1836. The firm's stock was placed in the hands of Lewis I. Bird & Co. for disposal at auction.

The newly organized Alexander Company, whose start-off I noted about a month ago, report good progress. Their establishment is lighted with the Edison system.

LEON.

Fashions in Jewelry

A Lady's Rambles Among the Jewelers and Dealers in Art Glass, Keramics and Bric-à-Brac.

THE fashionable weddings of the past month have developed styles in jewelry as well as in bonnets and gowns.

* * * * *

PEARL brooches and pearl necklaces are leading features in the accessions of a bride's toilette, although pearls are not worn to the exclusion of diamonds.

* * * * *

AT several of the swell New York weddings, the bride wore a pearl necklace while her veil and the lace draperies of her bodice were held in place with diamond stars, that glistened here and there among the orange sprays and wreaths.

* * * * *

A FASHION set by Queen Margheurita, of Italy, is gaining power here. This consists in adding a new string of pearls to the bridal necklace, on the anniversary of each wedding day; the pearls being, of course, a gift from the husband.

* * * * *

ANOTHER practice, and one more universally observed, is a souvenir to the wife, on the occasion of the birth of each child. Sometimes these gifts are rings set with rare gems; again they are unique brooches, or it may be an additional strand of pearls or diamonds, a necklace or bracelet. It frequently happens that it is only an artistic trinket to attach to the engagement bangle.

* * * * *

MRS. KENDAL, the English actress who is now delighting American audiences, wears on her chatelaine five little bells, one to represent each of her children. These bells are curiously wrought and inlaid with tiny gems, and bear on their margin the monogram and date of birth of the child thus kept in memory.

* * * * *

BRIDESMAIDS' presents have come to be important features, not only at English weddings, but in our own country. These are the gift of the bridegroom and are frequently as unique as they are costly.

* * * * *

CHATELAINE watches have already made their mark at fashionable weddings, as bridesmaids' presents. These have been greatly improved upon of late, so they can be adopted to form the chatelaine, a brooch (with the recipient's initial letter set in diamonds on an enameled ground) and also a bracelet.

* * * * *

BRACELET watches are popular bridesmaids' presents. At a fashionable wedding early last month, the bridesmaids were supplied with bracelet watches set around with rubies and sapphires.

* * * * *

DOUBLE heart moonstone bracelets, heart-shape moonstone

brooches, outlined with brilliants, and crescent and horseshoe pins, are other popular gifts for bridesmaids.

* * * * *

WATCHES, as made now-a-days, are many of them charming objects to look upon, their cases and open faces being elaborately decorated.

* * * * *

AMONG the new-comers in watches, are the open faced ones set in rough gold, in which gems are imbedded.

* * * * *

WATCH dials continue to appear in unexpected places. Card cases with a tiny watch set in one corner bid fair to have somewhat of a run, as these are very useful.

* * * * *

AMONG the new watch bracelets are those set in curb chain style in hammered gold. This has a peculiar effect, the whole surface being indented.

* * * * *

AN IMPORTED bangle affording a novelty, is of gold wire, with a bar of alternate turquoise and diamonds, set in little claws, close together; the specialty consists of this bar expanding, and going back to its place with a peculiar spring as the bangle passes over the hand and contracts to fit the wrist.

* * * * *

MANY novelties are this season introduced in both pocketbooks and purses. The former are gold or silver mounted, while the purses are of woven gold, silver or silk thread.

* * * * *

DECIDEDLY unique are silk purses into which are woven seed pearls. These purses have gold mounts.

* * * * *

GOLD and silver trimmed leather goods are as fashionable as ever. All sorts of hides and skins are employed including the lizard skin.

* * * * *

A NOVELTY in way of a lace brooch comes in three sizes. It simulates a pansy with the upper and larger petal of carbuncles, the lower ones of moonstones, with a small diamond in the center and the stalk gold.

* * * * *

VERY dainty are the brooches that come in the form of a gold but-tercups with diamond sparks tipping the stamens and a pearl in the center.

* * * * *

STERLING silver chatelaines, copied from antique designs, delight the feminine heart. Though these are frequently a heavy burden to wear with their silver mounted adjuncts of tablets, pencil, scissors, pin-cushion, vinaigrette, watch, etc, etc.

* * * * *

STERLING silver waist buckles are out in new and pleasing designs to meet a popular demand. The buckles, in the center of which

appears a French miniature painting, have already found many admirers.

* * * * * *

THESE French miniatures appear in brooches, bracelets, pendants and occasionally on watch cases.

* * * * * *

ONE of the prettiest bonbonnières seen, had set in its cover the miniature copy of a Gainsborough beauty in picturesque costume.

* * * * * *

THERE are also bonbonnières that do not exhibit the pictures of court beauties on the outside of their covers, but do conceal a portrait of a modern young man inside an extra lid in the cover.

* * * * * *

THIS style of bonbonnière recalls the engagement locket, about which our readers have heard before. These flat, oblong and heart-shaped affairs, which are worn out of sight inside the corsage, are very popular. Sometimes they conceal from the vulgar gaze a portrait, sometimes a lock of hair, and sometimes only a "little faded flower."

* * * * * *

FOR the patrons of sleeve links a new pattern has been provided: little padlocks and keys connected by small chains.

* * * * * *

QUITE new bonnet pins are in circular and pear shapes and of deep gold, in close set sections, with crinkled edges.

* * * * * *

BRACELETS with flexible links afford pleasing effects by the employment of different colored golds and enamels.

* * * * * *

FLEXIBLE necklaces are fashionable, especially those that simulate a chain of field flowers.

* * * * * *

AN EFFECTIVE necklace is composed of fine garnet hearts outlined with brilliants, and linked together.

* * * * * *

AMERICAN precious stones, especially those of fine color, are being more and more patronized. One sees them in queer shaped silver and in gold nugget rings for gentlemen, also in brooches and bracelets for ladies.

* * * * * *

FINGER rings are worn by everybody and the assortment is sufficiently diversified and extended to accommodate all tastes.

* * * * * *

GEMS are set high or imbedded, as best accords with the fashioning of the ring, and the value of the stone.

* * * * * *

HALF hoops of diamonds find admirers, and the same may be said of the Marquise settings.

* * * * * *

THE pea-pod ring, as the name suggests, shows an opening on top,

through which protrudes a line of granulated pea-shaped stones.

* * * * * *

ALL gold and sterling silver jewelry presents many and pleasing variations of twisted rope coils and knots, in instance of which may be cited the well-known "razzle dazzle," the "union knot," the "true lover's knot," "sailor knot," "curb chain knot" and the serpent contortions.

* * * * * *

THESE twisted ropes, coils and knots figure most conspicuously in finger rings and brooches—not infrequently enamel and small stones enhance the value of this class of jewelry.

* * * * * *

PLEASING designs have appeared in the new silver scent bottles and vinaigrettes. Some are richly chased, others are enameled in floral designs while etching is to be seen on others.

* * * * * *

OBLONG shapes, square and flat round shapes are included in the vinaigrettes; there are also many fancy designs, as an Eiffel tower, a flower, a powder horn and a tiny whisky flask.

* * * * * *

SILVER mounted articles for the toilet are, as a rule, richly chased. Many have a bright finished center in diamond, circular or shield shape, on which a monogram or date may be engraved.

* * * * * *

WHILE chasing is a very popular form of decoration for table ware, other styles are fashionable.

* * * * * *

LADIES who sigh for the fashions of "ye olden time" may be in fashion and yet have on their tables full tea or coffee sets with bodies in antique fluted style, bright finished spouts and ebony handles and knobs.

* * * * * *

WATCH chains have appeared from which dangle Eiffel tower seals.

* * * * * *

THOSE who admire celebrities can have them always with them now in the shape of a paper knife. Gladstone and Irving were the first victims to this fad, being made in silver. Their admirers who perpetuate them in this convenient article, seize their favorite by the legs, stick his head between the lines and cut the paper with his spinal column.

* * * * * *

PIERCED work is more or less popular both in silver and gold. One sees pierced borders in table ware, in trays and dishes for the toilette, on brooches, and settings for finger rings.

* * * * * *

SAPPHIRES and opals are both fashionable. Hungarian opals are especially desirable.

* * * * * *

THE story of Mrs. Mackay's sapphires, which is periodically told, always inspires an ambition among American women for a fine specimen or two. The last time that one "absolutely flawless"

Mackay sapphire was reported upon, it measured "all of four-tenths of an inch in diameter and surpassed in beauty any other in the world."

* * * * *

A HANDSOME bracelet is made of flexible square links, in which are imbedded small stones of differing hues, a diamond in one link, an amethyst in another, a beryl in another, and so on throughout the list.

* * * * *

PENDANTS are much worn. Double stars of diamonds and clusters of opals or other gems, are favorites.

* * * * *

SCARF pins are worn quite large. A fine pearl represents a very desirable scarf pin.

* * * * *

A DIAMOND set in gold, without backing, affords a fashionable scarf pin for day weddings and other occasions. A thin diamond set *glacé*, as described, shows to advantage.

* * * * *

FANCIFUL designs in scarf pins are rendered effective by the employment of fresh water pearls.

* * * * *

WHEN a single pearl is mounted for a scarf pin it ought to be of good color and luster; pear shape is the form preferred.

* * * * *

SCARF rings are out in a variety of patterns to meet a moderate but growing demand.

* * * * *

STUDS are worn with full dress suits; three small studs represent the correct style.

* * * * *

A MAN may gratify his taste to the extent of wearing small diamond studs, small pearl studs or gold or white enamel studs, and yet be in the fashion.

* * * * *

WHILE the umbrella is a strictly useful article, a certain element of quaintness must appear in the handle to be *à la mode*.

* * * * *

THE newest among the new umbrellas are those supplied with malacca canes and gold or silver tops. Japanese handles in many shapes are imported and adopted.

* * * * *

SILK watch chains are much worn.

* * * * *

GOLD watch chains for men are more massive than formerly, and appear outside the waistcoat from the button hole where the swivel is attached, to the left pocket.

* * * * *

IT is no longer a crime, even among the four hundred, to wear a watch chain with evening dress.

THE envy of many women, but beyond the reach of all save a favored few, are the gem-set laces designed as decorations for the corsage.

* * * * *

A BRACELET worthy of mention is a gold hoop wound around in spirals with gold ribbon. Between each spiral is a diamond.

* * * * *

One of the most interesting cases in a leading New York jeweler's store is the one devoted to fans. The collection includes feather fans and hand-painted fans, and fans with gold and silver mounts.

* * * * *

DESIRABLE fans are those that copy historical ones. Many ladies will pay a price far in excess of actual value for the fac-simile, for instance, of one of Mme. de Pompadour's or the Duchess of Devonshire's fans.

* * * * *

FOR deep mourning wear Fowler's English Crape Stone jewelry still maintains its popularity. The finish of these goods is exactly like that of the finest English crape, hence it is in perfect harmony with all the fashionable mourning costumes, and from its simplicity, is adapted to the tastes and feeling of those who have suffered bereavement.

Art Glass, Ceramics and Bric-à-Brac.

FLOWER receptacles—their name is legion, and the newer kinds are worthy of consideration.

* * * * *

THERE is a long range of inexpensive but attractive articles in bamboo, such as the bamboo easels for fireplaces, and the tubes for the corners of rooms and for laying on dinner tables.

* * * * *

THERE are flower stands in basket work, made on the same plan as the palm leaf table, in three tiers, the basket large enough to hold a growing flower.

* * * * *

THE CHINA cactus and tulips for laying on the table cloth find purchasers.

* * * * *

COALPORT china receptacles are attractive from their pure whiteness and original forms.

* * * * *

VASES of Bonn ware, in tapestry ornamentation, afford pleasing flower receptacles. The same may be said for the jardinières of Bonn faience with gilt decorations.

* * * * *

ATTENTION is again called to the decorative pots in Leeds ware for palms and other foliage plants. Some of these are very effective, and are finding a ready sale.

* * * * *

CUT glass ware affords numberless articles suited to the popular trade, such as rose bowls and jars in Florentine patterns, flat celery

dishes, bouquet holders and unique vases for long-stemmed flowers.

* * * * *

TERRA COTTA statuettes are out in new designs that will be sure to please.

* * * * *

REAL Berlin bronzes are imported in large numbers to supply the increased demand for this class of ornaments.

* * * * *

HIGH standing lamps, are, if possible, more fashionable than ever.

* * * * *

QUITE new are the high lamps on artistically wrought iron pedestals.

* * * * *

A NOVELTY in standing lamps is one having a telescopic standard, by which the light may be raised or lowered at pleasure. One seen had a stuffed bird perched on the standard. This bird apparently supported the lamp with its decorative shade of silk and lace.

* * * * *

ONE OF the handsomest piano lamps seen this month rested on a Mexican onyx column. Others were mounted on Mexican onyx pedestals elaborately carved and furthermore decorated with gilt trimmings.

* * * * *

BRONZES, both French and real, find ready customers.

* * * * *

SWING kettles for "five o'clock tea" are again in request. These are made in a great diversity of patterns. Copper is this season a favorite metal, but not to the exclusion of decorative brass and the artistically wrought iron kettles.

* * * * *

SOME of the five o'clock tea kettles are swung from high standards that rest on the floor; others swing over a spirit lamp, and rest on the table.

* * * * *

WEDDING gifts of choice china and glass are now in order; those in satin-lined plush and velvet cases find ready sale.

* * * * *

TETE-A-TETE sets in handsome cases are decidedly seasonable at the present time.

* * * * *

THE French porcelain plates decorated with hand-painted portraits of celebrated French beauties are almost as popular in their way as are the French miniatures of court beauties that are mounted on brooches and bracelets.

* * * * *

MARBLE figures and busts are favorites in house decoration, notably the exquisite Carrara marbles.

ESPECIALLY desirable for wedding and holiday gifts are decorative pieces in Royal Worcester, Crown Derby, Sevres, Hungarian and other choice wares.

* * * * *

APPROXIMATE wedding presents are toilet articles in Royal Worcester which show perforated borders.

* * * * *

THE Carlsbad ivory ware affords many pleasing designs in vases, urns and mantel pieces, with pierced handles, and designs wrought in raised gold.

* * * * *

CUT GLASS table ware now comes in such unique shapes and designs, that in many dining rooms it has become a powerful rival to silverware.

ELSIE BEE.

The Jewelers' Security Alliance

President, DAVID C. DODD, JR.

First Vice-President, AUGUSTUS K. SLOAN.....Of Carter, Sloan & Co.
Second Vice-President, HENRY HAYES.....Of Brooklyn Watch Case Co.
Third Vice-President, DAVID UNTERMAYER.....Of Keller & Untermeyer.
Treasurer, CHAS. G. LEWIS.....Of Randel, Baremore & Billings.
Secretary, GEO. H. HODENPYL.....Of Hodenpyl & Sons.

EXECUTIVE COMMITTEE.

J. B. BOWDEN, *Chairman*.....Of J. B. Bowden & Co.
C. G. ALFORD.....Of C. G. Alford & Co.
N. H. WHITE.....Of N. H. White.
F. KROEBER.....Of F. Kroeber Clock Co.
SILAS STUART.....Of Silas Stuart.
H. H. BUTTS.....Of H. W. Wheeler & Co.

EXAMINING FINANCE COMMITTEE.

J. P. SNOW.....Of G. & S. Owen & Co.
HENRY ABBOTT.....Of Henry Abbott.

For further information, Application Blanks for Membership, By-Laws, etc., Address P. O. Box 3277. 170 Broadway, New York.

The regular monthly meeting of the Executive Committee was held at the Alliance Office, on Oct. 11th. There were present A. K. Sloan, President, and David Untermeyer, Vice-President; J. B. Bowden, Chairman, and Messrs. Alford, Butts, Stuart and George H. Hodenpyl, Secretary.

The following were admitted to membership Sept. 13: Thos. H. Seaman, 679 Myrtle Ave., Brooklyn, N. Y.; H. S. Dusenbury & Son, 4 North street, Middletown, N. Y.; Otto G. Berners, Le Mars, Iowa; Frank Towle, 1045 Washington street, Boston, Mass.; R. C. Richmond, Miles City, Montana.

THE Chinese Minister has presented to the Smithsonian Institute at Washington, a "jade" ring, about ten inches in diameter and one-eighth of an inch in thickness, with a hollow center about four inches in diameter. It is of a pale hue. The ring is known as the "Han Pek" jewel of the dynasty of Han, an old-time monarch of 3,500 years ago. Court officials of that day, when an audience was accorded them by the emperor, held the ring in both hands and thrust their fingers into the opening to guard against moving their hands while addressing the throne, the emphasizing of their remarks by flourishes of the hands presumably being contrary to official etiquette. The ring was used as an emblem of submission or respect for the sovereign. It was recently unearthed from a sepulchre, having been buried with the owner.



[FROM OUR SPECIAL CORRESPONDENT.]

TRADE REVIVAL IN ENGLAND—MEMORANDUM AND CREDIT ABUSES—FASHION'S LATEST WHIMS—THE "ALPINE" BANGLE—CRAZE FOR THE ANTIQUE—FRAUDS IN OLD SILVER—CLERKENWELL'S NEW INDUSTRY.

LONDON, October 10, 1889.

A tour around our manufacturing quarters made expressly to get the closest information for this letter, has more than confirmed the favorable expectations I have for some time had as to the improving condition of our trade. Speaking generally, I do not think there have been brighter prospects at this season, for many years past. Manufacturers in nearly every department are full of activity and are very sanguine that the improvement experienced during the past few months will not only be continued, but will be more pronounced as the year advances. All are looking forward to a good Christmas trade. The best feature about the present manufacturing activity is that it is occasioned by the execution of orders actually on the books and is not merely a sort of a wise provision for an expected demand.

The fact that the bulk of the goods now being turned out are to be sent away as soon as completed, precludes the fear of heavy accumulations of stock at the year's end. The export orders received are good, and those exported from the Australian colonies, and the Cape are said to be better.

MEMORANDUM AND CREDIT ABUSES.

Notwithstanding the increased attention to their workshops and warehouses necessitated by this improved and improving trade, our manufacturers are giving some attention to certain phases of their system of trading which other persons, not in the trade have long regarded with disapproval. The unreasonably long credit given in the jewelry and horological trade, and the injudicious extent to which the "approbation" system is made use of are not met with in any of our other trades. The supply of goods on approbation for long periods is very unfair and very prejudicial to the manufacturer and in my opinion in most cases does the trade very little good, and the system of almost unlimited credit is alike injurious to both. Traders would not get into debt so deeply, or so frequently, if the facilities were not so great for doing so.

A man honestly meaning to do right commences business as a retailer with a moderate capital, but he soon finds that he can get credit to ten times the amount of his capital. Unless he has a strong mind of his own he accepts the opportunities that are presented to him and is thus able to have in his charge a stock five times at least larger than he ever intended to have and in too many instances larger than he ever ought to have had.

Whether the terms of credit in our trade will ever assimilate more nearly to those prevailing in other trades I cannot say, but I do say that the sooner they can be made to do so the better will it be for all concerned. I know too well how deeply rooted this long credit trading is in our industries and I should like to see it altered.

RECENT INNOVATIONS IN JEWELRY.

Turning from the trading to the *trade*, I find that a marked change has come over the style of jewelry most in demand. Bright goods are at present most fashionable, while a short time ago colored and gilded were all the rage. The change is a desirable one, as the "polisher" has not been so much in the ascendent for some time. As to new patterns I have not noticed many specimens that call for special remark. One decided novelty however has been exhibited in the shape of a lace pin consisting of an enamelled daisy with a diamond centre representing a dew drop on the flower. The intro-

duction of the diamond has a very natural effect, another floral imitation is a necklace composed of violet blossoms mounted on gold, while pearls flowing from a golden "horn of plenty" are effectively mounted as a scarf pin. A Birmingham firm, Messrs. Vaughton & Sons, have registered a good design for a challenge shield. It is to be 24 in. by 18 in. The design is such that the shield may be easily adopted for a competition trophy for almost any sporting or other association. The group surmounting the shield is a well modelled representation of St. George and the Dragon. The centre piece is surmounted by the two figures health and strength. These and the group mentioned before are executed in high relief. A spray of laurel worked in an intertwining scroll runs up each side of the

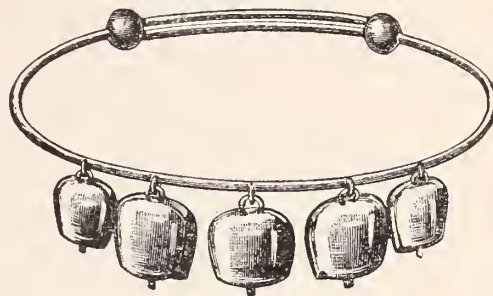

ALPINE BANGLE.

shield. The scroll and the small shield at the bottom are intended for the name of the winner, or some other inscription to be engraved thereon. The centre piece is for the introduction of some special device, according with the object for which the shield may be required. If for instance it is for a bicycle race, such a race may be depicted on the centre and it may be surmounted by a winged wheel. If it is intended for a rowing match, the shield may have a nautical device, and surrounding, while for football or cricket contests, emblems that have special reference to these games may be appropriately introduced. Considerable ingenuity has been exercised in the production of this interchangeable design and the modelling, carving, and chosing are executed in the best style.

THE ALPINE BANGLE.

Amongst novelties I may mention some new devices for bangles. One of the most appropriate consists of a series of miniature bells, of various tones, suspended from the bands of the bangle. These



CHALLENGE SHIELD.

can be made with any number of bells to suit the taste of the wearer. This "Alpine" Bangle is the production of Messrs. Booth Bros., of Birmingham, who I believe are also the manufacturers of the Alpine Bell Brooch. Another novelty in bracelets is a favorite motto engraved (to order) on the brooch or bracelet. If the article is a silver one the motto is engraved in black.

THE DIAMOND MARKET STILL FIRM.

Sales on the diamond bourse are still moderate. The fact is,

prices keep too high to render any dealings profitable for present purposes. We have had Dutch and many other foreign buyers in London lately, but no great sales have taken place. As to our supplies from Kimberley, the mines there have been to a great extent consolidated and many of the largest mines are in the hands of the De Beers company.

THE CRAZE FOR THE ANTIQUE.

The craze for the antique has taken strong hold of the lovers of gold and silver plate. The rage for antiquities with us in Britain is almost as old as the antiquities themselves are supposed to be. It is a great deal older than they really are. Old books, old chairs, old tables have long been in great demand and numbers of workmen have no doubt been kept busily engaged in the manufacture of them. And now old jewelry and especially old plate, is once more to the front. Old plate is taking its place in the affections of lovers of worm-eaten furniture, old door keys, mediæval bellows, warming pans and brass fenders of the fourteenth century, and gilt flambeaux of the days of Louis the XIV. And you will not be surprised that with all our resources of modern mechanical appliances, the supply is quite equal to the demand. I purposely introduce this subject today because I have heard on good authority that your countrymen over here have done something to revive this taste or fancy, or what ever it may be called. Whenever there is a demand for any special thing in London, there is sure to be a supply of it. Some years ago there was a demand for Chippendale, later there has been a demand for Bartolozzi, at first there was a limited supply which brought fabulous prices: *now there is an abundant supply of both*. Although I am writing to a trade journal I am not unmindful that there is a *moral* to this statement. Great frauds have lately been discovered in *old silver* supplied to dealers and pawnbrokers. If experienced persons can be deceived, private purchasers should be careful. But unfortunately people don't like to be told this. Many who cannot in the least tell whether silver is good or not, are satisfied that they can tell when it is old and that appears to answer as well for them. They point exultingly to the Hall-mark, with the assurance that there is no getting over *that*. And as the letter in mark indicates the reign of Queen Anne, they are satisfied. London is said to be (figuratively) *full of Queen Anne plate at the present time*. The revelations show that in many instances a *little* piece of real Queen Anne is obtained, the mark is cut from it and is set into a much heavier piece of the present age. The man *who knows all about Hall-marking* buys the treasure and is satisfied. There is a moral to this also. People who know more than some of us in the trade do about Hall-marks, should endeavor to add to their knowledge a little information about the silver upon which they are stamped.

CLERKENWELL'S JEW INDUSTRY.

A new trade has been added to the industries of Clerkenwell, which as far as I know does not exist on your Continent, and which will prove of benefit if introduced among your people. Its object is to supply finished set-hand arbors for hollow centre pinions. The squares are true and well polished, and the arbors altogether satisfactory. But as finished set-hand arbors would be of little avail without brooches of exactly corresponding taper to open the pinions with, measures have been taken to make opening cutters as well. These set-hand arbor brooches are of new construction, the straightened wire lying on a firm bed and being ground by a mill charged with emery. One end of the wire is nipped in a chuck on the rim of which are five notches, and as one face of the brooch is finished the chuck is turned one-fifth of a revolution, subjecting another part of the wire to the action of the mill in order to form the next face, and so on till the five faces have been cut. This new industry will prove of great convenience to watch repairers.

VIGILANT



[FROM OUR SPECIAL CORRESPONDENT.]

CHICAGO, October 20, 1889.

If there is any wholesale jeweler in Chicago who finds time hanging heavy on the hands of himself and his employes, he should at once stir his stumps, for he is one of those exceptions proving the rule. Never before at this season of the year were the jobbing jewelers so busy as during the past few weeks. The season has now so far advanced that the daily increasing business runs so systematically and smoothly that no more effort is apparent than in July or August. All hands are too busily employed for much talk or noise.

The present trouble between Chas. B. Helfenstein and his employers is quite similar to last year's trouble between Helfenstein and Geo. H. Rosenblatt, just now pending in the Chicago courts. In the summer of 1888 Helfenstein agreed to represent Rosenblatt in the West on commission, and is said to have drawn \$500 at different times, and also to have received a through ticket from the West with intentions to return with the samples at once. Instead of returning Helfenstein secured an attachment on the goods on the ground that he had been hired on a salary. Mr. Rosenblatt attempted to have the attachment vacated, but this was denied him, and the case was appealed to the Superior Court, where it is now pending.

Another case just now having the attention of the courts is that of William Williams, the retail jeweler on South Halsted street, who is under \$1,000 bonds to answer to the charge of using the mails for fraudulent purposes. The retail jewelry store, not having attracted sufficient trade and not having brought a return of very much profit, he advertised wonderful bargains in watches through the mails and newspapers. The Swedish and Norwegian newspapers were the ones most favored with this advertising, and knowing that his own name had too great notoriety to secure patronage, he assumed the name of N. A. Erickson, and this fictitious cognomen he signed to all letters asking for information. In his advertising he guaranteed the watches worth \$15, and offered them at \$5. They were to contain Trenton movements and Dueber cases. On this plan he did a rushing business for awhile, but no sooner were his goods delivered than complaints came pouring in to the post office. The authorities were unable to locate Erickson until A. J. Johnson, editor of the *Svenska Kurien*, brought to them an advertisement and asked that it be investigated. This notice had been refused by Mr. Johnson, who sought to protect his people, and from it Government Inspector Fleming thought that Williams was concerned in the fraud. After carrying on a correspondence with the jeweler, Fleming bought one of the watches in the regular way, and then caused Williams' arrest.

If the piece of mechanism purchased by Mr. Fleming is a fair sample, the rest of Williams' customers have been frightfully swindled. The back looks like the top of a well polished blacking box, and when the works inside can be induced to move they make more racket than a good sized alarm clock. Instead of being worth \$15 as a time piece, it would very well serve the purpose of a ten cent paper weight. This watch will be examined in the case against Williams. It was not accompanied by the promised guarantee, and was minus the stamp borne by all Dueber cases. The works are of the cheapest that can be made, and the whole thing, according to the estimate of a practical watchmaker, was produced at a cost of \$3.29. Williams will be tried under the newly passed postal laws, prohibiting the use of fictitious names in mail matter for the advertisement of goods. Williams makes the statement to your observer that it is all the work of some enemy. He says he will be able to

explain everything satisfactorily when the matter comes to trial.

The watches sold he claims are worth all that was paid for them. He acknowledges that they are not in Dueber cases as advertised, but says the cases supplied are just as good and made of the same material. The substitution of the new cases in place of the Dueber was necessitated by the formation of the watch combination, so he says, but his having served time on a similar charge before, induces little confidence in any of his statements. In fact he is none other than the old "Solar Watch" man who was nipped by the post office inspectors seven years ago. The "Solar Watch" scheme was originated by Williams and was practiced on ignorant people, who were led to believe that they could obtain a reliable watch for almost nothing. Williams advertised principally through the newspapers, and always under an assumed name. His "Solar Watch" advertisements stated that he would send a valuable timepiece to any person who would forward his address and an accompanying payment. People who were induced to make payments received a day or two after nothing more nor less than an ordinary sun dial. This swindle was successfully practiced for a time, but was finally the means of landing its originator in the penitentiary for a number of years.

The Chicago *Herald*, under date of Oct. 20, pays the following handsome compliment to our largest jewelry establishment:

"The return of Henry A. Spaulding to the head of affairs at the State and Monroe street jewelry establishment has marked the opening of a greater number of precious stones, set jewels, Parisian *nouveautés*, rich pottery and beautiful pieces of dainty furniture than has ever before been seen in this city. Frequent as, indeed, have been the expressions of surprise that Spaulding & Co. or any other house should venture the collection of so great a quantity of high-class objects, the firm's confidence in the appreciation which they are meeting with is unshaken, and every day will add to the exquisite creations in what is, indeed, the treasure house of the West."

The Justice Jobbing Co. had scarcely begun business, as reported in your Observer's column of September, when it made an assignment to A. P. Ingram. Six weeks was the extent of its life. As for the assets and liabilities they are about equal, each being about \$3,000. When the company was incorporated in August the capital stock authorized was \$50,000, and the concern was to be devoted to the jobbing of cases and movements. Mr. Justice, the President, and Mr. Fitts, the Vice-President, were formerly agents of the Phoenix Watch Co., at Wheeling, W. Va., and having had considerable trouble with the company there last spring they left and came to Chicago. The assignee states that the creditors will receive the full amount of their claims, but this is taking a rather sanguine view of the matter.

The Blauer Watch Case Co. had a very narrow escape from loss by burglars last week. The robbers were discovered by the watchman on duty, who fired upon them, and whose fire was returned, but they were finally driven off, having secured nothing.

The stock of Max Young brought \$11,500 at sheriff's sale, which is enough to satisfy all the judgment creditors, but leaves nothing for those whose debts are unsecured. It is the opinion of the trade here that the stock brought about 85 cents on the dollar, quite all it was worth.

H. C. Ebersole, a jeweler of Logansport, Ind., has failed with liabilities of \$18,000. No cause is reported here as yet. L. W. Berry, of Carthage, Ill., is on his wedding tour.

The Elgin National Watch Co. are still behind on their orders, and their new illustrated catalogue would in view of this fact seem needless advertising. It is, however, receiving many compliments from the trade here, especially that portion of it illustrating fancy watch dials in black and colors.

The J. E. Winzer Co. has been incorporated here with a capital stock of \$6,000, for the expressed purpose of manufacturing watches and jewelry. Julian Kune, J. E. Winzer, and J. E. Bogart figure as the incorporators.

James O'Rourke, who was formerly employed by the Rockford Watch Co., Rockford, this State, has become insane, and the case is

an especially pathetic one. He was a young man of whom everybody spoke well, and so attached to his widowed mother and his brothers and sisters, who depended on him for support, that his mind gave way through fear of his inability to properly care for them.

The Chicago Jewelers' Association Collection Department is still increasing in efficiency, and the members are well pleased with the good work done; the feature that has been found most useful is the letter sent to delinquent debtors, which contains all the names of the members, including nearly every jobber of whom the debtor would require to purchase. The delinquent retailer realizes that his credit with the entire trade will be impaired unless he makes every effort to pay the liabilities, and hence the moral influence is most effective.

Mr. H. S. Peck, Manager of the Waterbury Clock Co., who is one of the solid men to whom your observer looks for information concerning the trade, reports collections good and the trade greater in volume than last year.

In fact all the clock companies seem well satisfied with the condition of trade. Morse, Mitchell & Williams, Western agents for the E. N. Welch Clock Co., are finding an especially large sale for the new solid wood cases in the old drop octagon, 12-inch dial, shape. Each of these new cases is of solid bird's eye maple, old oak or mahogany, and the cost is but 25 cents more than the common and unsubstantial veneered cases. Black enameled wood mantel clocks seem also in high favor. Morse, Mitchell & Williams are also the sole agents here for the Dueber cases and Hampden movements.

Among the new things shown by the E. N. Welch Clock Co. are musical clocks which play a tune every hour, but what has occasioned more pride than any other one feature of the business in the Western agency is that the thirty-day regulators placed throughout Chicago and the West during the past two years have proven unequalled as reliable regulators.

M. N. Burchard, Western manager for Simpson, Hall, Miller & Co., is a very active member of the committee on National Co-operation for the securing to Chicago of the World's fair, and it takes a mighty big customer for this firm's standard goods to keep him away from attendance on a world's fair meeting. Mr. Burchard states that the recent stiffening of prices on all "Rogers" ware has been well maintained, and that the orders which for a time were delayed in the hope of a resuming of the old discounts are now coming in thick and fast at manufacturers' present prices.

The Gorham Manufacturing Co.'s new 62-page catalogue showing illustrations of the fall novelties in sterling silver small wares, as well as their 28-page catalogue of spoon patterns is attracting much favorable comment from jewelers here. The only trouble is that the Gorham people cannot catch up with their orders.

The Meriden Silver Plate Co. are doing a large business in silver tea sets, which have again swung round into general use. Over thirty beautiful designs are shown by this one house in their ware-rooms here and the sales prove that pressed glass, and more especially colored glass, has been superseded by silver plate. Silver candle sticks and candelabra are also forming an important feature in silverware sales. One entire show window of the Meriden Silver Plate Co., is filled with them.

Speaking about window decorations, the show windows of Spaulding & Co., have attracted great attention during the month. In one window are exhibited views brought back from the Paris Exposition by H. A. Spaulding, who as the representative of this state at that world's fair has had unequalled opportunities of noticing and collecting all novelties in the line of his chosen business. Another window is filled with seventeen prize cups to be awarded at the American Horse Show, which opens November 1st. They are all made of Gorham Sterling Silver, and the fact that the orders for all of these, each being given and bought by different persons, should be awarded to this one house speaks volumes for the estimation in which Spaulding & Co., are held.

There are perhaps no jewelers in America more alive to the value

S. Cottle Co.'s New Patent Button.

One Piece, Seamless, Solderless, and without an Opening into its Interior.

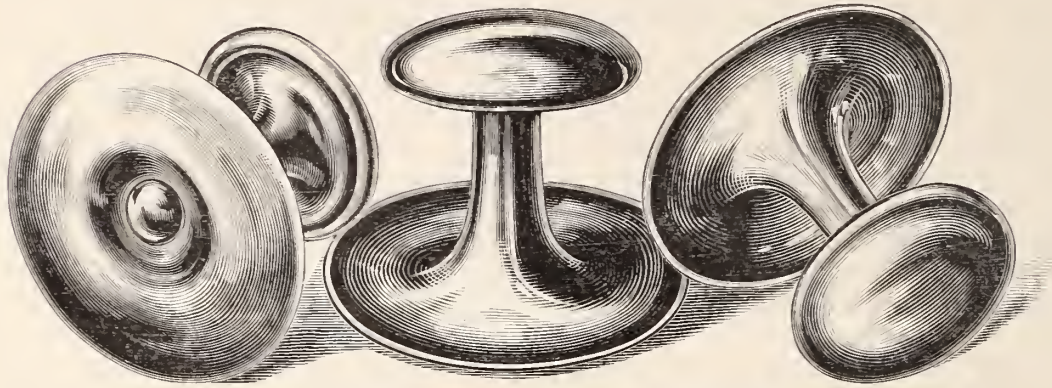

Construction Patent, March 6, 1888
 Design " May 22, "
 Process " June 5, "



STOKES PATENT,
 by Court Decision, owned
 by S. COTTLE Co. since
 1884, as per letter below.

Krementz & Co. vs. S. Cottle Co.

EXTRACTS FROM THE DECISION OF JUDGE WALLACE:

"That the complainant was not the first to make a hollow stud, or a hollow stud from a single piece of metal, or a stud from a single continuous piece of metal, or a partly hollow stud from a single continuous piece of metal. * * * * The idea and the method of making a seamless stud out of a single continuous piece of metal was suggested and fully shown by the patent of Stokes.

The Stokes Patent is and has been owned by S. Cottle Co. years before this suit was commenced. For full decision, see July number Jewelers' Circular, page 83, or

S. COTTLE CO., 860 BROADWAY, N. Y.

P. O. Box 1679.

LANGDON, BATCHELLER & CO.,

345 & 347 Broadway.

MANUFACTURERS OF

GLOVE FITTING CORSETS. CLASPS, Etc.

NEW YORK, Oct. 16, 1889.

MR. S. COTTLE,

860 Broadway, City.

DEAR SIR:—By request of yours this day, we send you the following:

We sold you, under date of Sept. 25, 1884, the exclusive right in the Stokes Patent No. 171,882, dated Jan. 4, 1876, for Gold and Silver and Gold and Silver Plated Jewelry. We also sold to Messrs. Krementz & Co., under date of Sept. 26, 1889, all the remaining rights in said Patent which in no way relate to Gold, Silver and Plated Jewelry.

Yours respectfully,

Langdon Batcheller & Co

THE TRADE MAY DRAW ITS OWN CONCLUSIONS.

TO THE TRADE:

We desire to correct false statements in advertisements which have appeared in this and other Journals for the past few months to the effect that

"The Stokes Patent is and has been owned by S. Cottle Company years before this suit was commenced."

The Stokes Patent is now owned by us; it is not and never has been owned by them, which Messrs. LANGDON, BATCHELLER & CO., the former owners, fully acknowledge as follows:

NEW YORK, OCT. 24, 1889.

MESSRS. KREMENTZ & CO.,

GENTLEMEN:—Regarding the ownership of the Stokes Patent, would say we have read the decision of Judge Coxe in the case of Cottle vs. Krementz, Nov. 13, 1885, to which you call our attention, in which he says:

"that the complainant (Cottle) has a license to use the patent for a specific purpose; that the legal title is in Thompson, Langdon & Co."

We, as their successors, having sold you the patent outright, this decision evidently settles your respective interests in it; making you the owners and Cottle licensee.

Yours respectfully,

LANGDON, BATCHELLER & CO.

In same advertisement also appears a cut of a sectional view of our One Piece collar button



which is marked "Stokes Patent." To show the falsity of this we append a fac-simile cut of the "Stokes Busk Fastener" as it appears in the official Patent Office Records, from which it will be seen that the one shown in advertisements is not a cut of the Stokes patent, nor did the court so decide.

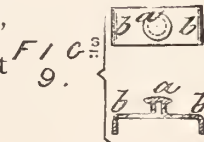

KREMENTZ & CO.,

182 & 184 Broadway, New York.

of show window attractions than are those of this city. Joseph & Fish attract much notice in this way and scarce a day passes which does not see some novel feature introduced by them. Yesterday a great silver spider web spread its gauzy net work quite across one of their windows with here and there some jeweled novelty imbrued in it. Near its centre a giant spider fashioned of gold completed the attraction, which so charmed those who saw it from outside the store as to lead them to "Walk into my parlor" where not many escaped before making a purchase.

The new San Diego pattern introduced recently by Simpson, Hall, Miller & Co., is meeting with more popularity here than any pattern they ever introduced in plated goods. The design consists of a series of corrugations with rows of bead work between them.

Prominent among the out of town jewelers noticed in Chicago by your observer recently are J. F. M. Decker of Oshkosh, Wis., who was recently burnt out, has collected his insurance and is now buying a new stock; A. B. Harford, who is just opening a new store in Detroit, having removed from Saginaw, Mich.; Mrs. Pilcher, Plainfield, Ill.; H. L. Price of Presco, Ill.; O. Kleinfelder of Musquoketa, Iowa; F. M. Riley of F. M. & A. G. Riley, the leading jewelers and druggists of Jefferson, Iowa; Chas. Walden and wife, Burlington, Iowa; F. C. Cook and wife, Janesville, Wis.; F. W. Lamphere, Ovid, Mich.; Mr. Floyd of Floyd, Jenks & Co., Elgin, Ill.; Mr. Meissner of LaGrange & Meissner, Druggists and Jewelers, Reinbeck, Iowa; Gustav Schleuder, Austin, Minn.; C. A. Smith, Emmetsburg, Iowa; O. C. Retsloff, Winnebago City, Minn.; J. L. Escher, Clarence, Iowa; J. W. Dikob, Charleston, Ill.; L. Streiche, Kansas City Mo.; the three Thoma Bros. of Kalamazoo, Mich., Three Rivers Mich., and Battle Creek, Mich.; B. P. Richmond, Lansing, Mich.; J. Bazinski & Brother, Miles City, Mont.; Henry Bohm, Denver, Colo.; A. G. Earle, Colorado Springs, Colo.; Jos. Dikob, Charleston, Ill.; T. B. Myers, St. Paul, Minn.; Chas. Karston of the C. Preusser Jewelry Co., Milwaukee, Wis.

THE CIRCULAR'S OBSERVER.



[FROM OUR SPECIAL CORRESPONDENT.]

MINNEAPOLIS, Minn., Oct. 12, 1889.

Local manufacturers, retailers, and jobbers in jewelry in and about the twin cities are all deeply interested in the movement organized by the various Jobbers Associations against the growing practice of the manufacturers selling direct to the retailers. In Minneapolis and St. Paul the feeling is especially strong because so little manufacturing, comparatively is done here, and the jobbers lose heavily by consignments from Eastern manufacturing houses. At present the manufacturers here are decidedly independent, the jobbers determined, and the retailers, generally indifferent so long as prices are not affected. Developments are apt to be interesting.

A. J. Warner & Co., report business as good and steadily working up. Their recent country trade has been large but collections are still difficult. Warner & Co., though not members of the Jobbers' Associations approve of their course. They think it the best thing for the retailers that could happen.

Two new Minneapolis firms are H. E. Murdock, wholesalers, and L. E. Clausen & Co., jewelers' supplies. Both have rooms in the new Bank of Commerce Building and both have started out auspiciously in the fall trade.

Secretary Windom has informed Moses Kitzler of Minneapolis that the jewelry imported from Europe as wedding presents to him-

self and wife are not entitled to exemption from duty and he cannot authorize its free admission.

In Kansas City, Mo., Mrs. M. C. Baker the widow of the late jeweler, accused a real estate agent named Rogers of having swindled her out of diamonds and other jewelry to the value of \$1,306. She says that Rogers, who had been authorized to dispose of her stock, brought her notes, etc., in trade. While her attorney was examining these, Rogers borrowed the jewelry to show the intending purchaser across the line in Kansas City, Kan. The notes were found to be worthless and she has brought suit against Rogers and his alleged confederate Ingram for the recovery of the jewelry.

Considerable surprise was occasioned by the assignment of the prominent jeweler H. J. Goddard of Chippewa Falls, Wis., Sept. 16. The full liabilities are not known but the assets will more than cover them, though much of it is real estate and cannot be immediately realized upon. C. H. Knights & Co., of Chicago are the heaviest creditors; their claim is about \$7,000. They started other creditors and four attachments were served on the property. The Seymour and the Lumberman's Banks of Chippewa Falls are among the creditors. He offers 60 cents on the dollar.

Fred. Correll is building a new store and will engage in the jewelry business at Welcome, Minn.

Ed. Crane is negotiating for the re-purchase of the jewelry store at Granite Falls, Minn., which he sold about a year ago.

W. J. Keating of Watertown, S. D., has bought the jewelry business formerly conducted by W. R. Arnold.

F. C. Stamm has re-located at Princeton, Minn. He sold out there and went to Monticello about two years ago.

H. C. A. Ledgerbloom of Motley, Minn., has removed to Sauk Rapids where he will put in a stock of jewelry.

Davidson & Bros, jewelers, Calgary, Alberta, and Vancouver, B. C., are closing up business at the former place and moving out their stock. They will open a store at Victoria, B. C.

L. E. McClees & Co., have opened a jewelry store at 25 West Granite st., Butte, Mon.

A. Beinhorn has purchased a stock of jewelry in the East and will open a store at Winona, Minn.

Crane Bros., jewelers of Lake City, Minn., have a clock over one hundred years old which is still capable of methodical business.

The Minneapolis *Tribune* says of G. Schlender, the Austin, Minn., jeweler, "that he is an old settler and one of the fathers of the city. Probably no man in Austin is identified in so many business enterprises as Mr. Schlender."

The bill of the Seth Thomas Clock Co., for the clock in the tower of the fine new court house at St. Paul, as allowed amounted to \$2,915.

The Black Hills Jewelry manufactory has just turned out a number of sets of handsome native gold jewelry with pure quartz settings. The settings are in themselves handsome and valuable, being as clear as crystal and exhibiting free gold in their center.

The Berthiaume Jewelry Co., which has done business in two or three different Northwestern cities has consolidated its two stores at West Superior and now has a fine establishment at the head of the lake.

HENDERSON.

THE LAP FOR POLISHING—Those who have much experience in polishing, may with advantage use a lap for straight pivots and shoulders. The lap and pinion are rotated in opposite directions by means of two bows held in the right hand, the lap being centered in the back limb of a depthing tool, and the pinion in the front one. An arm is fixed to the depthing tool to hold it in the vise by, and a piece of brass wire clasps the rudders of the front limb, so that the operator can move the pinion to and fro with his left hand. A soft steel lap at first and a zinc lap afterward are generally used. They should be turned true on the edge and the face slightly undercut.



ANCIENT EGYPTIAN NECKLACE.—It is a chain of exquisite gold, a rich orange yellow in color, with links dextrously twisted one upon another. It is about thirteen inches long, three-eighths of an inch wide and as nearly a tenth of an inch thick as I can measure it with a rule. The ends of it were at first fitted only with small solid rings set into clamps beautifully ornamented with leaf-work. Perhaps it was fastened to the wearer's neck by a filament or cord silk tied through. The present owner has arranged a modern clasp in the shape of the lotos flower. It can still be used—and, indeed, as well as ever—as an ornament for one in fall dress. It is so flexible, falling down into picturesque folds the moment it is let go, that it seems more like a ribbon of delicate tissue than like mere metal. An expert goldsmith told me, after he had examined it with his glass, that it undoubtedly had a perfectness of uniformity in the links which could be found only in a chain manufactured by machinery. This was to me a matter of wonder, for I was not prepared to learn that the ancient Egyptians had the knowledge of machines which could produce woven fabric from pure gold. It was at once a discovery and a delight. The necklace, according to all probability, belonged to some princess, and dates to about the time of Moses, if Herr Brugsch is correct; it was found in one of that range of tombs opened along the Nile, where royal and priestly burials were frequent.

DIAMOND UNGUENT.—*Le Moniteur de la Bijouterie*, etc., reports a case of swindle. It says that the police court of Dijon had recently an interesting case before it in the persons of two Hindoo doctors, who had recently arrived from Delhi in company with an old English soldier. They pretended that they could cure all the diseases of the eye with a salve composed of more ingredients than the famous witches' cauldron in *Macbeth*. The principal constituent, however, was a diamond of about four hundred francs in value, which the invalid had to purchase. This diamond was apparently melted in his presence, together with the other ingredients. These unsophisticated disciples of Brahma forgot, however, that France was not exactly the best spot for such swindles. Their interpreter escaped, and for some days the case could not be prosecuted for want of another interpreter, until finally one was found who had been for a number of years the head gardener of some rajah. He was kind enough to inform them that they had been sentenced to six months' imprisonment.

TOUCHING SYMPATHY.—A touching token of sympathy for their most beloved Czar (perhaps to avoid the danger of being sent to Siberia) has been evinced recently by the "*allerunterthanigste*" clergy of the diocese Khartoff, Russia, in remembrance of the remarkable escape of this God-annointed personage and his family from the railroad disaster. This memorial consists of a solid silver clock, which is set up in Khartoff in such a manner that its dial points exactly in the direction where the accident occurred. The clock strikes once every twenty-four hours, to wit, at the same moment when the accident occurred, after which it rings a bell for five minutes.

EXHIBIT OF DIAMONDS.—On the Quai d'Orsay, Paris, is a splendid exhibit of diamonds in the pavilion of the Kimberley Mine, South Africa. The building represents an old Dutch residence of the seventeenth century. Going inside, will be observed a large, round window, in which are displayed diamonds in their natural state as they are taken from the mine, diamonds half cut, etc., with the articles used in cutting and polishing them. Also, several objects holding diamonds, such as a diadem, in the center of which is a triangle made of three diamonds which are worth \$20,000 each; a handsome wreath, a brooch, necklaces, a cross, etc.

THE SHAH OF PERSIA.—At the visit of the Shah of Persia to Waddesden Manor, the country seat of Baron Ferd. von Rothschild, he inspected all the treasures and antiquities of the Baron, but was pleased most with a jewel-set mantle clock, which is a veritable work of art. The central figure of this clock is that of an elephant, which, when the clock is wound, begins to wag his golden tail, move his jeweled trunk, shake his large ears and turn his small diamond eyes; thereupon the lotos flowers, formed of jewels, at his feet, begin to open, a procession passes by, and from under the enameled leaves of the bushes snakes and other reptiles crawl out. The Shah was exceedingly charmed with this costly toy, which had constantly to be wound again for his delectation, and his behavior demonstrated that the illustrious shahen-shah preferred it to all the treasures owned by Rothschild. Artifices had finally to be resorted to to attract his attention to other things, for fear that he might express a desire to possess it.

PUBLIC CLOCKS.—The proper authorities of Berlin, Prussia, have resolved to set up clocks, after Mayrhofer's system, on seventeen public places in that city, the places to be designated hereafter. The cost per clock has been fixed at 4,000 marks, and its attendance 279 marks per annum. The gas for lighting the dial, as well as the water necessary for actuating, will be furnished by the city free of charge.

THE BIGGEST GOLD NUGGET.—There have been big gold nuggets found in various countries, but the largest ever discovered was found in New South Wales, Australia, on May 10th, 1872. Its weight was 640 pounds, height, 4 feet, 9 inches, width, 3 feet, 2 inches, average thickness, 4 inches, and it was worth \$148,800. It was found embedded in a thick wall of blue slate, at a depth of 250 feet from the surface. An interesting feature of its history was that the owners of the mine were living on charity when they found it.

SAPPHIRE.—There was in the Ancient Hungarian crown a fine large sapphire, surrounded with four oblong green gems, the nature of which has not yet been made known. These mysterious green stones, rendered still more interesting by the disappearance of the crown, are perhaps of modern introduction, as they are not mentioned in the inventory of the jewel, when Queen Elizabeth pledged it to Emperor Frederick IV. Hence the inquiry arises—are they green sapphires, emeralds, tourmalines or antique glass?

SILVER JEWELRY IN ENGLAND.—Some eight or nine years ago, silver jewelry became fashionable in England and many of the goldsmiths, who were then doing a poor business, at once gave their attention to it, and it at once became most popular and fashionable both in Great Britain and her colonies. Indeed, the demand was so great that the supply could not keep pace, and it seemed as though the trade had taken a new lease of life; everybody was doing well. The public, appreciating this cheaper class of jewelry of intrinsic worth and a precious metal, availed themselves of it everywhere. Every female wore bracelets, necklets, lockets, brooches and earrings, etc., and of a size and weight that would to-day be considered "extremely vulgar." The novelty craze was "on," but novelty crazes are somewhat like poker playing: it doesn't cost much to go in, but it takes every cent a person has to come out. The craze was short-lived, and left dealers with stocks worth little fortunes in store, to deplore the fickleness of fashion. Moral to retail dealers: Beware of novelty crazes!

RESTITUTION.—A clergyman recently presented himself before a criminal judge in the city of Paris and said that one of his female parishioners, who had declared herself to be a miserable sinner, had stood in intimate relations with Prado, who had given her various presents in the form of jewelry. She, however, had not known that her lover was a criminal. He had paid his debt to human society, and she was plagued with scruples of conscience to keep the booty of an assassin, and therefore turned them over to the proper authorities. The different articles were then advertised, and will soon be restored to their proper owners.

Advice to Watchmakers' Apprentices.

BY A MAN WHO HAS SPENT TWENTY YEARS AT THE BENCH.

THERE are many workmen who hesitate about taking in verge watches to repair for the reason that they do not understand the escapement. Relic hunters are bringing up these watches again, and workmen can now get good prices for repairing them; consequently this is a good incentive to understand their escapements. The verge escapement is comparatively simple, and if one will but go to work in a systematic manner it can readily be put in order. There are two marked varieties of the verge escapement, the French and the English; both are in principle the same, but the mechanical details of construction are quite different.

We will first consider the English system of construction. These watches usually have a broad cock extending entirely across the balance, with a regulator working in a toothed segment by means of a flat pinion operated by the winding key. The mechanical principles of this part are so evident as to require no description or comment. The top and bottom pivots to such watches usually run in brass bushes which are drilled into the cock or potence and a hole drilled into the cock bush of the proper size to receive the pivot. The name of the part which holds the lower end of the verge is called the "potence," and the stud which holds the outer end of the pinion which lies horizontally is called the "counter potence," and the plug which goes into it for holding the outer end of the pinion is called the "follower." The escape wheel, which many call the crown wheel is properly termed the "balance wheel" or verge wheel, and what workmen usually term the balance wheel is simply called the

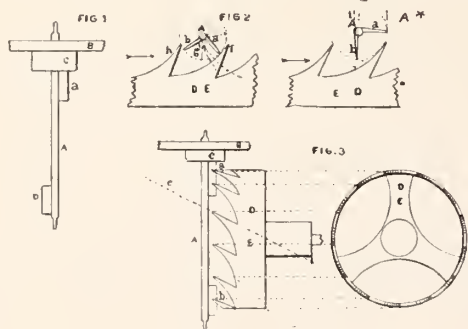

"balance" or pendulum. The fourth wheel, with the teeth extending upward parallel to the pinion arbor, is called the "contrate wheel." The end of the balance wheel pinion, which is at the potence, runs in a movable brass slip called "dovetail slide," which can be moved right or left to equalize the action of the teeth of the escape wheel on the pallets of the verge. In this communication, the principles involved will be considered more than the methods of repair, leaving that matter for subsequent consideration. The verge escapement, like the majority of others, has been more or less modified and changed by most of the prominent makers, the general mechanical principles remaining the same. The original verge escapement was first employed in clocks, and the pendulum given a very large arc of vibration; and when first employed in pocket watches was used without a spring to control its action. This accounts for the name "*pendulum spring*," which is still employed by many horological writers at the present day. Any good verge watch will run without the "pendulum," "balance" or "hairspring," as we choose to term it.

A few words about the names of parts of watches, including the name of the spring which controls the action of the balance. All our material houses catalogue them as "hairsprings;" in our factories they are discussed as "hairsprings," and if a customer comes into your place with a watch in which the "*balance spring*" is not fit to perform its function, you will tell him it needs a new "*hairspring*," consequently let us accept the name of "hairspring" as one we all understand. I have given the generally accepted names for

the various parts of a verge watch for the reason that most of our younger workmen are usually entirely ignorant of them. The escape wheels of this escapement have either 11, 13 or 15 teeth, but the writer has seen a few French verge escapements with 17 teeth. The verge or arbor on which the balance is mounted is a slim stud spindle with two pallets attached, as shown in fig. 1, where *A* shows the verge arbor and *a b* the pallets, *B* the balance and *c* the seat for the hairspring collet. Fig. 2 shows a view of the pallets seen in the direction of the axis of the verge with the balance removed. The faces of the pallets are radial to the verge axis and stand to each other at an angle of about 95 degrees. This angle varies with different makers from 90 to 115 degrees, but the angle of 95 degrees seems to be the one most generally adopted. The inner angle of the escape wheel teeth is usually cut at an angle of 25 degrees to the axis of the escape wheel pinion, as shown at the dotted line *e*. The curve at the back of the tooth takes an inward direction so as not to interfere with the action of the pallets. The action of this escapement will be understood by inspecting carefully the cut at fig. 2. In this cut, the pallets *a b* are represented as standing at rest, and the tooth *f* as having just escaped from the pallet *a*. The tooth *g* on the opposite side of the escape wheel would engage the pallet *b*, and the acquired momentum of the balance would cause the pallet *b*, in contact with the tooth *g*, to force this tooth a little backward, this action producing the feature which has given the verge escapement the appellation of a recoiling beat; although, in strict truth, we have only a few absolutely dead beat escapements, among which are the cylinder and the old rack and pinion lever. The modern detached lever and detent escapements have a slight recoil from the "draw" of the locking faces. The impulse angle is supposed to be about 20 degrees on each pallet. The entire width of the pallets is calculated to be a trifle more than one-half the space from tooth to tooth of the escape wheel. As, for instance, in diagram *A**, the points of the teeth *h f* are 46 one-thousandths of an inch apart, and the diameter of verge staff is 11 one-thousandths, and we make the entire width of the pallet *a* 25 one-thousandths, we have, after deducting $5\frac{1}{2}$ one-thousandths for the semi-diameter of the verge arbor, $4\frac{1}{4}$ one-thousandths as clearance between the tooth and pallet. A verge escapement when in good order should give from one-third to two-fifths of a revolution to the balance; or, to speak more accurately, from 120 to 160 degrees. A hairspring for a verge watch should be chosen of open coils, and should not contain more than six coils. Such a spring is desirable for two reasons: first, it allows the regulator to have more relative power over the watch, and in the second place a hairspring in which the spaces between the coils gradually diminish gives better results than one in which the coils are equi-distant, and closer together. While it occurs to the writer, it is well to say that a proper mainspring is of vital importance to the good performance of a verge watch; as it is imperative to have the power exerted exactly the same at the commencement as at the end of the action, or, to phrase it a little differently, have the spring exert the same force when nearly run down as when first wound up. This is to a great measure accomplished by the fusee, but it also depends much on the nature of the mainspring. A mainspring for a verge movement should be rather weak and thin so the barrel will readily contain thirteen coils of spring and give five to six full turns of the barrel arbor. It is well to remind the reader that verge watches are not accurate timekeepers—one which will perform inside of a minute in a day can be pronounced first-class—and the hanging rate and the pocket rate will also vary, these watches invariably gaining when carried in the pocket. Any violent agitation like that caused by horseback riding accelerates their rate five to ten minutes a day. In regulating these watches, therefore, when in the shop they should be regulated to lose a minute or minute and one half in a day. In my next communication I shall go into details of repair and describe more minutely the relation of the several parts. It is well when taking in such a watch to post the customer as to about what he can expect of it when put in order.

Factory Clock Showing Day's Production.

MILLS and factories run by water or steam rely on a certain production per day or week. Since, however, there are always small variations occurring with these motors, due to one cause or another, it is impossible to determine the production with absolute correctness for comparison. In order to obtain such data, various kinds of horological instruments are used, all of which, however, as far as the writer knows, are propelled by the shafting and simply record the number of its revolutions, which is in many cases highly unsatisfactory.

A foreman in a German textile mill has recently invented a simple

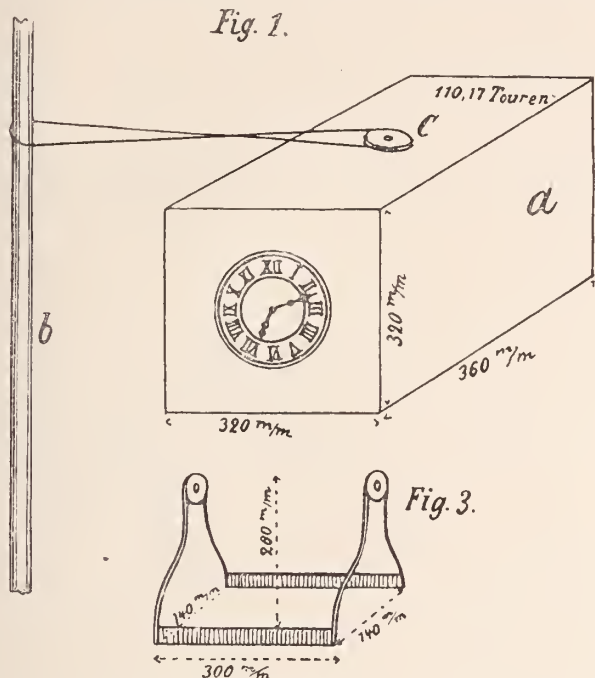

clockwork for exactly determining the loss or gain in working time ; it is of ordinary construction, with a dial and two hands, and when the mill runs at regular speed it keeps time with the office clock. But if the motor runs quicker, the dial shows how much time has been gained, and if slower, how much time has been lost. The clock is under the care of a reliable attendant, whose duty it is to record these differences every day in a time book and then set the hands again when work is resumed on the following day. Balance is struck at the end of the week, and these results will correctly inform the owner of all the data concerning the work. The clock may

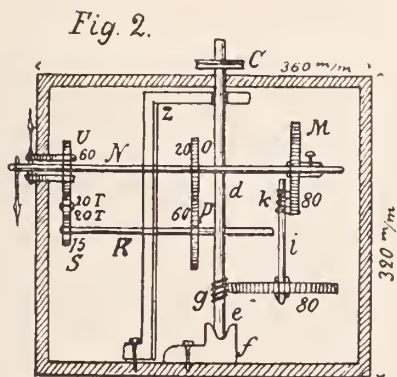

be set up in the office or at any other place, say about four or five feet from the floor, for easy manipulation.

It is described as follows : The clockwork is inclosed in a case, *a*, fig. 1. It has a dial, and an opening for oiling the train and setting the hands ; *b* is a shaft from which, by means of the pulley *c*, the clock is actuated with 110.17 turns [per minute?—ED.] The pulley *c* is keyed upon the staff *d*, of 12 millimeters in diameter, with its pivot *e* in the support *f*; above, it runs in the angular piece *Z*. Both support and angular piece are screwed to the bottom of the case.

At a certain place near its lower end, the staff is furnished with a simple worm, which drives a spur wheel with 80 teeth. This 80-tooth wheel is fastened to an arbor, *i* (the pivot of which is fastened to support *x*) ; this arbor also has a simple worm, *k*, by which it actuates a spur wheel, *M*, with 80 teeth. This wheel is also for setting the hands, and it must therefore sit loosely, be keyed upon the staff, and be furnished with a thumbscrew. When setting the clock, the thumbscrew is loosened, the wheel taken out of depthing, and the handstaff rotated with the fingers until the hands point out the correct time ; the depthing is then re-established and the screw slightly tightened. The last 80-tooth wheel sits upon the staff *N*, of 10 millimeters' diameter, to the end of which the large hand is fastened outside. The staff *N* lies in bearing *x*. The hour hand is actuated by this staff in the following manner : On it sits a 20-tooth spur wheel, *O*, which propels below a 60-tooth spur wheel, *P*, on the staff *R*, of 10 mm. diameter. This staff *R* is pivoted in two angular supports, screwed to the interior back of the case. Not far from the 60-tooth wheel is a 15-tooth wheel, *S*, which drives, by an intermediation of two 20-tooth wheels, *T T*, the 60-tooth wheel *U* upon a casson, *W*, in which moves staff *N*. The hour hand is fastened upon this casson.

The clock is very simple and practical, and can be manufactured at a cheap price.

New Compensated Clock Pendulum.

THE improvement in the manufacture of clock pendulums on which George P. Reed, of Melrose, Mass., was recently granted letters-patent, contains several features worthy of more than passing notice. The invention relates to an attachment for ordinary clock pendulums by which variations in temperature may be automatically compensated for.

FIG. 1

FIG. 2.

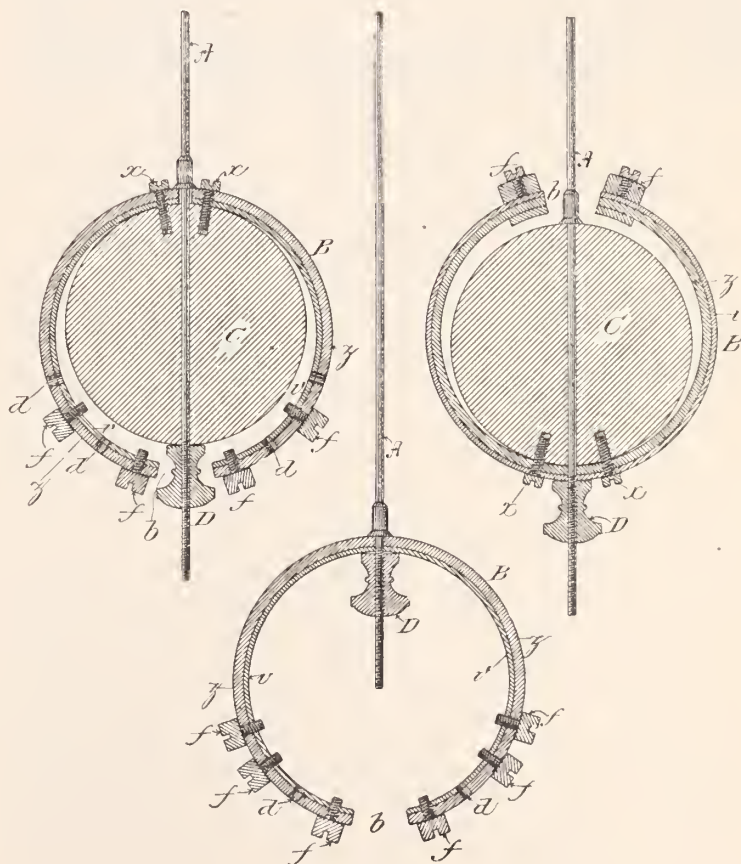

FIG. 3.

It is patent to all connected with clock manufacture that the effect of heat or cold upon the pendulum of a clock is a lengthening or a shortening of the vibrations, which causes the clock to either lose or

gain time, as it is hot or cold. To obviate this objection, it has been customary to move the ball *C* (in cut) on the rod *A* until the pendulum is adjusted. This invention provides for an accurate adjustment, automatically, in the manner demonstrated by the diagrams.

A laminary ring, *B*, consisting preferably of an inner plate of steel, *z*, and the outer plate of brass, *z* (though any contractile or expansive metals can be used), firmly united together, is secured to the top of the ball *C* by screws *x* (see fig. 1) and opened at its opposite side, as shown at *b*. The free ends of the ring *B* are provided with a series of screw holes, *d*, to receive screws by means of which weights, *f*, may be secured at different points thereon. The ring may be secured to the lower portion of the ball *C* in such a manner that its free ends project upward around the ball without coming in contact therewith, as shown in fig. 2; or, if desired, the ring *B* may be constructed of sufficient weight to enable the ball *C* to be entirely dispensed with.

The brass plate being much more susceptible to the action of heat and cold than the steel plate, expands and contracts more readily and thereby causes the free ends of the ring to move inward or outward or upward and downward to the plane of the rod. The effect of it is diametrically opposite to that upon the rod, and the weight is maintained at the same distance from the pivotal point or points of suspension of the rod, thus causing the vibrations to be at all times equal. By moving the weights *f* on the free ends of the ring their movement will be greatly increased or diminished in proportion to their distance from the free ends of the ring. The inventor says he has thoroughly tested his improvement, and claims it to accomplish its object.

A New Free Escapement.

[From *Journal Suisse d'Horlogerie*, September, 1889.]

FRED. BRENNIMANN mentions a recent Swiss patent for a new free escapement, system A. Kaiser, in our above-mentioned excellent Swiss exchange, and says that the simple announcement of the invention of a new escapement will cause the majority of watchmakers to wag their heads, because the number of the inventions of this kind is well nigh as large as the number of their failures.

There are only three, or, at best, four, escapements which have survived the general wreck and are employed, to wit: chronometer, anchor, cylinder and duplex. The writer of these lines himself received the details concerning the new invention with extreme caution, but he has satisfied himself, both theoretically and practically, that he had this time found an escapement which has a future before it.

It might with advantage replace both the cylinder and anchor escapements, especially in the case of watches made by factory work.

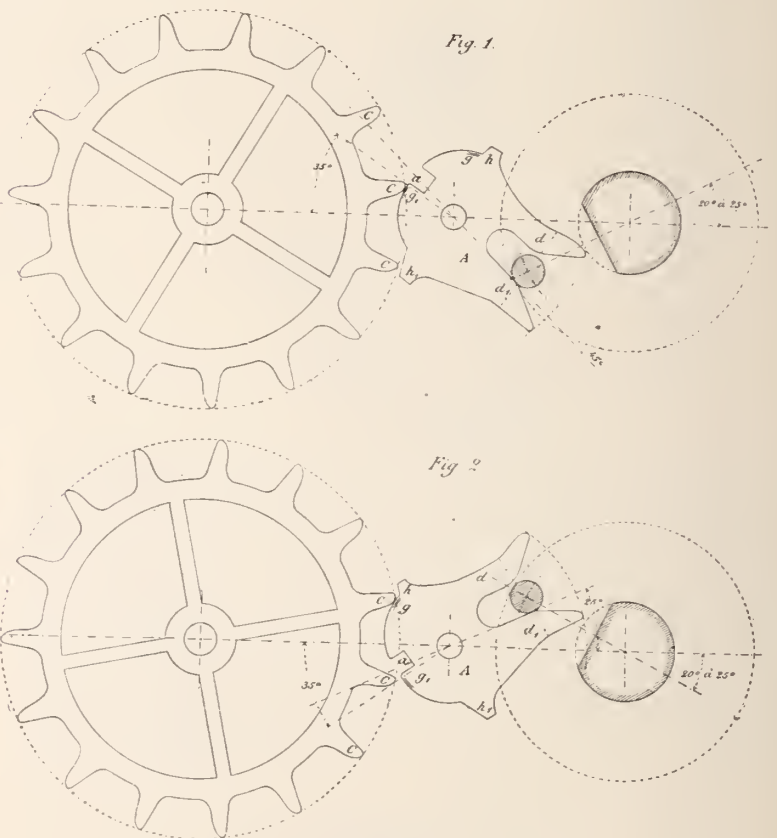

It is distinguished by its great simplicity and its facility of execution, and at the same time all the difficulties of uprighting and repairing are avoided. Figs. 1 and 2 represent the escapement at repose upon the concentric repose of exit and entrance. The principal part is the intermediate piece *A*, in the shape of a lyre, which transmits to the balance for its two vibrations the motive force imparted by a tooth of the scapewheel. The wheel reposes upon the arcs *g* and *g* during the free motion of the balance.

This piece *A* is furnished with: 1. A notch or groove, *a*, into which each tooth of the scape wheel may drop; 2, of two concentric repose surfaces, *g* and *g*, of different radii, contrived in such a manner as to produce a drop of the wheel during the passage from the position shown in fig. 1 to that in fig. 2; 3, of the sliding surface *g* *a*, sufficiently eccentric or inclined, so that the tooth may fall upon the repose *g*, without entering into the notch which prevents the ordinary recoil of the escapement; 4, of the arms *d* and *d*, forming the prongs of the fork; 5, of the stops *h* and *h*, limiting the motion of the piece *A*. It is obvious that the pin and the small roller (*plateau*) perform the same functions as in the anchor escapement.

In the position of equilibrium of the balance, a tooth *C* lies in the

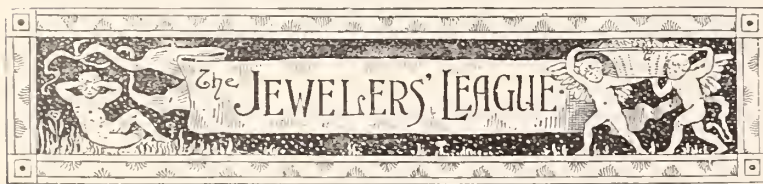

President, HENRY HAYES.....Of The Brooklyn Watch Case Co.
 First Vice-President, JAMES P. SNOW.....Of G. & S. Owen & Co.
 Second Vice-President, ROBERT A. JOHNSON.....Of Celluloid Enamel Co.
 Third Vice-President, JOSEPH B. BOWDEN.....Of J. B. Bowden & Co.
 Fourth Vice-President, CHARLES G. LEWIS.....Of Randel, Baremore & Billings.
 Secretary and Treasurer, WILLIAM L. SEXTON.....Of Sexton Bros. & Washburn.

EXECUTIVE COMMITTEE.

GEO. H. HOUGHTON.....With Gorham Mfg. Co.
 WM. H. JENKS.....With Tiffany & Co.
 A. A. JEANNOT.....Of Jeannot & Shiebler.
 GEORGE R. HOWE.....Of Carter, Sloan & Co.
 WM. BARDEL.....Of Heller & Bardel.
 J. R. GREASON.....Of J. R. Greason & Co.

At the regular monthly meeting of the Executive Committee, held on Friday, October 4th, there were present Messrs. Howe, Lewis, Bardel, Greason, Jeannot and Sexton.

Three requests for change of beneficiary were received and granted, one application was referred, and the following applicants were admitted to membership: W. P. Blake, Hot Springs, Ark., proposed by H. C. Mackinney and Albert J. Smith; Adolph Englesman, New York City, proposed by Silas Stuart and S. G. Lane; B. F. McKinley, New York City, proposed by Ralph M. Hyde and W. H. Jenks; Wm. C. Parks, Brooklyn, N. Y., proposed by G. W. Parks and S. G. Lane; Martin Shafer, Brooklyn, N. Y., proposed by I. A. Lewis and S. G. Lane; L. F. Wachter, New York City, proposed by C. H. Morrison and H. F. Baker; Carl Wahler, Philadelphia, Pa., proposed by H. C. Rowbotham and P. Muhr; John W. Wentworth, E. Orange, N. J., proposed by C. E. Mather and S. G. Lane.

The next meeting of the Executive Committee will be held on Friday, November 1st, 1889.

interior of the notch *a* ; it can press against one of the sides of the notch, in order to set the balance in motion after the first winding with the key. The piece *A* being nearly circular, it is easily equi-poised, which is not always the case with the anchor fork with counterpoise. During the return from the position 1 into the position 2, the scapewheel advances 3°, and since the radius of repose *g* is smaller than that of the surface *g a*, at the point *a*, a drop of about 2° is produced at the moment when the notch *a* passes before the tooth. The recoil of the wheel is prevented in this manner.

Besides this, it is necessary to mention that at the moment of the passage of the notch *a* before one of the teeth *C*, the intermediate piece *A*, as well as the balance, possesses its greatest velocity, while the scapewheel is barely commencing to move. This difference of velocity is very favorable to the passage of the tooth, without either jar or recoil.

As in the chronometer escapement, the impulsion is produced by direct depthing in the two vibrations. This method of impulsion permits of the greatest restriction of the friction of sliding, which is not the case either with the cylinder or the anchor. Calculation shows, for instance, that the power absorbed by the friction during the lifting is seven-fold greater in the anchor escapement than in that of Mr. Kaiser.

By attaching due weight to all the factors, it may be justly said that the new escapement, more than the anchor and cylinder, permits the utilization of the force developed at the periphery of the scapewheel. The watches and clocks constructed according to this system testify by their superior rate that the theoretical provisions are just and complied with.

Since writing the above, THE CIRCULAR has received a very recent number of *La Fédération Horlogère*, Geneva, Switzerland, which contains a lengthy article in praise of the above escapement. It says in effect that the late patent law has caused so large a number of "inventions" to appear before the public, the real merits of which, however, are *nil*, that one really becomes sceptical as to the merits of the entire lot. When glancing through the list of patents recorded, bearing on the horological industry, one is struck with the great number of chronographs, counters, minutes, seconds, etc., timers which, for the greater part, are nothing but modifications of more or less ingenious arrangements of systems employed before the promulgation of the patent law.

Especially in the matter of escapements, the spirit of innovation has been most prolific, and the number of inventions, improvements and modifications in escapements which, as every horologer knows, are the soul of the watch—border on the marvelous; cylinder, anchor, spring detent, pivoted detent (bascule), tourbillon, duplex and others, vary in wild confusion, and when the watchmaker hears of a *new* escapement, he smiles derisively.

For once, however, his scepticism is at fault, because a new system of escapement has been devised by a Swiss, Alexander Kaiser, civil engineer, at Fribourg, Switzerland, which may with justice claim the employment of the above adjective. It is very simple, and has the merit that the pieces composing it may be stamped out by proper machinery in the factory.

The editor then copies above (Mr. Bröennimann's) article, and says in conclusion, that the encomiums, emanating from a gentleman whose profound knowledge on matters pertaining to horology, will not be gainsaid by any one [Mr. Bröennimann is the ex-director of the horological school of Bienne, Switzerland.—Ed.], and gives great weight in favor of the new escapement. A model was submitted to the International Congress of chronometry, recently sitting in Paris, which, recognizing its eminent merits, appointed a committee composed of Messrs. Rodanet, Paul Garnier, Brown, Alexis Favre, Leroy, Antoine Paillard, and Callier. The report of this committee is very favorable, and in ardent expressions thanks the inventor for having contributed toward the progressive development of the horological art.

To judge from the above, our authority says, we are well entitled to assert that this is really a new escapement, which may have a future before it. The closing sentences deplore the fact that Swiss inventors have too often been compelled to go to foreign countries and sell their patents, and that the paper hopes that for once a sufficient number of enterprising Swiss watch manufacturers will be found to keep the patent and manufacture the watch at home.

A New Safety Watch Bow.

THE illustrations show separate and sectional views of a new watch bow fastener, just patented in America by Henry East and Fred L. Turner, of Birmingham, England.

It will be seen that the bow has integral grooved heads, the necks of which are made to engage with the pendant provided with longitu-

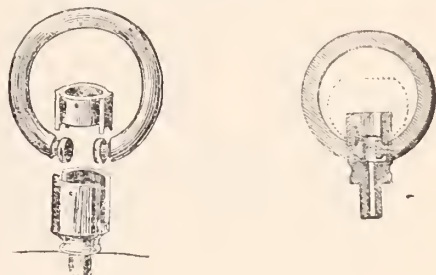

dinal slots, ending in circular recesses. There is also a filling up piece which has a dovetailed projection at each side intended to work into the pendant, and curved at the bottom to fit neatly on the bow. It is only necessary to push the bow down the slots, put in the filling up piece, and secure the latter to the pendant by a screw. A strong fastening is the result.

Dr. Wells' Patent Eyeglass.

THE new eyeglasses illustrated below, as will readily be seen upon examination, contain a radical change from the usual products of our optical goods factories.

The purpose of the inventor, Dr. W. S. Wells, of New York, is to perfect an arrangement whereby the glasses are firmly supported in proper position upon the nose without consequent pain from the pressure upon the tear-duct and the accompanying artery, vein and nerve. In figure 1, *ee* denotes pads that securely, though softly, clasp the fleshy portion above the nose, not touching the bony por-

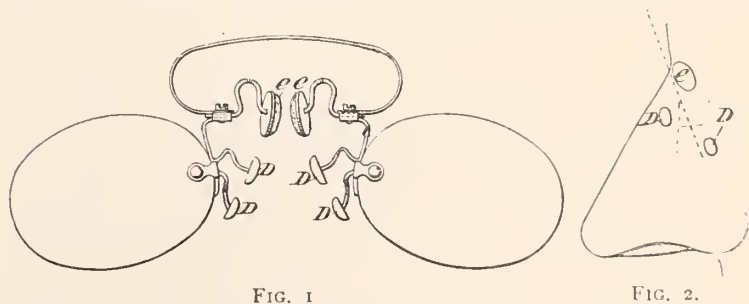

FIG. 1

FIG. 2.

tion at all. *D D* are other pads that arch over the sensitive vessels above mentioned, grasp the cartilaginous portion of the nose and tend to keep the glasses steady. Fig. 2 is a diagrammatic view showing the position of the eyeglasses and the arrangement of the pads.

The inventor claims that, when once fitted the glasses cannot fall off when the wearer sneezes, and cannot tip forward; and the pads or clasp portions touching but non-sensitive parts, they can be worn for hours without discomfort. He wears a pair of these glasses himself, and the device appears thoroughly practical.



Proceedings of the Watchmakers' and Jewelers' Union.

Second Meeting.—Reported by the Secretary.

[NOTICE.—Communications should be received here by the 10th day of the month, in order to be discussed at our meeting for that month and inserted in the next number of THE CIRCULAR. Address them to "Secretary of the W. & J. U., care of THE JEWELERS' CIRCULAR, 189 Broadway, New York." For further information for correspondents, see our Proceedings in THE CIRCULAR for October.]

HISTORY OF WATCH MAKING.—DEMAGNETIZING WATCHES.

Secretary of W. & J. U.

In reading over your Complete History of Watch and Clock Making, I see you give Mr. Howe's name, who worked for Shreve, Crump & Low, but I did not see Addison Bracton's name, who did business and died in Lowell, Mass. Mr. Howe was his first apprentice and I his last one. He made complete watches, case, movement and all. I have one of his movements now; also his wheel cutting and rounding up tool, which was smuggled over in 1812. His uncle paid \$500 in gold for them and made him a present of them. There is also a Mr. Metcalf, who lived in Hoxkinton, Mass., who made watches in 1812.

I see that you succeed the former Horological Club of New York. The last communication I had with the Club was on demagnetizing watches. The Club all laughed at me and called me a "crank." What do you think about it now? I knew what I was talking about, as I demagnetized watches forty years ago. I may be a little egotistical, but I claim to be the first person who ever did it.

Yours, etc.,

CHAS. A. TRIPP.

Brattleboro, Vermont.

Mr. OLD TIMER was glad to receive Mr. Tripp's items about our pioneer watch manufacturers. Some of those men were real geniuses and their memories should be preserved. He hoped all others who knew of omissions or inaccuracies would take the trouble to write down all the facts they can supply, and send them either to us or to Chas. S. Crossman, 23 Maiden Lane. No one could appreciate the immense amount of labor and research required for such a history except those who have had experience, and it would be more than strange if a few omissions did not occur. But if those who have the information will come forward with it, the history, when published, will be made as nearly correct as it is possible for anything to be.

With regard to the former Horological Club, the speaker said he had also been a member of that body, but he had no recollection of Mr. Tripp ever being called a "crank" for suggesting the demagnetizing of watches. If Mr. Tripp could give an idea of the date he would look over the Proceedings and try to find it. But he was sure that the Club had always been very liberal and encouraged new ideas. As one instance, the Club was almost the first to publicly endorse Mr. Giles' anti-magnetic shields and to declare that they were based on scientific principles and had real practical value. And that was at a time when most watchmakers laughed at the idea and thought it a sort of humbug, just as Mr. Tripp says his idea of demagnetizing watches was laughed at. The speaker was confident that it must have been some other body which did that.

He would put on record Mr. Tripp's claim to be the first man to demagnetize watches. If anybody can beat it let us hear from him. And it would be very interesting if Mr. Tripp and others would describe the first methods and apparatus employed, so that we could compare them with those of the present day, and see how much we have improved on them, if any.

Returning to the subject of the Horological Club, the speaker explained that the similarity of the present Watchmakers' and Jewelers' Union to it arose from the fact that we answered inquiries as the Club formerly did, and this was done by the request of the editor

of THE JEWELERS' CIRCULAR. But the scope of the Union is very much broader than that of the Club had been in its membership and in the field of work which it proposes to occupy, as any one could see by reading the Proceedings of our first meetings. Many who had been members of the Club are also members of the Union, for the simple reason that it is the most enterprising portion of the trade which always joins such societies, and they had therefore joined both of these. The speaker had chosen a new name, but most of them preferred to retain the same *pseudonyms* as in the Club.

We hope to be "nearer to the people" than the Club was, and want the trade to write to us about anything and everything that interests them. No matter whether your ideas are orthodox or heterodox, commonsensical or fantastical, practical or theoretical, send them in. Give us something new to stir up the trade, to think over or to quarrel over—anything to stir things up. Don't be afraid of being called a "crank." That is a far more honorable title nowadays than "old foggy" or "slow coach." The "cranks" are the salt of the earth. They are always ahead of us, feeling out the way for us. Even when they are wrong they make us think and do us good. Send in your new ideas, those best ones which you have never ventured to make public lest you should be pooh-poohed and laughed at. If they have merit we will stand by you, even if it takes the hair off. We are not afraid of an idea because it is different from the popular beliefs—we like it on that very account. Now is your chance to launch those brilliant conceptions of yours, supported by friends and sponsors.

Correspondents who wish their names published can sign their communications; if they prefer, they can sign initials, or some assumed name, giving the real one in their letter as a "guarantee of good faith."

WHO SHOULD PAY FOR TOOLS USED UP, THE WATCHMAKER OR THE EMPLOYER?

Secretary of the W. & J. U.:

For the benefit of members of the craft I would ask if a jeweler employing a watchmaker furnishing his own tools, if the employer is expected to supply the place of small perishable tools, such as files, etc., used up by the watchmaker whilst working for his employer, or is the employed expected to get such things as they are needed? Please answer and oblige,

Yours truly,

E. HERTZBERG.

San Antonio, Texas.

Mr. UHRMACHER replied that the rule is for the watchmaker to furnish everything except oil, benzine, alcohol, pegwood and pith. He goes into a shop, finds a bench ready for him, and on that bench he arranges his own tools in his own way, so that he can work in the manner he has been accustomed to, and presumably to the best advantage. If he is a poor workman, his kit will be poor and in poor condition, and when his work proves unsatisfactory he cannot excuse it by saying that he had to use tools he was not used to, or that the shop had not proper facilities or anything of the kind, but will have to bear the blame himself. If he is careless and breaks tools he has to pay for them himself, which will teach him to be more careful.

Mr. OLD TIMER said that when he was a boy and learned the trade it was not so. The watchmaker had his kit and used most of them, but those which were most liable to wear or break, such as brushes, files, fine broaches and drills, were either furnished by the employer or were made good by him when broken. When a drill broke the watchmaker set to work to make another on his employer's time. Wheel cutting and rounding up tools, Universal lathe, uprighting tool and all of the most costly attachments were in the shop tool case. When any of them were broken or injured by the watchmaker he was expected to pay for them, but there was no rule to govern the case. Some workmen would never pay for anything. Of course, there would be a big quarrel over it, but if he was a valuable man he would be kept—if not, he would have to get out.

Mr. BENCHMAN said he was so unfortunate as to belong to the class under discussion. It was very easy for employers to say that

the watchmaker must do so and so. Everything is laid on him. If anything breaks, or burns, or gets lost, strayed or stolen, take it out of his wages. If the boss drops a watch when giving it to the customer and breaks something, he swears that that condemned watchmaker doesn't know his business, and he will get another man right away. He will set a repeater backwards, or turn the regulator with his toothpick and let it slip off against the balance and break the pivot off, or he will move the hands of a calendar around with a pair of pliers, and then blame it all on the watchmaker. He will sneak in to do a little job of his own with "those nice tools on the bench," and break some of them; then when the watchmaker comes in he will swear nobody has been near the bench. All the blunders of all the blunderheads in the store are charged to him.

As for himself, Mr. BENCHMAN said, he worked by the piece, and therefore was not complaining of his personal grievances, but was saying a good word for the great body of the watchmakers throughout the country. He thought they were imposed upon in the matter of wages. \$15 a week is considered very liberal, \$18 and \$20 is outrageous, and \$25 is a swindle. Employers want to get the best class of mechanical talent for less wages than are paid to a drunken plug machinist in a machine shop, and then make him stand the breakage and wear of tools out of his scanty pay. In a machine shop the shop furnishes the tools, and the workman does not pay for breakages unless clearly due to his gross carelessness or incompetence, and so it should be in our trade.

Mr. HOROLOGER said there was reason in all things. Wages were not high, but he would ask whether the ordinary country watchmaker could afford to pay any more? He thought that in most shops there was little or no profit on the watchmaker, any way, and very often there was a loss; \$10, \$12 or \$15, in a country town, is not bad. If the man is an extra good workman and worth more, he need not stay in a country town, but can go where wages are higher, because employers can afford them.

As to breakages, he was inclined to think that it was the only safe way, to have the watchmaker furnish his own tools and use them at his own risk. If they belonged to the shop the men would be sure to be careless with them, and the whole lot would be practically worthless in a very short time. Besides that, how could an employer keep watch of the multitude of little things to tell whether they are being properly used, or broken, or if old, worn out things were being put in their places? Half of them might be gone before the boss could notice anything wrong.

If there is a great hardship in any special case of breakage or wear a reasonable employer will always do what is fair. But there is not much loss when tools are carefully used. And again, after he has found a watchmaker careful, competent and conscientious about such things, he will be willing to make special arrangements with him, if it seems to be called for and just. Although the rule was as stated by Mr. UHRMACHER, exceptions are often made by agreement between the watchmaker and the employer. There may be occasional hardship in the usual rule, but he did not think there was any injustice in it.

JEWELERS' ADVERTISEMENTS.

Secretary of the W. & J. U.:

We have put up sign boards on all leading roads out of town. In other words, they are mile posts, 1, 2 and 3 miles out. We find this an extra good advertisement and would advise other jewelers to try it.

J. W. SCOTT'S SONS.

Caliz, Ohio.

Considerable discussion ensued on this subject, and Messrs. Scott's idea was generally thought to be a good one. The sketch sent was not good enough for copying, but it read, "1 mile to J. W. Scott's Sons, jewelers," on the sides of the post. One member advocated the painting of similar signs on the fences, barns, etc., but others thought that would be rather too vulgar for jewelers. All agreed that the great point was to "keep your name before the people," and the only dispute was over the way of doing it. One was as punc-

tilious as a doctor about advertising, which others characterized as silly.

Newspaper advertising was considered the best, but what should be done when there were so many papers that one could not afford to advertise in them all? One proposed a bogus robbery or accident of some kind to draw in the reporters, give them plenty of beer, then show them the paste diamonds with all the candles and lights burning around them, and add three cyphers to the prices to impress them with the immensity of the stock and get a fat notice in the papers. But the older members sat down very heavily on that suggestion, and insisted that there should never be any dissimulation or clap-trap about a jeweler's advertisements, conversation or business. He should be a solid and square man, doing a square business, in a square way, and then he should insist upon being believed and trusted in everything he said and did. Confidence, they said, was the life and soul of a jeweler's business; unless he merits confidence and secures it he cannot be successful. Others did not believe a man should be too awful particular about the cut of his breeches if he only "got there." That was the main point. And at last, failing to agree, they agreed to disagree.

At this point the Chairman said that he would have to apologize to the gentleman for an oversight. The next letter on the programme was on the same subject as the one just read (but was received very late), and should have been read and discussed with that. He hoped that they would excuse his inexperience for that time, and the letter was then read.

WHAT MAKES THESE WATCHES STOP?

Secretary of W & J. U.:

I wish to ask your advice in regard to some watches that are troubling me. I have had nearly 14 years' experience at watch repairing, but do not claim to know all about it. I am troubled as I never have been before by watches stopping. A watch is brought in to be cleaned, I look it over carefully, clean it, polish the pivots, if necessary and do every thing that my knowledge and experience tell me to do to put the watch in the best possible shape. The watch starts off nicely, runs well for a few days or weeks, when the motion slows down and it stops. I go through the same process with the same results. I have thought it was defective oil, but I buy W. F. Nye's oil, which I suppose to be the best. I have tried running a few days without oil, and have tried oiling very lightly, but still these same watches come back after running a short time. I learned my trade under good circumstances in the city, and I thought I could repair watches, but these watches puzzle me. I do not know what it can be unless it is magnetism. I have tested for it according to Excelsior, and find traces of it in some of them. Please help me out of my trouble if possible, and tell me what to do. Yours truly,

Fillmore, N. Y.

W. S. M.

Mr. EXAMINER responded that it was rather risky to tell what ails a watch without seeing it, or even knowing what kind of a watch it is. It is hard enough sometimes, to find out when you have the critter under the glass. But he thought the trouble could not be magnetism, because a magnetized watch would stop at the shop, as well as a few days later; and again if magnetized when brought back, cleaning and fresh oil would not cure it. It was not likely to be due to poor oil, because that would effect all of his watches in the same way, whereas, we understand him to say that only a certain few act in that way.

He was disposed to think that there was some part of the movement which got loose or moved after a while, and caused the trouble. In some watches, the dial will work loose and crowd the hands or dial wheels; the movement may work loose in the case by carrying, and letting something rub against it. Very often a cap over a wheel will get pulled to one side and let the wheel work too deeply into the next pinion. That is often the case with the third wheel cock, and others, also the balance cock, and that over the lever. This arises from the steady pins not fitting their holes, so that the cock is only held in position by the screw forcing it against the plate. He thought that Mr. W. S. M. would probably find something of that sort, on examination. If any of our readers think they know what it is, let us hear from them.

BOOK MARKS AS ADVERTISEMENTS FOR JEWELERS.

Secretary of the W. & J. U.:

The writer saw the account of the formation of the above Union in the October

CIRCULAR. It will, no doubt, prove to be a great benefit to the craft.

A part of my duties is to attend to our advertising, which requires a great deal of thinking and some ingenuity to originate advertising for distribution that is tasty, attractive, inexpensive, and something that people will use or keep, for a time, at least.

I enclose a "book mark" of my own design that has proven a splendid medium. Our first lot went in a very short time; we mailed some and placed the remainder in our cases, when they soon disappeared by being carried away by grown people and not children. Now, our second lot, larger than the first, is exhausted, and we still have requests for them. You probably know best how to describe or illustrate these intelligibly.

I send this in the hope that it may be a help to other advertisers, and that they may be induced to send a description of any successful scheme they may have had in this line. I trust you will believe this worthy of notice.

A CORRESPONDENT.

The samples were handed around for inspection. As shown by the accompanying illustration, the device consists of a narrow strip of tinted card board, folded over and having printed on each side a card describing special goods handled by the firm. In the fold was secured a long silken cord ending in a neat tassel, with a gilt ornament. Both sides had "Book Mark" printed at the top, so that no one could fail to understand what it was for.

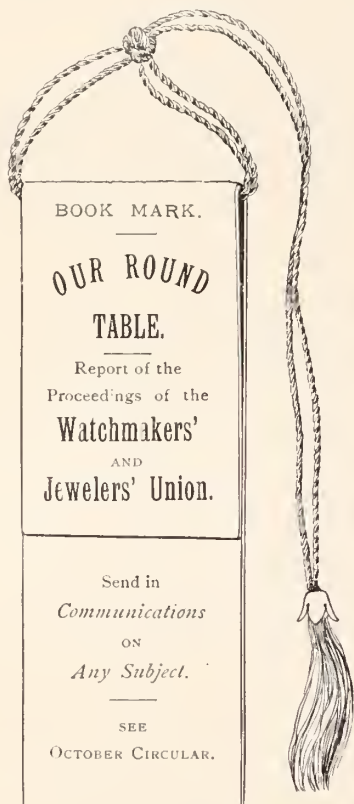

All agreed that it was very neat and tasty, entirely suitable for a jeweler to use, very likely to be kept a long time by the recipient, if he or she was a person of literary tastes, and the number of times those cards would be seen and read was beyond calculation.

Messrs. Scott and "Correspondent" have told us of two good things. Let us hear from the rest of you who have good ideas in the advertising line. We all have goods to sell, and want to know how to interest the public and bring them to our stores. If we put our heads together we ought to find out plenty of things worth knowing. Tell us how *you* do it.

"CLEANING ELECTRICITY OUT OF WATCHES:" SECOND LETTER.

Secretary of the W & J. U.:

You fellows seemed to have a good deal of sport over my letter at your meeting last month, but it only showed your ignorance. Mr. ELECTRODE talked about my having cobwebs on the brain, but if he knew anything about such things he would know that a living person cannot have cobwebs on his brain. There is no way for them to get there. Such talk shows that he doesn't know what he is talking about. Neither does he know anything about electricity.

I say watches do get charged with electricity, and I can prove it. And what is more, I can cure it too. Getting the electricity out of a watch is cleaning it out, aint it? Well, then, what is he blowing about, any how? I said I could clean the electricity out of a watch, and so I can, I don't care how many ignoramuses deny it. If any of your readers don't believe it, let them buy my receipt and try it, and they will be satisfied. I defy any man to try it, and then say it don't work

just as I claim. I hope you will print my name this time, so those who want to try it will know where to write.

J. W. P.

Mr. HAIRSPRING-TWISTER sprung to his feet, full of virtuous indignation, or something else, and exclaimed:

Mr. Chairman: This is my first appearance before this honorable body. I have belonged to all the trade societies which have been organized in this city, and am glad to belong to this one. But I am sorry to see it opposing the gentleman whose letter was just read. That letter, sir, is the solid truth, and no mistake. I am happy to make my maiden speech here in defense of injured innocence, and in behalf of right and justice. And that gentleman truly says, it is impossible for cobwebs to get into a person's brain. And what has cobwebs got to do with electricity, any way? That kind of talk is a mere evasion of the question, sir, a mere subterfuge, unworthy of the dignity and high moral standing of this honorable body.

Now, sir, what are the facts in this case? There is electricity everywhere. We all know that. It floats on the circumambient atmosphere, and distils out from the delicious and deliterious breezes, and insinuates itself in all the crevices of nature.

Now if electricity is everywhere, like that, won't it get into a watch, if it has a chance? Of course it will. What is there to prevent it, I would like to know? As that gentleman truly remarked, watches do get full of electricity, and I know it, for I have seen it myself."

Mr. ELECTRODE: "Will the honorable member allow me to ask him a question?"

Mr. HAIRSPRING-TWISTER: "Yes, if it is pertinent to the subject."

Mr. ELECTRODE: "How did the watch look, when it was full of electricity?"

Mr. HAIRSPRING-TWISTER: "Look? Why it looked just as it always did, of course. You don't think the electricity bent it out of shape, do you?"

Mr. ELECTRODE: "Well, if it looked just as it always did, how did you know it was full of electricity?"

Mr. HAIRSPRING-TWISTER: "I could feel it."

Mr. ELECTRODE: "How did it feel?"

Mr. HAIRSPRING-TWISTER: "Well, really! If the honorable member don't know how electricity feels, he shouldn't set himself up as a teacher."

Mr. ELECTRODE: "I am unlike some people, as I do not pretend to know everything, and am always ready to learn. If Mr. HAIRSPRING-TWISTER knows how a watch feels when it is full of electricity, I would be glad to be informed."

Mr. HAIRSPRING-TWISTER: "I am not teaching electricity, just now. I am standing up for the gentleman with the receipt, to protest against the unjust treatment which he has been subject to, without a shadow of reason, or justice, sir, from this honorable body, which should be a help for the inquirer.

After order had been restored the members thinking they had had enough for one night, voted to adjourn.

(To be Continued.)

LIGHT ON THE BENCH.—For night work the so much abused light balls are decidedly to be recommended to the watchmaker; they collect and concentrate all the rays of light with great intensity upon a certain point and if a shade of pasteboard is placed over them, they shade the eye completely, which is not irritated by any ray of light falling in any other direction. Besides this, all the heat accompanying the light is absorbed, and only the latter is transmitted through the water. When purchasing these globes, choose them of a good size. It is also necessary to have the water crystal clear, which is easily done by dropping a few drops of chemically pure nitric acid into it; the globes are then well corked and set aside for some time, to classify. The clearness of the water increases with its age.

Copyrighted 1888 by Charles A. Bucklin.

Mechanical Ocular Defects.

Their Nature, Cause, Correction and Relations to Functional Nervous Diseases.

EDITED BY C. A. BUCKLIN, A. M., M. D., NEW YORK.

[The aim of the author is to produce a clear and thoroughly practical course of instruction on the subject of "mechanical ocular defects," which is entirely void of useless technicalities and within the easy comprehension of every thinking student without his having had any previous technical or mathematical education.]

ACCOMMODATION.

THE mechanism of accommodation, although simple, has been a field on which the warmest discussions between thinking men have taken place, and I doubt to-day if all dissension from Helmholtz's theory of accommodation has ceased. His theory however is the only one which can stand for a moment the scrutiny of unbiased investigation. His explanation is essentially as follows: The ciliary muscle is the positive element in producing accommodation. Its contraction loosens the Zonula of Zinn and by relaxing the suspensory ligament removes the pressure of the anterior and posterior capsule on the poles of the lens. This allows the lens from its own elasticity to become more convex, thus adjusting the dioptric apparatus for the divergent rays which come from near objects. The pupil contracts owing to the close connection between the common nerve supply, but the ciliary process does not come in contact with the edges of the lens, the change in the form of which is never produced by the application of force to its edges, as is popularly supposed. The relaxation of the ciliary muscles allows the elastic fibres of the ciliary muscle to again produce an elastic traction on the Zonula of Zinn. Thus the suspensory ligament, by the now not counteracted elastic force applied to it, causes the capsule to tighten and the lens returns to its less convex condition. During accommodation the increase in the convexity of the lens is confined almost entirely to its anterior or front surface. At this point a great amount of time is devoted to the consideration of the positive and negative range of relative accommodation, also to the binocular as compared with the monocular range of accommodation. The positive part of the range of relative accommodation simply means how much one can accommodate with a given point of fixation. The negative part of the range of relative accommodation represents how much one can relax with this given point of fixation. The strongest concave lenses through which one can still see at the given point represent the positive part of the relative range of accommodation and the strongest convex lenses through which one can see distinctly at the given point of fixation represent the negative part of the relative range of accommodation. The practical conclusion is that at any point of convergence at which both eyes are required to see continually there must be a reserve of accommodation or continued work is impossible. In other words, a set of muscles cannot work *continuously* if the imposed task requires their utmost capabilities.

The fact that one can accommodate much more when relieved of the necessities of binocular fixation, although self-evident, is the underlying difficulty which produces so much confusion in clearly understanding many of the phenomena occurring in and as a result of hyperopia, *squint* and *asthenopia*.

DISEASES OF ACCOMMODATION.

We have *presbyopia*, *pareisis*, *paralysis* and *spasm* of the accommodation.

The power of accommodation, other things being equal, declines in a most regular way as years advance. Starting with the tenth year, Landolt gives the following table representing the average decrease in the power of focal adjustment:

Years.	Range of Accommodation.	Years.	Range of Accommodation.
10	14 D.	65	0 75 D.
15	12 D.	70	0 25 D.
20	10 D.	75	0
25	8.5 D.		
30	7 D.		
35	5.5 D.		
40	4.5 D.		
45	3.5 D.		
50	2.5 D.		
55	1.75 D.		
60	1 D.		

From the above table it is seen that the power of accommodation decreases rapidly as age advances. It is surprising that this one function which is of such great importance should commence its decline at the tenth year of life and continue to gradually fail while our muscular system is in a state of progressive development. We cannot look to the failure of the ciliary muscle for the cause of this progressive failure in the accommodation. We must look to the only remaining element concerned in the accommodative mechanism, namely, the elasticity of the lens which, if the above table is true, is shown to gradually decrease from the tenth year. As the near point of distinct vision gradually recedes a time finally comes when, although most laborious efforts are made to produce accommodation, it becomes *fatiguing* or *impossible* to read or do fine work at the distance required. The first complaints are of the poor-ness of the print at night and the dimness of the light. The eyelids smart and the eyes become irritable. The work is held at the greatest practical distance. The average working distance being twelve inches, these symptoms are likely to appear when the near point has been removed to a distance so near twelve inches that nearly the entire energy of the ciliary muscle is called into action to accommodate for the working distance. This removal of the near point becomes sufficiently great from the *fortieth* to the *forty-fifth* year of life to be very annoying. A glass for a given age cannot be given. The individual requires convex lenses when he is unable from the above causes to do required tasks at the distance at which his *habits*, *acuteness of vision*, and the *nature of the task* require him to work.

The glasses required will be the *weakest* convex lenses which enable the individual to do required tasks at a required distance with comfort and without decided or apparent magnification.

Donders has given a table showing the lenses required at a given age, where the decline of accommodation is due to advancing age *alone*. Disease, errors of refraction and the early use of unnecessarily strong convex lenses, may make wide differences in the lenses required at the same age in different individuals. The table, however, shows the *usual* corrections for presbyopia at a given age, and when hyperopia is combined with presbyopia this table is a convenient check which demonstrates that although the lenses worn are very strong owing to the co-existing hyperopia, still the presbyopia for the given age has not been over-corrected. The degree of hyperopia being subtracted from the glass used in reading, the remainder will be the amount of presbyopia.

DONDERS' TABLE.

Glasses required in simple presbyopia which is not complicated by any error of refraction or diseased condition of the accommodation:

Age, 48, Convex 60	Age, 62, Convex 14
" 50, " 40	" 70, " 10
" 55, " 30	" 75, " 9
" 58, " 22	" 80, " 7
" 60, " 18	

In ordering the glasses for a nervous person, who for the first time seeks advice, owing to annoyances incident to presbyopia, much difficulty is frequently experienced in giving the individual

satisfactory lenses, for the following reasons: *First*—All glasses reduce the amount of illumination coming from the observed object. *Second*—There is always a reflection from lenses which is annoying to the inexperienced person who is entirely ignorant of managing his lenses so as to reduce the reflection to the least possible amount. Individuals who are accustomed to wearing lenses unconsciously avoid allowing the surfaces of their lenses to remain for any time at such an angle to the direction of the main source of light that the reflection falls in the pupils of the eye. The reduced degree of reflection thus obtained they become accustomed to, and experience no noticeable annoyance from it. *Third*—The lenses introduced early for the correction of presbyopia produce a disturbance in the natural relations existing between fixation and accommodation. This trouble may be partially compensated for by using the prismatic as well as magnifying effect of the convex lens. Thus the lens making the habitual degree of accommodation less, also makes the natural corresponding degree of convergence less. To compensate for this artificially produced defect the centers of the lenses are set inside of the lines of vision at the reading distance. This has the same effect that two weak prisms would produce with the bases in. This decreases the work necessary for the internal recti muscles in producing the necessary degree of divergence. Thus the disturbance produced in the relations between fixation and accommodation have been partially compensated for. *Fourth*—Inexperienced individuals are further annoyed in their first attempts to wear convex lenses by their ignorance of the fact that the centers of each lens must be placed at a given height. When the vertical muscles are normal the centers of the lenses must be on an absolutely horizontal line. The deviation of $\frac{1}{8}$ of an inch from this position is annoying. When there exists a faulty vertical muscle then a certain tilt to the frames is the only position in which the lenses can be used. *Fifth*—The failure to place the surface of convex lenses at right-angles to the line of vision creates an artificial astigmatism which, when added to a small degree of natural astigmatism in a corresponding meridian, becomes annoying. The glance being downward at the book the tilt of the lenses must be sufficiently forward to bring the surfaces at right angles to the line of vision in this class of cases. Other persons have a mild degree of natural astigmatism which they correct by looking obliquely through convex lenses.

When the individual as the results of his own experience learns to make such improvements in the correction of his defect as can be made by the position of the lenses and the annoyances incidental to the presbyopia far outweigh the annoyances incidental to the correction of the defect; then the individual will cling to his glasses with satisfaction and be contented. The correction which can be gained through the proper adjustment of the position of lenses has been greatly neglected. This part of the correction having been almost entirely supplied by the experiments of the persons wearing the lenses.

Information regarding the School of Optics will be furnished upon application.

Manufactures in Japanese Prisons.

A VISITOR to a Japanese prison in Tokio thus recounts, in the *Pottery Gazette* (London), a portion of his experiences: We visited a workshop where *jinrikishas* were being made, then one where umbrella handles were elaborately carved, then one where every kind of pottery, from the rough, porous bottle and jar to the egg-shell tea cup, was rolling from a dozen potters' wheels, and then came the great surprise. Two days previous I had visited the house of the most famous maker in Japan of the exquisite *cloisonné* ware—the enamel in inlaid metal work upon copper—who rivals in everlasting materials the brush of Turner with his pigments and the pencil of

Alma Tadema with his strips of metal. And I had stood for an hour behind him and his pupils, marveling that the human eye could become so accurate, and the human hand so steady, and the human heart so patient. Yet I give my word that here in the prison at Ishikawa sat not six but sixty men, common thieves and burglars and peace breakers, who knew no more about *cloisonné* before they were sentenced than a Hindoo knows about skates, doing just the same thing—cutting by eye-measurement only the tiny strips of copper to make the outline of a bird's beak, or the shading of his wing, or the circulations of his toe, sticking these upon the rounded surface of the copper vase, filling up the interstices with pigment, coat upon coat, and fixing and filing and polishing it until the finished work was so true, and so delicate and so beautiful that nothing except an occasional greater dignity and breadth of design marked the art of the freeman from that of the convict. Fancy the attempt to teach such a thing at Pentonville or Dartmoor or Sing Sing. When our criminal reaches his prison home in Tokio he is taught to do that at which the limit of his natural faculties is reached. If he can make *cloisonné*, well and good; if not, perhaps he can carve wood or make pottery; if not these, then he can make fans or umbrellas or basket work. If he is not up to any of these, then he can make paper, or set type, or cast brass, or do carpentering, and if his faculties do not permit of his engaging in any of these useful invocations, he descends to the position of a stone breaker, but he can never be an idler as we seem to prefer to have our prisoners.

How to Drill a Staff.

A N INTERROGATOR, in an exchange, desires to be enlightened by some expert how to drill a staff for a new pivot. He has hitherto used the old-fashioned verge lathe, but has recently bought an American lathe, etc. He has not yet been able to drill the hole to a sufficient depth without taking all the temper out of the staff; he uses the American finished pivot drill and has tried every shape of point, etc. An expert returns the following answer:

After removing the table roller and balance spring, take a circular copper wire, about the same size as a large silver watch case bow, except that the ends come together instead of being open, as in the watch bow; spring the ends far enough apart to insert the broken end of the staff between, then heat the copper wire ring in the alcohol lamp flame, holding the ring in a pair of pliers; the ring will communicate the heat to the staff and the temper will be drawn from the part to be drilled without discoloring the balance or the opposite end of the staff. The temper had better be drawn lower than blue; at any rate draw it to a very light blue, or even softer—that part of the staff has no part to perform, and so the temper is of little consequence. The average staff, as it comes from the factory, is not harder than a dark blue shade will indicate. I do not mean to infer that when fitting a new staff the temper of any part of it is of little consequence, because, if the temper is properly drawn it will be even throughout, and if drawn lower than a dark blue it would be too soft, as the pivots could not be turned down comparatively small without bending, and, even if they were, a high polish could not be obtained, and the result would be that after running in the watch for a short time they would show signs of wear and thereby increase the friction. But in pivoting a staff, as was said before, it will do no harm to thoroughly soften that part of the staff where the pivot is to be inserted, always bearing in mind that the heat must not be allowed to reach the balance, or the opposite end of the staff, which is not broken.

After drawing the temper, place the staff in the lathe and smooth off the broken end with anvil stone slip sufficiently to get your center by; strike your center by means of the graver, holding it in your hand. At first you will be almost sure to leave a little conical

"tit" at the center instead of striking the center correctly, so therefore it will be better to practice a few times on a piece of brass wire instead of the staff, and after a few times you will be able to do it at once and well.

The reason why you cannot drill the staff deep enough is because the drill is not properly shaped or is allowed to get dull, and instead of cutting, it burnishes the metal and hardens it, thereby making it difficult for a sharp drill to attack it successfully.

Make your own drills out of sewing needles as follows: Draw the temper thoroughly by holding the needle in the flame of a lamp until it is nearly red hot, then allow it to cool slowly, file it down considerably smaller than the size of the hole you wish to drill and file the end flat, then spread the end by tapping with hammer, using a stake or punch block with the edge rounded off to lay the end of the needle against; when the end is spread sufficiently, so that the drill will not jam in the hole, harden it by heating it in the flame of a tallow candle (the strength of this flame being less than alcohol and therefore less liable to burn the steel by overheating), and cool by shaking it backward and forward rapidly in the air, if a small drill; if of a larger size, by plunging it several times into a piece of beeswax; sharpen by rubbing it on an oilstone slip on two sides only, leaving a small knife-edge at the center instead of a point, which would be the case if sharpened on four sides.

Now, if the staff is softened as directed and the drill made according to above instructions, there will be no difficulty in drilling even deeper than necessary, but you must of course draw the drill occasionally across the slip to renew the edge, which may dull before a sufficient depth is reached, but after you get into the "hang" of it, you can drill a staff in half a minute. The wire for the pivot should be a piece of a needle with temper drawn to a dark blue. Almost any graver that you can buy will cut any staff if sharpened properly, which means a flat face, a sharp edge and point.

How To Make A Swiss Barrel Bridge.

AN ENQUIRER in a foreign exchange desired to be informed how to make and fit a Swiss barrel bridge, and is answered as follows:

Procure a good piece of brass, clear of sand holes, a little thicker and wider than the finished bridge is intended to be, and make it as hard as possible by a careful hammer-hardening. Drill a hole through your brass bar near one end and in the center, taking it crossways, and screw it down to the plate of the watch; then mark through the opposite screw holes in the plate the place where the other screw hole is to be drilled in the bar, then drill holes in the bar for the steady pins, first marking the position through the steady pin holes in the plate, drill the holes the same size as the holes in the plate, and tap them. Turn your steady pins down to the size in the lathe and tap the ends to be screwed into the bar, screw them in leaving room for the thread projecting beyond the bar, and cut the pins the proper length. Now place the bar in the universal head centering from each of the screw holes and turn out the sink to suit the diameter and depth of the screw heads. Now we are ready to cut out the center hole in the bridge for the barrel arbor to fit into. Notice, before cutting the center hole, that the arbor is smooth and well polished, and if rough or "burry," smooth and polish it before fitting.

Get the center for the arbor hole from the hole in the plate and cut out for the insertion of the barrel in the following way: Fasten the plate in the universal head, centering as near as you can by your eye by this large hole in the plate, then proceed to get the exact center by tapping. Leave the jaws of the universal head grasping the plate sufficiently tight to hold it, but not so tight but that it cannot be moved by a slight tap of the hammer, revolve the plate in the lathe and notice which side of the hole is "high," and tap it accordingly

till the hole runs true; then screw the new bridge on and cut out the arbor hole, and also the sink for the ratchet wheels, and then turn out the sink for the small cap that covers the ratchet well and holds it steadily in place, being careful to have the face of this sink just flush with the face of the ratchet wheel, drill the holes to attach the cap to the bridge and lap this to receive the screws; then file the side of the bridge to which the click spring is attached to suit the click spring, and with a fine three-cornered file, file the opening for the pivot of the click spring to engage with the ratchet wheel, drill and tap the hole on the side of the bar for the click spring screw and steady pin hole.

I should have said that immediately after cutting the center hole for the arbor, the sink or underside of the bridge to receive the barrel must be turned out and then the sink for the ratchet wheel. The bridge is now complete with the exception of the finishing touches; smooth off the sharp edges and remove the burr from the screwholes. Smooth the side carefully with a fine water-of-Ayre or blue stone, and it is then ready for scratchbrushing and gilding, which you can have done at any gilder's, if you have not the necessary gilding apparatus yourself.

To Pivot a Staff, etc.

THE watchmaker finds it necessary occasionally to pivot the staff of an American watch. It is not expedient always to draw its temper, and in such a case the following process had better be followed: The drill must be of the best of steel, made strong, so as to stand considerable pressure upon it, not pointed, but rounded ovally on the end, the edge sharp but not thin, as a thin edge dulls quickly nicks easily and is liable to shatter. When drilling, press hard but firmly and straight, work slowly, press the drill against the metal only in one direction while cutting, and have patience. The cutting edge, of course, must be as hard as it can be made. Many workmen use fluids of different kinds to assist the cutting of the drill, but their use cannot be approved, and, in fact, it is questionable whether they do a great amount of good. The latest idea of the kind is to keep the tool wet with petroleum (kerosene oil), in which is dissolved one-half the amount of tenebinthine. Others recommend spirits of turpentine in which a lump of camphor gum is kept, and to roughen the bottom of the hole with dilute nitric acid, first cleansing out the oil, or the turpentine, etc., before putting this on. Many other preparations are occasionally mentioned, but the good workman will be able to do all that is necessary and proper to be done without any such helps. It must be remarked, however, in conclusion, that it is by no means necessary to drill without drawing the temper. Some workmen do it more to boast of it than on account of the job being better for it. Some staffs are soft enough to drill with little trouble, while others are so hard that it would be almost impossible to drill them without drawing the temper. If the temper is drawn to a dark blue, a pivot carefully fitted, and the staff then re-polished equal to new, the job is in every respect as sound and good as if drilled without drawing the temper, and very possibly an extra hard staff will split in driving a pivot into it. In drawing the temper of a staff, the repairer must be careful not to heat other parts, such as the balance, roller table, jewels, balance spring, etc. They are easily damaged, but it is seldom that a staff is injured by drawing temper to a dark blue.

GOLD MINES.—Besides the very lucrative diamond mines, South Africa also possesses extensive gold mines which, of course, are eclipsed by the greater pretensions of the former. *Afrique Minière* reports that during the year 1888 and the first four months of 1889 there was exported of this noble metal to the value of £1,329,383, of which the Cape Colonies exported £730,580 and Natal £598,703.



ON MAINSPRINGS.—The mainspring is a very essential part in a watch, and it is necessary to treat of it at more length than of other parts of less importance. In watches, for instance, like those made in this country, where the spring can be procured already cut to the proper length, sized, and provided on the outer end with a fastening to suit the different grades, re-springing is a job that requires but little skill; but when one has to select and adapt a spring to a watch of foreign make, to be successful, certain rules must be understood. In their manufacture the springs are drawn out at length and rolled up like ribbon, of the various widths and thicknesses, to suit all the different grades and sizes of watches in the market. These ribbons are cut up in pieces of a given length, one end being punched and prepared. They are coiled up in the shape usually found in the market, the outer end being left blank for a watch repairer to cut and fit for the barrel in hand. If it is run to the full length, it is likely to be too long; in such event, if thick, it will be crooked and certain to break in attempting to wind it up. The springs, however, are never too short, but are intended to be adapted in length as well as in width and strength. As an invariable rule in Swiss and English watches, this adaptation devolves upon the repairer, and as before stated requires an unusual degree of skill. Many watches have come to our hands that were but really refitted with mainsprings by workmen of fair reputation, but upon examination it appeared that all the rules governing a correct adaptation had been entirely ignored or overlooked. Breakage, want of winding capacity, too much or too little force, are faults usually to be found in such cases. The watch may in some manner go for a time, and the owner, through ignorance, may conclude his watch is at fault and replace it with a new one, sooner or later to meet with the same fate. This, it may be remarked, adds to the interest of the manufacturer and dealer, proving the old adage: "It is an ill wind that blows nobody good."

CONCERNING THE PENDULUM.—A curious arrangement, involving the use of bi-metallic strips, was patented in 1840 by Dent, and deserves mention. He proposed to communicate the impulse to the pendulum at its center of percussion, and two arms projected from the escapement, placed below the pendulum, on either side of the bob, for this purpose. Two U-shaped compensation strips were attached to the bob, and received the impulse from these arms; on heating, the pendulum lengthened, the strips moved outwards, and were therefore struck with greater rapidity, since the arc of vibration was diminished; thus the loss occasioned by the expansion of the rod was counteracted.

TO FIT NEW BALANCE PINS.—Knock out the old pins and insert Waltham banking studs. If the old banking-pin holes are too far apart, by fitting Waltham banking studs, you can turn the pins around to the proper positions at will. Turn them so that at all points the shake between the fork and pins at the one end and the guard pins and roller at the other will be the same, and reduce the shake as much as possible. When the pins are adjusted to suit the fork and roller, put the movement together and see that the banking pins are sufficiently far apart to allow the scapewheel to escape. Should the wheel escape on one side and not on the other, the pin binding the pallets and fork together will have to be knocked out and the pallets removed sufficiently to allow the scapewheel teeth to escape on the other side. If they require to be moved very slightly, the pallets and fork can be firmly held in a hard vice and the holes broached out in line with each other, or else the hole in the fork must be filled up and a new one drilled.

TO CLEAN A DIAL.—First dissolve one-half ounce of cyanide of potassium in hot water; to this add two ounces of strongest ammo-

nia and one-half ounce of spirits of wine. Dip the dial for a few seconds and immediately immerse in warm water, brushing it lightly; this will soon show a clean dial; then rinse, and dry off in hot box-wood dust. Some use diluted nitric acid for cleaning dials, or hyposulphate of soda will do it if dissolved and mixed with ammonia; but with either of these the painted numbers go with the dirt, so only dials with gold numbers can be done with this process. We could give several recipes for dial cleaning, but the above is as simple and effective as anything we know.

TO PURIFY GOLD.—"While on the subject of purifying," says a correspondent in an exchange, "I will endeavor to explain the method of purifying gold. To one vessel of 14-karat gold add two ounces of silver; place in a crucible and melt, adding a little borax as a flux. So soon as the alloy is thoroughly melted, it is to be poured into a deep vessel of cold water, kept stirred in a circular motion, which will cause it to become granulated (that is, the metal, not the water), or it may be rolled out thin and cut into small strips. Remove the granulated metal from the water, and treat it with one part nitric acid and two parts water, and allow it to operate for about one and one-half hours, slightly heating the mixture, when chemical action diminishes. The gold will fall to the bottom of the vessel in a dark brown powder. Carefully pour off the acid into another vessel, add a little fresh acid to the gold, applying heat as before, in order to be sure that all the copper and silver have been removed from the gold, which may be known by the absence of red fumes in the vessel. Wash the gold well with hot water, adding the washings to the first solution poured off. The gold may now be dissolved with nitro-hydrochloric acid to make a chloride for plating purposes, or it may be dried, mixed with a little potash and melted. The first solution and washings poured off being nitrate of silver and nitrate of copper, may now be treated in the usual manner."

TO POLISH STRAIGHT PIVOTS.—Straight pivots with square shoulders are polished with a steel polisher, slightly curved along the edge, that acts against the shoulder of the pivot. This edge is also dovetailed a little so as to form rather less than a right angle with the bottom of the polisher. The operator will find by experience the amount the polisher requires to be curved. It is rarely that one man can use another's polisher as well as his own; if the edge of the polisher is too much dovetailed, it will produce a wavy shoulder to the pivot. The pivot must be turned nearly to the right size, and the shoulder quite square. During polishing, the end of the pivot must rest on the end of the runner. A piece of paper may be placed underneath the pivot to reflect the light. The light so reflected must be divided equally on either side of the shoulder during the process of polishing, and uniform pressure exerted along the pivot. The polisher must be used with a backward and forward motion, and with a slightly lateral motion, also, to prevent ridges being cut in the pivot.

HOW TO MAKE GROUND GLASS.—"I desired to have several pieces of ground glass," says a correspondent, "to use for some purpose. I first bought five cents' worth of emery, and two plates of glass of the size required. Spoiled negatives will answer, if they are cleaned, which can be done with a strong solution of lye. I placed one of the glasses on a flat board and sprinkled a small quantity of emery on it, which I wetted with water. Placing the other glass on that, I ground them together, renewing the emery and water when necessary. In about one hour I had two of the finest quality of ground glasses, fully as good as I would have to pay seventy-five cents for, 8 x 10 size."

TO FASTEN THE BALANCE SPRING.—The inner coil of the balance spring around the collet must be at a sufficient distance from the latter, so that there is no danger that it will either touch this or the place of fastening in the folding of the spring. This contact, which betrays itself by a jerking similar to the cracking of a whip, would cause an acceleration of the large vibrations.



* A Complete History of Watch and Clock Making in America.

[By CHAS. S. CROSSMAN.]

Number Thirty-Nine.

Continued from page 89, October, 1889.

WATCH CASE MAKING.

MARINE CHRONOMETERS.

THERE IS no branch of the horological industry in America where such great difficulties arise in trying to write a complete and authenticated history, as arise with reference to chronometers. In the first place owing to the great decline in American shipping this branch of the business has suffered greatly, and those who are at present engaged in it are, as a natural result, not as ready to speak as they otherwise would be. The way in which the manufacture is carried on also causes some to be somewhat conservative on the subject, and it may be well to state in this connection that the plates or frames, together with the trains, fuzees and chains for the greater portion of all chronometers, are made in England, and are a separate branch of business from chronometer making proper, as those who do this work take these plates, trains, fuzees and chains and finish them, and not only make the escapements and sometimes the balances, but do the adjusting. The dials are also made and engraved and the name of the maker generally put on them, although in some instances the name of some English maker is put when it is better suited to sell the chronometer than the maker's name, but it should be said in justice to the best American makers that they use their own names exclusively, and that the tests to which the chronometers are subjected show that they are equal in every respect to the best makes of other countries.

Another difficulty which comes up in connection with chronometer making is the peculiar manner in which much of the work was formerly done, much of it being done at the homes of the workmen, and the names which appeared on the dial of the chronometer, therefore, were not always an indication where or by whom the work was really done. But the chronometers made at present are almost entirely made by the persons or in the shops of those whose names appear on the dial.

Some would say that no chronometers are made in America entire. To this we would answer that while a few have been made here entire, it is true that for the most part they are not made entire. On the other hand, because a chronometer has the name of an English or foreign maker on its dial, it is no surer indication that he was the maker of that chronometer *entire* than if it bore the name of an American maker, for, as previously stated, a few firms make the greater part of the frames, trains, fuzees and chains for the firms who finish them, in England as well as in America.

WM. BOND & SON AND SUCCESSORS.

Wm Bond & Son, of Boston, are the only manufacturers of chronometers in New England, and the firm is the oldest in that business in America. The family were for generations prominent watch and clock makers in England prior to 1788. In that year William Bond moved to Portland, Maine, and five years later, in 1793, established the business in Boston at 154 Marlboro' street, or, as it is now named, Washington street. In 1810 the business was removed to 26 Congress street, where it remained for forty-two years, the next change being to 17 Congress street, and in 1876 to 97 Water street, the present location. The business is now carried on by the fourth generation of William Bond's descendants, and at no time has the firm been represented by other than members of the family. From the very beginning the members of this firm have been largely identified with the improvement and development of the business in America. They were the first importers of marine chronometers, then invented in England, and in 1812 William C. Bond, the son of William Bond, and afterwards Professor of

Astronomy and first director of the celebrated observatory of Harvard College, Cambridge, made with his own hands the first marine chronometer ever produced in this country. It was a unique instrument, for as no steel suitable for large mainsprings could be procured here at that time, he arranged it to run by a heavy weight, which moved on three guide rods to prevent its swinging from side to side with the motion of the vessel, the fall of the weight being about six inches and the chronometer running thirty hours. This construction necessarily makes it more cumbrous than those now made, for the brass box is twelve inches deep and the wooden box fifteen inches high and square.

A DESCRIPTION OF THE BOND CHRONOMETER.

The oval spring on the frame of the weight comes up against the bar which drives up the vertical pin, passing through a hook stop pin attached to a stud. The shoulder drives up the hook which comes up into a cut with a square edge on it in the collet fastened to the winding pinion. It winds with a right angle gear from winding post to winding pinion like a full plate stem wind American chronometer. A cat gut cord runs over the pulley as it comes from the drum to the pulley on the framework of the weight, which is made of a brass rim with a large leaden disk between, all bolted together, and is flush with the outside of the brass rim, as will be seen in the cut. The frame on the top consists of an open framework the same in diameter as the rim proper, and bolted to it by small bolts running through the weight. The cut represents the weight half run down. The balance is similar in appearance to those used in chronometers at that early day a chronometer balance, but much lighter than those used now, having four small steel screws on each side, with one tiny screw at the end of the arm much larger

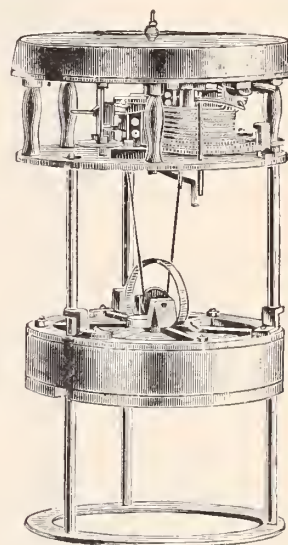

than the others. A closer examination reveals the fact that it is made in sections or parts, the arms being clamped to the rim. The hair spring is a flat spiral of four coils. The escapement is all steel, the scape wheel included, as there are no jewels except those on which the pivots of the balance run. It has a six inch dial silvered, with ordinary steel hands.

This chronometer was tested on a voyage to India by Lieut. Thos. B. Curtis, U. S. N., and its performance was so satisfactory that on its return the government offered a large sum for its purchase, but Mr. Bond would not part with it. It is still carefully preserved by the present firm, and attracts much attention by the contrast it affords with their more modern instruments.

William C. Bond also suggested to his correspondents in London numerous improvements in the construction of chronometers and watches, many of which were adopted and are now regarded as essential to proper performance of these instruments. The addition of the chronometer balance and chronometer escapement to watches were two of these; he imported the first chronometer watches made, and it is almost certain from letters of F. B. Adams, of London, between the years 1800 and 1820, that the firm introduced also the first lever watches brought to America.

Accuracy of time depends on accuracy of longitude, and soon after the Cambridge Observatory was established, the U. S. Coast Survey, recognizing the great importance of determining its exact longitude from Greenwich, in order that it might serve as the initial point in their operations, arranged several chronometric expeditions during the years 1850 to 1855. In these fifty chronometers at a time were transported in the mail steamers from Cambridge to Greenwich, carefully compared there and brought back again on the

George W. Shiebler,
Silversmith,
No. 8 Liberty Place,
New York.



Carnation.



Buttercup.



SOUP.
Fuschia.



OYSTER.
Narcissus.



Garden Lily.



Orange Blossom.

"FLORA."

EACH DESIGN

PATENTED.

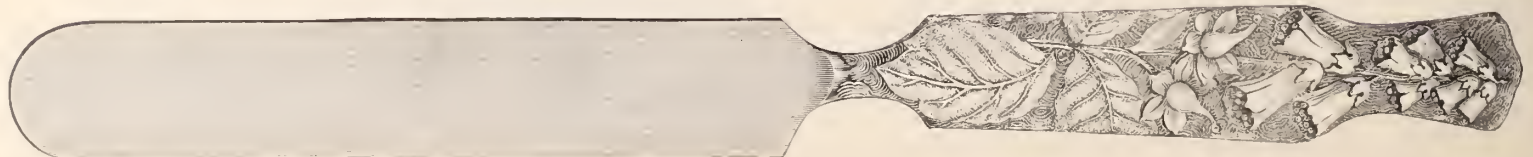

Foxlove

George W. Shiebler,
Silversmith,
No. 8 Liberty Place,
New York.

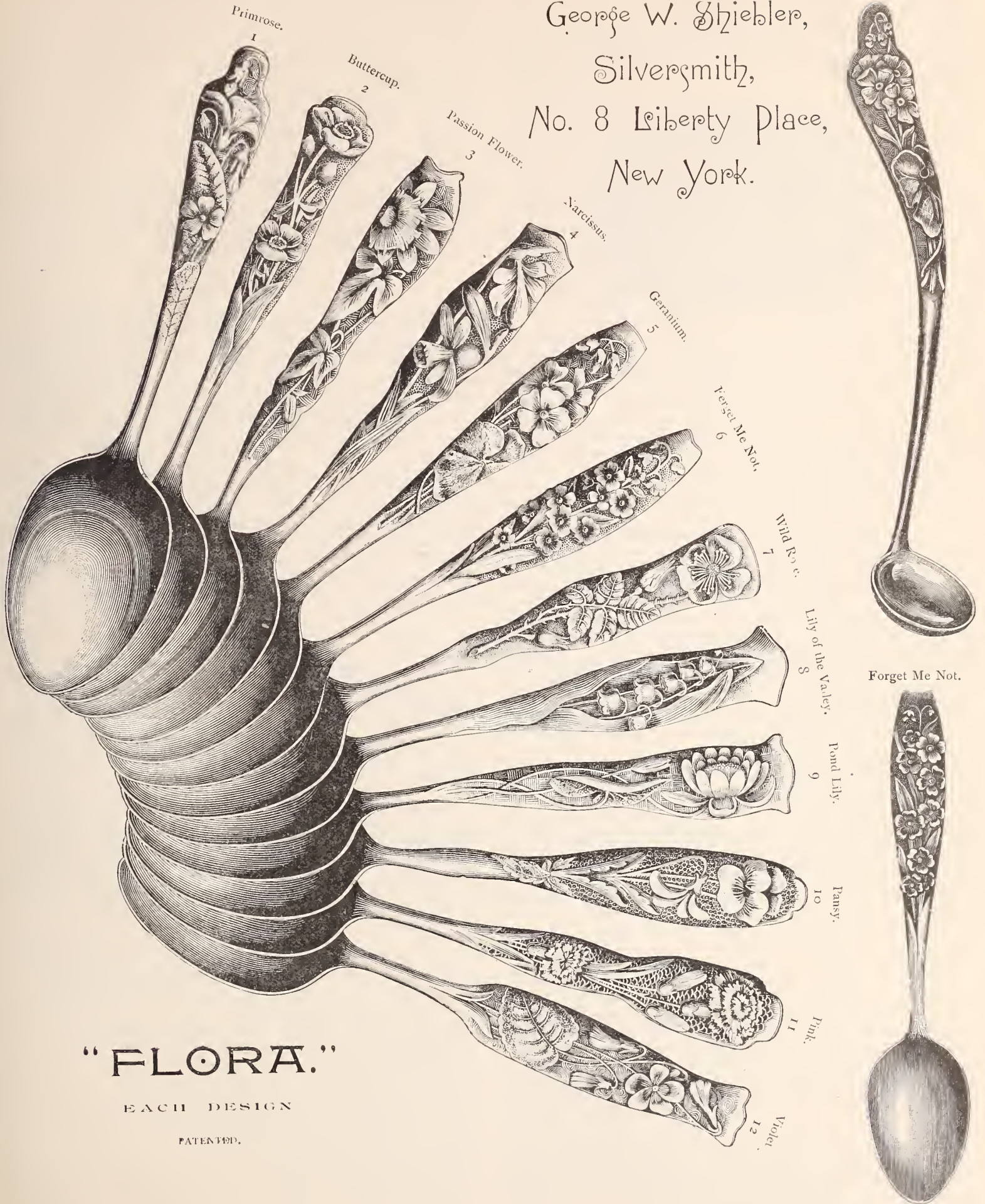

"FLORA."

EACH DESIGN

PATENTED.

return trip, all the instruments and appliances being furnished by Wm. Bond & Son, and Richard F. Bond himself taking charge of one expedition. This work was so carefully conducted and the result obtained was so accurate, that when after the ocean cables were laid and the longitude was determined by direct telegraphic signals with Greenwich, the difference was found to be almost imperceptible, amounting to only thirty-two one hundredths of a second.

As soon as the longitude of Cambridge was determined, the observatory was connected through the telegraph lines with all the prominent places in the country and their longitude found by exchanging clock signals, the operator tapping off the seconds of the clock by hand; but Mr. Bond soon invented an arrangement by which the clock should send the signals itself, saving much time and ensuring greater accuracy, and in 1850 he finished the first break circuit clock ever constructed. Still the signals had to be read by the ear, but within a few months his son, Richard F. Bond, invented the spring governor recording instrument, in which the movement of the cylinder, on which the clock signals and observations are recorded by electricity, is so beautifully regulated by the spring governor that it revolves continuously at a uniform speed, the most delicate tests failing to show an error in its motion greater than the three hundredth part of a second. This instrument, and the break circuit clock, were taken to London in 1851 and exhibited at the World's Fair, where they excited the greatest interest among astronomers and scientific men, and the spring governor received one of the twelve grand council medals awarded to this country. The spring governor was afterwards applied to the driving clocks of large telescopes with such success that they could be kept on a star for an hour at a time, rendering possible the photographing of the celestial bodies, which before could not be accomplished.

During the next ten years Richard F. Bond invented several gravity escapements which were applied to numerous standard clocks constructed for the government and various observatories, all of which have won for themselves well-deserved reputations for accuracy. Among his other inventions at this time, also, was his automatic oven for testing chronometers, which regulates itself with such delicacy that the heat never varies a degree from the required temperature.

In 1861 he invented a detached escapement for clocks, in which the scape arm when locked is entirely detached from the rest of the train, which continues to run, its speed being regulated by a rotary pendulum or governor, and as the arm rests on the pallet merely by its own weight, the force necessary to unlock it is reduced to a minimum, and the hands being moved by a cam on the arbor of the scape arm while it is being carried round by the clock and free from the pendulum, the latter vibrates as nearly as possible with perfect freedom.

Three of these clocks were constructed, the first one being sent in 1867 to the Paris Exhibition, where it was much admired for its novelty and exquisite workmanship, the movement being entirely exposed under a glass case; it received the highest award given to instruments of this class. This clock is now in the Observatory of Harvard College at Cambridge, sending time signals daily all over New England. The second clock on this plan was made for the Observatory at Liverpool, England, and its record is the finest of any clock in the world, the following being the average daily rates for five months in 1876:

Mean daily rate, gaining	March.	April.	May.	June.	July.
	s	s	s	s	s
	0.06	0.05	0.07	0.08	0.08

and the third clock is now in the window of the firm's place of business.

In the extensive surveys of our country carried on by the government, accurate timekeepers are of the first importance for the determination of longitude; the electric clocks, although made as compact as possible for field use, were inconvenient and expensive to transport, and much time and labor were spent in setting up and regulating them at each new station, so it was soon evident that a break circuit chronometer had become as great a desideratum as the break circuit clock had formerly been. Many plans for accomplishing this were proposed, but it was feared that the arrangement would have to be on too small a scale to give satisfactory results, and also that the attachment might seriously affect the performance of the instrument; but finally in 1870, after two years of experiments, Wm. Bond & Son succeeded in perfecting and applying to chronometers a modified form of their clock break circuit. It was then found that the passage of the electric current through the instrument did not cause any injurious effect as had been feared, but in every case the performance of the chronometer has been improved by its application. There is

no question that with the single exception of the Bond spring governor for regulating rotary motion, this break circuit attachment for chronometers is the most important addition to horological instruments for scientific use since the invention of the chronometer itself.

The world-wide reputation of Wm. Bond & Son is shown by the fact that their instruments are in use in the observatories of Liverpool, England; Cape of Good Hope, Africa; Pulkova, Russia; and Cordova, South America; besides many public and private observatories of the United States, and also by the Naval, Topographical and Coast Survey Departments of the U. S. Government.

Wm. Bond & Son have seldom exhibited their instruments in competition with others, but whenever they have done so they have invariably received the highest awards. The present firm, now located at 134 State street and at 94 Boylston street, is composed of Mrs. S. A. C. Bond, J. Morton Clinch and Wm. C. Bond, fourth generation (in America). They are an aggressive, wide-awake house.

(To be Continued.)

The New York Jewelers' Association.

The inducement offered to new members in the remitting of the initiation fee until the first twenty-five applicants for membership before January 1, 1889, are admitted, is working with extraordinary good effect. Seven new members have been admitted, J. T. Scott & Co., Cox & Sedgwick Mfg. Co., Howard & Cockshaw, Unger Bros., Ludwig Nissen & Co., New York; Simons, Bro. & Co., Philadelphia; L. Lelong & Bro., Newark, N. J. Inquiries are rapidly coming in.

The Executive Committee has been meeting every Friday to complete arrangements for the annual dinner which will take place at Delmonico's on November 21. An entirely new departure will be made in the form of the invitations, which will be both unique and artistic. This is the crystal anniversary of the Association, which was organized in 1874.

The following letter received by the Jewelers' Association from the Finance Committee of the International Exposition of 1892, will explain itself:

INTERNATIONAL EXPOSITION OF 1892.

COMMITTEE ON FINANCE, No. 36 Nassau street,

NEW YORK, October 25, 1892.

F. S. Douglas, President of the New York Jewelers' Association:

DEAR SIR—I have been instructed by the Committee on Finance of the International Exposition of 1892 to transmit to you the enclosed subscription book, and ask the favor of you to appoint a suitable person in your Association to take charge of the same and receive subscriptions to the \$5,000,000 Guarantee Fund.

The Committee also request the favor of you to send to the undersigned, at the rooms of the Chamber of Commerce, 36 Nassau street, for publication, a daily report of the subscriptions received.

Very respectfully, GEO. WILSON, Secretary.

Thereupon the Jewelers' Association prepared a circular to be sent to the trade generally, announcing the opening of the subscription books. The following is a draft of this circular:

NEW YORK, October 25, 1892.

To the Jewelry Trade of the United States:

Referring to the annexed communication of the Finance Committee of the International Exposition of 1892, appointing the New York Jewelers' Association the official medium for receiving subscriptions, we respectfully announce that the subscription book has been received and opened at the office of this Association, 142 to 146 Broadway.

This circular has been sent to the trade generally, and it is hoped that by a concentration of subscriptions the importance of the entire trade will be emphasized and receive the recognition it deserves.

We solicit the prompt and generous contributions of all who are willing to aid in raising this guarantee fund, and it is hoped the response will be cordial and enthusiastic.

Very respectfully,

FREDERICK S. DOUGLAS
J. B. BOWDEN,
WM. H. ATWATER,
ALFRED H. SMITH,
GEO. C. WHITE, JR.

Executive Committee

We concur in the above appeal to the trade and approve the suggestions made therein.

C. L. TIFFANY, } of the General Organization Committee
D. F. APPLETON, } of the International Exposition of 1892.

In order to correct misapprehensions that may have gone abroad in reference to the appointment by Mayor Grant of Charles L. Tiffany and D. F. Appleton to represent the jewelry trade on the committees of the World's Fair, Secretary Pritchard furnishes us with a review of the facts that led to the appointment. At a meeting of the Executive Committee held Wednesday, July 31, 1888, the subject of the World's Exposition of 1892 was discussed. It was decided that a petition in the form of a letter be presented to the Mayor by Alfred H. Smith, and that the aid of Gen. W. T. Sherman be invoked in the interest of the Association, the object being to induce the Mayor to appoint on the committee having the matter in charge some member of the New York Jewelers' Association to represent the jewelry industry and its kindred lines. The petition named D. F. Appleton, of the American Watch Co. The following letter was sent to Mayor Grant:

To the Hon. Mayor Grant:

July 31, 1888.

DEAR SIR—In exercising your duty in selecting from the different trades and industries, members of the committee on the "World's Exposition," we respectfully desire to call your

attention to the important interests represented by the New York Jewelers' Association. This Association is one of the oldest trade organizations in the country, and includes in its membership most of the largest and most important manufacturers and importers of watches, diamonds, jewelry, silverware, electro-plate, clocks, optical goods and other similar branches connected with the trade.

At the Centennial Exhibition in 1876 and at the present Paris Exposition, the largest and most important exhibits were made by members of this Association, and we therefore respectfully request that you will carefully consider the matter and appoint as the member of the committee to represent this trade one who is well known and who will be a representative man.

In this connection we beg to suggest the name of Daniel F. Appleton, of the American Watch Co., No. 3 Bond street. Mr. Appleton is a gentleman of rare business qualifications, and if you have not the pleasure of his acquaintance, any inquiries you may be pleased to make will corroborate the value and the fitness of our suggestion.

We trust you will give this matter your careful consideration, and appoint one who is recognized as one of the foremost men in the trade we represent.

Very respectfully yours,
ALFRED H. SMITH,
JOSEPH B. BOWDEN, } Executive Committee.
GEORGE C. WHITE, JR., }

In the absence abroad of the President, H. Blanchard Dominick, and the Vice-President, A. K. Sloan, this communication was signed by the Executive Committee.

The Jewelers' and Tradesmen's Company.

Directors Woglom, Cottle, Johnson, Saxton, Roberts, Smith and Baldwin attended the quarterly meeting of the Board on Monday evening, October 21, and listened to the statistical reports of the executive officers. The life insurance or benefit fund in the United States Trust Company exceeds \$3,000, the reserve fund in the same depository is over \$1,000, and the membership roll has reached beyond 800 and still growing.

During the last month those admitted to membership are: Charles H. Fitch, Whiting Mfg. Co.; Edwin J. Beames, Gorham Mfg. Co.; Charles L. Krugler, Kimball & Co.; Henry T. Gray, cashier Bradstreet Company; Charles J. Evans, Leonidas W. Hurtt; William A. Hoe, James C. Hoe & Sons; Louis Krug, L. Krug & Co.; Charles Kosinsky, —; Henry Loeb, H. Zimmer & Co.; James A. Rierdon, E. W. Jones & Co.; William Rowland, J. Rowland & Sons; Augustus L. Siefken, American Express Co.; George Germaine, United States Express Co.; Charles Engler, Charles Glatz; William E. Truell, Smith & Egge Mfg. Co.; the above of New York City; and John Curran, J. Curran & Co., Brooklyn, N. Y.; Oliver B. Upson, J. Coatsworth & Son, Galena, Ill.; Patrick H. Kennedy, Charleston, S. C.

The sessions of the Executive Committee, for the supervision of applicants, are held on Wednesdays of each week.

Quaker City Paragraphs.

PHILADELPHIA, Sept. 10, 1889.

The Philadelphia local branch of the National Wholesale Jewelers' Protective Association at a meeting held at Guy's Hotel, Philadelphia, on the 4th inst., elected as their representatives on the National Executive Committee Mr. Morris Pfaelzer, of Pfaelzer Bros. & Co., and Mr. David F. Conover, of D. F. Conover & Co. The meeting in question was very fully attended, and the subscribers to the constitution and by-laws of the new association included all the large and small wholesale jewelers of Philadelphia without a single exception.

Hollinshed Bros., 806 Chestnut street, have a new lithographed business card that is a model of taste and neatness. This house is just now making a leader of a chain which they claim to be the equal of any in the market, quality and price considered. Cuts of this chain appear on another page of this issue.

David F. Conover & Co., are ready to meet all calls for their new material, optical and spectacle catalogue for 1890, and retailers are requested to send in their cards, for they can rest assured that it will be sent to the legitimate trade only.

James W. Queen & Co., the well-known optical house, have just won a suit for excess of duty in the United States Circuit Court that is of considerable importance to the optical and kindred trades. Queen & Co., have a department in their store devoted to philosophical instruments, most of which are imported. Some time ago they imported a lot of these goods, including field glasses, thermometers, marine glasses, surveying instruments, opera glasses, etc., and were compelled to pay 45 per cent. duty on them, this being the rate assessed on manufacturers of glass and metal. The house claimed that the imports came under the head of philosophical apparatus and should have been assessed at 35 per cent., and accordingly brought suit to recover the alleged excess. The result was a verdict for Queen & Co. for the full amount claimed.

Business has been so good with M. Zineman & Bro., the "Diamanta" optical house of 130 East 9th street, that they will find it necessary to call their travelers in on the first of November nearly a month earlier than usual. This fact speaks well for the popularity of the "Diamanta" goods. This house is preparing to engage extensively in the manufacture of aluminum for use in their spectacles and eyeglasses.

Horological School Notes.

We start our column of horological school notes this month by showing our readers a cut of a "Grossman Lever Escapement" model made by a student of the Chicago Horological Institute, H. L. Dickson, Pittsburg, Texas. It is a beautiful piece of work and speaks very highly for him as a workman, and for the instructors of this school.

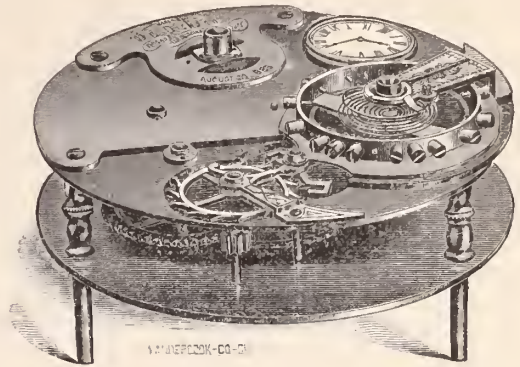

The management of the Chicago Horological Institute announce that those who are to become students in their school after January 1, 1890, would do well to send in their names as soon as possible prior to that time, as so many have signified their intention of entering the school after that date, that they are anxious to be prepared for all comers.

The Chicago Horological Institute are going to offer several "Webster Whitcomb" and Mosely lathes for competition by the students the coming winter, commencing in January and February next. The prizes are to be awarded to those who show special progress. The terms of competition will be given in the December CIRCULAR.

Student Carlos Herzog, a young Spaniard in the Chicago Horological Institute, probably comes the greatest distance for his watch-making instruction. He belongs in Guayaquil, the seaport of Ecuador, South America. He has a watch under process of construction, half as large again as an 18 size movement.

The Chicago Horological Institute was the recipient last month of a demagnetizing machine, presented by the Berlin Demagnetizing Co., of New York. The management say it works perfectly and does all the manufacturers claim for it, and that they would not be without it.

Dr. Meyer has commenced a series of twenty-five optical lectures before the students of Hutchinson's Horological School, La Porte, Ind. Tuesday and Friday evenings of each week are devoted to this purpose, and the students are manifesting much interest in the subject. This course can be taken independently if desired.

The Parsons Horological School, La Porte, is about to move into the new building that has been constructed with a special view to its requirements.

The American Horological Institute, Philadelphia, Pa., have rented a large, well-lighted room at No. 1,723 Chestnut street, which they are fitting up with every convenience and appliance that will be needed to make their facilities for giving horological instruction as complete as any. The location is excellent. Already a number of pupils have matriculated, and by January 1 the proprietors expect to be in good working order. Instruction is not confined to watch making alone, but includes jewelry, engraving and every other branch necessary to fit a young man to take charge of a jewelry business to-day.

Students Wood and Houston, of Hutchinson's School, La Porte, are each building a pocket chronometer watch, constructing their own special tools. One of the watches is a solid nickel 16 size movement, full jeweled, with gold settings and jeweled center, and has a non-magnetic balance and hair spring, the only parts not made in the school being the two latter and the mainspring and patent center pinion.

A MAMMOTH CATALOGUE.

—S. F. Myers & Co., of 48 and 50 Maiden Lane, New York, announce the publication of their new illustrated catalogue for 1890. It is an elaborate and handsome volume of 364 full quarto pages, equal to 728 pages of the average octavo size. It is bound both in heavy board and fine cloth, gold embossed covers. Of the cloth bound edition they issue also a special, known as *The New York Jeweler*, which is practically a nameless catalogue, as that name appears alone to identify it, together with the customers name in letters of gold on the outside. The paper is of very heavy quality, super-calendered, with a handsome smooth finish. The new catalogue is enlarged considerably over their 1889 issue. It weighs

nearly six pounds, has over seven thousand wood engravings and more than seventy thousand separate quotations of prices, embracing a variety of goods belonging to the jewelry and kindred trades that is little short of marvellous, representing the twenty-two departments into which S. F. Myers & Co. have divided their establishment. The prices in the new book are quoted at long or list figures, which is a great protection to the retailer, as no clew to the discounts are obtained, this information being enclosed in sealed envelopes to those who receive the book—an invariable rule of the firm. We quote from their introduction the following lines, which, from our own knowledge of the growth of the concern, we know to be a fact: "We take a pardonable pride in stating that our yearly sales for the past ten years have shown a uniform increase, the marked necessities of our business having compelled us to enlarge the capacity of our salesrooms no less than five times within that period." They claim, and justly, too, to have set the pattern for popular prices on reliable goods, the quotations in their publications having become the standard for close buyers, their margin of profit being based on the aggregate minimum expense of their many departments. This standard work for the New York market is sent free to the customers of the firm and to other dealers in the trade *upon request*. All dealers should have a copy of it if only for comparison.

THE "ANTI-SWEAR" ON TOP.

—In all branches of business it has been demonstrated time and again that the introduction in the market of a new and useful patented article brings in its train innumerable infringements and imitations. This rule applies to no trade more than that of jewelry manufacturing, it being especially true where the device has proved successful, and bids fair to become popular. An illustration of this abuse of the patent laws is afforded by an infringement suit just settled by J. T. Scott & Co., 4 Maiden Lane, New York. Among the many products of this house is the well-known anti-swear cuff button, patented and owned by them, which, since its introduction has commanded a remarkably large sale. Some time ago the firm learned that G. Felsenthal, of Felsenthal Bros. & Co., Louisville, Ky., had secured a patent for a button that plainly infringed upon the anti-swear; immediately they determined to protect their rights and those of their customers to the fullest extent of the law, and to demonstrate to the trade that they were ever ready to do so, Scott & Co. instituted suit against Mr. Felsenthal, the outcome of which is that they have become the owners of the latter's patent, and now control everything that bears any resemblance whatever to their celebrated anti-swear cuff buttons.

Obituary.

WILLIAM W. WEIL.

When the statement was spread through the trade on the morning of Oct. 14, that William M., popularly known as "Billy" Weil, was dead, it was hardly credited; but inquiries at his place of business proved the truth of the rumor, and genuine sorrow was expressed from all sides for the deceased was ardently esteemed by all who had known him in life, and they were legion. His death was very sudden and unexpected, as he had but returned from the West in his usual robust health on the Friday previous, and had attended to his business duties on Saturday. The sad end came at about 4 o'clock on Sunday morning.

William M. Weil first saw the light in London, Eng., fifty-four years ago. He was of German parentage. When about 18 years of age he came to New York, and for several years experienced all the hardships of a young foreigner in a metropolitan city. He at last drifted into the jewelry business in an itinerant way, making San Francisco his headquarters. In 1873 he came back to New York and became a salesman for E. Aug. Neresheimer & Co., on commission, but it was not long before he became a salaried salesman. He was admitted into the firm as a partner in 1879, but withdrew in 1885.

The popularity that Mr. Weil enjoyed, though he bore an enviable reputation for sterling integrity, business ability and generosity, was largely founded upon the many happy traits he possessed, which endeared him to all with whom he came in contact.

The funeral services took place on the 16th at Woodlawn Cemetery and were attended by a large concourse of jewelers.



[THE CIRCULAR is not responsible for the opinions or statements of contributors, but is willing to accord space to all who desire to write on subjects of interest to the jewelry trade. All communications must be accompanied by a responsible name as a guarantee of good faith. No attention will be paid to anonymous letters. Correspondence solicited.]

"DO WE MAKE WATCHMAKERS TOO FAST?"

La Porte, Ind., Sept. 24, 1889.

To the Editor of the Jewelers' Circular:

My attention has been called to an article in your valuable journal written by J. W. Hall, of Cazenovia, N. Y., and I feel constrained to give my views on the subject. I do not think we are making watchmakers too fast. Mr. Hall says in his letter that the young man with three months' experience in a jewelry store starts in business and the majority of the watch-carrying public take their work to the new fellow.

I think we ought to make first-class workmen in our horological schools in a few months that would quickly take the places of such as Mr. Hall mentions. The incompetent workman is soon found out and his business dwindles away, while the competent workman continues to do good work and ultimately succeeds, and if we can graduate a sufficient number of competent workmen each year, the incompetent workman *must go*.

He says, further, that he heartily endorses the horological school movement. Then let him, and everyone else in the trade, if he or they are not already doing so, endorse every competent workman (whether graduate or not) of our horological schools. Some three-months' students are very competent, and many that become proficient but do not stay long enough in the schools to get a diploma, are entitled to recognition as competent workmen. He asks: "Are we not too fast in certifying that the three-months' graduates (not *graduates*, but *students*) of these schools are qualified to take up every class of watch work and do it as it should be done?" I answer, *Yes*. Three-months' students, as a rule, are not able to do all kinds of watch work as it ought to be done, but they are better qualified to do what they have been taught in their three-months' course in a first-class school than the store apprentice is after three years' work. I know this from experience. I have met many watchmakers in the past twenty years, and I served with two as good men (so recognized) as there were in the state at the time I was an apprentice.

I have had in my school some students that only remained three months (I do not call them graduates). They can do better work, and do it with an understanding of the principles involved, than most workmen of ten years' experience. Why? Because they are taught every detail of the construction of a watch from barrel arbor to hairspring, learning every part as a separate piece as well as its position and connection, and those that study with a determination to master the work and know the whys and wherefores, do not have to repeat a majority of the more simple operations more than a few times before they become thoroughly familiar with them. Then they are able to devote every remaining hour of their time in school to a thorough and systematic study of the finer and more difficult operations. With these parts thoroughly learned and a full knowledge of how to file, turn, polish, etc., they are able to go into the field and compete with the better class of watchmakers, and are fully entitled to a liberal share of the confidence of the trade and the public generally. And the trade should be the first to recognize and assist such to good positions. I can give the names of a few such as are mentioned above who hold good positions in large towns

and cities, and have from the time of leaving my school a year ago until the present, and will likely continue to do so for some years to come.

Mr. Hall suggests a uniform course of study. It is by all means desirable, and is now so recognized by a few. I have always had a regular and systematic course of study, and carried it out with all my students the same. Such a course should embrace physics, chemistry, mathematics, mechanical drawing, optics, engraving, tool making, model making—in short, every detail of watch work, watch case, clock and jewelry repairing and making, and every *graduate* should draft and make complete a new watch movement from the raw material, besides all other work in the study course, before he is entitled to receive a diploma. Let the time be not less than one year; it need not be more than two years, and with proper evening classes there will be no need of the cramming process mentioned. Students, as a rule, do not retain methods taught in haste.

If the smart young man or student has had thorough drilling in the handling of hairsprings and can do successful work in that line, he is able to learn the theory of isochronism in a short time and retain it, but he will need considerable practise with his theory to enable him properly to judge of and locate many errors that he will encounter while testing watches in these adjustments. The attempt should never be made to teach adjustments to any student who is not competent to handle a watch intelligently, and also be able to properly adjust the escapement in every detail; also the balance spring, to locate and correct all existing errors. When he has mastered this work, and can repeat the operation successfully without assistance, he can be taught adjustments in temperatures, isochronism and positions, and work intelligently. There are many young men with good heads who if left to themselves will seldom develop into good mechanics, but if placed under a competent instructor they very soon distance the majority in the same work. I do not think it proper for a young man with such abilities to be allowed to waste his time in trying to develop himself. Let some generous heart provide for the young man's schooling (if he cannot pay his own way). Very seldom would a case be found where the person so assisted would not return proper acknowledgment for the favor shown.

A good common school education is to be desired in all students, but it is not positively required; neither is a knowledge of geometry, as can be proven in the cases of many superior workmen. To be a master workman and possess a thorough knowledge of mechanical engineering, requires special education, but give me a hard-working, thinking student, and I will make a competent workman of him in a few months.

It is needless to say that no graduate of any school, either collegiate or mechanical, has reached the top round of the ladder when he receives his diploma, but if he has received his instruction from one that has knowledge and teaches thoroughly, he has received the principles of the trade he intends to follow, and, understanding them thoroughly, is ready to put into practice what he has learned, and by diligent work and improving every opportunity will soon be recognized as master of his chosen profession.

J. L. HUTCHINSON.

AN AMERICAN CRITIC ON THE EXPOSITION AND THE AWARDS.

To the Editor of the Jewelers' Circular:

The writer having recently spent some time among the exhibits of jewelry, silver and plated ware, novelties, etc., at the Paris Exposition, it may interest your readers to know what is thought of them by visitors, by the juries awarding prizes, and by their competitors. It might suffice to say that upon all hands it is

conceded that the American exhibits in the line of jewelry, silver and plated ware, and all that pertains to the jeweler's and silversmith's arts, show more originality and artistic workmanship than any similar exhibit from any other country. The verdict is unanimous in this respect. If we take the exhibits of the French, the Italians, and other nations, we see here the same styles that have been in vogue for fifty or a hundred years reproduced in almost precisely the same styles with which we have so long been familiar with scarcely any deviation. Nothing new is presented to indicate any progress in the arts since the exhibition of 1878. So far as the exhibits of the Paris jewelers are concerned, their cases are gorgeous with precious gems and art work. But in the entire collection it is impossible to find anything that is essentially new. The designs, the forms, general style, all are old, and in passing through the long line of cases, while one is dazzled by the glitter of the show, he cannot repress the feeling that he is among the shops of the Palais Royal, or seeing again the vision of the Centennial Exposition in Philadelphia. He who saw what Paris did at the Philadelphia Exposition saw all that Paris does at the Exposition of 1889. More than all, many of the richest gems displayed were borrowed for the occasion, and are not even owned by the exhibitors. Italy, whose exhibit in 1878 attracted so much attention in Philadelphia, has virtually repeated herself, and appears in Paris showing no progress, no attempt at new creations. As to Japan, of whom we expect novelties in decorative work, lacquers, porcelain, etc., she evidently exhausted herself at Philadelphia, for the exhibit this year is far inferior to that of our own exposition. In fact, it is probable that we never again shall see the rare examples of Japanese works that we have been made familiar with in previous years, for Japan is becoming Europeanized, and instead of developing her own artistic taste, she imitates the work that is now *passé* in Europe.

Very different from all this are the American exhibits. Take, for example, those of Tiffany & Co., which have attracted such marked attention from hundreds of thousands of visitors during the past six months. In their cases are to be seen specimens of such exquisite workmanship that they mark an epoch in the history of the jeweler's and silversmith's arts. More progress is shown by this and the Gorham firm than has been made by any other nation in the past fifty years. In enamel work, wherein France has heretofore held the palm, Tiffany & Co. show specimens so far in advance of what has been seen before that the French workmen are entirely distanced. For example, they show a number of orchids in precious stones, gold and enamel, that are so perfect in every tint and shade of color as to lead one to think he is gazing upon the natural flower. These, enriched with precious stones, graduated in size and color to the proper shadings, add lustre and beauty to work that seems perfect without them. In a great number of other articles the advance made by American workmen is emphasized to an extent that commands the admiration of all beholders and excites the envy of all competitors. Their silverware for household use and table decoration, with its artistic chasing and etching, together with their enamelling and inlaying of metals, were well deserving of the Grand Prix awarded them by the jury. In all, Tiffany & Co. take fifteen gold, silver and bronze medals in addition to the Grand Prix—the highest honor that can be awarded by the management of the Exposition.

In addition to the exquisite art work shown by this firm—every feature of which, from the designing to the finishing, was executed in the factories of the company and upon their own premises by their own workmen—they exhibit a very large collection of precious and ornamental stones of North America, consisting of stones cut in the United States, which have been gathered by Mr. George F. Kunz, who stands at the head of mineralogists in this country. He has also gathered for this exhibit a great variety of pearls, which are shown with the various species of shells in which they are found in North America. In leather goods and stationery this firm also make

an exhibit that places them at the head of manufacturers of this class of goods, for which they receive a gold medal.

The exhibit of the Gorham Manufacturing Company is quite as marked in its line for originality and artistic workmanship as is that of Tiffany & Company in their several lines. All the work shown by the Gorham Company is original in design and treatment, and was on all sides conceded to be far superior in every respect to the workmanship of their foreign competitors. While the silverworkers of France have been reproducing the old styles and forms, the Gorham people have gone forth into new fields, and they have succeeded beyond the brightest anticipations of the most sanguine. The gold medal which they receive was the highest award that the jury could, under the circumstances, give them, as the Grand Prix had been awarded to Tiffany & Co. Many Americans have entertained the idea that for fine jewelry there is no place like Paris, and consequently are large patrons of the Parisian jewelers, and as Tiffany & Co. have spacious salesrooms and perhaps the most valuable and comprehensive stock of jewelry in Paris, and do a very considerable business, being direct competitors with the Frenchmen on their own ground, it seemed to be understood that it would be a blow to French interests to permit them to carry off the Grand Prix for jewelry, which it was conceded they were fairly entitled to, but that it must go to a French house. There was a deal more of this favoritism—or perhaps I should say commercial interest—involved in the awards than appears upon the surface. But when one considers that rich Americans have heretofore been among the choice customers of the Paris houses, it may be well understood that merit did not always win. It must be said of the juries, however, that in every instance they seemed most kindly disposed toward the American exhibitor, and wherever it was possible to do them full justice, without prejudice to French interests, they did so ungrudgingly and cheerfully.

Such was the case with the Meriden Britannia Company, which exhibited plated ware. The company decided at a late hour to make their exhibit, and consequently made no special effort for the occasion, but took their goods from their regular stock and displayed them in competition with foreign manufacturers, who had spent months in special preparation for this event. The originality of design and treatment of the goods shown by the American company, however, were such as to attract universal attention and excite the admiration of the jury of award. As a consequence, a gold medal was given the Meriden Britannia Company, which was all, if not more, than was expected. The company certainly did itself credit, and it was possibly quite as well for them that they did not expend their energies on special pieces for exhibition purposes, for the fact that the goods exhibited were taken from their regular stock was rather a point in their favor.

Leroy W. Fairchild was another exhibitor who was agreeably surprised by the judgment of the jury. His goods were entered in the class where were shown pens, penholders, pencil cases, etc., and the test of these goods was very severe. The committee not only examined the goods as shown in the cases, but asked to have samples sent to their rooms that they might give them a full and free trial in the regular course of their correspondence. There were many competitors, but the superiority of Mr. Fairchild's goods and the delicate and exquisite character of the workmanship were such that he was awarded the Grand Prix, much to the chagrin of his European competitors. But possibly the greatest surprise for Mr. Fairchild lay in the fact that the jury of award in the silver department, in which he was not entered and was not a competitor, were captivated with the fine workmanship shown in the various novelties exhibited, especially with the combination of gold and platinum and silver, and made a special request that he should enter in that class. Mr. Fairchild was reluctant to do this, but the jury proceeded to classify his goods, and as a result he received the award of a silver medal, which was the spontaneous and unsought-for reward given

by the jury for superiority of workmanship displayed in his great variety of novelties in small wares.

It is not my purpose to go through the list of exhibitors in the American department, but to emphasize the fact that our jewelers and gold and silversmiths have at this exposition by their work shown that American goods of this kind possess more originality in design, in material, and in workmanship, than those exhibited by any other nation. At the Centennial Exposition in Philadelphia our manufacturers, as is well known, sent their workmen by scores to visit the exposition, paying their expenses while they devoted days to the study of the work of all nations represented on that occasion. The result of this study and of this liberality on the part of the manufacturers is made evident at this Paris Exposition, for not only have our workmen improved upon what they then saw, but have created new fields of their own and have developed a degree of originality and artistic taste that was unsuspected before. There will be no occasion in future for Americans to go abroad for anything they may want in the jewelry, gold, or silversmith line. We are to-day as far ahead of the European nations in these matters as they were ahead of us twenty or thirty years ago.

I find that even among the exhibitors themselves there is some confusion as to what is meant by the Grand Prix. It was the original intention to confine the prizes mainly to bronze, silver and gold medals for individual exhibitors. But the Grand Prix was instituted to reward governments for their exhibits, and to recognize by this also the exhibits of scientific institutions, such as the Smithsonian of Washington, and others of a similar nature. But it having been demonstrated that individuals had done as much towards the advancement of civilization in many instances as either nations or scientific institutions, it was determined to increase the number upon whom the Grand Prix might be bestowed, and so the list was increased by the addition of individual names. Just what form this Grand Prix is to take seems to be in doubt as yet, even by the management of the Exposition. But the general belief is that it will be an elaborate gold medal, with possibly an added ribbon of decoration. It is the highest honor that can be awarded by the managers of the Exposition, and he who receives it is justly entitled to indulge in any amount of pride. In connection with the merits of the goods for which it is awarded, the record of the exhibitor is considered, as in the case of Tiffany, Fairchild and others, all of whom have exhibited on numerous occasions, always with credit to themselves and their country, and receiving high rewards of merit. While in some instances a gold medal might have been the highest award given, the fact that the exhibitor had an honorable record was taken into consideration. While the place occupied by the United States in the Paris Exposition was not of the highest, it was redeemed from utter failure by the enterprise of a few individuals, among whom those I have named take conspicuous rank.

It is pretty well understood that Mr. Moore, of the house of Tiffany & Company, will receive the decoration of the Legion of Honor for the interest he has shown in the Exposition and the part he has taken in preparing the Tiffany exhibit. Mr. Paulding Farnham, also of this firm, who designed the jewelry exhibited, will undoubtedly receive special honors before the season closes. The same may be said of George F. Kunz, whose scientific work in connection with the mineralogy of this country is recognized by the scientific societies of Europe, some of which are prepared to honor him with their recognition. I append a list of the awards given to our exhibitors in the jewelry and kindred lines, taken from the official list of awards. In conclusion I may add that our exhibitors speak in the highest terms of the assistance and uniform courtesy received from General W. B. Franklin and his associates on the American Commission. CLIFFORD.

ELECTRICITY.—The maximum intensity of the light from the Eiffel tower is 500,000 candles, giving a range of 127 miles.



TRADE GOSSIP.

—Koch & Dreyfus, 22 John street, are showing a very extensive assortment of diamonds this fall.

—H. G. Boesser, the well-known jeweler of Fort Smith, Ark., has moved from 407 to 411 Garrison street, that city, into a new and handsome store.

—Last month, John S. Birch & Co., of watch key fame, moved their factory from 184 Lewis street, New York, to more commodious quarters at 79 and 81 Washington street, Brooklyn, N. Y.

—William H. Ball & Co., bracelet manufacturers of 15 John street, have added to their line a full assortment of bead necklaces of the same undeviating quality and finish as their standard line of bracelets.

—J. F. Fradley & Co., manufacturers of gold-headed canes and gold and silver novelties, 23 John street, sell only to the legitimate jewelry trade. Their goods are never found in dry goods or notions stores, and jewelers can therefore feel secure from such competition in handling these goods.

—The plant of the Pairpoint Mfg. Co., at New Bedford, Mass., is running until 9 P. M. each night, producing goods to fill the largest number of orders that the company has ever had at this time of the year. Especially active is the demand for their large new line of nut and salad bowls in old silver finish, as well as their extensive line of novelties.

—Henry E. Oppenheimer & Co., 47 Maiden Lane, New York, whose offer of \$50 for the best design of a ring, evoked a great deal of competition among artistic jewelry designers and salesmen all over the country, received many original and striking suggestions, which their own designers are embodying into practical patterns which will soon be before the trade.

—Joseph Noterman & Co., 203 Race street, Cincinnati, O., have a large amount of orders on hand, their repairing and diamond departments being in receipt of a specially liberal share of patronage. In order to supply the trade with their celebrated Olympus diamond goods they are compelled to work at night, electric lights illuminating their work shops until well into the night.

—The active demand for piano and banquet lamps still shows no abatement, but rather an increase. The line of these goods displayed at the show rooms of the Bradley & Hubbard Mfg. Co. is undoubtedly the largest and most complete in the United States. Made in copper, bronze, wrought iron and silver finish, they combine excellence of workmanship with elegance of design, making goods admirably adapted to the requirements of the holiday trade.

—A new book entitled "Cycling Art, Energy, or Locomotion" has just been received by us. The author is R. P. Scott, formerly of J. W. Scott's Sons, Cadiz, O., and now a manufacturer at Baltimore. Mr. Scott was a correspondent on horology to this journal in old times, and has since made escapements at the Elgin watch factory. The invention of some labor saving machines has carried the once enthusiastic watchmaker into other lines, but he still takes a great interest in his old trade.

—A catalogue just issued by Flint, Blood & Co., Providence, R. I., is replete with illustrations of their widely-known 16 k. gold hard solder filled and rolled plated rings, a large number of which are new designs. The firm, as in the past, will constantly introduce new patterns to their lines, illustrations of which will be forwarded to the trade, which can be added to the catalogue by pasting them on the stubs, left in the book for that purpose. So the dealer having one of these catalogues will be kept constantly posted as to the firm's stock of goods.

—Frank Mauser & Co., silversmiths, of North Attleboro, Mass., are exhibiting some beautiful specimens of hand-chased work in repousse scroll work and rococo patterns now so much in vogue. Superb examples of this style of work are shown in toilet sets, shaving mugs, cups, cigarette cases, fine stationery novelties, napkin rings, match boxes, etc., as well as in hollow ware, such as berry sets, pitchers and bowls. They have recently patented a rococo design called the aigrette, which is one of the most ornate offered to the trade to-day. All of their handiwork is of sterling quality and finished in the highest style known to the silversmith's art.

—From what we learn, the Little Gem Drawing Machine for watch clubs, manufactured by Taintor & McAlpine, Easthampton, Mass., is not sharing the fate that very often befall novelties, conceived to improve the stores and windows of jewelers. Orders from the four points of the country have come in. The little gem is sold to jewelers exclusively, and is a useful, attractive and profitable article.

—Wade, Davis & Co., Plainville, Mass., manufacturers of rolled plated jewelry, have been rushed with orders since they started up last June, and indications point towards a continuance of this activity. They have increased their already extensive facilities by the addition of new machinery, etc., and are now in an excellent condition to fill orders promptly. The firm claim to have the largest and best line of goods they have ever produced, samples of which will be cheerfully displayed to the trade by Chas. A. Whiting, their New York representative, who is ever ready to oblige customers.

The gold case shop of the Waltham Watch Co., No. 5 Bond street, New York, was established about twenty-five years ago at the corner of John street and Broadway, by J. C. Comins, who had previously occupied a loft at No. 17 Maiden Lane. The business increased rapidly until as many as 400 cases a day were turned out, none below 10 karat. In 1871 the present quarters at No. 5 Bond street were taken, where three floors are required to meet the demands of the business, and about 600 men are employed by the company under the superintendence of J. E. Seering. The company first entered into the manufacture of cases as a convenience to their customers and also as a means of protecting themselves against the injury to their reputation resulting from the casing of their movements in inferior cases of various makes. They are now enabled to guarantee the complete watch when it leaves their hands.

—The Rogers & Hamilton Co., Waterbury, Conn., are distributing to the retail trade a new illustrated pocket price list of their staple wares. Besides cuts of the different patterns they have so successfully put upon the market and terse descriptions of the same, there are a number of announcements of interest to the trade. One of these calls attention to an improvement consisting in the use of specially prepared papers to put up the goods in. These papers, which are the result of much experiment, are impervious to the action of the atmosphere, thus preventing goods in stock from tarnishing on account of dampness or gases in the air. The different grades of ware manufactured by them are also distinguished by papers of different colors. A new trade mark, a scimeter, followed by the "Rogers & H. Co." and a designation of the quality, has been adopted to distinguish the Rogers & Hamilton from the other Rogers brands in the market. They are the originators of the idea of packing large pieces of flat ware and combination sets in satin-lined cases without extra charge, an innovation which retail dealers were not slow in appreciating. Their goods are all hand-burnished, and they claim that each line is the best of its class. The Rogers & Hamilton and Crown Hamilton brands are claimed to be superior to any other brands of flat ware, in design, workmanship and durability. All the Rogers & Hamilton goods are warranted in every respect.

—The city of Meriden, Conn., "out-Heroded Herod" on the occasion of the visit of the American International Congress Oct. 10. Twenty-eight of the leading manufacturers made a brilliant display of their productions at the Opera House, and thoroughly roused the admiration of the visitors by the excellence and artistic quality of silverware, cutlery, etc. Among the concerns represented kindred to the jewelry trade were the Meriden Britannia Co., the Bradley & Hubbard Mfg. Co., the Wilcox Silver Plate Co., the Meriden Silver Plate Co., Edward Miller & Co., the Manning & Bowman Co., C. Rogers & Bros., Meriden Cutlery Co., Charles Parker Co., and E. J. Doolittle. The exhibition was attended by all the prominent people of the city. The congress made a tour of the immense factories of the Meriden Britannia Co. and the Bradley & Hubbard Mfg. Co. The New York *Tribune* in its telegraphic account of the event, spoke in compliment of a catalogue in Spanish prepared by the Meriden Britannia Company. George E. Savage and Frank W. Thomas had charge of the Britannia Company's exhibit, and the company's committee at the factory to entertain the visitors were Geo. R. Curtis, Geo. H. Wilcox, Geo. M. Curtis, John Jepson, E. E. West, Pedro Almeida, W. W. Wyatt and Alfred Watts. The windows, etc., were gayly decorated with flags and bunting. Several, among them The Meriden Silver Plate Company, enhanced the beauty of their exhibits by arrays of flowers. Altogether, a notable day in Meriden. The town has the honor of having been the only city in the State to place before the South Americans an exhibit of its industries.

—The firm of Wm. C. Edge & Sons, Newark, N. J., has been incorporated under the title of the W. C. Edge Co., with a capital stock of \$100,000.

—The publication of that interesting little magazine, "The Connoisseur" was discontinued with the September number, by its publishers, Bailey, Banks & Biddle, Philadelphia.

—Lawson & Van Winkle, 11 Maiden Lane, are making a specialty of bonnet pins, in moonstones, pearls, turquoises, diamonds, sapphires, rubies, opals, onyx, hematite and imitation pearls. Their line of enameled flowers is very complete.

—T. B. Bynner, 177 Broadway, New York, has manufactured for the fall trade a large stock of rich diamond, pearl and opal jewelry in original, and we think, very salable patterns. His stock of rolled, plated jewelry is also very large and well selected.

—As the season for emblems, charms, etc., is now at its height, we desire to call the attention of our readers to the stock of J. W. Richardson & Co., 196 Broadway, New York. An illustrated catalogue can be obtained from your jobber containing the manufactures of this house.

—J. B. Wood of Charles F. Wood, 171 Broadway, New York, is now in Europe among the marts of diamonds and precious stones, and the firm will receive from time to time, until the 1st of December, large lines of diamonds and fancy colored stones to which the attention of the trade is directed.

—E. & J. Schweikert the tool and material dealers, Cincinnati, Ohio, have employed one of the finest workmen in the country, and in the future will make a specialty of repairing chronometers and fine complicated watches. This firm's success is quite remarkable, though not more than they deserve.

—H. M. Smith & Co., 83 Nassau street, New York, when visited were found to be very busy. While there is a steady demand throughout the year for their Paul E. Wirt fountain pen, there is especial activity, at this season of the year, in this as well as in other lines of their stock of their own manufacture, and American watches.

—The Hartford Silver Plate Co., Hartford, Conn., take time by the forelock. They are not only now in the market with many new and tasteful goods, in fact, the largest they have ever offered to the trade, but their designers are busy preparing new designs to be brought out next season. Their shop has for weeks been running twelve and a half hours per day to keep pace with demand for their goods.

—Cattelle & Decker, 20 Maiden Lane, New York, are quite busy making the many novelties in oxydized silver in which line of business they have taken a leading position. They have also introduced a new line of silver goods, which they have very happily named "The Brilliant," as these goods are made of virgin silver. This firm are also importers of diamonds and handle a large line of rich jewelry.

—Among the articles outside the usual class, that are especially suitable as holiday presents this year, are artistic clocks, lamps, pedestals and tables. Perhaps as excellent and extensive an assortment of these goods both in respect to elegance of design and fineness of structure, as may be found in the city is that in beautiful Mexican onyx, displayed at S. Klaber & Co's. centrally located showrooms, 47 West 42nd street, New York.

—The Cincinnati wholesale jewelers formally organized their local branch of the National Wholesale Jewelers' Protective Association at Cincinnati on October 12th, and report a very large attendance. With one exception all the wholesale jewelers of the city attended the meeting and signed the constitution and by-laws. They elected as members of the National Executive Committee Messrs. A. G. Schwab and A. Herman. The preamble and principles of the constitution were heartily endorsed by the jobbers of that city.

—Bowman & Musser, Lancaster, Pa., have taken the building adjoining their former store, torn down the partition walls and incorporated the two buildings into one, and built a large addition to the united building, which they occupy throughout. An entire new front has been put in, a massive vault, three stories high, for storage of surplus tools and materials, has been built, and every modern convenience in the way of office equipment has been put in. The increased space is *three times* the former space. Their business has shown a very large increase in the past year (over 42 per cent on some months), necessitating the employment of eight more clerks than they had last year. Their three travelers are on the road constantly.

—Oskamp, Nolting & Co., Cincinnati, O., believe that the only way to do a large business in diamonds and precious stones, is to have the assortment, and they have acted on their belief, for a larger assortment of tasty, mounted goods than theirs, it would be difficult to find. The firm is always willing to send dealers selection packages, and a telegram is sure to catch them. All who have not seen their diamond albums, should send a postal card, when they will receive one by return mail. Mr. Oskamp, purchases all the diamonds Oskamp, Nolting & Co., carry in stock direct from the cutters in Amsterdam, a fact that no buyer ought to forget.

—C. B. Wilkinson, manufacturer of badges and medals, 42 John street, has just made for a New York Masonic Lodge, to be presented to district deputy grand master William Gibson, jr., a remarkably fine badge in green and red gold, enriched with diamonds and precious stones. The pin portion from which depends a tessellated curtain, is marked by an enameled eye from which emanate rays in all directions. Below this is an enameled bar bearing the words "Grand Master." The pendant is surmounted by two cornucopias in red gold from each of which bursts a leafy branch dotted with pearls. Encircling the pendant is the customary wreath of green gold, while in the centre are the familiar symbols, the quadrant, the square and the compass, the whole embellished with three large diamonds set in triangular shape.

—The new refining process for watch and clock oils, invented and in use by William F. Nye, the well-known manufacturer of New Bedford, Mass., has proven so successful during the past two winters, that he intends this season to work a very large quantity, and to that end is now engaged in preparing an extensive amount of crude oil, which will be shipped shortly to his Canadian refinery. Mr. Nye has still further improved the process and this year will see on the market the finest lot of oils that he has ever produced. Watchmakers should appreciate these efforts to produce an absolutely reliable oil, and encourage the manufacturer by giving the new article a trial. An idea of the popularity of Mr. Nye's watch and clock oil, will be conceived when it is stated that his yearly sales amount to 3,000 gross bottles together with a quantity equalling two-thirds of this amount which is sold in bulk to the watch factories.

—The Julius King Optical Co., on account of the increasing popularity and demand for their specialties in the Far West, have found it necessary to establish a general agency for the sale of their optical goods on the Pacific coast. This agency has been given to Messrs. Nordman Bros., of San Francisco, who are recognized as the leading and most popular jobbing house in this line on the Pacific Slope. The Julius King Optical Co., with their main office and head quarters at Cleveland, O., their right wing at 4 Maiden Lane, New York, under the efficient management of Mr. Leo Wormser, and their left in the control of Messrs. Nordman Bros., will now be able to look after the wants of the optical trade of the whole country. It is the earnest endeavor of this company to elevate the standard of the optical business, and with this end in view a course of instruction has been prepared whereby jewelers and opticians can have an opportunity to better qualify themselves to do satisfactory work in their optical department. The lecture course has special reference to the use of Trial Lenses and the methods and tests used in fitting eyes. No traveling opticians are allowed the privilege of the instructions; it being intended only for regular established jewelers and opticians, and for but one dealer in each place.

—The jury for the Horological Section of the Paris Exposition, awarded to the Usine Genevoise de Dégrossissage d'Or, Geneva, Switzerland, a silver medal for their Anti-Magnetic metals with which they make their anti-magnetic compensation balances and hair springs, and for which they have had patents granted in the United States, Canada, England, France, Germany, Switzerland, Italy, Spain, Brazil, the Argentine Republic and Austria-Hungary, except in Germany for their hair-springs. They have had another patent granted in the United States for their anti-magnetic compensation Balance Chromine, dated 28th May, 1889, No. 404,220. They claim that the composition of their balances and hair-springs contains no alloy infringing on any other patent granted in the United States, Canada, and all other countries where their balances and hair-springs are patented, and therefore that they cannot meet with any opposition in the said countries concerning the working of their patents. For watch movements provided with a steel and brass compensation balance they recommend their anti-magnetic hair-springs "Mangor" which possess the same elasticity as the best steel hair-springs, and are entirely insensible to humidity and moderate acids.

—Illustrations are given on another page of the "Cherub Key," a recent product of that well-known and reliable firm of watch key makers, Kendrick & Davis, Lebanon, N. H.

—Champenois & Co., 5 Maiden Lane, are pushed to supply the demand for their well-known white stone goods and bright polished work, of which they offer an unusually large variety of patterns.

—A special feature in the extensive stock of Cross & Beguelin, 21 Maiden Lane, New York, this season, is a large line of mounted goods in every class of jewelry and in a great variety of designs.

—Jewelers throughout the country will now receive requests for designs suitable for class rings and medals for excellence in the different branches of scholarship. E. R. Stockwell, "The Badge Maker," of 19 John street, can always furnish something new in this line.

—The demand for the "Shakespeare Bangle," manufactured by Frank H. La Pierre, 18 E. 14th street, still continues unabated. A wider bangle of the same style has just been placed on the market, as well as a "Shakespeare ring," resembling the popular snake ring in construction.

—C. L. Viets, Augusta, Kans., offers \$200 reward for the arrest and conviction of the burglars who robbed his safe on the night of Oct. 14. The robbery included all of the valuable portion of the stock, but he telegraphed at once for new goods, and is ready to serve the public as before.

—Jacot & Sons' window, in their store at No. 298, is now one of the sights of Broadway. Crowds of people during the business hours of the day gaze delightedly at the many musical novelties therein displayed. Messrs. Jacots' store is undoubtedly headquarters for everything in the line of musical boxes, etc., etc.

—Adolph Aderer, for years past connected with S. Amberg & Co., Cincinnati, Ohio, as traveling salesman and formerly book-keeper, has severed his connection with that house, and will shortly start for New York, where he will open in the wholesale jewelry business in partnership with F. Jelenka, an Eastern young business man.

—The improvement in gold pen manufacture, patented recently by Aikin, Lambert & Co., 21 Maiden Lane, New York, and described in the October CIRCULAR, has proved so successful that it is being gradually introduced in all pens manufactured by this house. This is one of a very few radical changes in pens that has been effected in twenty years.

—Fowler Bros., 198 Broadway, are offering to the fine retail trade over one hundred new patterns of sterling silver bon-bon boxes, perhaps the largest assortment of this popular little novelty to be found in the market to-day. The designs are all unique and executed in the superior style that has won such hearty and speedy recognition for the sterling silver goods of this house.

—Herbert B. Miller, son of Isaac M. Miller, of Miller Bros., carried off first prize as an amateur in photography at the New Jersey State Fair, recently closed. Among the competitors were numbered several professionals, besides amateurs, and the young man's ability must have been of a high order to warrant the prize. A sample of his work, submitted to the writer, showed art, equaling that of many a professional Broadway photographer of established reputation.

—A feature of the stock of Mathey Bros., Mathez & Co., 16 Maiden Lane, New York, is a complete line of fine ladies' watches in beautiful cases, jeweled, chased and plain. Their regular stock of fine complicated watches—chronographs, split seconds and repeaters—is extensive, and a steady business is being done in them, an unusual state at this season of the year. The patent double-watch barrel described in our last issue, is being gradually introduced in the products of their factories. The device saves considerable cost of making, and makes the watch less complicated, though the same results are produced.

—S. F. Merritt, Springfield, Mass., has a new line of old silver oxidized eye glass holders and chains which are meeting with astonishing success. They are very showy and attractive in appearance. His sterling goods are also selling with great rapidity. So great has been the increase in his business that he has been obliged to double his force and add new machinery. He is making arrangements to present his goods to the European public, where their excellence and cheapness will doubtless ensure for them a sure and speedy popularity. Mr. Merritt says that his recent advertising in the CIRCULAR has been more beneficial to him than all he ever did before.

—Never has the stock of imported clocks, bronzes, etc., at the establishment of Charles Jacques, 2 Maiden Lane, New York, appeared so complete and beautiful. Shipments of new designs are constantly coming in, one of 400 marble and onyx clocks having just been received. While the goods carried by Mr. Jacques are of unusual excellence, as regards design and execution, the low prices at which they are listed, render them very salable articles.

—The tri-announcement of Stern & Stern, 13 Maiden Lane, on page 31, will prove of special interest to dealers. The first invites visitors to New York to make their headquarters at their offices, which are most conveniently located, respecting the jewelry trade, are spacious and particularly adapted to that purpose; the second is a representation of their handsome business card, showing that they carry a varied stock of goods; and the third, that they have prepared for this season, most complete lines comprising numerous new and beautiful designs in diamond jewelry—exclusively their own—and including novel patterns in their "Eclipse" watch cases, which have become well-known and popular in the trade.

—Most of the readers of the CIRCULAR are familiar with the name of the "Rochester Lamp," but few of them perhaps are aware of its special fitness in its latest and most artistic styles to find a place in the stock of the retail jeweler. The manufacturers, Edward Miller & Co., 38 Pearl street, Boston, Mass., and 10 and 12 College Place, New York, have now ready for the holiday trade a very large assortment of these celebrated lamps mounted in the most elegant manner. Piano, banquet and vase lamps are displayed at their show rooms in oxidized silver, antique brass and with delicate hand-painted decorations. Another point:—The "Rochester," with its broad effulgence, is a very useful thing to hang in a jewelry store for illuminating purposes, as it greatly augments the brilliancy of the evening display.

—The following is quoted from the *Hadikat-el-Akhbar*, a weekly newspaper of Beyrouth, Syria, Asia: "Mr. E. Bissinger, Consul of the United States of America, at Beyrouth, has occupied himself since his arrival in Syria in establishing direct commercial relations between his country and ours. We understand with satisfaction that the disinterested efforts of Mr. Bissinger, on which he ought to be congratulated, are about to be crowned with success. American manufacturers of silk stuffs have already communicated with the Consulate of the United States in this city, asking for information concerning the direct importation of the raw silk of Syria, which is our most important domestic product, and to which Mr. Bissinger has devoted much study and attention." Mr. Bissinger is a brother of Philip Bissinger, and was formerly in the jewelry trade of New York.

—Prominent among the beautiful novelties of the season are the gold bonbonnières that the S. Cottle Co., 860 Broadway, New York, placed upon the market last month. For beauty and elegance of finish, seldom has such a line been seen. Exquisitely chased with various floral designs, or in plain Roman gold or red satin or polished, they are a charming novelty to the jeweler's stock. They are made in all these styles, in seven sizes and in various patterns, some being ribbed and others being gemmed with diamonds, turquoises, etc. Though these trinkets have been on the market scarcely a month, hundreds have been sold, and as much factory facilities as can be spared are being rushed to fill the numerous orders that are constantly coming in. Another line of goods of this company that is having heavy demands made upon it, is their one-piece button, made in all styles and designs. Perhaps never in its history has it commanded such an extensive sale.

—Lights are to be seen in the factory of the Alvin Mfg. Co., 24 Boudinot street, Newark, N. J., until far into the evening. Notwithstanding the fact that they have largely increased their facilities, put in new machinery, and are now employing about 65 hands, overtime is still necessary. They are showing many new examples of their beautiful "Alvin Ornamentation," a process of electro depositing silver on crystal glass, of which the concern makes a specialty. This rich and brilliant effect is conspicuous in scent bottles, colognes, claret jugs and fine stationery novelties. They have also added many new shapes and styles to their line of cane and umbrella heads, deposited on ivory, tortoise shell, pearl and fancy woods. Among these we may mention a quaint conceit in the form of an old shoe in oxidized silver, with the big toe of the foot protruding and the ankle above covered with an old-fashioned worsted stocking forming the stock of the handle. Engraved on the stock appears the following well-known quotation from Shakespeare, somewhat perverted to suit the application: "There's a divinity that shapes our ends rough—hew them how we will."

—Buyers of fancy goods and jewelers' art novelties should take advantage of the extraordinary bargains offered by the C. D. Pratt Co., 33 Chambers street, who are selling off their stock preparatory to retiring from business.

—Lewis Bros., 41 Maiden Lane, are making a great variety of sterling silver novelties, a list of which will be found on another page. Their goods have won a reputation for finish and originality of design second to none.

—The Jewelers' Mercantile Agency, limited, has begun suit in the Chicago courts for \$50,000 damages against R. G. Dun, Erastus Wiman and Arthur J. King, composing R. G. Dun & Co.; Robert D. Douglas, Henry G. Smith, Benjamin Douglas, William A. Douglas, Charles A. Morgan, James R. D. Graham, Joseph H. Lobell and George H. Crawford, all of whom are employes of Dun & Co. It is alleged that the Dun's agency inspired a libelous and defamatory article in a Chicago paper which has injured the plaintiff's standing.

Skillman, Vanderveer & Williams, the well-known bracelet manufacturers of Trenton, N. J., successors to the old firm of Deutz & Co., have recently moved from Deutzville to a more convenient location in the city proper, at No. 131 North Greene street. The "Trenton bracelets," of which they make a specialty, have maintained a first-class reputation these twenty years for quality and style. They make in both 14 kt and 10 kt., band, wire, padlocks, chain and novelty bracelets, and, in addition, a line of 14 k. gold stiffened bracelets.

—The "John Foley Gold Pen" has a wide-spread reputation all over the country for its high standard of excellence. For over forty years John Foley has been engaged in the manufacture of gold pens and pencils, and as other pens bearing the name of Foley have been put upon the market recently, he wishes to inform the trade that the original and genuine Foley pen can only be obtained from his sales-room, 306 Broadway. He has just decided upon an important reduction in prices, making these fine goods lower than at any time in the past 40 years.

—English chiming clocks are a magnificent feature of the best class of manufactures offered this season. At the showrooms of D. Valentine, 3 Maiden Lane, New York, are displayed a number of these elegant timepieces that have just been received from the other side. The movements are cased in tall cases, 8 ft. high, elegantly designed in mahogany, rosewood and oak. The clocks chime the quarter hours either on eight westminster or four gongs, as desired, and strike the hour in an extra heavy-toned gong. A beautiful line of mantles with same movements, but small cases, is also shown.

—The reader will find considerable to interest him in the beautiful pages of the Towle Manufacturing Co. in another portion of this issue. With the well-known policy of this company to constantly produce new goods, that will prove of advantage for dealers to handle, they offer this season three new patterns that need but casual examination to uphold the company's established reputation for fine workmanship. The beautiful "Diana" is designed to meet especially the growing demand for ware combining high art with substantial weight. The "Argyll" and "Scroll," hand-engraved patterns in new and delicate designs are additions to the company's already superior line of engraved ware.

—We call attention to the new and beautiful design for forks and spoons, the "Flora," made by Geo. W. Shiebler, 8 Liberty Place, N. Y., and illustrated in this issue. The success attending the "Flora Tears," which elicited letters of praise from all parts of the country, encouraged the manufacturers to produce the set of flatware in its entirety. Each size of handle presents a different flower, exquisitely moulded and in bold relief—the complete set forming a lovely collection of most artistic ware for table use. We are confident that there is no handsomer design offered to the trade. A full line of fancy pieces also is manufactured in the same style. Each design of the "Flora" (eighteen in all) is protected by patent. The "Flora" is made only in sterling ware.

—Henry C. Haskell, 11 John street, Corbin Building, New York, is the recipient of the following letter: "The 'Razzle Dazzle' Puzzle Rings won't work with us. We get them 'loose' and that settles it. Not a man in Georgia could ever get them in shape again. All the family would go crazy over them except the mother-in-law; she is too busy with the son-in-law's other affairs to stop one moment on *puzzles* of any kind. This may be far fetched, but it is from Home, Sweet Home. Please give me credit for the amount on your books, and I will try other goods instead." A dealer in Kansas writes: "I have calls for your 'Razzle Dazzle Puzzle Rings.' Mr. Haskell is daily receiving orders for these rings, which are increasing in popularity from Maine to California.

Fred. I. Marcy & Co., have a novelty in their "Eiffel" collar button that promises to rival their celebrated "Acme" sleeve button. The button is backed with enamel, which prevents discoloration of the metal as well as poisoning of the neck.

—Extremely artistic novelties in the way of jewelry boxes are those just placed upon the market by the American Morocco Case Co., of 7 Bond street, New York. They are made of white metal silver plated; are designed in three different styles, plain satin finish, rococo or 14th century, and oriental, and are gotten up to be especially adapted for watches, queen chains and diamond jewelry, such as rings, studs, brooches, sleeve buttons, bangles, etc. The knobs of the clasps are of mother-of-pearl, and in the center of some of the cases is a small blank space in the shape of a scroll, etc., where the owner's name may be engraved. Altogether, these cases form a decided and handsome novelty, worthy the consideration of all dealers. On another page one of them is illustrated. The reader will readily note its beauty. The trade mark of the company, "A. M. C. Co., N. Y.," is stamped on each box.

—The visitor calling at Miller Bros.' sumptuous offices at 37 Union Square, N. Y., may inspect one of the most extensive lines of gold jewelry consisting of lace pins, brooches, lockets, scarf pins, medallions, hairpins, sleeve buttons, and links, studs, collar buttons, bangles, etc., that is produced in America, completed with new designs for the season. The constant demand for their well-known initial goods, necessitates carrying at all times a large stock from which a dealer can make a choice selection. Business for years, we are told, has not been so active as it has been this season. James W. Hagan, in the interest of the firm, is on the Pacific slope on a four months' tour doing a most satisfactory business; Mr. Jackson has just returned from an unusually successful trip to New Orleans; L. H. Smith, just home from the West, has gone East, and Lewis H. Miller is returned from a prosperous trip through Pennsylvania.

—The spacious showrooms of Taylor & Brother, at 860 Broadway, New York, are replete with beautiful goods specially selected for the fall holiday season. The uniqueness and beauty of design discovered on all sides, rouses in the visitor a constant feeling of surprise and admiration. On entering, one of the first things to be noticed is a large vase standing almost three feet high, of sarreguemines ware, after the Egyptian style. Further on are French faience pieces with thistle design and real gilt ornamentations, French china vases revolving at the bases, lamps and vases combined on handsome bronze stands, Mexican onyx clocks—a large line—newly modelled, a line of California onyx clocks, of a bright color, delicate bronze and onyx clock sets, prettily decorated porcelain clocks, of varied shape and design, magnificent English chiming clocks, Turkish blue marble clocks—entirely new—with gilt mountings, and an unusual variety of small wares, bric-a-brac, bronzes, etc.

—We print on the entire page, No. 9, an advertisement of the Spencer Optical Mfg. Co., No. 15 Maiden Lane, which should be read with interest by all dealers in optical goods. We refer specially to that part which begins:—"At no time in the history of this country, etc.," in which they give a number of reasons why optical dealers and opticians should keep in stock a set of Audemair's Test Lenses, both to facilitate their own business and do their duty by the public. Few people are aware of the great injury liable to result from wearing glasses that are not properly fitted. The Spencer Company believe that the secret of this seeming neglect on the part of the public is becoming more generally known, and that the responsibility is being placed where it belongs,—on the improperly equipped optician. They are, therefore, of the opinion that those who find it necessary to wear glasses will consult their own interests by seeking the aid of such opticians as are provided with a complete set of Audemair's Test Lenses.

—The almost phenomenally large sale of the well-known one-piece collar button manufactured by Krementz & Co., perhaps justifies the assertion that "the collar button and the ring are the only absolute necessities in jewelry manufacture." The facilities at the factory for manufacturing this article have been doubled to keep pace with the vastly increased demand, which, it is said, has also been doubled within the past six months. The proportion of men and boys in the United States to the total population (60,000,000), being estimated at about one to four, makes 12,000,000 persons who must wear collar buttons of some sort. It is the object of Krementz & Co. to supply these 12,000,000 persons with one piece buttons—a high ambition forsooth, but considering the enormous quantities of these goods carried in stock, the fact that they are made in gold and rolled plate, and the excessive demand, it is not wholly unreasonable to suppose that we will all be using one-piece collar buttons at some near future day.

—The Essex Watch Case Co., Newark, N. J., are so rushed with orders that they are obliged to run until 9 o'clock every evening, paying for the steam power of the entire building after regular working hours. There is probably no filled case factory in the country that takes as much pains with its goods as the Essex does. Every detail is under the personal supervision of T. B. Hagstoz, whose experience in the manufacture of filled cases dates back more than twenty years. As a result of this long experience a number of improvements on the ordinary processes of manufacture have been adopted. The rolls used to prepare the stock are the heaviest employed in any factory in the country. After passing through the springer's hands every case is returned on a solid steel model of the movement it is intended to fit. Another interesting feature is an elaborate system of record of work in hand, insuring the prompt delivery of goods as promised, for the superintendent has but to glance at this record upon inquiry from any customer to tell just what stage of completion the goods wanted have reached at that time. The company makes three grades of goods, the "Essex," the trade mark of which appears in their advertisement on another page, a full 14 kt. case, heaviest plate, guaranteed for 25 years; the "Columbia," guaranteed for 20 years, and distinguished by a shield for a trade mark; and the "Derby," a cheaper case, made under the Evans' patent in open face. In introducing a price list, just issued, the company make the astonishing statement that they have manufactured over 60,000 cases, which are now in use, and *not one of which has ever been returned* to them on account of imperfect wear or finish.

—Everybody is familiar with the name of Rogers & Bro., Waterbury, Conn., and 16 Cortland street, New York, because of their old standing and high reputation as manufacturers of fine grades of silver-plated table ware. For almost half a century the name has been a guarantee of excellence, and their goods are a standard for all silver-plated flat ware. In 1847, three Rogers Brothers formed a partnership to manufacture silver-plated ware at Hartford, Conn., and eleven years later two of the brothers, Asa H. and Simeon S., removed to Waterbury and established a business under the firm name of Rogers & Brother, adopting the trade mark of "Rogers & Bro. AT." They began the manufacture of rolled sheet nickel silver metal spoons, forks, knives and other articles of flat tableware in greater variety of design and on a more extended scale than had ever before been attempted in this country. The goods were so superior in quality and design that a large demand was created for them at once, and the foreign goods which up to that time had held first place were driven entirely out of the market. The rapid growth of the business making an increase of capital necessary, the firm was incorporated without change of name or trade mark, the two brothers holding a controlling interest in the new company. Since this time (1859) the two original founders have died, but the business has been continued in the same enterprising and successful manner which characterized its early history. The company to-day, with the advantages of modern improvements and long experience, are manufacturing a finer line of goods both in quality and design than ever before, a full assortment of which can be seen at their New York store, No 16 Cortland street.

—Among the signal victories obtained at the Paris Exposition were those gained by two watches especially well known in the American market. We refer to the Longines and Agassiz. The popular and well-reputed Longines' watches attained more than an ordinary success in receiving the grand prize. The Longines watches are too well known throughout the world to need much further comment. Notwithstanding increased facilities, the factory is behind on orders and will be obliged to enlarge to meet the growing demand. Not only in low-priced articles has this singular success been achieved, but in the better grade as well. They have been proved to be remarkably accurate timekeepers by the fact that when exhibited at the observatory of Kew, England, they have always come out with first-class certificates. For these reasons these goods are recommended to a class of people such as engineers, etc., who require a first-class timekeeper at a reasonable price. It is hardly necessary to state that these movements fit all standard cases. Taking into consideration that the first Agassiz movement was made in 1876, the successful career of this manufactory stands self-proven. The performance of the movements has surpassed that of well-known and old makes, although they are considerably cheaper in price. At the observatories of Geneva and Neuchatel, where heretofore only high-priced movements received first-class ratings, the Agassiz movements of medium price came at once to the front, to the great astonishment of the famous astronomers in charge. Besides manufacturing a complete line of ladies' and gents' movements of three qualities, Mr. Agassiz has given his attention to the manufacture

of complicated watches, such as split seconds and minute repeaters, which have become very popular on account of their accurate and reliable construction, retaining all the qualities desired in such watches, although sold at a very reasonable figure.

Among the Watch and Clock Companies.

- The Elgin factory is turning out 1,650 watches daily.
- The pay roll of the Dueber-Hampden works numbers 1,820 hands.
- There were 2,737 names on the Waltham factory's pay roll October 1st.
- The daily output of the watch factories in America is at present estimated to be 6,000.
- Hon. Stephen A. Douglas, Jr., of Chicago, Ill., was a visitor at the Dueber factories on Oct. 11.
- The output of the American Watch factory is claimed at present to be considerably over 1,500 per diem.
- Charles D. Rood, President of the Hampden Watch Co., is the proud father of a bouncing eleven-pound boy.
- The Baraboo (Wis.) watch factory scheme, originated by Jos. Hurd, late of the Rockford factory, is said to have fallen through.
- The Dueber Watch Case Mfg. Co. are considering propositions from three different watch companies to purchase their entire plants.
- If the world's fair of '92 is held at Chicago it is suggested that the Elgin Co. establish a regular factory there, showing all departments of work.

The Trenton Watch Co. received an "Honorable Mention" at the Paris Exposition for the excellence their watches, quality and price considered.

—The American Industrial Congress will visit the Illinois Watch factory at Springfield, Ill., to form their ideas of the manufacture of watches in Illinois.

—It is the purpose of the Elgin Watch Co. to utilize water gas under the furnaces and in all the various compound blow pipes throughout their factory.

—The Illinois Watch Co. have now thoroughly introduced their watches in England. Alexander Bros., Ltd, 16 Hatton Garden, London, are their general agents.

—The Seth Thomas Clock Co. have issued a supplement to Catalogue No. 453, of new designs in imported marble, enameled wood (imitation marble), onyx and fancy clocks.

—The project of founding the Non-Electric Watch Co., at Dubuque, Ia., is still in motion. A representative of the new company will shortly visit the city for the purpose of selecting a site for a factory.

—The watch department of the Seth Thomas Clock Co., is doing a steadily good trade. The first lots of the new "Henry Molineux" watches have been received from the factory and orders of moderate size can be filled.

—General business with the Seth Thomas Clock Co. is at present very brisk. Especially is this so from the South, business from that section of the country being better than it has been for a number of years, during this season.

—Since the Trenton Watch Co. closed out the large lot of their movements in Dueber silverine cases, jobbers who were fortunate enough in securing a part of them have been doing an active business in this popular watch.

—October 5th marked a red letter day in the Hampden works, for on that day five hundred and thirty-four complete watches were turned out, 70 per cent. of which being 15 jewel grades of the various styles made by the company.

—The Hampden watch factory is running till 9:30 P. M. each night. It is behind in orders for the company's higher grades. The large demand for these higher class watches this season is a noticeable feature of the Dueber-Hampden business.

—The United States Watch Co., Waltham, Mass., are negotiating with the city of Waltham for the acquisition of about two additional acres of city land, and if they acquire it they will have one of the finest watch factory properties in the country, embracing, as it will, fully five acres or one entire block. If the negotiations succeed,

the company next spring proposes to more than double the present building capacity, and to treble the output, which is now about 100 watches a day.

—John C. Dueber last month went to Lexington, Ky., to examine a \$2,500 mare to match his Kentucky thoroughbred, "Duke."

—The craze for starting watch factories seems to be on the increase, but most of the enterprises are but prospective, some being not even that. The expense incurred in establishing a plant to turn out watches, which, after all, may prove unmarketable, is enormous, and projectors should thoroughly fathom the matter before laying out the first plan.

—The new nickel and 14 size movements that the Illinois Watch Co. placed upon the market last July and August have proved very popular, numerous orders for them being constantly received. Both these movements are seven-jeweled, the former being the only 6 size so jeweled offered to jobbers. The company are increasing their product with only a moderate increase of employees.

—The various rumors to the effect that the old Dueber buildings at Newport, Ky., are to be occupied as watch or watch case factories have no foundation; in fact, the buildings are still for sale, and no applications from such factories are on file, though several communications have been received from parties who wish to start cotton works.

—The Russell & Jones Clock Co., of Pittsfield, Mass., are manufacturing a large line of staple clocks for the jobbing trade in walnut, nickel and marble finished wood in great variety of styles. They have lately added to their factory facilities and put in new machinery to meet the demand of their constantly increasing trade. They are preparing to place upon the market a full assortment of new styles in their various lines of manufacture.

—The New York Standard Watch Co. have just introduced a new nickel damaskeen movement which has been pronounced by numerous practical watchmakers to be the best movement in America for the money, \$3.50. The factory of the company is running to its full capacity, and has been doing so right along, notwithstanding reports to the contrary in trade and watch town local journals. The output is by no means equalling the demand.

—The Aurora factory difficulty is still subject to spasmodic stir-ups, but very little progress is made towards the proper adjustment of the matter. A few of the stockholders seem to question the policy of assignee Evans, and are hanging back for more than fifty cents on the dollar. The matter will evidently have to come to a settlement very soon. The opinion of numerous sound business men in the trade is that the plant is too valuable to go out of existence.

—The "Century" screw bezel watch case recently introduced by the American Waltham Watch Co., has proved successful and is commanding a large business. This case is made on the same principle as the double stock Bond Street cases which are so well known to the trade. The pendant and bow are of solid coin silver, and the body of the case and glass bezel are made of double stock, composed of coin silver and nickel, one-third silver. The combination makes a watch case that has the wearing qualities of a solid silver case, and being dust-proof, affords perfect protection to the movement.

—The American International Congress visited Waltham, Mass., Oct. 5, and was accorded a hearty reception by the town, which made the occasion quite a holiday. The principal reason of their visit was to inspect the American watch factory. The Crescent band struck up a Spanish air upon their arrival there, and the party, under the guidance of Royal E. Robbins, Jr., were conducted to the business offices, where a collation was spread, and afterwards, accompanied by Congressman Banks, were taken through the factory and shown how American watches are made. The factory was decorated with bunting and flowers, and in the jewelers' room \$40,000 worth of jewels, rough and finished, and crystal watches made one display.

—Orders for the large clocks of the Seth Thomas Clock Co. are plentiful and steady. The company have recently furnished a large clock to the St. James Church, at Haverhill, Mass., which strikes the hours and angelus; one for the Congressional Church at Alfred, Me.; one with 1000 lb. bell, striking hours and half hours, dial being 7 ft. 3 in. in diameter, for Deaf, Dumb and Blind Asylum at San Francisco, Cal.; one to City Town, Ga., dial, 5 ft. 6 in, striking hours and half hours; one for the high school at Portland, Me.; one for the hotel at St. Rockingham, N. C., and the company is filling a contract for a large timepiece for the new Union Pacific Depot at Cheyenne, Wy., which has glass dials 6 ft. 6 in. in diameter.

—Wm. H. Atwater, whose name for years has been inseparably connected with the E. N. Welch Mfg. Co., has accepted the sole agency for the Boston Clock Co., of Boston, Mass., retaining however, the agency of the E. N. Welch Mfg. Co. He has displayed at his salesrooms, at 6 Warren street, a complete line of the "Boston" clocks, in handsome onyx, marble and fire gilt cases, the fronts, backs and sides of the latter being of bevelled glass. All the products of the Boston Clock Co. are covered by letters patent. The following are among the prominent features in their manufacture: all the movements are eight-day, jeweled, and fitted with a fine watch escapement; will run correctly in any position; are noiseless in ticking; the mantel movements are made to fit openings in cases $4\frac{1}{4}$, $4\frac{3}{4}$ and $5\frac{1}{4}$ inches in diameter; they have French sashes with bevelled glasses and back sashes with adjustable straps and screws for fastening the movements in cases; the dials are in various elegant designs of porcelain. These features, combined with others, substantiate the claim that the clocks are among the best made. A handsome catalogue of the E. N. Welch Mfg. Co. for 1889-90 has been issued, showing numerous new designs in marble, wood and iron mantel clocks; also in regulators and novelties. A special feature of their make is a new and complete line of highly polished black enameled wood mantel clocks, corresponding in style and appearance to the imported French clocks, though at very much less cost.

The Waterbury Watch as a Chronometer.

The account of the voyage of the schooner *Norway*, and the navigating of the vessel by aid of a Waterbury watch, contained in the September issue of the *Waterbury*, was editorially commented upon by several daily papers, one of which an Ansonia (Conn.) journal, doubts the veracity of the story. Immediately upon the appearance of the doubting article, the company wrote the Navy Department as follows:

92 & 94 LIBERTY STREET, NEW YORK, Sept. 27th, 1889.

HON. B. F. TRACY,
Secretary Navy, U. S. A.,
Washington, D. C.

DEAR SIR—Not knowing the special branch of your department to which application should be made for information desired, we are compelled to go to headquarters and beg you to refer this to the proper party. To be brief, we enclose a newspaper clipping, taken, we believe, from the Ansonia (Conn.) *Herald or Sentinel*, and relating to a communication alleged to have been received by the Navy Department from Lt. Stockton.

Is there any truth in the printed statement, and, if so, can we obtain a copy of that portion of Lt. Stockton's letter.

Perhaps this may seem very trivial in comparison to the affairs of a nation, but then nations are simply aggregations of individuals, and we trust that American citizens may be pardoned an occasional intrusion.

To us it is a matter of interest, and we shall appreciate any reply that can give us any light in regard to its truth.

Believe us very truly,

THE WATERBURY WATCH CO.

And received the following in reply:

In reply refer to 6407.
E. C. B.

NAVY DEPARTMENT,
BUREAU OF EQUIPMENT AND RECRUITING,
WASHINGTON, Oct. 2d, '89.

GENTLEMEN—In reply to your letter of September 27th, 1889, to the Secretary of the Navy, asking if there is any truth in a certain printed statement relative to the use of a Waterbury watch for navigating purposes on the schooner *Norway*, I have to inform you that Lieutenant Commander C. H. Stockton, U. S. N., commanding the U. S. S. *Thetis*, made an official report under date July 13, 1889, from Port Clarence, Alaska, from which the following is quoted:

"I beg to report to the Bureau that upon my arrival at this place on the 11th inst. I found the schooner *Norway*, Winslow, Master, Ensign W. L. Howard, U. S. N., being head of the party which it carried.

"Mr. Howard stated to me that the schooner was without proper means of navigation, the only chronometer belonging to the schooner being out of order; and the only means of obtaining longitude being a 'Waterbury Watch,' by which they had succeeded in reaching Port Clarence. Under these circumstances I felt justified in loaning the *Norway* the hack chronometer of this ship, taking Mr. Howard's receipt in duplicate, one of which is hereby enclosed."

Very respectfully, GEO. DEWEY Chief of Bureau.

THE WATERBURY WATCH CO.,
92 & 94 Liberty St., New York City.

G. E. Y.

The popularity of miniature brooches is apparently still in the ascendancy. All the better class of stores display assortments of these trinkets that vie in beauty with any line of fine jewelry. Another specialty that is still enjoying the popular favor, commenced some time since, is bead necklaces, that are made in one to seven strands. John A. Riley, 860 Broadway, has been, and is, extremely busy in these lines, and has utilized the full capacity of his factory to produce a beautiful stock from which choice selections can be made. But his exquisite line of hairpins, side and back combs, must not be forgotten.

TABLE OF CONTENTS.

Apparatus for Mounting the Breguet spiral springs.....	85	Fashions in Jewelry.....	58	Jewelers' and Tradesmen's Company, The..	47	Proceedings of the Watchmakers' and Jewelers' Union	74
Around Boston.....	97	" Art Glass and Ceramics.....	62	Lathes and Lathe Work.....	81	Providence Notes.....	94
Chicago Briefs.....	45	Foreign Matters.....	57	Mechanical Ocular Defects.....	69	Quaker City, The.....	100
Communications.....	93	Gossip of the Month.....	25	Mining and Mineral Industry of the United States.....	54	Recent Patents.....	90
Complete History of Watch and Clock Making in America—Chronometer Makers	86	Gold Alloys.....	85	Model Watch Key Factory.....	86	Retrospect of the Paris Exposition.....	49
Crystal Anniversary of the N. Y. Jewelers' Association.....	30	Gorham M'fg Co's Subscription Book.....	47	New York Jewelers' Association.....	47	Trade Gossip.....	103
Convention of the Ohio Watchmakers and Jewelers' Association.....	73	Honor to the Trade.....	29	New York Jewelers' Board of Trade.....	47	Among the Watch and Clock Companies,	106
		Horological School Notes.....	46	Our Round Table.....	74	Universal Handle A.....	85
		Holiday Window Attractions.....	39	Paris Gossip.....	65	Workshop Notes.....	82
		Jewelers' League, The.....	69				
		Jewelers' Security Alliance.....	69				

INDEX TO ADVERTISERS.

Aby, Chas. Leo.....	79	Dueber Watch Case Mfg. Co.....	10	Lelong, L. & Bro.....	outside back cover	Shiebler, Geo. W.....	72
Aikin, Lambert & Co.....	71	Elliott, Geo. & Co.....	Inside back cover	Lewis Bros.....	95	Smith & Knapp.....	88
Alvin Mfg Co.....	92	Essex Watch Case Co.....	92	Logan, A. J.....	16	Smith, Alfred H., & Co.....	27
American Horological Institute.....	92	Evans, W. F. & Sons.....	83	Lorsch, Albert, & Co.....	Outside back cover	Smith B. & W. B.....	outside back cover & 38
American Waltham Watch Co.....	52	Falkenau, Oppenheimer & Co., Outside bk cov.		Marcy, F. I. & Co.....	76	Smith, H. M. & Co.....	79
American Watch Tool Co.....	63	Floyd, Pratt & Rounds.....	64	Mathey Bros., Mathez & Co.....	12	Special Notices.....	113
Ansonia Clock Co.....	3	Foley, John.....	96	McCall & Newman.....	88	Spencer Optical M'fg Co.....	7
Arnstein Bros & Co.....	22	Foley, D. F. & Co.....	56	Merritt, S. F.....	23	Stark, John.....	23
Atkinson Bros.....	51	Folkart, Wm.....	119	Middletown Plate Co.....	2	Sterling (The) Company.....	4
Atwater, William H.....	35	Foster & Bailey.....	51	Miller Bros.....	60	Stern & Stern.....	13
Baird, Henry Carey & Co.....	56	Fox, M. & Co.....	84	Moore & Horton.....	84	Stockwell, E. R.....	88
Ball, Wm. H. & Co.....	14	Fradley, J. F. & Co.....	28	Morse, Mitchell & Williams.....	19	Stratton, J. F. & Co.....	22
Barrows, H. F. & Co.....	Outside Back Cover	French, J. H.....	83	Myers, S. F. & Co.....	Inside Back Cover	Sussfeld, Lorsch & Co.....	84
Bartholomew & Peckham.....	119	Friedlander, R. & L.....	18	N. Y. Watch Case Spring Co.....	113	Taintor & M'Alpine.....	80
Bates & Bacon.....	35	Froelich, H. & Co.....	22	Newman, Louis, Jr.....	119	Tannenbaum, L & Co.....	72
Beguelin, Tell A.....	112	Fuchs, Ferd. & Bro.....	95	Nissen, Ludwig, & Co.....	71	Taylor & Bro.....	72
Berger, Albert & Co.....	12	Geneva Optical Co.....	18	Non-Magnetic Watch Co.....	48	Ternendt, F.....	119
Birch, John S., & Co.....	112	Goll & Co., Henry.....	20	Noterman, Jos. & Co.....	68	Todd, Ed. & Co.....	Outside back cover.
Blancard & Co.....	80	Gorham Mfg. Co.....	24	Nye, Wm. F.....	20	Towle M'fg Co.....	64
Bonnet, Jacob N.....	22	Haldemann, E. A.....	22	Odenheimer & Zimmern.....	120	Trenton Watch Co.....	108
Bookhout Bros.....	119	Hartford Silver Plate Co.....	21	Oppenheimer Bros. & Veith.....	79	Troemner, Henry.....	119
Bowden, J. B., & Co.....	91	Haskell, H. C.....	56	Oppenheimer, Henry E. & Co.....	63	Ullrich, J. L. & Co.....	22
Braxmar, C. G.....	119	Hausburg, O. E.....	119	Owen, G. & S., & Co.....	72	United States Watch Co.....	28
Bradley & Hubbard Mfg Co.....	64	Hearn & Braitsch.....	14	Pairpoint M'fg Co.....	6	Valentine, D.....	96
Brooklyn Watch Case Co.....	8	Hedges, A. J., & Co.....	71	Peterson & Royce.....	76	Valuable Instruction Books.....	118
Bryant, M. B. & Co.....	67	Hedges, Wm. S. & Co.....	87	Pforzheimer, Keller & Co.....	8	Wade, Davis & Co.....	67
Bynner, T. B.....	119	Heinrich, H. H.....	79	Pinnell, May & Co.....	84	Waltham School of Horology.....	56
Carter, Sloan & Co.....	59	Howard, S. P.....	Outside back cover	Pinover, A. & Co.....	55	Waltham Watch Tool Mfg. Co.....	20
Cattelle & Decker.....	76	Hyde's Sons John E.....	68	Plainville Stock Co.....	67	Wallace, R., Sons M'fg Co.....	63
Chalmers-Spence Co.....	83	Imhauser, E.....	119	Platt, Chas. S.....	Outside back cover	Want, Edwin.....	22
Champenois & Co.....	80	Jacot & Son.....	55	Prindle & Russell.....	Outside back cover	Washburn & Moen Mfg. Co.....	119
Chatham National Bank.....	32	Jacques, Charles.....	1	Queen, Jas. W. & Co.....	42	Watchmaker, Jeweler and Silversmith.....	112
Chicago Horological Institute.....	56	Jeandheur, F. Jr.....	96	Racine Jewelry Mfg. Co.....	119	Waterbury Clock Co.....	1
Clark, A. N.....	68	Jewett Mfg. Co., John C.....	17	Randel, Baremore & Billings.....	102	Waterbury Watch Co.....	75
Conover, D. F. & Co.....	15	Kahn, L. & M. & Co.....	14	Richardson, J. W. & Co.....	17	Weil, Maurice.....	88
Cooke, B. J's. Sons.....	68	Kaldenberg, J. F. & Co.....	111	Riley, John A.....	91	Weich & Miller.....	83
Cottler, C. & Son.....	119	Keller, L. H. & Co.....	112	Robert, J. Eugene, & Co.....	98, 99	Wheeler, Hayden W. & Co.....	91
Crescent Watch Case Co.....	52	Kendrick & Davis.....	83	Rogers & Bro.....	9	Whiting Mfg. Co.....	41
Cross & Beguelin.....	21	Kent & Stanley.....	23 & 60	Russell, Irving L.....	56	Wilkinson, C. B.....	119
Crouch & Fitzgerald.....	Outside back cover	Ketcham & McDougall.....	6	Sauter, L. & Co.....	84	Winship & Wiger.....	111
Cummings, Josiah & Son.....	120	King, Julius, Optical Co.....	3	Schleicher, Schumm & Co.....	88	Woglom, Gilbert T.....	88
Cuppia, L. A.....	96	Klaber, S. & Co.....	14	Scheidig, John & Co.....	22	Wood & Hughes.....	72
Day & Clark.....	16	Koeh & Dreyfus.....	101	Scott, J. T. & Co.....	107	Wood, Chas. F.....	80
Derby Silver Co.....	95	Kohlbusch, Charles.....	119	Seth Thomas Clock Co.,.....	Inside front covr	Wood, J. R., & Son.....	119
Didisheim, Hipp.....	84	Kremetz & Co.....	111	Sexton Bros. & Washburn.....	67	Zimmer, Henry.....	Inside Back Cover
Dorflinger, C. & Sons.....	28	Laurenot, J. B.....	120	Shafer & Douglas.....	31	Zineman, M. & Bro.....	84
Dreyfus, Henry, & Co.....	11	Lawson & Van Winkle.....	51	Sheaffer, W. H., & Co.....	72		

KETCHAM & McDOUGALL,

MANUFACTURERS,

GOLD AND SILVER THIMBLES,

The Automatic Eye-Glass Holder, Gold Collar Buttons,

198 BROADWAY, NEW YORK.

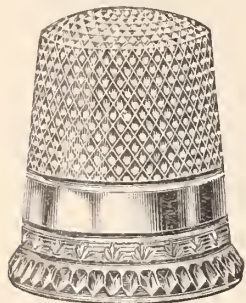

103 (New).

Same price as plain thimble

105 (New).

Same price as plain thimble

We offer to the Trade our **GOLD COLLAR BUTTON** (Patented July 12th, 1887). It is very strong, made **without Solder**, and finished **Spring Temper**. It has Radial Ribs both in head and back, where strength is most needed.

SAMPLES AND PRICE LIST FURNISHED ON APPLICATION.

PAIRPOINT MANUFACTURING CO.,

NEW BEDFORD, MASS.,

FINE GOLD AND SILVER PLATED WARE.



No. 2628.--Plain Gold Lined, \$4.25.



No. 3550.--Lunch Ser.

The Largest Line of Novelties of Wedding and Holiday Presents on the market.

New Lines

IN

Inkstands,

Button

Hooks,

Paper

Knives,

Letter

Openers,

Salad

Bowls,

Bon-Bon

Trays,

Etc., Etc.

CATALOGUES ON APPLICATION.

20 Maiden Lane,
NEW YORK.

90 & 92 Wabash Ave.,
CHICAGO, ILL.

220 Sutter St.,
SAN FRANCISCO, CAL.

Sydney,
AUSTRALIA.

PFORZHEIMER, KELLER & Co.,

24 JOHN STREET, NEW YORK.

— American Watches —

— Diamonds, Jewelry —

I. PFORZHEIMER }
D. KELLER }

I. B. ETTINGER,
H. J. FINK.

Readers, Please Mention **THE JEWELERS' CIRCULAR** When Writing or Buying.



THE JEWELERS' CIRCULAR

AND

HOROLOGICAL REVIEW.

OFFICIAL REPRESENTATIVE OF THE JEWELERS' LEAGUE, THE NEW YORK JEWELERS' BOARD OF TRADE, AND THE JEWELERS' SECURITY ALLIANCE.

It is also the Recognized Exponent of Trade Interests.

A MONTHLY JOURNAL DEVOTED TO THE INTERESTS OF WATCHMAKERS JEWELERS, SILVERSMITHS, ELECTRO-PLATE MANUFACTURERS, AND THOSE ENGAGED IN THE KINDRED BRANCHES OF ART INDUSTRY.

SUBSCRIPTION.—To all parts of the United States and Canada, **\$2.00 per Annum**, Postage Paid. To all Foreign Countries, **\$3.00 per Annum**, Prepaid.

All communications should be addressed to

THE JEWELERS' CIRCULAR PUBLISHING CO.,
189 BROADWAY, NEW YORK.

Advertising rates made known on application.



A full Index to Advertisements and Table of a Contents will be found on Page 5 of this issue.

READERS of THE CIRCULAR are urged to peruse attentively the article on window attractions in this issue. It is hoped that the illustrations given and the descriptions accompanying them will enable the reader to get some idea of the style of window dressing now in vogue among the principal jewelers of the metropolis, where the importance of the art of window dressing is becoming more clearly recognized daily. It is high time, therefore, that the retail trade throughout the country were devoting to it the attention that other trades have found so necessary and profitable. The problem is simple. The pedestrian and the shopper must be drawn to the window by the attractiveness or novelty of the display. This can be done by careful study of the laws of beauty as applied to this art. In this way not only is the name of the dealer most effectually advertised, but the eye of the on-looker is apt to be caught by some article of special interest, and a new customer is quite sure to be added to the jeweler's list. The wide awake jeweler must make a study of window attractions. If he comes to New York he should avail himself of every opportunity to inspect the best models the metropolis affords, and in his own town, too, he ought to be equally on the lookout for ideas. The field for novelty in window dressing is almost boundless, and there is no department where a sure return

can be counted upon for all expenditure of time and thought. The tendency of the jewelry trade heretofore has been too strongly toward conservatism in matters of this kind. Through this negligence the bazaars and dry goods stores have secured a pretty long lead in the art of attracting the public. But the jewelry trade must wake up, begin to court observation and get themselves talked about or lag behind in the race. We have the very best evidence, however, that the jewelers are at last bestirring themselves, and are determined to take a hand in this interesting little draw game. The result is that in every city of the land jewelers who make this a special feature are reaping a rich harvest of new custom.

* * * * *

"Holiday Window Attractions," page 43, with illustrations of model displays.

* * * * *

SLOWLY and with great effort the guarantee fund for the World's Fair of 1892 is being strained up to the \$5,000,000 point. Generally speaking, the appeals of the finance committee have met with a liberal response from the mercantile community, but the apathy that has been shown by the great corporations and semi-public institutions which would be the chief beneficiaries of the Fair, is highly discreditable to them, and would excite stronger feelings if we were not so accustomed to it. New York is certainly a favorable site for the World's Fair, but this conspicuous lack of enterprise on the part of her wealthiest men and her giant corporations may influence the congressional committee adversely in deciding upon a location. Indeed, this fact must be taken into consideration by the committee, and how will New York stand comparison with Chicago in this respect? Her merchants respond generously, her monopolists remain silent—and pocket the profits.

* * * * *

THE CIRCULAR takes pleasure in laying before its readers the only complete and accurate report of the crystal anniversary banquet of the New York Jewelers' Association, held at Delmonico's on November 21. It is the aim of this journal to place before the trade only reliable information, and no garbled or misprinted reports are hustled out at the sacrifice of accuracy.

* * * * *

FOR the last fifteen or twenty years travelers have occasionally brought specimens of a very remarkable amber from some locality in Southern Mexico. The only information gained concerning it is that it is brought to the coast by natives who say that it occurs in the interior so plentifully that it is used by them for making fires. The color of this amber is a rich golden yellow, and when viewed in different positions it exhibits a wonderful fluorescence, similar to that of uranine, which it also resembles in color. A recent specimen is even more beautiful than the famous so-called opales-

cent or green amber found in Catania, Sicily. This material would be extremely valuable for use in the arts. It is believed that an expedition has started for the locality where it is found in the interior.

* *

* *

* *

"Old Roman Jewelry," interesting archaeological find, page 66.

* *

* *

* *

THE tendency of the Anglo-Saxon civilization to override and crush out other civilizations with which it comes in contact is noticeable in the evident decay of native Japanese art. Since the introduction of European methods and ideas into that country the native artists seem to have lost their cunning. They have forsaken native traditions and now content themselves with a lame imitation of foreign models or a feeble repetition of stereotyped forms. The Japanese exhibit at the Paris Exposition showed clearly the present degeneracy of this beautiful school of art. The ravages of a conquering civilization are ruthless and complete. While it gives much to compensate for what it displaces or destroys, yet one of the things which must cause deepest regret is the swallowing up of a matured national art by the greater virility of the invader. We have learned many lessons from the Japanese, particularly in the line of silverware and ceramics, and it might be well for us to hold fast to what we have acquired, for it is extremely doubtful whether they will ever teach us anything more.

* *

* *

* *

Cut of the Exposition Medal, page 49.

* *

* *

* *

ACTING on the suggestion of persons interested in foreign trade, the Marquis of Salisbury has instructed England's representatives in foreign marts to send in to the Bureau of Foreign Affairs, all the information they can possibly glean as to the laws and regulations affecting commercial travelers in their respective countries, and it is the intention to collate and publish this information in a small blue book, which will be of great practical value to British merchants and their travelers in foreign territories. Here is a chance for our department of foreign affairs to render a service to the increasing class of American manufacturers who are seeking foreign trade. Such a book would surely be useful to many of them.

* *

* *

* *

Read M. Falize on American Silverware, page 49.

* *

* *

* *

RECENT advices from Switzerland announce that an advance of 10 per cent. to 15 per cent. on wages has been demanded by the confederation of Swiss watchmakers, that the majority of the manufacturers have accepted the men's terms and the remainder will probably yield. The movement, of which this is the culmination, has been gathering strength for three or four years, during which the unions of the different branches of the trade have been steadily increasing in numbers and in purpose. Strikes have been previously attempted but they have proved unsuccessful, because the organizations lacked both the numerical strength and unanimity to carry out their designs. Now, however, they are numerically strong and well cemented. The time chosen for the last strike was also highly favorable to the workmen, as all the manufacturers are so overrushed with business that they find it impossible to fill their orders. Hence they could not do otherwise than accede to the demands of the workmen for the present, at least. How long the advance will be maintained no one interviewed by THE CIRCULAR would undertake to say, but should trade slacken in the next few months the workmen will be

likely to lose much of the advantage they have just gained. The New York importers of Swiss watches say that the advance has come too late to seriously embarrass them this season, and that the probability is that prices will rule a little higher in the spring. From a broader standpoint the news is interesting, as it bears evidence to the increasing solidarity of the workmen. They are learning by experience how to combine. They are learning to govern themselves and discard violence, and from these schools of the workmen, from the trades unions, the guilds and the other labor organizations where free discussions are held, will come some of the ablest men of the future.

* *

* *

* *

Complete verbatim report of the crystal anniversary of the New York Jewelers' Association, page 31.

* *

* *

* *

THERE has been a good deal of dissatisfaction with the awards at the Paris Exposition, as might be expected. One or two meetings of dissatisfied exhibitors have been held at Paris, but their prolonged discussions have resulted in little except expressions as to the incompetence and favoritism of the jurors, and the drafting of resolutions recommending the abolition of jurors and awards at future exhibitions, and the substitution of a simple commemorative medal for all participants.

* *

* *

* *

Every wide awake jeweler has an optical department now-a-days, and ought to read our optical department, edited by Dr. C. A. Bucklin, M. D.—Vide, "Mechanical Ocular Defects," page 69.

* *

* *

* *

THE summary of imports and exports for September shows the following figures of interest to the jewelry trade: Imports of rough or glazier's diamonds, 1888, \$32,464; 1889, \$12,528; imports of clocks and parts thereof, 1888, \$59,837; 1889, 66,065; imports of watches, materials and movements, 1888, \$163,871; 1889, \$152,627; imports of jewelry and manufactures of gold and silver, 1888, \$101,476; 1889, \$149,569; imports of precious and imitation stones, 1888, \$824,675; 1889, \$1,244,871. Exports of clocks and parts thereof, 1888, \$88,289; 1889, \$103,824; exports of watches and materials, 1888, \$17,827; 1889, \$25,393; exports of jewelry, 1888, \$48,527; 1889, \$47,039; exports of plated ware, 1888, \$62,147; 1889, \$34,936. The most noticeable facts presented here are an increase of about 50 per cent. in imports of precious and imitation stones, and a considerable increase in exports of clocks and watches.

* *

* *

* *

See Holiday novelties gleaned by Elsie Bee.

* *

* *

* *

THE New York Institute for Artist-Artisans, 140 West 23d street, John Ward Stimson, superintendent, has commenced its year under favorable auspices. To provide room for the growing demands of the school the adjoining building has been annexed and conveniently fitted up for class rooms. Robert H. Hunter, with Tiffany & Co., has been engaged to give instruction in the department of jewelry and metal work, and competent specialists hold forth on ceramics, stained glass and other branches of trade. With two such able principals as Professors Stimson and Diehl, the school is thoroughly equipped and will fill a place hitherto unoccupied in American educational work. For the convenience of those who cannot come by day, it has been decided to open the school on three evenings a week. THE CIRCULAR can cordially recommend this school to any who may be contemplating a course of instruction in applied art.

Honor to the Trade.

We present our readers this month with a portrait and sketch of Hiram Howard, of Howard & Son, Providence, R. I., who on the 18th of November, received the unanimous nomination of the local Democratic convention for the office of Mayor of Providence.

Hiram Howard was born in Woodstock, Conn., Nov. 26th, 1834. He received a common school and academic education in his native town, and when 18 years of age he went to Providence, and obtained employment with the firm of Moulton & Rodman as book-keeper. His ambitions being more metropolitan than could be gratified in his adopted city, he went to New York and engaged with T. B. Bynner, the well known jobbing jeweler, remaining in his employ until 1858, when he was admitted to a partnership, the name of the firm being changed to T. B. Bynner & Co. He remained a member of the concern until 1861, and then enlisted in the 2d Regiment Artillery, New York Volunteers, and was honorably discharged after three years' service. He again engaged with T. B. Bynner in 1864, as traveler, was soon admitted into the firm, and remained a partner until 1874. From March 1 of that year until January, 1875, he was with the firm of L. A. Kotzow & Co., selling their product of solid gold chains. He then formed a partnership with Mr. Nicoud, under the firm name of Nicoud & Howard, importers of watches, which relations lasted until 1880.



HIRAM HOWARD.

But during the meantime, in the year 1878, Mr. Howard began at Providence in a small way the manufacturing jewelry business, under the firm name of H. Howard & Co., making a line of sets, which during those days were popular with the trade. Thus when he relinquished his partnership with Mr. Nicoud, he had a business started which required his undivided attention. It had always been the desire of Mr. Howard to be at the fountain head, for as long ago as he had relations with Mr. Bynner, he worked persistently to get the consent of his partner to enter the manufacturing business, wishing to offer to their customers goods of their own design and make, rather than depend upon the skill of others to produce the articles they could handle. In 1884 his son, Stephen C. Howard, was admitted a partner in the business, and the firm name adopted was Howard & Son, remaining the same ever since. Mr. Howard has been connected with manufacturing about ten years, starting small, and doing a safe, steady and constantly increasing business. In the fall of 1885 the firm conceived the idea of adding a separate branch to their line of production, and the Sterling Company was formed, which from the start has been a ready means of increasing their sales

and bringing them into the acquaintance of a new line of customers. In this short period the productions of the Sterling Co. in silver have taken a rank with the best in the land in this line of industry. In 1887 the growth of business rendered a removal necessary, and the desired accommodations were found in the new building of Kent & Stanley, 7 Eddy street, where these two concerns occupy one of the best appointed factories in the city.

Mr. Howard has been connected with the Manufacturing Jewelers' Board of Trade since its organization, and for the past year has been a member of its Board of Directors. He is also a member of the Vue de l'Eau Club, and the Rhode Island Yacht Club, of Providence, Eureka Lodge, No. 243, F. & A. M., of New York City, and the Reform Club of the same city, and he is also a member of the present Legislature. He is one of the most public spirited citizens of Providence, and has a large circle of friends in both social and political spheres. If he is elected to the mayoralty, Providence will be assured of an energetic and independent head of municipal affairs.

New York Jewelers' Board of Trade.

At the regular monthly meeting of the Board of Directors held at their rooms on Thursday, the 14th inst., the following firms were admitted to membership:

Duhme & Co., Cincinnati, O.; Hodenpyl & Sons, 170 Broadway; Jacobson Bros., 14 and 16 Maiden Lane; Randel, Baremore & Billings, 29 Maiden Lane; Brooklyn Watch Case Co., 192 Broadway; Bates & Bacon, 196 Broadway; Julius King Optical Co., 4 Maiden Lane.; J. F. Fradley & Co., 23 John street; R. Wallace & Sons Manufacturing Co., Wallingford, Conn.; Waterbury Clock Co., 10 Cortlandt street. Howard & Son have applied for admission to membership.

Amounts collected up till Nov. 23d by the Board, toward the New York World's Fair Guarantee Fund of \$5,000,000, are as follows:

Samuel Eichberg.....	\$1,000	Day & Clark.....	\$300
Oppenheimer Bros. & Veith...	1,000	Julius King Optical Co (Leo Wormser, Manager).....	250
Enos Richardson & Co.....	1,000	Sol Lindenborn.....	250
Keller & Untermeyer.....	1,000	Levy, Dreyfus & Co.....	250
Stern Bros. & Co.....	1,000	Spencer Optical Mfg. Co.....	250
Jos. Fahys & Co.....	1,000	Lewis, Kaiser & Luthy.....	250
L. & H. Kahn & Co.....	1,000	Downing, Keller & Co.....	250
Sussfeld, Lorsch & Co.....	1,000	Leopold Weil & Co.....	250
Bruhl Bros. & Co.....	1,000	Ferd. Bing & Co.....	250
G. & S. Owen & Co.....	500	Jacot & Son.....	250
Albert Lorsch & Co.....	500	M. Fox & Co.....	250
Louis Herzog & Co.....	500	Morris Prager.....	250
Adolphe Schwob.....	500	Ingomar Goldsmith & Co.....	200
Koch & Dreyfus.....	500	L. Santer & Co.....	100
Stern & Stern.....	500	Lambert Bros. & Co.....	100
S. F. Myers & Co.....	500		
Wm. Smith & Co.....	500		
Max Freund & Co.....	500		
			\$16,950

The above is fine showing when we remember that the Board only received the subscription book on November 11th.

H. D. Sherrill has been elected a member of the Finance Committee in place of President Leopold Stern.

CONSULAR advices from Brazil announce that the government has issued a decree permitting any town to levy a tax up to £50 on any commercial traveler who sells with the help of patterns. This is not only an imprudent measure and contrary to the interests of the country, but commercial travelers easily evade it by sending their patterns from town to town, and selling goods accordingly under the cover of the address of a merchant, who exposes them for sale with his own goods. The traveler, however, whilst he stays in the town enters the service of the merchant as a "clerk," and thereby gains another and very important advantage, which is, that he studies and makes himself thoroughly acquainted with the practical business ways of the Brazilian merchant. This affords a good example of the manner in which laws in restraint of natural rights, foster perjury, fraud, hypocrisy and all the other sins in the calendar.



[FROM OUR SPECIAL CORRESPONDENT.]

CHICAGO, NOV. 20, 1889.

Joe Schwartz and his peculiar financiering has, perhaps, occasioned as much comment here during the past few weeks as in Kansas City. It is positively known that quite a number of Chicago jobbing jewelers, clock companies and silverware manufacturers are losers, but none can be found who will plead guilty to the soft impeachment. Joe's character and methods were so well known here that it is no wonder that those of the trade who were nipped should feel disinclined to own up.

The flattering prospects of a month or so ago respecting winter trade cannot be said to have entirely materialized, but, as compared with a year ago, the volume of trade shows quite an improvement. As for collections, they never were in a more satisfactory condition and indicate that the jewelry trade in common with other mercantile interests have come to realize that the old-fashioned habit of long credits and the asking of extensions is out of date, and that frequent cash buying with prompt cash settlements is the only pathway to solid success.

That the jobbing trade are fully prepared for holiday orders is apparent to the most casual observer, and especially is this noticeable amongst the silverware agencies. The Gorham Manufacturing Co., in addition to their regular lines of sterling silver, show a more comprehensive assortment of lower cost articles than ever before. Conspicuous amongst these are scissor-shaped cigar cutters fashioned like old-fashioned candle snuffers, silver cased memorandum books, tooth powder boxes, cloak clasps, scissors, hair-pin trays, three-piece sets of bowl, sugar and creamer.

Those who imagine that the five and six-bottle table casters have all been "called in," make a mistake. Boston, New York and Chicago may turn up their noses at this old friend, but America is a big field, and the prairies of the far West have so greatly increased in population that the silverware manufacturers state, as a matter of fact, that they are selling quite as many casters as in the days when they graced every table.

Our near-by suburb of Aurora is still scratching its head over the Aurora Watch Company problem. The inhabitants of this brisk little town seem quite determined to keep the factory, which paid out in the month prior to its assignment some \$15,000 to the operatives, thus increasing by so much the trade of the town, and they are making every effort to that end. Assignee Evans continues steadfast in his refusal of the \$100,000 offer of Eppenstein & Silverman, of this city, and that he is fully justified in this, is shown in the offer of \$5,000 for a thirty-day option to buy the plant for \$50,000 more than the offer just mentioned. This last proposition comes from St. Paul people. The report that a syndicate of Aurora and Chicago people had been formed, which found its way into the columns of a New York contemporary, was entirely without foundation. Assignee Evans, in speaking of Eppenstein & Silverman's offer, says: "It's simply absurd; the plant represents an investment of half a million of dollars, and there are \$68,000 worth of movements nearly completed."

The Blauer Watch Case Co. has been removed, bag and baggage, to Kenosha, and will hereafter be known as the Kenosha Watch Case Co., with W. C. Taft still remaining as manager and with the Chicago office at No. 149 State street, under the charge of Thomas Rooney.

The amount of money raised by Chicago jewelers for the World's Fair fund has already passed the \$100,000 mark.

Chicago has long been famed for the publication of the most com-

plete jewelry catalogues issued anywhere in the world, and, while some objection has recently been urged in other journals to the publication of these price catalogues with their realistic illustrations on the score that it destroyed the retail jewelers' profit, yet it must be understood that this objection only holds good with reference to the price-lists and small catalogues sent out broadcast by the retail catch-penny houses, whose name is legion, and who simply tack on the words "Manufacturers and Wholesalers," in order to attract those foolish folk who are always determined to risk their money in untried fields. Chicago's large jobbing jewelers state that they do just the reverse of this. The price published covers the cost and a handsome profit, subject to a discount which none but the jeweler is cognizant of, and these catalogues become the retailers' sales book, operating to his distinct advantage and profit. Many of them have no other name than the retailer's on their covers and title pages. Lapp & Flershem were the first to introduce the idea of those "nameless" catalogues, and their example has been followed with profit. These catalogues are as near perfect as it would seem possible to make them, and most of the jobbers have their own printing establishments in connection with the ware-rooms. The last to be issued of these books is that of Morse, Mitchell & Williams, 15,000 of which have been distributed during the month with most gratifying success, and the compilers of it have been frequently complimented since its issue for having published a catalogue, so systematically arranged as to enable the jeweler to turn to any desired article instantly.

The buying up of old gold will be found exceedingly profitable to those jewelers who will remember that such establishments as that of F. Ternendt, 57 Washington street, Chicago, make it up into plain rings at a cost of but 9 cents per dwt.

Considerable curiosity has been expressed by travelling salesmen, who have come here from New York, since the return of H. A. Spaulding from Paris, as to whether or no the West was sufficiently advanced in wealth and culture to appreciate and to be able to purchase the enormous quantity of precious articles imported from Paris by Spaulding & Co., the Chicago jewelers. It will be gratifying to all identified with the progress of the jewelry trade in the West to know that thus far the success of the Spaulding & Co. venture has exceeded all expectations. Such sales as a thousand dollar center-table, inlaid with hand painted porcelains, Dresden and Sevres vases having each a value of from \$500 to \$2,000, marble statuary, costly fans and other Parisian novelties, to say nothing of high cost watches and jewelry in general, are matters of daily and even hourly occurrence. Mr. Spaulding has at last permanently established his residence in Chicago, and has a beautifully furnished home near Potter Palmer's well-known residence on the Lake Shore Drive. Edward Forman, secretary of the Spaulding & Co. corporation, returned from a fortnight's visit to New York to-day.

A. S. Smith, President of the Geneva Optical Company, of this city, returned from a visit to the Geneva New York factory yesterday, and leaves to-night for Denver, Kansas City and other western cities. The purpose of the eastern trip was to urge upon those in charge of the factory the increasing demand on the Chicago company for their popular goods. This increase of business keeps all hands busy filling orders, and is an unfailing indication of this company's prosperity.

Dame Rumor has again insisted that the Elgin Watch Company had been offered, and would probably accept, \$12,000,000 for the works from an English syndicate. In fact, a morning paper, yesterday, announced the transfer as having been made. Concerning it Mr. Avery said:

While the brewery syndicate was here months ago the possible value of the works was discussed in a general way, but no specific offer was made, and no talk that could be indirectly construed as an offer was indulged in. The country is overrun with brokers out on their own hook looking for options on American holdings for possible sale in England, and these have visited us, but none of them has ever been given an option. The property could not be sold without the individual consent of 100 stockholders.

THE CIRCULAR'S OBSERVER.

Crystal Anniversary

Of the New York Jewelers' Association, celebrated at Delmonico's, November 21st, 1889.

On Thursday, November 21st, Delmonico's banquet hall and the gentlemen of the New York Jewelers' Association were arrayed in their finest in honor of the 15th or crystal anniversary of the association. The *chefs de cuisine*, the disciples of Terpsichore, and the orators who graced the occasion, put forth their best efforts to make it a memorable anniversary in the history of the organization. The occasion merits a moment's retrospect. The association had its birth in 1874, in the building now occupied by the Waltham Watch Company in Bond street. The late Moses G. Baldwin, of the firm of Baldwin, Sexton & Peterson, was the first president, and was succeeded by the late Seth W. Hale, then of the firm of Mulford, Hale & Cottle. Jacques Guedin, now deceased, of the old-time firm of Ve J. Magnin, Guedin & Co., importers, was then chosen to fill the office. The association's next president, Daniel F. Appleton, proved so efficient and popular that he was re-elected twice, serving for a period of three years (1877-80). Ethel C. Hine, connected with the American Clock Company at that time, but now a resident of San Francisco, was Mr. Appleton's successor for two terms, at the expiration of which the members chose Thomas G. Brown, of the firm of Thomas G. Brown & Sons, unanimously re-electing him for a second term. From 1884 to 1886 William R. Alling, of Alling & Co., sat in the executive chair, the dinner at which he presided being given at the Hotel Brunswick. George C. White, Jr., of Rogers & Bro., was president for the term of 1886-87, and though tendered a renomination, was obliged to decline on account of pressure of business. Alfred H. Smith, of Alfred H. Smith & Co., and H. B. Dominick, of Dominick & Haff, next wielded the gavel, each for one term. The eleventh president, Frederick S. Douglas, of Shafer & Douglas, ring makers of 3 Maiden Lane, was elected in October last, and is proving an able officer, his easy and dignified bearing, and exceptional administrative ability rendering him well adapted to such a position of honor and responsibility.

At 6.30 P. M. the members and guests began to assemble in the parlors of the establishment and after a half hour of social converse marched out to the banquet hall two by two, President Douglas and General Sherman leading the way. Prayer having been offered by the Rev. A. J. F. Behrends, the banqueters took their seats. The tables were superbly decorated with flowers, and the walls were gay with patriotic emblems, chief of which, a Columbia shield enwrapped by the Stars and Stripes and the Union Jack, was placed over the chair occupied by the president. Masterpieces of the silversmith's art, loaned by Tiffany & Co. for the occasion lent characteristic splendor to the scene, while the hand-painted favor and the boutonniere for each individual guest were not forgotten. Wine and wit flowed in pleasing mixture, the wit giving to the wine a choicer flavor. The speeches were quite felicitous, round after round of applause greeting the brightest sallies. Throughout the whole affair nothing occurred to mar the general harmony and good feeling that prevailed, and all present voted another successful dinner for the Jewelers' Association.

At the main table, on the elevation giving a full sweep of the assemblage below sat President Douglas, and the speakers of the evening: General W. T. Sherman, Rev. A. J. F. Behrends, General Horace K. Porter, Hon. Granville P. Hawes, Hon. Isaac H. Bailey, Rev. John R. Paxton, Ex-Judge Noah Davis and Robert B. Roosevelt. Chauncey M. Depew and Roger A. Prior, had been invited to

be present but were unable to partake of the hospitalities of the Association much to the regret of those who had so often been charmed by their eloquence. The most noticeable silver pieces adorned this table, among which was a gigantic punch bowl of repousse work, surmounted with familiar scenes from the old masters. Above and around was a gorgeous display of bunting, gay colored flags of all nations blending in fraternal folds. From its Alhambra like station aloft, the orchestra of the Newport Casino regaled the feasters with appropriate selections from popular composers, frequently suiting the music to the occasion, as, when General Sherman received his ovation, "Marching through Georgia" resounded through the hall, and when the company rose to depart the slow, touching strains of "Home Sweet Home" quickened the steps of the retreating banqueters homeward bound. Almost all bore away some memento of the occasion, a bon bon box in imitation of a watch, filled with sweetmeats, a bunch of flowers from the tables, or some other souvenir worthy of preservation.

The following is a list of the banqueters;

President F. S. Douglas, Hon. Robt. B. Roosevelt, ex-Judge Noah Davis, Rev. John R. Paxton, D. D.; Gen. Wm. T. Sherman, Hon. Henry C. Pitney, Rev. A. J. F. Behrends, Hon. Granville P. Hawes, Gen. Horace Porter, Hon. Isaac H. Bailey, President F. S. Douglas, Vice-President J. B. Bowden, Nicholas Geoffroy, J. N. Taylor, T. B. Hagstoz, J. A. Lebkuecher, Geo. Krementz, J. M. Rourke, E. E. Kipling, E. F. Sanford, F. H. Mulford, W. H. Thurber, T. B. Brown, A. Dominick, F. C. Thomas, C. Clarke, H. B. Dominick, J. F. Pedersen, J. G. Bacon, H. A. Lambert, H. Unger, L. H. Mattison, E. Unger, D. H. Barnet, A. Lelong, T. J. Harris, I. Mills, W. S. Foster, D. F. S. Forshay, J. P. Snow, H. C. Ostrander, J. R. Greason, I. M. Miller, J. W. Miller, B. F. Schmock, F. C. Cooper, E. Aug. Neresheimer, J. S. Franklin, Geo. R. Howe, Geo. B. Jacques, C. E. Hastings, W. S. Thompson, John C. Mount, H. K. Dyer, W. W. Wattles, Chas. L. Powers, Fred Simons, C. E. Bride, S. Cottle, F. W. Hoyt, E. T. Bartlett, C. H. Solomon, Jas. H. Hart, Gen. Geo. H. Ford, A. K. Sloan, Robert C. Black, A. Carter, Jr., Geo. W. Russell, W. H. Curtis, I. G. Dillon, E. Schall, C. S. Saxton, T. K. Benton, Wm. Riker, Jr., C. G. Alford, Geo. M. Hard, J. W. Senior, E. V. Clerque, W. F. Stahl, W. C. Kimball, F. C. Archambault, W. R. Alling, R. A. Pinkerton, H. S. Cozzens, J. D. Alling, Geo. W. Biggs, H. B. Beach, W. L. Cook, W. H. Fairbank, C. A. Fowler, F. Sloan, M. L. Bowden, A. N. Wood, J. F. Perkins, A. F. Wise, A. L. Brown, P. K. Hills, Jr., J. W. Appleton, Irving Smith, A. E. Johnston, N. H. White, J. H. Johnston, W. H. Vogel, C. S. Hirst, H. B. Smith, H. C. Ward, A. H. Pray, Geo. Wilson, Westcott Bailey, A. H. Smith, R. M. Hyde, J. B. Mayo, A. O. Headley, F. B. Mandeville, M. D., J. H. Shafer, F. A. Smith, S. P. Avery, W. H. Hennegen, A. E. Pritchard, Ludwig Nissen, A. C. Chase, R. S. Ferguson, S. A. Bryant, A. A. Webster, J. A. Lewis, R. N. Peterson, Geo. C. White, Jr., John H. Heiser, H. C. Hardy, H. E. Ide, C. M. Cram, E. P. Ingersoll, A. C. Smith, Col. C. L. Thompson, L. J. Mulford, John A. Riley, C. C. Adams, L. S. Lewis, P. W. Taylor, L. Barre, Geo. W. Shiebler, L. Sunderlin, J. C. Atwater, L. C. Norvell, W. H. Atwater.

At the heads of the five tables on the lower banquet floor sat the following gentlemen: at the head of the first table, ex-President Dominick; at the head of the second, Aaron Carter, Jr., at the third place of honor, vice president J. B. Bowden; at the fourth, ex-president D. F. Appleton, while the fifth table was presided over by W. H. Atwater, of the executive committee.

After the courses had been served and cigars had been passed, the President rapped his gavel on the table and called the assemblage to order. He then addressed the company as follows:—

ADDRESS OF PRESIDENT F. S. DOUGLAS.

Gentlemen:—The hour has arrived when the President is expected to say a few words of welcome and congratulation to the friends and members of the Association, and to make a little speech by way of introduction to the "feast of reason and flow of soul," which are to follow the mere material feast which has just engaged your attention. The first part of the President's duty is a most agreeable and grateful one, and it is with sincere pleasure that, on behalf of the Association, I extend to all our friends a hearty welcome to this our Fifteenth Annual Dinner; the one meeting of the Association at which we never have any difficulty in securing a

quorum. By common consent the fifth and tenth anniversaries of the wedding day are known respectively as the wooden and the tin weddings, and the fifteenth return of the day is denominated the crystal anniversary. It seems to me that there is a peculiar fitness in calling this the Crystal Anniversary of the New York Jewelers' Association, for in looking over this assembly, in which there are so many of the familiar faces and representative men of the trade, I see no indications of anything wooden about them, while, if outward appearance be the criterion, the "tin" period has long ago been reached, and must have panned out satisfactorily. I am sure that those who know us best will acknowledge that I am only speaking the cold truth, and confining myself to a modest statement of simple fact when I said the intrinsic purity and clearness and the polished and sparkling brilliance of the many sided crystal are the fit emblem and illustration of the gentlemen before me, the representatives and exponents of the jewelry trade to-day. While, therefore, I give a cordial greeting to our friends, so many of whom have come from a distance to honor us with their presence to-night, I congratulate the Association upon having reached its crystal anniversary.

Thus far the President's duty is as easy as it is agreeable, but the little speech that constitutes the other part of his task is quite another matter, and one against which I feel constrained to enter a decided and emphatic protest. We have with us to-night these able and reverend divines to whom thousands listen as from week to week, with impassioned utterance and burning eloquence, they proclaim the Sacred Truth. From them, as they speak to us this evening, we may reasonably expect wise counsel and instructive lessons clothed in clear, forcibly and beautiful language that shall command at once our attention and our admiration. Such an expectation is natural and justifiable. Their education and training have been in that direction, and the constant exercise of their talents has developed and perfected their ability. Moreover, they have the whole of the Sacred Book from which to choose the special truth they desire to impress, and consequently they have usually the advantage of a text of their own selection.

So, too, as we listen to these eminent representatives of the bench and the bar, we may justly expect from them scintillations of humor, sparkling repartee and coruscations of intellect that shall delight and entertain us all. Like the dogs that "delight to bark and bite," "it is their nature to." But I submit it is as unreasonable to expect the President of a Jewelers' Association to make a speech here to-night, as it would be to expect these reverend gentlemen to preach without referring to religion, or to ask our legal friends to argue a case without referring to the law.

There are times when a jeweler can speak—times when he even waxes eloquent, for eloquence is defined as "the expression or utterance of strong emotion in a manner adapted to excite correspondent emotion in others. In the light of this definition I venture to say that if to-night, instead of the tempting viands which have been spread before us, these tables had been covered with samples of the tasteful and beautiful products of the jeweler's and silversmith's art, and surrounded by such a multitude of friends and customers as are gathered here, there would have been an outburst of eloquence from the members of this association that would have excited the liveliest kind of emotion, even in the most unresponsive breast, and that would have convinced the most skeptical that the jeweler has a reserve fund of eloquence that needs only the proper text and occasion to flow forth like the mighty torrent that overleaps or sweeps away every obstacle in its course. From the absence of any such occasion for eloquence here, it naturally follows that I cannot reasonably be expected to make any formal speech. I will content myself, therefore, with a very brief allusion to the condition of our Association.

The principle that "in union there is strength" has been known and recognized in this country from the time when a few feeble colonies banded together, and by united action broke the hold of Great Britain upon them. But it is only within a comparatively few years that business men have realized that their safety and prosperity depend largely upon the adoption of this same principle in their business relations. The advantages resulting from its practical application were so immediately apparent, that its use has rapidly become general, until now we see it everywhere, from the union of the unskilled laborer to the gigantic combinations of capitalists and corporations, whose operations are chronicled with every issue of the daily newspapers. This Association is the outgrowth of the same principle, and its continued existence and its growth during the past fifteen years have demonstrated that, side by side with the keenest competition, there may be union and association for the protection and advancement of mutual interests, and that the prosperity of each can be best secured in the endeavor to promote the interest of all. I am glad to report that it is larger and stronger to-day than at any time since its organization, and its prosperity is shared by the individual members largely for the reasons that the principles that underlie success, honor, integrity and diligence are characteristic both of the Association and its members. Let me express in conclusion, the earnest wish that the growth, the usefulness and prosperity of our Association may keep pace with its years and its annual dinners until it shall celebrate not only its silver and golden anniversaries, but in the years to come, even its centennial. [Applause.]

At the close of his address, President Douglas continued—Although we meet here to-night as jewelers, we all may claim to be patriots, and there is one toast that will invariably appeal to an assemblage of gentlemen gathered together. The toast I am about to propose is one that is received in every gathering of patriotic Americans with enthusiasm. I will ask you all to rise and drink to the health of the President of the United States.

After the toast was duly honored, the President continued:

Gentlemen, the next regular toast of the evening has also a flavor of patriotic sentiment:

"The Progressive American: His tracks are visible from Ocean to Ocean."

I will call upon General Horace Porter to respond.

General Porter spoke as follows:

ADDRESS OF GENERAL HORACE PORTER :

Mr. President and Gentlemen of the New York Jewelers' Association: I hardly expected I would be called upon to cast the first fire brand into this orderly and peaceable assembly; to be the first one to enter here "and beard the lion in his den, the Douglas in his hall." We always believed that jewelers were singular and the regret of husbands is that their chief female customers are not single. If such were the case it would probably prevent many a husband's pocketbook from looking in course of time as if it had been stepped on by an elephant, for after a wife has spent eight days out of a week in jewelers' stores, the husband is apt to use language that is italicized, and he does not perhaps in her presence, pose as an understudy for an angel. It is evidently a man whose heart had been hardened and withered by these practices who said to the census taker, when he called upon him and asked if he was a man of family: "Yes, my wife has a husband and four children." (Laughter.) I have no doubt it was the man subjected to this state of mind who got to discussing the beatitudes of heaven with his friend, telling him that every one would be happy there. His friend remarked: "How can you say happy when you have a knowledge of all the evil that is going on on earth? Could you be happy in heaven knowing that your wife was sizzling in hell? He said, "Perfectly."

Now all this shows that married men regard jewelers' establishments as places to be admired, respected and—avoided. (Laughter.) If there is one woman whom I admire more than any other it is Cornelia of old who pointed to her children and said: "These are my jewels" which may be taken as one reason why Cornelian jewelry has not been popular in the trade. (Laughter.) I know that women sometimes wreak their vengeance on jewelers by spending five or six hours overhauling their goods and purchasing nothing after all.

A lady of my acquaintance spent three hours looking at some bracelets in a New York store, and when she had got through she inquired of the polite young salesman if they were in the latest style. He replied "They were madam, when you began looking at them." We have jewelry presented to us at every turn in life, from the "Samuel of Posen" who displays his wares on his tray at the street corner, to the mammoth establishment of Tiffany, the only difference being that the former is willing to sell you any thing from a match box to a clock, while art is the characteristic of the latter.

The man whom I dread most, gentlemen, is the commercial drummer sent out from New York. He takes the best rooms in the first-class hotels and is always too precious for any thing. He goes about the country with a trunk the size of a Noah's ark, and is irrepresible. The drummer moves rapidly—as we use to do in the army when we carried only a hair-brush and tooth-brush, and never used either. Once when Dr. Patton, the new President of Princeton College went to Chicago he stopped at a hotel usually patronized by drummers. He was shown to a handsome suite of rooms, when he objected saying "I don't want any thing more than a bedroom." "Then, said the servant, where do you expect to show your samples?" I made a trip a year ago to Washington Territory, now the State of Washington, and as usual the drummers were there in force. The proprietor of an establishment in New York telegraphed to one of them out there "If you are not making expenses, come home." "Making plenty of expenses here, but no profit," was the prompt reply. (Laughter.) Half a dozen of them were sitting down at a table in a restaurant one night scattering masses of stuff around their plates. Finally they got into a hilarious mood, and decorated the table cloth geographically, using the molasses pitcher as a means of filling in blank spaces. The pretty waiter girl in attendance came around, and they asked her her name. She said it was Pearl, when they one and all shouted: "Are you the Pearl of great price?" She said: "No, I am the Pearl before swine. (Laughter.) There is no event of importance that occurs in the world that you gentlemen do not work up into a relic—an object of beauty and a joy for ever. But I have lost faith in relics since the surrender at Appomattox, for I have seen an apple tree far from the scene of activity hewn down and cut into small pieces and worked into relics, from a corkscrew to a five pound paper weight. I lost my confidence in relics and apples at the same time, and I no longer believe in the efficacy of apple jack or that Newton discovered the principle of gravitation by the fall of an apple. If it were not in Holy Writ I could not have believed that there ever was an apple tree in the garden of Eden. If you are ever at a loss for relics, go to Boston, and they will sell you a spoon which came out of the Mayflower. If they have not one in stock they will tell you to call in a day or two, but the lie itself is worth half the money. (Laughter.)

Then the jewelers furnish the appointments for ladies at times—I had almost said clothing—at such times when balls are given for charity, and when the rich undress themselves for the purpose of dressing the poor. (Laughter.)

But to continue the discussion of this toast I may say I have not attempted to stick literally to it, because from previous experience I have arrived at the conclusion that there was a penalty inflicted on any speaker who so far forgot himself as to allude to the subject of his toast. I recollect, however, that the toast is about the "Progressive American Citizen, whose tracks are visible from ocean to ocean. That reminds me of the Illinois farmer, who was visited by a Missionary, doubtless from the church of Dr. Paxton, and when the Missionary asked: "Can I leave some of my tracts around here?" The farmer replied: "As many as you please, provided the heels are toward my house." (Laughter.) I am not inclined to dwell further upon this toast as I am going to start to-night for Boston. I know it is a rash thing to do, and I am also aware that when people go from this wordless city to Boston, they generally journey by way of Philadelphia in order to break the fall. When a man asked a friend how far Boston was from New York the reply came: "Two hundred and thirty miles in distance, two hundred and thirty years in custom.

Let me in conclusion, gentlemen, thank you for the pleasure I have experienced to-night, and wish in parting, all success to the men who have converted a trade into a high art, and made it the art commemorative of arts, for there has been laid under tribute to it every branch of science and of art. To produce the materials which the cunning of your art has laid bare to the world, workmen have reached down and wrested from reluctant nature the beauties of the mine and the secrets of the sea. You, gentlemen, have dignified labor; you have made of your workmen not artificers but artists. Your shops no longer display mere goods but are art galleries. You have done more than others to cultivate high taste and adorn life. The luxury of to-day becomes the necessity of to-morrow. You have even since the creation of the world done more than any other craft to adorn the beauties of life. From the building of Solomon's Temple to the marvelous works which we see taking prizes in modern international expositions. From the tender girl to the blushing bride and the mature woman, from the engagement ring of the

peasant to the diadem of the queen, your art has woven the decoration of all. (Applause.)

President Douglas—Gentlemen, I always have had a pretty good opinion of the jewelers and I think more of them than ever after hearing the speech of General Porter.

The next toast is:

"Honor and Honesty: Indispensable Factors of a truly successful life."

I will call upon the Rev. John R. Paxton to respond to this toast:

Dr. Paxton spoke as follows:

ADDRESS OF REV. JOHN R. PAXTON.

Mr. President and Gentlemen of the New York Jewellers' Association: Judge Davis on my right has impressed me with a feeling of awe. He has told me that in all his long public life—I do not think he said public life, because he is not fifty years of age yet—he told me when he sat down here to-night at this table that he had never seen at all the dinners at which he had been a guest so fine a looking body of men as he has witnessed to-night. Now if you have any fault to find with that statement find it with Judge Davis, and not with me, because he impressed me to rise to the occasion like the fellow who went to Tiffany's and bought a blue china teapot. Taking it home to his wife he said: "Miranda see this teapot," and she answered "Oh, Augustus, let's try and live up to it."

The jewelers' association—well, you are the people after all. Don't you know that before mankind had clothes they had ornaments. It is a fact. Utility comes after decoration. I dare say that Eve in the garden of Eden made bracelets out of the curling vines and decorated her hair with flowers before she found out fig leaves had a use. Yes, you are the people.

Decoration to-day on the Congo, in Africa, precedes utility. We did not find out agriculture before we found out ornamentation. You can not find a sava re to-day in all the world that does not have some paint on the body or a ring in his nose or ears furnishing proof that ornamentation in God's sight goes before utility. And when you and I, as we all must cross the big divide, on the other side we shall find that Mr. Depew and his railroads will not be wanted because we shall have wings there. The Standard Oil Company monopoly will not be needed as no artificial light will be required, but on the other side as I read in the Bible, there will be gates of pearl, streets of gold and the foundations thereof shall be of amethyst and emerald, and the jeweler shall still delight in his old occupation.

Sometimes in my meditative hours life seems to me in this big useless world of ours like an inn. You and I arrive out of the darkness and we enter. Some of us get a seat at Delmonico's, and others are relegated to the loft. Some of us like Lazarus eat crumbs on the door step. One day while we are dining and feasting new comers enter out of the darkness and demand your knife, your fork, spoon and plate, and we are all gone back into the darkness from which we came.

What strikes me as to this banquet which is provided for us in this world is that God who made the great world is as much in favor of ornament as he is in favor of utility. Man cannot live without beauty and no nation has yet existed which has not cultivated adornment. This feast of yours to-night shows to me that the jeweler was one of the first creations of God, and that every thing in this world is to be ornamented. So that while we are here we must remember that life is a pilgrimage which is to be spent in adorning ourselves, in recognition of the goodness of God.

Honor and honesty: The indispensable factors of a truly successful life. Is this world growing better or worse? Dr. Johnson once so asked Boswell, and answering the question himself decided that it was growing worse but it was more kind, humane, benevolent, philanthropic. Don't you know that your machinery and chemical devils have enabled us to adulterate every thing consumed by humanity and placed dishonesty in the ascendant and made honesty as hard to practice in your profession as in mine. (Laughter.)

Now, honor is something a man owes himself. At Cold Harbor there were three men of my regiment wounded and lying out between the lines. There was not a question of honesty, but Sergeant Bates came up to the Captain commanding the regiment and said "My messmate is lying over there and I hear him crying for water." If I were in his place I know he would answer my call, and Captain I want permission to take some provisions to these men out there between the lines." The Captain answered that it was certain death to do so and by doing so he was taking his life in his hands. He said "No matter, I will go." Two other men jumped up and said "We will go with you." Those men went out and carried stimulants and food to their wounded comrades. Two of them were shot dead, and the other was wounded. What do you call that? I call it honor. That is something a man owes himself. Honor is a thing that concerns you and me as an individual soul. Honesty is a thing that requires my fair treatment of you. Honor may exist without honesty. A French nobleman may do a disgraceful thing, deserving capital punishment, but you never can take him to the guillotine. He is educated to a sense of honor that will lead him to take his own life first. There is a feeling of honor that prompts a man to do things the world never knows of. But honesty is a thing that concerns the relations between man and man. What ever I do and what ever you do, the relations between us should be guided by honesty. There was a man who lectured once on the necessity of wealth and he told how he admired the precious jewels provided by nature and beautified by man, and how he often carried two or three in his pocket so that he could take them out and look at them and admire them. There are two jewels that you and I should carry about us and never cease to look at—honor and honesty. This world I am afraid with its combinations, its competitions and its rivalries in every department in human life is getting to be less honest than it used to be. I trust that in this jewelers' association as time goes by and this fifteenth anniversary passes on to the sixteenth and even to the one hundredth, honor and honesty shall be the immediate jewels of your sales, that eighteen carat shall be in all your gold, that diamonds shall flash without flaw, and you and your business in this world shall be all that is fair and grand in human life. You have embellished and adorned, you have given us beauty and God himself who plants the violet in the rock far from the eyes of man, is in favor of the jewelers work as much as the toil of the laborer in his plain way for his daily bread and butter. No men have done more to develop and further human progress and advance all the arts of human life than the jeweler by his handicraft, his genius and his skill. It has already been said that the trade of the jeweler began before history was written. He antedates chronology. He made for Egyptian Pharaohs and Jewish Kings, for Roman

Emperors, for the peasant and for the Queen of England, the crown on the head and the ring on the finger. That crown and that ring symbolize the trade that has come down through the ages to adorn human life and enlarge and beautify the world. Gentlemen, prosper for ever and may you maintain eighteen carats in all your gold and a diamond without flaw, and no pinch back, no sham, no flaw in any thing you do. (Applause.)

THE PRESIDENT: Gentleman, the next regular toast is that which Rip Van Winkle used to give:

"Here is to His Very Good Health, and His Family's Good Health: May He Live Long and Prosper."

Gentlemen: I have the honor to give you the good health of General W. T. Sherman.

General Sherman was received with great applause, while the band played "Marching through Georgia."

ADDRESS OF GENERAL WILLIAM T. SHERMAN.

Mr. President and Gentlemen of the New York Jewellers' Association: Six years ago, by the law of the land, I was retired from active service, and from that time I supposed I would be exempt from these calls upon me. I have been present at three of your meetings, this being the third, and this is the third time I have been in this very hall during the week. If this is the leisure you are going to give old soldiers seeking quiet and retirement, God bless them, that is all I can say.

Last summer I was invited to go to Denver on the Fourth of July, and it was in the letter very courteously explained that I was expected to say something. I declined with a pretty strong emphasis on the "No," unless I should be allowed to take with me some person to do the talking. Well, they at once granted me that privilege, saying "Certainly; bring any one whom you please." So I cast around and saw my friend Joseph Choate, whom you all know, and said: "Let's go to Denver; they will pay all the expenses. We will have a car to ourselves and have a good time." Well, he said he had some business that required immediate attention, and he couldn't go, but he was very sorry for it indeed that he could not go, but he gave me the name of a young man by the name of Guthrie, a partner of Clarence Seward, and I thought of Swain, who lost his leg down in North Carolina. So I addressed them notes and they accepted, and I had two good New York lawyers to do the talking. We went out, and on the first occasion I suppose there must have been from twelve to sixteen thousand people present. By cunning, and by the assistance of the president, I put forward my representative lawyers to do the talking, and each made a good speech. Well, when they were through, then they called for Uncle Billy. Well, do you know I have a good many hard nephews; my nephews call upon me for any and every service. One fellow said: "Oh, Uncle Billy, give us a speech." "But," said I, "I have got nothing to say. General Swaine spoke for me, and so did Mr. Guthrie; they both made good speeches, and I have nothing to say." Then they said, "Well, Uncle Billy, say nothing, then." So, gentlemen, I am here before you to-night under a promise to say nothing. General Porter has gone ahead of me, and he has said all that could be said on his branch of the subject, and Dr. Paxton the same, and it leaves me simply to thank you for the privilege and honor of being here to-night.

It is true I am an old Californian. I saw the first specimen of gold, not as it was taken from the earth, but after it was taken. Hundreds and hundreds of intelligent men had ridden over that very ground and found no trace of gold. The Mexicans had occupied it for one hundred years, and they are a gold-seeking race, but they had not discovered gold; and yet, by a marvelous accident, a man who was a "loco," as they call it out there—not exactly insane, perhaps—discovered gold at "Suter's Mill," and from that time to this that little event has worked a wonderful change all over the earth's surface. You are too young—nearly all the faces I look into now are too young—to remember those early days. I myself have seen gold grow up to tens of thousands; \$70,000 a year they used to take out, and I, a banker, subsequently sent about half a million a month to this metropolitan city. Therefore, I can speak for gold and silver which is applied to the arts by you, gentlemen, and transported to all parts of the earth to ornament a foreign life and make it better and sweeter and lovelier than it was of old.

The other day I was summoned to the dressing-room of a bride decked in all her finery, and she was beautiful in the extreme. I am not going to tell you any names. Her husband was waiting for her down at the church, and she wanted to know if she looked handsome. My goodness, she did; and while I was admiring that beautiful face and form and figure, she called my attention to a bright diamond folded together in a beautiful group, with a veil which covered her person, and still to another group of diamonds, and I thought they were nothing, yet they did set her off. And she wanted to know whether her intended husband wouldn't think them beautiful. I told her yes, he might look at them, but I didn't suppose he would. She herself was beautiful, and that was all that he was after. Yet, that decoration made her transcendently beautiful, and I suppose Tiffany furnished the diamonds.

I look at the silver before me, which I have seen at Tiffany's store many and many times, and which took the prizes among the manufactured silver in Paris.

Now, gentlemen, are you aware of the toil and labor and hardship necessary to get that silver out of the earth? You go to Denver, or even to St. Louis or Omaha, and you will see a pile of dirt there as offensive to the eye as any pile of plastering which you may see upon the street, and the man will tell you that it is worth a half million of dollars. Well, you wouldn't give a half cent for it, by judging by the eye—at least, I wouldn't. I couldn't see any silver, and he couldn't, but he knew it from experience. Now, that is taken first and roasted. Then it is put into a furnace and melted until it is just as liquid as that wine in my cup. They draw off the slag, and there are men who are so skillful that they can tell by the foam on the surface just when they come to the silver. After they have drawn off the slag and let it get cold, they melt it again, and so continue for a week. At the end of the week there is a slight film at the bottom, and after the slag is drawn off and cast aside as empty dross, the little silver is run into a mould called a map. Then it is ground up, and looks as black as your hat—if you wear a black hat—and is put into great pots, and by means of some sulphuric acid they dissolve out the silver, leaving the lead still in solution. That is passed into long troughs, and goes into other tubs of the same shape and form, full of plates of

copper, and the silver crystalizes on the face of that copper and looks as though it were frosty.

Now, your task begins where the labor ceases. As General Porter, and also my friend on the right, Dr. Paxton, have both said, you are the artists; the others are the laborers. They get the silver out of the ground, and you reduce it to forms giving light and beauty and encouraging virtue, and encouraging all of the better qualities of the human soul. Yes, gentlemen, you are artists in the very highest sense, and in that sense I am always pleased to meet you. I hope to meet you again. And if the time does come in the future when I may come and sit and listen to the words of others, I presume it will be much more pleasing than when I am expected to say something. I would rather have it as my Western friend put it: "Well, then, Uncle Billy, say nothing." (Applause and three cheers and a tiger.)

The President—There has been a good deal said here incidentally to-night as to the art of the jewelry trade, and in as much as the speaking seems to run in that direction, we will have a regular toast of it. I have the pleasure of giving the toast:

"The Jewelry Trade Coupled with Literature, Science and Art."

And I will call on the Rev. A. J. F. Behrends, of Brooklyn, to respond.

Dr. Behrends spoke as follows:

ADDRESS OF THE REV. A. J. F. BEHREND'S.

Mr. President and Gentlemen of the New York Jewelers' Association:—I have come to this crystal feast with a very profound appreciation of the shrewdness of the members of the New York Jewelers' Association. It does not seem to me, gentlemen, that you need any instruction on the subject of art, for I have been inveigled into my present position by methods which it seems to me are the very embodiment of the highest conceivable artistic cunning. I do not know that it was so intended, but still that only makes it more remarkable, as showing that you are shrewd by nature without any assistance from grace. I did not receive my invitation to this banquet by mail. It was placed in my hands personally by a messenger, whose name I found afterward as being one of the members of the Committee of Arrangements. I want to say for him that he did his work with admirable tact and delicacy. He talked about the good dinner we were going to have here. He told me all about the fine speeches that I might be expected to listen to, and when he left, I made up my mind that this world was not quite as bad as I had been disposed to think it was. Really I felt that such disinterestedness of affection as he showed toward me on that evening entitled him to be canonized as a saint right away. Well, I thought the matter over a day or two, and finally made up my mind that I might be in time to send a note accepting an invitation to this jewelers' banquet. I did so, and it was not long before I had an electric shock which went all through me, from the top of my head to the soles of my feet, in the shape of a note asking me to reply to this toast which has just been read, and I cannot undertake to describe my feelings. I did not know what to think. I was dumb with amazement and bewildered beyond all possible expression. I did not know what it meant. I had been through a rather strange experience just before that. Only a few weeks before that I had been on the same platform with General Sherman. I sawed the air on that occasion, and bellowed until my throat was sore—and I remained hoarse for a week—while the cannon roared and the brass band played, and the drums kept up their beating, and I wondered what I had done that I should merit a second exhibition like this.

I do not know just what your grievance is against me. I want to know what I have done that is out of the way. I am perfectly well aware that there are none of you here to-night that will ever get rich through my trade. I am not in a position to buy your gold or your jewelry, but I do not think a man ought to be persecuted because he is poor. Well, gentlemen, I think it is really to my credit that I do not get mad. I think that it is a sign that there is a little grace left in me. To tell the truth, I did not even send for an interviewer in order that I might give expression to my indignation through the columns of the press. I will go further and say that I grinned. I laughed right out. I saw that you had tripped me; you had outwitted me, and you had done it in such a way as to command my profoundest admiration. Now I presume very likely that this committee of arrangements knew very well that I was a timid and a modest man, that I lived in the suburbs of the City of New York, that it would not do to go at me hammer and tongs, because I suppose they were well enough acquainted with me to believe that if they did that sort of business, I would make a hasty retreat, and I can assure you that they were not far out of the way, for I am inclined to think that I should have found some plea why I should not be present to-night, if I had been informed that I should be expected to pay for my dinner by making a speech. But now that the ice is broken, I do not know but that I am ready to offer myself for any number of engagements in the future on like occasions.

You know a preacher always has the liberty of introducing his subject in any way that he chooses. I have consumed about five minutes in my introduction. I was always told in the seminary that a sermon ought to be just nine times as long as the introduction. It will take more time than that to cover the subject that has been given to me to-night, but I do not propose to apply the mathematical rule very strictly. The trouble is that I am not in a very good condition to make a speech anyhow. I have been looking at General Sherman all the evening, and have a sort of sympathy for him because I saw Dr. Paxton was pounding his speech into him all the time, and then my friend here, who is to follow me, Judge Hawes, has kept me busy drawing upon my resources between the courses. Well, what with sympathy for the retired Major General and a constant attempt to enlighten my friend on the left on the subject of jurisprudence, I am pretty well shaken to pieces. I do not want to attach his speech, because I want to leave him with all the benefit of the information that I have given him in the course of the evening.

It is a hard subject that has been given me to talk about—"Art, Science and Literature." Well, I know very little about literature. I know less about science, and I do not know anything about art at all. I am inclined to think that if I were to give expression to my views upon the subject of art, that you would be inclined to class me with the Philistine from the country, who is said to have looked at the Angelus of Millet, and to have remarked that he did not hear any bells ringing. He did not see anything on the canvas but what looked like two deformed individuals looking for potato bugs. The fact is, that the old masters never did inter-

est me very greatly. I always got away from St. Sebastian just as quickly as I could, for I do not believe any mortal man ever had a dozen arrows sticking in him, and then retained such a peaceful expression. At all events, I never envied him. I was perfectly content that he should be where he was, and I should be where I was. I said I did not know anything about art, and I do not. So I hardly know what to say upon that subject. I know very little of science either, and hardly anything of literature. There is one thing that occurred to me to-night. I have been told that I could take my text, for all clergymen are allowed to do that, and it seems to me that the twenty-first chapter in the book of Revelations ought to be a chapter very dear to the heart of every jeweler—"Streets of gold, gates of pearl and walls of jasper." I presume you are all anxious to get to Heaven. I have been told here to-night by a gentleman who ought to be well informed that jewelers do not live very long. I suppose the reason is that they want to get above where the stock is more abundant than it is here, and where they do not have to go through so much hard work, as General Sherman has described, to get precious metal. All the gentlemen that have preceded me have really taken my subject to talk about when they have talked in a serious way, and I might leave it there. But I want to follow out what they have said by saying that I heartily agree with everything that they have said. The love of the beautiful is a divine inspiration, and when art joins hands with truth and with love for serving humanity, there can be no nobler work in which any man can possibly be engaged.

I have known one who passed from wealth to poverty, losing everything she had in the world, and compelled to earn her daily bread with her own hands. A child of wealth brought up under the most luxurious circumstances, and yet not too proud notwithstanding that she had to earn her bread with the hard work of her own fingers and by the sweat of her own brow. Almost everything that she had was pawned or sold. But there were a dozen silver spoons and forks that she would never part with. She kept them in her deepest poverty, because she said that in her own home not a morsel of food should pass her lips until it had been transfigured by the gleaming metal. You may call that sentiment, if you please. I say that kind of sentiment is needed in this world. I say that kind of sentiment gives charm to life, and that it lends a transfiguring energy to deepest poverty. As I have exhausted the subject of art, I will take up science and literature the next time. [Applause.]

The President—Gentlemen, the next toast of the evening will be "*The Bench and the Bar: An Impartial Administration of Justice is the Basis of Good Government.*"

I have the honor of introducing and ask to respond to this toast the Honorable Granville P. Hawes.

Judge Hawes said:

ADDRESS OF HONORABLE GRANVILLE P. HAWES.

Mr. President and Gentlemen of the New York Jewelers' Association: You took occasion to refer to my profession in a very kindly way in your introduction. You also stated that the jewelers themselves, if the special occasion called for it, can be equally eloquent with any of us. Doubtless, you refer also to the fact that we can be eloquent provided a sufficient fee is forthcoming. Now I wish to say, referring to Dr. Paxton's remarks, that there is something, after all, which is better and deeper and nobler withal than the mere fact that we expect a compensation for our labor as jewelers or a fee as lawyers. And I am pleased on this occasion to note the fact that in your own business you have combined those elements and those characteristics that I have referred to. You live in a realm of art, and I do not believe that the quality of your productions is wholly dependent upon the compensation you receive. Following in the line of my friend, Dr. Behrends, touching upon your art and craft, I have come to believe that our wives and sweethearts are not altogether so beautiful and charming, for I think I have discovered the secret, that it is not the jewel that attracts, but it is quite the jeweler. You will remember that Rebecca went out of her way to meet Isaac at eventide, because when she met him she was presented with jewels. I suspect that all the time and money spent by our wives and sweethearts in the jewelers' stores are due to the gay, deceiving manner of the jeweler. In this same line I was induced to come here to-night, for I was invited by my friend Smith, who is always courteous and obliging. He referred to the beautiful ornaments that we see around us, and to the other attractions which make it the choicest dinner given here; and after I went through the same experience as Dr. Behrends I was asked by him, "Won't you say a few words at the dinner?" and here I am stalled up with all these star performers. But there is one great comfort to all of us that are deceived by you. This jewelry business is on the wane. (Laughter.) You do not begin to sell the jewelry that used to be in the olden time. The fact is that the wife of Calligula wore jewelry that was valued at over \$1,500,000. In the East the amount of jewelry was also enormous. The fact is, that you are just at the tail end of this business, and I am glad of it. (Laughter.) I would suggest that in order to keep up the business you had better go into futures. You could sell fifty rings where you sell one now, if you would only go into such a combination. If that were done we should not dread Christmas as we do now. Why, do you know that it is a matter of statistics, and I have got the matter right here, that on the Cotton Exchange, for instance, there are only six million bales of cotton that are grown in the South, and the crop in the Cotton Exchange is thirty-three million bales; and that in petroleum there are only thirty million barrels taken out of the earth, while two hundred million barrels are disposed of on the Exchange every year. There is one thing, however, to be said, that, gay deceivers as you are in life, you have always borne a high reputation for honesty and integrity. It is a fact, of which you are well aware, that there are but two guilds in the city of London to-day that occupy a position, which the Government has yielded to them, of assaying and stamping the product which they themselves make. You can't buy a piece of silver in the city of London that will not be valueless for sale unless it bears the stamp of the historic goldsmiths' guild. There is no parallel in the history of the world where the integrity and honesty of an association stand in public esteem any where near the association of which in this country you are the representatives.

But what is this toast? I had forgotten about it. The Bench and the Bar: An Impartial Administration of Justice is the Basis of Good Government.

In attempting to respond to this formidable toast, I feel very much as Artemus Ward did when the cannibals stood in front of him with their spears pointed at

William H. Atwater,

(Sole Agent.)

6 Warren St., **CLOCKS** New York.

E. N. Welch Mfg. Co.

Boston Clock Co.

NEW CATALOGUE Ready showing NEW LINE of this Company's well known make.



ELEGANT MOVEMENTS, JEWELLED. Fine Watch Escapements. Handsome Designs for the Mantel or Traveling

MARBLE, ONYX, WOOD, IRON, BRONZE AND GILDED CASES. OXIDIZED SILVER, BRASS AND NICKEL CASED NOVELTIES.

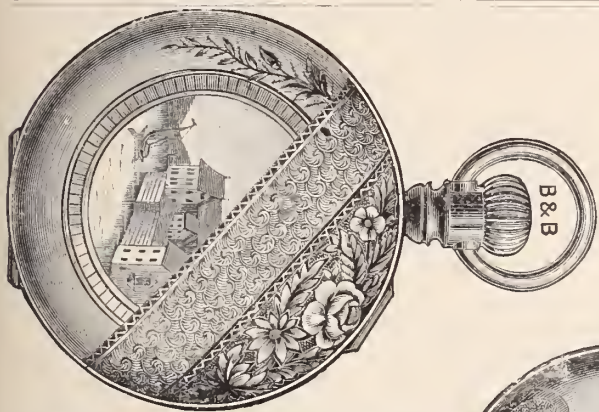

SUPERIOR IN QUALITY.

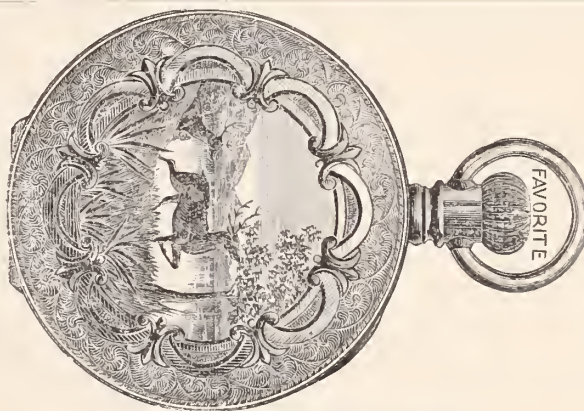

PEER, GEM FAVORITE and 'B. & B.'

BALTIMORE & BACON'S

CASES



WATCH

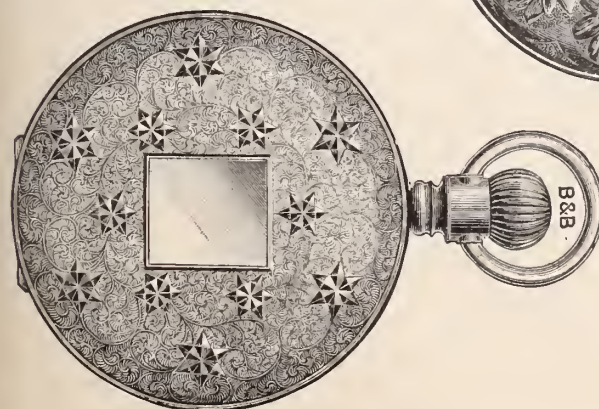

PERFECT IN FINISH AND DESIGN.

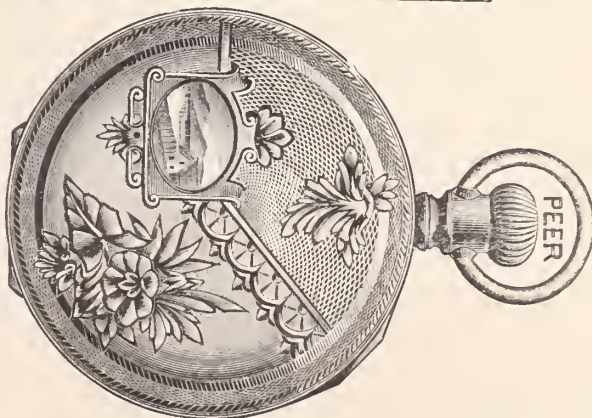

his heart, "Not dismayed, but considerably discouraged." The Bench and the Bar—that is all well enough, but the balance, The Impartial Administration of Justice is the Basis of Good Government. This is the discouraging element, for, in my judgment, good government has its source in more potential forces than the mere direction of its machinery, and the nation that relies upon the administration of its laws, however impartial and however worthy, will come to grief sooner or later. It is possible that we are coming to place too much confidence in the mere machinery of the Government and too little upon the essential conditions of the Government itself. The Bench and the Bar, as representatives of the law in the Government, are no better and no worse than the governed. Ruskin says that there are five great intellectual professions relating to daily necessities of life—the soldiers to defend it, the pastors to teach it, the physicians to keep it in health, the lawyers to enforce justice in it, and the merchants to provide for it. Now, the merchant is as integral and as essential a part of the government as the lawyer or the judge. Now, law itself is nothing but an unwritten contract, which has become established by common consent over a long period of time, and has thus become a rule of life. It is said by Fisher Ames that if there could be a resurrection at the foot of the gallows—if convicted criminals could be summoned from the buried dead and called to life again, and be permitted to form a society by themselves, they would soon be obliged to make justice—that justice of which they had been the victims, the fundamental rule of their social states, stronger than gravitation, stealthier than the growth of a forest, are the forces that go to make the laws we live under, and which constitute good government. Now, this is the fact in regard to what we call justice and what we call law. The Bench and the Bar do not make it or control it or have anything to do with it except merely to enforce it, as I have said. Now, my object in referring to this matter in this way is to urge upon you, as merchants and manufacturers, to trust less to the judicial machinery of the Government for its purification.

While judges in the main are upright, honest and honorable, yet it is a fact that in some cases they are influenced by the atmosphere about, and occasionally more are in lines of popular sentiment and newspaper clamor. So you want but little of the bench or even of the legislature to establish good government, and worst of all to rely upon them, and right here, in my judgment, is the secret of all our trouble.

There is no question in my mind, or in the minds of any of you gentlemen, that there is a fast growing sentiment that government should be doing more than it has been doing—that it should supervise our affairs and remedy our acknowledged evils. The pendulum is swinging back again to the old theory of the duties of government as it existed two or three hundred years ago. Matters press upon us, troubles overcome us, and our first thought is to fly to the government for relief. In the opinion of many, governments should administer charity, should adjust the price of food, should regulate railways, should prescribe the hours of labor, provide public libraries, should determine the amount of money which should be put into any one enterprise, and in short, should regulate an endless lot of things. This idea of a parental form of government has been growing upon us within the last fifteen years, and, in my judgment, this widening sentiment is one of the most menacing dangers to our future as a nation.

Any people, and especially any commercial people, that is so weak as to be compelled to continuously call upon the government to regulate its own domestic life has within itself the seeds of dissolution. Security to life and property is all that we are entitled to under the law and is all we need if we have any self-reliance or any manhood. This was all that the founders of this government intended to give us—security to pursue our happiness in our own way as best we could, protecting us in the blessing of living and in the enjoyment of our property. They knew full well what evils a parental form of government would lead to, for it had been exemplified in the Old World. What a pitiful display is this attempt to regulate labor as a government duty, as though the natural laws of trade and of supply and demand were wholly insufficient. What a commentary upon our character as a commercial and a business people. So the sooner we learn that the best government is that which governs the least, the better it will be for us. Cause and effect follow one another with swift feet. If a trust is not a good thing it will soon cease to be a trust. If oleomargarine is not good to eat it will soon be found out, and you cannot sell it. So this everlasting meddling of the government in all our affairs should be stopped and at once. The temporary relief that it will give is like the fatal anesthetic which is given a patient who awakens weaker than before, until he ceases to wake at all. We have prospered well as a people under the simple theory of government which our fathers gave us a little over a century ago, namely, security for life and property, nothing more, nothing less. You must arrange all other things yourself, they told us. In fact, we have made money by not allowing the government to bother us in any of our affairs.

At the time of the last census, 1880, the wealth of the United States was \$43,642,000—more than enough to buy the Russian and Turkish Empires, the Kingdoms of Sweden and Norway, Denmark and Italy, together with Australia, South America—in lands, mines, cities, palaces, factories, ships, flocks, herds, jewels, moneys, thrones, sceptres, diadems and all the entire possession of 177,000,000 people. The facts I obtain from a very able essay by the Rev. Dr. Strong, and I have every reason to believe them authentic. Great Britain is by far the wealthiest nation of the Old World and our wealth exceeded hers by \$276,000,000. He calls attention to the fact that European wealth represents the accumulation of many centuries, while the greater part of ours has been created in twenty years. During these twenty years we lost a million producers by the war and \$1,250,000,000 in the estimated value of slave property which disappeared from the assets of the nation. But, notwithstanding all this our wealth during these twenty years increased \$27,452,000,000—\$10,000,000 more than the entire wealth of the Empire of Russia, to be divided between 82,000,000 people. This was the wealth after supporting the best fed people in the world. To the wealth of 1870 were added, during the next ten years, 19,587,000,000, an average of \$6,257,000 every week day for the period.

What the next census will show, no man can say, but all will agree that it will soon surpass the entire wealth of Europe combined, unless our energies are sapped and our strength weakened by this movement to involve us in a parental government. It may well be said that various fortunate circumstances have brought about this result, but every student of political economy knows that the form and system of government has more to do with the prosperity of a people than the fruitfulness of its soil or the salubrity of its climate. We have had not only freedom of thought, religion, educational and political, but what in my judgment is more—we have had freedom of business action and business conduct without restriction and without interference from the government in our affairs in any effort to control our commercial life under the guise of police authority.

After all, gentlemen, good government is not an external force. The mere

authority of the State counts for little—the law-abiding individual spirit counts for much. What can the law do in the State of Kentucky if one man calls another a liar? So the spirit that pervades a community—subtle as the air it may be—that it is which determines the basis of good government.

It is said that the shield of Phidias was so inwrought with the name of its artificer, that if broken, every separate fragment would retain the immortal appellation. Such is the character of good government as it is found embedded in the character of a people—its power is from within and not from without, and a business community counts no help from the government in the conduct of its affairs, and if it is true to itself, it will have none, however much politicians may desire it. Time and experience will demonstrate it—the stars in their courses fight for it.

Now, however all these things be, I suspect that the great educational forces of business will make these things even, and that good government will be the reward of business honorably done and of business lives worthily lived. [Applause.]

The President—Gentlemen, the next toast of the evening was to have been "Our Country," and we expected to have had with us the Honorable Chauncey M. Depew. We had hoped that he would come until four o'clock yesterday afternoon, when he sent up word that he was called out of town and would not be able to be present.

We have had the pleasure of listening to our uncle to-night, but there is one with us who bears a still close relationship to us all, who will respond to the toast

"Citizenship: Its Sentiments, Duties and Obligations."

And I call upon our godfather, the Honorable Noah Davis, to respond.

Ex-Judge Davis spoke as follows:

ADDRESS OF HON. NOAH DAVIS.

Mr. President and Gentlemen of the New York Jewelers' Association:—I know by experience that the last thing that the jeweler wants to hear, after he has eaten and drank for five mortal hours at this table, is a talk from his godfather, and I shall, therefore, not occupy your time with much of a speech. When my learned and reverend friend on my right, Dr. Paxton, turned State's evidence and told you something that I told him, and which he had not discovered about the good looks of this audience, he made in response the remark that after all he did not think you could beat his congregation, and then he proceeded as clergymen ordinarily do, to make a long speech upon a text without alluding to the text; he just gave it at the close. I recollect a little while ago being at a friend's house, whose family attended, I think, Dr. Paxton's services, and after returning from church (it was on Sunday), we sat at the table. The lady was very eloquent in praise of the sermon she had heard. Finally I asked her where the text was. "Well," said she, after thinking it all over, "I declare that has escaped me." The little boy who had been to church with her sat at the table, and I said to him, "Do you know where the text was?" "Yes," said he, "I know very well where the text was; it was at the tail end of the sermon." The words were "Awake, Thou that Sleepest," and, said he, "we all got up and went home." Now I don't know that the rule is to be followed with all the speakers to-night. I wish it had been — of not sticking to the text at all; but, as your god-father, I will stand here long enough, at least, to give my thanks for the honor you do me in calling me your god-father, at the same time that you feed me. I hardly think I could stand it on any other occasion. A god-father—what is it? Whatever a god-father may be, in my humble judgment, it is an honor to be one, provided it be a compliment. I do not know that I shall be able to be here on another of these anniversary occasions, but I have firmly resolved that if I am not, my last dying charge to my family shall be to see to it that it shall be engraved on my tombstone "He ate all the jewelers' dinners." [Applause.]

I had a text, and you heard it. It is citizenship. I was ready in the early part of the evening to come down to you with a speech on that subject that would drive out of your heads all the flattery of jewelry that has been put in. I never heard a body of men praised up as you have been here to-night, because you are jewelers. It reminded me of an incident that occurred in court some years ago in northern New York. There were three or four lawyers in the case, and one of them was a gentleman of very great distinction at the time, and all the other lawyers were chiefly employed in praising him, in telling what an amount of knowledge he possessed, what great virtues in the way of eloquence and skill, and all that sort of thing, and when he came to talk to the jury, I recollect well how he opened. He said: "Gentlemen, I have had a great deal of experience in this life. I have been subjected to many afflictions. I have had illness and death in my family. I have had all sorts of calamities; but of all things on earth, God deliver me from a deluge of soft soap."

I cannot talk about citizenship here to-night, and yet I would like to: The citizenship of America is something which, when rightly considered, the brightest jewel ever dug from the deepest mine of Golconda is poor and inglorious compared with it, and at this hour, as I could be able to show you if time permitted, there is not in the whole circle of the earth one jewel so glorious in the diadem of nationality as the citizenship of the United States of America. To prove that would take but a little time, but I shall not enter upon that proof. I shall start off and end simply by saying that the best room for best citizenship is in the virtues, the conduct, the honor of the land. Our citizens may be divided into a great number of classes. Some of them holding the highest rank are the best evidences on earth of the glorious character which man is capable of attaining. Let me for a single moment dwell upon this idea. What has been within your recollections the highest proof of the grandest, of the best citizenship of America. I speak now of the dead. In view of all, one name transcendent above all others, springing from poverty, reared in the midst of indigence, grand in his character, even in humble life, and yet so humble that those traits which made him grand were not discovered at all. And the hour came that proved the magnificent nature with which God had crowned him. I speak of General Grant. What sublimer character, what nobler, purer nature; what tenderer, gentler, nobler being, ever proved the virtues of manhood under the institutions of America? But he is gone, leaving that memory to us which we can only cherish with proud loss, which we shall regard as precious to the longest day of our lives.

Another character comes fresh to me as a citizen of our common country of whom we may well be proud. I do not know, but I believe he was born on American soil of Irish parents. In humbler life, a grade from which we would not expect to see the true greatness of manhood, noble, exalted, triumphant. I speak of Sheridan. Taken from the hearth stone of poverty, humble, scarcely through his childhood, having no means of subsistence, except those which he earned with his own hands, growing finally to an age when this country could place him in her military school, and when the hour came for service to be rendered to her, what height of citizenship and its true glory did not that young Irishman attain? We have only the light of his example trailing behind him like a planet's glory after it has disappeared from our sight.

And then we have one other of the same class of men, who, in the same line, has achieved fame, renown, honor, glory, and is now in old age among us and surrounded with a halo of human love, such as no other human being enjoys [cheers for Sherman]. With these three bright noble examples of American citizenship, and without going into the topic any further, I shall close. We are proud that one of them lives. We are glad to hail him on all occasions, here and everywhere, and may God spare his life to be an example to the youth of America of that courage, devotion, truth, humility, and yet that pride which crowns manhood with its greatest worth—his capability. [Applause.]

The President: Our toasts have suffered such hard usage to-night that I hardly have the confidence to stand here and give out another one. And yet there is a sentiment attached to this idea:

"The Press; the Leader and Reflector of Public Opinion."

I will call upon the Hon. Isaac H. Bailey to respond to the toast.

Mr. Bailey spoke as follows:

ADDRESS OF THE HON. ISAAC H. BAILEY.

Mr. President and Gentlemen of the New York Jewelers' Association: I feel extremely happy to be called upon at this late hour of the evening, because there are not so many present as there were earlier in the evening and if there were any reporters present or if there was any danger of any of you paying any attention to what I say, I might not have so much courage to speak. I am an omnivorous reader of newspapers, and I am therefore prepared to say something about them, and I have to say here in the interests of truth what I hope no newspaper man will ever hear, because it is extremely dangerous to come in contact with a newspaper man. But it is satisfactory once in a while to say what every man in the community thinks about the newspapers. They are great, they are wonderful instruments of education and misinformation. They disseminate a little truth and a good deal of falsehood. They perpetrate libels upon the people with perfect impunity and with a recklessness which is extraordinary, and presupposes the idea that conscience was generally left out of the editorial character. I am sorry to say but I believe it is true, and I believe that every man who hears it unless he is an editor, knows it is true, the newspapers have been so full of the disposition to find fault with every thing and every body, that they have conveyed to the people of this country the idea that all public men pretty much, or the majority of them, are men of doubtful virtue, and that it is entirely unfortunate for the American public that the newspapers are not given an arbitrary power for the purpose of ruling and governing the entire United States.

General Grant on one occasion made a speech, I think one of the best speeches in response to the toast of the Press that I ever heard, in which he said that the newspaper men seemed to have a general idea that it was their vocation to run the government, but he differed some what from them when he was President, having the impression that he was elected to do that himself, and thereupon the newspaper men made assaults upon him as you remember, and for about one year before his re-election in 1872, I think he was the object of more abuse and more calumny than had ever been visited upon any public man before. Happily it did not produce the slightest effect upon the public mind, except the effect of calling forth from them such a magnificent protest as silenced for a time the editors who had assailed him by their abuse. I think the answer of the American people to the libels of the newspapers in 1872 was one of the most magnificent demonstrations of public opinion and one of the greatest proofs that the American people are not susceptible of being humbugged by lies that has ever been known to our people. Now we all feel toward the newspapers a certain sense of anxiety not to get into their clutches, because they can strike at a man 365 times a year, and do not hesitate to do it, what ever the merits of the case may be. There is an old story of a shoemaker who went around making shoes for families and he visited a family with his kit and stayed there a week or two and made up the shoes for the family. This shoemaker being of a convivial turn of mind, was in the habit of going in the evening to the neighboring ale house. One night he stayed a little longer than he ought to have done and he found the door locked and a dog standing guard at the door. He was in an unfortunate position, for whenever he got as far as the door the dog would strike at him, so he began to say: "Good dog, nice dog, clever dog" and whistle coaxingly to him. But in his mind he said: "Oh if I had a club and could get in that door how I would knock that dog." So we say to the newspapers. Palladiums of our liberty, glorious illustration of the virtue of the people, but oh! those wretched newspapers, how they do lie. I have read and you have read within the last five weeks, deliberate and base accusations made against as pure a man as ever lived in the city of New York, and they were published without anybody ever uttering a protest. Suppose the friends of the man had gone to the editor and remonstrated? What would have been the result? They would have gone on attacking him more savagely than ever. All that you can do is to bear the abuse. Is there no remedy? Why I read in a morning paper of this city to-day, a paper of immense circulation, no less than seven distinct attacks upon rich men of New York because they had not subscribed to the fund for the Fair which is to be held in New York, and I discover that the rich men are the objects of especial attack by newspapers, and that it is becoming a pretty dangerous thing for a man to be a rich man unless perfectly willing to be roundly and rankly abused.

We have read in the volume which may be familiar to some of you, the statement that it is difficult for a rich man to enter the kingdom of heaven, but it is evidently unfortunate for a rich man to occupy a place on earth. I do not know what these rich men have deserved, having no chance of being at all familiar with their methods. I do not know but that the rich men are very bad. I suppose that our friend Dr. Paxton would be as good authority on the character of rich men as any one here, and I will say in defense of the newspapers, that alluding to the popular

judgment, the Doctor has not been entirely successful, though it is not his fault, in converting all his congregation to such methods as are respected in the community. But I do not think that it is quite a crime to be a rich man and I hope it is not going to be considered a crime. But if you read the newspapers and believe them, which you probably do, I do not believe you will come to the conclusion that rich men are such a remarkably privileged class of people after all. For as rich as they are they are very likely some of these days to find themselves libeled in the newspapers.

But I think that where the newspaper gets its best hold is in the administration of justice. There it rules the Court, it instructs the judge and bulldozes the jury. If a verdict is found against their will they insist that there is something wrong with the prosecuting attorney. They go after him in a most savage manner and you almost come to the conclusion that the government is a matter which they ought to attend to, that the jurisprudence of the country, the civil and especially the criminal ought to be turned entirely over to them. Now, gentlemen, we cannot do without the newspaper, it is indispensable. Cannot we reform it? I felt some discouragement when Dr. Paxton said that honesty was on the decline. That is ecclesiastical testimony which of course we are bound to accept, but up to that moment I had believed that honesty was constantly increasing, and I had believed it more, perhaps from my association with jewelers than from any other reason whatever.

I have a great many beloved friends among the jewelers. Why they should be my friends is a mystery to me, because I have never done anything in the way of business with them, because they have never liked to accept my obligations. Whenever I want to see anything beautiful, I go into the shop of my friend, Mr. Smith, at 182 Broadway, who always receives me as courteously as if I wanted a \$125,000 diamond, and occasionally, perhaps, if he has something in the way of paste very cheap, I may purchase an article just to present to a friend who will accept it as genuine. That is not honesty, but a mild form of dishonesty, for Smith's paste, I am bound to say, looks so much like the actual diamond that I cannot tell them apart. Now, in the safe of my friend Tiffany, I have an \$80,000 diamond necklace. I do not have any trouble with it. I do not have any interest to pay on it. I am not in constant fear of burglars. Tiffany keeps it for me. When I want to go and see it I go, and the charge is nothing, and he says come again. Gentlemen, I believe that in all this world men are growing better, more honest, more upright, more noble, in all other departments except the newspaper kingdom. And, gentlemen, I think if we were a little freer in expressing our minds, and a little more vehement in our protests against every wrong that is done to our citizens through the types, we should ultimately rise up and make the newspaper press a recognizer of public opinion and a proper leader, instead of the conduit through which so much vituperation flows. [Applause.]

The President: I will ask your attention to the next toast:

"The City of New York."

We have with us to-night a gentleman who knows all about the city of New York, and knowing that the city of New York was originally settled by the Dutch he has been over to the country of the Dutch to find out all about the people who were the first settlers in New York. I have the pleasure of calling upon Mr. Robert B. Roosevelt to respond to this toast:

ADDRESS OF ROBERT B. ROOSEVELT.

Mr. President and Gentlemen of the New York Jewelers' Association: Looking at this watch presented to me this evening as a little tribute of your esteem, and which is a very worthy specimen of the jewelers art, I observed that it records the time at a quarter past twelve o'clock. Inside of the watch there is a good deal in the way of sweet meats; on the outside of it I am afraid there is some prevarication of truth. It does not altogether agree with my own time, but at the same time they are so near together that I shall not detain you very long. Whenever I speak about the city of New York as I have been called upon to do several times, I generally make a preliminary statement in reference to my age, otherwise I might be put down as among the Methuselahs of modern times, for I have seen New York grow more than you could readily imagine, having been born in Cortlandt street, which was way up-town in those days, and most of my friends living upon Ewing Green or Greenwich street. I have seen New York slowly advance until after she had built the first house on the block bounded by Thirteenth and Fourteenth streets and Broadway, which has since been torn down, and the locality has been occupied for business purposes and sewing machines, it has slowly gone on until now it has reached the Harlem River seven or eight miles from where it started. It has grown enormously in size since that time and equally in wealth.

When I was a youngster about eighteen or nineteen years of age, I was standing one day listening to the wealthiest men of the city of New York discussing wealth. They were, with the exception of Mr. Astor, who even then stood prominently above all others, the representatives of the very wealthiest people of New York, and one of them remarked to the other "a hundred thousand dollars is an immense fortune—a man who has an income of six thousand dollars clear is a very rich man." Judge Hawes very kindly acquainted us with some very valuable statistics and you can imagine the growth of our city from the time when that conversation took place until the present time when it represents a thousand billion trillion, quadrillion, whatever you please of money.

But the city of New York, while it has grown enormously in size is growing immensely in activity. I do not know as it has proved to be so much beyond the times of our ancestors as I found them remaining on the other side of the water in The Hague. There are people there who imagine that every thing in Europe is superior to everything in America. I was never able to see it in that light and I was inclined to indulge in the American habit of boasting. Traveling in Europe wherever I might they would ask me if the hotels were not wonderful. I told them that nobody in Europe knew how to keep a hotel. They asked me whether the cooking was not delicious in comparison with the barbarous American cooking, and I said they did not have anything to cook. They did not have a canvas back duck, they did not know what a roast was or a fried oyster, and they did not have any terrapin.

Even in the matter of art I felt it my duty to purchase a quantity of old silver, and among them a lot of apostle spoons, as they call them, and apostle knives and forks, and all sorts of things. I went on buying and buying these things until I could not stand it any longer and I said to my people, "Let's go home

where we can get something handsome." I did not discover any point where Europe was so superior to America in the present day. And even in the matter of the press which my friend Bailey has referred to so eloquently and truthfully, I find they are lacking over there in the proper service of the press, and following the example of Judge Hawes I will read an extract from one of the Dutch newspapers, and you know the Dutch is one of the leading nations of Europe. [Mr. Roosevelt read an interesting item from one of the Dutch papers in Dutch.] It says that the diamonds are polished on a wheel, as you probably all know, which turns around a good many thousand times a minute. Then it goes on to say that the firm of Tiffany & Co. have discovered a diamond that was so hard that it could not be cut or polished with diamond wheels revolving at the rate of 28,000 times a minute, and that they put a pressure of forty pounds on the stone, which ordinarily only takes two pounds, and they kept that running one hundred days until a point in the circumference of the wheel had made three times the circumference of the earth, and yet the diamond was no more polished than when they began to polish, and Mr. Tiffany gave up the job and presented the diamond to the Academy of Science in New York. That I have no doubt is a piece of interesting news, especially to Mr. Tiffany himself, but this is a mere trifle and bagatelle in comparison with what the press of America can do, in which we see, day after day, and week after week, column upon column of statements in which there is not one word of truth. (Applause.)

The President said that the regular toasts having been finished and some allusion having been made during the evening to the Goldsmith's Guild of London, he would call upon Ex-President Dominick to state some of his experiences while abroad this year in connection with his visit to the Goldsmiths' Guild, where he understood, he had been very cordially received.

Mr. Dominick responded :

ADDRESS OF EX-PRESIDENT H. B. DOMINICK.

Mr. President and Fellow Members of the New York Jewelers' Association : I always supposed it was the duty of the President of the Association to make a speech on such an occasion and I supposed it was a privilege of an ex-president to keep silent, therefore I had no idea when I came here this evening that I would be called upon to say a word. Judge Hawes has said that he visited the Goldsmith's Hall in London and in reading statistics says that after discussing business they discussed what they should drink. It seems to me that we have struck upon a very unfortunate time to discuss what we should drink, for in the language of an American Poet : "The melancholy days have come, the saddest of the year, when it is a little too warm for whiskey straight and a little too cold for beer."

I have been asked by your president to speak of the courtesies I received at the hands of the members of the Goldsmiths' Hall of London. I was granted privileges that I believe are granted to none except the members of Goldsmiths' Hall, as being your president. I was taken into the office, the business office of Goldsmiths' Hall, where the assays are made, and I was shown their process, which is supposed to be very carefully guarded. They showed me how they took samples of all the silver that was made in London. Silver offices are established in all the manufacturing centers throughout England, and no silver is allowed to be sold throughout Great Britain that has not the Goldsmiths' stamp, the stamp of Goldsmiths' Hall, whether in London, Edinburgh, or wherever it may be.

I think we have been somewhat flattered to-night, and perhaps not without reason. We have been told that we do not need government supervision. Judge Hawes has told us that. We can stand by ourselves, and to-day, I think the proudest thing that the American goldsmith can say is that the stamp of the accredited houses is as good a guarantee of sterling as the Hall Mark of London. It is to the interest of every silversmith and of every jeweler to keep up that standard, and as a silversmith, I say decidedly that any silversmith in the country who dares to stamp his goods sterling unless they assay 925 fine, would be ruled out of the trade in less than thirty days, and his goods could not be made merchantable, and I think that is the best evidence that we do not need government control or supervision. To-day the silversmith stands as the one trade, preeminently ahead of all other silversmiths in all other countries. We now have an opportunity to enter into competition to take the Grand Prize in silver, and I may say that I believe truly and honestly the reason that the silversmiths can get the grand prize is because their raw material costs them no more than in any other country in the world, and the sooner that other trades recognize the fact that raw material must be made free to stimulate our manufacturers, strengthen our country and make our business more profitable, there will be a union of trades to stand hand in hand with the silver trade to demand by fair competition the grand prize all the world over. I thank God I can stand here to-night and declare that the American silversmith does not need the protection afforded by the Goldsmiths' Hall of London. (Applause.)

After wishing them good night, and saying that he hoped all present might meet together again in one year's time to celebrate the sixteenth anniversary of the Association, President Douglas dismissed the company.

bery & Co.; Benjamin F. Moore, B. F. Moore & Son; John C. Simmonds, Joseph F. Wakers; Albert H. Tyroler, A. C. Smith & Co., of New York City; and Michael F. Kennedy, Hibernia Fire Ins. Co., Charleston, S. C.; Patrick H. Kennedy, Robert Martin, Charleston, S. C.

The purpose and work of the Jewelers' and Tradesmen's Company manifests itself in the following letter:

NEWARK, N. J., Nov. 19, 1889.

Mr. Gilbert T. Woglom, President, and the Jewelers' and Tradesmen's Co.:

GENTLEMEN—I beg to acknowledge the receipt of your check on the United States Trust Company for twenty-four hundred and six 90-100 dollars (\$2,406.90), being in full for the benefit accruing to me as the beneficiary of my deceased husband, Henry Elcox, according to the terms of his membership.

I would also express my appreciation of your promptness, I having placed the proofs of his decease with you on the 13th inst., and receiving your check on this, the 19th inst. Yours very respectfully, ANNIE ELCOX

The two deaths which have occurred during the three years of existence and growth of this society, were of members holding each \$4,000 certificates. At the time of the death of the first the mortuary fund was of such volume as to produce 35 per centum of the certificate, while the holder of the second, as above shown, was paid over 60 per centum, this being due to the increase of membership in one year.

At the meeting of the Executive Committee on November 19, an assessment was ordered to be made on all the membership, current on the date of the death of Mr. Elcox, notices of which have been since mailed to the members.

The Gorham Co's Subscription Book.

On Nov. 7, E. Holbrook, treasurer of the Gorham Mfg Co, wrote to Mayor Grant saying that he had forwarded \$100,000 to the secretary of the Finance Committee of the New York Worlds' Fair Guaranty Fund of \$5,000,000, which he had collected by personal effort and expressed the opinion that had not the Central Park question been raised, he could have collected twice that amount. But that Mr. Holbrook's subscription book makes a most commendable showing will readily be perceived from the following list :

Table listing subscription amounts for various companies and individuals, including Gorham Mfg Co, Durand & Co, Ingersoll & Glenn, etc.

INDEPENDENT SUBSCRIPTIONS.

Tiffany & Co\$25,000 | Louis Strasburger..... \$1,000

*Jewelry or kindred house.

The Jewelers' and Tradesmen's Company.

During the current month the following additions were made to the roll of members: Charles E. Jenkins, Leroy W. Fairchild & Co.; Alfred Collier, M. B. Bryant & Co.; Oscar Astmann, Bonner & Eisler; Daniel C. Bauer, Leopold Greenstein; Charles Chedd, Gran-

Holiday Window Attractions.

PRACTICAL POINTS ON WINDOW DRESSING, WITH ILLUSTRATIONS OF SOME MODEL DISPLAYS.

HARBINGERS of the merry holidays are observed in the little groups of pedestrians now daily seen gathered about the show windows of the retail stores on our principal business thoroughfares, admiring and commenting upon the beauties of the articles displayed, fluttering from one window to another, casting an approving glance at this triumph of the milliner's skill, or a longing look at that *chef d'œuvre* of the goldsmith's art, keeping up meanwhile a gentle hubbub of conversation.

The fondness for jewelry which, to a greater or less degree, is innate in all our natures, the desire on everyone's part to bestow some holiday gift, combined with the peculiar fitness of jewelry for gifts, cause windows in which such articles are displayed to be specially favored by sightseers. But the observer soon perceives that the same interest is not excited by all jeweler's windows, for while one attracts crowds constantly another is totally ignored. The secret of this discrimination is soon apparent to the observer. It does not depend upon the size of the merchant's establishment or the popularity of his name, nor to any great extent upon the price of the goods displayed, though all these considerations may have their weight, but mainly upon the style or manner in which the articles are arranged within the window—the amount of time and study given to the art of window dressing.

The importance of this art in the retail business cannot be overestimated. Its successful achievement is undoubtedly a pretty good index of the prosperity of a house, and has been the foundation of many a man's fortune. Among the larger retail houses, especially in the dry goods line, these facts are thoroughly appreciated, and most of them employ special men whose sole occupation is the arranging of the goods in show cases and windows. These men are designated as "window dressers" and command large salaries. In the early morning or late in the evening, especially at this season, it is no uncommon sight to see two or three men within the windows of some large dry goods emporium arranging the goods, under the direction of another man, who stands on the sidewalk outside.

The latter is the window dresser, and is apt to be a man of artistic training and ability, who found the living afforded by the pursuit of pure art too precarious. Besides these regularly employed window dressers, there is another class of the profession consisting of men who are not attached to any one establishment, but attend to the dressing of the windows of whoever will employ them, having perhaps a half dozen firms on their list. These men also are, as a rule, artists, who find the career of window dressing far more remunerative than illustrating, sketching and painting. Though it may not be necessary for the ordinary retail jeweler to employ regularly a professional dresser, it would prove advantageous to his interests to either engage the services of some itinerant, or have, as one of the merchants whose window is illustrated in this article, a clerk who combines with other qualities a taste and artistic ability sufficient to set off the beauties of his wares in the window.

Looking to day at the show windows in the jewelry trade, and remembering what they were a decade or so ago, we cannot but be impressed with the vast improvement in attractive arrangement that has been made. Nevertheless, for some reason unknown to the reader, unless it be that strange conservatism that clings tenaciously to the trade and will not be shaken off, the jewelers do not seem to manifest the interest in this art that merchants in other lines of business do. Possessing as they do unrivalled opportunities, varied lines

of artistic goods, a force of young men, many of whom from the nature of their business must and do have genuine artistic tastes, this neglect is, we repeat, difficult of explanation.

Many passers-by may only gaze and admire to-day, but they are the purchasers of to-morrow; and is it not natural that they should resort to the houses whose displays have left upon their minds the most pleasing impression? And as admiration of an object begets a desire for its possession, how often have we seen the casual spectator, charmed by the beauties of some trinket in a window, enter the store if but to ask for its price.

Though much depends upon the nature of the stock and business, and the size and architectural structure of the window, there are numerous principles that govern the decorating of windows in general. Above all, do not commit the mistake of overcrowding, which does not mean that only a few objects should be displayed, for such is almost as fatal a mistake. Though quantity does not impress the spectator as quality and taste of arrangement, his interest must be kept alive by discovering new beauties in different objects. On

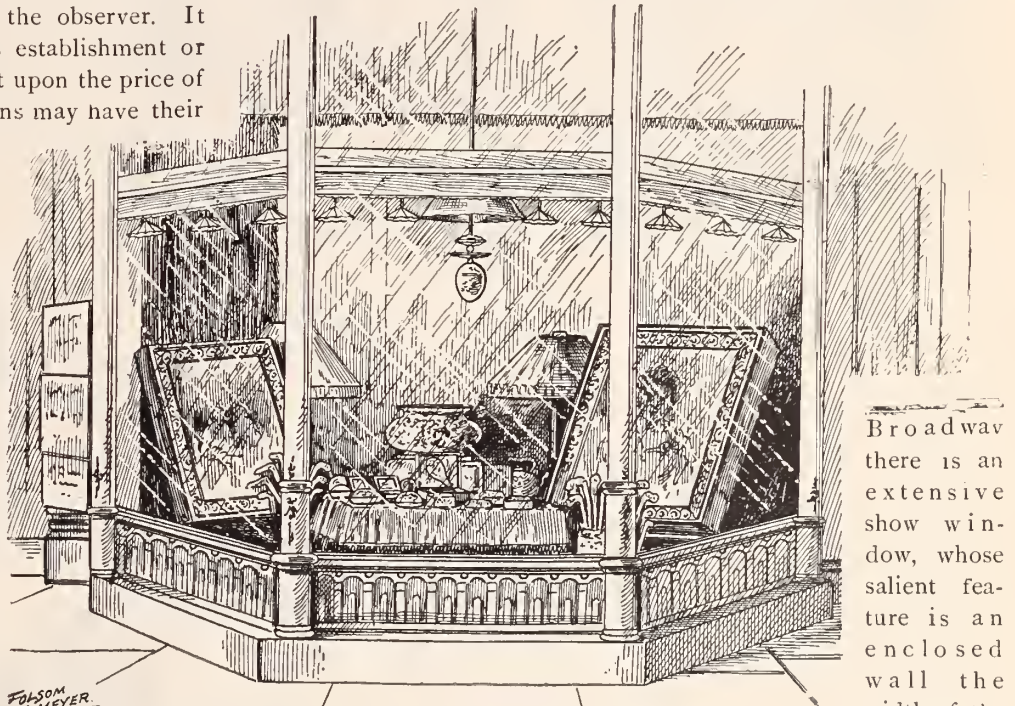

ARTISTIC GROUPING.—SIMPSON, HALL, MILLER & CO.

Broadway there is an extensive show window, whose salient feature is an enclosed wall the width of the window, literally covered

with a heterogeneous assortment of collar buttons, cuff buttons, ear rings, brooches, scarf pins, etc., on white cards, which attracts crowds of pedestrians by reason of the very profusion of the display without leaving a single well-defined impression upon their minds. No doubt many of the articles are really entitled to appreciation, but the sameness, the lavish quantity shown without art, without taste, create a painful sensation of bewilderment in the observer. And if you desire your stock to look other than cheap tinsel, never display the goods on cards, especially in the window.

Secondly, the display of the goods should be bold. Some central piece, striking and prominent, surrounded by harmonizing articles, or a well-defined symmetrical arrangement of prominent objects will produce the desired effect. The display should consist of articles that harmonize; for instance, gold and silver jewelry in juxtaposition will not have a good effect. Another consideration is brightness. Every article in the window capable of a polish should look brilliant. Cleanness of surroundings, framework, window pane, settings, cases, etc., is indispensable. Not a speck of dust or a blot or blur should be visible to the eye of the spectator. By the use of mirrors the splendor of the effect is greatly enhanced, and if the goods are artfully arranged, will momentarily deceive the spectator into believing that the flooring of the window is twice its actual size.

As before mentioned, the architectural structure is responsible for

many advantages and disadvantages. Unless, as is very often the case, especially among country dealers, the jeweler is the owner of the building in which he has his store, he is governed by the laws of property. But in selecting a new store, a good location, though the principal, should not be the only consideration. The window should be free from obstructions, such as posts, should project well from the face of the house, the flooring should be spacious and high above the level of the pavement, and should have, when possible,

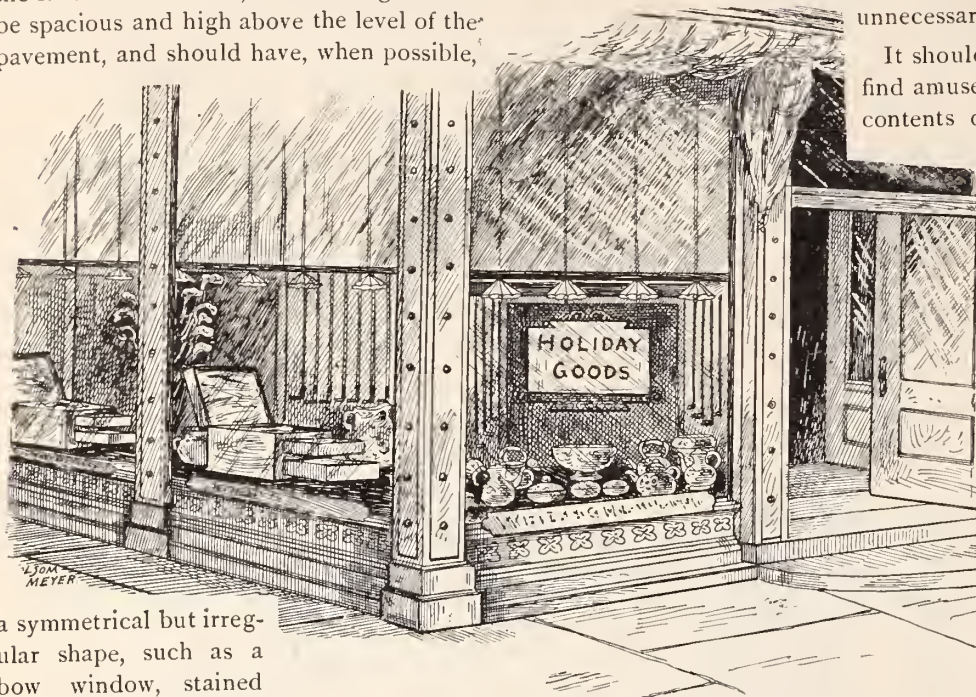

DISPLAY OF THE WHITING MFG. CO.

a symmetrical but irregular shape, such as a bow window, stained glass ornamentation, etc., these latter considerations heightening the effect of the artistically arranged interior. It is customary with many jewelers to put their work benches in the show windows, thus sacrificing an attractive display to gain light. This can be obviated by keeping the base free, separating it from the work bench and tools by a plush curtain. Where the window is to be occupied by the repairer, it may have a higher display base than would be desirable for other lines of goods, as jewelry being of a delicate character, people like to examine it closely, and such a window would be in good taste.

As for the embellishment of the window, exclusive of the goods, much can be said. First, such surroundings as framework, background and settings are an absolute necessity. No matter how well the stock may be arranged, if these are not in keeping the effect will be bad. The bottom should be covered with silk plush, the color being dependent upon the articles displayed. The back should be formed by a curtain or lambrequin of plush, upon a brass rod, or should be composed of sliding doors of rich wood, mirrors, etc. The inside wood work, frames of cases, etc., should be of a most delicate construction, old oak, rosewood or ebony producing fine effects.

In the selection of the plush great discrimination is necessary respecting color. Nothing sets off diamond jewelry so well as black plush, though a slightly funereal effect is produced by its use. For silverware and silver trinkets, peacock blue is undoubtedly the best; old gold is good, while white is excellent. For bronzes, bric-à-brac or any such articles containing a goldish tinge, terra cotta is excellent. For the back curtain, dark blue, old gold or maroon are desirable colors. White being always a suitable color, where plush is too expensive, canton flannel, used in many windows, is a very cheap and good substitute. Then combinations of colors, such as apple green, silk and pink plush go well together. The dealer's wife will generally know the best com-

ination of colors. What is sought is a rich and harmonious effect. Lace curtains add delicacy and should be used whenever opportunity permits, but do not put them close to the window.

Fans, statuettes, plants, bric-à-brac, pottery, etc., will often be found useful auxiliaries in a window, but they must not detract from the effect of the jewelry. As these articles are being gradually added to all jewelers' stocks, this advice to display them may be unnecessary.

It should be remembered that as a large number of persons find amusement and interest in examining and criticizing the contents of brilliant windows, it is necessary to change the window frequently, each time placing something new before the public, and as the thoroughfare is apt to become a promenade in the evening, the windows should be illuminated during that time, incandescent lights being employed if possible.

It may be of interest to the reader to lay before him a brief description of the more salient features of the different window displays illustrated here.

There is a distinct individuality in the window display of Simpson, Hall, Miller & Co.'s New York establishment, illustrated here, which is partly owing to the peculiar architectural structure, but mainly to the time and care that is spent upon this department of their business. The arrangement teaches a lesson which would always prove advantageous to follow. As will be observed by referring to the illustration, the ground plan of the window is semi-hexagonal in shape, and is free from pillars and other obstructions. The window is 13 feet in its entire width and 6 feet in depth, it thus projects well into the street, and its three faces oblique to each other afford a view of whatever is displayed from any point on the sidewalk. There is no display platform other than the flooring of the store itself. This peculiar construction would at first puzzle one as to the capability of an artistic

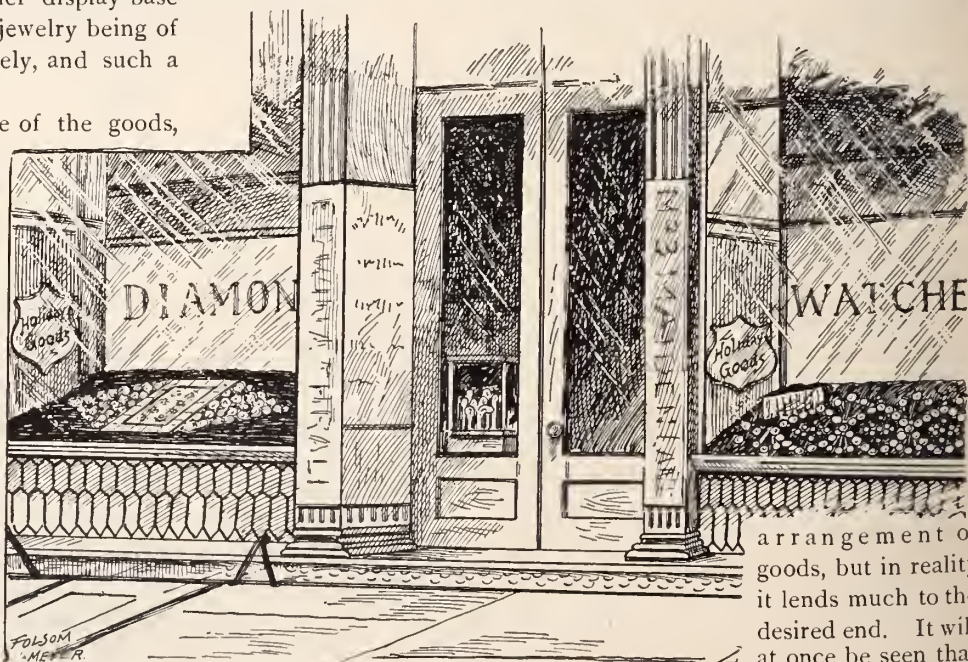

E. A. THRALL'S GEOMETRICAL DESIGNS.

arrangement of goods, but in reality it lends much to the desired end. It will at once be seen that prominent objects must be displayed, and that boldness must be the main characteristic of the arrangement, for if either the former or latter consideration were of a finical nature the window would appear empty.

In the arrangement under discussion, these considerations have been complied with. Prominent in the center of the window space is a beautifully carved old oakwood table. On each side is a painting resting on an easel. Back of the table, one at each side, are two

piano lamps, besides a five o'clock tea and three rosewood pedestals upon which are set large single pieces of silverware. Again, at each side and near the window front is a collection of canes and umbrellas. Complete symmetry thus characterizes the display. The table is covered by a heavy silk plush brocaded cloth of an old gold color

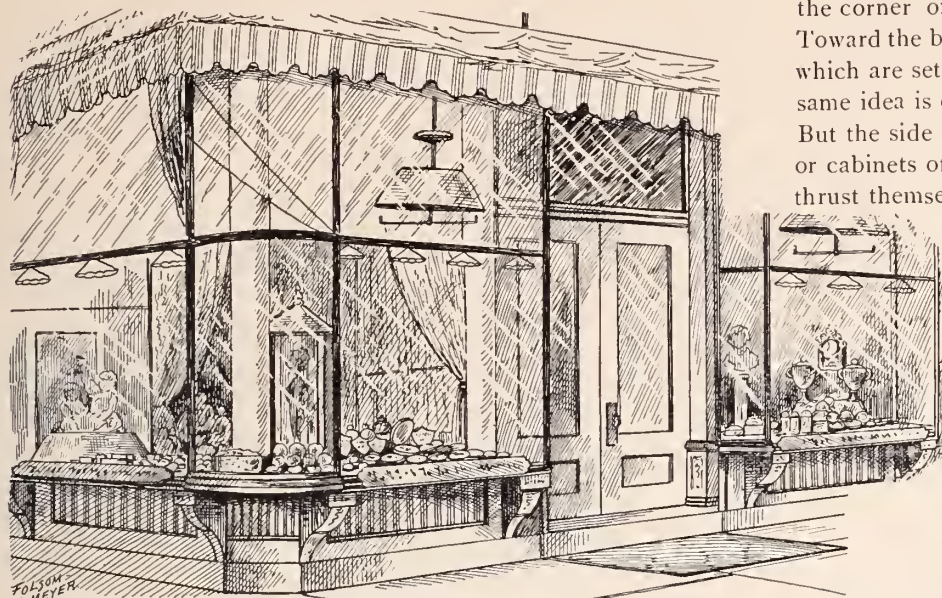

J. H. JOHNSTON & CO.'S WINDOW.

main ground, peacock blue trimming and terra cotta fringe, and has arranged attractively upon it a complete toilet set in silver plate. The floor is covered by a carpet of harmonizing tints, and at the back hangs a sort of portiere of a deep maroon color. Altogether one of the ideas aimed at, to give the window a private room-like appearance and effect, is materialized.

The display of goods upon the table is limited in character only by what is carried in stock; it may consist of a complete toilet set, as in the present case, or a tea service, or, the table being drawn out a complete dinner service which will enhance the private room-like effect, or simply a diversified assortment of small wares. Though old gold is not the best color to set off silver, this and the maroon of the curtain, the lively colors of the paintings and lamp shades, the gold framing, etc., make an attractive ensemble. One might remark that there is too much precision in the arrangement or that symmetry is carried out to a fault, but this very simplicity is the magnet to draw the admiration from passers-by. The precision is an artistic precision, the symmetry an artistic symmetry, and the articles displayed are in perfect harmony with each other. The conception of the use of the table is most excellent. Mr. Machokemchild, of "Hard Times," would have demonstrated conclusively that it is utterly incongruous to place silverware on the floor, and that its proper place is the table. Again, there being sufficient room in the window for one to move about, the goods may easily be taken out for examination. The idea of conveying a private room-like effect is carried out in the interior of the store by the use of rugs, carpets, small tables, chairs, etc. Such an effect is particularly pleasing to ladies.

Regarding the windows of the Whiting Mfg. Co., their attractiveness is the result more of the quantity and richness of the articles displayed, and the architectural spaciousness of the window fronts than of artistic arrangement. The windows, as may readily be perceived by referring to the illustration, are not suitable for elaborate dressing. The floorings are too narrow and the store elevation too

high. But the street frontage being over 50 feet, an opportunity is afforded for making a gorgeous display, and this being taken advantage of, the Whiting Co.'s windows are among the most attractive in New York. The surface of the window bed is simply covered with fine flame-colored silk plush, in which in the first window from the corner on Broadway lie snugly numerous pieces of silverware. Toward the back rise little plateaux covered with the same plush, upon which are set beautiful single pieces. In the second window the same idea is carried out, but with small ware symmetrically arranged. But the side windows are by far the most attractive; six large trunks or cabinets of spoons and forks, arranged in line from end to end, thrust themselves upon the attention of the pedestrian, whether he be walking on the side street or on Broadway. This is the salient feature of the whole window dressing and must prove a good advertisement for the house. Above these are displayed rows of silver-headed canes which hang head downward, producing a peculiar but attractive effect. At the diagonal, where the side and front windows join, is another row of canes similarly hung. When the row of seven incandescent lamps in each window are lighted, its effect upon the brilliant silver, plush, fine woodwork, etc., is simply dazzling. A mirror at the further side of the second window and the fine black framework enhance the general effect.

Perhaps the class of goods most difficult of attractive arrangement is diamond jewelry. Seldom do we find a window displaying such that attracts our attention solely by force of the artistic beauty of its dressing. But when once drawn, no class of goods rivets the attention so completely or excites so much interest, for the ordinary person has a love for gems and delights to gaze upon them. This being true, it would prove advantageous to dealers to vary their window dressings occasionally with a special display of gems. But it is evident that there must be some peculiar

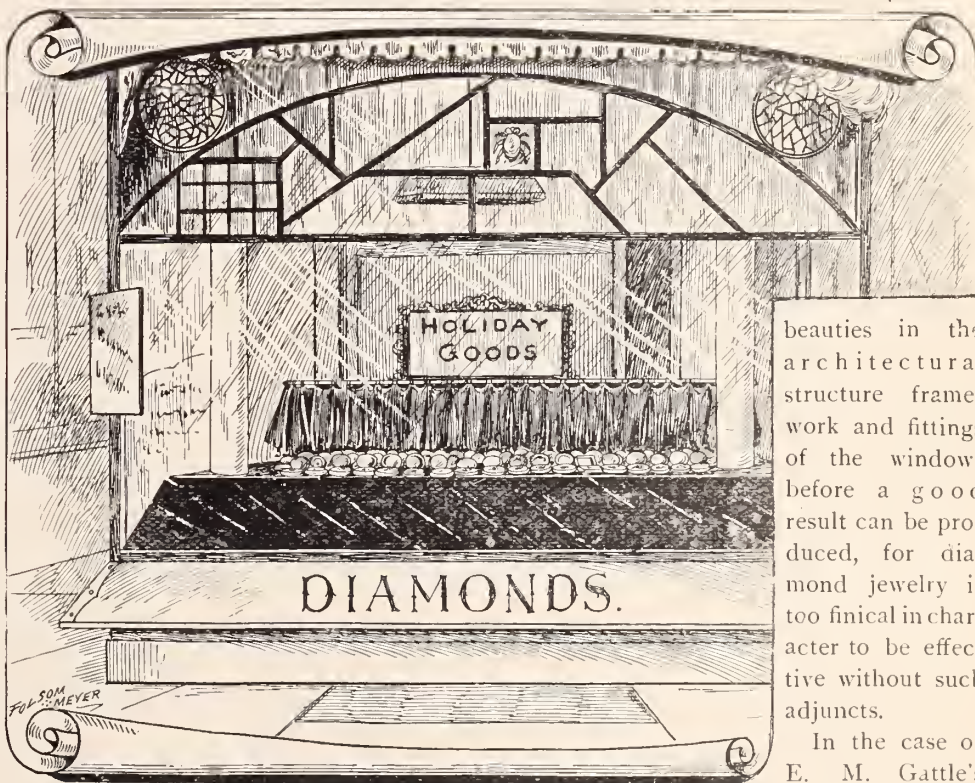

DISPLAY OF DIAMONDS, E. M. GATTLE.

beauties in the architectural structure framework and fittings of the windows before a good result can be produced, for diamond jewelry is too finical in character to be effective without such adjuncts.

In the case of E. M. Gattle's windows, the architectural details are in themselves attractive. The store occupies the corner of the street and has three windows, the corner one only being shown in the illustration. This window is 17 feet in length, while the other one on the main street is 18 feet, and the arc on the side street 8 feet. The upper portion of the windows is composed of variously shaped small beveled panes of glass, with a few oddly-designed stained glass ornamentations. The floorings of the windows are broad

and from them rise plateaux of even height and like character that run continuously around, except where broken by the street door. At the back are glass panels and sliding glass doors, all in fine framing, and a glass cover roofs over the window at an anterior height of about five feet, practically turning the lower portion into a mammoth show case—an effective detail which also protects the goods from dust. At the far end is set a mirror at an angle to reflect every article in that window, adding greatly to the brilliancy. The framework is of a black color.

As to the draperies and carpetings, a narrow red curtain hanging loosely on a pole forms a suitable background. The plateaux are covered at different times with fine black or delicate sky-blue cloth tightly pressed over the wood, as in the engraving, or loosely and carelessly spread. The pillars, otherwise obstructions, are made a point of attraction by being draped with beautiful sky-blue material. The display of jewelry is quite profuse, but is arranged symmetrically, the trinkets lying in pretty cases of a delicate light blue color. The display in the far window consists of several trays of rings. The effect of the continuous spread of brightly covered base, combined with the delicate shadings of the colors, the fine framework and fittings, the beauty of the exterior structure, is enhanced by glimpses of the interior of the store afforded from the outside.

The attractive dressings of E. A. Thrall's windows are well-known in New York. From an architectural standpoint there is nothing peculiar in the windows, though they are admirably adapted to the ideas carried out in the displays. There are two windows whose floorings, about five feet in width, are at a good elevation from the sidewalk, are of slight pitch and about two feet deep. Mirrors at angles to produce effect are set at the sides, bright wood work forms a good framing, and blue cloth is tightly spread over the base. These accessories are of ordinary character and may exist in any store. But the attractiveness of the windows lies essentially in the unusual arrangement of the goods. Starting out from a central point in the base, one idea is ever in the mind of the dresser, to depict some geometrical figure or combination. In the present instance we perceive in the first window, mainly, a conventionally-shaped diamond design; upon closer inspection, another but smaller diamond is seen within. The outer diamond is composed of watches bordered by chain bracelets, queen chains, etc. The inner diamond embraces finer jewelry, such as scarf and lace pins, brooches, etc. The design is set in the center of the space; hence it stands out prominent and hardly ever fails to excite attention. In the other window the display consists of bracelets, necklaces, etc., arranged in a series of interesting diamonds, and is as effective as the other. But this exhibit is by no means the best that Mr. Thrall has made. On one occasion "THRALL"—"1889," distinctly defined with one hundred gold watches and chain bracelets, proved very striking; on another, "E. A. T."—"1889," attracted the attention of numerous pedestrians, and so on. The dressing is varied every day, and no memorandum being kept of the designs employed, it scarcely happens that an idea is used twice. The field of such geometrical shapes being practically unlimited, it depends solely upon the imagination of the dresser whether or not novelty shall characterize the daily exhibit. Greek crosses, Maltese crosses, stars and crescents, or simple flowers, such as the clover or pansy, may be employed with effective results. The habitue of Maiden Lane wonders daily as he proceeds down the street what new conceit is represented in Mr. Thrall's window. The good lessons they thus contain can readily be followed by every jeweler, and would prove of great advantage to those dealers whose stock or windows does not permit of elaborate artistic dressing.

The window display at J. H. Johnston & Co.'s Union Square store merits a stronger qualifying adjective than the word "beautiful." It is undoubtedly the daintiest and most attractive in the city, irrespective of the character of the business. It is a common question, "Have you seen Johnston's window?" The exhibit is of too delicate

a nature to admit of bold illustration in black and white, but the main idea may be seen from the one in this article. But first to architectural details. The store projects prominently at the intersection of two streets and has three windows, the two corner ones being represented here. A narrow curved pane between these two may be claimed as a fourth window. The exterior and interior framework is painted black and is very delicate. These two corner windows, together with the curved one and a fine hand-wrought brass high railing within the store, form an oval of equal diameters of about seven feet. In the present instance the whole space is covered by a flooring about two feet from the sidewalk.

The idea of the display was suggested to the dresser, Mr. Stahl, from a painting which he saw while on a trip on the European continent. It represents a temple with surrounding gardens, etc., dedicated to the goddess Venus. Toward the rear center of the window space rises the miniature temple of about a foot square, composed mainly of delicate white material and modeled after the Greek. At the top is a *bisque* figure pouring water, represented by diamonds, over the roof, which is filled with watches. Near this figure is a swallow composed of diamonds. The water gently runs off the roof and trickles down the pillars of the temple, which are studded with diamonds to produce a realistic effect. Within the temple is Venus herself with her favorite flower. At her feet flowers cluster as though they had formed a drapery which had fallen off. From the temple spreads out a lake represented by glass, at the edge of which rests a rowboat of Parian marble with ivory oars dipping naturally into the water. Over the sides of the boat, represented by gemmed jewelry, are a serpent of green gold, a frog with opal back, lizards and other suggestive creatures. Natural pearl shells with pearls form another appropriate feature. Around the lake are lilies, designated by enameled jewelry. From the lake, the remainder of the window's space forms a terrace with flower beds, shrubbery, etc., all represented by jewelry. To enter into minute details is scarcely necessary, this skeleton of a description being sufficient to convey to the reader's mind an idea of the beauty of the window, and what can be done in the way of artistic dressing with a varied stock of jewelry, covering as it will designs suggested by everything in Nature. The drapery of the window, hanging like a canopy of delicate cloud, enhances greatly the dainty effect of the arrangement of the jewelry. A flimsy curtain at the back of the temple conveys a dreamy or cloudy effect, which is appropriate to the temple of such a nature as that of the divine Venus. A pretty background is formed by a finely embroidered curtain, which hangs from the ceiling to the brass railing. The coverings and curtains are all of a creamish white tint. Much time and money are expended in this department of the Messrs. Johnston's store, the goods, curtains and accessories being made for the purpose. The third window, though rich and beautiful, contains no particular lesson for the jeweler.

Unknown to the writer of the above article at the time of selecting the different attractive window displays, it turns out that B. & W. B. Smith, the artistic wood workers, of 220 West 29th street, New York, are responsible for the artistic framing, carving and other woodwork of four of the five establishments where windows are described, the exception being E. A. Thrall's.

—The E. Howard Watch and Clock Co. have contracted to found a large tower clock for the new mill of Johnson, Cowdin & Co., at Riverside, N. J. The dial, 7 feet in diameter, will be of transparent material and will be illuminated by electric lights. A McShane bell, 1,400 pounds in weight, will be attached to the clock, the striking of which will be heard at least 3 miles.

A Retrospect of the Paris Exposition.

AN INTERVIEW WITH M. FALIZE, THE FRENCH CRITIC OF SILVERWARE, AND ONE OF THE JURORS AT THE EXPOSITION.—GENERAL APPRECIATION ON THE PART OF THE FRENCH PUBLIC.—THE BRONZE MEDAL FOR ALL WINNERS.—RUSSIAN ART IN SILVER.—AUSTRIAN AND ITALIAN RELICS.—JAPANESE MANNERISMS.—DIAMOND MINING ILLUSTRATED BY THE CAPE COMPANY.

PARIS, NOV. 10, 1889.

Anxious to know what M. Falize had to say of the American exhibits, I paid him a visit the other day and found the *rappporteur* of the jury for class 24 what he is known to be, viz.: a man at once courteous and truthful. He spoke to me as follows :

M. FALIZE ON AMERICAN SILVERWARE.

"I find it very difficult to give you my opinion about three great American manufacturers in our lines who have exhibited this year. One of them, the Meriden Britannia Co., is so important from a commercial point of view that there is neither in Paris nor in London a house of the same description which might be compared with it; yet their articles are of a kind which I do not consider fully in my province, and you must excuse me from offering any criticism about them. The Gorham Mfg. Co., which occupies so high a rank in America, has shown us an entirely new and unforeseen style in silverwares on which our eyes rest with an agreeable surprise, although it does not seem to agree exactly with our wants. We hear with pleasure that our Heller, who is a collaborateur of that house, has had an important share in this very curious evolution.

The pieces of a special character which the Americans (Tiffany & Co.) show us this year do not appear to have completely conquered the French public. My friends and competitors do not admit of that style. They think that the effort of invention is too visible, not only in the large pieces but also in the small articles for daily use. Yet, in spite of them all, I persist in finding it beautiful, novel and curious, and several persons of taste are of the same opinion. The peculiar effect of this new style is due to an association of shapes and colors which is not easy to define. It does not seem to answer exactly to the name of Saracenic which has been given to it. The artists no doubt applied unconsciously what they had learned from the Japanese, from the Indians, and from us; but it must be acknowledged that they have found a way of their own to make use of acquired processes. We see here a little of everything: incrustations like those which Christofle showed us long ago, the mokoumé of the Japanese, and Tard's peculiar enameling, besides the use of chasing, etching, repoussé and aqua fortis, and a finishing off exhibiting various patinas. But, of course, a special shape had to be devised to allow of all these processes being applied together, and the artist found it in deliberately overlooking all architectural principles. We notice on these pieces neither sharp lines nor mouldings. They remind us of some fruits or flowers, like Japanese vases of a full and round outline. But whereas the latter are potteries, the American types are made of silver most skilfully hammered into shapes not easily obtainable with metal, and decorated in a wonderfully varied manner. The ornaments reproduce Indian flowers, or the most peculiar among the orchids. On some parts we see chased embroidery work so intricate that no eye could follow its interlacings, the effect being enhanced by the introduction of ivory, and sometimes of tortoise shell incrustated with turquoises. I especially remarked a vase made of Japanese mixed metal, showing, besides the peculiar contrast of colors derived from the various metals composing it, an opaque enamel of a palish blue gradually fading into the whiteness of ivory, while here and there some shades of violet correct the cold appearance of silver. Such æsthetics cannot at once impress our people. It is more appropriate to the wants of American society, always longing for something new, and whose millionaires have to be satisfied whatever may be their caprices. We are more *routiniers*, and if we have any freedom of taste it seldom carries us beyond the limits of our traditional art, attached to it as we are by a constant study. Yet a French silversmith, if he be sincere, must acknowledge that these American works are the product of real artists, and it matters very little whether they learned their art from the Japanese, from the Indians, or from us, since it is evident that they use it in a manner thoroughly original and absolutely perfect."

I was glad to hear M. Falize so sincerely confess his admiration for the "beautiful, novel and curious" American style in silverwares; but I think he is mistaken when he believes that he is alone in France, with a few persons of taste, in appreciating it. During the last six months I have visited the central exhibits in the United States section often enough to be absolutely sure that numerous visitors, French as well as others, concur with M. Falize, and how could it be otherwise? A work of art worthy of that name will always be recognized as such by any person who, even to the smallest degree, has the sense of beauty. I have made that remark over and over again in observing the Gorham Mfg. Co.'s exhibit. People

who could afford to buy silver goods were never able to resist the temptation. They often hesitated between many articles on account of the endless variety, and finally made their choice with a sigh, taking a regretful look at the goods which they did not purchase. I noticed some French families from the provinces timidly stepping into the Gorham Co.'s place. At first they quietly took a general survey of the goods, then gradually warmed up, and at last called each other's attention, pointing out this and that with words expressive of wonder. "If I were rich," said the wife, "I should buy that lovely coffee set with those splendid candelabras." "I," said the girl, "would prefer that charming toilet set and the mirror with its bewitching little cupids, etc." One of the principal causes of the Gorham Co.'s unparalleled success at the Exposition is that their



(FACE.)



(REVERSE.)

THE BRONZE MEDAL.

goods never seem too expensive for what they are. The workmanship always looks fully up to the price, which is not always the case, as I have noticed pieces made in such a way that the art spent on them could only be estimated by people in the same line. The Meriden Britannia Co.'s exhibit was appreciated to the last, as it deserved to be; as also the Leroy W. Fairchild Co.'s.

THE BRONZE MEDAL.

Every one of the exhibitors who obtained a reward (from the highest to the lowest) will receive a bronze medal, the same for all. The above illustrations represent (full size) the obverse and the reverse side of the medal, designed by Louis Bottée, whose model has been chosen as the best. Although the artist felt obliged, like his fourteen competitors, to follow the old classical track, he has endeavored, as far as he could, to modernize his style. It is especially conspicuous in the absence of rigidity which we notice in the

attitudes and the arrangement of the draperies. On the obverse, we see the figure of Labor seated on his anvil and holding in his right hand a hammer, while his left is pointing out the Champ de Mars spreading below. Minerva, covered with a helmet and wearing at her neck a medusa head, stretches out her right hand to crown Labor with a wreath. A tree, emblematic of Peace, against which the Goddess of Wisdom is leaning, spreads its branches above the two figures. Underneath, we see the date 1889 rising over the figure of the earth and illuminated by the rays of a hidden sun. The words "*Exposition Universelle*" are inscribed on the border. On the reverse is a figure of Fame, with spread wings, seated in a dignified yet graceful attitude. Her left arm is resting around the bust of the Republic, and she holds in her right hand a long trumpet whose tones are represented as resounding up to the farthest countries of the globe. She stands on a rock, where a wide space is prepared to receive the name of the fortunate exhibitor.

DISPLAY OF RUSSIAN SILVERWARE.

Two Russian silversmiths deserve to be mentioned: Outchinikoff and Chlebnikoff, whose tastefully arranged cases are placed in a large passage separating the Russian Court from the United States section. Their displays chiefly consist in translucent enamels with a gold or gilt silver frame. All these pieces look very pretty and their style is thoroughly *sui generis*. Some able critics have remarked that the work, if closely examined, did not appear quite perfect. I humbly suggest that it must be meant to have this appearance as it could not preserve its intended naive look if it were finished off with too refined an art. For instance, the images of Saints, which remind us of paintings belonging to the pre-Raphaëlite period, would seem out of place with surroundings of a dainty modern treatment. Such as they are, they convey the right impression which Russian works ought to give, and we should be very sorry to find them otherwise. A curious feature of one of these exhibits is a small, enameled, gilt silver lamp, which, being lighted up, shows to the best advantage the pretty colors of the translucent enamel. With the light coming through, it has the effect of stained glass.

AUSTRIA'S REPRESENTATION.

In the Austrian Court, the exhibit of Böhm, of Vienna, is the most interesting. Yet we hardly find there anything novel and original. It consists chiefly in reproductions of grand mediæval pieces, rich in gems and enamel of many colors. It seems like a museum exclusively devoted to the collection of Austrian artistic relics. I must confess that these timepieces, monstrances, croziers, mirrors and jewels are pleasant to look at, and, although the general effect is rather gorgeous, yet the harmonies of color are so well preserved that there is nothing showy about it.

In the Italian Court, most glass cases contain copies of ancient works. Besides a considerable display of coral, we notice everywhere reproductions of old medals or cameos. We find, here and there, especially at Melillo's place, some beautiful specimens of the goldsmith's art, but no effort has been made to show anything novel. Italians seem to have taken it for granted that there could be no demand but for archæological specimens.

JAPANESE MANNERISMS.

Japan somewhat disappointed us this time. It is, no doubt, because we have been accustomed for many years to expect a great deal from that country. The Japanese seem to have taught us all their secrets, and, although we are thankful for it and admire their wonderful skill in all kinds of art, yet we are getting tired of repeatedly seeing their fancy monsters in grotesque attitudes, etc., etc. The fact is, that our admiration has too long been centered on their works, which even has caused us very often to be unjust to other styles. Exhibitions such as we have just had bring us to a more reasonable appreciation of art in all its forms and appearances.

One of the most curious shops—in the celebrated Rue du Caire—is that of an Oriental engraver-chaser (reproduced here). The picturesque arrangement of all his goods, as well as his grave and intent



SHOP OF A JAPANESE CHASER.

appearance, gives him the look of a real artist, and I believe he has done a good business, yet the patterns he obtains with his rude punchers on copper vessels and trays can only be said to look well at a most respectful distance.

DIAMOND MINING ILLUSTRATED.

In Routina's diamond cutting place, established in the pavilion of the Cape, there is a machine, used to pierce diamonds, which makes 13,000 turns in one minute; and as it requires 30 hours to pierce through a depth of one millimeter, this represents for the whirling tool a total of 23,400,000 turns. The Cape Mining Co.'s exhibits have been to the last a magic center of attraction. The interesting relief plan of the Bultfontain claim never fails to draw the attention of visitors, who intently follow all the stages of mining: the digging, the filling up of wagons, and the bringing up of the diamondiferous earth to the surface, where it is spread on large floors, constantly watered and exposed to the action of the sun, so as to get all the soft substances detached little by little. It is then carried to a large

watering machine. The one established by the Cape Company at the Champ de Mars is of a good size and does speedy work. 100,000 kilogrammes of diamondiferous earth have been brought there from South Africa, so that our visitors should see how it is done. The earth, being dumped into a large circular trough, is heavily watered, and constantly beaten by revolving rakes so that the particles of earth attached to the gravel remain suspended in the water, allowing diamonds and pebbles alone to sink to the bottom of the trough. Then the stones are spread on a table, separated from the

porting two rock crystal pieces. This style, which is not easy to handle, as there is a constant risk of producing something strained or confused, is certainly finding its way little by little into our fashionable jewelers' displays.

An exhibitor, whose specialty is to copy ancient works, has shown us an imitation of a rather pretty clock of the eighteenth century.



JAPANESE SILVERWARE.

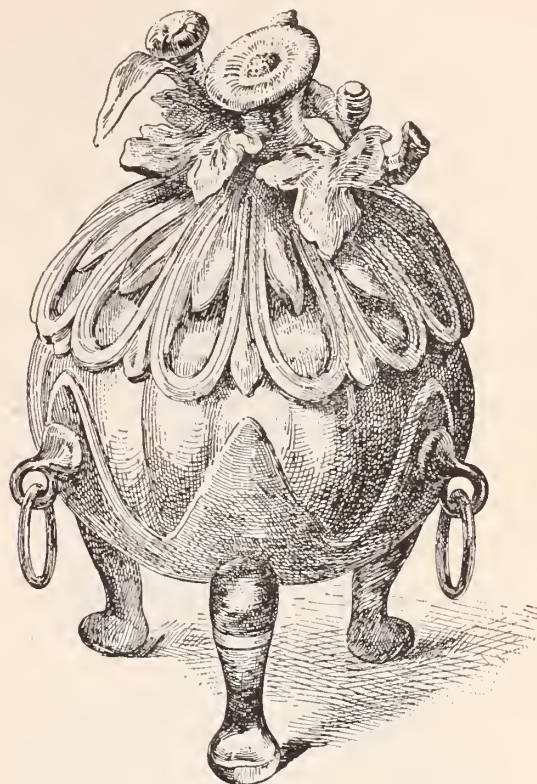

JAPANESE SILVERWARE.

public by a glass, and a man moves them carefully with the hand, looking for diamonds which he puts aside. The precious stones are subsequently cut, polished, and finally exhibited in a capacious glass case, which occupies a prominent place just opposite the entrance of the pavilion. I have been told that the quantity of diamonds found at the Cape represents about eight millionths of the earth extracted.

A DELICATE GOLD AND CRYSTAL CANDLESTICK.

The candlestick, reproduced here, is a most delicate example of the goldsmith's art. It consists of gold interlacings made to represent elegant ornaments of a light and symmetrical appearance, sup-

porting two rock crystal pieces. This style, which is not easy to handle, as there is a constant risk of producing something strained or confused, is certainly finding its way little by little into our fashionable jewelers' displays. Although what he has done is, no doubt, quite remarkable, we prefer to give an illustration of the original, which occupies an important place in the collection of M. Double. This timepiece, in lapis-lazuli inlaid, belonged to Queen Marie Antoinette, as is attested by an inscription engraved on a gold plate. The middle part of the urn moves round by means of a mechanism, and the hour is indicated by the dart of the serpent, the emblem of eternity. On the

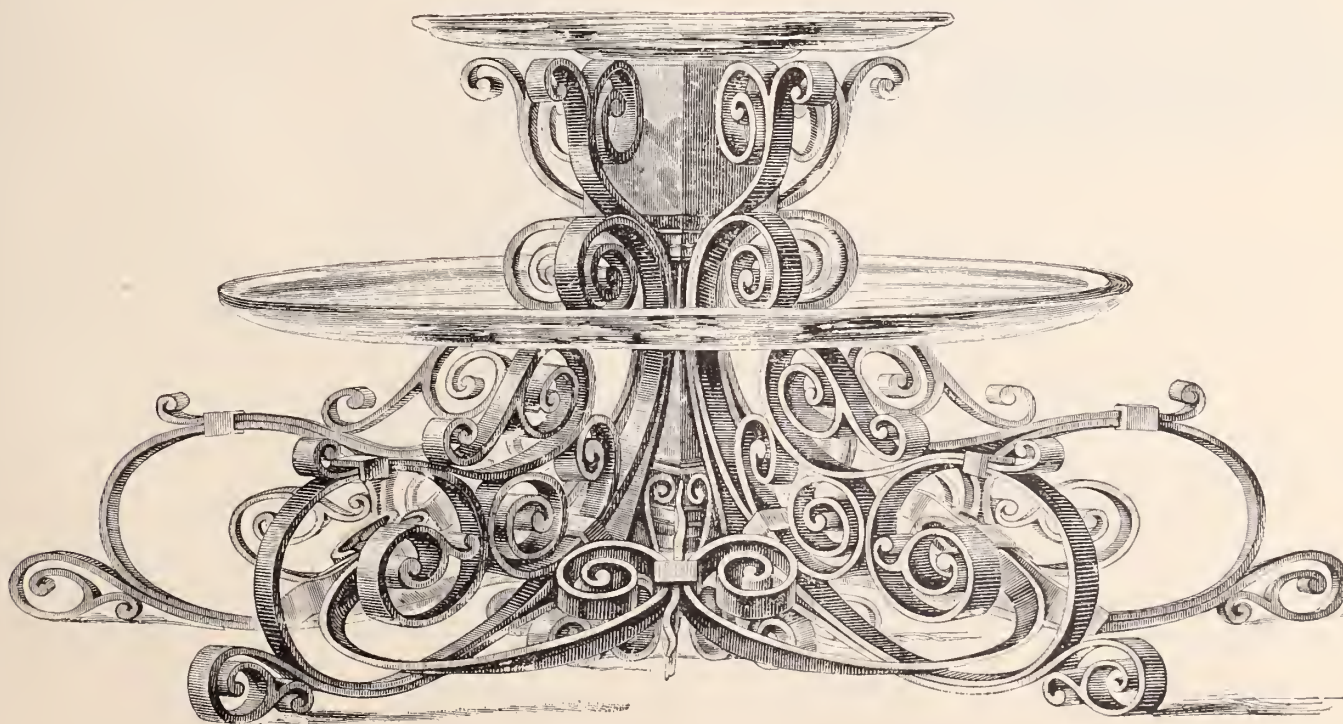

A DELICATE GOLD AND CRYSTAL CANDLESTICK.

pedestal is a medallion in the style of the epoch, inside which are a quiver and a torch slung together by a love knot, all covered with precious stones. The chasing is perfectly done and the gilt parts are

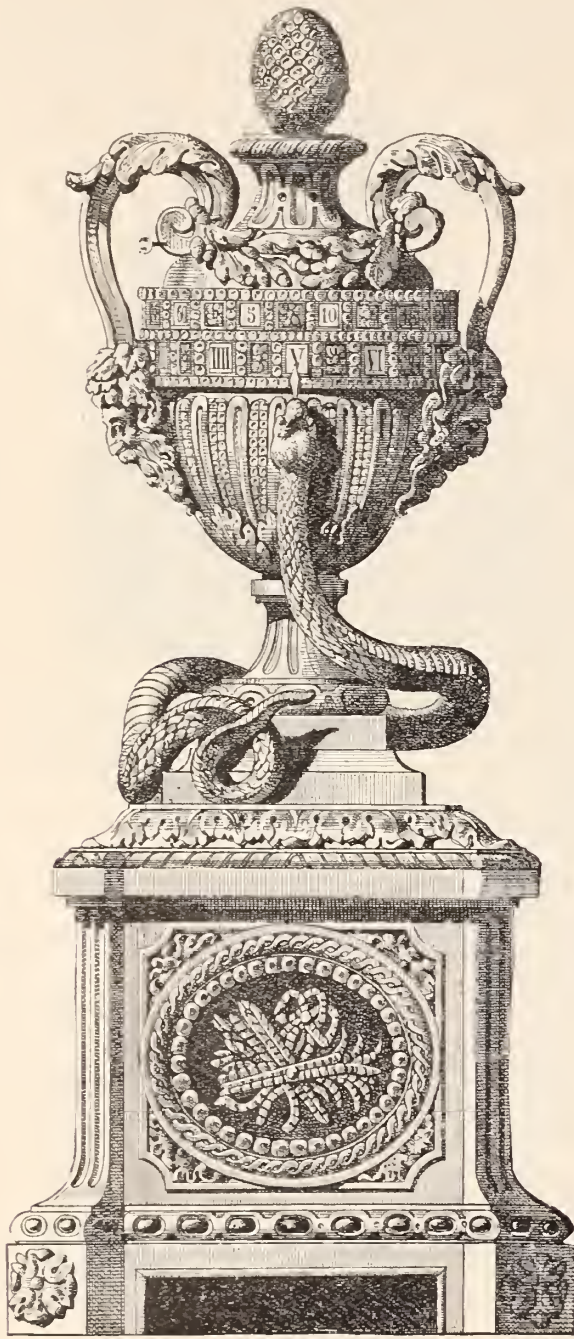

XVIII CENTURY CLOCK.

well contrasted with the others, so that the general effect is most pleasing. It is a beautiful specimen of French industrial art at the end of the last century.

FRANCUS.

influx of labor-seeking immigrants) their production has recently developed to an astonishing degree. The *Geological Survey* and the report of the Director of the Mint for the calendar year 1888, show that our mining and smelting industry stands unrivalled both in volume and value of production. The extraordinarily large increase commenced already in 1887, when the total value of the mineral productions was estimated at \$542,284,225—a sum hitherto not attained by any other nation in the world. "Experts," "adepts," and other equally wise men averred that this marvellous figure was the result of "peculiar circumstances," and prognosticated a heavy decrease for the year 1888. Like Mr. Rory O'Moore's dreams, these prognostications resulted in the contrary, and the total production of the past calendar year shows another marvellous increase of \$50,000,000 as compared with 1887.

A comparison of the total sums for a number of years gives the total value of the metal and mineral production in the United States as follows:

1882.....	\$456,165,489	1886.....	\$465,327,888
1883.....	453,240,758	1887.....	542,284,225
1884.....	413,476,748	1888.....	591,659,931
1885.....	428,713,909		

Presupposing the approximate correctness of these comparative sums, we find a most remarkable increase since 1886. Three successively following years, showing each an increase in value over the previous year of \$37,000,000, \$77,000,000 and \$50,000,000, while the total of 1888 exceeds that of 1884 by \$178,000,000!

By a comparison of the metal productions in the years 1887 and 1888, it will be seen how the artificially raised total value of copper almost equalizes the heavy fall of prices of pig iron; the yield of gold remained stationary, while silver, lead and zinc increased so largely, that in comparison with 1887 the yield of metals generally result in a plus of more than \$6,000,000. The heaviest item of increase in 1888, it is obvious, is furnished by the vast coal industry which, as compared with 1887, has been larger by nearly \$30,000,000. Besides this will be found a respectable array of minerals. Pig iron is indeed the only production which experienced a large decrease of value, while the quantity produced was greater than in 1887. As arranged in principal classes, a comparison of the quantities produced for the two years is as follows:

	1888.	1887.
Pig iron.....	\$107,000,000	\$121,925,800
Silver (Mint value).....	59,195,000	53,441,300
Gold (Mint value).....	33,175,000	33,100,000
Copper (value in New York) ...	33,833,954	21,052,440
Lead (value in New York).....	15,924,951	14,463,000
Zinc (value in New York).....	5,500,855	4,782,300
Quicksilver (value in San Fran.)..	1,413,135	1,429,000
Nickel (value in Phila.).....	115,518	133,200
Aluminum (value in Phila.).....	65,000	74,905
Antimony (value in San Fran.)..	20,000	15,000
Platinum (value in New York)...	2,000	1,838
Total.....	\$256,245,403	\$250,419,283

The Mining and Mineral Industry of the United States.

IT IS NOT, perhaps, within the sphere of THE JEWELERS' CIRCULAR to review the results of the mining industry of the country or establish comparative tables concerning them, yet it cannot forego the pleasure of deviating slightly from its well-trodden path to lay the following before its readers: Our country possesses a wealth of minerals, no doubt, greater than that of any other country in the world, and (perhaps owing to the great

TRANSPARENT GOLD.—If a solution of gold in *aqua regia* be neutralized with carbonate of soda, and the gold precipitated by adding a solution of oxalic acid to the hot gold solution, the gold is precipitated as a yellow powder, showing bright, gold-colored spangles. One examining this precipitate by the microscope, these spangles will be found to be triangular and hexagonal plates which transmit light, the color of the light being dependent on the thickness of the crystal, and when one crystal happens to overlie another, the edges are sharply defined by the difference in color.



[FROM OUR SPECIAL CORRESPONDENT.]

DIAGNOSIS OF THE CONDITION OF TRADE.—A HOPEFUL OUTLOOK.
—USE OF IMPROVED MACHINERY IN JEWELRY MANUFACTURE.
—PRESCOT AND COVENTRY EXCITED.—A QUESTION OF MER-
CHANDISE MARKS.—LONDON'S GROWING APPETITE FOR
NOVELTIES.

LONDON, November 12, 1889.

Whether the hopes entertained by some or the fears expressed by others as to the immediate future of our industries are destined to fulfillment, one thing is very certain, that nearly every manufacturer connected with the jewelry and its allied trades is very busy at the present time. The activity is noticeable even in those branches in which for some time there has been more than usual quietude, and so we find that even our ring makers are busy. Indeed, I have heard of some houses who are not able to obtain a sufficient number of men for particular branches of their work. Good stone setters are just now scarce. Of the numbers who some time since were positively driven from this work because they could not find sufficient employment in it, many have become settled down in other branches, some in other trades altogether, and are not inclined to return to their old lines for what, after all, may be but an ephemeral impetus. It is rather doubtful if some of them would be able to exhibit their old skill even if they resumed their old occupation. Of course, if the demand for this specially skilled labor continues, the supply of it will be forthcoming—it may not be from the old source but it will be found whenever it is ascertained that there is a permanent demand for it.

The most important of our national industries—influences upon the general trade of our country—are our iron, steel and kindred trades. These trades are as brisk as they possibly can be. Engineering trades and every branch of them are as full of work as they have been for very many years. New works are being opened and old ones are increasing their plant and enlarging their premises.

Any one who has taken the trouble to watch trade movements in the past, will find in this one of the most encouraging auguries for the trade prospects of the future. During the past ten days I have been in commercial rooms in Manchester, Birmingham and Sheffield, and during the past week I have been in numerous factories and even more numerous wholesale (jobbing) warehouses. There is improvement everywhere. I don't believe those malcontents who say the business being done is not legitimate—who tell us that the present spurt is only the result of the importunity of travelers, who have induced traders to order more than circumstances warrant. Judging from the greater purchasing power which the increased circulation of money must give, I adhere to my own opinion that we may expect a good trade for both the Christmas and New Year seasons. One feature of the present busy time among our jewelers is that those firms have the best share in it who have the most novelties.

USE OF IMPROVED MACHINERY.

A very noticeable feature of some branches of the jewelry trades is the readiness to introduce the newest kinds of labor saving machinery. This is as it should be. For too long have we been pegging away by hand labor at work that can be done better, quicker and cheaper by mechanical appliances. Our manufacturers have much to learn from yours in this respect and they are beginning to learn it—or, I should perhaps say, to put it in practice, for what is being done now in the way of flattening, stamping and wire drawing

has been known some time, but not applied. Another very strong indication of the present state of trade comes from the assayers and refiners, who report that the quantities of gold and silver passed recently by them to manufacturers is far greater than they have known for some considerable time.

THE MERCHANDISE MARKS ACT.

Our watchmaking industries are again exercised over the Merchandise Marks Act. The trade is under an obligation to the Prescott firms for their efforts in connection with this act in the past, and we can understand their anxiety to get the act carried out in all its provisions. It is, however, unfortunate that in their anxiety our Prescott friends have, unintentionally, no doubt, caused some uneasiness in Coventry circles. It has been suspected at the latter place that some allusions in Prescott to the putting of foreign made movements into English cases were intended to apply to the Coventry people. The matter will, no doubt, be fully explained and the explanation be cordially accepted, but just now the relations between the manufacturers of the two towns are disturbed more than by the usual trade rivalry. This has been keen enough in all conscience, and it is a pity any other feeling should be introduced to intensify it.

The supply of diamonds from the Cape has been but limited during the past month and higher prices have ruled. This has been the subject of considerable complaint, but still it has not interfered with business. Rough diamonds are still in good demand and at fair prices.

ELECTRIC WATCH STAND.

I have just seen in Hatton Garden a unique novelty, the production of Cathcart & Pets. It consists of an electric watch stand. Its application will be readily gathered from the illustration herewith. It will be seen how easily we can ascertain the time during the night

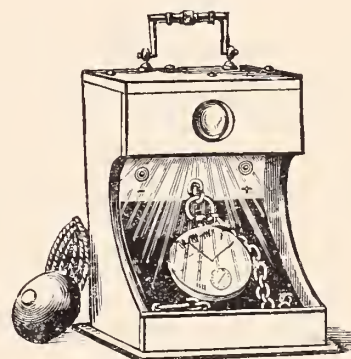

by just touching the connecting button of this useful indicator, or it may be arranged to leave the light on the face of the watch throughout the night. This is likely to become a stock requisite, after it has answered its purpose as a novelty.

THE CRY FOR NOVELTIES.

There is still a good sale for brooches, bracelets, etc. A very novel brooch is a sea shell in natural colors, enameled and surrounded by a circle of diamonds, with a fine pearl in the center. Another new arrangement is in the form of a kitten playing with a ball of cotton, the animal represented in diamonds and the ball by a large pearl. It is intended to be worn as a brooch.

That "men are but children of a larger growth" we have very high authority for believing, but it has been reserved for an enterprising jeweler to ascertain whether the remark may be equally applied to ladies. In his effort to arrive at a solution of this question he has constructed a "monkey climbing up a stick." This has been a time-honored arrangement for the delectation of children. It is only fair to the ladies that I should explain that in the device now specially constructed for their pleasure, the monkey is of gold and his eyes are rubies, while the stick up which he is climbing is also gold. The whole makes a very novel shawl or scarf pin.

VIGILANT.

Fashions in Jewelry

A Lady's Rambles in Search of Holiday Novelties.

GOLD Jewelry is coming in again.

* * * * *

LACE pins are giving place in some instances to small round gold brooches exquisite in design and beautifully wrought.

* * * * *

INTERLACING designs of slender gold filaments, and radiating forms set with seed pearls, repeat the dainty heirlooms left by our great grandmothers.

* * * * *

ENGLISH influence is seen in oblong brooches of chased gold in which are seen colored jewels. One such gave an effect of yellows with topazes imbedded in gold. Another was sprinkled with small diamonds. Others have stones of different colors, rubies, sapphires, and emeralds alternating, and with a diagonal scroll of seed pearls.

* * * * *

FLORENTINE designs in round brooches show the most beautiful goldsmiths' work. The forms which are rich in themselves are elegantly chased. Occasional diamonds set at the points of continuity in design add greatly to its beauty.

* * * * *

THE PORTRAITS in enamel and the paintings on ivory that were in favor last year are even more fashionable this year. Last season Madame Recamier was the favorite beauty. This year it is the Duchess of Devonshire, from the Gainsborough portrait, a poignant face from beneath a colossal hat. It is set as a round brooch with eight festoons of diamonds.

* * * * *

OTHER famous beauties are set as small tambourines with pearls instead of bells.

* * * * *

THE SOFT radiance of the moonstone is a favorite effect in round brooches. The prettiest design is in radiating pear shaped forms around a common center, and showing but slender defining lines of gold.

* * * * *

DIAMONDS only serve as the mounting for large pear shaped pearl pendants.

* * * * *

A MAGNIFICENT pendant is an Egyptian head cut in brownish toned onyx which at night shows brilliant lights. The costume—the feather adorned head dress, the necklaces and waist garniture is copied in rubies.

* * * * *

BLACK onyx with a dead finish is used for mourning. It appears in the double violets, pansies and buttercups that are so perfectly reproduced in enamels. Diamond centers and dewdrops are used in the same manner on the black jewelry as on the colored.

GOLD cuff buttons follow the renaissance designs now in favor. A peculiar pattern is called "the propeller" the model being the propeller itself. They are either highly polished or one arm is polished and the other chased. Another has a fringed edge.

* * * * *

THE latest back combs are mounted in gold of Florentine design, richly chased. The more elegant models are sprinkled with diamonds.

* * * * *

ONLY the amber lining of the tortoise shell is used in side combs. This is much more expensive than the darker lines.

* * * * *

SIDE combs mounted in gold repeat in the most delicate workmanship Italian beadings and mouldings that are found in architecture. The Florentine scroll work alluded to before introduces diamonds.

* * * * *

SIDE combs chaste enough for a Quakeress are mounted with a tiny gold rim in which are set turquoises or small diamonds in straight rows.

* * * * *

THE DARK tinted tortoise shell in back combs is unmounted. Instead it is elaborately cut in perforated Florentine designs.

* * * * *

LORGNONS of tortoise shell are fairer objects of art, so fine is their carving. Those especially rich have spirals set in small diamonds. A Lorgnon of amber shell simulates a stock of bamboo.

* * * * *

MRS. KENDAL, who is of an inventive turn of mind, congratulates herself on a lace fan she has invented which dexterously conceals an opening through which she can see without being seen.

* * * * *

CRYSTAL vinaigrettes are immeshed in gold net work.

* * * * *

NO WORKMANSHIP is too fine, and no jewels too rare to enrich the vinaigrettes prepared for the holidays.

* * * * *

GOLD bonbonnieres are covered with repoussé work. Sometimes a plain center on the lid reveals a locket. This is for women. Others in the same way conceal a mirror. These are for men.

* * * * *

A PURSE of chamois, beautifully wrought in iridescent beads has a gold mount in Florentine chasing.

* * * * *

THE CHANGES in the ornamentation of silver ware are marked and for the better. The solid repoussé work has yielded to plainer surfaces and the contrast throws the design into proper relief.

* * * * *

HIGH polish has almost altogether taken the place of oxydized silver. What is known as butler's polish is given to table ware. It

is a good test of the purity of the metal. Excessive ornamentation lends itself to debased metal.

* * * * *

FLORENTINE designs are found in table and toilet silver. It takes the form of large foliated scrolls to which are given a high polish. These mingled with repoussé work give the chasing on the latter the relief of a plain surface.

* * * * *

HEAVY broken chased edges finish salvers and large silver dishes. They make a beautiful mount for plain highly polished surfaces.

* * * * *

COLONIAL pitchers of silver have plain surfaces broken by graceful garlands in relief and finely chased.

* * * * *

THE OBLONG cake and bread baskets of perforated silver recall the silver of fifty years ago.

* * * * *

PERFORATED bonbon dishes come in different sizes and are dainty table pieces.

* * * * *

COMBINATIONS of perforated designs with chasing is the last work in the ornamentation of silver.

* * * * *

A LARGE and magnificent dish for table use combines repoussé work elaborately chased, set among Florentine scrolls, highly polished and with the heavy broken chased edge alluded to above with claw and ball feet.

* * * * *

THE POPULAR spiral is found in silver coffee services. The spirals form the base and are polished to the last degree of brilliancy. The upper part is slender, straight, and reflects like a mirror.

* * * * *

SILVER is used to an even greater extent in toilet articles. It follows the prevailing ornamentation, which consists of plain surfaces surrounded by rich Florentine designs. It has a merit that will be appreciated, inasmuch they are much more easily kept clean.

* * * * *

PLAIN silver trays with heavy broken edge are used for the brush and comb.

* * * * *

TORTOISE shell dressing combs are mounted in chased foliated designs.

* * * * *

MANY of the latest brushes and combs are in silver gilt. The plain surface is used for the monogram, which is cut through the gold and shows in the silver beneath.

* * * * *

MANICURE trays have to a certain extent taken the place of boxes. These have a richly chased edge. The manicure articles lie in niches in the tray.

MANICURE boxes are also made of silver. One such has richly chased, carved, polished, renaissance scrolls. It is lined with pale blue satin. Underneath the lid, holding the implements is a jewel case.

* * * * *

MEN'S hair brushes, silver bordered, come in pairs and are to be applied one in each hand at the same time. In view of the national baldness the reason for this waste does not appear.

* * * * *

THE LARGE reading glasses that are so commonly used now are surrounded by richly chased silver bands.

* * * * *

OPERA glasses that are ornamented with etching are much more convenient to hold and less hard on the gloves than those in raised work.

* * * * *

STICKS for holding opera glasses are gaining ground. The large places of amusement require the use of glasses so steadily that these are a great convenience. They are of silver, opening out like a pencil case and are chased and etched. The bamboo furnishes a favorite model.

* * * * *

SILVER pen holders have plain surfaces varied by bands of chasing. Very pretty ones are ornamented only by slender etched rings.

* * * * *

SILVER buckles have heavily chased surfaces in relief. The prettiest to my mind are in fancy links, the lines being ribbed.

* * * * *

THE GIRDLES of silver that Sara Bernhardt introduced in "Theodora," are in rich Byzantine designs. They are especially effective when worn with thin materials. They might be very suitably utilized to loop up the lace fronts of tea gowns.

* * * * *

SILVER skewers have sword-like hilts.

* * * * *

A LONG slender stem wound with a silver spiral and surmounted by a tiny coin is a butter pick pretty enough for an ornament.

* * * * *

SILVER candlesticks are introduced in classic shapes with highly polished spirals.

* * * * *

A SILVER column wound with a wreath serves as a candlestick.

* * * * *

A COMPLETE novelty in the shape of a purse is a hollow cup of silver or silver-gilt repoussé work, to which is attached a crochet top with cords so that it can swing on the wrist. It does not swing, however, but is caught up in the palm of the hand. This purse is intended for change required for frequent use, and is really most ingenious and convenient for woman-kind.

* * * * *

LADIES still carry those oblong portmonaies which have been lik-

ened to a shillaly or a policeman's baton. They are so heavily mounted in silver that they might serve for a weapon of offence or defence

* * * * * *

Those who like their hands unburdened prefer the little flexible purses of woven silver or chamois with coin clasps.

* * * * * *

FOR MEN of luxurious and also mechanical tastes are silver rulers edged with Italian perforated scroll work.

* * * * * *

CIGAR cases for men of sporting tastes have enamel faces on which are painted hunting scenes.

* * * * * *

A VERY pretty use of silver is to break the design and reveal an underlay of tortoise shell or ivory. Umbrella handles are treated in this manner, showing the rough stick beneath.

* * * * * *

The broad surfaces of shoe horns offer a field for suitably suggestive designs that has not yet been occupied.

* * * * * *

JEWEL boxes of rich woods with silver mounts are a feature of the season.

* * * * * *

SILVER calendar mounts of raised and chased work already anticipate. A silver crank is used to keep pace with the days and months.

Art Glass, Ceramics and Bric-a-Brac.

NONE of the Christmas preparations are more beautiful than the American cut glass.

* * * * * *

FANCY a colossal cologne bottle with a glass stopple ten inches in circumference. This stopple is faceted and almost as carefully cut as a diamond. At night its prisms are alive with color. A fortunate man has two of these.

* * * * * *

THE NEWEST cut glass dishes are shallow with large squares and a fan edge.

* * * * * *

WINE sets in spiral glass are last and most expensive novelties in this class of manufacture. The polish given to the spirals is indescribably brilliant.

* * * * * *

THE STEMS of some of the wine sets make them truly objects of art. It takes five pieces of glass to perfect these stems and it is not so many years ago that no workman in this country could make them. Now they surpass foreign pieces.

* * * * * *

HOCK glasses come, like jewels, in elaborate cases. These glasses are colored in green and amber. Cut in blocks, the color is pierced

and is thrown into relief like a gem by the prismatic band of white glass around it.

* * * * * *

GLASSES of ruby gold are a triumph of color. The peculiar incandescence is obtained by gold really dissolved in the molten glass.

* * * * * *

FACETED handles of glass are introduced on knives and forks.

* * * * * *

VASES of cut glass are used for flowers. They have the advantage of showing the stem in the water, which is a pretty sight rarely displayed.

* * * * * *

THE LOUIS XVI craze has brought about all sorts of pretty novelties in white faience, adorned with garlands and mounted in gilt.

* * * * * *

CANDELABRA of Dresden china are the prettiest things imaginable. Shepherds are making love at the base to short skirted shepherdesses. Above them spread the flower-like branches of pink and blue shades of buttercups, and violets encompass the colored candles.

* * * * * *

LAMPS are fairly upholstered. Conceive a tall mustard yellow vase on a low ebony pedestal. A vine in wrought iron climbs around the vase. Above this are the handsome brass fixtures. Over all is suspended an umbrella like shade of yellow silk fringed with the most gorgeous Japanese chrysanthemums.

* * * * * *

A TALL white and gold vase lamp, has a fluted white silk shade, trimmed with deep lace, lifted at the ribs, and garlanded with large branches of pale pink and white clover. The most gorgeous effects of color are secured through these combinations of silk, lace and flowers.

* * * * * *

WROUGHT-IRON is preferred to brass by the high art devotees. The most delicate leaves and vines are imitated in iron.

* * * * * *

THE COLORING of the newest Rookwood pottery vies with that of any foreign manufacture. More literal fidelity is observed in the floral decorations and the shapes are exquisite, particularly in the rare shaped vases.

* * * * * *

THE ARTISTIC competition between the great porcelain and faience houses is so keen that they keep a pretty steady pace with each other. The only thing especially individual in color is seen in the metallic tints of the Doulton ware. Gold is in high favor on every hand.

* * * * * *

ROSE cups in leaf saucers are intended for black coffee.

* * * * * *

RUSSIAN enamel has been revived in this country, it being conspicuous in mirror settings, vases, center pieces and even in knives and forks.

* * * * * *

A SARDINIER is formed of pond lily leaves in faience.

PARIS GOSSIP.

[FROM OUR SPECIAL CORRESPONDENT.]

THE CURTAIN FALLS ON THE GREAT WORLD'S FAIR.—HOW IT IS REGARDED BY THE LOCAL TRADE.—LESSONS OF THE FAIR.—COURTING FASHION'S FAVOR.—PREVALENCE OF ROCOCO STYLES IN SILVERWARE.—INTERNATIONAL CONGRESS OF HOROLOGERS.—IMPORTANT ARCHÆOLOGICAL FIND.

PARIS, November 10, 1889.

Parisian as well as provincial retailers are very glad to see the Exposition come to a close. They all say that business has been rather slack for them during the last six months. Obligated to acknowledge that the World's Fair has met with an enormous success, they naturally wish they had to an extent benefitted by it. If really our retailers have had so little to do this year, from May to

was much pleased to see, at the Champ de Mars, that instead of reproducing the same forms and styles as they used to, each people is endeavoring to find on its own soil and in its immediate surroundings special artistic inspirations, which are bound to give, in course of time, an individual character to all their goods. The revival of old national styles in each country seems to be, everywhere, the first stage of a great development leading to something original, yet bearing the characteristic mark of each race.

LOUIS XV. STYLE IN SILVERWARE.

In silverwares the fashion is not likely to alter for some time. Manufacturers have made large stocks in the Louis XV. style, and we must be prepared to see nothing but rococo articles in all our shops for months to come. Yet it seems as though we might expect a revival of the genre Louis Seize, at least for a certain class of goods. I have seen at a shop window in the Rue de la Paix a lovely jewel casket in that style. The lid is adorned with a course of garlands of roses gracefully drooping, caught here and there by a pretty bow knot. An oval medallion circled with a run of pearls is in front of



MODELLING SHOP.—FINISHING LOUIS XV. SILVERWARE.

October, I hope they have availed themselves of that unlooked-for opportunity for visiting the Champ de Mars as often as possible. It is getting more and more necessary for them to develop their taste and to extend their knowledge in all branches of their business, so as never to be puzzled by any remark from a customer. Even in keeping within the limits of their own field, they had a large scope for study at the Exposition. If only a few of them have taken due note of all improvements in horology, and learnt, besides, to recognize the true character of all styles in jewelry and silverwares, they will soon be able to bring their class up to a level from which they can afford to look down on the competition of the grand bazaars.

I sincerely hope, too, that our manufacturers, giving up all infatuation about the superiority of French historical styles, have carefully examined the articles exhibited in foreign sections, and endeavored to find out new processes which can lead, economically, to the making or finishing of different kinds of original and elegant pieces. Evidently the object ought not to be to copy what is done elsewhere, but simply to try and profit by foreign improvement. I

the lid. The two larger sides of the body show dainty enamel paintings, representing scenes from Queen Marie Antoinette's life at Trianon. On the two smaller sides are rustic trophies consisting of a rake, a spade, a hedging bill, a cage and an elegant garden hat with flowing ribbons, the whole being arranged with apparent carelessness and partly entwined with delicate foliage. This style cannot admit of quick and easy treatment, and all chasers acknowledge that it requires a great deal more care and skill than the average Louis Quinze style. However intricate the work may be, the rules of perfect symmetry have to be observed. I have seen some Louis Seize bon-bon boxes and snuff boxes whose workmanship showed more time and talent than the average rococo *surtouts* and *jardinières*. If we enter a modelling workshop, like the one reproduced here, we are sure, for the moment, to see artists engaged in finishing either a model of Louis Quinze coffee pot, or a candelabra supported by a figure, as those of Roettiers, one of Pierre Germain's competitors. I hope they will soon show us something different. I really do think that French people have lately seen quite enough of that style.

THE INTERNATIONAL HOROLOGICAL CONGRESS.

The International Congress of Chronometry met at the Observatoire de Paris on the 23d of September. M. Philipps, a member of the Institute, especially dwelt on the question of metals employed in the making of the spring and the balance. For many years this eminent scholar has insisted on the necessity of trying all metals likely to give good results for compensation. He has found that all experiments prove palladium springs to be superior to all others on account of their perfect anti-magnetic and unoxidizable properties. M. Philipps also informed the congress that he had studied the influence of the various kinds of balances on the compensation. He found out that with a steel spring balances with bi-metallic rectilinear leaves are more favorable for compensation than circular balances, as they consist of more leaves. The congress passed a resolution that the government be asked to meet all the expenses attending a series of experiments, to determine the compensating qualities of the different metals or alloys employed for springs and balances, and also of the various types of balances.

OLD ROMAN JEWELRY UNEARTHED.

M. Geoffroy, the eminent manager of the French School of Art at Rome, discovered some time ago in the new district of Prati di Castello, two sarcophagi. One of them contained a skeleton only. In the other one, found to be that of a young woman, were various articles of adornment, reproduced here, and a wooden doll, thirty centimeters high, with articulated limbs. The doll, which may have been gilt, was found seated on the right shoulder of Crepereia (name engraved on the sarcophagus' lid) according to an old Roman cus-

tom. The jewels are: a beautiful gold necklace with jasper pendants, thirty-five of which are preserved; a pair of gold ear rings, with pearls; an amethyst cameo brooch (showing a hippogriff and a deer fighting), mounted with gold; a massive gold ring, having on the bezel a cornelian, with two hands clasped together engraved on it; a hard stone ring bearing the name of Filetus; a ring made of

two thin gold circles, moving on a hinge; an amber pin very long and carved into a kind of spiral; a little silver mirror and two combs in wood. These articles in old Roman days were often adorned with bands of ivory and incrustated with worked gold.

JASEUR.

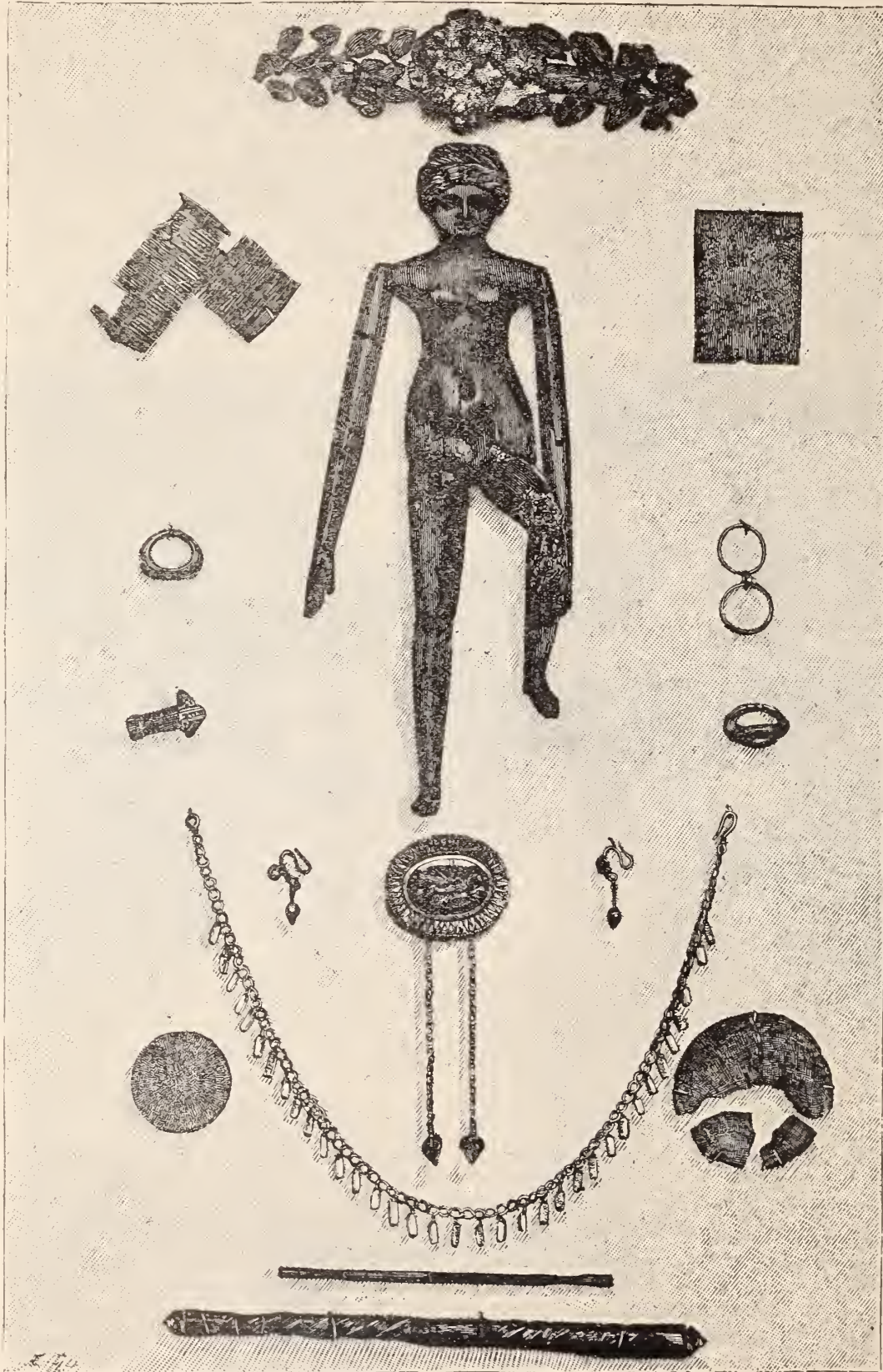

OLD ROMAN JEWELRY.

HOW TO LUBRICATE.

Good oil will neither dry up nor become sticky, except after considerable time; we, therefore, would advise the watchmaker to get the best watch and clock oils to be had, because the good rate of the timekeeper depends on the quality of the oil with which it is lubricated. Next, be careful not to apply too much. Many workmen put on so much oil that it runs all over the jewel plates, and arbors, gets into the teeth of the wheels, and everywhere else where it is not wanted, collects dirt, and makes a greasy mess generally. There should be enough to lubricate the pivot or part oiled, but no more. In good watches, oil every pivot of the movement, and in common watches, lubri-

cate also the lever pallets, the cylinder and escape wheel—but not the ruby pin. In very fine watches this oiling is omitted. In clocks, oil every pivot and bearing throughout—except in some kinds of regulators and the like, which require special treatment. But in all cases, remember the rule: Do not put on too much oil

Copyrighted 1888 by Charles A. Bucklin.

Mechanical Ocular Defects.

Their Nature, Cause, Correction and Relations to Functional Nervous Diseases.

EDITED BY C. A. BUCKLIN, A. M., M. D., NEW YORK.

[The aim of the author is to produce a clear and thoroughly practical course of instruction on the subject of "mechanical ocular defects," which is entirely void of useless technicalities and within the easy comprehension of every thinking student without his having had any previous technical or mathematical education.]

WE WILL continue the consideration of diseases of accommodation. The gradual process by which the lens becomes less elastic while the muscular system is becoming rapidly developed was considered in our last article on diseases of the accommodation. In presbyopia there is no loss in the muscular element which produces accommodation. The lens from its loss of elasticity simply fails to become more convex when the capsules which contain it are relaxed. Errors of refraction, disease of the lens, and the previous use of unnecessarily strong convex lenses may cause the amount of presbyopia found at a given age to vary widely. Thus, a person having a myopia of $\frac{1}{4}$ will not require glasses to read with till after he is sixty-two years of age. On the other hand an individual who is hyperopic $\frac{1}{4}$ will require convex seven to read with. In this case the convex seven represents the amount of his hyperopia and presbyopia combined.

In the individual having myopia of $\frac{1}{4}$ his eyes were exactly focused for objects at fourteen inches without the use of accommodation, consequently he would not require glasses till his presbyopia had become greater than his myopia at which time he would commence to wear the very weakest convex lenses.

There are also many diseases which have a direct influence on the elasticity of the lens. Chronic Glaucoma in its early stages causes the accommodation to sink in a similar manner to presbyopia. The failure of the accommodation is, however, much more rapid in this case than in presbyopia, but it is very frequently mistaken in the commencement for simple presbyopia. Persons who are losing their accommodation as a result of Glaucoma have large pupils; they see rings about all lights at night, and the field of vision is decidedly contracted on the nasal side of the eye or eyes affected.

Cataractous disease of the lens also influences the refractive condition of the eye before the opacity has become sufficiently general to act as an obscurity to vision. During the early stages of the development of cataract, the lens fibers frequently swell, thus greatly increasing the convexity of the lens. This phenomenon is called "second sight." An individual who formerly required convex fourteen lenses for reading and weak convex lenses for distant vision, finds that he can read without any lenses and possibly requires weak concave lenses for distant vision. This condition of second sight is very frequent during the development of cataract. It is the basis upon which all kinds of treatment for cataract to prevent its development has gained a footing. Electricity once used at this stage gained a great reputation for arresting the development of cataract. The fact was the individuals developed the peculiarity of second sight in spite of the use of electricity, and the improvement experienced was credited to the electricity. Persons not treated by electricity, however, develop the same degree of improvement from "Second Sight." This swelling of the lens, however, only produces temporary improvement in the vision owing to the fact that the obscurity becomes so general that it obstructs the entrance of light into the eye.

The ciliary muscle which, by its contraction, relaxes the capsules of the lens and thus allows the lens to become more convex, may, like any other muscle, suffer from *paresis*, *paralysis* and *spasm* or *cramp*.

It will thus be seen that in young persons, where the elasticity of

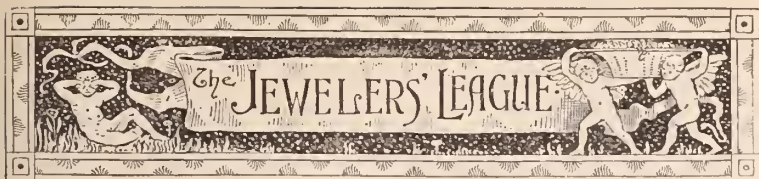

President, HENRY HAYES.....Of The Brooklyn Watch Case Co.
 First Vice-President, JAMES P. SNOW.....Of G. & S. Owen & Co.
 Second Vice-President, ROBERT A. JOHNSON.....Of Celluloid Enamel Co.
 Third Vice-President, JOSEPH B. BOWDEN.....Of J. B. Bowden & Co.
 Fourth Vice-President, CHARLES G. LEWIS.....Of Randel, Baremore & Billings.
 Secretary and Treasurer, WILLIAM L. SEXTON.....Of Sexton Bros. & Washburn.

EXECUTIVE COMMITTEE.

GEO. H. HOUGHTON.....With Gorham Mfg. Co.
 WM. H. JENKS.....With Tiffany & Co.
 A. A. JEANNOT.....Of Jeannot & Shiebler.
 GEORGE R. HOWE.....Of Carter, Sloan & Co.
 WM. BARDEL.....Of Heller & Bardel.
 J. R. GREASON.....Of J. R. Greason & Co.

There were present at the regular monthly meeting of the Executive Committee held on Friday evening, November 1st, Messrs Hayes, Snow, Greason, Jenks, Jeannot and Sexton. Two requests for change of beneficiary were granted. Reports of the Treasurer and Secretary showed the League to be in excellent condition. The following applicants were admitted to membership:

Theo. Borgstrom, Susquehanna, Pa., recommended by W. H. Langford; John F. Coad, Brooklyn, N. Y., recommended by C. C. Adams, and S. G. Lane; Elias J. Kassel, Gainesville, Texas, recommended by J. R. Richards; Louis Kaufer, Brooklyn, N. Y., recommended by S. G. Lane and W. F. Baab; R. H. Roesger, Waltham, Mass., recommended by D. O'Hara. The next meeting of the Executive Committee will be held on Friday; December 6th, 1889.

The Jewelers' Security Alliance

President, DAVID C. DODD, JR.

First Vice-President, AUGUSTUS K. SLOAN.....Of Carter, Sloan & Co.
 Second Vice-President, HENRY HAYES.....Of Brooklyn Watch Case Co.
 Third Vice-President, DAVID UNTERMAYER.....Of Keller & Untermeyer.
 Treasurer, CHAS. G. LEWIS.....Of Randel, Baremore & Billings.
 Secretary, GEO. H. HODENPYL.....Of Hodenpyl & Sons.

EXECUTIVE COMMITTEE.

J. B. BOWDEN, Chairman.....Of J. B. Bowden & Co.
 C. G. ALFORD.....Of C. G. Alford & Co.
 N. H. WHITE.....Of N. H. White.
 F. KROEBER.....Of F. Kroeber Clock Co.
 SILAS STUART.....Of Silas Stuart.
 H. H. BUTTS.....Of H. W. Wheeler & Co.

EXAMINING FINANCE COMMITTEE.

J. P. SNOW.....Of G. & S. Owen & Co.
 HENRY ABBOTT.....Of Henry Abbott.

For further information, Application Blanks for Membership, By-Laws, etc., Address P. O., Box 3277. 170 Broadway, New York

The regular monthly meeting of the Executive Committee was held at the Alliance Office on Friday, the 8th inst. There were present, Vice-Presidents A. K. Sloan, Henry Hayes and David Untermeyer, Charles G. Lewis, Treas., Messrs White, Butts, Kroeber and Geo. H. Hodenpyl, Sec'y.

The following were admitted to membership: Geo. Deuble, 18 S. Market Square, Canton, Ohio; Frederick L. Wilson, 261 Main St., Danbury, Conn.; Bippart & Co., 481 Washington St., Newark, N. J.; Geo. H. Herrick, 1 Park St., Attleboro, Mass.; Carrington, Thomas & Co., 251 King St., Charleston, S. C.; The Jaccard Watch & Jewelry Co., 815 Main St., Kansas City, Mo.; John M. Frear, 71 Court St., Binghamton, N. Y.; Arabella Wilcox, 140 N. Main St., Wichita, Kan.

lens is perfect, we may have defective accommodation as a result of a diseased condition of the ciliary muscle.

Paresis of accommodation is due to a neurosis usually resulting from some of the acute infectious diseases which produce a partial paralysis of the ciliary muscle. Persons having paresis of accommodation *have, have had, or are about to have*, a general disease. The paresis is usually temporary and passes away with the improvement of the general health.

The treatment is hygienic and medical, and never ocular unless the paresis leaves a permanent impairment of the ciliary muscles. Ocular treatment then becomes necessary. The conditions to be satisfied then become the same as simple presbyopia, and is treated by convex lenses in a similar manner.

The following case illustrates well the condition of a child suffering from paresis of accommodation: Miss G—, age twelve years. Distant vision perfect. No error of refraction can be found. During the last few weeks she has not been able to read. Convex lenses No. 36 enable her to read fine print, but she becomes rapidly fatigued when attempting to read with the glasses. Enquiry does not bring out the fact that the child's general health has or is in any way affected. The mother has simply noticed that the child has not appeared as lively as usual. Within ten days she is taken severely sick with high fever and is delirious. The attack may have been malarial or diphtheretic. Its cause was traced to a broken sewer pipe. When the general health of the child was restored, the paresis of accommodation had disappeared. Paresis of the accommodation also appears at all periods of life as the direct results of syphilitic diseases.

Paralysis of accommodation indicates complete loss of accommodation. It has for its cause all conditions which produce paralysis in the young or old. Usually the pupil is also paralyzed and widely dilated. The condition can, however, exist without the pupil being affected.

MUSCLES.

Had an individual but one seeing eye, every point regarding adjustment would have been described under the head of accommodation. Having two eyes which must under all conditions be directed at the same point in addition to being focused for that point, the requirements for adjustment become much more complicated. The slightest failure in an individual's ability to accommodate, or fix as well as an inability to exercise these two faculties in harmonious relations to each other, produces visual disturbances. The following are the muscles which control the direction of the visual axes.

The Internal Recti Muscles.—These muscles move the eyes inward. They are the only muscles which rotate the eyes in this direction, which is an exception to any other set of ocular muscles. Motion of the eyes in all other directions being produced by two or more ocular muscles. These muscles are much stronger than any other set of ocular muscles for the simple reason that the task required of them during the bi-nocular visual act is much greater than that required of any others.

These muscles are constantly under a severe strain when the eyes are used at the working or reading distance as the nearest of the observed objects under these circumstances require strong convergence of the visual axes to be constantly maintained. It will be seen at a glance that any failure in the strength of these muscles will cause near vision to be very fatiguing.

The external recti muscles turn the eyes directly outward. The task of these muscles is complete when they have brought the visual lines parallel for distant vision. The requirements of the muscles are very much less than those of the internal recti muscles, and they are consequently weaker muscles, and do not, when weak, cause the same amount of trouble as a like condition causes when affecting the internal recti muscles. *The superior recti muscles* turn the eyes directly upward.

The inferior recti muscles turn the eyes directly downward. A

weakness in either one of these two sets of muscles makes it difficult to keep both eyes directed at the same height. The slightest weakness of one of these muscles as compared with the strength of the opposing muscle produces the most serious visual trouble. The eyes are more sensitive to a difficulty of this kind than they are to any other form of muscular weakness.

The superior oblique muscle.—This muscle passes from the apex of the orbit slightly upward and inward toward the nose. It here passes through an opening which acts as a pulley. The muscle then passes back over the eye and is fastened to a point which is some distance behind, outside of and above the center of motion of the eye. When this muscle contracts, it turns the visual axis downward and out. When it loses its power it allows the eye to turn upward and outward.

The inferior oblique muscle passes from the inner lower margin of the orbit backward under the eye, and becomes fastened to the eye in such a way that its contraction turns the eye outward and upward.

The above muscles acting together, turn the eye directly outward.

Movements of the Eye.—Its motion inward is controlled by a single muscle, the internal rectus. Its motion outward is controlled by three muscles. The external rectus and the superior and inferior oblique muscles acting together. Its motion upward is controlled by the superior rectus assisted by the inferior oblique muscle.

Its motion downward is controlled by the inferior rectus assisted by the superior oblique. *Defects of the ocular muscles* produce the following results:

First. Grotesque positions of the head are assumed by the individual afflicted, providing the position of the head will place the eye in such a position that the affected muscle is thrown out of use sufficiently to relieve the annoyance experienced as a result of the ocular muscle being unable to perform the usual task required of it during the bi-nocular visual act.

Second. When neither by favoring positions of the eye or use of the muscles both eyes can maintain fixation, we have all forms of diplopia or double vision. The diplopia arises from the fact that non-corresponding points of the retina are exposed to the same visual impression.

Third. When by a fatiguing struggle both eyes are retained in the position of bi-nocular fixation, the muscle which is weak suffers from the strain which is imposed upon it, and we have muscular asthenopia as a result.

The nature of the above described defects, the many annoying consequences resulting from muscular defects, and the various methods necessary for determining and locating muscular weaknesses, will be considered in our next.

Letters asking for information will be cheerfully answered in this department of THE JEWELERS' CIRCULAR.

Friend Dr. Bucklin:

Will you have kindness to explain to me the following case:

A woman, aged 50 years, has been complaining of her eyes a long time, both for reading and the distance, and find her distant $v = 20-70$. She accepts down to $+36$ sph., which gives $v = 20-40$ almost. -40 sph. does about the same. With the $+40$ sph., the three vertical lines are blackest. $+60, 43$ or 40 cyls. axis. $180'$ or $90'$ placed before the $+40$ sphere, makes vision poorer.

On placing a $+40$ cy. ax. $90' \ominus -40$ cy. ax. $180'$ in the frame, she has $v = 20-30$, almost $20-20$. 48 cyls. placed the same way are equally as good, each bringing the lines out equally black.

Is it not contrary to the rule to accept a sphere as this woman does?

What I want to know most of all is how to determine (1) when she has the proper cylinders; (2) how to determine whether she needs a stronger $-$ cyl. than a $+$ cyl., or vice versa; (3) which to put on first, the $+$ or $-$ cyl.; how to tell when I have the correct $+$ cyl. before placing the $-$ cyl. before it.

She cannot read the paper with these glasses, $\frac{+48 \text{ cy.}}{-48 \text{ cy.}}$. How am I to combine the presbyopia with this combination, or must she have different glasses for reading, and what must they be?

If you will oblige me by answering these questions separately, and simplify them

as much as possible so that I can clearly understand them, I will be very thankful to you.

Very Respectfully,

This case, as it stands described, is a peculiar one. The fact, if it be a fact, that she can only read $\frac{2}{4}0$ without any lenses, and that she can read $\frac{3}{4}0$ with either + or — sphericals No. 40, is remarkable and unusual, but not impossible. These cases usually reject all spherical lenses, or at least greatly prefer the same No. cylindrical lens to the spherical lens. If this party had a preference for a cylindrical lens or not, we are not informed.

This party evidently sees better with a spherical lens of either + or — value than without. The + or — lens corrects one meridian, and transfers all the previously existing faults to the remaining meridian. She simply sees a little better with a high degree of simple astigmatism than with mixed astigmatism.

It is contrary to the rule for this class of persons to accept spherical lenses, and I should have been better satisfied if I had seen her accept the spherical lenses, but we have the written facts before us.

The fact that $+ \frac{1}{4}0$ c. ax. 90 \ominus $- \frac{1}{4}0$ c. ax. 180, produces vision = to $- \frac{2}{3}0$, demonstrates that the person has mixed astigmatism. In selecting the cylinders, you take the + or — cylinder which produces the best practical vision for the first cylinder, then cross it at right angles to the previously determined axis with a cylinder of the opposite value, selecting that cylinder which gives the best practical distant vision. Having determined the necessary cylinders in a person who has mixed astigmatism, and is also presbyopia, you will always bring down the + cylinder as a sphere in transposing the combination into a sphero-cylinder, thus:

$+ \frac{1}{4}0$ c. ax. 90 \ominus $- \frac{1}{4}0$ c. ax. 180 would read, transposed, $+ \frac{1}{4}0$ \ominus $- \frac{1}{2}0$ c. ax. 180. Should the individual at the age of 50 require $+ \frac{1}{4}0$ at the reading distance to compensate for his presbyopia, the formula for the reading glasses would read $+ \frac{1}{2}0$ \ominus $- \frac{1}{2}0$ c. ax. 180. With this lens his mixed astigmatism and presbyopia would be corrected. The individual would not, however, see at a distance through such lenses. The first transposed formula would be his reading glasses.

Another year has drawn to a close since the establishment of "The School of Optics." It has been successful, as one hundred and fifty students have received instruction.

The following is a list of the graduates of the class that has just finished the course:—W. T. Lane, Friendship, N. Y.; J. C. Larkin, Johnstown, Pa.; Mary A. Kern, Louisville, Ky.; A. E. Falkenbury, North Adams, Mass.; Wm. H. Gantt, Newport, Pa.; Geo. C. Tolley, not located; Jno. F. Butler, Potsdam, N. Y.; Frank Levison, New Rochelle, N. Y. The next class will form Jan. 10th, at 2 o'clock.

Convention of the Ohio Watchmakers' and Jewelers' Association.

THE regular semi-annual meeting of the Ohio Watchmakers' and Jewelers' Association took place at Dayton, Ohio, on November 13th and 14th, in the rooms of the Board of Trade. President Henry Welf occupied the chair. Forty-three members were present from Ohio and three from Kentucky. After the usual routine business had been disposed of, a greeting accompanied by a resolution was read from the Philadelphia Retail Jewelers' Association, also a resolution from the Minnesota Retail Jewelers' Association, and a committee consisting of John W. Tyler, of Dayton, H. H. Mithoefer, of Cincinnati, and C. J. Olin, of Piqua, was appointed to draft an answer. A number of important communications from members, containing information of value, were then brought before the meeting and discussed.

The association then admitted to membership 18 applicants previously reported to the secretary. It was suggested that the constitution be changed to make the meetings annual instead of semi-annual. The next convention will occur at Toledo, Ohio, on the second Tuesday in June.

C. J. Olin, of Piqua, Ohio; R. S. Mershon, of Zanesville, Ohio, and S. C. Sisson, of Covington, Ohio, "Hard Working War Horses," in the interest of the association, were elected honorary members, Messrs. Sisson and Mershon having retired from the jewelry business, and Mr. Sisson being now Mayor of Covington. Discussions were held on various important topics relating to the National Association of Jobbers in American Watches, the Movement Manufacturers' Organization and the United States Jewelers' Guild, and the Secretary was directed to communicate with the two former.

At the session of the following morning, a committee of two, consisting of the Secretary and Treasurer, was appointed with full power to act to strip plated ware of different kinds and various makes, and report on them by circular or to the next convention. Committees then made reports on the catalogue nuisance and other abuses.

After passing a unanimous vote of thanks to the jewelers of Dayton, Ohio, for their kind attention shown to visiting craftsmen, to the Board of Trade for the use of the hall, to the city press, to Louis F. E. Hummel, of Cincinnati, Ohio, for his indefatigable interest in the association, and the official organ, *The Watch Dial*, the members crowded into two tally-ho coaches drawn by six horses each, and enjoyed a ride about the city and to the Soldiers' Home.

The convention was brought to an agreeable close by a banquet at the Phillips House, given in honor of the Dayton jewelers by the individual visiting jewelers, to which about 40 gentlemen sat down including:

Mayor Crawford, of Dayton; Jno. W. Tyler, of Dayton, Master of Ceremonies; President, Henry Welf, of Cleveland; Secretary, Ed. G. Fohmeyer, of Newport, Ky.; Treasurer, H. H. Mithoefer, of Cincinnati; A. Newsalt, H. Best, J. W. Anderton, F. G. Meyer, A. Moser, F. Sitt, — Eberhardt, H. F. Wiegner, of Dayton; Louis F. E. Hummel, Jos. Daller, S. B. Duncan, J. H. Lentz, H. A. Dodd, Alf. Hellebush, Alex. Clark, Jacob Dorst, H. B. Beckett, Chas. Eick, Wm. Burkhardt, of Cincinnati; Jos. Sauer, of Newport, Ky.; Alvin Thoma, of Piqua, O.; E. H. Lotze, of Girard, O.; Messrs. Loeb and Perry, of Canton, O.; Arthur Totten, of New York; S. C. Sisson, of Covington, O., and W. G. French, with the Derby Silver Co., Birmingham Conn.

After addresses by Mayor Crawford and President Welf, a number of toasts were drank. Speeches then followed from members of the association and visitors.

COURTING FASHION'S FAVOR.

M. Rochas, President of the Paris Commission de la Mode, for popularizing jewelry, is appealing again to the trade for funds. Ladies' journals of all kinds have kept up, at the guild's expense, during the last twenty months an energetic campaign in favor of the wearing of jewels, and in spite of the retailers' grumbling, we are led to believe that a decided revival has taken place. I must confess that these paragraphs are well calculated to attract the attention of fair readers, although they seldom introduce startling novelties. They mention a great variety of articles, from the plain gold bracelets or brooches still fashionable among our *bourgeoises*, to the most sparkling diadem worn by bankers' wives. They often speak of jewels in connection with fine dresses, fichus, bonnets, laces, flowers and other things of interest to an elegant lady. It is evidently a very clever way of introducing jewelry. Besides, I notice that jewels mentioned in periodicals are not only the fashionable ones, but also those which an unaccountable prejudice, no doubt, has neglected for many years past. I read in one of them that the newest fashion is the robe style Empire in white crape, whose low-neck bodice is held on the shoulder (on each side) by a cameo brooch with gold mountings of various colors and a row of diamonds. A similar cameo is said to adorn the front of the corsage, and another, exactly the same, serves as a fastening for a white aigrette on the side of the head, on which red velvet bands are gracefully arranged. I hardly know whether we must consider this jewel as the latest. In any case, I cannot picture well the effect of it, at any distance, on a white dress. Yet, it is evident that these papers do their very best to revive the fashion for jewelry, and I am sure that they will gradually make an impression on the minds of their fair readers, if we are ready to encourage their efforts with something more substantial than praise.—FRANCUS,



Proceedings of the Watchmakers' and Jewelers' Union.

Third Meeting.—Reported by the Secretary.

[NOTICE.—We shall be pleased to receive and discuss descriptions of new tools, attachments and improvements in any branch of our trade, and publish them free of charge; also inquiries from those desiring information on any point of general interest. Communications should be written as concisely as possible consistently with clearness, on only one side of the paper, and be received here by the 10th day of the month, in order to be discussed at our meeting for that month and inserted in the next issue of THE CIRCULAR. Address them to "Secretary of the W. & J. U., care of THE JEWELERS' CIRCULAR, 189 Broadway, New York." For full information for correspondents, see our Proceedings in THE CIRCULAR for October.]

THE LEAD BATH FOR TEMPERING, ETC.

Secretary of the W. & J. U.:

I read in a paper an account of how to temper steel, and it said: "Use the lead bath for tempering." As you offered last month to give information to inquirers, I would ask what a lead bath is and how it is used.

NEW SUBSCRIBER.

Mr. EXPERT replied that a lead bath is a convenient little arrangement rarely seen in watchmakers' shops as yet, but its value is so great that it ought to be used everywhere, and doubtless would be were it better known. It is a vessel of melted lead, in which articles are immersed to be heated, instead of being put into a fire or flame. The advantages are that all parts of the article are equally and evenly heated, whether they are thick or thin, and whatever their shape may be; the objects are protected from the air while being heated, and there is no danger of overheating or burning. In a coal fire or flame the thin parts get heated through before the thick ones, and by the time the latter are heated up the thin parts are overheated or burned.

The lead bath, however, can be kept at any heat desired, and objects in it cannot be heated above that point. Say the lead is kept at a low red heat. It is certain that an article immersed in it cannot be heated above that color. And if left in long enough for the thick parts to become red, the thin parts will be no hotter. If accidentally kept in longer than necessary they do not get above the red, but they would be ruined if left too long in a fire or flame.

A cast iron pot with round bottom gives a good depth of lead in the middle, without requiring an excessive quantity of it. A good sized pot is advisable, as it holds the heat better than a small one, when removed from the fire. The heat is also more even. Some sort of handle for lifting should be attached to the pot; a wire bale will do in the absence of anything better.

As melted lead oxidizes by exposure to the air, its surface should be covered in some way, except when in use. The best cover is a thin cast iron plate, floating on the surface of the lead. Sheet iron would do, but it soon burns out by oxidation. The plate should go loosely in the pot, and the exposed lead around the edges be covered with coal dust or ashes. Through the middle of the plate is a hole, say, 1 inch in diameter, which is large enough for inserting most jobs through it. For anything larger remove the plate.

This hole is ordinarily covered by a smaller plate, laid loosely over it, except at the moment of using the bath. A piece of iron is stuck through it, reaching nearly to the bottom of the lead, to serve as a

heat tester or "pyrometer." On its outer end is fastened a wooden handle, by which it can be lifted out at any time to ascertain the temperature of the melted lead by its color. The color of the larger plate will give a general indication of the heat, and that of the pyrometer is relied on for exactness. Keep the heat at the proper point by watching the color and removing the pot from the fire if the color threatens to get too high. Do not set it on stone or metal, unless you want to cool it rapidly, but on a block of wood or a box of ashes, or merely move it to a cooler part of the fire.

The foregoing describes a lead bath large enough for jobbing. For smaller work, such as case springs, watch pinions, etc., a much smaller arrangement will do, on the same general lines.

On the under side of the cover may be a couple of iron hooks, acting as a sort of cradle, in which to lay a spring or other object while heating, and avoid the necessity of holding it by hand. By lifting off the cover its temperature can be seen, and when hot enough it can be shaken off into a vessel of water or oil for hardening, etc. These hooks, etc., may be merely nails or wires stuck through the cover and secured by a bend above and below it,

In the absence of a cover plate the whole surface of the lead can be protected by ashes, which can be brushed aside to obtain a clear space while working. The small cover with the hooks, etc., can be laid directly on the lead as described. If the hooks do not float deeply enough in the melted lead, put a small weight on the cover, such as a ring of lead or iron around the pyrometer to press it down and keep it steady. If it is made of sheet iron, bind up the edges all around, to make a sort of box, opening upward. That will prevent it from tipping over, as the air in the box is so much lighter than the melted lead that the edge of the cover will not be able to dive into it. Then weight it down as needed.

Many little modifications and attachments will readily suggest themselves to the ingenious workman, who will find this a very desirable addition to the conveniences of his shop.

HOW TO SELL INVENTIONS IN JEWELRY.—SOMETHING ABOUT PATENTS AND PATENT LAWS.

Secretary of the W. & J. U.:

I have invented a new fastening for "flop over" sleeve buttons, that is, movable backs, which I think is valuable. It is easily put in and taken out, and when in it will not unfasten accidentally—only when a particular kind of pressure is given. It is not patented yet. I cannot afford to get a patent until I can find whether it is salable or not. How can I dispose of it without having it appropriated by those I show it to? And what is the best way to go to work and sell it? If anybody can help me out on this it will be a great favor. Yours resp'y, C.

The Chairman called upon Mr. JOBBERSON to reply. That gentleman stated that he was not aware of any way in which Mr. C. could show his buttons to manufacturers without some risk. They are politely supposed to be strictly honest, but he did not warrant them so. Mr. C. should have some witnesses to prove his invention by before he showed it, and he should get his witnesses as soon as possible after the invention is perfected. Then he must show it to jewelry men who manufacture buttons or are willing to take up that line. The button business is not very remunerative just at present, and it is hard to tell who would take hold without trying them on. Any manufacturer who would like to look at Mr. C.'s invention can send his card to us and we will forward them to Mr. C.

Within two years after Mr. C. shows his buttons he should apply for a patent in order to make himself secure. The law provides that a patent is not valid if the article has been in public use or on sale for more than two years before the application for patent. Should any person to whom the buttons were shown proceed to make even one pair and wear them, that would probably be considered a "public use."

It is generally supposed that applying for a patent or giving notice that patent has been applied for, or stamping article "patent applied for," gives some protection to the inventor. But that is a mistaken idea, as is the idea that a *caveat* protects the invention. There is no

protection till the patent is granted and actually *issued* to the patentee. On the day of the date and issue of the patent the owner acquires the right and the power to forbid and prevent other persons from making, using or selling his device without his permission, but he had no such right or power before that date.

Persons who have made the device before that date, with his knowledge and consent, may continue to use those so made, or may sell them to others to be used until they are worn out, regardless of the patent or the patentee—but they have no right to make any more without his permission. If they were made without his knowledge and consent he can stop their use after the date of the patent, and that is all.

This will show Mr. C. just what risk he runs and what his rights are. If he finds manufacturers whom he is willing to trust he may show them his buttons and make the best arrangement he can for their sale. But he must not expect to realize much for any invention in jewelry. If he finds a buyer at all it will be at a very small figure. There is no encouragement for an inventor to devise new articles of jewelry, except in the single case where he can manufacture them himself. Then if they happen to "catch on" with the trade and the public he may make quite a "pile" out of them.

CAN A WATCH BE ADJUSTED TO POSITIONS AS CLOSELY WITH A FLAT SPRING AS WITH A BREGUET?

Secretary of the W. & J. U.:

I should like to have you answer the following question as fully as your space will allow: Can a fine watch with a fine flat balance spring be as accurately adjusted in positions as an equally fine watch with a fine Breguet spring?

An answer to the above will be of interest to a number in this section.

Respectfully yours, C. H. ABBOT.

Leominster, Mass.

MR. ISOCHRONAL replied that this question had been argued and fought over by watchmakers for many years, but it was now conceded that if a flat spring was pretty stiff and had few coils it could be adjusted to positions as closely as a Breguet. But a weak spring, with numerous coils and "sagging belly," of course, could not be. It depends upon the make of the spring itself. If the spring is suitable it can be done, but not otherwise. So far as the variation in the extent of the balance vibrations and the isochronal adjustment enters into this question, it may be said that a flat spring can be adjusted as accurately as a Breguet. But the Breguet is greatly in favor at present, partly because it is easier to adjust, but quite as much so in obedience to the popular belief that it is a superior sort of thing. It is often more profitable to give people what they fancy than to educate them in the value of something else.

WHAT MAKES MAINSPRINGS BREAK.

Secretary of the W. & J. U.:

What causes mainsprings in watches to break—that is, those which are evenly and properly hardened and tempered, and without any undue bending or strain or other apparent cause?

Oftentimes a mainspring breaks when the watch is half run down. Then the strain on the spring is much less than when it was wound up tightly. Any reasoning mind can see that it is not the strain alone that breaks the spring when the watch is half run down. There must be some other agency that causes the atoms in the steel to relax their adherence and causes the spring to part.

That agency is, beyond doubt, electricity. Prof. Wertheim found, after careful experiments, that the elasticity of steel was diminished by a current of electricity passing through it. He also found that the cohesion of the atoms is diminished by a current.

A current of electricity passing through steel or other metal acts the same on the atoms as on the positive electrode in a silver or gold plating bath. The current with the aid of cyanide of potassium causes the atoms of silver to part, and the current carries them from the surface of the metal in the bath. Now, when a mainspring is half wound up or up tightly, every vibration of the balance causes the spring to unwind, which causes the atoms in the spring to get closer to their original position as before the spring was coiled up.

My theory is that when the spring is unwinding the action of the atoms causes

a current of electricity to flow through the spring, which, with the force of the bending of the spring, causes the atoms of the steel spring to part. The current of electricity being almost instantaneous in that short distance sometimes causes the spring to part in a large number of pieces. I have noticed that the more evenly a spring is made and tempered, the more apt it is to break in more than two pieces, which goes to prove that it is not the strain alone that causes the spring to break, but the action of a current of electricity on the atoms or molecules.

It would be quite impossible for the force of bending the spring to cause it to break at the same time in thirty or more pieces, for if the strain broke it in one place there would be no more force on the spring to break it in any other place.

Respectfully yours,

HENRY REMPE.

Danville, Pa.

MR. ELECTRODE responded that electricity might be the cause, but so might heat and cold. Cold increases the adhesion of the molecules, but renders the metal more brittle, while heat weakens it and lessens the cohesion of the molecules. Any variation of temperature would therefore produce a decided effect upon the metal. But the currents which Prof. Wertheim found to affect the elasticity and cohesion of steel were quite strong, and no such currents ever flow through the mainspring of watches when in use.

The current which could be produced in a spring by the vibration of the balance, under the most favorable conditions, would be too minute to be detected. And no current at all could be produced by the balance unless it was magnetized, *i. e.*, was a magnet. If Mr. Rempe means that the periodical relaxation of the spring (unwinding as the balance vibrated) produced the current, it is probable that this current would be still weaker than that produced by a magnetized balance. He was hardly prepared to admit that either one could cause the spring to break. He believed that it would be altogether too weak for that. It is quite likely that electricity has something to do with the fracture of steel, for we are finding that it has something to do with almost everything. And so do heat and cold. But that does not explain *why* springs break, nor prove that they are the *causes* of breakage.

Mr. Rempe was correct when he stated that a spring which was evenly tempered throughout was more apt to break in several places when it broke. But according to his own experience, springs only break through *all* the coils, from center to outside, while entirely or nearly wound up. If the experience of others was the same, that would rather go to show that strain was the cause. A good test of this would be to count the number of the pieces, to see whether it equalled the number of coils the spring would have when wound entirely up, or when partly or nearly run down. If the former, the spring must have broken when it was coiled into that number of turns, *i. e.*, while wound up. This would be a better test than the position of the stop works, because the arbor or the barrel may revolve at the moment of fracture and change their positions.

Now, in such a case, if the fracture of the inner coil came over the top of the hook in the arbor that would seem to show that the bending over the hook caused the breakage. And if the fracture in the next coil and all the others came over the hook too, would not that point to the hook as the cause of all the fractures?

Did any one ever see such a multiple breakage, in all the coils from center to outside, in a line, when the hook did not project or when the inner end of the spring did not serve the same purpose and produce a sharp bend in the coils lying upon it? If not, the strain theory is the most reasonable one.

MR. EXAMINER suggested that there might be a small bit of metal like a hook broken off or something of the kind, between the coils, producing the bend and strain in the spring. Or a hook which stuck out too far might have been filed down properly, so that there would be nothing visible to show any strain. Yet the spring might have been bent over the hook hundreds of times while it projected and weakened just in those places, so that when it did break it broke there. But *why* did it break?

He was inclined to attribute it to some change in the weather, because he had noticed that when one broken spring came in he was pretty sure to have a large number of them brought in within two or

three days, although none had broken for weeks before that. And he had found by inquiring of each customer *when* his spring gave out that they probably all broke about the same time—say, all during the same night, although they were situated in every direction around him—perhaps forty or fifty miles distant from each other in some cases.

Now what could have caused all these breakages all over the country at that particular time? Sometimes this occurred during settled warm weather, when he was unable to point out any marked change of temperature, not even a rain. Was it due to what is known as "electrical storms?" These are believed to be caused by disturbances in the sun, and this explanation seems rather far fetched. But what else could it be but a change in the electrical state of the atmosphere or earth, if there was no perceptible change of temperature, etc., to which it might be attributed?

He acknowledged MR. ELECTRODE's thorough acquaintance with electricity, and the force of his arguments to show that electric currents through the spring could not well be the cause. But if electricity was not the cause in the cases he had just mentioned, he would ask what else it could be?

MR. ELECTRODE thought that closer inquiry or closer observation of the breakages which occur in our own shops or pockets would reveal some sudden change of temperature, or some sudden exposure of the watch to cold, after being taken from a warm pocket. Hanging it in a current of air would cool it greatly and suddenly, and much more so if it rested on a damp cloth while the moisture was evaporating, such as a sweaty vest or the like. But even then he believed that the fracture was really caused by a bend or strain in the spring, helped by the cold.

MR. REGULATOR suggested that it might perhaps be helped by a change in the electrical conditions as well as in temperature. But he agreed with MR. ELECTRODE that what we needed was closer observation of *all* the circumstances which affected the watch when breakage had occurred. He hoped our readers would record all the facts, each time, and by comparing the different instances they might find some cause which had been present in all of them. That would be *the* cause.

IMPROVEMENT IN SPRINGS FOR EYEGLASSES.

Secretary of the W. & J. U.:

As I am unable to get the specifications and drawings before the 10th, I herewith inclose sample of springs for examination by the W. & J. U. The springs are especially intended for eye-glasses made of rubber, zylonite, and the like materials, where two screws or pins are necessary to hold them in position. And the great advantage is that it saves to the workman one-half of the time in putting them in, as he only has one screw to remove. Any man who has had this work to do, can readily see the point. But whether the manufacturers of this class of goods will adopt it for our benefit, as long as it does not benefit them any, remains to be seen. My claim is on the oblong slot, instead of the hole, at the end. This gives the screw just as good a bearing, makes the spring perfectly secure, and simplifies the work one-half.

Yours, respectfully,

A. A. COWING.

Watkins, N. Y.

Mr. EXPERT showed the sample, which was shaped like the ordinary spring, but instead of having two screw holes through each end, it had one—the hole near the end being replaced by an open slot. This, of course, allows considerable margin for variations in the distance between the two screws, and avoids the necessity for inserting a screw in a new place, or making a new hole through the spring. This is certainly a good thing for the repairer to have among his material.

But as to whether the manufacturers will adopt it, that is another thing. Mr. Cowing will, of course, have to make it an object for them to do so, either by offering it to them on liberal terms, or else by making its value known to the trade, so that they will demand it from those who supply them with goods. Anything which the trade calls for they will get, and dealers are only too glad to know what is

wanted, so that they may supply it. Judicious advertising or drumming will doubtless effect the desired result.

WHAT MAKES THESE WATCHES STOP?

Secretary of W. & J. U.:

In response to your "Round Table" inquiry and reply, "What makes my watches stop?" from W. S. M., I would say I have the same difficulty, have also located and overcome the same. I find by using benzine for cleaning watches, that the trouble, as explained by W. S. M., is encountered. I attribute the trouble to the following reasons: The benzine contains a certain amount of oil; apply this to pallet and scape wheel, and as they are brushed, a certain amount of oil is brushed *over the edge of pallet jewels and scape wheel teeth*. This, combined with more or less cleaning powder from watch brush, deposits a sticky substance on impulse faces of pallet jewels and scape wheel teeth, causing watch to bind on the impulse, and to stop at times soon after cleaning, and finally to stop entirely. By cleaning watches with alcohol or any other method, I have no trouble, or, if benzine is used, clean pallet jewel faces and scape wheel thoroughly with pith or peg-wood, and this difficulty is done away with. This same trouble *may* arise from the use of other methods of cleaning, but it is due to the *watch brush not being properly kept clean*.

I should like to have W. S. M. try this and let me know how it works.

Respectfully,

L. F. GUYOTT.

Malone, N. Y.

Mr. EXAMINER said that this would be a very plausible explanation of the trouble if all Mr. M's watches acted in that way. But we understood him to mean that only a certain few watches acted so.

If others have encountered the same difficulty, we would like to have their experiences in overcoming them.

REGULATIONS FOR RAILROAD CONDUCTORS' WATCHES.

Secretary of the W. & J. U.:

I have a customer who bought a fine Howard movement. I told him it should run to about a minute a month. He sets it first by one conductor's watch, and then by another, and then comes in and compares with my clock, and then complains that the watch keeps no time. I told him conductors' watches might be fast or slow a certain amount, and consequently, if he set by them, his watch would necessarily be wrong when compared by a clock like mine that I keep with the R. R. time received here every noon. He claims that conductors' watches must be kept exact, and that, consequently, he gets the exact time when he compares or sets by them. Please give me the custom of conductors with their watches, and how much they are allowed to vary, or, rather, how much they are allowed to get fast or slow in a day, or what are the time-keeping qualities of different grades of watches, as admitted by railroad watch inspectors? Respectfully,

J. D. HOWELL.

Mr. HOROLOGER replied that the watches should be compared with the same regulator, and not with different clocks or with watches. The amount of variation must be not more than *30 seconds a week*. The principal watch companies guarantee their finer grades of movements to run within one minute variation a month, with ordinary usage, so that the conductor can easily find a watch which will run with the prescribed accuracy. There is no general rule obtaining, as regards the running of conductors' watches, but among some of the larger roads the conductor must enter, at a stipulated time each day, as nearly as possible, upon a blank posted at a given station, a record of his time. At the end of the month the inspector strikes an average, and if the watch has varied more than the allowed amount (30 seconds in a week), he is loaned another watch while the former is being repaired or regulated. If it does not then run within the prescribed variation, the conductor must get a better watch.

On such roads chronometers are provided at different stations on the line, all being kept correct and alike by telegraphing the time from a central regulator. There is thus obtained a uniform time over the road, errors from comparing the watches with different timekeepers are avoided, and the watches can be regulated with any desired accuracy. On some roads the weekly variation allowed is different from that stated, but that is rapidly becoming the general rule on all important lines.

Lathes and Lathe Work.

BY THE MODEL WATCHMAKER.

I HAVE demonstrated in a former article that an epicycloid formed by rolling a circle of half the diameter inside any given circle is a straight line. To prevent any misconception, and also to avoid having to refer to back numbers, I will briefly repeat the explanation. At fig. 1 two circles are shown, and to make the explanation as simple as possible we will suppose the larger circle to be a round hole six inches in diameter cut in a plate of brass $\frac{1}{8}$ of an inch thick; this hole is represented by the circle *A*. Inside of this circular hole we place a wheel or disc, *B*, cut from the same kind of brass, three inches in diameter. Now, if we lay the plate having the round hole *A* in it on a smooth flat sheet of metal and place the smaller wheel *B* in it so one side of it touches the larger circle, as shown at *a*, we should have established the necessary conditions for producing a hypocycloid. Next, imagine a very fine tracing point attached to *B* so the center of the point corresponds exactly with circumference of the wheel *B*. If now we roll the wheel *B* on the interior of the circle *A* in either direction, that is, in the direction of arrows *d* or *e*, the tracing point just described and located at *a*, will, as the disc *B* revolves, trace the straight line *a b*. In fig. 2 are shown at *E D* two circles whose diameters are in the proportion of 8 to 1. These circles represent pitch circles, and to form correct teeth so that these circles will properly propel each other is the problem in hand. It will be noticed that inside of each circle (*E D*) are smaller circles, *f g*; these smaller circles generate the hypocycloid for the face of the teeth of each of the wheels. This system of teeth is called by machinists "the radial flank system," but

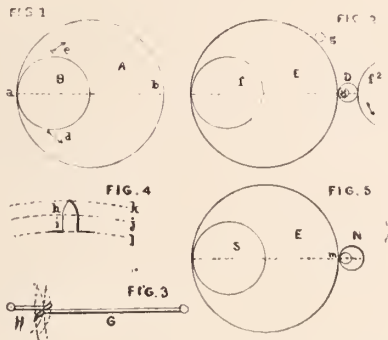

with horological people they are spoken of as teeth with straight sides or faces.

It may be well to give the names of the parts of a wheel tooth as they are known to both horologists and machinists. In fig. 4 is shown at *M* a tooth; in this figure the line *j* represents the pitch line; this pitch line defines the extent of the mathematical wheel, as, for instance, in the two wheels shown at *E D*, fig. 2, which are in the proportion of 8 to 1. Now, it makes no difference whether two wheels are 8 feet or 8 tenths of an inch in diameter, the relation to each other of pitch diameter is the same. To resume about the names. The part of the tooth which extends outside of the pitch line watchmakers call the "point" or *ogive*. This part is shown at *h* in the cut and is located between the lines *j k*. Machinists call this part (*h*) the addendum, and the part shown at *i* (between the lines *j l*) the flank, while the horologist terms this part the "face" of the tooth. In the system of epicycloidal teeth I am describing, the faces or flanks, that is, the portions of the teeth between the lines *j l* in both the teeth of the wheels and leaves of pinions, are simple straight lines, the point or ogive of the tooth being shaped by the rolling circle which generated this hypocycloid rolling on the inside of the mating wheel; that is, the small circle, *g*, is rolled on the inside of the circle *D* and produces the straight line which forms the flanks or faces of the pinion leaves of *D*; it is next rolled on the outside of the wheel *E* and generates the epicycloid which defines the form of the ogive or face of the teeth of the wheel *A*.

In like manner the generating circle *f*, which defines the radial faces of the teeth on *E*, is rolled on the outside of *D* to define the ogive of the leaves of the pinion *D*.

Let me go over the conditions again. A generating circle of one-half the diameter of the wheel or pinion is used to produce the hypocycloid which forms the faces (or flanks) of the teeth or leaves of that wheel or pinion; the same generating circle is used to generate the ogive of the mating wheel or pinion. This system is eminently adapted for watch and clock wheels where the wheels are produced in pairs; but one fact is not generally known about such wheels, and that is that if we construct a wheel and pinion, for instance in the proportions shown in fig. 2, namely, 8 to 1—if we use 64 teeth with a pinion of 8 leaves and shape our ogives as described above, we cannot use a pinion of 10 or 12 leaves and have it work nicely with one wheel. Why? Because a pinion with a greater number of leaves would be of larger diameter and of course the generating circle would be larger and produce a differently shaped ogive. To fully explain this, let us refer to fig. 5, where the wheel *E* (from fig. 2) is reproduced. It again has 60 teeth, but is mated with a pinion (*N*) of 10 leaves and consequently in the proportion of 6 to 1. It is evident that the generating circle *m* of our new pinion is larger and will produce a differently shaped ogive on the teeth of the wheel *E*. Consequently we can see that the "rule of thumb" adopted by most workmen for selecting a pinion to match any wheel by taking a given number of teeth in the pinion calipers cannot give very fine results. Pinions selected in this way will grind along together in some manner, but never produce first-class action. It is only by thoroughly understanding the principles involved that we can hope to attain anything like perfection in such delicate mechanisms as watches.

The reader is not to understand that the only forms of epicycloidal teeth are those with straight faces such as I have been especially considering, because the epicycloidal system admits of many changes by altering the size of the generating circle. We have, in the interchangeable system of epicycloidal wheels, teeth of such form that they will mate with any wheel in which the teeth are formed by an epicycloid produced by a generating circle common to all. This generating circle is usually one-half the pitch diameter of a wheel of that series with 12 teeth; consequently the faces of the teeth in this wheel or pinion have straight radial sides.

The interchangeable system is not convenient for watch and clock making, as in these arts pinions are used with much fewer leaves than 12, and these would have to be very much undercut, which would weaken the pinion. What is required of the watchmaker is to understand the matter thoroughly so as to act intelligently when called upon to correct a fault in "the train." Most workmen who experience trouble in this respect lay the fault immediately to "a bad depth" when in fact both wheel and pinion are of the correct relative sizes, but the teeth of the wheel and leaves of the pinion are incorrect in form. The writer would add that it is only to our horological schools we can look for a thorough dissemination of such knowledge. In this series of articles I shall give a summary of the principles involved which will enable the workman who reads them carefully to judge of the proper form, and when it comes to making cutters for cutting wheel teeth he can realize very near the perfect form.

EXAMINING A WATCH.—When taking a watch down, after having taken off the dial, observe whether anything stands higher than the plate. The screws, barrel arbor and stopwork of low-grade watches are invariably higher than they should be, and the touching on the dial of the movable parts, such as the minute pinion and the stopwork, often causes the watch to stop. The pressure of the screw heads, screw ends and barrel arbors against the dial is apt to cause this to break.



RELIABLE CEMENT.—A reliable cement—one that will resist the action of water and acids, especially acetic acid—is composed of: Finely powdered litharge, fine, dry, white sand, and plaster-of-Paris, each three quarts by measure, finely pulverized resin, one quart. Mix and make into a paste with boiled linseed oil, to which a little drier has been added, and let it stand for four or five hours before using. After fifteen hours' standing, it loses strength. This cement is said to have been successfully used in the Zoological Gardens, London.

RING STICK.—A considerable misapprehension exists in the matter of measuring a ring on a gauge; we would say that the edge of the ring should come as far as the mark, while some contend that the mark on the stick should come inside the ring. This is not right, because any ring properly made is of the same size at the center as it is at the edges, and the ring stick is made tapering, so that when the edge of the ring is pushed up as far as it will go, the center of the ring will necessarily stand off from the stick. In a narrow ring this would make little difference, but in a wide ring it amounts to something.

TO MAKE PLATINUM ADHERE TO GOLD.—Platinum can be made to adhere to gold by soldering in the following manner: A small quantity of fine or 18-karat gold should be sweated into the surface of the platinum at nearly white heat, so that the gold shall soak into the face of the platinum. Ordinary solder will then adhere firmly to the face obtained in this manner. Hard solder acts by partially fusing and combining with the surfaces to be joined, and platinum alone will not fuse or combine with any solder at a temperature anything like the fusing point of the ordinary gold solder.

THE CLICKWORK.—The material of which the clickwork ought to be made is hardened and well-tempered steel, at least for the ratchet and click. The spring might as well be made of another metal of sufficient elasticity, but steel is generally preferred for the more striking appearance which its polished surface gives to the movement. The form of the ratchet tooth is not indifferent. It requires a greater strength if its back is made a trifle convex instead of quite straight. At the same time, the acting extremity of the click is weakened; but this is, in case of wear, much easier to mend or replace. The acting straight side of the ratchet tooth ought to be a little undercut, and a sharp and clear angle at the ground is of importance, in order that the resistance to the strain may be uniformly supported by the whole acting face of the tooth. The durability and good service of the clickwork depend mainly on the good execution of these particulars. It is also very important that the straight line drawn from the center of motion of the click to its acting point be a tangent to the circumference of the ratchet, or what would be the same, that it stands at right angle to the radius of the ratchet at the point of action. In case of a deviation from this right angle, it must be inward—that is, the angle must be obtuse, if the click is so arranged that it is pushed back by the action. If the click acts in a tractional way, the angle can be sharp.

TO MAKE BURNISHERS.—Proceed the same as in making pivot files, with the exception that you are to use fine flour of emery on a slip of brass or copper, instead of the emery paper. Burnishers which have become too smooth may be improved vastly with the flour of emery, as above, without drawing the temper. To prepare one for polishing, melt a little beeswax in the face of your burnisher. Its effect then on brass or other fine metals will be equal to the best redstuff. A small burnisher prepared in this way is the very thing with which to polish up watch wheels. Rest them on a piece of pitch while polishing.

EXAMINING DEPTHING BY TOUCH.—A sharply tapering pegwood is pressed to one end of the pivot so that the pinion only moves with difficulty, while the driving wheel is pushed forward with another wood; by repeatedly pushing the wheel forward, the watchmaker will feel whether the progress occurs gently, without butting or false friction; he must in the same manner feel the shake of every single tooth. The depth may afterward still be placed in a depthing tool, so that he is convinced by ocular inspection. If this style of working has been done for a sufficiently long time, the operator will ultimately acquire a fair degree of fineness of feeling, so that he will eventually be able to judge a depthing by the touch. In the case of pendulum clocks, it is only necessary to gently press with one finger upon the pinion arbor, while another finger drives the wheel. Generally speaking, it is to be highly recommended to open holes for observing a depthing during the going of the watch, as this affords the securest and best guarantee for its quality.

THE MERCURIAL PENDULUM.—“For the uses of the shop,” says Tricotrin, “and for rapid compensation, I prefer the gridiron to the mercurial pendulum, because in the latter the jar of mercury does not as quickly respond to a change of temperature as in the former. It is well known that the temperature increases the higher we ascend in the room; the clockwork is fairly high up in the more heated strata, while the mercury in its jars moves in a significantly cooler temperature from three to four feet lower, and therefore does not respond fully to the heat of the shop. The rods of the gridiron, on the other hand, being longer, pass through the different strata of the heated air, and in their compensation they will more readily respond and express the total of heat in their compensation.”

DE-SILVERING FLUID.—The following is a liquid which will dissolve silver (without attacking copper, brass or German silver) from silvered objects, plated ware, etc. It is a mixture of one part nitric acid with six parts sulphuric acid, heated in a coated bath to 160° F., at which temperature it works best.

GOLD SOLDER.—Proportion for one hundred parts: Silver, 54.74; gold, 11.94; copper, 28.17; zinc, 5.81. Melt the first three metals together in a covered crucible; when the cover is slightly cooled, add the zinc a little in excess of the proportion given, and stir up continually the alloy. This solder runs easily, and is much esteemed by manufacturers.

TO CLEAN IVORY ORNAMENTS.—Ivory ornaments are quickly cleaned by brushing them with a new, not very sharp toothbrush, to which a little soap is given; then rinse the ornament in lukewarm water. Next dry the trinket and brush a little, and continue brushing until the luster reappears, which can be increased by pouring a little alcohol upon the brush and applying it to the trinket. Should this have become yellow, dry it in gentle heat, and it will appear as if new.

RELATION OF TRAIN TO BALANCE, ETC.—The relation of escapement to balance is one which is attracting the attention of many watchmakers just at the present time, especially as it relates to isochronal adjustment. That the relation of train and escapement to balance and balance spring are not important factors in isochronal adjustments, but few who have had any experience will deny. No one, except a novice, would hold that a balance spring perfectly isochronal in a chronometer escapement would be so in a lever using precisely the same balance; it would never give a close rate. I mean by this, to illustrate: Suppose we had a balance, and mounted on the staff were double rollers, one adapted for a chronometer escapement, the other for a detached lever, and we had two movements for which the balance was equally well adapted, and the balance spring was interchangeable; in fact the conditions were as nearly alike as could be, except in the one movement there was a chronometer escapement and in the other a lever. No experienced adjuster, as stated before, would ever give the same results, to say nothing of the isochronal adjustment.

A Universal Handle.

THE *Deutsche Uhrmacher Zeitung* recently published the report of an exposition of tools and auxiliaries, exhibited by the Society of Watchmakers at Berlin; its October number contained the illustration and description of a universal handle which possesses many interesting features.

As will be seen in the accompanying cut, the octagon handle *A* is of the shape of a watchmaker's screwdriver. It is provided at its upper end with a turnable knob for the index finger, and at its lower end with a tube for the reception of different inserted pieces. These pieces, however, are not fastened in the manner ordinarily employed for inserting screwdrivers or drills, but in a peculiar, highly simple and ingenious way, demonstrated separately for sake of greater plainness.

A shoulder at *a* is filed into the face of the octagon handle, and in it is fastened the spring *b* in such a manner that it forms a part of the smooth surface. The spring *b* is with its upper end fastened with two screws to the handle, while the lower end is formed into a kind of click hook, *r*. The inserted piece *e r'* is at its lower end, *r'*, furnished with a similarly beveled hook. When this piece is pressed into the tube of the handle, spring *b* gives way, the click hook *r* snaps into the hook *r'* and holds it securely until the spring *b* is raised again, which motion is effected by a slight pressure upon the small button *k*. By holding the piece downward, it will drop out.

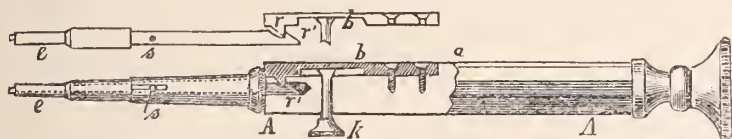

To prevent any movement of the piece *e* in the handle *A*, and to cause the hook *r'* to encounter the hook *r* on the right side, a little pin on the piece *e* catches into the slit *s* in the handle.

The piece shown in the cut is a fraise, with which thin washers, either of gold or some other metal, for increasing the weight of the balance timing screws can be punched out. When to be used for such a purpose, the first part of the fraise consists of a short steel pin of the corresponding thickness of the timing-screw spindle; the outer rim of this first part is sharpened. This pin is fastened to a thicker and sharp turned, tempered and polished part of the fraise, which serves for cutting out the little washers. In use the tool is very simple. Place a piece of plate of corresponding metal upon paste-board or lead, set the instrument upon it and revolve it, pressing somewhat upon the knob, when with a few turns a little washer of corresponding size has been cut out.

This universal handle can, of course, be used for a multiplicity of pieces, such as chamfers, cutting drills, etc. The repairer may make sets of such small tools for the handle. After having used the piece, hold it over the little frame with holes containing the pieces, and drop the tool in its place. On the other hand, when to be used, insert the end of the piece into the tube, see that the pin enters into the slot, lightly press upon the handle, and the tool will snap in.

Apparatus for Mounting the Breguet Spiral Springs.

THE mounting of a Breguet balance spring in the ordinary manner requires a considerably greater time than that of a flat spring, because by trying the former the outer end cannot be fastened in the stud of the balance bridge, as is done by the latter. We were therefore highly interested when we found the description of the following apparatus in a recent number of *L'Union Horlogère*, by the aid of which the mounting of a Breguet balance spring is essentially facilitated. As will be seen in the accompanying illustration, the device consists of a clamp, provided with a stationary pin, *h*, carrying the movable arm *i* with the tongs *p*. The screw *d* is for

the purpose of fastening the arm *i* at an optional place on the pin *h*; the tongs *p* are opened and closed by means of the screw *f*.

The apparatus is used as follows: Having found a suitable balance spring, which is to be tried in the watch before curving the outer coil, the inner end is first fastened in the collet, after which the balance is mounted. After this the movement is placed between

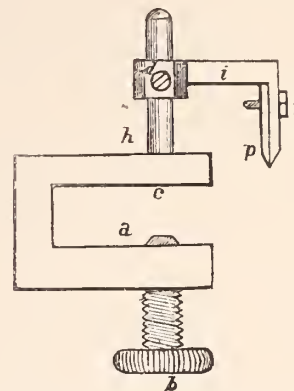

a and *c* of the apparatus and the screw *b* is gently tightened, whereby the apparatus clamps the movement firmly, the screw *b* bracing thereby upon the back of the plate. The arm *i* with the tongs *p* is brought into the correct situation with the balance and secured with the screw *d*; the tongs *p* are then opened, the outer end of the balance to be tested is inserted and clamped in by tightening the screw *f*. The watch can now be tried with ease; the balance spring may be either drawn through or back, or, if required, the spring may be changed until a proper one has been found.

The spring is then curved, by which it must be borne in mind that, when the watch has been timed with the flat balance spring and the curve made in such a manner that the point of fastening is at the same place where it was previously in the tongs, the watch will retard eight or ten minutes in twenty-four hours, because the spring can develop more easily. With a little practical experience, however, it is easy to find the correct point of fastening, and to remedy the small deviations produced by the bending of the ends of the balance spring.

Various Gold Alloys.

THE following mixtures will answer all the ordinary purposes of the manufacturing jeweler for his gold alloys:

- Gold, 22 karats, for wedding rings or medals:*
22 parts fine gold, 1 fine silver, 1 copper.
- Gold, 18 karats, bright:* 18 parts fine gold, 4 fine silver, 2 copper.
- Gold, 18 karats, colored:* 18 parts fine gold, 4 copper, 2 silver.
- Gold, 15 karats, bright:* 15 parts fine gold, 6 fine silver, 3 copper, or 15 parts 18 kt. bright gold, 2 fine silver, 1 copper, or 15 parts 18 kt. colored gold, 2½ fine silver, ½ copper.
- Gold, 15 kt. colored:* 15 parts fine gold, 6 copper, 3 fine silver, or 15 parts 18 kt. colored gold, 2 copper, 1 fine silver, or 15 parts 18 kt. bright gold, 2½ copper, ½ fine silver.
- Gold, 12 kt.:* 12 parts fine gold, 8 fine silver, 4 copper, or 12 parts 18 kt. colored gold, 4 fine silver, 2 copper, or 12 parts 18 kt. bright gold, 3 fine silver, 3 copper, or 12 parts 15 kt. colored gold, 2 fine silver, 1 copper, or 12 parts 15 kt. bright gold, 1½ fine silver, 1½ copper 3 parts fine gold, 12 parts of 9 kt. gold, or 3 parts 18 kt. colored gold, 6 parts 9 kt. gold, or 3 parts 15 kt. colored gold, 3 parts 9 kt. gold.
- Gold, 9 kt.:* 9 parts fine gold, 8 fine silver, 7 copper, or 9 parts fine gold, 7 fine silver, 5 copper, 3 brass, or 9 parts 18 kt. colored gold, 6 fine silver, 3 copper. 9 parts 18 kt. col. gold, 5 fine silver, 2 copper, 2 brass, or 9 parts 18 kt. bright gold, 5 fine silver, 4 copper, or 9 parts 15 kt. col. gold, 4 fine silver, 2 copper, or 9 parts 15 kt. col. gold, 3 fine silver, 1 copper, 2 brass, or 9 parts 15 kt. bright gold, 3 fine silver, 3 copper, or 9 parts 12 kt. gold, 1 fine silver, 1 copper, 1 brass.

A Model Watch Key Factory.

Below is an excellent illustration of the factory of Messrs. Kendrick & Davis, at Lebanon, N. H., manufacturers of the dust-proof watch key, so widely known among the trade and general public.

A recent inspection of their model establishment revealed much of interest, in the way of mechanical invention, illustrative of what business sagacity and honest goods make possible where a necessary article of trade is manufactured.

The manufacture of these keys by Messrs. Kendrick & Davis was commenced in 1876, with but six employees. Jewelers and the public at once recognized the great utility of the key, and constant additions of machinery and help were necessitated to meet the orders sent in, until a force of 115 operatives was required to manufacture the company's out-put.

The inventive skill of the American mechanic, however, gave the firm increased facilities through the production of automatic machinery, which, together with the general adroitness of the operatives, now enable the establishment to make and ship its countless number of keys with a force of some forty hands.

Of itself this key is no complicated affair, but is simplicity itself, performing its work with all ease and perfection claimed for it. Yet simple as it is, every complete key passes through forty-seven distinct operations before the raw material becomes the finished pro-



duct ready for shipment in all its varying styles, of which there are ten, with twelve sizes to each style.

One of the most popular styles with the trade is that of the so-called "Name Key," its popularity being evinced by the fact that the company has on hand steel dies bearing the names of nearly 5,000 jewelers who are using these goods.

On the 10th of May, 1887, the old factory was burned, but with the characteristic energy and pluck, the company immediately rebuilt, and were again making keys on the 6th of the following July, still enjoying the distinction of being, with one exception, the only factory in the United States manufacturing nothing but watch keys.

The interior appointments of Kendrick & Davis' new factory exhibit a marvelous adaptation to the economical handling of the keys in the various stages of the work, and are the result of years of labor in the endeavor to furnish the public, through the trade, with a genuine and honest article. The works are lighted by electricity furnished from their own plant, which is operated by water power.

The factory is pleasantly located on one of New Hampshire's finest streams, and in a busy community chiefly interested in wood, woolen and iron manufactures, among which it holds a commanding place by virtue of its own substantial worth, the same as its manufactured product is held both by the dealer and the consumer.

Notwithstanding the large number of stem-winding watches now in use, the company report their present business as more than good. They are manufacturing the same number of keys as usual, which is accounted for by the fact that the extra quality of their goods has driven the foreign key out of the American market.



* A Complete History of Watch and Clock Making in America.

[By CHAS. S. CROSSMAN.]

Number Forty.

Continued from page 104, November, 1889.

MARINE CHRONOMETERS.

JOHN BLISS.—BLISS & CREIGHTON.—CREIGHTON & BLACK.—
JOHN BLISS & COMPANY.

The firm of John Bliss & Co., chronometer makers, of New York city, has been long and favorably known to many patrons under its present firm name, but when we come to write a history of the firm that shall date back to its original founders, we find it to be one of the oldest established houses in the trade. The business was originally established by John Bliss, Sr., father of the present member of the firm bearing that name. John Bliss, Sr., was born in Norwich, Connecticut, July 15, 1775, and at the age of sixteen was sent to Rutland, Vermont, to serve an apprenticeship with Benjamin Lord, one of the best known watch and clockmakers in New England at that time.

John Bliss, of the present firm, has a silver verge watch which his father finished, gilded and cased in 1815. It is certainly good work and bears the marks of a good mechanic. In 1816 he came to New York City and remained there a few months. Not finding anything to do in his line, he with a few others bought two wagons and moved West, settling in the early spring of 1817 in what is now Janesville, Ohio. He commenced there by making a crude lathe, casting the brass parts himself, and afterwards made surveyors' instruments, and finally did quite a business but did not succeed financially. He floated down the Ohio to Mississippi and finally arrived in New Orleans. Here he formed a partnership with a Mr. Whiteman, under the firm name of Bliss & Whiteman, who did a general jewelry business and repaired chronometers, also securing the agency for Parkinson & Frodsham, the celebrated chronometer makers of London. The firm dissolved partnership, and Mr. Bliss returned to New York City in 1835 and formed a partnership with Frederick Creighton, an English watch repairer, under the firm name of Bliss & Creighton. They started a general jewelry business at 42 Fulton street, and in the following year commenced the manufacture of chronometers on their own account. The business grew rapidly. From 1845 to 1850 the business was at its height and the firm was very prosperous.

They made chronometers in the usual way at first, using the English plates and wheels, making their own escapements, dials and springs, and doing their own jeweling. They also made a good many entire. In 1848 they had an exhibit in the American Institute Fair of chronometers made entire in America, even to the chains, the dials for them being made by Mr. Calvin Cline, who was in the employ of the firm at this time. The firm had a good corps of workmen whom they had educated, as at the time they started there were no chronometer makers in America, and they found it necessary to take watchmakers and teach them the special trade of chronometer making. Up to 1852 they had made upwards of two hundred chronometers, but the shipping business began to decline soon after this, steamships having begun to take the place of sailing vessels. The firm then dissolved owing to some dissatisfaction on the part of Mr. Creighton, who kept the old stand and took into partnership one of his employees named Black, and the business was continued

under the name of Creighton & Black. There was, however, some difficulty in the division of the business and a receiver was appointed, the final outcome being a long and tedious lawsuit, which was not settled until after the death of both participants. Immediately after the dissolution of the firm John Bliss took into partnership his son, John, Jr. (of the present firm of John Bliss & Co.) and started business under the firm name of John Bliss & Son. They were located at 40 Fulton street, next door to Creighton & Black, for a few months, then they moved to Burling Slip and Water street, and from there to John and South streets. In 1867 they went to Wall street, remaining there ten years, and from there to 128 Front street, their present location.

John Bliss died on October 15, 1857, in his eighty-second year. Mr. Creighton died one week later, and his death ended the business of Creighton & Black. John Bliss, Jr., after the death of his father, took his brother George into partnership, and the firm became then, as it remains to-day, John Bliss & Co.

CLINE, SAMMOS & CO.—CLINE & CO.—CLINE & DILLON.

This firm needs a passing mention, as they tried to do something in the chronometer line but never succeeded in accomplishing very great results. The first firm was formed in 1853, and was composed of Calvin Cline, a general mechanic, who had been with Bliss & Creighton, a Mr. Sammos, whose only interest was a monetary one, and Thomas Dillon, a brass turner, who had been making boxes for the same firm. They started in business in Fulton street near the old firm, but remained there only a short time, when they removed to No. 74 Wall street. Mr. Sammos soon found his investment was not a paying one, and with no little difficulty and an auction sale got his capital out of the business. The firm became Cline & Co., for a short time, and then Cline & Dillon, but the business came to an abrupt end, as Mr. Dillon dropped dead in the store one day.

The firm made a few chronometers, but their principal business was in repairing and rating chronometers. Mr. Cline afterwards worked as journeyman for a number of years, but was subsequently heard from as the balance maker at the United States watch factory, Marion, New Jersey.

JOHN FORSTER.

John Forster began the manufacture of wooden chronometer boxes in 1846 at the corner of Fulton and Pearl streets, where he was located until he removed to No. 164 Maiden Lane. He has manufactured most of the boxes used in this country by all the chronometer makers since he commenced business. The boxes are quite elaborately gotten up with brass trimmings. The greater part are of the rosewood veneered on mahogany, though some are of solid mahogany. The usual cost for a good box is about \$10.

JOHN GLOVER.

John Glover was an Englishman who was connected with Dent, of London, and came over to this country to enter the employ of E. & G. W. Blunt, of Burling Slip, agents for the Dent chronometer in New York. He made about forty chronometers before his return to England in 1848. All of his make were engraved: "E. & G. W. Blunt, made by John Glover." After Glover returned to his native land the firm did not make any more chronometers. John Glover is said to be still living in London.

B. & S. DEMILT.

Although the Demilt Brothers were not manufacturers, they were so prominently identified with the early history of the industry in New York City that they deserve more than passing notice. They were the earliest chronometer dealers in New York City, and started

in the importing business about 1795. They finally located at 233 Pearl street, near John, where they also resided. In those days there was a brisk demand for chronometers on account of the importance of the whaling industry, and from the fact that the American vessels engaged in this service had not been able to obtain chronometers to any extent previous to this time. B. & S. Demilt were the first of the chronometer importers to erect an observatory to get their own time, there being no government meteorological service of any consequence then. At that early pioneer stage of the business many difficulties were encountered, but the Demilts surmounted them and amassed quite a large fortune previous to their retirement in 1845. Benjamin Demilt died in 1835 and Samuel in 1845, when the business passed into the hands of D. Eggert & Son, who had been in the employ of the Demilts for some years. One of the Demilt brothers established the free dispensary in Second avenue, which now bears his name.

EDWARD DILLON

Has carried on a chronometer adjusting and repairing business in San Francisco, under the name of Dillon & Co., for more than twenty years. He learned his trade of J. G. Fosler, in New York, and subsequently worked at finishing for T. S. & J. D. Negus and Bliss & Creighton. The demand for chronometers is rather limited in San Francisco, and Mr. Dillon is probably the only one in that city who makes a specialty of this branch of business.

HERMAN REINECKE.

In 1874 Herman Reinecke constructed a chronometer for the Central Railroad of New Jersey, to be placed in their depot in Jersey City. He started in business at No. 30 Maiden Lane in 1878, removing after a time to No. 1 Main street, Brooklyn. Here he carried on a lock business for the Herring Safe Co. and others, in conjunction with his watch and clock business.

GEORGE PORTER,

Who was formerly in business in Boston in the Merchants' Exchange Building, learned his trade of Bliss & Creighton, New York, and later went to Boston to look after their interests there. He commenced finishing on his own account about 1844, making the hair springs but not the balances, and completed several every year until his death in 1861. Charles Bliss, of Norwich, Conn., did a good deal of finishing for him, also making balances. Porter is said to have been a fine mechanic.

DOMINICK EGGERT.—EGGERT & SON.

Dominick Eggert was born in Strasburg, Germany, but went to Bristol England, at an early age to learn the watch and chronometer maker's trade. In 1818 he came to New York, and, locating in Vesey street, started a watch repairing business in his residence. He subsequently entered the employ of B. & S. Demilt, the largest importers in the line at that period, and succeeded them in 1845. He remained at the old stand until about 1870, when the sons who had succeeded to the business, moved to 127 Pearl street. In 1874 they removed to No. 74 Wall street, the present location. In 1866 Mr. Eggert lost his eyesight, which led him to sell his business to his sons, the present firm name of D. Eggert's Sons being then adopted. The Eggerts have made about 250 chronometers. They also deal in fine watches. Dominick Eggert, the founder of the business, died in 1872, at the age of eighty-seven. He was the first man to make a complete chronometer in New York City, and probably the first in that city to make a pocket chronometer.

(To be Continued.)



The following list of patents is compiled from the records of the United States Patent Office, and specially reported to THE JEWELERS' CIRCULAR.

Issue of October 29, 1889.

- Design Patent No. 19,376 to 19,378, inclusive—BRACELET.** EDWARD P. BEACH, Newark, N. J. Application filed September 25, 1889. Serial Nos. 325,078 to 325,080, inclusive. Term of patents 3½ years.
- 413,644—WATCH PROTECTOR.** THOMAS BENFIELD, Newark, N. J., SAMUEL AUFHAUSER, New York, N. Y., and ALEXANDER MILNE, Newark, N. J., said Benfield and Aufhauser assignors to said Milne. Filed May 21, 1889. Serial No. 311,531. (Model.) This watch protector is adapted to contain or hold a watch and is constructed of sheet iron in two sections joined together by means of a coiled-spring hinge, consisting of the pintle and spring, protected by leather or other material, thus allowing the protector to be opened and the watch consulted without removing the watch from the protector.
- 413,654—STEM-WINDING AND SETTING WATCH.** EDWIN H. FLINT, Cincinnati, O. Filed Feb. 12, 1889. Serial No. 299,651. (No model.)
- 413,763—BUTTON OR STUD.** ALBERT RAMMOSER, Berlin, Germany. Filed Aug. 8, 1887. Serial No. 246,475. (No model.) A two-part button consisting of a screw-threaded tubular shank with a headed stud at its inner extremity, adapted to fit into the other part, also screw-threaded and having spring around to catch behind the head.
- 414,054—PENDANT-SET WATCH.** AMOS E. KEEFPORT, Reading, Pa., assignor of two-thirds to Gustavus A. Schlechter and James M. Burkhart, both of same place. Filed Feb. 28, 1889. Serial No. 301,465. (No model.) The salient features in this invention are an axially-moving pendant knob, and a pendant bow having a cross-bar arranged to engage said knob substantially as and for the purpose set forth.
- 414,106—EYE-GLASSES.** ALBERT A. COWING, Watkins, N. Y. Filed June 21, 1889. Serial No. 315,109. (No model.)
- 413,764—MANUFACTURE OF WELDED CHAINS.** HIPPOLYTE RONGIER, Birmingham, County of Warwick, England. Filed Aug. 22, 1889. Serial No. 321,656. (No model.) A process of manufacturing welded stayed chains from a bar of cruciform section by a consecutive series of punching, twisting and stamping operations, the method of narrowing the width of the link being by punching out the middle of the cross-stay and subsequently contracting the width by lateral pressure, so as to bring the stumps together to form the cross-stay.

Issue of November 5, 1889.

- 414,190—WATCH.** JOHN W. CLOUD, Buffalo, N. Y. Filed May 4, 1888. Serial No. 272,863. (No model.) This improvement in watches consists of two independent watch movements in a single casing, each having driving wheels of unequal power and life, said movements being secured one beneath the other in the case and having their hands arranged to revolve around a single center and indicate the time on a common dial.
- 414,449—WATCH REGULATOR.** FREDERICK W. SCHIMMEL, Wallace, Idaho. Filed June 7, 1889. Serial No. 313,488. (No model.)
- 414,526—ENGRAVING MACHINE.** GEORGE M. GUERRANT, New York. Filed May 15, 1889. Serial No. 310,887. (No model.) The combination in a lathe for engraving, of a mandrel for holding and rotating the article to be engraved, mechanism for moving the article and mandrel laterally to produce a zigzag or waving engraved line, an engraving tool and holder for the same, a pattern revolved in unison with the article to be engraved, circuit closing devices acted upon by the pattern, and an electro magnet and connection between the same and the engraving tool for moving the engraving tool in harmony with the pattern.
- Design Patent No. 19,398—SPECULUM.** AUGUSTIN H. GOELET, New York, N. Y. Application filed August 5, 1889. Serial No. 319,835. Term of patent, 14 years.

Issue of November 12, 1889.

- Trade Mark Patent No. 17,188—GLASSES FOR EYE-GLASS AND SPECTACLE FRAMES.** JOHNSTON OPTICAL CO., Detroit, Mich. Application Filed Sept. 3, 1889. Used since Aug. 12, 1889. "The conventional representation of a rainbow."
- Design Patent No. 19,411—BACK FOR HAND MIRRORS, ETC.** GILBERT L. CROWELL, JR., Arlington, N. J., assignors to Dominick & Haff, New York, N. Y. Application filed Sept. 21, 1889. Serial No. 324,682. Term of patent 7 years.
- 414,677—CLOCK OR WATCH KEY.** GEORGE D. CLARK, Plainville, Conn. Filed Feb. 18, 1889. Serial No. 300,297. (No model.) This key consists of a barrel and separately-formed sheet-metal handle, the barrel being provided with retaining shoulders and longitudinal slots on opposite sides thereof, and the sheet-metal handle having hooked arms extending over the retaining shoulders, with the inner edges of the arms within the longitudinal slots.
- 414,697—STEM-WINDING AND SETTING WATCH.** ISAAC GODDARD, Richmond, Va., assignor to Goddard & Moses, same place. Filed July 10, 1889. Serial No. 317,017. (No model.) The salient feature in this improvement consists of a yielding brake lever for stopping the movement of the train when the hand-setting mechanism is operative.
- 414,751—BOX FOR JEWELRY, SILVERWARE, Etc.** LOU BURT, Detroit, Mich. Filed May 27, 1889. Serial No. 312,267. (No model.) This box for jewelry, silverware, etc., is composed of wood covered with a plastic composed of glue and a dark-body material and etched or ornamented on the exterior.
- 414,793—BOW FOR WATCH CASES.** EDWARD C. CHAPPATTE, Philadelphia, Pa., assignor to the Keystone Watch Case Company, same place.

Filed June 22, 1889. Serial No. 315,242. (No model.) A watch case bow consisting of two parts united at one place outside of the pendant.

- 414,802—WATCH CASE SPRING.** JAMES D. EWING, Philadelphia, Pa., assignor to the Keystone Watch Case Company, same place. Filed May 16, 1889. Serial No. 311,014. (No model.) A watch case spring consisting of the combination of two parts, one made heavy and shaped to fit the watch case center and the other made of thin spring metal formed with a projection which acts on the lid, and a transverse leg or prong which fits into a hole in the heavy part.
- 414,804—WATCH KEY.** RHODOLPH H. FRANKLIN, Brooklyn, N. Y., assignor to Chas. C. Cummins, same place. Filed Jan. 24, 1889. Serial No. 297,393. (No model.) In a watch key, the combination of the tube having the round mouth, the jaws having acute and also obtuse angles in contact with the surface of the mouth, and the spring pressing these angles on the surface of the mouth.
- 415,006—JEWELING TOOL.** JOSHUA THOMAS, Elgin, Ill. Filed Mar. 15, 1889. Serial No. 303,447. (No model.)
- 415,034—MUSIC BOX.** HENRY A. GAUTSCHI, Philadelphia, Pa., assignor to Henry Gautschi & Sons, same place. Filed April 19, 1889. Serial No. 307,772. (No model.) In a music box, a safety tune-changing or repeating device or check connected with the tune-changing lever and caused to engage in or with the projections of a grooved gear wheel on the cylinder shaft.
- 415,040—TELESCOPE OBJECTIVE.** CHARLES S. HASTINGS, New Haven, Conn. Filed April 27, 1889. Serial No. 308,771. (No model.) This telescope objective is composed of a positive lens of potash silicate crown glass and a negative lens of boro-silicate flint glass.
- 415,100—PROCESS OF DECORATING WATCHES.** LEON FAVRE, New York, N. Y. Filed Dec. 5, 1887. Serial No. 257,053. (No specimens.) This process of applying carbon prints to metallic surfaces consists in dimming the surface of the metal, applying to the metal surface an adhesive, such as collodion, applying the carbon print to the adhesive, and washing off or removing the carbon paper and foreign matter, so as to leave the print adhering to the metal.
- 415,130—BUTTON.** GEORGE S. TIFFANY, Tecumseh, Mich. Filed May 29, 1889. Serial No. 312,636. (No model.) A collar and cuff button consisting of two substantially semi-circular pieces of metal having angular extensions to form the stem of the button, a fastening pin journaled between the plates of the stem and adapted to be reciprocated, a shoe on the stem, and an arm pivoted on the hinged shoe.
- 414,828—WATCH-BOW FASTENER.** FRED. L. TURNER, Philadelphia, Pa., assignor to the Keystone Watch Company, same place. Filed July 13, 1889. Serial No. 317,377. (No model.) In this device the bow is journaled in the pendant an end formed with a head, and a rotatable and adjustable annular sleeve contained within the pendant, which has a continuous lower edge fitting back of the head and permitting rotation of both the bow and the sleeve.

Issue of Nov. 19, 1889.

- Design Patent No. 19,430—BADGE.** FEODORE A. BERNHARD, New York, N. Y. Application filed October 28, 1889. Serial No. 328,476. Term of patent, 3½ years.
- 415,632—STEM WINDING AND SETTING WATCH.** HENRI GERBER, St. Imier, and HENRI AUDEMARS, Brassus, assignors to Ernest Francillon & Co., St. Imier, Switzerland. Filed May 20, 1889. Serial No. 311,389. (No model.) In a watch, the combination, with a pivoted yoke carrying a central wheel engaged with a tubular pinion, of a wheel mounted on one end of the yoke and engaged with the central wheel and adapted to engage the spring-barrel wheel, a cog-wheel mounted loosely on a pivot on the opposite end of the yoke and engaging the central wheel of the yoke, and provided with a pin projecting from one of its faces, an additional wheel mounted loosely on the same pivot of the yoke with the wheel having the pin, said additional wheel having an aperture larger than the pin and into which aperture the pin projects, this additional wheel being adapted to engage the hands-setting wheels, whereby the jumping of the hands is avoided when the yoke is adjusted to set the hands.
- Second, the combination, with a push-pin having an angular groove and a hands-setting and winding train operated by a pinion through which the push-pin passes, of a lever having one end in said groove of the push-pin, and a screw-pivot which is screwed in the main plate, and provided with a shoulder or disk on which the lever mounted on the pivot rests, and a pin passed through the pivot at the opposite side of the lever, for the purpose of confining the lever between the shoulder and pin and preventing it from moving longitudinally on the pivot.
- 415,659—BUTTON.** JONATHAN T. THORNTON, Providence, R. I. Filed March 22, 1889. Serial No. 304,376. (No model.) This button has two recessed arms connected to the plate in combination with front plate and a disk, this disk being constructed with a concentric and segment depression for the operation of the under or first mentioned plate, all arranged for swiveling and locking the arms in their relative positions.
- 415,669—WATCH CASE SPRING.** HARRY R. GAUL, Philadelphia, Pa., assignor to the Keystone Watch Company, same place. Filed May 29, 1889. Serial No. 312,529. (No model.) A case-spring consisting of a curved piece of thin metal having a projection at about its middle for operating on the cover and provided on its ends with laterally projecting flanges of greater width of metal than the body portion of the spring, so as to extend above the upper edge of the body portion, combined with the watch-case center formed with radial notches upon its upper ledge to receive the upward projecting portions of the lateral flanges of the spring, for the purpose of securing the spring within the center.
- 415,678—WATCH-CASE.** FRITZ MINK, Philadelphia, Pa., assignor to the Keystone Watch Case Company, same place. Filed Aug. 19, 1889. Serial No. 321,259. (No model.) A combined watch-case center and bezel having an open rear portion and provided on its interior with a screw-thread, in combination with a movement-holding ring located within the center and a clamping ring having an external screw-threaded portion for meshing with the internal threads of the center and adapted to hold movement-holding ring within the center.



[THE CIRCULAR is not responsible for the opinions or statements of contributors, but is willing to accord space to all who desire to write on subjects of interest to the jewelry trade. All communications must be accompanied by a responsible name as a guarantee of good faith. No attention will be paid to anonymous letters. Correspondence solicited.]

APROPOS THAT ANTI-SWEAR PATENT.

Louisville, Ky., Nov. 15, 1889.

To the Editor of the Jewelers' Circular:

In your last issue under caption of "Anti-Swear on Top," you take occasion, after deploring that patented articles, especially among the jewelers, are so frequently infringed, to say that G. Felsenthal secured a patent that plainly infringed upon the Anti-Swear. Had you taken the trouble to look at the records you, on the contrary, would have found that a patent was issued to the writer four months or more previous to Scott's. The outcome of the suit, you say, was that Scott & Co. became owners of the patent, but you should have added, by purchase and not by law. The writer does not at all object to your readers knowing that the gentlemen have become sole owners of as much as we had to sell, but does not want to be advertised as an infringer when the circumstances do not warrant it.

Very respectfully, G. FELSENTHAL.

[On investigating the facts in the above matter we learn that Mr. Felsenthal is mistaken when he states that his patent antedates the Scott patents, as we find that Scott & Co. own several patents on their anti-swear button which antedates his. And, furthermore, it was not until suit had been commenced against him by Scott & Co. that Mr. Felsenthal offered to sell his patent, and the overtures came from him. Scott & Co. state that they do not wish to reflect in any way on Mr. Felsenthal or his firm, and that it was not their intention to do so in any of the articles recently printed in regard to this matter, but only to call attention to the fact that they sued Mr. Felsenthal and are now the owners of his patent.—ED.]

KIND WORDS

Chatham, N. Y. July 17, 1889.

S. P. HOWARD,

8 John Street, New York;

Yours of 13th was duly received with check enclosed. I was a little surprised, as I did not think the gold would bring so much, as the prices given me by others were so much lower; I thank you for your honesty and promptness. Hereafter I'll know where to send my old gold. Your address was taken from THE JEWELERS' CIRCULAR & REVIEW; or I would not have trusted a stranger from every paper, for the CIRCULAR advertises none but trusty and business like firms.

E. D. ROOT.

Cincinnati, October 7, 1889.

The October number certainly is complete, and if there could be any complaint it would be the fact that there are so many good things in it, that one is forced to take the time to read them.

E. & J. SCHWEIKERT.

Chicago, Ill., October 10, 1889.

The New York CIRCULAR has done us good.

EXCELSIOR SIGN CO.

Oconto, Wis., October 12, 1889.

I would not be without it.

W. H. GRUNERT.

Hyndman, October 12, 1889.

Much valued CIRCULAR.

A. G. CRABLE.

Gunnison, Colo., Nov. 14, 1889.

I sent you Sept. 11, a money order for \$2, to pay for renewal to CIRCULAR. Think it must have gone astray if you have not received it. Please continue sending the paper; would rather send you another \$2 than be without it.

E. E. MUELLER.

Keota, Ia., Nov. 18, 1889.

I must say that I should feel lost if I had to get along without the CIRCULAR, so herewith find \$2 for another year's helping hand.

THEO. A. MAUCH.

Cumberland, Md., Nov. 19, 1889.

THE CIRCULAR is too valuable to do without.

F. C. ROESSLER.

Morrisville, Vt., Oct. 21, 1889.

Have taken THE CIRCULAR for four (4) years, and cannot get along without it.

FRANK E. HEALEY, JR.

London, England, Oct. 22, 1889.

We congratulate you on the splendid production you publish; it is in every way creditable.

THE EUROPEAN MAIL.

BACK NUMBERS TO BUY AND SELL.

Havana, N. Y., Nov. 17, 1889.

To the Editor of the Jewelers' Circular:

In looking over my files since 1880, I find that I have lost the Feb. 1882 number, and that I have duplicates from April, '83 to Oct. '83, inclusive. I would like to exchange with some one who has the missing number and dispose of the remainder. I like to have the years complete, as they are very valuable for reference.

W. L. HOPKINS.

Lindsay, Ont., Nov. 16, 1889.

To the Editor of the Jewelers' Circular:

Can you furnish us the following numbers to replace lost ones. June, '88 and Sept. '89.

BRITTON BROS.

Lexington, Ky., Nov. 19, 1889.

To the Editor of the Jewelers' Circular.

I would like to buy a copy of THE CIRCULAR for March, 1883.

J. JONES.

A TENACIOUS SOLDER.—An account is given in the *Berliner* of a soft alloy which adheres so firmly to metallic, glass, and porcelain surfaces that it can be used as a solder, and which, in fact, is valuable when the articles to be soldered are of such nature that they cannot bear a very high degree of temperature, the composition consisting of finely pulverized copper dust, which is obtained by shaking a solution of sulphate of copper with granulated zinc. The temperature of the solution rises considerably, and the metallic copper precipitated in the form of a brownish powder—20, 30, or 36 parts of this copper dust, according to the hardness desired, being placed in a cast iron or porcelain-lined mortar, and well mixed with some sulphuric acid having a specific gravity of 1.85. To the paste thus formed are added 70 parts by weight of mercury, with constant stirring, and when thus thoroughly mixed, the amalgam is well rinsed in warm water to remove the acid and then set aside to cool; in ten or twelve hours it is hard enough to scratch tin. On being used, it is heated to a temperature of 375° C., and when kneaded in an iron mortar becomes as soft as wax; in this ductile state it can be spread upon any surface, to which, as it cools and hardens, it adheres with great tenacity.

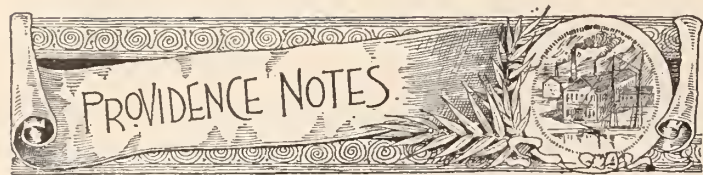

[FROM OUR SPECIAL CORRESPONDENT.]

PROVIDENCE, R. I., Nov. 20, 1889.

Business has commenced to ease off again, and orders are already beginning to come in more slowly than they have for the past six weeks, although some leading houses have a surplus of orders on hand still. The great majority, however, have already commenced to be a trifle dull, but though not so much so as a year ago, when nearly all concerns were on short time with very few orders on hand. Business this fall has been above the average in tone and amount done, and as a general thing, manufacturers are well pleased. Money has eased up considerably during the past month, and failures are not worth mentioning.

Tilden, Thurber & Co., the Westminster street jewelers, have put in the incandescent electric light throughout their extensive establishment which now presents a very attractive appearance. The improvement is appreciated by their many patrons in the city as well as outside.

The co-partnership heretofore existing between Davis & Emerson has been dissolved by mutual consent. The business will be continued by Mr. Emerson under the firm name of Samuel J. Emerson & Co., at the old stand, with a New York office at 191 Broadway.

The Gorham Manufacturing Co. has furnished mine host Humphreys with a new silver service, of some 2,000 pieces, for the Narragansett dining-room.

Hamilton & Hamilton, Jr, the manufacturers of rolled plated chains, No. 7 Eddy street, are distributing a little advertising novelty in the form of a pocket memorandum slate bearing their name and trade mark. It is handy, useful and durable, and will, no doubt, serve its purpose well.

R. A. Kipling, the popular stone importer, arrived home from Paris per the fast French liner *La Bretagne* on the 25th ult., after a pleasant voyage. He brings many novelties which will prove interesting to his many patrons, and the trade generally. Mr. Kipling is an expert buyer in all lines of precious stones.

W. H. Luther was re-elected as President of the "Pomham Club" at their last dinner held recently. The club is composed mostly of manufacturing jewelers which accounts for its finances being in the most flourishing condition at this end of the season.

W. Braitsch, of Hearn & Braitsch, the umbrella and cane head makers, has fully recovered, and is again about and attending to business.

John C. Harrington, who assigned recently to George L. Vose, has liabilities of about \$6,500, and assets of \$2,500. He offers 20 cents on the dollar.

The manufacturing jewelers of this city were affected to the amount of \$2,200 by the failure of Z. Auerbach, of Montreal.

The fine and extensive plant of the Gorham Manufacturing Co. at Elmwood is fast approaching completion, and the early part of the New Year will find them pleasantly located in the most complete quarters to be found in the United States, not excepting those of the Waltham Watch Co.

Speaking of hoop earrings reminds me that W. A. Beatty & Co., 62 Peck street, will fully sustain their reputation in this line next season. They claim to be the largest manufacturers of these goods in the country.

Hancock, Becker & Co. are busily engaged on their new line of white stone goods for the spring trade, to which they have added a line of fancy stone rings in new and desirable patterns.

Representatives of the press will please give No 409 Pine street

a wide berth for the present. "Barney" is closeted in his sanctum hard at work on the new line of samples that Crossin & Tucker are going to dazzle the trade with on January 1st. The embargo will doubtless be removed about December 5th, when "Barney" will again be at home to his friends of the press, who will then have the opportunity of taking revenge on him by indulging in a few hyperboles over those handsome new goods that are sure to be the result of his labors.

B. F. Merrill has moved from No. 40 Sutton street to No. 113 Chester avenue.

Howard & Son have offered a prize for pupils of the Rhode Island School of Design.

The New England Manufacturing Jewelers' Association will hold its annual banquet in Tillinghast's Assembly Rooms on Tuesday, the 19th inst, at 8 P. M.

Edward Holbrook, Treasurer of the Gorham Manufacturing Co., registered at the Narragansett on Wednesday last.

Horace F. Steere, connected with T. F. Arnold, has received a windfall of \$25,000 in cash and a fine residence on Benefit street, by the death of Henry J. Steere

E. W. Martin, of Messrs. Martin, Copeland & Co., was a special guest at the meeting held by the Boston Jewelers' Club at Young's Hotel on Saturday evening last, where speeches and stories were the order of the evening after the regulation dinner, for which Young's is celebrated, was disposed of.

George E. Barnaby, manufacturer of gold and silver headed canes at No. 96 Pine street, under the firm name of George E. Barnaby & Co., has made an assignment to C. J. Mulvany. Mr. Barnaby succeeded the firm of E. A. Luther & Co. about June, 1888. The firm has been financially straightened for some time.

W. E. King has gone South, and closed out his business to Lewis Patstone. Ill-health was the primary cause.

Fred. I. Marcy was re-elected President of the Sons of Vermont on Friday last.

F. V. Kennon & Co. have dissolved by mutual consent the co partnership which formerly existed between them. B. A. Whitcomb succeeds to the business and assumes all liabilities.

R. A. Greene & Co., No. 180 Friendship street, have succeeded the two former concerns of W. S. Greene & Co. and R. A. Greene & Co. in a total consolidation of interests, and will continue the business.

The firm of Tillinghast & Mason has been dissolved by mutual consent, John L. Mason retiring on account of ill-health. The new firm name will be C. P. Tillinghast & Co., and will continue at the old number.

Hon. Hiram Howard captured the majority of the delegates at the Democratic caucusses held on Thursday evening last at the several ward meetings, who voted for him nearly solid as being the proper representative of the party to run for the office of Mayor at the coming election of city officers for the ensuing year. Mr. Howard gave his final decision on Monday, the 18th inst., accepting the nomination.

O. C. Devereux is meeting with great success in the sale of his white and black pearl goods.

Kent & Stanley are filling many foreign orders for their celebrated seamless filled gold chain, and now employ a larger number of hands than almost any other manufacturer in the city.

George W. Hutchison and family have arrived home from Bath Beach, L. I., where they passed an exceedingly pleasant summer and fall.

C. Anthony Fowler, of Fowler Brothers, was registered at the Narragansett the past week.

Flint, Blood & Co. have no reason to complain of the patronage extended to them the present season on their line of gold-filled and plate rings in fancy and unique settings, with both real and imitation stones.

Hiram Howard, of Howard & Son, takes a warm interest in the

cause of industrial education. He was one of the original founders, and has been one of the staunchest supporters of the Rhode Island School of Design, and in him John Ward Stimson, of New York, the eminent advocate of the cause of the artist artisan, has found an admirer and friend. Mr. Howard is arranging to have the teachers of our Rhode Island school pay a visit to Mr. Stimson's Institute for Artist Artisans at his expense. The visit will be made about Thanksgiving time, and a thorough inspection of Mr. Stimson's admirable methods will no doubt yield much in the way of encouragement and suggestion for our own workers in this field.

Fred. I. Marcy & Co. report a brisk and constantly increasing demand for their "Eiffel" collar button, which has an enamel back that prevents discoloration and poisoning of the neck.

Thurber & Burns, formerly in the employ of Hutchison & Heustis, will shortly start in business for themselves at 195 Eddy street, manufacturing a line of gold stone rings, and dealing directly with the retail trade,

Kirby, Mowry & Co., ring makers of 117 Harrison street, have just completed some improvements in their office rendered necessary by the increasing volume of their business.

FAIRFAX.



[FROM OUR SPECIAL CORRESPONDENT.]

BOSTON, November 17, 1889.

The business situation here isn't as settled as it might be, as, indeed, it ought to be at this season of the year. There is a curious element of uncertainty as to the holiday outlook and the conservative opinion is that the year will go out with no very remarkable activity in any line of trade.

And yet most of the signs are fairly favorable. A generally quiet, but firm money market, a more active and stronger market for stocks, with the exception of those of the Trusts, and a gradual Fall increase in the volume of trade at large have been the main features of the business situation during the last week or ten days. A return flow of money from the West and South is hoped for, yet men of affairs are inclined not to build too largely upon this hypothesis, as, with the present reported activity of traffic in those sections, no actual relief may be reasonably expected until after the first of January.

The moneyed people of this section—those who live on the back bay and cut off the coupons of luxury with the shears of investment, are most of them anxiously awaiting the issue of the the two months trial of the Atchison re-organization plan, the announcement of which so rattled the financial world not long ago. It's odd to notice how potently these big upheavals of speculations influence the general temper of the community, but those who deal in the sale of luxuries can appreciate the resulting stringency for liberality on the public purse at large.

The Ripley Howland Company voices the general sentiment of the conservative jewelry trade in reporting business good but not heavy. You will find little effort to exaggerate things among the standard houses and the estimate of this concern is representative.

D. C. Percival & Co. have also done a good business right along and expect a continuation of it until the new year sets fairly in. They regard this steady moving along as more promising in many respects than an exhausting boom that leaves the market temporarily paralyzed.

Floyd, Pratt & Rounds report that more goods have gone out over their counters this month than last, and so they are little disposed to

complain. They seldom do have any cause for discouragement because of dullness.

Tufts & Co. say they have had a steady, good trade, but it is not heavy, and expect next month to be their busiest one. This is rather an off month they think. They have sold large orders to the big jewelers in town and have stopped selling to such firms as Jordan, Marsh & Co. They think that by selling only to the legitimate jewelers their trade will increase. It deserves to on that ground alone.

The evening of Saturday, November 9, will be favorably remembered by the sixteen members of the Boston Jewelers' Club, who met at Young's Hotel and entertained as guests of the organization, Mayor A. C. Titcomb, of Newburyport, and E. W. Martin, of Boston. President Harwood was the official host and the entertainment was enjoyably informal.

The Alexander Company, jewelers and silversmiths, who opened their store about the middle of September, are doing well. They report trade as not very rushing, but there seems to be a pretty steady stream of it. They cater to the upper class in Boston. A description of their beautiful store on West street, may be interesting. It is furnished in the old colonial style of light paint and frescoes, and the general appearance is cheery and business like. A new departure in the matter of show cases is one of the features of the new establishment. They carry out the idea of the other fittings and are of solid mahogany, square, and very deep, thereby giving the goods much better showing. The cases rest on tables with massive legs. Another good feature is the diversion of the store by means of a *partierre*. In the rear apartment is a very heavy, solid mahogany table, covered with a beautiful silk damask cloth. When a number of persons come in and ask to see silverware, the curtain is drawn, chairs are drawn around the table and the ware is set out on the damask, which adds to the beauty of the silver. This company carry only the finest stock, mostly solid ware, and the only plate kept is Gorham ware. Mr. Alexander, the head of the company, was, for many years, in charge of the solid silver department at Shreeve, Crump & Low's, and has a thorough knowledge of the business.

President Charles H. Harwood, of the Boston Jeweler's Club, and also of the firm of Harwood Brothers, said that this month trade had not been quite so good as was expected, not so good in fact, as last year. He thought that next month trade would pick up.

Shreeve, Crump & Low say that trade this year is not as brisk as usual, yet it cannot be called poor by any means. There has been a steady stream of purchasers, with a small one. They say as do the others that next month will bring out the buyers in large numbers. They are offering a novelty in the jewelry line in the shape of moonstone brooches, which are made in an infinite variety of shapes and are very popular.

George H. Richards, Jr. says that trade has been fair and that is all. It cannot be called good and it cannot be called bad. It has been an off month. Dealers buy their October bill and then wait until December before they purchase any more goods. This year's trade seems to them a little duller than last.

A. H. Potter & Company say that the general impression is that this year trade has been a little dull, but when the books are compared about the same figures after all are found. But last year at this time business was not at all brisk, and this year it is no better. The holiday trade will of course be large, but it has not yet begun.

The outlook now is for a rather late beginning of the regular holiday trade.

The creditors of Charles P. Vaughan, of Hyde Park, met at the Boston store of H. T. Spear & Son, on October 22d. A. T. Sylvester was chairman and W. H. W. Pratt secretary. Assignee Alexander Miller stated the liabilities at \$5,332.10; assets, \$6,531.54. D. C. Percival, E. B. Floyd and George H. Whitford were appointed to look after the closing up of the business. A fair dividend is looked for by the creditors.

Jeweler S. Henry L'Heureux, at 2400 Washington street, displays

J. EUGENE ROBERT.

A. WITTAUER.

J. EUGENE ROBERT & CO.,
Manufacturers and Importers of Watches,
30 Maiden Lane.

SOLE AGENTS FOR

LOUIS AUDEMARS.

JULES MONARD.

AGASSIZ WATCH CO.

LONGINES WATCH CO

PLAIN AND COMPLICATED WATCHES.



GRAND PRIZE, PARIS, 1889.

New York, October 15th, 1889.

To the Trade:

We take great pleasure in announcing that

LONGINES WATCHES

so favorably known have obtained the Highest Award

THE GRAND PRIZE

at the Exhibition of Paris, 1889.

In making the announcement we desire to emphasize the fact that this is the first instance in which a similar honor has been awarded to Medium Priced Watches.

Very respectfully,

J. EUGENE ROBERT & CO.,

SOLE AGENTS and IMPORTERS.

J. EUGENE ROBERT.

A. WITTMAYER.

J. EUGENE ROBERT & CO.,
Manufacturers and Importers of Watches,
30 Maiden Lane.

SOLE AGENTS FOR

LOUIS AUDEMARS.

JULES MONARD,

AGASSIZ WATCH CO.

LONGINES WATCH CO.



GOLD MEDAL, PARIS, 1889.

New York, October 15th, 1889.

TO THE TRADE:

We beg to announce that a

GOLD MEDAL

was awarded to the

AGASSIZ MOVEMENTS,

exhibited at the Paris Exposition, 1889. This success is the more remarkable as the Agassiz Factory has been in existence but twelve years, and has exhibited on only one occasion prior to the present.

Very respectfully,

J. EUGENE ROBERT & CO.,

SOLE AGENTS AND IMPORTERS.

an oxidized silver medal of the oldest house in New England. The work is in *bas relief* with an oak frame. The house is the old Cradock mansion that stood till about a year ago facing upon the main street in Medford, this state.

The month of October contributed some elegant weather to the trade, and weddings flourished encouragingly.

Antique art of the Puritan order is becoming fashionable here.

Speaking of the old Cradock house reminds me that John A. Remick, of 20 Tremont street, has just bought another of those architectural landmarks with which our New England towns are plentifully sprinkled. His is the old Tristram Dalton mansion at Newburyport. It was built in 1730. Its original owner was one of the first senators to the Federal Congress. Mr. Remick will use the estate for a summer residence.

New York people will readily remember George T. Reed who used to be with Tiffany & Co. He is now President of the Arena Publishing Co. here. The Arena is a magazine of the Forum variety, and makes a most attractive appearance.

George E. Lyford & Bros. have closed up their entire business. It was started in 1836, and is now gone into completed history.

Springfield people are interested in the rumor of an early establishment there of a new silver and plated ware factory.

Albert R. Kerr, of William Kerr & Son, 39 Hanover street, was married on October 11th to Miss Lavonia Howes, of Somerville. The couple are spending their honeymoon in Montreal.

The silverware factory of the A. F. Towle & Son Co. has been removed from Newburyport to Greenfield.

Irving Smith, of Morrill Bros. & Co., returned last month from Europe.

The proper thing in Boston now is to have H. N. Lockwood photograph one's dearest friend or relation upon a watch cap. Lockwood has a monopoly of the process which resembles that by which designs are burned upon porcelain. The portraits cost \$15 each, and there are a good many of them worn in the Beacon Hill clubs nowadays.

The Boston Ideal Novelty Manufacturing Co. has located at 71 Sudbury street, and report business to be already promising.

The retail show windows about town are putting on their best holiday bib and tucker.

Josiah Cummings, of the firm of Josiah Cummings & Son, manufacturers of jewelers' trunks and sample cases, 109 Summer street, is traveling in the West and meeting with good success selling their patent steel trunk. This trunk being made of a fine grade of spring steel, is very light and durable, and is giving general satisfaction.

LEON.



[FROM OUR SPECIAL CORRESPONDENT.]

PHILADELPHIA, Nov. 15, 1889.

Leon J. Dutton, formerly with Sigler Bros., Cleveland, O., has taken the road for the Keystone Watch Co., Lancaster, Pa. Mr. Dutton has had many years' experience in the watch business and is very popular among the retail trade. With Mr. Cain in the mechanical department, and Mr. Dutton in the commercial department, the Keystone Co. has greatly strengthened its position, and all interested feel encouraged with the outlook.

The contract between Atkinson Bros., general agents for the sale of the Keystone watches and the Keystone Watch Co., has been modified, and the company will henceforth have the right to sell direct to the jobbing trade. Atkinson Bros. will still make a specialty of the Keystone watch, however.

Atkinson Bros., 931 Chestnut street, have secured on very advantageous terms a large lot of the "Anti-Pickpocket Swivels," illustrated elsewhere in this issue, which they are offering to the trade at bargain rates. In fact they handle nothing but bargains.

Some time since one of the manufacturers visiting the store of B. J. Cooke's Sons, on North Third street, said, to coin a word, it was the "*clockiest*" store he had ever entered. They still maintain that reputation, as they display the goods of all manufacturers, not of one or two only. The business of the past three months has been very satisfactory with them, and as the time for the rush for novelties and fine goods is approaching, they have every reason to believe that the best is yet to come and are fully prepared for it.

One of the handiest and most useful books of instruction for the optician is published by Jas. W. Queen & Co., the celebrated Philadelphia optical house, and is entitled "How to Fit Glasses." It has been prepared by one of the best oculists, and is replete with information of value not only to the beginner, but to any one fitting glasses. Queen & Co. do not commit the error of claiming that this or any other method of instruction is all that is necessary to make a good optician. The subject is too extensive to be gained by a short term of study. There are so many branches of it that the best that can be done in a work of this kind is merely *to open the way* to a young student for future and more comprehensive study. There are few persons who will commit the error of supposing (when men of the best practical ability require years to master the subject, and have taken courses in colleges and eye clinics, not only in America, but in London and Vienna), that anything but the merest smattering of the subject can be obtained in the manner above referred to. One great feature about "How to Fit Glasses," is that it contains illustrative cases, plainly and fully described, which are found to aid the optician more than almost any other part of the book. It gives one or two cases where presbyopia, or old sight, the most common difficulty which an optician is called upon to correct, is easily diagnosed. This is but a small number of the cases described, and such cases embrace hyperopia, myopia, or near sight, astigmatism, etc., etc. The price of this work is 75 cents. Queen & Co. also publish a large quantity of material, which is intended to aid the optician in his work, including their complete catalogue, prescription blanks, telegraphic code, phototype cards, descriptive circular of new models, pupilometers, rules, colored charts of the eye, test cards, astigmatic dials, etc., etc. They are also prepared to give information upon and furnish all the necessary machinery and tools for surface and edge grinding on lenses, and the general jobbing which the working optician is called upon to do. Their experience and experimentation covering many years have enabled them to adopt the correct forms of machinery and the proper quality of material necessary in each case.

David F. Conover & Co. report trade fair, with prospects of improvement as the holidays approach. Their advertisement in THE CIRCULAR is bringing a good many requests for their new material catalogue for 1890.

Hollinshed Bros., 806 Chestnut street, are now getting accustomed to their enlarged quarters, and find themselves in better shape to handle their growing business. The chain which they illustrated in the last CIRCULAR as the best in the market for its price, is meeting the unqualified approval of the trade everywhere, and large sales are bobbed.

Simons, Bro. & Co. presented a gold thimble to each lady in the Pan American delegation as the party were leaving the Continental Hotel.

At a recent meeting of the Philadelphia Retail Jewelers' Association, it was resolved to form a State organization and to change the name from the Philadelphia Retail Jewelers' Association to the Pennsylvania Retail Jewelers' Association. A convention at which all the jewelers in the State are requested to be present is to be held here January 2, 1890. Delegates from jewelers' associations in neighboring States will also be invited. A committee consisting of Arthur S. Goodman, Jos. W. Forsyth, W. H. Long, J. Henry Gerke and John Bates was appointed to draft a constitution and by-laws for the new organization, and it was decided to rent larger quarters at 1,128 Arch street.



TRADE GOSSIP.

—The address of W. Woolsey, now of Pass Christian, Miss., after Dec. 12, will be Lake Charles, La.

—Wm. D. Ward has moved from Stoughton, Mass., to Hyde Park, same state, where he has purchased the business of C. P. Vaughan.

—The new catalogue of Charles Jacques 2 Maiden Lane, New York, is a complete and valuable book for jewelers to consult when about to order fine imported clocks. Retailers should send their cards for a copy.

—Leroy W. Fairchild has been honored by President Carnot of France with the cross of the Legion of Honor, conferred as an additional reward for the excellence of the Leroy W. Fairchild Company's exhibit at the Paris Exposition.

—D. F. Foley & Co., 23 Maiden Lane, New York, are doing a lively business which is not surprising when we examine their choice array of the finest pens and holders, including solid silver holders, chased, oxidized and etched. This firm has arranged especially for the jewelry trade, numerous show case and tray assortments, which are receiving the appreciation justly due them.

—The Metropolitan Museum of Art, which was opened on Nov. 4, for the winter season, has received from Mrs. J. W. Drexel, a new and valuable collection of objects in gold, silver, enamel, pearl, jewels, etc.; from Miss Sarah Lazarus, a new collection of miniatures, boxes of gold, crystal, enamel, and other material, jeweled watches, and ornamental fans, and from Mrs. S. P. Avery, to her former loan collection of the same nature, a large number of antique and Oriental spoons in silver.

—We call the attention of our readers to the advertisement of F. J. Kaldenberg & Co., of 211-229 East 33d street, New York, manufacturers of fine walking sticks and smokers' articles of every description. Every jeweler can handle these goods, and those who do so, find their sales of jewelry much increased. In these days of intense competition, this fact should be carefully considered. We may say that the goods manufactured by Kaldenberg & Co. are of a high-class and show plainly that an artistic and cultivated taste presides over this establishment. Their stock of ivory goods can be specially commended.

—P. F. Egan, St. Paul, Minn., announces his intention of quitting the jewelry trade and engaging with his brother in the more congenial theatrical business. He is closing out in consequence. The history of his establishment is quite interesting. It was founded by D. C. Greenleaf, in 1853, and was the first jewelry store in the young city. In 1866, Mr. Egan became the founder's apprentice and remained with him as workman, etc., until 1876, when Mr. Greenleaf died and Mr. Egan became his successor. The business has prospered from its establishment, not having been closed a day outside Sundays, holidays, etc., since 1853.

—The Wm. Rogers M'fg Co., Hartford, Conn., have purchased the plant of the Wickersham Horse Nail Co., of Norwich, Conn., and are fitting it up with all the modern appliances necessary for the manufacture of solid steel blanks, carvers, etc. The plant is very conveniently situated, with 400 feet of wharf on one side and 400 feet of railway on the other, and comprises three buildings, the power being furnished by a 150 horse power engine. The name of the Norwich branch will be "The Norwich Cutlery Co.," and as a result of its acquisition the Wm. Rogers Co. will be enabled to largely increase their production and effect a saving of expense for their customers' benefit. They expect to start up about January 1st, with 100 hands.

—On Nov. 13, Charles E. Merritt, a young inventor of considerable promise, died at his home in Springfield, Mass. He was the youngest son of Samuel F. Merritt, the well-known manufacturer of eye glass holders, and was born in 1861. At an early age he evinced a marked taste for fine machine work, and as years passed became an inventor and perfecter of light machinery. He was at one time in the employ of Smith, Lesquereux & Co., and re-organized their spectacle factory for them. His principal work was in light button machinery and in typewriting, his inventions in the latter made him one of the most prominent men in the trade. The deceased was a favorite with mechanics, and will be much missed.

—The dates of the Second Annual International Fair of the Detroit International Fair and Exposition Association, to be held at Detroit, Mich., have been determined upon—August 26th to 31st inclusive and Sept. 2d to 5th inclusive, 1890.

—Frank Mauser & Co., North Attleboro, Mass., are running day and night to overtake orders. Every first-class retailer should have some of their goods for the holidays. Mr. Mauser will be in New York during the month of December, to attend to the wants of their customers there, and also in Philadelphia and Washington.

—B. & W. B. Smith, the widely known manufacturers of show cases, architectural wood work, etc., report their trade very good among the jewelers and silversmiths. They have within the last month taken orders for their counter and wall cases from T. Kirkpatrick, Jacques & Marcus, Theo. B. Starr, Gorham M'fg Co., Whiting M'fg Co., Simpson, Mall, Miller & Co., Pairpoint M'fg Co., J. B. and S. M. Knowles, C. Schumann & Sons, Middletown Plate Co., American Waltham Watch Co., B. S. Wise, all of New York, and also from J. E. Caldwell and Co., Philadelphia, Pa., C. L. Byrd & Co., Memphis, Tenn., Fred. N. Day, Oxford, N. C., C. G. Rochat & Co., Jersey City, N. J., Phillips & Armitage, Jamestown, N. Y., Cowell & Hubbard Co., Cleveland, Ohio, F. F. Bonnet, Columbus, Ohio, and several others. They are making handsome designs in wall cases and have many novelties in small cases. Their counter cases are simply elegant. The firm have enlarged their factory to meet the increasing demand.

—The Pairpoint M'fg Co., New Bedford, Mass., have just issued their new illustrated catalogue for 1890, a handsome book of 212 pages, enclosed in an attractive cover of linen-backed leatherette. The leaves of the book are of fine super-calendared paper, the printing being handsomely done in photographic ink, which brings out the beauties of the numerous articles to advantage. Though over 1,000 designs are illustrated, the company's full line is not represented, a selection having been made of such patterns as have proved most desirable to the trade in the past, together with what new ones were ready at the time of going to press. A complete specified list of the 117 various lines of goods depicted would bewilder the reader; suffice it to say that numerous specimens of every variety of hollow and flat wares and several lines of small wares, such as match boxes, bonbon boxes, etc., are given. In the flat ware we would call especial attention to the beautiful new "Garland" pattern for hollow handles which is used in fancy pieces only; also, to the hand engraved "miseltoe," "myrtle," "ivy," and other pretty patterns. Several lines are put up in handsome satin-lined silk plush cases which are made at the company's factory. Numbers, descriptions and prices are given under each piece, besides the complete price lists for the flat ware and separate plush cases. The company are constantly increasing their facilities and rapidly adding to an already extensive stock such goods as will suit the present advanced taste of their patrons. Samples of this and attractive salable stock can be seen at their showrooms, 20 Maiden Lane, New York, 90 Wabash avenue, Chicago, and 220 Sutter street, San Francisco.

—One of the handsomest catalogues which THE CIRCULAR has received this season is that of the R. Wallace & Sons Manufacturing Co., manufacturers of sterling silver and plate, Wallingford, Conn. Printed on fine coated white paper, the illustrations do credit to the magnificent lines of goods represented. Though most of the goods depicted consist of flat ware of every description, numerous small wares—scissors, shoe horns, peppers, salts, mirrors, match and stamp boxes, bonbonnières, powder boxes, glove hooks, etc.—are also displayed. Combinations such as ice cream, fish, coffee spoons, manicure, carving and other sets, and single pieces in handsome plush cases are largely shown, in reference to which we quote from the introduction "while those represented can be furnished immediately, many other combinations are constantly being added and kept in stock." The majority of the pieces illustrated are in sterling silver, $\frac{9}{10}$ fine, the remainder being in nickel, silver, silver soldered and plated. The catalogue will be furnished to dealers upon application. The representative of THE CIRCULAR, when he visited the company's show rooms at 21 Park Place, New York, inspected the articles and was impressed by their style and finish. A noticeable novelty seen was a line of cheese scoops in silver with fancy handles variously designed in Wechsler wood with silver deposit ornamentations. On January 1, the show rooms will be removed to 3 Park Place (1 door off Broadway), where much more spacious quarters have been secured. The new rooms will be elegantly fitted up at a large expense, double rows of fine wall cases, etc., being installed. B. & W. B. Smith, have the contract for the architectural and case work—a guarantee that the store will be of a sumptuous character.

—The J. Steinmetz Jewelry Co. are the successors of the W. G. Bailey Jewelry Co., Helena, Mon.

—George H. Houghton, of the Gorham Manufacturing Co., sailed for Europe, Nov. 23 by the steamer *La Champagne*.

—George W. Clough, formerly with Wise & Son, Brooklyn, N. Y., is now in the employ of E. A. Thrall, 3 Maiden Lane, New York.

—C. Dorflinger & Sons, 36 Murray street, are showing two new patterns in rich cut glass, the "Columbia" and the "Crystal," the latter being a perfect imitation of chased silverware.

—The Hartford Silver Plate Co., Hartford, Conn., are running over time to fill the orders for their reliable hollow ware, which is becoming better appreciated by the trade every day.

—We are in receipt of a pretty advertising conceit from Hukins Brothers, Syracuse, N. Y. It is an 18 leave little book about 2½ inches square. On each leaf is printed a stanza of the well-known poem of natal gems, or a short announcement.

—In accordance with their usual custom, that live firm of jewelers, S. F. Myers & Co., 48 Maiden Lane, New York, will present to each of their employees for their 1889 Thanksgiving dinner, a fine turkey, 1,500 pounds of choice Connecticut poultry having been ordered for that purpose.

—Koch & Dreyfus, 22 John street, have bought out the entire stock of the improved No. 60 watches made by the Trenton Watch Company, and are offering them at greatly reduced prices. The trade are requested to send for special price list, as this is claimed to be one of the best bargains in low-priced watches ever offered to the trade.

—The Cumberland, (Md.), *Workman* contained in an issue last month a lengthy complimentary notice on the stock of F. W. Johnson of that city. It said in the selection of his stock he has shown rare judgment and exquisite taste in all its branches. His stock of all goods will be found as the market demands and every novelty is introduced upon its appearance in the wholesale market.

—The father-in-law of William Oskamp, of Oskamp, Nolting & Co., Cincinnati, is the great millionaire soap manufacturer, M. Werk. He is one of the richest merchants in the State of Ohio, and now enjoys the hale old age of 84 years. The relation between M. Werk and William Oskamp is one of great intimacy, and there is no doubt that Mr. Oskamp will roll in some of the millions one of these days.

—Jos. Noterman & Co., 203 Race street, Cincinnati, are greatly pleased at the outlook for the holiday trade. Their office presents a bustling scene. Large orders are being filled for their Olympus diamond goods, and judging from the artistic style and high finish of these goods, one can at once see the reason for the unusual demand for them. The firm also have a heavy call for their diamond work.

—In the line of fancy goods and articles of utility which progressive jewelers are now adding to their stock, such goods as table kettles and stands, umbrella stands, cuspadores, crumb scrapers and trays, ornament stands and the like, handsomely designed in polished brass, nickel plate and antique silver, should have a conspicuous place. The John C. Jewett Manufacturing Co., Buffalo, N. Y., manufacturers, have issued especially addressed to the jewelry trade an appendix to their catalogue beautifully illustrating these articles.

—The remarkable popularity with which miniature brooches and necklaces have met for some months, is unabated. John A. Riley, 860 Broadway, New York, has made, this season, a specialty of these lines, and light can be seen nightly at the factory until 9 o'clock, showing that he is busy turning out large quantities of the goods in addition to his regular lines. In bracelets, Mr. Riley has prepared numerous new designs to meet an unusually good demand. These bracelets are of the flexible variety, and are made in 14-k. gold, some being gemmed.

—Delmonico's was the scene of a brilliant wedding on the evening of Nov. 14. At six o'clock Rabbi Gottheil, of the Temple Emanu-El, united Miss Rosalie Lissauer to Dr. Leon N. Adler. The ceremony took place in the red room, and after the young couple had received congratulations, a dinner was served in the ballroom at small tables. Fourteen ushers officiated—Messrs. Max Kallman, Martel Mirabeau, Millard F. Adler and Richard I. Adler, brothers of the groom; Julius B. Schloss, Joseph Pronick, Alfred Apler, Frank Adler, L. Sondheim, Maurice Kaufman, A. Weil, Dr. M. Lazarus, Harry Heiltsun and Leo Schwab.

—Commenting in our last issue upon the beautiful new pattern, "The Flora," now offered to the trade by George W. Shiebler, silversmith, of No. 8 Liberty Place, the types stole a march on us and transformed "Flora Teas" into Flora Tears, a very Niobe of patterns forsooth. To any who may be inclined to condole with Mr. Shiebler over the lachrymoseness of the situation, we can say that the tears are the printer's, not his. In the manner in which the trade are taking hold of this new pattern, he finds no cause for tears.

—THE CIRCULAR acknowledges the receipt from the publishers, G. P. Putnam's Sons, of a copy of a book entitled "Precious Stones," by M. D. Rothschild, importer of precious and imitation stones, 41 Maiden Lane, New York. Mr. Rothschild's aim in preparing this book has been to provide a thoroughly practical work of reference for dealers and amateurs, which should be free from technicalities, furnish practical tests of approved value, and give in condensed form all the information the jeweler and expert will find of working value in his calling. We recommend it to all who need a handy work of reference.

—The well-known house of J. T. Scott & Co., 4 Maiden Lane, New York, has issued an attractive 8-page pamphlet, calling attention to some of their specialties. The first four pages refer to their celebrated anti-swear cuff buttons, and contain general information of their construction, a page of patterns in which the buttons are made, testimonials and illustrations demonstrating the action of the button in taking it out and putting in the cuff. The other page displays numerous patterns in diamond goods, prices, descriptions and illustrations of the widely known "Leader" chronographs and several handsome designs of watch cases.

—The Julius King Optical Co., 4 Maiden Lane, and Cleveland, Ohio, notify the trade in this issue of THE CIRCULAR, that they are the sole licensees of the only genuine opera-glass holders, patented by Judge Mack, Terre Haute, Ind., Nov. 28th, 1882, and March 12th, 1889. On account of the popularity of these holders, it is claimed that imitations are being placed upon the market, and the trade are, therefore, cautioned against buying or selling any but the genuine article, of the sale of which the Julius King Optical Co. have the exclusive control. One suit for infringement and damages has been commenced by them, and others will follow.

—After a protracted illness S. F. Hobbs of Selma, Ala., breathed his last on October 26. Mr. Hobbs was one of Selma's most progressive citizens, who was always to the front in public enterprises, looking to the city's advancement. He went to that city in 1856 and bought out the jewelry business of a Mr. Poor. In 1863 he enlisted as a soldier in Captain Tom Goldsby's company of Confederate cavalry. In 1865 he re-established his jewelry business in Selma. He was active in reorganizing the Matthews cotton mills in 1879, and in 1884 he moved to Aurora, Ill., where he became the secretary of a large cotton mill. A short time since the deceased returned to Selma, where he resided up to the time of his death.

—Queen & Co., the great optical house of 924 Chestnut street, Philadelphia, have been experimenting with bi-focal lenses for the past two years, and with such good success, that they are now prepared to offer them to the trade in a thoroughly practical shape. They furnish these goods in many different forms, a number of which are illustrated in their advertisement on another page. In workmanship and finish, these bi-focal lenses are in keeping with the high reputation the house of Queen & Co. enjoys. Their book, entitled "How to Fit Glasses," a useful compend designed to enable any person of ordinary ability to obtain practical information about the correct fitting of glasses, can be unhesitatingly recommended to all in search of a work at once simple, practical and complete.

—S. F. Merritt, Springfield, Mass., has just introduced a novelty which undoubtedly will become very popular among ladies. It is a combination eye glass chain and hairpin, and in construction is both useful and pretty. The salient feature of the novelty consists of a sliding device attached to the end of the chain, and which is intended to be slid on the prongs of the hairpin. The hairpin is practically independent from the chain, the latter passing through a loop at the top of the pin, but is prevented from being detached by the sliding attachment which is larger than the loop. When the hairpin is placed in the hair, and the slide on the prongs, the greater the pulling on the chain, as will be readily understood, the firmer the pin remains and the less the liability to become loosened. The slide may thus be made as ornamental as desired, for so long as the eye-glass end is safely attached, the risk of loss is reduced to a minimum. This pretty novelty is made in 14-k. gold, rolled-gold plate, oxidized and plain silver, etc. The manufacturer will cheerfully send dealers samples upon application.

—L. Sheridan has opened a jewelry store at St. Charles, Minn.

—K. F. Woodard has opened up a jewelry establishment at Wells, Minn.

—W. H. Hubbard has located at Paynesville, Minn., in the jewelry business.

—H. C. A. Sedgerbloom has removed his stock from Sank Rapids to Motley, Minn.

—C. B. Morse & Co. are preparing to open a jewelry store at Chipewa Falls, Wis.

—D. B. Gordon has recommenced business at Rock Hill, S. C., as agent for Mrs. L. A. Gordon.

—Fritz Mathez, of Mathey Bros., Mathez & Co., importers of watches, sailed for Europe on Nov. 30th, by *La Belagnè*, on a business trip.

—Fred. O. Fisk, formerly with A. C. Clausen, with an "& Co." added, has opened a new jewelry store at 26 Washington avenue South, Minneapolis.

—John Steinmetz, Morgan F. Lewis and Charles B. Garrett, have incorporated the "J. Steinmetz Jewelry Co." at Helena, Montana. It is stocked for \$50,000 in 500 shares.

—Warner & Co., Minneapolis, have removed to better quarters at 302 to 304 Nicollet avenue. F. J. Barnhart, formerly with Rosenkranz & Thatcher, of Milwaukee, is now traveling with them.

—Crane Brothers, jewelers, have added so much to their stock that an addition to their store was in order. They now have the finest jewelry establishment, probably, in the part of Minnesota round about Lake City.

—J. B. Wood, buyer for Charles F. Wood, 169 Broadway, New York, arrived from Europe last month, on the *Servia*, having purchased large quantities of the specialties dealt in by this firm—viz., colored and fancy stones.

—E. C. Moore, of Tiffany & Co., was last month honored by President Carnot of France, with the Cross of the Legion of Honor, as an additional distinction to the many prizes awarded the firm for their displays at the Paris Exposition.

—The many friends of Mr. S. C. Scott, of J. T. Scott & Co., 4 Maiden Lane, will be pleased to learn of his approaching marriage. On December 12th he will be joined in wedlock to Miss Helen McNaughton, of Sandy Hill, New York.

—One of the largest and finest assortments of precious stones to be found in America may be inspected at the office of Henry Dreyfus & Co., 25 Maiden Lane, New York. The stock includes diamonds, pearls, emeralds, rubies, sapphires and every thing in the line of gems.

—Jewelers visiting New York should not fail to call at the show rooms of S. Klaber & Co., art workers in onyx and bronze, 47 West 42d st., and examine the firm's handsome stock of Mexican onyx tables, pedestals, cabinets, clocks and lamps, especially designed for and adapted to the fine jewelry trade.

—The "mills of the gods" can't hold a candle for slowness to the erection of some government buildings, but after a 10 years' wait, Minneapolis has moved into her new (?) postoffice. A Seth Thomas clock is now being placed in the tower. The bell weighs 1,000 pounds and will strike every half hour, day and night.

—Now that Dakota's a state, she feels that the luxuries are nearer. Flandrau, S. D., is to have a jewelry store; F. Willman and A. E. Hanson, of Stillwater, Minn., are thinking of locating at Pierre, where they are now looking over the ground, and D. G. Gallett has already opened a fine jewelry store there, though he will keep up his establishment at Aberdeen.

—R. & L. Friedlander's new catalogue of watches, jewelry, optical goods, materials, tools, etc., is a most complete and beautiful affair, profusely illustrated and thoroughly descriptive. Every retailer should have copy as a book of reference for from it, almost everything needed by a jeweler can be ordered from it. The volume may be had upon application. The address of the firm is 65 Nassau st., New York.

—During the past month, Carter, Sloan & Co., of 15 Maiden Lane, New York, received a letter from an English syndicate, in which the latter offered to purchase the business at almost any figure, a portion to be paid in cash, and the balance on time, the firm to continue conducting the business for them for three years. The gist of the reply brought forth by this letter was that Carter, Sloan & Co. refused to consider the matter at all.

—Ambrose Webster, of the American Watch Tool Co., was recently awarded letters patent for a tail stock spindle for lathes, whose salient feature consists in its being adapted to receive an adjustable bushing that surrounds the spindle, and to make a rest for its shoulder.

—Among the new tools that O. W. Bullock & Co., Springfield, Mass., are offering to the watchmaker this season, are a combined screw driver and tweezers, a temper remover furnishing a complete protection for heating arbors and without injuring the wheel or balance, and an eye glass stake in which to set spectacles and eye-glasses when removing rust or tight screws.

—An odd case came up lately before a Milwaukee justice of the peace, that of a young swell whose name frequently appears in society items there. Meeting a friend who owns a fine solitaire diamond ring, he remarked, off hand: "I say, lend me your ring till to-morrow; I'm going to a party to-night." The ring was readily handed of and as readily returned next day, but the owner thought the stone unfamiliar, took it to a jeweler, and found that paste had been substituted. He had the swell hauled up before a justice, but allowed the latter to go upon his promising to get the diamond out of pawn within a specified time.

—It is announced that M. Courton, a chemist, produced recently at the sitting of the French Academy of Sciences a sealed envelope containing a description of an apparatus by means of which objects may be seen at vast distances, the vibration of light being transmitted. About four years ago Herr P. Nipkow described his "electrical telescope," an invention based on the same idea, and only a few weeks ago Herr Korzel showed the practicability of the idea by exhibiting to a party of scientists in Berlin the image, received on a glass plate, of a friend who was at that moment speaking to him through a telephone in Potsdam. Edison is also at work on a similar machine.

—The success of the Brooklyn Watch Case Co.'s "Granger" case has been so pronounced that, in the comparatively short time since its introduction—slightly over a year—it has become one of the most popular cases on the market. As is customary when any product has proved successful, imitations of this case, inferior in quality and finish, have appeared. To protect the trade, the Brooklyn Company announce that all these cases which are made in 18, 16, 6 and 0 sizes are stamped with their trade mark—the deer complete in ladies cases, and the deer's head and antlers on gentlemen's cases—and are accompanied by a copy of their certificate, a facsimile of which is given in their advertisements on page 8. The popularity of the "Granger" case is not surprising when we consider its merit. It is of double stock, made in the same method as the company's celebrated, wheat cases the wearing surface being 14k. gold, the inner layer being of a lower grade of gold. This gives the case the appearance that a fine case has, while the layers being of sufficient thickness, it possesses the solidity and resistance of wear of the filled cases. The price of this gold case is almost the same as that of the filled cases. The engraving of these cases are varied and attractive and numerous new styles have just been introduced. A good business is being done in them as in also the well-known "Eagle" and "Wheat" cases.

—The death of Peter B. Simons of San Francisco, Cal., on Nov. 12th, caused regret to a large circle of business men by whom he was respected and admired. Death was caused by Bright's disease, the deceased passing quietly away. Mr. Simons had been identified with the jewelry trade for about 50 years and at his death was head of the house of Peter B. Simons & Son, of San Francisco. In 1840, with his brother George W. Simons deceased, he founded in Philadelphia, Pa., the now widely-known house of Simons, Bro. & Co., their relations being maintained until three years ago when Peter, or Uncle Peter, as he was familiarly known, severed his connection with the firm, and with his son, G. Stuart Simons established the western house. Mr. Simons had dwelt in San Francisco since 1881, and had enjoyed excellent health, attending to business daily, until, a year ago when he dismissed all business cares from his mind and remained about his apartments in the Pacific Hotel, most of the time. He died in the 69th year of his age. The deceased gentleman was one of the pioneer travelers in the jewelry business and is said to have been the original manufacturer in the United States of cases and thimbles. During the war he did active service on the Union side in connection with the Sanitary and Christian Commissioners, and ever pursued the same line of philanthropic work in civil life. He was known throughout the country as a power for good in Y. M. C. A. circles, and had served as president of that association in San Francisco.

—James Schawel & Co., 29 John street, New York, are now importing platinum with which they can supply the trade at reasonable rates.

—Hollinshed Bros., 806 Chestnut street, Philadelphia, are residents of Camden, N. J., and have offered to donate to the Home of the Aged Women of the M. E. Church in that city, all the necessary silver-plated ware required in furnishing the Home.

—C. Cottier & Son, 169 Broadway, New York, have on hand one of the finest assortments of gems and colored stones that can be found anywhere. Many years' experience as importers have established European connections, such as few importing houses enjoy.

—Isaac Goddard of Goddard & Moses, Richmond, Va., was on Nov., 12, granted letters patent on improvements in stem winding and setting watches, that contain several remarkable features. A full description of these improvements with proper diagrams, etc., will be published in the January CIRCULAR.

—H. H. Heinrich, the well-known chronometer maker of 16 John street, received the highest honors at the Paris Exposition for his chronometers. To those in want of a chronometer, we would say Mr. Heinrich will send one on rent, and in the event of a sale being made, will apply the amount paid in rent to the purchase price.

—In the bronze department of Taylor & Brother, 860 Broadway, New York, every variety of figure and combination is displayed—gnomes, cupids, courtiers, savages, maidens, etc. A special feature of the show-rooms is a diversified assortment of fine clocks in Mexican and Californian onyx, Turkish blue marble, porcelain and other attractive material.

—During the first week of the month the Pan-American Congress visited Pittsburgh, Pa., and was accorded the usual banquets, receptions, shows, drives, etc. At a reception at the Monongahela House, the gentlemen of the reception committee were distinguished by pretty bronze badges made by Heeren Bros. & Co., the well-known jewelers of that city.

—The virgin silver novelties which Cattelle & Decker, 20 Maiden Lane, New York, lately introduced, have met with such extraordinary favor, that the manufacturing facilities of the firm are barely able to keep pace with the demand. Under these circumstances it is not to be expected that goods can be sent on memorandum, unless of a very limited extent and for a very short period of time.

—Henry Goll & Co., of 4 & 6 Liberty place, New York, makes a specialty of repairing watch cases, no matter how badly damaged the case may be. A gold case, battered out of shape, was recently brought for repair by the friends of a railroad conductor who had been killed in an accident; but Mr. Goll succeeded in making a very presentable and wearable case of it. Give Mr. Goll a trial and you will be satisfied.

—The second week of last month opened the annual festival at Charleston, S. C. The streets of the city were thronged with thousands of visitors and decorations this year were far more elaborate than heretofore. The jewelry stores like all the other places of business were arrayed in holiday attire. In the Trades Display, S. Thomas Jr. & Bro. and James Allan & Co., had each a float; that of S. Thomas, Jr. & Bro., representing the front of their handsome jewelry store, while the Allan float was an enormous watch bearing on either side the name of the firm.

—M. B. Bryant, of M. B. Bryant & Co., ring makers, 10 Maiden Lane, celebrated the 40th anniversary of his connection with the jewelry business on November 13th. He entered the employ of E. Ira Richards & Co., in the old Rathbun hotel, in 1849, and remained with that firm as their New York agent for ten years. In 1859, he formed a partnership with J. H. Bentley, which continued for twenty-seven years, the relations being dissolved in 1886, and the firm of M. B. Bryant & Co., succeeding to the business. They make a very extensive line of rings in the most desirable patterns, many of which are original with them, and report a steady increase in trade.

—George F. Kunz, with Tiffany & Co., and one of the representatives of the United States government at the Paris Exposition, returned home on Sunday, November 24th, laden with honors present and prospective. He received the decoration of the palm of the Academy, a distinction conferred only upon men of eminence in science or art, and many other marks of favor were shown him by learned societies abroad. His exceedingly valuable work on "Precious Stones in the United States and Canada," will be off the press some time this month. It will be illustrated by a number of beautiful chromo-lithograph plates of noteworthy native gems, which will add greatly to the value and beauty of the work.

—E. R. Stockwell, 19 John street, reports an increasing demand for class rings and pins, which he has made one of his specialties for many years.

—The speed in the Waltham watch factory has run 13 hours a day since Sept. 1.

—The local papers of Elgin, Waltham and other watch towns, during the past month, circulated the following item: "The Tiffany & Co. non-magnetic watch factory will be located at Geneva, Switzerland, where the buildings are already up. American machinery will be used, and, of course, cheap European labor. Tiffany & Co.'s headquarters are in New York city, and they expect to bring their movements into America's markets at a lower rate than home made watches can be sold." The representative of the CIRCULAR, in an interview with Mr. Cook, of Tiffany & Co., learnt that these statements were entirely false, and that the firm has no idea of starting a watch factory in Europe.

—No more artistic line of silverware and novelties can be found than that offered this season by the Derby Silver Company, of Birmingham, Conn. One of the merits of their goods lies in the fact that the metal they use called "M. & B." metal, is a patented alloy, which permits of a much higher and more durable oxidize finish than that commonly employed. Their new designs exhibit a taste and variety that entitle the house to a place among the leaders in this branch of manufacture so far as quality is concerned. They make a specialty of toilet novelties of all kinds, including brushes, mirrors, both hand and triplicate, manicure sets, colognes, etc., etc. A line of oxidized silver clock sets with gilt trimmings, which they have recently put upon the market, is deserving of the highest praise for merits of both design and finish. On another page they illustrate one of their new baskets with openwork border and gold center.

—The office of L. A. Cuppia, at 42 East 14th street, New York, when THE CIRCULAR's representative visited it a few days ago, was the scene of much activity, and coming from the factory was that din of machinery in action, the working of tools, etc., which denoted a healthy state. The firm has prepared, and is keeping replete, for holiday demands, an unusually fine line of goods, entirely new in design. We see, in plain, oxydized or gold-plated silver, cane heads that vie in original and attractive designs, with anything produced this season; a novelty in the shape of a cane head and match box combined, uniquely designed charms, match boxes representing dominoes, bunches of segars, horse shoes, etc., beautiful bonbonnieres and powder boxes, and a host of other small wares such as memorandum books, penholders, paper cutters, envelope openers, etc. A pretty novelty is a bracelet of Roman coins so joined that they are capable of being folded up into a small roll and being dropped into a little cylindrical box, just the width of the coin. The article is patented. Another noticeable feature of Mr. Cuppia's stock is a large assortment of silver necklaces, in balls, ropes, etc.

The secretary of the Jewelers' League has sent to the members a very handsome circular calling attention to the encouraging record of the past year and presenting a few facts for their consideration. The heading is a beautifully engraved design introducing the well-known symbols of the League. The secretary's exhortation reads as follows:

Fellow Members of the League:

As this is the last opportunity for the Executive Committee to address you this year, it is used to bring to your attention the comparatively small number of deaths during the past twelve months, and consequently the cheap insurance you are enjoying.

There are nothing like facts and figures to upset unfounded theories.

The theories of certain persons would, long ago, have brought your League to an end.

The facts are, that insurance in the League has cost, in its 13th year, less than in any of the three previous years; that its reserve fund approaches \$100,000, and that it is in a sound and prosperous condition.

Those who have been members of the League for say ten years, have contributed over half a million dollars to relieve the bereaved and afflicted families of fellow jewelers—in most cases, the amount received being all that the families had to depend upon.

In doing this, the members have also provided insurance of \$5,000 for their own families, at the nominal cost of about \$30 per annum.

This year's decrease of membership has been very slight. There will be no decrease at all, if 50 members will each at once send in the application of a single person.

It will be very strange, if 2700 active members of the League do not secure the above number of jewelers to share in the benefits of the League, and have them initiated before January 1st, 1890.

The members of the Executive Committee challenge the membership at large to prove its confidence in them, by responding promptly to this last request of 1889.

Secure new members from among your acquaintances, and thus avert the necessity of spending money for hired agents.

Yours Respectfully,

GEORGE R. HOWE,

Chairman of the Executive Committee.

WILLIAM L. SEXTON,

Secretary and Treasurer.

Among the Watch and Clock Companies.

—The Waltham Watch factory is making 1,000 electrometers for the Thomson-Houston Electric Co.

—Rumor again has it that an English syndicate wants the Elgin Watch Company, and has offered \$8,000,000 for the plant.

—It is calculated that it must take about a million and a half a year to pay the present force of employees at the Elgin works.

—The Waltham Company employs 2,750 watch and casemakers at Waltham and 705 casemakers in Brooklyn, a total of about 3,500.

—John C. Dueber will build in Canton, Ohio, during the coming year a handsome residence, of Lake Superior brown stone, with hard wood finish throughout, to cost about \$30,000.

—The United States Watch Co. have been for some weeks past running their factory during noons, as well as nights, most of the hands returning to their benches at 12.30 o'clock.

—The E. Howard Watch and Clock Co. are one-half assignees of two recent patents—a clock striking mechanism and a watch movement box, and whole assignee of a watchman's clock station.

—Ex-Manager Bitner, of the Keystone Standard Watch Co., Lancaster, Pa., it is said intends to sell his real estate in that city and move to some western city this month, where he will start a watch factory.

—The Elgin Watch Company on Nov. 15 placed on the market a new grade—B. W. Raymond nickel, open face, pendant setting watch, corresponding in price with their hunting nickel B. W. Raymond movement.

—The Secretary of State of Illinois has licensed the Non-Magnetic Watch Co. at Peoria for the manufacture of watch movements, etc., capital stock, \$50,000. The incorporators are W. H. Hammond, H. H. Hopkins and Carrie Geathard.

—The Chicago Non-Magnetic Watch Company, which wanted to locate at Lincoln, Ill., as stated in another paragraph, is said to be considered not worth securing by the citizens. But the city will, however, never rest satisfied until it gather in a watch works.

—The 6 size Hampden movements now being manufactured in four grades are, to quote numerous jewelers, "the watch." The Hampden ladies' movements are undoubtedly among the finest modeled and most perfectly finished watches on the market.

—The new nickel movement put on the market by the Trenton Watch Co. is as neat in appearance as it is low in price. This movement, with a nickel silver case, makes a very complete watch, as will be seen by referring to their new advertisement on page 108.

—Superintendent Hunter and J. M. Cutter, of the Elgin Co.'s Chicago office, visited Aurora on the 20th and took an optical survey of the watch works there. It is said that their mission was to see if any of the machinery there could be used in the Elgin factory.

—The Elgin watch factory rule that employees not at their benches when the bell stops ringing, 7.05 o'clock, are docked 15 minutes, and that those failing to get in before the doors are closed are obliged to lose one-quarter of the day (1.05 o'clock) before they can gain entrance, will probably be enforced at the Rockford watch factory.

—Regarding the rumor that Chas. D. Rood, of the Hampden Watch Company, will start a watch factory in the watch factory building at Springfield, Mass., about February 1, Mr. Rood says: "I have not formed any plans for starting a watch factory at Springfield, Mass."

—John C. Dueber and Charles D. Rood, of the Dueber and Hampden factories, visited Aurora, Ill., on Nov. 18, with a view to purchasing the Aurora plant, if it could be bought at a reasonable figure, and moving it to Canton, Ohio. Besides this project, other improvements in the Canton works are to be made.

—Thomas M. Avery, of the Elgin National Watch Company, and Royal E. Robbins, of the American Waltham Watch Company, brought suit in the United States Circuit Court on Oct. 26 against the Illinois Watch Company and its officers. The bill is for alleged infringement of a patent for improvements in stem winding watches.

—The work of making tools and machinery at the new Otay watch factory at Otay, Cal., has been in part the employment of experts during the past few months, until now they have several fine machines ready for operation, prominent among which is a double parallel grinder which works automatically. This machine was designed by P. H. Wheeler, superintendent of the factory.

—Paillard Non-Magnetic Watches, in ladies' small sizes, beautifully decorated in enamel designs interspersed with diamonds and precious stones, are receiving the attention of the fine retail trade, and add much to the attractions of their stock.

—The Dueber Heights industry has found it necessary to operate many of its departments at night since the fall season's work began. There has been a marvelous development in the manufacture of watch movements alone, in the last six months. The production has increased not only 100 per cent., but the number of watch movements made per day, or week, or month, now is estimated to be more than double what it was a half year ago.

—The town has been agitated to-day over the report that a company of men of Chicago propose to locate a watch factory here. The proposition comes in the shape of a letter in which the gentlemen state they will invest \$50,000 and employ fifty men at the start, to be increased to 500 within a few years from the time operations are begun. The part exacted from Lincoln is two and a half acres of land and \$15,000.—Lincoln (Ill.) *Courier*. A committee of citizens of Lincoln who went to Chicago to examine into the conditions of the company, have reported adversely to the scheme.

—On Nov. 1 A. C. Smith became the general selling and sole agent for the entire product of the Non-Magnetic Watch Co. of America, thereby assuming the commercial business of that company in his own name. All outstanding accounts to that date were closed by the Non-Magnetic Watch Co. and new ones opened by A. C. Smith. No interruption of existing contracts or business relations under the new name will occur. Prices will be vigorously maintained, and the same progressive policy pursued that has characterized the company from the start.

—W. W. Hastings, superintendent of the New York Standard Watch Company's factory, recently patented a machine that will, it is said, radically change the processes of clockmaking. By a perfectly automatic process, requiring no other attention than to be set to the required gauge and fed, the machine will cut the pieces of metal to their proper size and then cut the teeth, dropping the wheels, finished and ready for the clock, to the work bench below. The machine is but about three feet long and is compactly built, in a strong and durable manner. Mr. Hastings was formerly connected with the Waltham Watch Company, and has just finished one of the machines for them. It can be seen working at the Standard factory.

—Messrs. Rood and Dueber, of the Hampden and Dueber factories, have the matter of purchasing the Aurora works under consideration, and Assignee Evans has informed them that they must be heard from very soon. In case nothing satisfactory develops the entire plant will be sold under the hammer. Another party who seems to be in earnest about purchasing the factory is a Minneapolis capitalist, who has visited Aurora three times. It is said that he would probably pay more than anyone else. The employees of the factory are rapidly scattering, more than seventy-five of them having gone to other places to seek employment. The new factory at Otay, Cal., is attracting some of them, while others have gone to Elgin, Springfield, Rockford, Canton and other places.

—At the Elgin factory work is being pushed in all the departments as fast as possible to keep pace with the constantly increasing demand for movements, the call for the higher grades being the greatest. Improvements are being made and facilities increased. A portion of the upper main corridor has been fitted up for the staff pivoting job. Some of the departments not having room enough to comfortably accommodate the required number of operatives, other hallways are being used by bench workers on both the upper and lower floors. When the company built their last addition of department rooms and the various departments were installed, there seemed to be an overplus of room that threatened to be unused for years to come.

—The Hampden building in operation only fifteen months has increased from 750 employees at Springfield to about 1,900 in Canton. The capacity of this building, with all departments full as planned, is something over 2,000. Yet, as the business develops in different grades of work, it is found that some departments are already too small for the growth of the work. There have from time to time been minor additions, but it is now intended that an addition 150 feet long and three stories in height will be built in the spring, being an extension of the south wing of the Hampden factory towards South street, to give additional room for the damaskeening, screw, plate and dial departments. This extension would make quite a good sized factory in itself, and will add greatly to the already imposing structures on Dueber heights.

—The Rockford factory is now illumined by electricity.

—The Crescent Watch Case Co. have just placed in the market a line of Crescent Regent cases with box joint, 14-k. gold filled, 18 size, and in new and attractive designs.

—W. F. Gardner, of the Seth Thomas Clock Co., whose system of standard time in the Naval Observatory Time Service exhibit at the Paris Exposition was considered of such excellence as to merit a grand prize, secured also individually a silver medal. Mr. Gardner will shortly return to America.

—The Prize Watches (eight in number), together with their Observatory Bulletins and numerous medals, have been received by the Non-Magnetic Watch Co. These watches rank among the highest class of horology, and as each contains Paillard's non-magnetic balance and hairspring, it is conclusively proved that watches with these balances and hair springs are capable of attaining the highest standard.

—The Bombay (India) correspondent of the *American Mail and Export Journal*, writes as follows: "There has of late been a great impetus given to the trade in watches, the Waterbury Watch Company having by its effective system of advertising called the attention of the masses to its cheap and serviceable importations, and now almost every clerk in this city possesses what only a few years ago was deemed a luxury for the comparatively rich only, and the demand will doubtless spread; indeed, it is spreading rapidly to the districts."

—The American Waltham Watch Company are enjoying a steadily growing demand for their non-magnetic watches. Regarding magnetism in watches, the company makes the following assertions:

"All watches not specially protected from magnetism are more or less magnetic, and consequently must be more or less irregular time-keepers. No perfection of construction and adjustment secures a watch against the mischievous effects of this universal natural influence. In these days of the common use of generators of electricity, watches are more than ever liable to become polarized, even though they be not specially exposed to the immediate magnetic fields of dynamos, motors, or other heavy magnets. Watches may acquire a degree of polarization through touching or being handled with magnetized tools, to say nothing of the effects of the imperceptible and comparatively unknown forces of natural polar attraction. Undoubtedly many of the puzzling aberrations of even the finest watches are due to these subtle influences."

Speaking of their magnetic watches, the company further says:

"The only defence which is radical and sure, is that which has been invented and applied by this company. It consists, in brief, of making the entire escapement, including balance and hairspring of metals which are by nature wholly insensible to magnetism. This safeguard is inexpensive and may now be had in Waltham watches of all grades. Any Waltham watch already in use may, at trifling cost, be refitted with it."

The New York Jewelers' Association.

The business of the several meetings held during the past month, turned principally upon matters pertaining to the Annual Dinner, which was celebrated on the night of Nov. 21st, at Delmonico's well-known saloon.

Three new firms took advantage of the temporarily revised by-laws, and were admitted to membership. They were Sexton Bros. & Washburn, E. E. Kipling and Hayden W. Wheeler & Co., all of New York.

The amounts collected by the Association up to Nov. 27th, towards the New York World's Fair Guaranty Fund of \$5,000,000, are given below, and foot up a flattering total:

Robbins & Appleton	\$10,000	Chas. Magnus	500
Carter, Sloan & Co.	5,000	C. G. Alford & Co.	500
Randel, Baremore & Billings	5,000	Geo. O. Street & Sons	300
Dennison Mfg. Co.	5,000	E. E. Kipling	300
Alfred H. Smith & Co.	2,000	Henry C. Haskell	250
Meriden Britannia Co.	2,000	Geo. M. Bacon	200
Hayden W. Wheeler & Co.	1,000	Bernard Karsch	100
Peterson & Royce	1,000	C. M. Koloseus	100
Alling & Co.	1,000	Chas. Schumacher	100
Wm. S. Hedges & Co.	1,000	B. F. Moore & Son	100
J. B. Bowden & Co.	1,000	P. B. Levy	100
H. B. Dominick	1,000	Chas. A. Shumacher	100
Krementz & Co.	1,000	F. C. Gleason	50
Benedict Bros	1,000	C. K. Colby	50
Ludeke & Co.	1,000	C. Sidney Smith	50
Brooklyn Watch Case Co.	1,000	Wm. T. Gregg	25
Geo. W. Shiebler	1,000	W. Downey	25
Saifer & Douglass	500	R. & L. Friedlander	25
J. T. Scott & Co.	500	Blancard & Co.	25
Smith & Knapp	500	M. Goodfriend	10
Henry Ginnel & Co.	500		
N. H. White	500	Total	\$45,410

Horological School Notes.

Prof. Fenner, of the Chicago Horological Institute, has invented an electric motor which is a great improvement over anything now in the market. Heretofore all motors manufactured have been of dynamo form. Generating a current if run in an opposite direction and making it necessary to use double the current to get the desired power. The advantage claimed for this motor is that it is not a generator, running in either direction, and hence double the power can be obtained from it than could be from one of the old pattern. This motor, while empty, makes 3,000 revolutions per minute, and develops one-half horse power with 113 volts. The entire motor is but 8 inches wide, 12 inches high, and 12 inches long.

The directors of the Chicago Horological Institute are so certain in their own mind that their city is to be the site of the World's Fair that President Frink of that Institution states that he has already formulated a plan which will result in their making a display of one hundred model escapements and movements, the work of students in the school, besides many sketches and drawings.

Considerable interest is being manifested in a model of a Hampden watch escapement which was recently constructed by students in the school of J. L. Hutchinson, La Porte, Ind. The Hampden Company itself spoke highly in praise of the workmanship, as also the Waterbury Watch Company and superintendent Byam, of the Trenton Watch Co.

Says the *Waltham Free Press*:

"During twenty or more years which D. D. Palmer's horological school has been established in this city, Mr. Palmer has advertised but little, but recently having done so in the *Jewelers' Circular*, he is receiving on an average about 20 applications a day, many more than he can possibly accommodate."

Mr. Palmer met with a painful accident on the Fitchburg railroad, which deprived him of the use of one arm, and delayed the completion of a new tool he is inventing for watchmakers.

One of the features taught students at Hutchinson's school, La Porte, Ind., is the changing or remodeling of watch movements. They select a fair English movement, remove the old mainspring barrel and fusee and chain and by very careful measurements construct a new barrel with teeth like the American mainspring barrel. A new barrel arbor is then constructed and proper click and ratchet work arranged.

The opening of the new building of the Parsons Horological Institute at La Porte, Ind., occurred on November 18th. Attractive cards of invitation to the opening exercises and house warming had been issued, and the affair was quite an event. Speeches were made by John C. Dueber, C. J. Olin, Theo. Gribi, J. H. Purdy, Mortimer Nye, and others. If the old adage about people who live in glass houses is true, the Parsons school will have to be very circumspect, for there is no lack of window light anywhere in the whole building. The new building is an imposing structure of two stories and basement, surmounted by a clock tower 80 feet high. This tower is to carry a clock manufactured in the school by the students. Eight departments are included in the institution, as follows: Room No. 1, the first steps of watch work, jewelry work and tool factory; No. 2, pinion work, lathe work, jewelery and cutting; No. 3, finishing, springing, timing, adjusting, demagnetizing and repairing; No. 4, gilding. One room in the basement is used as a reading room for the students, and another as a factory for the larger tools needed in the school. The institution is supplied with the latest improvements in machinery, and furnishes its own steam power from an engine in the basement. The opening exercises included addresses by C. J. Olin, of Piqua, O., Theo. Gribi, of Chicago, J. H. Purdy, of Chicago, John C. Dueber, of Canton, O., and Mortimer F. Nye, of New Bedford, Mass.

—There is something remarkable about the close running of the two astronomical clocks at the Waltham factory. They have been visited by astronomers from Greenwich, England, Australia, Canada, and in fact all the prominent astronomers of the world, so great has their reputation become. Professor Rogers, the well-known astronomer at Harvard College, says that they are among the finest running clocks on the face of the earth, and he is seconded in this statement by other prominent astronomers of this country and Europe. The clocks were built at the factory.

—The reader by referring to the card of Winship & Wiger on the opposite page, will be surprised by the variety of their business. Besides being manufacturing jewelers and diamond setters, the advertisers do repairing, engraving, gold and silver plating for the trade, and make every kind of jewelry to order. Their address is 78 State street, Chicago, Ills.

TABLE OF CONTENTS.

Around Boston.....	31	Foreign Gossip.....	47	Northwest, The.....	34	Recent Patents.....	75
Barometer Compensation on the Pendulum,	71	Gossip of the Month.....	21	Obituary.....	29	Screw Gauge.....	67
Breguets' Escapement with Natural Impulses.....	68	Jerusalem to be the Initial Meridian.....	68	Our Round Table.....	41	Trade Gossip.....	85
Carving in Ivory.....	51	Jewelers' League, The.....	76	Paris Gossip.....	48	Workshop Notes.....	64
Chicago Briefs.....	30	Jewelers' Security Alliance.....	76-37	Parisian Novelties.....	36	World of Invention, The. Improved Stem	
Communications.....	37	Jewelers' and Tradesmen's Company, The.....	34	Pliers for Straightening Bent Pivots.....	67	Winding and Stem Setting Watches by	
"Double Event" Cup.....	26	Mechanical Ocular Defects.....	59	Problems in the Detached Lever Escapement.....	63	IsaacGoddard. Improved Watch Bow.	
Fashions in Jewelry.....	52	Neglected Problems.....	38	Proceedings of the Watchmakers' and Jew-		New Pendulum adjusted to Tempera-	
" Art Glass and Ceramics.....	56	New York Jewelers' Association.....	47	elers' Union.....	41	New Tools for Watchmakers.	
Foreign Matters.....	82	New York Jewelers' Board of Trade.....	47	Providence Notes.....	33	Receiptable Watch Case. The Spencer	
						Opera Glass Holder.....	79

INDEX TO ADVERTISERS.

Aby, Chas. Leo.....	73	Essex Watch Case Co.....	69	Lorsch, Albert, & Co.....	Outside back cover	Marcy, F. I. & Co.....	50
Alkin, Lambert & Co.....	43	Falkenau, Oppenheimer & Co., Outside bk cov.		Mathey Bros., Mathez & Co.....	12	Shearer, W. H., & Co.....	74
Alvin Mfg Co.....	39	Floyd, Pratt & Rounds.....	57	McCall & Newman.....	79	Shiebler, Geo. W.....	74
American Horological Institute.....	35	Folkart, Wm.....	17	Meriden Britannia Co.....	3	Smith & Knapp.....	70
American Waltham Watch Co.....	46	Foster & Bailey.....	78	Merritt, S. F.....	19	Smith, Alfred H., & Co.....	23
American Watch Tool Co.....	39-35	Fox, M. & Co.....	62	Miller Bros.....	54	Smith B. & W. B.....	outside back cover
Arnstein Bros & Co.....	18	French, J. H.....	69	Moore & Horton.....	70	Smith, H. M. & Co.....	69
Atkinson Bros.....	58	Friedlander, R. & L.....	6	Morse, Mitchell & Williams.....	13	Special Notices.....	93
Atwater, William H.....	1	Geneva Optical Co.....	8	Myers, S. F. & Co.....	Inside Back Cover	Spencer Optical Mfg Co.....	7
Baird, Henry Carey & Co.....	77	Goldsmith Bros.....	2	New Century Electric Co.....	24	Stark, John.....	15
Barrows, H. F. & Co.....	Outside Back Cover	Goll & Co., Henry.....	16	N. Y. Watch Case Spring Co.....	93	Sterling (The) Company.....	4
Bartholomew & Peckham.....	117	Gorham Mfg. Co.....	20	Newman, Louis, Jr.....	17	Stockwell, E. R.....	70
Beatty, W. A. & Co.....	14	Haldimann, E. A.....	18	Nissen, Ludwig, & Co.....	54	Sussfeld, Lorsch & Co.....	62
Beguellin, Tell A.....	92	Hancock, Becker & Co.....	57	Non-Magnetic Watch Co.....	32	Talntor & M:Alpine.....	73
Birch, John S., & Co.....	92	Hartford Silver Plate Co.....	8	Noterman, Jos. & Co.....	66	Tannenbaum, L & Co.....	74
Blancard & Co.....	73	Haskell, H. C.....	77	Oppenheimer Bros. & Veith.....	66	Taylor & Bro.....	74
Bookhout Bros.....	17	Hausburg, O. E.....	17	Oppenheimer, Henry E. & Co.....	49	Ternendt, F.....	17
Boston Clock Co.....	1	Hearn & Braltsch.....	14	Owen, G. & S., & Co.....	74	Todd, Ed. & Co.....	Outside back cover.
Bowden, J. B., & Co.....	43	Hedges, A. J., & Co.....	54	Pairpoint Mfg Co.....	6	Towle Mfg Co.....	57
Brooklyn Watch Case Co.....	31	Hedges, Wm. S. & Co.....	65	Pamphilon, H. W.....	93	Trenton Watch Co.....	88
Bryant, M. B. & Co.....	58	Howard, S. P.....	Outside back cover	Peterson & Royce.....	50	Troemner, Henry.....	17
Bullock, O. W. & Co.....	19	Hunt & Fuller.....	18	Pforzheimer, Keller & Co.....	39	Valuable Instruction Books.....	98
Bynner, T. B.....	17	Hutchison & Huestis.....	27	Pinnell, May & Co.....	62	Wade, Davis & Co.....	46
Carter, Sloan & Co.....	53	Hyde's Sons John E.....	66	Plainville Stock Co.....	58	Waltham School of Horology.....	73
Cattelle & Decker.....	50	Imhauser, E.....	17	Platt, Chas. S.....	Outside back cover	Waltham Watch Tool Mfg. Co.....	16
Chalmers-Spence Co.....	69	Jacot & Son.....	50	Prindle & Russell.....	77	Wallace, R., Sons Mfg Co.....	53
Champanois & Co.....	73	Jacques, Charles.....	28	Putnam's Sons, G. P.....	39	Want, Edwin.....	18
Chicago Horological Institute.....	77	Kahn, L. & M. & Co.....	14	Racine Jewelry Mfg. Co.....	17	Washburn & Moen Mfg. Co.....	17
Clark, A. N.....	66	Keller, L. H. & Co.....	92	Randel, Baremore & Billings.....	84	Washburne, E. G. & Co.....	18
Cooke's, B. J. Sons.....	66	Kendrick & Davis.....	69	Riley, John A.....	61	Watchmaker, Jeweler and Silversmith.....	92
Cottler, C. & Son.....	17	Kent & Stanley.....	61 & 19	Robert, J. Eugene, & Co.....	45	Waterbury Clock Co.....	1
Cottle, S. Co.....	19	Ketcham & McDougall.....	6	Rogers & Bro.....	9	Waterbury Watch Co.....	91
Crescent Watch Case Co.....	46	Kluber, S. & Co.....	14	Rogers, Smith & Co.....	12	Weil, Maurice.....	18
Cross & Beguettin.....	15	Koch & Dreyfus.....	83	"Royal" Initial Ring.....	24	Welch, E. N. Mfg. Co.....	1
Crossin & Tucker.....	49	Kohlbusch, Charles.....	17	Russell, Irving L.....	77	Wheeler, Hayden W. & Co.....	45
Crossman, Chas. S. & Co.....	43	Kremetz & Co.....	91	Sauter, L. & Co.....	62	Wiggers & Froelick.....	Inside Back Cover
Cummings, Josiah & Son.....	98	Lapierre, Frank H.....	87	Schleicher, Schumm & Co.....	70	Wilkinson, C. B.....	17
Didisheim, Hipp.....	62	Laurecot, J. B.....	Inside Back Cover	Scheldig, John & Co.....	18	Woglom, Gilbert T.....	70
Dorflinger, C. & Sons.....	24	Lawson & Van Winkle.....	58	Scott, J. T. & Co.....	28	Wood & Hughes.....	74
Dreyfus, Henry, & Co.....	11	Lelong, L. & Bro.....	outside back cover	Seth Thomas Clock Co.,.....	Inside front covr	Wood, J. R., & Son.....	17
Dueber Watch Case Mfg. Co.....	10	Logan, A. J.....	16	Sexton Bros. & Washburn.....	77	Zineman, M. & Bro.....	62

KETCHAM & McDOUGALL,

MANUFACTURERS,

GOLD AND SILVER THIMBLES,

The Automatic Eye-Glass Holder, Gold Collar Buttons,

198 BROADWAY, NEW YORK.

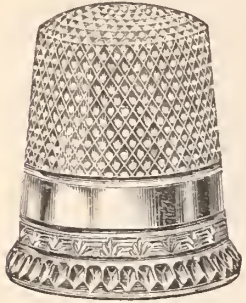

103 (New).
Same price as plain thimble



105 (New).
Same price as plain thimble

We offer to the Trade our **GOLD COLLAR BUTTON** (Patented July 12th, 1887). It is very strong, made **without Solder**, and finished **Spring Temper**. It has Radial Ribs both in head and back, where strength is most needed.

SAMPLES AND PRICE LIST FURNISHED ON APPLICATION.

PAIRPOINT MANUFACTURING CO.,

NEW BEDFORD, MASS.,

FINE GOLD AND SILVER PLATED WARE.



No. 2628.--Plain Gold Lined, \$4.25.



No. 3550.--Lunch Set.

The Largest Line of Novelties of Wedding and Holiday Presents on the market.

New Lines
IN
Inkstands,
Button
Hooks,
Paper
Knives,
Letter
Openers,
Salad
Bowls,
Bon-Bon
Trays,
Etc., Etc.

CATALOGUES ON APPLICATION.

20 Maiden Lane, NEW YORK. 90 & 92 Wabash Ave., CHICAGO, ILL. 220 Sutter St., SAN FRANCISCO, CAL. Sydney, AUSTRALIA.

R. & L. FRIEDLANDER,

65 & 67 Nassau Street,

NEW YORK CITY.

American and Swiss Watches,

Gold and Plated Jewelry, Tools, Materials,
and Optical Goods.

SEND FOR OUR LATEST CATALOGUES. SELECTION PACKAGES SENT TO RESPONSIBLE DEALERS.



Readers, Please Mention **THE JEWELERS' CIRCULAR** When Writing or Buying.



VOLUME XX.

NEW YORK, JANUARY, 1890.

No. 12.

THE JEWELERS' CIRCULAR AND HOROLOGICAL REVIEW.

OFFICIAL REPRESENTATIVE OF THE JEWELERS' LEAGUE, THE NEW YORK JEWELERS' BOARD OF TRADE, AND THE JEWELERS' SECURITY ALLIANCE.

It is also the Recognized Exponent of Trade Interests.

A MONTHLY JOURNAL DEVOTED TO THE INTERESTS OF WATCHMAKERS JEWELERS, SILVERSMITHS, ELECTRO-PLATE MANUFACTURERS, AND THOSE ENGAGED IN THE KINDRED BRANCHES OF ART INDUSTRY.

SUBSCRIPTION.—To all parts of the United States and Canada, **\$2.00 per Annum**, Postage Paid. To all Foreign Countries, **\$3.00 per Annum**, Prepaid.

All communications should be addressed to

THE JEWELERS' CIRCULAR PUBLISHING CO.,
189 BROADWAY, NEW YORK.

Advertising rates made known on application.



A full Index to Advertisements and a Table of Contents will be found on Page 5 of this issue.

Next month we attain our majority. Volume XXI. begins with the February number, and we shall celebrate with a Gala Number, the finest we have ever issued. Subscribe now and get it.

**

**

**

THE year 1889 rounds up with a fairly satisfactory showing for the jewelry trade. With the exception of the unprecedented advance in the price of diamonds and the signal success of our silversmiths at the Paris Exposition, little has occurred to make the year memorable in the trade annals. These two facts, however, are of more than passing moment, but the rise in the price of diamonds has been maintained, and the prospects even point to higher prices before the limit is reached. The syndicate is in control, and that limit will doubtless be a point not too high to cut off the demand. In regard to the laurels won at the Exposition it may be said most unequivocally, that they were richly deserved, and that the fame of American jewelers' and silversmiths' is now thoroughly established in the art centres of the world. As a result of this we may expect to see a better demand for our art metal work from the aristocratic purchasers of Europe. Those who have followed our quotations from the Treasury reports from month to month cannot fail to have

noticed a constant increase in exports of jewelry, and a slight improvement in other lines, such as clocks and watches. This is sufficient to show that our manufacturers are seeking wider markets for their goods, and that even under the present discouraging tariff schedule it is possible to build up quite an important export trade in such articles of manufacture. With the prospect of a speedy reform in the tariff, that shall be more favorable to our Southern neighbors, we may look for a steady increase in these items of export during the coming year. They have become American staples of manufacture, and are so recognized in the world's markets to-day. Failures have not been excessive, nor has anything else, save the inclement weather of the holiday season, occurred to injuriously affect the trade. While not a booming year, 1889 must be relegated to the historians with grateful recollections of fair prosperity. During 1890 preparations for the World's Fair of 1892 will be in order, and the effect of this gigantic enterprise cannot but be the quickening of all business, especially the jewelry and allied industries. We bid 1889 adieu, with brightest hopes for its successor in the calendar.

**

**

**

OUR London correspondent gives us some interesting information about new schools of design, which the Birmingham jewelers are establishing for the education of artisans in all branches of the trade. Apprentices will be expected to attend these night schools until they are 19 years of age, and possibly for a longer period. English jewelers have been reputed deficient in taste and originality as compared with French craftsmen or our own, but it is only of late years that these artistic defects have been admitted and a remedy sought for. A conscientious study of the best foreign models has opened the eyes of the English jeweler and silversmith to the want of fancy and invention that characterizes their handiwork, however meritorious it may be from the standpoint of solidity and usefulness. Defects that are seen are speedily remedied, and in this concerted action on the part of the English jewelry trade to provide the workmen of the future with the training that shall make them artisans, we have the promise of a new era of progressive effort in that country. It is rather discreditable to us as a nation, and also as a trade, that a country certainly not our superior in artistic appreciation, should show so much greater interest in the matter of trade schools than we do. Our well-earned superiority in metal work to-day will be soon lost if we do not continue to cultivate the aesthetic side of the business even more zealously than in the past. For the triumphs already won we may congratulate ourselves with a good conscience, knowing that they are the result of conscientious effort and a truly cosmopolitan taste. But we cannot afford to rest on our laurels. Other nations are on the alert to wrest the prizes from our victorious hands. Our people are becoming more exacting in their demands every year. The public being more critical, the purveyor must be more ambitious if he is to keep pace with its

demands. That the trade is beginning to realize the necessity for such technical education as is afforded by art schools we have had some proof in the past few years, but the interest manifested is too lethargic to indicate any very deep conviction of our needs. We must have fully trained American artist artisans to develop the ideas that are inherent in us as a people in their ripeness and perfection. To accomplish this our best native talent must be utilized, talent that is now wasted in uncongenial and profitless pursuits. The art school will prove the desired intermediary between the trade and the young designer. We cannot have too many of them, nor that too soon.

* * * * *

Of special interest in this issue: "Neglected Problems," by Excelsior; "Carving in Ivory," "The World of Invention," "Our Round Table," and "The Barometer Compensation on the Pendulum, by C. Beuchtel.

* * * * *

FROM all reliable sources of information a wonderful improvement has taken place in British commerce during the past two years. This improvement has made itself felt in all lines of manufacture, including the cutlery, silver plate and jewelry industries. Prices are going up all around, and the workingman is coming in for a share of the benefit. So marked is the change that, our esteemed contemporary, the *London Watchmaker, Jeweler and Silver-smith*, puts in a word of caution for its readers. After congratulating its readers on the changed aspect of things it continues: "For all that we have not lost our heads as in the inflated times of 1871, when colliers got drunk on champagne, and the British workingman generally thought that he was indispensable. That, however, is the danger which lurks ahead, and is only to be avoided by the exercise of moderation all around." It might be well for our manufacturers to ponder on the reasons which have led to this increasing activity on the other side of the water.

* * * * *

THE report of the Secretary of the Treasury on imports and exports for the months of October, 1889, shows a gratifying increase in exports, especially of jewelry, clocks and watches. The following items are selected as of interest to the trade: Imports of rough and glaziers diamonds, 1888, \$19,983; 1889, \$40,374; imports of clocks and parts thereof, 1888, \$65,600; 1889, \$75,865; imports of watches and materials, 1888, \$171,430; 1889, \$150,758; imports of jewelry, 1888, \$99,774; 1889, \$114,677; imports of precious and imitation stones, 1888, \$721,241; 1889, \$1,349,095. Exports of clocks and parts thereof, 1888, \$98,378; 1889, \$106,968; exports of watches and materials, 1888, \$7,368; 1889, \$92,393; exports of jewelry, 1888, \$39,912; 1889, \$51,629; exports of plated ware, 1888, \$53,570; 1889, \$51,003. The steady increase that has been noted for some months in the exports of jewelry, clocks and watches is a most healthful sign, and indicates that our manufacturers are beginning to make their weight felt in the world's markets. We have been altogether too diffident of our abilities, and have not known our strength. American goods of all kinds need but to be known to be wanted everywhere, and THE CIRCULAR hails this new spirit of commercial conquest with the deepest satisfaction.

* * * * *

Parisian Novelties.—Some of the latest designs in jewelry.—page 36. "A Happy New Year to You."

* * * * *

FOR some time past the Adams' Express Co. has made the effort to compel the valuation of all jewelry packages. Losses in transit have been quite frequent, and when a package was traced up by the detectives of the Safety Fund Society, and the theft laid at the door of some employee of the Adams' Co., that company refused in a number of instances to deliver up the package unless

the owner would pay the expenses incurred in finding it, tendering in lieu thereof \$50, which they claim is the limit of their liability on unvalued packages. This has been a bone of contention between the Adams Express Co. and the Safety Fund Society for some years, and at least one law suit, *Heller & Bardel vs. Adams Express Co.* has grown out of the difficulty. So many complaints came to the ears of the officers of the Safety Fund Society during the past season that the matter was given serious consideration, and the following circular sent out to the members:

To Members of the Jewelers' Safety Fund Society:

It has been found in the experience of the society that a very large percentage of claims for loss in Class B has been presented for packages containing diamonds and other precious stones shipped by the Adams Express Company, and that this express company has attempted to impose upon the shipper the expense incurred in tracing such packages. Members have been informed by officers of this express company that packages without valuation are not cared for by them with the same caution that is given to packages on which a value is marked. For the purpose of equalizing the risk to be borne by members engaged in the different lines of trade the executive committee has passed the following:

Resolved, That members are requested, when shipping by any express company, diamonds or other precious stones, mounted or unmounted, to pack the same in a box which shall measure not less than 5x4x2½ inches, and value the package at not less than \$100, except where the actual value does not amount to that sum, and to see that the package is properly sealed and delivered to the express company at its office. By order of Executive Committee.

HENRY HAYES, President.

IRA GODDARD, Secretary.

The Adams Express Co. are quite reticent about the matter and do not show the sweetest spirit when questioned about it. But it seems likely that the new rule will go far toward removing the cause of this long-standing trouble.

* * * * *

WE present to our readers in this issue a page of selected Parisian novelties in jewelry which will doubtless be found of interest by both retailers and manufacturers. These designs are selected for their originality and typical excellence, and will suffice to show the prevailing modes in jewelry in the world's fashion centre. We shall from this time on frequently embrace the opportunity to lay before our readers a few of the most attractive novelties as they appear in the Parisian market.

* * * * *

Begin the New Year right by subscribing to THE JEWELER'S CIRCULAR, the oldest and best trade paper published in the interests of the watchmaker and retail jeweler.

* * * * *

AS ANNOUNCED in THE CIRCULAR last month a considerable advance in wages has been gained by the Swiss watchmakers this fall. Official notice of this fact was sent to the Swiss importers of this city recently in the following circular:

La Chaux-de-Fonds, November 11

To Dealers in Swiss Watches:

DEAR SIR:—We beg to acquaint you with the fact that a considerable increase in the cost of watch manufacturing has taken place during the year.

Of late years prices have fallen to such an extent that neither makers nor workmen could earn a decent living. This state of affairs was mostly due to the stagnation of business which has so long prevailed in the watch trade.

Since the beginning of the present year, however, business has returned to its normal state, and the production of watches is now scarcely sufficient to meet the numerous orders coming in, a fact which the manufacturers are naturally glad to witness.

These two reasons combined (*i. e.* the unremunerative prices and the increased demand) have caused a well-justified advance in the prices paid for rough movements and workmanship, thus altering considerably the cost of production.

We have, therefore, thought it advisable to inform you of these circumstances in order to enable you to take such measures as you may think proper for the purpose of raising the actual prices of watches largely if possible.

This general advance is extending over the whole Swiss watchmaking industry. It imposes itself as an absolute necessity, and we have no doubt it will be accepted by all those interested in the trade considering the serious reasons explained, and the better state of business in most countries where watches are exported to.

Hoping that you will give your kind attention to the foregoing, we remain, dear sir,

Yours most obediently,

For the Société des Fabricants d'Horlogerie de La Chaux-de-Fonds,
THE COMMITTEE.

In consequence of this it is expected that prices will rule higher during 1890.

Obituary.

GEORGE W. BROWN.

On December 18 there died in New York City after a brief illness another pioneer of the American clock industry—George Whitefield Brown, general manager of the Bristol Brass and Clock Co., of Bristol, Conn. He was born in Bolton, Conn., in June, 1830, and at the age of 15 years apprenticed himself to J. C. Brown & Co., clockmakers, of Forestville, Conn., where he soon began to display his mechanical and business talents. In 1854 he associated himself with Chauncey Goodrich, and they began the manufacture of clock movements in Forestville, Conn., taking the small shop now owned by Thomas Ashworth. Their business increasing with great strides, they added the manufacture of mechanical toys in 1857, at which time the firm name was changed to George W. Brown & Co., and, purchasing a larger factory, they added the production of tin toys and other novelties to their business. Under Mr. Brown's able management the business increased to such proportions that more room was required and several large additions were built to the main factory. A fire visited the concern in 1861 and totally destroyed the plant, which was only partially insured. Undaunted by this great loss Mr. Brown went energetically to work, and soon had a new factory more commodious than the old one in good running order. In 1862 he added the manufacture of lamp burners and trimmings to his numerous specialties. Owing to the remarkable increase of the business more capital was needed, and in 1868 he sold the entire lamp burner business to the Bristol Brass and Clock Co., one of the several large concerns controlled by the late E. N. Welch, entering into a contract with that company to manage this branch of the company's business, which position he retained until his death, the business growing to large proportions under his management.

The funeral occurred with Masonic rites at his old home at Forestville, Conn., on the 21st, and was attended by a large number of his friends and employees. Mr. Brown leaves a widow and four children, three daughters and one son, George S. Brown, who has been engaged in business with his father for about fifteen years. The deceased was a man of warm heart, the strictest business integrity and the highest ability, and his advice was frequently sought by his associates and freely given. A man's character can be judged by the regard manifested by his employees who have been associated with him daily for years, and judged by this exacting standard he was a man of the most endearing qualities.

STEPHEN T. FRAPRIE.

When it became known in the trade on the morning of December 17 that Stephen T. Fraprie, of Wood & Hughes, 16 John street, had passed away the previous night, expressions of sorrow were heard on all sides, especially among the older members, who had known the departed for upwards of half a century. He had been in his customary robust health until within ten days of his decease, when a severe cold obliged him to discontinue his daily visits to his place of business, and he remained quietly at his home, 30 Second street, New York.

A history of the life of Mr. Fraprie is essentially a history of the firm of which he was a member, the widely-known silverware manufacturers, Wood & Hughes, 16 John street, New York, for his whole career in business, extending over a period of fifty-seven years, was passed with that house. He was undoubtedly the oldest if not the most widely-known silversmith in the country, his name being familiar to thousands of people.

He first saw the light on September 12, 1820, in Cambridge, Mass., His father was a French sea captain who had exercised considerable influence during the French Revolution. His mother was of American birth. When he was nine years of age the Fraprie family moved to New York, then hardly more than a straggling town. In 1832

he became an apprentice in the silversmithing factory at 116 Fulton street, of Gale, Wood & Hughes, composed of William Gale, Jacob Wood and Jasper W. Hughes. From the first day he evinced an unusual interest in his work, and a peculiarly active power of acquisition. It was not long before he became a skilled artisan. In 1845 the firm dissolved, Mr. Gale retiring, and the business being continued by the remaining partners under the title of Wood & Hughes. The business was then at 142 Fulton street. A year later Mr. Wood died, and Charles Wood, his son, and Mr. Fraprie were entered as junior partners to take the place of the deceased. Mr. Fraprie took charge as foreman of the manufacturing department, combining that duty with considerable selling in the office. Though not essentially a designer, he conceived numerous beautiful and artistic patterns, and it is said that if he had applied himself solely to designing, he would have been considered a foremost exponent of that branch of art. In 1853 the business, factory and office were removed to 102-104 Fulton street, and in the same year he entered the firm as a full partner. The store at 16 John street was opened in 1873. From that time the deceased almost entirely gave up factory duties and applied himself unceasingly to the business affairs of the store. At which he was a daily attendant till within the few days previous to his decease, scarcely ever missing a day outside of occasional vacations.

The characteristics of the deceased gentleman that stood out in strong relief were his deep interest in his business and his geniality of disposition. He ever considered it his main aim in life to improve his business, and that he realized his ambition is evident from the fact that it was principally through his exertions that Wood & Hughes were for a number of years the largest manufacturers of sterling silverware in the country. Shrewd, far-sighted, thoroughly methodical, the personification of integrity and liberality, it has often been expressed that as a business man he was unsurpassed. Though retiring in disposition, seeking no public fame, and averse to all ostentation, he collected about him a wide circle of friends, who almost revered him for his generous and charitable character. He was never married, but leaves an aged brother with whom he had lived for many years.

DAVID DINKELSPIEL.

Members of the trade of a quarter of a century ago will vividly remember the figure of David Dinkelspiel, who died on Sunday evening, December 15, at his home, 61 West 52d street, New York. The deceased was in his seventieth year, at the time of his death, and in his day as member of the firm of Dinkelspiel & Oppenheimer, was one of the most prominent wholesale jewelers in the country. For the past twenty years he had taken no actual interest in business.

Mr. Dinkelspiel was born in Nuchelfeld, Germany, in February, 1819. He came to America in 1849, and almost immediately commenced the business of importing jewelers' and watchmakers' material, associating himself with Edward Oppenheimer, under the firm name of Dinkelspiel & Oppenheimer. Their business was at 32 John street. The firm shortly afterward removed to 8 Maiden Lane, when they soon attained a reputation as large importers of Swiss watches. During its whole career, until its retirement twenty years ago, the firm name of the house remained unchanged. After his retirement, Mr. Dinkelspiel, as did his partner, interested himself in real estate operations, in which he was very successful, and amassed a considerable fortune.

Undoubtedly more houses originated with Dinkelspiel & Oppenheimer, than with any other firm in the jewelry trade, among them being Oppenheimer Bros. & Veith, Max Freund & Co., May & Stern, late Stern & Stern, Marx & Weis, Adolph Goldsmith, Henry Zimmern & Co., Falkenau, Oppenheimer & Co. and Henry E. Oppenheimer & Co., New York; S. B. Dinkelspiel & Co., San Francisco, Cal; M. Kronberg & Co. and Henry Oppenheimer's Sons, Chicago, Ill.

The deceased leaves a widow, four sons and two daughters.



The "Double Event" Prize Cup.

THE magnificent specimen of silverware illustrated above is the handiwork of the ingenious artists and skilled artisans of the Gorham Mfg. Co., Providence and New York. Undoubtedly it is among the finest achievements in *repoussé* work, the undercutting of the figures and ornamentations being so marvellous in execution, that the details stand out in almost entire relief, and convey at first the impression that they have been applied rather than they are of the same piece of metal as the body of the article.

The illustration represents the "Double Event" cup of the Coney Island Jockey Club won by the three year old "Torso," the property of W. L. Scott, the coal baron of Erie, Pa. The word "cup" has come to be applied to almost anything in the shape of a prize given in athletics and sports, and is thus often of ambiguous significance. In the present instance, the term is essentially correct, and the outline is perfect in curve and proportion. It stands 22 inches high and rests upon an ebony base.

The design, taken as a whole, is thoroughly renaissance. The striking feature is the four horses exquisitely modeled in high relief. They are depicted at the breakaway, and their strained attitudes are true to the life, every detail of muscle and vein being naturally reproduced. The horses form the foreground of the racing track, and in the distance, delineated with the skill of a painter, is seen the

grand stand with its excited throng, shrubbery, etc. Clouds of dust rising from the track are also faithfully reproduced. On the handle sits a figure of Victory holding a wreath with her left hand; this figure is also true in detail and fine in execution. Twisting through and intertwining about the lower portion of the handle are wreaths of laurel uniting with the natural acanthus. An attached figure of Cupid surmounts the cover and supports a cartouche ready to have engraved on it the name of the winner. The spout is a curious formation of the German Gargoil, sufficiently supernatural in design to be true to the ideal of the myth. The cornice over and the base below the landscape are hammered in relief, the design being the blending of shell ornaments, forget-me-nots, and roses. The workmanship of these details is particularly delicate.

The price of the cup was \$1,000, but intrinsically it is worth more. The following autograph letter was received by the Gorham Company from Mr. Scott, and tersely expresses the general opinion obtaining among the racing fraternity:

ERIE, PA., November 30, 1889.

The Gorham Mfg. Co., New York City.

Gentlemen: The "Double Event" cup was received to-day and I desire to express to you my high appreciation of it as a work of art.

Yours very respectfully, W. L. SCOTT.



[FROM OUR SPECIAL CORRESPONDENT.]

CHICAGO, Dec. 20, 1889.

The topic which has caused most discussion amongst Chicago clock dealers and jewelers during the past few weeks is the so called assignment of Geo. A. Harmount of the G. A. Harmount Electrical Co., it having been generally reported by contemporaries of THE CIRCULAR, that Mr. Harmount had made an assignment conveying assets of \$34,000.00 and admitting liabilities of \$41,000.00. In justice to Mr. Harmount, who is well and favorably known here, your observer gives his statement of the affair.

"To start with" said Mr. Harmount, "I have made no assignment and purpose making none, nor did I ever sign any papers of assignment. If anyone signed my name he committed a forgery. Neither has the G. A. Harmount Electrical Company made an assignment; as for its liabilities they amount all told in round numbers to \$10,000.00, \$8,000.00 of which is owing to one man, Mr. Alfred F. Moore the maker of electrical supplies in Philadelphia, and none of which is due. Since the so-called assignment Mr. Moore has written us an assurance of his absolute confidence and faith both in us and in our business affairs."

"The whole trouble arises" continued Mr. Harmount, "From the scheming of H. G. Smiley, who had been in my employ for fourteen months prior to last July on a weekly salary of \$30.00 and a certain percentage of the profits of the business over a certain amount. By the terms of my contract with him I was obliged to give him six months notice, which I did July 1st, but inasmuch as he had overdrawn his account heavily, he had more than used up whatever salary might be due him for the six months ending January 1st next, nor has he spent any time here since July. He endeavored to bring suit against me in October, through Justice Wallace, who decided that he had no case. He then took it to another Justice court on the North Side, where the same decision was rendered. Then he began suit in the Chancery Court claiming that the company had made a profit of \$7,000.00 and that he was wrongfully deprived of his position. This suit was still pending at the time Smiley attempted to make an assignment of the G. A. Harmount Electrical Co., in which he had no interest; nor had he any knowledge of its affairs, as shown in his claim that the liabilities were four times their actual amount."

From outside sources it was learned that Mr. Harmount himself is well situated financially, and that his wife is the daughter of the president of the New Haven Clock Co., for which company Mr. Harmount is the western agent.

Chicago's jobbing jewelers are beginning to fight shy of Kansas City customers. Norton & Butters, whose establishment was taken possession of by the mortgagees on December 14th, owed quite a number of houses here including the Seth Thomas Clock Co., and the Geneva Optical Co. Mr. Smith of the latter company received telegraphic notice of the condition of affairs, but on his arrival at Kansas City he found the Union National Bank, The Keith Furniture Co. and other creditors having mortgages aggregating \$12,000.00 already in possession of the store. This is the concern that went to Kansas City from Boston in January, '88, claiming assets of \$50,000.00 and liabilities of one-half that amount. This failure following so closely on the heels of the Joe. Schwartz collapse and the failure of Pond, Wilmes & Co. of last March still fresh in mind, has created what the Jeweler's Mercantile Agency terms a feeling of great "moral hazard" in connection with the Kansas City jewelry trade. It was rather amusing to read in a weekly journal of December 14th, "Norton & Butters of Kansas City are doing a fine business." It

was on December 14th that the mortgagees took possession.

All these failures in one town notwithstanding, Chicago's jobbing jewelers feel entirely satisfied with the outlook for western collections, and it is not expected here that the January crop of failures will be as large in 1890 as in previous years. "Collections rule good and the prospects are favorable" is the report of all the jobbers.

As for the volume of the jobbing jewelry trade of Chicago for 1889, it will be found to have been largely in excess of the year previous. All the leading houses can show an absolute record of increased business. The Waterbury Clock Co's agency here will report the largest year's business since 1872. The Geneva Optical Co's trade since July 1st, '89 has been greater than for the entire year previous. Morse, Mitchell & Williams report a trade very much greater than were their expectations. Simpson, Hall, Miller & Co's western agency has never had such a trade, and it is keeping up to the last days of this old year.

Notwithstanding the rush of business, most of the large jobbing jewelers can be seen on two or three nights of a week in attendance at the opera festival now in progress here, and on "Patti Nights" very few of the shining lights of the jewelry trade are missing. The retailers are waiting until after Christmas Eve, as the stores of all of them are open evenings.

The New Haven Clock Co. have just put on the market a new electrical clock, which will sell to the jobbing trade at from \$25.00 to \$30.00. They claim it to be more desirable than any other; also, that it requires less electrical power.

Lapp & Flershem issued in the early part of the month a colored sheet illustrative of the newest designs in silver novelties, which had the effect of increasing their already very large sales.

The Roy Photo-miniature introduced here recently for the photographing of the features of wife, husband or sweetheart on the inner case of a watch is becoming very popular in this city. Joseph & Fish have thus far controlled it.

Mr. E. W. Prentice, the veteran manager of the Chicago branch of the Gorham Manufacturing Company, and who has been in their service since 1862, never had so much reason to be thoroughly satisfied with the result of his year's work. Heretofore the reserve stock in the warerooms here has not been exposed; this year every article in the establishment is needed to fill up the show cases, which even then look lonesome; in truth the stock which filled the Chicago warerooms of the Gorham Company has disappeared, leaving no trace except a well filled sales book. Mr. Geo. Wilkinson, superintendent of the Gorham factory, and known as perhaps the most artistic designer of fashions in sterling silver in this country was here last week.

The new patterns of the Towle Manufacturing Company are a great hit among the western trade. Mr. Todd is pushed to the utmost with orders and calls this the busiest season in their history.

Mr. E. Howard of the Howard Watch Co., of Boston, visited Chicago recently. Mr. Joseph Schweitzer, general manager of the Ansonia Clock Co., has been visiting Mr. E. D. Barnum, its western manager and returned to New York a few days since.

Joseph & Fish are about to lose a valued employee. President Frink of the Chicago Horological Institute has found that the growing importance of that institution will require his undivided attention after January 1st, and he will at that time cease to be associated with Joseph & Fish.

Even at this time of the year the Chicago jewelers are not allowed to forget the National Game. In several of the offices of both the jobbing and the jewelry trade are to be seen well framed photographs of the Meriden Britannia Co's base ball club, which captured the prize pennant of the Commercial League during the past season. Mr. A. L. Sercomb, the Western Manager of the Meriden Britannia Co., whose enthusiasm for the game called the M. B. Co's B. B. C. into being, appears in the background of the picture.

One of the Chicago jewelers was instrumental in procuring the

conviction of the Cronin murderers; the testimony of Alfred Ketter materially helped the State in proving Coughlin's presence near the Carlson Cottage on the fateful May 4th.

There have been scarce any out of town jewelers in this market during the month, and 'it woun'dn't speak well for December trade if there had.

Mr. G. J. Corey, manager of the western branch of the Pairpoint Manufacturing Co., is about worn out, so excessive have been the demands of the last month upon him. Their line of old silver bonbons, toilet sets, manicure and ink sets has been a decided success, and the factory has been kept running 14 hours a day to supply the trade with these goods.

THE CIRCULAR'S OBSERVER.



[FROM OUR SPECIAL CORRESPONDENT.]

BOSTON, December 21, 1889.

Of course we are now in the middle of the holiday rush and roar of trade. That fact there is no need of emphasizing.

Of course, too, the minds of our conservative business men are even yet more or less filled with anxious memories of the narrowly escaped disaster threatened the entire city by the recent conflagration.

Both subjects have already been worn threadbare, and there is no need now of going into a perspective detailed account of "what might have been."

The general features of the market are perplexingly uninteresting. Even the iron and steel industry which has long been characterized by a buoyant temper is now quiet, not through any change in the prospects, but because of a general disposition to defer new engagements until after the new year. The railroad situation locally continues to show a good degree of improvement in various ways. The Atchison management have passed through their re-organization crisis successfully, and the reports are most encouraging to investors. This has eased up a little mite the embarrassing stringency that characterized the private purses of our Back Bay residents, immediately after the speculative surprises of last Summer. People have begun again to be more liberal both in their wants and in the gratifying of them. The result of it all is most gratifying to those of our dealers whose business success depends upon the sale of Christmas luxuries.

It doesn't take more than half an hour's casual circulation among the retail jewelry trade of this city to reach the general opinion that the sales for the present month will show up in their total footings quite as imposingly as they did at this time a year ago. There isn't a store on Washington street that isn't being daily crowded to suffocation, and the best of it is that people seem to have come down town after having "put money in their purses" with the fixed determination of taking it out again before their return home. Of course it is easy enough to find a few merchants who look back at the good old times of last Winter, and complain a little more at the comparatively lethargic character of the present trade. But the man who is contented with a steady run of buyers rather than an erratic and hypercritical swarm of pickers-over has little cause for fault finding.

One thing is peculiarly noticeable among both the wholesale and the retail houses, though to be sure the latter are more generally affected by it, and that is the unusually late appearance of the Christmas rush. One can't feel, you know, that all is quite "peace on earth and good will to men," when warm days and drizzling rains combine their depressing influences in the middle of December. The streets have been too slippery with mud for the timorous and

tasty to venture out for present buying. When they do come it will be all at once.

In the large and busy establishment of James Tufts the men have been working till 9 o'clock every night now for two months, and Mr. Stone who has charge of the salesrooms says that his books show the sales for this month to be just double those of last December. So, of course, he put it down as an unusually good year.

The Bigelow Kennard people report that business is way up with them one day and way down with them the next. They figure the situation as only fairly good, and say the general fluctuation and uncertainty averages about the same as last year.

Mr. Floyd, of Floyd, Pratt & Rounds, rates the present trade as good, and doesn't see much difference from that of last year. When asked about the moonstone fad he expressed the belief that it had come to stay. "It is he added a unique craze, and we can notice no decrease in the demand as yet. The moonstone is still in high favor on Beacon Hill."

The Ripley, Howland Manufacturing company were seen, and when asked how the trade was said that they didn't have time to stop and think what the trade was hardly.

"We are driven to death," said one of the partners. "We have all we can do and more, in fact we can't fill our orders and will be obliged to run behind them. We have never seen anything like it before. Last year was nothing compared to this. Why we are simply rushing and hustling to do our work. You speak of moonstones, they are selling finely, and I think that they will continue to do so. We are selling a great many diamonds and colored stones. But the business was never better than it is now and has been all the fall."

D. C. Percival & Company have been too busy to do more than give the brief information that they were running every night till 11 o'clock, and that they had all they could do and more too. They have never had a year like this before, and last year is hardly to be compared with it.

Tobey, Craig & Co. is the title of a new jewelry firm located at 56 Boylston street. Its main business is done on the instalment plan. Rufus T. Tobey, James Craig and Charles H. Schofield are the members of the firm.

Some of the dealers hereabout have been much interested in the reported discovery at St. John, N. B., of J. T. Humphrey, Lynn's missing jeweler. He disappeared last April. The story is that he has made a deposition favorable to the early settlement by his estate of the suit now pending with Morrill Bros. & Co. of this city.

Optician John Green has opened a manufacturing establishment at 11 Meridian street, Boston.

A woman has just joined the jewelry trade of this city. Mrs. Lydia J. Yong has gone into partnership with Max Carlton, under the firm name of M. Carlton & Co., at 873 Washington street, where Louis Bonnie was formerly located.

James A. Loughton has left Palmer, Batchelder & Co., and gone into the Western mortgage loan business.

Elson & Richards are concentrating their enterprise and energy upon their Park street store. The Beacon street branch has been relinquished.

The jewelry trade was peculiarly fortunate in escaping any serious injury from the recent fire in this city. William Kahle, casemaker, at 74 Chauncey street, suffered a total loss, but his insurance has already enabled him to start anew at 27 Hayward Place. Manufacturer Robert J. Ford, who was located in the same neighborhood, also lost everything.

All our retail stores are making handsome holiday displays in their windows. The Shreve, Crump & Low Co. are making a specialty of Barye bronzes.

Herbert M. Federhen recently retired from the presidency of the City Council of Quincy, and he was given a farewell complimentary banquet at Young's Hotel. There were a great many of Mr. Federhen's business as well as political acquaintances present, for to many he is best known as a member of the jewelry firm of John Federhen & Son.

LEON.



[FROM OUR SPECIAL CORRESPONDENT.]

PROVIDENCE, R. I., Dec. 15, 1889.

The business for the year 1889 which is about closing, has been very satisfactory on the whole. The Spring trade was not so heavy as might have been expected, but the Fall and Holiday business has made up for the deficiency. The increase in amount of sales over the year 1888 will easily figure from ten to thirty-five per cent., with even better prospects for 1890. Closing books and taking stock is the order of the day at present to find out as accurately as possible how much has been gained during the past twelve months. Many firms will find a neat balance left to their credit on the proper side of the ledger. Samples for the coming Spring trade are well under way and will be ready by the 10th to the 15th of January, the Western buyers not caring to see them before that time, as they feel that goods are being forced on them earlier every year, by some really before they have taken stock, with most disastrous consequences. Failures during the past month have again come to the front with unpleasant frequency and the National Bankrupt Law cannot pass at Washington any too soon to please the Eastern manufacturers, so that confessed judgments and preferred creditors will be entirely out of the question. Judge Lawrence gave a very good opinion to this effect in the Payne, Steck & Co. failure recently.

Hardly had the excitement attendant on the failure of Stern & Stern subsided before it was announced that the stock of David Wolff, of Auburn, N. Y., had been seized by the sheriff and that the manufacturers located here were in for about \$50,000.00. Wolff is said to be closely related to the firm of Stern & Stern and their methods of transacting business were nearly identical. Both of these failures will admit of very close scrutiny, and will undoubtedly get it from our Board of trade.

A boom has struck the factory of Ostby & Barton, the well-known ring makers, of this city, and they are running over time and adding constantly to their force of help to fill the orders that are pouring in upon them. They now have about 120 hands at work, and expect soon to be pushed to the extent of their facilities, although these were greatly increased recently by the addition of another floor to their factory and numerous other improvements. Their well-known line of band rings will be shown in greater variety than ever before. The Triple Crown filled ring, of their manufacture, has long since become a staple with the trade, and they are prepared to offer this season a very extensive line of fancy rings at prices that will defy competition.

The New York office of Hamilton & Hamilton, Jr., in the Corbin Building, are fitted up in luxurious style. A handsome moquet carpet yields to the tread, the walls are painted in warm harmonious colors, and the furniture would not be out of place in a parlor. With two such genial hosts as Messrs. Ralph Hamilton and J. G. Fuller in charge, customers will be certain to receive entertainment in every way suitable to such elegant surroundings.

Foster & Bailey, 60 Richmond st, find it necessary to utilize every inch of space at their establishment, so great is the pressure of orders. Changes looking toward greater economy of production are constantly being made to keep pace with the increasing popularity of the "Mount Hope" sleeve buttons, the new plated glove buttoner and calendar locket, ladies' and gents' chains—a new line—and their salable line of novelties in charms, brooch and bar pins, lockets, scarf pins, etc., to which new patterns are being added daily. This firm appears in the market this season with the finest show of samples they have ever had.

A. V. Blake can now be found at No. 107 Friendship st. John Austin and M. Fitzgerald were re-elected as Directors of the Mercantile Trust Co. at their last annual election, held on Wednesday.

Calvin Stone of Isaac Stone & Co. has been attached for the amount of \$2,000.00.

Peter Crassin has started in the manufacturing jewelry business at No. 409 Pine street under the firm name of Peter Crassin & Co.

J. C. Harrington's offer of compromise of twenty cents on the dollar has been accepted by his creditors. J. C. Harrington & Son is the style of the firm which succeeds the late concern of J. C. Harrington. They will continue business at the old stand as formerly.

R. A. Kipling sailed for Havre, France, per the French Liner *La Normandie*, on Saturday, the 14th inst. He will return about July next.

Edwin Lowe was re-elected Alderman, and Geo. L. Vose and Hoffmann S. Dorchester, Councilmen, at the recent Municipal election.

Manufacturers are very much pleased with the decision handed down by Judge Lawrence in the New York Supreme Court, Special Term recently, making the assignment of Payne, Steck & Co., void and the confessed judgments illegal. Rightful creditors will now have a chance of getting something as the Judge in his decision says it was already proven that Wm. H. Payne withdrew from the firm's assets about \$46,000.00, none of which went to the creditors.

The failure of Stern & Stern, of No. 13 Maiden Lane, New York City, involved the manufacturers here to the extent of \$40,000.00. George L. Vose and Wm. A. Ballou were appointed a committee to investigate the affairs of the firm which they found to be in the worst possible way. A thorough investigation is in progress.

Hancock, Becker & Co., 40 Clifford street, the well-known manufacturers of imitation diamond jewelry, were so pressed with orders for their popular goods up to the very eve of the new season, that they could see no dividing line. Notwithstanding this fact they are in the market with a remarkably fine line, embracing many specialties that the trade should inspect at an early date.

Silas S. Manchester, of Fessenden & Co., declined the nomination for councilman at the recent municipal election.

S. C. Howard has returned from his recent trip to California.

Albert Lorsch & Co. are now represented in this market by E. Slade and Frank Doughaday.

F. T. Pearce & Co. are meeting with great success with the Livermore fountain pen.

The Brown & Sharpe Manufacturing Co. have just issued a supplement to their already extensive catalogue. This concern, it is safe to say, makes more manufacturing jewelers' tools and supplies than all others engaged in that line of business.

N. B. Barton, of Ostby & Barton, has just returned from a prosperous western and southern trip.

W. A. Beatty & Co. are about to put some new designs on the market in the specialty line of jewelry. They claim to be the largest manufacturers of hoop earrings in the world, and the extent of their new line substantiates the claim.

Schofield, Lambert & Co., formerly of Plainville, have located in the quarters at No. 226 Eddy street, formerly occupied by Hamilton & Hamilton, Jr. Clark & Coombs have also moved to this city from North Attleboro, locating at No. 21 Eddy street.

Hutchison & Huestis, Kent & Stanley, Fowler Bros., Fessenden & Co., S. B. Champlin & Son, W. C. Greene & Co., S. K. Merrill & Co., and D. R. Child & Co., are some of the firms who distributed cash and turkeys to their employees on Thanksgiving Day.

Fred. I. Marcy has been elected one of the board of managers of the Old Mens' Home.

Kent & Stanley find that the requirements of their business compel them to run their works until 9 o'clock at night excepting on Saturdays, to keep up with orders now on hand. FAIRFAX



[FROM OUR SPECIAL CORRESPONDENT.]

THE TWIN CITIES AND THEIR TRIBUTARIES.

MINNEAPOLIS, Minn., Dec. 13, 1889.

In spite of the continued warm weather, trade in the jewelry line has been eminently satisfactory. The Minneapolis Jewelry Manufacturing Co. say their whole year's business has been much better than last, and this month's far ahead of the same last year. Reed & Dailey report their's fifty per cent. better for the last month than at the same time in '88. They say their business for the twelve-month has averaged better than for the last two or three years, but does not reach the high water mark of old boom times yet. They have had a good holiday trade in silver novelties. Warner & Co., also attest to a good year and a big November trade.

Retailers, of course, are in their element. Eustis Bros. have an especially large and costly stock for the holidays. They say, Minneapolis, rich as she is and growing as she does, must have the best; and indeed Minneapolis women do wear fine jewelry. H. F. Legg has had a successful year, too, and reports the last month's silver article trade large.

The kickers have enjoyed life since the clock was put up in the new Minneapolis government building a month ago. They are now calling loudly for telescopes, for the hands are so small that only the birds of the air can tell the hour way up in the tower. The clock was manufactured by J. Barborka of Iowa City, Ia.

A good deal of interest is felt in the jewelry fraternity here by P. F. Egan's deserting the ranks in St. Paul where he has been located since 1850. He is a brother-in-law of P. H. Harris, owner of theatres in Baltimore, Cincinnati, and other cities, and who has recently bought theatres in St. Paul and Minneapolis. For this reason Mr. Egan is selling out, to take charge of the Harris theatres in the twin cities.

A medium-sized man with dark features and aquiline nose, gold-headed umbrella, diamonds and all that, walked into the Merchants' Hotel, St. Paul, the 15th. Then he walked out again with a detective. The man was Frank J. Schwartz, wanted in Kansas City for doing away with \$40,000 worth of diamonds and other jewelry. Schwartz would probably have been wintering in Canada by this time were it not for the fascinations of one of the demi-monde, who it was found had left for St. Paul about the time of his disappearance. A few hours before his flight he bought \$2,675 worth of diamonds from the traveling salesman of the Philadelphia diamond house of S. M. & S. R. Fridenberg, paying but \$500 down.

The police recently unearthed a rich treasure in a sand pit on the Rock Island road just east of the fair ground, the same being no more nor less than a good-sized valise full of fine jewelry and other costly articles. From the knowledge that the jewelry store of J. P. Fasedach, at Mason City, Ia., was burglarized on the night of the 24th and other circumstantial evidence, it is presumed the thieves dropped the valise in the pit while coming in on the train and failed on search to find the spot where they dropped the valuables.

It is reported on good authority that a tract of land in Eldorado Bar, Montana, has been sold to a syndicate of eastern speculators for \$150,000. This is the land about which there has at times been a great deal of excitement over the discovery of garnets, rubies and other precious stones. It is also said that the purchasers will bring out machinery to work the ground for the placer gold it contains, as well as for its precious stones.

A. A. Michael & Co., jewelers of Kansas City, have assigned with liabilities, \$80,000; assets, \$75,000.

The store of E. L. Stevens, jeweler, Sioux City, Ia., has been closed by the sheriff on two chattel mortgages of \$3,000.

Brobeck & Roe, of Kenyon, Minn., are selling out their jewelry business.

The jewelry establishment at Stillwater, Minn., owned by F. Willman, has been bought by J. S. O'Brien, of the lumber firm of Anderson & O'Brien.

Henry Langstaff has sold his jewelry house at Bristow, Minn., and is traveling for a Des Moines jewelry house.

C. F. Tryon, of Wabasha, Minn., will open a jewelry store at West Superior, Wis., on the 1st of January.

L. Sheridan has opened a jewelry store at St. Charles, Minn.

Watertown, S. D., wants a watch factory. Dec. 6th, ex-mayor Gesley left for Boston to meet a delegation of Watertown citizens for the purpose of perfecting the arrangements for a watch factory to be located at that place. The buildings and machinery, according to the terms of contract, must be worth \$250,000.

HENDERSON.

The Jewelers' and Tradesmen's Company.

During the last month the following named have been granted certificates of membership: John H. G. Durant, New Haven, Conn.; John McKinlay, Charles C. Pienge, Charleston, S. C.; Wm. F. Renziehausen, Glorieux & Woolsey, Newark, N. J.; Daniel Heerd, Lyman W. Sutton, Stamford, Conn.; William A. Hawes, Greenwich Bank; Joseph J. Lafetra, Calvin W. Shipman, Charles J. Evans, William Kuchler, Herman S. Kolbusch, Jr., and Jacob Loeb, New York City.

Much interest has been manifested in the proceedings on the part of an attorney or collector to secure a larger sum than was proffered to the beneficiary of the first deceased member of this company, Elbert E. Wadsworth.

The company gave a check for the amount of the benefit, according to its interpretation of the constitution, and the check was returned, the attorney bringing suit for a larger amount. The matter went before Part II. of the Superior Court, presided over by Judge Truax, and an opinion was rendered that the attorney was entitled to more than the amount tendered by the company, but not for as much as was claimed.

The decision of the court is regarded by the company as so much at variance with the equities of assessment insurance, that, with the interest of all of its members in view, it has decided to appeal the case to a higher tribunal.

It is a principle of assessment insurance well known to those even moderately conversant with it, that a young company cannot pay to a beneficiary any larger sum as a single benefit, than the contributions to its mortuary fund by each of its members; when the amount of such mortuary fund, increased by its increased membership, amounts to the maximum amount of the certificate of membership, then and not until then is an assessment society expected to pay its certificates in full. Such has been the experience of every assessment society.

The deceased member's certificate was for a maximum face value of \$4,000. As the largest certificate issued was for \$5,000, the company, in equity and in accordance with the intent and interpretation of its agreement with its member, paid four-fifths of the amount of the mortuary fund to his beneficiary, and such was the understanding of the member, as expressed to one of the directors, at the time of joining.

The company, in justice to its other members, has decided to fully contest the claim of the attorney for more than the proffered amount. It will not compromise unjust claims upon its membership and its mortuary funds, even upon the plea of expediency.



[THE CIRCULAR is not responsible for the opinions or statements of contributors, but is willing to accord space to all who desire to write on subjects of interest to the jewelry trade. All communications must be accompanied by a responsible name as a guarantee of good faith. No attention will be paid to anonymous letters. Correspondence solicited.]

OF INTEREST TO LATHE MAKERS.

To the Editor of the Jewelers' Circular:

Watchmakers living in the country are often called upon to do many odd jobs that are too large to be done on a watchmaker's lathe, whereas, if they had a back-gear, screw-cutting engine lathe of about 7 or 8 inches swing that could be run by foot power, such jobs could be easily done. But a lathe like the above, made for fine and accurate work, I have been unable to find. There are screw-cutting lathes for sale, but they nearly all have this one defect, *one lead screw*, that is used both for turning and screw cutting, consequently, the screw soon gets worn and is unfit for accurate screw cutting. There should be two leading screws, one for fine screw cutting and the other for regular turning; or, if one lead screw is used it should be *slotted*, and operated with open and shut nut for screw cutting, and with sleeve gear (the same as rod and friction feed in large lathes) for regular turning. It should also have a hollow spindle to take the regular standard split steel chucks. If you would make this want known in THE JEWELERS' CIRCULAR, I think it might be the means of leading some one that has the facilities to do so, to undertake to make some.

EXPERT.

BANKRUPT LAW—A SUGGESTION.

To the Editor of the Jewelers' Circular:

The principle upon which a claim for a National Bankrupt Law is based, is that there are other claims upon the individual besides that of paying what is due to creditors, and, it may be argued, prior claims, to wit: the claims of wife and children to be supported by the debtor. In times past these latter claims were ignored and the delinquent was put in jail and there punished for his inability to pay.

Now, the public sentiment is different, and the majority of thinking people feel that where the debtor has made an honest failure and a complete surrender of his property, deducting what the law allows him, he ought to go free. However it may be with other dealers, this, to their honor it may be said, is the sentiment of the members of the jewelry trade.

A bankrupt law therefore ought to accomplish two things—

1st. The release of the debtor after an honest surrender, and *immediately*, and—

2d. The delivery to the creditors of his property as aforesaid.

Now, how can all this be accomplished? There would be no difficulty in the case if the Jewelers' Association could manage the matter. It would not take a fortnight to fix up any failure, but it must not be forgotten that lawyers make the laws. They control legislation, and they make laws for the benefit of lawyers, and it will be found that if the next Congress passes a bankrupt law, it will be full of complications which will enable the lawyers to get all the debtors' effects as heretofore.

Now in view of the above I make this suggestion.

Let the jewelry trade make a bankrupt law for itself, and give it publicity as in honor binding as between debtor and creditor.

And here it is—

1st. The Association shall have a committee to take charge of all failure cases.

2d. The manufacturers and dealers, jobbers, &c., and all who are likely to become creditors, whether members of the Association or not, shall sign an agreement to abide by the settlement made by the

aforesaid committee, and this list of dealers shall be sent out to the buyers generally, so that they may know what they may expect in case of failure; with instructions how to act in case of failure, so that the failing party may have the benefit of an adjustment by said committee. A form of assignment should be made so that no lawyer need be employed except the one representing the Association.

Now in case of a failure being necessary, let the assignment be made to the aforesaid committee or their representative, reserving all legal rights to exemptions, in accordance with the state law where failing debtor resides.

By this act the debtor puts himself under the protection of the Jewelers' Association, and is entitled to all benefits arising from that act. The Association will stand as his friend in this great need.

The Association binds itself, that when a debtor shall *honestly* surrender, as mentioned, that instant he shall be acquitted of all his debts. No delay. He has given up all, and that pays all.

The committee of the Association having thus been put in possession, shall proceed to investigate, but the debtor's discharge is to be conceded at once, and remains valid and final, unless fraud shall be discovered.

Now the ownership of the property, having changed from the debtor to the Jewelers' Association, it will be the work of this committee to dispose of it, which may be done in the way they think best.

In most cases, no doubt, it will be sold back again to the failing party, but the creditors and not the lawyers will get all there is in it.

If the Jewelers' Association sees fit to do so, they may establish a rule, that any jeweler failing and not assigning as pointed out, shall not be entitled to the benefits aforesaid.

If deemed best let the entire trade sign an agreement, that in case of failure, they will assign as mentioned.

B. E. C.

WHO HAS EXCELSIOR'S "TREATISE."

Would like to buy a copy of Excelsior's "Treatise on the Balance Spring."

L. H., care THE JEWELERS' CIRCULAR.

The Jewelers' Security Alliance.

A special meeting of the Executive Committee was held at the Alliance office on Friday, Nov. 29th. There were present: Vice-Pres. Henry Hayes; J. B. Bowden, Chairman; Messrs. White, Butts, and Geo. H. Hodenpyl, Sec'y.

The following were admitted to membership: Bell Brothers, 16 and 18 Ford street, Ogdensburgh, N. Y.; J. R. Broadstreet, Talladega, Ala.; Philip Bissinger & Co., 22 John street, N. Y. City; Merritt Barnes, Avoca, Iowa; Sumner Bull, Main st., Walden, N. Y.; H. H. Curtis & Co., Elm street, No. Attleboro, Mass.; Millard F. Davis, 9 E. Second street, Wilmington, Del.; Daniel C. Denham, 276 Thames street, Newport, R. I.; Engel & Goodman, 441 and 443 State street, New Haven, Conn.; Benjamin A. Hersey, 465 Washington street, Boston, Mass.; Wm. J. Kelley, cor. Main and Washington streets, Oshkosh, Wis.; Hermann Lange, 17 Arcade, Cincinnati, O.; Lapp & Flershem, 92-98 State street, Chicago, Ills.; S. C. Ledman, 410 W. Market street, Louisville, Ky.; Charles Magnus, 18 John street, N. Y. City; S. T. Morrow, 134 First street, Elizabeth, N. J.; James Milton, 164 Broad street, Eufaula, Ala.; N. C. Nelson, 5 School street, Concord, N. H.; W. W. Parker, Main street, Akron, N. Y.; Chas. F. Pettingill, 160 Hancock street, Quincy, Mass.; Myron C. Prince, 19 Main street, Herkimer, N. Y.; Roediger Bros. & Co., 17 W. Main street, Belleville, Ills.; Rodgers & Pottinger Jewelry Co., 4th and Market st., Louisville, Ky.; R. O. Randall, 426 Broad street, Gadsden, Ala.; Theo. C. Sennett, 278 Manhattan avenue, Brooklyn, N. Y.; Van Houten Bros., 363 Mulberry street, Newark, N. J.; Alonzo T. Ward, 105 So. Jefferson st., East Saginaw, Mich.

Neglected Problems.

No. 2.

WHEEL AND PINION GEARING AS LEVERS TRANSMITTING POWER.

By "EXCELSIOR."

SO MUCH interest has been aroused by the statements about *curved levers* in my article on "Measuring Wheel and Pinion Depths," in THE JEWELERS' CIRCULAR for September, that it is thought best to explain the matter a little more fully. Although watchmakers are mechanics, and should understand mechanical laws, yet the subject of the transmission of power by levers is one of the "neglected topics," little understood by the trade generally.

This may seem a rather startling assertion to make, but as proof of its correctness look at Fig. 1, which represents a system of levers arranged around and revolving upon the axis or fulcrum *A*. 1, 2, 3, 4, 5, are weights of, say, 1 lb. each, suspended from the different levers as shown. The weight 1 pulls on lever *B*, and tends to revolve the system on its axle *A* with a certain power. Lever *C* is just as long as *B*, and weight 2 is the same as weight 1. But all can understand at a glance that it does not revolve the system with the same power as weight 1.

Weights 3, 4 and 5 run over pulleys, as shown. The pulleys do not affect the amount of power exerted by the weights (except by a slight loss from friction, which we will suppose to be too small to take into account), but they enable us to make the weights pull in any direction that we wish.

Weights 2, 3, 4 and 5 are all the same, 1 lb. each, and the lever *C* has the same acting length in all four cases, but each weight exerts a different power upon the system. Now how many watchmakers can calculate the power with which each weight tends to revolve the system upon its fulcrum, axis or "pivoted arbor" *A*?

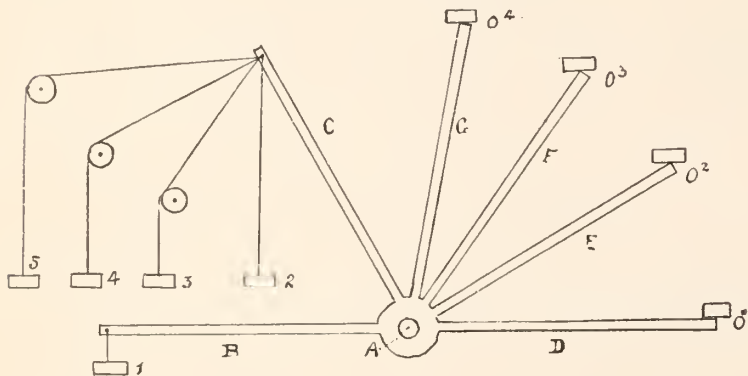

This power is of course exerted upon something, *i. e.*, it is expended in doing some kind of work. Let us suppose that the work we wish to do is pushing some object vertically upward. Let the arms or levers *D*, *E*, *F*, *G*, all be just the length of levers *B* and *C*, and suppose that we want to raise the weight *O* with them. All can see that these levers do not act with the same power against O^1 , O^2 , O^3 , O^4 , but how many can tell what the power is in each case?

And yet these things are at the very foundation of all mechanical knowledge. Fig. 1 represents precisely what occurs in some form in every wheel and pinion gearing, and if the watchmaker does not know them, what does he really know about the mechanical principles of the train, or of gearing generally? Unfortunately, it is too often the case that our knowledge is more of the practical details of working than of the theoretical principles which underlie and govern those details. If all mechanics were as well versed in the theory as in the practice there would be fewer defective and abortive mechanisms, and perpetual motions would no longer appear.

The subject of levers, powers, etc., is generally considered exceedingly dry and difficult, but I shall hope to make it both clear and interesting, though perhaps, at the expense of that "conciseness"

which most writers seem to strive after more earnestly than they do to make their meaning intelligible and unmistakable.

I am aware that this is promising a great deal, more than any one has yet accomplished, but if my readers will simply read these articles carefully I will undertake to make the subject so plain that they shall understand it, and without much studying over it.

FORCES, POWER, WORK, ETC.

In the first place, let us clearly understand what we are dealing with, *i. e.*, what is meant by *force*, *power*, *energy*, *work*, etc.

The *natural forces* are the forces of nature or physical agents acting upon matter, such as *gravitation*, *heat*, *light*, *electricity* and *magnetism*, etc. They are now believed to be different forms of manifestation of the *energy* of nature, *i. e.*, different "*modes of motion*" produced by that energy, and they are also believed to be interconvertible, *i. e.*, one form of energy (or mode of motion) can be converted into another form, as, for instance, electricity into heat, heat into light, etc. These transformations have actually been made, and according to the eminent German scientist, Dr. Werner Siemens, the present writer was the first person to convert the energy of light directly into electrical energy* (or, as generally phrased, to "convert light directly into electricity"), thus completing the circle of these transformations, and demonstrating the mutual interconvertibility of all the different forms of energy or natural forces.

MECHANICAL FORCES.

What we know by experience as "forces" are simply the *properties* of matter, or the different ways in which bodies present themselves to our senses. Considered from a mechanical point of view, we may explain them as follows:

When a particle or body of matter is at rest it has no innate power to change its state of rest; when it is in motion it has no innate power of changing its state of uniform motion in a straight line. This property of matter is termed its *inertia*. Any cause which sets it in motion, or which changes the magnitude or direction of its velocity when it is already in motion, is a *force*.

The principal mechanical forces are *gravity*, *friction*, the *elasticity* of gases and springs, *contraction* and *expansion*, electrical or magnetic *attraction* or *repulsion*, etc. Inertia is a negative force.

MECHANICAL POWER.

A force, being a manifestation of energy, does work of some kind. Whenever a force produces *acceleration of motion*, or *maintains motion in opposition to resistance*, it is said to do *work*, and the rate at which energy is given out or expended is called the *power* supplied by that force. In other words "power" is *the rate of doing work*.

By long standing custom the larger mechanical powers are estimated by comparing them with the power of a horse. If a steam engine or a water wheel can do as much work per hour as a horse, it is said to furnish one *horse power*, and so in larger or smaller proportions. Neither steam nor water are forces, nor are they powers. They are only the forms of matter or means by which the true forces are enabled to manifest their energy.

In the case of the vapor steam, its *expansion* is the force which is acting, and its energy is utilized by a mechanical device termed a steam engine. In the case of water, *gravity* is the acting force, and generally utilized by means of a water wheel. All weights act by their *gravity*. In the case of a spring, the force which acts is the *elasticity* of the steel, causing it to offer resistance to flexure, or to resume its previous form as rapidly as the resistance will allow.

In the case of the horse, the force which acts is the *contraction* of the muscles, and this contraction is utilized by means of a system of

* See paper on "The Electromotive Action of Illuminated Selenium," read by Dr. Werner Siemens before the Academy of Sciences, at Berlin, on February 12, 1885, in the *Monatsbericht der Berl. Akad. d. W.*, for February, 1885, page 147, 148.

NORUMBEGA was the name of a lost Norseman City, the site of which has been recently discovered by Prof. E. N. Horsford, who erected this tower on the site of a Norseman fort, near Roberts' Paper Mill, at the junction of Stony Brook and Charles River, a suburb of Waltham. "This fort and city were in existence 400 years ago, and for centuries prior to that time."

At that time the old Egyptian lathe was still in use, driven by a strap wound around the pulley of the lathe, passing down to a lever which was forced down by the weight of the human body. Another strap ran from the pulley to a tree which was bent so as to form a spring, which by its recoil revolved the lathe backwards.

Our Mr. Webster saw a lathe run in this way in a case factory in England in 1839.

Please learn the difference between this old-style lathe and the "Webster-Whitcomb" by sending for a Price List.

Antiquarians interested may ask for circular relating to Norumbega.

American Watch Tool Company.

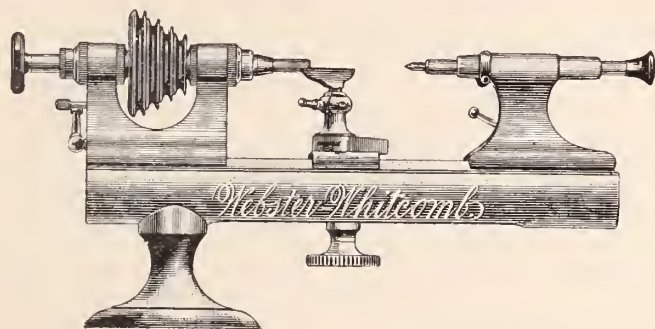

WALTHAM, MASS, Jan 1st, 1890.

The "WEBSTER-WHITCOMB" Lathe was not known in Norumbega.

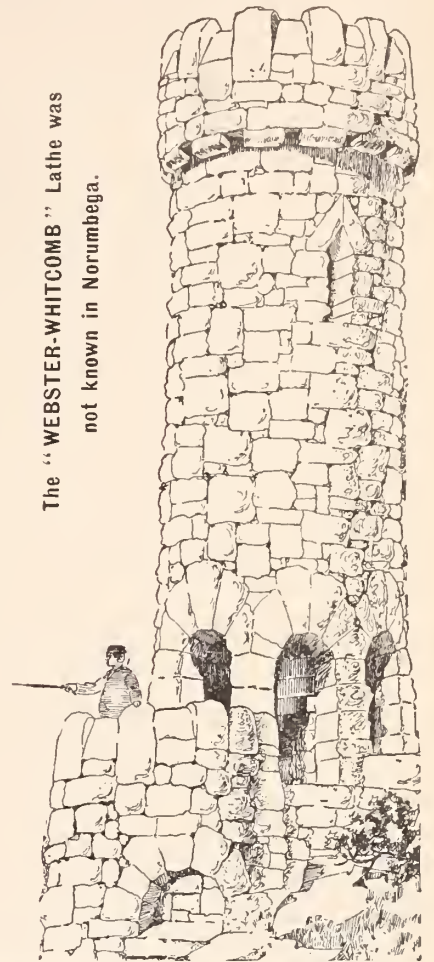

A Hand-Book of Precious Stones

By M. D. ROTHSCHILD.

12mo, Cloth, Illustrated, - - \$1.00.

Special Discounts on Quantities.

The object of this little book is to convey to the merchant, the workman and the amateur, in a condensed and accurate form, information concerning the various properties of precious stones. Besides drawing freely on a number of authorities, the author has used his practical experience to indicate such tests as an amateur can readily make. Specific gravity, hardness and dichroism are tests which are easily mastered, and a thorough understanding of these three properties will assist in classifying doubtful gems. Such stones have been dealt with principally as are used in commerce for jewelry and ornamental purposes.—*Extract from Preface.*

"The book will be found teeming with facts which every dealer in gems should, for his own protection and profit, be familiar. * * * It is not exaggeration of the work of the volume to predict that whoever once reads it will keep it in a place where his hand may be laid upon it at any moment.—*The Jewelers' Weekly.*

"We recommend it to all who need a handy work of reference.—*The Jewelers' Circular.*

C. P. PUTNAM'S SONS,

27 & 29 West 23d Street, New York.

PFORZHEIMER, KELLER & Co.,

24 JOHN STREET, NEW YORK.

—❖ American ❖ Watches, ❖—

—❖ Diamonds, ❖ Jewelry. ❖—

I. PFORZHEIMER }
D. KELLER

J. B. ETTINGER,
H. J. FINK.

WM. JAMOUNEAU PRES. HENRY L. LEIBE TREAS.

ALVIN MFG. CO.

* ART. WARES. IN *

* SOLID SILVER *

* 10 East 14th St *
* New York *

Factory Newark N.J.

A FEW SPECIMENS OF RECENT DESIGNS IN ALVIN ORNAMENTAL

levers, consisting of the animal's bones or "limbs," holding on the ground underneath him, and enabling him to move some object along. The standard of work for a horse is the raising of 33,000 pounds through a height of one foot per minute, and any motor or force which can do that amount of work at that rate is said to give out 1 horse power. If it does twice that amount of work per minute, it gives two horse power, and so of any greater or less amount of work done at that rate.

MECHANICAL "WORK" DONE.

The quantity of work done is measured by comparing it to weights lifted. The unit of measurement of work is called a "foot-pound," which is the quantity of work that is done in lifting 1 lb. through the height of 1 foot. "Work" therefore means the total quantity of work done in a given time, and is ascertained either by measuring that total amount, or, if the work was done at a uniform rate, *i. e.*, the power was constant during the whole of that time, it can be found by measuring the work done in a short space of time, as 1 second, or 1 minute, and multiplying that by the number of seconds or minutes in the given time.

It will be observed that the amount of "work" is the product obtained by multiplying together three factors or elements, *viz*: *weight*, *distance* and *time*. A horse power being the lifting of 33,000 lbs. 1 foot in 1 minute, or of 550 lbs. 1 foot in 1 second, the "work" done in 1 minute is therefore 33,000 foot-pounds, and in 1 second is 550 foot-pounds.

It is obvious that the "work" is the same whether 550 lbs. are lifted 1 foot in 1 second, or 55 lbs. are lifted 10 feet in 1 second, or 1 foot in 10 seconds, or 1 lb. is lifted 550 feet in 1 second, or any other modification of the several quantities is made, so long as the product of the number of pounds, feet and seconds is 550. We may vary either or any of these factors, provided we also vary the others so as to obtain the same final product. If that product is greater or less than it was before, then the "work" done is also correspondingly greater or less. If we increase the velocity or distance per second, then we can lessen the time or the weight, and *vice versa*.

SYSTEMS OF MEASUREMENT OF "WORK."

The foregoing is the "foot-pound second" or mechanical system of measurement. For many purposes the "foot-pound" unit of measurement is altogether too large for convenience. In watchmaking, for instance, it would be useless, also in most electrical work. Electricians have accordingly adopted the *centimeter*, the *gramme* and the *second* as their units of distance, weight and time, respectively, forming what is called the international "C. G. S." system of measurement, so called from the initial letters of the three units composing it. Still another system is based on the measurement of the heat of a body, and the amount of work done is found by comparing it with the amount of work required to raise 1 pound of water through 1 degree of temperature in 1 second of time. This we may call the thermal or "pound-degree-second" system.

THE HOROLOGICAL SYSTEM OF MEASUREMENT.

The units of the "C. G. S." system are still rather large for the watchmaker. The *centimeter* is about $\frac{1}{10}$ of an inch, and the *gramme* is equal to about $15\frac{1}{2}$ grains, Troy weight. But as they are French measures, not in common use in this country, and perhaps never will be, we will employ our English measures, the inch and grain, thus constituting an "I. G. S." system for horologists. For very fine measurements we can use a smaller unit than the inch. As a *millimeter* is a thousandth of a *meter*, we may use the term "mil-inch" for a thousandth of an inch, making a "M. G. S." system for fine work.

The "work" done would then be found by multiplying together the number of grains lifted, the number of mil-inches through which they were lifted per second, and the number of seconds (or parts of a second) of time during which this work continued at that rate. The watchmakers' unit of work, instead of being a "foot-pound,"

would then be the "inch-grain," and the power of a spring, for instance, would be the number of "inch-grains" of work done per second. The foot-pound unit is $12 \times 7,000 = 84,000$ times as large as the inch-grain, because there are 12 inches to the foot, and 7,000 grains to the pound Avoirdupois. And as the foot-pound per second is only $\frac{1}{84,000}$ th of a horse power, it will be seen that the inch-grain is a pretty small unit for mechanical work.

MEASUREMENT OF THE LOSS BY FRICTION AND HEATING.

In transmitting power through gearing, more or less of it is lost by friction and heating of the parts which rub together. When examined under the microscope, the smoothest surfaces we can produce are found to be very rough. In moving one over another the projections of one interlock with those of the other, some rub over each other, and others are torn off, producing an actual obstruction or resistance to motion. This resistance, if alone, could be measured. But with it there is always a production of *heat* by friction, which is usually conducted away by the air or surrounding objects, and so dissipated and lost.

But by proper means this heat can be prevented from escaping, and accurately measured. This is most conveniently done by causing two metal plates to rub together in a vessel of water, oil or mercury, and comparing the power expended in moving the plates with the increase of temperature produced in the water thereby. By suitable precautions and with due allowances, this shows the amount of mechanical energy or work which is the equivalent of a certain rise in the temperature of the water.

In this, and other ways, it has been found it requires 780.2 foot-pounds of work to raise the temperature of 1 pound of distilled water 1 degree Fahrenheit, and therefore 780.2 foot-pounds of work are termed the "thermal unit." Thus we find that mechanical energy and heat are mutually convertible, and the law is this: "Heat requires for its production, and produces by its disappearance, mechanical energy in the ratio of 780.2 foot-pounds for every thermal unit." When heat is produced by friction, therefore, a definite amount of work has been done in producing it, and that amount of the power of the machine has been wasted or lost.

In a similar way it has been found that an electric current of one ampère, having an electromotive force of one volt, *i. e.*, having a strength of one *watt*, as it is termed, is equal to one-seven hundred and forty-sixth part of a horse power, or we may say that one watt is equal to .7375 foot-pounds of work per second.

Without going into further details, it will suffice to say that the different forces or forms of energy are thus convertible into other forms in definite proportions. But as any such conversion of one form into other forms of energy is really so much power lost to us, because not available for the purposes of our mechanism, our present object is to study the mechanical laws governing the transmission of power, so that we may work in accordance therewith and experience the smallest possible amount of such losses.

(To be Continued.)

NEW ALUMINUM PROCESS.—The Maussier aluminum process is coming to the front in England, for it is announced that one of the largest engineering firms has undertaken to work it on an extensive scale. The process comprises three distinct periods and kinds of operations—the desilification, the reduction and the liquation. The desilification is effected by means of fluorine or fluoride of calcium at a high temperature in the presence of carbon. Lime, or the carbonates of potassium or sodium, may be added to facilitate the decomposition of the silicate. The reduction or expulsion of the oxygen is obtained by means of iron and manganese raised to incandescence in the presence of carbon. The liquation, the object of which is to separate the aluminum from the iron and the manganese, is effected by dropping the molten mass into carbon ingot molds. These molds are made of wood charcoal. The aluminum so obtained is nearly pure.



Proceedings of the Watchmakers' and Jewelers' Union.

Fourth Meeting.—Reported by the Secretary.

[NOTICE.—We shall be pleased to receive and discuss descriptions of new tools, attachments and improvements in any branch of our trade, and publish them free of charge; also inquiries from those desiring information on any point of general interest. Communications should be written as concisely as possible consistently with clearness, on only one side of the paper, and be received here by the 10th day of the month, in order to be discussed at our meeting for that month and inserted in the next issue of THE CIRCULAR. Address them to "Secretary of the W. & J. U., care of THE JEWELERS' CIRCULAR, 189 Broadway, New York." For full information for correspondents, see our Proceedings in THE CIRCULAR for October.]

HOME-MADE STAKING TOOL.

New Salem, S. C.

Secretary of the W. & J. U.:

Since the fraternity at large is requested to send to your body drawings and descriptions of such tools or devices as may have been gotten up by any member of the craft, I write merely to say that I have a riveting stake improvised from the brass part of a Jacot Lathe, which I consider as good as the best.

Any watchmaker having a lathe and is fond of turning, can easily make one, if he is not too lazy, and it will last a lifetime. There are 48 punches and sub-punches or stakes, all interchangeable and cannot be broken.

It does not injure the Jacot as a lathe in the least, as the original centers can be preserved.

I send you tintype picture of the tool. One end of the "plunger" is seen to be smaller than the other. The reason of that is, it was one of the original centers of the Jacot, and being too short for the present purpose, I drilled and put in a plug to lengthen it.

You can judge whether or not it will be of sufficient interest to illustrate and describe.

Respectfully,

W. F. M.

Mr. EXPERT said that a very excellent staking tool could undoubtedly be made as described by our correspondent. If the stakes and punches are well made and fitted, the tool itself is so true and accurate that the staking and riveting would be very perfect. For light work, and in the hands of a careful workman, such a staking tool could be used without endangering the perfection of the operation of the lathe, but he would hardly care to risk it for heavy work, or to be handled by many heavy-handed, rough and careless workmen he knew of. Its value as a Jacot lathe, which is nothing if not perfect, would soon disappear under their battering and twisting. As a matter of principle he did not approve of employing delicate tools like Jacot lathe, uprighting tool, depthing tool, and the like, for other than their normal purposes, especially when the new use was harder and rougher. It is seldom that a fine tool can be really perfect for more than one purpose, and when used for several, the combination tool is apt to gain in multiplicity of uses at the cost of a loss of perfection for each of the separate uses. But there are, of course, exceptions to this rule. And when a workman needs a certain tool, and time is more plentiful than cash, it is entirely proper to adapt some other tool for the needed employment, provided, of course, that it can be done and so used without injury to the original tool.

REPAIRING WATCHES "BY THE PIECE."

Secretary of the W. & J. U.:

At your last meeting, Mr. BENCHMAN said that he worked "by the piece" at watch repairing. I would like to have him explain how that is done, and think it would be of interest to a good many workmen besides.

Yours truly

"JOUR."

Mr. BENCHMAN then explained that it was a custom confined to very large shops having a great run of work. They did not pay any fixed wages, but employed men to do the work "on shares," so to speak. The terms of the bargain vary somewhat in different places,

but, in the shop where he was, the proprietors furnished shop, materials and conveniences, and the men furnished their own tools and did the work for one-half of the charges on the job.

But the peculiarity of the system is that the man who has worked longest for the house has charge of that department, and has his choice of the jobs that come in. The next oldest man gets the next chance, and so on to the last comer, who takes what is left by the rest—when there is anything left over.

A man applying for a situation in such a shop furnishes references and evidence that he is a good workman and trustworthy, and is then enrolled on the list of watchmakers. But he is candidly told that he may not get regular work for some time. Every time one of the other men leaves, he gets one peg higher on the list. Sickness among his seniors also gives him a better chance for the time being. If he sticks long enough he will finally get to be first man, which, in a large house, is a fat situation. But he may have a hard time of it while waiting, for he must hold himself in readiness to do any job he is called upon to execute, even if it should be only one job a week.

This plan has its advantages for both sides. It saves the house the expense of a corps of workmen when business is dull, but while it is brisk it does not make so much profit as by the other plan. And for the workman, it is a very desirable plan when he gets near the top, but if he is not skilful or does not get on well with the bosses, he will be weeded out long before he reaches that point. On the other hand, he does not lose his position if sick, for there are others glad to fill his place. And if he has business to do, he can attend to it at his pleasure (unless he does a special kind of work), and of course at his expense.

If a workman is a "special," more competent than the others to do a certain kind of work, he stands a good chance to get those jobs almost from the start, and in return is expected to hold himself always in readiness to take them. But few men like to be confined to one kind of work, but prefer to be "general men," and get a whack at everything that comes in.

For the average workman in the average shop, the wage system is undoubtedly preferable, for he gets a fixed sum, and knows what to depend upon each week. And when he can get as high as \$25 a week, most bosses would willingly swap profits with him.

From all of which we may draw the moral that it pays best to be a first-class workman, because he can make money almost anywhere and on any plan of working.

REPAIRING A DIAL POST.

Secretary of the W. & J. U.:

How can I splice the post of an enamel dial, which is broken off in the notch where the screw takes into it?

W. W. R.

MR. BLOW-PIPE did not advise splicing at all, but putting in a new post. First remove the old stump as low down as convenient, with sharp cutting pliers, being careful not to exert the slightest strain or twist on the post, but let go of the dial while cutting. The posts are riveted in the dial plate, and twisting will loosen them and scale off the enamel on the face of the dial.

Next file it down to the enamel with a sharp file and very light pressure, supporting the dial underneath on the tip of the finger. Then take a small emery grinder, made in either wheel or ball form, running in the lathe, and grind out a little hollow through the enamel, having the post as a center, and say $\frac{1}{8}$ to $\frac{3}{16}$ inch in diameter cutting away both the enamel and stump, and exposing a clean copper surface upon which to solder the new post.

The post is to be made with an enlargement or foot something like a dial screw. This foot may be a copper disk riveted upon the end of a wire of proper size for the post, but preferably by taking a wire large enough for the foot and turning down the body of the post to size. The foot is to be fitted into the hollow and be soldered there. Its thickness should be such as to rest upon the watch plate when the dial is down properly in its place. If found a little too

thick when soldered on, the excess can be dressed off with a "hollow drill," or cutter fitting around the post.

All being finished, ready for soldering, tin over the surfaces which are to be joined, on both the dial and foot. To tin the hollow, heat the dial very evenly and gradually till a little lump of soft solder will melt. Keep the copper from tarnishing by rubbing it with a bit of wood, like a match, wet with soldering fluid. When the solder melts rub it around till the whole surface is thinly covered with an adhering coat of solder. Do the same with the foot of the post, which is easily done by rubbing it over a flat piece of tin plate held in the lamp flame till a lump of solder on it melts and spreads, then rubbing the dial post upon it, and shaking off any surplus of solder. Such a plate of common tin, or several of different sizes, will be found more handy than a soldering iron or a naked flame, for most of the jewelry repairing jobs which require soft soldering. Use plenty of the soldering fluid, put on with a soft stick.

In soldering the post to the dial, different ways are followed. Some wrap the dial in several thicknesses of soft paper on the side most distant from the broken post, so that they can hold it without burning their fingers. They then wave the dial over the lamp flame, gradually bringing it closer, and finally passing it through the flame, from side to side, to avoid heating it too suddenly. The dial post wire is held in a pin vise in the other hand, and is also heated. When the dial is hot enough to melt solder, a small piece is placed in the hollow, with soldering fluid, the foot of the post put in position, gently pressed down, with a twist or two to insure close con-

justing the new post, as shown in fig. 4, which shows a portion of dial *D*, with scratches in line with the sides of the old post *p*. The small figure *p*, shows the general shape of the new post.

Mr. BLOW-PIPE hoped that these explanations would be full enough and clear enough to satisfy our young apprentice friend, W. W. R.

Mr BENCHMAN thought that in the case specified by our correspondent, where only a little of the post is gone, it would often be preferable to cut down into the old post, dovetail in a piece of wire of the same size, rivet a little, and also soft solder it in. Finish up the addition to suit. With good tools and some "gumption" a good job could be done in much less time than the fitting in of a new post, and be less risky, especially with dials having sunk seconds cemented in, as the heat need be applied only to the new part or wire.

In fig. 5, 1 is the piece to be inserted in the post, with the lower end of the tongue slightly enlarged; 2 shows it inserted in the post; 3 is a side view of 2, showing the notch in profile. The top of the old post is filed down to the dotted horizontal line 4, to strengthen the splice-piece and give it a stronger hold on the post. First solder the piece in, with just enough solder to fill in the joint thoroughly but have none outside, then lightly rivet or burnish down the edges of the tongue, lastly melt the solder again, adding a little more if necessary to fill out

A good way to saw into the post safely is to clamp it between two pieces of wood, whose inner faces are grooved a little to receive the post tightly, then saw down through both post and wood. In this way no strain comes on the dial or post, but all on the wood.

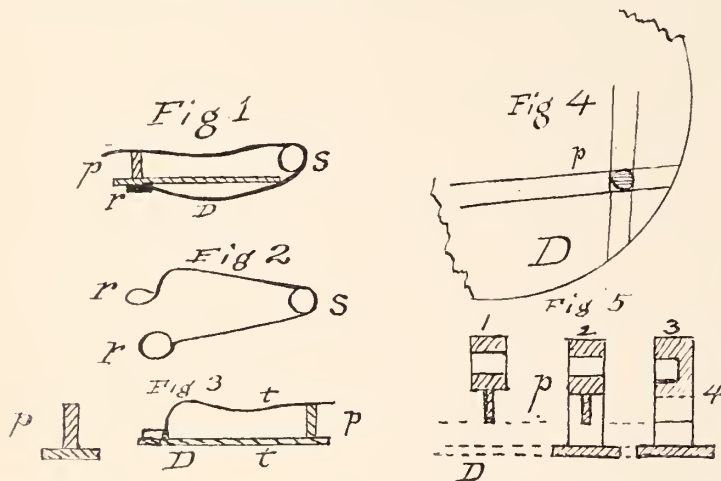

tact, and held so, upright and correct, till cool. Some workmen brace the fingers of the two hands together, to facilitate the keeping of their relative positions, and remove the dial from the flame for the cooling. Others rest the hands against some support, when the parts are properly together, then blow out the flame—while the hands remain as they are, till the solder sets.

Others make a light spring or wire clip, which fits over both dial and post, and clasps and presses them together. This holds the post in place during the heating and cooling. Still others lay the dial face down on a flat metal plate, which is slowly heated up, and the dial post applied, either by hand or by spring clips, as described. These clips are something like a safety pin, one-half resting against the face of the dial, while the other presses upon the end of the new post. Or it may have an eye or ring on the end, to fit around the post and press upon the foot, by its spring.

In fig. 1, *D* is the dial, *p* is the new post, *r* is the end of the clip, underneath the dial, *s* is the spring in the bend, and the other end presses on the top of post *p*. Fig. 2 shows the clip alone, the end *r* being spread out in a flat ring to prevent tipping and pulling the post over. Fig. 3 shows a plain wire clip, with one end spread, and the other resting on the post, the whole being held in the tweezers at the points *tt*.

To insure the post being in the proper position, many workmen take pains to mark the exact position of the original, by light scratches on the back of the dial, in two directions, as guides in ad-

THE BEST OIL FOR FRENCH CLOCKS.

Secretary of the W. & J. U.:

What is the best kind of oil to use on French clocks? One jobber wrote me clock oil, another said watch oil. I refer the question to you.

Respectfully,

E. K. B.

MR. DETENT said that as a rule clock oil should be used on clocks. If the oils are good, the difference between clock and watch oil is that the former has more body and will stay in its place under a heavy pressure where a thinner oil would be squeezed out. But as there are no very heavy pressures in the ordinary French clock, clock oil could be used on the heaviest bearings, and watch oil on the others. Or, if the clock was a fine one, and was expected to run a long time before being cleaned again, chronometer oil could be employed. But, as before stated, in the case of the ordinary French clocks, first-class clock oil is generally good enough.

MAKING EMERY CUTTERS.

Secretary of the W. & J. U.:

In a recent number of THE CIRCULAR there was mentioned an "emery cutter." What is that? I have never seen them in the stocks of the material men. I would like to know where to get them, or how to make them.

Philadelphia, Pa.

G. S. J.

MR. BENCHMAN said that the small emery cutters referred to were not on sale, but were generally made by the workman himself, to suit his needs. Take a little fine emery or corundum, such as is kept at the hardware and tool stores, warm it in a dish till gum shellac will melt when thrown on it, then add enough shellac to make a sort of putty by mixing with the emery. Do not heat enough to burn the shellac, but it must be fluid, and must be very thoroughly mixed with the emery. There should be enough of shellac to fill the interstices between the particles of emery, but no more. If there is too little shellac, the cutter will be fragile and crumbly; if too much, it will gum over when working and not cut so well. The proportions will, of course, depend on the coarseness of the emery. Doubly washed emery will do for all but very large cutters. Put in shellac till the mass looks solid but has none free on the surface.

While this putty is still hot and sticky, heat the metal piece which is to form the core or center of the cutter and rub it in the mixture till well smeared and covered with an adherent coat. Then put on

J. B. BOWDEN & CO., RING MAKERS,

Broadway and John Street, New York.

Entrances, 192 Broadway and 9 & 11 John Street.



AIKIN, LAMBERT & CO.



P. O. BOX 1155.

23 MAIDEN LANE, NEW YORK,

JAS. C. AIKIN.
H. A. LAMBERT.
JOHN B. SHEA.

Manufacture

(GOLD PENS, HOLDERS, PENCILS, TOOTHPICKS,
Glove Buttoners, Match Boxes, Novelties,
PAUL E. WIRT AND OTHER FOUNTAIN PENS.



NEW DESIGNS

ARE CONTINUALLY BEING PRODUCED IN
Oxydized and Bright Work in Silver, Pearl,
Celluloid, Roll Plate and Solid Gold.



The attention of responsible buyers is invited to **Special Bargains** in our line of **Swiss Watches**, Discontinued American **Movements and Cases**. **Diamonds and Jewelry**. Goods made to order in our own Factory.

Do not replenish your stock before seeing our goods.

ORDERS PROMPTLY FILLED. AMERICAN MOVEMENTS WITH OR WITHOUT CASES.

CHAS. S. CROSSMAN & CO., MAKERS OF THE ONLY OFFICIAL INTERNATIONAL Y. M. C. A. BADGE.

DESIGNED IN GENEVA,

ADOPTED IN LONDON,

ENDORSED IN AMERICA.

AGENTS WANTED. PRICE LIST AND DISCOUNTS ON APPLICATION.

23 MAIDEN LANE, NEW YORK.



enough of the compound to form the cutter, shape it as you want it, and let it cool.

The shape and material of these cores will depend on circumstances. If the cutter is to be rotated by the fingers a piece of pegwood will serve for both core and handle. If to be used in a live spindle lathe, the core should be metal, and the shank should be round and true to fit the lathe chuck, but the part receiving the emery mass should be left rough, to secure adhesion.

Mould the mass into approximate shape with a cold knife blade or finishing file, or even with the fingers. While still soft enough to be moulded, the mass should be rolled into some symmetrical shape for use, such as a cone or ball, or it should be pressed between cold, flat, polished surfaces if it is to be straight or tapering, square or rectangular. Moisten them, if the mass sticks. Do not press too hard, or the cutter will not be sound and solid. A little experience and care will teach what is required.

The speaker then showed a drawing (as in the accompanying cut) of a few of the shapes that could be made: 1 is ball-shaped or round, the unshaded part being the pegwood core and handle. 2 has a flat end. 3 is a smaller one, with rounded end and tapering body, on a metal core, to be run in a lathe. 4 is a cone-shaped cutter, suitable for opening the holes in watch dials, etc. In using it the speed should be slow and the pressure light. Cut the enamel to the copper, then reverse the dial and cut the other side the same way, then reverse again. The cutter should not touch all around the hole, as it is liable to stick and *screw in*, which would crack the enamel off. Let it touch only one side at a time, and so go around the hole.

As these cutters are cheap, a great variety of sizes and shapes can

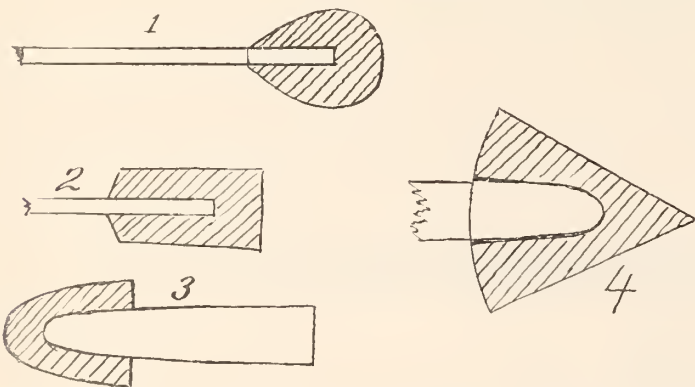

be made, to suit all cases. They should be used with light pressure, and kept wet with water (not oil) to keep them cool and remove the *débris* of the work. When worn they can be reformed by heating and moulding as before.

Mr. UHRMACHER said he had used, instead of the shellac, which was somewhat brittle, a compound called Spence metal, a sulphur-sulphide, made by dissolving sulphide of iron in melted sulphur. This metal fuses at about 400° Fahrenheit, is hard and strong, and does not gum over like shellac. It can be used for large as well as small cutters, from the fine pointed cones up to bench files and small grindstones.

In making cutters with it, about the same precautions as mentioned by Mr. BENCHMAN should be taken with this material, to avoid overheating, etc. But this mixture (Spence metal and emery) should be gently tamped or patted down in a mold of proper form, as it cannot be pressed into shape so easily as shellac. In reforming worn-out cutters made of it, they should be heated up very slowly, to avoid burning out the sulphur and making it weaker or rotten. Spence metal is for sale by metal dealers in New York, and perhaps in other large cities, but is not an article generally kept. In small quantities it would probably cost about fifty cents per pound.

"WHAT MAKES THESE WATCHES STOP?"

Secretary of the W. & J. U.:

In regard to troublesome watches, referred to by W. S. M., I beg to state that I have had some of the same kind. Sometimes I'd come to the conclusion that they

were bewitched, or had a little devil in them—a sort of judgment sent on me for overcharging some poor fellow on a soft job. But on careful examination, nine times out of ten, I found a loose or shaky jewel pin or pallet "stone," and occasionally the hair spring collet a bit too loose and would slip just enough to throw the balance wheel out of poise.

Respectfully,
Junction City, Texas.

N. C. P.

MR. EXAMINER responded that our correspondent had pointed out several defects which were fruitful causes of trouble to watch repairers. When the ruby pin or pallet jewels are loose, it is generally owing to the use of alcohol in cleaning. These jewels are cemented in with shellac, which is readily dissolved by alcohol. The result of cleaning those parts with alcohol is therefore the removal of the cement which holds the jewels in place. A little of it may be left, enough to prevent the workman from noticing any looseness or weakness while working at the watch, but under the strain and blows received in the running they may be torn loose, or moved out of position far enough to make trouble. These jewels should always be examined and felt of very carefully, to see that they not only are not loose, but have plenty of cement to hold them. Parts cemented with shellac should not be cleaned with alcohol, but benzine or ether should be employed, if any solvent for grease is required, more than the old-fashioned chalk brush and moisture from the breath.

Another frequent cause of trouble is a loose hole-jewel. In setting these jewels, the sockets are frequently cut out larger than the jewels meant to go in them. Then the bezel is burnished down over the jewel, and for the time being, the jewel is tight. But it is held only by the pressure of the brass on its surface; all around its rim there is a space between it and the brass, leaving its edges unsupported. A hard jar may move this jewel sideways, or a heavy strain, like that on the third wheel jewel, may do the same, and the watch will lose its free motion or stop.

Even when the surface of the jewel is beveled too steeply to permit any such movement as just described, such a jewel will sooner or later be loosened in another way. Brass expands and contracts more under changes of temperature than jewels. In cold the bezel contracts more than the jewel, and the jewel being too hard to yield, the bezel is bent or raised to that amount. Then when the watch gets warm, the brass expands more than the jewel, the bezel is raised out of contact, and lo, the jewel is loose—being now held neither on its surface nor around its edges. When the jewel is well fitted in its bezel, this difference of expansion, being but slight, will require a long time to perceptibly loosen the jewel. But when the jewel is too small for its bezel, and becomes loose as described, any side pressure will move it to one side. In that position it may be tight again, but the next cold contracts the bezel, and soon the jewel will be so loose that it can be shoved around in any direction.

Hole jewels should be carefully felt of, under the eyeglass, to see if there is any shake, either sideways or up and down. In burnishing the bezel to tighten a jewel, first burnish around the edges till the brass meets the jewel, then burnish the bezel over its face.

When hole jewels are set in brass, the settings may be too small for their seats, and be held only by the pressure of screw heads or set cap jewel upon their surface. All such should be tightened so that they fit snugly in place, even before the screws or caps are put in.

Another prolific cause of trouble is a loose cap jewel over the balance pivot. It will seem tight and all right when the watch is first put together, but soon gets displaced a little to one side, turns up a little inclined to the end of the pivot, pressing it to one side of the hole, and perhaps pinching it so much as to check the motion, or it may let the pivot through the hole so far that the shoulder rubs. Cap jewels should always be tight enough to insure that they cannot turn up inclined, nor let the pivot through the hole jewel more than the normal amount, *i. e.*, they must stay practically just as they are placed at first. If they are foot jewels, or caps for the lower pivots, they should either be set in the cap or cemented there. If on the outside, or top, and cannot be kept tight in any other way, they had better be cemented there, also, doing it so that the cement is not visible outside.

Some of these faults were not suggested by Mr. P., but attention is called to them because they may frequently be the cause of the difficulty complained of by Mr. W. S. M.

As the hour was growing late it was moved to adjourn, and the many interesting subjects still undiscussed were carried over until the next meeting.



A CLOCK BURIED IN ICE.—On the desk of Edson B. Bruce, chief clerk of the bureau of equipment and recruiting in the United States Navy Department, is a little rosewood case, bound and inlaid with brass and bronze. It is in the form of a cube, about eighteen inches high, and contains a chronometer such as is used on all naval vessels. This little instrument has quite a tragic history and is held in considerable value. It was the ship's chronometer of the unfortunate *Polaris* that was sent out on an Arctic expedition by the Navy Department in 1871. When the *Polaris* was nipped in the ice, Captain Hall saved this instrument among other things from the vessel. As long as Captain Hall survived, he kept the chronometer with him. When he perished, it was buried in the arctic snows and abandoned. This was some time in 1872. For four winters it lay buried there, until 1876, Captain Nares of the British navy, then in command of the last expedition to the arctic region, discovered it at Newman's Bay. He dug it out of the snow and took it to England. It was found to be in perfect order. Captain Nares turned the instrument over to the British admiralty office, whence it was sent as a present to this government. With all this experience, it loses only a single second in twenty-four hours.

GOLD MINES OF SOUTH AFRICA.—The gold mines of South Africa, which are now in the full swing of their development, are gradually attracting the notice of financiers and speculators in all parts of Europe. With only a few properties working the last month, the production was over 35,000 ounces of gold. There have been great drawbacks to the speedy development of the mines, not the least being the difficulty of transportation and the expense of fuel and labor. Every piece of machinery has to be conveyed over the worst roads in the world, for more than 300 miles, by the slow bullock wagons, but railways will soon be constructed to the fields, and then better things may be expected.

CURIOUS TIMEKEEPER.—A curious timekeeper, used in the outlying parts of southern India, has been presented to the British Horological Institute, by R. G. Orr, of Madras. It is a thin metal bowl rather deeper than half a sphere, with a very small hole in the bottom. When the flight of time has to be noted the bowl is placed in a bucket of water, and a boy sits watching it till, in about forty-five minutes, the bowl fills and sinks. Clearly the people in southern India do not trouble themselves about fortieths of a second, though a gentleman who has tried it says it is tolerably accurate, but the time of filling varies somewhat with the temperature of the water.

PENDULUM.—Able minds were formerly constantly at work in trying to observe, improve, and modify the pendulum, and it is indeed a well-founded cause of reproach that we of the modern school do so little in this direction. We are too much disposed to unquestioningly take the pendulum as it is, without ever trying to inquire into the why's and wherefore's. In 1855, Merceron showed, at the Paris Exhibition, a pendulum in which the effect of temperature was avoided by forming the rod of a series of bi-metallic strips arranged alternately, and Ingold proposed methods for carrying out this principle; modifications were also suggested by Saunier. It is only necessary to point out that the brass is on an equal number of concave and convex sides, and thus, the position of the bob, which is supported at its center, remains unchanged, since one bend will tend to close to the same distance as the next one to open. Another application was proposed by an Astronomer Royal of England, for effecting the final adjustment of the compensation, and adapted in the Greenwich sidereal clock. Two small, straight, bi-metallic arms, carrying weights, are held friction-tight on the crutch axis, and, by varying their inclination, it is possible to alter the vertical distance through which their common center is moved on a change of temperature. This motion is anticipated to produce the requisite

change in the rate of the clock, but it has not yet been found necessary to bring it into action.

REMARKABLE PERFECTION OF THE MICROSCOPE.—The Optical Institute of W. & H. Seibert, of Wetzlar, Germany, the productions of which caused general admiration in the Exposition of the Heidelberg Congress of Natural Philosophers, has succeeded in devising a most wonderful improvement of the microscope. This new apparatus has shown the interior construction of the bacillæ of kidney disease, the existence of which no one has hitherto suspected. This bacilla has been regarded as a single rod without special marks, but with the new microscope it appears as consisting of a series of small nodules strung together like beads on a thread, etc. The microscope is constructed of apochromatic lenses, and with it the object can be magnified up to 2,250 times its diameter.

HONORS.—The Bavarian Academy of Sciences has caused new memorial coins to be struck, which are to be divided among those scientists who have sent to it either meritorious scientific dissertations or contributions to the State museums. The obverse of the coin contains the head of Athene with the inscription "Academèa litterarum et scientiarum regia boica bene merenti." The reverse contains the motto of the Institute, "Rerum cognoscere causas." The first two silver coins have been sent to Karl A. Neeser, of Copenhagen, and Dr. Deye, of Java. Gold and bronze coins have also been struck.

GOLD CANNON.—A large cannon is to be seen in the Tower of London, which is cast from gold and other precious metals. It is said that \$100,000 has been offered for it; twelve inches were once cut off and sent to Birmingham for assay, from which a value of £8,000 was obtained. The inscription on the cannon says that it was cast by Mohammed, son of Hamzel Allah, at the command of Sultan Soliman, son of Selim, for a descent into India, in the year 937 of the Hegria (A. D. 1530), and at the conquest of Aden, Jan. 1839, by the expedition under the command of Capt. H. Smith, of the royal ship *Voyages*, it fell as booty of war into the hands of the English.

ANNIVERSARY.—Bachni & Co., manufacturers of balance springs, Bienne, Switzerland, recently celebrated the twenty-fifth anniversary of the foundation of their factory. The firm published a little pamphlet, with statistical tables showing the progress of the concern. In 1863 the firm commenced work with one workman, and very imperfect utensils; to-day it employs sixty persons, and the principal utensils consist of five rolling machines and twenty-five drawbacks, all being actuated by a twelve horse-power steam engine. As for the small tools used, there is an endless variety necessary for treating the balance spring in its twelve different stages, before it is ready for the market. The factory has a capacity for manufacturing 500,000 dozens of springs per year. Since its foundation, the establishment has produced 52,000,000 balance springs, representing a length of 16,000 kilometers (10,000 miles) and a weight of 10,000 kilograms (22,046 lbs.) of steel. At the present price of springs, one kilogram (2 lbs. 3¼ ozs.) of steel is worth 600,000 francs. There is probably not another metal fashioned into articles of industry, which attains to such a value, as compared to that of the crude material, as steel. Thus, the spring for a four-line watch, the weight of which can only be ascertained by an apothecary's balance, is worth at least 100 francs.

INVENTOR OF THE THIMBLE.—There is a rich family of the name of Lofting in England, the fortune of whose house was founded by such an apparently insignificant thing as a thimble. The first ever seen in England was made in London, less than two hundred years ago by a metal worker named John Lofting. The usefulness of the article commended it at once to all who used the needle, and Lofting acquired a large fortune. The implement was then called the thumb bell, it being worn on the thumb when in use, and its shape suggesting the rest of the name. This clumsy mode of utilizing it was soon changed, however, but the name, softened into "thimble," still remains.



[FROM OUR SPECIAL CORRESPONDENT.]

A DISSERTATION ON STYLE.—EIGHTEENTH CENTURY DESIGNS.—
ODDITIES IN DIAMOND WORK.

PARIS, DEC. 10, 1889.

All manufacturers in our lines are well occupied; yet very few of them seem to have more orders than they can easily manage. Some complain as usual that business is bad; but as those will, no doubt, think exactly the same next year, whatever may be the general opinion, their statements are of no importance. Evidently it cannot be expected that all manufacturing places ought to be equally fortunate. Some make pretty patterns, and find out the best way to call attention to them. Others give themselves no end of trouble to imagine an original design, and fail to obtain the approval of the public. Besides, a model must come *à propos*. If you bring out an elaborate pattern, when there is a general longing for something simple, whatever taste and talent you may have spent over it, your model will not sell. Yet, if it be really artistic, it might take later on, when the fashion has altered. The safest plan is not to be exclusively partial to any style. I know several Parisian silversmiths who have been established many years, and whose business has always been very flourishing. I think that the principal reason of it is that they have a great variety of patterns, especially of a middle-class character. In the spoon and fork line, I have seen, at their places, the most different models, all of which, from the oldest to the newest, seem to be equally successful. The fashion for historical styles, Louis Quinze and others, is not so thoroughly overruling in France, as it might be inferred from the majority of silverware exhibited this year at the Champ de Mars. There was no French spoon and fork manufacturer of importance, in the silver line, among the exhibitors, and I really think it was a great pity. To see a large display of varied but sober patterns of spoons and forks, with no pretence to a high sounding name, would have been for us quite a relief. The general effort to show something artistic was too visible, and although visitors thought they must admire, the accumulation of overwrought pieces was, I believe, almost painful to their eyes. The class 24 seemed to contain nothing but collections more or less important of well repaired old pieces in silver, showing on the part of their owners a decided preference for the Louis Quinze style. Although it is well known that the rococo has been the rage for a long time and still is very fashionable in the hollow ware line, yet a notable portion of our middle-class people have resisted the craze. Sensible manufacturers, who thoroughly understood it, have made several patterns of a quiet and unpretending style for that kind of purchasers not to be neglected; and retailers who want to miss no chance of doing business admit those models among their display. A small spray of flowers half curling round the base of a spoon handle, and shooting up gracefully on one side, does not look, after all, so very commonplace, and if designed and executed by an artist, can suit to a nicety persons of a sober taste. Other patterns of the same kind are obtained with an ornamental foliage which, bordering the base, appears again half way up the handle, and also adorns the top, near the prongs of the fork, or the back of the spoon.

Among the large pieces covered with ornaments, belonging to the eighteenth century, we welcome here and there, in some of the best places, a very simple pattern. The vase reproduced here is a fair specimen of that class of goods. In the shape of a crater, with rather light handles, which are plain yet elegantly curved, it is adorned with sprigs of berries gracefully arranged. The ornaments running along the top are of a very sober style. Such vases are generally given as prizes at flower or fruit exhibitions. Those awarded at cattle shows are often adorned with fine portraits of

cows and other familiar animals. The work is done in repoussé.

Jewel caskets in silver are always made in a very elegant style, as they admit to an unlimited extent the introduction of figures and ornaments, either cast, chased and applied on the casket, or embossed in various reliefs; artists in metal delight in that work. When they are asked to adorn a piece of that kind, they often unrein their fancy most unreservedly. Odist's casket in renaissance style surrounded with figures illustrative of the seven sins, is certainly a



XVIIIth CENTURY SILVER VASE.

striking specimen of that kind. I must say that it is thoroughly artistic, the whole of it being well proportioned and beautifully finished. Yet the composition seems almost too elaborate for a piece of that size. Besides there is in it (although in a mild way) an evident effort at something realistic, which we have not been accustomed to meet with in silver. Very different in style is the casket reproduced here. It may not be quite so original as the other, but the ensemble as well as the details give a pleasing impression. The group on the cover is, so to speak, a sculptural transcription of Guido Reni's



ODIST'S JEWEL CASKET.

painting, *l'enlèvement de Déjanire*, which belongs to the Louvre. It is a faithful copy of that beautiful composition, and the outlines of the casket seem well calculated to set off that crowning piece. The ornamental head above the rather plain escutcheon has a fine effect, with the delicate arrangement of all its surroundings. The leonine chimeras placed on each side, to protect the jewels against any attack, look extremely precious. Yet they are very decorative. The two allegorical figures of Truth and Force are well

modelled, and the two cupids, at the base, blowing the trumpets, to glorify the fair owner of the casket and its contents, are full of life and energy.

In the jewelry line, a very original idea has led to creating some lovely pieces. I mean the use of net work in platina. It may serve, like a kind of tulle or lace to trim ball or soirée dresses. It may be crossed like a fichu, or twisted into a bow-knot; with a bordering of diamond embroidery work, it looks very handsome, especially if delicate sprays of diamond flowers are strewn across the fine trellis. A tiny insect made of well contrasted colored gems, appearing here and there, greatly enhances the effect. The net work in platina can also find place in the trimming of a handsome bonnet, and even be used alone, arranged in the shape of a lovely little cap. It might no doubt be turned into sleeves, and charmingly accompany a well formed arm. In fact it could be applied in many other ways, which intelligent jewelers must easily find out, when it is to their interest to do so.

A long established place in the Avenue de l'Opera has quite a specialty for sphinxes, chimeras, and other classical monsters, made of diamonds, rubies, sapphires, pearls, etc. Evidently the customers of this house must have a peculiar fondness for those strange looking jewels (not to say more), otherwise they would have been replaced many months ago in that shop's display by pieces of a different style. Another jeweler reproduces with diamonds the most elaborate designs in lace work, the whole being fixed on a black velvet ribbon, to be used either as a carcau necklace, or as a bracelet. It is very pretty when you look into it, but it would give us sufficient effect in a ball room or at the opera. The same can be said of some bracelets in massive gold, on which pretty scenes are delicately chased. They are considered as true masterpieces in their line, and, yet if you look at them from no very great distance, they appear like heavy bands of dead gold, clumsily embossed. These might be called private jewels, meant to give a kind of selfish pleasure to their owner; but they ought never to be worn at a public place, since nobody but the wearer can form any idea of their artistic value.

A small book, called *Les orfèvres Dijonnais*, has just been published in the old French town which, a little more than four centuries ago, was the capital of the Duchy of Burgundy. The author, Mr. Clement Janin, gives us a few interesting details about the old Dijon's goldsmiths. I only regret that he should have felt obliged to reproduce, at full length, the numerous anecdotes on Charles-the-Bold's diamonds, which all treatises on jewelry, French or foreign, have republished, with various alterations, during the last thirty years or more.

JASEUR.

A GIANT TIMEPIECE—Philadelphia will not be at a loss to learn the time of day or night after the big clock that is to ornament the tower of the public building is put into position. A person can form some idea of its immensity when experienced clock-makers say that it will take a whole calendar year to place the clock machinery in the tower after the building shall have been completed. The bell is to weigh between 20,000 and 25,000 pounds, second in weight to the great Montreal Cathedral bell, which weighs 28,000 pounds, and it is calculated that its pealings will be heard even to the most distant part of the city. The famed Westminster chimes will be used, ringing on the quarter, half, three-quarters and hour. The center of the dial (twenty-five feet in diameter) will be 35 feet above the street. In order to distinguish the time at night the dial will be illuminated by electricity, so that the position of the hands can be located from any point in the city. The minute hand is to be twelve feet and the hour hand nine feet in length, while the Roman figures on the dial will measure two feet eight inches in length. A steam engine will be placed in the tower to wind up the giant time-piece each day. All in all, it will be an immense affair, and a fitting emblem to the giant building now in course of erection.

Carving in Ivory.

The accompanying illustration is a very striking example of a class of work which is attracting much attention in Paris to-day. It is a bust carved in ivory and ornamented with silver, gold and precious stones. It is very difficult of execution, calling forth the highest powers of the sculptor and the goldsmith. The illustration which we herewith present to our readers is a bust, called *Gallia*, an allegory of France. It is in ivory, dressed in gold and oxidized silver, with here and there a precious stone; a pink topaz at the top of the corslet, a jargon on each side of it, and peridots forming the eyes of the monsters masks on the shoulders and the helmet. The chasing of the Medus, a head on the corslet and that of the chimera on the helmet, as well as the perfection of the repoussé parts are greatly to be admired. Although the effect



resulting from the ensemble of this work, enhanced by the contrast between the realistic oxidized silver coat of mail and the dead gold of the other parts is highly satisfactory, yet we must confess our decided preference for the ivory figure itself. Here is a lesson given to us by an art which ought not to be superior to ours. We are taught how to obtain an original expression, even in dealing with allegory. This personification of France is truly the portrait of a French woman; but of one thoughtful, intent and determined. There is nothing forced, nothing exaggerated in the rendering of the artist's intention. We see in these features an energy mingled with anxiety which is true to life. We have here no blank countenance in the Greek or Roman style, but that of a woman belonging to a French active class, with no pretence to beauty, at least of a conventional cast. This work does the greatest credit to the sculptor, Moreaux-Vauthier, who has devoted much time to the perfection of this difficult class of work and is a master at it.

Fashions in Jewelry

A Lady's Rambles Among the Jewelers and Dealers in Art Glass, Keramics and Bric-à-Brac.

ELEGANCE has given place to becomingness in necklaces, which are worn chiefly by young girls. The chains are slender, being often scarcely more than a thread of gold, from which hang five or more graduated pendants of precious stones. Sometimes they are set as a trefoil, the stones being ruby, diamond and sapphire. One beautiful style has three small diamonds from which is swung a pear-shaped moonstone. Graduated pearls are clustered in the same way. A pretty pattern has five white enameled pansies with diamond centers.

* * * * *

A NECKLACE for a debutante is made of small, white, open-petaled roses with a diamond center, and is clasped in a small spray of roses.

* * * * *

MOONSTONES, believed to be lucky, are far and away the favorite stone of the hour. They take carving handsomely. Two designs of brooches are believed to be doubly lucky. One represents the man in the moon's face in profile set in a diamond crescent, while the other is his jolly round face set in a halo of small diamonds. Heart-shaped moonstones are also believed to be of good omen in love affairs. Bracelets have heart-shaped moonstones, double and single, set round with diamonds and surmounted by love knots in diamonds.

* * * * *

PRETTY harp-shaped brooches seen have a mermaid as the upright, the head and body of the figure being cut out of moonstone and the tail-like appendage set in diamonds. Diamonds closely set form the rest of the frame, which represents one half of an anchor caught in the folds of the tail.

* * * * *

THREE lovely little cherub heads of moonstone with gold flattened wings are set on a curved bar and form a lace pin.

* * * * *

A PAIR of bonnet pins has a woman's helmeted head cut in moonstone. The helmet and the ruff about the neck are in diamonds. These form the head of each pin.

* * * * *

BEES, butterflies, beetles, dragon flies and plain flies (*musca*) are all considered worthy of imitation in moonstone and diamonds. The butterflies are varied, rubies and sapphires forming spots of color in the body of moonstone. They are often mounted in silver.

* * * * *

IN THE demand for moonstones, the cat's-eye has almost disappeared, but it is still used, though rarely found in the bodies of winged creatures with jeweled wings.

* * * * *

MEDUSA and Apollo, mythological personages of very opposite tastes and habits, are suggested in many and similar ways in the season's jewelry. This is conspicuous in the various rayed forms which meet the eye at every turn. Occasionally there is no confusion as to the motive. The sun god appears in a brooch with diamond eyes, nose and mouth—really a most suggestively jolly countenance. Two rows of waving rayed forms in tinted gold surround the face. In other rayed jewelry a large pearl is in the center of the rays. At the tip of one ray is another pearl, and midway on the alternate tips sparkles a diamond. This is one of the most graceful designs of the season. The same design is seen in colored stones.

Variations of this design in enamels and metallic tints suggest also the sunflower and the chrysanthemum. The Medusa is more often emphasized on liquor flasks. The face is that of a very pretty woman

* * * * *

JEWELLED sleeve buttons are double, but one side is a simple bar. The other side is an oblong design of gold wire set with jewels. In the center is a ruby very much in relief; around it are diamonds in a floral arrangement but sunk below the plane of the ruby. The sides are straight bars of alternating rubies and sapphires.

* * * * *

A JEWEL of a watch has a large diamond in the center surrounded by pearls thickly set in rayed forms and almost covering the sides. The outer edge is of deep red enamel.

* * * * *

THE rage for antiques has brought out many historic and antique trinkets from cabinets into common use. These have been also copied in modern work. Enameled pieces set in jewels or surrounded by chiseled gold in fine old designs are worth study, and give evidence of a taste for objects of art. Others are composed entirely of diamonds and are a brilliant addition to demi-toilet. Watches attached to these are jewels in themselves. The most striking are jeweled and enameled. Radiating forms, the trefoil and the fleur-de-lis are the favorite designs.

* * * * *

WATCHES set in bracelets are worn by every woman who can acquire them. They are intended for shopping. Formerly they came mounted in leather bracelets that buckled around the wrist. But these were rather cumbersome. They are now to be found in both silver and gold bracelets of light and attractive forms, and on bracelets of the latest fashion. Such an one is a heavy link bracelet with an open-faced watch surrounded by diamonds. On others, diamonds and other gems are even more lavishly used. In some bracelets the watch is detachable.

* * * * *

IT is told in one of the English papers that a woman who had so many diamonds she hardly knew what to do with them had her unset stones fastened to the stitching of her evening gloves. The result of her ingenuity is that jeweled gloves may now be bought in the London shops. It seems that they are set in gold and follow the three lines of stitching on the back, and are so set that they may be transferred from one glove to another. The cost of a pair of these jeweled gloves is forty guineas.

* * * * *

THOUGH diamond crescents are out of fashion, a pretty novelty consists of a very slender crescent from which hangs jeweled stars of rubies, sapphires and diamonds on long slender threads of gold. The effect is that of shooting stars and is very attractive.

* * * * *

FOR young girls are strands of tiny pearls with a single clasp. Small pale pink coral beads are worn in the same way and by the same class.

* * * * *

DARK hued pearls are much sought after by people of subdued tastes. A handsome ring is a circlet of dead gold with five large dark pearls.

* * * * *

SIMPLE rings for young girls are formed of triple rows uniting in a single band at the back. Turquoises, pearls and pale pink coral are thus brought together.

* * * * *

A CLOVER leaf brooch was seen in which emeralds are treated in a novel way. Three emeralds are set in the leaves and are covered with gold tracery, which imitates the veining of the model. Sprink-

led among the tracery are small rubies. The stem is of fine diamonds.

* * * * *

EMERALDS and pearls are among the new combinations of jewels. A magnificent pearl necklace is clasped by three fine emeralds.

* * * * *

A MOST dainty ornament is a spray of maiden's hair fern brought out in small diamonds. The fine flexible workmanship shown in the gold in which such pieces are mounted is worthy of comment.

* * * * *

GARTER clasps are prettily made of dead gold with an edge turned over and fastened down with a diamond, ruby or sapphire. Others are of Florentine design and sprinkled with diamonds.

* * * * *

IN PARIS the garter has become such an object of luxury that cases for them appointed in tortoise shell, ebony, fragrant woods and satin are made for the dressing tables as they are for bracelets and other jewelry.

* * * * *

PINS, combs and decorations for the hair increase in popularity. The combs which are intended to keep the tiny bonnets well poised are very narrow and are rather high. The perforated shell combs are often sprinkled with diamonds, and those with gold tops are interspersed with diamonds and other precious stones. A new design is to simulate gold lace in point or point applique and pick out portions of the design in brilliants. In some cases the lace is puckered, again it represents a bow or a rosette.

* * * * *

COMBS with enamel tops display the most lavish floral ornamentation, in which the leaves and blossoms are repeated in natural colors. By an ingenious operation the fusing of the enamels leaves them still transparent.

* * * * *

DEBUTANTES wear hairpins of enameled flowers which have either gold or jeweled centers. Daisies, pansies and wild roses are considered appropriate flowers.

* * * * *

THESE clasps are also used by young girls for the peculiar mode of dressing the hair low. These slides are covered with gold filigree, enameled designs, or are set with small stones such as turquoise, uncut sapphires and garnets.

* * * * *

ANTIQUÉ hairpins consisting of carelessly twisted gold wires and with knotted and interlaced tops are scattered through the hair.

* * * * *

THE Directoire costume has brought about in its revival many classic fashions. One of these is seen in the gold and silver fillets used for dressing the hair. These are thin and pliable so that they may bend to the head and hook easily at the back. When ornamented, the design is copied from antiques. The Greek fret is naturally most frequently seen. These fillets come in groups of three, and a fourth sometimes clasps the knot at the back. In some modes of dressing the hair a single fillet is used. This is heavier and wider, especially at the center, from which it tapers toward the back, and is much more richly ornamented.

* * * * *

ONE of the richest objects seen is a dead beaten gold parasol handle. It assumes a sort of rustic shape with gold vines in relief, of which the flowers are uncut sapphires, blue and white.

* * * * *

THE prettiest ornament for the amber lorgnons is made up of slender gold zig-zags and tiny gold nails set in stars, disks, circles and whirls.

* * * * *

IMAGINE a purse of fine gold network. This is hung on two gold

bars which are tipped with large pearls outside of circles of small diamonds. The purse is closed by a large ring set with diamonds. So exquisite is the workmanship, that the network is as flexible as silk. Smaller gold net purses are intended for gold coin and are without jewels.

* * * * *

QUAINT purses are of old-fashioned pale blue and pink brocades, sewn with pearls and mounted in gold. Other purses are of brocade with gold mounts and without pearls.

* * * * *

CARD cases and purses of leather are only less sumptuous than those of metal. A card case of black levant for sample is ornamented with fleurs-de-lis in diamonds.

* * * * *

TETE-A-TETE sets, with mountings of colored woods, ormolu and satin, are works of art and consist of two cups and saucers of Vienna porcelain in crimson and gold and small silver repoussé coffee pots, sugar and creamer.

* * * * *

FRUIT sets in cases are of silver gilt with perforated basket-woven edges and have different fruits engraved in low relief in the centers.

* * * * *

FULL description of all the fancy candlesticks that the Christmas holidays have brought out, would fill these pages. Some of the designs are quite amusing. One represents a modern Atlas in clown's dress lying on his back, his feet in the air, holding aloft a brass globe in which the candle is placed. The little figure is of silver. Another design is an athlete balancing on his chin the framework which sustains the candle.

* * * * *

CHATELAINES of old Dutch silver or in old Dutch designs are preferred for their rich effect. Celtic interlacings make lighter and more graceful chatelaines.

* * * * *

"THE Finger Bible," which the Oxford University Press has just brought out, will doubtless soon be brought over. This Bible is so mounted that it can be worn on the chatelaine. It is 3½ x 1 inch in dimensions and weighs only ¾ of an ounce; yet it contains the whole Bible and is the smallest book ever printed.

* * * * *

ENTIRE mirror and picture frames are made in white metal and britannia ware.

* * * * *

TRIPLE toilet mirrors are handsomely mounted in britannia ware. In many, Egyptian designs prevail, others are in "all over" floral designs thrown into relief by an etched background. These are most tasteful.

* * * * *

BROOM brushes are mounted in silver, white and britannia metal. The mounting is either repoussé or etched with but slight relief. These last are more suitable as they do not catch on foreign substances and are easier kept clean.

* * * * *

TRAVELING soap receptacles are made attractive as well as convenient in britannia by etching and chasing.

* * * * *

SOAP boxes of sterling silver are round in shape and are copied from antique styles. The base is chased in dogtrots and other conventional borders. The body is plain, and the richly carved and beaten top furnishes the rest of the ornaments. Silver puff boxes follow the same styles, the insides being gilt.

* * * * *

TABLETS are inserted between sterling silver covers. These are

shaped like handbags and hang from a ring. The cases are ornamented with raised silver bars, highly polished, with rich Italian ornamentation between the bars.

* * * * *

THE STERLING silver chatelaines are works of art, inasmuch as they repeat the beautiful foliations, mythological figures, amorini masks, grotesques and chimeras that distinguished the fertile fancy of the fifteenth century. A silver needle case swung on silver chains copies a bit of border from around one of the frescoes of Raphael in the Vatican. A pair of silver mounted scissors are hung in a shield-shaped case that copies a piece of Cellini. A pin cushion swung from the girdle is enclosed between two pieces of perforated silver repoussé work and elaborately chased which represents Jupiter despatching Mercury to conduct Priam to the tent of Achilles. On some of the sterling silver chatelaines which are made in three compartments one might almost read the history of the Trojan war.

* * * * *

AN EXQUISITE little pocket comb piece repeats in repoussé silver with hand chasing a floral and fruit design taken from an old Italian carving.

* * * * *

JEWEL boxes in rare woods are among the handsomest things of the season. They are in old mahogany, tulip, cocobola, rosewood and ebony, and are enriched with ormolu mounts chiseled by hand. Some of the cases are cabinet shaped and have separate drawers.

* * * * *

VISITING, account and bank books come in sets beautifully bound in old levant and in the novelty leathers—coon, elephant and crocodile. They are held in cases of carved woods of about half their height, and are attractive objects for a desk aside from their convenience.

* * * * *

APOSTLE spoons are regarded as modest and desirable wedding presents. The advantage is that they can be bought singly, and of a size from an after dinner coffee to a vegetable spoon; they are also always interesting as objects of art.

* * * * *

TODDY KETTLES in Japanese silver have made their place in the heart of the family. They are not necessarily for toddy; they may be used for tea. They are exceedingly pretty and are usually watched over from the cover by a squat Japanese god, very ugly, but very good natured.

Art Glass, Ceramics and Bric-à-Brac.

INGENUITY is taxed in providing novelties in frames for photographs which are more sought after than ever. A design which might be carried out more suitably is a small tree with branching silver leaves of which enameled pansies are the blossoms. On this tree, which is flat, small brass mounted locket-faced frames are hung like genealogical fruit. These are to receive the photographs.

* * * * *

SINGLE photograph frames are surrounded with silver wreaths, the flowers being represented by the blue and red stones that are seen in Norman and Swiss jewelry. Brass mounted frames appear in dull basket woven designs and enamel ivys are twined about them.

* * * * *

A JAPANESE photograph frame is of metal with lacquered landscape design and carvings in relief. This is supported on the back of a crouching half human monster, and is supported at the ends by two grotesque Japanese musicians.

* * * * *

COLORED glass, by reason of its beautiful color, is introduced

wherever a place can be found for it. One of the latest caprices in glass is to give it a diamond quilted appearance. This is found in lamp shades, flower receivers, and in the little fairy lamps that are in such general use. Town drawing rooms and boudoirs are kept in half light as more becoming. To enter at twilight a room in which the only light is a wood fire with here and there fairy lamps shining in the darkness like glow worms, is to get the benefit of a very picturesque effect.

* * * * *

CRUMPLED outlines become colored glass. Lamp globes are flaring, much turned over at the sides with crumpled or fluted edges, and the surface is covered with indentations that deepen and lighten in color.

* * * * *

HAVILAND fruit dishes are wreathed in vines and fruits that hang over the edges with natural effect.

* * * * *

ENAMELLED glass is being introduced here even in pieces as large as conservatory doors. In small objects it is very beautiful and has the effect of jewels. White glass is always the ground of enamelled glass. Gold is also lavishly used on white glass in jewel boxes, vases, and even on lamp globes.

* * * * *

SMALL brass scales for weighing letters are indispensable to ladies who carry on an extensive correspondence, and are made so outwardly attractive that they are warmly welcomed among the luxurious appointments of desks and library tables.

* * * * *

Two beautiful candelabra represent a branching tree of white and gold. In a niche of the tree sits a maiden in white and gold dreamily reflecting, with her finger on her chin. Her companion figure stands in a graceful attitude, she too in maiden meditation.

* * * * *

BERNIS-MARTIN grows in favor. Double-racked music stands are brass mounted with bernis-martin portfolios. Brass montabers have double shelves of bernis-martin. The small shield-shaped backs in chairs are of bernis-martin. From panels in cabinets to piano covers, bernis-martin rules.

* * * * *

THE Barye exhibition has given a new impetus to bronzes, and especially to casts of animals. Sometimes this taste extends to more precious metals. One of the fancies of the season is a white enamel cat with diamond eyes.

* * * * *

AMONG the novel umbrella handles is a nest of young frogs invaded by some vagrant crabs. This is carved in ivory, and the workmanship is, of course, Japanese. Another Japanese fantasy is a group of monkeys and frogs.

* * * * *

A BEAUTIFUL glass beer set has a fluted body with mountings of silver plate. The mounting, which is perforated and chased, surmounts the jug, the glasses rest in perforated cups, and all are held on a plate glass tray.

* * * * *

COLOGNE sets consist of three large cut-glass bottles with prismatic stoppers. These are set in brass with enamel incrustations, and so arranged that they can be carried about by a handle.

* * * * *

CALENDARS take the form of Egyptian temples in black enamel bronze with brass mounts. There are sphinx-like figures at the corners. Three brass projections regulate the days, weeks and months.

ELSIE BEE.

Copyrighted 1888 by Charles A. Bucklin

Mechanical Ocular Defects.

Their Nature, Cause, Correction and Relations to Functional Nervous Diseases.

EDITED BY C. A. BUCKLIN, A. M., M. D., NEW YORK.

[The aim of the author is to produce a clear and thoroughly practical course of instruction on the subject of "mechanical ocular defects," which is entirely void of useless technicalities and within the easy comprehension of every thinking student without his having had any previous technical or mathematical education.]

WE WILL continue the further consideration of muscular defects.

Grotesque positions of the head are very common results of muscular defects. The head is always turned in the direction which the paralyzed muscle formerly moved the eye. If both superior recti muscles are weak the tendency of both eyes is to droop. This difficulty is overcome by throwing the head backward. The following example illustrates this class of cases: The Rev. P. S. was undoubtedly an unpopular clergyman; he walked about with his head decidedly thrown backward, and upon meeting an acquaintance he threw his head with a spasmodic jerk still further back, the act of bowing simply bringing his head to its first position. This personal peculiarity was considered very generally as an evidence of cold affectation, when the truth was the man could not raise his eyes to the level of the face he wished to observe without throwing his head back. I can not resist the conclusion that the general unpopularity of this clergyman was largely due to the defect of his ocular muscles.

Weakness of both inferior recti muscles requires the head to be thrown forward to overcome the defect. This gives to the individual an appearance of melancholic stupidity. The chin is carried down on the chest and with each attempt to observe closely the faces of friends, especially if they are seated, there is an additional movement of the head forward. I remember a young boy who worried his parents very greatly because they feared he was affected with some brain trouble which produced this appearance of mental depression. He had received all kinds of treatment for his apparent mental condition; among other forms of treatment he had received a thorough course of bromides. A weak pair of prisms, base down, combined with a positive assurance that the trouble was entirely due to trouble with his ocular muscles, quieted all uneasiness in the minds of the parents, and produced a very satisfactory result in the improved condition of the boy.

Paresis of one of the lateral recti muscles will cause the head to be turned toward the weak muscle providing the advantages gained by this movement are sufficient to compensate for the annoyance experienced as a result of the weakened muscle.

Paresis of the superior oblique muscle alone is quite frequent because this muscle has an independent nerve supply, while paresis of the inferior oblique is complicated by other muscles being involved in the paresis which have a common nerve supply with the inferior oblique.

Paresis of the right superior oblique muscle frequently causes an individual to carry his head turned slightly outward and downward in such a manner that the vertical axis of the eye is rotated slightly outward. The position of the head is characteristic and the diagnosis of paresis of the superior oblique can be made as far away as the position of the head can be observed.

Paresis of the left superior oblique muscle produces exactly the opposite effect.

Diplopia. When by changing the position of the head in such a way as to avoid the use of the faulty muscle, the individual is not able to maintain bi-nocular vision, we have diplopia or double vision.

One eye deviating from its usual position makes it impossible for the retinal image to fall on corresponding points of the retina; con-

sequently each eye receives a retinal impression from the same objects on different points of the retina. This gives the brain the sensation of two objects located in entirely different positions. With the straight eye the object will appear in its true position; with the deviating eye the object will appear to be located where objects formerly were which cast an image on that portion of the retina now exposed to the retinal image.

The necessary deviation of the eye to produce diplopia is not sufficient to locate which one of the ocular muscles is the faulty one. We are therefore obliged to draw our conclusion from the relative position of the double images.

If we place a red glass before the right eye and direct the attention to a candle at twenty feet and the red candle is to the left, we have *crossed diplopia*. This defect can only be produced by the deviation of one eye outward; consequently the fault lies in one of the internal muscles. The turning of the right eye outward would be the only movement which could bring the portions of the retina in the visual line upon which objects to the extreme left had formerly cast an image. The diplopia being crossed, one of the internal recti muscles must be paretic. The next question is to decide which one of the two is at fault. If on moving the candle several feet to the right of the patient, it is found that the lights come nearer together, the right internal rectus is the faulty one; this fact is especially pronounced if on moving the candle toward the left eye the lights appear to separate more widely. Should the lights, on the other hand, approach each other when the candle is carried to the left, then the left internal rectus is the faulty muscle.

If, when the red glass is placed before the right eye, the red light appears to the right, then we have *homonymous diplopia*. To produce this phenomenon, one eye must deviate inward; consequently one of the external muscles must be affected. If, on carrying the candle to the right, the lights approach each other, the left external rectus must be the faulty muscle. If, on carrying the candle to the left, the lights approach, the right external muscle must be the faulty one.

Vertical diplopia exists when the double images are seen to stand squarely over each other. The difficulty, when slight, is difficult to locate, as a defect in the superior rectus of one eye produces exactly the same results as a defect in the inferior rectus of the opposite eye. However, if a candle be observed at about the same height from the floor as the eye which with one eye during the binocular visual act appears in its normal position while the image in the other eye appears decidedly displaced above or below, a fair conclusion may be drawn as to which eye has the defective vertical muscle. Diplopia due to paresis of one of the oblique muscles gives a certain slanting position to one of the visual images which is never present as a result of paralysis of one of the direct ocular muscles.

Diplopia is usually due to a partial or complete paralysis of one of the ocular muscles which control the relative positions of the visual axes. It may be due to some error of refraction which, notwithstanding normal ocular muscles are present, makes binocular fixation impossible owing to the extreme nearness of the far point of distinct vision. Myopia of a high degree is the one error of refraction which may cause diplopia.

Diplopia from paralyzed ocular muscles has as its foundation some acute infectious disease, an exudation or tumor of the brain. Quite frequently with the recovery from the infectious disease the paralyzed ocular muscles also improved or are wholly restored. Syphilis and diphtheria are the two common causes of diplopia. The primary treatment of the infectious disease is the first step to be taken for the relief of diplopia. The second step is gymnastic exercise of the weak muscles by frequent experiments in attempting to overcome weak prisms with the bases toward the muscles to be exercised; the strength of these prisms is gradually lessened till the weakest prism is reached through which single vision can be maintained. The muscles are also further stimulated to action by the use of electricity. In the majority of cases the difficulty disappears

under the above treatment, but occasionally the affected muscle remains in a permanently weakened condition. This permanent weakness may be compensated for by a prism with its base toward the weakened muscle. While this method frequently gives great relief to the annoying symptoms, still it must be remembered that a prism is at best a poor crutch to take the place of an active muscle. Prisms give greater satisfaction in vertical diplopia than in any other form of double vision. The tenotomy of the opposing muscle is also a very valuable means for overcoming the difficulty. The opposing muscle should not be cut till sufficient time has elapsed to demonstrate beyond a doubt that the affected muscle is permanently weakened. The importance of this caution being observed is evident. Should the affected muscle recover its former strength, there would be a muscular weakness in the direction of the opposing muscle operated upon.

Muscular Asthenopia. This is one of the most troublesome chapters connected with the entire subject under consideration. In former years it was a very much neglected subject but at the present time it is receiving so much attention that it is being overdone in a most ridiculous manner.

When some one of the twelve muscles used in directing the visual lines are weakened to such a degree that the individual can only by a struggle maintain bi-nocular vision then a most annoying sensation of fatigue is experienced. These annoying sensations have been named muscular asthenopia. The individual complains of weak or painful vision. Errors of refraction are carefully searched for to account for the symptoms complained of. If they are found and their correction relieve the annoying symptoms then the case is a simple one and muscular defects are probably absent. If errors of refraction are not found or if the correction of those found do not relieve the symptoms then it is immediately suspected that some one of the ocular muscles is being severely strained in maintaining bi-nocular vision. Here again as in diplopia we are obliged to resort to a series of experiments for the purpose of determining which of the ocular muscles is being unduly strained. In diplopia one muscle or set of muscles was not meeting the requirements necessary to maintain bi-nocular vision. In the present case the muscles are all meeting the requirements necessary for maintaining bi-nocular vision but one is being painfully fatigued in performing the required task.

In diplopia it was an easy task to locate the muscles which were faulty. In muscular asthenopia the task is much more difficult. The technical details of the experiments necessary to locate a weak muscle are simple and easily carried out. The great difficulty arises from the fact that the patient may entirely deceive us during the short time of the experiment by exerting his muscular energy to its greatest capacity. Another patient may have healthy muscles and be entirely ignorant of the necessary muscular exertion required for overcoming double vision. Again, double vision having been artificially produced by prisms, the eyes in many persons have no incentive to fix on a bi-nocular horizontal plane and much less on a bi-nocular vertical line. The eyes of many persons having normal muscles wander about during this experiment in a manner which is adverse to any rule, law or reason.

I meet patients who for the reasons above given have weak muscles and who are able to stand all the tests which indicate the existence of normal muscles. I also meet patients, who have normal muscles as demonstrated as the result of a series of experiments, who are not able at one or more sittings to comply with any of the requirements laid down as a test for demonstrating the existence of normal ocular muscles.

Time has convinced me that there are many more difficulties in the way of demonstrating the existence or non-existence of normal ocular muscles than is acknowledged by those who pose as authorities on this subject.

The old experiment of Graefe for determining the existence of

muscular equilibrium has been revived with great force during the past few years, and there appears at present to be a perfect craze on the subject of weak ocular muscles.

The horizontal equilibrium of the ocular muscles is tested by placing a prism of 8° base exactly up or down; the attention is then directed to a lighted candle. If the horizontal muscles are balanced, two candles will be seen, one exactly above the other. When they are not balanced there will be a decided lateral displacement. Covering the right eye with a red glass, one will judge immediately from the position of the red candle, which muscles are at fault. If the red candle is seen to the left of the white candle, the internal recti muscles are weak. If the red candle is seen to the right, the external recti muscles are weak. The prism base in or out which is necessary to bring these two candles exactly over each other measures in degrees of prism the weakness of the faulty muscle.

The existence of vertical equilibrium is of much more importance for comfortable vision than that of horizontal equilibrium. Vertical equilibrium is tested for in the following manner: A prism of 10° is placed before one eye, base in, and a red glass before the other eye. The attention is then directed to a candle at twenty feet. If the muscles are balanced, the two lights will appear at exactly the same level. When one light stands decidedly higher than the other the vertical balance does not exist and the prism base up or down which brings the lights to the same level, represents in degrees of prism the amount of the defect.

Another method of examining for weak muscles, which appears to be more practical, depends upon the comparison of how many degrees of prism each set of muscles can overcome without producing double vision with the degrees of prism the same sets of muscles can overcome in the average individual.

The external muscles of the average person will just overcome 8° of prism without producing double vision. I have, however, seen the ability of the external muscles sink to two degrees of prism without producing any annoying symptoms while in another case the same degree of weakness produced most annoying symptoms when using the eyes for distant vision.

The internal muscles should as a rule with a little training overcome twelve to twenty-four degrees of prism without producing double vision. The vertical muscles should not under any circumstances overcome more than three degrees of prism without producing double vision. The ability to overcome more than three degrees of prism with the vertical muscles indicates that they are not properly balanced. In fact the smaller the degree of prism which can be overcome by the vertical muscles the more perfect is the balance between the vertical muscles. With the above facts before my readers and a few hours spent in experimenting they will be able to readily grasp the theory and practice of testing for weak ocular muscles.

It will be remembered that to test the strength of a muscle the base is turned away from the muscle to be tested. When a prism is worn to assist a weakened muscle its base is always turned toward the weak muscle.

The next class in Optics will commence January 10th, at 2 P. M. Students desiring to take the course should apply as early as possible.

RECOMPENSE.—The one-half of the Pierret prize (of Paris) of 500 francs, to the best written answer to the question, "which is the best form of the balance spring, to produce an isochronal motion of the balance?" the answer to be delivered to the Syndical Chamber of Horology at Paris, was awarded to L. Lossier, director of the School of Horology, at Besançon, the other half to L. Lecocq, watchmaker to the marine, Argenteuil.

Problems in the Detached Lever Escapement.

BY DETENT.

BEFORE attempting isochronal adjustment it is necessary to comply with certain imposed conditions, preëminent among which are: first, that the balance spring must be true in the round and in the flat; second, there must be length enough of the balance spring to insure certain results to be spoken of further on. This length usually embraces from twelve to fifteen coils when a close coiled spring is employed. Another precaution is necessary—the escapement must be in perfect order and the watch be able to run on half-time (that is, without a balance spring). Now arises the question of relative merit between flat and Breguet springs, which two forms of spring have been the source of endless arguments among adjusters. The facts seem to be about as follows: some adjusters succeed better with one kind than with the other, but practical experience shows that both flat and Breguet springs are capable of fine isochronal adjustments; but the liability of flat springs to “jump” the regulator pins should condemn their use in any but the commonest kinds of watches. But in our consideration of the subject we must accept the situation as it is and make up our minds that there are a great number of watches employing flat springs which have to be fitted with new springs, and these springs adjusted, if only approximately. Adjusters are usually very reticent about their methods, and the less skilful they are the less they have to say about their art. Such workmen usually have certain “thumb rules” they go by; if one does not succeed they try another.

We will first speak of the resources open to the workman for obtaining isochronism in flat springs. Flat springs which are to be adjusted to isochronism should have, as remarked above, 14 or 15 coils. A still higher number of coils would be desirable for the purpose of obtaining isochronism, but springs with such a large number of coils are objectionable for position adjustments. The usual method of adjusting a flat spring to isochronism is by pinning the spring into the hairspring stud so the point where it is pinned into the collet comes opposite to the regulator pins when the regulator stands in the middle of its arc; and then bringing the watch to time by changing the balance screws. Of course a spring should be selected which is very nearly correct. Consequently the taking out or putting in of a pair of screws would bring the watch nearly right. By cutting out a little from a screw underneath the head we can increase the rate a minute or two a day; or by punching out some small washers of the size of a balance screw head from thin sheet silver; or even the same kind of tinsel used for dial washers, and placing them under the screw head, we can cause the watch to run as much slower.

As soon as the watch is brought to within ten seconds a day of correct time the adjusting to isochronism can be commenced. If the balance is one which has been previously adjusted to heat and cold, it is highly probable that we shall have to change no more than one pair of screws to restore this adjustment.

To properly judge of the comparative duration of the long and short vibrations we must provide two mainsprings, one quite weak, which will produce about three-quarters of a revolution of the balance, and another which will produce one and one-half revolutions. It may not be amiss, for the benefit of the younger and less experienced members of the craft, to define what constitutes what adjusters term a full revolution of the balance. A full revolution of a balance is an excursion in each direction of 180 degrees from the point of rest; three-fourths of a revolution is an excursion of the balance of 135 degrees in each direction from the point of rest. We first place the weak spring in the watch and wind it enough to secure our three-quarters of a revolution, and note the rate carefully by a good pendulum regulator. The winding should be done every hour or two to insure, as nearly as possible, constant vibration of

three-quarters of an arc. We continue this for twelve hours; and repeat the timing for three or four periods of twelve hours.

We will suppose on these trials that we find the average gain to be $6\frac{1}{2}$ seconds in twelve hours; we make note of it, and change our weak mainspring for the stronger one, in order to obtain our long vibrations. We time again with our pendulum regulator for twelve hours, with care to keep our long vibrations constantly at the same arc, that is, at one and one-half revolutions, and again carefully note the rate for twelve hours. For illustration, we will suppose the watch gains only $4\frac{1}{2}$ seconds in twelve hours on an average of three or four comparisons with one pendulum regulator. What does this tell us? Simply that our long vibrations are the slowest. This is the usual result in attempting to adjust flat springs to isochronism, *i. e.*, the long vibrations are the slowest. Now comes the difficult operation—to quicken the long vibrations. To accomplish this result we have at our command several resources.

The reader will remember we pinned our spring into the stud so the pin in the collet stood opposite the regulator pins when the balance was at rest; this is bringing the *points de attach* in a line, as the operation is termed. The theory of this method is, that every coil of a flat spring has an isochronal point in it, which as a rule is directly opposite to the point where the inner end is pinned into the collet. In the case we have in hand, our watch is losing in the long vibrations, and the question is, which way must we shift our outer points of attachment which here are the curb pins, as we intend to leave our regulator in the center of the arc, and bring, as above mentioned, our watch to time by the aid of the balance screws.

The long vibrations can be quickened by letting the balance spring out a little. True, the watch will fall off in its rate, but it will quicken the long vibrations. The question is whether we can secure acceleration enough in this way. If we cannot, we have, however, other means at our disposal to accomplish this result. It is a well known fact that the atmospheric resistance is a large factor in isochronal adjustments. Supposing we had a balance spring which was perfectly isochronal with a balance containing 12 brass screws, if we changed the brass screws for gold of the same weight our watch would gain in the long vibrations, as the gold screws would offer less resistance to the atmosphere. The change would be still more marked if we should substitute platinum screws for gold, as gold alloyed to 10 or 12-k. is only a little over one-half the specific gravity of platinum. Many adjusters complain of having difficulty in adjusting with platinum screws. The writer also experienced considerable trouble until he hit on the plan of counter-sinking entirely through the brass rim of the balance, letting the platinum screw hold entirely in the steel. Since adopting this plan platinum screws serve an admirable purpose. We cannot at this writing consider all the resources for adjusting a flat spring, consequently we will have to let the matter rest until our next interview.

PRESENTS.—The presents tendered by the embassy from Zanzibar to the Imperial pair of Germany consist of the following pieces: To the Emperor, 1, a most valuable sabre, the hilt and sheath of which is of chased gold work; 2, a silver plate with inlaid gold work; 3, a coffee pot and three small vessels of gold and silver; 4, two dozen knives in Lamu work with ivory handles and inlaid gold, and 5, a dagger with ivory hilt. The principal present for the Empress was a precious necklace of gold links, 8 centimeters broad, with a heavy gold pendant, 10 centimeters broad. To this belonged two pairs of bracelets in artistically chased work. Several changes were made in the presents for the ambassadors. Each of them at first received a gun and a gold watch with chain. The watch has upon the dust plate the portrait of the Emperor and the dedication, outside the monogram in brilliants.



TO PREPARE SHELLAC FOR USE.—Shellac can be dissolved in alcohol, and kept in a liquid form in a closely-stoppered bottle, to prevent evaporation. To use it, it is only necessary to apply it with the pointed end of a pegwood or small camel's-hair brush, and heat the object over a lamp, when the shellac will quickly solidify. Or it may be used as received from the drug store, in chips. A good course to pursue when setting pallet jewels, ruby pins, etc., is to heat a piece over the lamp and draw it out to a long, slender thread, then break the end in small particles of suitable size for cementing the jewel; by this means the shellac may be placed just where it is needed, and it will not run over the pallets or table roller.

ENGRAVING.—Let the learner of engraving remember that in cutting the shaded strokes (or heavy lines) of script lettering, the graver should be slightly turned over from the workman, so as to give a bevel to the outer side of the stroke; and, as the shaded lines of script lettering are cut from either side inwardly, this method of cutting causes the edges of these lines to be sunk straight down from the surface, thereby giving a sharper, clearer and better appearance to the work than by following any other system. In cutting the hair or fine lines to script, the graver should be held upright such strokes being beveled from either side.

TO REGULATE A FINE WATCH.—Some time ago, a correspondent desired to know how to regulate a very fine watch, made by a certain reputed English watchmaker. He stated that, although he "had tried to alter the balance spring by taking up and letting out, yet he could never obtain the desired effect." When a watch has no regulator it is timed by the timing screws in the balance rim, at the end of the center bar. They are turned very slightly inward, to make the watch gain, and outward, to lose. Both screws must be squarely turned, or the balance will be thrown out of poise, and regular running will be impossible. Should the amount of regulation wanted be too much to be easily corrected by these screws, it shows that there is some fault in the movement, which should be repaired. This fault may be in the escapement, or elsewhere. It is sometimes caused by the balance rim having been injured by careless handling. But the hairspring should never be disturbed in a fine watch, unless in some very exceptional circumstances. Its length and curvature have probably been carefully adjusted to secure isochronal vibrations of the balance, and taking it up or letting it out will at once damage or destroy isochronism. Even taking up a hairspring and afterward putting it back where it was will often spoil it for fine running, because the shape of the spring and the condition of the metal have been so altered by the pressure of the pin in the hole, the bending or straightening of the coil, etc., as to unfit it for isochronal action. It is difficult, in fact, for a workman who is not fully posted in fine watch work, to handle a fine movement without injuring it in some way, although he may not know how he did it, or discover the fact until the owner complains of its inferior performance.

DROP IN CYLINDER ESCAPEMENT.—Though excellent for ordinary pocket watches, the cylinder escapement cannot be said to be equal to the lever and some others, where great accuracy is required. The drop of the escapement is the cause of much trouble to watch repairers, but the following method will enable them to ascertain how far the drops are equal and correct. The movement being slightly wound up, turn the balance with a fine wire or strip of paper till a tooth falls; now try how much shake the escape wheel has and allow the tooth to escape; then try again, and go all around the wheel to see how all the teeth and spaces agree in size. To correct any inequality is certainly a job for an expert hand, and directions will not avail much unless to an expert. When the tooth contained

within the cylinder has no freedom and rubs at the point and heel, there is no internal drop; when the tooth has escaped, and the cylinder rubs on the point of one tooth and the heel of the next, then there is no outward drop. The internal drop is increased by reducing the length of the teeth; the external drop is increased by increasing the space between the teeth. When the drop is very slight, the watch is very liable to stop through excessive friction; in the case of unequal drop, the rate of a watch cannot be maintained, and occasionally stoppages will occur. This fault is found by dotting the balance with spots of rouge and carefully noting the oscillations, which, if unequal, indicate unequal drops. Though this is the usual course, the same effect may be the result of some teeth lifting more than others. A noisy drop is caused by badly polished surfaces, and in such a case the wheel of the cylinder should be carefully noticed.

LUBRICATING.—An excess of oil will cause an infinity of errors to arise, and should be most carefully guarded against. The points of the escape wheel teeth may catch in a slight burr, which is sometimes left at the lips of the cylinder, and of course would stop the watch. This is remedied by polishing the cylinder and rounding off the points of the escape wheel teeth. The balance spring should be pinned up to have the escapement in perfect beat. This is done by pinning the stud on the spring so that it is exactly over a dot marked in the balance for the purpose of showing the position. Sometimes the lower corner of the heel of the escape wheel tooth touches the inside of the cylinder and stops the watch. But all these defects may be seen, or rather felt, by careful trial. If there is any doubt of parts touching where they should not, a spot of rouge put on will at once mark the place where it touches.

GOLD VARNISH.—The following is a good recipe for preparing a gold varnish for brass objects, instruments, etc.: Gum lac, pulverized, 90 grains; copal, 30 g.; dragon's blood, 1 g.; red sandal or sanders wood, 1 g.; pounded glass, 10 g.; strong alcohol, 600 g. After sufficient maceration, filter. The pulverized glass simply serves the purpose of hastening the solution by interposing between the particles of gum lac and copal.

TO FASTEN LETTERS ON GLASS.—For fastening glass letters, figures, etc., on glass (show windows), so that they, even when submerged in water for several days, will not become detached, use an India rubber cement. The best for this purpose consists of one part India rubber, three parts mastic and fifty parts chloroform. Let the mixture stand for several days in low temperature, to dissolve the cement. It must be applied very rapidly, as it becomes thick very soon.

AN ELASTIC LACQUER.—A lacquer said to be of great elasticity perfectly supple and not liable to peel off, is made in the following manner (all parts are by weight): About 120 parts of oil varnish are heated in one vessel, and 23 parts of quicklime are put into 22 parts of water in another. As soon as the lime causes an effervescence, 55 pounds of melted India rubber are added, the mixture is stirred and then poured into the vessel of hot varnish. The whole is then stirred so as to be thoroughly mixed, and then strained and allowed to cool, when it has the appearance of lead. When required for use, it is thinned with varnish and applied with the brush, hot or cold, preferably the former. This lacquer is useful for wood or iron, or for walls; it will also render cloth, paper, etc., waterproof.

GRAVER BLADE.—A graver blade having its cutting edges at right angles with each other, as they must be if the graver is square, will make too wide and shallow a stroke. It will be found that from the edge of the graver on one side to the corresponding edge on the other side, crosswise, as it is fitted into the handle, measures one-third more than it does across either of the flat sides of its belly. For certain kinds of work, the tool to be used should be diamond in shape endwise, and the distance from edge to edge crosswise of the blade should be equal to a width of a side of its belly.

Screw Gauge.

IN ARRANGING a set of tools, one of the first conditions for insuring rapidity and certainty in work is to determine upon a common measure between the brooches, taps and drills; and this can easily be done in the following manner:

Procure a good screw-plate and a draw-plate for reducing round wire to any required diameter. Draw out a piece of brass or good iron wire to such a thickness that, when slightly tapered at the point, to facilitate its insertion into the first hole of the screw-plate, a good full thread is obtained without producing too much shaving or straining the metal. The screw is cut off about half an inch beyond the thread, so as to have with it a portion of the metal from which it was produced. The formation of the thread spreads the metal outward, so that the screw is nearly always thicker than the smooth portion. The wire is again passed through the draw-plate until reduced to the thickness suited to the second hole on the screw-plate; a screw is formed, as in the first instance, and so on throughout the series.

When this operation is completed, take a thin plate of a circular or rectangular form, and around its circumference cut a number of notches, gradually diminishing in size, that correspond with the cylindrical uncut portions of the screws. Mark these recesses with numbers corresponding with those of the screw-plate and, opposite to each, drill a hole of the same diameter as the notch.

The first series will serve to measure, without removal from the lathe if desired, the diameters of spindles on which threads are to be cut; and the round holes are useful for selecting the broaches and drills to prepare holes that are to be tapped. If the gauge is well made and the drills employed are capable of producing a smooth and clean cut hole, it will be found that the thread can be at once formed without there being any occasion to use a broach. When the correct size is thus determined upon, the hole can be tapped by use of the bow, or one of the special tools described in the following:

METHODS OF TAPPING HOLES.

It is needless to refer to the method of tapping by hand, as it is well known to all practical men.

Tapping in the mandril.—The plate of a watch is gripped in the dogs of the face-plate, the hole to be tapped being centered by means of the pump-center, which is then withdrawn and a tap held to the hole; the face-plate is then caused to rotate, either by the hand resting on its circumference, a slight backward motion being given after each advance, or the motion may be continuous and given by the handle. In the latter case, however, the tap must have a good cutting edge, and only be held in the hand with the degree of force required to make it cut, so that it may rotate without breaking in case the resistance becomes too great.

The top may be steadied on the T-rest, or the following plan, which is equally applicable to other forms of lathe, can be resorted to: Mount the tap in a spindle that traverses the hole of the loose poppet-head, either adapting it as a runner or of the same diameter as a hole in a collar fitted into either end.

It is obvious that, with such an arrangement, it is possible to tap in the ordinary way, maintaining the plate stationary with one hand while it is rotated with the other. Indeed, the inertia of the plate is often sufficient without holding it. As with the succeeding methods, a certain number of preliminary trials will be found necessary.

To tap with a mainspring winder.—The ordinary mainspring winder will, if the clickwork is removed, be found very convenient for tapping holes, and, indeed, for forming the external thread on screws. Having removed the winding arbor, replace it with a tap carefully centered; then introduce its coned end into the hole in the plate, which must be pressed forward while the handle is turned, a short, backward motion being given to it at frequent intervals. When the tap is engaged sufficiently in the hole, it is merely necessary to maintain the plate at right angles without applying pressure.

To tap with a bow.—Instead of the mainspring winder, one of the small drill-stocks, to be driven by a bow, consisting of an arbor with a coned hole at one end and a ferrule at the other, supported in a frame that is clamped in the vise, may be used. This instrument may be obtained from any material house.

The bow being on the ferrule and the tap properly centered in the arbor, the hole is held against the coned end and the bow worked with an alternate forward and backward motion similar to that of the handle when the mandril is used; but if the tap has a good cutting edge and the bow is strong (of steel or cane), a hole may be tapped with a single stroke of the bow. After a few trials the method will be found very easy and certain.

A regular and rather slow motion should be given to the bow, which should be long and strong. It is well to ascertain the number of revolutions of the ferrule that correspond to a stroke of the bow, so as to insure that the tap is not introduced to a greater depth than is required. If it is desired that the screw work easily in the hole, the tap should be moved several times backward and forward.

The little turns here referred to, some of which are perforated throughout their entire length and others only at one end, are very cheap and will be found useful; they can be adapted to receive drills, broaches, taps, etc.

To tap in the ordinary lathe.—In factories it is a common practice to tap the holes in plates, etc., and even to cut the threads of screws in a lathe specially arranged for the purpose. The tools adapted for such work are of two kinds: in some the tap enters to the required depth, when it is immediately arrested, disconnected, and then rotated in an opposite direction; in others the tap advances to a definite point and is immediately withdrawn. As a rule, however, the tap remains stationary and the object is caused to rotate.

There are several other methods of tapping screws adapted to special kinds of lathes and turns used in Europe; the above methods, however, are those most in use.

Series of taps, broaches and drills can be prepared on the basis of this gauge: they should all be marked with corresponding numbers, and the broaches may be fitted with brass rings to indicate the extent to which they are inserted. Such a set, if complete and maintained in good condition, will be found to immensely facilitate the work of the watchmaker, to effect a great saving of time and to avoid breaking taps and shaking up the holes of screw-plates.

Pliers for Straightening Bent Pivots.

SIMPLE though the operation of straightening a bent pivot may be, it is nevertheless difficult to straighten a thin pivot, because the repairer has in many instances not a suitable tool for doing it. The ordinary flat tweezers slip off easily, and, besides this, it is generally a risky job because they are too plump. The whole hand is needed for holding them, and the delicate touch required for straightening a thin pivot is impaired.

An excellent tool for the purpose is shown in the accompanying



cut, which has none of the various objections urged against the different kinds of ordinary pliers. The tool can already be found in the different material stores of the continent and Switzerland, and can for that reason no longer be called a novelty; still, as far as known, watch repairers are not as generally acquainted with it as they should be. Any person, however, can make one easily from an old and strong pair of flat pliers.

Simply shorten the points at a place where they are from about 3

to 4 millimeters broad. Next bevel the stumps from the outside, as is seen at *a a* in the accompanying cut, and flatten the interior faces, so that they will close truly. Harden the points, anneal blue, and grind them nicely, when the tool is ready for use.

The repairer will find at the very first use that he can straighten a pivot with much greater ease than with the pliers as ordinarily used—because it will not slip off with the broad flat ends, and he can manipulate them far more readily than the ordinary flat pliers.

Breguet's Escapement with Natural Impulses.

THE greater number of escapements in use at the commencement of this century labored under the defects that they either would stop easily or had a dead beat, or that their parts rapidly destroyed each other by the roughness of certain frictions, and interposition of jewels. It is doubtless for the purpose of correcting these several defects that Breguet contrived this escapement, which he called "the escapement with natural impulses," because the two levers which are in activity during the one and the other lifting, yield in the same direction and under the operation of a force, the direction of which deviates very little from the vertical upon the line of centers. Below is a representation and description of this escapement.

The last wheel *d* of the train drives by means of a depthing a

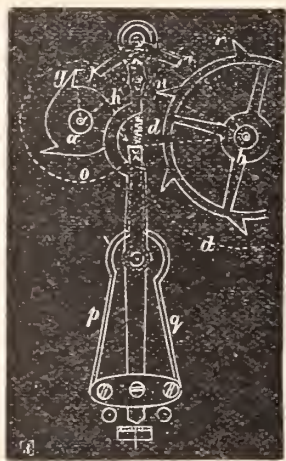

second smaller wheel; upon the axes of these two depthing wheels are fastened the two escape wheels *b* with six teeth and *a* with three.

The repose, taking place immediately one after the other, of the wheels *b* and *a* occur upon the lever *Z* which moves upon the same center as the fork does. This latter is in all respects similar to that of the anchor escapement.

It is easy to understand the operation of the whole. By the winding of the spring, the escapement is actuated; the four wheels commence to go. The tooth *g* by meeting the impulse lever *j* drives it as far as *h*, and thereby impels the balance. The piece *Z*, which was just now pushed to the right, there opposes the tooth *u*, and stops it. All the four wheels are then at repose.

On the return of the balance, the fork, which was carried along to the left, unlocks the wheel *b*, and the tooth *r*, which was situated at *i*, enters into depthing with the second impulse lever, in order to then fall again upon repose at *u*, at the moment when the tooth *g*, after it has left *h*, reposes upon the piece *Z*, which has arrived again at its initial position.

This piece *Z*, which is movable upon the axis of the fork, is in the prolongation of this fork retained by the two lateral springs *p* and *q*. This arrangement is for the purpose of preventing an encounter with the piece *Z* with the back of a tooth, when one of the wheels *a* and *b* is carried back by one of the impulse arms (this can occur when the mainspring has entirely run down). In this case, the piece

Z goes to one side and permits the tooth to return, whereupon it returns to its normal position.

Although the conditions established by Breguet were well complied with, nevertheless, this escapement, ingenious and well executed though it be, like all the productions of that celebrated watchmaker, has furnished no good results. At any rate, however, this work has answered its purpose well, because it demonstrated incontrovertibly, that an increase of the inertia of the movable parts and points of contact is the greatest hindrance to the regularity of the rapid and, so to say, instantaneous operations of an escapement. Breguet's escapement has acquired a historical fame; this inventor has constructed several such escapements, of which the escape wheels are of the same diameter, and the wheels depthing into them are of the same size.

Jerusalem to be the Initial Meridian.

SINCE the great development of maritime intercourse, numerous proposals have been made to solve the problem of establishing an international zero or initial meridian, so that the nautical and chronometrical calculations of one nation should be readily understood by all others, and serve them as data without further need of re-computation. England, whose maritime interest is more largely developed than any other nation's, clings to its Greenwich meridian; France computes from Paris; the United States from Washington, etc., but for the purpose of unifying the interests of all nations, an international geographical congress will at an early day convene in Paris, and again essay to solve this problem of establishing a general international initial or zero meridian, after various failures to do so in former years. The fact that the several maritime nations calculate from a meridian which interests some prominent place within their own country, has led to many equivocations, but the several representatives from each nation sent, for instance to the last conference held in Washington in 1884, clung too stubbornly to their old wedded ideas and prejudices. It has since become more fully recognized that the subject requires thorough investigation, and the belief is entertained that the present congress will come to an understanding. The proposal of locating the initial meridian at some point in the ocean was for some time seriously entertained and that of the Behrings strait was about to be adopted. After full debate, however, the unfitness of an oceanic meridian was recognized, as the zero meridian must be located at some stationary point, the position of which in comparing to others, must be under full control or access. But where is there such a point of which it might be said that its location in a foreign country does not wound national vanity? A Frenchman, De Laharpe, claims to have made this discovery, and the Academy of Sciences of Bologna supports his proposition: Jerusalem, which by the mediæval geographers was regarded as the center or "hub" of the earth, and it is to be restored to its pristine glory; the noon line of the Holy Sepulchre is to be the new zero meridian. Professor Supan publishes in *Petermann's Communications* a defense of the suggestion, and says: "There is no doubt but that the choice of Jerusalem has everything to recommend it. No nation, not excepting even the English, would dare to raise objections to this locality hallowed by the well-known tragedy enacted there. Turkey even, would feel itself highly complimented by the choice. Most remarkable of all, however, the geographical locality of Jerusalem has not yet been determined precisely, and observations differ about one-third of a mile."

PIVOT HOLES.—If the escape wheel pivots are too large, an immense amount of trouble will be caused. All the end shakes and side shakes of the escapement require most careful adjustment.

The Barometer Compensation on the Pendulum.

ALTHOUGH the following article is in several respects of a theoretical rather than a practical value, the institution of "Washington time," supplied by the Western Union Telegraph Co. to many watchmakers in the country, especially in large cities, rendering unknown various difficulties mentioned in it, it is nevertheless of a highly interesting nature. The endeavor of thinking horologists to overcome the barometric errors has led to the invention of many ingenious devices. Baily, in his celebrated paper read before the Royal Astronomical Society, in 1823, seems to have been the first who drew the attention of astronomers to these sources of irregularity. Next, Dr. Robinson, in his Memoirs to the same society, in 1833; Bessel's and Sabine's researches also threw much light on it, while Dr. Hipp, of the Neuchatel Observatory, arrived at highly ingenious conclusions. Owing to the length of the article, however, THE JEWELERS' CIRCULAR must at present abstain from making further remarks on this subject interesting to every one connected with the horological art.

For a number of years, says C. Beuchtel in the *Deutsche Uhrmacher Zeitung*, have I endeavored to overcome the significant influences exerted by the variable pressure of the air upon the pendulum oscillations, and I will acknowledge at once at the commencement that I succeeded in doing this only very lately, with a certain fair degree of satisfaction. By reason of the many experiments which I instituted on this subject, I have, of course, gathered large experience, which might also be of value to others; I believe, therefore, that I can be of some service to my colleagues, and deter them from instituting experiments lasting throughout a number of years, by communicating to them in the following, the outlines of my experiments and results.

Everyone who is engaged in timing marine chronometers and watches of precision, must acknowledge that the errors made by the standard clock, and which are not easily ascertained are so disturbing upon the work in hand, that one may be driven well nigh to the "ragged" edge of despair, by, for instance, the reappearance of an error to a highly increased quantity, which he imagined only yesterday to have removed. At the commencement of the time, when it became of vital interest to me, to study the rate of my clock with the greatest possible attention, I believed to have done enough by jotting down the barometer heights and taking the mean for each one week. As I had the opportunity of astronomically ascertaining the rate of my clock once a week, it appeared to offer no great difficulties to deduct from both factors, viz., the mean weekly barometer height and the rate of the clock, beside the correction of the clock in the ordinary meaning of the term, also the correction for the different barometrical heights. This enabled me after six or eight months, to make out a table, in which the correction of the changes of air pressure could be written. But the barometer heights had to be ascertained very often, the mean calculated from them, and the duration also had to be considered in the computation before I could ascertain both height and rate with approximate precision. Everyone will allow that this was extremely tedious. Besides this, these weekly comparisons resulted in showing that this manner of obtaining rate and height was frequently accompanied by important errors, equal to the differences which the clock would have made irrespective of the variations of the air pressure.

A second experiment consisted in locating a barometer tube on the pendulum; this tube was constructed in such a manner that its lower end was bifurcated, each one dipping into one of the cylindrical glass vessels of the pendulum bob containing the mercury. But the comparisons, extending over a period of months, showed no favorable result even then. I had started from the idea that it was inadmissible to make the tube width of such dimensions that capillarity would cease, as otherwise that part of the mercury either

escaping from the tube or rising into it would produce an injurious influence on the height of the mercury in the vessels serving for the compensation of the differences of temperature. The consequence was that although the mercury rose in the tube, it fell with great difficulty, and often only after other barometers already registered a fall of 10 millimeters or more. This also was no improvement; on the other hand, it proved to be a most decided deterioration.

Toward the end of last summer I had occasion, for the purpose of delivering a marine chronometer, to visit the Nicolaeff astronomical observatory. Professor Kortazi was so kind as to show me everything of interest to me. Among various other things, he permitted me to inspect the principal standard clock, which stands in the basement, but which is by means of electricity connected with another clock in the hall of the observatory in such a manner that this latter is compelled to always make the same oscillation with the standard clock in the basement. This is produced by the location of a polarized magnet at the lower end of the pendulum in the observatory; the pendulum, in its oscillation to the left, comes near an iron core wrapped with insulated copper wire, and as the principal standard clock sends an electric current through the insulated wire at the moment when the magnet approaches the iron core, this is in a corresponding sense magnetized and attracts the secondary pendulum. This causes the two pendulums to oscillate unconditionally uniform; which uniformity would continue even if the length of the second pendulum were shortened so much that its free oscillations would show a daily difference of several minutes' gain. Beside this, the main standard clock is by telephone connected with the hall of the observatory, and its beats are plainly audible.

My attention was principally attracted to the barometer compensation on the mercury pendulum of the main standard clock. It consists of a glass tube 15 Paris inches, 3 lines [1 meter (39.37 inches) = 3.078.44 Paris feet; 10 millimeters = 4.4330 Paris lines] long and 2 lines wide, the lower part of which is bent upward in such a manner, that the rising part, which is about 4 inches in length, forms an angle with the long limb of about 40° to 45°. This latter fact had escaped my attention, although it is the main factor in this arrangement. The tube is filled with mercury so far that an air space of about 2½ inches remains above, while in the lower limb the mercury rises to a height of about 1½ inches. Since this barometer compensation acted very satisfactory, a fact corroborated by the registers of the barometer heights and rate of the clocks, I concluded to experiment with something of this kind, adhering very closely to the several measurements. But, as previously said, I had left out of view that the short end of the tube in no manner raised again parallel to the long end, and the very natural consequence was that the whole work was entirely without those results, which I had imagined of it. Because, by bending the short limb parallel again to the long, the mercury in the tube raised or fell without producing any remarkable changes in the height of the oscillation center of gravity. Accidental large variations in the pressure of air proclaimed this soon enough in the rate of the clock. It now occurred to me to fill a tube with mercury in such a manner that it in the upper part as well as in the lower, and before it reached the curved limb, still offered sufficient play for the ordinary barometric variations. This led to the result that the variations in the air pressure influenced the rate of the clock thus that they stood almost in the reverse proportion, as no barometric compensation was introduced. I concluded from this that the bending of the small limb of the barometer on the Nicolaeff clock has not without reason the shape above described. Guided by these experiences, I then constructed my barometer so that I observed the rising and falling of the mercury in the tube, in which the mercury did not reach down to the bottom, and compare these results with those of an ordinary barometer, with the result that the variations in height above 760 millimeters stood in proportion under the quantity as 1:5. From this was to be seen that the air pressure was able only to drive the mercury upward in a definite succession; besides this, the fact was evident that the end of the tube

bent upward must be a curve, if it was to act correctly, and its shape must be within the range of calculation is not difficult.

Let us suppose that our intention is, first, to reduce the unequal rising and falling of the mercury by means of the terminal curve of this barometer to such a condition that the proportion of the rise to the fall became such as is the case with ordinary barometers; this means, therefore, when the ordinary barometer has fallen 10 millimeters or has risen by this quantity, the terminal curve of the short barometer on the pendulum must have such a form that a thorough equalization in the rising or falling mercury occurs. We would remark here that it would be advantageous if the limits in the width of the tube are not exceeded, having its interior width not over 4 mm. and not under 2 mm.

Accompanying figures show the manner of construction with sufficient plainness. In fig. 1 is seen the upper part of the tube with a width of nearly 4 mm. At the stroke, designated with 760, is found the highest end of the mercury column, for the mean barometer height. The space above this stroke is filled with air, which by the pressure of the mercury column, when the barometer is in a vertical position, is already so compressed that the mercury can in this case rise no higher. The stroke above this limit and marked 800, signifies the greatest possible height with a very high or highest barometer height, while the stroke marked with 720 shows the lowest. Fig. 2 represents the lower part of the barometer with the curve; the whole length of the latter amounts to 243 mm. The

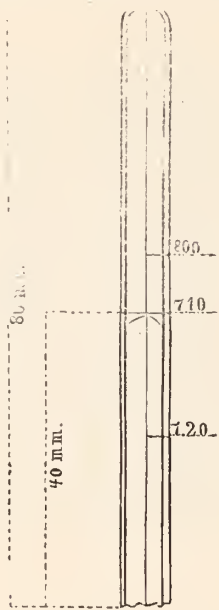

FIG. 1.

lines between the points *a*, *b* and *c*, represent the division, as specially ascertained by experience for this case. In order to find the curve also for other dimensions, do as follows: Take a tube, and pay more regard to its bore than to the exterior circumference, or length, and close one of its ends by fusion; then fill mercury into it, in such a manner, however, that an empty space of about 70 or 80 mm. remains above. Make the mercury column of such a length as you desire the barometer afterward to have. Place this tube now in a vertical position, and observe the rising and falling of the mercury column, marking the heights with ink strokes upon the tube, ascertaining these values from an ordinary barometer. An example will illustrate my meaning still better. Let us suppose there is a barometer height of 760 mm.; this is transported upon the barometer under construction, by drawing a stroke, taking the meniscus (the convexity of the mercury on top) as guide. At another time it will be observed that the ordinary barometer stood 775 mm. high, and since the new one has risen equally, you must also mark the height of the latter by a stroke. Since, now, the difference of both heights is 15 mm., it is desirable to ascertain a similar difference on the other side. It may be likely that quite a time will elapse until such a mark can be made, but when it has happened, we have three

marks the values of which are known. But these three lines will preserve no regular distance from each other, because a resistance is offered to the rising of the mercury by the air inclosed in the upper part of the tube which is overcome only in part, while its falling is accelerated by the pressure from above, in consequence of which the unequal rising and falling by equivalent pressure. These three points, however, are excellent factors for finding the required curve. In accompanying fig. 3, the line *ef* denotes the mercury column in the upper part of the tube; the three points *a b c* are those ascertained by experience, the line *bb'* signifies the distance between *a*

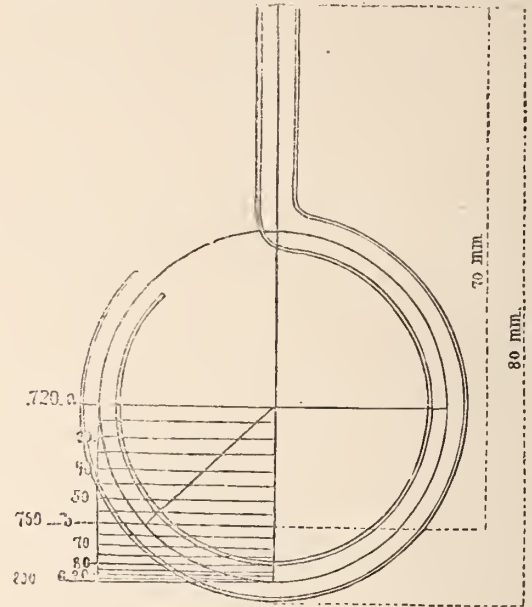

FIG. 2.

and *b*, and the line *cc'* the distance of *c* from *b*. These three points *a*, *b'*, and *c'*, are united by a part of circle, the center of which lies at *d*. The sector *gh* forms the desired curve. When, now, this part of the circle from *c'* to *a* is divided into small equal parts, and when these are united at right angles with the line *ef*, we obtain a division similar to that in fig 2, and the values of distances among each other are equal to those of the ordinary barometer. It is also evident that, for instance, in the falling of the barometer a much larger quantity of the mercury descends as by double the pressure would ascend, and the rate of the clocks would thereby not be compensated, if the curve would in this case also not render its assistance. When the mercury falls in a barometer it rises in the curve, and here it is compelled to approach in a steadily progressing increase to a straight rising line. On the other hand, by the much

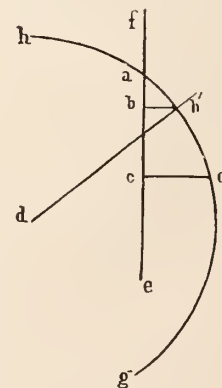

FIG. 3.

more difficult rising, the mercury runs in the curve, and approaches to a horizontal position. By this are made uniform the otherwise unequal values. It must also be mentioned that a change in the height of this barometer is produced by temperature influence, which must be met by over-compensation.

It is also necessary to add that by reason of the width of the tube bore and the thereby varying weight of the mercury contained in it, the shape of the curve may be slightly varied and no longer perfectly compensate the pendulum oscillations. This may be easily altered by shifting the barometer a trifle.

I have in the preceding abstained from the use of algebraic formulæ, in order to render it intelligent to the ordinary reader.



The following list of patents is compiled from the records of the United States Patent Office, and specially reported to THE JEWELERS' CIRCULAR.

Issue of November 26, 1889.

- 415,735—CLOCK PENDULUM.** GEORGE P. REED, Melrose, Mass. Filed May 29, 1889. Serial No. 312,560. (No model.) The salient feature of this device is a variable and adjustable cup or weight with socketed shelf or shelves in combination with adjustable balls or weights, a screw-rod and posts, a laminar ring and curve and a pendulum rod.
- 415,737—MACHINE FOR ENAMELING WATCH DIALS.** EPPA H. RYON, Canton, O. Filed Sept. 16, 1889. Serial No. 324,023 (No model.) The combination of a rotating disk adapted to receive, hold and rotate a watch dial, a plate gauge and a rest.
- 415,760—CUFF BUTTON.** MAUDE P. WOODS, Lynn, Mass. Filed July 15, 1889. Serial No. 317,577. (No model.) A cuff button comprising a head, a foot and a connecting shank, the head being provided with a swivel eye disposed in the periphery thereof, and with a hook having a U-shaped body and a shank at right angles thereto secured through the swivel eye.
- 415,817—ELECTRICAL APPLIANCE FOR WINDING CLOCKS.** FREDERIC A. LANE, New Haven, Conn., assignor of one-half to Frank E. Morgan, same place. Filed March 5, 1889. Serial No. 301,824. (No model.)
- 415,832—MANGANESE BRONZE AND ALLOY OF COMMERCE.** ALFRED H. COWLES and EUGENE H. COWLES, Cleveland, O. Filed Oct. 3, 1888. Serial No. 287,094. (No specimens.) This process consists in forming alloys of manganese and adding from a trace to five per cent. of aluminum to such alloys to increase their strength, elasticity and facility of casting and diminish their tendency to corrosion and to add to their silver-like luster and whiteness.
- 415,880—MACHINE FOR ORNAMENTING WIRE.** WILLIAM M. PATR, Providence, R. I. Filed June 10, 1889. Serial No. 313,650. (No model.) A machine for ornamenting wire, consisting in a rotating tubular arbor, a bed provided with ways extending from the arbor at right angle to its axis and revolving with the same, a slide adjustable on the bed, and a shaft supporting a milling wheel held adjustably in the slide, so that the milling wheel can be fixed at any desired angle to the axis of the tubular arbor in the combination.
- 415,956—WATCH BOW.** HERMAN T. BUCK, New York, N. Y. Filed March 8, 1889. Serial No. 302,422. (No model.) The combination, with a watch case, of a stem thereon provided with recesses adapted to receive the ends of a watch ring, a ring surrounding the stem and provided with openings through which the end portions of the watch ring pass, and also provided with cavities through which the end portions pass, and projections on the end portions arranged within the cavities.
- 415,960—WATCH CASE PLIERS.** MARTIN N. COE, Ashland, Wis. Filed June 6, 1889. Serial No. 313,334. (No model.) The jaws in these pliers have their opposing extremities struck on a circle, the first one being provided with a concave inner face and the second one being provided with a convex outer face, the latter being overlapped by the end of the first jaw and of such curve as to extend beyond the same.
- 415,969—TOOL CLAMP.** GEORGE F. HALL, Newark, N. J. Filed Aug. 16, 1889. Serial No. 320,983. (No model.)
- 415,996—WATCH BOW FASTENING.** JAMES M. CALHOUN, Plymouth, Pa. Filed Aug. 19, 1889. Serial No. 321,273. (No model.) A watch bow for stem-winding watches, consisting of a stem having socketed right-angular arms for reception of stemmed cones for securing the bow ends, the cones being secured by a sleeve inserted in the stem.
- 416,015—METHOD OF APPLYING CHARACTERS AND LINES TO WATCH DIALS.** FRANCOIS SCHMALZ, New York, N. Y., assignor to the American Waltham Watch Company, Waltham, Mass. Filed April 2, 1888. Serial No. 269,324. (No model.) This improved process of applying characters and lines to dials, etc., consists in applying to the dial a sensitized coating, exposing portions of this coating to light through a photographic negative of the characters and lines to be produced, then covering the coating with ink, then subjecting the whole to a bath of water to remove the soluble portions of the coating and the ink thereon, then drying and warming the dial to soften the ink, then while the ink is soft dusting on powdered enamel or enamel paint, which is retained only by the inked portions of the dial, and finally firing the dial to fuse the powdered enamel.
- 416,092—KALEIDOSCOPE.** CLEMENT C. CLAWSON, Newark, N. J. Filed Aug. 26, 1889. Serial No. 321,966. (No model.)
- 416,148—SECONDARY ELECTRIC CLOCK.** EASON L. SLOCUM, Pawtucket, R. I. Filed Oct. 26, 1888. Serial No. 289,246. (No model.)

Issue of December 3, 1889.

- Design Patent No. 19,468—SPOON, ETC.** WILLIAM ROGERS, Hartford, Conn. Application filed June 3, 1889. Serial No. 312,989. Term of patent 14 years.
- Design Patent No. 19,470—THIMBLE.** HENRY A. WEINMAN, Philadelphia, Pa., assignor to Simons, Bro. & Co., same place. Application filed Oct. 30, 1889. Serial No. 328,715. Term of patent 14 years.
- 416,259—KNITTED CHAIN.** WILLIAM C. EDGE, Newark, N. J. Filed March 12, 1889. Serial No. 302,990. (No model.) A knitted wire chain or belt having the ends of its wire sections turned in the same direction and substantially parallel with the edge of the belt or chain.
- 416,470—BUTTON OR STUD.** WILLIAM LOEB, Providence, R. I. Filed March 18, 1889. Serial No. 303,661. (No model.) In a detachable button

or stud, the combination, with a back plate rigidly secured to the button, a circular rib slotted on opposite points, and a post secured to the back plate provided with a curved shoe, of a spring plate, a slotted cylindrical projection on the spring plate, a winged post secured to and turning with the spring plate, and a spring constructed to enter the slots in the cylindrical rim of the spring plate.

- 416,485—SPECTACLES.** JOHN MCPHAIL, Liverpool, County of Lancaster, England. Filed July 30, 1889. Serial No. 319,160. (No model.) In spectacles, eye-glasses and pince-nez having hinged adjustable nose bearings, the combination, with these bearings of spirally-coiled wires having milled edges and retaining springs.
- 416,528—EYE-GLASSES.** CHARLES S. WELLS, Boston, Mass. Filed June 10, 1889. Serial No. 313,774. (No model.) In these eye-glasses there is combined with a pair of lens-frames a spring nose-piece for connecting the frames, a pair of clips connected with the frames, each consisting of jaws and set-screws, and temple-pieces jointed to the clips.
- 416,651—FORK.** CHARLES SPRAKE, Detroit, Mich. Filed March 22, 1889. Serial No. 304,259. (No model.) A carving fork with a guard located adjacent to the tines, these tines being adapted to move longitudinally adjacent to the guard by means of a projection.
- 416,677—JEWELRY SETTING.** WARREN HOLDEN, Providence, R. I., assignor to the Fowler Brothers, same place. Filed March 21, 1889. Serial No. 304,194. (No model.) In an article of jewelry or ornament, the combination, with the several stones provided with a contracted attaching shank, of the setting having a continuous upwardly-turned outer rim, and raised partitions which are lower than the rim and are struck up from the back of the plate to form holding pockets adapted to fit the shank of the stone.

Issue of December 10, 1889.

- Design Patent No. 19,472—BRACELET.** EDWARD P. BEACH, Newark, N. J. Application filed Oct. 16, 1889. Serial No. 327,226. Term of patent 3½ years.
- Design Patent No. 19,479—CHATELAINE BAG.** JOHN HENKEL, Hoboken, N. J. Application filed Nov. 2, 1889. Serial No. 329,084. Term of patent 3½ years.
- Design Patent No. 19,481—BUTTON.** CLAIR D. STONE, Chicago, Ill. Application filed Oct. 28, 1889. Serial No. 328,479. Term of patent 3½ years.
- Trade Mark Patent No. 17,268—CUFF AND COLLAR BUTTONS.** FRED. I. MARCY & Co., Providence, R. I. Application filed Sept. 20, 1889. Used since June 15, 1889. "The words 'The Eiffel.'"
- 416,804—CLOCK MOVEMENT AND THE LIKE.** HENRY S. PRENTISS, New York, N. Y. Filed April 3, 1889. Serial No. 305,863. (No model.) An equalizing mechanism for spring motors, consisting of a revoluble shaft, a winding arm arranged to turn about a center in line with the shaft and provided with two stops, an equalizing spring having an end attached to the revoluble shaft and one to the winding arm, an arm provided with a stop adapted to engage with the stops of the winding arm, a cam on the revoluble shaft and an arm engaged by the cam and connected with the stop-bearing arm.
- 416,831—MECHANISM FOR THE MANUFACTURE OF WATCH LIDS, ETC.** FREDERIC ECAUBERT, Brooklyn, N. Y. Filed May 8, 1889. Serial No. 310,008. (No model.) In the manufacture of watch glass bezels, the combination, with annular dies corresponding in their interior configuration to the exterior surface of the bezel, of a roller corresponding at its periphery to the recess for the glass and the reflector surface of the bezel for forming the annular recess for the glass and shaping the bezel, and a stop to limit the movement of the roller and insure uniformity in the diameter of the recess for the glass.
- 416,832—DEVICE FOR MANUFACTURING WATCH CASES.** FREDERIC ECAUBERT, Brooklyn, N. Y. Filed May 20, 1889. Serial No. 311,448. (No model.) In this device is combined with an annular die having a screw-threaded interior surface, of a roller to act within the sheet metal article and press the same outwardly into the screw-thread of the die to produce an external screw-thread on the article without corresponding internal indentations.
- 416,835—DIE FOR WATCH CASES.** WALTER H. FITZ GERALD, Brooklyn, N. Y., assignor to Frederic Ecaubert, same place. Filed July 18, 1889. Serial No. 317,884. (No model.) The inventor here combines with the split chuck having a tapering exterior surface a compressing shell screwed upon the same and acting to close the split chuck, such split chuck having an internal die portion containing offsets, or ornaments, or both, corresponding to the surface of the watch case bezel, back, or ring, to be produced within such die portion.
- 416,857—FRAME FOR EYE-GLASSES.** LOUIS RIEMENSCHNEIDER, New York, N. Y. Filed Aug. 9, 1889. Serial No. 320,219. (No model.) A wire lens-frame provided at one end with a post having a recess at its inner end and provided on its other end with a hub fitting into this recess, the post and hub having longitudinal apertures, that of the hub being threaded, wings on the outer ends of the post, a nose-rest and a bow-spring placed between the wings, and a screw passed through apertures in the spring, nose-rest and post, and screwed into the aperture of the hub.
- 416,871—OPERA GLASS HOLDER.** JOHN S. SPENCER, New York, N. Y., assignor of one-half to James E. Spencer, Brooklyn, N. Y. Filed Nov. 30, 1888. Serial No. 292,197. (No model.) The holder for opera glasses, consisting of arms having integral therewith ears, which at their ends overlap each other, the lower ends of the arms diverging from each other, combined with the screw, whose head is inclosed on opposite sides by the ears, which are secured thereto by a rivet, the handle and the internally-threaded head, secured in the handle in position to receive the screw and move against the lower diverging ends of the arms.
- 416,887—BRACELET.** WILLIAM H. BALL, Newark, N. J. Filed July 26, 1889. Serial No. 318,756. (No model.) In a bracelet composed of two hollow wire segments hinged together at one end, the combination, with the segment provided at its mouth with catch-piece and intermediate to the catch-piece and the hinge with a slot, of a re-enforcing patch applied about the slot, and a segment provided with a spring-guard secured therein at one

end, and its other end provided with a lug and projected into the mouth of the segment.

- 416,932—**BUTTON HOOK.** GEORGE W. MABIE, Brooklyn, N. Y. Filed Feb. 23, 1889. Serial No. 300,839. (No model.)
- 416,947—**THERMOSTAT.** WILLIAM P. POWERS, La Crosse, Wis. Filed Jan. 26, 1889. Serial No. 297,626. (No model.)
- 417,016—**SETTING FOR COINS.**—THOMAS F. GAYNOR, Louisville, Ky. Filed May 25, 1889. Serial No. 312,168. (No model.) A coin-setting of annular shape provided with a concentric groove, an open joint, and a fastening, in combination with a concentric-grooved jointed bushing, the walls of which consist of series of prongs.
- 417,080—**SPECTACLES.** PETER PECK, Southbridge, Mass. Filed July 24, 1889. Serial No. 318,506. (No model.) The combination of the spectacle frame, the hinged spring bows, the concavo-convex temple plates, having inwardly-bent parallel side flanges, and the removable elastic temple cushions overlapping the flanges.
- 417,166—**TICKET HOLDER.** JOSEPH GEISENHEIMER, New York, N. Y. Filed Sept. 21, 1889. Serial No. 324,627. (No model.)

Issue of December 17, 1889.

- Design Patent No. 19,486**—**BADGE.** WILLIAM P. DANIELS, Cedar Rapids, Iowa. Application Filed Nov. 5, 1889. Serial No. 329,370. Term of patent 14 years.
- Design Patent No. 19,488**—**SPOON.** AUSTIN F. JACKSON, Taunton, Mass., assignor to the Reed & Barton Corporation, same place. Application Filed Oct. 21, 1889. Serial No. 328,721. Term of patent 14 years.
- Design Patent No. 19,497**—**HANDLE FOR SPOONS, ETC.** GEORGE W. SHIEBLER, Brooklyn, N. Y. Application Filed Sept. 12, 1889. Serial No. 323,779. Term of patent 7 years.
- Design Patents No. 19,498 to 19,503, inclusive**—**HANDLE FOR SPOONS, ETC.** GEORGE W. SHIEBLER, Brooklyn, N. Y. Applications filed Nov. 4, 1889. Serial Nos. 329,226 to 329,231, inclusive. Term of patent 7 years.
- Design Patent No. 19,504**—**CANDY OR SUGAR TONGS.** AMARIAH G. COX and ORLANDO J. BUCK, Chicago, Ill. Application filed Oct. 18, 1889. Serial No. 327,463. Term of patent 7 years.
- 417,226—**MACHINE FOR SPINNING METALS INTO IRREGULAR SHAPES.** JOSEPH BROWNING, Philadelphia, Pa. Filed July 30, 1889. Serial No. 319,174. (No model.)
- 417,377—**MACHINE FOR POLISHING WATCH PINIONS.** CHAS. V. WOERD, Waltham, Mass.; Daniel O'Hara administrator of said Charles V. Woerd, deceased. Filed Nov. 9, 1885. Serial No. 182,317. (No model.) In machines for polishing or cutting pinion, embracing in their organization a pinion-leaf polishing or cutting tool capable of a reciprocating radial movement as to the axis of the pinion, and a pinion rotator capable of being moved into and out of the spaces between the leaves of the same pinion, and otherwise, both of suitable construction and operation, in combination, a continuously-rotating cam wheel having equidistant cam projections and supporting the tool, mechanism for rotating the cam wheel, a continuously-rotating dog to operate on the moving pinion carrier, provided with equidistant pockets, each suitably adapted to receive and hold a pinion for being polished or cut and rotated, an index wheel, connected to and operating the pinion carrier and having equidistant notches or teeth mechanism to intermittently rotate the index wheel, a continuously-rotating dog to actuate the mechanism for rotating the index wheel, and a train of gearing composed of two gear wheels rotating as one, a gear wheel fixed on a shaft and meshing one of the gear wheel, and another gear wheel having an adjustable support, a shaft having cam wheel fixed thereto, and a gear wheel carrying a rotating dog.
- 417,501—**WATCHMAN'S ELECTRIC TIME DETECTOR.** HENRY L. NORTON, Ukiah, and FREDERICK W. COOK, San Francisco, Cal. Filed April 10, 1889. Serial No. 306,721. (No model.)
- 417,569—**MEANS FOR SECURING FINGER RINGS.** AUGUST F. MARGLETH, Springfield, Ohio. Filed July 29, 1889. Serial No. 319,032. (No model.) This device consists of a chain attached to a ring, a chain encircling the wrist having one of its ends attached to an open sleeve and the opposite end extending through the sleeve and made adjustable therein by means of a spring latch and pin on the latter engaging a hole in the sleeve and one of the links of chain therein.
- 417,574—**SCREW-CUTTING TOOL.** KARL MISCHKE, New York, N. Y. Filed Feb. 28, 1889. Serial No. 301,553. (No model.) The combination, with a tubular stock, fulcrumed and spring-actuated die-levers having dies at their front ends, a sliding sleeve located on the rear part of the stock and provided with a conically-tapering front end, a shifting screw in the stock connected to the sliding sleeve, and an adjustable stop-rod passing longitudinally through the stock, so as to control the length of shifting motion of the sleeve.
- 417,615—**MACHINE FOR GRINDING LATHE-BEDS.** AMBROSE WEBSTER, Waltham, Mass. Filed Jan. 30, 1889. Serial No. 298,091. (No model.) In a machine for grinding lathe-beds, in combination, a carrier for the lathe-bed to be ground, and appliances held on and for securing it to the carrier, consisting of a swinging stirrup-arm at one of its ends for leveling it on the carrier, and jaws at its opposite ends, each adapted to be engaged with and disengaged from and to draw it down onto its carrier.
- 417,640—**JEWELER'S TRAY.** LUDWIG HIRSCH, New York, N. Y. Filed Apr. 6, 1889. Serial No. 306,197. (No model.) In this jeweler's tray there are longitudinal partition strips and detachable spring clasps applied to the ends of the strips and provided with a spring body extending at both sides of the strips, so as to exert a spring pressure on the side walls of the tray or drawer and hold the strips in position.
- 417,644—**CANNON PINION FOR WATCHES.** GEORGE E. HUNTER, Elgin, assignor to the Elgin National Watch Company, Chicago, Ill. Filed Apr. 24, 1889. Serial No. 308,367. (No model.) In combination with a cannon pinion and an arbor, a sleeve which has formed in its sides two longitudinal slots, one of which extends throughout the length thereof and the other extends but partially through its length, these slots constituting of the sleeve a spring adapted to unite the pinion and arbor.



At the meeting of the Executive Committee of the Jewelers' League, held on Friday, December 6th, there were present Messrs. Howe, Bowden, Greason, Jeannot, Houghton and Sexton.

Five requests for change of beneficiary were granted. Proof of the death of Henry Horwitz was presented and the Secretary was instructed to pay the beneficiary the full amount of the claim. Dr. D'Ancona was appointed Examining Surgeon of the League for San Francisco and Dr. C. O. Wright for Cincinnati.

Two applications for membership were referred for investigation and the following gentlemen were admitted to membership:

A. G. Earle, Colorado Springs, Col., recommended by Frank Davenport; Julius P. Whitney, Tyler, Tex., recommended by John W. Steele; E. R. Seutter, Jackson, Miss., recommended by M. Lissauer; Harry H. Test, Houtzdale, Pa., recommended by W. H. McCausland; R. N. Johnquest, Ansonia, Conn., recommended by D. Untermeyer; Geo. I. Johnson, Ridgefield, Conn., recommended by Alexander Weed; Chas. M. Piccard, Sioux City, Ia., recommended by C. C. Offerman; Leon Carrau, San Francisco, Cal., recommended by P. A. Shattuck and G. A. Simons; Samuel Mayer, Denver, Col., recommended by S. Bohman and H. A. Barmeier; Frank J. Hooper, Aspen, Col., recommended by S. Bohman and H. A. Barmeier; Orlando Rose, Chicago, Ill., recommended by J. B. Ridgway; Rudolph Kohlhepp, Boston, Mass., recommended by H. Schreiber and T. Clarkson; Julius Woywoth, New York City, recommended by S. Bass and G. Holland; Leopold Heizberg, New York City, recommended by W. H. Tarlton; Geo. E. Marcus, New York City, recommended by John R. Greason.

The Jewelers' Security Alliance

President, DAVID C. DODD, JR.

First Vice-President, AUGUSTUS K. SLOAN.....Of Carter, Sloan & Co.

Second Vice-President, HENRY HAYES.....Of Brooklyn Watch Case Co.

Third Vice-President, DAVID UNTERMAYER.....Of Keller & Untermeyer.

Treasurer, CHAS. G. LEWIS.....Of Randel, Baremore & Billings.

Secretary, GEO. H. HODENPYL.....Of Hodenpyl & Sons.

EXECUTIVE COMMITTEE.

J. B. BOWDEN, *Chairman*.....Of J. B. Bowden & Co.

C. G. ALFORD.....Of C. G. Alford & Co.

N. H. WHITE.....Of N. H. White.

F. KROEBER.....Of F. Kroeber Clock Co.

SILAS STUART.....Of Silas Stuart.

H. H. BUTTS.....Of H. W. Wheeler & Co.

EXAMINING FINANCE COMMITTEE.

J. P. SNOW.....Of G. & S. Owen & Co.

HENRY ABBOTT.....Of Henry Abbott.

For further information, Application Blanks for Membership, By-Laws, etc., Address
P. O. Box 3277. 170 Broadway, New York

The regular monthly meeting of the Executive Committee was held at the Alliance office on the 13th inst. There were present President David Dodd, Jr.; Vice-Presidents A. K. Sloan and David Untermeyer; J. B. Bowden, Chairman; Messrs. White and Butts, and Geo. H. Hodenpyl, Secretary.

The following have been admitted to membership: E. Bennett, 1294 Broadway, N. Y. City; Edwin Bixby, cor. 3d and Center Sts., Ironton, Ohio; Ferdinand H. Baum, 3028 State St., Chicago, Ills.; Hiram F. Burgess, cor. Main and Bridge Sts., Fairfield, Me.; James McConahy, 20 E. Washington St., New Castle, Pa.; Tom. N. Donnelly & Co., 118 Dearborn St., Chicago, Ills.; S. Carey Frantz, 135 Main St., De Graff, Ohio; C. E. Gifford & Co., 1 S. Main St., Fall River, Mass.; Charles S. Hirst, 631 Chestnut St., Philadelphia, Pa.; James K. Leman & Son, 515 Fourth Ave., Louisville, Ky.; Phillips & Armitage, 6 E. Third St., Jamestown, N. Y.



Improved Stem-Winding and Stem-Setting Watches by Isaac Goddard.

THE necessity of reliable standard time to govern the complicated movements of the multitudinous trains of our marvellously growing railroad system has created a demand for absolutely accurate and reliable timepieces, for use not only at the great railroad centers and principal starting points of trains, but also among all conductors, engineers and others who are in any way responsible for the moving of trains, and must, therefore, be provided with watches capable of running within prescribed limits of variation.

While it is possible, and even may be common, for watches to run with very uniform rates, either losing or gaining in very small amounts, it is not practical for the ordinary watch wearer to make the needful allowance or computation each day to ascertain the exact second by standard time. Consequently the simpler and safer way is to have one's watch periodically set exactly by the reliable standard clock, which is daily compared with and brought to exact conformity to observatory time, now daily distributed by telegraphic signals. Recent improvements in the construction of watches provide for winding and setting through the case pendant, and dispense with the lever formerly used in stem-winding watches to disengage the winding mechanism and engage the hand-setting. This form of

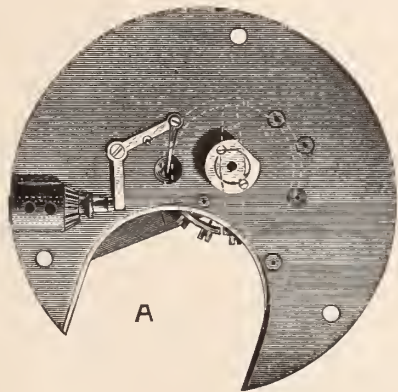

movement construction has allowed the use of cases made in such form as to render them more thoroughly dust-proof than cases of ordinary construction. But the advantage of tightness so gained has of necessity made it more difficult to gain access to the second hand of the watch for the purpose of accurate setting.

To obviate this disadvantage, and to provide a simple, safe and reliable means of setting watches to the exact second without requiring immediate access to the second hand, Isaac Goddard, of the firm of Goddard & Moses, Richmond, Va., has patented a device for instantly stopping the movement of the train of the watch, and also of setting the hands at the desired point, and then again starting the watch at the instant desired.

The accompanying illustrations show the device as applied by the American Waltham Watch Co. to their 18 Size Full Plate Pendant-Setting watches, and will be understood by help of a few words of explanation. The large cut *A* shows the underside of the top plate together with the winding pinion, and the push pin projecting through it and in position for setting the hands. It will be observed that one end of an angular or "bell crank" lever is in contact with the little push pin, and the other end of the lever carries a delicate spring arm

which curves down and projects through a conical hole in the plate and impinges upon the edge of the balance rim; a very slight touch suffices to immediately arrest the movement of the balance. When, after setting the minute hand at the desired point (of course a fraction of a minute in advance of the Standard Clock), the exact second for starting the watch is reached, a slight push on the watch crown drives the push pin inward and it causes the angular to swing on its fulcrum, and so carries with it the little brake spring, which slides up the inclined sides of the hole, and out of contact with the balance, which instantly resumes its vibrations. A half

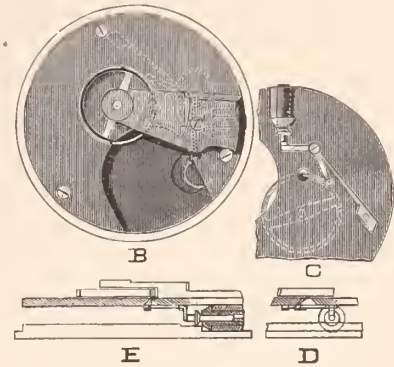

turn of a little screw, provided for the purpose, will at any time put the mechanism out of operative position if desired.

The smaller cut *B* shows a top view of the top plate, and also a view *C* of the underside of the same. The two sectional views *D* and *E* show the conical hole through which the little brake spring projects when in contact with the balance.

While the foregoing describes what is regarded as the simplest and best form of applying the device, the device has been applied to make contact with the fourth wheel with perfect success. So far as this invention has been seen by the trade, it has been most highly commended, and it is probably only a question of time as to its general adoption.

An Improved Watch Bow.

AN IMPROVEMENT in pendant bows upon which Amos E. Keepert, Reading, Pa., was recently granted letters patent, contains a distinctively novel feature. The bow is more particularly adapted to watches provided with a pendant wind and set, the setting being accomplished by pulling the crown outward before rotating it.

The bow ordinarily used being merely a cut ring, sprung into the pendant, has been found to be occasionally objectionable in pendant



setting watches above referred to. The watch chain swivel is apt to catch under the crown in pulling the watch from the pocket, and to move it into the position where it engages the hands, thus interfering with the proper working of the watch. Moreover, when the stem is intentionally pulled out it is sometimes forgotten to be returned, with the same bad effect. The main object of the invention is to

avoid these troubles, to effect which the bow, as is seen in the diagrams, is provided with a cross-bar which will bear upon the top of the crown, so as to return it to its normal position when the bow is turned into the same plane as the watch, affording at the same time a limited opening for attaching the chain, the swivel of which being prevented from touching the crown.

This construction is also advantageous even for ordinary watches, because the wear upon the bow does not weaken it so as to render the pivoted ends liable to be pulled out of their bearings in the pendant, it being greatly strengthened by the cross bar referred to.

The drawings, which readily explain the device to the reader, show bow attached to a pendant setting watch of the form described, fig. 1 being a front elevation and fig. 2 an end view, showing the bow in section and inclined to the plane of the watch.

A New Pendulum Adjusted to Temperature.

IN THE November issue of THE CIRCULAR was described a compensated clock pendulum invented by George P. Reed, of Melrose, Mass. Last month the same inventor was granted letters patent for additional improvements in clock pendulums, for the facilitating and obtaining a more accurate adjustment to the different degrees of temperature.

The drawing shows a sectional view of the invention.

W represents a variable and adjustable weight, consisting of a

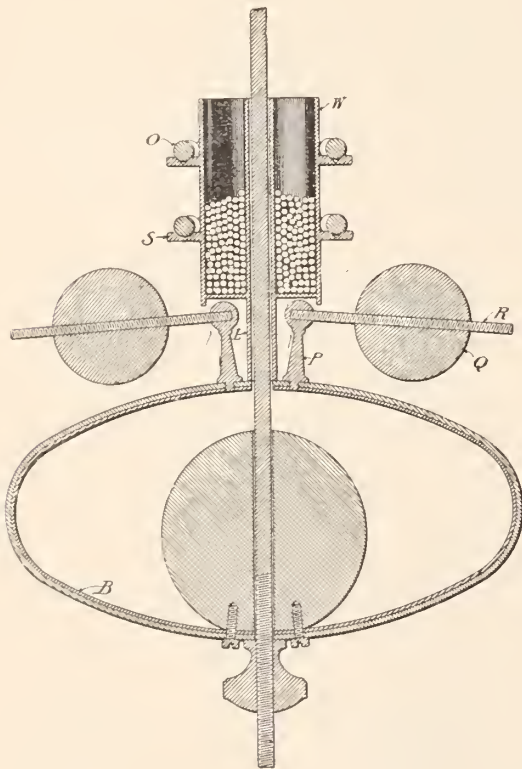

cylindrical or other form of cup, encircling the pendulum rod, to be filled with gunshot or other movable material, with or without its lower portion L made smaller and elongated, if requisite for convenience of space.

The laminar ring or curve B is fitted, where required, near the free-acting ends with posts P, which have screw rods R connecting same, as shown, upon which move, by turning, the adjustable balls or weights Q. The W weight rests upon and is supported by the laminar curve B as the latter is affected by the different degrees of temperature. S represents a shelf running around and attached to the weight W, to hold bullets, as shown in drawing, or other removable weights.

To obtain a correct adjustment to heat or cold, the inventor

claims that it is only necessary to take from or add to the weight either inside or outside the cup, or turn the weights Q upon the screw rod R, using one or all of these devices for the purpose.

New Tools for Watchmakers.

Among the new tools for watchmakers which have recently been put upon the market are the following: A combined screwdriver and tweezers, with which a screw can be picked up and turned in without changing tools. A screw stand is sold with it. Another, Smith's patent staking-tool anvil and screw holder (fig. 2), is very handy for removing and putting on rollers, putting the hairspring collet on the balance staff, or for riving in bushings. Four punches and six stubs which come with tool will prove useful for a variety of purposes. Fig. 3 illustrates Douglas' patent combined



FIG. 1

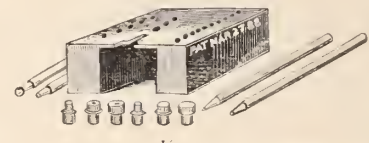

FIG. 2

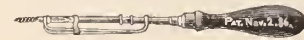
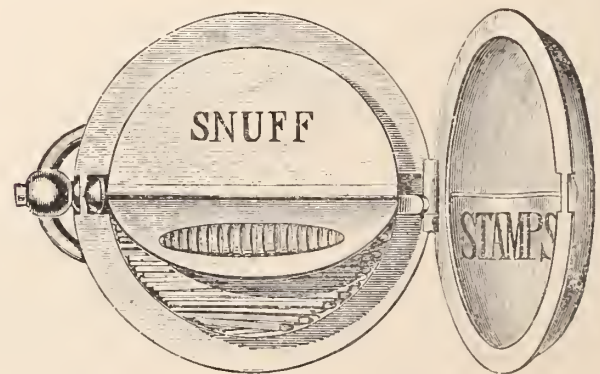

FIG. 3.

screwdriver and holder. It will hold a screw in the most difficult places and drive it in at the same time, and is so constructed that the holder slides back out of the way as the screw is driven in. The wire loop readily adjusts itself to many sizes of screws and will not get out of order. It is claimed to be the simplest and most durable tool of the kind ever invented. These tools are manufactured by O. W. Bullock & Co., Springfield, Mass., who have devoted almost their undivided attention for the past fifteen years to the production of fine tools for watchmakers, jewelers, opticians, etc.

Receptacle Watch Case.

Under the title "Eclipse" (registered No. 133,637), Messrs. C. Timings & Son, of Spencer Street, Birmingham, have placed upon the market another novelty on the lines of their well-known collapsible drinking cup, as an adjunct to the "Albert" chain. Like the drink-



ing cup, this combination is contained in a watch case, but it has doubtless a greater popularity than was accorded the former, for whereas the drinking cup is only useful to travellers and tourists, the "Eclipse" combination will be useful to all on all occasions. The receptacles in the box are for matches and snuff (for which might be substituted smokers' requisites in the shape of cachous, etc.) The cover contains pockets for stamps and railway tickets. The accompanying cut renders a further description unnecessary, but it

may be added that the cases are made in metals, to resemble gold and silver, and are warranted to keep their color, and wear through alike.—*Watchmaker, Jeweler and Silversmith.*

The Spencer Opera Glass Holder.

PERHAPS no device in the line of optical goods, aside from the staple manufactures, has achieved such a flattering amount of popularity as has the opera glass holder. Almost every jewelry establishment, however small, carries them in stock, and the lady of taste who does not possess one or more, is an exception to a general rule.

Several parties have, during the past two years, been granted patents on devices in connection with such holders, the latest being John S. Spencer, of the Spencer Optical Mfg. Co, New York, who on Dec. 10, received letters patent on improvements which contain many noteworthy features. The invention briefly, consists of a handle composed, preferably, of telescopic sections and having at one end a pair of arms adapted to clasp the screw-cylinder between the plates connecting the tubes or cross-bar of the glass the purpose

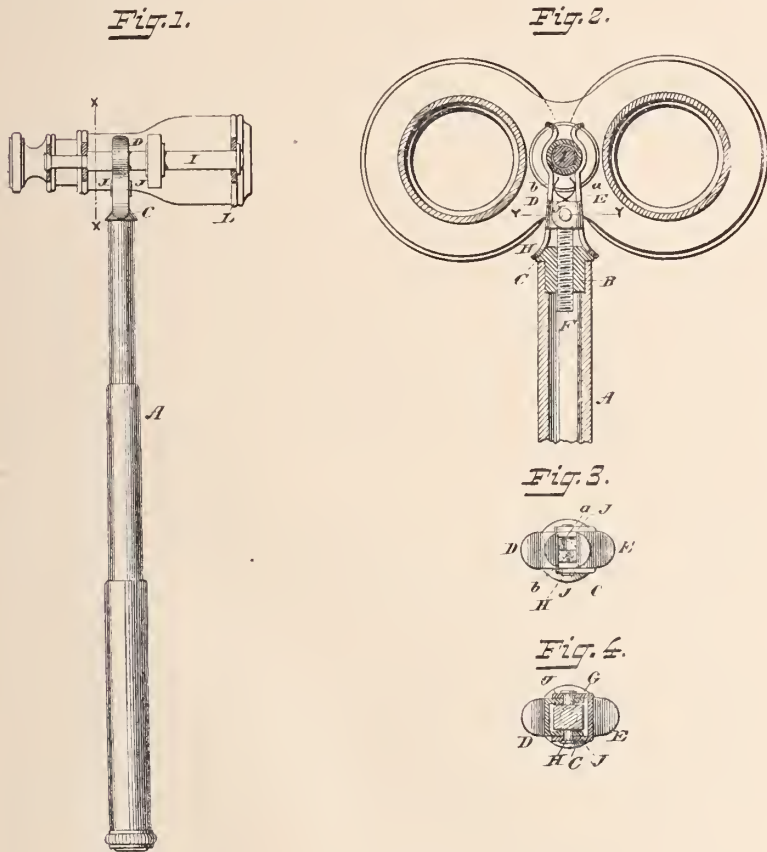

being to enable the user to hold the glasses to the eyes without unduly elevating the arm.

In the upper end of the handle is secured the internally threaded nut B, having a convex head C, whose tapering surface, operating as a wedge, performs the functions of spreading the lower ends of the arms D, E, apart. These arms are suitably conformed at their upper ends to clasp the screw-cylinder or cross-bar I of the opera glasses, and are pivoted to G, the head of threaded screw F. They are kept normally separated from each other by small leaf springs, a, b.

In the employment of the holder, the upper ends of the clamping arms D, E, are slipped over the screw-cylinder I, or the connecting bars or plates L of the opera glasses, and then caused to firmly hold the same by rotating handle A, which has the effect of chering the nut B upward on the screw F, and thereby causing the convex surfaces of the head C to force the lower ends of the arms apart and closing in the uppers. A reverse rotation of the handle loosens the clasps.

By means of the device, the user is enabled to firmly clasp the opera glass while the handle is at any desired angle, and the connection is positive, and so secure that the glasses are prevented from slipping off. This latter fact will be understood, when it is remembered that the convex head C operates as a wedge and can not slip from its position in contact with the lower diverging ends of the arms, except when the handle A is voluntarily rotated. This is a most valuable feature as it is essential in this class of holders that the glasses should be firmly held since, owing to their form and weight, they would be likely to lose their position.

The device may be applied to articles other than opera glasses, and Mr. Spencer reserves the right for doing so. The Spencer Co. commenced making this holder one and a-half years ago, but have since effected several improvements, the above among others.

Opals for a Song.

SEÑOR José Gonzales Cosio, brother of the governor of Mexico, is the owner of six of the finest opal mines for which the state of Queretaro, Mexico, is noted. Only one of the mines is now being worked, and about one hundred men are employed digging out the opal-bearing rock. The mines are located about twenty-five leagues from the city, the ore being brought to Queretaro on the backs of mules, to the residence of Señor Cosio, who personally superintends the polishing of the stones, employing about twenty skilled Mexican lapidaries.

The profits from these mines are large, owing to the fact that the labor employed in the mines is paid at the rate of only twenty-five cents per day, and the polishers receive only about seventy-five cents per day.

The mines can only be reached by a two days' journey on horseback from Queretaro, but a visit will repay the time spent. The stones are found in a peculiar rocky formation that very much resembles Tennessee marble, but which at once suggests volcanic origin, as the stone is thickly interspersed with crystallizations and strange looking volcanic glass.

The first layer of opal-bearing rock is found on the surface of the ground, and is generally about five feet thick. This is followed by a layer of earth of about the same thickness, and is in turn succeeded by another stratum of opal-bearing rock, and so on for many feet in depth. Many handsome stones are ruined by the blasting process, but this cannot be avoided. The stones are sold to the curiosity dealers in the capital and to the many tourists who stop over in Queretaro for the purpose of seeing them.

The common and generally worthless stones are bought by the native boys, who offer them for sale in the Central Railroad station, to tourists who allow themselves to be nicely gouged by these tricksters, so anxious are they to secure the stones.

A very handsome stone can be purchased for \$5, and the prices range from five cents to \$50. Señor Cosio has a magnificent collection of them at his home, and recently sent a lot valued at \$5,000 to the Paris Exhibition.

It is true that the stones, as compared with the Hungarian, are not very valuable, yet many very handsome ones have been found, some of which brought as high as \$200 each. The owners of any of these mines state that they will gladly give fifty per cent. of the profits to anyone who will take the trouble to develop them.

"A WATCH manufacturer offers his daughter in marriage (100,000 francs dowry) to the case-maker who shall construct the lightest gold watch case. Competitors to address to the office of *l'Almanach des Horologers*, St. Imier." In a foot note to the above the editor of *l'Almanach* expresses the hope for the victor that his wife will be less light than his cases.



[FROM OUR SPECIAL CORRESPONDENT.]

A "BOOM" IN THE ENGLISH JEWELRY TRADE—PRICES FIRM IN THE DIAMOND MARKET—EIFFEL TOWER IN DIAMONDS—FALL NOVELTIES IN THE LONDON SHOPS—RUMORED REVIVAL OF CAMEOS AND CORAL.

LONDON, December 10, 1889.

There are many things American in which I am always greatly interested, and many phases of your business habits from which I have learned a great deal. This is not flattery, but merely a prelude to the statement that I feel bound to make, that there are some 'things American' that I do *not* like. Amongst the latter is the remarkable freedom with which you coin words and the rapidity with which they become recognized as parts of your language. Notwithstanding my dislike to some of your current expressions, I confess that if I wanted to describe the present condition of our British jewelry trade in the shortest manner I should borrow one of your words and say there is just now a "boom" in our jewelry and kindred industries. I have never yet heard this expressive term applied to those trades, and perhaps I am philologically wrong in so applying it, but as I am writing for American and not British readers they will understand my meaning. However, whatever word may be used to indicate it, the fact remains that we have now a decided spurt in our business—something more than an improvement in trade, for it amounts in some departments to such an influx of orders that there is a difficulty in finding workmen enough to execute them. It is a very encouraging state of things and I am inclined to think that it will last. This is not the opinion of all, but I am guided by the general state of the trade of the country and my experience is that our manufacturers are sure to participate in it. The prospect is a better one than I can remember for nearly a dozen years and the realization of it, or the spoiling of it, will rest entirely with the manufacturers and wholesale dealers themselves. My only fear is that by manufacturers forcing sales, the retailers (storekeepers) may be overstocked and then surplus stocks will be injudiciously disposed of and the market disorganized as it has so often been before. If the trade of the present season is wisely conducted and good discretion is exercised in preparation for the Spring trade I shall be able to report a most healthy trade for the whole of the coming year.

Attention has been largely directed to the condition of the silver market. The price of silver has always a perceptible influence on the trade of the world. That price has improved much recently and will no doubt continue to do so. The improved trade of the country has caused an increased demand for silver coins and there is some talk of our Chancellor of the Exchequer increasing the issue of the larger silver pieces.

The continued advance in the price of diamonds is sure to have its effect on our mounters of precious stones. It is said that the rapidity of the recent advance is attributable to the "corner" in diamonds of which there have been many rumors. Of course there are some fortunate dealers and perhaps a few more fortunate manufacturers who have greatly profited by the advance in the value of the *stocks they held*. But the advanced price is a serious matter to those who have to buy for present use. Within reasonable limits the advance will strengthen the trade. The syndicate has been able to limit the supply and I hear that the lapidaries of Amsterdam are suffering much on account of their inability to obtain work owing to the scarcity of rough stones. While on the subject of diamonds, I may mention one of the most unique collections of them I have ever seen. This is a model of the now famous Eiffel Tower, in diamonds. I saw this on the first day of its exhibition in London, at the Hanover Gallery, New Bond street. It is more complete than said so called

models usually are, as the details of stairs, lifts, offices, etc., are all worked out. The height of model is a little more than one yard, or about one three hundredth part of the original. It is said that there are 40,000 precious stones used in its construction and that these stones if placed edge to edge would reach to the first platform of the real tower. The lamps are represented by beautiful pearls and even the flag at the top is made up of sapphires, diamonds and rubies. This model, like its original, is lighted by electricity, a spark of which illuminates the light house at the summit. The value of the stones used in this resplendent reproduction is said to be upwards of £120,000.

There are some original designs in fancy articles to be seen in our better class shop windows—Indeed so far as my observation goes there is far more originality to be met with in fancy goods than in articles of utility. It looks as if our dealers had been patronizing French manufacturers more than usual. The French do certainly excel in *bijouterie* and some of the novelties for this season are quite characteristic of them. There are some pretty arrangements of birds' heads and necks reproduced in colored enamel and gemmed and intended for brooches or fasteners for jackets, etc. One of the most realistic is a bright-hued parouquet perched on a gold bar with the head looking over the shoulder and studded with diamonds, rubies, etc., and arranged as a brooch. These are all fine specimens of the jewelers' art in this special application of it.

The taste for putting tiny watches in the most unlooked for places, is increasing rather than diminishing. These watches are now put at the top of one side of note books and letter cases. This combination may, perhaps, form a novel present, but I cannot see what other useful purpose it can serve. There are innumerable devices in purses with ornamental watches set in and gemmed. One is in a chain work of tiny sequins and under the arch of the clasp is hidden away the little time-keeper, sparkling with diamonds or other stones. I think the fashion for enamel work will be revived. It has never altogether lapsed, but it has been greatly neglected by our manufacturing jewelers. My impression is that if they will only produce some pretty things in that line, there will be a demand for them. Brooches are now much in vogue again. They lend themselves continually to the enamellers' art. Among the new patterns of brooches I have seen, I notice that oval shapes predominate. There are some very pretty oval shapes with diamond and moonstone work, that are full of taste and are likely to become popular. These better class goods will do much to cause the oval shape to become fashionable.

Our ring trade is very good.—Diamonds are used and seen to the greatest advantage. Of other stones, rubies and amethysts are much used; white emeralds and opals are seldom met with.

As the result of the more frequent visits of our large wholesale houses (jobbers) to Paris, cameos and coral are again prominent, and I should not be surprised to find them once more taking a front position in our own market. If we are to introduce French styles it will be necessary to imitate French producers. I would rather see our manufacturers cultivate creative than imitative ability. Taken as a whole our men are good workers, but not good designers. We are not as a nation (in the jewelry trade, at least,) artists. Steps, however, are being taken to remedy this defect, and our apprentices are to be required in future to attend art schools until they are nineteen years of age, and inducements will be held out to them to attend even after that age. Art schools being opened in our manufacturing centres, it is more than probable that the next generation of British artisans will include many true artists amongst a crowd of better workmen.

VIGILANT.

M. Emile Vanderheyem, the well-known diamond expert, died suddenly during the night of the 18th of November. He was only fifty-six years old. It was he whom the French government chose, together with M. Bloche, to superintend the famous sale of the Crown Diamonds.



TRADE GOSSIP.

—Gold pens, pencil cases and novelties are to be seen in great variety at the salesrooms of Ed. Todd & Co., 44 East 14th street, New York.

—Charles Cook, traveler for many years for F. M. Whiting & Co., silversmiths, North Attleboro, Mass., severed his connection with that firm on Dec. 13.

—On Dec. 31, August C. Morck, Jr., the well-known optician and jeweler of Warren, Pa., was united in marriage to Miss Anne Lee Chambers, of Oil City, same state.

At Ipswich, Mass., on December 17, Daniel F. Appleton, widely known as a member of the firm of Robbins & Appleton, was united in wedlock to Miss Susan Cowles, daughter of the Rev. John P. Cowles, of Ipswich.

—Wm. Folkart, of 4 and 6 John street, New York, invites the trade in city and country to look at the quality and price of the initial and seal rings made by him. In the line of diamond mountings he is prepared to meet any competition.

—Through the Stationers' Board of Trade, the following subscriptions towards the World's Fair guaranty fund were given: Edward Todd & Co., \$250; Aikin, Lambert & Co., \$250; D. F. Foley & Co., \$250; Paul E. Wirt, \$250; Mabie, Todd & Bard, \$250.

—Stephen G. Wood, whom everybody has known during the last quarter of a century as a trusted employee of E. Ira Richards & Co., North Attleboro, Mass., has entered upon a new term of service, this time with E. I. Franklin & Co., same place. He will take charge of the chain department.

—The account book published by H. W. Pamphilon, 30 Bond street, New York, advertised in another column, is a good thing. Some plan by which the amount of business done is constantly kept before one is needed by every dealer. We advise dealers to write for free sample sheet and examine the advantages of this book.

—E. A. Haldimann, jobber of American watches, of 3 Maiden Lane, New York, is not one of the complaining kind. He reports a very satisfactory trade for the Fall, and informs us that he has made large sales of the Standard low price movements in nickel, 18 size, which he says is one of the best selling watches in the market.

—Wiggers & Froelick, manufacturers of jewelry cases, 60 Nassau street, New York, and also one of the oldest and most reliable firms in that line of business, report a very satisfactory season's business. Their great study is to make every possible improvement in sample cases and trays for the trade, and in this their extensive business is the best evidence that they have succeeded.

—In calling attention to the advertisement of Henry Goll & Co. in last month's issue, we may have conveyed the impression that they were engaged only in the repairing of watch cases. While the repairing of gold or silver cases, no matter how badly damaged they may be, is an important branch of their business, yet the firm are largely employed in making special orders for the trade. Their prices are very low, and their work excellent.

—Fred Derbyshire, of the American Watch Tool Co., has just received his present of ten days' pay, due on the completion of his fifteen years' service in their employ. The practice of this company is to pay the above amount to employees on the completion of both ten and fifteen years' continuous service. They have already paid ten workman who have been in their employ ten years. Mr. Derbyshire is the first who has finished the fifteen year term.

—The Pairpoint Manufacturing Co., New Bedford, Mass., enters upon the new year with flying colors, having passed through the most successful season in its history. They are making a specialty of fancy hollow ware, such as lamps, cracker dishes, etc., of delicately tinted glass neatly mounted in plate. These goods are attaining a remarkable popularity. Their line of engraved and gilded flat ware is also very complete. A new departure which they recently made in manufacturing their own cases has proved successful beyond their expectations, and they now have quite a busy little shop pushed to its utmost to supply their wants in this line. Mr. Sperry, formerly with C. Rogers & Bros., of Meriden, has just engaged himself with the company as superintendent. He will be a valuable acquisition, as he is considered one of the most experienced men in the country in all the details of plated ware manufacture.

—Stern Bros & Co. distributed 80 turkeys among the employees of their factory on Christmas day, an act of generosity and cordial feeling on their part that is worthy of imitation in the trade.

—The following are the resolutions adopted by the Retail Jewelers' Association of Philadelphia, in reorganizing it as a State instead of City institution:

Whereas, Almost daily combinations of various kinds are being formed, both in and out of the trade, to the great detriment of the retail jeweler; and

Whereas, We find our business slipping away through the encroachments of outsiders and those manufacturers and jobbers who persistently retail their goods to our customers; it is therefore

Resolved, That the name of the association be changed to the Pennsylvania Retail Jewelers' Association, with headquarters in Philadelphia, and that no time or money be spared to increase our membership throughout Pennsylvania and adjoining states. That one of the principal aims of the association shall be the using of the best available means to unite the jewelers' and retail jewelers' associations throughout the country, so that the much needed reforms we greatly want can be accomplished, and the many abuses we labor from be done away with. It was further

Resolved, That it be the sense of this association that its members should not purchase any goods from any manufacturer or jobber who retails; also, that a copy of these resolutions be forwarded to the journals of the trade for publication.

The first meeting of the reorganized body will be held on January 8, at the new rooms, 1128 Arch street.

—We have received from Jacot & Son, of 298 Broadway, New York, their new additions to their catalogue of musical boxes with price list enclosed, which should be in the hands of every enterprising jeweler, as this is a line of goods which is entirely in the power of any jeweler to handle. The catalogues for comprehensiveness of details as to prices, tunes, sizes, etc., leave nothing in doubt or unexplained to the merest tyro in musical matters. The improvement that has been made in musical boxes in the last few years is something wonderful, and the style in which the boxes are made will satisfy the most exquisite taste, and the tunes selected are, of course, the most popular, always bearing in mind the fact, that they are what an educated musical taste demands, but special tunes can be made to order in a very short time, and to those who desire a large repertory of tunes the Messrs. Jacot have introduced a class of boxes with INTERCHANGEABLE CYLINDERS of six tunes each, by means of which the number of airs to a box may be increased indefinitely, and these are kept in stock and may be OBTAINED OR EXCHANGED at any time. The list of tunes contains all the favorite dances, marches, National airs, ballads, and best selections from the most popular operas. We can also assure our readers that Messrs. Jacot & Sons are *headquarters* in the line of musical boxes, and purchasers have the assurance and guarantee that they are dealing with a reliable firm, who desire to give complete satisfaction to their patrons.

—An observer on Cortlandt street, New York, will not fail to notice that the numerous pedestrians on that thoroughfare, without scarcely an exception, are attracted by the beautiful windows of Rogers & Bro., at No. 16, if only to cast an admiring glance *en passant*. During the few weeks preceding the holidays, the dressings of these windows were so exquisite as to justify the statement of several jewelers, that they were the handsomest in the jewelry trade of the city. Though not so distinctively individual as those described in the December CIRCULAR, many suggestions can be obtained from study of the arrangement and classes of goods employed, the framing, coverings and ornamentations, in these window displays. There are two windows about eight feet in breadth and three feet in depth, from an architectural point of view, the windows are too far from the center of the sidewalk, a defect that is counterbalanced by the lowness of their floorings. The framing at the back consists of spacious sliding windows, that lift from the bottom. At the sides of each window are long mirrors. The brilliancy of the wood work and articles, and the beautiful display of bright and harmonizing colors, are the first points of the dressing to arrest attention. When the writer viewed these windows the bases were covered one-half by a fine peacock blue plush cloth, the other half by an olive green cloth of similar excellent quality. Roughly but artistically arranged, these coverings formed a most charming ground. At each inner corner was a plateau upon which was set an artistically designed candelabrum, with floral ornaments in natural colors. In the centre back of each window was a large folding silver plated mirror, on each side of which were flower stands with natural flowers. Symmetrically arranged were silver plated pieces of original designs. The transparency of the back windows afforded a view of the beautiful interior of the store, thereby enhancing the effect. The windows are illuminated each by two large incandescent globes, and on dark days and in evenings, the effect of the illumination upon the mirrors, bright goods and frame work, combined with the brilliancy of the colors, is dazzling and enchanting.

—Ira Barrows, of the New York office of the firm of H. F. Barrows & Co., made his usual holiday visit to North Attleboro, at the close of the year's business.

The Denison, (Tex.) *Workman* of recent date contained a lengthy and complimentary account of the business and some points of the life of W. A. Peck of that town.

—George F. Kunz, the world renowned mineralogist, with Tiffany & Co., has another feather in his cap. He has just been elected a member of the Imperial Mineralogical Society of Russia.

—M. Zineman & Bro., S. Tenth st., Philadelphia, have chronicled a busy season and their sales show an increase of \$10,000 over those of the previous year. They are actively engaged in preparations for another season, when they will show many specialties that will interest the trade.

—We are in receipt of a catalogue of optical goods, issued by T. H. McAllister, manufacturing optician, 49 Nassau street, New York. The pamphlet contains full descriptions and prices of spectacles, eye glasses, opera glasses, field glasses, spy glasses and telescopes, microscopes, magic lanterns, stereopticons, etc.

—Frederick Dreher, formerly of 1668 Second avenue, New York, is now located at 16 Maiden Lane, where he carries lines of watches, diamonds, jewelry, optical goods, etc. Mr. Dreher is a good watchmaker, and makes a specialty of repairing for the trade. In the price list issued by him it will be seen that his charges are low, and that his work is complete in its range.

In a special issue of the Montreal *Herald*, recently published and entitled the Dominion Edition, full descriptions of the following well-known jewelry establishments are given: P. W. Ellis & Co., Toronto; W. F. Doll, Winnipeg; Davidson Bros., Van Couver; Hodgson, Sumner & Co. and John H. Jones & Co., Montreal, and James Trotter, Galt.

—An extremely pretty announcement card and souvenir was issued last month by Phillips & Armitage, the new firm of jewelers of Jamestown, N. Y. An artistic little folder having on its front cover a fine lithograph of an Alpine scene, enclosed a neat bookmark made of material to imitate celluloid. The idea of the bookmark was suggested by the communication published in a recent issue of THE CIRCULAR in its Our Round Table department.

—There is probably no horological school in the country better equipped with tools and appliances than that of D. D. Palmer, of Waltham, Mass. Among the most complicated of these is a damasceneing machine made by John Stark, of the same place. Students who place themselves under Mr. Palmer's instruction enjoy exceptional advantages in this respect and also have the privilege of working earlier or later than the regular hours, if they desire.

—George C. Booth, for the past nine years with Fowler Bros, has engaged with Hutchison & Huestis, ring makers of 185 Eddy street, Providence, to represent them on the road. Mr. Booth is one of the best known and most popular travelers in the jewelry trade. He can point to a successful service of 21 years on the road, and so popular and able a man is to be congratulated on his connection with so popular a house as that of Hutchison & Huestis. They are well met.

—The following story comes from Wyoming: A topaz of considerable value was recently found in Popowagie Canon, in Fremont county. About a year ago L. P. Webster secured several similar stones and, being impressed by their beauty and hardness, sent them to Amsterdam, Holland, to be cut and polished. The result of the operation was recently returned to him in the form of five brilliants varying in size from one-quarter carat to one carat. Mr. Drummond has written Mr. Webster that the gems so closely resemble diamonds that only experts can detect the difference, and that aside from diamonds they are the hardest stones ever cut in his establishment. The gems possess a beautiful bluish tint.

—On December 24th, Frank H. La Pierre, 18 East 14th street, received letters patent covering the manufacture and sale of the "Shakespeare Bracelet," which has achieved such a wonderful popularity this season. This invention of Mr. La Pierre is one of the most taking novelties that have appeared in the market for some time. The demand for them has been so large that it was found impossible to supply it though the factory was kept running nights all through the holiday season. Imitations have appeared, as is always the case where a meritorious article proves successful. Dealers should be cautioned against buying any but the genuine "Shakespeare bracelet" manufactured and sold by the patentee himself. The inventor is determined to protect his rights, and they will render themselves liable for infringement and damages.

—Jeweler Morris D. Fletcher, of Springfield, has gone to Hartford, Conn., and is with Hansell, Sloan & Co.

—Hermann Emerson, on Union street, I. A. Willey, on Exchange street, and Charles B. Woodfall, on Exchange street, are numbered among the jewelers who were overwhelmed by the great Lynn fire.

—Since December 1st, A. N. Clark, the well-known manufacturer of watch keys, Plainville, Conn., has been making all his keys with the size of the square stamped on each. This is an improvement that will be appreciated.

—Up in a little room at 363 Washington st., Boston, there is the only tortoise shell dealer in the city of any large account. W. C. Whittaker is the proprietor's name, and he says that this is his second year in Boston, and that the trade is not what he expected it would be. He manufactures the very best line of goods, and says that the people that spend money for such things don't seem to be spending as much as usual.

—O. W. Bullock & Co., Springfield, Mass., have established a record for the ingenuity of their invention and the excellence of all their manufactures. They do not enter into competition with cheap foreign tools, which are generally poor imitations of American tools, but maintain the quality at all hazards. In this, as in other cases, the best is the cheapest. The motto of this house is one which should appeal to every reader of THE CIRCULAR: "American Tools for American Workmen."

—Among the many beautiful calendars for 1890 received at THE CIRCULAR office before going to press that of the Crescent Watch Case Co. deserves special mention. It is a large lithograph of a female head reproduced from a water color painting made especially for the purpose at the order of the company. They can be had upon application to the office of the company. We are also under obligations to H. Z. & H. Oppenheimer, 48 Maiden Lane, for a similar calendar bearing a female face of ideal beauty.

—It will be interesting to the trade everywhere to know that the immense establishment of Spaulding & Co., Chicago, employing a capital of nearly half a million dollars, has met with a greater success than even the most enthusiastic members of the corporation itself believed possible. The sales during December have been simply astonishing, and although the store handles nothing but the finest goods obtainable, its broad aisles have been crowded daily with purchasers. It is proof positive that the sale of high class jewelry is constantly increasing, and that the future of the industry is everything that those interested could desire.

—Lapp & Flershem, the progressive wholesale jewelers of 92-98 State street, Chicago, Ill., as they announce in a circular issued last month, are carrying a large line of "Victor" watches, which are among the best low priced watches in the market. They are stem wind and set, have jointed back, glass cap, are guaranteed, and are cased in solid silver or white metal. Another circular displays designs of a numerous assortment of goods, the illustrations being full size. "The Busiest House in America" catalogue which the firm recently issued, should be in the hands of every retailer, as a book of reference in ordering goods. It is an enormous affair, numbering over 450 pages, and covers such lines as silverware, marble and onyx clocks, bronzes, Howard watches, diamond set watches, fine gold watches, chronograph watches, opera glasses, gold spectacles, gold eye glasses, umbrellas and canes, gold pens, etc., diamonds, fine gold jewelry, gold chains, gold thimbles, gold locket and garnet jewelry.

—J. T. Williams has assumed the management of the American Horological Institute of 1723 Chestnut street, Philadelphia. A more able man for the position could not be found, as he is both practical and theoretical. Our friends who have read the articles in our columns entitled "Advice to Watchmakers' Apprentices," "Lathes and Lathe Work," and "Problems in the Detached Lever Escapement," should now know they are indebted to this gentleman for the instruction they contained, as until about two years ago, he furnished all these contributions. Since that time a pupil of his has supplied them, owing to Mr. Williams assuming the editorial management of the "*Krystone*." Another strong point this school is making consists in the prizes for excellence they offer to the pupils of not only their own school but to pupils of other schools as well. We know the founders of this institute well enough to assure competitors that the prizes will be justly awarded. The prizes are for model of lever escapement, chronometer detent, lever balance staff, micrometer callipers, and three letter monogram; amounting in all to one hundred dollars. The work offered in competition, will be exhibited at the New York World's Fair, and also in all of the principal cities.

—Colonel W. B. Sharp has engaged with the Middletown Plate Company from January 1, and will represent them on the road.

—Carter, Sloan & Co., 15 Maiden Lane, have our thanks for a handy little calendar pad for 1890.

—The Seth Thomas Clock Co., have just received orders for two tower clocks. One for Danbury, Conn., and the other for Pueblo, Col.

—Hunt & Fuller, 73 Nassau street, make a specialty of mystic shrine jewels and Masonic badges of all kinds. They also do fine repairing and order work.

—Wade, Davis & Co., Plainville, Mass., appear on the market this season, with the largest and most desirable line of lace pins, drops, bracelets, scarf pins, etc., they have ever offered.

—Crossin & Tucker, Providence, R. I., have rung up the curtain for the first act, and judging from the extent and variety of their line this season it will be sometime before the curtain falls.

—Barstow & Williams, 198 Broadway, N. Y. and 29 Point street Providence, R. I., have distributed among the trade a very useful little New Year's gift—a tiny paper cutter of bone bearing their card.

—Koch & Dreyfus, 22 John street, offer the improved No. 60 Trenton Watches, of which they bought out the entire stock of the company, at astonishingly low figures, announced in their advertisement on another page.

—S. F. Merritt, Springfield, Mass., is so rushed with orders for his patent steel eye-glass fastener that the orders now pouring in for his new patent hairpin and eye-glass chain combined, will necessitate an enlargement of his factory.

—A little patented novelty called "The Ely Eye-Glass Cleaner," has just been placed in the market by W. H. Ely & Co., 204 Main street, Middletown, Conn. It consists of two circular wipers of chamois skin attached to a celluloid mounting which can be attached to the eye-glass cord or carried in the pocket.

—Wm. Rogers Mfg Co., Hartford, Conn., expect to start up their branch cutlery shop at Norwich, Conn., immediately after the New Year vacation about January 10th. The weather has caused considerable delay, but when the machinery is finally started the company will have a very complete plant for the manufacture of steel blanks, etc.

—Champanois & Co., 5 Maiden Lane, manufacturers of gold jewelry, state that the sale of their "Best Lever" button have been largely increased during the past year. Their line of white stone goods, of which they offer a great variety of patterns, has also proved very salable, and in consequence they are preparing a finer variety of new patterns than ever before shown.

—C. W. Schumann & Sons, 860 Broadway, have on exhibition another painting by Constantin Makoffsky, entitled "The Judgment of Paris", and comparing favorably in style and execution with the other masterpieces by the same artist that have already attracted so much attention.—"The Russian Wedding Feast" and "Choosing the Bride." The picture is drawing large crowds and is very favorably spoken of by critics.

—The suit of A. Bitner, ex-superintendent of the Keystone Watch Co., Lancaster, Pa., against W. J. Atkinson, W. Z. Sener and Dr. Schellenberger, stockholders of the company, charging them with fraud and conspiracy, came to an inglorious termination in the Lancaster court last month, Mr. Bitner's counsel throwing up the case in disgust, as he was utterly unable to find any evidence to substantiate the charge.

—The S. Cottle Co., 860 Broadway, New York, who are always producing new designs, specialties, etc., to keep the trade interested in their line of goods, have just introduced as pretty a novelty as the trade has seen for some time. It is a purse composed of a hollow, exquisitely chased silver or gold ball or bulb combined with a silk top. The purse is made in various designs and sizes, and the reader by referring to the illustration on another page will see that it must prove a selling novelty. Patent letters have been applied for.

—Goldsmith Bros, 63 East Washington street, Chicago, Ill., have made it a special feature of their business for some time to smelt up the old gold that accumulates in retail jewelry stores. They have adopted a system of procedure that has proved very satisfactory and has largely increased their business with the retail trade. On receipt of shipment of old gold or scraps they send estimate of value, enclosing check or draft to avoid delay. If the offer proves unsatisfactory they return the shipment in exactly the same condition and pay the charges. The advantages of this plan will be apparent at once, and we would advise any making their annual clean up to send the scraps to Goldsmith Bros., and give this plan a trial.

—Admirers of the unique in advertising will find much to interest them in the two advertisements of the American Watch Tool Co. in this issue. The company gives in one advertisement a resume of the several patents that have been granted to them covering the improvements on the Whitcomb and Webster-Whitcomb lathes, and cautions all parties against making, buying or selling any goods infringing these items that are not made by them. In the other is given a very interesting account of the Norumbega tower near Waltham, the relation of which to the Webster-Whitcomb lathe the reader is requested to find out for himself.

—Blancard & Co., manufacturers, of 36 and 38 John street, have issued their new catalogue illustrating their staple line of settings, bases, balls and galleries, and affording a ready means to order from. Blancard & Co., possess facilities second to none for the manufacture of goods of this class. Their factory is fitted up with all the latest improved machinery, and their long experience in this specialty gives them a superiority that is now generally conceded by the trade. They were one of the first to engage in this industry, and the firm has kept pace with all improvements in their line, availing itself of every aid that machinery and inventive skill could furnish. As a result their factory is the completest of its kind, and their facilities for turning out goods without an equal. The catalogue before us is a strong and handsomely bound book of 90 pages containing besides illustrations of all the different styles of settings, galleries etc., made by the firm, descriptions, prices and other useful facts, the individual setting being so numbered and classified that no mistake need be made in ordering. The trade mark of the firm has become too well known to require any description, and is a guarantee of the highest excellence. The patent setting of the firm which was formerly made laboriously by hand is now turned out by machinery just as perfectly in form and finish. Many of the designs given in the catalogue are unique, and all are claimed to be the best and most reliable of their kind.

Among the Watch and Clock Companies.

—The trade pronounce the United States Watch Co.'s ladies' watch among the finest on the market.

—The Prescott Watch Trader's Association, England, is making a vigorous protest against the importation of American watches into that country.

—Paillard Non-Magnetic Watches are in large demand, and A. C. Smith, the general selling agent, promises some desirable additions to the line for the coming season.

—Arrangements are now in progress at the Dueber-Hampden Works, to increase in 1890 the output to at least 900 watch movements and 2,000 watch cases per day.

—The Trenton Watch Co. are now prepared to fill orders for their new nickled movements either separate or cased. These movements promises to become exceedingly popular with the trade.

—Of the first lot of 1,000 6-size movements of the United States Watch Co., Waltham, Mass., nearly 5,000 have been delivered, and the balance of the lot have been spoken for. Another lot of 15,000 will be at once commenced.

—Superintendent Cain, since taking charge of the Lancaster factory, has revolutionized the method of doing the work, and it is said the result is that a great deal more and better work is effected, with the same number of hands.

—Royal E. Robbins of the American Watch Co., was a member of the committee from Boston, Mass., which called upon President Harrison at the White House, on Dec. 21, to urge the appointment of Abbott Lawrence as collector of the Port of Boston.

—It looks as though the Waltham Company would be forced to build another wing at no distant day, as every inch of room is, or is about to be utilized. It was thought that by moving the entire dial making business to the dial house at the south end of the factory, that all the room that was needed at present would be gained, but the orders have so increased that the company finds itself doing the greatest business in its history. Especially is this true of the non-magnetic watches.—*Waltham Tribune.*

—The Chicago newspapers occasionally break out afresh with what they suppose they know about the selling, or the chances of selling, the Elgin National watch works to the English syndicate. Elginites are determined to consider such a thing preposterous as long as possible. The management of the Elgin company make a general and decided denial to all statements bearing on a proposed sale of the plant. The business is in a most prosperous way, and, it is rumored that an increase of force of 1,200 persons will shortly be made.

—F. W. Hoffman, of Marsh & Hoffman, Albany, N. Y., has secured a patent on a striking attachment for watches and clocks. It is said that Mr. Hoffman has succeeded in interesting several capitalists in his invention, and will soon establish a factory at Albany.

—The sale of the Aurora watch factory to Charles D. Rood, is regarded by many as effected, though the \$20,000 gift for Mr. Rood is not complete by over \$5,000. Mr. Rood is now in Massachusetts. He expressed himself as fully satisfied to complete the purchase at \$100,000.

—The E. Howard Watch and Clock Co. have been given the contract for supplying the immense building of McMahon & Wren at Bridgeport, Conn., with one of their best tower clocks. It will have four dials each ten feet in diameter, and will be illuminated by electric lights.

—An extension of the south rear wing of the Hampden watch factory at Canton, Ohio, will be commenced in the early spring. It will be 250 feet in length, three stories in height, and will be utilized as additional room for some of the already over-crowded departments of the works.

—The tool room of the Otay watch factory is being fitted up. Watch machinists have just completed several reamers, taps, arbors, counter drills, lathe drills and other tools, and when the further supply of watchmakers from the East arrive, they will be readily supplied with tools for immediate work.

—The Hampden product in November averaged over eleven dollars per movement. This high average the company ascribe to the fact that legitimate watch dealers generally are showing a preference for full jewelled, adjusted watches. This is also proved by the increasing demand for their higher grades of cases.

—Albert H. Potter, inventor and manufacturer of the world-renowned "Potter Watch," returns to Geneva, Switzerland in S. S. *La Gascogne* to-day (Dec. 28th), after a few weeks visit among the watch factories of America. Mr. Potter, we understand, sold while on his visit one of his valuable inventions to the Trenton Watch Co.

—Albert H. Potter, the well-known inventor of chronometers and watches, Geneva, Switzerland, who has been on his annual visit to the land of his birth, sailed for home on the *La Bourgogne*, last Saturday. Mr. Potter, while here, renewed his old acquaintance with friends and visited the various watch factories. During his two months' stay he was banqueted by the Waltham and the Elgin Companies.

—In an article on the growth of building during the past year, the Elgin (Ill.) *Courier* of a few days ago remarks: "However the prospective enlargement, most important to the city is that of the watch factory, which is being increased to a capacity of 2,500 watches a day. Its present output is something over 1,700, and its force of employees 2,800. To effect the increase will require at least 1,200 more, making a total of 4,000. The company is expected to do much building during the spring and summer, just how much is not yet announced."

—A remarkably pretty card is being issued by the Illinois Watch Company. It represents a letter mailed from Japan to the company, and is a very close imitation of the original, a portion of the envelope is torn away and the contents exposed to view. The Japanese postage stamp are accurately reproduced, and bear the usual cancellation marks. On the reverse side is a neat representation of a wax seal over the folds of the envelope; around this are the name and address of the retailer to whom it will be furnished in quantities for distribution among their customers.

—In the prize essay competition on the subject "What the Waterbury Watch Has done for the World," many hundreds of MSS were received from all corners of the United States. The judges proceeded carefully and individually, in the task of selection, and finally arriving at a unanimous verdict in favor of the *nom de plume* "A. S. Cutter," for the first prize, fifty dollars. The "A. S. Cutter" envelope being opened disclosed the writer's real identity to be Erastus A. Dean, Brandon, Vt., P. O. Box 167, certified by D. F. Sexton. The writer bearing the *nom de plume* of "Mox" received the second prize, \$25. Upon opening the envelope the judges read the name of "Julius S. Mallory, P. O. Box 466, Beardstown, Ill.," certified to by Pappmeir & Sons. The third prize fell to "Epictetus," or A. Z. Williams, Box 98, Chicago, Ohio. Carl Gulberg, of 90 Newark avenue, Jersey City, N. J., won the fourth. At that point the judges ceased from their labors, but it was resolved by the Waterbury Watch Co. that the non-recipient essays should be read over again, and a number of the more meritorious ones selected. To each of these the company will send an order for a watch upon the dealer who forwarded the essay.

—Edward P. Baird & Co., clock manufacturers, at No. 112 Queen street, Montreal, have decided to locate at Plattsburg, N. Y., for the manufacture of clocks for the American trade. They have leased the first and second floors of the Hartwell building for a factory. The building is already supplied with all the necessary machinery, enabling the commencement of operations at once. The firm are general clock manufacturers, but at present are giving especial attention to their specialties, advertising, composite and self-winding clocks. The more urgent orders at present are on the first named. The clocks are provided with a Seth Thomas movement, and are of a quality to insure a large sale.

—On November 29, R. E. Robbins and T. M. Avery, filed a suit in the United States Court against the Columbus Watch Company, alleging that the latter company are using and selling nine useful patents granted to Duane H. Church and Caleb H. Colby, these patents having subsequently been transferred to the American Waltham and Elgin Companies. The petition claims that complainants have been damaged \$50,000, and asks for a restraining order to prevent the Columbus Company from making, selling or using any watches containing or embodying any of the inventions. In reference to this suit the Columbus Company say: "In regard to the pendant setting suit of the trustees of Elgin and Waltham Companies against us, in the claim set up by the trustees, they make it appear that they have a right to the invention of setting and winding by a longitudinal motion of the winding arbor, which was done by others before the Waltham and Elgin Companies ever made it. We are prepared to prove that we are working under our own patents, and that no damage can possibly come to customers, and will defend our patents and the rights of our customers."

—The well-known Philadelphia house of Simons Bro. & Co., 618 Chestnut street, have fitted up their diamond department in most attractive style, and with every convenience to afford a better exhibition of gems to customers. The approach to the room is guarded by locked doors. The wainscoting is of ebony and the furniture and carpets are of artistic and agreeable design.

—Owing to the unprecedented increase of the business of the Essex Watch Case Company, which, as the management say, is attributable chiefly to advertising, they have been obliged to seek more commodious quarters and increase their facilities for turning out work. With this in view they have rented the large new building of Kremetz & Co., in Newark, into which they will move before April 1. Addison Conkling, general selling agent for that company, is enjoying a heavy demand for their gold filled cases.

—One of the most brilliant exhibits in silverware at the fair held last month at the American Institute was that of the Holmes & Edwards Silver Company, Bridgeport, Conn., and few visitors failed to observe and admire the rich effect produced by the varied assortment. Among the most noticeable features of the collection were spoons and forks, made under the Warner patents, manufactured of the best nickel silver metal, inlaid with sterling silver and then plated entire. The rich finish is of such a durable character that the company sells these goods under a guaranty that they wear for twenty-five years.

—A very useful book to all metal workers has recently been published by Henry Carey Baird & Co., 810 Walnut street, Philadelphia, Pa., under the title, "The Metallic Alloys." It is a practical guide for the manufacture of all kinds of alloys, amalgams and solders used by metal workers, together with their chemical and physical properties and their application in the arts and the industries. An appendix is devoted to the coloring of alloys. The book is translated and edited, chiefly from the German of A. Krupp and Andreas Wildberger, with extensive additions by Wm. T. Brant, one of the editors of "The Techno-Chemical Receipt Book," etc. It is illustrated with 16 engravings, and is complete, it having 428 pages. Its price is \$2.50.

New York Jewelers' Board of Trade.

At special meeting of the Board at their rooms, Friday, Nov. 29th, the following firms were admitted to membership: Howard & Son, (The Sterling Co.), 175 Broadway, N. Y. City; C. G. Alford & Co., 200 Broadway, N. Y. City; A. Paul & Co., 373 Washington street, Boston, Mass.; D. C. Percival & Co., 393 Washington street, Boston, Mass.; Geo. H. Richards, Jr. & Co., 383 Washington street, Boston, Mass.; Henry T. Spear & Son, 370 Washington st., Boston, Mass.; Morrill Bros. & Co., 403 Washington st., Boston, Mass.; Chas. Jacques, 2 Maiden Lane, N. Y. City; Gunzberger Bros., 25 Maiden Lane, N. Y. City; C. K. Colby, 11 John street, N. Y. City. Smith & Paterson, Boston, Mass., were admitted during December.

SPECIAL NOTICES.

Notices under this Heading, not to exceed Six Lines, (50 words) \$1.00 each insertion. One Cent for each extra word.

Advertisements, to insure insertion in this column, must be received by the 24th of each month. Advertisers having letters addressed in care of this office, must inclose postage for answers forwarded.

WOODCOCK'S SCHOOL FOR WATCH-MAKERS, Winona, Minn., offers unrivalled facilities for acquiring a thorough practical knowledge of every branch of the business. Terms very reasonable.

TO THE TRADE.—I make a specialty of supplying the trade with stones for jobbing purposes. Parties having jewelry out of which the stones have been lost; sending their orders by mail or express, will have them promptly attended to. A large stock of white and colored imitation stones on hand. **W. ARCHIBALD**,
73 Nassau street, New York.

NOW, that you are busy send us your overwork, and by so doing save yourself from overwork and worry.

CHICAGO HOROLOGICAL INSTITUTE.

W. H. SAXTON,
Dealer in Diamonds, Fine Watches and Jewelry,
75 State Street,

NEW LONDON, Conn., Sept. 18, 1889.

Mr. W. F. A. Woodcock, Winona, Minn.

Dear Sir:—

It is with a feeling of pride that I point to my certificate of graduation from your school, because I consider that my possession of it implies that I have graduated from the *Best Horological School in the Country* and that I am, owing to the instruction I received at your school and to the unsparing pains you took to make me such, a first class watchmaker. I shall ever be pleased to recommend any one who desires to learn the watchmaking trade thoroughly to attend your school. The special tools which you teach your pupils to make are a valuable acquisition to a watchmaker's set, and I should consider my cabinet incomplete without them. The facilities which you possess in the way of bench room, light, etc., are unsurpassed and the class of work so varied as to embrace everything that comes under the watchmaking line. The results of the time which I spent under your instruction are highly satisfactory, and I shall ever appreciate your kindness and painstaking, and bestow unsparing praise on your school.

Yours truly,

W. H. SAXTON, Jr.

WATCHES DEMAGNETIZED without taking the movements from the case. Complete satisfaction guaranteed or no charge.

CHICAGO HOROLOGICAL INSTITUTE.

TRAVELING SALESMEN, acquainted with the jewelry trade, can make money by carrying a side line of our celebrated "Diamanta Spectacles and Eye Glasses;" samples easily carried; nicely packed. **M. ZINEMAN & BRO.**,
Philadelphia.

TRAVELLER with a good trade through the Far West wants a fine line of goods to sell to the best trade. Will be ready to make change about Jan. 1st,

Address, Q,

Care THE JEWELERS' CIRCULAR.

FOR SALE—Having determined to take an interest with my brother in another line, I am now closing out my entire stock, and will sell the Lease extending three years; the Goodwill; the Fixtures of all kinds; Regulators, Safes, Chronometers, Tools and Materials and Plant generally, the same being the finest in St. Paul, and known to the Eastern trade to be the best establishment in the city, enjoying for long years a solid and growing trade. Apply for schedule and prices to the proprietor,
P. F. EGAN,

Jeweler, 115 East Third Street,
ST. PAUL, MINN.

References, { **GORHAM M'F'G Co.**
{ **CARTER, SLOAN & Co.**

IT WORKS LIKE A CHARM AND SO SIMPLE YOU'LL LAUGH.—A thorough practical, and simple method of demagnetizing watches (without taking down), with all necessary appliances sent by express for \$2. Address, with amount enclosed,

FER'D F. IDE,

Supt. Peoria Watch Company,
Peoria, Ill.

WANTED.—Situation, by a first-class watchmaker, thoroughly competent to take charge of a good run of work; have good set of tools and can furnish reference from last place. Address,
HOROS,

Care THE JEWELERS' CIRCULAR.

CHICAGO HOROLOGICAL INSTITUTE keep a full corps of fine workmen to do trade work. Send for their price list and send them your work.

WANTED.—A few traveling men who are practical watchmakers, and have the time—to call the attention of the craft to the Mosely Lathe and Attachments, through the East and Southwest. Address,
MOSELY & CO.
Elgin, Ill.

SEND YOUR KEY WIND WATCHES, that you want changed to stem winders to the
CHICAGO HOROLOGICAL INSTITUTE.

WATCHMAKER AND JEWELER wants position; first-class workman; has had 17 years' experience at the bench; good set of tools and lathe. Can furnish best of references. Advertiser wants a good position; none other.
Address, **BOSS**,

Care THE JEWELERS' CIRCULAR.

NOTICE.—Salesman having an established city and vicinity trade in jewelry, etc., desires a position with a prominent manufacturer or jobber in watches, jewelry, etc.
Address **EXPERIENCE**,
Care THE JEWELERS' CIRCULAR.

FOR SALE.—Whitcomb No. 1½, ½ Hard Lathe, complete, with six split chucks, 2 step chucks, 1 taper chuck and tapers and brasses, including revolving chuck stand and glass; all for \$30.00 cash. \$10.00 will buy new improved Hall's staking tool. Send \$2.00 and I will send either by express **C. O. D.**

CHAS. SCHURBERG,

Sweet Springs, Mo.

WANTED.—An artistic designer of jewelry.
Address, "Art,"

Care THE JEWELERS' CIRCULAR.

WANTED.—A young man who is a good work man on watches and jewelry. Must be steady and sober.

W. D. J.,

Care THE JEWELERS' CIRCULAR.

A TRAVELER well acquainted with the retail trade of the South and West would like to represent some house in those sections. Best references.

Address, **W. N.**,

Care THE JEWELERS' CIRCULAR.

WANTED.—A position as foreman in a jewelry factory; fourteen years' experience with John A. Riley, 860 Broadway.

Address **C. F. HAAS**,

290 West Fourth St., New York.

The C. G. Harstrom Pat. Adjustable Lifting Spring



A fine steel spring, nicely finished, not tempered, and easily fitted.

Write your Material House for a sample doz. to look at, or send to cts. for sample to

N. Y. WATCH CASE SPRING MFG CO.,
71 Nassau Street, New York.

BEGIN THE NEW YEAR RIGHT

BY USING THE

"Complete Business Register,"

The best arranged book for keeping a record of Daily, Weekly and Monthly Sales, Expenditures, etc. Send for free sample sheet, prices, etc.

H. W. PAMPHILON, 30 Bond St., New York.

BUYERS' DIRECTORY.

Aluminum.

Platt, Chas. F.—Aluminum, Platinum and Platers' and Electro Platers' Silver. Assayer, Sweep Smelter and Refiner. 4 Liberty Place, N. Y.

Anti-Magnetic Shields, Insulators, etc.

Anti-Magnetic Shield and Watch Case Co.—Manufacturers and Jobbers in Watches, all classes of Jewelry, Materials, Clocks, Silver Ware, &c., and Manufacturers of Giles' "Anti-Magnetic Shield." Illustrated catalogues furnished to dealers on application. 101 & 103 State St., Chicago. New York Office, 1 Maiden Lane.

Atkinson Bros.—Manufacturer's of the "Ajax" Watch Insulator, 931 Chestnut St., Phila.

Art Pottery and Glassware.

Bawo & Dotter—30 Barclay Street, New York. Importers of Royal Worcester, Doulton, Crown Derby, Carlsbad Pottery, etc., and dealers in general lines of Bric-a-Brac and Art Pottery Goods.

Dorflinger, C. & Sons.—36 Murray St., New York. Manufacturers of Dorflinger's American Fine Cut Glass. Everything that is used in glass for the table.

Klingenberg, A.—Importer of European Novelties in Art Pottery and Glassware, Royal Worcester, Crown Derby, Doulton, etc. 35 and 37 Park Place, New York.

Straus, L. & Sons.—Importers and Manufacturers of Pottery, Bric-a-brac and Art Glass, Clocks and Bronzes, adapted to the jewelry trade. 42-48 Warren St., New York.

Assayers and Sweep Smelters.

- Baker & Co.**—Gold, Silver and Platinum Refiners, Assayers and Sweep Smelters. 408 New Jersey Railroad Avenue, cor. Murray St., Newark, N. J.
- Howard, S. P.**—Gold and Silver Refiner, Assayer and Sweep Smelter. Gold and Silver of any fineness supplied to manufacturers. 8 and 10 John Street, New York.
- Lelong, L. & Bro.**—Gold and Silver Refiners, Assayers and Sweep Smelters. Cor. Halsey and Marshall Sts., Newark, N. J.
- Schawel, James & Co.**—Assayers, Gold and Silver Refiners and Smelters. Waste of all kinds containing gold and silver refined. Assays made on Gold, Silver and Ores at short notice. No. 29 John St. New York.
- Wundoehl, H.**—Gold and Silver Refiner, Assayer and Sweep Smelter. 21 John Street, Bet. Broadway and Nassau Street, New York. The highest price paid for Old Gold and Silver. Fine Gold, Silver and Copper always on hand.

Band Rings.

- Knapp, Charles**—41 Maiden Lane, N. Y. Specialty: Superior Band Rings, also Ring Shanks and Heads for Seal and Diamond Rings; Die Sinker and Stamper for Jewelry purposes.

Badges and Medals.

- Braxmar, C. G.**—36 Cortlandt street, N. Y. The largest manufacturer of Badges and Medals in America. Send for Illustrated Catalogue, 100 pages, 1000 designs.
- Frick, John**—Maker of Medals, Badges and Special Jewelry, for prizes, etc. Agent for Carpenter's Antique Oxidizing Solution, \$1.25 per ounce bottle. 6 Liberty Place, (opp. 21 Maiden Lane) New York City.
- Schwencke, W.**—Manufacturing Jeweler. Every Description of School Badges and Medals, Athletic, Rowing, Shooting, Bicycle Badges and Medals. No. 8 John St., New York.
- Stockwell, E. R.**—Manufacturer of Badges and Medals in Gold and Silver; also Club and Class Pins. No. 19 John St., N. Y.
- Stoll, Robert.**—Manufacturer of Medals and Badges for all the leading Bicycle and Athletic Clubs. 19 John Street, New York. All work warranted as represented. (No catalogue.)
- Wilkinson, C. B.**—Manufacturing Jeweler, 42 John St., N. Y. Medals, Badges and Masonic Jewelry, a specialty. Designs furnished free upon application.

Black Onyx Jewelry.

- Cox & Sedgwick Manuf. Co.**—Manufacturers of Black Onyx Jewelry, 26 John St., New York.
- Eagle Jet and Onyx Manufacturing Co.**—Office and Salesroom, No. 41 Maiden Lane, New York. Factory, 48 and 50 Maiden Lane.
- Fowler Bros.**—108 Broadway, N. Y.; Providence, R. I. Manufacturers of Fowler's English Cape Stone Jewelry.
- Lawson & VanWinkle.**—11 Maiden Lane, N. Y. Manufacturer of Black Onyx Jewelry. Coral repaired for the trade. Goods sent on approval to responsible dealers.
- Wcglom, Gilbert T.**—Manufact' r of (exclusively) Black Onyx Jewelry, 32 & 34 John St., N. Y.

Blue Enameled Lockets.

- Bissinger, Philip & Co.**—Importers of Diamonds, Pearls and Precious Stones. Agent for the Bohemian Garnet Goods. Blue Enameled Lockets and Coral Goods. 22 John St., N. Y.

Bohemian Garnet Jewelry.

- Bissinger, Philip & Co.**—Importers of Diamonds Pearls and Precious Stones. Sole Agent for the Bohemian Garnet Jewelry. Blue Enameled Lockets and Coral Goods. 22 John St., N. Y.

Bonnet Pins.

- Lawson & VanWinkle**—Bonnet Pins in Moonstone, Pearl, Turquoise, Diamonds, Sapphires, Rubies, Opals, Onyx, Hematite and Imitation Pearls; also a fine line of Black Onyx Jewelry, 11 Maiden Lane, New York.

Clock Companies.

- Ansonia Clock Co.**—Manufacturers of Clocks, 11 Cliff St., N. Y.; 133 Wabash Ave., Chicago, Ill.; and 23 Fore St., London, England.
- New Haven Clock Co.**—29 Murray Street, N. Y.
- Seth Thomas Clock Co.**—20 Murray Street, N. Y.
- The Globe Clock Co.**—Manufacturers of Walnut, Iron and Nickel Clocks. S. F. Myers & Co., Agents, No. 50 Maiden Lane, New York.

Waterbury Clock Co.—Manufacturers, No. 10 Cortlandt St., N. Y. and No. 114 Wabash Ave., Chicago, Ills.

Welch, E. N., Manufacturing Co.—Manufacturers of American Clocks. No. 6 Warren St., N. Y.; 141 State St., Chicago.

Wm. L. Gilbert Clock Co.—No. 6 Murray Street, N. Y.; 54 Madison St., Chicago. Manufacturers of Clocks. Factories, Winsted, Conn.

Cameo Cutters, Etc.

Bonet, L.—Established 1866. Cameo Portraits. Importer of Precious Stones. 927 Broadway, New York.

Charms & Gold Watch Keys.

Held, A. & Co.—Manufacturing Jewelers, Charms and Gold Watch Keys, with French and English Rachets, a specialty. 15 John St., N. Y.

Clock and Watch Signs.

Washburne, E. G. & Co.—46 Cortlandt Street, are the oldest firm engaged in the manufacture of Signs in the U. S. Clock Dials, Watch Signs, Spectacle and Eyeglass Signs, also Signs to fit any business in stock.

Coral and Coral Jewelry.

Lawson & Van Winkle—Coral Ornaments Made, Repaired and Re-finished Equal to New. No. 11 Maiden Lane, New York.

Crucibles.

Berge, J. & H.—Established 1850. Importers of Sand Crucibles, Covers, Chemical Porcelain. Glassware, and Jewelers' and Assayers' Supplies, 95 John Street, N. Y.

Diamond Brokers.

- Anderson, Otis**—Diamond Merchant and Broker; always ready to pay cash for bargains in Diamonds and Precious Stones, 10 Maiden Lane, N. Y.
- Friend S. & Son**—Brokers and dealers in Diamonds 33 John Street, cor. Nassau St. New York.

Diamond and Precious Stone Importers

Bissinger, Philip & Co.—Importers of Diamonds Pearls and Precious Stones. Agent for the Bohemian Garnet Goods. Blue Enameled Lockets and Coral Goods. No. 22 John St., N. Y.

Breidenbach, R. A.—Importer of Diamonds, Pearls, Rubies, Sapphires, Opals, Moorstones, Turquoises, Amethysts, Garnets, Topazes, Hematites, Cameos, Sardonyx, Tigereyes, Catseyes, Doublets, Foil Backs, Fine Brilliants, Black Onyx, Agate Goods, Cabinet Specimens, etc. 26 John Street, New York, 94 Friendship St., Providence, R. I.

Bruhl Bros. & Co.—Established in 1848. 14 Maiden Lane, N. Y.; 121 Broad Street, Providence, R. I.; 120 Sutter St., San Francisco, Cal.; 57 Rue de Chateaudun, Paris.

Citroen, Veuve L. B. & Co.—Diamonds. 21 John St., N. Y. Cutting Works, 57 & 61 Rapenburgerstraat, Amsterdam. House in Paris, 62 Rue Lafayette.

Dreyfus, Henry & Co.—Importers of Diamonds, Pearls and other Precious Stones, 25 Maiden Lane, N. Y.

Fera, Henry—Importer of Rough and Polished Diamonds. Diamond Cutting Works, 10 Maiden Lane, New York.

Fox, M. & Co.—Importers of Diamonds, Rubies, Sapphires and Fancy Gems. No. 1 Maiden Lane, New York.

Graham & Co.—Practical Lapidaries, Cutters and Polishers of American Gems and all kinds of Precious Stones. Gems re-polished and re-mounted. 63 Nassau St., New York.

Gruet, Jules.—Importer of all Grades of Real and Imitation Stones. 14 John St., N. Y. and 151 Broad St., Providence, R. I.

Hedges, Wm. S. & Co.—Importers of Diamonds. No. 170 Broadway, corner Maiden Lane, N. Y.

Kahn, L. & M. & Co.—10 Maiden Lane, N. Y.

Lorsch, Albert & Co.—Importers of Precious Stones. 37 Maiden Lane, N. Y. See Back Cover.

Magnus, Charles—Late of the firm of Philip Bis-singer & Co., Importer of Diamonds, Pearls and Precious Stones. 18 John St., N. Y.

Miller Bros.—37 Union Square, New York. Importers of Diamonds and Manufacturers of Fine Diamond Jewelry in 14 k. gold; Initial Sleeve Buttons, Studs, Collar Buttons, Lace Pins, Seals, Medallions, etc. Monograms to orde.

Oppenheimer Bros. & Veith—Importers of Diamonds and Manufacturers of Diamond Jewelry. 35 Maiden Lane, N. Y.

Peterson & Royce—Importers of Diamonds and Precious Stones. No. 189 Broadway, New York.

Randel, Baremore & Billings—Importers of Diamonds, cor. Maiden Lane and Nassau St., N. Y.

Russell, Irving L.—Corbin Building, Room 8, 192 Broadway, N. Y. Importer of Diamonds and Precious Stones, and dealer in Fine Mounted Goods.

Smith, Alfred H., & Co.—Importers of Diamonds, No. 182 Broadway, N. Y.

Smith & Knapp.—182 Broadway, N. Y. Importers of Diamonds.

Tannenbaum, L. & Co.—Importers of Diamonds and Precious Stones. Steam Lapidary Works. Oriental Stones Cut and Polished a specialty. 65 Nassau St., N. Y.

Taylor & Brother.—Importers of Diamonds and Diamond Jewelry. 360 Broadway, N. Y.

Weil, Maurice.—Importer of Diamonds, No. 41 Maiden Lane, N. Y. Amsterdam, 10 Tulp Straat. Paris, 18 Passage Saulnier. Selection packages to responsible parties.

Wickham, D. H. & Co.—Importers of Diamonds. No. 31 Holborn Viaduct, London, 24 Maiden Lane, New York.

Wood, Chas. F.—171 Broadway, N. Y., Importer of Gems and Precious Stones, and Encruster and Engraver.

Diamond Jewelry.

Bissinger, Philip & Co.—Importer of Diamonds, Pearls and Precious Stones. Agent for the Bohemian Garnet Goods. Blue Enameled Lockets and Coral Goods. No. 22 John St., N. Y.

Bornemann, Louis.—Importer of Diamonds and Manufacturer of Rich Diamond Jewelry, 19 John Street, New York.

Bynner, T. B.—Wholesale Dealer in Diamonds, Watches and Jewelry. 177 Broadway, N. Y.

Falkenau, Oppenheimer & Co.—Manufacturers. Diamonds and Diamond Jewelry, 40 Maiden Lane, New York.

Gardner, A. S., & Co.—Diamond Importers and Manufacturers of Diamond Mountings. No. 17 Maiden Lane, N. Y.

Goldsmith, Ingomar & Co.—Manufacturers of Diamond Mountings and Diamond Jewelry, 20 Maiden Lane, New York.

Hansen & Tichenor.—Manufacturers for the Trade, of Diamond Mountings and rich Jewelry. No. 108 West 23d Street, New York.

Jeanne, Leon P.—Manufacturer of Diamond Mountings and Rich Jewelry. 1 Maiden Lane, N. Y.

Leimbach, F. E., Successor to Leimbach Bros.—Manufacturer of Diamond Jewelry and Importer of Diamonds. No. 51 Nassau street, New York. London Office, 33 Holborn Viaduct.

Nissen, Ludwig & Co.—Importers of Diamonds and Manufacturers of Diamond Mountings. No. 18 John Street, New York.

Norling & Bloom—Goldsmiths. Diamond and Etruscan Jewelers. 386 Washington St., Boston, Mass. All kinds of Repairing neatly done.

Randel, Baremore & Billings—Manufacturers of Diamond Jewelry. Corner Maiden Lane and Nassau Street, N. Y.

Sauter, L. & Co.—1 Maiden Lane, N. Y. Importers of Diamonds and Manufacturers of Diamond Jewelry.

Sexton Bros. & Washburn—Importers of Diamonds and Manufacturers of Diamond Jewelry. 41 and 43 Maiden Lane, N. Y.

Schaefer & Egenberger.—Manufacturers of Diamond Mountings and Fine Jewelry. 69 Nassau St., cor. John, New York.

Sheafer, W. H. & Co.—Manufacturing Jewelers, Bracelets, Lace Pins, Earrings, Sleeve Buttons, Studs, Lockets, and Diamond Goods. 108 South Eighth Street, Philadelphia.

Voelker, C. T.—Manufacturer of 18-k. Diamond Mountings, Diamond Jewelry. 15 Maiden Lane, New York.

Waterman & Lehmann—37 Maiden Lane, New York. Manufacturers of Diamond Jewelry and Rings.

Wienhold, J., & Co.—Manufacturer of Fine Jewelry. Diamond Mountings a specialty 24 John Street, N. Y.

Diamond Cutters.

Becker & Kohl.—Diamond Cutters and Polishers. Repairing and Matching a Specialty 35 Ann Street, cor. Nassau, New York.

Mendes, D. De S. & Co.—Diamond Cutters & Polishers, 49 Maiden Lane, N. Y. Re-cutting. Repairing, and Matching a Specialty.

Norden & Co.—Diamond Cutters and Polishers. Repairing, Recutting and Matching. 61 Nassau street, New York.

Randel, Baremore & Billings—Diamond Cutters and Polishers. Corner Maiden Lane and Nassau Street, N. Y.

Enamelers, Etc.

Nutt, J. D.—Enameler on Gold, Silver, and Copper. Linen finished Buttons and Studs. Enameling in colors. 32 and 34 John Street, New York.

Orr, J. C.—Enameler on Fine Jewelry. Enameled in Colors. Linen Finished Buttons and Studs. Band Bracelets. No. 75 Nassau Street, N. Y. Room 13, front building.

Engravers—Stone Seal, Etc.

Park, Wm.—The Stone Seal Engraver. Arms, Crests, Monograms, etc., engraved on precious stones. Metal Seals and Dies Engraved in the Best Style of the Art. 26 John Street, N. Y.

Schliesman, J.—25 Maiden Lane, N. Y. General workman for the trade. Engraver, Chaser and Diamond Setter on Fine Jewelry.

Fancy Goods, Clocks, Bronzes, Etc.

Elaber, S. & Co.—47 West 42d St., New York. Mexican Onyx Tables, Pedestals, Cabinets, etc. Art Workers in Onyx and Bronze.

Nicholas Muller's Sons.—117 Chambers Street, N. Y. Ornamental Bronzes, Clocks, Lamps, Plaques, Thermometers, Inkstands, Mirrors and Cast Metal Novelties of all kinds. Specialty: the Designing and Manufacture of Artistic Metal Goods for the wholesale trade.

Sussfeld, Lorsch & Co.—13 Maiden Lane, N. Y.

Taylor & Bro.—Importers of French Clocks, Bronzes, etc. 860 Broadway, N. Y.

Files, Etc.

Nicholson File Co.—Manufacturers of Files for Jewelers, Watchmakers and Silversmiths. Providence, R. I.

Filigree Jewelry.

Hartmann, P.—Manufacturer and Importer of Gold and Silver Filigree Jewelry. Any special Designs made at short notice. P. O. Box 2454. 36 Maiden Lane, N. Y.

Gold and Silver Cane Heads.

Fradley, J. F. & Co.—23 John Street New York. Manufacturers of Fine Gold and Silver Headed Canes, Umbrellas, Opera Glasses and Novelties in Repousse Silver, such as Match Boxes, Cigarette Cases, etc.

Gold and Silver Plating, Etc.

Bantle, A.—Gold, Silver and Electro-Plating, 130 Fulton and 89 Nassau Streets, cor. Fulton Street, (Room 39), N. Y. Watch Case Polishing.

Jeantheur, Jr., F.—Gold and Silver Electro-Plater and Fire Gilder. Coloring Etruscan and Gold Jewelry a Specialty. 6 Liberty Place, N. Y.

Kronske, Charles—Gold and Silver Plater. 223 Grand St., N. Y. Established 1873. Gilding on Watch Cases and Fine Jewelry a specialty. Out of town work promptly attended to.

Newman, Jr. Louis—Gold Plater, Fine Etruscan Colorer and Gilder. Plating of Watch Cases 14 kt. and 18 kt., and coloring of Fine Jewelry a specialty. 36 John Street, N. Y.

Gold Chains, Etc.

Beck, J. & Son, Manufacturers of Fine Gold Chains and Chain Bracelets, 10 Liberty Place, near Maiden Lane, N. Y.

Carter, Sloan & Co.—Manufacturers of Fine Gold Chain, 15 Maiden Lane, New York.

Kohn, Alois & Co.—Manufacturers of Gold Chains, 11 Maiden Lane, N. Y.

Gold Pens, Pencils, Etc.

Aikin, Lambert & Co.—Manufacturers of Fine Gold Pens, Cases, Holders, Toothpicks, etc., 23 Maiden Lane, N. Y.

Faber, Eberhard.—Manufacturer A. W. Faber's Celebrated Gold Pens and Pencil Cases, Ebony, Pearl, Ivory Holders, Gold Plated Magic, Screw and Slide Pencils, Toothpicks and Novelties. 545 Pearl St., New York.

Hicks, W. S.—Established 1848. Manufacturer of Fine Gold Pens, Pencil Cases, Tooth Picks, and Charm Novelties of every description. Cor. Greenwich and Barclay Sts., N. Y.

Johnson, E. S. & Co.—Manufacturers of Gold Pens, Pen Holders and Pencils. Cor. Maiden Lane and Nassau Street, New York.

Smith, H. M. & Co.—Manufacturers of Fine Gold Pens, Pen and Pencil Cases, Tooth Picks, Pencils, Etc. Jobbers of American Watches. Agents for Paul E. Wirt's Fountain Pen. 83 Nassau St., New York.

Todd, Ed. & Co.—44 East 14th Street, New York. Manufacturers of Gold Pens, Holders, Pencils and Novelties.

Gold Rings.

Bowden, J. B. & Co.—Manufacturing Jeweler.—Solid Gold Rings a specialty. Corbin Building, N. Y.

Bryant, M. B., & Co.—10 Maiden Lane, N. Y. Manufacturing Jewelers; Novelties in Rings, Puzzle Rings, etc.

Folkart, Wm.—Manufacturer of Initial and Seal Rings and Diamond Mountings. A large assortment of Initial and other Rings constantly carried in stock. 4 and 6 John Street, New York.

Henderson & Winter—Manufacturing Jewelers. 15 Maiden Lane, near Broadway, New York. Specialties: Diamond, Ruby, Sapphire, Emerald, Pearl, Garnet, Onyx and Turquoise Rings.

Kirby, Mowry & Co.—117 Harrison St., Providence, R. I. Manufacturers of Diamond and White Stone Rings.

McCall & Newman—Manufacturing Jewelers Makers of the Original Gold Crown Filled Rings. No. 625 Arch St., Philadelphia.

Odeheimer & Zimmern.—Manufacturing Jewelers. 69 Nassau st., N. Y. Complete line of Ladies' and Gents' Initial, Seal, Fancy and Diamond Rings. Gold and Diamond Jewelry.

Ostby & Barton—Manufacturers of Solid Gold Engraved Band Rings, 80 Clifford St., Providence. New York Office, 176 Broadway.

Peckham, Wm. H.—Manufacturers of Solid Gold Seamless Rings and Fancy Embossed Rings, Patent Spectacles, Jewelry, etc. No. 4 Liberty Place, N. Y.

Sauter, L. & Co.—No. 1 Maiden Lane, New York. Manufacturer of Stone Rings of every description, as Diamond, Cameo, Onyx, Turquoise, etc., Scarf Pins, Scarf Rings, Studs and Buttons.

Shafer & Douglas.—Manufacturers of all kinds of Seal, Stone, Turquoise, and fancy rings. No. 3 Maiden Lane, N. Y.

Wood, J. R. & Son—14 John Street, N. Y. Manufacturers of Plain Solid Gold Rings, Engraved, Chased, Children's and Silver Rings.

Hair Jewelry.

Bernhard, A. & Co.—Manufacturers of Diamond and Fine Jewelry, and of Ornamental Hair Jewelry, 2 Maiden Lane, New York.

Moutoux, Wm. E.—Leading Artist in Hair Devices of the most difficult designs, and Manufacturer of Hair Jewelry at reduced prices. Main office 2345 Eighth Ave., near 125th St., N. Y.; Down-town office, 81 Nassau Street, Rooms 1 & 2 New York.

Sauter, L. & Co.—Manufacturers of Fine Gold and Hair Jewelry and Device Work. Pattern Book sent on application. 1 Maiden Lane, N. Y.

Schwencke, O.—Manufacturer of Fine Hair Jewelry. Orders from the country promptly attended to. 8 John St., N. Y.

Horological Schools.

Chicago Horological Institute.—Owing's Building, Adams and Dearborn Streets, Chicago, Ill.

Waltham School of Horology.—Waltham, Mass. D. D. Palmer, Proprietor.

American Horological Institute.—Philadelphia, Pa.

Jewelry Cases, Fancy Boxes, Etc.

American Morocco Case Co.—7 & 9 Bond St., New York, make a specialty of Fine Jewelry and Silverware Cases for the Fine Retail Trade, also Patent Trays in Ebony and Rosewood, for Rings, Watches, etc. Novel Show Window Decorations.

Conradi M'fg Co.—Jewelry, Silverware and Fancy Cases, 35 East 19th St., near Broadway, New York.

Ettlinger, L. & Sons—Makers of Cases and Paper Boxes of every description for Jewelers and Silversmiths. Fine Cases and Trays to order a specialty; also Cards, Tags, Cotton, Tissue Paper, &c. 80 Nassau St., N. Y.

Haensler, Charles C.—Manufacturer of Fine Velvet, Plush and Morocco Cases for Jewelry, Silverware, &c. Trays for Show Cases and Windows. Fine Velvet Cases for Diamond Jewelry, 37 John st., New York. Chicago agency: Richards & Rutishauser, 151 State st., Chicago.

Hebbard & Brother—Manufacturers of Jewelry and Silver Ware Cases, and Fancy Wood Chests for Tea Sets and Flat Ware. 860 Broadway, New York.

Schwarz, N.—Manufacturer of fine Cases for Jewelry and Silverware. 866 Broadway, New York.

Valfer, S. & Co.—Manufacturers of Jewelers' Boxes, Trays, Fancy Ornaments for Show Windows. Dealers in Cards, Tags, Paper and Findings. Trays to order a specialty. 66 Nassau Street, N. Y.

Welch & Miller—169 Broadway, N. Y. Manufacturers of fine Morocco, Velvet Russia, Brocade and Plush Jewelry Cases. Trays of every description; Jeweler's Cotton and Twine.

Wiggers & Froelick—No. 60 Nassau st., N. Y. Manufacturers of Cases for Jewelry, &c., of every description. Trays for Show-cases, Stands for Show-windows, etc.

Jewelers' Findings.

Dennison M'fg Co.—Paper Jewelry Boxes, cards, tags, pink and white cotton, etc. etc. New York, Boston, Chicago, Cincinnati, Philadelphia, St. Louis.

Fuller, Geo. H. & Son—Jewelers' Findings, Gold, Silver, Gold Plated and Fire Gilt. Pin Stems, Joints, Catches, Split Rings, Chain Hooks and Swivels, Ear Wires, Chain Bars, etc. 99 Exchange Street, Pawtucket, R. I.

Jewelers' Scales.

Troemner, Henry—Manufacturer Diamond and Fine Gold Scales. 710 Market St., Philadelphia.

Jewelry Manufacturers.

Ball, Wm. H. & Co.—15 John Street, New York. Manufacturers 14 k. Gold Bracelets, Hair Pins and Diamond Mountings. Bracelets especially.

Bissinger, Philip & Co.—Importers of Diamonds, Pearls and Precious Stones. Sole Agents for the Bohemian Garnet Jewelry, Blue Enameled Lockets and Coral Goods. 22 John St., N. Y.

Carter, Sloan & Co.—Manufacturing Jewelers, 15 Maiden Lane, New York.

Champenois & Co.—5 Maiden Lane, New York, Manufacturers of Solid Gold Jewelry. Specialties: Engraved and Enameled Goods, White Stone Goods, and "The Best Lever" Sleeve and Collar Button. Imitation Pearl Goods.

Cottle S. Co.—Manufacturers of Fine Jewelry. 860 Broadway, N. Y.

Cox & Sedgwick Manuf. Co.—Manufacturers of fine Onyx and Colored Jewelry. 26 John St., New York.

Day & Clark—Manufacturers of Gold Jewelry generally. Specialty of Bracelets and Bead Necks. 10 Maiden Lane, N. Y. Factory at Newark, N. J.

Edge, Wm. C. & Sons—Manufacturers of Gold Jewelry, &c. Office and Factory at 46 Green St., Newark, N. J.

Ehlers & Weber—Manufacturers of Fine Jewelry. Roman Goods, Rings, Diamonds. 44½ Maiden Lane, New York.

Ehrlich & Heinz—Makers of Fine Jewelry. Lace Pins, Ear Rings, Mountings and Novelties for Jobbers. Importers and Manufacturers only. 231 Mulberry St., Newark N. J.

Griffith Brothers—15 John Street, New York. Manufacturing Jewelers. Repairing and ordered work a specialty.

Haskell, Henry C.—Rings and Badges a specialty. Corbin Building, N. Y.

Krementz & Co.—Manufacturing Jewelers, No. 182 Broadway, N. Y. Factory, Newark, N. J.

Lawson & VanWinkle—Enameled flower work a specialty, also Black Onyx, Coral, etc. 11 Maiden Lane, N. Y.

Lewis, Wessel & Leward—Manufacturers of Fine Jewelry. 41 & 43 Maiden Lane, New York.

Miller Bros. & Co.—Manuf'rs of Fine Jewelry, Diamond Goods, Sets, Lace Pins, Ear Rings, Scarf Pins, Sleeve Buttons, Studs, etc. 37 Union Square, N. Y.

Moore & Horton—No. 11 Maiden Lane, N. Y. Manufacturing Jewelers; Rings, Studs, Collars and Sleeve Buttons, Pins, Ear-rings, &c.

Noterman, Jos. & Co.—203-205 Race Street, Cincinnati, Ohio. Manufacturers of Jewelry; makers of the Olympus Diamond Goods.

Obermayer & Layng—14 and 16 Maiden Lane, New York. Manufacturing Jewelers. Diamond Mounting and Setting a specialty. Jobbing for the Trade.

Owen, G. & S. & Co.—Manufacturing Jewelers, Office, No. 3 Maiden Lane, N. Y.

Riley, J. A.—Manufacturer of Fine Jewelry, Hairpins, Side Combs, Miniature Brooches, Bead Necklaces and Scarf Holders; also Roman Bracelets, Brooches and Scarf Pins. In 14 k. Gold and Sterling Silver. 860 Broadway, New York.

Street, Geo. O. & Sons—Established 1837. Makers of Fine Jewelry; strictly first-class goods of our own make. 15 John Street, N. Y.

Ward, Thos. M.—Manufacturer of Fine Jewelry. Diamond Mountings a specialty. No. 25 John Street, N. Y.

Wheeler, Hayden W. & Co.—2 Maiden Lane, N. Y.

Jewelers' and Watchmakers' Signs and Emblems.

Stewart, Wm. B.—Successor to Albert Lussen, Manufacturer of Signs of every description. Watch, Spectacle and Pen Signs a specialty. Emblem Signs, Clock Dials, Etc. of every description done over. 587 Carroll St., Brooklyn.

Washburne, E. G. & Co.—46 Cortlandt street. The oldest firm engaged in the manufacture of Signs in the United States. Clock Dials, Watch Signs, Spectacle and Eye-Glass Signs and Signs to fit any business always in stock.

Jewelers' Tools, Machinery, etc.

American Watch Tool Co.—Waltham, Mass. Manufacturers of the Whitcomb and Webster-Whitcomb Lathes and Attachments.

Fisher & Sons—Importers and Dealers in Watchmakers' and Jewelers' Tools and Materials. Everything required by the trade. 1 Maiden Lane, N. Y.

Frasse & Co.—Importers of and Dealers in Machinery, Fine Tools and Supplies for Machinists, Silversmiths, Jewelers, Model Makers, Engravers, Die Sinkers, Sewing Machine and Other Manufacturers. 92 Park Row, New York. (P. O. Box 879.)

Friedlander, R. & L.—Importers of Watchmakers' Tools and Materials. 65 & 67 Nassau Street. Branch Office, 264 Bowery, N. Y.

Houghton & Co.—Manufacturers of Face Plates and Slide Rests. Prices reasonable and quality guaranteed. 250 Concord St., Manchester, N. H.

Kurtz, F. P.—Manufacturer of Jewelers' Machinery, Tools, Rolling Mills, Presses, Polishing Lathes, &c. 97 Cliff St., N. Y.

Langschmidt, C. F.—Dealer in Watchmakers' and Jewelers' Materials, Files, Tools, Silk Guards, Watch Glasses, etc. N. B.—All kinds of Job Work for the Trade Promptly Attended to. 907 Broadway, Room 9, between 20th and 21st Sts., N. Y.

Montgomery & Co.—105 Fulton Street, N. Y. Importers of Stubs' Files, Tools and Steel, and Manufacturing Jewelers' Supplies of all kinds.

Stark, John—Waltham, Mass. Manufacturer of the well-known Stark Lathes, Foot Wheels and Attachments.

Waltham Watch Tool Co.—Waltham, Mass. Makers of the Hopkins Lathe and Attachments.

Zimmern, Henry, & Co.—Importer of Watch Materials, Tools, Glasses and Optical Goods. 37 Maiden Lane, N. Y.

Lamp Shades, Etc.

Lewis & Co.—Manufacturers of Lamp and Candle Shades, Paper Flowers, Imported Tissues and Novelties. 2 East 14th St., New York.

Masonic Jewels.

Bedichimer, I.—Maker of a general line of Masonic Jewels, especially Mystic Shrine Badges. 618 Chestnut Street, Philadelphia.

Hunt & Fuller—Makers of the Mystic Shrine Jewels with moonstones, Cape ruby and tigerite heads. 73 Nassau Street, N. Y.

Richardson, J. W. & Co.—Manufacturers of Emblems of All Kinds. 196 Broadway, New York. Catalogues Free to the Trade on Application.

Musical Boxes.

Cuendet, E. L.—Importer of Musical Boxes and Material, 57 Maiden Lane, N. Y. Sole Agent for J. Cuendet, Auberson, Switzerland. Repairing a specialty.

Gautschi, Henry & Sons—Manufacturers and Importers of Musical Boxes. Warerooms, 1030 Chestnut Street, Philadelphia. Manufactory at Ste. Croix, Switzerland. Old and Damaged Musical Boxes carefully repaired. Material.

Jacot & Son—No. 298 Broadway, N. Y. Importers and Manufacturers of Musical Boxes.

Oils.

Nye, William F.—Manufacturer of the finest-known watch, clock and chronometer oils. Factory, New Bedford, Mass. Sold by all material dealers in the United States and Canada. European agencies: R. Haswell & Sons, 49 Spencer street, London; Versepy & Andre, 56 Rue de Paradis, Paris; Krauss & Kreutter, Chaux de Fonds, Switzerland; Koch & Co., Elberfeld, Germany.

Kelley, Ezra—Manufacturer of Fine Watch, Chronometer and Clock Oils. New Bedford, Mass. Henry Ginnel & Co., 31 Maiden Lane, N. Y., Agents for the United States and Canada, and Grimshaw & Baxter, 35 Goswell Road, London, European Agents.

Optical Goods.

Berger, Albert & Co.—Importers of Watch Glasses, Spectacles, Opera Glasses, &c., and Sole Manufacturers of the celebrated "W. B. & C." Watch Glasses and Spectacle Lenses. 47 Maiden Lane, N. Y.

Friedlander, R. & L.—65 and 67 Nassau Street, N. Y., Dealers in Optical Goods.

Geneva Optical Co.—Manufacturers of Gold, Silver, Steel and Nickel Spectacles and Eye-Glasses, Trial Frames, Trial Lenses, Prisoptometers, and other Optical Goods, Geneva, N. Y. Main Office, 23 Washington St., Chicago, Ill.

Julius King Optical Co.—Cleveland, Ohio. New York Department, 4 Maiden Lane. Manufacturers of Spectacles and Eye-glasses of all descriptions, Opera Glasses, Test Lenses, Judge Mack's Opera Glass Holders, etc.

Laurengot, J. B.—Importer of Optical Goods of all descriptions, and manufacturer of Spectacles and Eye-Glasses in Gold, Silver, &c. 33 Maiden Lane, N. Y.

Merritt, S. F.—Springfield, Mass. Manufacturer of Patented Eye-Glass Holder, Eye-Glass Hooks and Chains, etc.

Scheidig & Co., John—Importers of Optical Goods, 43 Maiden Lane, New York.

Spencer Optical Manufacturing Co.—Gold, Silver, Aluminum, Steel, Nickel and Plated Spectacles; Gold, Celluloid, Steel, Nickel and Rubber Eye-Glasses and Opera Glasses. 15 Maiden Lane, N. Y.

Want, Edwin—Successor to W. J. Suttie, Manufacturer of and Jobber in Eye-Glasses and Spectacles in Gold, Silver, Steel and Shell. No. 12 John Street, New York. Repairing a Specialty.

Zineman, M. & Bro.—Manufacturing Opticians; Makers of the "Diamanta" Spectacles and Eye-Glasses. 130 South 9th Street, Philadelphia.

Plated Chains.

Barrows, H. F. & Co.—No. Attleboro, Mass. Manufacturers Rolled Plated Chains. New York office, 1½ Maiden Lane.

Blackinton, W. & S.—No. Attleboro, Mass. N. Y. Office, 16 Maiden Lane.

Grant, J. W. & Co.—23 Calender street, Providence, R. I., Manufacturers of Rolled Plate Chains.

Hamilton & Hamilton, Jr.—7 Eddy street, Providence, R. I. 192 Broadway, N. Y., manufacturers of Rolled Plate Chains.

Kent & Stanley—Manufacturers Plated Chains. Enterprise Building, Cor. Eddy & Fountain Sts., Providence.

Platinum.

Raynor, H. M.—25 Bond Street, N. Y. Established 1859. Wholesale and Retail.

Plated Jewelry.

Foster & Bailey—Manufacturers of Jewelry, and the "Mount Hope" and "Omega" Sleeve Buttons. 60 Richmond St., Providence. New York Office, 178 Broadway.

Franklin, E. I. & Co.—No. Attleboro, Mass. Makers of Jewelry. New York Office, No. 176 Broadway.

Plainville Stock Co.—Plainville, Conn. New York Office, 176 Broadway.

Richards, E. I. & Co.—No. Attleboro, Mass. Manufacturers of Fine Rolled Plated Jewelry. New York office, 200 Broadway.

Wade, Davis & Co.—Plainville, Mass. Manufacturers of Jewelry. New York Office, 196 Broadway.

Photo-Engravers.

Bartholomew & Peckham—18 Spruce St., N. Y.

Safes.

Butler, W. H.—Fire and Burglar Proof Safes, 79 Duane St., near Broadway, N. Y.

Silverware and Silver Novelties.

Alvin Mfg. Co.—24 Boudinot St., Newark, N. J., Makers of Novelties in Sterling Silver by the Electro-Deposit Process. 10 East 14th St., N. Y.

Gorham Manufacturing Co.—Broadway and 19th Street, N. Y.

Cattelle & Decker—20 Maiden Lane, N. Y. Manufacturers of Silver Novelties and Diamond Jewelry.

Cuppia, L. A.—Manufacturer of Solid Silver Novelties, and Importer of Silver Filigree. 42 East 14th Street.

Shiebler, Geo. W.—Manufacturer of Sterling Silverware. No. 8 Liberty Place, near Maiden Lane, N. Y.

Sterling Co., The—Silversmiths; Makers of Novelties in Sterling Silver. 7 Eddy Street, Providence, R. I. N. Y. Office, 176 Broadway.

Towle Mfg. Co.—Manufacturers of Sterling Silverware. Factory, Newburyport, Mass. 149 & 151 State Street, Chicago.

Wallace, R. & Sons Mfg. Co.—Wallingford, Conn. Manufacturers of Solid Silver Ware. New York Office, 21 Park Place.

Wood & Hughes.—Manufacturers of Fine Silverware. 16 John Street, N. Y.

Whiting, Frank M., & Co.—North Attleboro, Mass. New York Office, 857 Broadway.

Silver Plated Ware.

Hartford Silver Plate Co.—Hartford, Conn.

Meriden Britannia Co.—Manufacturers of Electro-Plated Flat and Hollow Ware, Meriden, Conn., and 46 East 14th St., N. Y.

Middletown Plate Co.—Manufacturers of Superior Electro-Plate. Factories, Middletown, Conn. salesroom 22 John Street, N. Y.

Pairpoint Manufacturing Co.—New Bedford, Mass. 20 Maiden Lane, New York.

Rogers & Brother—Manufacturers of Electro-Plated Flat and Hollow Ware. 16 Cortlandt St. N. Y.

Rogers, Smith & Co.—No. 46 East 14th Street, N. Y., and Meriden, Conn.

Schade, Henry—Manufacturer of Electro Plated Ware. 56 & 58 Ainslie Street, Brooklyn, E. D. Catalogue and Price List furnished to the trade.

Simpson, Hall, Miller & Co.—Manufacturers of Fine Electro Silver Plated Ware, and Wm. Rogers' Flat Ware. No. 36 East 14th St., N. Y., and Wallingford, Conn.

Wm. Rogers Mfg Co.—Manufacturers of Silver Plated Table Ware. P. O. Drawer 30, Hartford, Conn.

Spectacle Case Manufacturers.

Bertine, P. D.—Manufacturer of Spectacle and Eye-Glass Cases. 139 William Street, near Fulton St., New York.

Koenen, A. & Bro.—Manufacturers of Leather Spectacle and Eye-Glass Cases for the Jobbing Trade only. 81 Nassau St., N. Y.

Spencer Optical Manufacturing Co.—Manufacturers of Spectacle and Eye-Glass Cases. 15 Maiden Lane, N. Y.

Show Cases, Etc.

Smith, B. & W. B.—Manufacturers of Patent Improved Dust Proof Show Cases, with Perpendicular Sliding Doors, No. 220 W. 29th St., N. Y.

Sleeve and Collar Buttons.

Howard & Son.—American Lever Sleeve Button. 7 Eddy St., Providence. N. Y. Office, No. 176 Broadway.

Marcy, Fred. I. & Co.—Acme Lever Sleeve Buttons. 95 Pine St., Providence, R. I., 198 Broadway, New York.

Thimble Manufacturers.

Ketcham & McDougall.—Improved Gold and Silver Thimbles, 198 Broadway, N. Y.

Woglom Gilbert T.—Sole Agents for the "Prime" Thimbles in Gold and Silver, manufactured by Ezra C. Prime. 34 John Street, N. Y.

Trunks, Etc.

Crouch & Fitzgerald—Manufacturers of Strongest, Lightest and Best Sample Trunks and Cases. 14 Cortlandt Street, 556 Broadway and 732 6th Avenue, N. Y. See Back Cover.

Cummings, Josiah & Son—109 Summer Street, Boston, Mass. Manufacturers of Steel Bound Sample Trunks, Sample Cases, Trays, etc., for the Jewelry Trade.

Watch Companies.

American Waltham Watch Co.—Waltham, Mass. Robbins & Appleton, No. 5 Bond St., N. Y.; 102 State St., Chicago.

Atkinson Bros.—General Agents of the Keystone Standard Watch Co. 931 Chestnut St., Phila.

Aurora Watch Co.—Aurora, Ills.

Columbus Watch Co.—Columbus, O. Office, 41 Maiden Lane, N. Y.

Elgin National Watch Co.—Offices, 76 Monroe Street, Chicago, Ills., and 192 Broadway, N. Y. Factory, Elgin, Ills.

Hampden Watch Co.—Canton, O. N. Y. Office, 178 Broadway.

Manhattan Watch Co.—234 Broadway, N. Y.

New York Standard Watch Company,—13 John St., N. Y.

Non-Magnetic Watch Co. of America.—177 Broadway, N. Y.

The Illinois Watch Co.—Springfield, Ills. New York Office, 192 Broadway. Chicago Office, 104 State Street.

The Cheshire Watch Co., Cheshire, Conn. New York Office, 198 Broadway. L. W. Sweet, Gen'l Selling Agent.

Trenton Watch Co.—Trenton, N. J. New York Office, 177 Broadway.

The E. Howard Watch and Clock Co.—41 and 43 Maiden Lane, N. Y.

United States Watch Co., Waltham, Mass.

Waterbury Watch Co.—Manufacturers of the Waterbury Watch. Factory, Waterbury. Office, 92 & 94 Liberty St., N. Y.

Watchman's Clocks.

Imhauser, E.—206 and 208 Broadway, New York. Watchman's Improved Time Detector, with Safety Lock Attachment. Send for circular.

The Standard Watchman's Clock—The Best in the Market. Send for Circular. Watchman's Time Detectors. O. E. Hausburg, 41 Maiden Lane, N. Y.

Watch Importers, Etc.

Abry, Chas. Leo—Importer and Manufacturer of Swiss Watches of all grades. 41 & 43 Maiden Lane, New York.

Beguelin Tell A.—71 Nassau St., N. Y., up stairs, Importer of Watches, Tools and Materials.

Cross & Beguelin.—Importers of Watches, Watch Tools and Materials; dealers in American Watches. No. 21 Maiden Lane, N. Y.

Didisheim, Hipp—Importer of Swiss Watches. 83 Nassau St., N. Y. Agent for the Usine Genevoise de Degrossissage d'Or, Geneva, Switzerland.

Droz, Henry E.—Importer of Watches, and Watch Case Manufacturer. Agent for the "E. Perre-gaux" Watch, and jobber in American Watches. No. 92 Fulton Street, N. Y.

Gallet, Julien & Co.—Importers of Watches. No. 1 Maiden Lane, N. Y.

Gardner, A. S., & Co.—Sole Agents for the celebrated Borel & Courvoisier Watches. No. 17 Maiden Lane, N. Y.

Haldimann, E. A.—Jobber in American Watches, 3 Maiden Lane, New York.

Hammel, L. & Co.—Importers and Dealers in Watches, Watch Materials and Watchmakers and Jewelers Tools, 35 Maiden Lane, N. Y.

Hyde's Sons, John E.—Wholesale Commission Agents for Jules Jurgensen, of Copenhagen; also of a special new movement, and for other makers of all qualities Watches. 22 Maiden Lane, N. Y.

Keller, L. H. & Co.—Successors to G. A. Huguenin, Importers of Fine Watch and French Clock Materials, No. 64 Nassau Street, N. Y.

Mathey Bros., Mathez & Co.—16 Maiden Lane, New York. Importers of all grades of plain and complicated watches and movements. Sole agents for the well-known H. L. Matile, J. J. Badollet & Co., C. H. Meylan & Co. Watches demagnetized. Factories: Brassus, Switzerland.

Robert, J. Eugene & Co.—No. 30 Maiden Lane, New York. Agent for Louis Audemar, Jules Mo-nard, Agassiz and Longines celebrated Watches.

Schwob, Adolphe—Manufacturer and Importer of Watches. 4 Maiden Lane, N. Y.

Scott, J. T. & Co.—Importers of Watches, and Manufacturers of Jewelry, and Jobbers of all Grades of American Watches, 4 Maiden Lane, N. Y.

Watch Cases.

Atlantic Watch Case Co.—Manufacturers of 14-k Gold Filled Cases. Corbin Building, N. Y.

Brooklyn Watch Case Co.—Manufacturers of all styles of Solid Watch Cases. N. Y. Office, Corbin Building.

Crescent Watch Case Co.—5 Bond St., N. Y.

Du Bois Watch Case Co.—Manufacturers of Fine Gold Watch Cases. Specialty: Raised Gold Ornamentation. 22 to 26 Morton Street, Brooklyn, N. Y. New York Office, 2 John Street. L. Combremont, Agent.

Dueber Watch Case Mfg. Co.—Manufacturers of the Famous "Dueber" Watch Cases, in Gold, Gold-Filled, Silver and Silverine. N. Y. Office, 178 Broadway.

Fidelity Watch Case Co.—Manufacturers of 14-k and 18-k Solid Gold Cases. Factory, 380 and 382 Water St., N. Y. Office, 192 Broadway.

Glatz, Charles.—Manufacturer of Gold Watch Cases, 192 Broadway, N. Y.; 149 State Street, Chicago.

Jeannot & Shiebler.—Manufacturers of Gold Watch Cases, 20 Maiden Lane, N. Y.

Pinnell, May & Co.—52 Lawrence Street, Newark, N. J. and 1½ Maiden Lane, N. Y., manufacturers of 8 k. and fine 14 k. and 18 k. Watch-cases.

Smith & Knapp—Manufacturers of Gold Watch Cases. 182 Broadway, N. Y.

Solidarity Watch Case Co. (Co-operative).—Makers of artistic engraved and ornamented cases. Patentees of fancy designs. Factory, Brooklyn, E. D. New York office, 194 Broadway. Simon Goldsmith, agent.

Watch and Chronometer Jewelers and Repairers.

Cerf, B.—Practical Watchmaker and Repairer. Repairing, adjusting, pivoting, jewelry etc., done for the trade at most reasonable rates. Escape and stem-winding wheels cut to order. 42 John Street, N. Y.

Crossman, Chas. S. & Co.—Practical Watchmakers and Repairers, also Watch jewelry for the trade. Correspondence solicited and estimates furnished. 23 Maiden Lane, N. Y.

Dreier, F., 16 Maiden Lane, New York. Send your watch repairing for Staffs, Pinions, Wheels, Dials, Springs, &c., Stem winding Wheels cut to order. Repairing for the Trade at lowest prices. French Clocks cleaned and repaired.

Oehl, Henry.—Watchmaker. Fine Watches and Chronometers repaired for the trade. Watches Demagnetized. 17 Maiden Lane, New York.

Peterman, J.—20 John Street, New York, Watch Repairer to the Trade. Speedy, Accurate and at Fair Prices.

Queen, James.—Watch and Chronometer Jeweler and Pallet Maker, 78 Nassau Street, room 8. Pi-vots inserted in Pinions, Balance, Staffs, etc.

Sirois, A.—Watch and Chronometer Repairer. 66 Nassau St., N. Y. Key Winders Altered. Fine and Complicated Watches a Specialty. Orders from the trade promptly attended to.

Watch Case Repairers.

Feinier, Joseph A.—Watch Case Maker and General Repairer. Specialty in fine Gold and Silver Cases. Jobbing promptly attended to. No. 4 Maiden Lane, N. Y.

Goll, Henry, & Co., 4 and 6 Liberty Place, N. Y. City, make a specialty of repairing Watch Cases, no matter how badly damaged. Promptness and first-class work at very low prices.

Wadsworth, G. F.—182 State St., Chicago. Watch Case Maker. Old English Cases Changed to American Stem winders. Repairing at reasonable figures and in best style. Can turn out work promptly and satisfactorily. Established 1871.

Watch Glasses, Shades, Etc.

Brown, Edwin H.—60 Nassau St., N. Y., Imported and Own Manufacture Watch Glasses. Special Watch Glasses of all kinds made to order. Fine fitting solicited.

Watches, Diamonds and Jewelry.

Aikin, Lambert & Co.—No. 23 Maiden Lane, N. Y. Wholesale Dealers in Watches and Jewelry.

Arnstein Bros. & Co.—Jobbers in American Watches and Movements, and Importers of Diamonds. 37 Maiden Lane.

Ayres, T. R. J., & Sons—Keokuk, Ia. Wholesale Jewelers. Watches, Jewelry, Diamonds, Silverware, Clocks, Optical Goods, Tools, Material, etc., at lowest eastern prices. Correspondence solicited.

Bynner, T. B.—Watches, Diamonds and Jewelry. Also a full line of best quality Roll-Plated Jewelry. 177 Broadway, New York.

Conover, David F. & Co.—American Watches, Wholesale Salesroom, Southeast corner 7th and Chestnut Streets, Philadelphia.

Durfey & Reynolds—Successors to Durfey & Shiebler; Watches, Diamonds, Jewelry. No. 10 John Street, (up-stairs) New York.

Ellis, P. W. & Co., No. 31 Wellington street and 40 Front street, East, Toronto, Ontario, Manufacturing Jewelers, Watchmakers, importers and Jobbers of Watchmakers, and Jewelers' Tools, Materials, General Supplies and American Jewelry. Correspondence solicited with manufacturers of Novelties or specialties in American Tools and Jewelry.

Floyd, Pratt & Rounds—Jobbers in American Movements and Cases, also Gold and Plated Jewelry. 408 Washington Street, Boston, Mass.

Goddard, John M.—Manufacturing Jeweler,—Seal Rings and Fine Locketts a specialty, No. 1 Maiden Lane, N. Y.

Greason J. R. & Co.—Successors to Arthur, Rumrill & Co., 182 Broadway, N. Y. Manufacturers of Fine Jewelry and Gold Chains, also Diamond Mountings.

Koch & Dreyfus—22 John Street, New York. Jobbers in Watches, Diamonds and Jewelry.

Lapp & Flershem—92-98 State St., Chicago, Ills. Wholesale dealer of everything needed by jewelers. Publishers of the "Busiest House in America" Catalogue.

Morch, Jacob—Importer of Diamonds, Watches and Bronzes. Watch Factory, Chaux-de-Fonds, Switzerland. Salesroom, 110 Broadway, Brooklyn, New York.

Myers, S. F. & Co.—Manufacturing and Wholesale Jewelers. Jobbers of all American Watches, Clocks, Materials, etc. Illustrated Catalogues to the trade. 48 & 50 Maiden Lane, and 33 & 35 Liberty street, N. Y.

Oppenheimer Bros. & Velth—Dealers in Watches and Diamonds, and Manufacturing Jewelers, No. 35 Maiden Lane, N. Y.

Pforzheimer, Keller & Co.—24 John Street, N. Y. Dealers in American Watches, Diamonds and Jewelry, and Manufacturers of Diamond Ornamented Watch Cases.

Roseman & Levy—Jobbers in all American Movements and Cases, Fine Gold and Plated Jewelry, Etc. 41 and 43 Maiden Lane, New York.

Smith & Knapp—Wholesale Dealers in American and Swiss Watches, Diamonds, Gold Jewelry and Gold Chains. 182 Broadway, N. Y.

Stern & Stern—Dealers in Watches, Jewelry and Diamonds. No. 13 Maiden Lane, N. Y.

Taylor, Geo. H. & Co.—Importers of and Jobbers in Watches, Clocks, Watch and Clock Materials, Tools, Spectacles, Eye-Glasses, &c. 136 Westminster St., Providence, R. I.

The Weber Company—Wholesale Watches and Jewelry, and Sales Agents for Dueber Watch Cases and Hampden Movements. 78 State St., Chicago.

Thrall, E. A.—Wholesale Dealer in Watches and Jewelry. No. 3 Maiden Lane, N. Y.

Trier Bros.—Wholesale Dealers in Watches and Jewelry; Importers of Opera, Field and Marine Glasses, Bohemian Garnets, Amber Goods, etc. 15 Maiden Lane, N. Y.

Van De Sande & Co., Chas.—198 Broadway, N. Y. Wholesale Dealers in Diamonds, Watches, and Jewelry.

Weber, H. & Co.—Wholesale Jewelers. Importers and Jobbers of Fine Watch Materials, Jewelers' Findings, Tools, etc. Optical Goods and Silk Guards. Agents for Whitcomb, Standard and Stark's Lathes. Diamond Luster. No. 424 Washington Street, Boston, Mass.

Watch and Clock Springs.

Logan, A. J.—Waltham, Mass. Watch Springs, Watchmakers' Tools, etc.

Washburn & Moen Manufacturing Co.—Makers of Fine Watch Mainsprings, Worcester, Mass. 16 Cliff Street, New York. 107 to 109 Lake Street, Chicago, Ill.

Watch Keys.

Birch, J. S. & Co.—Manufacturers of Patent Watch Keys. 182 & 184 Lewis St., N. Y.

Clark, A. N.—Manufacturer of the Celebrated Loop Latch Key. Plainville, Conn.

Kendrick & Davis—Manufacturers of Standard Dust-proof Watch Keys. Lebanon, N. H.

Watchmakers' and Jewelers' Tools, etc.

Cross & Beguelin—Importers of Watches, Watch Tools and Materials. Dealers in American Watches, 21 Maiden Lane, N. Y.

Keller, L. H. & Co.—Importers of Watchmakers' and Jewelers' Tools, Materials, etc. 64 Nassau Street, N. Y.

White Stone Goods.

Smith, Warren G. & Co.—Manufacturers of White Stone Goods and Baseball Novelties. No. 170 Broadway, New York.

JOSIAH CUMMINGS & SON,

101, 105, 109, 111 & 113 Summer Street,

Boston, Mass.

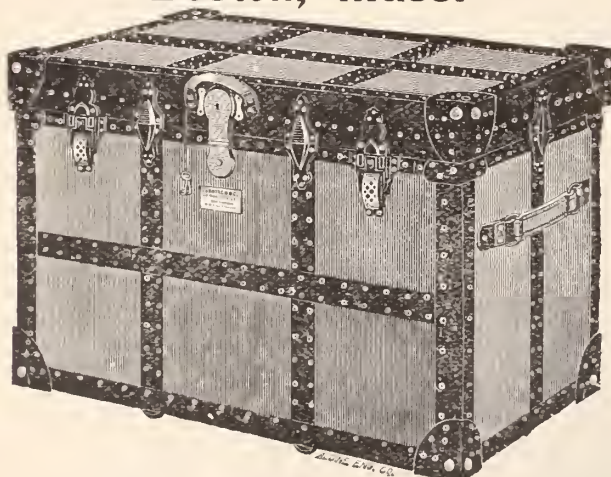

Light Pat. Steel Jewelry Trunk.

SOLE MANUFACTURERS OF
STEEL AND LINENOID

Sample Trunks and Cases.

A FULL LINE OF SAMPLE TRUNKS ALWAYS IN STOCK.

SEND FOR CATALOGUE.

VALUABLE INSTRUCTION BOOKS

FOR SALE BY

The Jewelers' Circular Pub. Co., 189 Broadway, N. Y.

- GOLDSMITHS' HANDBOOK**, containing full instructions for the Alloying and Working of Gold. By GEO. E. GEE. Price, post-paid, \$1 20
- SILVERSMITHS' HANDBOOK**, containing full instructions for the Alloying and Working of Silver. By GEO. E. GEE. Price, post-paid, 1 20
- PRACTICAL INSTRUCTION IN THE ART OF LETTER ENGRAVING.** By G. F. WHELPLEY. Price, post-paid, 2 00
- KEMLO'S WATCH REPAIRER'S HANDBOOK.** Illustrated. For beginners and advanced workmen. By F. KEMLO. Price, post-paid, 1 25
- WATCH AND CLOCK MAKING**, (with 69 diagrams). By DAVID GLASGOW, President of the British Horological Institute. Price, post-paid, 2 00
- TREATISE ON WATCHWORK, Past and Present.** By the Rev. H. L. NELTHROPP, M. A., F. S. A. *Numerous Illustrations.* Crown, 8vo, cloth. Price, post-paid, 2 50
- TREATISE ON MODERN HOROLOGY in Theory and Practice.** By M. CLAUDIUS SAUNIER. Translated by JULIEN TRIPPLIN, Besançon Watch Manufacturer, and EDWARD RIGG, M. A., Assayer in the Royal Mint London. Price, 15 00
- This valuable work comprises 832 large octavo pages, with 78 Wood Cuts and 21 colored double-page, copper-plate Engravings, is printed on excellent paper and bound in half calf, with a handsome and appropriate ornament in gold on front cover.*
- WATCH AND CLOCKMAKER'S HANDBOOK, DICTIONARY AND GUIDE.** 1889 Edition. Revised. By F. J. BRITTEN. Price, post-paid, 2 00
- WATCHMAKER'S HANDBOOK.** Latest edition, revised and enlarged. Same Author and Translator, and intended as a Companion to the Treatise. Illustrated by 14 double-page Copper-plate Engravings and numerous Wood Cuts: cloth cover. Price, post-paid, 3 50
- HANDBOOK FOR OPTICIANS.** By W. BOHNE. Illustrated. Price 2 50
- DETECTION AND CORRECTION OF VISUAL IMPERFECTIONS.** (With Test Type.) By DR. C. A. BUCKLIN, A. M., M.D. Price, post-paid, 1 00
- THE WATCH JOBBER'S HANDY BOOK.** A Practical Manual on Cleaning, Repairing and Adjusting Watches; with Information on the Tools, Materials, Appliances and Processes employed in Watchwork. By PAUL N. HASLUCK. 100 Illustrations, 0 80
- THE CLOCK JOBBER'S HANDY BOOK.** A Practical Manual on Cleaning, Repairing and Adjusting Clocks; with Information on the Tools, Materials, Appliances and Processes used in Clockwork. By PAUL N. HASLUCK. 100 Illustrations, 0 80
- PRIZE ESSAY ON THE BALANCE SPRING AND ITS TECHNICAL ADJUSTMENTS** (Baroness Burdett Coutts' Prize). By W. IMMISCH. Cuts, crown 8vo, cloth, 1 00

SEPTEMBER.

American Art..... 29
 Around Boston..... 82
 Attleboros, The..... 85
 Chicago Briefs..... 42
 Chicago Horological Institute..... 89
 Cincinnati Letter..... 85
 Combination of Independent Full Second and Chronograph with Zero Setting.... 69
 Communications..... 66
 Complete History of Watch and Clock Making in America—Watch Case Making Cylinder Plugging Tool..... 81
 Fashions in Jewelry..... 57
 " Art Glass and Ceramics..... 61
 Foreign Gossip..... 73
 Foreign Matters..... 41
 Glimpses of the Paris Exposition..... 30
 Gorham Mfg. Co..... 34
 Meriden Britannia Co..... 30
 Standard Time Service and Seth Thomas Clocks..... 30
 Waterbury Pyramid..... 31
 Kent & Stanley..... 37
 Imperial Diamond, The..... 37
 Gossip of the Month..... 25
 In the South..... 46
 Jewelers' Security Alliance..... 38
 Jewelers' and Tradesmen's Company, The..... 93
 Lathes and Lathe Work..... 62
 Mechanical Ocular Defects..... 65
 Motive Force in Watches, The..... 78
 Neglected Problems—Measuring the Wheel and Pinion Depths..... 93
 New Watch and Clock Key..... 54
 Paris Gossip..... 49
 A Rare Collection of Jeweled Bonnets..... 49
 Obituary—John J. Hyde..... 106
 Plate with Aluminum, To..... 74
 Providence Notes..... 86
 Quaker City, The..... 46
 Recent Patents..... 53
 Trade Gossip..... 97
 Among the Watch and Clock Companies, 105
 Workshop Notes..... 77

OCTOBER.

Around Boston..... 53
 Attleboros, The..... 101
 Chain, The..... 78
 Chicago Briefs..... 42
 Communications..... 93
 Complete History of Watch and Clock Making in America—Watch Case Making..... 86
 Does it Pay to be Honest?..... 31
 Fashions in Jewelry..... 58
 " Art Glass and Ceramics..... 61
 Foreign Gossip..... 73
 Foreign Matters..... 97

OCTOBER—Continued

Gossip of the Month..... 27
 Glimpses of the Paris Exposition..... 32
 M. Falize on the American Exhibit... 32
 Standard Time Service and Seth Thomas Clocks..... 32
 Exhibits of Geo. Agassiz and E. Francillon..... 36
 The Gorham Co.'s Exhibit..... 37
 Exhibit of American Precious Stones, J. F. Fradley & Co.'s Exhibit..... 42
 History of the Bracelet, The..... 69
 Improved Arbor for Clocks..... 66
 Improvement in Complicated Watches.... 82
 In the South..... 102
 Jewelers' League, The..... 82
 Jewelers' Security Alliance..... 54
 Jewelers' and Tradesmen's Company, The..... 54
 Mechanical Ocular Defects..... 65
 Mutual Relations of Refraction, Accommodation and Convergence..... 65
 Northwest, The..... 50
 Obituary Nathaniel Grant—Wm. F. Ladd, Fred'k W. Gesswein—Elijah Peacock—Sigmund Hyman—Alzomora Buck..... 98
 Our Round Table..... 89
 Paris Gossip..... 57
 Problems in the Detached Lever Escapement..... 81
 Proceedings of the Watchmakers' and Jewelers' Union..... 89
 Providence Notes..... 49
 Quaker City, The..... 46
 Recent Patents..... 85
 Repeating Arrangement for Watches and Clocks..... 74
 " Safest " Watch, The..... 81
 Trade Gossip..... 105
 Among the Watch and Clock Companies, 113
 To Revamp Nickel Movements..... 46
 Two Recent Optical Inventions..... 66
 Universal Watch..... 77
 Workshop Notes..... 70

NOVEMBER.

Advice to Watchmakers' Apprentices... 74
 Around Boston..... 53
 Attleboros, The..... 105
 Chicago Briefs..... 66
 Communications..... 106
 Complete History of Watch and Clock Making in America—Chronometer Makers 101
 Dr. Wells' Patent Eye Glass..... 81
 Factory Clock showing Day's Production.. 77
 Fashions in Jewelry..... 57
 " Art Glass and Ceramics..... 61
 Foreign Gossip..... 73
 Foreign Matters..... 65
 Gossip of the Month..... 33
 How to Drill a Staff..... 90

NOVEMBER—Continued

How to Make a Swiss Barrel Bridge..... 93
 Jewelers' League, The..... 78
 Jewelers' Security Alliance..... 62
 Jewelers' and Tradesmen's Company, The..... 105
 Last Glimpses of the Paris Exposition.... 38
 Paris Awards..... 46
 Mechanical Ocular Defects..... 89
 Manufacturers in Japanese Prisons..... 90
 Mystic Jewels..... 50
 New Safety Watch Bow..... 81
 New Free Escapement..... 78
 New Compensated Clock Pendulum..... 77
 New York Jewelers' Association..... 104
 New York Jewelers' Board of Trade..... 98
 Northwest, The..... 70
 Obituary—William M. Weil..... 106
 Our Round Table..... 82
 Paris Gossip..... 49
 Proceedings of the Watchmakers' and Jewelers' Union..... 82
 Providence Notes..... 50
 Quaker City, The..... 105
 Recent Patents..... 97
 Stark's Mainspring Winder..... 98
 Suitable Engine for Jewelers..... 98
 To Pivot a Staff, etc..... 93
 Trade Gossip..... 113
 Among the Watch and Clock Companies, 121
 Workshop Notes..... 94

DECEMBER.

Apparatus for Mounting the Breguet Spiral Springs..... 85
 Around Boston..... 97
 Chicago Briefs..... 30
 Communications..... 93
 Complete History of Watch and Clock Making in America—Chronometer Makers 86
 Crystal Anniversary of the N. Y. Jewelers' Association..... 31
 Convention of the Ohio Watchmakers and Jewelers' Association..... 73
 Fashions in Jewelry..... 58
 " Art Glass and Ceramics..... 62
 Foreign Matters..... 57
 Gossip of the Month..... 25
 Gold Alloys..... 85
 Gorham Mfg. Co.'s Subscription Book.... 40
 Honor to the Trade..... 29
 Horological School Notes..... 46
 Holiday Window Attractions..... 43
 Jewelers' League, The..... 69
 Jewelers' Security Alliance..... 69
 Jewelers' and Tradesmen's Company, The..... 40
 Lathes and Lathe Work..... 81
 Mechanical Ocular Defects..... 69

DECEMBER—Continued

Mining and Mineral Industry of the United States..... 54
 Model Watch Key Factory..... 86
 New York Jewelers' Association..... 47
 New York Jewelers' Board of Trade..... 29
 Our Round Table..... 74
 Paris Gossip..... 65
 Proceedings of the Watchmakers' and Jewelers' Union..... 74
 Providence Notes..... 94
 Quaker City, The..... 100
 Recent Patents..... 49
 Retrospect of the Paris Exposition..... 90
 Trade Gossip..... 103
 Among the Watch and Clock Companies, 106
 Universal Handle, A..... 85
 Workshop Notes..... 82

JANUARY,

Around Boston..... 31
 Barometer Compensation on the Pendulum, 71
 Breguets' Escapement with Natural Impulses..... 68
 Carving in Ivory..... 51
 Chicago Briefs..... 30
 Communications..... 37
 " Double Event " Cup..... 26
 Fashions in Jewelry..... 52
 " Art Glass and Ceramics..... 56
 Foreign Matters..... 82
 Foreign Gossip..... 47
 Gossip of the Month..... 21
 Jerusalem to be the Initial Meridian..... 68
 Jewelers' League, The..... 76
 Jewelers' Security Alliance..... 76-37
 Jewelers' and Tradesmen's Company, The . 34
 Mechanical Ocular Defects..... 59
 Neglected Problems..... 38
 New York Jewelers' Association..... 47
 New York Jewelers' Board of Trade..... 47
 Northwest, The..... 34
 Obituary..... 29
 Our Round Table..... 41
 Paris Gossip..... 48
 Parisian Novelty..... 36
 Pliers for Straightening Bent Pivots..... 67
 Problems in the Detached Lever Escapement 63
 Proceedings of the Watchmakers' and Jewelers' Union..... 41
 Providence Notes..... 33
 Recent Patents..... 75
 Screw Gauge..... 67
 Trade Gossip..... 85
 Workshop Notes..... 64
 World of Invention, The Improved Stem Winding and Stem Setting Watches by Isaac Goddard Improved Watch Bow, New Pendulum adjusted to Temperature. New Tools for Watchmakers. Receptacle Watch Case. The Spencer Opera Glass Holder..... 79



